

ck-12

flexbook
next generation textbooks

CK-12 Chemistry Second Edition

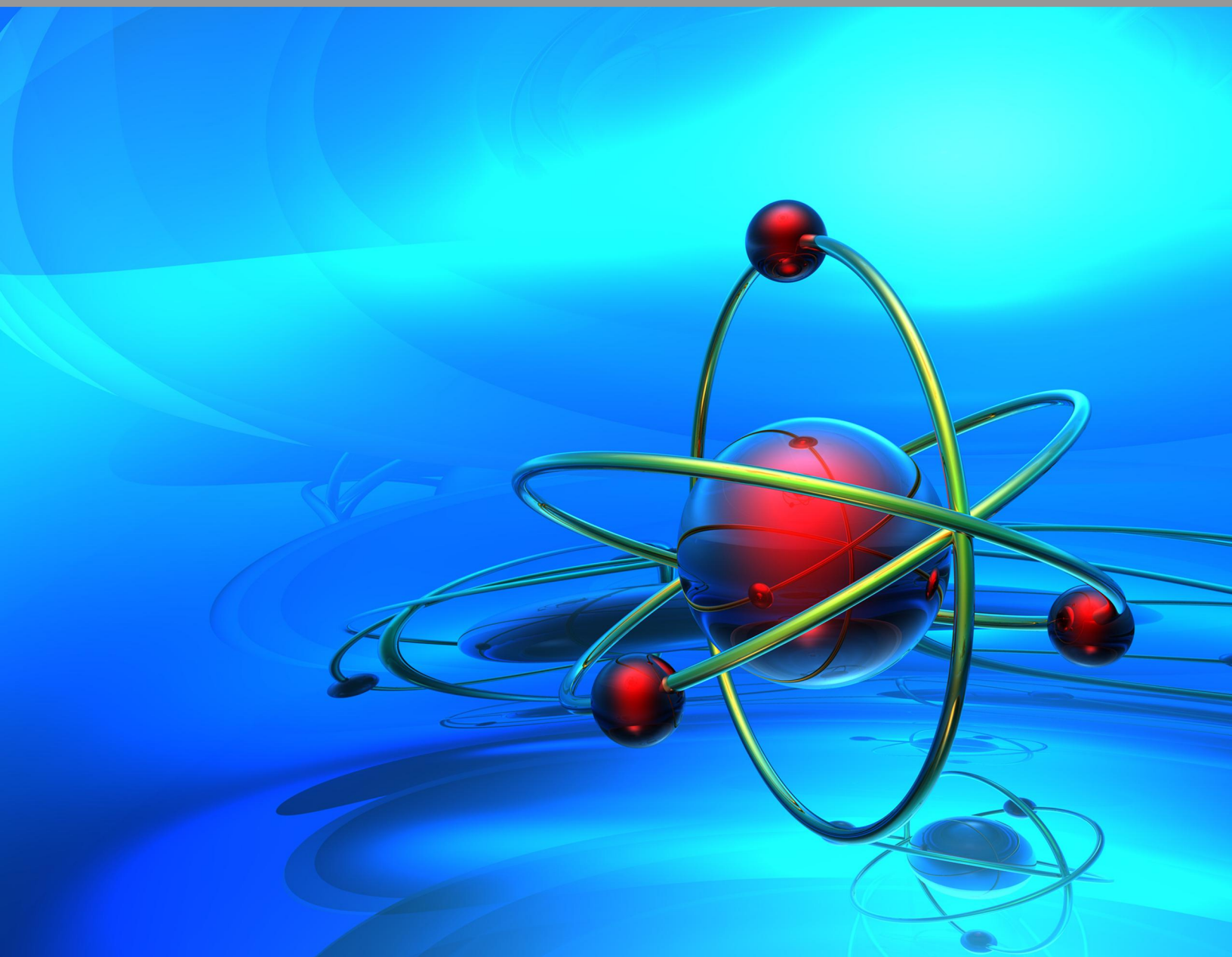

CK-12 Chemistry - Second Edition

Sharon Bewick, Ph.D. (SharonB)
Richard Parsons, (RichardP)
Therese Forsythe, (ThereseF)
Shonna Robinson, (ShonnaR)
Jean Dupon, Ph.D. (JeanD)

Say Thanks to the Authors

Click <http://www.ck12.org/saythanks>

(No sign in required)

To access a customizable version of this book, as well as other interactive content, visit www.ck12.org

CK-12 Foundation is a non-profit organization with a mission to reduce the cost of textbook materials for the K-12 market both in the U.S. and worldwide. Using an open-content, web-based collaborative model termed the **FlexBook®**, CK-12 intends to pioneer the generation and distribution of high-quality educational content that will serve both as core text as well as provide an adaptive environment for learning, powered through the **FlexBook Platform®**.

Copyright © 2013 CK-12 Foundation, www.ck12.org

The names “CK-12” and “CK12” and associated logos and the terms “**FlexBook®**” and “**FlexBook Platform®**” (collectively “CK-12 Marks”) are trademarks and service marks of CK-12 Foundation and are protected by federal, state, and international laws.

Any form of reproduction of this book in any format or medium, in whole or in sections must include the referral attribution link <http://www.ck12.org/saythanks> (placed in a visible location) in addition to the following terms.

Except as otherwise noted, all CK-12 Content (including CK-12 Curriculum Material) is made available to Users in accordance with the Creative Commons Attribution-Non-Commercial 3.0 Unported (CC BY-NC 3.0) License (<http://creativecommons.org/licenses/by-nc/3.0/>), as amended and updated by Creative Commons from time to time (the “CC License”), which is incorporated herein by this reference.

Complete terms can be found at <http://www.ck12.org/terms>.

Printed: October 9, 2013

flexbook
next generation textbooks



AUTHORS

Sharon Bewick, Ph.D. (SharonB)
Richard Parsons, (RichardP)
Therese Forsythe, (ThereseF)
Shonna Robinson, (ShonnaR)
Jean Dupon, Ph.D. (JeanD)

EDITORS

Shonna Robinson, (ShonnaR)
Richard Parsons, (RParsons)
Richard Parsons, (RichardP)

CONTRIBUTORS

Jean Dupon, Ph.D. (JeanD)
Therese Forsythe, (ThereseF)
Jonathan Edge, (JonathanE)

Contents

1	Introduction to Chemistry	1
1.1	What Is Chemistry?	2
1.2	The Process of Science	6
1.3	References	18
2	Measurement in Chemistry	19
2.1	Making Observations	20
2.2	Measurement Systems	25
2.3	The SI System of Measurement	28
2.4	Significant Figures	35
2.5	Using Algebra in Chemistry	42
2.6	Scientific Notation	46
2.7	Evaluating Measurements	50
2.8	Graphing	53
2.9	References	62
3	Matter and Energy	63
3.1	What is Matter?	64
3.2	Properties and Changes of Matter	71
3.3	Energy	75
3.4	References	82
4	The Atomic Theory	83
4.1	The Atomic Theory	84
4.2	Further Understanding of the Atom	90
4.3	Atomic Structure	99
4.4	References	110
5	The Bohr Model of the Atom	111
5.1	The Nature of Light	112
5.2	Atoms and Electromagnetic Spectra	118
5.3	The Bohr Model of the Atom	121
5.4	References	126
6	The Quantum Mechanical Model of the Atom	127
6.1	The Dual Nature of Light	128
6.2	Characteristics of Matter	133
6.3	Quantum Numbers, Orbitals, and Probability Patterns	137
7	The Electron Configuration of Atoms	144
7.1	Electron Arrangement	145
7.2	Valence Electrons	153

8	Electron Configuration and the Periodic Table	158
8.1	Mendeleev's Periodic Table	159
8.2	Families and Periods of the Periodic Table	162
9	Chemical Periodicity	172
9.1	The Periodic Table	173
9.2	Periodic Trends in Atomic Size	176
9.3	Periodic Trends in Ionic Size	185
9.4	Periodic Trends in Ionization Energy	188
9.5	Periodic Trends in Electronegativity	194
9.6	Periodic Trends in Electron Affinity	198
10	Ionic Bonds and Formulas	202
10.1	Ions and Ion Formation	203
10.2	Ionic Compounds	211
10.3	Writing Ionic Formulas	215
10.4	Naming Ionic Compounds	222
10.5	References	226
11	Covalent Bonds and Formulas	227
11.1	The Covalent Bond	228
11.2	Covalent Formulas and Nomenclature	241
11.3	Electronic and Molecular Geometry	244
11.4	The Geometrical Arrangement of Electrons and Molecular Shape	254
12	The Mole Concept	265
12.1	Determining Formula and Molar Masses	266
12.2	The Mole	269
12.3	Percent Composition	273
12.4	Empirical and Molecular Formulas	276
13	Chemical Reactions	280
13.1	Chemical Reactions and Equations	281
13.2	Balancing Chemical Equations	285
13.3	Types of Reactions	290
14	Stoichiometry	299
14.1	Introduction to Stoichiometry	300
14.2	Stoichiometric Calculations	303
14.3	Limiting Reactant	314
14.4	Percent Yield	320
15	The Behavior of Gases	325
15.1	The Three States of Matter	326
15.2	Gases	330
15.3	Gases and Pressure	333
15.4	Gas Laws	340
15.5	Universal Gas Law	350
15.6	Molar Volume	355
15.7	Stoichiometry Involving Gases	361
16	Condensed Phases: Solids and Liquids	365
16.1	Properties of Solids and Liquids	366

16.2	Intermolecular Forces of Attraction	370
16.3	Ionic, Metallic, and Network Condensed Phases	379
16.4	Vapor Pressure and Boiling	385
16.5	Heat and Changes of State	393
16.6	Phase Diagrams	401
16.7	References	407
17	Solutions and Their Behavior	408
17.1	Properties of Solutions	409
17.2	Solution Formation	414
17.3	Measuring Concentration	423
17.4	Factors Affecting Solubility	428
17.5	Solubility Graphs	433
17.6	Colligative Properties	439
17.7	Separating Mixtures	445
17.8	Reactions Between Ions in Solutions	451
17.9	References	459
18	Chemical Kinetics	460
18.1	Rate of Reactions	461
18.2	Collision Theory	466
18.3	Potential Energy Diagrams	471
18.4	Factors That Affect Reaction Rates	479
18.5	Multi-step Reaction	492
19	Chemical Equilibrium	498
19.1	Introduction to Equilibrium	499
19.2	Equilibrium Constant	503
19.3	The Effects of Applying Stress to Reactions at Equilibrium	509
19.4	Slightly Soluble Salts	525
20	Acids and Bases	530
20.1	Properties of Acids and Bases	531
20.2	Arrhenius Acids and Bases	536
20.3	The pH Concept	539
20.4	Strength of Acids and Bases	547
20.5	Brønsted-Lowry Acids and Bases	554
20.6	Lewis Acids and Bases	560
21	Neutralization	563
21.1	Neutralization	564
21.2	Titration	569
21.3	Buffers	583
21.4	References	588
22	Thermochemistry	589
22.1	Energy Change in Reactions	590
22.2	Enthalpy	595
22.3	Spontaneous Processes	603
22.4	Entropy	608
22.5	Gibbs Free Energy	614

23	Electrochemistry	619
23.1	Origin of the Term Oxidation	620
23.2	Oxidation – Reduction	623
23.3	Balancing Redox Equations Using the Oxidation Number Method	630
23.4	Electrolysis	638
23.5	Galvanic Cells	644
24	Nuclear Chemistry	653
24.1	Discovery of Radioactivity	654
24.2	Nuclear Notation	657
24.3	Nuclear Force	659
24.4	Nuclear Disintegration	663
24.5	Nuclear Equations	668
24.6	Radiation Around Us	674
24.7	Applications of Nuclear Energy	679
24.8	References	689
25	Organic Chemistry	690
25.1	Carbon, A Unique Element	691
25.2	Hydrocarbons	695
25.3	Aromatics	706
25.4	Functional Groups	714
25.5	Biochemical Molecules	729
25.6	References	740
26	Chemistry Glossary	741
26.1	A	742
26.2	B	744
26.3	C	745
26.4	D	747
26.5	E	748
26.6	F	750
26.7	G	751
26.8	H	752
26.9	I	753
26.10	J	754
26.11	K	755
26.12	L	756
26.13	M	757
26.14	N	759
26.15	O	760
26.16	P	761
26.17	Q	763
26.18	R	764
26.19	S	765
26.20	T	767
26.21	U	768
26.22	V	769
26.23	W	770
26.24	X	771
26.25	Y	772
26.26	Z	773

CHAPTER

1

Introduction to Chemistry

Chapter Outline

- 1.1 WHAT IS CHEMISTRY?
 - 1.2 THE PROCESS OF SCIENCE
 - 1.3 REFERENCES
-

1.1 What Is Chemistry?

Lesson Objectives

The student will:

- give a brief history of how chemistry began.
- list some new materials produced by chemists.

Vocabulary

- chemistry

Introduction

During medieval times, a group of people known as alchemists began looking for ways to transform common metals, such as lead, copper, and iron, into gold. Can you imagine how much money you would make if you could go to the store, buy some iron nails, and turn them into gold? You'd be rich in no time!

The Origin and Evolution of Chemistry

Alchemists experimented with many different kinds of chemicals, searching for what they termed the “philosopher’s stone” – a legendary substance necessary for transforming common metals into gold (see **Figure 1.1**). We now know that there is no such thing as a philosopher’s stone, nor is there any chemical reaction that creates gold from another metal. We know this because we now have a much better understanding of how the matter in our universe behaves. Nevertheless, those early alchemists kindled interest in chemical transformations and inspired the development of modern chemistry.

Chemistry is the scientific study of matter and the changes that it undergoes. It’s no coincidence that the word “chemistry” looks a lot like the word “alchemy.” Early alchemists were commonly known as “chemists,” and over time, people started referring to their work, particularly the more legitimate forms of it, as chemistry. While it may seem strange, in many ways it is appropriate that our word for the present-day study of matter comes from the early practice of alchemy. A lot of the techniques and equipment fundamental to modern chemistry were actually developed by early alchemists.

Alchemy was practiced in China and India and later in the Arab world and Europe. The origin of the word “alchemy,” however, is something of a mystery. Certainly, early Europeans derived the term “alchemy” from the Arabic word “al-kimia,” meaning “the art of transformation” (of course, the transformation that alchemists were primarily concerned with involved the creation of gold). Most of what we know today about early alchemy is based

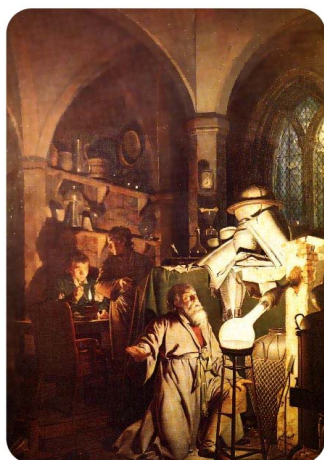
**FIGURE 1.1**

This painting shows an alchemist in search of the philosopher's stone.

on translations of Arabic documents, as the Muslim alchemists were among the first to keep careful notes about their experiments.

Even though our earliest records of alchemy come from the Arab Empire, some scholars believe that Arabs adopted alchemy and the word “al-kimia” from the Greeks around 650 AD. The Greeks, in turn, may have learned of alchemy from the Egyptians. Khem was an ancient name for Egypt, and the Egyptians of early history were known as masters at the art of working with gold. It's very likely that al-kimia is actually a distorted version of the word “al-kimiya,” meaning “the art of the land of Khem,” or the art of Egypt.

Medieval Europeans were similarly fascinated by alchemy. Unfortunately, many alchemists in Europe borrowed ideas from the more mystical of the Arabian alchemists, and, as a result, European alchemy quickly became associated with wizardry, magic, and the search for the philosopher's stone. It wasn't until the late 17th century that European chemists began applying the scientific method (see the lesson “The Process of Science” for a more detailed discussion about the scientific method). Robert Boyle (1627 – 1691) was the first European chemist to do so, using quantitative experiments to measure the relationship between the pressure and the volume of a gas. His use of scientific methods paved the way for other European chemists and helped to establish the modern science of chemistry.

The man who would greatly advance the development of modern chemistry was Antoine Lavoisier (1743 - 1794). Considered the father of modern chemistry, Lavoisier (seen in **Figure 1.2**) discovered that although matter may change its shape or form, its mass always remains the same. As a result, he would state the first version of the law of conservation of mass. Lavoisier also wrote the first extensive list of elements, including oxygen and hydrogen, and helped to reform chemical nomenclature.

What Chemists Do

You might wonder why the study of chemistry is so important if you can't use it to turn iron into gold or to develop a potion that will make you immortal. Why didn't chemistry die when scientists like Boyle and Lavoisier proved alchemy was nothing but a hoax? Although we can't use chemistry to make gold or to live forever, modern chemistry is still very powerful. There may be no such thing as a potion that cures all diseases, but many chemists today are working to develop cures for specific diseases, including HIV/AIDS and various forms of cancer.

Chemists apply information about matter and the changes it undergoes to improve our lives in many different ways. Modern chemists study not only chemicals that can help us, but also chemicals that can hurt us. For example,

Semiconductors are another class of “new” materials whose development is largely based on our improved understanding of chemistry. Because scientists know how matter is put together, they can predict how to fine-tune the chemical composition of a semiconductor in order to make it absorb light and act as a solar cell, or to emit light and act as a light source.

We’ve come a long way from our early days of producing bronze and steel. Nevertheless, as our understanding of chemistry improves, we will be able to create even more useful materials than the ones we have today.

Lesson Summary

- Chemistry began as the study of alchemy. Most alchemists were searching for the philosopher’s stone, a fabled substance that could turn common metals into gold.
- Chemistry is the scientific study of matter and the changes that it undergoes.
- The word “chemistry” comes from the Arabic word “al-kimia,” meaning “the art of transformation.”
- Chemists apply information about matter and the changes it undergoes in many different ways to improve our lives.

Further Reading / Supplemental Links

The *learner.org* website allows users to view the Annenberg series of chemistry videos. You are required to register before you can watch the videos, but there is no charge to register. The video called “The World of Chemistry” relates chemistry to other sciences and daily life.

- <http://learner.org/resources/series61.html>

Review Questions

1. What was the origin of the word “chemistry”?
2. Name at least two new materials created by chemists in the last 40 years.

1.2 The Process of Science

Lesson Objectives

The student will:

- describe the scientific method of problem solving.
- list some values of the scientific method of problem solving.
- describe the difference between hypothesis, theory, and scientific law as scientific terms.
- explain the necessity for experimental controls.
- identify components in an experiment that represent experimental controls.
- explain the concept of a model and why scientists use models.
- explain the limitations of models as scientific representations of reality.

Vocabulary

- controlled experiment
- experiment
- hypothesis
- model
- problem
- scientific law
- scientific method
- theory

Introduction

Socrates (469 BC - 399 BC), Plato (427 BC - 347 BC), and Aristotle (384 BC - 322 BC) are among the most famous of the Greek philosophers. Plato was a student of Socrates, and Aristotle was a student of Plato. These three were probably the greatest thinkers of their time. Aristotle's views on physical science were, in particular, highly influential and widely accepted until well into the 1300s.

Unfortunately, many of Aristotle's opinions were wrong. Aristotle was a brilliant man without doubt, but he was using a method unsuitable for determining the nature of the physical world. The philosopher's method depended on logical thinking and not on observing the natural world. This led to many errors in Aristotle's views on nature. Let's consider two of Aristotle's ideas as examples.

In Aristotle's opinion, men were bigger and stronger than women, so it was logical to him that men would have more teeth than women do. Thus, Aristotle concluded this as a fact without actually counting the number of teeth in any mouths. Had he done so, he would have found that men and women have exactly the same number of teeth. As another example, Aristotle considered what would happen if he were to drop two balls identical in all ways but mass. In his mind, it was clear that the heavier ball would fall faster than a lighter one would, and he concluded that

this must be a law of nature. Once again, he did not consider doing an experiment to see which ball would fall faster. This conclusion, however, was also incorrect. Eighteen centuries later, Galileo tried this experiment by dropping two balls of different masses off a building (the Leaning Tower of Pisa, according to legend). Galileo discovered, by experimental observation, that the two balls hit the ground at exactly the same time. Aristotle's logical conclusion was again wrong.

The Scientific Method of Problem Solving

In the 16th and 17th centuries, innovative thinkers were developing a new way to understand the nature of the world around them. They were developing a method that relied upon making observations of phenomena and drawing conclusions that corresponded to their observations.

The **scientific method** is a method of investigation involving experimentation and observation to acquire new knowledge, solve problems, and answer questions. Scientists frequently list the scientific method as a series of steps. Some scientists oppose this listing of steps because not all steps occur in every case, nor do they always occur in the same order. The scientific method is listed here as a series of steps, but you should remember that you are not required to rigidly follow this list. Instead, the scientific method is a valuable tool that provides a basic and adaptable strategy for tackling scientific questions.

The Steps in the Scientific Method

Step 1: Identify the **problem** or phenomenon that needs to be investigated. This is sometimes referred to as “defining the problem.”

Step 2: Gather and organize data on the problem. This step is also known as “making observations.”

Step 3: Suggest a possible solution or explanation. A suggested solution is called a **hypothesis**.

Step 4: Test the hypothesis by making new observations.

Step 5: If the new observations support the hypothesis, you accept the hypothesis for further testing. If the new observations do not agree with your hypothesis, add the new observations to your observation list and return to Step 3.

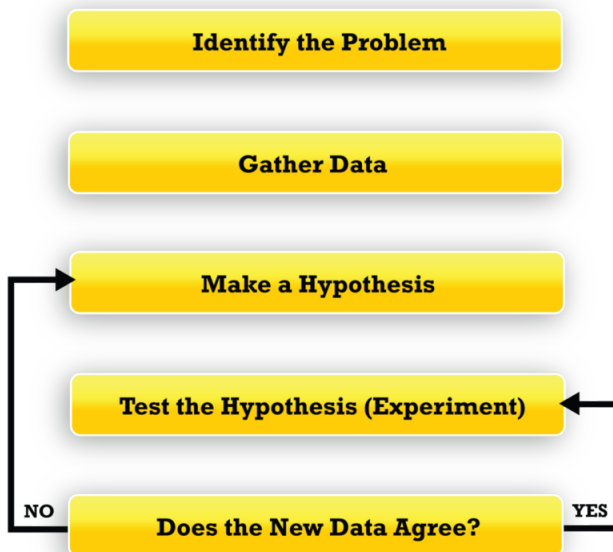

Suppose you are required to maintain a large campfire, but you are completely unfamiliar with the property that makes objects combustible (able to burn). The first step in the scientific method is to define the problem. The problem statement for this investigation is: What property makes objects combustible?

The next step is to gather data on the problem. At the beginning, you may be collecting objects at random to put into the fire. It is important to keep good records of what objects were tried and whether or not they burned. A list of organized data (observations) is shown in **Table 1.1**.

TABLE 1.1: List of Items Tried in the Fire

Will Burn	Won't Burn
tree limbs	rocks
chair legs	bricks
pencils	marbles
baseball bat	hubcaps



The list of organized observations helps because now you can focus on only collecting items on the “will burn” list and not waste any effort by dragging items that won’t burn to the fire. However, you would soon use up all the items on the “will burn” list, making it necessary to guess what property the “will burn” objects have that allow them to burn. If you had that answer, you could keep the fire going by bringing objects that may not be on the “will burn” list but have the “will burn” property.

The third step in the scientific method is to suggest a hypothesis. A hypothesis is a tentative explanation that can be tested by further investigation. Your guess about what property makes the “will burn” objects combustible is a hypothesis. Suppose you notice that all the items on the “will burn” list are cylindrical in shape, so you hypothesize that “cylindrical objects burn.”

The fourth step in the scientific method is to test your hypothesis. To test the hypothesis that cylindrical objects burn, you go out and collect a group of objects that are cylindrical, including iron pipes, soda bottles, broom handles, and tin cans. When these cylindrical objects are placed in the fire and most of them do not burn, you realize your hypothesis is not supported by these new observations. The new observations are the test, but your hypothesis has failed the test.

When the new observations fail to support your hypothesis, you reject your original hypothesis, add your new data to the table, and make a new hypothesis based on the updated observations list. A new updated table is seen in **Table 1.2**.

TABLE 1.2: List of Items Tried in the Fire

Will Burn	Won't Burn
tree limbs	rocks
chair legs	bricks
pencils	marbles

TABLE 1.2: (continued)

Will Burn	Won't Burn
baseball bat	hubcaps
broom handle	iron pipes
	soda bottles
	tin cans

According to the schematic diagram of the scientific method, if the new data does not support the hypothesis, the scientist returns to Step 3 and makes a new hypothesis. When the hypothesis is supported by the the results of several experiments, you might think that the work is finished. For a hypothesis to be useful, however, it must withstand repeated testing. Other scientists must be able to repeat the experiments using the same materials and conditions and get the same results. Scientists submit reports of research to other scientists, usually by publishing an article in a scientific journal, so that the work can be verified.

Scientific Hypotheses, Theories, and Laws

Hypotheses that have passed many supportive tests are often called theories. A **theory** is an explanation that summarizes a hypothesis or a set of hypotheses and has been supported with repeated testing. Theories have a great deal more supportive testing behind them than do hypotheses. Suppose your new hypothesis is “wooden objects burn.” You will find this hypothesis more satisfactory since all of the wooden objects you try will burn. You can see from this example that the hypothesis does not become what we think of as a “fact” but rather a tentatively accepted theory, which must undergo continuous testing and possible adjustments. Even if your theory seems successful, you might be ignoring other types of combustible materials, such as a large stack of old car tires, objects made of fabric or paper, or perhaps containers of petroleum. You can see that even though you are quite satisfied with your theory because it does the job you want it to do, you actually do not have a complete statement on all the properties that make objects burn.

In science, theories can either be descriptive (qualitative) or mathematical (quantitative). However, a scientific theory must be falsifiable, or capable of being proved false, in order to be accepted as a theory. A theory is never proven true and is never a “fact.” As long as a theory is consistent with all observations, scientists will continue to use it. When a theory is contradicted by observations, it is discarded and replaced.

A theory is also a possible explanation for a law. A **scientific law** is a statement that summarizes the results of many observations and experiments. A law describes an observed pattern in data that occurs without any known exception. A law that has withstood the test of time is incorporated into the field of knowledge. Because they explain the patterns described in laws, theories can be used to predict future events.

One example of a scientific law was discovered around the 1800s by a group of scientists who were working with gases to, among other reasons, improve the design of the hot air balloon. After many tests, Jacques Charles and other scientists discovered that patterns and regularities existed in their observations of gas behavior. They found that if the temperature of the gas increased, the volume of the gas also increased. This relationship has held true over time and is now a scientific law. Any scientific theory that describes gas behavior would need to reflect this law and predict that the volume of a gas increases whenever the temperature increases.

Around the same time, another scientist named J. W. Henry was trying to find a pattern between the pressure of a gas and the amount of the gas dissolved in water. Henry found that when one of these variables increased, the other variable increased in the same proportion. If you have ever gone scuba diving, you may already be familiar with this observation. During training, scuba divers learn about a problem known as “the bends.” As scuba divers dive deeper, the increased pressure of the air they breathe causes more nitrogen to be dissolved in the diver’s blood. Coming up too quickly from a dive causes the pressure to decrease rapidly and the nitrogen to leave the blood quickly, which

could lead to joint pains known as “the bends.” Henry’s Law is a scientific law because it indicates a repeatedly observed relationship (regularity) between gas pressure and the amount of dissolved gas.

In this video a teacher discusses the difference between a theory and a law (**1f - IE Stand.**): <http://www.youtube.com/watch?v=eDED5fCY86s> (4:18).

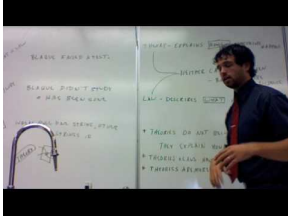

MEDIA

Click image to the left for more content.

Experimentation

The scientific method requires that observations be made. Sometimes the phenomenon we wish to observe does not occur in nature or is inconvenient for us to observe. If we can arrange for the phenomenon to occur at our convenience, we can control other variables and have all of our measuring instruments on hand to help us make observations. An **experiment** is a controlled method of testing a hypothesis under the conditions we want at a time and place of our choosing. When scientists conduct experiments, they are usually seeking new information or trying to verify someone else’s data. In comparison, classroom experiments often demonstrate and verify information that is already known to scientists but may be new to students.

Suppose a scientist observed two pools of water in bowl-shaped rocks that are located near each other while walking along the beach on a very cold day following a rainstorm. One of the pools was partially covered with ice, while the other pool had no ice on it. The unfrozen pool seemed to contain seawater that splashed up on the rock from the surf, but the other pool was too high up for seawater to splash in and was most likely filled with only rainwater.

Since both pools were at the same temperature, the scientist wondered why one pool was partially frozen and the other was not. By tasting the water (not a good idea), the scientist determined that the unfrozen pool tasted saltier than the partially frozen one. The scientist thought perhaps salt water had a lower freezing point than fresh water, so she decided to go home to test her hypothesis. In order to test this hypothesis, the scientist will conduct an experiment during which she can make accurate observations. So far, the scientist has identified a question, gathered a small amount of data, and suggested a hypothesis.

For the experiment, the scientist prepared two identical containers of fresh water and added some salt to one of them. A thermometer was placed in each container, and both containers were placed in a freezer. The scientist then observed the conditions and temperatures of the two liquids at regular intervals (see the tables below).

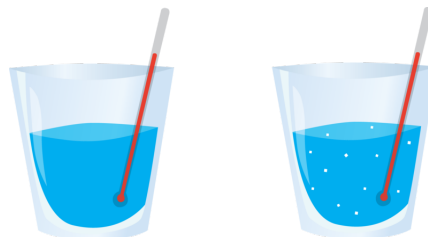

**Temperature and Conditions of
Fresh Water**

**Temperature and Conditions of
Salt Water**

time (min)	temperature (°C)	condition	time (min)	temperature (°C)	condition
0	25	liquid	0	25	liquid
5	20	liquid	5	20	liquid
10	15	liquid	10	15	liquid
15	10	liquid	15	10	liquid
20	5	liquid	20	5	liquid
25	0	frozen	25	0	liquid
30	-5	frozen	30	-5	frozen

The scientist found support for her hypothesis from this experiment: fresh water freezes at a higher temperature than salt water. Much more support would be needed before the scientist is confident in this hypothesis. She would perhaps ask other scientists to verify the work.

In the scientist's experiment, it was necessary that she freeze the salt water and fresh water under exactly the same conditions. Why? The scientist was testing whether or not the presence of salt in water would alter its freezing point. It is known that even changing the air pressure will alter the freezing point of water. In order to conclude that the presence of the salt was what caused the change in freezing point, all other conditions had to be identical. When doing an experiment, it is important to set up the experiment so that relationships can be seen clearly. A **controlled experiment** is one that compares the results of an experimental sample to a control sample. The control sample is identical to the experimental sample in all ways except for the one variable being tested. The fresh water sample is the control sample, while the sample containing salt is the experimental sample. The presence of salt is the only thing allowed to change in the two samples and is the effect being tested. In an experiment, there may be only one variable, and the purpose of the control is to guarantee that there is only one variable. Unless experiments are controlled, the results are not valid.

Suppose you wish to determine which brand of microwave popcorn leaves the fewest unpopped kernels. You will need a supply of various brands of microwave popcorn to test, and you will need a microwave oven. If you used different brands of microwave ovens with different brands of popcorn, the percentage of unpopped kernels could be caused by the different brands of popcorn or by the different brands of ovens. Under such circumstances, the experimenter would be unable to conclude confidently whether the popcorn or the oven caused the difference. To eliminate this problem, you must use the same microwave oven for every test. In order to reasonably conclude that the change in one variable was caused by the change in another specific variable, there must be no other variables in the experiment. By using the same microwave oven, you control the number of variables in the experiment.

This video presents both how errors can occur and how to avoid them when conducting experiments in the laboratory (**1b, 1c, 1j IE Stand.**): <http://www.youtube.com/watch?v=RUIDZeqY4To> (3:57).



MEDIA

Click image to the left for more content.

Scientific Models

Chemists rely on both careful observation and well-known physical laws. By putting observations and laws together, chemists develop models. A **model** is a descriptive, graphic, or three-dimensional representation of a hypothesis or theory used to help enhance understanding. Scientists often use models when they need a way to communicate their understanding of what might be very small (such as an atom or molecule) or very large (such as the universe).

A model is any simulation, substitute, or stand-in for what you are actually studying and provide a way of predicting what will happen given a certain set of circumstances. A good model contains the essential variables that you are concerned with in the real system, explains all the observations on the real system, and is as simple as possible. A model may be as uncomplicated as a sphere representing the earth or billiard balls representing gaseous molecules, but it may also be as complex as mathematical equations representing light.

If you were asked to determine the contents of a box that cannot be opened, you could do a variety of experiments in order to develop an idea (or a model) of what the box contains. You would probably shake the box, perhaps put magnets near it, and possibly determine its mass. When you completed your experiments, you would develop an idea of what is inside; that is, you would propose a model of what is inside the box that cannot be opened. With your model, you could predict how the unopened box would behave under a different set of conditions.

However, even though your model may be capable of accurately predicting some behavior of the unopened box, you would find that the model does not always agree with new experimental results and observations. The model is only be as good as the data you have collected. Because you would never be able to open the box to see what is inside, you also would never be able to create a perfectly accurate model of the box. The model can only be modified and refined with further experimentation.

Chemists have created models about what happens when different chemicals are mixed together, heated up, cooled down, or compressed by using many observations from past experiments. They use these models to predict what might happen during future experiments. Once chemists have models that predict the outcome of experiments reasonably well, those working models can be applied for practical purposes, such as producing an especially strong plastic or detecting potential toxins in your food.

A good example of how a model is useful to scientists is to examine how models were used to develop the atomic theory. As you will learn in the chapter “The Atomic Theory,” the concept of an atom has changed over many years. In order to understand the different theories of atomic structure proposed by various scientists, models were drawn to make the concepts easier to understand.

Lesson Summary

- The scientific method is a method of investigation involving experimentation and observation to acquire new knowledge, solve problems, and answer questions.
- The steps in the scientific method are:
 1. Identify the problem.
 2. Gather data (make observations).
 3. Suggest a hypothesis.
 4. Test the hypothesis (experiment).
 5. Accept the hypothesis for further testing, or reject the hypothesis and make a new one.
- A hypothesis is a tentative explanation that can be tested by further investigation.
- A theory is an explanation that summarizes a hypothesis or a set of hypotheses and has been supported with repeated testing.
- A scientific law is a statement that summarizes the results of many observations and experiments.
- An experiment is a controlled method of testing a hypothesis.
- A controlled experiment is one that compares the results of an experimental sample to a control sample.
- The control sample is identical to the experimental sample in all ways except for the one variable whose effect is being tested.
- A model is a descriptive, graphic, or three-dimensional representation of a hypothesis or theory used to help enhance understanding.
- Scientists often use models when they need a way to communicate their understanding of what might be very small (such as an atom or molecule) or very large (such as the universe).

Further Reading / Supplemental Links

The *learner.org* website allows users to view the Annenberg series of chemistry videos. You are required to register before you can watch the videos, but there is no charge to register. The website has two videos that apply to this lesson. One video called “Thinking Like Scientists” relates to the scientific method. The other video is called “Modeling the Unseen.”

- <http://learner.org/resources/series61.html>

This website has a video that explores the history of the scientific method.

- <http://videos.howstuffworks.com/hsw/5881-scientific-method-history-video.htm>

This video is a ChemStudy film called “High Temperature Research.” The film is somewhat dated but the information is accurate.

- <http://www.youtube.com/watch?v=Tt2JEwbOtq8>

Review Questions

Use the following paragraph to answer questions 1 and 2.

In 1928, Sir Alexander Fleming was studying *Staphylococcus* bacteria growing in culture dishes. He noticed that a mold called *Penicillium* was also growing in some of the dishes. As shown in the illustration below, Petri dish A represents a dish containing only *Staphylococcus* bacteria. In dishes containing the *Penicillium* mold, represented by Petri dish B below, Fleming noticed that a clear area existed around the mold because all the bacteria in this area had died. In the culture dishes without the mold, no clear areas were present. Fleming suggested that the mold was producing a chemical that killed the bacteria. He decided to isolate this substance and test it to see if it would kill bacteria. Fleming grew some *Penicillium* mold in a nutrient broth. After the mold grew in the broth, he removed all the mold from the broth and added the broth to a culture of bacteria. All the bacteria died.

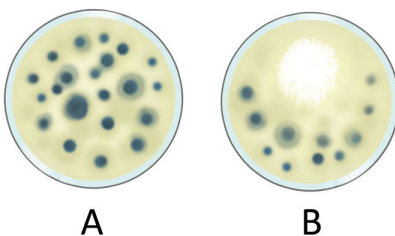

1. Which of the following statements is a reasonable expression of Fleming’s hypothesis?
 - a. Nutrient broth kills bacteria.
 - b. There are clear areas around the *Penicillium* mold where *Staphylococcus* doesn’t grow.
 - c. Mold kills bacteria.
 - d. *Penicillium* mold produces a substance that kills *Staphylococcus*.
 - e. Without mold in the culture dish, there were no clear areas in the bacteria.
2. Fleming grew *Penicillium* in broth, removed the *Penicillium*, and poured the broth into culture dishes containing bacteria to see if the broth would kill the bacteria. What step in the scientific method does this represent?

- a. Collecting and organizing data
 - b. Making a hypothesis
 - c. Testing a hypothesis by experiment
 - d. Rejecting the old hypothesis and making a new one
 - e. None of these
3. A scientific investigation is *not* valid unless every step in the scientific method is present and carried out in the exact order listed in this chapter.
- a. True
 - b. False
4. Which of the following is closest in meaning to the word “hypothesis”?
- a. Fact
 - b. Law
 - c. Formula
 - d. Suggested explanation
 - e. Conclusion
5. Why do scientists sometimes discard theories?
- a. The steps in the scientific method were not followed in order.
 - b. Public opinion disagrees with the theory.
 - c. The theory is opposed by the church.
 - d. Contradictory observations are found.
 - e. Congress voted against it.

Use the following paragraph to answer questions 6 through 10.

Gary noticed that two plants of the same type were different in size after three weeks, even though they were initially the same size when his mother planted them on the same day. Since the larger plant was in the full sun all day and the smaller plant was in the shade of a tree for most of the day, Gary believed that the sunshine was responsible for the difference in plant size. In order to test this, Gary bought ten small plants of the same size and type. He also made sure they have the same amount and type of soil. Gary then built a frame to hold a canvas roof over five of the plants, while the other five were nearby but out in the sun. Gary was careful to make sure that each plant received exactly the same amount of water and plant food every day.

6. Which of the following is a reasonable statement of Gary’s hypothesis?
- a. Different plants have different characteristics.
 - b. Plants that get more sunshine grow larger than plants that get less sunshine.
 - c. Plants that grow in the shade grow larger.
 - d. Plants that don’t receive water will die.
 - e. Plants that receive the same amount of water and plant food will grow the same amount.
7. What scientific reason might Gary have for insisting that the container size for the all plants be the same?
- a. Gary wanted to determine if the size of the container would affect the plant growth.
 - b. Gary wanted to make sure the size of the container did not affect differential plant growth in his experiment.
 - c. Gary wanted to control how much plant food his plants received.
 - d. Gary wanted his garden to look organized.
 - e. There is no possible scientific reason for having the same-sized containers.
8. What scientific reason might Gary have for insisting that all plants receive the same amount of water every day?
- a. Gary wanted to test the effect of shade on plant growth, and therefore he wanted to have no variables other than the amount of sunshine on the plants.

- b. Gary wanted to test the effect of the amount of water on plant growth.
 - c. Gary's hypothesis was that water quality was affecting plant growth.
 - d. Gary was conserving water.
 - e. There is no possible scientific reason for having the same amount of water for each plant every day.
9. What was the variable being tested in Gary's experiment?
- a. The amount of water
 - b. The amount of plant food
 - c. The amount of soil
 - d. The amount of sunshine
 - e. The type of soil
10. Which of the following factors did Gary not control in his experimental setup that may be varying?
- a. Individual plant variation
 - b. Soil temperature due to the different colors of the containers
 - c. Water loss due to evaporation from the soil
 - d. The effect of insects, which may attack one set of plants but not the other
 - e. All of the above are possible factors that Gary did not control
11. When a mosquito sucks blood from its host, it penetrates the skin with its sharp beak and injects an anti-coagulant so that the blood will not clot. It then sucks some blood and removes its beak. If the mosquito carries disease-causing microorganisms, it injects these into its host along with the anti-coagulant. It was assumed for a long time that the typhus virus was injected by the louse (singular for lice) when sucking blood in a manner similar to the mosquito. This turned out not to be true. The infection is not in the saliva of the louse but in the feces. The disease is thought to be spread when louse feces come in contact with scratches or bite wounds on the host's skin. A test of this was carried out in 1922 when two workers fed infected lice on a monkey, taking great care that no louse feces came into contact with the monkey. After two weeks, the monkey had *not* become ill with typhus. The workers then injected the monkey with typhus, and the monkey became ill within a few days. Why did the workers inject the monkey with typhus near the end of the experiment?
- a. To prove that the lice carried the typhus virus
 - b. To prove the monkey was similar to man
 - c. To prove that the monkey was not immune to typhus
 - d. To prove that mosquitoes were not carriers of typhus
 - e. To demonstrate that the workers were mean
12. When a theory has been known for a long time, it becomes a law.
- a. True
 - b. False
13. During Pasteur's time, anthrax was a widespread and disastrous disease for livestock. Many people whose livelihood was raising livestock lost large portions of their herds to this disease. Around 1876, a horse doctor in eastern France named Louvrier claimed to have invented a cure for anthrax. The influential men of the community supported Louvrier's claim of having cured hundreds of cows of anthrax. Pasteur went to Louvrier's hometown to evaluate the cure. The cure was explained to Pasteur as a multi-step process during which: 1) the cow was rubbed vigorously to make her as hot as possible; 2) long gashes were cut into the cow's skin; 3) turpentine was poured into the cuts; 4) an inch-thick coating of cow manure mixed with hot vinegar was plastered onto the cow; and 5) the cow was completely wrapped in a cloth. Since some cows recover from anthrax with no treatment, performing the cure on a single cow would not be conclusive, so Pasteur proposed an experiment to test Louvrier's cure. Four healthy cows were to be injected with anthrax microbes. After the cows became ill, Louvrier would pick two of the cows (A and B) and perform his cure on them, while the other two cows (C and D) would be left untreated. The experiment was performed, and after a few days, one of the untreated cows died and the other got better. Of the cows treated by Louvrier's cure, one cow died and the other got better. In this experiment, what was the purpose of infecting cows C and D?

- a. To give Louvrier more than two cows to choose from
 - b. To make sure the injection actually contained anthrax
 - c. To serve as experimental controls (a comparison of treated to untreated cows)
 - d. To kill as many cows as possible
14. A hypothesis is:
- a. a description of a consistent pattern in observations.
 - b. an observation that remains constant.
 - c. a theory that has been proven.
 - d. a tentative explanation for a phenomenon.
15. A scientific law is:
- a. a description of a consistent pattern in observations.
 - b. an observation that remains constant.
 - c. a theory that has been proven.
 - d. a tentative explanation for a phenomenon.
16. A number of people became ill after eating oysters in a restaurant. Which of the following statements is a hypothesis about this occurrence?
- a. Everyone who ate oysters got sick.
 - b. People got sick whether the oysters they ate were raw or cooked.
 - c. Symptoms included nausea and dizziness.
 - d. The cook felt really bad about it.
 - e. Bacteria in the oysters may have caused the illness.
17. Which statement best describes the reason for using experimental controls?
- a. Experimental controls eliminate the need for large sample sizes.
 - b. Experimental controls eliminate the need for statistical tests.
 - c. Experimental controls reduce the number of measurements needed.
 - d. Experimental controls allow comparison between groups that are different in only one variable.
18. A student decides to set up an experiment to determine the relationship between the growth rate of plants and the presence of detergent in the soil. He sets up ten seed pots. In five of the seed pots, he mixes a precise amount of detergent with the soil. The other five seed pots have no detergent in the soil. The five seed pots with detergent are placed in the sun, and the five seed pots with no detergent are placed in the shade. All ten seed pots receive the same amount of water as well as the same number and type of seeds. He grows the plants for two months and charts the growth every two days. What is wrong with his experiment?
- a. The student has too few pots.
 - b. The student has two variables different between the groups.
 - c. The student did not add detergent to all ten pots.
 - d. The student has no experimental control on the soil.
19. A scientist plants two rows of corn for experimentation. She puts fertilizer on row 1 but does not put fertilizer on row 2. Both rows receive the same amount of sun and water. She checks the growth of the corn over the course of five months. What is acting as the control in this experiment?
- a. The corn without fertilizer
 - b. The corn with fertilizer
 - c. The amount of water
 - d. The height of the corn plants
20. If you have a control group for your experiment, which of the following is true?
- a. There can be more than one difference between the control group and the test group but no more than three differences, or else the experiment is invalid.
 - b. The control group and the test group may have many differences between them.

- c. The control group must be identical to the test group except for one variable.
 - d. None of these are true.
21. If the hypothesis is rejected by the experiment, then:
- a. the experiment may have been a success.
 - b. the experiment was a failure.
 - c. the experiment must be poorly designed.
 - d. the experiment didn't follow the scientific method.
22. A well-substantiated explanation of an aspect of the natural world is a:
- a. theory.
 - b. law.
 - c. hypothesis.
 - d. none of the above.

All images, unless otherwise stated, are created by CK-12 Foundation and are under the Creative Commons license CC-BY-NC-SA.

1.3 References

1. Joseph Wright of Derby. [The Alchemist, In Search of the Philosopher's Stone](#). Public domain
2. Line engraving by Louis Delaistre, after a design by Julien Boilly. [Antoine Lavoisier, The Father of Modern Chemistry](#). Public domain
3. Cjp24. [Some common objects made of plastic](#). Public domain

CHAPTER **2** Measurement in Chemistry

Chapter Outline

- 2.1 MAKING OBSERVATIONS**
 - 2.2 MEASUREMENT SYSTEMS**
 - 2.3 THE SI SYSTEM OF MEASUREMENT**
 - 2.4 SIGNIFICANT FIGURES**
 - 2.5 USING ALGEBRA IN CHEMISTRY**
 - 2.6 SCIENTIFIC NOTATION**
 - 2.7 EVALUATING MEASUREMENTS**
 - 2.8 GRAPHING**
 - 2.9 REFERENCES**
-

2.1 Making Observations

Lesson Objectives

The student will:

- explain the importance of observations.
- define qualitative and quantitative observations.
- distinguish between qualitative and quantitative observations.
- explain the importance of using quantitative observations in measurements where possible.

Vocabulary

- observation
- qualitative observation
- quantitative observation

Introduction

Observation is very important when using scientific methods to investigate phenomena. **Observation** involves using the senses to gather information about the natural world. Science depends on keeping records of observations for later interpretations. These interpretations may lead to the development of scientific theories or laws. Without accurate observations, scientists cannot make any interpretations and therefore cannot draw conclusions.

Take out a piece of paper and record a chart similar to the one shown in **Table 2.1**. A chart is a useful tool that can help us record and organize our observations. Look up from this text and scan the room. Write down what you see around you in as much detail as you feel necessary in order for you or someone else to picture the room.

TABLE 2.1: Record of Observations

Item	Observation
1.	
2.	
3.	

One summer evening, Scott and Brenda came home from work to find their house in shambles. Neighbors, friends, and colleagues were baffled by the strange occurrence. Inside the house, they found the television turned on. Food on the table was ready to be eaten. All of Scott's coin collections, his precious metals, and Brenda's prized possession – her statue of Galileo – were gone. Foul play is suspected.

Here is a simple test for you. Pretend you are visiting a forensic scientist, hired to investigate the scene of the crime. You are asked to only analyze the observations gathered by the other investigators at the scene. You must try to make

as few assumptions as possible and make your decision based on the data at hand. The lead investigator gives you the following observations gathered from the scene and the suspects:

Observations at Scene

1. Blood type = B
2. Fiber sample = polyester
3. Powder found = white
4. Shoe print found = work boot

TABLE 2.2: Suspect Information

Suspect 1: 180 lb male	Suspect 2: 220 lb male	Suspect 3: 120 lb female
Blood type = B	Blood type = B	Would not comply
Sweater = polyester	Blazer = wool knit	Pants = polyester
Works in sugar factory	Pastry chef	Automobile sales woman

From **Table 2.2**, can you deduce who might have been involved in the alleged crime? Do you need more information? How detailed do the observations need to be in order for you, the scientist, to make accurate conclusions? What will you base your decision on? What other information do you need? Remember that if you guess randomly, an innocent person could be convicted.

Quantitative and Qualitative Observations Defined

There are two types of observations: quantitative and qualitative. **Quantitative observations** involve measurements or estimates that yield meaningful, numerical results. **Qualitative observations** yield descriptive, nonnumerical results. Although all the observations we can make on a phenomenon are valuable, quantitative observations are often more helpful than qualitative ones. Qualitative observations are somewhat vague because they involve comparative terms. Quantitative observations, on the other hand, have numbers and units associated with them and therefore convey more information. Even an estimated number is more valuable than no number at all.

A qualitative observation would be, for example, “The attendance clerk is a small woman.” If the observer is 6 feet 4 inches tall, he might find a woman who is 5 feet 8 inches tall to be “small.” If the observer reported this to someone who is 5 feet 2 inches tall, however, the listener would not acquire a good idea of the attendance clerk’s height because he would not think a woman who is 5 feet 8 inches tall is small. The description “a small woman” could refer to any woman whose height was between 3 feet and 6 feet, depending on who made the observation, as illustrated in the image below.

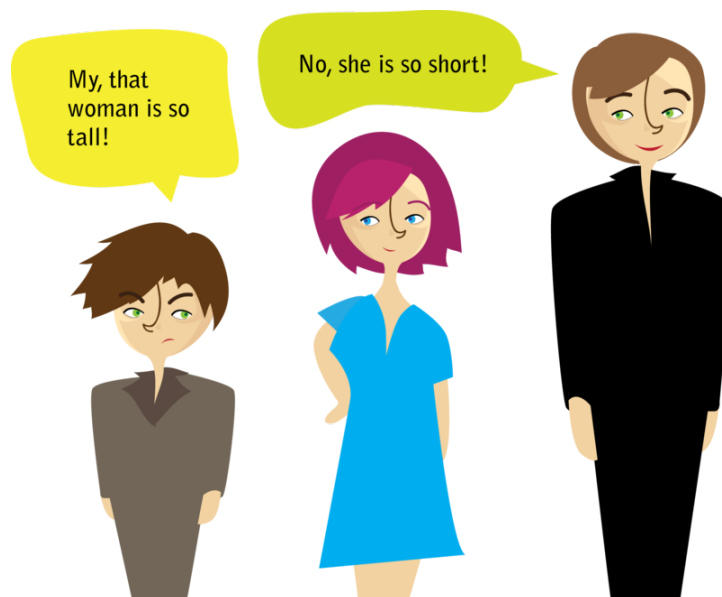

Similarly, “a small car” could refer to anything from a compact car to a child’s toy car. The word “small” is a comparative term. The same is true for all words like tall, short, fast, slow, hot, cold, and so forth. These words do not have exact meanings. Under various circumstances, temperatures of 90°F, 110°F, 212°F, and 5000°F could all be described as “hot.” The word “hot” does not convey as much information as the numerical description. Even observations of colors are not exact because there are many shades of each color. Two people may both be wearing red shirts, but the colors of the shirts may not be exactly the same. Exact descriptions of colors would require reporting the frequency or wavelength of the color.

Quantitative and Qualitative Observations Compared

TABLE 2.3: Comparison of Qualitative and Quantitative Observations

Qualitative (words only)

The girl has very little money.
 The man is short.
 Use a small test tube.
 It is a short walk to my house.

Quantitative (words and numbers)

The girl has 85 cents.
 The man is 5 feet 2 inches tall.
 Use a test tube that is 12 centimeters long.
 It is about 1 mile to my house.

You can see from the last example in **Table 2.3** that even if the number is an estimate, a quantitative observation contains more information because of the number associated with the observation. Some people might think that a 1-mile walk is short, while others may not. If an actual measuring device is not available, the observer should always try to estimate a measurement so that the observation will have a number associated with it.

While estimated measurements may not be accurate, they are valuable because they establish an approximate numerical description for the observation. “The car is small” is an observation that provides us with certain information. We know that the object is some kind of car (perhaps real or perhaps a toy), and we know that it is probably smaller than a limousine because almost no one would describe a limousine as small. Suppose instead that the observation is: “The car is about 3 feet tall, 3 feet long, and 2 feet wide.” While these estimated measurements are not accurate, we now know that we are not dealing with a compact automobile, nor are we dealing with a toy car. With these estimated measurements, we know that we are dealing with a car about the size of a tricycle. It is not a problem if we discover later that the car was actually 2 feet tall instead of 3 feet tall, because we knew the original

measurement was an estimate. Estimates are excellent observations if we do not have the ability to measure the object accurately and still qualify as quantitative observations.

Example Questions:

Pick out the quantitative and qualitative observations from each phrase.

1. 3.0 grams of NaCl dissolve in 10 milliliters of H₂O to produce a clear solution.
2. The spider on the wall has only seven legs remaining but is still big and hairy.
3. When 0.50 milliliter of a solution is put into a flame, the flame turns a brilliant green.

Solutions:

1. Quantitative: 3.0 grams and 10 milliliters; Qualitative: clear solution
2. Quantitative: seven legs; Qualitative: big and hairy
3. Quantitative: 0.50 milliliter; Qualitative: brilliant green

Lesson Summary

- Observation involves using the senses to gather information about the natural world.
- There are two types of observations: qualitative and quantitative.
- Scientists gather information by making both qualitative and quantitative observations.
- Qualitative observations yield descriptive, nonnumerical results.
- Quantitative observations yield meaningful, numerical results.
- Observations, either qualitative or quantitative, are used by scientists as tools to make representations and interpretations about the surroundings.

Further Reading / Supplemental Links

This website helps to build your observation skills.

- <http://www.mrsoshouse.com/pbl/observe/indexobserve.htm>

Review Questions

Label each observation as qualitative or quantitative.

1. The temperature of this room is 25°C.
2. It is comfortably warm in this room.
3. Most people have removed their coats.
4. The building is 25 stories high.
5. It is a very tall building.
6. The building is taller than any nearby trees.
7. The bottle is green.
8. The bottle contains 250 milliliters of liquid.
9. Robert bought his son a small car.

10. The car is smaller than his hand.
11. The car is about three inches long.
12. The race is about 27 miles long.

2.2 Measurement Systems

Lesson Objectives

The student will:

- state an advantage of using the metric system over the United States customary system.
- state the different prefixes used in the metric system.

Vocabulary

- base unit
- metric system

Introduction

Even in ancient times, humans needed measurement systems for commerce. Land ownership required measurements of length, and the sale of food and other commodities required measurements of mass. The first elementary efforts in measurement required convenient objects to be used as standards, such as the human body. Inch and foot are examples of measurement units that are based on parts of the human body. The inch is based on the width of a man's thumb, and the foot speaks for itself. The grain is a unit of mass measurement that is based upon the mass of a single grain of wheat. Because grains of wheat are fairly consistent in mass, the quantity of meat purchased could be balanced against some number of grains of wheat on a merchant's balance.

It should be apparent that measuring the foot of two different people would lead to different results. One way to achieve greater consistency was for everyone to use the foot of one person, such as the king, as the standard. The length of the king's foot could be marked on pieces of wood, and everyone who needed to measure length could have a copy. Of course, this standard would change when a new king was crowned.

What were needed were objects that could be safely stored without changing over time to serve as standards of measurement. Copies of these objects could then be made and distributed so that everyone was using the exact same units of measure. This was especially important when the requirements of science necessitated accurate, reproducible measurements.

The Metric System

The **metric system** is an international decimal-based system of measurement. Because the metric system is a decimal system, making conversions between different units of the metric system are always done with factors of ten. To understand why this makes the metric system so useful and easy to manipulate, let's consider the United States customary system – that is, the measurement system commonly used in the US. For instance, if you need to

know how many inches are in a foot, you need to remember: 12 inches = 1 foot. Now imagine that you now need to know how many feet are in a mile. What happens if you have never memorized this fact before? Of course, you can find this conversion online or elsewhere, but the point is that this information must be given to you, as there is no way for you to derive it by yourself. This is true about all parts of the United States customary system: you have to memorize all the facts that are needed for different measurements.

Metric Prefixes and Equivalents

The metric system uses a number of prefixes along with the base units. A **base unit** is one that cannot be expressed in terms of other units. The base unit of mass is the gram (g), that of length is the meter (m), and that of volume is the liter (L). Each base unit can be combined with different prefixes to define smaller and larger quantities. When the prefix “centi-” is placed in front of gram, as in centigram, the unit is now $\frac{1}{100}$ of a gram. When “milli-” is placed in front of meter, as in millimeter, the unit is now $\frac{1}{1,000}$ of a meter. Common prefixes are shown in **Table 2.4**.

TABLE 2.4: Common Prefixes

Prefix	Meaning	Symbol
pico-	10^{-12}	p
nano-	10^{-9}	n
micro-	10^{-6}	μ (pronounced <i>mu</i>)
milli-	10^{-3}	m
centi-	10^{-2}	c
deci-	10^{-1}	d
kilo-	10^3	k

Common metric units, their symbols, and their relationships to a base unit are shown below:

$$\begin{aligned}
 1.00 \text{ picogram} &= 1.00 \text{ pg} = 1.00 \times 10^{-12} \text{ g} \\
 1.00 \text{ nanosecond} &= 1.00 \text{ ns} = 1.00 \times 10^{-9} \text{ s} \\
 1.00 \text{ micrometer} &= 1.00 \text{ }\mu\text{m} = 1.00 \times 10^{-6} \text{ m} \\
 1.00 \text{ centimeter} &= 1.00 \text{ cm} = 1.00 \times 10^{-2} \text{ m} \\
 1.00 \text{ deciliter} &= 1.00 \text{ dL} = 1.00 \times 10^{-1} \text{ L} \\
 1.00 \text{ kilogram} &= 1.00 \text{ kg} = 1.00 \times 10^3 \text{ g}
 \end{aligned}$$

You can express a given measurement in more than one unit. If you express a measured quantity in two different metric units, then the two measurements are metric equivalents. Common metric equivalents are shown below.

- Length:

$$\begin{aligned}
 1,000 \text{ millimeters} &= 1 \text{ meter} \\
 100 \text{ centimeters} &= 1 \text{ meter} \\
 10 \text{ millimeters} &= 1 \text{ centimeter}
 \end{aligned}$$

- Mass:

$$\begin{aligned}
 1,000 \text{ milligrams} &= 1 \text{ gram} \\
 1,000 \text{ grams} &= 1 \text{ kilogram}
 \end{aligned}$$

- Volume:

$$1 \text{ liter} = 1,000 \text{ milliliters}$$

Lesson Summary

- The metric system is an international decimal-based system of measurement.
- The metric system uses a number of prefixes along with the base units.
- The prefixes in the metric system are multiples of 10.
- A base unit is one that cannot be expressed in terms of other units
- If you express a measured quantity in two different metric units, then the two measurements are metric equivalents.

Further Reading / Supplemental Links

The following website provides more information about the metric system and measurements in chemistry.

- http://www.chemistry24.com/teach_chemistry/measurement-and-math-in-chemistry.html

Review Questions

Fill in the blanks in **Table 2.5**.

TABLE 2.5: Table for Review Question

Prefix	Meaning	Symbol
pico-	10^{-12}	p
nano-	?	n
?	10^{-6}	μ
milli-	10^{-3}	?
centi-	?	c
deci-	10^{-1}	?
?	10^3	k

2.3 The SI System of Measurement

Lesson Objectives

The student will:

- explain the difference between mass and weight.
- identify SI units of mass, distance (length), volume, temperature, and time.
- define derived unit.
- describe absolute zero.

Vocabulary

- absolute zero
- cubic meter
- derived units
- heat
- International System of Units
- Kelvin temperature scale
- kilogram
- length
- mass
- meter
- second
- temperature
- volume
- weight

Introduction

The **International System of Units**, abbreviated SI from the French *Le Système International d' Unites*, is the main system of measurement units used in science. Since the 1960s, the International System of Units has been agreed upon internationally as the standard metric system. The SI base units are based on physical standards. The definitions of the SI base units have been and continue to be modified, and new base units are added as advancements in science are made. Each SI base unit, except the kilogram, is described by stable properties of the universe.

Mass and Its SI Unit

Mass and weight are not the same thing. Although we often use these terms interchangeably, each one has a specific definition and usage. The **mass** of an object is a measure of the amount of matter in it and remains the same regardless of where the object is placed. For example, moving a brick to the moon does not cause matter in the brick to disappear or to be removed. The **weight** of an object is the force of attraction between the object and the Earth (or whatever large, gravity-producing body the object is located on). This attraction is due to the force of gravity. Since the force of gravity is not the same at every point on the Earth's surface, the weight of an object is not constant. The gravitational pull on the object varies and depends on where the object is with respect to the Earth or other gravity-producing object. For example, a man who weighs 180 pounds on Earth would weigh only 45 pounds if he were in a stationary position 4,000 miles above the Earth's surface. This same man would weigh only 30 pounds on the moon, because the moon's gravitational pull is one-sixth that of Earth's. The mass of this man, however, would be the same in each situation because the amount of matter in the man is constant.

We measure weight with a scale, which contains a spring that compresses when an object is placed on it. An illustration of a scale is depicted on the left in the diagram below. If the gravitational pull is less, the spring compresses less and the scale shows less weight. We measure mass with a balance, depicted on the right in the diagram below. A balance compares the unknown mass to known masses by balancing them on a lever. If we take our balance and known masses to the moon, an object will have the same measured mass that it had on the Earth. The weight, of course, would be different on the moon. Consistency requires that scientists use mass and not weight when measuring the amount of matter.

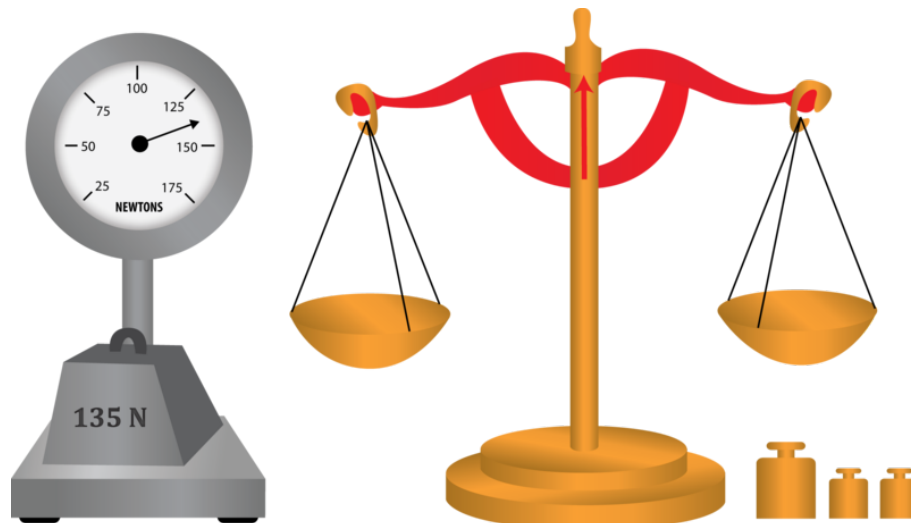

The basic unit of mass in the International System of Units is the kilogram. A **kilogram** is equal to 1,000 grams. A gram is a relatively small amount of mass, so larger masses are often expressed in kilograms. When very tiny amounts of matter are measured, we often use milligrams, with one milligram equal to 0.001 gram. Other larger, smaller, or intermediate mass units may also be appropriate.

At the end of the 18th century, a kilogram was the mass of a cubic decimeter of water. In 1889, a new international prototype of the kilogram was made from a platinum-iridium alloy. The kilogram is equal to the mass of this international prototype, which is held in Paris, France. A copy of the standard kilogram is shown in **Figure 2.1**.

**FIGURE 2.1**

This image shows a copy of the standard kilogram stored and used in Denmark.

Length and Its SI Unit

Length is the measurement of anything from end to end. In science, length usually refers to how long an object is. There are many units and sets of standards used in the world for measuring length. The ones familiar to you are probably inches, feet, yards, and miles. Most of the world, however, measure distances in meters and kilometers for longer distances, and in centimeters and millimeters for shorter distances. For consistency and ease of communication, scientists around the world have agreed to use the SI standards, regardless of the length standards used by the general public.

**FIGURE 2.2**

This image shows the standard meter used in France in the 18th century.

The SI unit of length is the **meter**. In 1889, the definition of the meter was the length of a bar made of platinum-iridium alloy stored under conditions specified by the International Bureau of Standards. In 1960, this definition of the standard meter was replaced by a definition based on a wavelength of krypton-86 radiation. In 1983, that definition was replaced by the following: the meter is the length of the path traveled by light in a vacuum during a time interval of $\frac{1}{299,792,458}$ of a second.

Volume: A Derived Unit

The **volume** of an object is the amount of space it takes up. In the International System of Units, volume is a **derived unit**, meaning that it is based on another SI unit. Consider a cube with each side measuring 1.00 meter. The volume

of this cube is $1.00\text{ m} \times 1.00\text{ m} \times 1.00\text{ m} = 1.00\text{ m}^3$, or one cubic meter. The **cubic meter** is the SI unit of volume and is based on the meter, the SI unit of length. The cubic meter is a very large unit and is not very convenient for most measurements in chemistry. A more common unit is the liter (L), which is $\frac{1}{1,000}$ of a cubic meter. One liter is slightly larger than one quart: $1.000\text{ liter} = 1.057\text{ quart}$. Another commonly used volume measurement is the milliliter, which is equal to $\frac{1}{1,000}$ of a liter. Since $\frac{1}{1,000}$ of a liter is also equal to $1.00\text{ cubic centimeter}$, then $1.00\text{ mL} = 1.00\text{ cm}^3$.

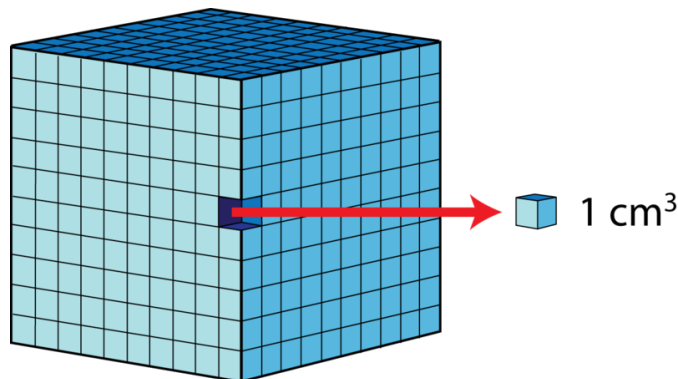

As seen in the illustration above, the volume of 1,000 blocks, each with a volume of 1 cubic centimeter, is equivalent to 1 liter.

Measuring Temperature

When used in a scientific context, the words heat and temperature do *not* mean the same thing. **Temperature** represents the average kinetic energy of the particles making up a material. Increasing the temperature of a material increases its thermal energy; objects contain thermal energy, not “heat.” **Heat** is the movement of thermal energy from a warmer object to a cooler object. When thermal energy moves from one object to another, the temperature of both objects change. These different types of energies will be re-examined in more detail in later chapters, but the key concept to remember here is that temperature reflects the thermal energy *contained* in an object, while heat is the *movement* of thermal energy between two objects.

Consider a small beaker of boiling water (100°C) and a bathtub of water at a temperature of 50°C . The amount of thermal energy contained in the bathtub is 40,000,000 joules (a measure of energy), while the amount of thermal energy in the beaker is 4,000 joules. Although the temperature of the beaker of water is only twice the temperature of the bathtub of water, the amount of thermal energy contained in the bathtub is many times greater than that in the beaker of water. The important thing to note here is that the amount of thermal energy contained in an object increases greatly with an increase in temperature.

A thermometer is a device that measures temperature. The name is made up of *thermo*, which means heat, and *meter*, which means to measure. One of the earliest inventors of a thermometer was Galileo. He is said to have used a device called a thermoscope around the year 1600. The thermometers we typically use today, however, are different from the one Galileo used.

The type of thermometers most people are familiar with operates on the principle that the volume of most liquids increases when heated and decreases when cooled. If a liquid is trapped inside an evacuated tube with an attached bulb reservoir, like that shown in the diagram below, the liquid in the tube will move higher in the tube when the liquid is heated and lower when the liquid is cooled. After a short period of time, the temperature of the liquid in the bulb will be the same temperature as the surrounding material. The liquid in the tube reflects the temperature of the surrounding because the molecules of material surrounding the bulb will collide with the tube and transfer heat during the process. If heat is transferred to the liquid in the bulb, the liquid will rise and indicate an increase

in temperature. If heat is transferred to the surrounding material, the height of the liquid in the tube will fall and indicate a decrease in temperature.

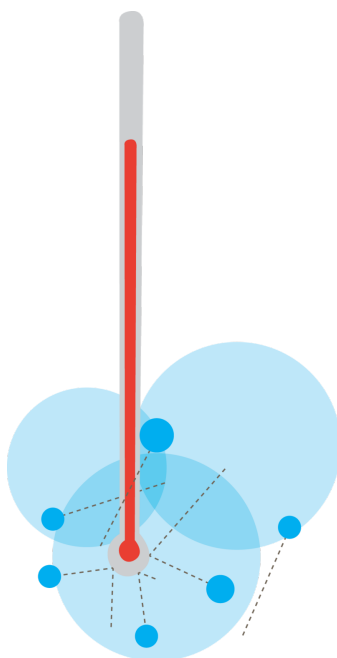

Each thermometer is calibrated by placing it in a liquid whose exact temperature is known. Most thermometers are calibrated using consistent known temperatures that are easy to reproduce. At normal sea level and atmospheric pressure, a stable mixture of ice and water will be at the freezing point of water, and a container of boiling water will be at the boiling point of water. When the height of the liquid inside the thermometer reflects the temperature of the surrounding liquid, a mark (scratch) is made on the tube to indicate that temperature. Once the freezing and boiling temperatures have been marked on the thermometer, the distance between the marks can be marked up into equal divisions called degrees.

Daniel Fahrenheit established the Fahrenheit scale. On his temperature scale, Fahrenheit designated the freezing point of water as 32°F and the boiling point of water as 212°F . Therefore, the distance between these two points would be divided into 180 degrees. The Fahrenheit temperature scale is used in the United States for most daily expressions of temperature. In another temperature scale established by Anders Celsius, Celsius designated the freezing point of water as 0°C and the boiling point of water as 100°C . Therefore, the temperatures between these two points on the Celsius scale are divided into 100 degrees. Clearly, the size of a Celsius degree and the size of a Fahrenheit degree are not the same.

Earlier in the lesson, the temperature of a substance is defined to be directly proportional to the average kinetic energy it contains. In order for the average kinetic energy and temperature of a substance to be directly proportional, it is necessary for the average kinetic energy to be zero when the temperature is zero. This is not true with either the Fahrenheit or Celsius temperature scales. Most of us are familiar with temperatures that are below the freezing point of water. It should be apparent that even though the air temperature may be -5°C , the molecules of air are still moving. Substances like oxygen and nitrogen have already become vapor at temperatures below -150°C , indicating that molecules are still in motion at over a hundred degrees below zero.

A third temperature scale was established to address this issue. This temperature scale was designed by Lord Kelvin. Lord Kelvin stated that there is no upper limit to how hot things can get, but there is a limit as to how cold things can get. Kelvin developed the idea of **absolute zero**, which is the temperature that molecules stop moving and have zero kinetic energy. The **Kelvin temperature scale** has its zero at absolute zero (determined to be -273.15°C) and uses the same degree size as a degree on the Celsius scale. As a result, the mathematical relationship between the Celsius scale and the Kelvin scale is: $\text{K} = ^{\circ}\text{C} + 273.15$. On the Kelvin scale, water freezes at 273.15 K and boils

at 373.15 K. In the case of the Kelvin scale, the degree sign is not used. Temperatures are expressed, for example, simply as 450 K.

It should be noted that many mathematical calculations in chemistry involve the difference between two temperatures, symbolized by ΔT (pronounced *delta T*). Since the size of a degree is the same in Celsius and in Kelvin, the ΔT will be the same for either scale. For example, $20^{\circ}\text{C} = 293\text{ K}$ and $50^{\circ}\text{C} = 323\text{ K}$; the difference between the Celsius temperatures is 30°C , and the difference between the Kelvin temperatures is 30 K. When the calculations involve ΔT , it is not necessary to convert Celsius to Kelvin, but when the temperature is used directly in an equation, it is necessary to convert Celsius to Kelvin.

This video is an explanation of how to convert among the Celsius, Kelvin, and Fahrenheit temperature scales and includes a sample problem (4e): <http://www.youtube.com/watch?v=SASnMMGp5mo> (4:37).

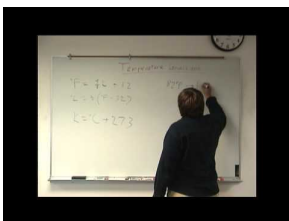

MEDIA

Click image to the left for more content.

This video is an explanation of particle temperature, average temperature, heat flow, pressure, and volume (7a): http://www.youtube.com/watch?v=tfE2y_7LqA4 (4:00).



MEDIA

Click image to the left for more content.

Time and Its SI Unit

The SI unit for time is the second. The second was originally defined as a tiny fraction of the time required for the Earth to orbit the Sun. It has since been redefined several times. The definition of a **second** (established in 1967 and reaffirmed in 1997) is: the duration of 9,192,631,770 periods of radiation corresponding to the transition between the two hyperfine levels of the ground state of the cesium-133 atom.

Lesson Summary

- The International System of Units, abbreviated SI from the French *Le Système International d' Unites*, is internationally agreed upon since the 1960s as the standard metric system.
- Mass and weight:
 - The mass of an object is a measure of the amount of matter in it.
 - The mass of an object remains the same regardless of where the object is placed.
 - The basic unit of mass in the International System of Units is the kilogram.

- The weight of an object is the force of attraction between the object and the earth (or whatever large, gravity-producing body the object is located on).
 - Length:
 - Length is the measurement of anything from end to end.
 - The SI unit of length is the meter.
 - Volume:
 - The volume of an object is the amount of space it takes up.
 - The cubic meter is the SI unit of volume.
 - Temperature and heat:
 - Temperature represents the average kinetic energy of the particles that make up a material.
 - Increasing the temperature of a material increases its thermal energy.
 - Heat is the movement of thermal energy from a warmer object to a cooler object.
 - When thermal energy moves from one object to another, the temperature of both objects change.
 - Absolute zero is the temperature at which molecules stop moving and therefore have zero kinetic energy.
 - The Kelvin temperature scale has its zero at absolute zero (determined to be -273.15°C) and uses the same degree size as the Celsius scale.
 - The mathematical relationship between the Celsius scale and the Kelvin scale is $\text{K} = ^{\circ}\text{C} + 273.15$.
 - Time:
 - The SI unit for time is the second.
-

Review Questions

1. What is the basic unit of measurement in the metric system for length?
2. What is the basic unit of measurement in the metric system for mass?
3. What unit is used in the metric system to measure volume? How is this unit related to the measurement of length?
4. Give the temperatures in Celsius for the freezing and boiling points of water.
5. Give the temperatures in Kelvin for the freezing and boiling points of water.
6. Would it be comfortable to swim in a swimming pool whose water temperature was 275 K? Why or why not?

2.4 Significant Figures

Lesson Objectives

The student will:

- explain the necessity for significant figures.
- determine significant figures of the equipment pieces chosen.
- identify the number of significant figures in a measurement.
- use significant figures properly in measurements and calculations.
- determine the number of significant figures in the result of a calculation.
- round calculated values to the correct number of significant figures.

Vocabulary

- significant figures

Introduction

The numbers you use in math class are considered to be exact numbers. When you are given the number 2 in a math problem, it does not mean 1.999 rounded up to 2, nor does it mean 2.00001 rounded down to 2. In math class, the number 2 means exactly 2.000000... with an infinite number of zeros – a perfect 2! Such numbers are produced only by definition, *not* by measurement. We can define 1 foot to contain exactly 12 inches with both numbers being perfect numbers, but we cannot measure an object to be exactly 12 inches long. In the case of measurements, we can only read our measuring instruments to a limited number of subdivisions. We are limited by our ability to see smaller and smaller subdivisions, and we are limited by our ability to construct smaller and smaller subdivisions on our measuring devices. Even with the use of powerful microscopes to construct and read our measuring devices, we eventually reach a limit. Therefore, although the actual measurement of an object may be a perfect 12 inches, we cannot prove it to be so. Measurements do not produce perfect numbers; the only perfect numbers in science are defined numbers, such as conversion factors. Since measurements are fundamental to science, science does not produce perfect measurements.

It is very important to recognize and report the limitations of a measurement along with the magnitude and unit of the measurement. Many times, the measurements made in an experiment are analyzed for regularities. If the numbers reported show the limits of the measurements, the regularity, or lack thereof, becomes visible.

TABLE 2.6: Comparison of Observations with the Proper Number of Significant Figures

Observation List A

22.41359 m
22.37899 m
22.42333 m

Observation List B

22.4 m
22.4 m
22.4 m

TABLE 2.6: (continued)

Observation List A	Observation List B
22.39414 m	22.4 m

In the lists of observations shown in **Table 2.6**, List A shows measurements without including the limits of the measuring device. In comparison, List B has the measurements rounded to reflect the limits of the measuring device. It is difficult to perceive regularity in List A, but the regularity stands out in List B.

Rules for Determining Significant Figures

Significant figures, also known as significant digits, are all of the digits that can be known with certainty in a measurement plus an estimated last digit. Significant figures provide a system to keep track of the limits of the original measurement. To record a measurement, you must write down all the digits actually measured, including measurements of zero, and you must *not* write down any digit not measured. The only real difficulty with this system is that zeros are sometimes used as measured digits, while other times they are used to locate the decimal point.

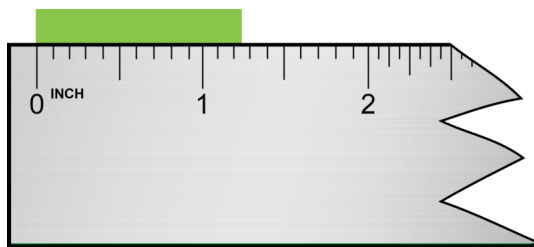

In the sketch shown above, the correct measurement is greater than 1.2 inches but less than 1.3 inches. It is proper to estimate one place beyond the calibrations of the measuring instrument. This ruler is calibrated to 0.1 inches, so we can estimate the hundredths place. This reading should be reported as 1.25 or 1.26 inches.

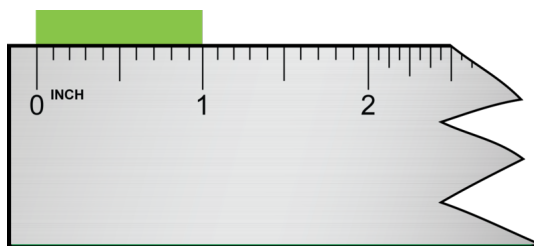

In this second case (sketch above), it is apparent that the object is, as nearly as we can read, 1 inch. Since we know the tenths place is zero and can estimate the hundredths place to be zero, the measurement should be reported as 1.00 inch. It is vital that you include the zeros in your reported measurement because these are measured places and are significant figures.

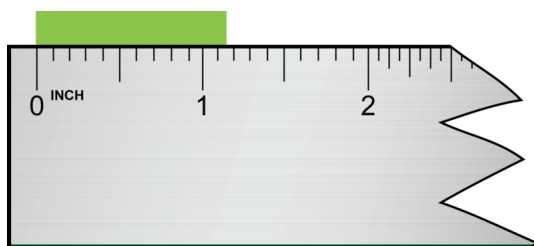

This measurement is read as 1.15 inches, 1.16 inches, or perhaps even 1.17 inches.

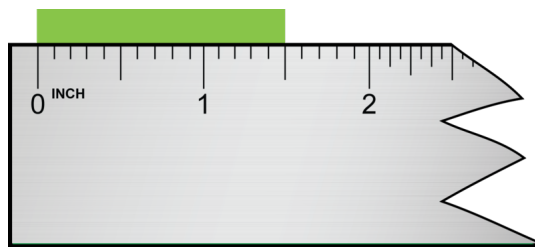

This measurement is read as 1.50 inches.

In all of these examples, the measurements indicate that the measuring instrument had subdivisions of a tenth of an inch and that the hundredths place is estimated. There is some uncertainty about the last, and only the last, digit.

In our system of writing measurements to show significant figures, we must distinguish between measured zeros and place-holding zeros. Here are the rules for determining the number of significant figures in a measurement.

Rules for Determining the Number of Significant Figures:

1. All non-zero digits are significant.
2. All zeros between non-zero digits are significant.
3. All beginning zeros are *not* significant.
4. Ending zeros are significant if the decimal point is actually written in but *not* significant if the decimal point is an understood decimal (the decimal point is not written in).

Examples of the Significant Figure Rules:

1. All non-zero digits are significant.

543 has 3 significant figures.
 22.437 has 5 significant figures.
 1.321754 has 7 significant figures.

2. All zeros between non-zero digits are significant.

7,004 has 4 significant figures.
 10.3002 has 6 significant figures.
 103 has 3 significant figures.

3. All beginning zeros are *not* significant.

0.00000075 has 2 significant figures.
 0.02 has 1 significant figure.
 0.003003 has 4 significant figures.

4. Ending zeros are significant if the decimal point is actually written in but *not* significant if the decimal point is an understood decimal.

37.300 has 5 significant figures.
 33.00000 has 7 significant figures.
 100. has 3 significant figures.
 100 has 1 significant figure.
 302,000 has 3 significant figures.
 1,050 has 3 significant figures.

Equipment Determines Significant Figures

Quality measuring instruments are made with as much consistency as possible and are individually calibrated after construction. In a graduated cylinder, for example, it is desirable for the sides to be perfectly vertical and for the inside diameter to be the same all the way up the tube. After the graduated cylinder is completed, exact volumes of liquids are placed in the cylinder and the calibration marks are then scribed onto the side of the tube.

The choice of measuring instrument determines the unit of measure and the number of significant figures in the measurement. Consider the two graduated cylinders shown below.

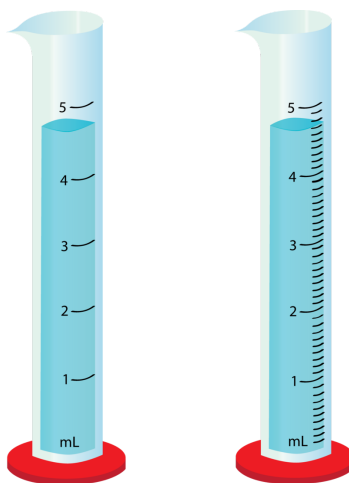

Both cylinders are marked to measure milliliters, but the cylinder on the left only shows graduations for whole milliliters. In comparison, the cylinder on the right has calibrations for tenths of milliliters. The measurer reads the volume from the calibrations and estimates one place beyond the calibrations. For the cylinder on the left, a reasonable reading is 4.5 mL. For the cylinder on the right, the measurer estimates one place beyond the graduations and obtains a reasonable reading of 4.65 mL. The choice of the measuring instrument determines both the units and the number of significant figures. If you were mixing up some hot chocolate at home, the cylinder on the left would be adequate. If you were measuring out a chemical solution for a very delicate reaction in the lab, however, you would need the cylinder on the right.

Similarly, the equipment chosen for measuring mass will also affect the number of significant figures. For example, if you use a pan balance (illustrated on the left in the image below) that can only measure to ± 0.1 g, you could only measure out 3.3 g of NaCl rather than 3.25 g. In comparison, the digital balance (illustrated on the right in the image below) might be able to measure to ± 0.01 g. With this instrument, you could measure what you need more exactly. The difference between these two balances has to do with the number of significant figures that the balances are able to measure. Whenever you need to make a measurement, make sure to check the number of significant figures a measuring instrument can measure before choosing an appropriate instrument.



Significant Figures in Calculations

In addition to using significant figures to report measurements, we also use them to report the results of computations made with measurements. The results of mathematical operations on measurements must indicate the number of significant figures in the original measurements. There are two rules for determining the number of significant figures after performing a mathematical operation. Most of the errors that occur in this area result from using the wrong rule, so always double check that you are using the correct rule for the mathematical operation involved.

Addition and Subtraction

The answer to an addition or subtraction operation must not have any digits further to the right than the shortest addend. In other words, the answer should have as many decimal places as the addend with the smallest number of decimal places.

Example:

$$\begin{array}{r} 13.3843 \text{ cm} \\ 1.012 \text{ cm} \\ + 3.22 \text{ cm} \\ \hline 17.6163 \text{ cm} = 17.62 \text{ cm} \end{array}$$

Notice that the top addend has a 3 in the last column on the right, but neither of the other two addends have a number in that column. In elementary math classes, you were taught that these blank spaces can be filled in with zeros and the answer would be 17.6163 cm. In the sciences, however, these blank spaces are unknown numbers, *not* zeros. Since they are unknown numbers, you cannot substitute any numbers into the blank spaces. As a result, you cannot know the sum of adding (or subtracting) any column of numbers that contain an unknown number. When you add the columns of numbers in the example above, you can only be certain of the sums for the columns with known numbers in each space in the column. In science, the process is to add the numbers in the normal mathematical process and then round off all columns that contain an unknown number (a blank space). Therefore, the correct answer for the example above is 17.62 cm and has only four significant figures.

Example:

$$\begin{array}{r} 12 \text{ m} \\ + 0.00045 \text{ m} \\ \hline 12.00045 \text{ m} = 12 \text{ m} \end{array}$$

In this case, the addend 12 has no digits beyond the decimal. Therefore, all columns past the decimal point must be rounded off in the final answer. We get the seemingly odd result that the answer is still 12, even after adding a number to 12. This is a common occurrence in science and is absolutely correct.

Example:

$$\begin{array}{r} 56.8885 \text{ cm} \\ 8.30 \text{ cm} \\ + 47.0 \text{ cm} \\ \hline 112.1885 \text{ cm} = 112.2 \text{ cm} \end{array}$$

Multiplication and Division

The answer for a multiplication or division operation must have the same number of significant figures as the factor with the least number of significant figures.

Example:

$$(3.556 \text{ cm}) \cdot (2.4 \text{ cm}) = 8.5344 \text{ cm}^2 = 8.5 \text{ cm}^2$$

The factor 3.556 cm has four significant figures, and the factor 2.4 cm has two significant figures. Therefore the answer must have two significant figures. The mathematical answer of 8.5344 cm² must be rounded back to 8.5 cm² in order for the answer to have two significant figures.

Example:

$$(20.0 \text{ cm}) \cdot (5.0000 \text{ cm}) = 100.00000 \text{ cm}^2 = 100. \text{ cm}^2$$

The factor 20.0 cm has three significant figures, and the factor 5.0000 cm has five significant figures. The answer must be rounded to three significant figures. Therefore, the decimal must be written in to show that the two ending zeros are significant. If the decimal is omitted (left as an understood decimal), the two zeros will not be significant and the answer will be wrong.

Example:

$$(5.444 \text{ cm}) \cdot (22 \text{ cm}) = 119.768 \text{ cm}^2 = 120 \text{ cm}^2$$

In this case, the answer must be rounded back to two significant figures. We cannot have a decimal after the zero in 120 cm² because that would indicate the zero is significant, whereas this answer must have exactly two significant figures.

Lesson Summary

- Significant figures are all of the digits that can be known with certainty in a measurement plus an estimated last digit.
- Significant figures provide a system to keep track of the limits of a measurement.
- Rules for determining the number of significant figures:
 1. All non-zero digits are significant.
 2. All zeros between non-zero digits are significant.
 3. All beginning zeros are *not* significant.
 4. Ending zeros are significant if the decimal point is actually written in but *not* significant if the decimal point is an understood decimal.
- The choice of measuring instrument is what determines the unit of measure and the number of significant figures in the measurement.
- The results of mathematical operations must include an indication of the number of significant figures in the original measurements.
- The answer for an addition or subtraction operation must not have any digits further to the right than the shortest addend.
- The answer for a multiplication or division operation must have the same number of significant figures as the factor with the least number of significant figures.

Further Reading / Supplemental Links

A problem set on unit conversions and significant figures.

- <http://science.widener.edu/svb/pset/convert1.html>

Review Questions

1. How many significant figures are in the following numbers?
 - a. 2.3
 - b. 17.95
 - c. 9.89×10^3
 - d. 170
 - e. 22.1
 - f. 1.02
 - g. 19.84
2. Perform the following calculations and give your answer with the correct number of significant figures:
 - a. $10.5 + 11.62$
 - b. $0.01223 + 1.01$
 - c. $19.85 - 0.0113$
3. Perform the following calculations and give your answer with the correct number of significant figures:
 - a. 0.1886×12
 - b. $2.995 \div 0.16685$
 - c. $1210 \div 0.1223$
 - d. 910×0.18945

2.5 Using Algebra in Chemistry

Lesson Objectives

The student will:

- perform algebraic manipulations to solve equations.
- use the density equation to solve for the density, mass, or volume when two of the quantities in the equation are known.
- construct conversion factors from equivalent measurements.
- apply the techniques of dimensional analysis to solving problems.
- perform metric conversions using dimensional analysis.

Vocabulary

- conversion factor
- dimensional analysis

Introduction

During your studies of chemistry (and physics as well), you will note that mathematical equations are used in a number of different applications. Many of these equations have a number of different variables that you will need to work with. You should also note that these equations will often require you to use measurements with their units. Algebra skills become very important here!

Solving Algebraic Equations

Chemists use algebraic equations to express relationships between quantities. An example of such an equation is the relationship between the density, mass, and volume of a substance: $D = \frac{m}{V}$ (density is equal to mass divided by volume). Given (or making) measurements of the mass and volume of a substance, you can use this equation to determine the density. Suppose, for example, that you have measured the mass and volume of a sample of liquid mercury and found that 5.00 mL of mercury has a mass of 67.5 grams. Plugging these measurements into the density formula gives you the density of mercury.

$$D = \frac{\text{mass}}{\text{volume}} = \frac{67.5 \text{ g}}{5.00 \text{ mL}} = 13.5 \text{ g/mL}$$

You should notice both units and significant figures are carried through the mathematical operations.

Frequently, you may be asked to use the density equation to solve for a variable other than density. For example, you may be given measurements for density and mass and be asked to determine the volume.

Example:

The density of solid lead is 11.34 g/mL. What volume will 81.0 g of lead occupy?

$$\text{Since } D = \frac{m}{V}, \text{ then } V = \frac{m}{D}.$$

$$V = \frac{81.0 \text{ g}}{11.34 \text{ g/mL}} = 7.14 \text{ mL}$$

A common equation used in chemistry is $PV = nRT$. Even without knowing what these variables represent, you can manipulate this equation to solve for any of the five quantities.

$$P = \frac{nRT}{V} \quad V = \frac{nRT}{P} \quad n = \frac{PV}{RT} \quad R = \frac{PV}{nT} \quad T = \frac{PV}{nR}$$

Make sure you recall these skills from algebra. If necessary, you should practice them.

Example:

Use the equation $\frac{A}{B} = \frac{C}{D}$ and the values $A = 15.1 \text{ g}$, $B = 3.000 \text{ mL}$, and $C = 326.96 \text{ grams}$ to determine the value of D .

$$D = \frac{BC}{A} = \frac{(3.000 \text{ mL})(326.96 \text{ g})}{(15.1 \text{ g})} = 65.0 \text{ mL}$$

The calculator-determined value for this arithmetic may yield 64.956954 mL but you now know not to report such a value. Since this answer only allows three significant figures, you must round the answer to 65.0 mL.

Conversion Factors

A **conversion factor** is a factor used to convert one unit of measurement into another unit. A simple conversion factor can be used to convert meters into centimeters, or a more complex one can be used to convert miles per hour into meters per second. Since most calculations require measurements to be in certain units, you will find many uses for conversion factors. What must always be remembered is that a conversion factor has to represent a fact; because the conversion factor is a fact and not a measurement, the numbers in a conversion factor are exact. This fact can either be simple or complex. For instance, you probably already know the fact that 12 eggs equal 1 dozen. A more complex fact is that the speed of light is 1.86×10^5 miles/second. Either one of these can be used as a conversion factor, depending on the type of calculation you might be working with.

Dimensional Analysis

Frequently, it is necessary to convert units measuring the same quantity from one form to another. For example, it may be necessary to convert a length measurement in meters to millimeters. This process is quite simple if you follow a standard procedure called dimensional analysis (also known as unit analysis or the factor-label method).

Dimensional analysis is a technique that involves the study of the dimensions (units) of physical quantities. It is a convenient way to check mathematical equations. Dimensional analysis involves considering the units you presently have and the units you wish to end up with, as well as designing conversion factors that will cancel units you don't want and produce units you do want. The conversion factors are created from the equivalency relationships between the units. For example, one unit of work is a newton meter (abbreviated $\text{N} \cdot \text{m}$). If you have measurements in newtons (a unit for force, F) and meters (a unit for distance, d), how would you calculate work? An analysis of the units will tell you that you should multiply force times distance to get work: $W = F \times d$.

Suppose you want to convert 0.0856 meters into millimeters. In this case, you need only one conversion factor that will cancel the meters unit and create the millimeters unit. The conversion factor will be created from the relationship $1000 \text{ m} = 1 \text{ mm}$.

$$(0.0856 \text{ m}) \cdot \left(\frac{1000 \text{ mm}}{1 \text{ m}}\right) = (0.0856 \cancel{\text{m}}) \cdot \left(\frac{1000 \text{ mm}}{1 \cancel{\text{m}}}\right) = 85.6 \text{ mm}$$

In the above expression, the meter units will cancel and only the millimeter unit will remain.

Example:

Convert 1.53 g to cg.

The equivalency relationship is $1.00 \text{ g} = 100 \text{ cg}$, so the conversion factor is constructed from this equivalency in order to cancel grams and produce centigrams.

$$(1.53 \text{ g}) \cdot \left(\frac{100 \text{ cg}}{1 \text{ g}}\right) = 153 \text{ cg}$$

Example:

Convert 1000. in. to ft.

The equivalency between inches and feet is $12 \text{ in.} = 1 \text{ ft.}$ The conversion factor is designed to cancel inches and produce feet.

$$(1000. \text{ in.}) \cdot \left(\frac{1 \text{ ft.}}{12 \text{ in.}}\right) = 83.33 \text{ ft}$$

Each conversion factor is designed specifically for the problem. In the case of the conversion above, we need to cancel inches, so we know that the inches component in the conversion factor needs to be in the denominator.

Example:

Convert 425 klums to piks given the equivalency relationship $10 \text{ klums} = 1 \text{ pik.}$

$$(425 \text{ klums}) \cdot \left(\frac{1 \text{ pik}}{10 \text{ klums}}\right) = 42.5 \text{ piks}$$

Sometimes, it is necessary to insert a series of conversion factors. Suppose we need to convert miles to kilometers, and the only equivalencies we know are $1 \text{ mi} = 5,280 \text{ ft}$, $12 \text{ in.} = 1 \text{ ft}$, $2.54 \text{ cm} = 1 \text{ in.}$, $100 \text{ cm} = 1 \text{ m}$, and $1000 \text{ m} = 1 \text{ km}$. We will set up a series of conversion factors so that each conversion factor produces the next unit in the sequence.

Example:

Convert 12 mi to km.

$$(12 \text{ mi}) \cdot \left(\frac{5280 \text{ ft}}{1 \text{ mi}}\right) \cdot \left(\frac{12 \text{ in.}}{1 \text{ ft.}}\right) \cdot \left(\frac{2.54 \text{ cm}}{1 \text{ in.}}\right) \cdot \left(\frac{1 \text{ m}}{100 \text{ cm}}\right) \cdot \left(\frac{1 \text{ km}}{1000 \text{ m}}\right) = 19 \text{ km}$$

In each step, the previous unit is canceled and the next unit in the sequence is produced.

Conversion factors for area and volume can also be produced by this method.

Example:

Convert 1500 cm^2 to m^2 .

$$(1500 \text{ cm}^2) \cdot \left(\frac{1 \text{ m}}{100 \text{ cm}}\right)^2 = (1500 \text{ cm}^2) \cdot \left(\frac{1 \text{ m}^2}{10,000 \text{ cm}^2}\right) = 0.15 \text{ m}^2$$

Example:

Convert 12.0 in^3 to cm^3 .

$$(12.0 \text{ in}^3) \cdot \left(\frac{2.54 \text{ cm}}{1 \text{ in}}\right)^3 = (12.0 \text{ in}^3) \cdot \left(\frac{16.4 \text{ cm}^3}{1 \text{ in}^3}\right) = 197 \text{ cm}^3$$

Lesson Summary

- Conversion factors are used to convert one unit of measurement into another unit.
- Dimensional analysis involves considering both the units you presently have and the units you wish to end up with, as well as designing conversion factors that will cancel units you don't want and produce units you do want.

Further Reading / Supplemental Links

Visit this website for a video series that reviews topics on measurement.

- <http://www.learner.org/resources/series184.html>

This website provides a math skills review on dimensional analysis.

- <http://www.chem.tamu.edu/class/fyp/mathrev/mr-da.html>

Review Questions

1. For the equation $PV = nRT$, re-write it so that it is in the form of $T =$.
2. The equation for density is $D = \frac{m}{V}$. If D is 12.8 g/cm^3 and m is 46.1 g , solve for V , keeping significant figures in mind.
3. The equation $P_1 \cdot V_1 = P_2 \cdot V_2$, known as Boyle's law, shows that gas pressure is inversely proportional to its volume. Re-write Boyle's law so it is in the form of $V_1 =$.
4. The density of a certain solid is measured and found to be 12.68 g/mL . Convert this measurement into kg/L .
5. In a nuclear chemistry experiment, an alpha particle is found to have a velocity of $14,285 \text{ m/s}$. Convert this measurement into miles/hour (mi/h).

2.6 Scientific Notation

Lesson Objectives

The student will:

- use scientific notation to express large and small numbers.
- add, subtract, multiply, and divide using scientific notation.

Vocabulary

- scientific notation

Introduction

Work in science frequently involves very large and very small numbers. The speed of light, for example, is 300,000,000 m/s; the mass of the earth is 6,000,000,000,000,000,000,000 kg; and the mass of an electron is 0.000000000000000000000000000009 kg. It is very inconvenient to write out such numbers and even more inconvenient to attempt to carry out mathematical operations with them. Scientists and mathematicians have designed an easier method to deal with such long numbers. This more convenient system is called exponential notation by mathematicians and scientific notation by scientists.

What is Scientific Notation?

In **scientific notation**, very large and very small numbers are expressed as the product of a number between 1 and 10 multiplied by some power of 10. For example, the number 9,000,000 can be written as the product of 9 times 1,000,000. In turn, 1,000,000 can be written as 10^6 . Therefore, 9,000,000 can be written as 9×10^6 . In a similar manner, 0.00000004 can be written as 4 times $\frac{1}{10^8}$, or 4×10^{-8} .

This is called the "coefficient." → 6.5×10^4 ← This is called the "exponent."

TABLE 2.7: Examples of Scientific Notation

Decimal Notation
95,672

Scientific Notation
 9.5672×10^4

TABLE 2.7: (continued)

Decimal Notation	Scientific Notation
8,340	8.34×10^3
100	1×10^2
7.21	7.21×10^0
0.014	1.4×10^{-2}
0.0000000080	8.0×10^{-9}
0.00000000000975	9.75×10^{-12}

As you can see from the examples in **Table 2.7**, to convert a number from decimal form into scientific notation, you count the number of spaces needed to move the decimal, and that number becomes the exponent of 10. If you are moving the decimal to the left, the exponent is positive, and if you are moving the decimal to the right, the exponent is negative. You should note that *all significant figures are maintained in scientific notation*. You will probably realize that the greatest advantage of using scientific notation occurs when there are many non-significant figures.

Scientific Notation in Calculations

Addition and Subtraction

When numbers in exponential form are added or subtracted, the exponents must be the same. If the exponents are the same, the coefficients are added and the exponent remains the same.

Example:

$$(4.3 \times 10^4) + (1.5 \times 10^4) = (4.3 + 1.5) \times 10^4 = 5.8 \times 10^4$$

Note that the example above is the same as:

$$43,000 + 15,000 = 58,000 = 5.8 \times 10^4.$$

Example:

$$(8.6 \times 10^7) - (5.3 \times 10^7) = (8.6 - 5.3) \times 10^7 = 3.3 \times 10^7$$

Example:

$$(8.6 \times 10^5) + (3.0 \times 10^4) = ?$$

These two exponential numbers do not have the same exponent. If the exponents of the numbers to be added or subtracted are not the same, then one of the numbers must be changed so that the two numbers have the same exponent. In order to add them, we can change the number 3.0×10^4 to 0.30×10^5 . This change is made by moving the decimal one place to the left and increasing the exponent by one. Now the two numbers can be added.

$$(8.6 \times 10^5) + (0.30 \times 10^5) = (8.6 + 0.30) \times 10^5 = 8.9 \times 10^5$$

We could also have chosen to alter the other number. Instead of changing the second number to a higher exponent, we could have changed the first number to a lower exponent.

$$8.6 \times 10^5 \text{ becomes } 86 \times 10^4$$

$$(86 \times 10^4) + (3.0 \times 10^4) = (86 + 3.0) \times 10^4 = 89 \times 10^4$$

Even though it is not always necessary, the preferred practice is to express exponential numbers in proper form, which has only one digit to the left of the decimal. When 89×10^4 is converted to proper form, it becomes 8.9×10^5 , which is precisely the same result as before.

Multiplication and Division

When multiplying or dividing numbers in exponential form, the numbers do not have to have the same exponents. To multiply exponential numbers, multiply the coefficients and add the exponents. To divide exponential numbers, divide the coefficients and subtract the exponents.

Multiplication Examples:

$$(4.2 \times 10^4) \cdot (2.2 \times 10^2) = (4.2 \cdot 2.2) \times 10^{4+2} = 9.2 \times 10^6$$

The product of 4.2 and 2.2 is 9.24, but since we are limited to two significant figures, the coefficient is rounded to 9.2.

$$(2 \times 10^9) \cdot (4 \times 10^{14}) = (2 \cdot 4) \times 10^{9+14} = 8 \times 10^{23}$$

$$(2 \times 10^{-9}) \cdot (4 \times 10^4) = (2 \cdot 4) \times 10^{-9+4} = 8 \times 10^{-5}$$

$$(2 \times 10^{-5}) \cdot (4 \times 10^{-4}) = (2 \cdot 4) \times 10^{(-5)+(-4)} = 8 \times 10^{-9}$$

$$(8.2 \times 10^{-9}) \cdot (8.2 \times 10^{-4}) = (8.2 \cdot 8.2) \times 10^{(-9)+(-4)} = 67.24 \times 10^{-13}$$

In this last example, the product has too many significant figures and is not in proper exponential form. We must round to two significant figures and adjust the decimal and exponent. The correct answer would be 6.7×10^{-12} .

Division Examples:

$$\frac{8 \times 10^7}{2 \times 10^4} = 4 \times 10^{7-4} = 4 \times 10^3$$

$$\frac{8 \times 10^{-7}}{2 \times 10^{-4}} = 4 \times 10^{(-7)-(-4)} = 4 \times 10^{-3}$$

$$\frac{4.6 \times 10^3}{2.3 \times 10^{-4}} = 2.0 \times 10^{(3)-(-4)} = 2.0 \times 10^7$$

In the example above, since the original coefficients have two significant figures, the answer must also have two significant figures. Therefore, the zero in the tenths place is written to indicate the answer has two significant figures.

Lesson Summary

- Very large and very small numbers in science are expressed in scientific notation.
- All significant figures are maintained in scientific notation.
- When numbers in exponential form are added or subtracted, the exponents must be the same. If the exponents are the same, the coefficients are added and the exponent remains the same.
- To multiply exponential numbers, multiply the coefficients and add the exponents.
- To divide exponential numbers, divide the coefficients and subtract the exponents.

Review Questions

1. Write the following numbers in scientific notation.

- a. 0.0000479
- b. 251,000,000
- c. 4,260
- d. 0.00206

Do the following calculations without a calculator.

- 2. $(2.0 \times 10^3) \cdot (3.0 \times 10^4)$
- 3. $(5.0 \times 10^{-5}) \cdot (5.0 \times 10^8)$
- 4. $(6.0 \times 10^{-1}) \cdot (7.0 \times 10^{-4})$
- 5. $\frac{(3.0 \times 10^{-4}) \cdot (2.0 \times 10^{-4})}{2.0 \times 10^{-6}}$

Do the following calculations.

- 6. $(6.0 \times 10^7) \cdot (2.5 \times 10^4)$
- 7. $\frac{4.2 \times 10^{-4}}{3.0 \times 10^{-2}}$

2.7 Evaluating Measurements

Lesson Objectives

The student will:

- define accuracy and precision.
- explain the difference between accuracy and precision.
- indicate whether a given data set is precise, accurate, both, or neither.
- calculate percent error in an experiment.

Vocabulary

- accuracy
- percent error
- precision

Introduction

Accuracy and precision are two words that we hear a lot in science, math, and other everyday events. They are also, surprisingly, two words that are often misused. For example, you may hear car advertisements talking about the car's ability to handle precision driving. But what do these two words mean?

Accuracy and Precision

Every measurement compares the physical quantity being measured with a fixed standard of measurement, such as the centimeter or the gram. In describing the reliability of a measurement, scientists often use the terms accuracy and precision. **Accuracy** refers to how close a measurement is to the true value of the quantity being measured. **Precision** refers to how close the values in a set of measurements are to one another. If you are using a flawed measuring instrument, you could get very precise measurements (meaning they are very reproducible), but the measurements would be inaccurate. In many cases, the true value of the measurement is not known, and we must take our measurement as the true value. In such cases, instruments are checked carefully to verify that they are unflawed before a series of precise measurements are made. It is assumed that good instruments and precise measurements imply accuracy.

Suppose a student made the same volume measurement four times and obtained the following measurements: 34.25 mL, 34.45 mL, 34.33 mL, and 34.20 mL. The average of these four readings is 34.31 mL. If the actual volume was known to be 34.30 mL, what could we say about the accuracy and precision of these measurements, and how much confidence would we have in the answer? Since the final average is very close to the actual value, we would say that

the answer is accurate. However, the individual readings are not close to each other, so we would conclude that the measurements were not precise. If we did not know the correct answer, we would have very little confidence that these measurements produced an accurate value.

Consider the values obtained by another student making the same measurements: 35.27 mL, 35.26 mL, 35.27 mL, and 35.28 mL. In this case, the average measurement is 35.27 mL, and the set of measurements is quite precise since all readings are within 0.1 mL of the average measurement. We would normally have confidence in this measurement since the precision is so good, but if the actual volume is 34.30 mL, the measurements are not accurate. Generally, situations where the measurements are precise but not accurate are caused by a flawed measuring instrument. The ideal situation is to have quality measuring instruments so that precision will imply accuracy.

Percent Error

Percent error is a common way of evaluating the accuracy of a measured value. Anytime an experiment is conducted, a certain degree of uncertainty and error is expected. Scientists often express this uncertainty and error in measurement by reporting a percent error.

$$\text{percent error} = \frac{(\text{accepted value} - \text{experimental value})}{(\text{accepted value})} \times 100\%$$

The experimental value is what you recorded or calculated based on your own experiment in the lab. The value that can be found in reference tables is called the accepted value. Percent error is a measure of how far the experimental value is from the accepted value.

Example:

A student determined the density of a sample of silver to be 10.3 g/cm^3 . The density of silver is actually 10.5 g/cm^3 . What is the percent error in the experimentally determined density of silver?

$$\text{percent error} = \frac{10.5 \text{ g/cm}^3 - 10.3 \text{ g/cm}^3}{10.5 \text{ g/cm}^3} \times 100\% = 1.90\%$$

Lesson Summary

- Accuracy reflects how close the measured value is to the actual value.
- Precision reflects how close the values in a set of measurements are to each other.
- Accuracy is affected by the quality of the instrument or measurement.
- Percent error is a common way of evaluating the accuracy of a measured value.
- $\text{percent error} = \frac{(\text{accepted value} - \text{experimental value})}{(\text{accepted value})} \times 100\%$

Further Reading / Supplemental Links

The *learner.org* website allows users to view streaming videos of the Annenberg series of chemistry videos. You are required to register before you can watch the videos, but there is no charge to register. The website has a video that apply to this lesson called “Measurement: The Foundation of Chemistry” that details the value of accuracy and precision.

- <http://learner.org/resources/series61.html>

Review Questions

1. Suppose you want to hit the center of this circle with a paint ball gun. Which of the following are considered accurate? Precise? Both? Neither?

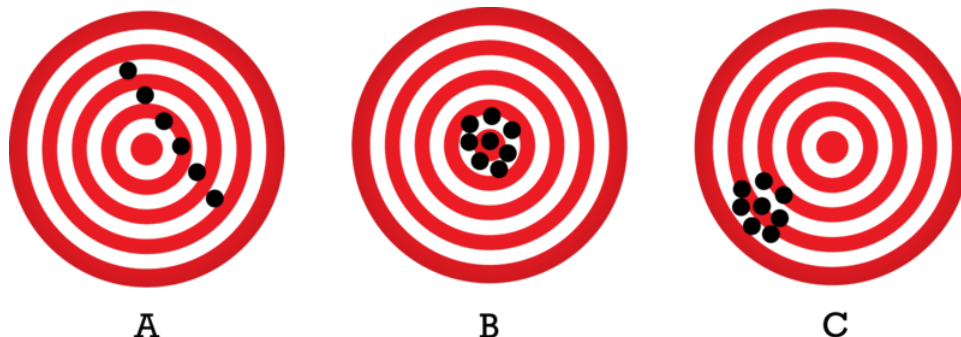

2. Four students take measurements to determine the volume of a cube. Their results are 15.32 cm^3 , 15.33 cm^3 , 15.33 cm^3 , and 15.31 cm^3 . The actual volume of the cube is 16.12 cm^3 . What statement(s) can you make about the accuracy and precision in their measurements?
3. Distinguish between accuracy and precision.
4. Nisi was asked the following question on her lab exam: When doing an experiment, what term best describes the reproducibility in your results? What should she answer?
- accuracy
 - care
 - precision
 - significance
 - uncertainty
5. Karen was working in the lab doing reactions involving mass. She needed to weigh out 1.50 g of each reactant and put them together in her flask. She recorded her data in her data table (Table 2.8). What can you conclude by looking at Karen's data?
- The data is accurate but not precise.
 - The data is precise but not accurate.
 - The data is neither precise nor accurate.
 - The data is precise and accurate.
 - You really need to see the balance Karen used.

TABLE 2.8: Data Table for Problem 5

	Mass of Reactant A	Mass of Reactant B
Trial 1	$1.47 \pm 0.02 \text{ g}$	$1.48 \pm 0.02 \text{ g}$
Trial 2	$1.46 \pm 0.02 \text{ g}$	$1.46 \pm 0.02 \text{ g}$
Trial 3	$1.48 \pm 0.02 \text{ g}$	$1.50 \pm 0.02 \text{ g}$

6. John uses his thermometer and finds the boiling point of ethanol to be 75°C . He looks in a reference book and finds that the actual boiling point of ethanol is 78°C . What is his percent error?
7. The density of water at 4°C is known to be 1.00 g/mL . Kim experimentally found the density of water to be 1.085 g/mL . What is her percent error?
8. An object has a mass of 35.0 g . On a digital balance, Huey finds the mass of the object to be 34.92 g . What is the percent error of his balance?

2.8 Graphing

Lesson Objectives

The student will:

- correctly graph data with the proper scale, units, and best fit curve.
- recognize patterns in data from a graph.
- solve for the slope of given line graphs.

Vocabulary

- extrapolation
- graph
- interpolation
- slope

Introduction

Scientists search for regularities and trends in data. To make it easier to find these regularities and trends, scientists often present data in either a table or a graph. The table below presents data about the pressure and volume of a sample of gas. You should note that all tables have a title and include the units of the measurements. The unit of pressure used here is atm (atmosphere).

Data Table A: Pressure vs. Volume Data for a Gas Sample

Pressure (in atm)	Volume (in liters)
0.50	10.0
1.00	5.00
1.50	3.33
2.00	2.50
2.50	2.00
3.00	1.67

You may note a regularity that appears in this table: as the pressure of the gas increases, its volume decreases. This regularity or trend becomes even more apparent in a graph of this data. A **graph** is a pictorial representation of the relationship between variables on a coordinate system.

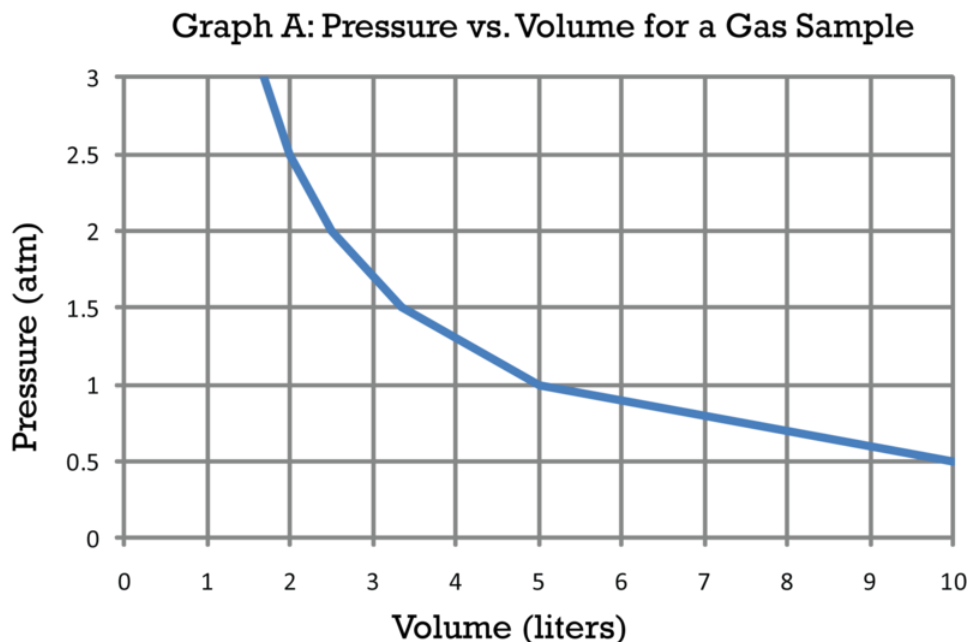

When the data from Data Table A is plotted as a graph, the trend in the relationship between the pressure and volume of a gas sample becomes more apparent. The graph aids the scientist in the search for any regularity that may exist in the data.

Drawing Line Graphs

Reading information from a line graph is easier and more accurate as the size of the graph increases. In the example below, the graph on the left uses only a small fraction of the space available on the graph paper. The graph on the right shows the same data but uses all the space available. If you were attempting to determine the pressure at a temperature of 110 K, using the graph on the left would give a less accurate result than using the graph on the right.

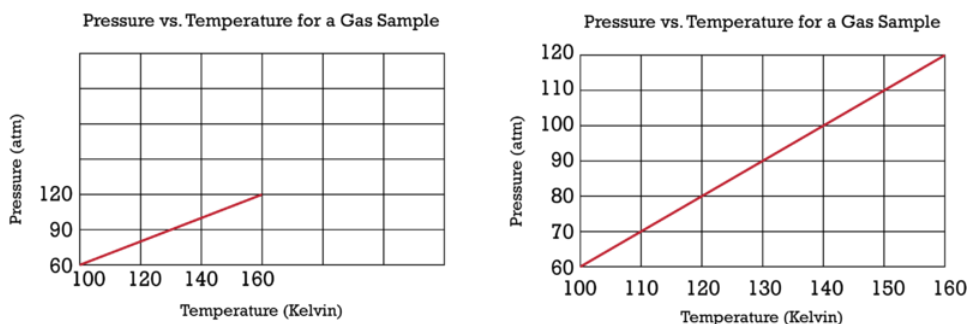

When you draw a line graph, you should arrange the numbers on the axes to use as much of the graph paper as you can. If the lowest temperature in your data is 100 K and the highest temperature in your data is 160 K, you should arrange for 100 K to be on the extreme left of your graph and 160 K to be on the extreme right of your graph. The creator of the graph on the left did not take this advice and did not produce a very good graph. You should also make sure that the axes on your graph are labeled and that your graph has a title.

Reading Information from a Graph

When we draw a line graph from a set of data points, we are inferring a trend and constructing new data points between known data points. This process is called **interpolation**. Even though we may only have a few data points, we are estimating the values between measured points, assuming that the line connecting these data points is a good model of what we're studying.

Consider the following set of data for the solubility of KClO_3 in water. Data Table B shows that there are exactly six measured data points. When the data is graphed, however, the graph maker assumes that the relationship between the temperature and the solubility exists for all points within the data range. The graph maker draws a line by interpolating the data points between the actual data points. Note that the line is not drawn by just connecting the data points in a connect-the-dot manner. Instead, the line is a smooth curve that reasonably connects the known data points.

Data Table B: Solubility of Potassium Chlorate

Temperature ($^{\circ}\text{C}$)	Solubility (g/100 mL H_2O)
0	3.3
20	7.3
40	13.9
60	23.8
80	37.5
100	56.3

We can now read Graph B1, shown below, for points that were not actually measured. If we wish to determine the solubility of KClO_3 at 70°C , we follow the vertical grid line for 70°C up to where it touches the graphed line and then follow the horizontal grid line to the axis to read the solubility. In this case, we would read the solubility to be $30.0\text{ g}/100\text{ mL}$ of H_2O at 70°C .

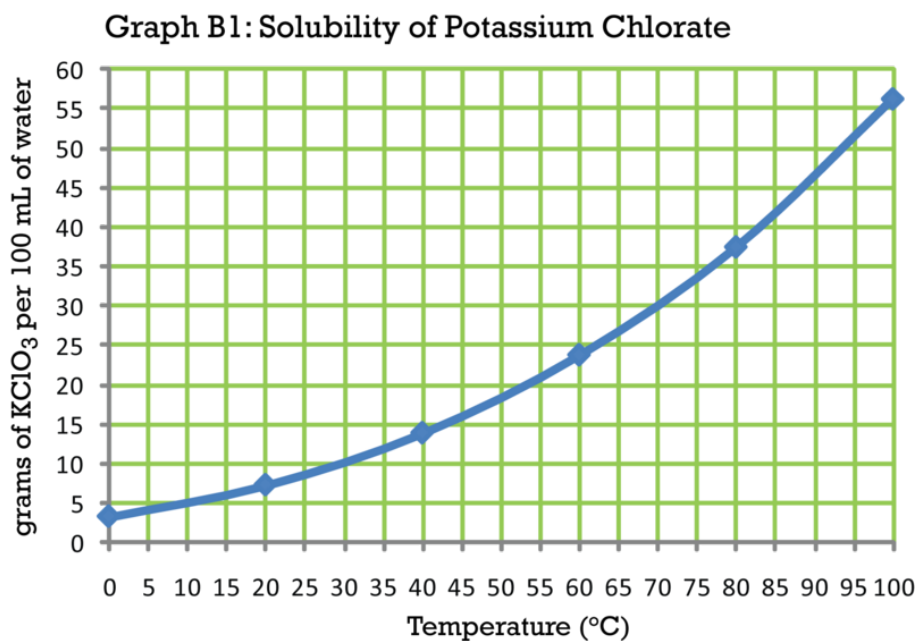

There are also occasions when scientists wish to know more about points that are outside the range of measured data points. Extending the line graph beyond the ends of the original line, using the basic shape of the curve as a guide, is called **extrapolation**.

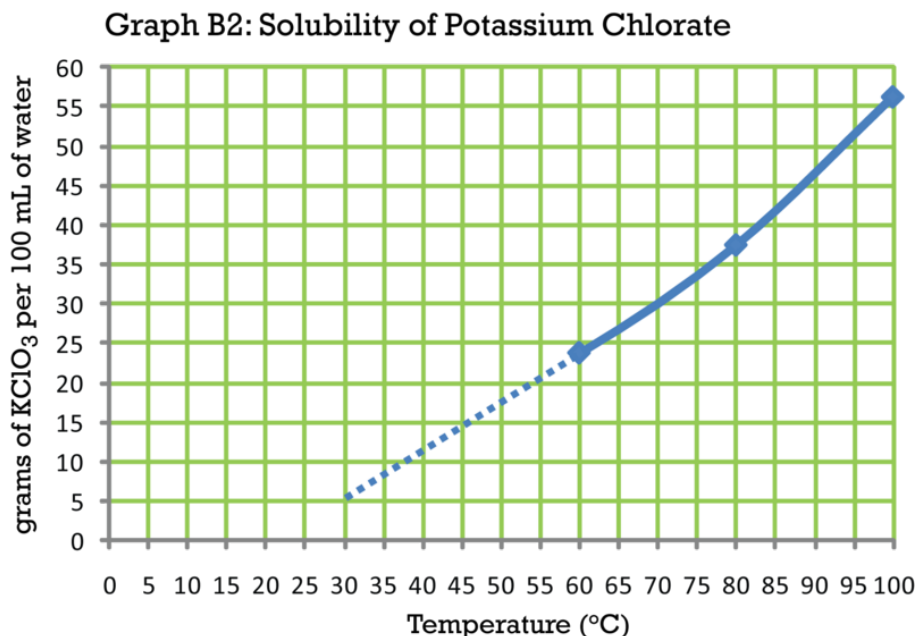

Suppose the graph for the solubility of potassium chlorate has been made from just three measured data points. If the actual data points for the curve were the solubility at 60°C, 80°C, and 100°C, the graph would be the solid line shown in Graph B2 above. If the solubility at 30°C was desired, we could extrapolate the curve (the dotted line) and obtain a solubility of 5.0 g/100 mL of H₂O. If we check the more complete graph above (Graph B1), you can see that the solubility at 30°C is closer to 10. g/100 mL of H₂O. The reason the second graph produces such a different answer is because the real behavior of potassium chlorate in water is more complicated than the behavior suggested by the extrapolated line. For this reason, extrapolation is only acceptable for graphs where there is evidence that the relationship shown in the graph will hold true beyond the ends of the graph. Extrapolation is more dangerous than interpolation in terms of producing possibly incorrect data.

In situations where it is unreasonable to interpolate or extrapolate data points from the actual measured data points, a line graph should not be used. If it is desirable to present data in a graphic form but a line graph is not useful, a bar graph can often be used instead. Consider the data in the following table.

Data Table C: Trout Creek Rainfall 1980-1989

Year	Rainfall (in inches)
1980	24.7
1981	21.2
1982	14.5
1983	13.2
1984	12.1
1985	16.8
1986	19.9
1987	29.2
1988	31.6
1989	21.0

For this set of data, you would not plot the data on a line graph because interpolating between years does not make sense; the concept of the average yearly rainfall halfway between the years 1980 and 1981 would not make sense. Looking at the general trend exhibited by Data Table C also does not provide the slightest amount of evidence about the rainfall in 1979 or 1990. Therefore, the interpolation and extrapolation of the data in this table is not reasonable. If we wish to present this information in a graphic form, a bar graph like the one seen in Graph C would be best.

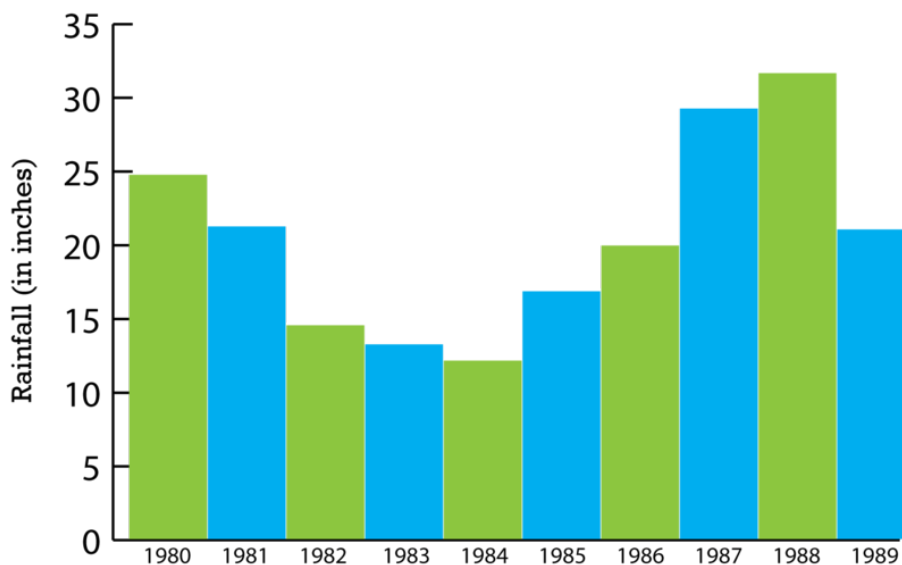
Graph C: Trout Creek Rainfall 1980-1989

From this bar graph, you could very quickly answer questions like, “Which year was most likely a drought year for Trout Creek?” and “Which year was Trout Creek most likely to have suffered from a flood?”

Finding the Slope of a Graph

As you may recall from algebra, the slope of the line may be determined from the graph. The slope represents the rate at which one variable is changing with respect to the other variable. For a straight-line graph, the slope is constant for the entire line, but for a non-linear graph, the slope varies at different points along the line. For a straight-line graph, the slope for all points along the line can be determined from any section of the graph. Consider the following data table and the linear graph that follows.

Data Table D: Temperature vs. Volume Data for a Gas Sample

Temperature (°C)	Volume of Gas (mL)
20	60
40	65
60	70
80	75
100	80
120	85

Graph D: Temperature vs. Volume for a Gas Sample

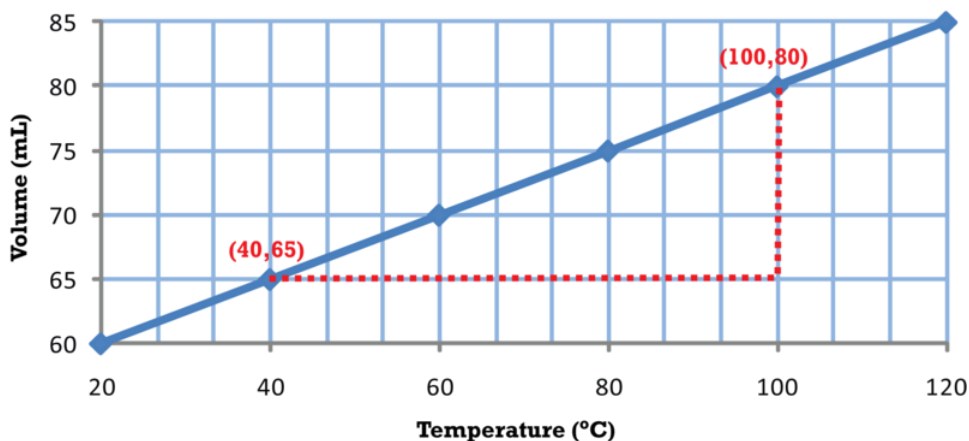

The relationship in this set of data is linear; in other words, the data produces a straight-line graph. The slope of this line is constant at all points on the line. The **slope** of a line is defined as the rise (change in vertical position) divided by the run (change in horizontal position). For a pair of data points, the coordinates of the points are identified as (x_1, y_1) and (x_2, y_2) . In this case, the data points selected are $(40^\circ\text{C}, 65\text{ mL})$ and $(100^\circ\text{C}, 80\text{ mL})$. The slope can then be calculated in the following manner:

$$\text{slope } m = \frac{\text{rise}}{\text{run}} = \frac{(y_2 - y_1)}{(x_2 - x_1)} = \frac{(80\text{ mL} - 65\text{ mL})}{(100^\circ\text{C} - 40^\circ\text{C})} = 0.25\text{ mL}/^\circ\text{C}$$

Therefore, the slope of the line is $0.25\text{ mL}/^\circ\text{C}$. The fact that the slope is positive indicates that the line is rising as it moves from left to right and that the volume increases by 0.25 mL for each 1°C increase in temperature. A negative slope would indicate that the line was falling as it moves from left to right.

For a non-linear graph, the slope must be calculated for each point independently. Since the line will be a curve, the slope is calculated from the tangent to the curve at the point in question. Data Table E and Graph E are for a

reaction in which the concentration of one of the reactants, bromine, was measured against time. The concentration is expressed in moles/liter, which is symbolized by M.

Data Table E: Concentration of Bromine vs. Time

Time (seconds)	Concentration of Br ₂ (M)
1.0	0.063
2.0	0.045
3.0	0.037
4.0	0.032
5.0	0.028
6.0	0.026
7.0	0.024

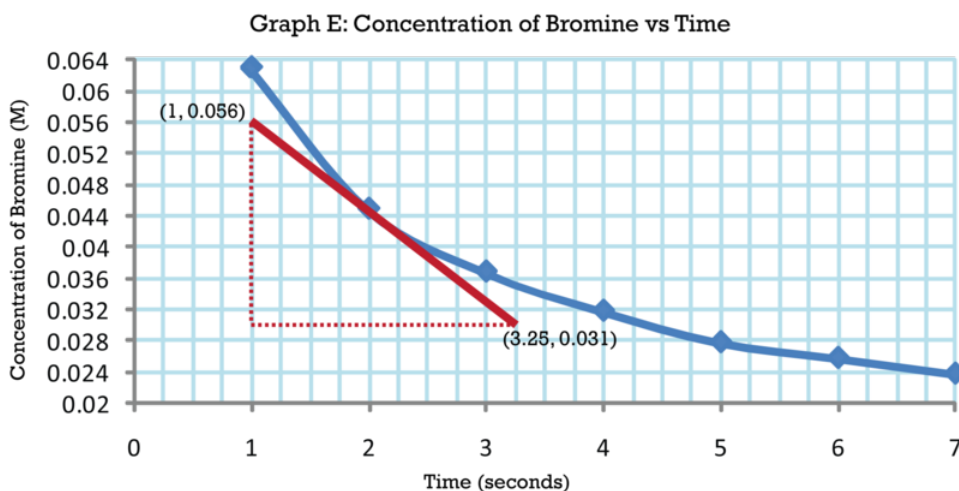

In order to determine the slope at some point on a curved line, a tangent (approximate) is drawn in as a line that just touches the point in question. Once the tangent has been drawn, the slope of the tangent is determined, which is also the slope of the curve at that point. In the graph above, the tangent has been drawn at the point where $t = 2$ seconds. We determine the x - and y -coordinates for two points along the tangent line (as best we can) and use the coordinates of those two points to calculate the slope of the tangent. The coordinates of the point at the left end of the tangent line is determined to be (1.00 s, 0.056 M). The coordinates of the point at the right end of the line is harder to determine, and we are guessing that the coordinates are (3.25 s, 0.031 M).

$$\text{slope } m = \frac{\text{rise}}{\text{run}} = \frac{(y_2 - y_1)}{(x_2 - x_1)} = \frac{(0.031 \text{ M} - 0.056 \text{ M})}{(3.25 \text{ s} - 1.00 \text{ s})} = -0.011 \text{ M/s}$$

Since the slope is a negative number, we know the line is decreasing in height. At $t = 2$ seconds, the concentration of bromine is decreasing at a rate of 0.011 moles/liter per second. At other points along this curve, the slope would be different. From the appearance of the curve, it is apparent that the slope is negative (the concentration of bromine is decreasing) all along the line, but it appears to be decreasing more quickly at the beginning of the reaction and less quickly as time increases.

Lesson Summary

- Tables and graphs are two common methods of presenting data that aid in the search for regularities and trends within the data.
- When we draw a line graph from a set of data points, we are inferring a trend and constructing new data points between known data points. This process is called interpolation.
- Constructing data points beyond the end of a line graph, using the basic shape of the curve as a guide, is called extrapolation.
- The slope of a graph represents the rate at which one variable is changing with respect to the other variable.
- For a straight-line graph, the slope for all points along the line can be determined from any section of the graph.
- For a non-linear graph, the slope must be determined for each point by drawing a tangent line to the curve at the point in question.

Review Questions

1. What would you do to find the slope of a curved line?
2. Andrew was completing his density lab for his chemistry lab exam. He collected the following data in his data table (shown in **Table 2.9**).
 - a. Draw a graph to represent the data.
 - b. Calculate the slope.
 - c. What does the slope of the line represent?

TABLE 2.9: Data Table for Problem 2

Mass of Solid (g)	Volume of Solution (mL)
3.4	0.3
6.8	0.6
10.2	0.9
21.55	1.9
32.89	2.9
44.23	3.9
55.57	4.9

3. Donna is completing the last step in her experiment to find the effect of the concentration of ammonia on the reaction. She has collected the following data from her time trials and is ready for the analysis. Her data table is **Table 2.10**. Help Donna by graphing the data, describing the relationship, finding the slope, and then discussing the meaning of the slope.

TABLE 2.10: Data Table for Problem 3

Time (s)	Concentration (mol/L)
0.20	49.92
0.40	39.80
0.60	29.67
0.81	20.43
1.08	14.39

TABLE 2.10: (continued)

Time (s)	Concentration (mol/L)
1.30	10.84
1.53	5.86
2.00	1.95
2.21	1.07
2.40	0.71
2.60	0.71

All images, unless otherwise stated, are created by CK-12 Foundation and are under the Creative Commons license CC-BY-NC-SA.

2.9 References

1. Original photograph by Mr. Bo Bengtsen, Danish National Metrology Institute. Edited version by Greg L. [Denmark's standard kilogram](#). GNU Free Documentation
2. Airar. [Standard Meter in the 18th century](#). GNU Free Documentation

CHAPTER **3**

Matter and Energy

Chapter Outline

- 3.1** **WHAT IS MATTER?**
 - 3.2** **PROPERTIES AND CHANGES OF MATTER**
 - 3.3** **ENERGY**
 - 3.4** **REFERENCES**
-

3.1 What is Matter?

Lesson Objectives

The student will:

- define matter and explain how it is composed of building blocks known as atoms.
- explain the differences between substances and mixtures.
- classify mixtures as homogeneous or heterogeneous.
- identify the chemical symbols of common elements.
- explain the difference between an element and a compound by their symbols or formulas.
- demonstrate the proper use of parentheses and subscripts in writing chemical formulas.
- determine the number of atoms and name of each element in a compound.

Vocabulary

- atom
- compound
- element
- heterogeneous mixture
- homogeneous mixture
- law of constant composition
- matter
- molecule

Introduction

Matter is anything that has mass and volume. The entire universe is composed of matter, which is in turn composed of atoms. An **atom** is the basic building block of all matter. All matter in the universe, from a teaspoon of salt to the Pacific Ocean, has mass and occupies space. The salt and ocean, however, have very different properties and behaviors. Since everything in the universe is composed of matter, there are clearly many types of matter. In this lesson, you will learn about how scientists classify the different types of matter.

Categories of Matter

Matter can be classified into two broad categories: mixtures and pure substances, as illustrated below.

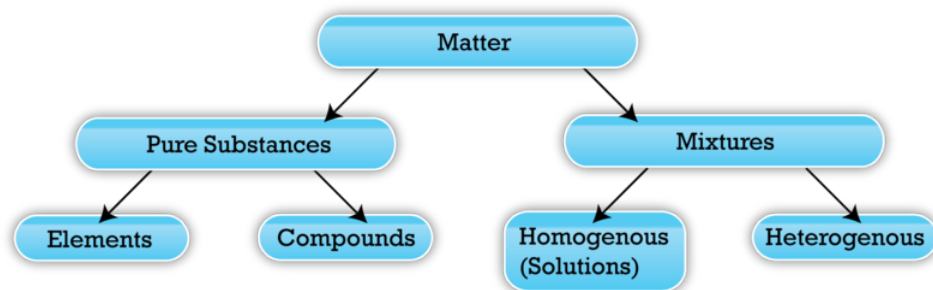

Mixtures are physical combinations of two or more substances. The term “physical combination” refers to mixing together different substances that do not chemically react with each other. The physical appearance of the substances may change, but the atoms in the substances do not.

In comparison, a pure substance is a form of matter that has a constant composition and constant properties throughout the sample. Elements and compounds are both example of pure substances.

Mixtures: Homogeneous and Heterogeneous

One example of a mixture is sand and gravel stirred together. In this case, you can see that there are two different substances present, each with the same properties that it had before it was mixed. When substances do not mix thoroughly and evenly (like sand and gravel), the mixture is said to be heterogeneous. A **heterogeneous mixture** consists of visibly different substances.

Another example of a mixture is salt dissolved in water. In this case, you cannot see the different substances, but you can test the solution to show that each substance (salt and water) has the same chemical properties it had before being mixed. When substances mix thoroughly and evenly (like salt in water), the mixture is said to be homogeneous. **Homogeneous mixtures** are often referred to as solutions. Solutions often may appear to be one pure substance, but some simple tests can show that the solutions are indeed mixtures.

Pure Substances: Elements and Compounds

Elements are the simplest substances. An **element** is a substance that is made up of only one type of atom. It doesn't matter if the atoms are in groups, as in P_4 or S_8 , or isolated, as in Na. As long as there is only one kind of atom, the substance is an element. Elements cannot be chemically broken down into anything smaller and still retain the properties of the element. For example, an atom of iron can be smashed into electrons, protons, and neutrons, but those pieces would not have the properties of iron.

Atoms from two or more elements can chemically combine to form a new substance. **Compounds** are substances that are made up of more than one type of atom. In other words, compounds are chemical combinations of elements. These combinations form new substances with completely different properties than the atoms from which they were formed.

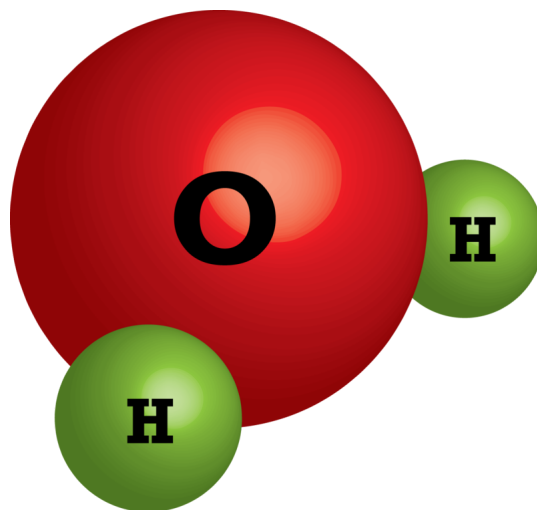

The image above is a model of water. Water is a compound consisting of one atom of oxygen and two atoms of hydrogen. Hydrogen is an explosive gas, and oxygen is a gaseous substance that supports combustion. Yet, when these two elements are chemically combined to form water, the product neither burns nor supports combustion. In fact, water is used to put out fires.

A **molecule** is the smallest particle of a compound. If you break up the molecule, you no longer have the properties of the compound. Molecules, like atoms, are too small to be seen. Even with the most powerful microscopes, we have only seen the very largest of molecules.

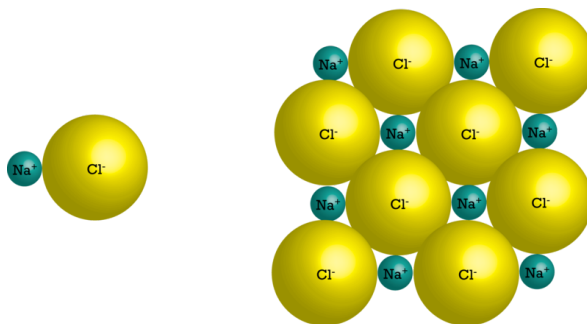

The illustration above shows a single unit of the compound called sodium chloride on the left. This single unit is made up of one sodium ion and one chloride ion. Sodium is a very reactive metal that explodes in water and burns in air, while chlorine is a very deadly, poisonous gas. When these two are combined, we get table salt (sodium chloride). When sodium chloride is in solid form, many units join together, as illustrated above on the right.

Elements: Names and Symbols

Everything, from ants to galaxies, is composed of atoms. So far, scientists have discovered or created 118 different types of atoms. Scientists have given a name to each different type of element and organized them into a chart called the periodic table. As you can see in the table below, each square contains one of the elements.

										18																																		
1A										8A																																		
1 H 1.01	2 He 4.00											13 Al 27.0	14 Si 28.1	15 P 30.1	16 S 32.1	17 Cl 35.5	18 Ar 39.9																											
3 Li 6.94	4 Be 9.01											5 B 10.8	6 C 12.0	7 N 14.0	8 O 16.0	9 F 19.0	10 Ne 20.2																											
11 Na 23.0	12 Mg 24.3	3 B 10.8	4 C 12.0	5 N 14.0	6 O 16.0	7 F 19.0	8B		11 B 10.8	12 C 12.0	13 Al 27.0	14 Si 28.1	15 P 30.1	16 S 32.1	17 Cl 35.5	18 Ar 39.9																												
19 K 39.1	20 Ca 40.1	21 Sc 45.0	22 Ti 47.9	23 V 50.9	24 Cr 52.0	25 Mn 54.9	26 Fe 55.9	27 Co 58.9	28 Ni 58.7	29 Cu 63.6	30 Zn 65.4	31 Ga 69.7	32 Ge 72.6	33 As 74.9	34 Se 79.0	35 Br 79.9	36 Kr 83.8																											
37 Rb 85.5	38 Sr 87.6	39 Y 88.9	40 Zr 91.2	41 Nb 92.9	42 Mo 95.9	43 Tc [98]	44 Ru 101	45 Rh 103	46 Pd 106	47 Ag 108	48 Cd 112	49 In 115	50 Sn 119	51 Sb 122	52 Te 128	53 I 127	54 Xe 133																											
55 Cs 133	56 Ba 137	57 La 139	72 Hf 178	73 Ta 181	74 W 184	75 Re 186	76 Os 190	77 Ir 192	78 Pt 195	79 Au 197	80 Hg 201	81 Tl 204	82 Pb 207	83 Bi 209	84 Po [209]	85 At [210]	86 Rn [222]																											
87 Fr [223]	88 Ra 226	89 Ac 227	104 Rf [261]	105 Db [262]																																								
<table border="1" style="width: 100%; border-collapse: collapse;"> <tr> <td>58 Ce 140</td> <td>59 Pr 141</td> <td>60 Nd 144</td> <td>61 Pm [145]</td> <td>62 Sm 150</td> <td>63 Eu 152</td> <td>64 Gd 157</td> <td>65 Tb 159</td> <td>66 Dy 163</td> <td>67 Ho 165</td> <td>68 Er 167</td> <td>69 Tm 169</td> <td>70 Yb 173</td> <td>71 Lu 175</td> </tr> <tr> <td>90 Th 232</td> <td>91 Pa 231</td> <td>92 U 238</td> <td>93 Np 237</td> <td>94 Pu [244]</td> <td>95 Am [243]</td> <td>96 Cm [247]</td> <td>97 Bk [247]</td> <td>98 Cf [251]</td> <td>99 Es [252]</td> <td>100 Fm [257]</td> <td>101 Md [258]</td> <td>102 No [259]</td> <td>103 Lr [260]</td> </tr> </table>																	58 Ce 140	59 Pr 141	60 Nd 144	61 Pm [145]	62 Sm 150	63 Eu 152	64 Gd 157	65 Tb 159	66 Dy 163	67 Ho 165	68 Er 167	69 Tm 169	70 Yb 173	71 Lu 175	90 Th 232	91 Pa 231	92 U 238	93 Np 237	94 Pu [244]	95 Am [243]	96 Cm [247]	97 Bk [247]	98 Cf [251]	99 Es [252]	100 Fm [257]	101 Md [258]	102 No [259]	103 Lr [260]
58 Ce 140	59 Pr 141	60 Nd 144	61 Pm [145]	62 Sm 150	63 Eu 152	64 Gd 157	65 Tb 159	66 Dy 163	67 Ho 165	68 Er 167	69 Tm 169	70 Yb 173	71 Lu 175																															
90 Th 232	91 Pa 231	92 U 238	93 Np 237	94 Pu [244]	95 Am [243]	96 Cm [247]	97 Bk [247]	98 Cf [251]	99 Es [252]	100 Fm [257]	101 Md [258]	102 No [259]	103 Lr [260]																															

Each element not only has its own name, it also has its own symbol. Scientists use abbreviations called chemical symbols to represent the elements. Many of these symbols are the first one or two letters of the modern name of the element. The first letter of a chemical symbol must always be a capital letter, and the second letter, when there is a second letter, must always be a lowercase letter. **Table 3.1** shows some examples of elements and their symbols.

TABLE 3.1: Examples of Elements

Element	Symbol
Hydrogen	H
Oxygen	O
Carbon	C
Calcium	Ca
Aluminum	Al

As seen in **Table 3.2**, the symbols for some of the elements consist of the first letter of the name and another letter (not the second letter) that comes later in the name.

TABLE 3.2: More Examples of Elements

Element	Symbol
Zinc	Zn
Magnesium	Mg
Chlorine	Cl
Arsenic	As
Zirconium	Zr

For other elements, the symbols were already used for other elements. When trying to decide on a symbol for silver, for example, the symbol S was already used for sulfur, and the symbol Si was already used for silicon. Since silver has been known to man for over a thousand years, it had a Latin name from ancient times. The old Latin name for silver was *argentum*, so it was decided that the symbol for silver would be Ag. There are a number of symbols chosen in this same manner, as seen in **Table 3.3**.

TABLE 3.3: Examples of Elements Whose Symbol Comes from Latin

Element	Ancient Name	Symbol
Silver	<i>Argentum</i>	Ag
Potassium	<i>Kalium</i>	K
Sodium	<i>Natrium</i>	Na
Gold	<i>Aurum</i>	Au
Lead	<i>Plumbum</i>	Pb
Copper	<i>Cuprum</i>	Cu
Iron	<i>Ferrum</i>	Fe

Compounds: Chemical Formulas

The chemical symbols are not only used to represent the elements, they are also used to write chemical formulas for the millions of different compounds. For a given chemical compound, the **law of constant composition** states that the ratio by mass of the elements in the compound is always the same, regardless of the source of the compound. The law of constant composition can be used to distinguish between compounds and mixtures. Compounds have a constant composition, and mixtures do not. Pure water is always 88.8% oxygen and 11.2% hydrogen by weight, regardless of the source of the water. Brass is an example of a mixture. Brass consists of two elements, copper and zinc, but it can contain as little as 10% or as much as 45% zinc.

The formula for a compound uses the symbols to indicate the type of atoms involved and uses subscripts to indicate the number of each atom in the formula. For example, aluminum combines with oxygen to form the compound aluminum oxide. Forming aluminum oxide requires two atoms of aluminum and three atoms of oxygen. Therefore, we write the formula for aluminum oxide as Al_2O_3 . The symbol Al tells us that the compound contains aluminum, and the subscript 2 tells us that there are two atoms of aluminum in each molecule. The O tells us that the compound contains oxygen, and the subscript 3 tells us that there are three atoms of oxygen in each molecule. It was decided by chemists that when the subscript for an element is 1, no subscript needs to be used. Thus the chemical formula MgCl_2 tells us that one molecule of this substance contains one atom of magnesium and two atoms of chlorine. The formula for sodium chloride is NaCl , which indicates that the compound contains one atom each of sodium and chlorine. The formula for sodium carbonate, Na_2CO_3 , indicates that there are two atoms of sodium, one atom of carbon, and three atoms of oxygen. In formulas that contain parentheses, the subscript outside of the parentheses applies to everything inside. For example, the subscript 2 in $\text{Ca}(\text{OH})_2$, the subscript 2 applies to the (OH). Therefore, this molecule of calcium hydroxide contains one atom of calcium, two atoms of oxygen, and two atoms of hydrogen.

Lesson Summary

- All matter has mass and occupies space.
- Matter can be classified into two broad categories: pure substances and mixtures.
- A pure substance is a form of matter that has constant composition and constant properties throughout the sample.
- Mixtures are physical combinations of two or more substances.
- Elements and compounds are both example of pure substances.
- Compounds are substances that are made up of more than one type of atom.

- Elements are the simplest substances made up of only one type of atom.
- The elements are organized into a chart called the periodic table.
- Scientists use abbreviations called chemical symbols to represent the elements.
- The first letter of a chemical symbol is capitalized, and the second letter is not.

Further Reading / Supplemental Links

You may listen to Tom Lehrer's humorous song "The Elements" with animation at this website.

- <http://www.privatehand.com/flash/elements.html>

This website provides a review about matter and the categories of matter.

- <http://www.thetech.org/exhibits/online/topics/50a.html>

Review Questions

1. Pure substances contain only one type of
 - a. atoms only.
 - b. molecules only.
 - c. atoms or molecules.
 - d. mixture.
2. What type of mixture produces the same properties for every sample of the mixture?
 - a. heterogeneous
 - b. homogeneous
 - c. mechanical
 - d. environmental
3. Which of the following is a heterogeneous mixture?
 - a. pure gold
 - b. distilled water
 - c. helium
 - d. milk
4. Which of the following is *not* a heterogeneous mixture?
 - a. concrete
 - b. pizza
 - c. sugar water
 - d. soup
5. If you can easily see the different parts that make up a mixture, you know that it is a _____ mixture.
 - a. homogeneous
 - b. heterogeneous
 - c. biodegradable
 - d. plasma
6. What do we call a material that is composed of two or more pure substances?
 - a. a compound

- b. an element
 - c. a mixture
 - d. a heterogeneous mixture
7. Identify the following mixtures as homogeneous or heterogeneous.
- a. brass
 - b. sugar dissolved in water
 - c. vegetable soup
8. Identify which of the following pure substances are elements and which are compounds.
- a. table salt
 - b. oxygen
 - c. water
9. A pure substance composed of two or more elements chemically combined is a
- a. homogeneous mixture.
 - b. compound.
 - c. element.
 - d. heterogeneous mixture.
10. The smallest piece of a compound that still has all the properties of the compound is a(n)
- a. atom.
 - b. formula.
 - c. mixture.
 - d. molecule.
11. Identify the elements involved in the compound H_2SO_4 .
12. How many phosphorus atoms are present in one molecule of H_3PO_4 ?

3.2 Properties and Changes of Matter

Lesson Objectives

The student will:

- explain the difference between physical and chemical properties of matter.
- list examples of physical properties.
- list examples of chemical properties.
- classify properties as chemical properties or physical properties.
- explain the difference between physical and chemical changes in matter.
- list examples of physical changes.
- list examples of chemical changes.
- classify changes as physical changes or chemical changes.

Vocabulary

- chemical change
- chemical property
- physical change
- physical property

Introduction

What kinds of properties do chemists actually measure in the laboratory? Well, you can probably guess a few. Imagine that you are having dinner at a friend's house and are served something that you don't recognize. What types of observations might you make to determine what you've been given? You might note the smell or color of the food. You might observe whether the food is a liquid or a solid. You could also pick up a small amount of food with your fork and try to figure out how much it weighs. A light dessert might be something like an angel cake, while a heavy dessert is probably a pound cake. You might also want to know something about the food's texture. Is it hard and granular like sugar cubes, or soft and easy to spread like butter?

Believe it or not, the observations you are likely to make when trying to identify an unknown food are very similar to the observations that a chemist makes when trying to learn about a new material. In general, chemists are interested in characteristics that you can test and observe, such as a chemical's smell or color, and characteristics that are far too small to see, such as what the oxygen you breathe in or the carbon dioxide you breathe out looks like. Chemists rely on color, state (solid, liquid, or gas), temperature, volume, mass, and texture. There is, however, one property you might use to learn about a food but that you should definitely not use to learn about a chemical – taste!

Physical and Chemical Properties

There are two basic types of properties that are used to identify or describe matter: physical properties and chemical properties. **Physical properties** are properties that can be observed without changing the identity of the substance. In the image below, we have water molecules that are held in liquid form on the left. Each molecule contains two atoms of hydrogen chemically bonded with one atom of oxygen. When we heat the liquid water, it changes to water vapor. The physical properties change - we can see the liquid water, but the water vapor cannot be seen. Liquid water has a higher density than water vapor, and so on. But even though the physical properties have changed, the molecules are exactly the same as before. Each water molecule still contains two hydrogen atoms and one oxygen atom chemically bonded together.

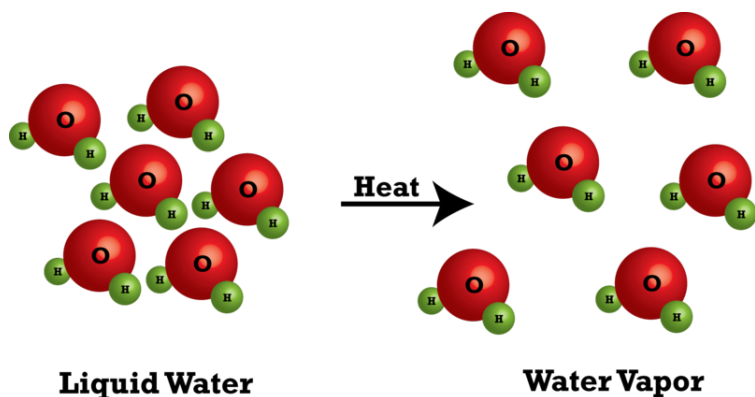

On the other hand, **chemical properties** can only be observed when a substance is changed into a new substance. In the image below, on the left we have a molecule of methane (CH_4) and two molecules of oxygen (O_2). On the right, we have two molecules of water (H_2O) and one molecule of carbon dioxide (CO_2). In this case, not only has the appearance changed, but the structures of the molecules have also changed. The new substances do not have the same chemical properties as the original ones. Therefore, this is a chemical change. The chemical properties, such as how they react and what they react with, however, will still be the same as before.

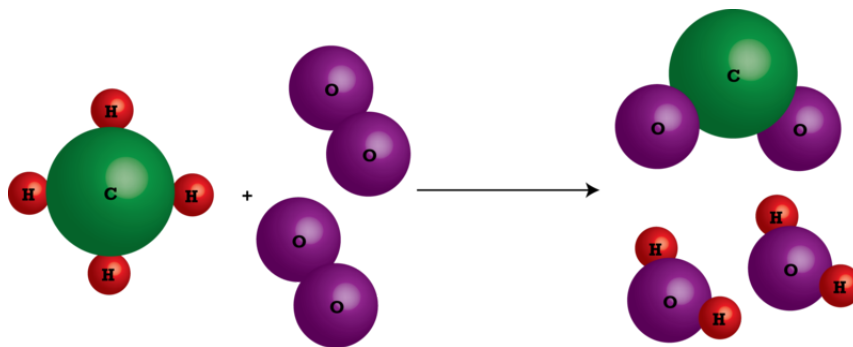

Physical and Chemical Changes

Chemists make a distinction between two different types of changes that they study: physical changes and chemical changes. **Physical changes** are changes that do not alter the identity of a substance. Some types of physical changes include:

- changes of state (changes from a solid to a liquid or a gas, and vice versa)

- separation of a mixture
- physical deformation (cutting, denting, stretching)
- making solutions (special kinds of mixtures)

If you have a jar containing a mixture of pennies and nickels and you sort the mixture so that you have one pile of pennies and another pile of nickels, you have not altered the identity of either the pennies or the nickels. You've merely separated them into two groups. Similarly, if you have a piece of paper and you rip it up, you don't change the paper into something other than a piece of paper. These are examples of a physical change. For the most part, physical changes tend to be reversible, or capable of occurring in both directions. You can turn liquid water into solid water (ice) through cooling, and you can also turn solid water into liquid water through heating (**Figure 3.1**).



FIGURE 3.1

Melting snow is an example of a physical change.

Chemical changes are changes that occur when one substance is turned into another substance. Chemical changes are frequently harder to reverse than physical changes. One good example of a chemical change is burning paper. In contrast to the act of ripping paper, the act of burning paper actually results in the formation of new chemicals (carbon dioxide and water, to be exact). Notice that whereas ripped paper can be at least partially reassembled, burned paper cannot be “unburned.” In other words, burning only goes in one direction. The fact that burning is not reversible is another good indication that it involves a chemical change. Another example of a chemical change, illustrated in **Figure 3.2**, is the explosion of fireworks.

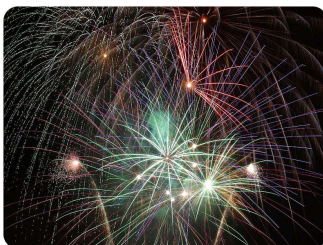

FIGURE 3.2

Fireworks are an example of a chemical change.

Lesson Summary

- There are two basic types of properties that are used to identify or describe matter: physical properties and chemical properties.

- Physical properties are those that can be observed without changing the identity of the substance.
- Chemical properties are those that can be observed only when a substance is changed into a new substance.
- Chemists make a distinction between two different types of changes that they study: physical changes and chemical changes.
- Physical changes are changes that do not alter the identity of a substance
- Chemical changes are changes that occur when one substance is turned into another substance.
- Chemical changes are frequently harder to reverse than physical changes.

Further Reading / Supplemental Links

This website provides some free PowerPoint presentations. The presentation on "Matter and Energy" provides a review of some properties of matter, as well as provide examples of the topics covered in this lesson.

- <http://science.pppst.com/energy.html>

Review Questions

For questions 1-2, determine whether the description is of a physical property or a chemical property.

1. Water boils at 100°C.
 - a. This is a physical property.
 - b. This is a chemical property.
2. Diamonds will cut glass.
 - a. This is a physical property.
 - b. This is a chemical property.

For questions 3-7, determine whether the description is of a physical change or a chemical change.

3. Water can be separated by electrolysis into hydrogen gas and oxygen gas.
 - a. This is a physical change.
 - b. This is a chemical change.
4. Sugar dissolves in water.
 - a. This is a physical change.
 - b. This is a chemical change.
5. Vinegar and baking soda react to produce a gas.
 - a. This is a physical change.
 - b. This is a chemical change.
6. Yeast acts on sugar to form carbon dioxide and ethanol.
 - a. This is a physical change.
 - b. This is a chemical change.
7. Wood burns, producing several new substances.
 - a. This is a physical change.
 - b. This is a chemical change.

3.3 Energy

Lesson Objectives

The student will:

- explain the difference between kinetic and potential energy.
- state the law of conservation of matter and energy.
- define heat.
- define work.

Vocabulary

- chemical potential energy
- energy
- kinetic energy
- law of conservation of energy
- law of conservation of matter and energy
- potential energy
- work

Introduction

Just like matter, energy is a term that we are all familiar with and use on a daily basis. Before you go on a long hike, you eat an *energy* bar; every month, the *energy* bill is paid; on TV, politicians argue about the *energy* crisis. But have you ever wondered what energy really is? If you stop to think about it, energy is very complicated. When you plug a lamp into an electric socket, you see energy in the form of light, but when you plug a heating pad into that same socket, you only feel warmth. Without energy, we couldn't turn on lights, we couldn't brush our teeth, we couldn't make our lunch, and we couldn't travel to school. In fact, without energy, we couldn't even wake up because our bodies require energy to function. We use energy for every single thing that we do, whether we're awake or asleep. Although we all use energy, very few of us understand what it is.

Types of Energy: Kinetic and Potential

Energy is the ability to do work or cause change. Machines use energy, our bodies use energy, energy comes from the sun, energy causes forest fires, and energy helps us to grow food. With all these seemingly different types of energy, it's hard to believe that there are really only two different forms of energy: kinetic energy and potential energy.

Kinetic energy is energy associated with motion. When an object is moving, it has kinetic energy, and when the object stops moving, it has no kinetic energy. Although all moving objects have kinetic energy, not all moving objects have the same amount of kinetic energy. The amount of kinetic energy possessed by an object is determined by its mass and its speed. The heavier an object is and the faster it is moving, the more kinetic energy it has.

Kinetic energy is very common and is easy to spot in the world around you. Sometimes we even capture kinetic energy and use it to power things like our home appliances. Have you ever seen windmills lining the slopes of a hill like the ones in **Figure 3.3**? These windmills capture the kinetic energy of the wind to provide power that people can use in their homes and offices. As wind rushes along the hills, the kinetic energy of the blowing air particles turns the windmills, which convert the wind's kinetic energy into electricity.

**FIGURE 3.3**

This is a photograph of a wind farm in Southern California. Kinetic energy from the rushing air particles turns the windmills, allowing us to capture the wind's kinetic energy and use it.

Capturing kinetic energy can be very effective, but you may already realize that there is a small problem: kinetic energy is only available when something is moving. When the wind stops blowing, there's no kinetic energy available. Imagine what it would be like trying to power your television set using the wind's kinetic energy. You could turn on the TV and watch your favorite program on a windy day, but every time the wind stopped blowing, your TV screen would flicker off because it would run out of energy.

You'd have noticed, however, that you can usually rely on your TV to stay on. This is largely because we don't rely on kinetic energy alone for power. Instead, we primarily use energy in its other form as potential energy. **Potential energy** is stored energy that remains available until we choose to use it. Think of a battery in a flashlight. If you leave a flashlight on, the battery will run out of energy within a couple of hours. If, instead, you only use the flashlight when you need it and turn it off when you don't, the battery will last for days or even months. Because the battery stores potential energy, you can choose to use the energy all at once, or you can save it and use a small amount at a time.

Any stored energy is potential energy and has the "potential" to be used at a later time. Unfortunately, there are a lot of different ways in which energy can be stored, making potential energy very difficult to recognize. Generally speaking, an object has potential energy due to its position relative to another object. For example, when you hold a rock above the earth, it has more potential energy than a rock on the ground. As long as you're holding the rock, the rock has potential energy stored. Once you drop the rock, though, the stored energy is released. This can confuse students because it doesn't seem like a falling rock is releasing energy. Remember, however, that energy is defined as the ability to do work or cause change.

For some examples of potential energy, though, it's harder to see how "position" is involved. In chemistry, we are

often interested in what is called chemical potential energy. **Chemical potential energy** is energy stored in the atoms, molecules, and chemical bonds that make up matter. How does this depend on position? As you learned earlier, the world and all of the chemicals in it are made up of atoms. These atoms store potential energy that is dependent on their positions relative to one another. Although we cannot see atoms, scientists know a lot about the ways in which atoms interact. This allows them to figure out how much potential energy is stored in a specific quantity of a particular chemical. *Different chemicals have different amounts of potential energy* because they are made up of different atoms, and those atoms have different positions relative to one another.

The image below represents two hydrogen atoms chemically joined to an oxygen atom to form a water molecule. Scientists use their knowledge of what the atoms and molecules look like and how they interact to determine the potential energy that can be stored in any particular chemical substance.

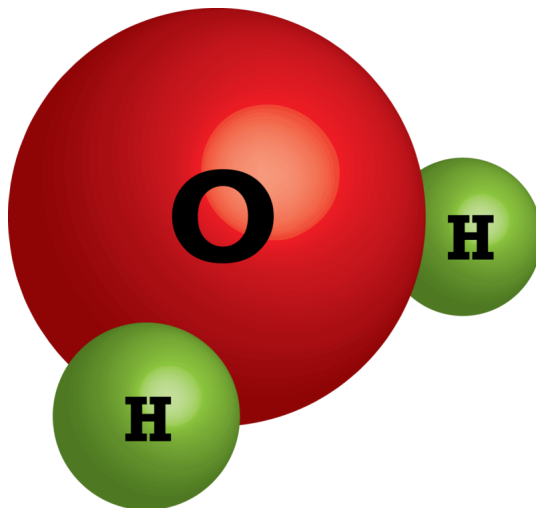

Since different chemicals have different amounts of potential energy, scientists will sometimes say potential energy depends on not only position but also composition. Composition affects potential energy because it determines which molecules and atoms end up next to each other. For example, the total potential energy in a cup of pure water is different than the total potential energy in a cup of apple juice because the cup of water and the cup of apple juice are composed of different amounts of different chemicals.

The Law of Conservation of Matter and Energy

While it's important to understand the difference between kinetic energy and potential energy, the truth is energy is constantly changing. Kinetic energy is constantly being turned into potential energy, and potential energy is constantly being turned into kinetic energy. Even though energy can change form, it must still follow the fundamental law: *energy cannot be created or destroyed*, it can only be changed from one form to another. This law is known as the **law of conservation of energy**. In a lot of ways, energy is like money. You can exchange quarters for dollar bills and dollar bills for quarters, but no matter how often you convert between the two, you won't end up with more or less money than you started with.

Think about what happens when you throw a ball into the air. When the ball leaves your hand, it has a lot of kinetic energy. At some point, the ball will stop momentarily in the air and then falls back down. When the ball stops, it no longer has any kinetic energy. According to the law of conservation of energy, the initial kinetic energy that the ball had does not just disappear. Instead, as the ball moves higher and higher into the sky, the kinetic energy is converted to potential energy. When the ball stops moving upward, all of the kinetic energy has been converted to potential energy. The ball then starts to fall back down, and the potential energy is once again changed into kinetic energy.

As it turns out, the law of conservation of energy isn't completely accurate. Energy and matter are actually interchangeable. In other words, energy can be created (made out of matter) and destroyed (turned into matter). As a result, the law of conservation of energy has been changed into the **law of conservation of matter and energy**. This law states that: *the total amount of mass and energy in the universe is conserved (does not change)*. This is one of the most important laws you will ever learn. Nevertheless, in chemistry we are rarely concerned with converting matter to energy or energy to matter. Instead, chemists deal primarily with converting one form of matter into another form of matter (through chemical reactions) and converting one form of energy into another form of energy.

Heat and Work

When we talk about using energy, we are really referring to transferring energy from one place to another. When you use energy to throw a ball, you transfer energy from your body to the ball, which causes the ball to fly through the air. When you use energy to warm your house, you transfer energy from the furnace to the air in your home, which causes the temperature in your house to rise. Although energy is used in many kinds of different situations, all of these uses rely on energy being transferred in one of two ways: as heat or as work. Unfortunately, both “heat” and “work” are used commonly in everyday speech, so you might think that you already know their meanings. In science, the words “heat” and “work” have very specific definitions that may be different from what you expect. Do not confuse the everyday meanings of the words “heat” and “work” with the scientific meanings.

When scientists speak of heat, they are referring to energy that is transferred from an object with a higher temperature to an object with a lower temperature as a result of the temperature difference. Heat will “flow” from the hot object to the cold object until both end up at the same temperature. When you cook with a metal pot, you witness energy being transferred in the form of heat. Initially, only the stove element is hot; the pot and the food inside the pot are cold. As a result, heat moves from the hot element to the cold pot, as illustrated in **Figure 3.4**. After a while, enough heat is transferred from the element to the pot, raising the temperature of the pot and all of its contents.

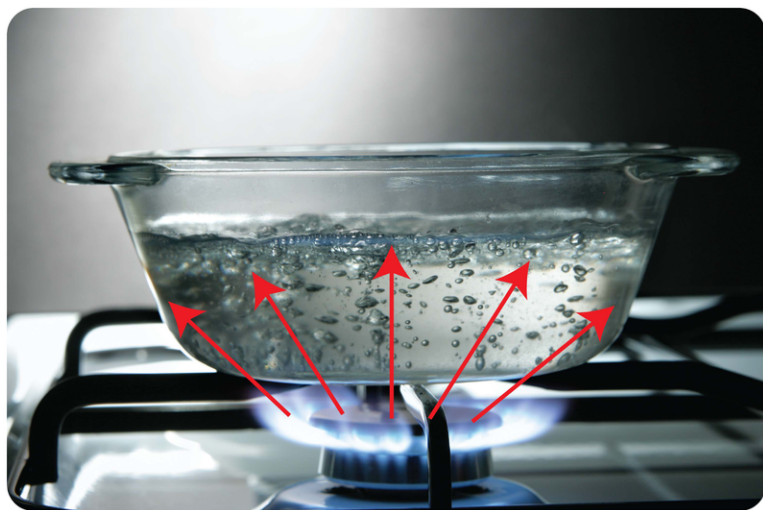
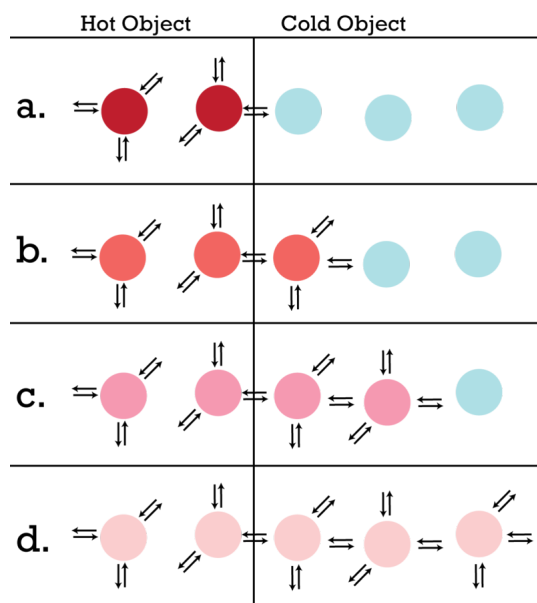

FIGURE 3.4

Energy is transferred as heat from the hot stove element to the cooler pot until the pot and its contents become just as hot as the element.

We've all observed heat moving from a hot object to a cold object, but you might wonder how the energy actually travels. Whenever an object is hot, the molecules within the object are shaking and vibrating vigorously. The hotter an object is, the more the molecules jiggle around. Anything that is moving has energy, and the more it's moving, the more energy it has. Hot objects have a lot of energy, and it's this energy that is transferred to the colder objects when the two come in contact.

The easiest way to visualize heat transfer is to imagine a domino effect. When the vibrating molecules of the hot object bump into the molecules of the colder object, they transfer some of their energy, causing the molecules in the colder object to start vibrating vigorously as well. In the image below, the red molecules are jiggling around and vibrating. As these molecules vibrate, they bump into their neighbors (the blue molecules) and transfer some of their energy. These colder molecules begin to heat up and begin to vibrate faster. Just like dominoes, the heat gets passed along the chain until the energy is spread equally between all of the molecules. At the end, all of the molecules will be at the same temperature.



Heat is only one way in which energy can be transferred. Energy can also be transferred as work. The scientific definition of **work** is force (any push or pull) applied over a distance. Whenever you push an object and cause it to move, you've done work and transferred some of your energy to the object. At this point, it is important to warn you of a common misconception. Sometimes we think that the amount of work done can be measured by the amount of effort put in. This may be true in everyday life, but this is not true in science. By definition, scientific work requires that force be applied over a distance. It doesn't matter how hard you push or pull. If you haven't moved the object, you haven't done any work. For example, no matter how much you sweat, if you cannot lift a heavy object off the ground, you have not done any work.

Lesson Summary

- Energy is the ability to do work or cause change.
- The two forms of energy are kinetic energy and potential energy.
- Kinetic energy is energy associated with motion.
- Potential energy is stored energy.
- Kinetic energy is constantly being turned into potential energy, and potential energy is constantly being turned into kinetic energy.
- Even though energy can change form, it must still follow the law of conservation of energy.
- The law of conservation of energy states that energy cannot be created or destroyed, it can only be changed from one form to another.
- When scientists speak of heat, they are referring to energy that is transferred from an object with a higher temperature to an object with a lower temperature as a result of the temperature difference.
- Heat will “flow” from the hot object to the cold object until both end up at the same temperature.

- Energy can also be transferred as work.
- Work is force (any push or pull) applied over a distance.

Further Reading / Supplemental Links

Summary of concepts of matter and energy and benchmark review.

- <http://broncho2.uco.edu/funeral/Bill%20Lewis/BoardReview/ChemLessons/Lesson%201.pdf>

Classroom videos about energy.

- <http://www.energyclassroom.com/>

Review Questions

1. Classify each of the following as energy primarily transferred as heat or energy primarily transferred as work.
 - a. The energy transferred from your body to a shopping cart as you push the shopping cart down the aisle.
 - b. The energy transferred from a wave to your board when you go surfing.
 - c. The energy transferred from the flames to your hot dog when you cook your hot dog over a campfire.
2. Decide whether each of the following statements is true or false.
 - a. When heat is transferred to an object, the object cools down.
 - b. Any time you raise the temperature of an object, you have done work.
 - c. Any time you move an object by applying force, you have done work.
 - d. Any time you apply force to an object, you have done work.
3. Rank the following scenarios in order of *increasing* work.
 - a. You apply 100 N of force to a boulder and successfully move it by 2 m.
 - b. You apply 100 N of force to a boulder and successfully move it by 1 m.
 - c. You apply 200 N of force to a boulder and successfully move it by 2 m.
 - d. You apply 200 N of force to a boulder but cannot move the boulder.
4. In science, a vacuum is defined as space that contains absolutely no matter (no molecules, no atoms, etc.) Can energy be transferred as heat through a vacuum? Why or why not?
5. Classify each of the following energies as kinetic energy or potential energy:
 - a. the energy in a chocolate bar.
 - b. the energy of rushing water used to turn a turbine or a water wheel.
 - c. the energy of a skater gliding on the ice.
 - d. the energy in a stretched rubber band.
6. Decide which of the following objects has more kinetic energy.
 - a. A 200 lb man running at 6 mph or a 200 lb man running at 3 mph.
 - b. A 200 lb man running at 7 mph or a 150 lb man running at 7 mph.
 - c. A 400 lb man running at 5 mph or a 150 lb man running at 3 mph.
7. A car and a truck are traveling along the highway at the same speed.
 - a. If the car weighs 1500 kg and the truck weighs 2500 kg, which has more kinetic energy, the car or the truck?

- b. Both the car and the truck convert the potential energy stored in gasoline into the kinetic energy of motion. Which do you think uses more gas to travel the same distance, the car or the truck?

All images, unless otherwise stated, are created by the CK-12 Foundation and are under the Creative Commons license CC-BY-NC-SA.

3.4 References

1. Photo by Magnus Rosendahl. [Melting lake side](#). Creative Commons Public Domain License
2. PDPhoto.org. [Fireworks](#). Public domain
3. Photograph by Stan Shebs. [Tehachapi wind farm](#). CC-BY-SA-3.0
4. Image copyrighted by Roman Sigaev, modified by Christopher Auyeung. Glass Saucepan on the Gas Stove. Used under 2010 license from Shutterstock.com

CHAPTER

4

The Atomic Theory

Chapter Outline

- 4.1 THE ATOMIC THEORY
 - 4.2 FURTHER UNDERSTANDING OF THE ATOM
 - 4.3 ATOMIC STRUCTURE
 - 4.4 REFERENCES
-

4.1 The Atomic Theory

Lesson Objectives

The student will:

- give a short history of how the concept of the atom developed.
- describe the contributions of Democritus and Dalton to the atomic theory.
- summarize Dalton’s atomic theory and explain its historical development.
- state the law of definite proportions.
- state the law of multiple proportions.

Vocabulary

- atomos
- Dalton’s atomic theory
- law of definite proportions
- law of multiple proportions

Introduction

You learned earlier in the chapter “Matter and Energy” that all matter in the universe is made up of tiny building blocks called atoms. All modern scientists accept the concept of the atom, but when the concept of the atom was first proposed about 2,500 years ago, ancient philosophers laughed at the idea. After all, it is difficult to be convinced that something too small to be seen really exists. We will spend some time considering the evidence (observations) that convinced scientists of the existence of atoms.

Democritus and the Greek Philosophers

Before we discuss the experiments and evidence that have convinced scientists matter is made up of atoms, it is only fair to credit the man who proposed the concept of the atom in the first place. About 2,500 years ago, early Greek philosophers believed the entire universe was a single, huge entity. In other words, “everything was one.” They believed that all objects, all matter, and all substances were connected as a single, big, unchangeable “thing.”

One of the first people to propose the existence of atoms was a man known as Democritus, pictured in **Figure 4.1**. He suggested an alternative theory where **atomos** – tiny, indivisible, solid objects – made up all matter in the universe. Democritus then reasoned that changes occur when the many atomos in an object were reconnected or recombined in different ways. Democritus even extended his theory to suggest that there were different varieties of atomos with different shapes, sizes, and masses. He thought, however, that shape, size, and mass were the only

**FIGURE 4.1**

Democritus was known as “The Laughing Philosopher.” It’s a good thing he liked to laugh, because most other philosophers were laughing at his theories.

properties differentiating the types of atomos. According to Democritus, other characteristics, like color and taste, did not reflect properties of the atomos themselves but from the different ways in which the atomos were combined and connected to one another.

So how could the Greek philosophers have known that Democritus had a good idea with his theory of atomos? The best way would have been to take some careful observation and conduct a few experiments. Recall, however, that the early Greek philosophers tried to understand the nature of the world through reason and logic, not through experimentation and observation. The Greek philosophers truly believed that, above all else, our understanding of the world should rely on logic. In fact, they argued that the world couldn’t be understood using our senses at all because our senses could deceive us. Therefore, instead of relying on observation, Greek philosophers tried to understand the world using their minds and, more specifically, the power of reason (see **Figure 4.2**).

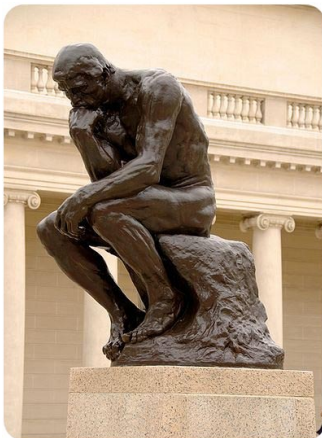
**FIGURE 4.2**

This sculpture (named “The Thinker”) reflects the value Greek philosophers placed on logic. Greek philosophers liked to think, but they didn’t like to experiment all that much.

As a result, the early Greek philosophers developed some very interesting ideas, but they felt no need to justify their ideas. You may recall from the “Introduction to Chemistry” chapter that Aristotle concluded men had more teeth than women did. He concluded this without ever checking in anyone’s mouth because his conclusion was the “logical” one. As a result, the Greek philosophers missed or rejected a lot of discoveries that could have made otherwise because they never performed any experiments. Democritus’s theory would be one of these rejected theories. It would take over two millennia before the theory of atomos (or atoms, as they’re known today) was fully appreciated.

Dalton's Atomic Theory

Let's consider a simple but important experiment that suggested matter might be made up of atoms. In the late 1700s and early 1800s, scientists began noticing that when certain substances, like hydrogen and oxygen, were combined to produce a new substance, the reactants (hydrogen and oxygen) always reacted in the same proportions by mass. In other words, if 1 gram of hydrogen reacted with 8 grams of oxygen, then 2 grams of hydrogen would react with 16 grams of oxygen, and 3 grams of hydrogen would react with 24 grams of oxygen.

Strangely, the observation that hydrogen and oxygen always reacted in the "same proportions by mass" wasn't unique to hydrogen and oxygen. In fact, it turned out that the reactants in every chemical reaction for a given compound react in the same proportions by mass. Take, for example, nitrogen and hydrogen, which can react to produce ammonia (NH_3). In chemical reactions, 1 gram of hydrogen will react with 4.7 grams of nitrogen, and 2 grams of hydrogen will react with 9.4 grams of nitrogen. Can you guess how much nitrogen would react with 3 grams of hydrogen?

Scientists studied reaction after reaction, but every time the result was the same. The reactants always reacted in the same proportions by mass or in what we call "definite proportions," as illustrated in **Figure 4.3**. As a result, scientists proposed the **law of definite proportions**. This law states that:

In a given type of chemical substance, the elements always combine in the same proportions by mass.

This version of the law is a more modern version. Earlier, you learned that an element is a substance made up of only one type of atom, but when the law of definite proportions was first discovered, scientists did not know about atoms or elements and stated the law slightly differently. We'll stick with this modern version, though, since it is the easiest version to understand.

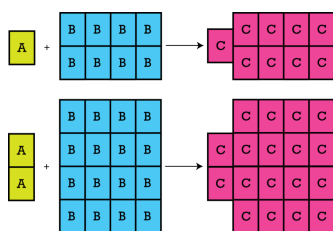

FIGURE 4.3

If 1 gram of A reacts with 8 grams of B, then by the law of definite proportions, 2 grams of A must react with 16 grams of B. If 1 gram of A reacts with 8 grams of B, then by the law of conservation of mass, they must produce 9 grams of C.

The law of definite proportions applies when the elements reacting together form the same product. Therefore, the law of definite proportions can be used to compare two experiments in which hydrogen and oxygen react to form water. The law, however, cannot be used to compare one experiment in which hydrogen and oxygen react to form water with another experiment in which hydrogen and oxygen react to form hydrogen peroxide (peroxide is another material that can be made from hydrogen and oxygen).

A man named John Dalton (**Figure 4.4**) discovered this limitation in the law of definite proportions in some of his experiments. Dalton was experimenting with several reactions in which the reactant elements formed different products, depending on the experimental conditions he used. One common reaction that he studied was the reaction between carbon and oxygen. When carbon and oxygen react, they produce two different substances – we'll call these substances *A* and *B*. It turned out that, given the same amount of carbon, forming *B* always required exactly twice as much oxygen as forming *A*. In other words, if you could make *A* with 3 grams of carbon and 4 grams of oxygen, *B* could be made with the same 3 grams of carbon but with 8 grams of oxygen instead. Dalton asked himself – why does *B* require twice as much oxygen as *A* does? Why not 1.21 times as much oxygen, or 0.95 times as much oxygen? Why a whole number like 2?

The situation became even stranger when Dalton tried similar experiments with different substances. For example, when he reacted nitrogen and oxygen, Dalton discovered that he could make three different substances – we'll call

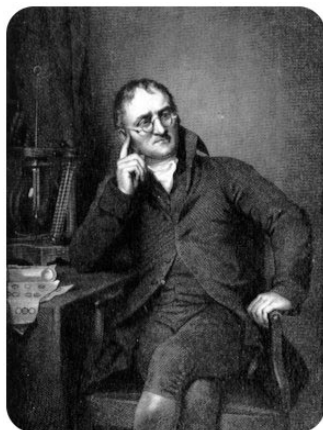
**FIGURE 4.4**

Unlike the early Greek philosophers, John Dalton was both a thinker and an experimenter. He would help develop the modern conception of an atom based on his experimental results.

them *C*, *D*, and *E*. As it turned out, for the same amount of nitrogen, *D* always required twice as much oxygen as *C* does. Similarly, *E* always required exactly four times as much oxygen as *C* does. Once again, Dalton noticed that small whole numbers (2 and 4) seemed to be the rule. Dalton used his experimental results to propose the **law of multiple proportions**:

When two elements react to form more than one substance and the same amount of one element (like oxygen) is used in each substance, then the ratio of the masses used of the other element (like nitrogen) will be in small whole numbers.

This law summarized Dalton's findings, but it did not explain why the ratio was a small whole number. Dalton thought about his law of multiple proportions and tried to develop a theory that would explain it. Dalton also knew about the law of definite proportions and the law of conservation of mass, so what he really wanted was a theory that explained all three laws with a simple, plausible model. One way to explain the relationships that Dalton and others had observed was to suggest that materials like nitrogen, carbon, and oxygen were composed of small, indivisible quantities, which Dalton called "atoms" (in reference to Democritus's original idea). Dalton used this idea to generate what is now known as **Dalton's atomic theory**.

Dalton's atomic theory:

1. Matter is made of tiny particles called atoms.
2. Atoms are indivisible. During a chemical reaction, atoms are rearranged, but they do not break apart, nor are they created or destroyed.
3. All atoms of a given element are identical in mass and other properties.
4. The atoms of different elements differ in mass and other properties.
5. Atoms of one element can combine with atoms of another element to form compounds. In a given compound, however, the different types of atoms are always present in the same relative numbers.

Historical note: Some people think that Dalton developed his atomic theory before stating the law of multiple proportions, while others argue that the law of multiple proportions, though not formally stated, was actually discovered first. In reality, Dalton was probably contemplating both concepts at the same time, although it is hard to say conclusively from looking at the laboratory notes he left behind.

Lesson Summary

- 2,500 years ago, Democritus suggested that all matter in the universe was made up of tiny, indivisible, solid objects he called atomos.
- Other Greek philosophers disliked Democritus's atomos theory because they felt it was illogical.
- The law of definite proportions states that in a given chemical substance, the elements are always combined in the same proportions by mass.
- The law of multiple proportions states that when two elements react to form more than one substance and the same amount of one element is used in each substance, then the ratio of the masses used of the other element will be in small whole numbers.
- Dalton used the law of definite proportions, the law of multiple proportions, and the law of conservation of mass to propose his atomic theory.
- Dalton's atomic theory states:
 1. Matter is made of tiny particles called atoms.
 2. Atoms are indivisible. During a chemical reaction, atoms are rearranged, but they do not break apart, nor are they created or destroyed.
 3. All atoms of a given element are identical in mass and other properties.
 4. The atoms of different elements differ in mass and other properties.
 5. Atoms of one element can combine with atoms of another element to form compounds. In a given compound, however, the different types of atoms are always present in the same relative numbers.

Review Questions

1. It turns out that a few of the ideas in Dalton's atomic theory aren't entirely correct. Are inaccurate theories an indication that science is a waste of time?
2. Suppose you are trying to decide whether to wear a sweater or a T-shirt. To make your decision, you phone two friends. The first friend says, "Wear a sweater, because I've already been outside today, and it's cold." The second friend, however, says, "Wear a T-shirt. It isn't logical to wear a sweater in July." Would you decide to go with your first friend and wear a sweater or with your second friend and wear a T-shirt? Why?
3. Decide whether each of the following statements is true or false.
 - a. Democritus believed that all matter was made of atomos.
 - b. Democritus also believed that there was only one kind of atomos.
 - c. Most early Greek scholars thought that the world was "ever-changing."
 - d. If the early Greek philosophers hadn't been so interested in making gold, they probably would have liked the idea of the atomos.
4. Match the person, or group of people, with their role in the development of chemistry in the table below.

Person/Group of People	Role in Chemistry
(a) early Greek philosophers	(i) first suggested that all matter was made up of tiny, indivisible, solid objects
(b) alchemists	(ii) tried to apply logic to the world around them
(c) John Dalton	(iii) proposed the first scientific theory relating chemical changes to the structure, properties, and behavior of atoms
(d) Democritus	(iv) were primarily concerned with finding ways to turn common metals into gold

5. Early Greek philosophers felt that Democritus's atomos theory was illogical because:
 - a. no matter how hard they tried, they could never break matter into smaller pieces.
 - b. it didn't help them to make gold.
 - c. sulfur is yellow and carbon is black, so clearly atomos must be colored.
 - d. empty space is illogical because it implies that nothing is actually something.
6. Identify the law that explains the following observation: Carbon monoxide can be formed by reacting 12 grams of carbon with 16 grams of oxygen. To form carbon dioxide, however, 12 grams of carbon must react with 32 grams of oxygen.
7. Identify the law that explains the following observation: Carbon monoxide can be formed by reacting 12 grams of carbon with 16 grams of oxygen. It can also be formed by reacting 24 grams of carbon with 32 grams of oxygen.
8. Identify the law that explains the following observation: 28 grams of carbon monoxide are formed when 12 grams of carbon reacts with 16 grams of oxygen.
9. Identify the law that explains the following observations: When 12 grams of carbon react with 4 grams of hydrogen, they produce methane, and there is no carbon or hydrogen left over at the end of the reaction. If, however, 11 grams of carbon react with 4 grams of hydrogen, there is hydrogen left over at the end of the reaction.
10. Which of the following is *not* part of Dalton's atomic theory?
 - a. Matter is made of tiny particles called atoms.
 - b. During a chemical reaction, atoms are rearranged.
 - c. During a nuclear reaction, atoms are split apart.
 - d. All atoms of a specific element are the same.
11. Consider the following data: 3.6 grams of boron react with 1.0 grams of hydrogen to give 4.6 grams of BH_3 . How many grams of boron would react with 2.0 grams of hydrogen?
12. Consider the following data: 12 grams of carbon and 4 grams of hydrogen react to give 16 grams of compound *A*. 24 grams of carbon and 6 grams of hydrogen react to give 30 grams of compound *B*. Are compound *A* and compound *B* the same? Why or why not?

4.2 Further Understanding of the Atom

Lesson Objectives

The student will:

- explain the observations that led to Thomson's discovery of the electron.
- describe Thomson's plum-pudding model of the atom.
- draw a diagram of Thomson's plum-pudding model of the atom and explain why it has this name.
- describe Rutherford's gold foil experiment and explain how this experiment disproved the plum-pudding model.
- draw a diagram of the Rutherford model of the atom and label the nucleus and the electron cloud.

Vocabulary

- cathode ray tube
- electron
- nucleus
- proton
- subatomic particle

Introduction

Dalton's atomic theory held up well in a lot of the different chemical experiments that scientists performed to test it. For almost 100 years, it seemed as if Dalton's atomic theory was the whole truth. It wasn't until 1897 when a scientist named J. J. Thomson conducted some research that suggested Dalton's atomic theory wasn't the entire story. Dalton had gotten a lot right - he was right in saying matter is made up of atoms; he was right in saying there are different kinds of atoms with different mass and other properties; he was *almost* right in saying atoms of a given element are identical; he was right in saying that atoms are merely rearranged during a chemical reaction; and he was right in saying a given compound always has atoms present in the same relative numbers. But he was *wrong* in saying atoms were indivisible or indestructible. As it turns out, atoms are divisible. In fact, atoms are composed of even smaller, more fundamental particles. These particles, called **subatomic particles**, are particles that are smaller than the atom. The discoveries of these subatomic particles are the focus of this chapter.

Thomson's Plum-Pudding Model

In the mid-1800s, scientists were beginning to realize that the study of chemistry and the study of electricity were actually related. First, a man named Michael Faraday showed how passing electricity through mixtures of different chemicals could cause chemical reactions. Shortly after that, scientists found that by forcing electricity through

a tube filled with gas, the electricity made the gas glow. Scientists didn't, however, understand the relationship between chemicals and electricity until a British physicist named J. J. Thomson began experimenting with what is known as a cathode ray tube (**Figure 4.5**).

**FIGURE 4.5**

A portrait of J. J. Thomson.

The figure below shows a basic diagram of a cathode ray tube like the one Thomson would have used. A **cathode ray tube** is a small glass tube with a cathode (a negatively charged metal plate) and an anode (a positively charged metal plate) at opposite ends. By separating the cathode and anode a short distance, the cathode ray tube can generate what are known as cathode rays – rays of electricity that flow from the cathode to the anode. Thomson wanted to know what cathode rays were, where cathode rays came from, and whether cathode rays had any mass or charge. The techniques that he used to answer these questions were very clever and earned him a Nobel Prize in physics. First, by cutting a small hole in the anode, Thomson found that he could get some of the cathode rays to flow through the hole in the anode and into the other end of the glass cathode ray tube. Next, he figured out that if he painted a substance known as phosphor onto the far end of the cathode ray tube, he could see exactly where the cathode rays hit because the cathode rays made the phosphor glow.

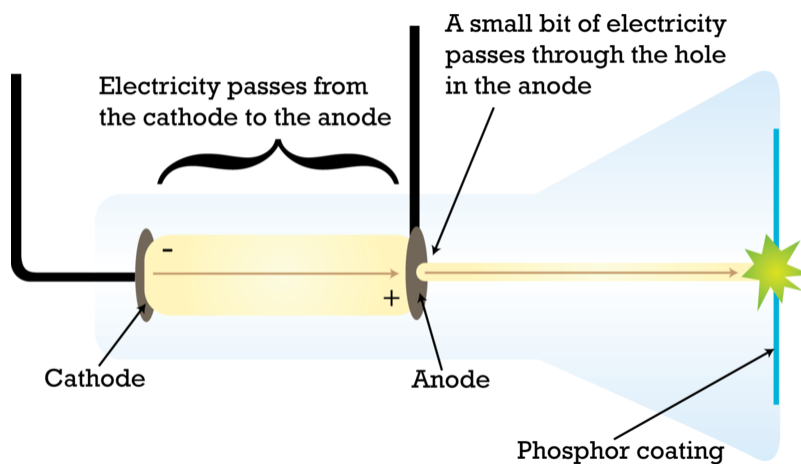

Thomson must have suspected that cathode rays were charged, because his next step was to place a positively charged metal plate on one side of the cathode ray tube and a negatively charged metal plate on the other side, as shown below. The metal plates didn't actually touch the cathode ray tube, but they were close enough that a remarkable thing happened. The flow of the cathode rays passing through the hole in the anode was bent upwards towards the positive metal plate and away from the negative metal plate. In other words, instead of glowing directly across from the hole in the anode, the phosphor now glowed at a spot quite a bit higher in the tube.

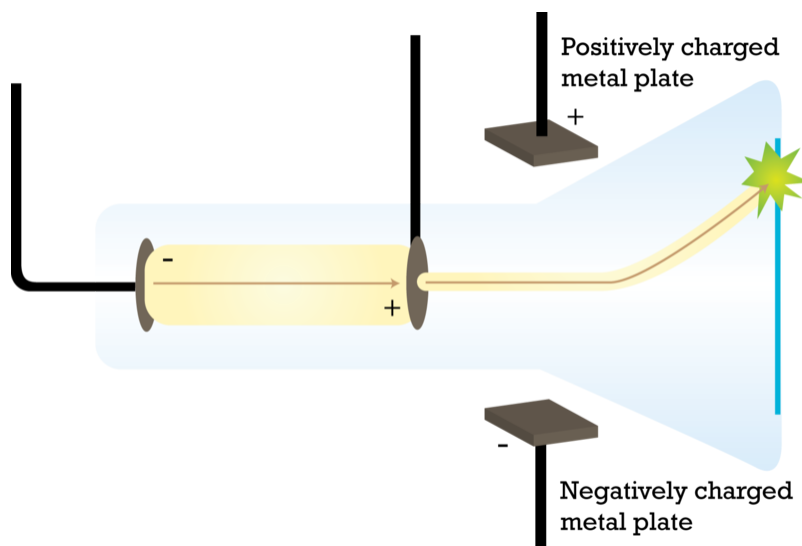

Thomson thought about his results for a long time. It was almost as if the cathode rays were attracted to the positively charged metal plate and repelled from the negatively charged metal plate. Thomson knew that charged objects are attracted to and repelled from other charged objects according to the rule: opposite charges attract, like charges repel. This means that a positive charge is attracted to a negative charge but repelled from another positive charge. Similarly, a negative charge is attracted to a positive charge but repelled from another negative charge. Using the “opposite charges attract, like charges repel” rule, Thomson argued that if the cathode rays were attracted to the positively charged metal plate and repelled from the negatively charged metal plate, the rays themselves must have a negative charge.

Thomson then did some rather complex experiments with magnets and used the results to prove that cathode rays not only were negatively charged, but they also had mass. Remember that anything with mass is part of what we call matter. In other words, these cathode rays must be the result of negatively charged matter flowing from the cathode to the anode. It was here that Thomson encountered a problem. According to his measurements, these cathode rays either had a ridiculously high charge or very, very little mass – much less mass than the smallest known atom. How was this possible? How could the matter making up cathode rays be smaller than an atom if atoms were indivisible? Thomson made a radical proposal: maybe atoms are divisible. He suggested that the small, negatively charged particles making up the cathode ray were actually pieces of atoms. He called these pieces “corpuscles,” although today we know them as **electrons**. Thanks to his clever experiments and careful reasoning, Thomson is credited with the discovery of the electron.

For a demonstration of cathode ray tubes (1h), see <http://www.youtube.com/watch?v=XU8nMKkzbT8> (1:09).



MEDIA

Click image to the left for more content.

Now imagine what would happen if atoms were made entirely of electrons. First of all, electrons are very, very small; in fact, electrons are about 2,000 times smaller than the smallest known atom, so every atom would have to contain a lot of electrons. But there’s another, bigger problem: electrons are negatively charged. Therefore, if atoms were made entirely out of electrons, the atoms themselves would be negatively charged, which would mean all matter was negatively charged as well.

Of course, matter isn’t negatively charged. Most matter is what we call neutral – it has no charge at all. How can

matter be neutral if matter is composed of atoms and atoms are composed of negative electrons? The only possible explanation is that atoms must consist of more than just electrons. Atoms must also contain some type of positively charged material that balances the negative charge of the electrons. Negative and positive charges of equal size cancel each other out, just like negative and positive numbers of equal size. If an atom contains an electron with a -1 charge and some form of material with a $+1$ charge, overall the atom must have a $(+1) + (-1) = 0$ charge. In other words, the atom would be neutral, or have no overall charge.

Based on the fact that atoms are neutral and based on Thomson's discovery that atoms contain negative subatomic particles called electrons, scientists assumed that atoms must also contain a positive substance. It turned out that this positive substance was another kind of subatomic particle known as the **proton**. Although scientists knew that atoms had to contain positive material, protons weren't actually discovered, or understood, until quite a bit later.

When Thomson discovered the negative electron, he also realized that atoms had to contain positive material as well. As a result, Thomson formulated what's known as the plum-pudding model for the atom. According to the plum-pudding model, the negative electrons were like pieces of fruit and the positive material was like the batter or the pudding. In the figure below, an illustration of a plum pudding is on the left and an illustration of Thomson's plum-pudding model is on the right. (Instead of a plum pudding, you can also think of a chocolate chip cookie. In that case, the positive material in the atom would be the batter in the chocolate chip cookie, while the negative electrons would be scattered through the batter like chocolate chips.)

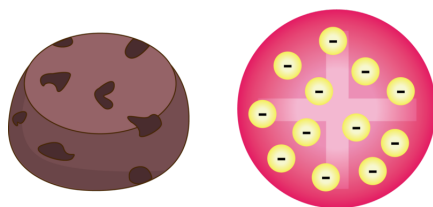

This made a lot of sense given Thomson's experiments and observations. Thomson had been able to isolate electrons using a cathode ray tube; however, he had never managed to isolate positive particles. Notice in the image above how easy it would be to pick the pieces of fruit out of a plum pudding. On the other hand, it would be a lot harder to pick the batter out of the plum pudding because the batter is everywhere. If an atom were similar to a plum pudding in which the electrons are scattered throughout the "batter" of positive material, then you would expect it to be easy to pick out the electrons and a lot harder to pick out the positive material.

Everything about Thomson's experiments suggested the plum-pudding model was correct. According to the scientific method, however, any new theory or model should be tested by further experimentation and observation. In the case of the plum-pudding model, it would take a man named Ernest Rutherford to prove it wrong. Rutherford and his experiments will be the topic of the next section.

There was one thing that Thomson was unable to determine. He had measured the charge-to-mass ratio of the electron, but he had been unable to measure accurately the charge on the electron. Instead, a different scientist named Robert Millikan would determine the charge of the electron with his oil drop experiment. When combined with Thomson's charge-to-mass ratio, Millikan was able to calculate the mass of the electron. Millikan's experiment involved putting charges on tiny droplets of oil suspended between charged metal plates and measuring their rate of descent. By varying the charge on different drops, he noticed that the electric charges on the drops were all multiples of 1.6×10^{-19} C (coulomb), the charge of a single electron.

Rutherford's Nuclear Model

Disproving Thomson's plum-pudding model began with the discovery that an element known as uranium emits positively charged particles called alpha particles as it undergoes radioactive decay. Radioactive decay occurs when one element decomposes into another element. It only happens with a few very unstable elements. Alpha particles themselves didn't prove anything about the structure of the atom, but they were used to conduct some very interesting experiments.

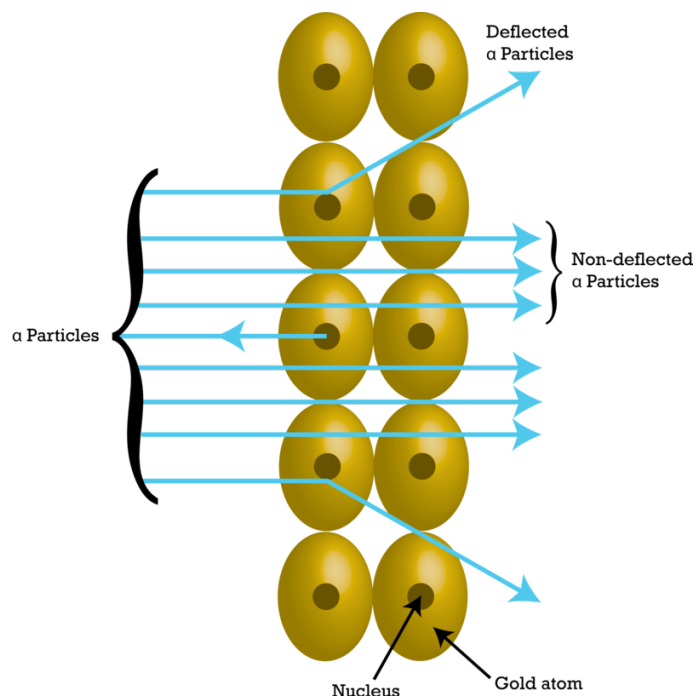

FIGURE 4.6

A portrait of Ernest Rutherford.

Ernest Rutherford (pictured in **Figure 4.6**) was fascinated by all aspects of alpha particles and used them as tiny bullets that could be fired at all kinds of different materials. The results of one experiment in particular surprised Rutherford and everyone else.

Rutherford found that when he fired alpha particles at a very thin piece of gold foil, an interesting phenomenon happened. The diagram below helps illustrate Rutherford's findings. Almost all of the alpha particles went straight through the foil as if they had hit nothing at all. Every so often, though, one of the alpha particles would be deflected slightly as if it had bounced off something hard. Even less often, Rutherford observed alpha particles bouncing straight back at the "gun" from which they had been fired. It was as if these alpha particles had hit a wall head-on and had ricocheted right back in the direction that they had come from.



Rutherford thought that these experimental results were rather odd. He expected firing alpha particles at gold foil to be like shooting a high-powered rifle at tissue paper. The bullets would break through the tissue paper and keep on going, almost as if they had hit nothing at all. That was what Rutherford had expected to see when he fired alpha particles at the gold foil. The fact that most alpha particles passed through did not shock him, but how could he explain the alpha particles that were deflected? Furthermore, how could he explain the alpha particles that bounced right back as if they had hit a wall?

Rutherford decided that the only way to explain his results was to assume that the positive matter forming the gold atoms was not distributed like the batter in plum pudding. Instead, he proposed that the positive matter was concentrated in one spot, forming a small, positively charged particle somewhere in the center of the gold atom. We now call this clump of positively charged mass the **nucleus**. According to Rutherford, the presence of a nucleus explained his experiments because it implied that most of the positively charged alpha particles would pass through the gold foil without hitting anything at all. Occasionally, though, the alpha particles would actually collide with a gold nucleus, causing the alpha particles to be deflected or even bounced back in the direction they came from.

While Rutherford's discovery of the positively charged atomic nucleus offered insight into the structure of the atom, it also led to some questions. According to the plum-pudding model, electrons were like plums embedded in the positive batter of the atom. Rutherford's model, though, suggested that the positive charge was concentrated into a tiny particle at the center of the atom, while most of the rest of the atom was empty space. What did that mean for the electrons? If they weren't embedded in the positive material, exactly what were they doing? How were they held in the atom? Rutherford suggested that the electrons might be circling or orbiting the positively charged nucleus as some type of negatively charged cloud, like in the image below. At the time, however, there wasn't much evidence to suggest exactly how the electrons were held in the atom.

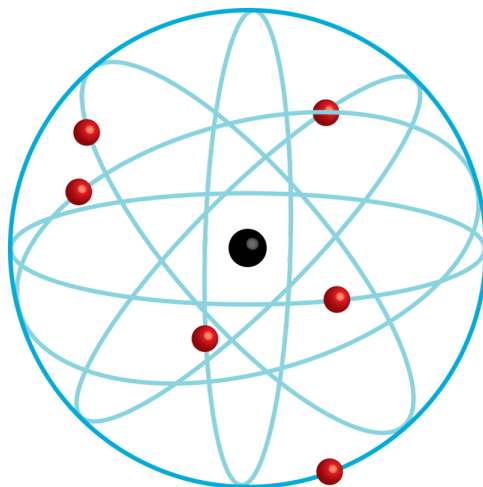

A short animation of Rutherford's experiment (**1h**) can be found at http://www.youtube.com/watch?v=5pZj0u_XMbc (0:47).

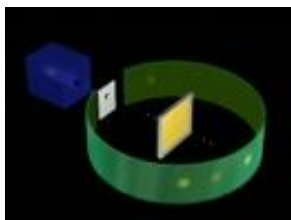

MEDIA

Click image to the left for more content.

For another video discussing J.J. Thomson's use of a cathode ray tube in his discovery of the electron (**1h**), see <http://www.youtube.com/watch?v=IdTxGJjA4Jw> (2:54).



MEDIA

Click image to the left for more content.

Despite the problems and questions associated with Rutherford's experiments, his work with alpha particles seemed to point to the existence of an atomic nucleus. Between Thomson, who discovered the electron, and Rutherford, who suggested that the positive charges were concentrated at the atom's center, the 1890s and early 1900s saw huge steps in understanding the atom at the subatomic (smaller than the size of an atom) level. Although there was still some uncertainty with respect to exactly how subatomic particles were organized in the atom, it was becoming more and more obvious that atoms were indeed divisible. Moreover, it was clear that an atom contained negatively charged electrons and a positively charged nucleus. In the next lesson, we'll look more carefully at the structure of the nucleus. We'll learn that while the atom is made up of positive and negative particles, it also contains neutral particles that neither Thomson nor Rutherford were able to detect with their experiments.

Lesson Summary

- Dalton's atomic theory wasn't entirely correct, as it was found that atoms can be divided into smaller subatomic particles.

- According to Thomson's plum-pudding model, the negatively charged electrons in an atom are like the pieces of fruit in a plum pudding, while the positively charged material is like the batter.
- When Ernest Rutherford fired alpha particles at a thin gold foil, most alpha particles went straight through; however, a few were scattered at different angles, and some even bounced straight back.
- In order to explain the results of his gold foil experiment, Rutherford suggested that the positive matter in the gold atoms was concentrated at the center of the gold atom in what we now call the nucleus of the atom.

Further Reading / Supplemental Links

The *learner.org* website allows users to view the Annenberg series of chemistry videos. You are required to register before you can watch the videos, but there is no charge to register. The video called "The Atom" explores the structure of the atom.

- <http://learner.org/resources/series61.html>

Review Questions

1. Decide whether each of the following statements is true or false.
 - a. Cathode rays are positively charged.
 - b. Cathode rays are rays of light, thus they have no mass.
 - c. Cathode rays can be repelled by a negatively charged metal plate.
 - d. J.J. Thomson is credited with the discovery of the electron.
 - e. Phosphor is a material that glows when struck by cathode rays.
2. Match each observation with the correct conclusion.
 - a. Cathode rays are attracted to a positively charged metal plate.
 - a. Cathode rays are positively charged.
 - b. Cathode rays are negatively charged.
 - c. Cathode rays have no charge.
 - b. Electrons have a negative charge.
 - a. Atoms must be negatively charged.
 - b. Atoms must be positively charged.
 - c. Atoms must also contain positive subatomic material.
 - c. Alpha particles fired at a thin gold foil are occasionally scattered back in the direction that they came from.
 - a. The positive material in an atom is spread throughout like the batter in pudding.
 - b. Atoms contain neutrons.
 - c. The positive charge in an atom is concentrated in a small area at the center of the atom.
3. What is the name given to the tiny clump of positive material at the center of an atom?
4. Choose the correct statement.
 - a. Ernest Rutherford discovered the atomic nucleus by performing experiments with aluminum foil.
 - b. Ernest Rutherford discovered the atomic nucleus using a cathode ray tube.
 - c. When alpha particles are fired at a thin gold foil, they never go through.
 - d. Ernest Rutherford proved that the plum-pudding model was incorrect.
 - e. Ernest Rutherford experimented by firing cathode rays at gold foil.

5. Answer the following questions:
- Will the charges $+2$ and -2 cancel each other out?
 - Will the charges $+2$ and -1 cancel each other out?
 - Will the charges $+1$ and $+1$ cancel each other out?
 - Will the charges -1 and $+3$ cancel each other out?
 - Will the charges $+9$ and -9 cancel each other out?
6. Electrons are _____ negatively charged metals plates and _____ positively charged metal plates.
7. What was J. J. Thomson's name for electrons?
8. A "sodium cation" is a sodium atom that has lost one of its electrons. Would the charge on a sodium cation be positive, negative, or neutral? Would sodium cations be attracted to a negative metal plate or a positive metal plate? Would electrons be attracted to or repelled from sodium cations?
9. Suppose you have a cathode ray tube coated with phosphor so that you can see where on the tube the cathode ray hits by looking for the glowing spot. What will happen to the position of this glowing spot if:
- a negatively charged metal plate is placed above the cathode ray tube?
 - a negatively charged metal plate is placed to the right of the cathode ray tube?
 - a positively charged metal plate is placed to the right of the cathode ray tube?
 - a negatively charged metal plate is placed above the cathode ray tube, and a positively charged metal plate is placed to the left of the cathode ray tube?
 - a positively charged metal plate is placed below the cathode ray tube, and a positively charged metal plate is also placed to the left of the cathode ray tube?

4.3 Atomic Structure

Lesson Objectives

The student will:

- identify the three major subatomic particles and their charges, masses, and location in the atom.
- briefly describe the discovery of the neutron.
- define atomic number.
- describe the size of the nucleus in relation to the size of the atom.
- explain what is meant by the atomic mass of an element and describe how atomic masses are related to carbon-12.
- define mass number.
- explain what isotopes are and how isotopes affect an element's atomic mass.
- determine the number of protons, neutrons, and electrons in an atom.
- calculate the atomic mass of an element from the masses and relative percentages of the isotopes of the element.

Vocabulary

- atomic mass
- atomic mass unit
- atomic number
- dalton
- isotopes
- mass number
- neutron
- strong nuclear force

Introduction

Dalton's atomic theory explained a lot about matter, chemicals, and chemical reactions. Nevertheless, it wasn't entirely accurate because, contrary to what Dalton believed, atoms can in fact be broken apart into smaller subunits or subatomic particles. The first type of subatomic particle to be found in an atom was the negatively charged electron. Since atoms are neutral, though, they must also contain positive material. In his gold foil experiment, Rutherford proved that the positive substance in an atom was concentrated in a small area at the center of the atom, leaving most the rest of the atom as empty space. In this lesson, we'll examine the subatomic particles making up the atom a little more closely.

This video gives basic information about the nucleus of atoms including comparative sizes of atom vs nucleus (**1e**), see <http://www.youtube.com/watch?v=Tfy0sIVfVOY> (2:03).

**MEDIA**

Click image to the left for more content.

Electrons, Protons, and Neutrons

Electrons have a negative charge. As a result, they are attracted to positive objects and repelled from negative objects, including other electrons (illustrated below). To minimize repulsion, each electron is capable of staking out a “territory” and “defending” itself from other electrons.

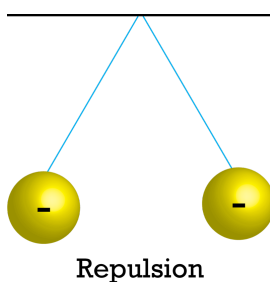

Protons are another type of subatomic particle found in atoms. They have a positive charge, so they are attracted to negative objects and repelled from positive objects. Again, this means that protons repel each other (illustrated below). However, unlike electrons, protons are forced to group together into one big clump, even though they repel each other. Protons are bound together by what are termed **strong nuclear forces**. These forces are responsible for binding the atomic nuclei together, allowing the protons to form a dense, positively charged center.

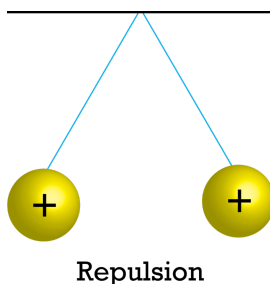

There is a third subatomic particle known as a **neutron**. Rutherford proposed the existence of a neutral particle along with the approximate mass of a proton, but it wasn't until years later that someone proved the existence of the neutron. A physicist named James Chadwick observed that when beryllium was bombarded with alpha particles, it emitted an unknown radiation that had approximately the same mass as a proton, but the radiation had no electrical charge. Chadwick was able to prove that these beryllium emissions contained a neutral particle – Rutherford's neutron.

As you might have already guessed from its name, the neutron is neutral. In other words, it has no charge and is therefore neither attracted to nor repelled from other objects. Neutrons are in every atom (with one exception), and they're bound together with other neutrons and protons in the atomic nucleus. Again, the binding forces that help to keep neutrons fastened into the nucleus are known as strong nuclear forces.

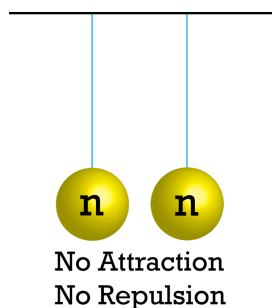

Since neutrons are neither attracted to nor repelled from objects, they don't really interact with protons or electrons beyond being bound into the nucleus with the protons. Protons and electrons, however, do interact. Using what you know about protons and electrons, what do you think will happen when an electron approaches a proton? Will the two subatomic particles be attracted to each other or repelled from each other? Here's a hint: "opposites attract, likes repel." Since electrons and protons have opposite charges (one negative, the other positive), you'd expect them to be attracted to each other, as illustrated below.

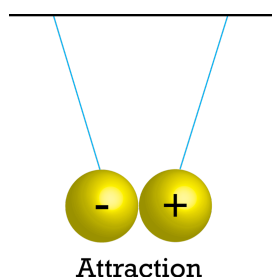

Even though electrons, protons, and neutrons are all types of subatomic particles, they are not all the same size. When comparing the masses of electrons, protons, and neutrons, you will find that electrons have an extremely small mass compared to the masses of either protons or neutrons (see **Figure 4.7**). On the other hand, the masses of protons and neutrons are fairly similar, with the mass of a neutron being slightly greater than the mass of a proton. Because protons and neutrons are so much more massive than electrons, almost all of the atomic mass in any atom comes from the nucleus, which is where all of the neutrons and protons are located.



FIGURE 4.7

Electrons are much smaller than protons or neutrons. How much smaller? If an electron was the size of a penny, a proton or a neutron would have the mass of a large bowling ball!

Table 4.1 gives the properties and locations of electrons, protons, and neutrons. The third column shows the masses of the three subatomic particles in grams. The second column, however, shows the masses of the three subatomic particles in amu, or atomic mass units. An **atomic mass unit (amu)** is defined as one-twelfth the mass of a carbon-12 atom (a carbon that has 6 protons and 6 neutrons). Atomic mass units are useful because, as you can see, the mass of a proton and the mass of a neutron are almost exactly 1.0 in this unit system. The **dalton** is equivalent to the atomic mass unit, with the two terms being different names for the same measure. The two terms are often used interchangeably, and both will be used throughout this text.

TABLE 4.1: Subatomic Particles, Properties, and Location

Particle	Relative (amu)	Mass	Mass in Grams (g)	Electric Charge	Location
electron	$\frac{1}{1840}$		9.109383×10^{-28}	-1	outside nucleus
proton	1		$1.6726217 \times 10^{-24}$	+1	nucleus
neutron	1		$1.6749273 \times 10^{-24}$	0	nucleus

In addition to mass, another important property of subatomic particles is the charge. The fourth column in **Table 4.1** shows the charges of the three subatomic particles. You already know that neutrons are neutral and thus have no charge at all. Therefore, we say that neutrons have a charge of zero. What about electrons and protons? Electrons are negatively charged and protons are positively charged, but the positive charge on a proton is exactly equal in magnitude (magnitude means “absolute value”) to the negative charge on an electron. You may recall that Millikan discovered that the magnitude of the charge on a single electron is 1.6×10^{-19} C (coulomb), which means that the magnitude of the charge on a proton is also 1.6×10^{-19} C. In other words, a neutral atom must have exactly one electron for every proton. If a neutral atom has 1 proton, it must have 1 electron. If a neutral atom has 2 protons, it must have 2 electrons. If a neutral atom has 10 protons, it must have 10 electrons. Do you get the idea?

For a short animation demonstrating the properties of the electron using a cathode ray tube (**1h**), see <http://www.youtube.com/watch?v=4QAzu6fe8rE> video (3:46).

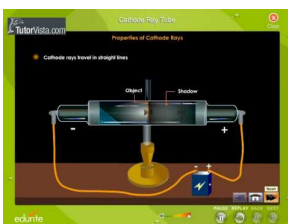
**MEDIA**

Click image to the left for more content.

Atomic Number and Mass Number

Scientists can distinguish between different elements by counting the number of protons. If an atom has only one proton, we know it's an atom of the element hydrogen. An atom with two protons is always an atom of the element helium. When scientists count four protons in an atom, they know it's a beryllium atom. An atom with three protons is a lithium atom, an atom with five protons is a boron atom, an atom with six protons is a carbon atom. . . the list goes on (see **Figure 4.8** for more examples).

Since an atom of one element can be distinguished from an atom of another element by the number of protons in the nucleus, scientists are always interested in this number and how this number differs between different elements. Therefore, scientists give this number a special name and a special symbol. An element's **atomic number (Z)** is equal to the number of protons in the nuclei of any of its atoms. The periodic table gives the atomic number of each element. The atomic number is a whole number usually written above the chemical symbol of each element in the table. The atomic number for hydrogen is $Z = 1$ because every hydrogen atom has 1 proton. The atomic number for helium is $Z = 2$ because every helium atom has 2 protons. What is the atomic number of carbon? (*Answer:* Carbon has 6 protons, so the atomic number for carbon is $Z = 6$.)

Since neutral atoms have to have one electron for every proton, an element's atomic number also tells you how many electrons are in a neutral atom of that element. For example, hydrogen has atomic number $Z = 1$. This means that an atom of hydrogen has one proton and, if it's neutral, one electron. Gold, on the other hand, has atomic number $Z = 79$, which means that a neutral atom of gold has 79 protons and 79 electrons.

The **mass number (A)** of an atom is the total number of protons and neutrons in its nucleus. Why do you think

**FIGURE 4.8**

How would you distinguish these three elements? You can't really distinguish between sulfur and gold based on color because both are yellowish. You could try to distinguish elements based on another parameter, such as shininess, but then how would you tell the difference between gold and silicon? Each element, however, does have a unique number of protons. Sulfur has 16 protons, silicon has 14 protons, and gold has 79 protons.

that the mass number includes protons and neutrons, but not electrons? You know that most of the mass of an atom is concentrated in its nucleus and that the mass of an electron is very, very small compared to the mass of either a proton or a neutron (like the mass of a penny compared to the mass of a bowling ball). By counting the number of protons and neutrons, scientists will have a very close approximation of the total mass of an atom.

$$\text{mass number } A = (\text{number of protons}) + (\text{number of neutrons})$$

An atom's mass number is very easy to calculate once you know the number of protons and neutrons in the atom. Notice that the mass number is not the same as the mass of the atom. You can easily relate the mass number to the mass by recalling that both protons and neutrons have a relative mass of 1 amu.

Example:

What is the mass number of an atom that contains 3 protons and 4 neutrons?

$$(\text{number of protons}) = 3$$

$$(\text{number of neutrons}) = 4$$

$$\text{mass number } A = (\text{number of protons}) + (\text{number of neutrons})$$

$$\text{mass number } A = (3) + (4) = 7$$

Example:

What is the mass number of an atom of helium that contains 2 neutrons?

$$(\text{number of protons}) = 2 \text{ (Remember that an atom of helium always has 2 protons.)}$$

$$(\text{number of neutrons}) = 2$$

$$\text{mass number } A = (\text{number of protons}) + (\text{number of neutrons})$$

$$\text{mass number } A = (2) + (2) = 4$$

This video summarizes the concept of the atom and to the organization of the periodic table (**1a, 1e**): <http://www.youtube.com/watch?v=1xSQLwWGT8M> (21:05).

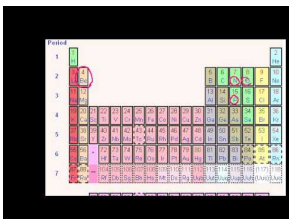

MEDIA

Click image to the left for more content.

Isotopes and Atomic Mass

Unlike the number of protons, which is always the same for all atoms of the same element, the number of neutrons can be different. Atoms of the same element with different numbers of neutrons are known as **isotopes**. Since the isotopes of any given element all contain the same number of protons, they have the same atomic number. However, since the isotopes of a given element contain different numbers of neutrons, different isotopes have different mass numbers. The following two examples should help to clarify this point.

Example:

What is the atomic number (Z) and the mass number (A) of an isotope of lithium containing 3 neutrons? A lithium atom contains 3 protons in its nucleus.

$$\begin{aligned} \text{atomic number } Z &= \text{number of protons} = 3 \\ \text{number of neutrons} &= 3 \\ \text{mass number } A &= (\text{number of protons}) + (\text{number of neutrons}) \\ \text{mass number } A &= (3) + (3) = 6 \end{aligned}$$

Example:

What is the atomic number (Z) and the mass number (A) of an isotope of lithium containing 4 neutrons? A lithium atom contains 3 protons in its nucleus.

$$\begin{aligned} \text{atomic number } Z &= \text{number of protons} = 3 \\ \text{number of neutrons} &= 4 \\ \text{mass number } A &= (\text{number of protons}) + (\text{number of neutrons}) \\ \text{mass number } A &= (3) + (4) = 7 \end{aligned}$$

Notice that because the lithium atom always has 3 protons, the atomic number for lithium is always $Z = 3$. The mass number, however, is $A = 6$ for the isotope with 3 neutrons, and $A = 7$ for the isotope with 4 neutrons. In nature, only certain isotopes exist. For instance, lithium exists as an isotope with 3 neutrons and as an isotope with 4 neutrons, but it doesn't exist as an isotope with 2 neutrons or as an isotope with 5 neutrons.

This whole discussion of isotopes brings us back to Dalton's atomic theory. According to Dalton, atoms of a given element are identical. But if atoms of a given element can have different numbers of neutrons, then they can have different masses as well. How did Dalton miss this? It turns out that elements found in nature exist as uniform mixtures with a constant ratio of their naturally occurring isotopes. In other words, a piece of lithium always contains both types of naturally occurring lithium (the type with 3 neutrons and the type with 4 neutrons). Moreover, it always contains the two in the same relative amounts (or "relative abundances"). In a chunk of lithium, 93% will always be lithium with 4 neutrons, while the remaining 7% will always be lithium with 3 neutrons.

Unfortunately, Dalton always experimented with large chunks of an element – chunks that contained all of the naturally occurring isotopes of that element. As a result, when he performed his measurements, he was actually observing the averaged properties of all the different isotopes in the sample. Luckily, aside from having different masses, most other properties of different isotopes are similar.

Knowing about the different isotopes is important when it comes to calculating atomic mass. The **atomic mass** (sometimes referred to as atomic weight) of an element is the weighted average mass of the atoms in a naturally occurring sample of the element. Atomic mass is typically reported in atomic mass units. You can calculate the atomic mass of an element, provided you know the relative abundances the element's naturally occurring isotopes and the masses of those different isotopes. The examples below show how this calculation is done.

Example:

Boron has two naturally occurring isotopes. In a sample of boron, 20% of the atoms are B-10, which is an isotope of boron with 5 neutrons and a mass of 10 amu. The other 80% of the atoms are B-11, which is an isotope of boron with 6 neutrons and a mass of 11 amu. What is the atomic mass of boron?

Solution:

To do this problem, we will calculate 20% of the mass of B-10, which is how much the B-10 isotope contributes to the "average boron atom." We will also calculate 80% of the mass of B-11, which is how much the B-11 isotope contributes to the "average boron atom."

Step One: Convert the percentages given in the question into their decimal forms by dividing each percentage by 100%:

$$\text{Decimal form of } 20\% = 0.20$$

$$\text{Decimal form of } 80\% = 0.80$$

Step Two: Multiply the mass of each isotope by its relative abundance (percentage) in decimal form:

$$20\% \text{ of the mass of B-10} = 0.20 \times 10 \text{ amu} = 2.0 \text{ amu}$$

$$80\% \text{ of the mass of B-11} = 0.80 \times 11 \text{ amu} = 8.8 \text{ amu}$$

Step Three: Find the total mass of the "average atom" by adding together the contributions from the different isotopes:

$$\text{Total mass of average atom} = 2.0 \text{ amu} + 8.8 \text{ amu} = 10.8 \text{ amu}$$

The mass of an average boron atom, and thus boron's atomic mass, is 10.8 amu.

Example:

Neon has three naturally occurring isotopes. In a sample of neon, 90.48% of the atoms are Ne-20, which is an isotope of neon with 10 neutrons and a mass of 19.99 amu. Another 0.27% of the atoms are Ne-21, which is an isotope of neon with 11 neutrons and a mass of 20.99 amu. The final 9.25% of the atoms are Ne-22, which is an isotope of neon with 12 neutrons and a mass of 21.99 amu. What is the atomic mass of neon?

Solution:

To do this problem, we will calculate 90.48% of the mass of Ne-20, which is how much Ne-20 contributes to the "average neon atom." We will also calculate 0.27% of the mass of Ne-21 and 9.25% of the mass of Ne-22, which are how much the Ne-21 and the Ne-22 isotopes contribute to the "average neon atom" respectively.

Step One: Convert the percentages given in the question into their decimal forms by dividing each percentage by 100%:

$$\text{Decimal form of } 90.48\% = 0.9048$$

$$\text{Decimal form of } 0.27\% = 0.0027$$

$$\text{Decimal form of } 9.25\% = 0.0925$$

Step Two: Multiply the mass of each isotope by its relative abundance (percentage) in decimal form:

90.48% of the mass of Ne-20 = $0.9048 \times 20.00 \text{ amu} = 18.10 \text{ amu}$

0.27% of the mass of Ne-21 = $0.0027 \times 21.00 \text{ amu} = 0.057 \text{ amu}$

9.25% of the mass of Ne-22 = $0.0885 \times 22.00 \text{ amu} = 2.04 \text{ amu}$

Step Three: Find the total mass of the “average atom” by adding together the contributions from the different isotopes:

Total mass of average atom = $18.10 \text{ amu} + 0.057 \text{ amu} + 2.04 \text{ amu} = 20.20 \text{ amu}$

The mass of an average neon atom, and thus neon’s atomic mass, is 20.20 amu.

The periodic table gives the atomic mass of each element. The atomic mass is a number that usually appears below the element’s symbol in each square. Notice that atomic mass of boron (symbol B) is 10.8 and the atomic mass of neon (symbol Ne) is 20.18, both which are very close to what we calculated in our examples. Take time to notice that not all periodic tables have the atomic number above the element’s symbol and the atomic mass below it. If you are ever confused, remember that the atomic number should always be the smaller of the two and will be a whole number, while the atomic mass should always be the larger of the two. (The atomic mass must include both the number of protons and the average number of neutrons.)

Lesson Summary

- Electrons are a type of subatomic particle with a negative charge, so electrons repel each other but are attracted to protons.
- Protons are a type of subatomic particle with a positive charge, so protons repel each other but are attracted to electrons. Protons are bound together in an atom’s nucleus as a result of strong nuclear forces.
- Neutrons are a type of subatomic particle with no charge (they’re neutral). Like protons, neutrons are bound into the atom’s nucleus as a result of strong nuclear forces.
- Protons and neutrons have approximately the same mass and are both much more massive than electrons (approximately 2,000 times as massive as an electron).
- The positive charge on a proton is equal in magnitude to the negative charge on an electron. As a result, a neutral atom must have an equal number of protons and electrons.
- Each element has a unique number of protons. An element’s atomic number (Z) is equal to the number of protons in the nuclei of any of its atoms.
- The mass number (A) of an atom is the sum of the protons and neutrons in the atom
- Isotopes are atoms of the same element (same number of protons) that have different numbers of neutrons in their atomic nuclei.
- An element’s atomic mass is the average mass of one atom of that element. An element’s atomic mass can be calculated provided the relative abundances of the element’s naturally occurring isotopes and the masses of those isotopes are known.
- The periodic table is a convenient way to summarize information about the different elements. In addition to the element’s symbol, most periodic tables will also contain the element’s atomic number and the element’s atomic mass.

Further Reading / Supplemental Links

This website has a video called “Atomic Structure: The Nucleus” available.

- <http://videos.howstuffworks.com/hsw/5806-atomic-structure-the-nucleus-video.htm>

Review Questions

- Decide whether each of the following statements is true or false.
 - The nucleus of an atom contains all of the protons in the atom.
 - The nucleus of an atom contains all of the neutrons in the atom.
 - The nucleus of an atom contains all of the electrons in the atom.
 - Neutral atoms of a given element must contain the same number of neutrons.
 - Neutral atoms of a given element must contain the same number of electrons.
- Match the subatomic property with its description in **Table 4.2**.

TABLE 4.2: Table for Problem 2

Subatomic Particle	Characteristics
i. electron	a. has an atomic charge of $+1 e$
ii. neutron	b. has a mass of 9.109383×10^{-28} grams
iii. proton	c. is neither attracted to nor repelled from charged objects

- Arrange the electron, proton, and neutron in order of decreasing mass.
- Indicate which of the following statements is true or false.
 - An element's atomic number is equal to the number of protons in the nuclei of any of its atoms.
 - The symbol for an element's atomic number is A .
 - A neutral atom with $Z = 4$ must have 4 electrons.
 - A neutral atom with $A = 4$ must have 4 electrons.
 - An atom with 7 protons and 7 neutrons will have $A = 14$.
 - An atom with 7 protons and 7 neutrons will have $Z = 14$.
 - A neutral atom with 7 electrons and 7 neutrons will have $A = 14$.
- Use the periodic table to find the symbol for the element with:
 - 44 electrons in a neutral atom.
 - 30 protons.
 - $Z = 36$.
 - an atomic mass of 14.007 amu.
- When will the mass number (A) of an atom be:
 - bigger than the atomic number (Z) of the atom?
 - smaller than the atomic number (Z) of the atom?
 - equal to the atomic number (Z) of the atom?
- In **Table 4.3**, Column 1 contains data for five different elements. Column 2 contains data for the same five elements but with different isotopes of those elements. Match the columns by connecting isotopes of the same element.

TABLE 4.3: Table for Problem 7

Column 1

- an atom with 2 protons and 1 neutron
- a Be (beryllium) atom with 5 neutrons
- an atom with $Z = 6$ and $A = 13$

Column 2

- a C (carbon) atom with 6 neutrons
- an atom with 2 protons and 2 neutrons
- an atom with $Z = 7$ and $A = 15$

TABLE 4.3: (continued)

Column 1	Column 2
d. an atom with 1 proton and $A = 1$	iv. an atom with $A = 2$ and 1 neutron
e. an atom with $Z = 7$ and 7 neutrons	v. an atom with $Z = 4$ and 6 neutrons

8. Match the following isotopes with their respective mass numbers in **Table 22.5**.

TABLE 4.4: Table for Problem 8

Column 1	Column 2
(a) an atom with $Z = 17$ and 18 neutrons	i. 35
(b) an H atom with no neutrons	ii. 4
(c) A He atom with 2 neutrons	iii. 1
(d) an atom with $Z = 11$ and 11 neutrons	iv. 23
(e) an atom with 11 neutrons and 12 protons	v. 22

9. Match the following isotopes with their respective atomic numbers in **Table 4.5**.

TABLE 4.5: Table for Problem 9

Column 1	Column 2
(a) a B (boron) atom with $A = 10$	i. 8
(b) an atom with $A = 10$ and 6 neutrons	ii. 2
(c) an atom with 3 protons and 3 neutrons	iii. 3
(d) an oxygen atom	iv. 4
(e) an atom with $A = 4$ and 2 neutrons	v. 5

10. Answer the following questions:

- What's the mass number of an atom that contains 13 protons and 13 neutrons?
- What's the mass number of an atom that contains 24 protons and 30 neutrons?

11. Answer the following questions:

- What's the mass number of the isotope of manganese (Mn) containing 28 neutrons?
- What's the mass number of the isotope of calcium (Ca) containing 20 neutrons?

12. Answer the following questions:

- What's the atomic number of an atom that has 30 neutrons, and a mass number of $A = 70$?
- What's the atomic number of an atom with 14 neutrons, if the mass number of the atom is $A = 28$?

13. Answer the following questions:

- What's the mass number of a neutral atom that contains 7 protons and 7 neutrons?
- What's the mass number of a neutral atom that contains 7 electrons and 7 neutrons?
- What's the mass number of a neutral atom that contains 5 protons, 5 electrons, and 6 neutrons?
- What's the mass number of a neutral atom that contains 3 electrons and 4 neutrons?

14. Answer the following questions:

- What element has 32 neutrons in an atom with mass number $A = 58$?
- What element has 10 neutrons in an atom with mass number $A = 19$?

15. Copper has two naturally occurring isotopes. 69.15% of copper atoms are Cu-63 and have a mass of 62.93 amu. The other 30.85% of copper atoms are Cu-65 and have a mass of 64.93 amu. What is the atomic mass of copper?

All images, unless otherwise stated, are created by the CK-12 Foundation and are under the Creative Commons license CC-BY-NC-SA.

4.4 References

1. Hendrick ter Brugghen. [Democritus](#). Public domain
2. Sculpture by Auguste Rodin, photograph by Karora. [The Thinker](#). Public domain
3. Created by Richard Parsons, illustrated by Christopher Auyeung. Illustration of the law of definite proportions. CC-BY-NC-SA
4. . [John Dalton](#). Public domain
5. . [A portrait of J. J. Thomson](#). Public domain
6. . [Ernest Rutherford](#). Public domain
7. Image of the penny is from the United States Mint (<http://en.wikipedia.org/wiki/Image:2005-Penny-Uncirculated-Obverse-cropped.png>), image of bowling ball is by Scl chua (<http://en.wikipedia.org/wiki/Image:Bowlingball.jpg>). Composite image of bowling ball and penny. Both images are in the public domain
8. Sulfur image originally from the Smithsonian Institution (<http://en.wikipedia.org/wiki/Image:Sulfur.jpg>), gold image taken by Aram Dulyan (http://en.wikipedia.org/wiki/Image:Native_gold_nuggets.jpg), and silicon image created by Enricoros (<http://en.wikipedia.org/wiki/Image:SiliconCroda.jpg>). Composite of sulfur, gold, and silicon. All images are in the public domain

CHAPTER **5** The Bohr Model of the Atom

Chapter Outline

- 5.1 THE NATURE OF LIGHT**
 - 5.2 ATOMS AND ELECTROMAGNETIC SPECTRA**
 - 5.3 THE BOHR MODEL OF THE ATOM**
 - 5.4 REFERENCES**
-

5.1 The Nature of Light

Lesson Objectives

The student will:

- perform calculations involving the relationship between the wavelength and frequency of electromagnetic radiation, $v = \lambda f$.
- perform calculations involving the relationship between the energy and the frequency of electromagnetic radiation, $E = hf$.
- state the velocity of electromagnetic radiation in a vacuum.
- name at least three different areas of the electromagnetic spectrum.
- when given two comparative colors or areas in the electromagnetic spectrum, identify which area has the higher wavelength, the higher frequency, and the higher energy.

Vocabulary

- amplitude
- crest
- electromagnetic spectrum
- frequency (f)
- hertz (Hz)
- trough
- velocity (v)
- wavelength (λ)

Introduction

In order to understand how Rutherford's model of the atom evolved to the current atomic model, we need to understand some basic properties of light. During the 1600s, there was a debate about how light travels. Isaac Newton, the English physicist, hypothesized that light consisted of tiny particles and that a beam of light would therefore be a stream of particles. Around the same time, Christian Huygens, a Dutch physicist, suggested that light traveled as a waveform in the same way energy travels in water.

Neither hypothesis became the dominant idea until 200 years later, when the Scottish physicist James Clerk Maxwell proposed a wave model of light in 1864 that gained widespread support. Maxwell's equations related electricity, magnetism, and light so comprehensively that several physicists suggested students should major in other sciences because everything in physics had been discovered. Scientists thought that Maxwell's work permanently settled the "wave versus particle" debate over the nature of light. Fortunately, quite a few students did not take their advice. Sixty years later, German physicist Max Planck would raise the issue again and renew the debate over the nature of light.

The Wave Form of Energy

The wave model of electromagnetic radiation is somewhat similar to waves in a rope. Suppose we tie one end of a rope to a tree and hold the other end at a distance from the tree so that the rope is fully extended. If we then jerk the end of the rope up and down in a rhythmic way, the rope will go up and down. When the end of the rope we are holding goes up and down, it pulls on the neighboring part of the rope, which will also go up and down. The up and down motion will be passed along to each succeeding part of the rope, and after a short time, the entire rope will contain a wave like the one shown in the image below.

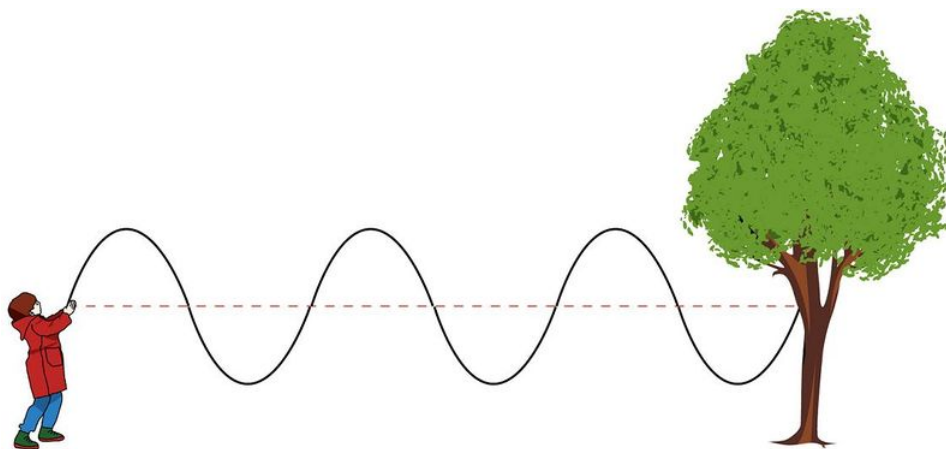

The red line in the diagram shows the undisturbed position of the rope before the wave motion was initiated. The **crest** is the highest point of the wave above the undisturbed position, while the **trough** is the lowest point of a wave below the undisturbed position. It is important for you to recognize that the individual particles of rope *do not move horizontally*. Each point on the rope only moves up and down. If the wave is allowed to dissipate, every point of the rope will be in the exact same position it was in before the wave started. The wave in the rope moves horizontally from the person to the tree, but no parts of rope actually move horizontally. The notion that parts of the rope are moving horizontally is a visual illusion. Like the wave, the energy that is put into the rope by jerking it up and down also moves horizontally from the person to the tree.

If we jerk the rope up and down with a different rhythm, the wave in the rope will change its appearance in terms of crest height, distance between crests, and so forth, but the general shape of the wave will remain the same. We can characterize the wave in the rope with a few measurements. The image below shows an instantaneous snapshot of the rope so that we can indicate some characteristic values.

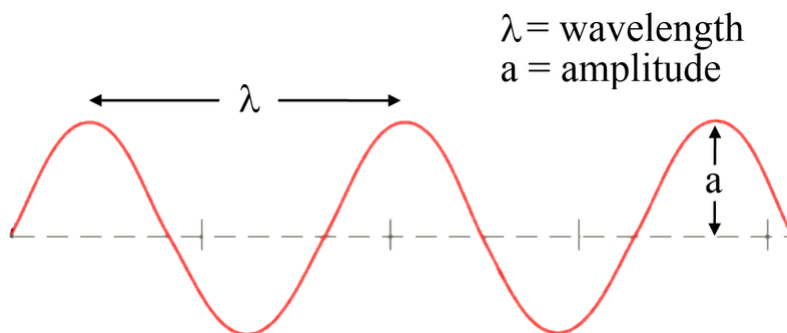

The distance from one crest to the next crest is called the **wavelength** of the wave. You could also determine the wavelength by measuring the distance from one trough to the next or between any two identical positions on

successive waves. The symbol used for wavelength is the Greek letter lambda, λ . The distance from the maximum height of a crest to the undisturbed position is called the **amplitude** of the wave. The **velocity** of a wave is the distance traveled by the wave in one second. We can obtain the velocity of the wave by measuring how far a crest travels horizontally in a unit of time. The SI unit for velocity is meters/second.

Another important characteristic of waves is called frequency. The **frequency** of a wave is the number of cycles that pass a given point per unit of time. If we choose an exact position along the path of the wave and count how many crests pass the position per unit time, we would get a value for frequency. Based on this description, the unit for frequency would be cycles per second or waves per second. In science, however, frequency is often denoted by $1/s$ or s^{-1} , with “cycles” being implied rather than explicitly written out. This unit is called a **hertz** (abbreviated Hz), but it means cycles per second and is written out in calculations as $1/s$ or s^{-1} . The symbol used for frequency is the Greek letter nu, ν . Unfortunately, this Greek letter looks a very great deal like the italicized letter ν . You must be very careful when reading equations to see whether the symbol is representing velocity (ν) or frequency (ν). To avoid this problem, this text will use a lower case letter f as the symbol for frequency.

The velocity, wavelength, and frequency of a wave are all related, as indicated by the formula: $v = \lambda f$. If the wavelength is expressed in meters and the frequency is expressed in $1/\text{second}$ (s^{-1}), then multiplying the wavelength times the frequency will yield meters/second, which is the unit for velocity.

Example:

What is the velocity of a rope wave if its wavelength is 0.50 m and its frequency is $12 s^{-1}$?

$$v = \lambda f = (0.50 \text{ m}) \cdot (12 s^{-1}) = 6.0 \text{ m/s}$$

Example:

What is the wavelength of a water wave if its velocity is 5.0 m/s and its frequency is $2.0 s^{-1}$?

$$\lambda = \frac{v}{f} = \frac{5.0 \text{ m/s}}{2.0 s^{-1}} = 2.5 \text{ meters}$$

Electromagnetic Waves

Electromagnetic radiation is a form of energy that consists of electric and magnetic fields traveling at the speed of light. Electromagnetic waves carry this energy from one place to another and are somewhat like waves in a rope. Unlike the wave in a rope, however, electromagnetic waves are not required to travel through a medium. For example, light waves are electromagnetic waves capable of traveling from the sun to Earth through outer space, which is considered a vacuum.

The energy of an electromagnetic wave travels in a straight line along the path of the wave, just like the energy in the rope wave did. The moving light wave has associated with it an oscillating electric field and an oscillating magnetic field. Scientists often represent the electromagnetic wave with the image below. Along the straight-line path of the wave, there exists a positive electric field that will reach a maximum positive charge, slowly collapse to zero charge, and then expand to a maximum negative charge. Along the path of the electromagnetic wave, this changing electric field repeats its oscillating charge over and over again. There is also a changing magnetic field that oscillates from maximum north pole field to maximum south pole field. Do not confuse the oscillating electric and magnetic fields with the way light travels. Light does not travel in this weaving wave pattern. The light travels along the black line that represents the undisturbed position. For an electromagnetic wave, the crests and troughs represent the oscillating fields, not the path of the light.

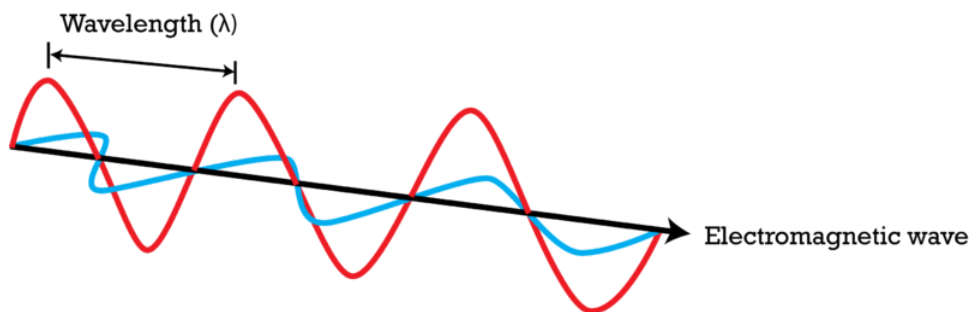

Although light waves look different from the wave in the rope, we still characterize light waves by their wavelength, frequency, and velocity. We can measure along the path of the wave the distance the wave travels between one crest and the succeeding crest. This will be the wavelength of the electromagnetic radiation. The frequency of electromagnetic waves is still the number of full cycles of waves that pass a point in a unit of time, just like how frequency is defined for rope waves. The velocity for all electromagnetic waves traveling through a vacuum is the same. Although technically the velocity of electromagnetic waves traveling through air is slightly less than the velocity in a vacuum, the two velocities are so close that we will use the same value for the velocity. In a vacuum, every electromagnetic wave has a velocity of 3.00×10^8 m/s, which is symbolized by the lower case c . The relationship, then, for the velocity, wavelength, and frequency of electromagnetic waves is: $c = \lambda f$.

Example:

What is the wavelength of an electromagnetic wave traveling in air whose frequency is 1.00×10^{14} s⁻¹?

$$\lambda = \frac{c}{f} = \frac{3.00 \times 10^8 \text{ m/s}}{1.00 \times 10^{14} \text{ s}^{-1}} = 3.00 \times 10^{-6} \text{ m}$$

The Electromagnetic Spectrum

In rope waves and water waves, the amount of energy possessed by the wave is related to the amplitude of the wave; there is more energy in the rope if the end of the rope is jerked higher and lower. In electromagnetic radiation, however, the amount of energy possessed by the wave is only related to the frequency of the wave. In fact, the frequency of an electromagnetic wave can be converted directly to energy (measured in joules) by multiplying the frequency with a conversion factor. The conversion factor is called Planck's constant and is equal to 6.6×10^{-34} joule · seconds. Sometimes, Planck's constant is given in units of joules/hertz, but you can show that the units are the same. The equation for the conversion of frequency to energy is $E = hf$, where E is the energy in joules (symbolized by J), h is Planck's constant in joules-second, and f is the frequency in s⁻¹.

Electromagnetic waves have an extremely wide range of wavelengths, frequencies, and energies. The **electromagnetic spectrum** is the range of all possible frequencies of electromagnetic radiation. The highest energy form of electromagnetic waves is gamma rays and the lowest energy form (that we have named) is radio waves.

In the image below, the electromagnetic waves on the far left have the highest energy. These waves are called gamma rays, and they can cause significant damage to living systems. The next lowest energy form of electromagnetic waves is called X-rays. Most of you are familiar with the penetration abilities of these waves. Although they can be helpful in imaging bones, they can also be quite dangerous to humans. For this reason, humans are advised to try to limit as much as possible the number of medical X-rays they have per year. After X-rays, ultraviolet rays are the next lowest in energy. These rays are a part of sunlight, and rays on the upper end of the ultraviolet range can cause sunburn and eventually skin cancer. The next tiny section in the spectrum is the visible range of light. The band referred to as visible light has been expanded and extended below the full spectrum. These are the frequencies (energies) of the electromagnetic spectrum to which the human eye responds. Lower in the spectrum are infrared rays and radio waves.

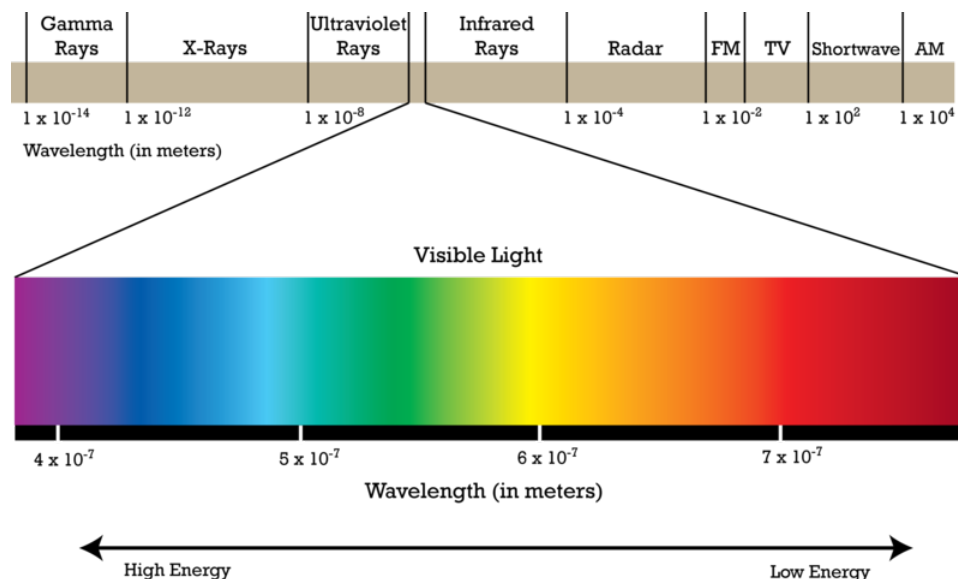

The light energies that are in the visible range are electromagnetic waves that cause the human eye to respond when they enter the eye. The eye then sends signals to the brain, and the individual “sees” various colors. The waves in the visible region with the highest energy are interpreted by the brain as violet. As the energy of the waves decreases, the colors change to blue, green, yellow, orange, and red. When the energy of the wave is above or below the visible range, the eye does not respond to them. When the eye receives several different frequencies at the same time, the colors are “blended” by the brain. If all frequencies of visible light enter the eye together, the brain sees white, and if no visible light enters the eye, the brain sees black.

All the objects that you see around you are light absorbers – that is, the chemicals on the surface of the objects absorb certain frequencies and not others. Your eyes will then detect the frequencies that strike them. Therefore, if your friend is wearing a red shirt, it means that the dye in that shirt reflected the red and absorbed all the other frequencies. When the red frequency from the shirt arrives at your eye, your visual system sees red, and you would say the shirt is red. If your only light source was one exact frequency of blue light and you shined it on a shirt that absorbed every frequency of light except for one frequency of red, then the shirt would look black to you because no light would be reflected to your eye.

Lesson Summary

- The wave form of energy is characterized by velocity, wavelength, and frequency.
- The velocity, wavelength, and frequency of a wave are related by the expression: $v = \lambda f$.
- Electromagnetic radiation comes in a wide spectrum that includes low energy radio waves and very high energy gamma rays.
- The frequency and energy of electromagnetic radiation are related by the expression: $E = hf$.

Further Reading / Supplemental Links

This website provides more information about the properties of electromagnetic waves and includes an animation showing the relationship between wavelength and color.

- <http://micro.magnet.fsu.edu/primer/java/wavebasics/index.html>

Review Questions

1. Name at least three different areas in the spectrum of electromagnetic radiation.
2. Which color of visible light has the longer wavelength, red or blue?
3. What is the velocity of all forms of electromagnetic radiation traveling in a vacuum?
4. How can you determine the frequency of a wave when the wavelength is known?
5. If the velocity of a water wave is 9.0 m/s and the wave has a wavelength of 3.0 m, what is the frequency of the wave?
6. If a sound wave has a frequency of 256 Hz and a wavelength of 1.34 m, what is its velocity?
7. What is the relationship between the energy of electromagnetic radiation and the frequency of that radiation?
8. What is the energy, in joules, of a light wave whose frequency is 5.66×10^8 Hz?

5.2 Atoms and Electromagnetic Spectra

Lesson Objectives

The student will:

- describe the appearance of an atomic emission spectrum.
- explain why an element can be identified by its emission spectrum.

Vocabulary

- emission spectrum

Introduction

Electric light bulbs contain a very thin wire that emits light upon heating. The wire is called a filament. The particular wire used in light bulbs is made of tungsten. A wire made of any metal would emit light under these circumstances, but one of the reasons that tungsten is used is because the light it emits contains virtually every frequency, making the emitted light appear white. Every element emits light when energized, either by heating the element or by passing electric current through it. Elements in solid form begin to glow when they are sufficiently heated, while elements in gaseous form emit light when electricity passes through them. This is the source of light emitted by neon signs (see **Figure 5.1**) and is also the source of light in a fire. You may have seen special logs created for fireplaces that give off bright red and green colors as they burn. These logs were created by introducing certain elements into them in order to produce those colors when heated.



FIGURE 5.1

The light emitted by the sign containing neon gas (on the left) is different from the light emitted by the sign containing argon gas (on the right).

Each Element Has a Unique Spectrum

Several physicists, including Anders J. Angstrom in 1868 and Johann J. Balmer in 1875, passed the light from energized atoms through glass prisms in such a way that the light was spread out and the individual frequencies making up the light could be seen.



FIGURE 5.2

This is the unique emission spectrum for hydrogen.

In **Figure 5.2**, we see the emission spectrum for hydrogen gas. The **emission spectrum** of a chemical element is the pattern of frequencies obtained when the element is subjected to a specific excitation. When hydrogen gas is placed into a tube and electric current passed through it, the color of emitted light is pink. But when the light is separated into individual colors, we see that the hydrogen spectrum is composed of four individual frequencies. The pink color of the tube is the result of our eyes blending the four colors.

Every atom has its own characteristic spectrum; no two atomic spectra are alike. Because each element has a unique emission spectrum, elements can be identified by using them. **Figure 5.3** shows the emission spectrum of iron.

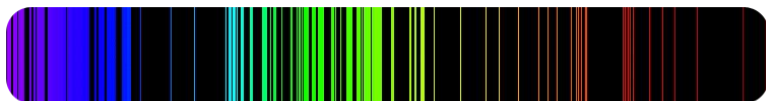

FIGURE 5.3

This is the unique emission spectrum of iron.

You may have heard or read about scientists discussing what elements are present in the sun or some more distant star. How could scientists know what elements are present if they have never been to these faraway places? Scientists determine what elements are present in distant stars by analyzing the light that comes from those stars and using the atomic spectrum to identify the elements emitting that light.

Lesson Summary

- Atoms have the ability to absorb and emit electromagnetic radiation.
- Each element has a unique emission spectrum.

Further Reading / Supplemental Links

This website “Spectral Lines” has a short discussion of atomic spectra. It also has the emission spectra of several elements.

- <http://www.colorado.edu/physics/2000/quantumzone/index.html>

Review Questions

1. The emission spectrum for an element shows bright lines for the light frequencies that are emitted. The absorption spectrum of that same element shows dark lines within the complete spectrum for the light frequencies that are absorbed. How can you explain that the bright lines in the emission spectrum of an element exactly correspond to the dark lines in the absorption spectrum for that same element?

5.3 The Bohr Model of the Atom

Lesson Objectives

The student will:

- describe an electron cloud containing Bohr's energy levels.
- describe how the Bohr model of the atom explains the existence of atomic spectra.
- explain the limitations of the Bohr model and why it had to be replaced.

Vocabulary

- energy level

Introduction

By 1913, our concept of the atom had evolved from Dalton's idea of indivisible spheres to Thomson's plum-pudding model and then to Rutherford's nuclear atom theory.

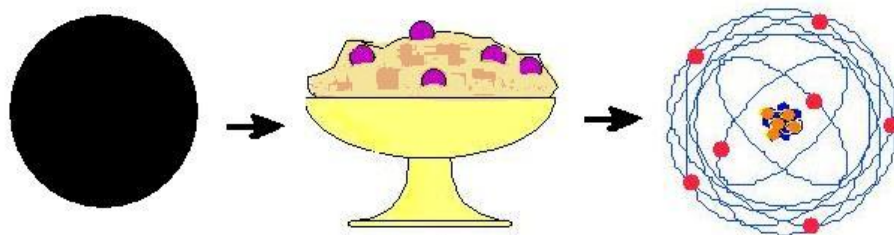

Rutherford, in addition to carrying out the experiment that demonstrated the presence of the atomic nucleus, proposed that the electrons circled the nucleus in a planetary-like motion. The planetary model of the atom was attractive to scientists because it was similar to something with which they were already familiar, namely the solar system. Unfortunately, there was a serious flaw in the planetary model. At that time, it was already known that when a charged particle moves in a curved path, the particle emits some form of light or radio waves and loses energy in doing so. If the electron circling the nucleus in an atom loses energy, it would necessarily have to move closer to the nucleus (because of the loss of potential energy) and would eventually crash into the nucleus. Scientists, however, saw no evidence that electrons were constantly emitting energy or crashing into the nucleus. These difficulties cast a shadow on the planetary model and indicated that it would eventually be replaced.

The replacement model came in 1913 when the Danish physicist Niels Bohr (pictured in **Figure 5.4**) proposed an electron cloud model where the electrons orbit the nucleus but did not have to lose energy.

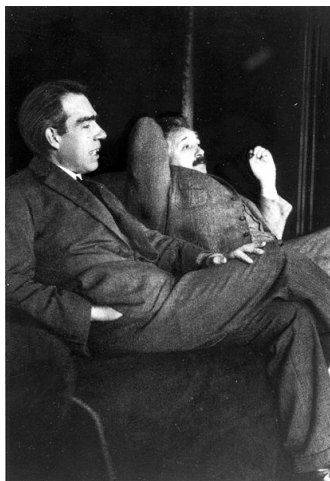
**FIGURE 5.4**

Niels Bohr and Albert Einstein in 1925.

Bohr's Energy Levels

The key idea in the Bohr model of the atom is that electrons occupy definite orbits that require the electron to have a specific amount of energy. In order for an electron to be in the electron cloud of an atom, it must be in one of the allowable orbits and have the precise energy required for that orbit. Orbits closer to the nucleus would require the electrons to have a smaller amount of energy, and orbits farther from the nucleus would require the electrons to have a greater amount of energy. The possible orbits are known as **energy levels**.

Bohr hypothesized that the only way electrons could gain or lose energy would be to move from one energy level to another, thus gaining or losing precise amounts of energy. It would be like a ladder that had rungs at certain heights (see image below). The only way you can be on that ladder is to be on one of the rungs, and the only way you could move up or down is to move to one of the other rungs. Other rules for the ladder are that only one person can be on a given rung and that the ladder occupants must be on the lowest rung available. Suppose we had such a ladder with 10 rungs. If the ladder had five people on it, they would be on the lowest five rungs. In this situation, no person could move down because all the lower rungs are full. Bohr worked out the rules for the maximum number of electrons that could be in each energy level in his model. In its normal state (ground state), this would require the atom to have all of its electrons in the lowest energy levels available. Under these circumstances, no electron could lose energy because no electron could move down to a lower energy level. In this way, the Bohr model explained why electrons circling the nucleus did not emit energy and spiral into the nucleus.

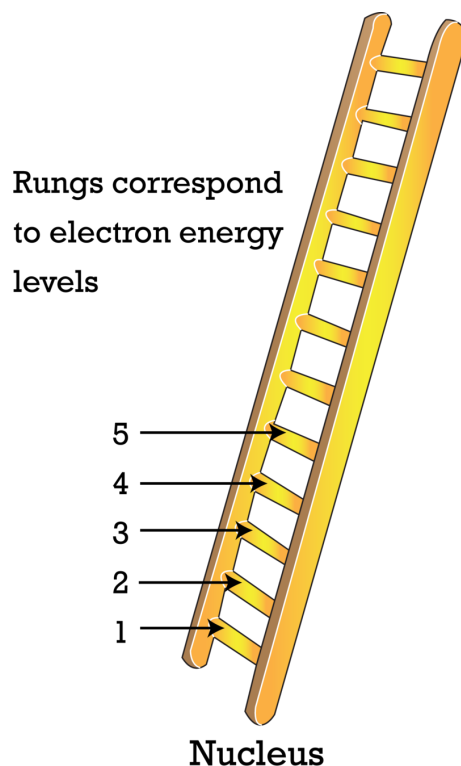

Bohr Model and Atomic Spectra

The evidence used to support the Bohr model came from the atomic spectra. Bohr suggested that an atomic spectrum is created when the electrons in an atom move between energy levels. The electrons typically have the lowest energy possible, but upon absorbing energy, the electrons would jump to a higher energy level, producing an excited and unstable state. The electrons would then immediately fall back to a lower energy level and re-emit the absorbed energy. The energy emitted during these electron “step downs” would be emitted as light and would correspond with a specific line in the atomic emission spectrum. Bohr was able to mathematically produce a set of energy levels for the hydrogen atom. In his calculations, the differences between the energy levels were the exact same energies of the frequencies of light emitted in the hydrogen spectrum. One of the most convincing aspects of the Bohr model was that it predicted that the hydrogen atom would emit some electromagnetic radiation outside the visible range. When scientists looked for these emissions in the infrared region, they were able to find them at the exact frequencies predicted by the Bohr model. Bohr’s theory was rapidly accepted and he received the Nobel Prize for physics in 1922.

Shortcomings of the Bohr Model

The development of the Bohr model is a good example of applying the scientific method. It shows how the observations of the atomic spectra led to the creation of a hypothesis about the nature of electron clouds. The hypothesis also made predictions about emissions that had not yet been observed (the infrared light emissions). Predicted observations such as these provide an opportunity to test the hypothesis through experimentation. When these predictions were found to be correct, they provided evidence in support of the theory. Of course, further observations can also provide insupportable evidence that will cause the theory to be rejected or modified. In the case of the Bohr model of the atom, it was determined that the energy levels in atoms with more than one electron could not be successfully calculated. Bohr’s system was only successful for atoms that have a single electron, which

meant that the Bohr model did not accurately reflect the behaviors of most atoms.

Another problem with Bohr's theory was that the Bohr model did not explain why certain energy levels existed. As mentioned earlier in this lesson, at the time it was already known that charged particles emit some form of light or radio waves when moving in a curved path. Scientists have used this principle to create radio signals since 1895. This was the serious flaw in Rutherford's planetary model of the atom, which Bohr attempted to deal with by suggesting his electron cloud model. Although his calculated energy levels for the hydrogen were supported by hydrogen's emission spectrum, Bohr did not, however, explain why only the exact energy levels he calculated were present.

Yet another problem with the Bohr model was the predicted positions of the electrons in the electron cloud. If Bohr's model were correct, the electron in the hydrogen atom in ground state would always be the same distance from the nucleus. Although the actual path that the electron followed could not be determined, scientists were able to determine the positions of the electron at various times. If the electron circled the nucleus as suggested by the Bohr model, the electron positions would always be the same distance from the nucleus. In reality, the electron is found at many different distances from the nucleus. In the figure below, the left side of the image (labeled as A) shows the random positions an electron would occupy as predicted by the Bohr model, while the right side (labeled as B) shows some actual positions of an electron.

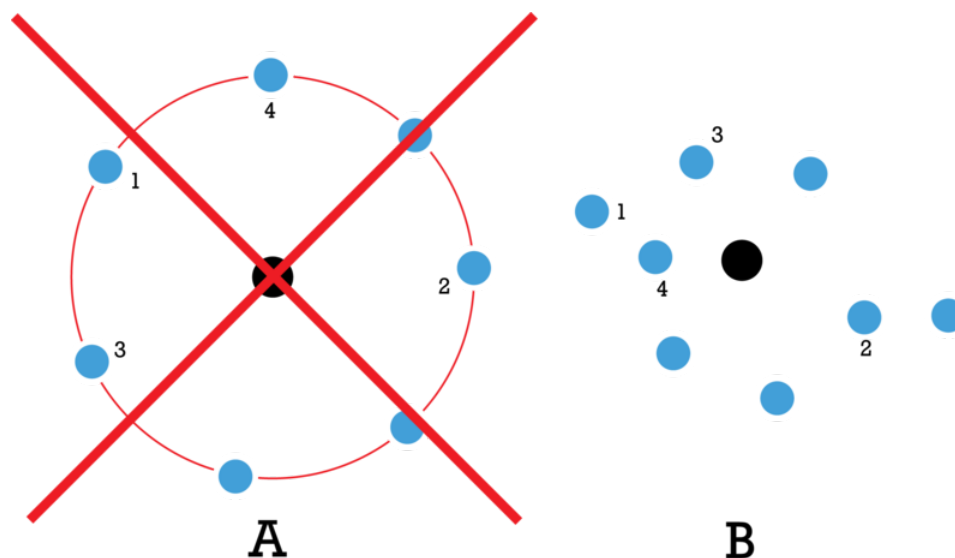

The Bohr model was not, however, a complete failure. It provided valuable insights that triggered the next step in the development of the modern concept of the atom.

Lesson Summary

- The Bohr model suggests each atom has a set of unchangeable energy levels, and electrons in the electron cloud of that atom must be in one of those energy levels.
- The Bohr model suggests that the atomic spectra of atoms is produced by electrons gaining energy from some source, jumping up to a higher energy level, then immediately dropping back to a lower energy level and emitting the energy difference between the two energy levels.
- The existence of the atomic spectra is support for the Bohr model of the atom.
- The Bohr model was only successful in calculating energy levels for the hydrogen atom.

This video provides a summary of the Bohr atomic model and how the Bohr model improved upon Rutherford's model (**1i**; **1g IE**, **1k IE**): <http://www.youtube.com/watch?v=bDUxygs7Za8> (9:08).

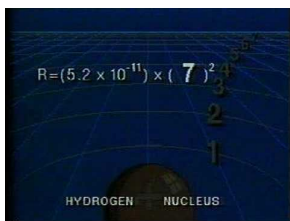
**MEDIA**

Click image to the left for more content.

This video describes the important contributions of many scientists to the modern model of the atom. It also explains Rutherford's gold foil experiment (**1g 1E**): <http://www.youtube.com/watch?v=6773jO6fMnM> (9:08).

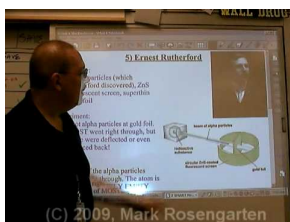
**MEDIA**

Click image to the left for more content.

Further Reading / Supplemental Links

These various videos examine the components of the Bohr model of the atom.

- <http://www.youtube.com/watch?v=QI50GBUJ48s&feature=related>
- <http://www.youtube.com/watch?v=hpKhjKrBn9s>
- <http://www.youtube.com/watch?v=-YYBCNqnYnM&feature=related>

Review Questions

1. What is the key concept in the Bohr model of the atom?
2. What is the general relationship between the amount of energy of an electron energy level and its distance from the nucleus?
3. According to Bohr's theory, how can an electron gain or lose energy?
4. What happens when an electron in an excited atom returns to its ground level?
5. What concept in Bohr's theory makes it impossible for an electron in the ground state to give up energy?
6. Use the Bohr model to explain how an atom emits a specific set of frequencies of light when it is heated or has electric current passed through it.
7. How do scientists know that the sun contains helium atoms when no one has even taken a sample of material from the sun?

All images, unless otherwise stated, are created by the CK-12 Foundation and are under the Creative Commons license CC-BY-NC-SA.

5.4 References

1. Images of neon (<http://en.wikipedia.org/wiki/File:NeTube.jpg>) and argon (<http://en.wikipedia.org/wiki/File:ArTube.jpg>) signs created by Pslawinski, created into a composite by Richard Parsons. Neon and argon gas signs. CC-BY-SA 2.5
2. . [Hydrogen Emission Spectrum](#). Public domain
3. . [Iron emission spectrum](#). Public domain
4. . [Bohr and Einstein](#). Public domain

CHAPTER

6**The Quantum Mechanical Model of the Atom****Chapter Outline**

- 6.1 THE DUAL NATURE OF LIGHT**
 - 6.2 CHARACTERISTICS OF MATTER**
 - 6.3 QUANTUM NUMBERS, ORBITALS, AND PROBABILITY PATTERNS**
-

6.1 The Dual Nature of Light

Lesson Objectives

The student will:

- name the model that replaced the Bohr model of the atom.
- explain the concept of wave-particle duality.
- solve problems involving the relationship between the frequency and the energy of a photon.

Vocabulary

- black body radiation
- diffraction
- interference
- photoelectric effect
- photon
- quantum
- quantum mechanics
- quantum theory
- wave-particle duality

Introduction

Further development in our understanding of the behavior of electrons in an atom's electron cloud required some major changes in our ideas about both matter and energy.

The branch of physics that deals with the motions of objects under the influence of forces is called mechanics. Classical mechanics refers to the laws of motion developed by Isaac Newton in the 1600s. When the Bohr model of the atom could not predict the energy levels of electrons in atoms with more than one electron, it seemed a new approach to explaining the behavior of electrons was necessary. Developed in the early 1900s, this new approach was based on the work of many scientists. The new approach came to be known as quantum mechanics (also called wave mechanics). **Quantum mechanics** is the branch of physics that deals with the behavior of matter at the atomic and subatomic level.

Properties of Waves

The controversy over the nature of light in the 1600s was partially due to the fact that different experiments with light gave different indications about the nature of light. Energy waveforms, such as water waves or sound waves,

were found to exhibit certain characteristics, including **diffraction** (the bending of waves around corners) and **interference** (the adding or subtracting of energies when waves overlap).

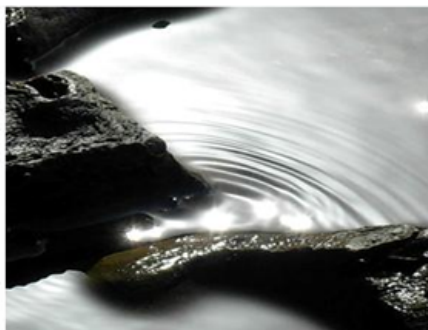
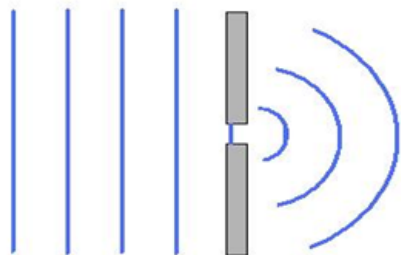

In the image above, the sketch on the left shows a series of ocean wave crests (the long straight blue lines) striking a sea wall. The sea wall has a gap between the cement barriers, which allows the water waves to pass through. The energy of the water waves passes through the gap and essentially bends around the corners so that the continuing waves are now circular and spread out on either side of the gap. The photograph on the right shows a real example of water waves diffracting through a gap between small rocks. This type of behavior is characteristic of energy waveforms.



When a body of water has more than one wave, like in the image above, the different waves will overlap and create a new wave pattern. For simplicity, we will consider a case of two water waves with the same amplitude. If the crests of both waves line up, then the new wave will have an amplitude that is twice that of the original waves. The superposition of two crests is represented in the image above as a light area. Similarly, if a trough superimposes over another trough, the new trough will be twice as deep (the darker areas in the image above). In both cases, the amplitude of the new wave is greater than the amplitudes of the individual waves.

Now imagine what would happen if the crest from one water wave is superimposed on a trough from another wave. If both waves are of equal amplitude, the upward pull of the crest and the downward pull of the trough will cancel out. In this case, the water in that area will be flat. The amplitude of this new wave is smaller than the amplitudes of the individual waves.

This process of superimposing waves that occupy the same space is called interference. When the amplitude of the new wave pattern is greater than the amplitudes of the individual waves, it is called constructive interference. When the amplitude of the new wave pattern is smaller than the amplitudes of the individual waves, it is called destructive interference. Interference behavior occurs with all energy waveforms.

Light as a Wave

Light also undergoes diffraction and interference. These characteristics of light can be demonstrated with what is called a double-slit experiment. A box is sealed on all sides so that no light can enter. On one side of the box, two very thin slits are cut. A light source placed in front of the slits will allow light to enter the two slits and shine on the back wall of the box.

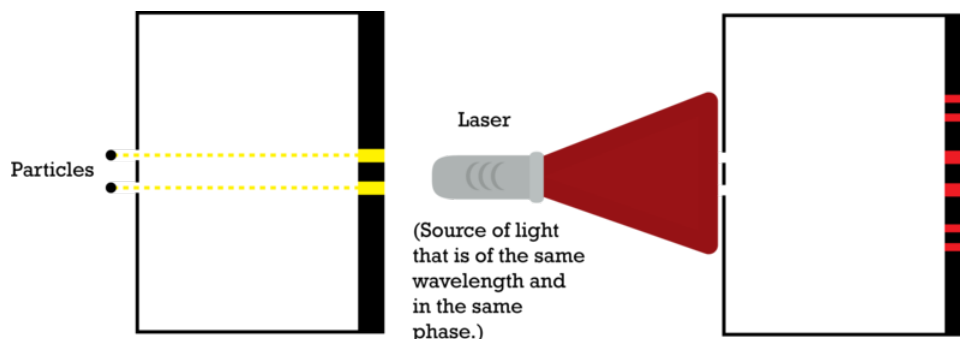

If light behaved like particles, the light would go straight from the slits to the back of the box and appear on the back wall as two bright spots (see the left side of the image above). If light behaved like waves, the waves would enter the slits and diffract. On the back wall, an interference pattern would appear with bright spots showing areas of constructive interference and dark spots showing areas of destructive interference (see the right side of the image above). When this double-slit experiment was conducted, researchers saw an interference pattern instead of two bright spots, providing reasonably conclusive evidence that light behaves like a wave.

Light as a Particle

Although the results of the double-slit experiment strongly suggested that light is a wave, a German physicist named Max Planck found experimental results that suggested light behaved more like a particle when he was studying black body radiation. A black body is a theoretical object that absorbs all light that falls on it. It reflects no radiation and appears perfectly black. **Black body radiation** is the energy that would be emitted from an ideal black body. In the year 1900, Planck published a paper on the electromagnetic radiation emitted from a black object that had been heated. In trying to explain the black body radiation, Planck determined that the experimental results could not be explained with the wave form of light. Instead, Planck described the radiation emission as discrete bundles of energy, which he called quanta. A **quantum** (singular form of quanta) is a small unit into which certain forms of energy are divided. These “discrete bundles of energy” once again raised the question of whether light was a wave or a particle – a question once thought settled by Maxwell’s work. Planck’s work also pointed out that the energy of a quantum of light was related only to its frequency. Planck’s equation for calculating the energy of a bundle of light is $E = hf$, where E is the energy of the photon in joules (J), f is the frequency in hertz (s^{-1}), and h is Planck’s constant, $6.63 \times 10^{-34} \text{ J} \cdot \text{s}$. (A **photon** is a particle of light. The word quantum is used for energy in any form; when the type of energy under discussion is light, the words quantum and photon become interchangeable.)

Example:

What is the frequency of a photon of light whose energy is 3.00×10^{-19} joules?

$$f = \frac{E}{h} = \frac{3.00 \times 10^{-19} \text{ J}}{6.63 \times 10^{-34} \text{ J} \cdot \text{s}} = 4.52 \times 10^{14} \text{ Hz}$$

Example:

What is the energy of a photon whose frequency is $2.00 \times 10^{15} \text{ s}^{-1}$?

$$E = hf = (6.63 \times 10^{-34} \text{ J} \cdot \text{s}) \cdot (2.00 \times 10^{15} \text{ s}^{-1}) = 1.33 \times 10^{-18} \text{ J}$$

Planck's work became the basis for quantum theory. **Quantum theory** is the theory that energy can only exist in discrete amounts (quanta). For example, we assume that we can cause an automobile to travel any speed we choose. Quantum theory says this is not true. The problem involved in demonstrating this theory is that the scale of a quantum of energy is much smaller than the objects we normally deal with. Imagine having a large delivery truck sitting on a scale. If we throw one more molecule onto the truck, can we expect to see the weight change on the scale? We cannot, because we lack instruments that can detect such a small change. Even if we added a thousand molecules to the truck, we still would not see a difference in the truck's weight.

For the same reason, we cannot tell that an automobile's speed is quantized (in discrete amounts). The addition of one quantum of kinetic energy to an automobile might change its velocity from 30.1111111111 miles per hour to 30.1111111122 miles per hour. Therefore, according to quantum theory, a speed of 30.1111111117 mph is *not* possible. (Note that these numbers are used for illustrative purposes only.) We are not able to detect this change because we can't measure speeds that finely. To test this theory, we must look at objects that are very tiny in order to detect a change in one quantum.

One place where we can measure quantum-sized energy changes is in the internal vibration of molecules, or the stretching and contracting of bond lengths. When the internal vibration of molecules is measured in the laboratory, it is found that the vibration motion is stair-stepped. A particular molecule may be found vibrating at 3 cycles per second 6 cycles per second or 9 cycles per second, but those molecules are *never* found vibrating at 1, 2, 4, 5, 7, or 8 cycles per second. (Again, these numbers are used for illustrative purposes only.) The fact that only certain vibration levels are available to molecules is strong support for the quantum theory.

Quantum theory can also be used to explain the result of this next experiment on light called the photoelectric effect. The **photoelectric effect** is a phenomenon in which electrons are emitted from the surface of a material after the absorption of energy. This experiment involves having light strike a metal surface with enough force to knock electrons off the metal surface. The results of the photoelectric effect indicated that if the experimenter used low frequency light, such as red, no electrons were knocked off the metal. No matter how many light waves were used and no matter how long the light was shined on the metal, red light could not knock off any electrons. If a higher frequency light was used, such as blue light, then many electrons were knocked off the metal. Albert Einstein used Planck's quantum theory to provide the explanation for the photoelectric effect. A certain amount of energy was necessary for electrons to be knocked off a metal surface. If light were quantized, then only particles of higher frequency light (and therefore higher energy) would have enough energy to remove an electron. Light particles of lower frequency (and therefore lower energy) could never remove any electrons, regardless of how many of them were used.

As a historical side note, many people may think that Einstein won the Nobel Prize for his theory of relativity, but in fact Einstein's only Nobel Prize was for his explanation of the photoelectric effect.

Wave-Particle Duality

At this point, scientists had some experimental evidence (diffraction and interference) that indicated light was a wave and other experimental evidence (black body radiation and the photoelectric effect) that indicated light was a particle. The solution to this problem was to develop a concept known as the **wave-particle duality** of light. The point of this concept is that light travels as a wave and interacts with matter like a particle. Thus when light is traveling through space, air, or other media, we speak of its wavelength and frequency, and when the light interacts with matter, we switch to the characteristics of a particle (quantum).

Lesson Summary

- The work of many scientists led to an understanding of the wave-particle duality of light.
- Light has properties of waves and particles.
- Some characteristics of energy waveforms are that they will undergo diffraction and interference.
- The energy and frequency of a light photon are related by the equation $E = hf$.

Further Reading / Supplemental Links

This website describes the double-slit experience and provides a simulation of the double-slit experiment.

- <http://www.colorado.edu/physics/2000/schroedinger/two-slit2.html>

Review Questions

1. Name a phenomenon that supports the concept that light is a wave.
2. Name a phenomenon that supports the concept that light is a packet of energy.
3. Calculate the energy in joules of a photon whose frequency is 7.55×10^{14} Hz.

6.2 Characteristics of Matter

Lesson Objectives

The student will:

- describe a standing wave.
- state the Heisenberg uncertainty principle.

Vocabulary

- Heisenberg uncertainty principle

Wave Character of Particles

In 1924, the Frenchman Louis de Broglie, a physics graduate student at the time, suggested that if waves can have particle-like properties as hypothesized by Planck, then perhaps particles can have some wave-like properties. This concept received some experimental support in 1937 when investigators demonstrated that electrons could produce diffraction patterns. (All objects, including baseballs and automobiles could be considered to have wave-like properties, but this concept is only measurable when dealing with extremely small particles like electrons.) De Broglie's "matter waves" would become very useful in attempts to describe the behavior of electrons inside atoms.

Standing Waves

In the chapter "The Bohr Model of the Atom," we considered a rope wave that was created by tying one end of the rope to a tree and by jerking the other end up and down. When a wave travels down a rope and encounters an immovable boundary, the wave reflects off the boundary and travels back up the rope. This causes interference between the wave traveling toward the tree and the reflected wave traveling back toward the person. If the person moving the rope up and down adjusts the rhythm just right, the crests and troughs of the wave moving toward the tree will coincide exactly with the crests and troughs of the reflected wave. When this occurs, the apparent horizontal motion of the crests and troughs along the rope will cease. This is called a standing wave. In such a case, the crests and troughs will remain in the exact same place, while the nodes between the crests and troughs do not appear to move at all.

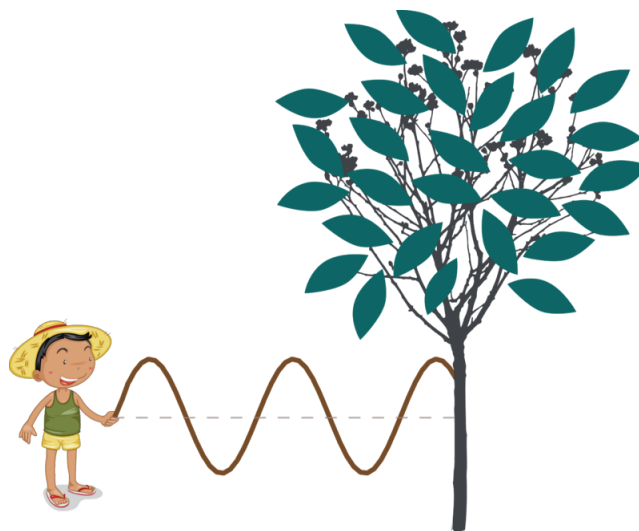

In the standing wave shown above, the positions of the crests and troughs remain in the same positions. The crests and troughs will only appear to exchange places above and below the rope. The places where the rope does not cross the center axis line are called nodes (positions of zero displacement). These nodal positions do not change and appear to be frozen in place. By combining the concept of a standing wave along with de Broglie's matter waves, it became possible to describe an electron in an electron cloud as either a particle or a standing wave.

The Heisenberg Uncertainty Principle

In all previous attempts to describe the electron's behavior inside an atom, including in the Bohr model, scientists tried to describe the path the electron would follow around the nucleus. The theorists wanted to describe where the electron was located and how it would move from that position to its next position.

In 1927, a German physicist named Werner Heisenberg, a German physicist stated what is now known as the **Heisenberg uncertainty principle**. This principle states that it is impossible to know both the precise location and the precise velocity of an electron at the same time. The reason that we can't determine both is because the act of determining the location changes the velocity. In the process of making a measurement, we have actually changed the measurement.

This problem is present in all laboratory work, but it is usually negligible. Consider the act of measuring the temperature of hot water in a beaker. When you insert the thermometer into the water, the water transfers heat to the thermometer until the thermometer is at the same temperature as the water. You can then read the temperature of the water from the thermometer. The temperature of the water, however, is no longer the same as before you inserted the thermometer. The water has cooled by transferring some of its heat to the thermometer. In other words, the act of making the measurement changes the measurement. In this example, the difference is most likely not significant. You can imagine, however, that if the mass of water was very small and the thermometer was very large, the water would have to transfer a greater amount of heat to the thermometer, resulting in a less accurate measurement.

Consider the method that humans use to see objects. We see an object when photons bounce off the object and into our eye or other light-measuring instrument. Recall that photons can have various wavelengths, which correspond to different colors. If only red photons bounce back, we say the object is red. If no photons bounce back, we don't see the object. Suppose for a moment that humans were gigantic stone creatures that use golf balls, instead of photons, to see. In other words, we see objects when the golf balls bounce off them and enter our eyes. We would be able to see large objects like buildings and mountains successfully, because the golf balls would bounce off and reach our eyes. Could we see something small like a butterfly with this technique? The answer is no. A golf ball has a greater mass than a butterfly, so when the golf ball bounces off the butterfly, the motion of the butterfly will be very different

after the collision. We will know the position of the butterfly, but we won't know the motion of the butterfly.

In the case of electrons, the photons we use to see them with are of significant energy compared to electrons and will change the motion of the electrons upon collision. We may be able to detect the position of the electron, but its motion is no longer the same as before the observation. The Heisenberg uncertainty principle tells us we cannot be sure of both the location and the motion of an electron at the same time. As a result, we must give up on the idea of determining the path an electron follows inside an atom.

Schrödinger's Equation

The Heisenberg uncertainty principle treated the electron as a particle. In effect, the uncertainty principle stated that the exact motion of an electron in an atom could never be determined, which also meant that the exact structure of the atom could not be determined. Consequently, Erwin Schrödinger, an Austrian physicist, decided to treat the electron as a wave in accordance with de Broglie's matter waves.

Schrödinger, in considering the electron as a wave, developed an equation to describe the electron wave behavior in three dimensions (shown below). Unfortunately, the equation is so complex that it is actually *impossible* to solve exactly for atoms and ions that contain more than one electron. High-speed computers, however, can produce very, very close approximations, and these "solutions" have provided a great deal of information about the possible organization of electrons within an electron cloud.

$$\frac{\partial^2 \psi}{\partial x^2} + \frac{8\pi^2 m}{h^2} (E - V)\psi = 0$$

Labels in the diagram:
 - Second derivative with respect to x (points to $\partial^2 \psi$)
 - Schrodinger Wave Function (points to ψ)
 - Position (points to x)
 - Energy (points to E)
 - Potential Energy (points to V)

When we represent electrons inside an atom, quantum mechanics requires that the wave must "fit" inside the atom so that the wave meets itself with no overlap. In other words, the "electron wave" inside the atom must be a standing wave. If the wave is to be arranged in the form of a circle so that it attaches to itself, the waves can only occur if there is a whole number of waves in the circle. Consider the image below.

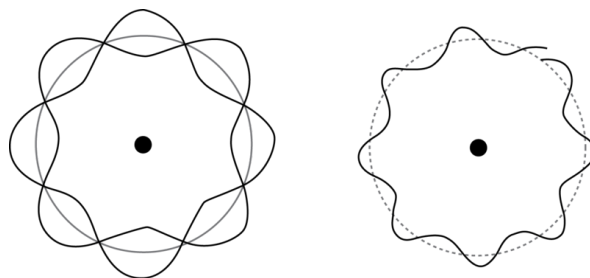

On the left is an example of a standing wave. For the wave on the right, the two ends of the wave do not quite meet each other, so the wave fails to be a standing wave. There are only certain energies (frequencies) for which the wavelength of the wave will fit exactly to form a standing wave. These energies turn out to be the same as the energy levels predicted by the Bohr model, but now there is a reason why electrons may only occupy these energy

levels. (Recall that one of the problems with the Bohr model was that Bohr had no explanation for why the electrons could only occupy certain energy levels in the electron cloud.) The equations of quantum mechanics tell us about the existence of principal energy levels, the number of energy levels in any atom, and more detailed information about the various energy levels.

Lesson Summary

- The Heisenberg uncertainty principle states that it is impossible to know both the precise location and the precise motion of an electron at the same time.
- Electrons in an electron cloud can be viewed as a standing wave.
- The reason that an electron in an atom may have only certain energy levels is because only certain energies of electrons will form standing waves in the enclosed volume.
- The solutions to Schrödinger's equation provide a great deal of information about the organization of the electrons in the electron cloud.

Further Reading / Supplemental Links

A question and answer session on electrons behaving as waves.

- <http://www.colorado.edu/physics/2000/quantumzone/debroglie.html>

Review Questions

1. Which of the following statements are true?
 - a. According to the Heisenberg uncertainty principle, we will eventually be able to measure both an electron's exact position and its exact momentum at the same time.
 - b. The problem that we have when we try to measure an electron's exact position and its exact momentum at the same time is that our measuring equipment is not good enough.
 - c. According to the Heisenberg uncertainty principle, we cannot know both the exact location and the exact momentum of an automobile at the same time.
 - d. The Heisenberg uncertainty principle applies only to very small objects like protons and electrons.
 - e. The Heisenberg uncertainty principle applies only to large objects like cars and airplanes.
 - f. The Heisenberg Heisenberg uncertainty principle applies to very small objects like protons and electrons and to large objects like cars and airplanes.

6.3 Quantum Numbers, Orbitals, and Probability Patterns

Lesson Objectives

The student will:

- state the relationship between the principal quantum number (n), the number of orbitals, and the maximum number of electrons in a principal energy level.

Vocabulary

- Pauli exclusion principle
- principal quantum number
- quantum number

Introduction

Erwin Schrödinger proposed a wave equation for electron matter waves that was similar to the known equations for other wave motions in nature. This equation describes how a wave associated with an electron varies in space as the electron moves under various forces. Schrödinger worked out the solutions of his equation for the hydrogen atom, and the results agreed perfectly with the known energy levels for hydrogen. Furthermore, the equation could be applied to more complicated atoms. It was found that Schrodinger's equation gave a correct description of an electron's behavior in almost every case. In spite of the overwhelming success of the wave equation in describing electron energies, the very meaning of the waves was vague and unclear.

There are very few scientists who can visualize the behavior of an electron as a standing wave during chemical bonding or chemical reactions. When chemists are asked to describe the behavior of an electron in an electrochemical cell, they do not use the mathematical equations of quantum mechanics, nor do they discuss standing waves. The behavior of electrons in chemical reactions is best understood by considering the electrons to be particles.

A physicist named Max Born was able to attach some physical significance to the mathematics of quantum mechanics. Born used data from Schrodinger's equation to show the probability of finding the electron (as a particle) at the point in space for which the equation was solved. Born's ideas allowed chemists to visualize the results of Schrodinger's wave equation as probability patterns for electron positions.

Probability Patterns

Suppose we had a camera with such a fast shutter speed that it could capture the position of an electron at any given moment. We could take a thousand pictures of this electron at different times and find it at many different positions in the atom. We could then plot all the electron positions onto one picture, as seen in the sketch below.

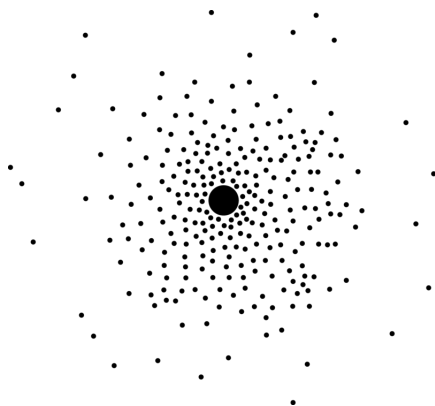

One way of looking at this picture is as an indication of the probability of where you are likely to find the electron in this atom. Keep in mind that this image represents an atom with a single electron. The dots do not represent different electrons; the dots are positions where the single electron can be found at different times. From this image, it is clear that the electron spends more time near the nucleus than it does far away. As you move away from the nucleus, the probability of finding the electron becomes less and less. It is important to note that there is no boundary in this picture. In other words, there is no distance from the nucleus where the probability of finding an electron becomes zero. However, for much of the work we will be doing with atoms, it is convenient (even necessary) to have a boundary for the atom. Most often, chemists arbitrarily draw in a boundary for the atom, choosing some distance from the nucleus beyond which the probability of finding the electron becomes very low. Frequently, the boundary is placed such that 90% of the probability of finding the electron is inside the boundary.

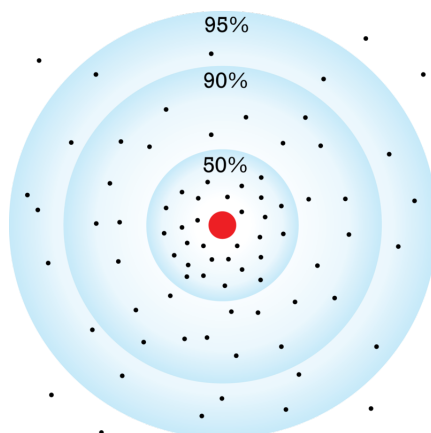

The image above shows boundaries drawn in at 50%, 90%, and 95% probability of finding the electron within the boundary. It is important to remember that the boundary is there for our convenience, and there is no actual boundary on an atom. This probability plot is very simple because it is for the first electron in an atom. As the atoms become more complicated (more energy levels and more electrons), the probability plots also become more complicated.

All of the scientists whose names appear in the "Atom Song" have appeared in our book. Please watch the video: <http://www.youtube.com/watch?v=vUzTQWn-wfE> (3:28).

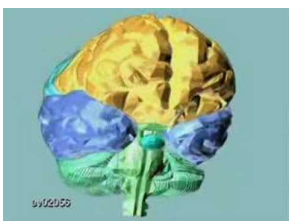

MEDIA

Click image to the left for more content.

The Principal Quantum Number

Solutions to Schrödinger's equation involve four special numbers called **quantum numbers**. (Three of the numbers come from Schrödinger's equation, and the fourth one comes from an extension of the theory.) These four numbers completely describe the energy of an electron. Each electron has exactly four quantum numbers, and no two electrons have the same four numbers. The statement that no two electrons can have the same four quantum numbers is known as the **Pauli exclusion principle**.

The **principal quantum number** is a positive integer (1, 2, 3, . . . n) that indicates the main energy level of an electron within an atom. According to quantum mechanics, every principal energy level has one or more sub-levels within it. The number of sub-levels in a given energy level is equal to the number assigned to that energy level. That is, principal energy level 1 will have 1 sub-level, principal energy level 2 will have two sub-levels, principal energy level 3 will have three sub-levels, and so on. In any energy level, the maximum number of electrons possible is $2n^2$. Therefore, the maximum number of electrons that can occupy the first energy level is 2 ($2 \cdot 1^2$). For energy level 2, the maximum number of electrons is 8 ($2 \cdot 2^2$), and for the 3rd energy level, the maximum number of electrons is 18 ($2 \cdot 3^2$). **Table 6.1** lists the number of sub-levels and electrons for the first four principal quantum numbers.

TABLE 6.1: Number of Sub-levels and Electrons by Principal Quantum Number

Principal Quantum Number	Number of Sub-Levels	Total Number of Electrons
1	1	2
2	2	8
3	3	18
4	4	32

The largest known atom contains slightly more than 100 electrons. Quantum mechanics sets no limit as to how many energy levels exist, but no more than 7 principal energy levels are needed to describe the electrons of all known atoms. Each energy level can have as many sub-levels as the principal quantum number, as discussed above, and each sub-level is identified by a letter. Beginning with the lowest energy sub-level, the sub-levels are identified by the letters *s*, *p*, *d*, *f*, *g*, *h*, *i*, and so on. Every energy level will have an *s* sub-level, but only energy levels 2 and above will have *p* sub-levels. Similarly, *d* sub-levels occur in energy level 3 and above, and *f* sub-levels occur in energy level 4 and above. Energy level 5 could have a fifth sub-energy level named *g*, but all the known atoms can have their electrons described without ever using the *g* sub-level. Therefore, we often say there are only four sub-energy levels, although theoretically there can be more than four sub-levels. The principal energy levels and sub-levels are shown in the following diagram. The principal energy levels and sub-levels that we use to describe electrons are in red.

Energy Levels	Sub-Levels									
1	s									
2	s	p								
3	s	p	d							
4	s	p	d	f						
5	s	p	d	f	g					
6	s	p	d	f	g	h				
7	s	p	d	f	g	h	i			
8	s	p	d	f	g	h	i	j		

Orbitals

Quantum mechanics also tells us how many orbitals are in each sub-level. In Bohr's model, an orbit was a circular path that the electron followed around the nucleus. In quantum mechanics, an orbital is defined as an area in the electron cloud where the probability of finding the electron is high. The number of orbitals in an energy level is equal to the square of the principal quantum number. Hence, energy level 1 will have 1 orbital (1^2), energy level 2 will have 4 orbitals (2^2), energy level 3 will have 9 orbitals (3^2), and energy level 4 will have 16 orbitals (4^2).

The *s* sub-level has only one orbital. Each of the *p* sub-levels has three orbitals. The *d* sub-levels have five orbitals, and the *f* sub-levels have seven orbitals. If we wished to assign the number of orbitals to the unused sub-levels, *g* would have nine orbitals and *h* would have eleven. You might note that the number of orbitals in the sub-levels increases by odd numbers (1, 3, 5, 7, 9, 11, . . .).

As a result, the single orbital in energy level 1 is the *s* orbital. The four orbitals in energy level 2 are a single $2s$ orbital and three $2p$ orbitals. The nine orbitals in energy level 3 are a single $3s$ orbital, three $3p$ orbitals, and five $3d$ orbitals. The sixteen orbitals in energy level 4 are a the single $4s$ orbital, three $4p$ orbitals, five $4d$ orbitals, and seven $4f$ orbitals.

Principal Energy Level (<i>n</i>)	Number of Orbitals Present				Total Number of Orbitals (n^2)	Maximum Number of Electrons ($2n^2$)
	<i>s</i>	<i>p</i>	<i>d</i>	<i>f</i>		
1	1	-	-	-	1	2
2	1	3	-	-	4	8
3	1	3	5	-	9	18
4	1	3	5	7	16	32

The chart above shows the relationship between *n* (the principal quantum number), the number of orbitals, and the maximum number of electrons in a principal energy level. Theoretically, the number of orbitals and number of electrons continue to increase for higher values of *n*. However, no atom actually has more than 32 electron in any of its principal levels.

Each orbital will also have a probability pattern that is determined by interpreting Schrödinger's equation. Earlier, we showed that the probability pattern for an atom with a single electron is a circle. The illustration, however, is 2-dimensional. The real 3-dimensional probability pattern for the single orbital in the s sub-level is actually a sphere.

The probability patterns for the three orbitals in the p sub-levels are shown below. The three images on the left show the probability pattern for the three p orbitals in each of the three dimensions. On the far right is an image of all three p orbitals together. These p orbitals are said to be shaped like dumbbells (named after the objects weight lifters use), water wings (named after the floating balloons young children use in the swimming pool), and various other objects.

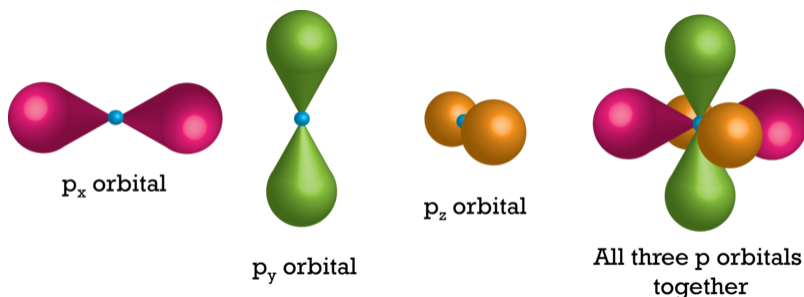

The probability patterns for the five d orbitals are more complicated and are shown below.

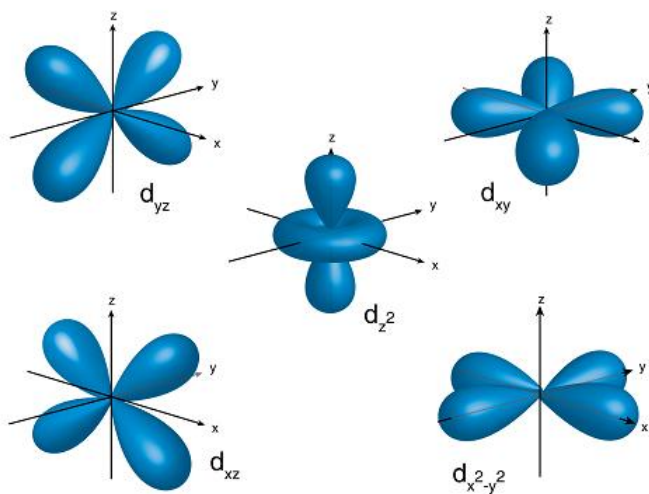

The seven f orbitals shown below are even more complicated.

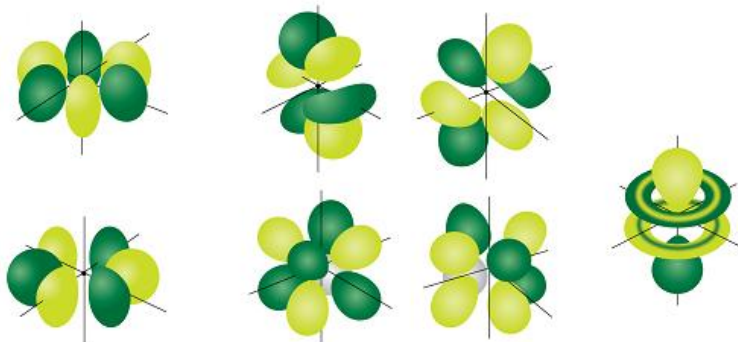

You should keep in mind that no matter how complicated the probability pattern is, each shape represents a single orbital, and the entire probability pattern is the result of the various positions that either one or two electrons can take.

A video discussing the relationship between spectral lines and electron transitions is available at (1j) <http://www.youtube.com/watch?v=fKYso97eJs4> (3:49).

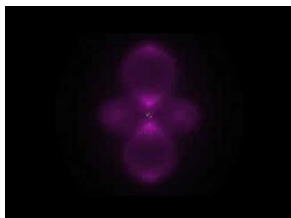

MEDIA

Click image to the left for more content.

A short animation of s and p orbitals is available on youtube.com at <http://www.youtube.com/watch?v=VfBcfYR1VQo> (1:20).

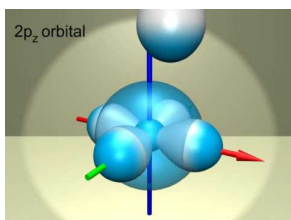

MEDIA

Click image to the left for more content.

Another example of s, p and d electron orbitals is available also on youtube.com at <http://www.youtube.com/watch?v=K-jNgq16jEY> (1:37).

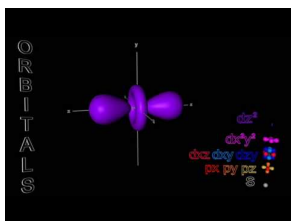

MEDIA

Click image to the left for more content.

Lesson Summary

- Solutions to Schrodinger's equation involve four special numbers called quantum numbers, which completely describe the energy of an electron.
- Each electron has exactly four quantum numbers.
- According to the Pauli Exclusion Principle, no two electrons have the same four quantum numbers.
- The major energy levels are numbered by positive integers (1, 2, 3, . . . , n), and this number is called the principal quantum number
- Quantum mechanics also tells us how many orbitals are in each sub-level.
- In quantum mechanics, an orbital is defined as an area in the electron cloud where the probability of finding the electron is high.

Further Reading / Supplemental Links

The following is a video on the quantum mechanical model of the atom.

- http://www.youtube.com/watch?v=IsA_oIXdF_8&feature=related

This video is a ChemStudy film called “Hydrogen Atom and Quantum Mechanics.” The film is somewhat dated but the information is accurate. The video also contains some data supporting quantum theory.

- <http://www.youtube.com/watch?v=80ZPe80fM9U>

Review Questions

1. How many sub-levels may be present in principal energy level 3 ($n = 3$)?
2. How many sub-levels may be present in principal energy level 6 ($n = 6$)?
3. Describe the difference in the definitions of a Bohr orbital and a quantum mechanics orbital.
4. What is the maximum total number of electrons that can be present in an atom having three principal energy levels?

In the first image of this chapter, the photograph showing water waves diffracting through a gap between small rocks is from <http://www.flickr.com/photos/framesofmind/554402976/> (CC-BY-SA).

All images, unless otherwise stated, are created by the CK-12 Foundation and are under the Creative Commons license CC-BY-NC-SA.

CHAPTER

7

The Electron Configuration of Atoms

Chapter Outline

7.1 ELECTRON ARRANGEMENT

7.2 VALENCE ELECTRONS

7.1 Electron Arrangement

Lesson Objectives

The student will:

- draw the orbital representation for selected atoms.
- write the electron configuration code for selected atoms.
- identify the principal, angular momentum, magnetic, and spin quantum numbers.
- identify the four quantum numbers for indicated electrons.
- identify the energy level, sub-energy level, orbital, and spin for an electron given the four quantum numbers for the electron

Vocabulary

- angular momentum quantum number
- Aufbau principle
- electron configuration code
- Hund's rule
- magnetic quantum number
- orbital representation
- spin quantum number

Introduction

When dealing with the chemical behavior of atoms, it is not feasible to consider electrons as standing waves, nor is it feasible to indicate the positions of electrons in the electron cloud by drawing probability patterns. Fortunately, chemists have developed simpler and faster methods of describing the ways that electrons are arranged within atoms. It is important to be familiar with all of these methods, because the most useful way to represent the electron distribution often depends on the particular situation.

The Orbital Representation

The **orbital representation** uses circles or lines to represent each orbital. In the figure below, all the energy levels, sub-levels, and orbitals are represented through $7p$. The distance from the bottom of the chart indicates the energy of each energy level and sub-level. The closer the energy level is to the bottom of the chart, the lower its energy. At the bottom of the chart, you will find the first energy level, $n = 1$. The chart shows only one circle in the first energy level. This is because the first energy level contains only one s sub-level, and s sub-levels have only one orbital.

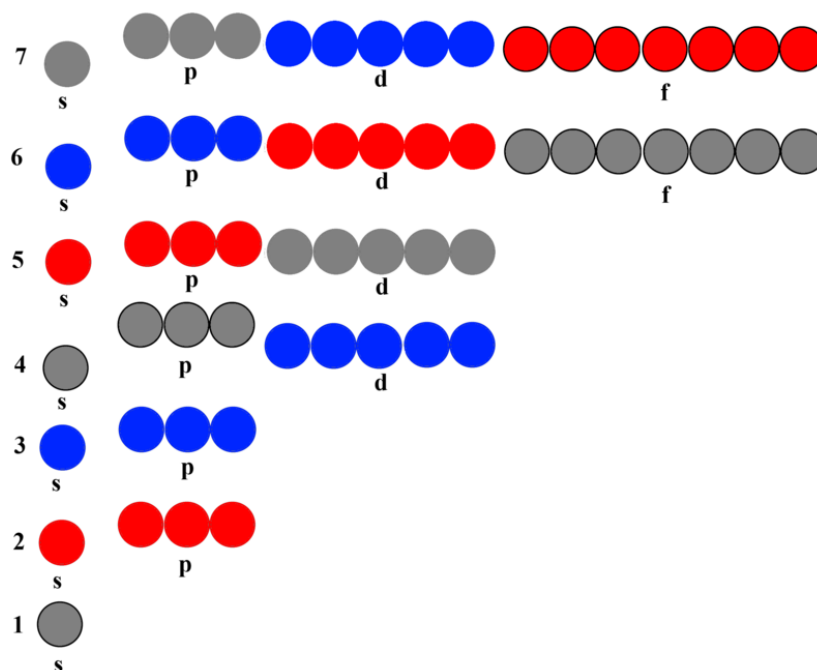

Proceeding up the chart (higher energy), we see the second energy level, $n = 2$. The second energy level has both an s sub-level and a p sub-level. The s sub-level in the second energy level, like all s sub-levels, contains only one orbital and is represented by a single circle. The second energy level also has a p sub-level, which consists of three orbitals. The three orbitals in a p sub-level all have the same energy. Therefore, the p sub-level is represented by three circles equidistant from the bottom of the chart. This process is continued through the first seven energy levels and each of the sub-levels.

Careful observation of the orbital representation chart will show that the next higher energy sub-level is not always what you might expect. If you look closely at the relationship between the $3d$ and $4s$ sub-levels, you will notice that the $4s$ sub-level is slightly lower in energy than the $3d$ sub-level. Therefore, when the energy sub-levels are being filled with electrons, the $4s$ orbital is filled before the $3d$ orbitals. As you go up the chart, there are more of these variations. The complete filling order is given in the chart below.

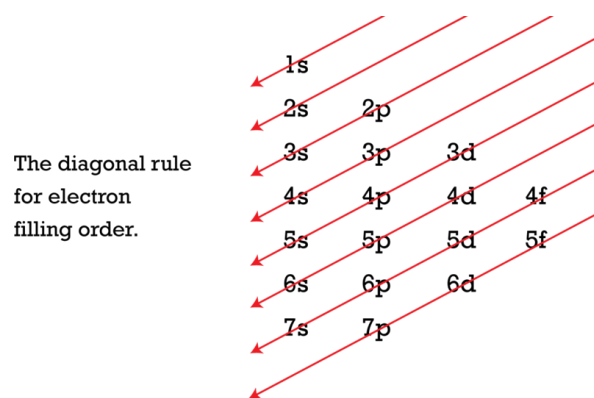

Filling order: $1s, 2s, 2p, 3s, 3p, 4s, 3d, 4p, 5s, 4d, 5p, 6s, 4f, 5d, 6p, 7s, 5f, 6d, 7p$

To determine the filling order, follow the top arrow from the base to the arrowhead. When you reach the arrowhead, move to the base of the next arrow and follow it to the arrowhead.

This process of building up the atoms by adding one proton to the nucleus and one electron to the electron cloud is known as the Aufbau principle. The **Aufbau principle** states that as electrons are added to “build up” the elements, each electron is placed in the lowest energy orbital available. (*Aufbau* is German for “building up”.)

Rules for Determining Electron Configuration:

1. Following the Aufbau principle, each added electron enters the lowest energy orbital available.
2. No more than two electrons can be placed in any orbital.
3. Before a second electron can be placed in any orbital, all the orbitals of that sub-level must contain at least one electron. This is known as **Hund's Rule**.

Here is the orbital representation for the electron configuration of carbon:

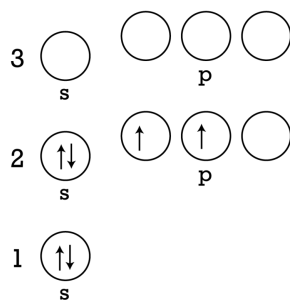

A carbon atom has six protons and six electrons. When placing the electrons in the appropriate orbitals, the first two electrons go into the 1s orbital, the second two go into the 2s orbital, and the last two go into 2p orbitals. Since electrons repel each other, the electrons in the 2p orbitals go into separate orbitals before pairing up. Hund's rule is a statement of this principle, stating that no electrons are paired in a given orbital until all the orbitals of the same sub-level have received at least one electron. If you look at the orbital representation for the electron configuration of oxygen, shown below, you will see that all three 2p orbitals have at least one electron and only one 2p orbital has two electrons.

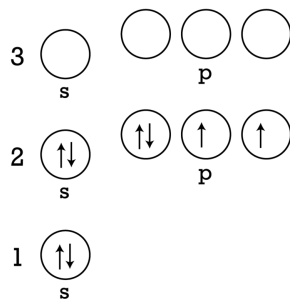



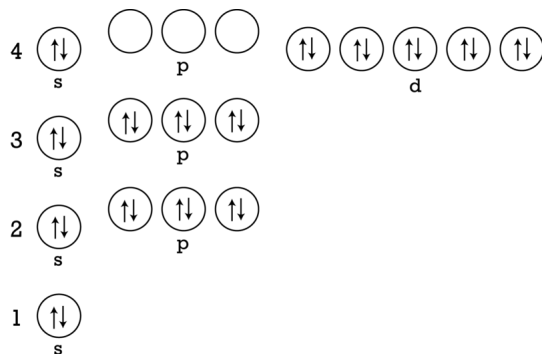









The image below shows an example of the orbital representation for zinc.

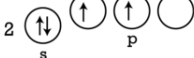

The Electron Configuration Code

A shorthand method for representing the electron arrangement in the orbital representation is called the electron configuration code. The **electron configuration code** lists the number of the principal energy level followed by the letter of the sub-level type. A superscript is placed on the sub-level letter to indicate the number of electrons in that sub-level. For example, we looked at the orbital representation of carbon in the previous section. The electron configuration code for that configuration is $1s^22s^22p^2$. This code shows that the $1s$ sub-level holds two electrons, the $2s$ sub-level holds two electrons, and the $2p$ sub-level holds two electrons. The electron configuration is $1s^22s^22p^4$ for oxygen and $1s^22s^22p^63s^23p^64s^23d^{10}$ for zinc. The electron configuration code follows the same filling order as the orbital representation, so the $4s$ orbital comes before the $3d$ orbital.

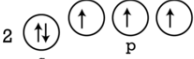
The chart below shows the electron configuration code and the orbital representation for the first seven elements in the periodic table.

Element Symbol	Electron Configuration Code	Orbital Representation
H	$1s^1$	1 
He	$1s^2$	1 
Li	$1s^22s^1$	2  1 
Be	$1s^22s^2$	2  1 
B	$1s^22s^22p^1$	2  1 
C	$1s^22s^22p^2$	2  1 
N	$1s^22s^22p^3$	2  1 

As the electron configurations get longer and longer, it becomes tedious to write them out. A shortcut has been devised to make this process less tedious. Consider the electron configuration for potassium: $1s^22s^22p^63s^23p^64s^1$. The electron configuration for argon is similar, except that it has one less electron than potassium: $1s^22s^22p^63s^23p^6$. It is acceptable to use $[\text{Ar}]$ to represent the electron configuration for argon and $[\text{Ar}]4s^1$ to represent the code for potassium. Using this shortcut, the electron configuration for calcium would be $[\text{Ar}]4s^2$, and the code for scandium

would be $[\text{Ar}]4s^23d^1$. Note that generally only noble gases (the last column on the periodic table) have their electron configurations abbreviated in this form. For example, aluminum would rarely (if ever) be represented as $[\text{Na}]3p^1$. Instead, the electron configuration would be written as $[\text{Ne}]3s^23p^1$.

Quantum Numbers

Recall from the chapter on “The Quantum Mechanical Model of the Atom” that there are four quantum numbers coming from the solutions and extension to Schrödinger’s equation. These numbers have a precise correspondence to the orbital representation discussed in the previous section. The principal quantum number, n , is the number of the energy level and is sometimes referred to as the electron shell. This number may be any non-zero positive integer (1, 2, 3, . . .). Although there is no theoretical maximum principal quantum number, in practice we will not need a number greater than 7.

The second quantum number is called the **angular momentum quantum number** and is designated by the script letter ℓ . The angular momentum quantum number describes the sub-shell or region in which the electron can be found. This quantum number dictates orbital space and may have any integer value from 0 to $n - 1$. Therefore, if $n = 1$, ℓ may only have the value 0. Possible ℓ values for the first four energy levels are shown in **Table 7.1**. The ℓ quantum number corresponds to the sub-energy levels in our orbital representation. The s sub-level is represented by $\ell = 0$, the p sub-level by $\ell = 1$, the d sub-level by $\ell = 2$, and the f sub-level by $\ell = 3$. Theoretically, there are more sub-levels, but these four are enough to describe the ground state of all known elements.

TABLE 7.1: The First Two Quantum Numbers

n value	Possible ℓ values	Sub-energy level
1	0	0 = s
2	0, 1	0 = s , 1 = p
3	0, 1, 2	0 = s , 1 = p , 2 = d
4	0, 1, 2, 3	0 = s , 1 = p , 2 = d , 3 = f

Therefore, the first two quantum numbers for an electron tell us what energy level and what sub-level the electron occupies.

The third quantum number is called the **magnetic quantum number** and is designated by the letter m or m_ℓ . The magnetic quantum number may have integer values from ℓ to $-\ell$, as seen in **Table 7.2**. This quantum number describes the orientation of a particular orbital in space.

TABLE 7.2: The Third Quantum Number

ℓ value	Possible m_ℓ values
$\ell = 0$	$m_\ell = 0$
$\ell = 1$	$m_\ell = -1, 0, +1$
$\ell = 2$	$m_\ell = -2, -1, 0, +1, +2$
$\ell = 3$	$m_\ell = -3, -2, -1, 0, +1, +2, +3$

The m_ℓ quantum number corresponds to the individual orbitals within a sub-energy level. When $\ell = 0$, the sub-energy level is s . Since sub-level s has only one orbital, $m = 0$ refers to that single orbital. When $\ell = 1$, the sub-energy level is p , which has three orbitals. Each of the m numbers (-1, 0, +1) refer to one of the p orbitals. Similarly, the five possible m_ℓ values for $\ell = 2$ correspond to the five possible d orbitals, and the seven possible values for $\ell = 3$ correspond to the seven f orbitals.

The final quantum number is called the **spin quantum number** and is designated by the letter s (not to be confused

with the s sub-level, it is sometimes denoted m_s in other sources). The only possible values for s are either $+\frac{1}{2}$ or $-\frac{1}{2}$. Electron “spin” is a property that is not encountered in the macroscopic world, but it has characteristics that are similar to the angular momentum of a charged, spinning sphere. In order for two electrons to occupy the same orbital, they must have different spin values. The first three quantum numbers are specified by the orbital, so adding two electrons with the same spin would violate the Pauli Exclusion Principle.

A complete set of four quantum numbers will identify any individual electron in the atom. For example, suppose we have the quantum numbers 2, 1, 1, $+\frac{1}{2}$ for an electron. This electron will be in the second energy level, the p sub-level, the +1 orbital, and it will be spinning in the $+\frac{1}{2}$ direction. This set of four numbers specifically identifies one particular electron in the electron cloud, so no other electron may have the same combination of numbers.

Example:

Give four possible quantum numbers for the electron indicated in the orbital representation shown below.

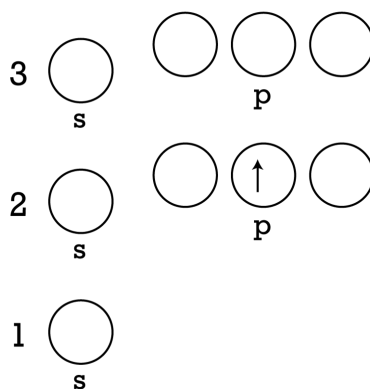

The electron is in the second energy level, hence $n = 2$. It is in the p sub-energy level, so we can let $\ell = 1$. It is in the middle orbital, which we can assign as $m = 0$. It is pointing up, which we can assign as $s = +\frac{1}{2}$.

We should take a moment to recognize that the three orbitals in the p sub-levels are sometimes designated as the p_x , p_y , and p_z orbitals. This designation points out that the spatial orientation of the three orbitals corresponds to the three dimensions in a three-dimensional coordinate system. Since an atom can be rotated through any angle, designating a specific orbital to be called p_x , p_y , or p_z becomes pointless. As long as we recognize there are three mutually perpendicular orbitals, it doesn't make any difference which one is called p_x . This same reasoning applies to assigning $+\frac{1}{2}$ and $-\frac{1}{2}$ to the s quantum numbers. We must recognize that two electrons may occupy the same orbital and must have a different s quantum value, but which electron is assigned to be $+\frac{1}{2}$ and which one to be $-\frac{1}{2}$ makes no difference.

This video discusses the physical interpretation of quantum numbers (**1g**): <http://www.youtube.com/watch?v=e9N2h8c6dE4> (6:22).

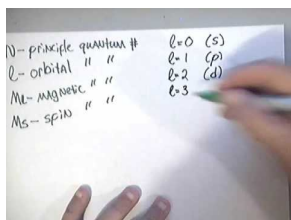

MEDIA

Click image to the left for more content.

The other video explains the four quantum numbers which give the "address" for an electron in an atom (**1g**): <http://www.youtube.com/watch?v=63u7A2NIiyU> (2:54).

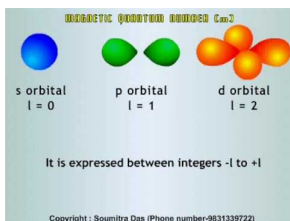
**MEDIA**

Click image to the left for more content.

Lesson Summary

- The orbital representation uses circles or lines to represent each atomic orbital.
- In the orbital representation, the distance from the bottom of the chart indicates the energy of each energy level and sub-level.
- The Aufbau principle states that as electrons are added to “build up” the elements, each electron is placed in the lowest energy orbital available.
- Hund’s rule states that no electrons are paired in a given orbital until all the orbitals of the same sub-level have received at least one electron.
- A shorthand method of representing electron arrangement is called the electron configuration code.
- The electron configuration code lists the number of the principal energy level followed by the letter of the sub-level type. A superscript is placed on the sub-level letter to indicate the number of electrons in that sub-level.
- A set of four quantum numbers specifically identifies one particular electron in the electron cloud, and no two electrons may have the same four quantum numbers.
- The principal quantum number is the number of the energy level.
- The second quantum number is called the angular momentum quantum number. This number indicates the subshell in which an electron can be found.
- The third quantum number is called the magnetic quantum number and describes the orientation in space of a particular orbital.
- The final quantum number is called the spin quantum number and indicates the orientation of the angular momentum of an electron in an atom.

Further Reading / Supplemental Links

These two websites examine the discovery of the spin quantum number.

- <http://www.lorentz.leidenuniv.nl/history/spin/goudsmit.html>
- http://www.ethbib.ethz.ch/exhibit/pauli/elektronenspin_e.html

This video provides an introduction to the electron configuration of atoms.

- <http://www.youtube.com/watch?v=fv-YeI4hcQ4>

Review Questions

1. How many energy levels are used for known atoms?
2. Which principal energy level holds a maximum of eight electrons?

3. Which sub-energy level holds a maximum of six electrons?
4. Which sub-energy level holds a maximum of ten electrons?
5. Compare the energy of an electron in the $3d$ sub-level to that of an electron in the $4s$ sub-level of the same atom. Which one is greater in energy?
6. When the $3p$ sub-level of an energy level is filled, where does the next electron go?
7. If all the orbitals in the first two principal energy levels are filled, how many electrons are required?
8. How many electrons are in the electron cloud of a neutral carbon atom?
9. In which principal energy level and sub-level of the carbon atom is the outermost electron located?
10. How many electrons are in the $2p$ sub-energy level of a neutral nitrogen atom?
11. Which element's neutral atoms will have the electron configuration $1s^2 2s^2 2p^6 3s^2 3p^1$?
12. What energy level and sub-level immediately follow $5s$ in the filling order?
13. When the $4f$ and all lower sub-energy levels are filled, what is the total number of electrons in the electron cloud?
14. What is the outermost energy level and sub-level used in the electron configuration of potassium?
15. How many electrons are present in the $2p$ orbitals of a neutral fluorine atom?
16. Which element will have the electron configuration code $1s^2 2s^2 2p^6 3s^2 3p^2$?
17. Write the electron configuration code for chlorine.
18. In an atom, what is the maximum number of electrons that can have the principal quantum number $n = 3$?
19. In an atom, what is the maximum number of electrons that can have the quantum numbers $n = 3, \ell = 2$?
20. In an atom, what is the maximum number of electrons that can have the quantum numbers $n = 3, \ell = 2, m_\ell = 0$?
21. The following set of quantum numbers is not possible: $n = 1, \ell = 1, m_\ell = 0$. Explain why not.
22. The following set of quantum numbers is not possible: $n = 2, \ell = -1, m_\ell = 0$. Explain why not.

7.2 Valence Electrons

Lesson Objectives

The student will:

- define valence electrons.
- indicate the number of valence electrons for selected atoms.
- draw Lewis dot diagrams for selected atoms.

Vocabulary

- core electron
- Lewis dot diagram
- valence electron
- valence shell

Introduction

The electrons in the outermost shell are the **valence electrons**. These are the electrons in an atom that can participate in a chemical reaction. Since filled *d* or *f* subshells are seldom disturbed in a chemical reaction, we can define valence electrons as follows: The electrons in an atom that are not present in the previous noble gas (elements in the last column of the periodic table), ignoring filled *d* or *f* subshells.

Gallium has the following electron configuration:

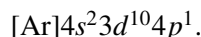

The *4s* and *4p* electrons can be lost in a chemical reaction, but the electrons in the filled *3d* subshell cannot. Gallium therefore has three valence electrons.

Determining Valence Electrons

Valence electrons are the electrons in the outermost principal quantum level of an atom. Sometimes, the outermost energy level is called the **valence shell**. The electrons that are not in the outermost energy level are known as **core electrons**. The number of valence electrons for an atom can be seen in either the orbital representation or the electron configuration. The electron configuration for magnesium is $1s^22s^22p^63s^2$. The outer energy level for this atom is $n = 3$, and it has two electrons in this energy level. Therefore, magnesium has two valence electrons. The electron configuration for sulfur is $1s^22s^22p^63s^23p^4$. The outer energy level in this atom is $n = 3$. It holds six electrons, so

sulfur has six valence electrons. The electron configuration for gallium is $1s^2 2s^2 2p^6 3s^2 3p^6 4s^2 3d^{10} 4p^1$. The outer energy level for this atom is $n = 4$, and it contains three electrons. You must recognize that even though the $3d$ sub-level is mixed in among the $4s$ and $4p$ sub-levels, $3d$ is *not* in the outer energy level, so the electrons in the $3d$ sub-level are *not* valence electrons. Gallium has three electrons in the outer energy level and therefore has three valence electrons. The identification of valence electrons is vital because the chemical behavior of an element is determined primarily by the arrangement of the electrons in the valence shell.

Lewis Dot Diagrams

We can represent the valence electrons of an atom using a **Lewis dot diagram**. A Lewis dot diagram indicates valence electrons as dots around the symbol of the element. A Lewis dot diagram, also known as an electron dot diagram, consists of two parts: the elemental symbol, which represents the core (inner electrons and nucleus), and a group of dots. There can be between 1 through 8 dots, with each dot representing a valence electron.

The electron configuration for sodium (Na) is: $1s^2 2s^2 2p^6 3s^1$. The core electrons are $1s^2 2s^2 2p^6$. The valence electron is $3s^1$. To draw a Lewis electron dot diagram for sodium, you can picture the symbol for sodium in a box with four sides. Each side of the box represents either the s or one of the three p orbitals in the outermost energy level of the atom. The first and second valence electrons are placed on the side representing the s orbital, and the next electrons are placed in the p orbitals. The electron dot diagram also follows Hund's rule, so all the p orbitals in the diagram must contain at least one electron before any of the p orbitals can have a second electron. Since each side can only have two electrons, there can be a maximum of $2 \times 4 = 8$ electrons on any Lewis electron dot diagram. For sodium, a single dot will represent its one valence electron. Thus, the Lewis dot formula for sodium is:



Look at the electron configuration for magnesium shown below. Magnesium is the twelfth element on the periodic table.

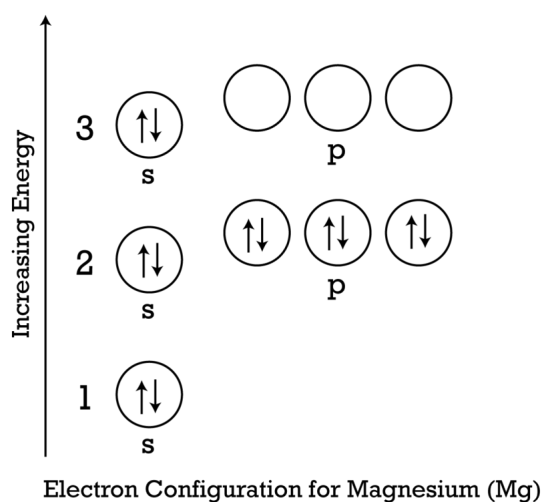

To draw the Lewis electron dot diagram, picture the symbol for magnesium in a box, which represents all of the core electrons ($1s^2 2s^2 2p^6$). Then, place the valence electrons around the sides of the box with each side representing an orbital in the outermost energy level. How many valence electrons does magnesium have? There are 2 valence electrons, as indicated by $3s^2$. Therefore, the Lewis electron dot formula for magnesium is:

Mg:

Look at the electron configuration for chlorine.

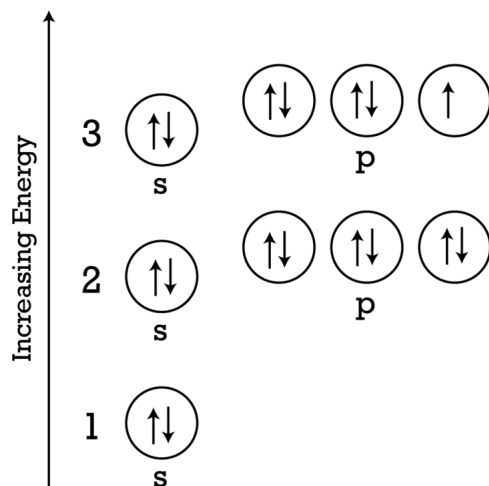

Electron Configuration for Chlorine (Cl)

The electron configuration for chlorine (Cl) could be written as: $1s^2 2s^2 2p^6 3s^2 3p^5$. The core electrons would be $1s^2 2s^2 2p^6$, while the valence electrons would be in the third shell (or where $n = 3$). Therefore, chlorine has 7 valence electrons. The Lewis electron dot diagram would look like the following:

**Example:**

Write the Lewis electron dot formula for:

1. Oxygen
2. Sulfur
3. Potassium
4. Carbon

Solution:

1. Oxygen has the electron configuration: $1s^2 2s^2 2p^4$

The Lewis electron dot formula is:

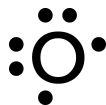

2. Sulfur has the electron configuration: $1s^2 2s^2 2p^6 3s^2 3p^4$

The Lewis electron dot formula is:

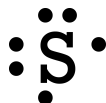

3. Potassium has the electron configuration: $1s^22s^22p^63s^23p^64s^1$

The Lewis electron dot formula is:



4. Carbon has the electron configuration: $1s^22s^22p^2$

The Lewis electron dot formula is:



Lesson Summary

- Valence electrons are the electrons in the outermost principal quantum level of an atom.
- The identification of valence electrons is vital because the chemical behavior of an element is determined primarily by the arrangement of the electrons in the valence shell.
- In a Lewis dot diagram, the chemical symbol is surrounded by a number of dots. Each dot represents a valence electron.

Review Questions

1. How many valence electrons are present in the following electron configuration code?
 - a. $1s^22s^22p^63s^23p^3$
 - b. $1s^22s^22p^63s^23p^64s^23d^{10}4p^1$
2. How many valence electrons does magnesium have?
3. How many valence electrons does oxygen have?
4. Which of the following is the correct orbital representation for the valence shell of phosphorus?

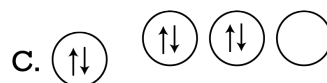
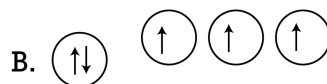
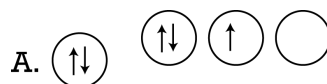

D. None of these.

5. What is the maximum number of dots in a Lewis dot diagram?
6. Draw the Lewis dot diagram for lithium.
7. Draw the Lewis dot diagram for calcium.
8. Draw the Lewis dot diagram for bromine.
9. Draw the Lewis dot diagram for selenium.

All images, unless otherwise stated, are created by the CK-12 Foundation and are under the Creative Commons license CC-BY-NC-SA.

CHAPTER

8

Electron Configuration and the Periodic Table

Chapter Outline

8.1 MENDELEEV'S PERIODIC TABLE

8.2 FAMILIES AND PERIODS OF THE PERIODIC TABLE

8.1 Mendeleev's Periodic Table

Lesson Objectives

The student will:

- identify the person credited for organizing the periodic table.
- state the basis for the organization of Mendeleev's periodic table.

Vocabulary

- periodic table

Introduction

During the 1800s, when most of the elements were being discovered, many chemists tried to classify the elements according to their similarities. In 1829, Johann Dobringer noted chemical similarities in several groups of three elements and placed these elements into what he called triads. His groupings included the triads of 1) chlorine, bromine, and iodine; 2) sulfur, selenium, and tellurium; 3) calcium, strontium, and barium; and 4) lithium, sodium, and potassium.

In 1864, John Newlands saw a connection between the chemical properties of elements and their atomic masses. He stated that if the known elements, beginning with lithium, are arranged in order of increasing mass, the eighth element will have properties similar to the first element, the ninth similar to the second, the tenth similar to the third, and so on. Newlands called his relationship the law of octaves, comparing the elements to the notes in a musical scale. Newlands tried to force all the known elements to fit into his octaves, but many of the heavier elements, when discovered, did not fit into his patterns.

Mendeleev's Table Based on Chemical Behavior

The **periodic table** is a tabular arrangement of the chemical elements according to atomic number. In 1869, Dmitri Mendeleev, unaware of Newlands's work, also developed a table of the elements that showed a relationship between the chemical properties of elements and their atomic masses. His table would be similar to the one we use today. Mendeleev avoided Newlands's mistake of trying to force elements into groups where their chemistry did not match. Instead, he left empty spaces in his table for where no known element fit the properties and atomic mass for that space. He assumed that elements discovered in the future would fit in those spots. Mendeleev even predicted some of the chemical and physical properties the undiscovered elements would have.

Mendeleev's table listed the elements in order of increasing atomic mass and grouped elements with similar chemical behavior together. For example, lithium is a shiny metal that is soft enough to be cut with a spoon. It reacts

readily with oxygen and violently with water. When lithium reacts with water, it produces hydrogen gas and lithium hydroxide. As we examine the next few elements in order of increasing mass, we will come to the element sodium. Sodium is also a shiny metal soft enough to be cut with a spoon. It reacts readily with oxygen and violently with water. When sodium reacts with water, it produces hydrogen gas and sodium hydroxide. You should note that the description of the chemical behavior of sodium is very similar to the chemical description of lithium. Whenever Mendeleev found an element whose chemistry was very similar to a previous element, he placed it below that similar element.

3 Li 1.941 Lithium	4 Be 9.0122 Beryllium	5 B 10.811 Boron	6 C 12.011 Carbon	7 N 14.007 Nitrogen	8 O 15.999 Oxygen	9 F 18.998 Fluorine	10 Ne 20.180 Neon	11 Na 22.990 Sodium
------------------------------------	---------------------------------------	----------------------------------	-----------------------------------	-------------------------------------	-----------------------------------	-------------------------------------	-----------------------------------	-------------------------------------

As each succeeding element was considered, Mendeleev continued to place an element underneath other elements with similar chemistry. For this reason, Mendeleev placed magnesium below beryllium, aluminum under boron, and so on.

3 Li 1.941 Lithium	4 Be 9.0122 Beryllium	5 B 10.811 Boron	6 C 12.011 Carbon	7 N 14.007 Nitrogen	8 O 15.999 Oxygen	9 F 18.998 Fluorine	10 Ne 20.180 Neon
11 Na 22.990 Sodium	12 Mg 24.305 Magnesium	13 Al 26.982 Aluminium	14 Si 28.086 Silicon	15 P 30.974 Phosphorus	16 S 32.065 Sulfur	17 Cl 35.453 Chlorine	18 Ar 39.948 Argon
19 K 39.098 Potassium							

When Mendeleev came to potassium, he found that it had very similar chemistry to the chemistry of lithium and sodium, so he placed potassium under sodium. You may notice that the atomic masses are no longer in increasing order with respect to potassium and argon. Although argon has a greater mass than potassium, the chemistry of argon was identical to that of neon, and the chemistry of potassium was almost identical to that of sodium. As a result, Mendeleev did not try to put argon beneath sodium. Instead, he allowed the chemical behavior determine where each element should be placed. As you go through the periodic table, you will find several elements whose atomic masses are not in increasing order.

Mendeleev's procedure was to place the elements in the column with matching chemical behavior regardless of atomic mass, so if no element with appropriate chemistry was known, the space would be left empty. For example, germanium had not been discovered when Mendeleev constructed his table. After gallium, the next known element in Mendeleev's time was arsenic. Arsenic did not match the chemical characteristics of carbon and silicon. Instead, arsenic matched the chemical characteristics of nitrogen and phosphorus. Mendeleev placed arsenic in the column which matched arsenic's chemistry and assumed that there was an undiscovered element that would fit chemically with the carbon column. As a result, Mendeleev left the space blank, as you can see in the table below. At a later date, when germanium was discovered, germanium was found to fit the space and was placed in the empty spot.

3 Li Lithium 6.941	4 Be Beryllium 9.012											5 B Boron 10.81	6 C Carbon 12.011	7 N Nitrogen 14.007	8 O Oxygen 15.999	9 F Fluorine 18.998	10 Ne Neon 20.180
11 Na Sodium 22.990	12 Mg Magnesium 24.305											13 Al Aluminum 26.982	14 Si Silicon 28.086	15 P Phosphorus 30.974	16 S Sulfur 32.065	17 Cl Chlorine 35.453	18 Ar Argon 39.948
19 K Potassium 39.098	20 Ca Calcium 40.078	21 Sc Scandium 44.956	22 Ti Titanium 47.867	23 V Vanadium 50.942	24 Cr Chromium 51.996	25 Mn Manganese 54.938	26 Fe Iron 55.845	27 Co Cobalt 58.933	28 Ni Nickel 58.693	29 Cu Copper 63.546	30 Zn Zinc 65.38	31 Ga Gallium 69.723	32 Ge Germanium 72.64	33 As Arsenic 74.922	34 Se Selenium 78.96	35 Br Bromine 79.904	36 Kr Krypton 83.80

Lesson Summary

- The periodic table in its present form was organized by Dmitri Mendeleev.
- The basis for Mendeleev's organization was the chemical behavior of the elements.

Further Reading / Supplemental Links

The following websites explore the history behind the periodic table.

- <http://www.wou.edu/las/physci/ch412/perhist.htm>
- <http://www.aip.org/history/curie/periodic.htm>

Review Questions

1. On what basis did Mendeleev organize his periodic table?
 - a. atomic number and atomic mass
 - b. atomic mass and chemical behavior
 - c. atomic number of number of valence electrons
 - d. atomic mass and the Latin alphabet
 - e. none of these

8.2 Families and Periods of the Periodic Table

Lesson Objectives

The student will:

- identify groups in the periodic table.
- state the number of valence electrons for each A group in the periodic table.
- explain the relationship between the chemical behavior of families in the periodic table and their electron configuration.
- identify periods in the periodic table.
- describe the similarities among elements in the same period in the periodic table.

Vocabulary

- actinide series
- alkali metals
- alkaline earth metals
- group (family)
- halogens
- lanthanide series
- noble gases
- period
- transition elements

Introduction

When Mendeleev created his periodic table, he did not know why certain elements had similar chemistry. He placed the elements in their positions because they exhibited similar chemical behaviors. Thus, the vertical columns in Mendeleev's table were composed of elements with similar chemistry. These vertical columns are called **groups**, or families. In this section, you are going to see that the elements in the same groups are related to each other by their electron configurations. Since the families of elements were organized by their chemical behavior, it is predictable that the individual members of each chemical family will have similar electron configurations.

If you examine a periodic table, you will often find a number written above each group (column). These numbers serve as labels, and groups are often referred to by their labels. Depending on the source or age of your periodic table, you may see two different numbering systems for referring to the families on the periodic table. In the older system, the numbers 1 – 8 and the letters A and B were used to label the groups. The newer convention is to label each group from 1 – 18 in sequential order. However, the older labeling scheme helps to provide more insight into the electron configurations of each group. As a result, in this text we will use the older labeling scheme to present each group. The periodic table below shows both numbering systems.

For an introduction to the electronic organization of the periodic table (1a, 1c, 1d, 1f), see <http://www.youtube.com/watch?v=5MMWpeJ5dn4> (3:51).

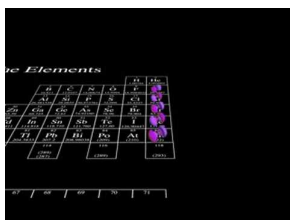

MEDIA

Click image to the left for more content.

Group 1A

The electron configuration codes for the elements in Group 1A are:

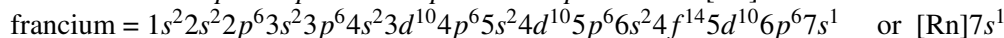
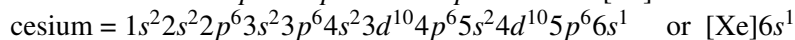
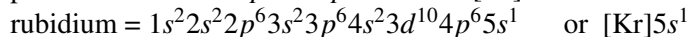
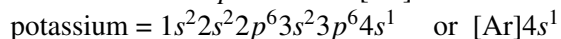
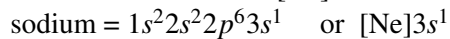
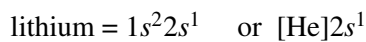

The fact that all 1A elements participate in similar chemistry despite having vastly different nuclear sizes further illustrates the fact that electrons, particularly valence electrons, are the primary contributors to chemical reactivity. The electron configuration for the outermost energy levels of the 1A elements is the same, with the only difference being the energy level involved. Each larger member of the family has its single s electron in the next larger principal energy level. As the atomic sizes in this family increase, the valence electrons are located further from the nucleus and are therefore easier to lose. Lithium reacts readily with water, sodium reacts violently with water, potassium reacts so violently that the hydrogen formed begins to burn, and rubidium explodes instantly in water. The differences in these chemical reactions are just a matter of degree. Each larger atom reacts in the same way as the one before, but it reacts faster. The speed and ease of reaction of elements is referred to as reactivity. The relative reactivity of

the elements in the 1A family (also called **alkali metals**) increases as the atoms become larger. Note that in the new labeling scheme, this group is labeled as Group 1.

All of the 1A elements have one valence electron and react in similar ways as the other members of the family – that's why they are a part of the same family. The 1A metals have similar electron configurations, which causes them to have similar chemistry. Although Mendeleev did not know about these elements had similar electron configurations, he recognized the similar chemistry and organized the periodic table based on this similar chemistry.

Group 2A

Here are the electron configuration codes for the first five elements in Group 2A:

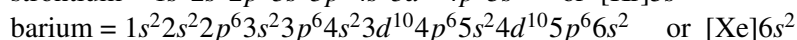
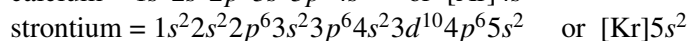
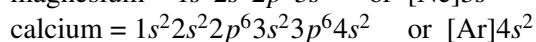
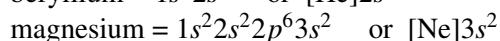
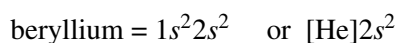

All of the elements in this family have two valence electrons and have very similar chemistry. This group of metals is called the **alkali earth metals**. As with the 1A family, the elements in this family also increase in reactivity as the elements become larger and the valence electrons are held more loosely. In the new labeling conventions, this group is labeled as Group 2.

Group 3A

The electron configurations of Group 3A (Group 3 according to new labeling conventions) show that all the members of this family have three valence electrons. The chemical behaviors of the elements in this family are similar to each other, but they are not as consistent from element to element as they are for other families of elements. Information in the following sections will explain why.

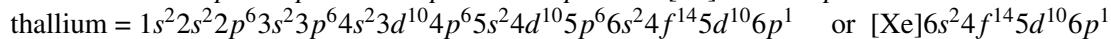
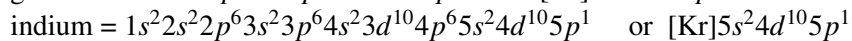
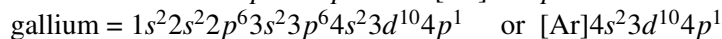
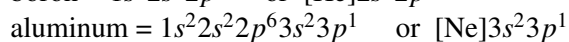
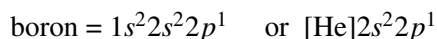

Groups 4A through 8A

Group 4A (also known as Group 14) members have four valence electrons.

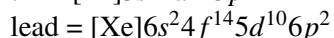
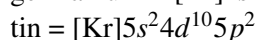
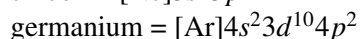
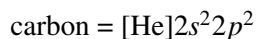

Group 5A (or Group 15) members have five valence electrons.

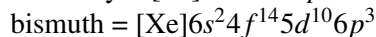
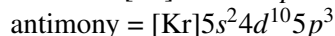
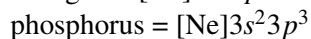
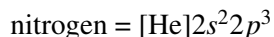

Instead of showing you the electron configurations for Groups 6A (or Group 16), 7A (or 17), and 8A (or 18), it would be good practice for you to practice writing the electron configurations for these families. When you finish writing them, check to make sure that the outer energy levels contain six valence electrons, seven valence electrons, and eight valence electrons for Groups 6A, 7A, and 8A, respectively. The group label provides a hint about the valence electrons: the number preceding the “A” is equal to the number of valence electrons for each atom in the group.

Groups 7A and 8A are also known by the names **halogens** and the **noble gases**, respectively. Groups 7A and 8A were two of the first families identified because the chemistry of their members are so similar to each other.

Transition Elements

If you have been checking where the different groups that have been introduced so far are located on the periodic table, you may have noticed that there are a series of elements that are not part of Groups 1A – 8A (sometimes refer to as the main group). In some periodic tables, these groups of elements are in families called B groups, and in newer periodic tables, these groups are numbered 3 – 12.

Consider the fourth horizontal row in the periodic table. For potassium, the first element in this row, one electron resides in the 4s orbital. For calcium, a second electron is added to the 4s orbital. Beyond calcium, however, the pattern in which the electrons are added changes. Beginning with scandium, atomic number 21, the additional electrons do not enter the valence shell but instead enter the **d** sub-level of the third energy level ($n = 3$), as illustrated below. The electron configuration for scandium is $[\text{Ar}]4s^23d^1$.

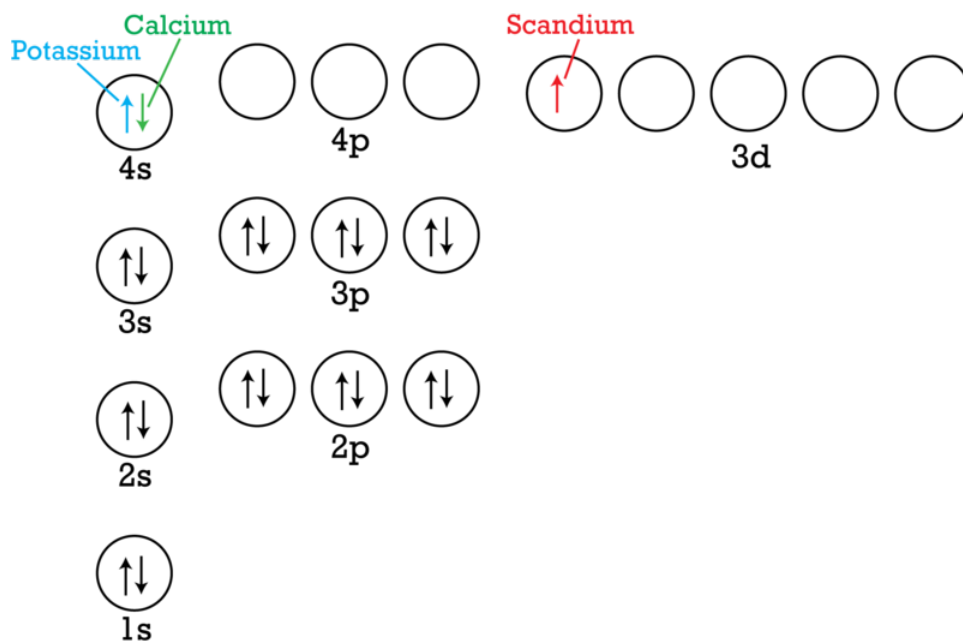

The ten elements formed by filling in the $3d$ orbitals, as well as all other elements that have between 1 to 10 electrons in d orbitals, are called the **transition elements**. These elements, in general, differ from each other in the electron structure of the next-to-last energy level. For the most part, these elements have similar outer energy levels because they have two valence electrons. As a result, they have somewhat similar chemistry, even though they are not in the same vertical family.

The Lanthanide and Actinide Series

There is still one more block of elements on the periodic table that has not been introduced. This block is usually placed below the periodic table and represents elements with electrons in the f orbitals. In the sixth horizontal row, the first electron goes into the $6s$ orbital and produces the element cesium. The second electron fills the $6s$, orbital producing the element barium. The next 14 electrons that are added then enter the $4f$ orbitals (marked in red in the figure below).

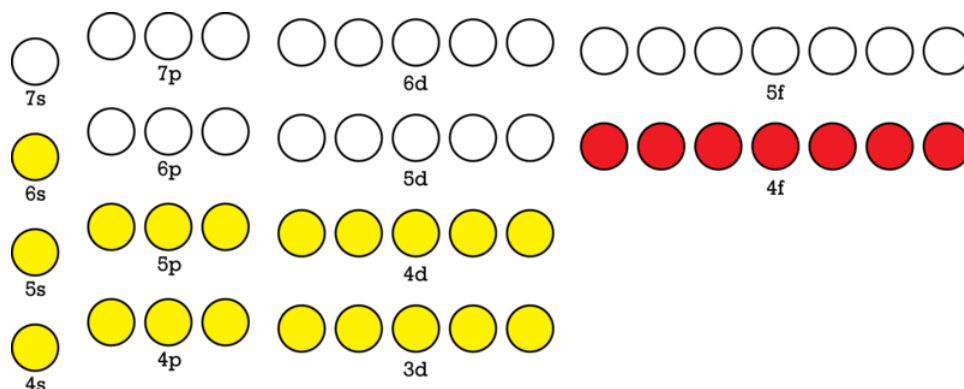

This group of elements, atomic numbers 57 – 70, is called the **lanthanide series**. Elements with atomic numbers 89 – 102 are called the **actinide series**. As in the case of the transition elements, these elements have the electrons added to an inner energy level, rather than the valence shell. The number of valence electrons in these elements remains at 2 while the electrons enter and eventually fill the f orbitals. For some of the elements with more complicated electron configuration, this is a somewhat simplified way to generate the electron configurations. Due to the fact that outer orbitals, such as $5f$ and $6d$, have increasingly similar energies, other factors can come into play and change the exact configuration of the lanthanides, actinides, and some transition metals.

Sub-Level Filling Blocks on the Periodic Table

For Groups 1A and 2A, the last electron added enters an s orbital. For this reason, the 1A and 2A families make up an area on the periodic table known as the “ s block.” In Groups 3A, 4A, 5A, 6A, 7A, and 8A, the last electron enters a p orbital. These six families of elements, therefore, make up an area called the “ p block.” The various sub-level blocks, including the “ d block” and “ f block,” are indicated in the periodic table shown below.

PERIODIC TABLE OF ELEMENTS

The periodic table is organized into four main blocks:

- S Block:** Groups 1 and 2, including elements like Li, Na, K, Rb, Cs, Fr and Be, Mg, Ca, Sr, Ba, Ra.
- D Block:** Transition metals, groups 3-10, including elements like Sc, Ti, V, Cr, Mn, Fe, Co, Ni, Cu, Zn, Ga, Ge, As, Se, Br, Kr, Rb, Sr, Y, Zr, Nb, Mo, Tc, Ru, Rh, Pd, Ag, Cd, In, Sn, Sb, Te, I, Xe, Ba, La-Lu, Hf, Ta, W, Re, Os, Ir, Pt, Au, Hg, Tl, Pb, Bi, Po, At, Rn, Ac-Lr, Rf, Db, Sg, Bh, Hs, Mt, Ds, Rg, Cn, Uut, Uuq, Uup, Uuh, Uus, Uuo.
- P Block:** Groups 13-18, including elements like B, C, N, O, F, Ne, Al, Si, P, S, Cl, Ar, Ga, Ge, As, Se, Br, Kr, In, Sn, Sb, Te, I, Xe, Tl, Pb, Bi, Po, At, Rn, Uut, Uuq, Uup, Uuh, Uus, Uuo.
- F Block:** Lanthanides (groups 3-10) and Actinides (groups 3-10), including elements like La, Ce, Pr, Nd, Pm, Sm, Eu, Gd, Tb, Dy, Ho, Er, Tm, Yb, Lu and Ac, Th, Pa, U, Np, Pu, Am, Cm, Bk, Cf, Es, Fm, Md, No, Lr.

Even though the periodic table was organized according to the chemical behavior of the elements, you can now see that the shape and design of the table is a perfect reflection of the electron configuration of the atoms. This is because the chemical behavior of the elements is also dictated by the electron configuration of the atoms.

Periods of the Periodic Table

In addition to providing information about the electron configuration, an element's position on the periodic table can also be used to figure out the energy level of the element's valence electrons. Let's try to figure out what we can learn from an element's period in the periodic table. A **period** is a horizontal row of elements on the periodic table. The figure below shows how the different rows in the periodic table are numbered.

	1						18	
	1A						8A	
ROW 1	1 H [1.00784; 1.00811] HYDROGEN	2	13	14	15	16	17	2 He 4.0026 HELIUM
		2A	3A	4A	5A	6A	7A	
ROW 2	3 Li [6.938; 6.997] LITHIUM	4 Be 9.0122 BERYLLIUM	5 B [10.806; 10.821] BORON	6 C [12.0096; 12.0116] CARBON	7 N [14.00643; 14.00728] NITROGEN	8 O [15.99903; 15.99977] OXYGEN	9 F 18.998 FLUORINE	10 Ne 20.180 NEON
ROW 3	11 Na 22.990 SODIUM	12 Mg 24.305 MAGNESIUM	13 Al 26.982 ALUMINUM	14 Si [28.084; 28.086] SILICON	15 P 30.974 PHOSPHORUS	16 S [32.059; 32.076] SULFUR	17 Cl [35.446; 35.457] CHLORINE	18 Ar 39.948 ARGON
ROW 4	19 K 39.098 POTASSIUM	20 Ca 40.078 CALCIUM	31 Ga 69.723 GALLIUM	32 Ge 69.723 GERMANIUM	33 As 74.922 ARSENIC	34 Se 78.963 SELENIUM	35 Br 79.904 BROMINE	36 Kr 83.801 KRYPTON
ROW 5	37 Rb 85.468 RUBIDIUM	38 Sr 87.62 STRONTIUM	49 In 114.818 INDIUM	50 Sn 114.818 TIN	51 Sb 121.760 ANTIMONY	52 Te 127.603 TELLURIUM	53 I 126.904 IODINE	54 Xe 131.292 XENON
ROW 6	55 Cs 132.905 CESIUM	56 Ba 137.327 BARIUM	81 Tl [204.382; 204.385] THALLIUM	82 Pb 204.383 LEAD	83 Bi 208.980 BISMUTH	84 Po 208.982 POLONIUM	85 At 209.987 ASTATINE	86 Rn 222.018 RADON
ROW 7	87 Fr 223.020 FRANCIUM	88 Ra 226.0254 RADIUM	113 Uut 284 UNUNTRIUM	114 Uuq 284 UNUNQUADIUM	115 Uup 288 UNUNPENTIUM	116 Uuh 292 UNUNHEXIUM	117 Uus 294 UNUNSEPTIUM	118 Uuo 294 UNUNOCTIUM

To understand what this means in terms of an element's electron configuration, let's consider the Group 1A metals. If we write the electron configuration for the Group 1A metal from each row of the Periodic Table, we have:

row	element	electron configuration
2	Li	$1s^2 2s^1$
3	Na	$1s^2 2s^2 2p^6 3s^1$
4	K	$1s^2 2s^2 2p^6 3s^2 3p^6 4s^1$
5	Rb	$1s^2 2s^2 2p^6 3s^2 3p^6 4s^2 3d^{10} 4p^6 5s^1$
6	Cs	$1s^2 2s^2 2p^6 3s^2 3p^6 4s^2 3d^{10} 4p^6 5s^2 4d^{10} 5p^6 6s^1$
7	Fr	$1s^2 2s^2 2p^6 3s^2 3p^6 4s^2 3d^{10} 4p^6 5s^2 4d^{10} 5p^6 6s^2 4f^{14} 5d^{10} 6p^6 7s^1$

Do you see any patterns? For Group 1A metals, it seems that element's row corresponds to the energy level of that element's valence electron. Lithium (Li), for instance, is found in row 2 of the periodic table, and its valence electron is found in the $n = 2$ energy level. Cesium (Cs) is found in row 6 of the periodic table, and its valence electron is found in the $n = 6$ energy level. Now consider the Group 2A metals:

row	element	electron configuration
2	Be	$1s^2 2s^2$
3	Mg	$1s^2 2s^2 2p^6 3s^2$
4	Ca	$1s^2 2s^2 2p^6 3s^2 3p^6 4s^2$
5	Sr	$1s^2 2s^2 2p^6 3s^2 3p^6 4s^2 3d^{10} 4p^6 5s^2$
6	Ba	$1s^2 2s^2 2p^6 3s^2 3p^6 4s^2 3d^{10} 4p^6 5s^2 4d^{10} 5p^6 6s^2$
7	Ra	$1s^2 2s^2 2p^6 3s^2 3p^6 4s^2 3d^{10} 4p^6 5s^2 4d^{10} 5p^6 6s^2 4f^{14} 5d^{10} 6p^6 7s^2$

For Group 2A metals, the same rule applies. Magnesium (Mg) is found in row 3 of the periodic table, and its valence electrons are found in the $n = 3$ energy level. Similarly, radium (Ra) is found in row 7 of the periodic table, and its valence electrons are found in the $n = 7$ energy level.

Consider the electron configurations for the Group 3A elements in each row:

row	element	electron configuration
2	B	$1s^2 2s^2 2p^1$
3	Al	$1s^2 2s^2 2p^6 3s^2 3p^1$
4	Ga	$1s^2 2s^2 2p^6 3s^2 3p^6 4s^2 3d^{10} 4p^1$
5	In	$1s^2 2s^2 2p^6 3s^2 3p^6 4s^2 3d^{10} 4p^6 5s^2 4d^{10} 5p^1$
6	Tl	$1s^2 2s^2 2p^6 3s^2 3p^6 4s^2 3d^{10} 4p^6 5s^2 4d^{10} 5p^6 6s^2 5d^{10} 6p^1$

Even though the valence electrons in Group 3A elements are found in both **s** and **p** orbitals, it turns out that an element's row still corresponds to the energy level of that element's valence electrons. For example, gallium (Ga) is found in row **4** of the periodic table, and its valence electrons are found in the $n = 4$ energy level. Likewise, thallium (Tl) is found in row **6** of the periodic table, and its valence electrons are found in the $n = 6$ energy level.

Let's consider one last example by examining the electron configurations for the Group 7A elements:

row	element	electron configuration
2	F	$1s^2 2s^2 2p^5$
3	Cl	$1s^2 2s^2 2p^6 3s^2 3p^5$
4	Br	$1s^2 2s^2 2p^6 3s^2 3p^6 4s^2 3d^{10} 4p^5$
5	I	$1s^2 2s^2 2p^6 3s^2 3p^6 4s^2 3d^{10} 4p^6 5s^2 4d^{10} 5p^5$
6	At	$1s^2 2s^2 2p^6 3s^2 3p^6 4s^2 3d^{10} 4p^6 5s^2 4d^{10} 5p^6 6s^2 5d^{10} 6p^5$

Once again, it turns out that an element's period can be used to determine the energy level of that element's valence electrons. Chlorine (Cl), for instance, is found in row **3** of the periodic table, and its valence electrons are found in the $n = 3$ energy level. Similarly, iodine (I) is found in row 5 of the periodic table, and its valence electrons are found in the $n = 5$ energy level.

Note, however, that determining the energy level of an element's valence electrons by using the element's row number works only for Groups 1A – 8A. This rule *does not* apply to Groups 1B – 8B (also known as Groups 3 – 12) or to lanthanides and actinides. The elements in these groups behave differently and do not obey the same rules as the Group 1A – 8A elements in terms of valence electrons and valence electron energy levels.

You may have noticed that the first row has not been mentioned at all. In all of the examples considered, only the elements starting from the second row were considered. The first row in the periodic table is a “special row” for several reasons. To begin with, the first row only contains hydrogen and helium. Can you figure out why there are only two elements in the first row?

Recall that an element's period number corresponds to the energy level of that element's valence electrons. Therefore, the first row must contain elements with valence electrons in the $n = 1$ energy level. In the $n = 1$ energy level, there is only one orbital: the $1s$ orbital. Hydrogen (electron configuration $1s^1$) has one valence electron in the $1s$ orbital, and helium (electron configuration $1s^2$) has two valence electrons in the $1s$ orbital. Since it is impossible to fit more than two electrons into the $1s$ orbital, atoms with a total of three or more electrons must have valence electrons in an energy level with $n = 2$ or greater. Atoms with a total of three or more electrons do not belong in the first row of the periodic table.

The first row is also special because its elements have special properties. Hydrogen, for example, is not a metal like the rest of the Group 1A elements. Instead, hydrogen atoms react with each other and form hydrogen gas, H_2 . Hydrogen is different from the other Group 1A elements, so the chemical properties of hydrogen cannot be compared with the chemical properties of the other elements in Group 1A.

The second element in the first row, helium, is also a special atom. Helium is noticeably placed away from hydrogen at the far right-hand side of the periodic table. Helium's placement reflects its special chemical properties. While helium only has two valence electrons when the rest of the Group 8A elements have eight, helium is grouped with the 8A family because helium's chemical behavior is similar to the chemical behaviors of the other noble gases. This is because helium and the other noble gases all have a completed outer energy shell, even though the number of valence electrons is different.

This video describes the organization and family properties within the periodic table (**1b, 1c, 1f**): <http://www.youtube.com/watch?v=rD0maRGQhU8> (4:45).

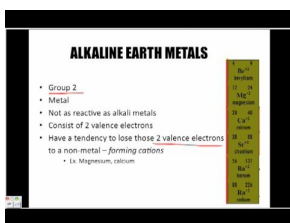

MEDIA

Click image to the left for more content.

Lesson Summary

- The vertical columns on the periodic table are called groups or families because the elements in the column exhibit similar chemical behaviors.
- The groups on the periodic table also have similar electron configurations.
- The electron configuration in the outer energy level of the atoms in a family is the same, with the only difference in the electron configurations being the number of the outer energy level.
- All the members of a family of elements have the same number of valence electrons.
- The blocks of elements in the periodic table correspond to the sub-level in which the last electrons are being added.
- The horizontal rows on the periodic table are called periods.
- You can predict the energy level of an element's valence electrons using the element's period number in the periodic table.
- For the elements in Groups 1A, 2A, 3A, 4A, 5A, 6A, 7A, and 8A, the period in which an element is found corresponds to the energy level of that element's valence electrons.

Further Reading / Supplemental Links

This website provides a dynamic periodic table that also provides information about the orbitals and electron configurations of the elements.

- <http://www.dayah.com/periodic>
- A video on electron configuration and the periodic table.
– <http://video.yahoo.com/watch/193832/925988>

This website reviews the different groups in the periodic table.

- <http://www.chemtutor.com/perich.htm>

This video is a ChemStudy film called “Transuranium Elements.” The film is somewhat dated but the information is accurate.

- <http://www.youtube.com/watch?v=SpQSEN1n4HE>

This video is a ChemStudy film called “Inert Gas Compounds.” The film is somewhat dated but the information is accurate.

- <http://www.youtube.com/watch?v=QASDy4bLQxs>

Review Questions

- The horizontal rows in the periodic table are called _____.
- The vertical columns in the periodic table are called _____.
- Elements in a _____ have similar chemical properties.
 - period
 - family
 - both a and b
 - neither a nor b
- Which of the following elements is in the same family as fluorine?
 - silicon
 - antimony
 - iodine
 - arsenic
 - None of these.
- Which of the following is a noble gas?
 - polonium
 - astatine
 - krypton
 - hydrogen
 - francium
- Name the period (horizontal row) and the sub-level (*s*, *p*, *d*, *f*) of the valence electrons for the following elements. Then indicate the number of valence electrons for that element.
 - hydrogen
 - carbon
 - sulfur
 - barium
 - iodine
- Of the s-block, p-block, d-block, and f-block of elements, which block contains most of the nonmetals?
- Why are there no transition elements in periods 1 and 2?
- Why do many of the transition elements have similar chemistry?
- Use the periodic table to determine the energy level and sub-level of the highest energy electrons in each of the following elements:
 - N
 - Ca
 - Rb
 - P
 - In
- Decide whether each of the following statements is true or false.
 - Li has valence electrons in the $n = 1$ energy level.
 - Si has valence electrons in the $n = 3$ energy level.
 - Ga has valence electrons in the $n = 3$ energy level.
 - Xe has valence electrons in the $n = 5$ energy level.
 - P has valence electrons in the $n = 2$ energy level.

All images, unless otherwise stated, are created by the CK-12 Foundation and are under the Creative Commons license CC-BY-NC-SA.

CHAPTER 9**Chemical Periodicity****Chapter Outline**

- 9.1 THE PERIODIC TABLE**
 - 9.2 PERIODIC TRENDS IN ATOMIC SIZE**
 - 9.3 PERIODIC TRENDS IN IONIC SIZE**
 - 9.4 PERIODIC TRENDS IN IONIZATION ENERGY**
 - 9.5 PERIODIC TRENDS IN ELECTRONEGATIVITY**
 - 9.6 PERIODIC TRENDS IN ELECTRON AFFINITY**
-

9.1 The Periodic Table

Lesson Objectives

The student will:

- explain the periodic law.
 - describe the differences among metals, nonmetals, and metalloids.
 - draw a rough sketch of the modern periodic table and indicate the portion of the table occupied by metals, nonmetals, and metalloids.
 - identify the stair-step line that separates the metallic elements from the nonmetallic ones.
-

Vocabulary

- ductile
 - malleable
 - periodic law
-

Introduction

In the periodic table, the elements are arranged according to similarities in their properties. The elements are listed in order of increasing atomic number as you read from left to right across a period. In this chapter, you will learn the general behavior and trends within the periodic table that result from this arrangement in order to predict the properties of the elements.

The Periodic Law

The periodic table is a powerful tool that provides a way for chemists to organize the chemical elements. The word “periodic” means happening or recurring at regular intervals. The **periodic law** states that the properties of the elements recur periodically as their atomic numbers increase. This is because the electron configurations of the atoms vary periodically with their atomic number. Since the physical and chemical properties of elements depend on their electron configurations, many of the physical and chemical properties of the elements also tend to repeat in a pattern.

You may recall that the periodic table was created by Russian scientist Dmitri Mendeleev. Mendeleev used similarities in properties to construct his periodic table of the elements. He was even able to predict the properties of several elements missing from the periodic table by using the properties of neighboring elements. Mendeleev arranged the elements in a table by increasing atomic weight, although he sometimes had to ignore the atomic weights in order to group elements with similar chemical behaviors together.

The work of Henry Moseley led to the arrangement of elements based on their properties and atomic numbers, *not* atomic masses, which cleared up the inconsistencies of Mendeleev's arrangement. Moseley's periodic table is now considered the current periodic table.

Metals, Nonmetals, and Metalloids

There is a progression from metals to nonmetals across each period of elements in the periodic table. The diagonal line at the right side of the table shown below separates the elements into two groups: the metals and the nonmetals. The elements that are on the left of this line tend to be metals, while those to the right tend to be nonmetals. The elements that are directly on the diagonal line are metalloids. Metallic character generally increases from top to bottom down a group and right to left across a period. The noticeable exception is hydrogen, which is grouped with the metals but is actually a nonmetal.

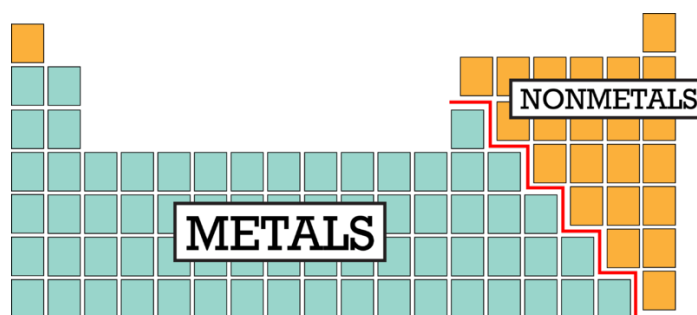

Most of the chemical elements are metals. Most metals have the common properties of being shiny, being very dense, and having high melting points. Metals tend to be **ductile** (can be drawn out into thin wires) and **malleable** (can be hammered into thin sheets). Metals are good conductors of heat and electricity. All metals are solids at room temperature except for mercury. In chemical reactions, metals easily lose electrons to form positive ions. Examples of metals are silver, gold, and zinc.

Nonmetals are generally brittle, dull, and have low melting points. They are generally poor conductors of heat and electricity. In chemical reactions, they tend to gain electrons to form negative ions. Examples of nonmetals are hydrogen, carbon, and nitrogen.

Metalloids have properties of both metals and nonmetals. Metalloids can be shiny or dull. Electricity and heat can travel through metalloids, although not as easily as they can through metals. They are also called semi-metals. They are typically semiconductors, which means that they conduct electricity better than insulators, but not as well as conductors. Semiconductors are valuable in the computer chip industry. Examples of metalloids are silicon and boron.

Lesson Summary

- The word “periodic” means happening or recurring at regular intervals.
- The periodic law states that the properties of the elements recur periodically as their atomic numbers increase.
- There is a progression from metals to nonmetals across each period of elements in the periodic table.
- Metallic character generally increases from top to bottom down a group and right to left across a period.

Further Reading / Supplemental Links

This video is on the periodic table.

- <http://www.youtube.com/watch?v=1geccHiylcU&feature=fvw>

Review Questions

1. Why is the table of elements called “the periodic table”?
 - a. It describes the periodic motion of celestial bodies.
 - b. It describes the periodic recurrence of chemical properties.
 - c. Because the rows are called periods.
 - d. Because the elements are grouped as metals, metalloids, and nonmetals.
 - e. None of these.
2. Which of the following elements is a nonmetal?
 - a. oxygen
 - b. lead
 - c. iron
 - d. zinc
 - e. All of these are metals.
3. Which of the following metals is *not* an element?
 - a. gold
 - b. silver
 - c. copper
 - d. bronze
 - e. All of these are elements.
4. Which of the following elements is a metalloid?
 - a. chlorine
 - b. magnesium
 - c. rhenium
 - d. boron
 - e. None of these.

9.2 Periodic Trends in Atomic Size

Lesson Objectives

The student will:

- define atomic radius.
- define the shielding effect.
- describe the factors that determine the trend in atomic size.
- describe the general trend in atomic size for groups and periods.
- use the general trends to predict the relative sizes of atoms.
- describe variations that occur in the general trend of atomic size in the transition metals.

Vocabulary

- atomic radius
- diatomic molecule
- nuclear charge
- shielding effect

Introduction

In the periodic table, there are a number of physical properties that are trend-like. This means that as you move down a group or across a period, you will see the properties changing in a general direction. The actual trends that are observed with atomic size have to do with three factors. These factors are:

1. the number of protons in the nucleus (called the **nuclear charge**).
2. the number of energy levels holding electrons and the number of electrons in the outer energy level.
3. the number of electrons held between the nucleus and its outermost electrons (called the **shielding effect**).

Atomic Radius Defined

The gold foil experiment performed by Rutherford in 1911 (see the chapter “The Atomic Theory” for more details), was the first experiment that gave scientists an approximate measurement for the size of the atom. The atomic size is the distance from the nucleus to the valence shell, where the valence electrons are located. Using the technology available in the early part of the 1900s, Rutherford was able to determine quantitatively that the nucleus had a radius size smaller than 3×10^{-12} cm. The size of the atom is significantly larger, being approximately 2×10^{-8} cm in diameter.

The region in space occupied by the electron cloud of an atom is often thought of as a probability distribution of the electron positions. Consequently, there is no well-defined outer edge of the electron cloud. Because it is so difficult to measure atomic size from the nucleus to the outermost edge of the electron cloud, chemists use other approaches to get consistent measurements of atomic sizes.

Atomic size is defined in several different ways, which often produce some variations in the measurement of atomic sizes. One way that chemists define atomic size is by using the atomic radius. The **atomic radius** is one-half the distance between the centers of a homonuclear diatomic molecule, as illustrated below. A **diatomic molecule** is a molecule made of exactly two atoms, while homonuclear means both atoms are the same element.

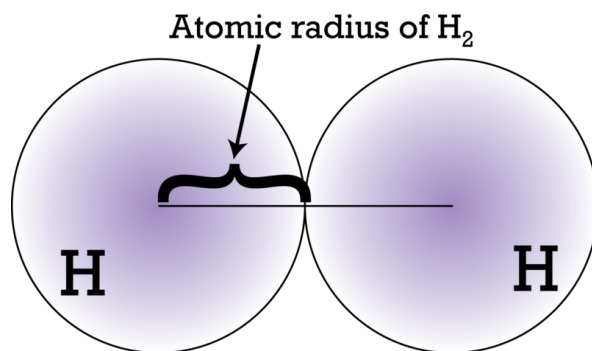

Group Trends in Atomic Radii

Let's now look at how the atomic radii changes from the top of a family to the bottom. Take, for example, the Group 1A metals (see **Table 9.1**). Every atom in this family has the same number of electrons in the outer energy level (true for all main group families). Each period in the periodic table represents another added energy level. When we first learned about principal energy levels, we learned that each new energy level was larger than the one before. Therefore, as we move down the periodic table, each successive period represents the addition of a larger energy level, thus increasing the atomic radius.

TABLE 9.1: Group 1A Data

Element	Number of Protons	Electron Configuration
Lithium (Li)	3	[He] $2s^1$
Sodium (Na)	11	[Ne] $3s^1$
Potassium (K)	19	[Ar] $4s^1$
Rubidium (Rb)	37	[Kr] $5s^1$
Cesium (Cs)	55	[Xe] $6s^1$

One other contributing factor to atomic size is the shielding effect. The protons in the nucleus attract the valence electrons in the outer energy level, but the strength of this attraction depends on the size of the charges, the distance between the charges, and the number of electrons between the nucleus and the valence electrons. The presence of the core electrons weakens the attraction between the nucleus and the valence electrons. This weakening is called the shielding effect. Note that although valence electrons do participate in shielding, electrons in the same energy level do not shield each other as effectively as the core electrons do. As a result, the amount of shielding primarily depends on the number of electrons between the nucleus and the valence electrons. When the nucleus pulls strongly on the valence electrons, the valence shell can be pulled in tighter and closer to the nucleus. When the attraction is weakened by shielding, the valence shell cannot be pulled in as close. The more shielding that occurs, the further the valence shell can spread out.

For example, if you are looking at the element sodium, it has the electron configuration:

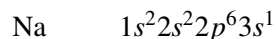

The outer energy level is $n = 3$. There is one valence electron, but the attraction between this lone valence electron and the nucleus, which has 11 protons, is shielded by the other 10 inner (or core) electrons.

When we compare an atom of sodium to one of cesium, we notice that the number of protons increases, as well as the number of energy levels occupied by electrons. The increase in the number of protons, however, is also accompanied by the same increase in the number of shielding electrons.

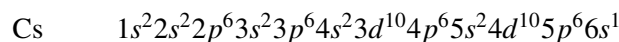

The result is that the valence electron in both atoms feels a similar pull from the nucleus, but the valence electron in the cesium atom is further from the nucleus because it is in a higher energy level. Compared to the shielding effect, the increase in the number of energy levels has a greater impact on the atom's size. Consequently, the size of a cesium atom is larger than that of a sodium atom.

This is true for not only Group 1A metals, but for all of the groups across the periodic table. For any given group, as you move downward in the periodic table, the size of the atoms increases. For instance, the largest atoms in the halogen family are bromine and iodine (astatine is radioactive and only exists for short periods of time, so we won't include it in the discussion). You can imagine that with the increase in the number of energy levels, the size of the atom must increase. The increase in the number of energy levels in the electron cloud takes up more space.

The periodic table below shows the trend of atomic size for groups, with the arrow indicating the direction of the increase.

Atomic Size

1 H 1.00794 HYDROGEN	2 He 4.002602 HELIUM																	
3 Li 6.941 LITHIUM	4 Be 9.0122 BERYLLIUM											5 B 10.811 BORON	6 C 12.011 CARBON	7 N 14.007 NITROGEN	8 O 15.999 OXYGEN	9 F 18.998 FLUORINE	10 Ne 20.180 NEON	
11 Na 22.990 SODIUM	12 Mg 24.305 MAGNESIUM											13 Al 26.982 ALUMINUM	14 Si 28.086 SILICON	15 P 30.974 PHOSPHORUS	16 S 32.065 SULFUR	17 Cl 35.453 CHLORINE	18 Ar 39.948 ARGON	
19 K 39.098 POTASSIUM	20 Ca 40.078 CALCIUM	21 Sc 44.956 SCANDIUM	22 Ti 47.883 TITANIUM	23 V 50.942 VANADIUM	24 Cr 51.996 CHROMIUM	25 Mn 54.938 MANGANESE	26 Fe 55.845 IRON	27 Co 58.933 COBALT	28 Ni 58.693 NICKEL	29 Cu 63.546 COPPER	30 Zn 65.38 ZINC	31 Ga 69.723 GALLIUM	32 Ge 72.631 GERMANIUM	33 As 74.922 ARSENIC	34 Se 78.96 SELENIUM	35 Br 79.904 BROMINE	36 Kr 83.80 KRYPTON	
37 Rb 85.468 RUBIDIUM	38 Sr 87.62 STRONTIUM	39 Y 88.906 YTIORIUM	40 Zr 91.224 ZIRCONIUM	41 Nb 92.906 NIOBIUM	42 Mo 95.94 MOLYBDENUM	43 Tc 98.906 TECHNETIUM	44 Ru 101.07 RUTHENIUM	45 Rh 101.07 RHODIUM	46 Pd 106.36 PALLADIUM	47 Ag 107.868 SILVER	48 Cd 112.411 CADMIUM	49 In 114.818 INDIUM	50 Sn 118.710 TIN	51 Sb 121.757 ANTIMONY	52 Te 127.603 TELLURIUM	53 I 126.905 IODINE	54 Xe 131.29 XEON	
55 Cs 132.905 CESIUM	56 Ba 137.327 BARIUM	57-71 LANTHANIDES		72 Hf 178.49 HAFNIUM	73 Ta 180.948 TANTALUM	74 W 183.84 WOLYBDENUM	75 Re 186.207 RHENIUM	76 Os 190.23 OSMIUM	77 Ir 192.222 IRIDIUM	78 Pt 195.084 PLATINUM	79 Au 196.967 GOLD	80 Hg 200.59 MERCURY	81 Tl 204.387 THALLIUM	82 Pb 207.2 LEAD	83 Bi 208.980 BISMUTH	84 Po 209 POLONIUM	85 At 210 ASTATINE	86 Rn 222 RADON
87 Fr 223 FRANCIUM	88 Ra 226 RADIUM	89-103 ACTINIDES		104 Rf 261 RUFORDIUM	105 Db 262 DUBNIUM	106 Sg 263 SEABORGIUM	107 Bh 264 BOHRIUM	108 Hs 265 HASSIUM	109 Mt 266 MEITNERIUM	110 Ds 271 DARMSTADIUM	111 Rg 272 ROSGONIUM	112 Cn 285 COGNACIUM	113 Uut 288 UNUNTRIUM	114 Uuq 289 UNUNQUADIUM	115 Uup 288 UNUNPENTIUM	116 Uuh 289 UNUNHEXADIUM	117 Uus 289 UNUNSEPTIUM	118 Uuo 289 UNUNOCTIUM
		57 La 138.905 LANTHANUM	58 Ce 140.12 CELIUM	59 Pr 140.908 PRASEODYMIUM	60 Nd 144.24 NEODYMIUM	61 Pm 144.913 PROMETHIUM	62 Sm 150.36 SAMARIUM	63 Eu 151.964 EUROPEUM	64 Gd 157.25 GADOLINIUM	65 Tb 158.925 TERBIUM	66 Dy 162.50 DYSPROSIUM	67 Ho 164.930 HOLMIUM	68 Er 167.259 ERBIUM	69 Tm 168.930 THULIUM	70 Yb 173.054 YTERBIUM	71 Lu 174.967 LUTETIUM		
		89 Ac 227 ACTINIUM	90 Th 232.038 THORIUM	91 Pa 231.036 PROTACTINIUM	92 U 238.029 URANIUM	93 Np 237.048 NEPTUNIUM	94 Pu 244.064 PLUTONIUM	95 Am 243.061 AMERICIUM	96 Cm 247.077 CURIUM	97 Bk 247.077 BERKELIUM	98 Cf 251.083 CALIFORNIUM	99 Es 252.083 EINSTEINIUM	100 Fm 257.103 FERMIUM	101 Md 258.103 Mendelevium	102 No 259.103 Nobelium	103 Lr 260.103 Lawrencium		

Example:

Which of the following is larger? Explain.

- As or Sb
- Ca or Be
- polonium or sulfur

Solution:

1. Sb, because it is below As in Group 15.
2. Ca, because it is below Be in Group 2.
3. Polonium, because it is below sulfur in Group 16.

Period Trends in Atomic Radii

In order to determine the trend for the periods, we need to look at the number of protons (nuclear charge), the number of energy levels, and the shielding effect. For a row in the periodic table, the atomic number still increases (as it did for the groups), and thus the number of protons would increase. For a given period, however, we find that the outermost energy level does not change as the number of electrons increases. In period 2, for example, each additional electron goes into the second energy level, so the total number of energy levels does not go up. **Table 9.2** shows the electron configuration for the elements in period 2.

TABLE 9.2: Electron Configurations for Elements in Period 2

Element	Number of Protons	Electron Configuration
Lithium (Li)	3	$1s^2 2s^1$
Beryllium (Be)	4	$1s^2 2s^2$
Boron (B)	5	$1s^2 2s^2 2p^1$
Carbon (C)	6	$1s^2 2s^2 2p^2$
Nitrogen (N)	7	$1s^2 2s^2 2p^3$
Oxygen (O)	8	$1s^2 2s^2 2p^4$
Fluorine (F)	9	$1s^2 2s^2 2p^5$

Looking at the elements in period 2, the number of protons increases from three (for lithium) to nine (for fluorine). Therefore, the nuclear charge increases across a period. Meanwhile, the number of energy levels occupied by the electrons remains the same. How will this affect the radius? We know that every one of the elements in this period has two core electrons in the inner energy level ($n = 1$). The core electrons shield the outer electrons from the charge of the nucleus. Since the number of protons attracting the outer electrons increases while the shielding remains the same, the valence electrons are pulled closer to the nucleus, making the atom smaller.

Consider the elements lithium, beryllium, and fluorine from period 2. With lithium, the two core electrons will shield the one valence electron from three protons. Beryllium has four protons being shielded by the $1s^2$ electrons. For fluorine, there are nine protons and nine electrons. All three of these elements have the same core electrons: the $1s^2$ electrons. As the number of protons increases, the nuclear charge increases. With an increase in nuclear charge, there is an increase in the pull between the protons and the outer level, pulling the outer electrons toward the nucleus. The amount of shielding from the nucleus does not increase because the number of core electrons remains the same. The net result is that the atomic size decreases going across the row. In the graph below, the values are shown for the atomic radii for period 2.

Number of Protons vs. Atomic Radii

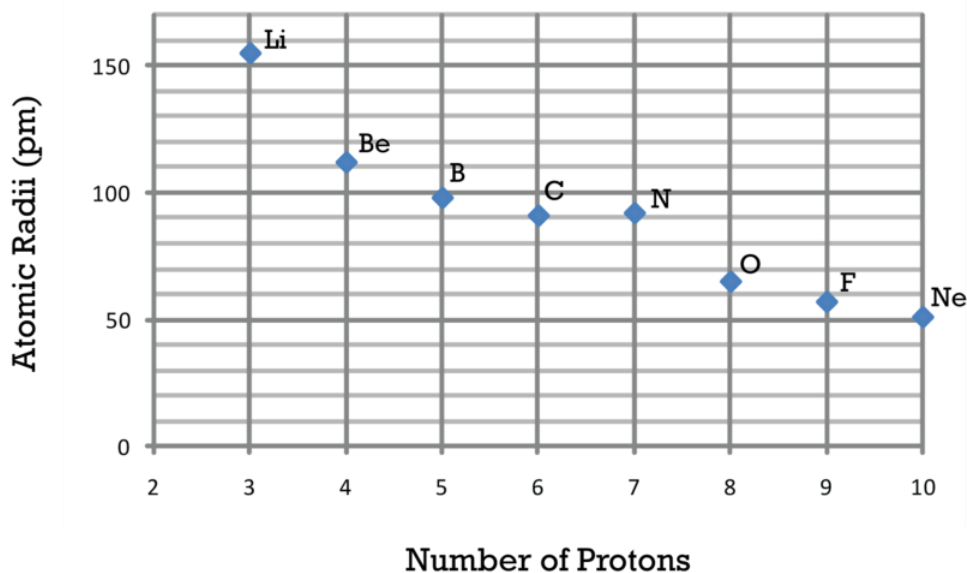

Let's add this new trend to the periodic table. In the diagram below, you will notice that the trend arrow for the period shows the atomic radii increase going from right to left, which is the equivalent to saying that the atomic radii decrease from left to right.

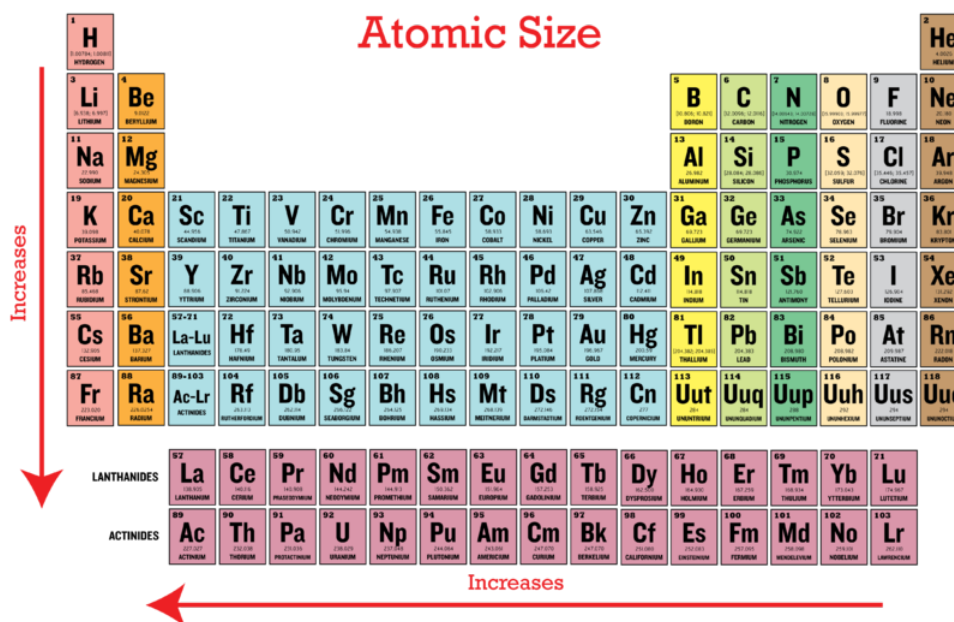

Considering these two trends, you will recognize that the largest atom, francium (atomic number 87), is at the bottom left-hand corner of the periodic table, while the smallest atom, helium (atomic number 2) is at the top right-hand corner of the table.

For an introduction to the electronic organization of the periodic table (1c), see <http://www.youtube.com/watch?v=35cWAXtHUGw> (4:20).

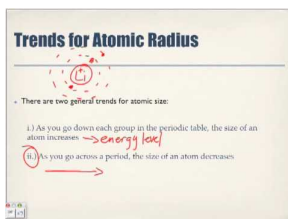
**MEDIA**

Click image to the left for more content.

Atomic Radii of Transition Elements

The general trend for atomic radii in the periodic table would look similar to that illustrated in the diagram below. The elements with the smallest atomic radii are found in the upper right; those with the largest atomic radii are found in the lower left.

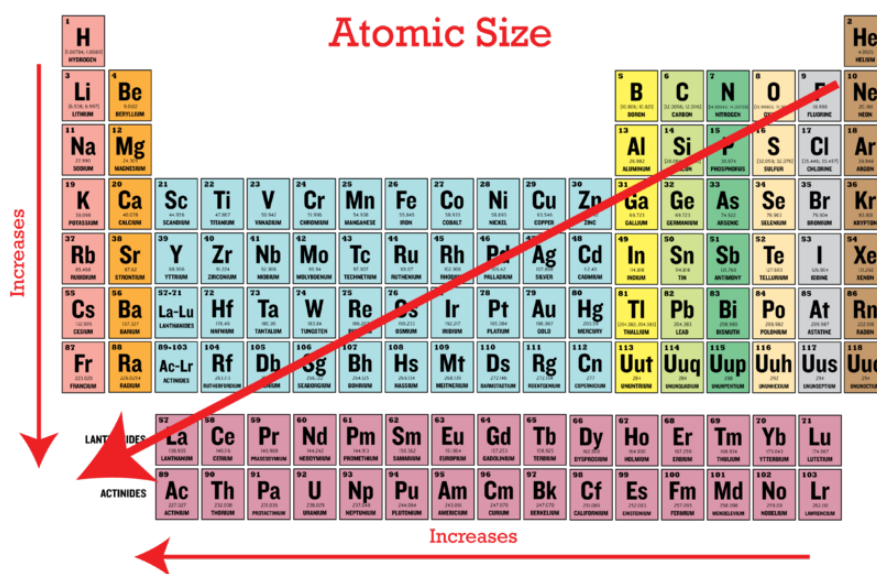

Until now, we have worked solely with the main group elements. Let's consider how three factors affecting atomic size affect transition metals. The first row of the transition metals all contain electrons in the $3d$ sublevel and are referred to as the $3d$ metals. **Table 9.3** shows the electron configuration for the ten elements in this row. The number of protons is increasing, so the nuclear charge is increasing.

TABLE 9.3: Electron Configuration for 3

Element	Number of Protons	Electron Configuration
Scandium (Sc)	21	$[\text{Ar}]3d^14s^2$
Titanium (Ti)	22	$[\text{Ar}]3d^24s^2$
Vanadium (V)	23	$[\text{Ar}]3d^34s^2$
Chromium (Cr)	24	$[\text{Ar}]3d^54s^1$
Manganese (Mn)	25	$[\text{Ar}]3d^54s^2$
Iron (Fe)	26	$[\text{Ar}]3d^64s^2$
Cobalt (Co)	27	$[\text{Ar}]3d^74s^2$
Nickel (Ni)	28	$[\text{Ar}]3d^84s^2$
Copper (Cu)	29	$[\text{Ar}]3d^{10}4s^1$
Zinc (Zn)	30	$[\text{Ar}]3d^{10}4s^2$

You may notice that some of these configurations are not what you would expect based on the information presented so far. Both chromium and copper have one of the $4s$ electrons moved to a $3d$ orbital. A simplified explanation for these unusual electron configurations is that the d sub-level is particularly stable when it is half-full (5 electrons) or completely full (10 electrons). Since the $4s$ and $3d$ orbitals are close in energy, this added stabilization is enough to change the location of one valence electron.

TABLE 9.4: Atomic Radii for 3d Metals

Element	Atomic Radii (pm)
Scandium (Sc)	164
Titanium (Ti)	147
Vanadium (V)	135
Chromium (Cr)	129
Manganese (Mn)	137
Iron (Fe)	126
Cobalt (Co)	125
Nickel (Ni)	125
Copper (Cu)	128
Zinc (Zn)	137

Table 9.4 lists the atomic radii for the first row of the transition metals. It can be seen from this table that the period trend in atomic radii is not followed as closely by the transition metals. Since we are adding electrons to the $3d$ orbitals, we are actually adding to the core electrons and *not* to the valence orbitals. Although the nuclear charge is going up, the shielding is also increasing with each added electron. Because of this, there is less atomic contraction throughout the transition metals.

The graph of the number of protons versus the atomic radii for the $3d$ metals is shown below. Compared to the same graph for the elements in period 2, the graph for transition metals shows the trend for atomic radii is not as straightforward.

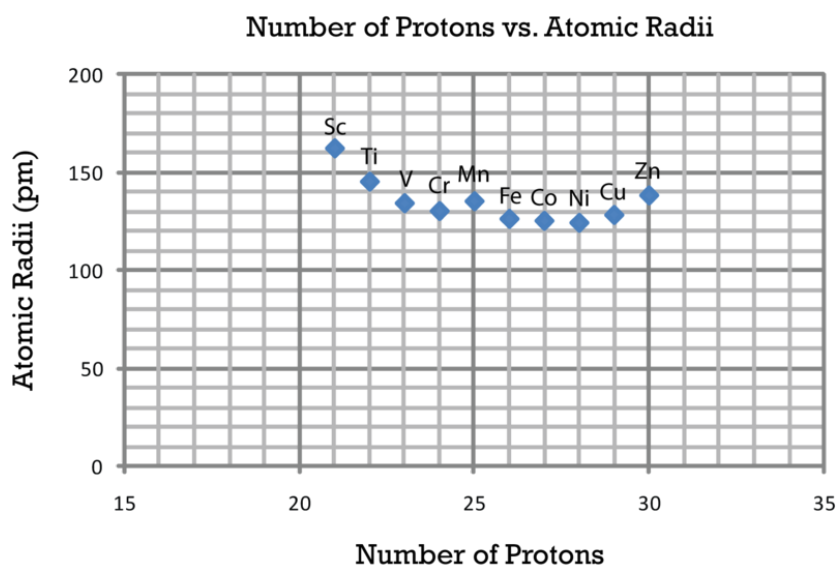

Lesson Summary

- Atomic size is the distance from the nucleus to the valence shell.

- Atomic size is difficult to measure because it has no definite boundary.
- Atomic radius is a more definite and measurable way of defining atomic size. It is half the distance from the center of one atom to the center of another atom in a homonuclear diatomic molecule.
- There are three factors that help in the prediction of the trends in the periodic table: number of protons in the nucleus, number of energy levels, and the shielding effect.
- The atomic radii increase from top to the bottom in any group.
- The atomic radii decrease from left to right across a period.
- This trend is not as systematic for the transition metals because other factors come into play.

Review Questions

1. Why is the atomic size considered to have “no definite boundary”?
2. How is atomic size measured?
 - a. using a spectrophotometer
 - b. using a tiny ruler (called a nano ruler)
 - c. indirectly
 - d. directly
3. Which of the following would be smaller: indium or gallium?
4. Which of the following would be smaller: potassium or cesium?
5. Which of the following would be smaller: titanium or polonium?
6. Explain why iodine is larger than bromine.
7. What are three factors that affect atomic size?
8. Which of the following would have the largest atomic radius?
 - a. Si
 - b. C
 - c. Sn
 - d. Pb
9. Which of the following would have the smallest atomic radius?
 - a. $1s^2 2s^2$
 - b. $1s^2 2s^2 2p^6 3s^1$
 - c. $1s^2$
 - d. $1s^1$
10. Arrange the following in order of increasing atomic radius: Tl, B, Ga, Al, In.
11. Arrange the following in order of increasing atomic radius: Ga, Sn, C.
12. Which of the following would be larger: Rb or Sn?
13. Which of the following would be larger: Ca or As?
14. Describe the trend for the atomic size of elements in a row in the periodic table.
15. Which of the following would have the largest atomic radius?
 - a. Sr
 - b. Sn
 - c. Rb
 - d. In
16. Which of the following would have the smallest atomic radius?
 - a. K
 - b. Kr
 - c. Ga

d. Ge

17. Arrange the following in order of decreasing atomic radius: Ba, Tl, Se, Bi, Cs.

9.3 Periodic Trends in Ionic Size

Lesson Objectives

The student will:

- explain what an ion is.
- describe how cations and anions are formed.
- describe the factors that determine the trend in ionic size.
- describe the trend in ionic size for elements.
- use the general trends to predict the relative sizes of ions.

Vocabulary

- anion
- cation
- ion

Introduction

An atom is electrically neutral, which means that the number of protons is equal to the number of electrons. In chemical reactions, however, atoms can gain or lose electrons. This results in the formation of an ion. An **ion** is an atom with a positive or negative charge.

Atoms and Ions

Atoms of metallic elements tend to form positive ions by losing one or more electrons. A positive ion is called a **cation** (pronounced CAT-ion) and has fewer electrons than an electrically neutral atom. For example, an atom of sodium has eleven protons and eleven electrons. Its electron configuration is $[\text{Ne}]3s^1$. Sodium has one valence electron surrounding a stable core of ten electrons. In chemical reactions, a sodium atom tends to lose its one valence electron to become a sodium cation. Because this sodium ion has eleven protons and only ten electrons, it has a net charge of +1. An atom that loses two electrons will become an ion with a charge of +2, and an atom that loses three electrons will become an ion with a charge of +3.

Atoms of nonmetallic elements tend to form negative ions by gaining one or more electrons. A negative ion is called an **anion** (pronounced AN-ion). For example, an atom of fluorine has seventeen protons and seventeen electrons. Its electron configuration is $1s^2 2s^2 2p^5$, and it has seven valence electrons. In chemical reactions, a fluorine atom tends to gain one valence electron, becoming a fluoride anion. (Notice that the name of anions typically end in “-ide.”) Because the fluoride ion has seventeen positive protons and eighteen negative electrons, it has a net charge of -1.

An atom that gains two electrons will become an ion with a charge of -2 , and an atom that gains three electrons will become an ion with a charge of -3 .

Group and Period Trends in Ionic Size

Cations are smaller than the atoms from which they are formed. The loss of outer shell electrons results in increased attraction between the nucleus and the remaining electrons. This results in less electron-electron repulsion and allows the nucleus and the electrons to come closer together. When compared to a neutral atom of sodium, Na, a sodium cation, symbolized by Na^+ , has a smaller size.

Anions are larger than the atoms from which they are formed. The gain of outer shell electrons results in decreased attraction between the nucleus and the remaining electrons, and electron-electron repulsion forces them to spread apart. When compared to a neutral atom of fluorine, F, a fluoride anion, symbolized by F^- , has a larger size.

If we examine the ionic sizes of just the metals in the main group, we will find that the trends are the same as the trends in atomic sizes for the neutral elements. All the elements for each group of metals lose the same number of electrons, which means that the ionic sizes will be primarily affected by the number of energy levels in the electron cloud. Since the number of energy levels still increases from top to bottom, the ionic size also increases down a group of elements in the periodic table. For similar reasons, the trend across a period is the same for both ions and neutral atoms. All the metal elements in a given period will lose their outer shell electrons but still have the same number of core electrons. As a result, the nuclear charge increases from left to right, while the number of core electrons remains the same. This means that the ion size will decrease from left to right across a period.

Nonmetals also see the same trends in size as the neutral elements. The negative ions increase in size as you move down a group and decrease in size as you move from left to right across a period. In other words, as you go from top to bottom down a group or left to right across a period, the ionic size decreases *as long as* you are comparing all metals or all nonmetals. Between the metals and the nonmetals, the ionic size increases because you are switching from cations, which lose electrons, to anions, which gain electrons.

Lesson Summary

- In chemical reactions, atoms can gain or lose electrons. This results in the formation of an ion. An ion is basically an atom with a positive or negative charge.
- Atoms of metallic elements tend to form positive ions (cations) by losing one or more electrons.
- Atoms of nonmetallic elements tend to form negative ions (anions) by gaining one or more electrons.
- Cations are smaller than the atoms from which they are formed.
- Anions are larger than the atoms from which they were formed.
- Ionic size increases from top to bottom down a group of elements in the periodic table.
- From left to right across a period, the ionic size decreases as long as you are comparing all metals or all nonmetals. Between the metals and nonmetals, the ionic size increases as you switch from cations to anions.

Review Questions

1. How is the size of a cation different from the size of the atom from which it was formed? Why?
2. How is the size of an anion different from the size of the atom from which it was formed? Why?
3. Mg^{2+} has the same number of electrons as F^- (they are said to be isoelectric). Which ion is larger and why?
4. Which of the following has the smallest ionic radius?

- a. O^{2-}
 - b. S^{2-}
 - c. Mg^{2+}
 - d. Ca^{2+}
5. Which of the following has the largest ionic radius?
- a. Ba^{2+}
 - b. Cs^+
 - c. I^-
 - d. Te^{2-}

9.4 Periodic Trends in Ionization Energy

Lesson Objectives

The student will:

- define ionization energy.
- describe the trends that exist in the periodic table for ionization energy.
- use the general trends to predict the relative ionization energies of atoms.

Introduction

Atoms are capable of forming ions by either losing or gaining electrons. Since the electrons are attracted to the positively charged nucleus, energy is needed to pull the electron away from the nucleus. In this lesson, we will gain an understanding of the energy required to remove an electron and recognize its trend on the periodic table.

Vocabulary

- effective nuclear charge
- ionization energy

Ionization Energy Defined

Consider lithium, which has an electron configuration of $1s^22s^1$ and has one electron in its outermost energy level. In order to remove this electron, energy must be added to the system. Look at the equation below:

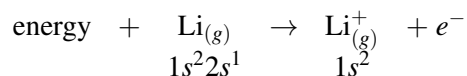

With the addition of energy, a lithium atom can lose one electron and form a lithium ion. This energy is known as the ionization energy. The **ionization energy** is the energy required to remove the most loosely held electron from a gaseous atom or ion. The higher the value of the ionization energy, the harder it is to remove that electron. In the equation above, the subscript “g” indicates that the element is in the form of a gas. The definition for ionization energy specifies “in the gaseous phase” because when the atom or ion is in the liquid or solid phases, other factors are involved. The general equation for the ionization energy is as follows.

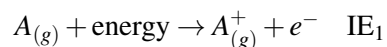

If a second electron is to be removed from an atom, the general equation for the ionization energy is as follows:

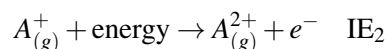

After the first electron is removed, there are a greater number of protons than electrons. As a result, when a second electron is being removed, the energy required for the second ionization (IE_2) will be greater than the energy required for the first ionization (IE_1). In other words, $\text{IE}_1 < \text{IE}_2 < \text{IE}_3 < \text{IE}_4$.

Group and Period Trends in Ionization Energy

We can see a trend when we look at the ionization energies for the elements in period 2. **Table 9.5** summarizes the electron configuration and the ionization energies for the elements in the second period.

TABLE 9.5: First Ionization Energies for Period 2 Main Group Elements

Element	Electron Configuration	First Ionization Energy, IE_1
Lithium (Li)	$[\text{He}]2s^1$	520 kJ/mol
Beryllium (Be)	$[\text{He}]2s^2$	899 kJ/mol
Boron (B)	$[\text{He}]2s^22p^1$	801 kJ/mol
Carbon (C)	$[\text{He}]2s^22p^2$	1086 kJ/mol
Nitrogen (N)	$[\text{He}]2s^22p^3$	1400 kJ/mol
Oxygen (O)	$[\text{He}]2s^22p^4$	1314 kJ/mol
Fluorine (F)	$[\text{He}]2s^22p^5$	1680 kJ/mol

We can see that as we move across the period from left to right, in general the ionization energy increases. At the beginning of the period with the alkali metals and the alkaline earth metals, losing one or two electrons allows these atoms to become ions.

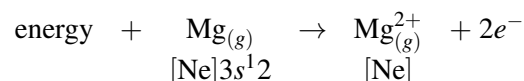
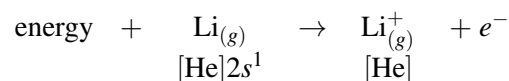

As we move across the period, the atoms become smaller, which causes the nucleus to have greater attraction for the valence electrons. Therefore, the electrons are more difficult to remove.

A similar trend can be seen for the elements within a family. **Table 9.6** shows the electron configuration and the first ionization energies (IE_1) for some of the elements in the first group, the alkali metals.

TABLE 9.6: First Ionization Energies for Some Period 1 Elements

Element	Electron Configuration	First Ionization Energy, IE_1
Lithium (Li)	$[\text{He}]2s^1$	520 kJ/mol
Sodium (Na)	$[\text{Ne}]3s^1$	495.5 kJ/mol
Potassium (K)	$[\text{Ar}]4s^1$	418.7 kJ/mol

By comparing the electron configurations of lithium to potassium, we know that the valence electron is further away from the nucleus. We know this because the n value is larger, which means that the energy level holding the valence electron is larger. It is easier to remove the most loosely held electron when the electron is further away from the nucleus, because the attractive pull between the nucleus and an electron decreases as the distance between the two increases. Therefore, IE_1 for potassium is less than IE_1 for lithium.

Why does the ionization energy increase going across a period? It has to do with two factors. One factor is that the atomic size decreases. The second factor is that the effective nuclear charge increases. The **effective nuclear charge** is the charge experienced by a specific electron within an atom. Recall that the nuclear charge was used to describe why the atomic size decreased going across a period. **Table 9.7** shows the effective nuclear charge along with the ionization energy for the elements in period 2.

TABLE 9.7: Effective Nuclear Charge for Period 2 Main Group Elements

Element	Electron Configuration	Number of Protons	Number of Core Electrons	Effective Nuclear Charge	Ionization Energy
Lithium (Li)	[He]2s ¹	3	2	1	520 kJ/mol
Beryllium (Be)	[He]2s ²	4	2	2	899 kJ/mol
Boron (B)	[He]2s ² 2p ¹	5	2	3	801 kJ/mol
Carbon (C)	[He]2s ² 2p ²	6	2	4	1086 kJ/mol
Nitrogen (N)	[He]2s ² 2p ³	7	2	5	1400 kJ/mol
Oxygen (O)	[He]2s ² 2p ⁴	8	2	6	1314 kJ/mol
Fluorine (F)	[He]2s ² 2p ⁵	9	2	7	1680 kJ/mol

The electrons that are shielding the nuclear charge are the core electrons, which are the 1s² electrons for period 2. The effective nuclear charge is approximately the difference between the total nuclear charge and the number of core electrons. Notice that as the effective nuclear charge increases, the ionization energy also increases. Overall, the general trend for ionization energy is summarized in the diagram below.

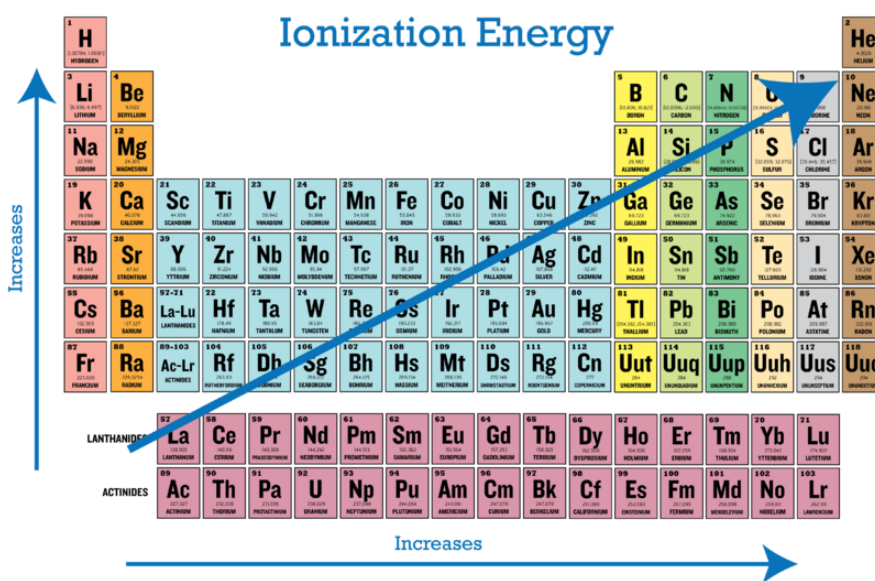

Example:

What would be the effective nuclear charge for chlorine? Would you predict the ionization energy to be higher or lower than the ionization energy for fluorine?

Solution:

Chlorine has the electron configuration: Cl = [Ne]3s²3p⁵. The effective nuclear charge is 7, which is the same as the nuclear charge for fluorine. Predicting the ionization energy with just this information would be difficult. The atomic size, however, is larger for chlorine than it is for fluorine because chlorine has three energy levels (chlorine is in period 3). Now we can conclude that the ionization energy for chlorine should be lower than that of fluorine

because the electron would be easier to pull off when it is further away from the nucleus. (Indeed, the value for the first ionization energy of chlorine is 1251 kJ/mol, compared to 1680 kJ/mol for fluorine.)

A few anomalies exist with respect to the ionization energy trends. Going across a period, there are two ways in which the ionization energy may be affected by the electron configuration. When we look at period 3, we can see that there is an anomaly as we move from the 3s sublevels to the 3p sublevel. The table below shows the electron configurations and first ionization energy for the main group elements in period 3.

Element	Electron Configuration	Ionization Energy
Sodium (Na)	$1s^2 2s^2 2p^6 3s^1$	495.9 kJ/mol
Magnesium (Mg)	$1s^2 2s^2 2p^6 3s^2$	738.1 kJ/mol
Aluminum (Al)	$1s^2 2s^2 2p^6 3s^2 3p^1$	577.9 kJ/mol
Silicon (Si)	$1s^2 2s^2 2p^6 3s^2 3p^2$	786.3 kJ/mol
Phosphorus (P)	$1s^2 2s^2 2p^6 3s^2 3p^3$	1012 kJ/mol
Sulfur (S)	$1s^2 2s^2 2p^6 3s^2 3p^4$	999.5 kJ/mol
Chlorine (Cl)	$1s^2 2s^2 2p^6 3s^2 3p^5$	1251 kJ/mol
Argon (Ar)	$1s^2 2s^2 2p^6 3s^2 3p^6$	1520 kJ/mol

In the table, we see that when we compare magnesium to aluminum, the IE_1 decreases instead of increases. Why is this? Magnesium has its outermost electrons in the 3s sub-level. The aluminum atom has its outermost electron in the 3p sublevel. Since *p* electrons have just slightly more energy than *s* electrons, it takes a little less energy to remove that electron from aluminum. One other factor is that the electrons in $3s^2$ shield the electron in $3p^1$. These two factors allow the IE_1 for aluminum to be less than IE_1 for magnesium.

When we look again at the table, we can see that the ionization energy for nitrogen also does not follow the general trend.

Element	Electron Configuration	Ionization Energy
Lithium (Li)	$[\text{He}] 2s^1$	520 kJ/mol
Beryllium (Be)	$[\text{He}] 2s^2$	899 kJ/mol
Boron (B)	$[\text{He}] 2s^2 2p^1$	801 kJ/mol
Carbon (C)	$[\text{He}] 2s^2 2p^2$	1086 kJ/mol
Nitrogen (N)	$[\text{He}] 2s^2 2p^3$	1400 kJ/mol
Oxygen (O)	$[\text{He}] 2s^2 2p^4$	1314 kJ/mol
Fluorine (F)	$[\text{He}] 2s^2 2p^5$	1680 kJ/mol
Neon (Ne)	$[\text{He}] 2s^2 2p^6$	2081 kJ/mol

While nitrogen has one electron occupying each of the three *p* orbitals in the second sub-level, oxygen has an additional electron in one of the three 2*p* orbitals. The presence of two electrons in an orbital lead to greater

electron-electron repulsion experienced by these $2p$ electrons, which lowers the amount of energy needed to remove one of these electrons. Therefore, IE_1 for oxygen is less than that for nitrogen.

This video discusses the ionization energy trends in the periodic table (1c): <http://www.youtube.com/watch?v=xE9YOBXdTS0> (9:25).

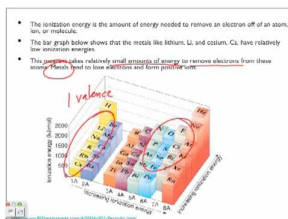

MEDIA

Click image to the left for more content.

Lesson Summary

- Ionization energy is the energy required to remove the most loosely held electron from a gaseous atom or ion. Ionization energy generally increases across a period and decreases down a group.
- Once one electron has been removed, a second electron can be removed, but $IE_1 < IE_2$. If a third electron is removed, $IE_1 < IE_2 < IE_3$, and so on.
- The effective nuclear charge is the charge of the nucleus felt by the valence electrons.
- The effective nuclear charge and the atomic size help explain the trend of ionization energy. Going down a group, the atomic size gets larger and the electrons can be more readily removed. Therefore, ionization energy decreases down a group. Going across a period, both the effective nuclear charge and the ionization energy increases, because the electrons are harder to remove.

Review Questions

1. Define ionization energy and write the general ionization equation.
2. Which of the following would have the largest ionization energy?
 - a. Na
 - b. Al
 - c. H
 - d. He
3. Which of the following would have the smallest ionization energy?
 - a. K
 - b. P
 - c. S
 - d. Ca
4. Place the following elements in order of increasing ionization energy: Na, O, Mg, Ne, K.
5. Place the following elements in order of decreasing ionization energy: N, Si, P, Mg, He.
6. Using experimental data, the first ionization energy for an element was found to be 600 kJ/mol. The second ionization energy was found to be 1800 kJ/mol. The third, fourth, and fifth ionization energies were found to be, respectively, 2700 kJ/mol, 11,600 kJ/mol, and 15,000 kJ/mol. To which family of elements does this element belong? Explain.
7. Using electron configurations and your understanding of ionization energy, which would you predict to have a higher second ionization energy: Na or Mg?

8. Comparing the first ionization energies of Ca and Mg,
 - a. calcium has a higher ionization energy because its radius is smaller.
 - b. magnesium has a higher ionization energy because its radius is smaller.
 - c. calcium has a higher ionization energy because its outermost sub-energy level is full.
 - d. magnesium has a higher ionization energy because its outermost sub-energy level is full.
 - e. they have the same ionization energy because they have the same number of valence electrons.
9. Comparing the first ionization energies of Be and B,
 - a. beryllium has a higher ionization energy because its radius is smaller.
 - b. boron has a higher ionization energy because its radius is smaller.
 - c. beryllium has a higher ionization energy because its outermost sub-energy level is full.
 - d. boron has a higher ionization energy because its outermost sub-energy level is full.
 - e. they have the same ionization energy because boron only has one extra valence electron.

9.5 Periodic Trends in Electronegativity

Lesson Objectives

The student will:

- define electronegativity.
- describe the trends that exist in the periodic table for electronegativity.
- use the general trends to predict the relative electronegativities of atoms.

Vocabulary

- electronegativity

Introduction

Around 1935, the American chemist Linus Pauling developed a scale to describe the attraction an element has for electrons in a chemical bond. In this lesson, we will gain an understanding of this concept and recognize its trend on the periodic table.

Electronegativity Defined

In a molecule, some electrons are shared between the atoms making up the molecule. The ability of an atom in a molecule to attract shared electrons is called **electronegativity**. The higher the electronegativity of an atom, the greater its ability to attract shared electrons. The electronegativity of atoms has been defined in several ways. One method that is widely accepted is that developed by Linus Pauling.

On the Pauling scale, shown below, fluorine is the most electronegative element with an electronegativity of close to 4.0, and cesium and francium are the least electronegative with electronegativities of around 0.7.

Pauling Electronegativity Values

1 H 2.20																	5 B 2.04	6 C 2.55	7 N 3.04	8 O 3.44	9 F 3.98	
3 Li 0.98	4 Be 1.57																	13 Al 1.61	14 Si 1.90	15 P 2.19	16 S 2.58	17 Cl 3.16
11 Na 0.93	12 Mg 1.31	19 K 0.82	20 Ca 1.00	21 Sc 1.36	22 Ti 1.54	23 V 1.63	24 Cr 1.66	25 Mn 1.55	26 Fe 1.83	27 Co 1.88	28 Ni 1.91	29 Cu 1.90	30 Zn 1.65	31 Ga 1.81	32 Ge 2.01	33 As 2.18	34 Se 2.55	35 Br 2.96				
37 Rb 0.82	38 Sr 0.95	39 Y 1.22	40 Zr 1.33	41 Nb 1.6	42 Mo 2.16	43 Tc 1.9	44 Ru 2.2	45 Rh 2.28	46 Pd 2.20	47 Ag 1.93	48 Cd 1.69	49 In 1.78	50 Sn 1.96	51 Sb 2.05	52 Te 2.1	53 I 2.66						
55 Cs 0.79	56 Ba 0.89	57 La 1.1	72 Hf 1.3	73 Ta 1.5	74 W 2.36	75 Re 1.9	76 Os 2.2	77 Ir 2.20	78 Pt 2.28	79 Au 2.54	80 Hg 2.00	81 Tl 1.62	82 Pb 2.33	83 Bi 2.02	84 Po 2.0	85 At 2.2						
87 Fr 0.7	88 Ra 0.9																					

Group and Period Trends in Electronegativity

The electronegativity of atoms increases as you move from left to right across a period in the periodic table. This is because as you go from left to right across a period, the nuclear charge is increasing faster than the electron shielding, so the attraction that the atoms have for the valence electrons increases.

The electronegativity of atoms decreases as you move from top to bottom down a group in the periodic table. This is because as you go from top to bottom down a group, the atoms of each element have an increasing number of energy levels. The electrons in a bond are thus farther away from the nucleus and are held less tightly.

Atoms with low ionization energies have low electronegativities because their nuclei do not have a strong attraction for electrons. Atoms with high ionization energies have high electronegativities because the nucleus has a strong attraction for electrons.

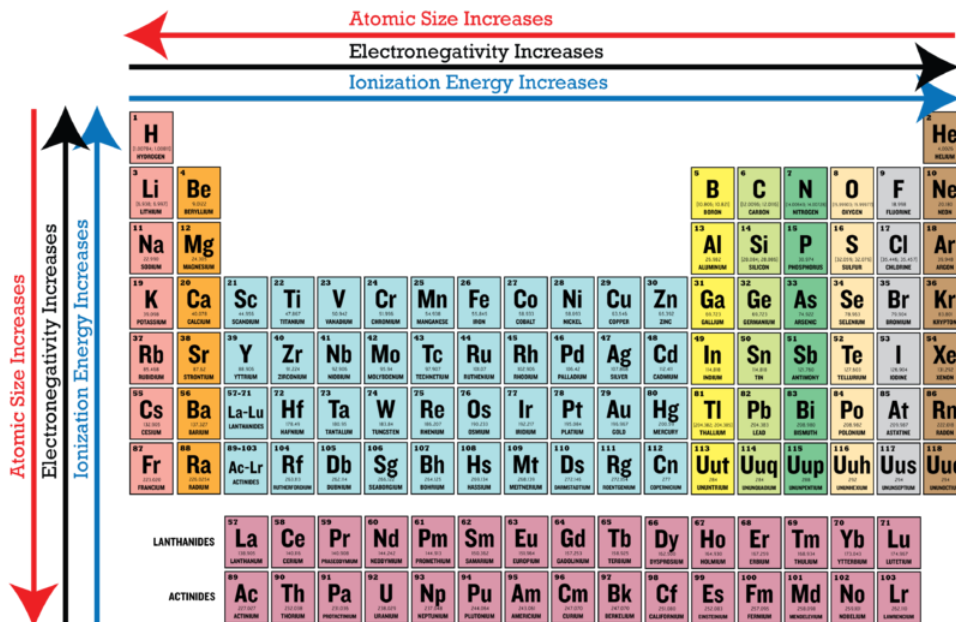

Here is another video that describes ionization energy trends in the periodic table (**1c**): <http://www.youtube.com/watch?v=q3AiM1BYX-c> (9:39).

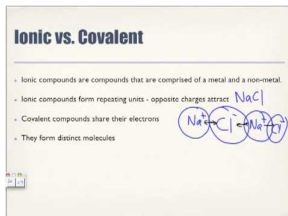
**MEDIA**

Click image to the left for more content.

Lesson Summary

- American chemist Linus Pauling developed the electronegativity scale to describe the attraction an element has for electrons in a chemical bond.
- The higher the electronegativity of an atom, the greater its ability to attract shared electrons.
- The electronegativity of atoms increases as you move from left to right across a period in the periodic table.
- The electronegativity of atoms decreases as you move from top to bottom down a group in the periodic table.

Further Reading / Supplemental Links

A series of selectable videos that show the properties and discuss the bonding of various elements.

- <http://www.periodicvideos.com/#>

Review Questions

1. Define electronegativity.
2. Choose the element in each pair that has the lower electronegativity.
 - a. Li or N
 - b. Cl or Na
 - c. Ca or K
 - d. Mg or F
3. Which of the following will have the largest electronegativity?
 - a. Se
 - b. F
 - c. Ne
 - d. Br
4. Which of the following will have the smallest electronegativity?
 - a. Na
 - b. Ne
 - c. Al
 - d. Rb

5. Describe the general trend for electronegativity in period 2.

9.6 Periodic Trends in Electron Affinity

Lesson Objectives

The student will:

- define electron affinity.
- describe the trends for electron affinity in the periodic table.

Vocabulary

- electron affinity

Introduction

We have talked about atomic structure, electronic configurations, size of atoms and ions, ionization energy, and electronegativity. The final periodic trend that we will examine is how atoms gain electrons.

Electron Affinity Defined

Atoms can gain or lose electrons. When an atom gains an electron, energy is given off and is known as the electron affinity. **Electron affinity** is defined as the energy released when an electron is added to a gaseous atom or ion.

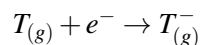

For most elements, the addition of an electron to a gaseous atom releases potential energy.



Group and Period Trends in Electron Affinity

Let's look at the electron configurations of a few elements and the trend that develops within groups and periods. **Table 9.8** shows the electron affinities for the halogen family.

TABLE 9.8: Electron Affinities for Group 7A

Element	Electron Configuration	Electron Affinity, kJ/mol
Fluorine, F	[He]2s ² 2p ⁵	-328
Chlorine, Cl	[Ne]3s ² 3p ⁵	-349
Bromine, Br	[Ar]4s ² 4p ⁵	-325
Iodine, I	[Kr]5s ² 5p ⁵	-295

Going down a group, the electron affinity generally decreases because of the increase in size of the atoms. Remember that within a family, atoms located lower on the periodic table are larger because there are more filled energy levels. When an electron is added to a large atom, less energy is released because the electron cannot move as close to the nucleus as it can in a smaller atom. Therefore, as the atoms in a family get larger, the electron affinity gets smaller.

There are exceptions to this trend, especially when comparing the electron affinity of smaller atoms. In **Table 9.8**, the electron affinity for fluorine is less than that for chlorine. This phenomenon is observed in other families as well. The electron affinity of all the elements in the second period is less than the the electron affinity of the elements in the third period. For instance, the electron affinity for oxygen is less than the electron affinity for sulfur. This is most likely due to the fact that the elements in the second period have such small electron clouds ($n = 2$) that electron repulsion of these elements is greater than that of the rest of the family.

Overall, each row in the periodic table shows a general trend similar to the one below.

Electron Affinities for Period 4 Main Group Elements		
Element	Electron Configuration	Electron Affinity
Potassium (K)	[Ar] 4s ¹	-48 kJ/mol
Calcium (Ca)	[Ar] 4s ²	-2.4 kJ/mol
Gallium (Ga)	[Ar] 4s ² 4p ¹	-29 kJ/mol
Germanium (Ge)	[Ar] 4s ² 4p ²	-118 kJ/mol
Arsenic (As)	[Ar] 4s ² 4p ³	-77 kJ/mol
Selenium (Se)	[Ar] 4s ² 4p ⁴	-195 kJ/mol
Bromine (Br)	[Ar] 4s ² 4p ⁵	-325 kJ/mol
Krypton (Kr)	[Ar] 4s ² 4p ⁶	0 kJ/mol

The general trend in the electron affinity for atoms is almost the same as the trend for ionization energy. This is because both electron affinity and ionization energy are highly related to atomic size. Large atoms have low ionization energy and low electron affinity. Therefore, they tend to lose electrons. In general, the opposite is true for small atoms. Since they are small, they have high ionization energies and high electron affinities. Therefore, the small atoms tend to gain electrons. The major exception to this rule is the noble gases. Noble gases follow the general trend for ionization energies, but do not follow the general trend for electron affinities. Even though the noble gases are small atoms, their outer energy levels are completely filled with electrons. Any added electron cannot enter their outer most energy level and would have to be the first electron in a new (larger) energy level. This causes the noble gases to have essentially zero electron affinity.

When atoms become ions, the process involves either releasing energy (through electron affinity) or absorbing energy (ionization energy). Therefore, the atoms that require a large amount of energy to release an electron will most likely be the atoms that give off the most energy while accepting an electron. In other words, nonmetals will gain electrons

most easily since they have large electron affinities and large ionization energies. Metals will lose electrons since they have the low ionization energies and low electron affinities.

Lesson Summary

- Electron affinity is the energy released when an electron is added to a gaseous atom or ion.
- Electron affinity generally decreases going down a group and increases left to right across a period.
- Nonmetals tend to have the highest electron affinities.

Further Reading / Supplemental Links

This video shows the relationships between atomic size, ionization energy, and electron affinity.

- <http://www.youtube.com/watch?v=iCwYjpl8eeY&feature=channel>

This pdf document reviews the causes and relationships of the trends in atomic size, ionization energy, electronegativity, and electron affinity.

- <http://www.oakland.k12.mi.us/Portals/0/Learning/PeriodicTable.pdf>

Review Questions

1. Define electron affinity and write an example equation.
2. Choose the element in each pair that has the lower electron affinity.
 - a. Li or N
 - b. Cl or Na
 - c. Ca or K
 - d. Mg or F
3. Why is the electron affinity for calcium higher than that of potassium?
4. Which of the following will have the largest electron affinity?
 - a. Se
 - b. F
 - c. Ne
 - d. Br
5. Which of the following will have the smallest electron affinity?
 - a. Na
 - b. Ne
 - c. Al
 - d. Rb
6. Place the following elements in order of increasing electron affinity: Tl, Br, S, K, Al.
7. Describe the general trend for electron affinities in period 2.
8. Why does sulfur have a greater electron affinity than phosphorus does?

All images, unless otherwise stated, are created by the CK-12 Foundation and are under the Creative Commons license CC-BY-NC-SA.

CHAPTER **10** Ionic Bonds and Formulas

Chapter Outline

- 10.1 IONS AND ION FORMATION
 - 10.2 IONIC COMPOUNDS
 - 10.3 WRITING IONIC FORMULAS
 - 10.4 NAMING IONIC COMPOUNDS
 - 10.5 REFERENCES
-

10.1 Ions and Ion Formation

Lesson Objectives

The student will:

- explain why atoms form ions.
- identify the atoms most likely to form positive ions and the atoms most likely to form negative ions.
- given the symbol of a main group element, indicate the most likely number of electrons the atom will gain or lose.
- predict the charge on ions from the electron affinity, ionization energies, and electron configuration of the atom.
- describe what polyatomic ions are.
- given the formula of a polyatomic ion, name it, and vice versa.

Vocabulary

- polyatomic ion

Introduction

Before students begin the study of chemistry, they might think that the most stable form for an element is that of a neutral atom. As it happens, that particular idea is not true. There are approximately 190,000,000,000,000,000 kilotons of sodium in the earth, yet almost none of that is in the form of sodium atoms. Sodium reacts readily with oxygen in the air and explosively with water, so it must be stored under kerosene or mineral oil to keep it away from air and water. Essentially all of the sodium on earth that exists in its elemental form is man-made.

If those 1.9×10^{17} kilotons of sodium are not in the form of atoms, in what form are they? Virtually all the sodium on Earth is in the form of sodium ions, Na^+ . The oceans of the earth contain a large amount of sodium ions in the form of dissolved salt, many minerals have sodium ions as one component, and animal life forms require a certain amount of sodium ions in their systems to regulate blood and bodily fluids, facilitate nerve function, and aid in metabolism. If sodium ions and not sodium atoms can be readily found in nature, it seems reasonable to suggest that ions are chemically more stable than atoms. By *chemically stable*, we mean less likely to undergo chemical change.

One of the major tendencies that causes change to occur in chemistry (and other sciences as well) is the tendency for matter to alter its condition in order to achieve lower potential energy. You can place objects in positions of higher potential energy, such as by stretching a rubber band or pushing the south poles of two magnets together, but if you want them to remain that way, you must hold them there. If you release the objects, they will move toward lower potential energy.

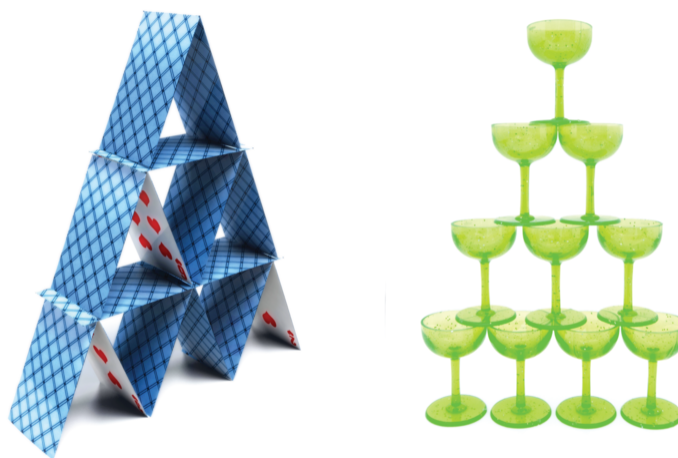

As another example, you can build a house of playing cards or a pyramid of champagne glasses that will remain balanced (like the ones pictured above), provided no one wiggles the table. If someone does wiggle the table, the structures will fall to lower potential energy. In the case of atoms and molecules, the particles themselves have constant random motion. For atoms and molecules, this molecular motion is like constantly shaking the table.

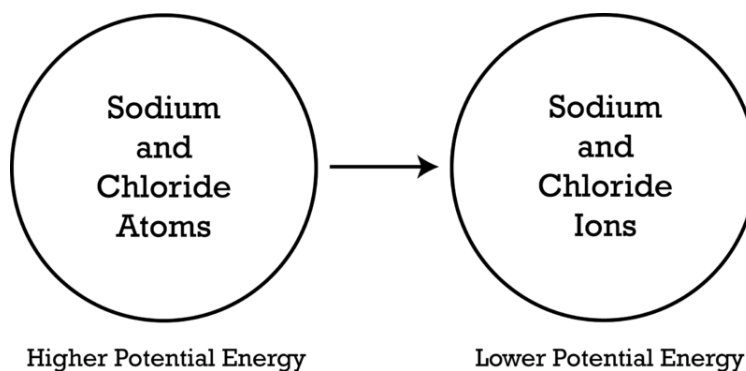

Comparing a system that contains sodium atoms and chlorine atoms to a system that contains sodium ions and chloride ions, we find that the system containing the ions has lower potential energy. This is due to the random motion of the atoms and molecules, which causes collisions between the particles. These collisions are adequate to initiate the change to lower potential energy.

Ion Formation

Recall that an atom becomes an ion when it gains or loses electrons. Cations are positively charged ions that form when an atom loses electrons, and anions are negatively charged ions that form when an atom gains electrons. Ionization energies and electron affinities control which atoms gain electrons, which atoms lose electrons, and how many electrons an atom gains or loses. At this point, you should already know the general trends of ionization energy and electron affinity in the periodic table (refer to the chapter “Chemical Periodicity” for more details about these trends).

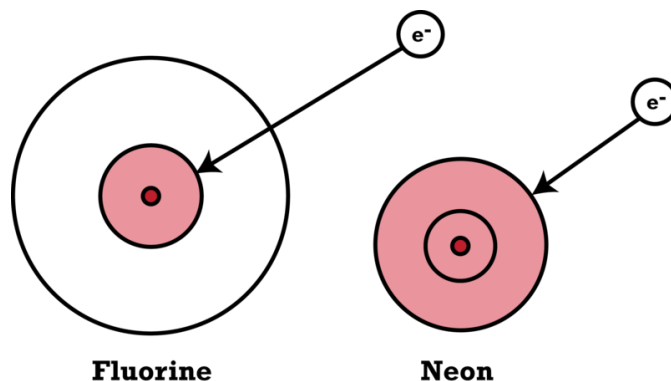

An atom's attraction for adding electrons is related to how close the new electron can approach the nucleus of the atom. In the case of fluorine (electron configuration $1s^2 2s^2 2p^5$), the first energy level is full but the second one is not full. This allows an approaching electron to penetrate the second energy level and approach the first energy level and the nucleus. In the case of neon, both the first energy level and the second energy levels are full. This means that an approaching electron cannot penetrate either energy level. Looking at these situations sketched in the figure above, it is apparent that the approaching electron can get much closer to the nucleus of fluorine than it can with neon. Neon, in fact, has zero electron affinity. In comparison, the electron affinity of fluorine is -328 kJ/mole.

Spontaneous changes occur when accompanied by a decrease in potential energy. Without the decrease in potential energy, there is no reason for the activity to occur. When fluorine takes on an extra electron, it releases energy and moves toward lower potential energy. If neon took on an extra electron, there would be no decrease in potential energy, which is why neon does not spontaneously attract additional electrons. In comparison, the electron affinity of sodium is $+52.8$ kJ/mole. This means energy must be put in to force a sodium atom to accept an extra electron. Forcing sodium to take on an extra electron is not a spontaneous change because it requires an increase in potential energy.

Metals and Nonmetals

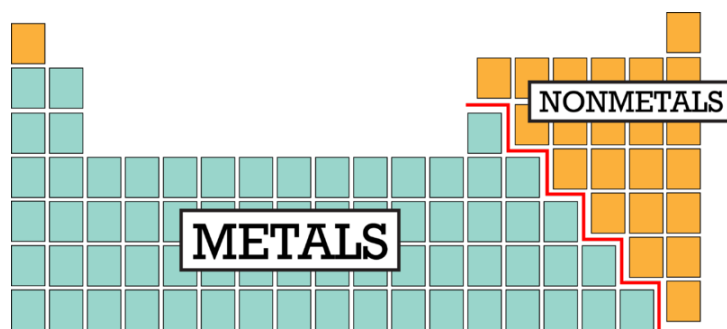

Metals, the atoms found on the left side of the table, have low ionization energies and low electron affinities. Therefore, they will lose electrons fairly readily, but they tend not to gain electrons. The atoms designated as nonmetals, the ones on the right side of the table, have high ionization energies and high electron affinities. Thus, they will not lose electrons, but they will gain electrons. The noble gases have high ionization energies and low electron affinities, so they will neither gain nor lose electrons. The noble gases were called inert gases (because they wouldn't react with anything) until 1962, when Neil Bartlett used very high temperature and pressure to force xenon and fluorine to combine. With a few exceptions, metals tend to lose electrons and become cations, while nonmetals tend to gain electrons and become anions. Noble gases tend to do neither.

In many cases, all that is needed to transfer one or more electrons from a metallic atom to a nonmetallic one is for the atoms bump into each other during their normal random motion. This collision at room temperature is sufficient to remove an electron from an atom with low ionization energy, and that electron will immediately be absorbed by an

atom with high electron affinity. Adding the electron to the nonmetal causes a release of energy to the surroundings. The energy release that occurs by adding this electron to an atom with high electron affinity is greater than the energy release that would occur if this electron returned to the atom from which it came. Hence, this electron transfer is accompanied by a lowering of potential energy. This complete transfer of electrons produces positive and negative ions, which then stick together due to electrostatic attraction.

Numbers of Electrons Gained or Lost

So far, we have been considering the ionization energy of atoms when one electron is removed. It is possible to continue removing electrons after the first one is gone. When a second electron is removed, the energy required is called the second ionization energy. The energy required to remove a third electron is called the third ionization energy, and so on. **Table 10.1** shows the first four ionization energies for the atoms sodium, magnesium, and aluminum. As a reminder, the electron configurations for these atoms are:

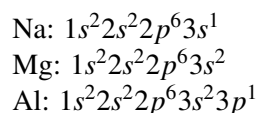
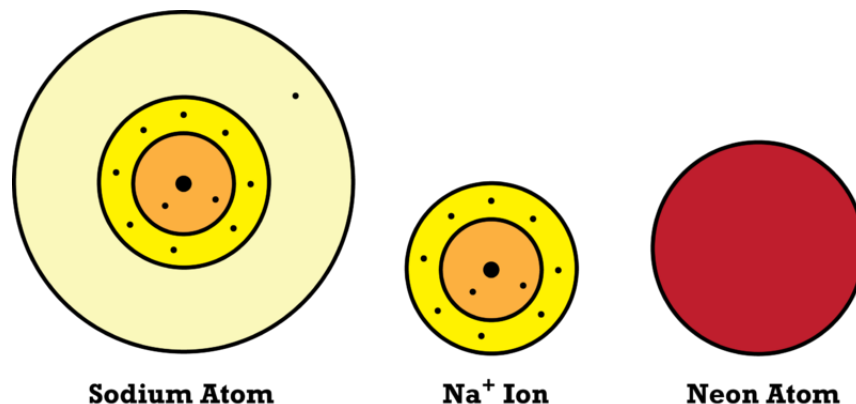

TABLE 10.1: The first four ionization energies of selected atoms

Atom	1st Ionization En- ergy (kJ/mole)	2nd Ionization En- ergy (kJ/mole)	3rd Ionization En- ergy (kJ/mole)	4th Ionization En- ergy (kJ/mole)
Na	496	4562	6912	9643
Mg	738	1450	7732	10,540
Al	578	1816	2745	11,577

In the chapter “Chemical Periodicity,” we learned that $IE_1 < IE_2 < IE_3 < IE_4$. If we examine the size that the ionization energy increases, however, and use that information along with the electron configurations and the type of ion formed, we can gain new insight. For each atom, there is one increase in ionization energies where the next ionization energy is at least four times the previous one. In the case of sodium, this very large jump in ionization energy occurs between the first and second ionization energy. For magnesium, the huge jump occurs between the second and third ionization energies, and for aluminum, it is between the third and fourth ionization energies. If we combine this information with the fact that sodium only forms a +1 ion, magnesium only forms a +2 ion, and aluminum only forms a +3 ion, we have a consistency in our observations that allows us to suggest an explanation.



The diagram above shows the electron distributions for a sodium atom and a Na^+ ion. For the sodium atom, the first two energy levels are full, and the third energy level contains only a single electron. When we remove the first electron from a sodium atom, we are removing the electron in the third energy level because it is the furthest

from the nucleus and thus has the lowest ionization energy. When that electron is removed, the third energy level is no longer available for electron removal. The sodium ion that remains has the same electron configuration as a neon atom. Although this Na^+ ion and a neon atom will have the same electron configuration, the Na^+ ion has a greater ionization energy than neon does because the sodium ion has one more proton in the nucleus. The sodium ion will also be slightly smaller than a neon atom (as indicated by the image above). When you have removed all the electrons in the outer energy level of an atom, the value of the next ionization energy will increase greatly because the next electron must be removed from a lower energy level.

Let's consider the same picture for magnesium.

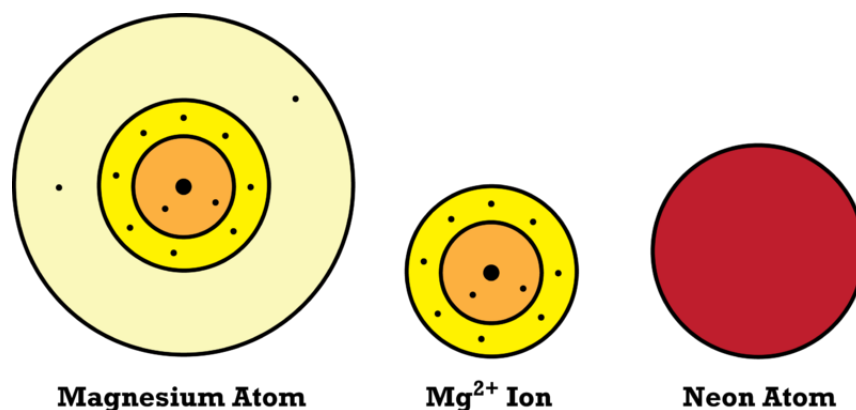

The magnesium atom has two electrons in the outermost energy level. When those two are removed, the resulting Mg^{2+} ion has the same electron configuration as neon does, but it is smaller than neon because the magnesium ion has two more protons in the nucleus. The first two ionization energies for magnesium are relatively small, but the third ionization is five times as large as the second. As a result, a magnesium atom can lose the first two electrons relatively easily, but it does not lose a third.

The huge jump in ionization energies is so consistent that we can identify the family of an unknown atom just by considering its ionization energies. If we had an unknown atom whose ionization energies were $\text{IE}_1 = 500 \text{ kJ/mol}$, $\text{IE}_2 = 1000 \text{ kJ/mol}$, $\text{IE}_3 = 2000 \text{ kJ/mol}$, and $\text{IE}_4 = 12,000 \text{ kJ/mole}$, we would immediately identify this atom as a member of family 3A. The large jump occurs between the 3rd and 4th ionization energies, so we know that only the first three electrons can be easily removed from this atom.

The logic for the formation of anions is very similar to that for cations. A fluorine atom, for example, has a high electron affinity and an available space for one electron in its outer energy level. When a fluorine atom takes on an electron, the potential energy of the fluorine ion is less than the potential energy of a fluorine atom. The fluoride ion that is formed has the same electron configuration as neon does, but it will be slightly larger than a neon atom because it has one less proton in the nucleus. As a result, the energy levels will not be pulled in as tightly. The electron affinity of a fluoride ion is essentially zero; the potential energy does not lower if another electron is added, so fluorine will take on only one extra electron.

An oxygen atom has a high electron affinity and has two spaces available for electrons in its outermost energy level. When oxygen takes on one electron, the potential energy of the system is lowered and energy is given off, but this oxygen ion has not filled its outer energy level; therefore, another electron can penetrate that electron shell. The oxygen ion (O^-) can accept another electron to produce the O^{2-} ion. This ion has the same electron configuration as neon does, and it will require an input of energy to force this ion to accept another electron.

Some Common Ions

All the metals in family 1A (shown in the figure below) have electron configurations ending with a single s electron in the outer energy level. For that reason, all members of the 1A family will tend to lose only one electron when ionized. The entire family forms $+1$ ions: Li^+ , Na^+ , K^+ , Rb^+ , Cs^+ , and Fr^+ . Note that although hydrogen (H) is in this same column, it is not considered to be a metal. There are times when hydrogen acts like a metal and forms $+1$ ions, but most of the time it bonds with other atoms as a nonmetal. In other words, hydrogen doesn't easily fit into any chemical family.

1A

The metals in family 2A (shown in the figure below) all have electron configurations ending with two s electrons in the outermost energy level. This entire family will form $+2$ ions: Be^{2+} , Mg^{2+} , Ca^{2+} , Sr^{2+} , Ba^{2+} , and Ra^{2+} .

All members of family 2A form ions with $2+$ charge.

2A

Family 3A members (shown in the figure below) have electron configurations ending in s^2p^1 . When these atoms form ions, they will almost always form $3+$ ions: Al^{3+} , Ga^{3+} , In^{3+} , and Tl^{3+} . Notice that boron is omitted from this list. This is because boron falls on the nonmetal side of the metal/nonmetal dividing line. Boron generally doesn't lose all of its valence electrons during chemical reactions.

3A

Family 4A is almost evenly divided into metals and nonmetals. The larger atoms in the family (germanium, tin, and lead) are metals. Since these atoms have electron configurations that end in s^2p^2 , they are expected to form ions with charges of +4. All three of the atoms do form such ions (Ge^{4+} , Sn^{4+} , and Pb^{4+}), but tin and lead also have the ability to also form +2 ions. You will learn later in this chapter that some atoms have the ability to form ions of different charges, and the reasons for this will be examined later.

Like family 4A, the elements of family 5A are also divided into metals and nonmetals. The smaller atoms in this family behave as nonmetals, and the larger atoms behave as metals. Since bismuth and arsenic both have electron configurations that end with s^2p^3 , they form +5 ions.

Most of the elements in family 6A (shown in figure below) are nonmetals that have electron configurations ending with s^2p^4 . These atoms generally have enough electron affinity to attract two more electrons to fill their outermost energy level. They form -2 ions: O^{-2} , S^{-2} , Se^{-2} , and Te^{-2} .

Family 7A are all nonmetals with high electron affinities and electron configurations that end with s^2p^5 . When these atoms form ions, they form -1 ions: F^{-} , Cl^{-} , Br^{-} , and I^{-} . Family 8A, of course, is made up of the noble gases, which have no tendency to either gain or lose electrons.

Polyatomic Ions

Thus far, we have been dealing with ions made from single atoms. Such ions are called monatomic ions. There are also **polyatomic ions**, which are composed of a group of covalently bonded atoms that behave as if they were a single ion. Almost all the common polyatomic ions are negative ions. The only common positive polyatomic ion is ammonium, NH_4^+ . The name and formula of ammonium ion is similar to ammonia (NH_3), but it is *not* ammonia, and you should not confuse the two. The following is a list of common polyatomic ions that you should be familiar with.

- Ammonium ion, NH_4^+
- Acetate ion, $\text{C}_2\text{H}_3\text{O}_2^-$
- Carbonate ion, CO_3^{2-}
- Chromate ion, CrO_4^{2-}
- Dichromate ion, $\text{Cr}_2\text{O}_7^{2-}$
- Hydroxide ion, OH^-
- Nitrate ion, NO_3^-
- Phosphate ion, PO_4^{3-}
- Sulfate ion, SO_4^{2-}
- Sulfite ion, SO_3^{2-}

You should know these well enough so that when someone says the name of a polyatomic ion, you can respond with the formula and charge, and if someone shows you the formula and charge, you can respond with the name.

Lesson Summary

- Ions are atoms or groups of atoms that carry electrical charge.
- A negative ion is called an anion, and a positive ion is called a cation.
- Atoms with low ionization energy and low electron affinity (metals) tend to lose electrons and become positive ions.
- Atoms with high ionization energy and high electron affinity (nonmetals) tend to gain electrons and become negative ions.
- Atoms with high ionization energy and low electron affinity (noble gases) tend to neither gain nor lose electrons.
- Atoms that tend to lose electrons will generally lose all the electrons in their outermost energy level.
- Atoms that tend to gain electrons will gain enough electrons to completely fill the *s* and *p* orbitals in their outermost energy level.
- Polyatomic ions are ions composed of a group of atoms that are covalently bonded and behave as if they were a single ion.

Review Questions

1. Define an ion.
2. In general, how does the ionization energy of metal compare to the ionization energy of a nonmetal?
3. Will an iron atom form a positive or negative ion? Why?
4. Will a bromine atom form a positive or negative ion? Why?
5. Which is larger, a fluorine atom or a fluoride ion?
6. How is the number of valence electrons of a metal atom related to the charge on the ion the metal will form?
7. How is the number of valence electrons of a nonmetal related to the charge on the ion the nonmetal will form?
8. If carbon were to behave like a metal and give up electrons, how many electrons would it give up?
9. How many electrons are in a typical sodium ion?
10. Explain why chlorine is a small atom that tends to take on an extra electron, but argon is an even smaller atom that does not tend to take on electrons.
11. If an atom had the following successive ionization energies, to which family would it belong? Why did you choose this family?

1st ionization energy = 75 kJ/mol

2nd ionization energy = 125 kJ/mol

3rd ionization energy = 1225 kJ/mol

4th ionization energy = 1750 kJ/mol

10.2 Ionic Compounds

Lesson Objectives

The student will:

- describe how atoms form an ionic bond.
- state, in terms of energy, why atoms form ionic bonds.
- state the octet rule.
- give a brief description of a lattice structure.
- identify distinctive properties of ionic compounds.

Vocabulary

- electrostatic attraction
- ionic bond
- lattice structure
- octet rule

Introduction

Collisions between atoms that tend to lose electrons (metals) and atoms that tend to gain electrons (nonmetals) are usually sufficient enough to remove the electrons from the metal atom and add them to the nonmetal atom. This transfer of electrons forms positive and negative ions, which in turn attract each other due to opposite charges. The compounds formed by this electrostatic attraction are said to be ionically bonded.

Ionic Bonding

When an atom with a low ionization energy encounters an atom with high electron affinity, it is possible for an electron transfer to occur. The ionization of the metal atom requires an input of energy. This energy input is often accomplished simply by the collision of atoms due to particle motion. Once electrons have been removed from the metal atoms, the electrons are taken on by the nonmetal atoms and energy is released. The energy released provides sufficient energy for the reaction to continue. In some cases, a reaction of this sort must be heated in order to start the reaction, but once the reaction begins, the reaction itself provides enough energy to continue.

The process of transferring an electron from a sodium atom to a chlorine atom, as shown in the sketch below, produces oppositely charged ions, which then stick together because of **electrostatic attraction**. Electrostatic attraction is the attraction between opposite charges. The electrostatic attraction between oppositely charged ions is called an **ionic bond**. Notice in the sketch above that the sodium atom is larger than the chlorine atom before the

collision, but after the electron transfer, the sodium ion is now smaller than the chloride ion. Recall that the sodium ion is smaller than a neon atom because it has one more proton in the nucleus than neon does, yet they both have the same electron configuration. The chloride ion is larger than an argon atom because while it has the same electron configuration as argon, it has one less proton in the nucleus than argon. The sodium ion now has high ionization energy and low electron affinity (just like a noble gas) so there is no reason for any further changes. The same is true for the chloride ion. These ions are chemically more stable than the atoms are.

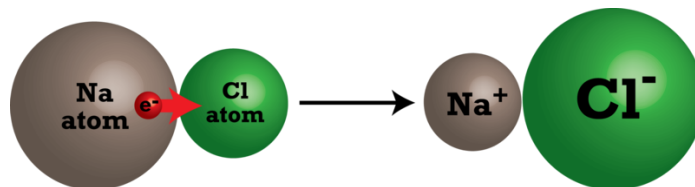

If we had been examining sodium and sulfur atoms, the transfer process would be only slightly different. Sodium atoms have a single electron in their outermost energy level and therefore can lose only one electron. Sulfur atoms, however, require two electrons to complete their outer energy level. In such a case, two sodium atoms would be required to collide with one sulfur atom, as illustrated in the diagram below. Each sodium atom would contribute one electron for a total of two electrons, and the sulfur atom would take on both electrons. The two Na atoms would become Na^+ ions, and the sulfur atom would become a S^{2-} ion. Electrostatic attractions would cause all three ions to stick together.

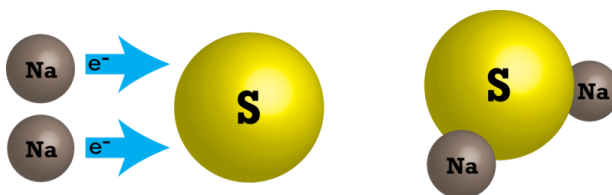

All the valence electrons for the main group elements are in s and p orbitals. When forming ions, main group metals will lose all of their valence electrons so that the resulting electron configuration will be the same as the previous noble gas. Usually, this means that the ion will have eight valence electrons. (Metals in the second row will form ions that have helium's electron configuration, which contains only two electrons.) Conversely, when nonmetals gain electrons to form anions, the new electron configuration will be the same as the following noble gas. The **octet rule** is an expression of the fact that when main group elements form ions, they tend to achieve a set of 8 valence electrons, which we know is a particularly stable configuration.

Properties of Ionic Compounds

When ionic compounds are formed, we are almost never dealing with just a single positive ion or a single negative ion. When ionic compounds are formed in laboratory conditions, many cations and anions are formed at the same time. The positive and negative ions are not just attracted to a single oppositely charged ion. The ions are attracted to several of the oppositely charged ions. The ions arrange themselves into organized patterns where each ion is surrounded by several ions of the opposite charge.

The organized patterns of positive and negative ions are called **lattice structures**. There are a number of different ionic lattice structures. The lattice structure that forms for a particular ionic compound is determined by the relative sizes of the ions and by the charge on the ions. Because ionic compounds form these large lattice structures in the solid phase, they are not referred to as molecules, but rather as lattice structures or crystals.

The image below shows the solid structure of sodium chloride. Only one layer is shown. When layers are placed above and below this one, each sodium ion would be touching six chloride ions – the four surrounding ones, one above, and one below. Each chloride ion will be touching six sodium ions in the same way.

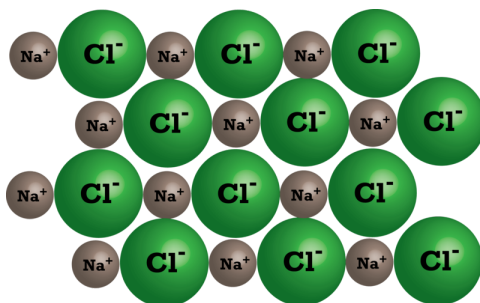

When electrons are transferred from metallic atoms to nonmetallic atoms during the formation of an ionic bond, the electron transfer is permanent. The electrons now belong to the nonmetallic ion. If the ionic lattice structure is taken apart by melting it to a liquid, vaporizing it to a gas, or dissolving it in water, the particles come apart in the form of ions. The electrons that were transferred go with the negative ion when the ions separate. The electrostatic attraction between the oppositely charged ions is quite strong, and therefore ionic compounds have very high melting and boiling points. Sodium chloride (table salt), for example, must be heated to around 800°C to melt and around 1500°C to boil.

If you look again at the image, you can see that negative ions are surrounded by positive ions and vice versa. If part of the lattice is shifted downward, negative ions will then be next to negative ions. Since like charges repel, the structure will break up. As a result, ionic compounds tend to be brittle solids. If you attempt to hammer down on ionic substances, they will shatter. This is very different from metals, which can be hammered into different shapes without the metal atoms separating from each other.

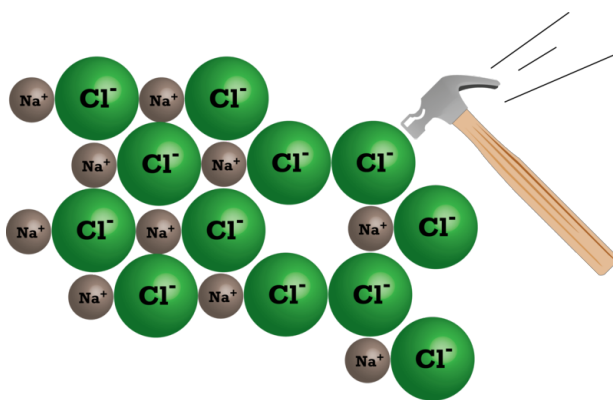

Ionic substances generally dissolve readily in water. When an ionic compound has been melted or dissolved in water, there are ions present that have the ability to move around in the liquid. It is specifically the presence of the mobile ions that allow electric current to be conducted by ionic liquids and ionic solutions. In comparison, non-ionic compounds that are dissolved in water or are in liquid form do not conduct electric current.

The process of gaining or losing electrons completely changes the chemical properties of the substances. The chemical and physical properties of an ionic compound will bear no resemblance to the properties of the elements which formed the ions. For example, sodium is a metal that is shiny, an excellent conductor of electric current, and reacts violently with water. Chlorine is a poisonous gas. When sodium and chlorine are chemically combined to form sodium chloride (table salt), the product has an entirely new set of properties. We could sprinkle sodium chloride on our food, which is not something we would do if we expected it to poison us or to explode when it touches water.

Lesson Summary

- Ionic bonds are the resulting electrostatic attraction holding ions together when electrons transfer from metal atoms to nonmetal atoms.
- The octet rule is an expression of the tendency for atoms to gain or lose the appropriate number of electrons so that the resulting ion has either completely filled or completely empty outer energy levels.
- Ionic compounds form ionic crystal lattices rather than molecules.
- Ionic compounds have very high melting and boiling points.
- Ionic compounds tend to be brittle solids.
- Ionic compounds are generally soluble in water, and the resulting solutions will conduct electricity.
- Ionic compounds have chemical properties that are unrelated to the chemical properties of the elements from which they were formed.

Further Reading / Supplemental Links

This website provides more information about ionic compounds.

- <http://misterguch.brinkster.net/ionic.html>

This video is a ChemStudy film called “Electric Interactions in Chemistry.” The film is somewhat dated but the information is accurate.

- <http://www.youtube.com/watch?v=o9TaQLVCFDM>

Review Questions

1. What takes place during the formation of an ionic bond?
2. What effect does the transfer of electrons have on the nuclei of the atoms involved?
3. Hydrogen gas and chlorine gas are not acids, but when hydrogen and chlorine combine to form hydrogen chloride, the compound is an acid. How would you explain this?
4. Why do we not refer to molecules of sodium chloride?

10.3 Writing Ionic Formulas

Lesson Objectives

The student will:

- provide the correct formulas for binary ionic compounds.
- provide the correct formulas for compounds containing metals with variable oxidation numbers.
- provide the correct formulas for compounds containing polyatomic ions.

Vocabulary

- empirical formula
- formula unit

Introduction

Ionic compounds do not exist as molecules. In the solid state, ionic compounds are in crystal lattices containing many cations and anions. An ionic formula, like NaCl, is an empirical formula. The **empirical formula** gives the simplest whole number ratio of atoms of each element present in the compound. The formula for sodium chloride merely indicates that it is made of an equal number of sodium and chloride ions. As a result, it is technically incorrect to refer to a molecule of sodium chloride. Instead, one unit of NaCl is called the **formula unit**. A formula unit is one unit of an empirical formula for an ionic compound.

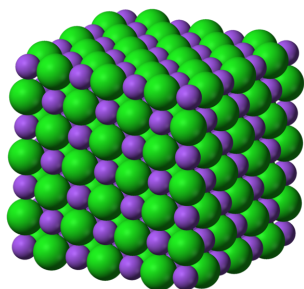

FIGURE 10.1

The three-dimensional crystal lattice structure of sodium chloride.

Sodium sulfide, another ionic compound, has the formula Na_2S . This formula indicates that this compound is made up of twice as many sodium ions as sulfide ions. Na_2S will also form a crystal lattice, but the lattice won't be the same as the NaCl lattice because the Na_2S lattice has to have two sodium ions per sulfide ion.

Predicting Formulas for Ionic Compounds

Determining Ionic Charge

The charge that will be on an ion can be predicted for most of the monatomic ions. Many of these ionic charges can be predicted for entire families of elements. There are a few ions whose charge must simply be memorized, and there are also a few that have the ability to form two or more ions with different charges. In these cases, the exact charge on the ion can only be determined by analyzing the ionic formula of the compound.

All of the elements in family 1A are metals that have the same outer energy level electron configuration, the same number of valence electrons (one), and low first ionization energies. Therefore, these atoms will lose their one valence electron and form ions with a +1 charge. This allows us to predict the ionic charges on all the 1A ions: Li^+ , Na^+ , K^+ , Rb^+ , Cs^+ , and Fr^+ .

Hydrogen is a special case. It has the ability to form a positive ion by losing its single valence electron, just as the 1A metals do. In those cases, hydrogen forms the +1 ion, H^+ . In rare cases, hydrogen can also take on one electron to complete its outer energy level. These compounds, such as NaH , KH , and LiH , are called hydrides. Hydrogen also has the ability to form compounds without losing or gaining electrons, which will be discussed in more details in the chapter “Covalent Bonds and Formulas.”

All of the elements in family 2A have the same outer energy level electron configuration and the same number of valence electrons (two). Each of these atoms is a metal with low first and second ionization energies. Therefore, these elements will lose both of its valence electrons to form an ion with a +2 charge. The ions formed in family 2A are: Be^{2+} , Mg^{2+} , Ca^{2+} , Sr^{2+} , Ba^{2+} , and Ra^{2+} .

There is a slight variation for the elements in family 3A. The line separating metals from nonmetals on the periodic table cuts through family 3A between boron and aluminum. In family 3A, boron, $1s^2 2s^2 2p^1$, behaves as a nonmetal due to its higher ionization energy and higher electron affinity. Aluminum, on the other hand, is on the metallic side of the line and behaves as an electron donor. Aluminum, $1s^2 2s^2 2p^6 3s^2 3p^1$, always loses all three of its valence electrons and forms an Al^{3+} ion. Gallium and indium have the same outer energy level configuration as aluminum, and they also lose all three of their valence electrons to form the +3 ions Ga^{3+} and In^{3+} . Thallium, whose electron configuration ends with $6s^2 6p^1$, could also form a +3 ion, but for reasons beyond the scope of this book, thallium is more stable as the +1 ion Tl^+ .

All the elements in the 6A family have six valence electrons, and they all have high electron affinities. These atoms will, therefore, take on additional electrons to complete the octet of electrons in their outer energy levels. Since each atom will take on two electrons to complete its octet, members of the 6A family will form -2 ions. The ions formed will be: O^{2-} , S^{2-} , Se^{2-} , and Te^{2-} .

Family 7A elements have the outer energy level electron configuration $ns^2 np^5$. These atoms have the highest electron affinities in their periods and will each take on one more electron to complete the octet of electrons in the outer energy levels. Therefore, these atoms will form -1 ions: F^- , Cl^- , Br^- , I^- , and At^- .

Family 8A elements have completely filled outer energy levels. Because of this, it is very energetically unfavorable to either add or remove electrons, and elements found in family 8A do not form ions.

Transition Elements

There are greater variations in the charge found on ions formed from transition elements. Many of the transition elements can form ions with different charges. We will consider some of these elements later in this chapter. There are also some transition elements that only form one ion.

Consider the electron configuration of silver, Ag, is $1s^2 2s^2 2p^6 3s^2 3p^6 4s^2 3d^{10} 4p^6 5s^1 4d^{10}$. When forming an ion, silver loses its single valence electron to produce Ag^+ . Note that its electron configuration does not exactly follow

the rules that you have been shown for filling orbitals. Electrons have been placed in 4 *d* orbitals even though the 5*s* orbital, which is usually lower in energy, is not completely full. Because the 4*d* and 5*s* orbitals are so similar in energy, very small perturbations can sometimes make it energetically favorable for the 5*s* electron to move into a 4*d* orbital. It happens that a set of half full (5 electrons) or completely full (10 electrons) *d* orbitals gives a little extra stability to the electron configuration. This also happens with chromium, copper, molybdenum, and gold.

The electron configuration for Zn is $[\text{Ar}]4s^23d^{10}$. Like main group metals, zinc loses all of its valence electrons when it forms an ion, so it forms a Zn^{2+} ion. Cadmium is similar. The electron configuration for Cd is $[\text{Kr}]5s^23d^{10}$, so it forms a Cd^{2+} ion.

Writing Basic Ionic Formulas

In writing formulas for binary ionic compounds (binary refers to two elements, *not* two single atoms), the cation is always written first. Chemists use subscripts following the symbol of each element to indicate the number of that element present in the formula. For example, the formula Na_2O indicates that the compound contains two atoms of sodium for every one oxygen. When the subscript for an element is 1, the subscript is omitted. The number of atoms of an element with no indicated subscript is always read as 1. When an ionic compound forms, the number of electrons given off by the cations must be exactly the same as the number of electrons taken on by the anions. Therefore, if calcium, which gives off two electrons, is to be combined with fluorine, which takes on one electron, then one calcium atom must combine with two fluorine atoms. The formula would be CaF_2 .

Suppose we wish to write the formula for the compound that forms between aluminum and chlorine. To write the formula, we must first determine the oxidation numbers of the ions that would be formed. We will revisit the concept of oxidation numbers later, but for now, all you need to know is that the oxidation number for an atom in an ionic compound is equal to the charge of the ion it produces.



Then, we determine the simplest whole numbers with which to multiply these charges so they will balance (add to zero). In this case, we would multiply the 3+ by 1 and the 1- by 3.



You should note that we could multiply the 3+ by 2 and the 1- by 6 to get 6+ and 6-, respectively. These values will also balance, but this is *not* acceptable because empirical formulas, by definition, must have the lowest whole number multipliers. Once we have the *lowest* whole number multipliers, those multipliers become the subscripts for the symbols. The formula for this compound would be AlCl_3 .

Here's the process for writing the formula for the compound formed between aluminum and sulfur.



Therefore, the formula for this compound would be Al_2S_3 .

Another method used to write formulas is called the criss-cross method. It is a quick method, but it often produces errors if the user doesn't pay attention to the results. The example below demonstrates the criss-cross method for writing the formula of a compound formed from aluminum and oxygen. In the criss-cross method, the oxidation numbers are placed over the symbols for the elements just as before.



In this method, the oxidation numbers are then criss-crossed and used as the subscripts for the other atom (ignoring sign).



This produces the correct formula Al_2O_3 for the compound. Here's an example of a criss-cross error:

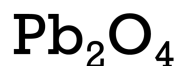
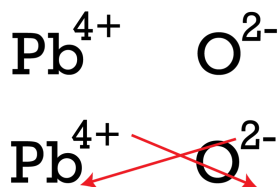

If you used the original method of finding the lowest multipliers to balance the charges, you would get the correct formula PbO_2 , but the criss-cross method produces the incorrect formula Pb_2O_4 . If you use the criss-cross method to generate an ionic formula, it is essential that you check to make sure that the subscripts correspond to the lowest whole number ratio of the atoms involved. Note that this only applies to ionic compounds. When we learn about covalent compounds in the chapter "Covalent Bonds and Formulas," you will see that the formula N_2O_4 describes a different molecule than NO_2 , so it would not be reduced to its simplest ratio.

Metals with Variable Oxidation Number

When writing formulas, you are given the oxidation number. When we get to naming ionic compounds, however, it is absolutely vital that you are able to recognize metals that can have more than one oxidation number. A partial list of metals with variable oxidation numbers includes iron, copper, tin, lead, nickel, and gold.

For example, iron can form both Fe^{2+} and Fe^{3+} ions. The electron configuration for neutral Fe is $1s^2 2s^2 2p^6 3s^2 3p^6 4s^2 3d^6$. It is fairly straightforward as to why iron forms the 2+ ion, because it loses all of its valence electrons like other metals do. The electron configuration for the Fe^{2+} ion is $[\text{Ar}]3d^6$. Why would the iron ion lose one more electron? Earlier, we mentioned that the d orbitals have a slightly lower energy when they are exactly half full or completely full. If this Fe^{2+} ion were to lose one more electron, the $3d$ orbitals would be exactly half full with five electrons. When iron reacts, it will first form Fe^{2+} . However, if the pull on its electrons is particularly strong, it will form Fe^{3+} .

Other examples of metals with variable oxidation states are less intuitive. For example, copper, silver, and gold (a single family of metals) can all lose a single electron to form Cu^+ , Ag^+ , and Au^+ . All subshells in the resulting ions are completely full or empty. However, copper can also form Cu^{2+} , which is actually more stable in many cases. Gold can form Au^{3+} , but Au^{2+} is rarely observed. Silver, as we mentioned earlier, does not commonly lose more than one electron.

The oxidation states available to main group metals are generally easy to predict. However, tin and lead are two exceptions. In addition to losing all four of their valence electrons to make Sn^{4+} and Pb^{4+} , tin and lead will also commonly form Sn^{2+} and Pb^{2+} ions. There are many metals with variable oxidation states, but it is worth memorizing at least the ones mentioned here (Fe, Cu, Au, Sn, Pb).

Polyatomic Ions

Polyatomic ions require additional consideration when you write formulas involving them. Recall from earlier this list of common polyatomic ions:

- Ammonium ion, NH_4^+
- Acetate ion, $\text{C}_2\text{H}_3\text{O}_2^-$
- Carbonate ion, CO_3^{2-}
- Chromate ion, CrO_4^{2-}
- Dichromate ion, $\text{Cr}_2\text{O}_7^{2-}$
- Hydroxide ion, OH^-
- Nitrate ion, NO_3^-
- Phosphate ion, PO_4^{3-}
- Sulfate ion, SO_4^{2-}
- Sulfite ion, SO_3^{2-}

Suppose we are asked to write the formula for the compound that would form between calcium and the nitrate ion. We begin by putting the charges above the symbols just as before.



The multipliers needed to balance these ions are 1 for calcium and 2 for nitrate. We wish to write a formula that tells our readers that there are two nitrate ions in the formula for every calcium ion. When we put the subscript 2 beside the nitrate ion in the same fashion as before, we get something strange – CaNO_32 . With this formula, we are indicating 32 oxygen atoms, which is wrong. The solution to this problem is to put parentheses around the nitrate ion before the subscript is added. Therefore, the correct formula is $\text{Ca}(\text{NO}_3)_2$. Similarly, calcium phosphate would be $\text{Ca}_3(\text{PO}_4)_2$. If a polyatomic ion does not need a subscript other than an omitted 1, then the parentheses are not needed. Although including these unnecessary parentheses does not change the meaning of the formula, it may cause the reader to wonder whether a subscript was left off by mistake. Try to avoid using parentheses when they are not needed.

Example:

Write the formula for the compound that will form from aluminum and acetate.



The charge on an aluminum ion is +3, and the charge on an acetate ion is -1. Therefore, three acetate ions are required to combine with one aluminum ion. This is also apparent by the criss-cross method. However, we cannot place a subscript of 3 beside the oxygen subscript of 2 without inserting parentheses first. Therefore, the formula will be $\text{Al}(\text{C}_2\text{H}_3\text{O}_2)_3$.

Example:

Write the formula for the compound that will form from ammonium and phosphate.



The charge on an ammonium ion is +1 and the charge on a phosphate ion is -3. Therefore, three ammonium ions are required to combine with one phosphate ion. The criss-cross procedure will place a subscript of 3 next to the subscript 4. This can only be carried out if the ammonium ion is first placed in parentheses. Therefore, the proper formula is $(\text{NH}_4)_3\text{PO}_4$.

Example:

Write the formula for the compound that will form from aluminum and phosphate.



Since the charge on an aluminum ion is +3 and the charge on a phosphate ion is -3, these ions will combine in a one-to-one ratio. In this case, the criss-cross method would produce an incorrect answer. Since it is not necessary to write the subscripts of 1, no parentheses are needed in this formula. Since parentheses are not needed, it is generally considered incorrect to use them. The correct formula is AlPO_4 .

More Examples:

Magnesium hydroxide $\text{Mg}(\text{OH})_2$

Sodium carbonate Na_2CO_3

Barium acetate $\text{Ba}(\text{C}_2\text{H}_3\text{O}_2)_2$

Ammonium dichromate $(\text{NH}_4)_2\text{Cr}_2\text{O}_7$

Lesson Summary

- The oxidation number for ions of the main group elements can usually be determined by the number of valence electrons.
- Some transition elements have fixed oxidation numbers, while others have variable oxidation numbers.
- Some metals, such as iron, copper, tin, lead, and gold, also have variable oxidation numbers.
- Formulas for ionic compounds contain the lowest whole number ratio of subscripts such that the sum of all positive charges equals the sum of all negative charges.

Further Reading / Supplemental Links

This website provides more details about ionic bonding, including a conceptual simulation of the reaction between sodium and chlorine. The website also discusses covalent bonding, the focus of the chapter “Covalent Bonds and Formulas.”

- http://visionlearning/library/module_viewer.php?mid=55

Review Questions

1. Fill in the chart below (**Table 10.2**) by writing formulas for the compounds that might form between the ions in the columns and rows. Some of these compounds don't exist but you can still write formulas for them.

TABLE 10.2:

	Na^+	Ca^{2+}	Fe^{3+}	NH_4^+	Sn^{4+}
NO_3^-					
SO_4^{2-}					
Cl^-					
S^{2-}					
PO_4^{3-}					
OH^-					
$\text{Cr}_2\text{O}_7^{2-}$					
CO_3^{2-}					

10.4 Naming Ionic Compounds

Lesson Objectives

The student will:

- correctly name binary ionic compounds, compounds containing metals with variable oxidation numbers, and compounds containing polyatomic ions when given the formulas.
- provide chemical formulas for binary ionic compounds, compounds containing metals with variable oxidation numbers, and compounds containing polyatomic ions when given the names.

Introduction

It is necessary for each symbol and each name in chemistry to be completely unique. Using an incorrect substance in a chemistry experiment could have disastrous results, so the names and symbols of elements and compounds must refer to exactly one substance. For beginning students, the system of naming chemicals can seem impossibly complex. This section presents the rules for naming various ionic compounds.

Rules for Naming Ionic Compounds

When an atom gains or loses electrons to form an ion, its name sometimes changes. Main group metals retain their name when forming cations. For example, K^+ is a potassium ion, and Mg^{2+} is a magnesium ion. However, when nonmetallic elements gain electrons to form anions, the ending of their names is changed to “-ide.” For example, a fluorine atom gains one electron to become a fluoride ion (F^-), and sulfur gains two electrons to become a sulfide ion (S^{2-}). Polyatomic ions have names that you simply need to memorize. A list of common polyatomic ions was presented earlier in the chapter.

Binary Ionic Compounds

Binary ionic compounds are compounds that contain only two kinds of ions, regardless of how many of each ion is present. To name such compounds, you simply write the name of the cation followed by the name of the anion. Unless you are dealing with a metal that can have multiple oxidation states, there is no need to indicate the relative number of cations and anions, since there is only one possible ratio that will give you a neutral compound.

Examples:

$MgCl_2$ magnesium chloride

$NaBr$ sodium bromide

AlF_3 aluminum fluoride

K_2S potassium sulfide

CaI_2 calcium iodide

Rb_2O rubidium oxide

H_3N hydrogen nitride

Polyatomic Ions

When naming a compound containing a polyatomic ion, the name of the polyatomic ion does not change regardless of whether it is written first or last in the formula. If the formula contains a positive polyatomic ion and a nonmetal, the ending of the nonmetal is replaced with “-ide.” If the compound contains a metal and a polyatomic ion, both the metal and the polyatomic ion are written without any changes to their names.

Examples:

$\text{NaC}_2\text{H}_3\text{O}_2$ sodium acetate

$\text{Mg}(\text{NO}_3)_2$ magnesium nitrate

$(\text{NH}_4)_2\text{CrO}_4$ ammonium chromate

$(\text{NH}_4)_2\text{S}$ ammonium sulfide

$\text{Ca}(\text{OH})_2$ calcium hydroxide

BaCr_2O_7 barium dichromate

H_3PO_4 hydrogen phosphate

Variable Oxidation Number Metals

Metals with variable oxidation numbers may form multiple different compounds with the same nonmetal. Iron, for example, may react with oxygen to form either FeO or Fe_2O_3 . These are very different compounds with different properties. When we name these compounds, it is absolutely vital that we clearly distinguish between them. They are both iron oxides, but in FeO , iron has an oxidation number of +2, while in Fe_2O_3 , it has an oxidation number of +3. The rule for naming these compounds is to write the oxidation number of the metal after the name. The oxidation number is written using Roman numerals and is placed in parentheses. For these two examples, the compounds would be named iron(II) oxide and iron(III) oxide. When you see that the compound involves a metal with multiple oxidation numbers, you must determine the oxidation number of the metal from the formula and indicate it using Roman numerals.

In general, main group metal ions have only one common oxidation state, whereas most of the transition metals have more than one. However, there are plenty of exceptions to this guideline. Main group metals that can have more than one oxidation state include tin (Sn^{2+} or Sn^{4+}) and lead (Pb^{2+} or Pb^{4+}). Transition metals with only one common oxidation state include silver (Ag^+), zinc (Zn^{2+}), and cadmium (Cd^{2+}). These should probably be memorized, but when in doubt, include the Roman numerals for transition metals. Do not do this for main group metals that do not have more than one oxidation state. Referring to AgCl as silver(I) chloride is redundant and may be considered wrong. However, copper chloride is definitely incorrect, because it could refer to either CuCl or CuCl_2 .

Other than the use of Roman numerals to indicate oxidation state, naming these ionic compounds is no different than what we have already seen. For example, consider the formula CuSO_4 . We know that the sulfate anion has a charge of -2. Therefore, for this to be a neutral compound, copper must have a charge of +2. The name of this compound is copper(II) sulfate.

How about SnS_2 ? Tin is a variable oxidation number metal. We need a Roman numeral in the name of this compound. The oxidation number of sulfur is -2. Two sulfide ions were necessary to combine with one tin ion. Therefore, the oxidation number of the tin must be +4, and the name of this compound is tin(IV) sulfide.

Examples:

PbO..... lead(II) oxide

FeI₂..... iron(II) iodide

Fe₂(SO₄)₃..... iron(III) sulfate

AuCl₃..... gold(III) chloride

CuO..... copper(II) oxide

PbS₂..... lead(IV) sulfide

The most common error made by students in naming these compounds is to choose the Roman numeral based on the number of atoms of the metal. The Roman numeral in these names is the oxidation number of the metal. For example, in PbS₂, the oxidation state of lead (Pb) is +4, so the Roman numeral following the name lead is IV. Notice that there is no four in the formula. As in previous examples, the empirical formula is always the lowest whole number ratio of the ions involved. Think carefully when you encounter variable oxidation number metals. Make note that the Roman numeral does not appear in the formula but does appear in the name.

Lesson Summary

- Cations have the same name as their parent atom.
- Monatomic anions are named by replacing the end of the parent atom's name with "-ide."
- The names of polyatomic ions do not change.
- Ionic compounds are named by writing the name of the cation followed by the name of the anion.
- When naming compounds that include a metal with more than one common oxidation state, the charge of the metal ion is indicated with Roman numerals in parentheses between the cation and anion.

Review Questions

1. Name the following compounds.
 - a. CaF₂
 - b. (NH₄)₂CrO₄
 - c. K₂CO₃
 - d. NaCl
 - e. PbO
 - f. CuSO₄
 - g. Ca(NO₃)₂
 - h. Mg(OH)₂
 - i. SnO₂
2. Write the formulas from the names of the following compounds.
 - a. Sodium carbonate
 - b. Calcium hydroxide
 - c. Iron(III) nitrate
 - d. Magnesium oxide
 - e. Aluminum sulfide
 - f. Copper(I) dichromate
 - g. Ammonium sulfate
 - h. Iron(II) phosphate
 - i. Lead(IV) sulfate

All images, unless otherwise stated, are created by the CK-12 Foundation and are under the Creative Commons license CC-BY-NC-SA.

10.5 References

1. Benjah-bmm27. [3D structure of sodium chloride](#). Public domain

CHAPTER 11**Covalent Bonds and Formulas****Chapter Outline**

- 11.1 THE COVALENT BOND**
 - 11.2 COVALENT FORMULAS AND NOMENCLATURE**
 - 11.3 ELECTRONIC AND MOLECULAR GEOMETRY**
 - 11.4 THE GEOMETRICAL ARRANGEMENT OF ELECTRONS AND MOLECULAR SHAPE**
-

11.1 The Covalent Bond

Lesson Objectives

The student will:

- explain what covalent bonds are.
- explain why covalent bonds are formed.
- compare covalent bonds with ionic bonds in terms of how their definitions and how they are formed.
- draw Lewis structures for simple covalent molecules.
- use Lewis structures to show the formation of single, double, and triple covalent bonds.
- identify pairs of atoms that will form covalent bonds.
- define coordinate covalent bond.
- explain the equivalent bond strengths in resonance structures.

Vocabulary

- bond energy
- bond length
- coordinate covalent bond
- covalent bond
- double bond
- pi bond
- resonance
- sigma bond
- triple bond

Introduction

As we saw in the chapter “Ionic Bonds and Formulas,” metallic atoms can transfer one or more electrons to nonmetallic atoms, producing positively charged cations and negatively charged anions. The attractive force between these oppositely charged ions is called an ionic bond. However, chemical bonding does not require the complete transfer of electrons from one atom to another. When a bond forms between two nonmetallic atoms, neither has a low enough electronegativity to completely give up an electron to its partner. Instead, the atoms overlap their orbitals, and the electrons residing in these shared orbitals can be considered to be in the valence shells of both atoms at the same time. These atoms are now in a **covalent bond**, held together by the attraction of both nuclei to the shared electrons.

Ionic versus Covalent Bonding

The way that atoms bind together is due to a combination of factors: the electrical attraction and repulsion between atoms, the arrangement of electrons in atoms, and the natural tendency for matter to achieve the lowest potential energy possible. In most cases, these factors favor atoms that have obtained a complete octet of valence electrons. In ionic bonding, the atoms acquired this octet by gaining or losing electrons, while in covalent bonding, the atoms acquire the noble gas electron configuration by sharing electrons.

As you may recall from the discussion of ionic bonds in the chapter “Ionic Bonds and Formulas,” ionic bonds form between metals and nonmetals. Nonmetals, which have high electronegativity, are able to take electrons away from metals. The oppositely charged metal and nonmetal ions will then be attracted to each other. In covalent bonds, electrons are shared, meaning that metals will form few, if any, covalent bonds. Metals do not hold on to electrons with enough strength to participate in covalent bonding. For a covalent bond to form, we need two atoms that both attract electrons strongly, or two atoms with high electronegativity. Hence, the great majority of covalent bonds will form between two nonmetals. When both atoms in a bond are from the right side of the periodic table, the bond is most likely to be covalent.

An animation showing ionic and covalent bonding (**2a**) is available at <http://www.youtube.com/watch?v=QqjCvzWwww> (1:57).

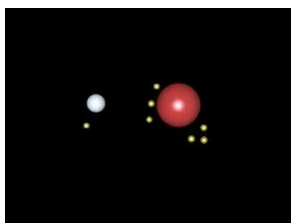

MEDIA

Click image to the left for more content.

Single Bond

In covalent bonding, the atoms acquire a stable octet of electrons by sharing electrons. The covalent bonding process produces molecular substances, as opposed to the lattice structures produced by ionic bonding. The covalent bond, in general, is much stronger than the ionic bond, and there are far more covalently bonded substances than ionically bonded ones.

The simplest covalent bond is made between two atoms of hydrogen. Each hydrogen atom has one electron in its $1s$ orbital. When two hydrogen atoms approach one another and their orbitals overlap, it creates a common volume between the two nuclei that both electrons occupy (as seen in the figure below). Since these electrons are shared, both hydrogen atoms now have a full valence shell.

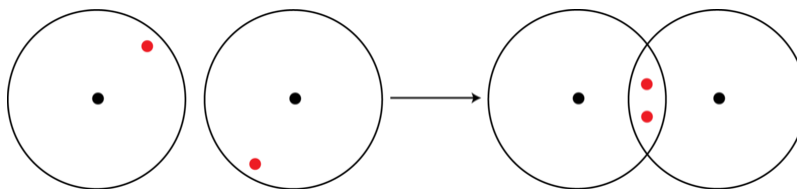

Since electrons are constantly in motion, they will not always be directly in the center of a covalent bond. However, the simulated probability pattern below shows that they do spend the majority of their time in the area directly between the two nuclei. The extra time spent between the two nuclei is the source of the attraction that holds the atoms together in a covalent bond.

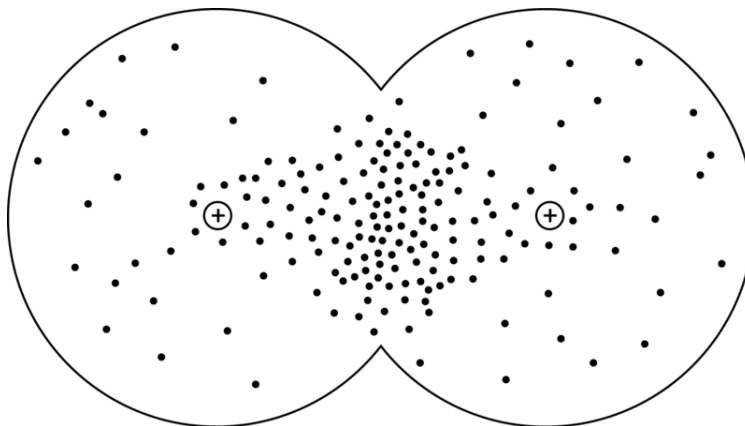

Another example of a covalent bond is found in the diatomic F_2 molecule (seen below). Recall that fluorine atoms have 7 valence electrons. Two are placed in the $2s$ orbital, and five are placed in the three $2p$ orbitals. Since each orbital can hold two electrons, this means that one of the $2p$ orbitals is only half full, so it is available for bonding. When two fluorine atoms interact, their half-filled orbitals overlap, creating a covalent bond that gives both atoms a complete octet of valence electrons.

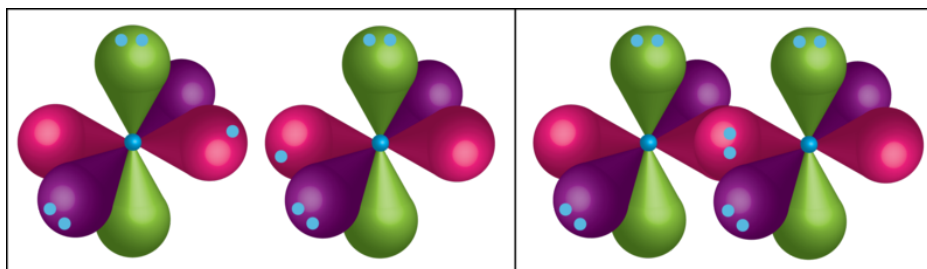

Some Compounds Have Both Covalent and Ionic Bonds

If you recall the introduction to polyatomic ions, you will remember that the bonds that hold the polyatomic ions together are covalent bonds. Once the polyatomic ion is constructed with covalent bonds, it reacts with other substances as an ion. The bond between a polyatomic ion and another ion will be ionic. An example of this type of situation is in the compound sodium nitrate. Sodium nitrate is composed of a sodium ion and a nitrate ion. The nitrate ion is held together by covalent bonds, and the nitrate ion is attached to the sodium ion by an ionic bond (see sketch below).

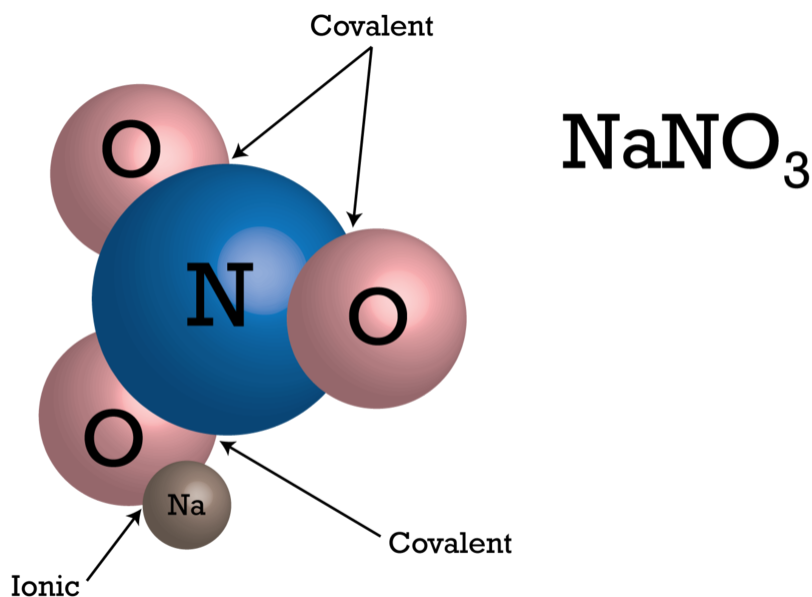

Bond Strength

When atoms that attract each other move closer together, the potential energy of the system (the two atoms) decreases. When a covalent bond is formed, the atoms move so close together that their electron clouds overlap. As the atoms continue to move closer yet, the potential energy of the system continues to decrease – to a point. If you continue to move atoms closer and closer together, eventually the two nuclei will begin to repel each other. If you push the nuclei closer together beyond this point, the repulsion causes the potential energy to increase. Each pair of covalently bonding atoms will have a distance between their nuclei that is the lowest potential energy distance. This position has the atoms close enough for the attraction between the nucleus of one atom and the electrons of the other is maximum, but not too close that the nuclei have not begun to repel each other strongly. This distance is called the bond length. The more potential energy released as this bond formed, the stronger the bond will be. In order to break this bond, you must input an equivalent amount of energy.

The strength of a diatomic covalent bond can be expressed by the amount of energy necessary to break the bond and produce separate atoms. The energy needed to break a covalent bond is called **bond energy** and is measured in kilojoules per mole. Bond energy is used as a measure of bond strength. The bond strength of HBr is 365 kilojoules per mole, meaning that it would take 365 kilojoules to break all the chemical bonds in 1 mole, or 6.02×10^{23} molecules, of HBr and produce separate hydrogen and bromine atoms. In comparison, the bond strength of HCl is 431 kilojoules per mole. Consequently, the bond in HCl is stronger than the bond in HBr.

Molecular Stability

The bond energy can be used to indicate molecular stability. When stable compounds are formed, large amounts of energy are given off. In order to break the molecule apart, all the energy that was given off must be put back in. The more energy needed to break a bond, the more stable the compound will be. Therefore, compounds with higher bond strengths tend to be more stable.

The molecule of glucose, shown below, can react with six molecules of oxygen to produce six molecules of carbon dioxide and six molecules of water. During the reaction, the atoms of the glucose molecule are rearranged into the structures of carbon dioxide and water. The bonds in glucose are broken, and new bonds are formed. As this occurs,

potential energy is released because the new bonds have lower potential energy than the original bonds. Since the bonds in the products are lower energy bonds, the product molecules are more stable than the reactants.

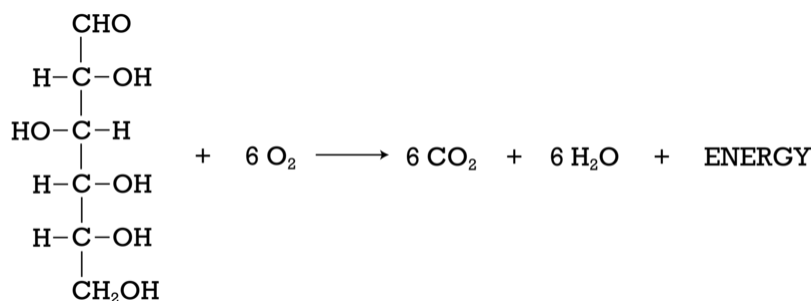

Double and Triple Bonds

In the previous examples, only one pair of electrons was shared between the two bonded atoms. This type of bond is called a single bond. However, it is possible for atoms to share more than one pair of electrons. When two or three pairs of electrons are shared by two bonded atoms, they are referred to as **double bonds** or **triple bonds**, respectively.

A double bond is formed when two pairs of orbitals overlap with each other at the same time. The O_2 molecule provides an example of a double bond. Oxygen has six valence electrons. Two electrons are placed in the $2s$ orbital, while the remaining four are distributed among the three $2p$ orbitals. Hund's rule tells us that each p orbital will receive one electron before a second electron is added, so the oxygen atom will have two half-filled orbitals available for bonding (a filled orbital will not participate in bonding).

Of the two p orbitals available for bonding, the first pair will have a head-to-head overlap, placing the shared electrons directly in between the two nuclei. This type of a bond, shown in the figure below, is called a **sigma (σ) bond**.

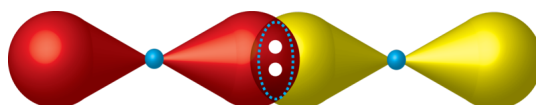

The second pair of half-filled orbitals is orientated perpendicularly to the first pair, so a similar head-to-head overlap is not possible. However, a bond can still be made by overlapping the two p orbitals side-by-side, as shown in the figure below. This type of bond is called a **pi (π) bond**.

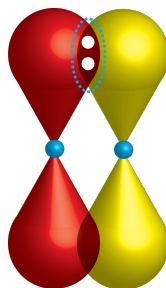

Whenever possible, the first bond will form directly between the two atomic nuclei involved in bonding. This allows for maximum overlap between the two orbitals, helping to minimize the electrostatic repulsion between the two positively charged nuclei. Thus, single bonds consist of one sigma bond, double bonds consist of one sigma and one pi bond, and triple bonds consist of one sigma and two pi bonds.

Note that double bonds are less than twice as strong as a single bond between the same two atoms. Since sigma bonds are “better” (stronger) than pi bonds, a combination of one sigma and one pi is slightly weaker than adding two sigma bonds together.

Lewis Dot Structures

It would not be very efficient if we had to draw an orbital picture every time we wanted to describe a molecule. Lewis dot structures, first developed by G.N. Lewis, are a shorthand way of drawing the arrangement of atoms, bonds, and valence electrons in a molecule. In the earlier chapter “The Electron Configuration of Atoms,” we introduced Lewis dot diagrams for drawing individual atoms. When we draw molecules, the diagrams are known as Lewis dot formulas, Lewis structures, or Lewis formulas. The Lewis structures of a molecule show how the valence electrons are arranged among the atoms of the molecule.

In a Lewis structure, each valence electron is represented by a dot, and bonds are shown by placing electrons in between the symbols for the two bonded atoms. Often, a pair of bonding electrons is further abbreviated by a dash. For example, we can represent the covalent bond in the F_2 molecule by either of the Lewis structures shown below.

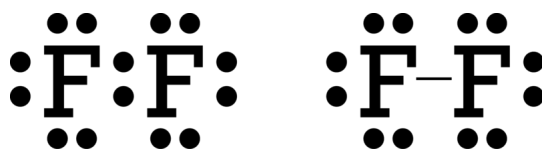

Double bonds (4 electrons shared between two atoms) can be represented either with 4 dots or 2 dashes. The Lewis structure for an oxygen molecule (O_2) is shown below.

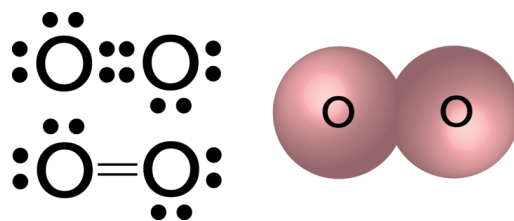

Similarly, triple bonds can be written as 6 dots or 3 dashes. An example of a molecule with triple bonds is the nitrogen molecule, N_2 . The Lewis structure for a nitrogen molecule can be represented by either of the two ways shown below. It is important to keep in mind that a dash always represents a pair of electrons. .

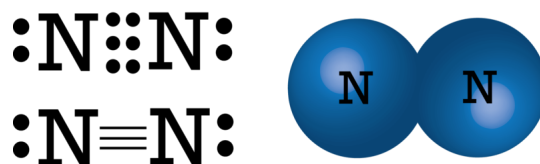

Several other examples of representing covalent bonds are shown in the figure below.

Phosphorus Trichloride

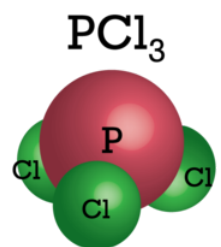

Water

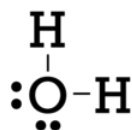
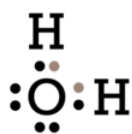
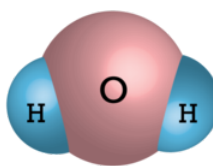
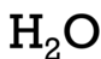

Carbon Dioxide

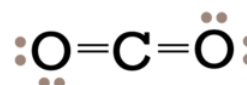
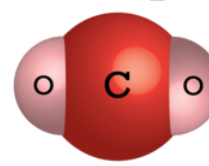

Drawing Lewis Structures

The rules outlined below for writing Lewis structures are based on observations of thousands of molecules (note that there will be some exceptions to the rules). We learned earlier that atoms are generally most stable with 8 valence electrons (the octet rule). The major exception is hydrogen, which requires only 2 valence electrons to have a complete valence shell (sometimes called the duet rule). Lewis structures allow one to quickly assess whether each atom has a complete octet (or duet) of electrons.

Rules for Writing Lewis Structures:

1. Decide which atoms are bounded.
2. Count all the valence electrons of all the atoms.
3. Place two electrons between each pair of bounded atoms.
4. Complete all the octets (or duets) of the atoms attached to the central atom.
5. Place any remaining electrons on the central atom.
6. If the central atom does not have an octet, look for places to form double or triple bonds.

Example:

Write the Lewis structure for water, H_2O .

Step 1: Decide which atoms are bounded.

Begin by assuming the hydrogen atoms are bounded to the oxygen atom. In other words, assume the oxygen atom is the central atom.

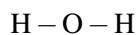

Step 2: Count all the valence electrons of all the atoms.

The oxygen atom has 6 valence electrons, and each hydrogen has 1. The total number of valence electrons is 8.

Step 3: Place two electrons between each pair of bounded atoms.



Step 4: Complete all the octets or duets of the atoms attached to the central atom.

The hydrogen atoms are attached to the central atom and require a duet of electrons. Those duets are already present.

Step 5: Place any remaining electrons on the central atom.

The total number of valence electrons is 8, and we have already used 4 of them. The other 4 will fit around the central oxygen atom.

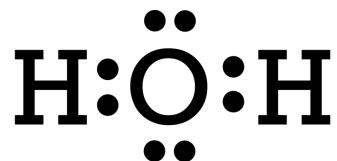

Is this structure correct?

- Are the total number of valence electrons correct? Yes
- Does each atom have the appropriate duet or octet of electrons? Yes

The structure, then, is correct.

Example:

Write the Lewis structure for carbon dioxide, CO_2 .

Step 1: Decide which atoms are bounded.

Begin by assuming the carbon is the central atom and that both oxygen atoms are attached to the carbon.

Step 2: Count all the valence electrons of all the atoms.

The oxygen atoms each have 6 valence electrons and the carbon atom has 4. The total number of valence electrons is 16.

Step 3: Place two electrons between each pair of bounded atoms.



Step 4: Complete all the octets or duets of the atoms attached to the central atom.

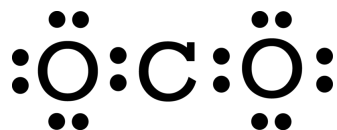

Step 5: Place any remaining electrons on the central atom.

We have used all 16 of the valence electrons so there are no more to place around the central carbon atom.

Is this structure correct?

- Is the total number of valence electrons correct? Yes
- Does each atom have the appropriate duet or octet of electrons? NO

Each oxygen has the proper octet of electrons, but the carbon atom only has 4 electrons. Therefore, this structure is *not* correct.

Step 6: If the central atom does not have an octet, look for places to form double or triple bonds.

Double bonds can be formed between carbon and each oxygen atom.

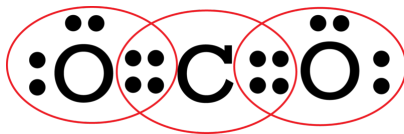

Notice this time that each atom is surrounded by 8 electrons.

Example:

Write the Lewis structure for ammonia, NH_3 .

Step 1: Decide which atoms are bounded.

The most likely bonding for this molecule is to have nitrogen as the central atom and each hydrogen bounded to the nitrogen. Therefore, we can start by putting nitrogen in the center and placing the three hydrogen atoms around it.

Step 2: Count all the valence electrons of all the atoms.

The nitrogen atom has five valence electrons, and each hydrogen atom has one. The total number of valence electrons is 8.

Step 3: Place two electrons between each pair of bounded atoms, as seen in the middle drawing of the figure below.

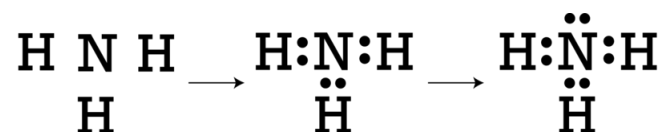

Step 4: Complete all the octets or duets of the atoms attached to the central atom.

In this case, all the non-central atoms are hydrogen, and they already have a duet of electrons.

Step 5: Place any remaining electrons on the central atom.

There are still two electrons left, so they would complete the octet for nitrogen. If the central atom, at this point, does not have an octet of electrons, we would look for places to create a double or triple bond, but that is not the case here. The final drawing on the right in the figure above is the Lewis structure for ammonia.

Example:

Write the Lewis structure for nitric acid, HNO_3 .

Solution:

The skeleton for nitric acid has the three oxygen atoms bounded to the nitrogen and the hydrogen bounded to one of the oxygen atoms, as seen in diagram 1 shown below. The total number of valence electrons is $5 + 6 + 6 + 6 + 1 = 24$.

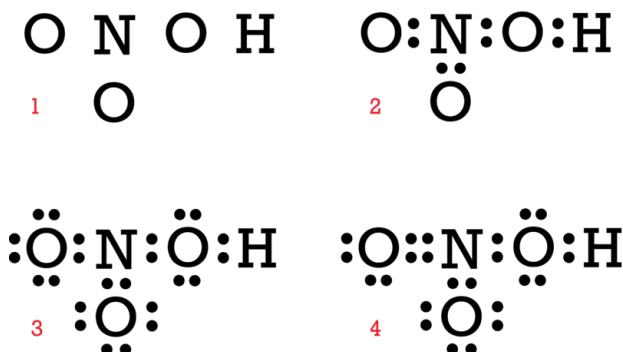

The next step, shown in diagram 2, is to put in a pair of electrons between each bonded pair. So far, we have accounted for 8 of the 24 valence electrons. The next step is to complete the octet or duet for each of the non-central atoms, as seen in diagram 3. At that point, we have used all of the valence electrons, but the central atom does not have an octet of electrons. The rules tell us to find a place to put a double or triple bond. Based on what we have learned up to this point, any of the three oxygen atoms is just as good as the others for participating in a double bond. For this example, we moved two of the electrons from the oxygen atom on the far left between the oxygen

and nitrogen. Now every atom in the molecule has the appropriate octet or duet of electrons. We have a satisfactory Lewis structure for the nitric acid molecule.

For an introduction to drawing Lewis electron dot symbols (2e), see <http://www.youtube.com/watch?v=y6QZRBIO0-o> (4:19).

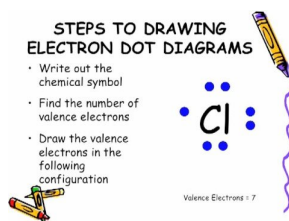

MEDIA

Click image to the left for more content.

Coordinate Covalent Bond

A variation of covalent bonding is coordinate covalent bonding. **Coordinate covalent bonds** form when the two shared electrons of a covalent bond are both donated by the same atom. So far, we have looked at covalent bonds formed by the overlap of two half-filled orbitals. A coordinate covalent bond is different in that it involves the overlap of one full orbital and one empty one. Once formed, a coordinate covalent bond is no different from an ordinary covalent bond. The difference is simply in the source of the electrons forming the bond. You should note that the bond still involves only one pair of electrons and one pair of orbitals, but only one atom provides both of the shared electrons. Many polyatomic ions include coordinate covalent bonds. The ammonium ion is an example of this type of bonding. When hydrogen chloride gas and ammonia gas are brought into contact with each other, they form ammonium chloride, NH_4Cl . When ammonium chloride is dissolved in water, ammonium ions and chloride ions are produced.

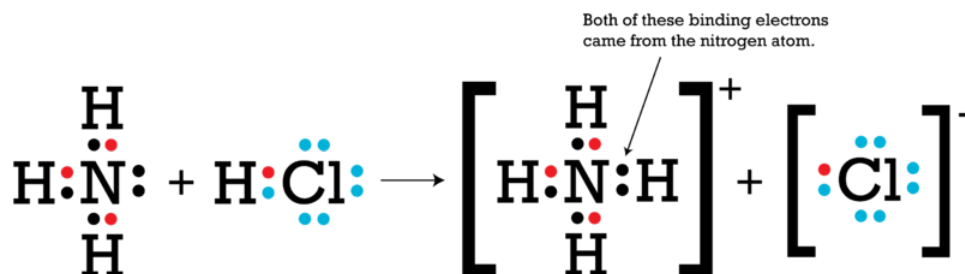
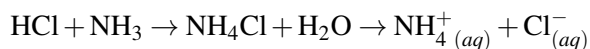

In one of the nitrogen-hydrogen bonds, both electrons came from the nitrogen atom. However, once the ammonium ion has been formed, all four nitrogen-hydrogen bonds are identical, regardless of where the electrons in the bonds came from.

Resonance

Sometimes, more than one valid Lewis structure is possible for the same molecule. Consider the Lewis structure for the nitrite ion, NO_2^- . The charge on the ion indicates an electron has been gained from an external source. In other words, the ion contains an electron that did not originally belong to the nitrogen or the oxygen atoms in the ion. In this case, the -1 charge indicates that the valence electron count will have one additional electron added in order to account for the electron that came from outside the ion. The total number of valence electrons for this ion

is $5 + 6 + 6 + 1 = 18$. We can then draw the Lewis structure for this ion following the normal rules. Before applying the last rule of creating double or triple bonds, the incomplete Lewis structure will look like that in the figure below.



All 18 of the available valence electrons have been used. The final rule for writing Lewis structures states that if the central atom does not have an octet of electrons, double or triple bonds need to be created. In this case, either one of the nitrogen-oxygen bonds can be made into a double bond, as demonstrated in the figure below.



The two structures in the image above suggest that one of the nitrogen-oxygen bonds should be shorter and stronger than the other one. It has been experimentally shown, however, that the two nitrogen-oxygen bonds are identical. In fact, the nitrogen-oxygen bond lengths are about halfway between the expected values for a single bond and a double bond. Neither of the Lewis structures above matches the experimental evidence, and there is no good way to write one that does. The solution to this problem is the use of a concept called **resonance**. Resonance is the condition where there is more than one valid Lewis structure can be written for the molecule or ion. The actual structure of the molecule or ion is actually a composite, or average, of all the valid Lewis structures. In the case of the nitrite ion above, the second pair of electrons in the double bond is actually shared between all the atoms, giving each bond the strength of about 1.5 bonds. Each of the Lewis structures that is drawn is called a resonance structure, with the actual structure being a resonance hybrid of all the contributing structures.

Resonance is also present in the Lewis structures for nitrate ion, NO_3^- .

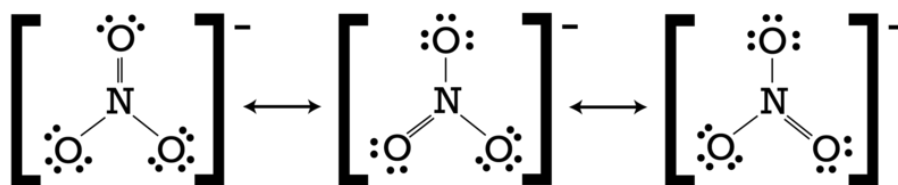

All of these are valid Lewis structures, but none of them accurately portray the structure of the ion. Just like in the case of nitrite, the actual nitrate ion is an average of all three structures. All three nitrogen-oxygen bonds are identical, and they are all slightly shorter and stronger than a normal nitrogen-oxygen single bond. We saw earlier that the second bond in a double bond is a pi bond, created by two *p* orbitals lining up side by side. It is those pi electrons that cannot be described well by a single Lewis structure. Rather than creating a true pi bond between just two atoms, the extra electrons are shared among all four atoms.

When the concept of resonance was first introduced, it was thought that the molecule was rapidly switching, or resonating, between the various resonance forms. Although later evidence showed that this is not the case, the term has survived. Note the double headed arrows (\longleftrightarrow) between each structure. Using this type of arrow indicates that the structures shown are resonance structures, implying that the entire figure attempts to describe a single molecule or ion.

Lesson Summary

- Covalent bonds are formed by electrons being shared between two atoms.
- Covalent bonds are formed between atoms with relatively high electronegativity.
- Bond energy is the amount of energy necessary to break the covalent bond and is an indication of the strength and stability of the bond.
- Some atoms are capable of forming double or triple bonds.
- Multiple bonds between atoms require multiple half-filled orbitals.
- End-to-end orbital overlaps are called sigma bonds.
- Side-to-side orbital overlaps are called pi bonds.
- Lewis structures are commonly used to show the valence electron arrangement in covalently bonded molecules.
- Resonance is a condition occurring when more than one valid Lewis structure can be written for a particular molecule. The actual electronic structure is not represented by any one of the Lewis structures but by the average of all of the valid structures.

Further Reading / Supplemental Links

The learner.org website allows users to view the Annenberg series of chemistry videos. You are required to register before you can watch the videos, but there is no charge to register. The video called “Chemical Bonds” explains the differences between ionic and covalent bonds using models and examples from nature.

- http://www.learner.org/vod/vod_window.html?pid=800

This animation explores the differences between ionic and covalent bonding.

- http://www.mhhe.com/physsci/chemistry/animations/chang_7e_esp/bom1s2_11.swf

This website provides more information about the different types of chemical bonding.

- http://www.visionlearning.com/library/module_viewer.php?mid=55

The website below provides a guide to drawing Lewis structures.

- <http://chemed.chem.purdue.edu/genchem/topicreview/bp/ch8/lewis.html#step>

Review Questions

1. Describe the characteristics of two atoms that would be expected to form an ionic bond.
2. Describe the characteristics of two atoms that would be expected to form a covalent bond.
3. If a molecule had a very high bond energy, would you expect it to be stable or unstable?
4. When gaseous potassium ions and gaseous fluoride ions join together to form a crystal lattice, the amount of energy released is 821 kJ/mol. When gaseous potassium ions and gaseous chloride ions join together to form a crystal lattice, the amount of energy released is 715 kJ/mol. Which bond is stronger, KF or KCl? If these two compounds were increasingly heated, which compound would break apart at the lower temperature?
5. Of the following compounds listed in **Table 11.1**, which would you expect to be ionically bonded and which would you expect to be covalently bonded?

TABLE 11.1: Table for Review Question 5

Compound	Ionic or Covalent
CS ₂	
K ₂ S	
FeF ₃	
PF ₃	
BF ₃	
AlF ₃	
BaS	

- How many sigma bonds and how many pi bonds are present in a triple bond?
- Which of the following molecules will have a triple bond?
 - C₂H₂
 - CH₂Cl₂
 - BF₃
 - CH₃CH₂OH
 - HF
- Draw the Lewis structure for CCl₄.
- Draw the Lewis structure for SO₂.
- Draw a Lewis structure for CO₃²⁻. Explain why all three carbon-oxygen bonds have the same length.

11.2 Covalent Formulas and Nomenclature

Lesson Objectives

The student will:

- list the Greek prefixes from 1 to 10.
- provide the correct formulas for binary covalent compounds.
- name binary covalent compounds using the IUPAC nomenclature system.

Vocabulary

- chemical nomenclature

Introduction

The systematic procedure for naming chemical compounds, or the **chemical nomenclature**, is different for different types of compounds. In the chapter “Ionic Bonds and Formulas,” we have discussed the procedures for naming binary ionic compounds, ionic compounds involving polyatomic ions, and ionic compounds involving metals with variable oxidation states. In this section, we will describe chemical nomenclature for covalently bonded compounds. Because of the large numbers of covalent compounds that may form between the same two elements, the nomenclature system for covalent compounds is somewhat different to the nomenclature system for ionic compounds.

In naming ionic compounds, there is no need to indicate the number of atoms of each element in a formula because, for most cases, there is only one possible compound that can form from the ions present. When aluminum combines with sulfur, the only possible compound is aluminum sulfide, Al_2S_3 . The only exception to this is a few metals with variable oxidation numbers, and these are handled by indicating the oxidation number of the metal with Roman numerals, such as in iron(II) chloride, FeCl_2 .

With covalent compounds, however, we have a very different situation. There are six different covalent compounds that can form between nitrogen and oxygen, and for two of them, nitrogen has the same oxidation number. Therefore, the Roman numeral system will not work. Instead, chemists devised a nomenclature system for covalent compounds that would indicate how many atoms of each element is present in a molecule of the compound.

Greek Prefixes

In naming binary covalent compounds, four rules apply:

1. The first element in the formula is named first using the normal name of the element.

2. The second element is named as if it were an anion. There are no ions in these compounds, but we use the “-ide” ending on the second element as if it were an anion.
3. Greek prefixes, shown in **Table 11.2**, are used for each element to indicate the number of atoms of that element present in the compound.
4. The prefix "mono-" is never used for naming the first element. For example, CO is called carbon monoxide, *not* monocarbon monoxide.

TABLE 11.2: Greek Prefixes

Prefix	Number Indicated
Mono-	1
Di-	2
Tri-	3
Tetra-	4
Penta-	5
Hexa-	6
Hepta-	7
Octa-	8
Nona-	9
Deca-	10

Examples:

N_2O	dinitrogen monoxide
NO	nitrogen monoxide
NO_2	nitrogen dioxide
N_2O_3	dinitrogen trioxide
N_2O_4	dinitrogen tetroxide
N_2O_5	dinitrogen pentoxide
SF_6	sulfur hexafluoride
CO_2	carbon dioxide
P_4O_{10}	tetraphosphorus decaoxide
P_2S_5	diphosphorus pentasulfide

Lesson Summary

- Covalently bonded molecules use Greek prefixes in their nomenclature.

Further Reading / Supplemental Links

This website reviews the rules for naming binary covalent compounds and includes a quiz to test your understanding of these rules.

- http://www.chem.purdue.edu/gchelp/nomenclature/covalent_2009.htm

Review Questions

1. Name the compound CO.
2. Name the compound PCl_3 .
3. Name the compound PCl_5 .
4. Name the compound N_2O_3 .
5. Name the compound BCl_3 .
6. Name the compound SF_4 .
7. Name the compound Cl_2O .
8. Write the formula for the compound sulfur trioxide.
9. Write the formula for the compound dinitrogen tetrafluoride.
10. Write the formula for the compound oxygen difluoride.
11. Write the formula for the compound dinitrogen pentoxide.
12. Write the formula for the compound sulfur hexafluoride.
13. Write the formula for the compound tetraphosphorus decaoxide.

11.3 Electronic and Molecular Geometry

Lesson Objectives

The student will:

- identify the most likely type of bonding (ionic, covalent, or polar covalent) for each compound given binary formulas and an electronegativity chart.
- draw Lewis structures for simple molecules that violate the octet rule.
- from a list of binary compounds, identify those that require electron promotion in the explanation of their bonding.
- identify the type of hybridization in various molecules.
- explain the necessity for the concept of hybridized orbitals.

Vocabulary

- electron promotion
- orbital hybridization
- polar covalent bonds

Introduction

In your study of chemistry, you may have noticed occasionally that after you have learned the “rules” for how matter behaves, you are introduced to the exceptions. For example, shortly after you learned the filling order rule for electron configuration, you were introduced to the exceptions caused by the slightly lower potential energy when the *d* orbitals were exactly half-filled or completely filled. Shortly after you learned that metals lose all their valence electrons when forming ions, you were introduced to some variable oxidation number metals that give up a different number of electrons.

In this section, you will be introduced to exceptions to the octet rule. Most of the exceptions to rules in chemistry are due to the fact that the behavior of matter is controlled by the tendency toward lowest potential energy. Therefore, when a small variation to the rule produces slightly lower potential energy, matter will follow that path.

Electronegativity

Recall from the chapter on “Chemical Periodicity” that the ability for an atom in a molecule to attract shared electrons is called electronegativity. The electronegativity of atoms has been quantified in several ways. One method that is widely accepted is that of Linus Pauling. The Pauling electronegativity values are shown below.

Pauling Electronegativity Values

1 H 2.20																	5 B 2.04	6 C 2.55	7 N 3.04	8 O 3.44	9 F 3.98	
3 Li 0.98	4 Be 1.57																	13 Al 1.61	14 Si 1.90	15 P 2.19	16 S 2.58	17 Cl 3.16
11 Na 0.93	12 Mg 1.31	19 K 0.82	20 Ca 1.00	21 Sc 1.36	22 Ti 1.54	23 V 1.63	24 Cr 1.66	25 Mn 1.55	26 Fe 1.83	27 Co 1.88	28 Ni 1.91	29 Cu 1.90	30 Zn 1.65	31 Ga 1.81	32 Ge 2.01	33 As 2.18	34 Se 2.55	35 Br 2.96				
37 Rb 0.82	38 Sr 0.95	39 Y 1.22	40 Zr 1.33	41 Nb 1.6	42 Mo 2.16	43 Tc 1.9	44 Ru 2.2	45 Rh 2.28	46 Pd 2.20	47 Ag 1.93	48 Cd 1.69	49 In 1.78	50 Sn 1.96	51 Sb 2.05	52 Te 2.1	53 I 2.66						
55 Cs 0.79	56 Ba 0.89	57 La 1.1	72 Hf 1.3	73 Ta 1.5	74 W 2.36	75 Re 1.9	76 Os 2.2	77 Ir 2.20	78 Pt 2.28	79 Au 2.54	80 Hg 2.00	81 Tl 1.62	82 Pb 2.33	83 Bi 2.02	84 Po 2.0	85 At 2.2						
87 Fr 0.7	88 Ra 0.9																					

When two atoms combine, the difference between their electronegativities is an indication of the type of bond that will form. If the difference between the electronegativities of the two atoms is small, neither atom can take the shared electrons completely away from the other atom, and the resulting bond will be covalent. If the difference between the electronegativities is large, the more electronegative atom will take the bonding electrons completely away from the other atom (electron transfer will occur), and the bond will be ionic. There is no exact number for the difference in electronegativity that will produce an ionic bond, but many chemists suggest 1.7 as the approximate difference that will produce an ionic bond.

If we compare a few electronegativities, we can see that 1.7 is a reasonable suggestion. The difference between the electronegativities of hydrogen and oxygen is 1.2, and we know the bonds in the water molecule are covalent. In magnesium chloride, the electronegativity difference is 1.8, and we know this molecule contains ionic bonds.

This video describes ionic, covalent, and polar covalent bonds and relates the types of bonds formed to the differences in electronegativity of the bonding atoms (**2g**): <http://www.youtube.com/watch?v=tSG4R4YZUW8> (5:17).

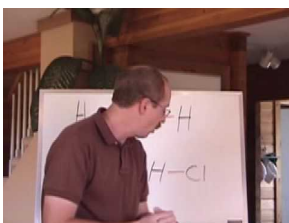

MEDIA

Click image to the left for more content.

The Partial Ionic Character of Covalent Bonds

So far, we have discussed two extreme types of bonds. One case is when two identical atoms bond. They have exactly the same electronegativities, thus the two bonded atoms pull exactly equally on the shared electrons. The other case is when the bonded atoms have a very large difference in their electronegativities. In this case, the more electronegative atom will take the electrons completely away from the other atom, forming an ionic bond.

What about the molecules whose electronegativities are not the same but the difference is not as large as 1.7? For these molecules, the electrons are still shared by the two atoms, but they are not shared equally. The shared electrons are pulled closer to the more electronegative atom. This results in an uneven distribution of electrons over the

molecule and causes slight charges on opposite ends of the molecule. Such molecules are said to have a dipole or are called polar molecules (see figure below). These charges are not full +1 and -1 charges, but rather they are fractions of charges. For small fractions of charges, we use the symbols δ^+ and δ^- .

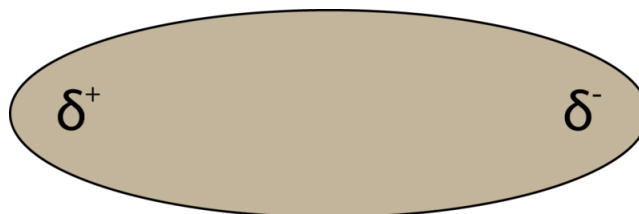

Atoms whose electronegativities are not the same but are not different enough to cause complete electron transfer will form **polar covalent bonds**. These polar covalent bonds will be discussed in more detail later on in this chapter. With the introduction of the polar covalent bond, we now know of three different types of bonds.

In the figure below, molecule A represents a perfectly covalent bond that would form between identical atoms. Molecule B is a polar covalent bond formed between atoms whose electronegativities are not the same but whose electronegativity difference is less than 1.7, while molecule C is an ionic bond formed between atoms whose electronegativity difference is greater than 1.7.

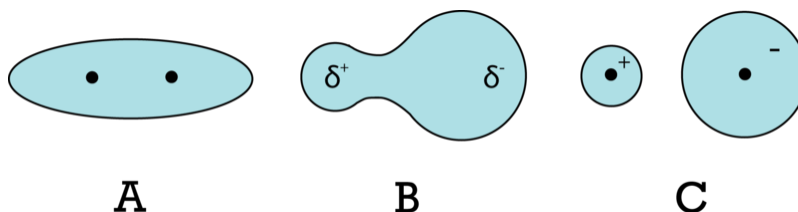

For an introduction to polar bonds see these two videos. The first video defines polar bonds. The second one consists of lecture and animation about polar bonds and polar molecules (**2b**, **2f**): <http://www.youtube.com/watch?v=rRoLSBeOjME> (1:49), <http://www.youtube.com/watch?v=LKAjTE7B2x0> (4:43).

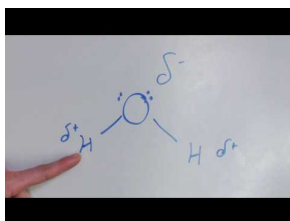

MEDIA

Click image to the left for more content.

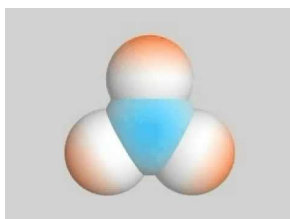

MEDIA

Click image to the left for more content.

Electron Promotion

Consider the molecule formed by the combination of beryllium and hydrogen, beryllium hydride (BeH_2). The electronegativity difference between these two atoms is only 0.6, with beryllium being slightly more electropositive. Therefore, the bonds in BeH_2 are polar covalent bonds. The Lewis structure for the molecule is:



The first thing we might notice about the BeH_2 molecule is that it does not obey the octet rule. Beryllium has two valence electrons and each hydrogen has one, so there are not enough valence electrons to produce an octet around the beryllium atom.

There is also another unusual thing about BeH_2 . The orbital representation for the electron configuration of beryllium shows the $2s$ orbital is full. Earlier in this chapter, we said that the atoms involved in covalent bonding must each have a half-filled orbital. How can beryllium form two bonds when it does not have any half-filled orbitals? The explanation to this question involves the concept of **electron promotion**. As illustrated below, by promoting an electron from the $2s$ orbital to one of the $2p$ orbitals, beryllium theoretically acquires two half-filled orbitals. These half-filled orbitals are therefore able to form two covalent bonds. The amount of necessary to promote an electron from a $2s$ orbital to a $2p$ orbital is small compared to the amount of energy released when beryllium forms two covalent bonds. As a result, in exchange for a small input of energy, a large quantity of energy released.

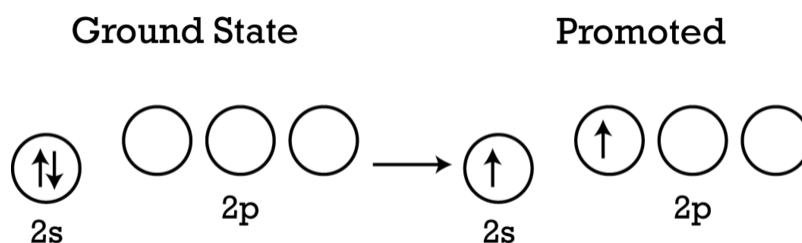

Orbital Hybridization

We have not, however, completed the explanation as to why BeH_2 does not follow the octet rule. Bonds formed by overlapping s orbitals are, in general, shorter, stronger, and more flexible than bonds formed by overlapping p orbitals from the same shell. Therefore, when considering the two bonds in BeH_2 , it would be reasonable to assume that we could determine which bond was formed by hydrogen overlapping with beryllium's half-filled $2s$ orbital and which was formed by hydrogen overlapping beryllium's half-filled $2p$ orbital. Examination of the two bonds, however, shows them to be identical in length, strength, and flexibility. The values for the length, strength, and flexibility also fall in between the values expected for overlapping s and p orbitals. The concept used to explain these observations is called **orbital hybridization**.

In orbital hybridization, all the orbitals involved in bonding are hybridized and form a set of identical orbitals that have properties intermediate to the properties of the orbitals from which they were created.

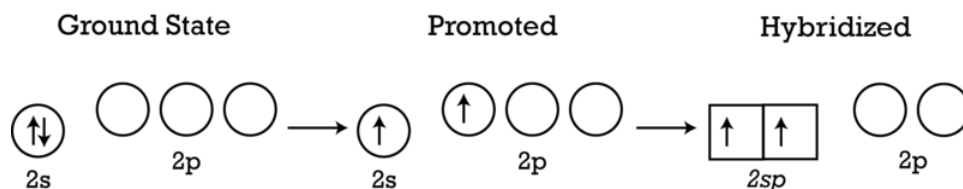

As seen in the image above, the half-filled $2s$ and $2p$ orbitals hybridize to form two completely new orbitals named sp hybridized orbitals. These two new orbitals are identical to each other, and both have characteristics somewhere between the characteristics of $2s$ and $2p$ orbitals. When these half-filled sp hybridized orbitals overlap with the hydrogen atoms, two identical bonds are produced.

Covalent Bonds of Group 3A

The only member of Group 3A that forms a significant number of covalent compounds is boron. Numerous boron compounds exist, with boron forming three bonds in many of the compounds. Since the ground state electron configuration of boron, $1s^2 2s^2 2p^1$, has a filled $2s$ orbital and one half-filled $2p$ orbital, the concept of electron promotion is needed to explain boron's formation of three bonds.

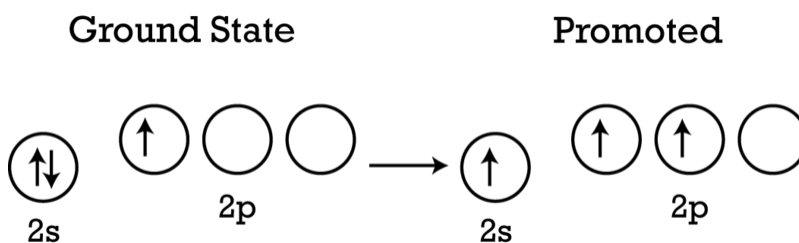

One of the electrons in the $2s$ orbital is promoted to an empty $2p$ orbital, producing three half-filled orbitals that allows boron to form three covalent bonds (illustrated in the figure above). The three bonds in boron compounds such as BH_3 are found to be identical in length, strength, and flexibility. The $2s$ orbital and two $2p$ orbitals hybridize to form three identical sp^2 hybridized orbitals.

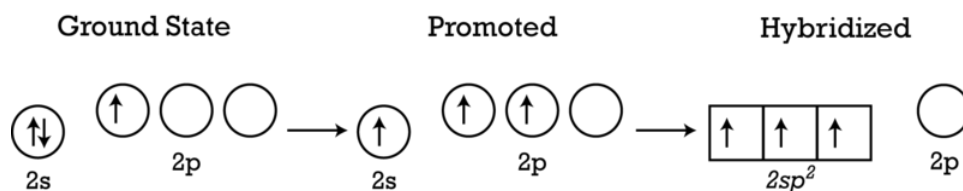

The three hybridized orbitals can now overlap with other atoms and form three identical bonds, making compounds such as BH_3 and BCl_3 . In these boron compounds, the central atom is surrounded by only six electrons, and therefore this is another exception to the octet rule.

It should be recognized that the sp^2 hybridized orbitals are not the same as sp hybridized orbitals. If you mix one bucket of blue paint with one bucket of yellow paint, you get green paint. If you mix two buckets of blue with one bucket of yellow, you will also get green paint, but it will not be the same shade of green as before. Hybridizing one s and one p orbital does not produce the same orbitals as hybridizing one s and two p orbitals.

Covalent Bonds of Group 4A

The members of Group 4A that form covalent bonds are carbon and silicon. Their electron configurations are $1s^2 2s^2 2p^2$ and $1s^2 2s^2 2p^6 3s^2 3p^2$, respectively. In the outer energy level of both atoms, the s orbital is filled, two of the p orbitals are half-filled, and the third p orbital is empty. In the majority of the covalent compounds containing carbon and silicon, these atoms are found to have four bonds. As a result, electron promotion must also occur in these atoms. If one of the electrons in the s orbital is promoted to the empty p orbital, four half-filled orbitals are produced, as shown in the image below.

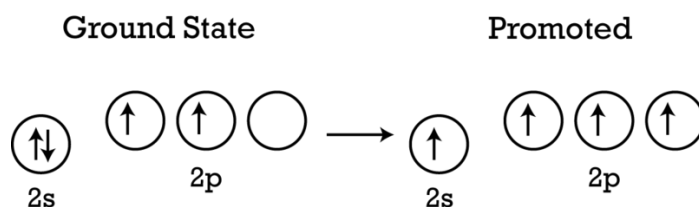

With four half-filled orbitals, carbon and silicon can form the four covalent bonds necessary to create CH_4 , CCl_4 , and so on. As you may have already suspected, the four bonds in carbon and silicon compounds are all identical. Therefore, orbital hybridization also occurs in this family. The four hybridized orbitals, as shown below, are called sp^3 hybridized orbitals.

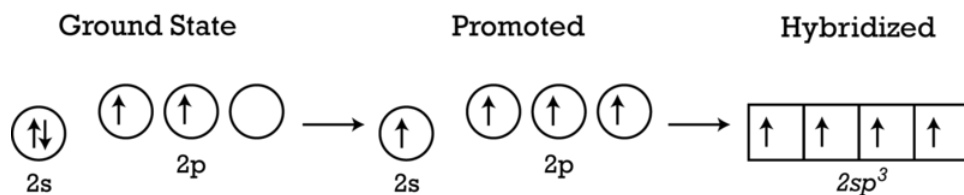

Since the sp^3 hybridized orbitals are a mix of one s and three p orbitals, their characteristics are not the same as sp^2 hybridized orbitals or sp hybridized orbitals. These four identical orbitals can be overlapped by four hydrogen atoms and form four identical bonds. Consequently, the covalent compounds in Group 4A do obey the octet rule.

Covalent Bonds of Group 5A

In Group 5A, the electron configuration of the outermost energy level is $s^2 p^3$. These atoms have three half-filled p orbitals available for bonding and would appear to form three covalent bonds with no need for either electron promotion or hybridization. The first member of the family, nitrogen, commonly forms three bonds in compounds such as NH_3 , NCl_3 , and N_2O_3 . The second member of the family, phosphorus, also forms similar compounds, like PH_3 and PCl_3 . Phosphorus, however, can also form compounds with five covalent bonds, such as PCl_5 . In order to explain five identical bonds for the phosphorus atom, we will need to use the concepts of electron promotion and orbital hybridization.

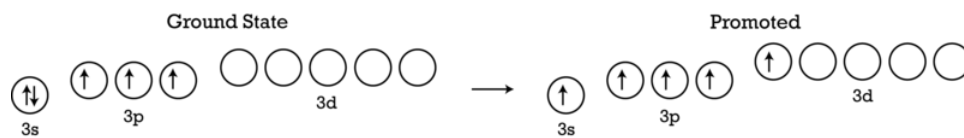

As shown in the figure above, phosphorus promotes one of its 3s electrons into an orbital in the 3d sub-level. This gives phosphorus five half-filled orbitals and allows it to form the five bonds in PCl₅ and other phosphorus compounds with five covalent bonds. It also makes it clear why nitrogen does not form compounds with five bonds, because nitrogen does not have a *d* sub-energy level available. The five bonds in these compounds are identical, which means that one *s* orbital, three *p* orbitals, and one *d* orbital hybridize. These hybridized orbitals will be called *sp³d* or *dsp³* hybridized orbitals. Molecules like PCl₅ and PF₅ will have the central atom surrounded by 10 electrons, so this electron promotion produces another group of molecules that do not obey the octet rule.

Covalent Bonds of Group 6A

The outermost energy level of the members of Group 6A has the electron configuration s^2p^4 . This outer energy level has a filled *s* orbital, one filled *p* orbital, and two half-filled *p* orbitals. With two half-filled orbitals available for overlap, all of the members of this family can and do form two covalent bonds. There are, however, some compounds that form more than two covalent bonds. Oxygen has no *d* orbitals, so promotion into the *d* sub-energy level is not possible. Sulfur and larger members of the family, however, do have *d* orbitals that allow for electron promotion.

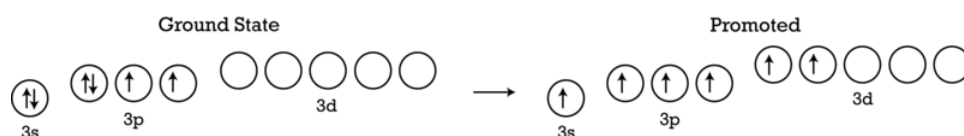

As you can see in the image above, sulfur can promote two electrons into the *d* orbitals and produce six half-filled orbitals available for overlap. The six orbitals are hybridized and form d^2sp^3 or sp^3d^2 hybridized orbitals. Such orbitals are necessary for the formation of compounds such as SF₆.

Covalent Bonds of Group 7A

All of the members of Group 7A have outermost energy level electron configurations s^2p^5 . This configuration has one half-filled *p* orbital, which allows the members of this family to form one covalent bond. The majority of compounds formed by this family contain one bond. Fluorine has no *d* orbitals and can only form one bond. Unlike fluorine, chlorine and the larger members of the family have empty *d* orbitals that allow them to undergo electron promotion. Chlorine can promote one *p* electron to a *d* orbital to produce three half-filled orbitals, which allow compounds like ClF₃ to form. Chlorine can also promote two electrons to form five half-filled orbitals, which results in compounds like ClF₅.

Covalent Bonds of Group 8A

Even members of the noble gases, under extreme conditions, can form some covalent compounds. Since the ground state electron configuration for these atoms has completely filled outer energy levels, the only way that they can form bonds is by electron promotion and orbital hybridization.

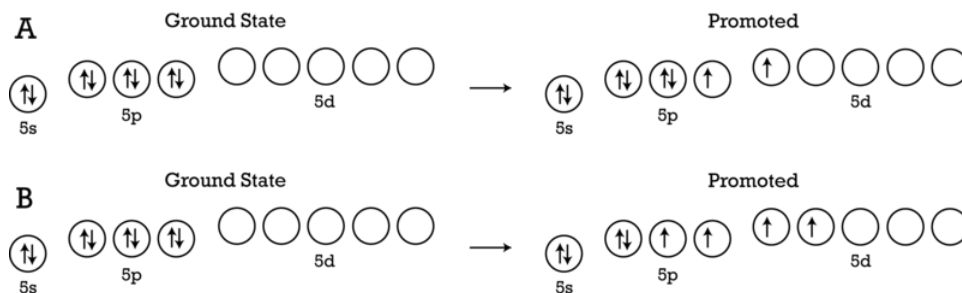

In the diagram above, figure A shows xenon promoting one electron from a p to a d orbital. This allows xenon to form compounds like XeF_2 that contain two covalent bonds. In figure B, xenon is promoting two electrons from p to d orbitals, producing four orbitals available for bonding and forming compounds like XeF_4 . In both Groups 7A and 8A, when electrons are promoted and orbitals are hybridized, even though some of the orbitals are filled and some are half-filled, hybridization is considered to involve *all* the outer energy level orbitals that contain electrons. Therefore, in figure A, the orbital hybridization would be sp^3d , and in figure B, the hybridization would be sp^3d^2 .

Table 11.3 summarizes the different types of hybridized orbitals discussed in this section.

TABLE 11.3: Summary of Hybridized Orbitals

Orbitals Hybridized	Hybridized Orbital Names	Number of Orbitals
$s + p$	sp	2
$s + p + p$	sp^2	3
$s + p + p + p$	sp^3	4
$s + p + p + p + d$	sp^3d	5
$s + p + p + p + d + d$	sp^3d^2	6

This animation reviews the differences in ionic, covalent, and polar covalent bonds (2a): <http://www.youtube.com/watch?v=Kj3o0XvhVqQ> (1:26).

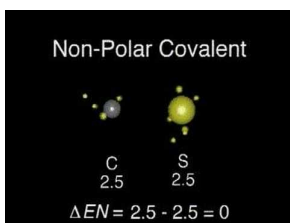

MEDIA

Click image to the left for more content.

Lesson Summary

- A difference of approximately 1.7 or more in the electronegativities of bonded atoms will produce an ionic bond.
- Bonds between atoms whose electronegativity difference is between 0 and 1.7 will be polar covalent.
- A relatively small number of stable molecules do not obey the octet rule.
- Electron promotion occurs within an energy level when an electron from a lower sub-energy level is promoted to a higher sub-energy level.
- The concept involved in orbital hybridization is that all the orbitals of an atom that are involved in bonding are hybridized to orbitals that are identical and have properties intermediate to the properties of the orbitals that are hybridized.
- Covalent bonding in Group 2A involves electron promotion and sp hybridization.

- Covalent bonding in Group 3A involves electron promotion and sp^2 hybridization.
- Covalent bonding in Group 4A involves electron promotion and sp^3 hybridization.
- Covalent bonding in Group 5A involves electron promotion and sp^3d hybridization.
- Covalent bonding in Group 6A involves electron promotion and sp^3d^2 hybridization.
- Covalent bonding in Group 8A involves electron promotion and can involve sp^3d or sp^3d^2 hybridization.

Further Reading / Supplemental Links

The following websites provide more information on electron promotion and orbital hybridization.

- <http://www.mikeblaber.org/oldwine/chm1045/notes/Geometry/Hybrid/Geom05.htm>
- <http://pages.towson.edu/ladon/carbon.html>

This video is a ChemStudy film called “Shapes and Polarities of Molecules.”

- <http://www.youtube.com/watch?v=BnU2idxQ3Xc>

Review Questions

1. Explain the differences among a covalent bond, a polar covalent bond, and an ionic bond.
2. Explain why a pair of atoms form a covalent bond rather than an ionic bond.
3. Predict which of the following bonds will be more polar and explain why: P – Cl or S – Cl.
4. What laboratory evidence necessitates the theory of hybridized orbitals?
5. Which of the following molecules has a central atom with sp^2 hybridized orbitals?
 - a. C_2H_2
 - b. CH_2Cl_2
 - c. BF_3
 - d. CH_3CH_2OH
 - e. HF
6. Fill in the type of hybridization necessary for the following molecules in **Table 11.4**.

TABLE 11.4: Table for Review Question 6

Molecule	Type of Hybridization
H_2O	
NH_3	
$BeCl_2$	
NaH	
BF_3	
PCl_5	
BrF_5	
SF_6	
XeF_2	

Answer questions 7-10 by following the example below.

Example: The formula for boron trichloride is BCl_3 .

a. Draw the electron configuration for the central atom before any electron promotion occurs.

Answer:

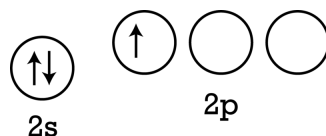

b. Draw the electron configuration for the central atom after any electron promotion occurs.

Answer:

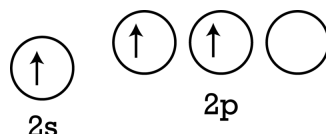

c. Draw the electron configuration after orbital hybridization occurs.

Answer:

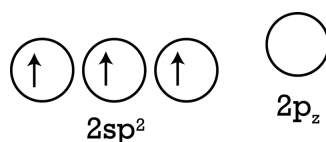

7. The formula for beryllium bromide is BeBr_2 .

- Draw the electron configuration for the central atom before any electron promotion occurs.
- Draw the electron configuration for the central atom after any electron promotion occurs.
- Draw the electron configuration after orbital hybridization occurs.

8. The formula for sulfur hexafluoride is SF_6 .

- Draw the electron configuration for the central atom before any electron promotion occurs.
- Draw the electron configuration for the central atom after any electron promotion occurs.
- Draw the electron configuration after orbital hybridization occurs.

9. The formula for silicon tetrahydride is SiH_4 .

- Draw the electron configuration for the central atom before any electron promotion occurs.
- Draw the electron configuration for the central atom after any electron promotion occurs.
- Draw the electron configuration after orbital hybridization occurs.

10. The formula for phosphorus pentaiodide is PI_5 .

- Draw the electron configuration for the central atom before any electron promotion occurs.
- Draw the electron configuration for the central atom after any electron promotion occurs.
- Draw the electron configuration after orbital hybridization occurs.

11.4 The Geometrical Arrangement of Electrons and Molecular Shape

Lesson Objectives

The student will:

- explain the meaning of the acronym VSEPR and state the concept on which it is based.
- state the main postulate in VSEPR theory.
- use VSEPR theory to predict the three-dimensional shapes of simple covalently bonded molecules.
- explain why we treat multiple bonds as if they were single bonds when are determining molecular geometry.
- identify both the electronic and the molecular geometry for simple binary compounds.

Vocabulary

- electronic geometry
- molecular geometry
- unshared electron pair
- VSEPR theory

Introduction

Many accurate methods now exist for determining molecular structure, the three-dimensional arrangement of the atoms in a molecule. These methods must be used if precise information about structure is needed. However, it is often useful to be able to predict the approximate structure of a molecule. A simple model that allows us to do this is called the **valence shell electron pair repulsion (VSEPR) theory**. This model is useful in predicting the geometries of molecules formed by covalent bonding. The main postulate of this theory is that in order to minimize electron-pair repulsion, the electron pairs around the central atom in a molecule will move as far away from each other as possible.

Central Atom with Two Pairs of Electrons

Consider first the covalent compounds formed by Group 2A. An example of such a compound is BeCl_2 . The central beryllium atom has two pairs of electrons in its valence shell. VSEPR theory tells us that these two pairs of electrons will move as far away from each other as possible. The greatest distance that these two pairs of electrons can get between each other is when the two pairs are 180° apart. Since these two pairs of electrons are involved in bonds with the chlorine atoms, the two chlorines will also be on opposite sides of the nucleus. The electronic geometry in this case is *linear*. Since the electron pairs are involved in bonds, the molecule itself will also be linear. As demonstrated in the figure below, a linear molecule means that a straight line would pass through all the nuclei in the molecule.

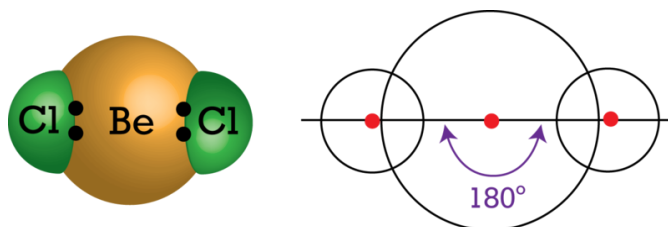

Central Atom with Three Pairs of Electrons

We will look at boron trichloride, BCl_3 , as an example molecule for the covalent molecules in Group 3A. Boron has three valence electrons, with each chlorine that overlaps with a boron orbital contributing one more electron to boron's valence shell. Therefore, boron will have six electrons (three pairs of electrons) in its valence shell. The farthest the three pairs of electrons can move away from each other is to occupy the points of a planar triangle, as illustrated below. Each bond angle will be 120° . This shape is known as *trigonal planar*.

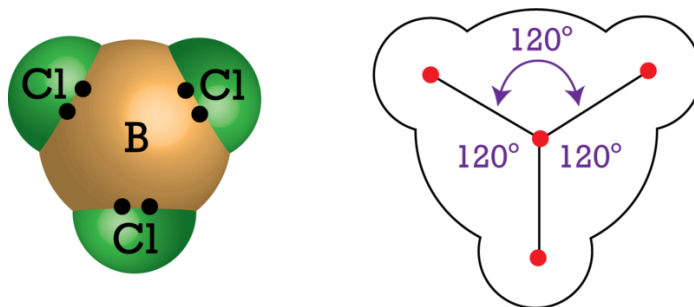

In the trigonal planar shape, all four atoms are in a single plane. None of the atoms project above or below the plane of the paper. You should note that if one pair of electrons is not shared, there will only be two attached chlorine atoms. The shape of such a molecule is called *angular* or *bent*.

Central Atom with Four Pairs of Electrons

Consider methane, CH_4 , as an example of covalent bonding in Group 4A. Carbon has four valence electrons, with each hydrogen adding one more electron so that the central atom in methane has four pairs of electrons in its valence shell. To maximize the distance between them, the four pairs of electrons form a shape called *tetrahedral*. In the tetrahedral shape, the bond angle between any two hydrogen atoms is 109.5° . If all four pairs of electrons are shared, the molecule shape is also tetrahedral.

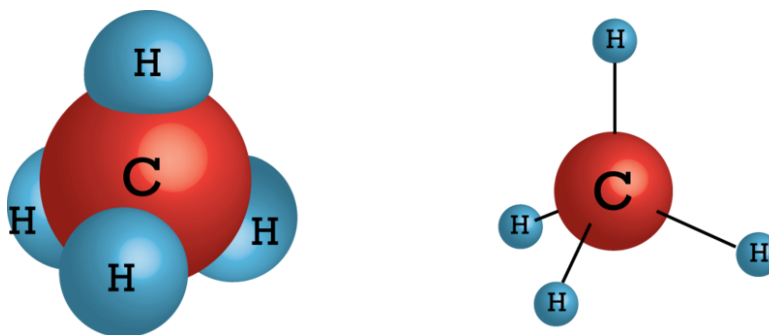

Central Atom with Five Pairs of Electrons

The molecules PCl_3 and PCl_5 will be considered as reference molecules for Group 5A. In the PCl_3 molecule illustrated below, the central phosphorus atom has five valence electrons. Each chlorine atom contributes one more electron, so the central atom has four pairs of electrons in its valence shell. These four pairs of electrons will form the tetrahedral shape in the effort to maximize the distance between them. Therefore, the electronic geometry for this molecule is tetrahedral. When the molecule is formed, however, one of the pairs of electrons is not shared. The resulting molecular geometry is called *pyramidal*.

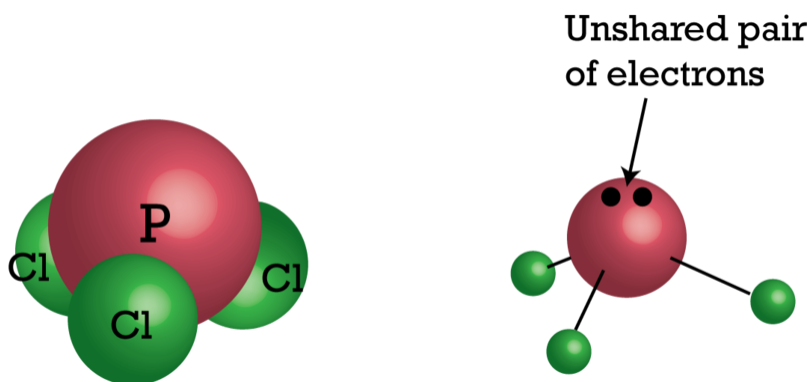

It is important to note the difference between the pyramidal molecule and the trigonal planar molecule discussed earlier. In the trigonal planar molecule, none of the attached atoms is below or above the plane of the central atom. In this pyramidal molecule, however, all three of the attached atoms are below the plane of the central atom.

In the PCl_5 molecule, the phosphorus has five valence electrons, with each chlorine adding one more. As a result, the central atom will be surrounded by five pairs of electrons in its valence shell. When these five pairs of electrons maximize the distance between them, the shape is called *trigonal bipyramidal*. This shape has three attached atoms in a plane with the central atom and two atoms attached to the two ends of the molecule.

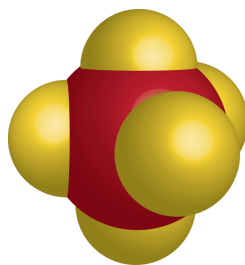

The bond angles between the three atoms in the plane with the central atom are all 120° , while the bond angles between the two end atoms and the other three are 90° .

Central Atom with Six Pairs of Electrons

The two types of electronic geometry in Group 6A can be seen in the molecules SF_2 and SF_6 . In SF_2 , the central sulfur atom has six valence electrons. Each fluorine adds one more, so the central atom is surrounded by four pairs of electrons. The resultant electronic geometry is the tetrahedral shape we have seen before. However, when the compound SF_2 is formed, two of the pairs of electrons are unshared. This molecular shape, shown below, is called angular or bent.

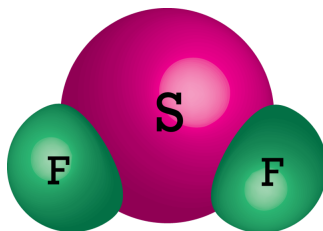

In the molecule SF_6 , sulfur has six valence electrons, with each fluorine contributing another electron so that the central atom is surrounded by six pairs of electrons. The maximum distance six pairs of electrons can separate produces an electronic geometry called *octahedral*.

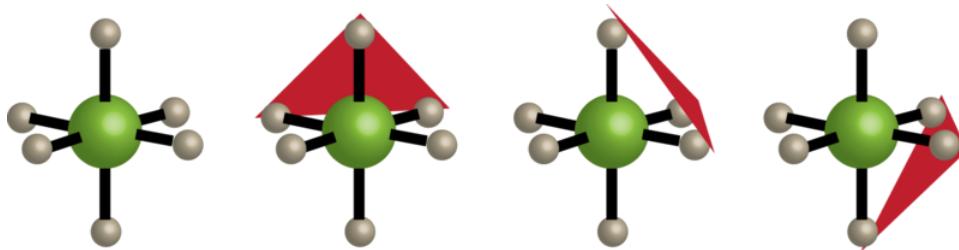

The bond angle between any two adjacent attached atoms is 90° . The shape name is based on the number of triangular plates that can be placed on the surface of the molecule, as illustrated above. If you count carefully, you will see that the surface of the molecule contains eight triangular plates, hence the name octahedral.

Table 11.5 summarizes the electronic geometries that have been presented so far in this chapter.

TABLE 11.5: Summary of Electronic Geometry

Electron Pairs	Hybridization	Electronic Geometry
1	None	Linear
2	sp	Linear
3	sp^2	Trigonal Planar
4	sp^3	Tetrahedral
5	sp^3d	Trigonal Bipyramidal
6	sp^3d^2	Octahedral

Examples of Molecular Shapes

The electronic geometry for a given number of electron pairs surrounding a central atom is always the same. Electron pairs will distribute themselves in the same way to maximize their separation. The same thing cannot be said for molecular geometry. The molecular shape depends on not only the electronic geometry, but also the number of the shared electron pairs. In this section, we will consider a number of examples where some of the electron pairs are not shared.

There are only a few possible molecular geometries available to the members of Group 3A. Consider the shapes of the BH_3 molecule and the BH_2^- ion. In BH_3 molecules, the central atom is surrounded by three pairs of electrons, so the electronic geometry is trigonal planar. When all three electron pairs are shared, the molecular geometry is also trigonal planar, as shown on the left in the diagram below. For the BH_2^- ion, there are still three pairs of electrons around the central atom (3 electrons come from boron, 1 from each of the two hydrogens, and 1 from outside the ion), so the electronic geometry is still trigonal planar. The shape of the ion, however, will be a shape known as bent

or angular, as shown on the right in the diagram below.

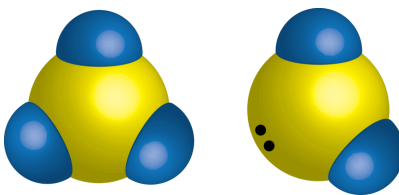

When the central atom is surrounded by four pairs of electrons, the electronic geometry will always be tetrahedral. When all four electron pairs are shared, like in the molecule CH_4 , the molecular shape will also be tetrahedral. In the case of ammonia, NH_3 , only three of the four pairs of electrons are shared. This results in a molecular shape called pyramidal. If a second pair of electrons is unshared, which is the case for H_2O , the shape is angular again. The possible molecular geometries for molecules where the central atom is surrounded by four pairs of electrons are illustrated below.

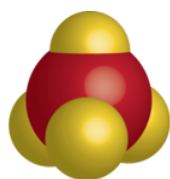

Electronic Geometry: Tetrahedral
All electron pairs shared.
Molecular Geometry: Tetrahedral



Electronic Geometry: Tetrahedral
One unshared pair of electrons.
Molecular Geometry: Pyramidal



Electronic Geometry: Tetrahedral
Two unshared pairs of electrons.
Molecular Geometry: Angular (bent)

When the central atom is surrounded by five pairs of electrons, the electronic geometry is trigonal bipyramidal. If all the electron pairs are shared, the molecular geometry will also be trigonal bipyramidal. An example of such a molecule is PF_5 . If one pair of electrons is not shared, the molecular shape is a *distorted tetrahedron*, which is sometimes called *seesaw*. An example of a molecule with trigonal bipyramidal electronic geometry and a distorted tetrahedron molecular shape is SF_4 . When the electronic geometry is trigonal bipyramidal and two pairs of electrons are unshared, the shape is *T-shaped*. An example of a T-shaped molecule is ClF_3 . ClF_3 has five pairs of electrons around the central atom, but only three of them are shared. When only two electron pairs in the trigonal bipyramidal electronic geometry are shared, the molecular geometry produced is linear, which is the case for I_3^- . The trigonal bipyramidal, distorted tetrahedron, T-shaped, and linear molecular structures are shown in the diagram below.



Electronic Geometry: Trigonal Bipyramidal
All electron pairs shared.
Molecular Geometry: Trigonal Bipyramidal



Electronic Geometry: Trigonal Bipyramidal
One unshared pair of electrons.
Molecular Geometry: Distorted Tetrahedron



Electronic Geometry: Trigonal Bipyramidal
Two unshared pairs of electrons.
Molecular Geometry: T-shaped



Electronic Geometry: Trigonal Bipyramidal
Three unshared pairs of electrons.
Molecular Geometry: Linear

Beginning with octahedral electronic geometry (six pairs of electrons), a number of molecular shapes can be produced depending on the number of electron pairs that are shared and unshared (see the illustration below).

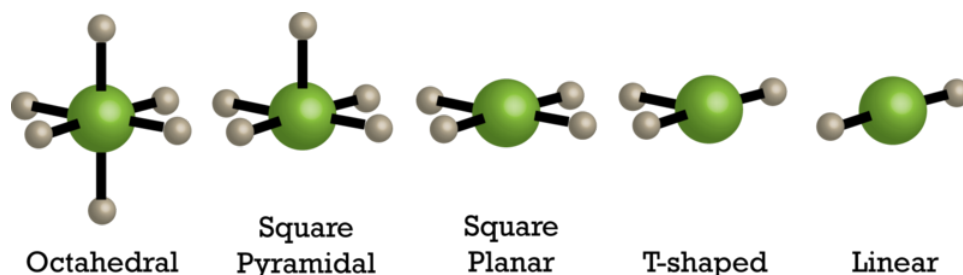

For a trigonal bipyramidal electronic geometry, unshared electron pairs prefer to be in the equatorial positions (the points of the triangle in the “trigonal” plane). For an octahedral electronic geometry, unshared electron pairs prefer to be on opposite sides of the molecule. These rules help rule out other molecular shapes that could potentially occur when dealing with central atoms surrounded by five or six electron pairs.

Table 11.6 summarizes the different molecular geometries.

TABLE 11.6: Summary of Molecular Geometry

Valence Shell Electron Pairs Total	Valence Shell Electron Pairs Shared	Valence Shell Electron Pairs Unshared	Molecular Geometry
1	1	0	Linear
2	2	0	Linear
2	1	1	Linear
3	3	0	Trigonal Planar
3	2	1	Angular
3	1	2	Linear
4	4	0	Tetrahedral
4	3	1	Trigonal Pyramidal
4	2	2	Angular
4	1	3	Linear
5	5	0	Trigonal Bipyramidal
5	4	1	Distorted Tetrahedron
5	3	2	T-shaped
5	2	3	Linear
5	1	4	Linear
6	6	0	Octahedral
6	5	1	Square Pyramidal
6	4	2	Square Planar
6	3	3	T-shaped
6	2	4	Linear
6	1	5	Linear

An animation showing the molecular shapes that are generated by sharing various numbers of electron pairs around the central atom (includes shapes when some pairs of electrons are non-shared pairs).

The Effect of Pi Bonds

For the process of predicting electronic or molecular geometry, double bonds and triple bonds should be counted as one effective pair when determining the number of electron pairs around the central atom. In order to repel other electron pairs, the electron pairs must be placed between the nuclei of two atoms. In pi bonds, the electron density is above and below the plane of the bond and therefore does not contribute to electron pair repulsion. *For the VSEPR model, multiple bonds count as only one effective pair of electrons.* We can use the nitrate ion, NO_3^- , seen below as an example. In order to determine the shape of the nitrate ion, we count the number of electron pairs that are surrounding the central nitrogen atom. Since double bonds count as a single electron pair for the VSEPR model, we would count three pairs of electrons in the central atom's valence shell, and the shape of the ion would be trigonal planar.

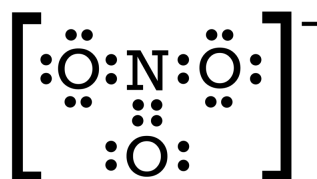

Examples of Determining Molecular Geometry

Example:

Determine the shape of the ammonium ion, NH_4^+ .

Solution:

First determine the number of electron pairs around the central nitrogen atom.

Electrons = 5 (from nitrogen) + 4 (one from each hydrogen) – 1 (the positive charge on the ion indicates this ion has lost one electron to the outside) = 8 electrons = 4 electron pairs

The next step is to choose the electronic geometry based on the number of electron pairs.

The electronic geometry of a central atom with four pairs of electrons = tetrahedral.

Finally, choose the molecular geometry based on the number of valence shell electron pairs that are shared and not shared.

Since all four pairs of electrons are shared in this ion, the ionic shape will be tetrahedral, as seen below.

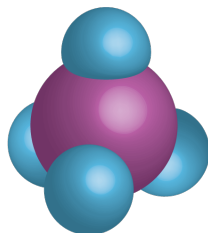
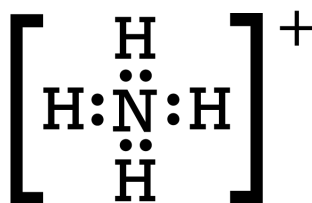
**Example:**

Determine the molecular shape of the PF₅ molecule.

Solution:

Electrons in the valence shell of phosphorus = 5 (phosphorus) + 5 (one from each fluorine) = 10 electrons = 5 pairs of electrons.

The electronic geometry is trigonal bipyramidal. Because all five pairs of electrons are shared, the molecular geometry will also be trigonal bipyramidal, illustrated below.

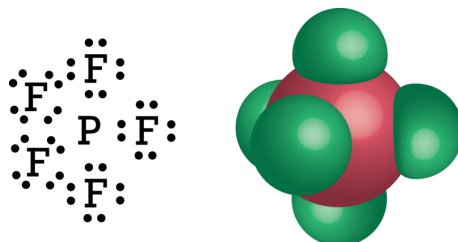
**Example:**

Determine the shape of the ICl₃ molecule.

Solution:

The number of electrons surrounding the central iodine atom 10: 7 electrons come from the iodine atom, and 1 electron comes from each chlorine atom. As a result, there are 10 electrons, or 5 electron pairs, surrounding the central iodine atom. Therefore, the electronic geometry is trigonal bipyramidal. Since only three of the electron pairs are shared, the molecular geometry is T-shaped.

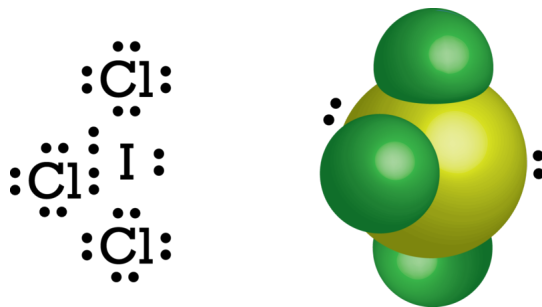

Example:

Determine the shape of the CO₂ molecule.

Solution:

Since there are multiple bonds involved in this molecule, we need to write the Lewis structure for the molecule to make sure we do not count any double or triple bonds for VSEPR model determinations. The Lewis structure for CO₂ is shown below.



Only the sigma bonds count in determining the electron pairs surrounding the central carbon atom. This molecule, therefore, has two electron pairs in the valence shell of the central atom, which produces linear electronic geometry. Since both pairs are shared, the molecular geometry will also be linear.

Example:

Determine the shape of the SO₂ molecule.

Solution:

We will write the Lewis structure (shown below) to check for multiple bonds.



In writing the Lewis structure for SO₂, we determined that a double bond is necessary to provide an octet of electrons for the central sulfur atom. Therefore, this molecule has three pairs of electrons around the central atom, so its electronic geometry will be trigonal planar. Since only two of the electron pairs are shared, the molecular geometry is angular.

Example 6:

Determine the molecular shape of the XeF₄ molecule.

Solution:

The number of electrons surrounding the central atom in XeF₄ is twelve: eight electrons from the Xe, and one each from the four fluorine atoms. As a result, there are twelve electrons, or six electron pairs, around the central atom Xe. Six pairs of electrons around the central atom produces an octahedral electronic geometry. Since two pairs are unshared, the molecular geometry will be square planar.

Lesson Summary

- VSEPR theory suggests that the valence shell electron pairs will spread themselves around the central atom in an attempt to maximize the distance between them due to electrostatic repulsion.
- The electronic geometry of a molecule is dependent only on the number of electron pairs in the valence shell of the central atom.
- Molecular geometry is dependent on the electronic geometry and on the number of electron pairs that are unshared.
- Electrons in pi bonds do not contribute to electronic and molecular geometry.

Further Reading / Supplemental Links

The *learner.org* website allows users to view the Annenberg series of chemistry videos. You are required to register before you can watch the videos, but there is no charge to register. The video called “Molecular Architecture” is related to this lesson.

- <http://learner.org/resources/series61.html>

This website reviews how to predict molecular structure by using the VSEPR theory.

- http://www.up.ac.za/academic/chem/mol_geom/mol_geometry.htm

This video is a ChemStudy film called “Shapes and Polarities of Molecules.”

- <http://www.youtube.com/watch?v=BnU2idxQ3Xc>

Review Questions

1. What is the designation for the hybrid orbitals formed from each of the following combinations of atomic orbitals in **Table 11.7**, and what is the bond angle associated with the hybrid orbitals?

TABLE 11.7: Table for Review Question 1

Orbitals Combined	Type of Hybridization	Bond Angles
one <i>s</i> and one <i>p</i>		
one <i>s</i> and two <i>p</i>		
one <i>s</i> and three <i>p</i>		

2. Draw a Lewis structure for OF_2 that obeys the octet rule.
3. Draw a Lewis structure for H_2CO that obeys the octet rule. (C is the central atom.) What is the geometrical shape of this molecule?
4. What is the bond angle in SCl_2 ?
5. What is the molecular shape of ICl_3 ?
6. What is the molecular shape of XeCl_4 ?
7. The ion I_3^- molecule has been produced in the lab, but the ion F_3^- has not. Offer an explanation as to why F_3^- cannot be produced in the lab.
8. The molecule shown here is formaldehyde. What is the hybridization of the carbon atom in this molecule?

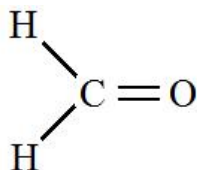

- a. sp^2
- b. sp^2d
- c. sp^3
- d. 5 pi bonds

9. The molecule shown here is acetylsalicylic acid, better known as aspirin.

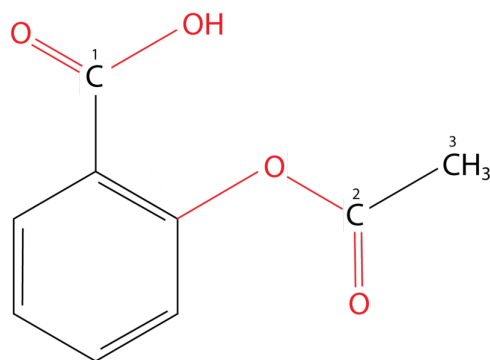

- What is the hybridization of carbon 1?
- What is the hybridization of carbon 2?
- What is the hybridization of carbon 3?
- What is the total number of pi bonds in the molecule?

All images, unless otherwise stated, are created by the CK-12 Foundation and are under the Creative Commons license CC-BY-NC-SA.

CHAPTER 12**The Mole Concept****Chapter Outline**

- 12.1 DETERMINING FORMULA AND MOLAR MASSES**
 - 12.2 THE MOLE**
 - 12.3 PERCENT COMPOSITION**
 - 12.4 EMPIRICAL AND MOLECULAR FORMULAS**
-

12.1 Determining Formula and Molar Masses

Lesson Objectives

The student will:

- calculate the formula mass of a compound given its name and a periodic table.

Vocabulary

- formula mass
- molecular mass

Introduction

When atoms of one element chemically combine with atoms of another element, a compound is formed. Compounds have names and formulas associated with them. The formula of a compound contains chemical symbols that tell us what elements are in the compound. The subscripts in the formula tell us the ratios of the elements present. For example, the formula MgCl_2 tells us that this compound is composed of the elements magnesium and chlorine, which combine in the ratio of two atoms of chlorine for each atom of magnesium. Using the formula of the compound and the relative masses of elements from the periodic table, we can then calculate the relative formula mass for the compound.

Formula Mass

The periodic table tells us the relative masses of all the elements. Looking at the squares for carbon and helium, we can see that a carbon atom has about three times the mass of a helium atom. In this way, we can compare the relative masses of any two atoms in the table. By looking at the chemical formulas and the relative atomic masses, we can also compare the masses of different compounds. The **formula mass** of a compound is the sum of all the atomic masses in the formula. The formula for water, for example, is H_2O . This formula tells us that water is composed of hydrogen and oxygen and has a ratio of two hydrogen atoms for each oxygen atom. We can determine the formula mass for water by adding up the atomic masses of its components.

Example:

What is the formula mass of H_2O ?

Solution:

Element	Atomic Mass	Number of Atoms per Formula	Product
H	1.0 daltons	2	2.0 daltons
O	16.0 daltons	1	<u>16.0 daltons</u>
			18.0 daltons

The formula mass of $\text{H}_2\text{O} = 18.0$ daltons.

Example:

What is the formula mass of $\text{Ca}(\text{NO}_3)_2$?

Solution:

Element	Atomic Mass	Number of Atoms per Formula	Product
Ca	40.0 daltons	1	40.0 daltons
N	14.0 daltons	2	28.0 daltons
O	16.0 daltons	6	<u>96.0 daltons</u>
			164.0 daltons

The formula mass of $\text{Ca}(\text{NO}_3)_2 = 164.0$ daltons.

These formula masses are in the same units as atomic masses and therefore are exactly comparable. For example, the atomic mass of an oxygen atom is 16 daltons, the atomic mass of a fluorine atom is 19 daltons, and the formula mass of a water molecule is 18 daltons. This means that a water molecule is slightly more massive than an oxygen atom and slightly less massive than a fluorine atom.

Terminology

Since ionic compounds do not form individual molecules, the term formula mass is the only proper term to describe this relative mass. In comparison, the formula mass for covalent compounds may also be called the **molecular mass** because covalent compounds do form molecules. While it is important to understand this distinction, no professional chemists have had their degrees in chemistry recalled when they referred to the “molecular mass” of NaCl due to a slip of the tongue.

Lesson Summary

- The molecular mass of a molecule is found by adding the atomic masses of all the atoms in one molecule.
- Not all substances exist as molecules, so the term molecular mass is not used for all substances. The masses of ionic compounds and empirical formulas are called formula mass.

Review Questions

1. Calculate the formula mass for each of the following.
 - a. K_2SO_4
 - b. CuO
 - c. $\text{Mg}_3(\text{AsO}_4)_2$
 - d. $\text{Ca}_3(\text{PO}_4)_2$

- e. Fe_2O_3
 - f. $\text{Al}(\text{OH})_3$
 - g. $(\text{NH}_4)_2\text{S}$
 - h. $\text{C}_{12}\text{H}_{22}\text{O}_{11}$
2. On average, how many times heavier are bromine atoms than neon atoms?
 3. An unknown element, M, combines with oxygen to form a compound with a formula of MO_2 . If 25.0 grams of the unknown element combines with 4.50 grams of oxygen, what is the atomic mass of M?

12.2 The Mole

Lesson Objectives

The student will:

- express the value of Avogadro's number and explain its relevance to moles.
- use Avogadro's number to convert to moles given the number of particles of a substance, and vice versa.
- use the molar mass to convert to grams given the number of moles of a substance, and vice versa.

Vocabulary

- Avogadro's number
- molar mass
- mole

Introduction

When objects are very small, it is often inconvenient, inefficient, or even impossible to deal with one object at a time. For these reasons, we often deal with groups of small objects and even have names for these groups. The most common of these is dozen, which refers to 12 objects. We frequently buy objects in groups of twelve, like doughnuts or pencils. Even smaller objects, such as straight pins or staples, are usually sold in boxes of 144, or a dozen dozen. A group of 144 objects is called a gross.

The problem of trying to deal with very small things individually also occurs in chemistry. Atoms and molecules are too small to see, let alone to count or measure. Chemists needed to select a group of atoms or molecules that would be convenient to operate with.

This video introduces the concept of the mole (3b, 3c): <http://www.youtube.com/watch?v=AsqEkF7hcII> (9:44).

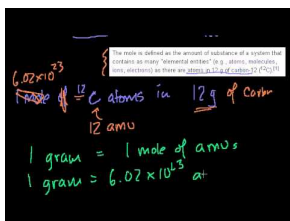

MEDIA

Click image to the left for more content.

Avogadro's Number

In chemistry, it is nearly impossible to deal with a single atom or molecule. Instead, chemists have defined a group of particles that is convenient to work with. Since molecules are extremely small, you might suspect that the number of particles in this group is going to be very large. In fact, the number of particles in this group is 6.02×10^{23} particles, and the name of this group is the **mole** (abbreviated as mol). The number 6.02×10^{23} is called Avogadro's number and is symbolized as the capital letter *N*. Although Italian scientist Amedeo Avogadro did not determine this number, but the number was named in honor of him. One mole of any object contains an Avogadro's number, or 6.02×10^{23} , of those objects.

The number of objects in a mole was not chosen arbitrarily. Instead, there is a very particular reason that the number 6.02×10^{23} was chosen. When chemists carry out chemical reactions, it is important to understand the relationship between the numbers of particles of each element involved in the reaction. Chemists realized that they obtained equal numbers of particles when they used one atomic or molecular mass in grams of the substances. By looking at the atomic masses on the periodic table, chemists knew that the mass ratio of one carbon atom to one sulfur atom was 12 amu to 32 amu. If they measured out one atomic mass in grams of both substances (in other words, 12 grams of carbon and 32 grams of sulfur), they would have the same number of atoms of each element. They didn't know how many atoms were in each pile, but they knew the number in each pile had to be the same. This logic is the same as knowing that if a basketball has twice the mass of a soccer ball, then 100 lbs of basketballs and 50 lbs of soccer balls both contain the same number of balls.

This amount of substance (its molecular mass in grams) became known as a gram-molecular mass. One gram-molecular mass of any substance had the same number of particles in it. Years later, when it became possible to count particles using electrochemical reactions, the number of particles in a gram-molecular mass was counted. That number turned out to be 6.02×10^{23} particles. This number of particles continued to be called a gram-molecular mass for many years, but eventually the name was changed to the mole.

The mole is defined so that 1.00 mole of carbon-12 atoms has a mass of 12.0 grams and contains 6.02×10^{23} atoms. Likewise, 1.00 mole of water has a mass of 18.0 grams and contains 6.02×10^{23} molecules. One mole of any element or compound has a mass equal to its molecular mass in grams and contains 6.02×10^{23} particles. The mass in grams of 6.02×10^{23} particles of a substance is now called the **molar mass** (mass of 1.00 mole).

Converting Molecules to Moles and Vice Versa

We now know that because the mass of a single molecule of H_2SO_4 is 98 daltons, the mass of an Avogadro's number of H_2SO_4 molecules is 98 grams. We can use this information to find the mass in grams of a single H_2SO_4 molecule because we know that 98 grams contains 6.02×10^{23} molecules. If we divide 6.02×10^{23} molecules into 98 grams, we will get the mass of a single H_2SO_4 molecule in grams. After performing this calculation, we would obtain an answer of 1.6×10^{-22} grams/molecule – tiny, indeed. If we are given a number of molecules of a substance, we can convert it into moles by dividing by Avogadro's number, and vice versa.

Example:

How many moles are present in 1,000,000,000 (1 billion or 1×10^9) molecules of water?

Solution:

$$\text{moles} = (1,000,000,000 \text{ molecules}) \cdot \left(\frac{1 \text{ mole}}{6.02 \times 10^{23} \text{ molecules}} \right) = 1.7 \times 10^{-15} \text{ moles}$$

You should note that this amount of water is too small for even our most delicate balances to determine the mass. A *very* large number of molecules must be present before the mass is large enough to be detected with our balances.

Example:

How many molecules are present in 0.00100 mole?

Solution:

$$\text{molecules} = (0.00100 \text{ mole}) \cdot \left(\frac{6.02 \times 10^{23} \text{ molecules}}{1 \text{ mole}} \right) = 6.02 \times 10^{20} \text{ molecules}$$

Unlike the previous example, the mass of 602,000,000,000,000,000,000 can be measured with a balance.

Converting Grams to Moles and Vice Versa

We can also convert back and forth between grams of substance and moles. The conversion factor for this is the molar mass of the substance. To convert the grams of a substance into moles, we divide by the molar mass. To convert the moles of a substance into grams, we multiply by the molar mass.

Example:

How many moles are present in 108 grams of water?

Solution:

$$\text{moles} = \frac{\text{grams}}{\text{molar mass}} = \frac{108 \text{ grams}}{18.0 \text{ grams/mole}} = 6.00 \text{ moles}$$

Example:

What is the mass of 7.50 moles of CaO?

Solution:

$$\text{grams} = (\text{moles}) \cdot (\text{molar mass}) = (7.50 \text{ moles}) \cdot (56.0 \text{ grams/mole}) = 420. \text{ grams}$$

This video tells a story to help students remember the easy way to perform mole conversions (**3d**): <http://www.youtube.com/watch?v=Kg-zaG0ckVg> (2:52).

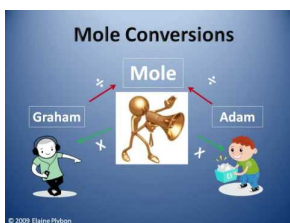

MEDIA

Click image to the left for more content.

Lesson Summary

- There are 6.02×10^{23} particles in 1.00 mole. The number 6.02×10^{23} is called Avogadro's number.
- The number of moles in a given number of molecules of a substance can be found by dividing the number of molecules by Avogadro's number.
- The number of moles in a given mass of substance can be found by dividing the mass by the formula mass expressed in grams/mole.

Further Reading / Supplemental Links

The *learner.org* website allows users to view streaming videos of the Annenberg series of chemistry videos. You are required to register before you can watch the videos, but there is no charge to register. The website has a video that apply to this lesson called "The Mole."

- <http://learner.org/resources/series61.html>

The website below reviews how to calculate the molar mass of chemical compounds.

- <http://misterguch.brinkster.net/molarmass.html>

Review Questions

- Convert the following to moles.
 - 60.0 grams of NaOH
 - 2.73 grams of NH_4Cl
 - 5.70 grams of ZrF_4
 - 10.0 grams of PbO_2
- Convert the following to grams.
 - 0.100 moles of CO_2
 - 0.437 moles of NaOH
 - 0.500 moles of $(\text{NH}_4)_2\text{CO}_3$
 - 3.00 moles of ZnCl_2
- How many molecules (formula units for ionic compounds) are present in the following quantities?
 - 0.250 mole of H_2O
 - 6.00 moles of H_2SO_4
 - 0.00450 mole of $\text{Al}_2(\text{CO}_3)_3$
- How many moles are present in the following quantities?
 - 1.00×10^{20} molecules of H_2O
 - 1.00×10^{25} molecules of H_2
 - 5,000,000,000,000 atoms of carbon
- How many molecules, atoms, or formula units are present in the following masses?
 - 1.00 gram of Na_2CO_3
 - 8.00 grams of helium
 1000. grams of H_2O
- Convert the following to grams.
 - 1.00×10^{23} molecules of H_2
 - 1.00×10^{24} formula units of AlPO_4
 - 1.00×10^{22} formula units of NaOH
- What is the mass of a single atom of silver, Ag, in grams?
- If you determined that the volume of a silver bar is 100. mL, how many atoms of silver would be in the bar?
The density of silver is 10.5 g/mL.

12.3 Percent Composition

Lesson Objectives

The student will:

- calculate the percent composition by mass given the masses of elements in a compound.
 - calculate the percent composition by mass given the formula or name of a compound.
-

Vocabulary

- percent composition
-

Introduction

Metals useful to man are typically extracted from ore. The ore is removed from the mine and partially purified by washing away dirt and other materials not chemically bound to the metal of interest. This partially purified ore is then treated chemically in smelters or other purifying processes to separate pure metal from the other elements. The value of the original ore is very dependent on how much pure metal can eventually be separated from it. High-grade ore and low-grade ore command significantly different prices. The ore can be evaluated before it is mined or smelted to determine what percent of the ore can eventually become pure metal. This process involves determining what percentage of the ore is metal compounds and what percentage of the metal compounds is pure metal.

Percent Composition from Masses

Compounds are made up of two or more elements. The law of definite proportions tells us that the proportion, by mass, of elements in a compound is always the same. Water, for example, is always 11% hydrogen and 89% oxygen by mass. The **percentage composition** of a compound is the percentage by mass of each element in the compound.

Percentage composition can be determined experimentally. To do this, a known quantity of a compound is decomposed in the laboratory. The mass of each element is measured and then divided by the total mass of the original compound. This tells us what fraction of the compound is made up of that element. The fraction can then be multiplied by 100% to convert it into a percent.

Example:

Laboratory procedures show that 50.0 grams of ammonia, NH_3 , yields 41.0 grams of nitrogen and 9.00 grams of hydrogen upon decomposition. What is the percent composition of ammonia?

Solution:

$$\% \text{ nitrogen} = \left(\frac{41.0 \text{ grams}}{50.0 \text{ grams}} \right) \cdot (100\%) = 82\%$$

$$\% \text{ hydrogen} = \left(\frac{9.00 \text{ grams}}{50.0 \text{ grams}} \right) \cdot (100\%) = 18\%$$

Example:

The decomposition of 25.0 grams of $\text{Ca}(\text{OH})_2$ in the lab produces 13.5 grams of calcium, 10.8 grams of oxygen, and 0.68 grams of hydrogen. What is the percent composition of calcium hydroxide?

Solution:

$$\% \text{ calcium} = \left(\frac{13.5 \text{ grams}}{25.0 \text{ grams}} \right) \cdot (100\%) = 54.0\%$$

$$\% \text{ oxygen} = \left(\frac{10.8 \text{ grams}}{25.0 \text{ grams}} \right) \cdot (100\%) = 43.2\%$$

$$\% \text{ hydrogen} = \left(\frac{0.68 \text{ grams}}{25.0 \text{ grams}} \right) \cdot (100\%) = 2.8\%$$

You should note that the sum of the percentages always adds to 100%. Sometimes, the sum may total to 99% or 101% due to rounding, but if it totals to 96% or 103%, you have made an error.

Percent Composition from the Formula

Percent composition can also be calculated from the formula of a compound. Consider the formula for the compound iron(III) oxide, Fe_2O_3 . The percent composition of the elements in this compound can be calculated by dividing the total atomic mass of the atoms of each element in the formula by the formula mass.

Example:

What is the percent composition of iron(III) oxide, Fe_2O_3 ?

Solution:

Element	Atomic Mass	Number of Atoms per Formula	Product
Fe	55.8 daltons	2	111.6 daltons
O	16.0 daltons	3	<u>48.0 daltons</u>
Formula mass =			159.6 daltons

$$\% \text{ iron} = \left(\frac{111.6 \text{ daltons}}{159.6 \text{ daltons}} \right) \cdot (100\%) = 69.9\%$$

$$\% \text{ oxygen} = \left(\frac{48.0 \text{ daltons}}{159.6 \text{ daltons}} \right) \cdot (100\%) = 30.1\%$$

Example:

What is the percent composition of aluminum sulfate, $\text{Al}_2(\text{SO}_4)_3$?

Solution:

The formula mass of $\text{Al}_2(\text{SO}_4)_3$ is: $2 \cdot (27.0 \text{ daltons}) + 3 \cdot (32.0 \text{ daltons}) + 12 \cdot (16.0 \text{ daltons}) = 342.0 \text{ daltons}$

$$\% \text{ aluminum} = \left(\frac{54.0 \text{ daltons}}{342 \text{ daltons}} \right) \cdot (100\%) = 15.8\%$$

$$\% \text{ sulfur} = \left(\frac{96.0 \text{ daltons}}{342 \text{ daltons}} \right) \cdot (100\%) = 28.1\%$$

$$\% \text{ oxygen} = \left(\frac{192 \text{ daltons}}{342 \text{ daltons}} \right) \cdot (100\%) = 56.1\%$$

Lesson Summary

- The percent composition of a compound is the percent of the total mass contributed by each element in the compound.
- Percent composition can be determined either from the masses of each element in the compound or from the formula of the compound.

Further Reading / Supplemental Links

This website has solved example problems for a number of topics covered in this lesson, including the calculation of percent composition by mass.

- <http://www.sciencejoywagon.com/chemzone/05chemical-reactions/>

The website below reviews how to calculate percent composition.

- <http://www.ausetute.com.au/percentc.html>

Review Questions

Determine the percent composition of the following compounds.

1. BF_3
2. $\text{Ca}(\text{C}_2\text{H}_3\text{O}_2)_2$
3. FeF_3
4. CrCl_3
5. $(\text{NH}_4)_3\text{PO}_4$

12.4 Empirical and Molecular Formulas

Lesson Objectives

The student will:

- reduce molecular formulas to empirical formulas.
- determine the empirical formula of a compound given either percent composition or masses.
- determine the molecular formula of a compound given either percent composition and molar mass or masses.

Vocabulary

- molecular formula

Introduction

The empirical formula is the simplest ratio of atoms in a compound. Formulas for ionic compounds are always empirical formulas, but for covalent compounds, the empirical formula is not always the actual formula for the molecule. Molecules such as benzene, C_6H_6 , would have an empirical formula of CH.

Finding Empirical Formula from Experimental Data

Empirical formulas can be determined from experimental data or from percent composition. Consider the following example.

Example:

We find that a 2.50 gram sample of a compound contains 0.900 grams of calcium and 1.60 grams of chlorine. The compound contains only these two elements. We can calculate the number of moles of calcium and chlorine atoms in the compound. We can then find the molar ratio of calcium atoms to chlorine atoms. From this, we can determine the empirical formula.

Solution:

First, we convert the mass of each element into moles.

$$\begin{aligned}\text{moles of Ca} &= \frac{0.900 \text{ g}}{40.1 \text{ g/mol}} = 0.0224 \text{ mol Ca} \\ \text{moles of Cl atoms} &= \frac{1.60 \text{ g}}{35.5 \text{ g/mol}} = 0.0451 \text{ mol Cl}\end{aligned}$$

At this point, we have the correct ratio for the atoms in the compound. The formula $\text{Ca}_{0.0224}\text{Cl}_{0.0451}$, however, isn't acceptable. We need to find the simplest *whole* number ratio. To find a simple whole number ratio for these numbers, we divide each of them by the smaller number.

$$\text{Ca} = \frac{0.0224}{0.0224} = 1.00 \qquad \text{Cl} = \frac{0.0451}{0.0224} = 2.01$$

Now, we can see the correct empirical formula for this compound is CaCl_2 .

Finding Empirical Formula from Percent Composition

When finding the empirical formula from percent composition, the first thing to do is to convert the percentages into masses. For example, suppose we are given that the percent composition of a compound is 40.0% carbon, 6.71% hydrogen, and 53.3% oxygen. Since every sample of this compound will have the same composition in terms of the ratio of atoms, we could choose a sample of any size. Suppose we choose a sample size of 100. grams. The masses of each of the elements in this sample will be 40.0 grams of carbon, 6.71 grams of hydrogen, and 53.3 grams of oxygen. These masses can then be used to find the empirical formula. You could use any size sample, but choosing a sample size of 100. grams is usually most convenient because it makes the arithmetic simple.

Example:

Find the empirical formula of a compound whose percent composition is 40.0% carbon, 6.71% hydrogen, and 53.3% oxygen.

Solution:

We choose a sample size of 100. grams and multiply this 100. gram sample by each of the percentages to get masses for each element. This would yield 40.0 grams of carbon, 6.71 grams of hydrogen, and 53.3 grams of oxygen. The next step is to convert the mass of each element into moles.

$$\begin{aligned} \text{moles of C} &= \frac{40.0 \text{ g}}{12.0 \text{ g/mol}} = 3.33 \text{ moles C} \\ \text{moles of H} &= \frac{6.71 \text{ g}}{1.01 \text{ g/mol}} = 6.64 \text{ moles H} \\ \text{moles of O} &= \frac{53.3 \text{ g}}{16.0 \text{ g/mol}} = 3.33 \text{ mole O} \end{aligned}$$

Then, we divide all three numbers by the smallest one to get simple whole number ratios:

$$\text{C} = \frac{3.33}{3.33} = 1 \qquad \text{H} = \frac{6.64}{3.33} = 2 \qquad \text{O} = \frac{3.33}{3.33} = 1$$

Finally, we can write the empirical formula CH_2O .

Sometimes, this technique of dividing each of the moles by the smallest number does not yield whole numbers. Whenever the subscript for any element in the empirical formula is 1, dividing each of the moles by the smallest will yield a simple whole number ratio, but if none of the elements in the empirical formula has a subscript of 1, then this technique will not yield a simple whole number ratio. In those cases, a little more work is required.

Example:

Determine the empirical formula for a compound that is 66.0% calcium and 34.0% phosphorus.

Solution:

We choose a sample size of 100. grams and multiply the 100. grams by the percentage of each element to get masses. This yields 66.0 grams of calcium and 34.0 grams of phosphorus. We then divide each of these masses by their molar mass to convert the masses into moles:

$$\begin{aligned}\text{moles of Ca} &= \frac{66.0 \text{ g}}{40.1 \text{ g/mol}} = 1.65 \text{ moles Ca} \\ \text{moles of P} &= \frac{34.0 \text{ g}}{31.0 \text{ g/mol}} = 1.10 \text{ moles P}\end{aligned}$$

We then divide each of these moles by the smallest.

$$\text{Ca} = \frac{1.65}{1.10} = 1.50 \qquad \text{P} = \frac{1.10}{1.10} = 1.00$$

In this case, dividing each of the numbers by the smallest one does not yield a simple whole number ratio. In such a case, we must multiply both numbers by some factor that will produce a whole number ratio. If we multiply each of these by 2, we get a whole number ratio of 3 Ca to 2 P. Therefore, the empirical formula is Ca_3P_2 .

Finding Molecular Formulas

Empirical formulas show the simplest whole number ratio of the atoms in a compound. Molecular formulas show the actual number of atoms of each element in a compound. When you find an empirical formula from either masses of elements or from percent composition, you are finding the empirical formula. For the compound N_2H_4 , you will get an empirical formula of NH_2 , and for C_3H_6 , you will get CH_2 . If we want to determine the actual molecular formula, we need one additional piece of information. The molecular formula is always a whole number multiple of the empirical formula. In order to get the molecular formula for N_2H_4 , you must double each of the subscripts in the empirical formula. Since the molecular formula is a whole number multiple of the empirical formula, the molecular mass will be the same whole number multiple of the formula mass. The formula mass for NH_2 is 16 g/mol, and the molecular mass for N_2H_4 is 32 g/mol. When we have the empirical formula and the molecular mass for a compound, we can divide the formula mass into the molecular mass and find the whole number that we need to multiply each of the subscripts in the empirical formula.

Example:

Find the molecular formula for a compound with percent composition of 40.0% carbon, 67.1% hydrogen, and 53.3% oxygen. The molecular mass of the compound is 180 g/mol.

Solution:

This is the same as an earlier example, except now we also have the molecular mass of the compound. Earlier, we determined the empirical formula of this compound to be CH_2O . The empirical formula has a formula mass of 30.0 g/mol. In order to find the molecular formula for this compound, we divide the formula mass into the molecular mass (180 divided by 30) and find the multiplier for the empirical formula to be 6. As a result, the molecular formula for this compound will be $\text{C}_6\text{H}_{12}\text{O}_6$.

Example:

Find the molecular formula for a compound with percent composition of 85.6% carbon and 14.5% hydrogen. The molecular mass of the compound is 42.1 g/mol.

Solution:

We choose a sample size of 100. g and multiply each element percentage to get masses for the elements in this sample. This yields 85.6 g of C and 14.5 g of H. Dividing each of these by their atomic mass yields 7.13 moles of C

and 14.4 moles of H. Dividing each of these by the smallest yields a whole number ratio of 1 carbon to 2 hydrogen. Thus, the empirical formula will be CH_2 .

The formula mass of CH_2 is 14 g/mol. Dividing 14 g/mol into the molecular mass of 42.1 g/mol yields a multiplier of 3. The molecular formula will be C_3H_6 .

Lesson Summary

- The empirical formula of a compound indicates the simplest whole number ratio of atoms present in the compound.
- The empirical formula of a compound can be calculate from the masses of the elements in the compound or from the percent composition.
- The molecular formula of a compound is some whole number multiple of the empirical formula.

Further Reading / Supplemental Links

This website has solved example problems for a number of topics covered in this lesson, including the determination of empirical and molecular formulas.

- <http://www.sciencejoywagon.com/chemzone/05chemical-reactions/>

Review Questions

1. What is the empirical formula for C_8H_{18} ?
2. What is the empirical formula for C_6H_6 ?
3. What is the empirical formula for WO_2 ?
4. A compound has the empirical formula $\text{C}_2\text{H}_8\text{N}$ and a molar mass of 46 g/mol. What is the molecular formula of this compound?
5. A compound has the empirical formula $\text{C}_2\text{H}_4\text{NO}$. If its molar mass is 116.1 g/mol, what is the molecular formula of the compound?
6. A sample of pure indium chloride with a mass of 0.5000 grams is found to contain 0.2404 grams of chlorine. What is the empirical formula of this compound?
7. Determine the empirical formula of a compound that contains 63.0 grams of rubidium and 5.90 grams of oxygen.
8. Determine the empirical formula of a compound that contains 58.0%Rb, 9.50%N, and 32.5%O.
9. Determine the empirical formula of a compound that contains 33.3%Ca, 40.0%O, and 26.7%S.
10. Find the molecular formula of a compound with percent composition 26.7%P, 12.1%N, and 61.2%Cl and with a molecular mass of 695 g/mol.

All images, unless otherwise stated, are created by the CK-12 Foundation and are under the Creative Commons license CC-BY-NC-SA.

CHAPTER

13

Chemical Reactions

Chapter Outline

13.1 CHEMICAL REACTIONS AND EQUATIONS

13.2 BALANCING CHEMICAL EQUATIONS

13.3 TYPES OF REACTIONS

13.1 Chemical Reactions and Equations

Lesson Objectives

The student will:

- explain what happens during a chemical reaction.
- identify the reactants and products in any chemical reaction.
- convert verbal descriptions of chemical reactions into chemical equations, and vice versa.
- use the common symbols (*s*), (*l*), (*g*), (*aq*), and \rightarrow appropriately.

Vocabulary

- chemical reaction
- products
- reactants

Introduction

In a chemical change, new substances are formed. In order for this to occur, the chemical bonds of the substances break, and the atoms that make up the substances separate and re-arrange themselves into new substances with new chemical bonds. When this process occurs, we call it a chemical reaction. A **chemical reaction** is the process in which one or more substances are changed into one or more new substances.

In order to describe a chemical reaction, we need to indicate what substances are present at the beginning and what substances are present at the end. The substances that are present at the beginning are called **reactants**, and the substances present at the end are called **products**.

Writing Chemical Equations

When sulfur dioxide is added to oxygen, sulfur trioxide is produced. In the chemical equation shown below, sulfur dioxide and oxygen (SO_2 and O_2) are reactants, and sulfur trioxide (SO_3) is the product.

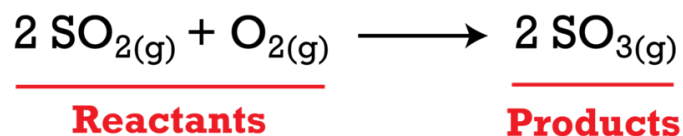

The general equation for a reaction is:

Reactants → Products

There are a few special symbols that we need to know in order to communicate in chemical shorthand. In **Table 13.1** is a summary of the major symbols used in chemical equations. There are other symbols, but these are the main ones that we need to know.

TABLE 13.1: Common Symbols in Chemical Reactions

Symbol	Meaning	Example
→	separates reactants from products; can be read as “to produce” or “to yield”	$2\text{H}_2 + \text{O}_2 \rightarrow 2\text{H}_2\text{O}$
+	separate reactants from each other or products from each other; can be read as “is added to”	$\text{AgNO}_3 + \text{NaCl} \rightarrow \text{AgCl} + \text{NaNO}_3$
(s)	in the solid state	sodium in the solid state = $\text{Na}_{(s)}$
(l) or (L)	in the liquid state	water in the liquid state = $\text{H}_2\text{O}_{(l)}$
(g)	in the gaseous state	carbon dioxide in the gaseous state = $\text{CO}_{2(g)}$
(aq)	in the aqueous state, dissolved in water	sodium chloride solution = $\text{NaCl}_{(aq)}$

Chemists have a choice of methods for describing a chemical reaction. They could draw a picture of the chemical reaction, like in the image shown below.

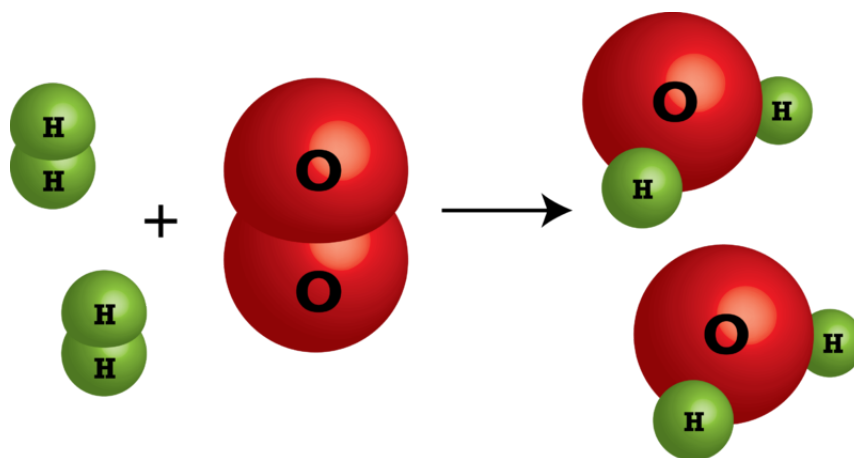

Alternatively, they could describe the reaction in words. The image above can be described as two molecules of hydrogen gas reacting with one molecule of oxygen gas to produce two molecules of water vapor.

Chemists could also write the equation in chemical shorthand.

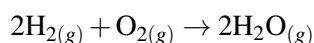

In the symbolic equation, chemical formulas are used instead of chemical names for reactants and products, and symbols are used to indicate the phase of each substance. It should be apparent that the chemical shorthand method is the quickest and clearest method for writing chemical equations. For example, we could write out that an aqueous solution of calcium nitrate is added to an aqueous solution of sodium hydroxide to produce solid calcium hydroxide and an aqueous solution of sodium nitrate. In shorthand, however, we could simply write:

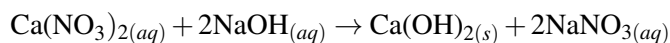

How much easier is that to read? Let's try it in reverse. Look at the following reaction in shorthand notation and describe the reaction in words.

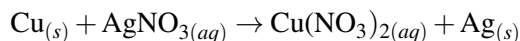

The description of this reaction might read something like "solid copper reacts with an aqueous solution of silver nitrate to produce a solution of copper(II) nitrate and solid silver."

Example:

Transfer the following symbolic equations into verbal descriptions or vice versa.

1. $\text{HCl}_{(aq)} + \text{NaOH}_{(aq)} \rightarrow \text{NaCl}_{(aq)} + \text{H}_2\text{O}_{(l)}$
2. Gaseous propane, C_3H_8 , burns in oxygen gas to produce gaseous carbon dioxide and liquid water.
3. Hydrogen fluoride gas reacts with an aqueous solution of potassium carbonate to produce an aqueous solution of potassium fluoride, liquid water, and gaseous carbon dioxide.

Solution:

1. An aqueous solution of hydrochloric acid reacts with an aqueous solution of sodium hydroxide to produce an aqueous solution of sodium chloride and liquid water.
2. $\text{C}_3\text{H}_{8(g)} + \text{O}_{2(g)} \rightarrow \text{CO}_{2(g)} + \text{H}_2\text{O}_{(l)}$
3. $\text{HF}_{(g)} + \text{K}_2\text{CO}_{3(aq)} \rightarrow \text{KF}_{(aq)} + \text{H}_2\text{O}_{(l)} + \text{CO}_{2(g)}$

Lesson Summary

- A chemical reaction is the process in which one or more substances are changed into one or more new substances.
- Chemical reactions are represented by chemical equations.
- Chemical equations have reactants on the left, an arrow that symbolizes "yields," and the products on the right.

Further Reading / Supplemental Links

This video shows ten amazing chemical reactions that are fun to watch but dangerous to carry out.

- <http://listverse.com/2008/03/04/top-10-amazing-chemical-reactions/>

Review Questions

1. Mothballs are commonly used to preserve clothing during off-season. We recognize mothballs by its smell because of a chemical compound known as naphthalene, C_{10}H_8 . What are the different elements found in naphthalene, and how many atoms of each are found in the formula?
2. Give the verbal description of the following chemical equations.
 - a. $\text{H}_2\text{SO}_{4(aq)} + \text{NaCN}_{(aq)} \rightarrow \text{HCN}_{(aq)} + \text{Na}_2\text{SO}_{4(aq)}$
 - b. $\text{Cu}_{(s)} + \text{AgNO}_{3(aq)} \rightarrow \text{Ag}_{(s)} + \text{Cu}(\text{NO}_3)_{2(aq)}$
 - c. $\text{Fe}_{(s)} + \text{O}_{2(g)} \rightarrow \text{Fe}_2\text{O}_{3(s)}$

3. Write the chemical equations for the following reactions.
 - a. Solid calcium metal is placed in liquid water to produce aqueous calcium hydroxide and hydrogen gas.
 - b. Aqueous sodium hydroxide is mixed with gaseous chlorine to produce aqueous solutions of sodium chloride and sodium hypochlorite plus liquid water.
 - c. Solid xenon hexafluoride is mixed with liquid water to produce solid xenon trioxide and gaseous hydrogen fluoride.

13.2 Balancing Chemical Equations

Lesson Objectives

The student will:

- explain the roles of subscripts and coefficients in chemical equations.
- write a balanced chemical equation when given the unbalanced equation for any chemical reaction.
- explain the role of the law of conservation of mass in a chemical reaction.

Vocabulary

- balanced chemical equation
- coefficient
- subscript

Introduction

Even though chemical compounds are broken up to form new compounds during a chemical reaction, atoms in the reactants do not disappear, nor do new atoms appear to form the products. In chemical reactions, atoms are never created or destroyed. The same atoms that were present in the reactants are present in the products. The atoms are merely re-organized into different arrangements. In a complete chemical equation, the two sides of the equation must be balanced. That is, in a **balanced chemical equation**, the same number of each atom must be present on the reactant and product sides of the equation.

Balancing Equations

The process of writing a balanced chemical equation involves three steps. As a beginning chemistry student, you will not know whether or not two given compounds will react or not. Even if you saw them react, you would not know what the products are without running any tests to identify them. Therefore, for the time being, you will be told both the reactants and products in any equation you are asked to balance.

Step 1: Know what the reactants and products are, and write a word equation for the reaction.

Step 2: Write the formulas for all the reactants and products.

Step 3: Adjust the coefficients to balance the equation.

There are a number of elements shown in **Table 13.2** that exist as diatomic molecules under normal conditions. When any of these elements appear in word equations, you must remember that the name refers to the diatomic molecule and insert the diatomic formula into the symbolic equation. If, under unusual circumstances, it was desired to refer

to the individual atoms of these elements, the text would refer specifically to atomic hydrogen, atomic oxygen, and so on.

TABLE 13.2: Homonuclear Diatomic Molecules

Element	Formula for Diatomic Molecule	Phase at Room Temperature
Hydrogen	H ₂	Gaseous
Oxygen	O ₂	Gaseous
Nitrogen	N ₂	Gaseous
Chlorine	Cl ₂	Gaseous
Fluorine	F ₂	Gaseous
Bromine	Br ₂	Liquid
Iodine	I ₂	Solid

There are two types of numbers that appear in chemical equations. There are **subscripts**, which are part of the chemical formulas of the reactants and products, and there are **coefficients** that are placed in front of the formulas to indicate how many molecules of that substance are used or produced. In the chemical formula shown below, the coefficients and subscripts are labeled.

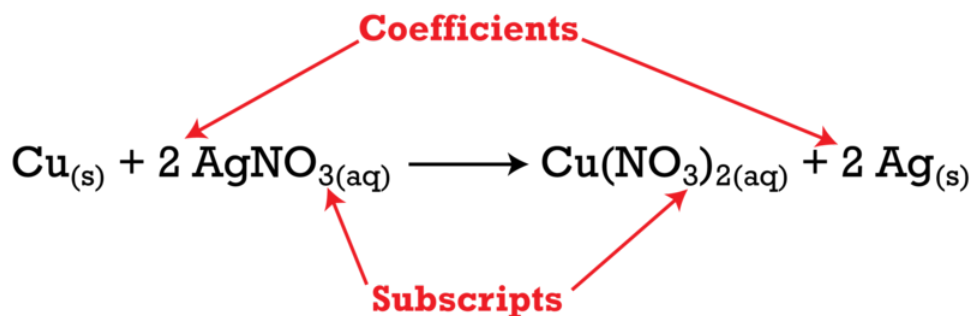

The equation above indicates that one mole of solid copper is reacting with two moles of aqueous silver nitrate to produce one mole of aqueous copper(II) nitrate and two moles of solid silver. Recall that a subscript of 1 is not written - when no subscript appears for an atom in a formula, it is understood that only one atom is present. The same is true in writing balanced chemical equations. If only one atom or molecule is present, the coefficient of 1 is omitted.

The subscripts are part of the formulas, and once the formulas for the reactants and products are determined, the subscripts may not be changed. The coefficients indicate the mole ratios of each substance involved in the reaction and may be changed in order to balance the equation. Coefficients are inserted into the chemical equation in order to make the total number of each atom on both sides of the equation equal. Note that equation balancing is accomplished by changing coefficients, *never* by changing subscripts.

Example:

Write a balanced equation for the reaction that occurs between chlorine gas and aqueous sodium bromide to produce liquid bromine and aqueous sodium chloride.

Step 1: Write the word equation (keeping in mind that chlorine and bromine refer to the diatomic molecules).

chlorine + sodium bromide yields bromine + sodium chloride

Step 2: Substitute the correct formulas into the equation.

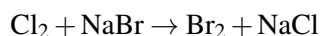

Step 3: Insert coefficients where necessary to balance the equation.

By placing a coefficient of 2 in front of NaBr, we can balance the bromine atoms. By placing a coefficient of 2 in front of the NaCl, we can balance the chlorine atoms.

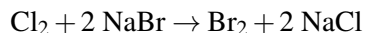

A final check (always do this) shows that we have the same number of each atom on the two sides of the equation. We have also used the smallest whole numbers possible as the coefficients, so this equation is properly balanced.

Example:

Write a balanced equation for the reaction between aluminum sulfate and calcium bromide to produce aluminum bromide and calcium sulfate. Recall that polyatomic ions usually remain together as a unit throughout a chemical reaction.

Step 1: Write the word equation.

aluminum sulfate + calcium bromide yields aluminum bromide + calcium sulfate

Step 2: Replace the names of the substances in the word equation with formulas.

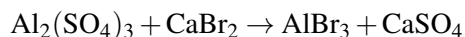

Step 3: Insert coefficients to balance the equation.

In order to balance the aluminum atoms, we must insert a coefficient of 2 in front of the aluminum compound in the products.

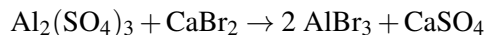

In order to balance the sulfate ions, we must insert a coefficient of 3 in front of the product CaSO₄.

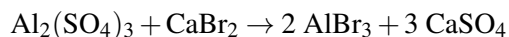

In order to balance the bromine atoms, we must insert a coefficient of 3 in front of the reactant CaBr₂.

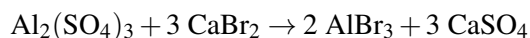

The insertion of the 3 in front of the reactant CaBr₂ also balances the calcium atoms in the product CaSO₄. A final check shows that there are two aluminum atoms, three sulfur atoms, twelve oxygen atoms, three calcium atoms, and six bromine atoms on each side. This equation is balanced.

Note that this equation would still have the same number of atoms of each type on each side with the following set of coefficients:

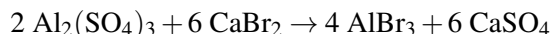

Count the number of each type of atom on either side of the equation to confirm that this equation is “balanced.” While this set of coefficients does “balanced” the equation, they are not the lowest set of coefficients possible. Chemical equations should be balanced with the simplest whole number coefficients. We could divide each of the coefficients in this equation by 2 to get another set of coefficients that still balance the equation and are whole numbers. Since it is required that an equation be balanced with the lowest whole number coefficients, the equation above is *not* properly balanced. When you have finished balancing an equation, you should not only check to make

sure it is balanced, you should also check to make sure that it is balanced with the simplest set of whole number coefficients possible.

Example:

Balance the following skeletal equation. (The term “skeletal equation” refers to an equation that has the correct chemical formulas but does not include the proper coefficients.)

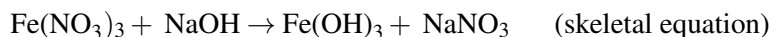
**Solution:**

We can balance the hydroxide ion by inserting a coefficient of 3 in front of the NaOH on the reactant side.

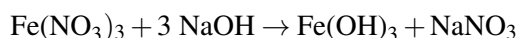

We can then balance the nitrate ions by inserting a coefficient of 3 in front of the sodium nitrate on the product side.

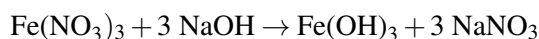

Counting the number of each type of atom on the two sides of the equation will now show that this equation is balanced.

Example:

Given the following skeletal (un-balanced) equations, balance them.

1. $\text{CaCO}_3(s) \rightarrow \text{CaO}(s) + \text{CO}_2(g)$
2. $\text{H}_2\text{SO}_4(aq) + \text{Al}(\text{OH})_3(aq) \rightarrow \text{Al}_2(\text{SO}_4)_3(aq) + \text{H}_2\text{O}(l)$
3. $\text{Ba}(\text{NO}_3)_2(aq) + \text{Na}_2\text{CO}_3(aq) \rightarrow \text{BaCO}_3(aq) + \text{NaNO}_3(aq)$
4. $\text{C}_2\text{H}_6(g) + \text{O}_2(g) \rightarrow \text{CO}_2(g) + \text{H}_2\text{O}(l)$

Solution:

1. $\text{CaCO}_3(s) \rightarrow \text{CaO}(s) + \text{CO}_2(g)$ (sometimes the skeletal equation is already balanced)
2. $3 \text{H}_2\text{SO}_4(aq) + 2 \text{Al}(\text{OH})_3(aq) \rightarrow \text{Al}_2(\text{SO}_4)_3(aq) + 6 \text{H}_2\text{O}(l)$
3. $\text{Ba}(\text{NO}_3)_2(aq) + \text{Na}_2\text{CO}_3(aq) \rightarrow \text{BaCO}_3(aq) + 2 \text{NaNO}_3(aq)$
4. $2 \text{C}_2\text{H}_6(g) + 7 \text{O}_2(g) \rightarrow 4 \text{CO}_2(g) + 6 \text{H}_2\text{O}(l)$

Conservation of Mass in Chemical Reactions

We already know from the law of conservation of mass that mass is conserved in chemical reactions. But what does this really mean? Consider the following reaction.

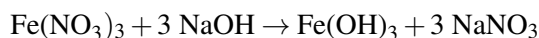

Verify to yourself that this equation is balanced by counting the number of each type of atom on each side of the equation. We can demonstrate that mass is conserved by determining the total mass on both sides of the equation.

Mass of the Reactant Side:

$$1 \text{ molecule of } \text{Fe}(\text{NO}_3)_3 \times \text{molecular weight} = (1) \cdot (241.9 \text{ daltons}) = 241.9 \text{ daltons}$$

3 molecules of NaOH \times molecular weight = (3) \cdot (40.0 daltons) = 120. daltons

Total mass of reactants = 241.9 daltons + 120. daltons = 361.9 daltons

Product Side Mass:

1 molecule of Fe(OH)₃ \times molecular weight = (1) \cdot (106.9 daltons) = 106.9 daltons

3 molecules of NaNO₃ \times molecular weight = (3) \cdot (85.0 daltons) = 255 daltons

Total mass of products = 106.9 daltons + 255 daltons = 361.9 daltons

As you can see, both the number of atoms and mass are conserved during chemical reactions. This is logically similar to saying that a group of 20 objects stacked in different ways will still have the same total mass no matter how you stack them.

Lesson Summary

- Chemical equations must always be balanced.
- Balanced chemical equations have the same number and type of each atom on both sides of the equation.
- The coefficients in a balanced equation must be the simplest whole number ratio.
- Mass is always conserved in chemical reactions.

Review Questions

1. Explain in your own words why coefficients can change but subscripts must remain constant.
2. Which set of coefficients will properly balance the following equation: $\text{C}_2\text{H}_6 + \text{O}_2 \rightarrow \text{CO}_2 + \text{H}_2\text{O}$?
 - a. 1, 1, 1, 1
 - b. 1, 3, 2, 2
 - c. 1, 3.5, 2, 3
 - d. 2, 7, 4, 6
3. When properly balanced, what is the sum of all the coefficients in the following chemical equation: $\text{SF}_4 + \text{H}_2\text{O} \rightarrow \text{H}_2\text{SO}_3 + \text{HF}$?
 - a. 4
 - b. 7
 - c. 9
 - d. None of the above
4. When the following equation is balanced, what is the coefficient found in front of the O₂: $\text{P}_4 + \text{O}_2 + \text{H}_2\text{O} \rightarrow \text{H}_3\text{PO}_4$?
 - a. 1
 - b. 3
 - c. 5
 - d. 7
5. Balance the following equations.
 - a. $\text{XeF}_6(s) + \text{H}_2\text{O}(l) \rightarrow \text{XeO}_3(s) + \text{HF}(g)$
 - b. $\text{Cu}(s) + \text{AgNO}_3(aq) \rightarrow \text{Ag}(s) + \text{Cu}(\text{NO}_3)_2(aq)$
 - c. $\text{Fe}(s) + \text{O}_2(g) \rightarrow \text{Fe}_2\text{O}_3(s)$
 - d. $\text{Al}(\text{OH})_3 + \text{Mg}_3(\text{PO}_4)_2 \rightarrow \text{AlPO}_4 + \text{Mg}(\text{OH})_2$

13.3 Types of Reactions

Lesson Objectives

The student will:

- describe what is occurring in synthesis, decomposition, single replacement, double replacement, and combustion reactions.
- classify a chemical reaction as a synthesis, decomposition, single replacement, double replacement, or a combustion reaction.
- predict the products of simple reactions.

Vocabulary

- combustion reaction
- decomposition reaction
- double replacement reaction
- hydrocarbon
- single replacement reaction
- synthesis reaction

Introduction

Chemical reactions are classified into types to help us analyze them and to help us predict what the products of the reaction will be. The five major types of chemical reactions are synthesis, decomposition, single replacement, double replacement, and combustion.

Synthesis Reactions

A **synthesis reaction** is one in which two or more reactants combine to make one product. The general equation for a synthesis reaction is:

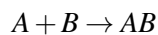

Synthesis reactions occur as a result of two or more simpler elements or molecules combining to form a more complex molecule. We can always identify a synthesis reaction because there is only one product. If you are given elemental reactants and told that the reaction is a synthesis reaction, you should be able to predict the products. For example, consider the equation below. Two elements (hydrogen and oxygen) combine to form one product (water).

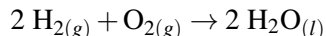

You should also be able to write the chemical equation for a synthesis reaction if you are given a product by picking out its elements and writing the equation. As a result, we can write the synthesis reaction for sodium chloride just by knowing the elements that are present in the product.

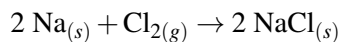
**Example:**

1. Write the chemical equation for the synthesis reaction of silver bromide, AgBr.
2. Predict the products for the following reaction: $\text{CO}_{2(g)} + \text{H}_2\text{O}_{(l)}$.
3. Predict the products for the following reaction: $\text{Li}_2\text{O}_{(s)} + \text{CO}_{2(g)}$.

Solution:

1. $2 \text{Ag}_{(s)} + \text{Br}_{2(l)} \rightarrow 2 \text{AgBr}_{(s)}$
2. $\text{CO}_{2(g)} + \text{H}_2\text{O}_{(l)} \rightarrow \text{H}_2\text{CO}_{3(aq)}$
3. $\text{Li}_2\text{O}_{(s)} + \text{CO}_{2(g)} \rightarrow \text{Li}_2\text{CO}_{3(s)}$

Decomposition Reactions

When one type of reactant breaks down to form two or more products, we have a **decomposition reaction**. The best way to remember a decomposition reaction is that for all reactions of this type, there is only one reactant. The general equation for a decomposition reaction is:

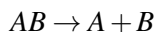

Look at the equation below for an example of a decomposition reaction. In this reaction, ammonium nitrate breaks down to form dinitrogen oxide and water.

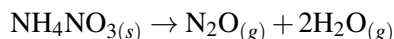

Notice that there is only one reactant, NH_4NO_3 , on the left of the arrow and that there is more than one on the right side of the arrow. This is the exact opposite of a synthesis reaction.

When studying decomposition reactions, we can predict the reactants in a similar manner as we did for synthesis reactions. Look at the formula for magnesium nitride, Mg_3N_2 . What elements do you see in this formula? You see magnesium and nitrogen. Now we can write a decomposition reaction for magnesium nitride.

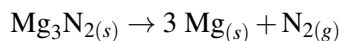

Notice there is only one reactant.

Example:

Write the chemical equation for the decomposition of the following compounds into their individual elements:

1. Al_2O_3
2. Ag_2S
3. MgO

Solution:

1. $2 \text{Al}_2\text{O}_3 \rightarrow 4 \text{Al} + 3 \text{O}_2$
2. $\text{Ag}_2\text{S} \rightarrow 2 \text{Ag} + \text{S}$
3. $2 \text{MgO} \rightarrow 2 \text{Mg} + \text{O}_2$

Single Replacement Reactions

A third type of reaction is the single replacement reaction. In **single replacement reactions**, one element reacts with one compound to form products. The single element is said to replace an element in the compound when the products form, hence the name single replacement.

There are actually three different types of single replacement reactions: 1) the single element is a metal and replaces the metal in the second reactant, 2) the single element is a metal and replaces the hydrogen in the second reactant, which is always an acid, and 3) the single element is a nonmetal and replaces the nonmetal in the second reactant.

Replacement of a Metal with a Metal

In this section, we will focus on single replacement reactions where an elemental metal reactant replaces the metal (or the cation) of a second compound. The general equation for this reaction is:

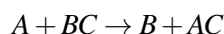

Consider the following example. Notice there is only one reactant that is an element and one reactant that is a compound.

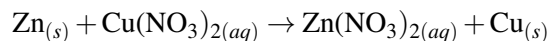

When studying single replacement reactions, we can predict reactants in a similar manner as we did for synthesis and decomposition reactions. Suppose that we know a single replacement reaction will occur between solid aluminum and solid iron(III) oxide.

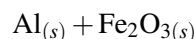

In order to predict the products, we need to know that aluminum will replace iron and form aluminum oxide. Aluminum has a charge of +3 (it is in Group 3A), and oxygen has a charge of -2 (it is in Group 6A). The compound formed between aluminum and oxygen, therefore, will be $\text{Al}_2\text{O}_{3(s)}$. Since iron is replaced in the compound by aluminum, the iron product will now be a single element. The unbalanced equation will be:

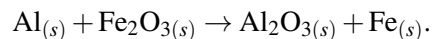

The balanced equation will be:

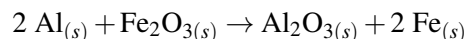
**Example:**

1. Write the chemical equation for the single replacement reaction between zinc solid and lead(II) nitrate solution to produce zinc nitrate solution and solid lead.

- Predict the products for the following reaction: $\text{Fe} + \text{CuSO}_4$.
- Predict the products for the following reaction: $\text{Al} + \text{CuCl}_2$.

Solution:

- $\text{Zn}_{(s)} + \text{Pb}(\text{NO}_3)_{2(aq)} \rightarrow \text{Pb}_{(s)} + \text{Zn}(\text{NO}_3)_{2(aq)}$
- $\text{Fe}_{(s)} + \text{CuSO}_{4(aq)} \rightarrow \text{Cu}_{(s)} + \text{FeSO}_{4(aq)}$
- $2 \text{Al} + 3 \text{CuCl}_2 \rightarrow 3 \text{Cu} + 2 \text{AlCl}_3$

Replacement of Hydrogen with a Metal

These reactions are the same as those studied in the last section, except the compound in the reactant side of the equation is always an acid. Since you may not have studied acids yet, you should consider an acid to be a compound in which hydrogen is combined with an anion. Therefore, in this section, we will consider single replacement reactions where the element reactant replaces the hydrogen in the acid compound. The general reaction is:

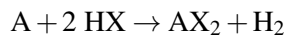

The chemical equation below is an example of this type of reaction:

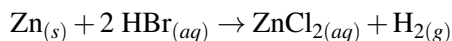

When studying these single replacement reactions, we can predict reactants in a similar manner as we did for the other types of single replacement reactions. Look at the reaction below. Since HCl is a compound that has hydrogen combined with an anion, it is an acid.

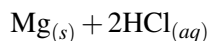

In order to predict the products, we need to know that magnesium will replace hydrogen and form magnesium chloride. Magnesium has a charge of +2 (it is in Group 2A), and chlorine has a charge of -1 (it is in group 7A). Therefore, the compound formed will be MgCl_2 . The replaced hydrogen forms the product elemental hydrogen, H_2 . After the products are determined, all that remains is to balance the equation.

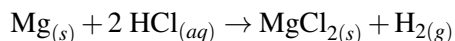

Notice that one reactant is the element Mg and one reactant is an acid compound. The Mg has replaced the hydrogen in HCl in the same manner as Zn replaced the hydrogen in the HBr in the example above.

Example:

- Write the chemical equation for the single replacement reaction between iron solid and hydrochloric acid solution to produce iron(II) chloride solution and hydrogen gas.
- Predict the products for the following reaction: $\text{Zn}_{(s)} + \text{H}_2\text{SO}_{4(aq)}$.
- Predict the products for the following reaction: $\text{Al}_{(s)} + \text{HNO}_{3(aq)}$.

Solution:

- $\text{Fe}_{(s)} + 2 \text{HCl}_{(aq)} \rightarrow \text{FeCl}_{2(aq)} + \text{H}_{2(g)}$
- $\text{Zn}_{(s)} + \text{H}_2\text{SO}_{4(aq)} \rightarrow \text{ZnSO}_{4(aq)} + \text{H}_{2(g)}$
- $2 \text{Al}_{(s)} + 6 \text{HNO}_{3(aq)} \rightarrow 2 \text{Al}(\text{NO}_3)_{3(aq)} + 3 \text{H}_{2(g)}$

Replacement of a Nonmetal with a Nonmetal

In this section, we will focus on the final type of single replacement reactions where the element reactant replaces the nonmetal (or the anion) in a compound. The general equation for this type of reaction is:

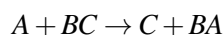

Notice in the equation below that the chlorine replaced the iodine to produce solid iodine as a product. We can predict the products for these single replacement reactions in a similar manner as for all other single replacement reactions. The only difference here is that we have to remember that we are replacing the anion of the compound rather than the cation.

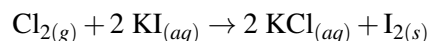

Look at the reaction between chlorine gas and sodium bromide shown below. This is an actual method for extracting bromine from ocean water found to contain sodium bromide. Can you complete the reaction?



In order to predict the products of this reaction, we need to know that chlorine will replace bromine and form sodium chloride. Sodium has a charge of +1 (it is in Group 1A) and chlorine has a charge of -1 (it is in group 7A). The compound formed will be NaCl.

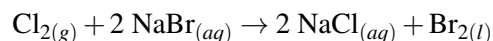

Notice, as with all of the other single replacement reactions, that the reactants include one element and one compound, and the products contain one element and one compound. This is the determining factor for identifying whether you have a single replacement reaction.

Example:

1. Write the chemical equation for the single replacement reaction between sodium iodide solution and liquid bromine to produce sodium bromide solution and solid iodine.
2. Predict the products for the following reaction: $\text{Br}_{2(aq)} + \text{KI}_{(aq)}$.
3. Predict the products for the following reaction: $\text{MgI}_{2(aq)} + \text{Cl}_{2(aq)}$.

Solution:

1. $2 \text{NaI}_{(aq)} + \text{Br}_{2(l)} \rightarrow 2 \text{NaBr}_{(aq)} + \text{I}_{2(s)}$
2. $\text{Br}_{2(aq)} + 2 \text{KI}_{(aq)} \rightarrow 2 \text{KBr}_{(aq)} + \text{I}_{2(s)}$
3. $\text{MgI}_{2(aq)} + \text{Cl}_{2(aq)} \rightarrow \text{MgCl}_{2(aq)} + \text{I}_{2(s)}$

Double Replacement

For **double replacement reactions**, two reactants will react by having the cations exchange places. The key to identifying this type of reaction is to recognize that it has two compounds as reactants. This type of reaction is more common than any of the others, and there are many different types of double replacement reactions. Some double replacement reactions are more common than others. For example, precipitation and neutralization reactions are two of the most common double replacement reactions. Precipitation reactions are ones where two aqueous reactants

combine to form products where one of the products is an insoluble solid. A neutralization reaction is one where the two reactant compounds are an acid and a base and the two products are a salt and water.

Example:

The following is a precipitation reaction because $\text{AgCl}_{(s)}$ is formed.

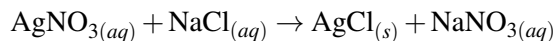

The following is a neutralization reaction because the acid, H_2SO_4 , is neutralized by the base, NaOH .

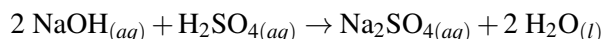

In order to write the products for a double displacement reaction, you must be able to determine the correct formulas for the new compounds. Consider this common laboratory experiment that involves the reaction between lead(II) nitrate and sodium iodide, both clear solutions. Here is the start of the reaction:

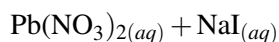

Now, predict the products based on what you know about charges. We know that the cations exchange anions. We now have to look at the charges of each of the cations and anions to see what the products will be.

We should presume the charge of the lead will remain +2, and since iodine forms ions with a charge of -1 , one product will be PbI_2 . The other product will form between the sodium ion, whose charge is +1, and the nitrate ion, whose charge is -1 . Therefore, the second product will be NaNO_3 . Once the products are written in, the equation can be balanced.

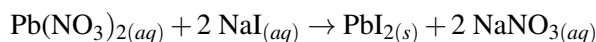

The experiment produces a brilliant yellow precipitate. If you have use of a solubility table, it is easy to determine that the precipitate will be the lead(II) iodide. Even without a solubility table, knowing that lead compounds tend to precipitate and sodium compounds are always soluble, we would still be able to determine that the PbI_2 is the brilliant yellow precipitate.

Look at the reaction between acetic acid and barium hydroxide below.



Try to predict the products by having the cations exchange places and writing the correct formulas for the products formed.

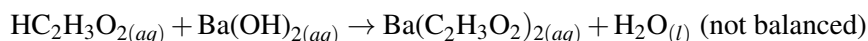

Therefore, the final balanced equation will be:

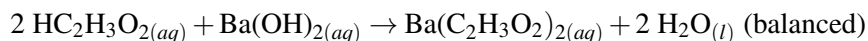

This is an acid-base reaction yielding salt, barium acetate, and water. Notice that HOH and H_2O are the same.

Example:

1. Write a chemical equation for the double replacement reaction between calcium chloride solution and potassium hydroxide solution that produces potassium chloride solution and a precipitate of calcium hydroxide.
2. Predict the products for the following reaction: $\text{AgNO}_{3(aq)} + \text{NaCl}_{(aq)}$.

3. Predict the products for the following reaction: $\text{FeCl}_3(aq) + \text{KOH}(aq)$.

Solution:

- $\text{CaCl}_2(aq) + 2 \text{KOH}(aq) \rightarrow \text{Ca(OH)}_2(s) + 2 \text{KCl}(aq)$
- $\text{AgNO}_3(aq) + \text{NaCl}(aq) \rightarrow \text{AgCl}(s) + \text{NaNO}_3(aq)$
- $\text{FeCl}_3(aq) + 3 \text{KOH}(aq) \rightarrow \text{Fe(OH)}_3(s) + 3 \text{KCl}(aq)$

Combustion

A special type of single replacement reaction deserves some attention. These reactions are **combustion reactions**. In a combustion reaction, oxygen reacts with another substance to produce carbon dioxide and water.

In a particular branch of chemistry, known as organic chemistry, we study compounds known as hydrocarbons. A **hydrocarbon** is an organic substance consisting of only hydrogen and carbon. Combustion reactions usually have a hydrocarbon reacting with oxygen to produce CO_2 and H_2O . In other words, the only part that changes from one combustion reaction to the next is the actual hydrocarbon involved in the reaction. The general equation for this reaction is given below. Notice oxygen, carbon dioxide, and water are listed in the general equation to show that these reactants and products remain the same from combustion reaction to combustion reaction.

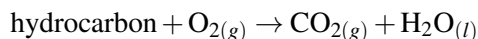

Look at the the combustion reaction of octane, C_8H_{18} , shown below. Octane has 8 carbon atoms, hence the prefix “oct-.”

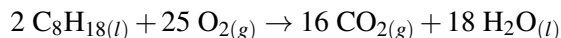

This reaction is referred to as complete combustion. Complete combustion reactions occur when there is enough oxygen to burn the entire hydrocarbon. This is why the only products are carbon dioxide and water.

Have you ever been in a lab and seen black soot appear on the bottom of a heated beaker? Or, have you ever seen the black puffs of smoke come out from the exhaust pipe of a car? If there is not enough oxygen, the result is an incomplete combustion reaction with $\text{CO}(g)$ and $\text{C}(s)$ (in the form of soot) also formed as products. Incomplete combustion reactions are actually quite dangerous because one of the products in the reaction is carbon monoxide, not carbon dioxide. Carbon monoxide is a gas that prevents oxygen from binding to the oxygen transport proteins in our blood cells. When the concentration of carbon monoxide in the blood becomes too high, not enough oxygen can be transported and the person can die.

Example:

Identify whether each of the following reactions are complete or incomplete combustions, and then balance the equation.

- $\text{C}_7\text{H}_{16}(l) + \text{O}_2(g) \rightarrow \text{CO}_2(g) + \text{H}_2\text{O}(l)$
- $\text{C}_3\text{H}_8(g) + \text{O}_2(g) \rightarrow \text{CO}_2(g) + \text{H}_2\text{O}(l)$
- $\text{CH}_4(g) + \text{O}_2(g) \rightarrow \text{CO}(g) + \text{H}_2\text{O}(l)$
- $\text{C}_5\text{H}_{12}(l) + \text{O}_2(g) \rightarrow \text{CO}_2(g) + \text{H}_2\text{O}(l)$
- $\text{C}_2\text{H}_6(g) + \text{O}_2(g) \rightarrow \text{CO}(g) + \text{H}_2\text{O}(l)$

Solution:

- Complete; $\text{C}_7\text{H}_{16}(l) + 11 \text{O}_2(g) \rightarrow 7 \text{CO}_2(g) + 8 \text{H}_2\text{O}(l)$

2. Complete; $\text{C}_3\text{H}_8(g) + 5 \text{O}_2(g) \rightarrow 3 \text{CO}_2(g) + 4 \text{H}_2\text{O}(l)$
3. Incomplete; $2 \text{CH}_4(g) + 3 \text{O}_2(g) \rightarrow 2 \text{CO}(g) + 4 \text{H}_2\text{O}(l)$
4. Complete; $\text{C}_5\text{H}_{12}(l) + 8 \text{O}_2(g) \rightarrow 5 \text{CO}_2(g) + 6 \text{H}_2\text{O}(l)$
5. Incomplete; $2 \text{C}_2\text{H}_6(g) + 5 \text{O}_2(g) \rightarrow 4 \text{CO}(g) + 6 \text{H}_2\text{O}(l)$

This video contains classroom demonstrations of several reaction types and then shows the balancing process for the reaction equations (3a) <http://www.youtube.com/watch?v=4B8PFqbMNIw> (8:40).



MEDIA

Click image to the left for more content.

Lesson Summary

TABLE 13.3: The Five Types of Chemical Reactions

Reaction Name	Reaction Description
synthesis	two or more reactants form one product.
decomposition	one type of reactant forms two or more products.
single replacement	one element reacts with one compound to form products.
double replacement	two compounds act as reactants.
combustion	a hydrocarbon reacts with oxygen gas.

Further Reading / Supplemental Links

The website below also reviews the different types of chemical reactions.

- <http://library.thinkquest.org/2923/react.html>

Review Questions

1. When balancing combustion reactions, did you notice a consistency relating to whether the number of carbons in the hydrocarbon was odd or even?
2. Distinguish between synthesis and decomposition reactions.
3. When dodecane, $\text{C}_{10}\text{H}_{22}$, burns in excess oxygen, the products would be:
 - a. $\text{CO}_2 + 2 \text{H}_2$
 - b. $\text{CO} + \text{H}_2\text{O}$
 - c. $\text{CO}_2 + \text{H}_2\text{O}$
 - d. CH_4O_2

4. In the decomposition of antimony trichloride, which of the following products and quantities will be found?
 - a. $\text{An} + \text{Cl}_2$
 - b. $2 \text{An} + 3 \text{Cl}_2$
 - c. $\text{Sb} + \text{Cl}_2$
 - d. $2 \text{Sb} + 3 \text{Cl}_2$
5. Acetylsalicylic acid (aspirin), $\text{C}_9\text{H}_8\text{O}_4(s)$, is produced by reacting acetic anhydride, $\text{C}_4\text{H}_6\text{O}_3(l)$, with salicylic acid, $\text{C}_7\text{H}_6\text{O}_3(s)$. The other product in the reaction is acetic acid, $\text{C}_2\text{H}_4\text{O}_2(l)$. Write the balanced chemical equation.
6. When iron rods are placed in liquid water, a reaction occurs. Hydrogen gas evolves from the container, and iron(III) oxide forms onto the iron rod.
 - a. Write a balanced chemical equation for the reaction.
 - b. What type of reaction is this?
7. A specific fertilizer is being made at an industrial plant nearby. The fertilizer is called a triple superphosphate and has a formula $\text{Ca}(\text{H}_2\text{PO}_4)_2$. It is made by treating sand and clay that contains phosphate with a calcium phosphate solution and phosphoric acid. The simplified reaction is calcium phosphate reacting with phosphoric acid to yield the superphosphate. Write the balanced chemical equation and name the type of reaction.

All images, unless otherwise stated, are created by the CK-12 Foundation and are under the Creative Commons license CC-BY-NC-SA.

CHAPTER 14**Stoichiometry****Chapter Outline**

- 14.1 INTRODUCTION TO STOICHIOMETRY**
 - 14.2 STOICHIOMETRIC CALCULATIONS**
 - 14.3 LIMITING REACTANT**
 - 14.4 PERCENT YIELD**
-

14.1 Introduction to Stoichiometry

Lesson Objectives

The student will:

- explain the meaning of the term “stoichiometry.”
- interpret chemical equations in terms of molecules, formula units, and moles.

Vocabulary

- formula unit
- stoichiometry

Introduction

You have learned that chemical equations provide us with information about the types of particles that react to form products. Chemical equations also provide us with the relative number of particles and moles that react to form products. In this chapter, you will explore the quantitative relationships that exist between the reactants and products in a balanced equation. This is known as stoichiometry.

Stoichiometry involved calculating the quantities of reactants or products in a chemical reaction using the relationships found in the balanced chemical equation. The word stoichiometry actually comes from two Greek words: *stoikheion*, which means element, and *metron*, which means measure.

Molecules and Formula Units

Before proceeding, recall the differences between molecules and formula units. A formula unit is used specifically with ionic compounds and refers to the smallest unit in the ionic compound. For example, the formula for potassium chloride, KCl. One formula unit of potassium chloride contains one ion of potassium and one chloride ion. Recall from the chapter “Ionic Bonds and Formulas” that ionic compounds are made up of positive and negative ions held together by electrostatic attraction. When we write KCl, we are only writing the ratio of K^+ ions to Cl^- ions involved in a crystal of potassium chloride, not an actual unit that exists by itself.



Another example of an ionic compound is copper(II) chloride, $CuCl_2$. A formula unit of copper(II) chloride is composed of one ion of copper and two chloride ions. Again, one unit of $CuCl_2$ does not exist by itself. Instead, $CuCl_2$ is a crystalline structure that has a ratio of one copper ion to two chloride ions.



In other words, ionic compounds are not composed of molecules. Therefore, we use the term formula unit to represent one unit of an ionic compound.

Covalent compounds are discrete molecules where the atoms join together by sharing electrons. For example, one molecule of carbon tetrachloride, CCl_4 , contains one carbon and four chlorine atoms, not ions, joined together by sharing of electrons. In the figure below, a space-filling model for CCl_4 is shown on the left, and the Lewis structure is shown on the right.

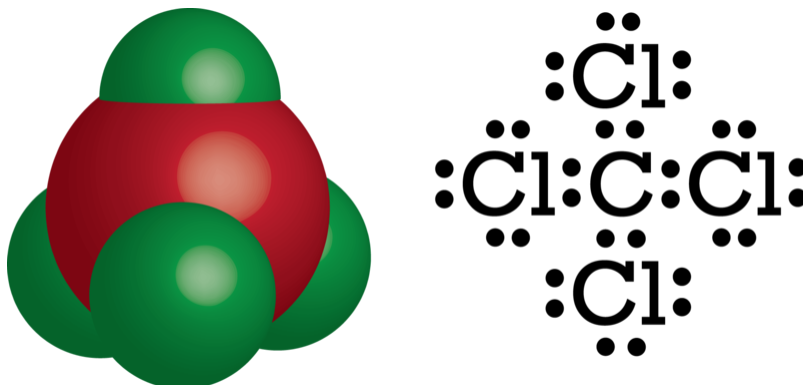

We can call this a molecule since there is a singular unit consisting of one carbon atom and four chlorine atoms that can act independently from other units or molecules of CCl_4 . Water, H_2O , is another example of a covalently bonded compound that exists as discrete molecules.

Interpreting Chemical Equations

Recall from the chapter “The Mole Concept” that a mole is a quantitative measure equivalent to Avogadro’s number of particles. How does the mole relate to the chemical equation? Consider the following reaction:

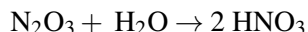

We have learned that the coefficients in a chemical equation tell us the relative amounts of each substance involved in the reaction. One way to describe the ratios involved in the reaction above would be, “One *molecule* of dinitrogen trioxide, N_2O_3 , plus one *molecule* of water yields two *molecules* of nitrous acid, HNO_3 .” However, because these are only ratios, this statement would be equally valid using units other than molecules. As a result, we could also say, “One *mole* of dinitrogen trioxide plus one *mole* of water yields two *moles* of nitrous acid.”

We can use moles instead of molecules, because a mole is simply an amount equal to Avogadro’s number, just like a dozen is an amount equal to 12. It is important to not use units that describe properties other than amount. For example, it would *not* be correct to say that one gram of dinitrogen trioxide plus one gram of water yields two grams of nitrous acid.

Now consider this reaction:

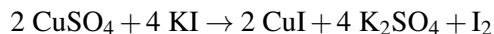

Here, we can say, “Two moles of copper(II) sulfate react with four moles of potassium iodide, yielding two moles of copper(I) iodide, four moles of potassium sulfate, and one mole of molecular iodine.” Although we can refer to

molecules of iodine, I_2 , it is generally not correct to refer to molecules of something like KI. Because KI is an ionic substance that exists as crystal lattices instead of discrete molecules, formula unit is used instead.

Example:

Indicate the ratio of compounds involved in the following balanced chemical equations. Describe the ratios in two ways: a) using the number of formula units or molecules and b) using the number of moles present.

- $2 C_2H_6 + 7 O_2 \rightarrow 4 CO_2 + 6 H_2O$
- $KBrO_3 + 6 KI + 6 HBr \rightarrow 7 KBr + 3 I_2 + 3 H_2O$

Solution:

- Two molecules of C_2H_6 plus seven molecules of O_2 yields four molecules of CO_2 plus six molecules of H_2O .
 - Two moles of C_2H_6 plus seven moles of O_2 yields four moles of CO_2 plus six moles of H_2O .
-
- One formula unit of $KBrO_3$ plus six formula units of KI plus six molecules of HBr yields seven formula units of KBr plus three molecules of I_2 and three molecules of H_2O .
 - One mole of $KBrO_3$ plus six moles of KI plus six moles of HBr yields seven moles of KBr plus three moles of I_2 and three moles of H_2O .

Lesson Summary

- Stoichiometry is the calculation of the quantities of reactants or products in a chemical reaction using the relationships found in the balanced chemical equation.

Further Reading / Supplemental Links

This website contains various resources, including PowerPoint lectures, on many topics in chemistry, including one on stoichiometry.

- <http://www.chalkbored.com/lessons/chemistry-11.htm>

Review Questions

- Distinguish between formula unit, molecule, and mole. Give examples in your answer.

14.2 Stoichiometric Calculations

Lesson Objectives

The student will:

- explain the importance of balancing equations before determining mole ratios.
- determine mole ratios in chemical equations.
- calculate the number of moles of any reactant or product from a balanced equation given the number of moles of one reactant or product.
- calculate the mass of any reactant or product from a balanced equation given the mass of one reactant or product.

Vocabulary

- mole ratio

Introduction

Earlier, we explored mole relationships in balanced chemical equations. In this lesson, we will use the mole as a conversion factor to calculate moles of product from a given number of moles of reactant, or we can calculate the number of moles of reactant from a given number of moles of product. This is called a “mole-mole” calculation. We will also perform “mass-mass” calculations, which allow you to determine the mass of reactant required to produce a given amount of product, or the mass of product you can obtain from a given mass of reactant.

Mole Ratios

A **mole ratio** is the relationship between two components of a chemical reaction. For instance, one way we could read the following reaction is that 2 moles of $\text{H}_{2(g)}$ react with 1 mole of $\text{O}_{2(g)}$ to produce 2 moles of $\text{H}_2\text{O}_{(l)}$.

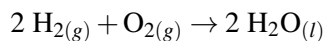

The mole ratio of $\text{H}_{2(g)}$ to $\text{O}_{2(g)}$ would be:

$$\frac{2 \text{ mol H}_2}{1 \text{ mol O}_2} \quad \text{or} \quad \frac{1 \text{ mol O}_2}{2 \text{ mol H}_2}$$

What is the ratio of hydrogen molecules to water molecules? By examining the balanced chemical equation, we can see that the coefficient in front of the hydrogen is 2, while the coefficient in front of water is also 2. Therefore, the mole ratio can be written as:

$$\frac{2 \text{ mol H}_2}{2 \text{ mol H}_2\text{O}} \quad \text{or} \quad \frac{2 \text{ mol H}_2\text{O}}{2 \text{ mol H}_2}$$

Similarly, the ratio of oxygen molecules to water molecules would be:

$$\frac{2 \text{ mol H}_2\text{O}}{1 \text{ mol O}_2} \quad \text{or} \quad \frac{1 \text{ mol O}_2}{2 \text{ mol H}_2\text{O}}$$

In the following example, let's try finding the mole ratios by first writing a balanced chemical equation from a "chemical sentence."

Example:

Four moles of solid aluminum are mixed with three moles of gaseous oxygen to produce two moles of solid aluminum oxide. What is the mole ratio of (1) aluminum to oxygen, (2) aluminum to aluminum oxide, and (3) oxygen to aluminum oxide?

Solution:

Balanced chemical equation: $4 \text{ Al}_{(s)} + 3 \text{ O}_{2(g)} \rightarrow 2 \text{ Al}_2\text{O}_{3(s)}$

1. mole ratio of aluminum to oxygen = $\frac{4 \text{ mol Al}}{3 \text{ mol O}_2}$ or $\frac{3 \text{ mol O}_2}{4 \text{ mol Al}}$
2. mole ratio of aluminum to aluminum oxide = $\frac{4 \text{ mol Al}}{2 \text{ mol Al}_2\text{O}_3}$ or $\frac{2 \text{ mol Al}_2\text{O}_3}{4 \text{ mol Al}}$
3. mole ratio of oxygen to aluminum oxide = $\frac{3 \text{ mol O}_2}{2 \text{ mol Al}_2\text{O}_3}$ or $\frac{2 \text{ mol Al}_2\text{O}_3}{3 \text{ mol O}_2}$

Example:

Write the balanced chemical equation for the reaction of solid calcium carbide (CaC_2) with water to form aqueous calcium hydroxide and acetylene (C_2H_2) gas. When written, find the mole ratios for (1) calcium carbide to water and (2) calcium carbide to calcium hydroxide.

Solution:

Balanced chemical equation: $\text{CaC}_{2(s)} + 2 \text{ H}_2\text{O}_{(l)} \rightarrow \text{Ca(OH)}_{2(aq)} + \text{C}_2\text{H}_{2(g)}$

1. mole ratio of calcium carbide to water = $\frac{1 \text{ mol CaC}_2}{2 \text{ mol H}_2\text{O}}$ or $\frac{2 \text{ mol H}_2\text{O}}{1 \text{ mol CaC}_2}$
2. mole ratio of calcium carbide to calcium hydroxide = $\frac{1 \text{ mol CaC}_2}{1 \text{ mol Ca(OH)}_2}$

The correct mole ratios of the reactants and products in a chemical equation are determined by the balanced equation. Therefore, the chemical equation must always be balanced before the mole ratios are used for calculations. Looking at the unbalanced equation for the reaction of phosphorus trihydride with oxygen, it is difficult to guess the correct mole ratio of phosphorus trihydride to oxygen gas.

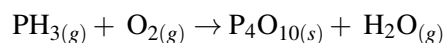

Once the equation is balanced, however, the mole ratio of phosphorus trihydride to oxygen gas is apparent.

Balanced chemical equation: $4 \text{ PH}_{3(g)} + 8 \text{ O}_{2(g)} \rightarrow \text{P}_4\text{O}_{10(s)} + 6 \text{ H}_2\text{O}_{(g)}$

The mole ratio of phosphorus trihydride to oxygen gas, then, is: $\frac{4 \text{ mol PH}_3}{8 \text{ mol O}_2}$

Keep in mind that before any mathematical calculations are made relating to a chemical equation, the equation *must* be balanced.

Mole-Mole Calculations

In the chemistry lab, we rarely work with exactly one mole of a chemical. In order to determine the amount of reagent (reacting chemical) necessary or the amount of product expected for a given reaction, we need to do calculations using mole ratios.

Look at the following equation. If only 0.50 moles of magnesium hydroxide, $\text{Mg}(\text{OH})_2$, are present, how many moles of phosphoric acid, H_3PO_4 , would be required for the reaction?

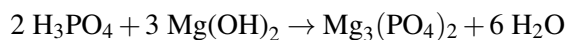

Step 1: To determine the conversion factor, we want to convert from moles of $\text{Mg}(\text{OH})_2$ to moles of H_3PO_4 . Therefore, the conversion factor is:

$$\text{mole ratio} = \frac{2 \text{ mol H}_3\text{PO}_4}{3 \text{ mol Mg}(\text{OH})_2}$$

Note that what we are trying to calculate is in the numerator, while what we know is in the denominator.

Step 2: Use the conversion factor to answer the question.

$$(0.50 \text{ mol Mg}(\text{OH})_2) \cdot \left(\frac{2 \text{ mol H}_3\text{PO}_4}{3 \text{ mol Mg}(\text{OH})_2} \right) = 0.33 \text{ mol H}_3\text{PO}_4$$

Therefore, if we have 0.50 mol of $\text{Mg}(\text{OH})_2$, we would need 0.33 mol of H_3PO_4 to react with all of the magnesium hydroxide. Notice if the equation was not balanced, the amount of H_3PO_4 required would have been calculated incorrectly. The ratio would have been 1:1, and we would have concluded that 0.5 mol of H_3PO_4 were required.

Example:

How many moles of sodium oxide (Na_2O) can be formed from 2.36 mol of sodium nitrate (NaNO_3) using the balanced chemical equation below?

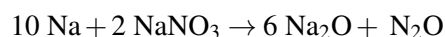

Solution:

$$(2.36 \text{ mol NaNO}_3) \cdot \left(\frac{6 \text{ mol Na}_2\text{O}}{2 \text{ mol NaNO}_3} \right) = 7.08 \text{ mol Na}_2\text{O}$$

Example:

How many moles of sulfur are required to produce 5.42 mol of carbon disulfide, CS_2 , using the balanced chemical equation below?

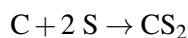

Solution:

$$(5.42 \text{ mol CS}_2) \cdot \left(\frac{2 \text{ mol S}}{1 \text{ mol CS}_2} \right) = 10.84 \text{ mol S}$$

Mass-Mass Calculations

A mass-mass calculation would allow you to solve one of the following types of problems:

- Determine the mass of reactant necessary to produce a given amount of product
- Determine the mass of product that would be produced from a given amount of reactant
- Determine the mass of reactant necessary to react completely with a second reactant

As was the case for mole ratios, it is important to double check that you are using a *balanced* chemical equation before attempting any calculations.

Using Proportion to Solve Stoichiometry Problems

All methods for solving stoichiometry problems contain the same four steps.

Step 1: Write and balance the chemical equation.

Step 2: Convert the given quantity to moles.

Step 3: Convert the moles of known to moles of unknown.

Step 4: Convert the moles of unknown to the requested units.

Step 1 has been covered in previous sections. We also just saw how to complete Step 3 in the previous section by using mole ratios. In order to complete the remaining two steps, we simply need to know how to convert between moles and the given or requested units.

In this section, we will be solving “mass-mass problems,” which means that both the given value and the requested answer will both be in units of mass, usually grams. Note that if some other unit of mass is used, you should convert to grams first, and use that value for further calculations. The conversion factor between grams and moles is the molar mass (g/mol). To find the number of moles in x grams of a substance, we divide by the molar mass, and to go back from moles to grams, we multiply by the molar mass. This process is best illustrated through examples, so let’s look at some sample problems.

The balanced equation below shows the reaction between hydrogen gas and oxygen gas to produce water. Since the equation is already balanced, Step 1 is already completed. Remember that the coefficients in the balanced equation are true for moles or molecules, but not for grams.

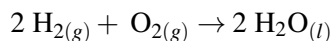

The molar ratio in this equation is two moles of hydrogen react with one mole of oxygen to produce two moles of water. If you were told that you were going to use 2.00 moles of hydrogen in this reaction, you would also know the moles of oxygen required for the reaction and the moles of water that would be produced. It is only slightly more difficult to determine the moles of oxygen required and the moles of water produced if you were told that you will be using 0.50 mole of hydrogen. Since you are using a quarter as much hydrogen, you would need a quarter as much oxygen and produce a quarter as much water. This is because the molar ratios keep the same proportion. If you were to write out a mathematical equation to describe this problem, you would set up the following proportion:

$$\frac{x \text{ mol O}_2}{0.50 \text{ mol H}_2} = \frac{1 \text{ mol O}_2}{2 \text{ mol H}_2}$$

The given quantity, 0.50 mole of hydrogen, is already in moles, so Step 2 is also completed. We set up a proportion to help complete Step 3. From the balanced equation, we know that 1 mole of oxygen reacts with 2 moles of hydrogen. Similarly, we want to determine the x moles of oxygen needed to react with 0.50 moles of hydrogen. The set up

proportion would be similar to the one above. We can then solve the proportion by multiplying the denominator from the left side to both sides of the equal sign. In this case, you will find that $x = 0.25$ moles of O_2 .

Example:

Pentane, C_5H_{12} , reacts with oxygen gas to produce carbon dioxide and water. How many grams of carbon dioxide will be produced by the reaction of 108.0 grams of pentane?

Step 1: Write and balance the equation.

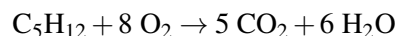

Step 2: Convert the given quantity to moles.

$$\frac{108.0 \text{ g}}{72.0 \text{ g/mol}} = 1.50 \text{ mol } C_5H_{12}$$

Step 3: Set up and solve the proportion to find moles of unknown.

$$\frac{x \text{ mol } CO_2}{1.50 \text{ mol } C_5H_{12}} = \frac{5 \text{ mol } CO_2}{1 \text{ mol } C_5H_{12}}$$

Therefore, $x \text{ mol } CO_2 = 7.50$.

Step 4: Convert the unknown moles to requested units (grams).

$$\text{grams } CO_2 = (7.50 \text{ mol}) \cdot (44.0 \text{ g/mol}) = 330. \text{ grams}$$

Example:

Aluminum hydroxide reacts with sulfuric acid to produce aluminum sulfate and water. How many grams of aluminum hydroxide are necessary to produce 108 grams of water?

Step 1: Write and balance the equation.

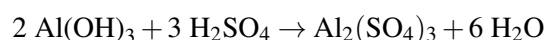

Step 2: Convert the given quantity to moles.

$$\frac{108.0 \text{ g}}{18.0 \text{ g/mol}} = 6.00 \text{ mol } H_2O$$

Step 3: Set up and solve the proportion to find moles of unknown.

$$\frac{x \text{ mol } Al(OH)_3}{6.00 \text{ mol } H_2O} = \frac{2 \text{ mol } Al(OH)_3}{6.00 \text{ mol } H_2O}$$

Therefore, $x \text{ mol } Al(OH)_3 = 2.00$.

Step 4: Convert the moles of unknown to grams.

$$\text{grams } Al(OH)_3 = (2.00 \text{ mol}) \cdot (78.0 \text{ g/mol}) = 156 \text{ grams}$$

Example:

15.0 grams of chlorine gas is bubbled through liquid sulfur to produce liquid disulfur dichloride. How much product is produced in grams?

Step 1: Write and balance the chemical equation.

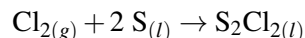

Step 2: Convert the given quantity to moles.

$$\frac{15.0 \text{ g}}{70.9 \text{ g/mol}} = 0.212 \text{ mol}$$

Step 3: Set up and solve the proportion to find moles of unknown.

$$\frac{x \text{ mol S}_2\text{Cl}_2}{0.212 \text{ mol Cl}_2} = \frac{1 \text{ mol S}_2\text{Cl}_2}{1 \text{ mol Cl}_2}$$

Therefore, $x \text{ mol S}_2\text{Cl}_2 = 0.212$.

Step 4: Convert the moles of unknown to grams.

$$\text{grams S}_2\text{Cl}_2 = (0.212 \text{ mol}) \cdot (135 \text{ g/mol}) = 28.6 \text{ grams}$$

Example:

A thermite reaction occurs between elemental aluminum and iron(III) oxide to produce aluminum oxide and elemental iron. The reaction releases enough heat to melt the iron that is produced. If 500. g of iron is produced in the reaction, how much iron(III) oxide was used as reactant?

Step 1: Write and balance the chemical equation.

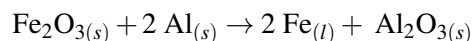

Step 2: Convert the given quantity to moles.

$$\frac{500. \text{ g}}{55.9 \text{ g/mol}} = 8.95 \text{ mol}$$

Step 3: Set up and solve the proportion to find moles of unknown.

$$\frac{x \text{ mol Fe}_2\text{O}_3}{8.95 \text{ mol Fe}} = \frac{1 \text{ mol Fe}_2\text{O}_3}{2 \text{ mol Fe}}$$

Therefore, $x \text{ mol Fe}_2\text{O}_3 = 4.48$.

Step 4: Convert the moles of unknown to grams.

$$\text{grams Fe}_2\text{O}_3 = (4.48 \text{ mol}) \cdot (160. \text{ g/mol}) = 717 \text{ grams}$$

Example:

Ibuprofen is a common painkiller used by many people around the globe. It has the formula $\text{C}_{13}\text{H}_{18}\text{O}_2$. If 200. g of ibuprofen is combusted, how much carbon dioxide is produced?

Step 1: Write and balance the chemical equation.

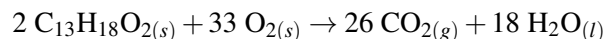

Step 2: Convert the given quantity to moles.

$$\frac{200. \text{ g}}{206 \text{ g/mol}} = 0.967 \text{ mol}$$

Step 3: Set up and solve the proportion to find moles of unknown.

$$\frac{x \text{ mol CO}_2}{0.967 \text{ mol C}_{13}\text{H}_{18}\text{O}_2} = \frac{26 \text{ mol CO}_2}{2 \text{ mol C}_{13}\text{H}_{18}\text{O}_2}$$

Therefore, $x \text{ mol CO}_2 = 12.6$.

Step 4: Convert the moles of unknown to grams.

$$\text{grams CO}_2 = (12.6 \text{ mol}) \cdot (44.0 \text{ g/mol}) = 554 \text{ grams}$$

Example:

If sulfuric acid is mixed with sodium cyanide, the deadly gas hydrogen cyanide is produced. How much sulfuric acid must be reacted to produce 12.5 grams of hydrogen cyanide?

Step 1: Write and balance the chemical equation.

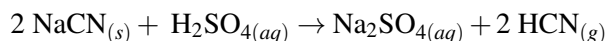

Step 2: Convert the given quantity to moles.

$$\frac{12.5 \text{ g}}{27.0 \text{ g/mol}} = 0.463 \text{ mol}$$

Step 3: Set up and solve the proportion to find moles of unknown.

$$\frac{x \text{ mol H}_2\text{SO}_4}{0.463 \text{ mol HCN}} = \frac{1 \text{ mol H}_2\text{SO}_4}{2 \text{ mol HCN}}$$

Therefore, $x \text{ mol H}_2\text{SO}_4 = 0.232$.

Step 4: Convert the moles of unknown to grams.

$$\text{grams H}_2\text{SO}_4 = (0.232 \text{ mol}) \cdot (98.1 \text{ g/mol}) = 22.7 \text{ grams}$$

A blackboard type discussion of stoichiometry (3e) is available at <http://www.youtube.com/watch?v=EdZtSSJecJc> (9:21).

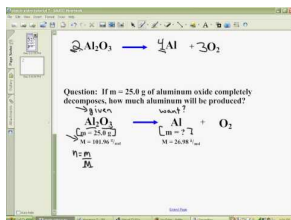

MEDIA

Click image to the left for more content.

Using Dimensional Analysis to Solve Stoichiometry Problems

Many chemists prefer to solve stoichiometry problems with a single line of math instead of writing out the multiple steps. This can be done by using dimensional analysis, also called the factor-label method. Recall that this is simply a method that uses conversion factors to convert from one unit to another. For a review, refer to the section on dimensional analysis in the chapter “Measurement in Chemistry.” In this method, we can follow the cancellation of units to obtain the correct answer.

Let's return to some of the problems from the previous section and use dimensional analysis to solve them. For instance: 15.0 g of chlorine gas is bubbled through liquid sulfur to produce disulfur dichloride. How much product is produced in grams?

Step 1: As always, the first step is to correctly write and balance the equation:

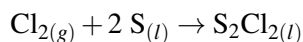

Step 2: Identify what is being given (for this question, 15.0 g of Cl_2 is the given) and what is asked for (grams of S_2Cl_2).

Step 3: Next, use the correct factors that allow you to cancel the units you don't want and get the unit you do want:

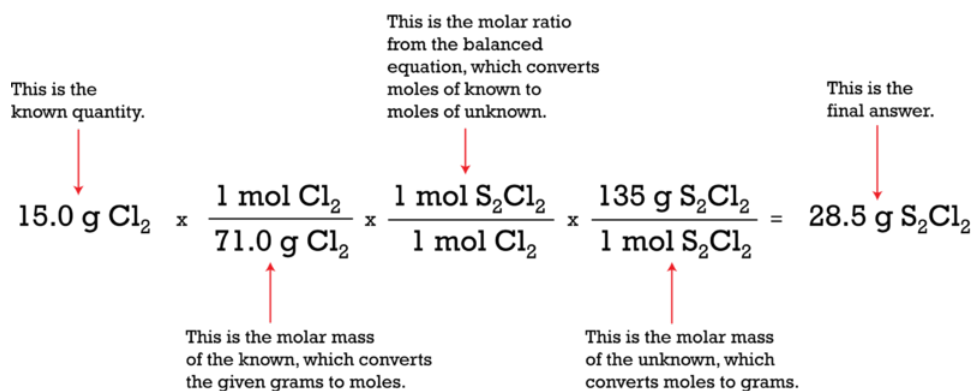

Example:

Consider the thermite reaction again. This reaction occurs between elemental aluminum and iron(III) oxide, releasing enough heat to melt the iron that is produced. If 500.0 g of iron is produced in the reaction, how much iron(III) oxide was placed in the original container?

Step 1: Write and balance the equation:

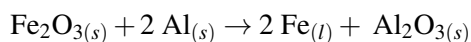

Step 2: Determine what is given and what needs to be calculated:

given = 500. g of Fe calculate = grams of Fe_2O_3

Step 3: Set-up the dimensional analysis system:

$$500. \text{g Fe} \cdot \frac{1 \text{ mol Fe}}{55.85 \text{ g Fe}} \cdot \frac{1 \text{ mol Fe}_2\text{O}_3}{2 \text{ mol Fe}} \cdot \frac{159.7 \text{ g Fe}_2\text{O}_3}{1 \text{ mol Fe}_2\text{O}_3} = 717 \text{ g Fe}_2\text{O}_3$$

Example:

Ibuprofen is a common painkiller used by many people around the globe. It has the formula $\text{C}_{13}\text{H}_{18}\text{O}_2$. If 200. g of Ibuprofen is combusted, how much carbon dioxide is produced?

Step 1: Write and balance the equation:

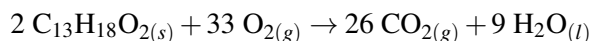

Step 2: Determine what is given and what needs to be calculated:

given = 200. g of ibuprofen calculate = grams of CO_2

Step 3: Set-up the dimensional analysis system:

$$200. \text{ g C}_{13}\text{H}_{18}\text{O}_2 \cdot \frac{1 \text{ mol C}_{13}\text{H}_{18}\text{O}_2}{206.3 \text{ g C}_{13}\text{H}_{18}\text{O}_2} \cdot \frac{26 \text{ mol CO}_2}{2 \text{ mol C}_{13}\text{H}_{18}\text{O}_2} \cdot \frac{44.1 \text{ g CO}_2}{1 \text{ mol CO}_2} = 555 \text{ g CO}_2$$

Example:

If sulfuric acid is mixed with sodium cyanide, the deadly gas hydrogen cyanide is produced. How much sulfuric acid must be placed in the container to produce 12.5 g of hydrogen cyanide?

Step 1: Write and balance the equation:

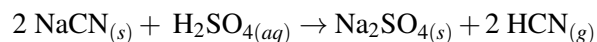

Step 2: Determine what is given and what needs to be calculated:

$$\text{given} = 12.5 \text{ g HCN} \quad \text{calculate} = \text{grams of H}_2\text{SO}_4$$

Step 3: Set-up the dimensional analysis system:

$$12.5 \text{ g HCN} \cdot \frac{1 \text{ mol HCN}}{27.0 \text{ g HCN}} \cdot \frac{1 \text{ mol H}_2\text{SO}_4}{2 \text{ mol HCN}} \cdot \frac{98.06 \text{ g H}_2\text{SO}_4}{1 \text{ mol H}_2\text{SO}_4} = 22.7 \text{ g H}_2\text{SO}_4$$

Lesson Summary

- The coefficients in a balanced chemical equation represent the relative amounts of each substance in the reaction.
- When the moles of one substance in a reaction is known, the coefficients of the balanced equation can be used to determine the moles of all the other substances.
- Mass-mass calculations can be done using dimensional analysis.

Review Questions

1. How many moles of water vapor can be produced from 2 moles of ammonia for the following reaction between ammonia and oxygen: $4 \text{ NH}_{3(g)} + 5 \text{ O}_{2(g)} \rightarrow 4 \text{ NO}_{(g)} + 6 \text{ H}_2\text{O}_{(g)}$?
 - a. 3 mol
 - b. 6 mol
 - c. 12 mol
 - d. 24 mol
2. How many moles of bismuth(III) oxide can be produced from 0.625 mol of bismuth in the following reaction: $\text{Bi}_{(s)} + \text{O}_{2(g)} \rightarrow \text{Bi}_2\text{O}_{3(s)}$? (Note: equation may not be balanced.)
 - a. 0.313 mol
 - b. 0.625 mol
 - c. 1 mol
 - d. 1.25 mol
 - e. 2 mol
3. For the following reaction, balance the equation and then determine the mole ratio of moles of B(OH)_3 to moles of water: $\text{B}_2\text{O}_{3(s)} + \text{H}_2\text{O}_{(l)} \rightarrow \text{B(OH)}_{3(s)}$.

- 1 : 1
 - 2 : 3
 - 3 : 2
 - None of the above.
- Write the balanced chemical equation for the reactions below and find the indicated molar ratio.
 - Gaseous propane (C_3H_8) combusts to form gaseous carbon dioxide and water. Find the molar ratio of O_2 to CO_2 .
 - Solid lithium reacts with an aqueous solution of aluminum chloride to produce aqueous lithium chloride and solid aluminum. Find the molar ratio of $\text{AlCl}_3(\text{aq})$ to $\text{LiCl}(\text{aq})$.
 - Gaseous ethane (C_2H_6) combusts to form gaseous carbon dioxide and water. Find the molar ratio of $\text{CO}_2(\text{g})$ to $\text{O}_2(\text{g})$.
 - An aqueous solution of ammonium hydroxide reacts with an aqueous solution of phosphoric acid to produce aqueous ammonium phosphate and water. Find the molar ratio of $\text{H}_3\text{PO}_4(\text{aq})$ to $\text{H}_2\text{O}(\text{l})$.
 - Solid rubidium reacts with solid phosphorous to produce solid rubidium phosphide. Find the molar ratio of $\text{Rb}(\text{s})$ to $\text{P}(\text{s})$.
 - For the given reaction (unbalanced): $\text{Ca}_3(\text{PO}_4)_2 + \text{SiO}_2 + \text{C} \rightarrow \text{CaSiO}_3 + \text{CO} + \text{P}$
 - how many moles of silicon dioxide are required to react with 0.35 mol of carbon?
 - how many moles of calcium phosphate are required to produce 0.45 mol of calcium silicate?
 - For the given reaction (unbalanced): $\text{FeS} + \text{O}_2 \rightarrow \text{Fe}_2\text{O}_3 + \text{SO}_2$
 - how many moles of iron(III) oxide are produced from 1.27 mol of oxygen?
 - how many moles of iron(II) sulfide are required to produce 3.18 mol of sulfur dioxide?
 - Write the following balanced chemical equation. Ammonia and oxygen are allowed to react in a closed container to form nitrogen and water. All species present in the reaction vessel are in the gas state.
 - How many moles of ammonia are required to react with 4.12 mol of oxygen?
 - How many moles of nitrogen are produced when 0.98 mol of oxygen are reacted with excess ammonia?
 - How many grams of nitric acid will react with 2.00 g of copper(II) sulfide given the following reaction between copper(II) sulfide and nitric acid: $3 \text{CuS}(\text{s}) + 8 \text{HNO}_3(\text{aq}) \rightarrow 3 \text{Cu}(\text{NO}_3)_2(\text{aq}) + 2 \text{NO}(\text{g}) + 4 \text{H}_2\text{O}(\text{l}) + 3 \text{S}(\text{s})$?
 - 0.49 g
 - 1.31 g
 - 3.52 g
 - 16.0 g
 - When properly balanced, what mass of iodine is needed to produce 2.5 g of sodium iodide in the following equation: $\text{I}_2(\text{aq}) + \text{Na}_2\text{S}_2\text{O}_3(\text{aq}) \rightarrow \text{Na}_2\text{S}_4\text{O}_6(\text{aq}) + \text{NaI}(\text{aq})$?
 - 1.0 g
 - 2.1 g
 - 2.5 g
 - 8.5 g
 - Donna was studying the following reaction for a stoichiometry project: $\text{S}(\text{s}) + 3 \text{F}_2(\text{g}) \rightarrow \text{SF}_6(\text{s})$ She wondered how much she could obtain if she used 3.5 g of fluorine. What mass of $\text{SF}_6(\text{s})$ would she obtain from the calculation using this amount of fluorine?
 - 3.5 g
 - 4.5 g
 - 10.5 g
 - 13.4 g
 - Aqueous solutions of aluminum sulfate and sodium phosphate are placed in a reaction vessel and allowed to react. The products of the reaction are aqueous sodium sulfate and solid aluminum phosphate.

- a. Write a balanced chemical equation to represent the above reaction.
 - b. How many grams of sodium phosphate must be added to completely react all of 5.00 g of aluminum sulfate?
 - c. If 3.65 g of sodium phosphate were placed in the container, how many grams of sodium sulfate would be produced?
12. For the given reaction (unbalanced): $\text{Ca}(\text{NO}_3)_2 + \text{Na}_3\text{PO}_4 \rightarrow \text{Ca}_3(\text{PO}_4)_2 + \text{NaNO}_3$
- a. how many grams of sodium nitrate are produced from 0.35 g of sodium phosphate?
 - b. how many grams of calcium nitrate are required to produce 5.5 g of calcium phosphate?
13. For the given reaction (unbalanced): $\text{Na}_2\text{S} + \text{Al}(\text{NO}_3)_3 \rightarrow \text{NaNO}_3 + \text{Al}_2\text{S}_3$
- a. how many grams of aluminum sulfide are produced from 3.25 g of aluminum nitrate?
 - b. how many grams of sodium sulfide are required to produce 18.25 g of aluminum sulfide?

14.3 Limiting Reactant

Lesson Objectives

The student will:

- explain what is meant by the terms “limiting reactant” and “excess reactant.”
- determine the limiting reactant when given the mass or the number of moles of the reactants.
- calculate the quantities of products by using the quantity of limiting reactant and mole-mole ratios.

Vocabulary

- excess reactant
- limiting reactant

Introduction

Suppose you were in the business of building tricycles from the components of frames, handlebars, seats, and wheels. After you completed constructing the tricycle, you boxed it up and shipped it. Suppose further that your supply of components consisted of 100 frames, 120 sets of handlebars, 80 seats, and 300 wheels. What is the maximum number of tricycles you could build and ship? You could build a maximum of 80 tricycles because when you run out of seats, you can no longer complete any more tricycles. The number of tricycles you could build will be limited by the number of seats you have available. In other words, the seats are the limiting component in your tricycle construction. The other components, the ones you have more than enough of, are said to be in excess. If you received a shipment of 100 more seats, could you build 100 more tricycles? No, because now one of the other components would become the limiting component.

In the chemical reactions that you have been working with, when you were given the amount of one substance involved in the reaction, it was assumed that you had exactly the required amount of all the other reagents. In this next section, you will be given the amounts of all the reagents, but not in the correct reacting amounts. You will need to determine which of the reactants limits the amount of product that can be formed, as well as how much product can be produced.

Limiting and Excess Reactants

The **limiting reactant** is the one that is used up first in the reaction. Consequently, limiting reactants determine the maximum amount of product that can be formed. An **excess reactant** is any reactant present in an amount that is more than enough to react with the limiting reactant. Some excess reactant remains after the limiting reactant has been used up. Chemists often add one reactant in excess in order to make sure that the limiting reactant is completely

consumed. For example, if we wanted to find out how much $\text{CO}_{2(g)}$ we would obtain if we combusted an aspirin tablet, we would use excess oxygen to make sure that the entire aspirin tablet reacted.

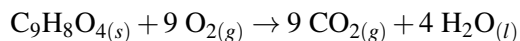

The limiting reagent is the aspirin tablet because it is used up in the experiment. Oxygen is the excess reactant.

Let's look at another example. When you take a piece of aluminum foil and place it into a solution of copper(II) chloride, heat and gas are given off. When the reaction is completed, the blue color of the copper(II) chloride solution fades and a brownish solid (copper) is produced. What is the maximum number of grams of copper that can be produced when 53.96 grams of aluminum are reacted with 134.4 grams of copper(II) chloride?

The reaction is:

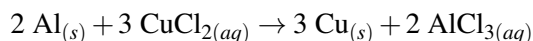

Since 53.96 grams of Al is equivalent to 2 moles of Al and 134.44 grams of CuCl_2 is equivalent to 3 moles, we know that both reactants will be completely used up. As a result, 3 moles of Cu, or 187.3 grams, will be produced.

If we only had 10.0 grams of Al instead, what is the maximum number of grams of copper that can be produced? Assuming we still have 134.44 grams of CuCl_2 , then it is obvious that the Al is the limiting reactant. By doing a mass-mass calculation based on the amount of the limiting reagent, we can determine that 35.5 grams of Cu will be produced.

Consider another example. Assume that we have 72.0 g of water reacting with 190. g of TiCl_4 .

The balanced equation is:

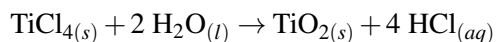

We can see from the balanced equation that one mole of TiCl_4 reacts with two moles of water. The 190. g of TiCl_4 is exactly one mole. Therefore, TiCl_4 will react with two moles, or 36.0 g of water. In this reaction, however, we are given 72.0 g of water. Therefore, the water is in excess and 36.0 g of water will be left over when the reaction is complete.

Example:

You are given 34.0 g of NH_3 and 36.5 g of HCl, which react according to the following balanced equation. Determine the limiting reactant and the reactant in excess.

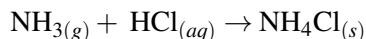

According to the balanced equation, one mole of NH_3 reacts with one mole of HCl. The 34.0 g of NH_3 is equivalent to two moles, and the 36.5 g of HCl is equivalent to one. Since they react with a ratio of 1 : 1, one mole of HCl will react with one mole of NH_3 . One mole of NH_3 will be left over. As a result, HCl is the limiting reactant, and NH_3 is in excess.

A straightforward way to find the limiting reactant is as follows:

Step 1: Write out the balanced equation.

Step 2: Convert the given amounts of all reactants into moles.

Step 3: Divide the moles of each reactant by its coefficient in the balanced equation. The component with the lowest resulting number is the limiting reactant.

The first two steps might seem obvious, but why do we need to divide by the coefficients? Consider the tricycle analogy from the beginning of this section. Let's say you had 105 frames, 120 handlebars, 100 seats, and 270

wheels. How many tricycles could you build? Even though you have more wheels than any other component, it is still the limiting factor for this problem, because you need three wheels for each tricycle. Thus, the answer would be 90. If we were to write the “synthesis” of a tricycle as a chemical equation, it would read:



If we divide the number of components we have by the coefficients in this “reaction,” we would have the values 105 frames, 120 handlebars, 100 seats, and 90 wheels. Comparing these numbers allow you to quickly see that the wheels are the limiting “reactant.”

Let us look at some examples using real chemical reactions.

Example:

Andrew was working in the lab and mixed a solution containing 25.0 g of HCl with a solution containing 25.0 g of iron(II) sulfide. What is the limiting reagent, and what reagent was in excess?

Step 1: Write the balanced equation:

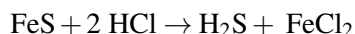

Step 2: Convert given amounts to moles:

$$\begin{aligned} \text{mol FeS: } & \frac{25.0 \text{ g}}{87.9 \text{ g/mol}} = 0.284 \text{ mol FeS} \\ \text{mol HCl: } & \frac{25.0 \text{ g}}{36.5 \text{ g/mol}} = 0.686 \text{ mol HCl} \end{aligned}$$

Step 3: Divide each reactant by its coefficient in the balanced equation:

$$\begin{aligned} \text{FeS: } & \frac{0.284 \text{ mol}}{1} = 0.284 \text{ mol} \\ \text{HCl: } & \frac{0.686 \text{ mol}}{2} = 0.343 \text{ mol} \end{aligned}$$

FeS has the lowest final value, so it is the limiting reagent.

Example:

A student mixed 5.0 g of carbon with 23.0 g iron(III) oxide. What is the limiting reactant, and what reactant was the excess reactant?

Step 1: Write the balanced equation:

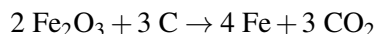

Step 2: Convert given amounts to moles:

$$\begin{aligned} \text{mol C: } & \frac{5.0 \text{ g}}{12.0 \text{ g/mol}} = 0.417 \text{ mol C} \\ \text{mol Fe}_2\text{O}_3: & \frac{23.0 \text{ g}}{159.7 \text{ g/mol}} = 0.144 \text{ mol Fe}_2\text{O}_3 \end{aligned}$$

Step 3: Divide each reactant by its coefficient in the balanced equation:

$$\begin{aligned} \text{C: } & \frac{0.417 \text{ mol}}{3} = 0.139 \text{ mol} \\ \text{mol Fe}_2\text{O}_3: & \frac{0.144 \text{ mol}}{2} = 0.0720 \text{ mol} \end{aligned}$$

mol Fe₂O₃ has the lowest final value, so it is the limiting reagent.

Example:

While working in the lab, Brenda added 5.0 g of aluminum chloride to 7.0 g of silver nitrate in order to work on her double replacement reactions. Her first goal was to determine the limiting reagent. Can you help her determine which reactant is limiting, and which is in excess given the balanced equation?

Step 1: Write the balanced equation:

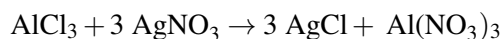

Step 2: Convert given amounts to moles:

$$\begin{aligned} \text{mol AlCl}_3 &: \frac{5.0 \text{ g}}{133 \text{ g/mol}} = 0.037 \text{ mol AlCl}_3 \\ \text{mol AgNO}_3 &: \frac{7.0 \text{ g}}{170. \text{ g/mol}} = 0.041 \text{ mol AgNO}_3 \end{aligned}$$

Step 3: Divide each reactant by its coefficient in the balanced equation:

$$\begin{aligned} \text{mol AlCl}_3 &: \frac{0.037 \text{ mol}}{1} = 0.037 \text{ mol} \\ \text{mol AgNO}_3 &: \frac{0.041 \text{ mol}}{3} = 0.014 \text{ mol} \end{aligned}$$

AgNO₃ has the lowest final value, so it is the limiting reagent. Note that this is the case even though there are fewer moles of AlCl₃. However, since three units of AgNO₃ are used up for each unit of AlCl₃, it is the AgNO₃ that will run out first.

Limiting Reactant and Mass-Mass Calculations

Once we have determined the limiting reactant, we still need to determine the amount of product the limiting reactant will produce. We might also want to know how much of the other reactant we are using and how much is left over. Consider again the example where the student mixed 5.0 g carbon and 23.0 g iron(III) oxide. The reaction is:

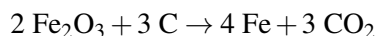

We found that Fe₂O₃ is the limiting reagent and that 23.0 g of Fe₂O₃ is equivalent to 0.144 mol). In order to determine the mass of iron produced, we simply have to perform two additional steps: convert moles of limiting reactant to moles of product (using molar ratios), and convert moles of product to mass (using mass = moles × molar mass).

The mass of iron produced is then:

$$\begin{aligned} \text{mol Fe} &= (0.144 \text{ mol Fe}_2\text{O}_3) \cdot \left(\frac{4 \text{ mol Fe}}{2 \text{ mol Fe}_2\text{O}_3} \right) = 0.288 \text{ mol Fe} \\ \text{mass Fe} &= 0.288 \text{ mol Fe} \cdot 55.85 \text{ g/mol} = 16.1 \text{ g Fe} \end{aligned}$$

Therefore, the mass of Fe formed from this reaction would be 16.1 g.

Now, let's consider two more example.

Example:

Magnesium chloride is used as a fireproofing agent, but it is also a coagulant in tofu – imagine that! Jack was working in the lab one day and mixed 1.93 g of magnesium oxide with 3.56 g of HCl. The equation is given below. What mass of magnesium chloride was formed? (Remember to balance the equation first!)

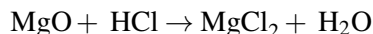

Step 1: Write the balanced equation.

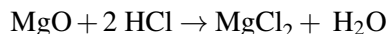

Step 2: Convert given amounts to moles.

$$\text{mol MgO: } \frac{1.93 \text{ g}}{40.3 \text{ g/mol}} = 0.0479 \text{ mol MgCl}_2$$

$$\text{mol HCl: } \frac{3.56 \text{ g}}{36.5 \text{ g/mol}} = 0.0975 \text{ mol HCl}$$

Step 3: Divide each amount by the coefficients from the balanced equation.

$$\text{MgO: } \frac{0.0479 \text{ mol}}{1} = 0.0479 \text{ mol}$$

$$\text{HCl: } \frac{0.0975 \text{ mol}}{2} = 0.0488 \text{ mol}$$

MgO has the lowest final value, so it is the limiting reagent. Thus, we use the values for MgO in our stoichiometric calculations.

Step 4: Convert moles of the limiting reagent to mass of the desired product.

$$\text{mol MgCl}_2: (0.0479 \text{ mol MgO}) \cdot \left(\frac{1 \text{ mol MgCl}_2}{1 \text{ mol MgO}}\right) = 0.0479 \text{ mol MgCl}_2$$

$$\text{mass MgCl}_2: (0.0479 \text{ mol MgCl}_2) \cdot (95.2 \text{ g/mol}) = 4.56 \text{ g MgCl}_2$$

Example:

In the following reaction, 12.8 g of ammonia and 14.5 g of oxygen are allowed to react. How many grams of nitrogen monoxide are formed?

Step 1: Write the balanced equation.

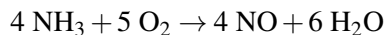

Step 2: Convert given amounts to moles.

$$\text{mol NH}_3: \frac{12.8 \text{ g}}{17.0 \text{ g/mol}} = 0.752 \text{ mol NH}_3$$

$$\text{mol O}_2: \frac{14.5 \text{ g}}{32.0 \text{ g/mol}} = 0.453 \text{ mol O}_2$$

Step 3: Divide each amount by the coefficients from the balanced equation.

$$\text{NH}_3: \frac{0.752 \text{ mol}}{4} = 0.188 \text{ mol}$$

$$\text{O}_2: \frac{0.453 \text{ mol}}{5} = 0.091 \text{ mol}$$

O₂ has the lowest final value, so it is the limiting reagent. Thus, we use the values for O₂ in our stoichiometric calculations.

Step 4: Convert moles of the limiting reagent to mass of the desired product.

$$\text{mol NO: } (0.453 \text{ mol O}_2) \cdot \left(\frac{4 \text{ mol NO}}{5 \text{ mol O}_2}\right) = 0.362 \text{ mol NO}$$

$$\text{mass NO: } (0.362 \text{ mol NO}) \cdot (30.01 \text{ g/mol}) = 10.9 \text{ g NO}$$

Lesson Summary

- The limiting reactant is the one that is used up first in the reaction.
- The limiting reactant limits the amount of product that can form from a chemical reaction.
- An excess reactant is any reactant present in an amount that is more than enough to react with the limiting reactant.
- The excess reactant remains after the limiting reactant has been used up.

Further Reading / Supplemental Links

This website has several video lessons on performing stoichiometry calculations, including problems with a limiting reactant.

- <http://www.kentchemistry.com/moviesfiles/chemguy/advanced/ChemguyStoich.htm>

Review Questions

1. Consider the balanced reaction: $2 \text{Al} + 6 \text{HBr} \rightarrow 2 \text{AlBr}_3 + 3 \text{H}_2$.
 - a. When 3.22 mol of Al reacts with 4.96 mol of HBr, how many moles of H_2 are formed?
 - b. What is the limiting reactant?
 - c. For the reactant in excess, how many moles are left over at the end of the reaction?
2. Write the balanced equation for this reaction: copper(II) chloride reacts with sodium nitrate to form copper(II) nitrate and sodium chloride.
 - a. If 15.0 g of copper(II) chloride react with 20.0 g of sodium nitrate, how much sodium chloride can be formed?
 - b. What is the limiting reactant for this reaction?
 - c. How much of the non-limiting reactant will be left over in this reaction?

14.4 Percent Yield

Lesson Objectives

The student will:

- explain what is meant by the terms “actual yield” and “theoretical yield.”
- calculate the theoretical yield for a chemical reaction when given the amount(s) of reactant(s) available.
- determine the percent yield for a chemical reaction.

Vocabulary

- actual yield
- percent yield
- theoretical yield

Introduction

The amount of product that should be formed when the limiting reactant is completely consumed is called the **theoretical yield**. This is the maximum amount of the product that could form from the quantities of reactants used. In actual practice, however, this theoretical yield is seldom obtained due to side reactions, failure of the reaction to go to completion, and other complications. The actual amount of product produced in a laboratory or industrial reaction is called the **actual yield**. The actual yield is almost always less than the theoretical yield and is often expressed as a percentage of the theoretical yield. This is also referred to as the **percent yield**.

Calculating the Theoretical Yield

When we calculate the amount of product that can be produced from limiting reactants, we are determining the maximum theoretical amount of product we could obtain from the reaction. In other words, the theoretical yield is the maximum amount obtained when all of the limiting reactant has reacted in the balanced chemical equation. You have already been calculating the theoretical yields in the previous section, but let us consider one more example.

Example:

Kerry-Sue is studying the reaction between silver nitrate and potassium sulfide. The unbalanced equation for the reaction is:

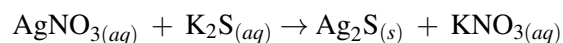

When Kerry-Sue added 5.00 g of the silver nitrate with 2.50 g of potassium sulfide, what was her theoretical yield for silver sulfide?

Notice that this is a limiting reagent problem because we are given two reactant amounts, and we have to determine which of these reactants will run out first.

Step 1: Write the balanced equation.

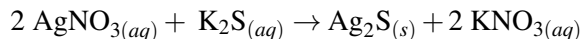

Step 2: Convert given amounts to moles.

$$\text{mol AgNO}_3: \frac{5.00 \text{ g}}{170. \text{ g/mol}} = 0.0294 \text{ mol AgNO}_3$$

$$\text{mol K}_2\text{S}: \frac{2.50 \text{ g}}{110. \text{ g/mol}} = 0.0227 \text{ mol K}_2\text{S}$$

Step 3: Divide each amount by the coefficients from the balanced equation.

$$\text{AgNO}_3: \frac{0.0294 \text{ mol}}{2} = 0.0147 \text{ mol}$$

$$\text{K}_2\text{S}: \frac{0.0227 \text{ mol}}{1} = 0.0227 \text{ mol}$$

AgNO₃ has the lowest final value, so it is the limiting reagent. This means K₂S is in excess. We use the values for AgNO₃ for the rest of our theoretical yield calculations.

Step 4: Convert moles of the limiting reagent to mass of the desired product.

$$\text{mol Ag}_2\text{S}: (0.0294 \text{ mol AgNO}_3) \cdot \frac{1 \text{ mol Ag}_2\text{S}}{2 \text{ mol AgNO}_3} = 0.0147 \text{ Ag}_2\text{S}$$

$$\text{mass Ag}_2\text{S}: (0.0147 \text{ Ag}_2\text{S}) \cdot (248 \text{ g/mol}) = 3.64 \text{ g Ag}_2\text{S}$$

Therefore, when Kerry-Sue did her experiment in the lab, her theoretical yield would have been 3.64 g of Ag₂S_(s).

Alternatively, if we use dimensional analysis the calculation would be:

$$5.00 \text{ g AgNO}_3 \cdot \frac{1 \text{ mol AgNO}_3}{170. \text{ g AgNO}_3} \cdot \frac{1 \text{ mol Ag}_2\text{S}}{2 \text{ mol AgNO}_3} \cdot \frac{248 \text{ g Ag}_2\text{S}}{1 \text{ mol Ag}_2\text{S}} = 3.64 \text{ g Ag}_2\text{S}$$

Calculating Percent Yield

Theoretical yields are the optimum yields if conditions allow all 100% of the reactant to react. If, on the other hand, anything were to happen to jeopardize this, the actual yield will differ from the theoretical yield. Remember that the actual yield is measured, while the theoretical yield is calculated.

The actual yield is almost always less than the theoretical yield, and we often calculate how close this actual yield is to the theoretical yield. The percentage of the theoretical yield that is actually produced (actual yield) is known as the percent yield. The efficiency of a chemical reaction is determined by the percent yield. The percent yield is found using the following formula.

$$\% \text{ yield} = \frac{\text{actual yield}}{\text{theoretical yield}} \times 100\%$$

Example:

A student was able to produce an actual yield of 5.12 g of calcium sulfate from 4.95 g of sulfuric acid and excess calcium hydroxide in the reaction shown below. What was her percent yield?

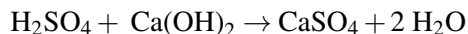

We can calculate the theoretical yield using dimensional analysis.

$$4.95 \text{ g H}_2\text{SO}_4 \cdot \frac{1 \text{ mol H}_2\text{SO}_4}{98.1 \text{ g H}_2\text{SO}_4} \cdot \frac{1 \text{ mol CaSO}_4}{1 \text{ mol H}_2\text{SO}_4} \cdot \frac{136.2 \text{ g CaSO}_4}{1 \text{ mol CaSO}_4} = 6.88 \text{ g CaSO}_4$$

Once we have found the theoretical yield, we can use the actual yield given in the problem to find the percent yield.

$$\% \text{ yield} = \frac{\text{actual yield}}{\text{theoretical yield}} \times 100\% = \frac{5.12 \text{ g}}{6.88 \text{ g}} \times 100\% = 74.4\%$$

Example:

Potassium hydrogen phthalate, $\text{KHC}_8\text{H}_4\text{O}_4$, is a compound used quite frequently in acid-base chemistry for a procedure known as standardization. Standardization has to do with the process of determining the concentration of a standard solution. In a certain experiment, 1.385 g of potassium hydroxide is mixed with 12.50 g of KHP. If 5.26 g of the product, $\text{K}_2\text{C}_8\text{H}_4\text{O}_4$, is produced, what is the percent yield?

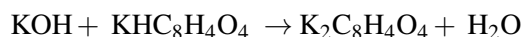

Step 1: Write the balanced equation.

The equation is already balanced, so this step is done.

Step 2: Convert given amounts to moles.

$$\begin{aligned} \text{mol KOH: } & \frac{1.385 \text{ g}}{56.1 \text{ g/mol}} = 0.0247 \text{ mol KOH} \\ \text{mol KHC}_8\text{H}_4\text{O}_4: & \frac{12.5 \text{ g}}{204 \text{ g/mol}} = 0.0613 \text{ mol KHC}_8\text{H}_4\text{O}_4 \end{aligned}$$

Step 3: Divide each amount by the coefficients from the balanced equation.

$$\begin{aligned} \text{mol KOH: } & \frac{0.0247 \text{ mol}}{1} = 0.0247 \text{ mol} \\ \text{mol KHC}_8\text{H}_4\text{O}_4: & \frac{0.0613 \text{ mol}}{1} = 0.0613 \text{ mol} \end{aligned}$$

KOH has the lowest final value, so it is the limiting reagent. We use the values for KOH for the rest of our theoretical yield calculations.

Step 4: Convert moles of the limiting reagent to mass of the desired product.

$$\begin{aligned} \text{mol K}_2\text{C}_8\text{H}_4\text{O}_4: & (0.0247 \text{ mol KOH}) \cdot \frac{1 \text{ mol K}_2\text{C}_8\text{H}_4\text{O}_4}{1 \text{ mol KOH}} = 0.0247 \text{ mol K}_2\text{C}_8\text{H}_4\text{O}_4 \\ \text{mass K}_2\text{C}_8\text{H}_4\text{O}_4: & (0.0247 \text{ mol K}_2\text{C}_8\text{H}_4\text{O}_4) \cdot (212.3 \text{ g/mol}) = 5.26 \text{ g K}_2\text{C}_8\text{H}_4\text{O}_4 \end{aligned}$$

Therefore, the theoretical yield of $\text{K}_2\text{C}_8\text{H}_4\text{O}_4$ is 5.98 g. Remember the actual yield given in the question was 5.26 g. Now let's calculate the percent yield.

$$\% \text{ yield} = \frac{\text{actual yield}}{\text{theoretical yield}} \cdot 100\% = \frac{5.26 \text{ g}}{5.98 \text{ g}} \cdot 100\% = 88.0\%$$

Example:

Zeaxanthin is a compound responsible for causing the colors of the maple leaf to change in the fall. It has the formula $\text{C}_{38}\text{H}_{56}\text{O}_2$. In a combustion reaction of 0.95 g of zeaxanthin with excess oxygen, 2.2 g of carbon dioxide was produced. The other product was water. What is the percent yield of CO_2 ?

Step 1: Write the balanced equation.

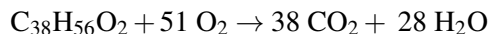

Step 2: Convert given amounts to moles.

$$\text{mol C}_{38}\text{H}_{56}\text{O}_2: \frac{0.95 \text{ g}}{544 \text{ g/mol}} = 0.00174 \text{ mol C}_{38}\text{H}_{56}\text{O}_2$$

Step 3: Divide each amount by the coefficients from the balanced equation.

Since $\text{C}_{38}\text{H}_{56}\text{O}_2$ is reacted with excess oxygen, we already know that $\text{C}_{38}\text{H}_{56}\text{O}_2$ is the limiting reagent. We use the values for $\text{C}_{38}\text{H}_{56}\text{O}_2$ for the rest of our theoretical yield calculations.

Step 4: Convert moles of the limiting reagent to mass of the desired product.

$$\begin{aligned} \text{mol CO}_2: & (0.00174 \text{ mol C}_{38}\text{H}_{56}\text{O}_2) \cdot \frac{38 \text{ mol CO}_2}{1 \text{ mol C}_{38}\text{H}_{56}\text{O}_2} = 0.066 \text{ mol CO}_2 \\ \text{mass CO}_2: & (0.066 \text{ mol CO}_2) \cdot (44 \text{ g/mol}) = 2.9 \text{ g CO}_2 \end{aligned}$$

Therefore, the theoretical yield of CO_2 is 2.9 g. Remember the actual yield given in the question was 2.2 g. Now let's calculate the percent yield.

$$\% \text{ yield} = \frac{\text{actual yield}}{\text{theoretical yield}} \cdot 100\% = \frac{2.2 \text{ g}}{2.9 \text{ g}} \cdot 100\% = 76\%$$

This video is an electronic blackboard presentation of the calculation of a percent yield (**3f; 1b IE**): http://www.youtube.com/watch?v=1L12_TRSqI8 (9:22).



MEDIA

Click image to the left for more content.

Lesson Summary

- The actual yield of a reaction is the actual amount of product that is produced in the laboratory.
- The theoretical yield is the amount of product that is produced under ideal conditions.
- The percentage of the theoretical yield that is actually produced (actual yield) is known as the percent yield.

Review Questions

1. Is it possible for the actual yield to be greater than the theoretical yield?
2. What happens when competing reactions occur while performing an experiment in the lab?
3. If the actual yield is 4.5 g, but the theoretical yield is 5.5 g, what is the percent yield for this data?
4. Solid aluminum and sulfur come together in a reaction to produce 7.5 g of aluminum sulfide: $\text{Al} + \text{S} \rightarrow \text{Al}_2\text{S}_3$. If 5.00 g of each solid react together, what is the percent yield? Remember to balance the reaction first.
 - a. 32.0%
 - b. 53.4%

- c. 96.2%
d. 100.0%
5. In her experiment, Gerry finds she has obtained 3.65 g of lead(II) iodide. She knows that in her reaction, lead(II) nitrate reacted completely with potassium iodide to produce lead(II) iodide and potassium nitrate: $\text{Pb}(\text{NO}_3)_2(\text{aq}) + \text{KI}(\text{aq}) \rightarrow \text{PbI}_2(\text{s}) + \text{KNO}_3(\text{aq})$. The potassium iodide produced is a brilliant yellow colored precipitate. Gerry began with 5.00 g of potassium iodide. What was her percent yield? Remember to balance your equation first.
- a. 26.3%
b. 36.0%
c. 52.6%
d. 72.0%
6. If the percentage yield in the reaction $2 \text{S} + 3 \text{O}_2 \rightarrow 2 \text{SO}_3$ was found to be 78.3% and the actual yield was 1.01 g, what was the original mass of the limiting reagent, oxygen?
- a. 0.515 g
b. 0.773 g
c. 1.01 g
d. 1.29 g
7. Bromine pentafluoride can be produced from a reaction between liquid bromine and fluorine gas. If 3.25 g of fluorine reacts with 2.74 g of bromine to produce 4.83 g of bromine pentafluoride, what is the percent yield of the product?
8. Ammonia can react with oxygen in a reaction that is similar to a combustion reaction. The products, however, are nitrogen monoxide and water, rather than carbon dioxide and water. In the reaction between ammonia and oxygen, 15 g of each reactant are placed in a container, and 10.5 g of nitrogen monoxide was produced. What is the percent yield of the nitrogen monoxide?

All images, unless otherwise stated, are created by the CK-12 Foundation and are under the Creative Commons license CC-BY-NC-SA.

CHAPTER

15**The Behavior of Gases****Chapter Outline**

- 15.1 THE THREE STATES OF MATTER**
 - 15.2 GASES**
 - 15.3 GASES AND PRESSURE**
 - 15.4 GAS LAWS**
 - 15.5 UNIVERSAL GAS LAW**
 - 15.6 MOLAR VOLUME**
 - 15.7 STOICHIOMETRY INVOLVING GASES**
-

15.1 The Three States of Matter

Lesson Objectives

The student will:

- describe the differences in molecular arrangement among solids, liquids, and gases.
- describe the basic characteristic differences among solids, liquids, and gases.

Vocabulary

- ideal gas
- phase
- real gas

Introduction

The kinetic molecular theory allows us to explain the existence of the three phases of matter. In addition, it helps explain the physical characteristics of each phase and why phases change from one to another. The kinetic molecular theory is essential for the explanations of gas pressure, compressibility, diffusion, and mixing. Our explanations for reaction rates and equilibrium in later chapters also rest on the concepts of the kinetic molecular theory.

The Assumptions of the Kinetic Molecular Theory

According to the kinetic molecular theory, all matter is composed of tiny particles that are in constant, random, straight-line motion. This motion is constantly interrupted by collisions between the particles and surfaces, as well as collisions between the particles themselves. The rate of motion for the particles is related to the temperature. The velocity of the particles is greater at higher temperatures and lower at lower temperatures.

In our discussions of gases, we will be referring to what are called ideal gases. In an **ideal gas**, we assume that the molecules are points that do not take up any space. We also assume that there are no attractions between molecules. In **real gases**, however, the gas molecules do take up a small amount of space, and there can be slight attractions among the molecules. Later in this chapter, real and ideal gases will be discussed in more detail.

Phases of Matter

Earlier in the chapter “Matter and Energy,” we had discussed how matter can be categorized as mixtures or pure substances. We did not, however, discuss how substances can be found in different phases. Depending on the

temperature and pressure, matter can exist in different forms or states known as **phases**. You are most likely familiar with the phases of dihydrogen oxide (H_2O), known commonly as water. Besides existing as a liquid that we can drink, water can also exist as ice, which is a solid. When we boil water, we are producing water vapor, which is a form of gas.

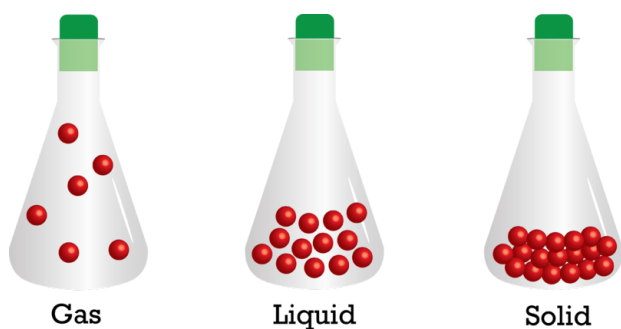

In a solid, the molecules are held in a tightly packed pattern, as seen in the figure above. As a result, the molecules hold a set position in spite of random motion. Molecular motion is reduced to vibrating in place. In comparison, the molecules in a liquid touch each other but are not held in a pattern. The liquid structure has holes in it, which allow molecules to pass each other and change positions in the structure. In a gaseous substance, the molecules are completely separated from each other and move around independently. Most of the volume of a gas is empty space. Scientists also recognize one more phase of matter called plasma. A plasma is a type of ionized gas with unique properties that distinguishes it as a fourth phase of matter. In this text, however, we will be primarily concerned with the solid, liquid, and gas phases.

Characteristics of Solids

The molecular arrangements in the three phases account for the various characteristics that differentiate the phases. For example, the mixing of particles is almost non-existent in solids. This is because the molecules cannot pass by one another in the tightly packed pattern. Solids are essentially incompressible because when a substance is compressed, it is the spaces between molecules that are compressed, not the molecules themselves. Since solids have almost no empty space in their structure, they do not compress. Solids maintain their shape and volume, as seen in the figure below. A 25 mL rectangular piece of copper has the same shape and volume when it is resting on the table top as it does inside a beaker.

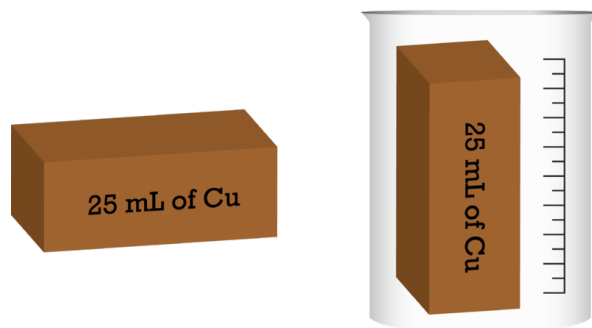

Characteristics of Liquids

In liquids, mixing occurs more readily because there are spaces between the molecules that allow the molecules to pass each other. The spaces between the molecules in liquids are small, so liquids have very little compressibility. Liquids maintain their own volume, but they take the shape of their containers, as seen in the illustration below.

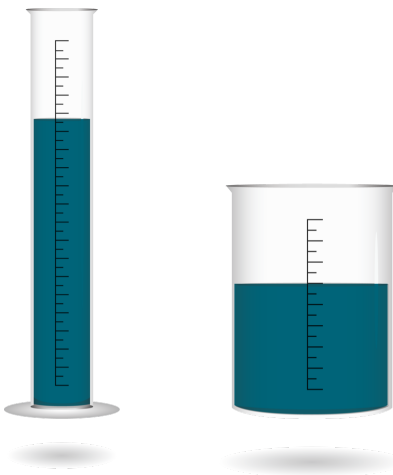

A 25 mL sample of liquid in a graduated cylinder has a volume of 25 mL and the shape of a cylinder. If the 25 mL sample is placed in a beaker, the liquid still has a volume of 25 mL, but now it has the shape of the beaker. The structure of the liquid keeps the particles in touch with each other so that the volume does not change, but because the particles can slide by each other, the particles can flow to fill the shape of the container.

Characteristics of Gases

Mixing in gases is almost instantaneous because there are no inhibitions for particles to pass one another. The volume of a gas is nearly all empty space, so particles are able to move freely. Gases are highly compressible because of the great amount of empty space, which allows the particles to be pushed closer together. Gases do not have either their own volume or their own shape. They take both volume and shape from their container.

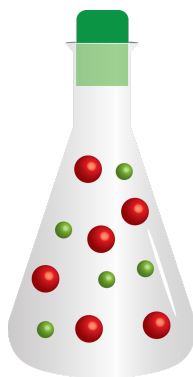

Lesson Summary

- In the solid phase, the molecules are held in a highly organized, tightly packed pattern.
- Due to the tightly packed pattern of molecules in a solid, solids maintain their own shape and volume and do not mix readily.
- In the liquid phase, molecules are in touch with each other but they are loosely packed and may move past each other easily.
- Due to the loosely packed structure of a liquid, liquids maintain their own volume but take the shape of their container. They are also able to mix readily.
- In the gaseous phase, molecules are completely separate from each other.
- The volume of a gas is mostly empty space.

- Due to the structure of gases, they take both the volume and the shape of their container, and they mix almost instantaneously.

Further Reading / Supplemental Links

The *learner.org* website allows users to view the Annenberg series of chemistry videos. You are required to register before you can watch the videos, but there is no charge to register. The video called “A Matter of State” examines matter in its three principle states - gases, liquids, and solids - and relates the visible world to the submicroscopic.

- <http://www.learner.org/resources/series61.html?pop=yes&pid=793#>

This website provides more details about the kinetic molecular theory.

- <http://www.chm.davidson.edu/vce/kineticmoleculartheory/basicconcepts.html>

Review Questions

1. Automobile brakes have a hose full of liquid connecting your brake pedal on one end to the brake pads on the other end. When you press on the brake pedal, the force is transferred through the liquid and presses the brake pads against the wheels to slow or stop them. Brakes that use liquid in this fashion are called hydraulic brakes and the liquid is called hydraulic brake fluid. Why don't they use air in the brake lines instead of liquid?
2. Why would it cause a problem if some air got into your liquid-filled brake lines?
3. If you had a 250 mL container full of helium gas, and you transferred all of the gas into an empty 1.00 liter container, would the 1.00 liter container be full or only 1/4 full?

15.2 Gases

Lesson Objectives

The student will:

- describe the relationship between molecular motion and temperature in Kelvin.
- describe random motion of gaseous molecules and explain how their collisions with surfaces cause pressure on the surface.
- recognize that zero kinetic energy of molecules corresponds to 0 K.

Vocabulary

- joule

Introduction

Gases are tremendously compressible, can exert massive pressures, expand nearly instantaneously into a vacuum, and fill every container they are placed in regardless of size. All of these properties of gases are due to their molecular arrangement and constant molecular motion.

Gases Readily Change Volume

When describing gases, the word “full” loses some of its original meaning. A glass of water may be 1/4 full, 1/2 full, or completely full, but a container containing a gaseous substance is always full. The same amount of gas will fill a quart jar, a gallon jug, a barrel, or even a house. Gas molecules are able to separate further away from each other and spread out uniformly until they fill whatever container they are in. On the other hand, gases can also be compressed to fractions of their original volume. If gas molecules are pushed together to the point that they touch, the substance would no longer be in the gas form and will become a liquid. As a result, one method of converting a gas to a liquid is to cool it, while another method is to compress the gas.

Gases Exert Pressure

The constant random motion of gas molecules causes them to collide with each other and with the walls of their container. These collisions of gas molecules with their surroundings exert a pressure on the surroundings. When you blow up a balloon, the air particles inside the balloon push against the elastic sides of the balloon, causing the balloon to expand. This pressure is produced by air molecules pounding on the inside walls of the balloon.

When you look at the surface of a blown-up balloon, the balloon wall appears to be firm with no visible vibration or movement in its position. It is not apparent that the wall is actually being held in position by billions of collisions with tiny particles. If you place a book on its edge and tilt it over slightly so that it would fall, you can prevent the book from falling by tapping it very rapidly with your finger on the underside. Unlike the balloon surface, the book doesn't stay steady because you can't tap it fast enough to keep it exactly in one position. If you can imagine being able to tap it millions of times per second, you can see how the balloon wall maintains a steady position.

Gas Temperature and Kinetic Energy

Kinetic energy is the energy of motion, so therefore all moving objects contain kinetic energy. The mathematical formula for calculating the kinetic energy of an object is: $KE = \frac{1}{2}mv^2$. This formula applies to all objects, regardless of whether we are talking about the moon moving in its orbit, a baseball flying toward home plate, or a gas molecule banging around in a bottle. As you can see from the formula, kinetic energy is dependent on both the mass of the object and the velocity of the object. For example, the kinetic energy of a 0.20 kg ball moving at 20. m/s would be $KE = \frac{1}{2}(0.20 \text{ kg}) \cdot (20. \text{ m/s})^2 = 40. \frac{\text{kg}\cdot\text{m}^2}{\text{s}^2}$. The units $\frac{\text{kg}\cdot\text{m}^2}{\text{s}^2}$ is also known as joules. The **joule** is the SI unit for energy. The kinetic energy of a molecule would also be calculated in this exact same way. You should note that if the mass of an object is doubled while its velocity remains the same, the kinetic energy of the object would also be doubled. If, on the other hand, the velocity is doubled while the mass remains the same, the kinetic energy would be quadrupled due to the square in the formula.

The molecular motion of molecules is related to their temperature. Recall from the chapter "Measurement in Chemistry" that the thermometer reflects the temperature of the surrounding because the molecules of material surrounding the thermometer will collide with the tube and transfer heat during the process. When you measure the temperature of a group of molecules, what you are actually measuring is their average kinetic energy. The relationship between the average kinetic energy of a group of molecules and the temperature is: $KE_{avg} = \frac{3}{2}RT$, where R is a constant of proportionality and T is the absolute temperature (Kelvin). As a result, when a substance is heated, the average kinetic energy of the molecules increases. Since the mass of the molecules cannot be increased by heating, the velocity of the molecules must be increasing. The relationship between the kinetic energy of an object and its velocity, however, is not linear. Because the velocity is squared in the formula for kinetic energy, the average kinetic energy is doubled when the absolute temperature is doubled, but the velocity is increased only by a factor of 1.4.

It is absolutely vital that you keep in mind that the mathematical relationship between the temperature and the average kinetic energy of molecules only exists when the temperature is expressed in the Kelvin scale. In order for the direct proportion to exist, the molecules must have zero kinetic energy when the temperature is zero. Molecules do *not* have zero kinetic energy at 0°C - balloons and automobile tires do not go flat when the outside temperature reaches 0°C. Instead, the temperature at which molecular motion stops is 0 K (-273°C). If temperature is measured in Kelvin, then the average kinetic energy of a substance at 100 K is exactly double the average kinetic energy of a substance at 50 K. Make sure any work you do with the kinetic energy of molecules is done with Kelvin temperatures.

These two videos contain a discussion of the relationship between absolute zero and kinetic energy (**4a**, **4f**, **4g**): <http://www.youtube.com/watch?v=K4sOfGKEaxs> (4:03), <http://www.youtube.com/watch?v=Mgyp94TZdqQ> (5:55).

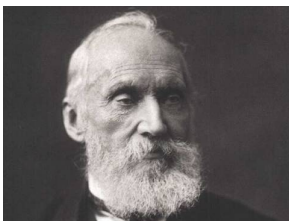

MEDIA

Click image to the left for more content.

**MEDIA**

Click image to the left for more content.

Flaws in videos:

- statement that temperature is related to average molecular velocity rather than average molecular kinetic energy.
- statement that the carbon dioxide molecule has an angular shape rather than linear shape.

Lesson Summary

- Gases readily change volume, as they are both expandable and compressible.
- Collisions of gas molecules with their surroundings exert a pressure on the surroundings.
- The relationship between temperature and the average kinetic energy of molecules can be expressed as $KE = \frac{1}{2}mv^2 = \frac{3}{2}RT$.
- Zero molecular kinetic energy corresponds to 0 K.

Review Questions

1. Ball *A* has a mass of 4 daltons and a speed of 16 meters per second. Ball *B* has a mass of 16 daltons. What velocity is necessary for ball *B* to have the same kinetic energy as ball *A*?
2. Suppose you blow up a balloon, tie off the opening, and place the balloon in a freezer for one hour. When you take the balloon out of the freezer, what will be the most significant difference in its appearance? What do you think will happen as the balloon sits out in the room for a while?
3. Suppose you drive home from school on a hot day and check the pressure in your automobile tires when you get home. You find the tire pressure is over the manufacturer's recommended pressure, so you let some air out of the tires until the pressure is appropriate. What will the tire pressure be in the morning when you go out to go to school?
4. Weather balloons are large balloons that are used to carry meteorological instruments up through the atmosphere and radio back measurements on weather conditions, such as temperature, pressure, and humidity, as it passes through many different altitudes. When these balloons are filled with helium before they are released from earth, they are only a little more than 10% the maximum capacity of the balloon. This provides enough lift to carry the instruments, but the balloon would have more lift if it were filled completely. Why don't they fill the weather balloons to maximum capacity?
5. If molecules of H_2 (molar mass = 2), O_2 (molar mass = 32), and N_2 (molar mass = 28) are all placed in the same container at the same temperature, which molecules will have the greatest average kinetic energy?
6. If molecules of H_2 (molar mass = 2), O_2 (molar mass = 32), and N_2 (molar mass = 28) are all placed in the same container at the same temperature, which molecules will have the greatest velocity?

15.3 Gases and Pressure

Lesson Objectives

The student will:

- define pressure.
- convert requested pressure units.
- read barometers and open and closed-end manometers.

Vocabulary

- atmosphere
- barometer
- manometer
- pascal
- torr

Introduction

As you learned earlier, gases exert a pressure on their surroundings. The pressure is a result of trillions of tiny particles pounding on a surface. This section will define pressure in more details, as well as explore the different ways that pressure is measured.

Pressure

Pressure is defined as the force exerted divided by the area over which the force is exerted:

$$\text{Pressure} = \frac{\text{Force}}{\text{Area}}$$

The concept of force is quite straightforward. Force can be described as a push or pull that causes an object to change its velocity or to change shape. Pressure, however, is a little trickier to understand. Let's consider an example that will illustrate the concept of pressure. Consider the large man and the smaller woman shown in the figure below.



The man weighs 200 pounds and is wearing normal men's shoes. As he walks, at times all of his weight will be exerted on the heel of one shoe. If that heel is 2 inches long and 2 inches wide, then his weight is exerted over an area of 4 inches². The pressure exerted by the heel of his shoe would be:

$$\text{Pressure} = \frac{\text{Force}}{\text{Area}} = \frac{200. \text{ pounds}}{4.0 \text{ inches}^2} = 50. \text{ lbs/in}^2$$

The woman, on the other hand, weighs only 100 pounds, but she is wearing high heels. If the heel on one of her shoes is 1/2 inch by 1/2 inch, then when she walks, there will be times when all her weight is exerted over an area of 1/4 inches². The pressure exerted by one of her heels would be:

$$\text{Pressure} = \frac{\text{Force}}{\text{Area}} = \frac{100. \text{ pounds}}{0.250 \text{ inches}^2} = 400. \text{ lbs/in}^2$$

This huge pressure has little to do with her weight and more to do with the area of her shoe heels. If these two people attempted to walk across the lawn, the 200-pound man would likely have no problem, whereas the 100-pound woman may run into trouble and have her heels sink into the grass. Pressure is not just about the total force exerted, but also about the area over which it is exerted. This is the reason that nails and tent pegs are sharpened on the end. If the end were blunt, the force exerted by a hammer would be insufficient to generate enough pressure to cause the object to be pounded into a piece of wood or the ground.

Atmospheric Pressure

The tremendous pressure that can be exerted by gaseous molecules was once demonstrated by a German physicist named Otto von Guericke, who was the inventor of the air pump. Von Guericke placed two hemispheres about the size of dinner plates together and pumped the air out from between them. Before pumping, the pounding of molecules on both sides of the hemispheres is balanced. When the air between the hemispheres is removed, however, there are no air molecules on the inside of the hemispheres to balance the pounding of air molecules on the outside. As a result, there are only air molecules on the outside pushing the hemispheres together. The force holding the two hemispheres is so strong, teams of horses were unable to pull the hemispheres apart. When von Guericke opened a valve and allowed air back inside, he could easily separate the hemispheres by hand.

The air molecules in our atmosphere exert pressure on every surface they contact. The air pressure of our atmosphere at sea level is approximately 15 lbs/in^2 . This pressure is unnoticed because the air is not only on the outside of the surfaces, it is also inside, which allows the atmospheric air pressure to be balanced. The pressure exerted by our atmosphere quickly will become noticed, however, if the air is removed or reduced inside an object. A common demonstration of air pressure is to use a one-gallon metal can. The can has a few drops of water placed inside the can that is heated. When the water inside the can vaporizes, the water vapor expands to fill the can and pushes air out. The lid is then tightly sealed on the can. As the can cools, the water vapor inside condenses back to liquid water. Because the can is sealed, air molecules cannot get back inside. As a result, the air pressure outside the can slowly crushes the can flat. People, of course, also have atmospheric pressure pressing on them. An average-sized person probably has a total force in excess of 25,000 pounds exerted on them. Fortunately, people also have air inside them to balance the external force exerted by the atmosphere. A device to measure atmospheric pressure, called the **barometer**, was invented in 1643 by an Italian scientist named Evangelista Torricelli (1608 – 1647), who had been a student of Galileo. Torricelli's barometer consists of a glass tube filled with liquid mercury placed in a dish of mercury, as shown in the diagram below.

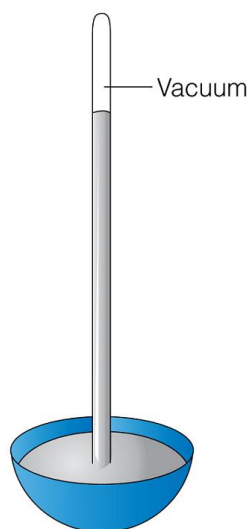

An empty glass tube with one end opened and the other end closed was completely filled with liquid mercury. The dish was also filled two-thirds of the way full with mercury. The open end of the tube was covered by a finger before it was inverted and submerged into the dish of mercury. Since the open end was covered, no air could get into the tube. When the finger was removed, the mercury in the tube fell to a height such that the difference between the surface of the mercury in the dish and the top of the mercury column in the tube was 760 millimeters.

The reason why mercury stays in the tube is because there are air molecules pounding on the surface of the mercury in the dish but not on the top of the mercury in the tube. The volume of empty space in the tube is a vacuum, so there are no air molecules available to exert a balancing pressure. The weight of the mercury in the tube divided by the area of the opening in the tube is exactly equal to the atmospheric pressure. The diameter of the tube makes no difference in determining the atmospheric pressure because doubling the diameter of the tube doubles the volume of mercury in the tube and the weight of the mercury. It also doubles the area over which the force is exerted, so the pressure will be the same for all tubes. No matter the size of the tube you might choose, the air pressure will hold the mercury to the same height.

The height to which the mercury is held would only be 760. millimeters under standard conditions at sea level. The atmospheric pressure changes with the weather conditions, and the height of the mercury in the barometer will reflect the change. Atmospheric pressure also varies with altitude. Higher altitudes have lower air pressure because the air is “thinner” – fewer air molecules per unit volume. In the mountains, at an altitude of 9600 feet, the normal atmospheric pressure will only support a mercury column of 520 millimeters.

Measuring Gas Pressure

There are many different units for measuring and expressing gas pressure. You will need to be familiar with most of them so that you can convert between them easily. Because instruments for measuring pressure often contain a column of mercury, the most commonly used units for pressure are based on the height of the mercury column that the gas can support. As a result, one unit for gas pressure is mm of Hg (millimeters of mercury). Standard atmospheric pressure at sea level is 760. mm of Hg. This unit can be somewhat of a problem. Students, in particular, occasionally leave off the “of Hg,” causing the unit to look like a length unit. To eliminate this problem, the unit was given another name called the **torr**, named in honor of Torricelli. One torr is equivalent to one mm of Hg, so 760 torr is exactly the same as 760 mm of Hg. For certain works, it is more convenient to express gas pressure in terms of multiples of normal atmospheric pressure at sea level. The unit **atmosphere** (atm) was introduced. Pressures expressed in mm in Hg can be converted to atmospheres using the conversion factor 1.00 atmosphere = 760. mm of Hg.

$$1.00 \text{ atm} = 760. \text{ mm of Hg} = 760. \text{ torr}$$

Recall that pressure is defined as force divided by area. In physics, force is expressed in a unit called newton (N), and area is expressed in meters² (m²). Therefore, pressure in physics is expressed in Newtons/meter² (N/m²). This has also been renamed the **pascal** (Pa) and is the SI unit for pressure.

$$1.00 \text{ atm} = 101,325 \text{ N/m}^2 = 101,325 \text{ Pa} = 760 \text{ mm of Hg} = 760 \text{ torr}$$

As it happens, one Pascal is an extremely small pressure, so it is convenient to use kilopascals (kPa) when expressing gas pressure. Therefore, 1.00 atm = 101.325 kPa.

Example:

Convert 425 torr to atm.

Solution:

The conversion factor is 760. torr = 1.00 atm.

$$(425 \text{ torr}) \cdot \left(\frac{1.00 \text{ atm}}{760. \text{ torr}} \right) = 0.559 \text{ atm}$$

Example:

Convert 425 torr to kPa.

Solution:

The conversion factor is 760. torr = 101.325 kPa.

$$(425 \text{ torr}) \cdot \left(\frac{101.325 \text{ kPa}}{760. \text{ torr}} \right) = 56.7 \text{ kPa}$$

Example:

Convert 0.500 atm to mm of Hg.

Solution:

The conversion factor is 1.00 atm = 760. mm of Hg.

$$(0.500 \text{ atm}) \cdot \left(\frac{760. \text{ mm of Hg}}{1.00 \text{ atm}} \right) = 380. \text{ mm of Hg}$$

Example:

Convert 0.500 atm to kPa.

Solution:

The conversion factor is $1.00 \text{ atm} = 101.325 \text{ kPa}$.

$$(0.500 \text{ atm}) \cdot \left(\frac{101.325 \text{ kPa}}{1.00 \text{ atm}} \right) = 50.7 \text{ kPa}$$

You might notice that if you want to measure a gas pressure around 2.0 atm with a barometer, you would need a glass column filled with mercury that was over 1.5 meters high. That would be a fragile and dangerous instrument, as mercury fumes are toxic. If we used water (which is one-thirteenth as dense as mercury) instead, the column would have to be 50 feet high. As a more practical alternative, instruments called **manometers** have been designed to measure gas pressure in flasks. There are two kinds of manometers used: *open-end manometers* and *closed-end manometers*.

We will look at closed-end manometers (illustrated below) first, as they are easier to read. As indicated in the diagram below, the empty space above the mercury level in the tube is a vacuum. Therefore, there are no molecules pounding on the surface of the mercury in the tube. In manometer A, the flask does not contain any gas, so there are no molecules to exert a pressure. In other words, $P_{\text{gas}} = 0$. The mercury level in the outside arm balances the mercury level in the inside arm, so the two mercury levels will be exactly even.

We let the flask of manometer B contain a gas at 1.00 atm pressure. The mercury level in the outside tube (the arm further from the flask) will rise to a height of 760 mm of Hg. The excess mercury in the outside tube balances the gas pressure in the flask. In manometer C, we would read the gas pressure in the flask as 200. mm of Hg. In closed-end manometers, the excess mercury is always in the outside tube, and the height difference in mercury levels will equal the gas pressure in the flask.

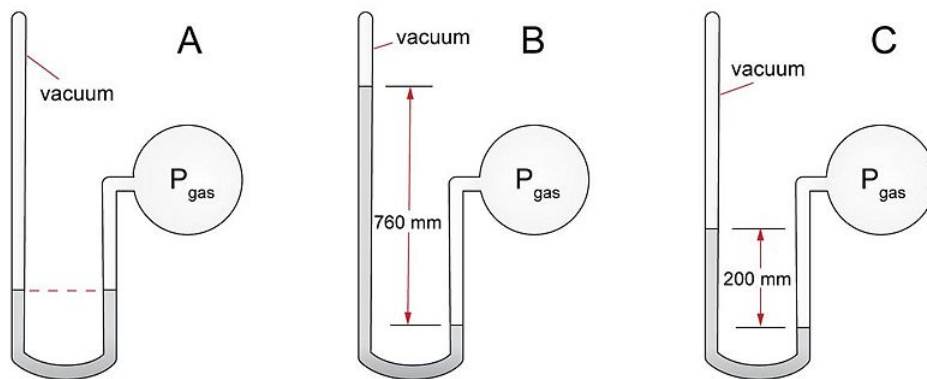

In the open-end manometers illustrated below, the open-end of the tube allows atmospheric pressure to push down on the top of the column of mercury. In manometer A, the pressure inside the flask is equal to atmospheric pressure. The two columns of mercury balance each other, so they are at the same height. Therefore, the atmospheric pressure pushing on the outside column of mercury must equal the gas pressure in the flask pushing on the inside column of mercury.

In order to properly read an open-end manometer, you must know the actual air pressure in the room because atmospheric pressure is not always 760 mm of Hg. In manometer B, the pressure inside the flask balances the atmospheric pressure *plus* an additional pressure of 300. mm of Hg. If the actual atmospheric pressure is 750. mm of Hg, then the pressure in the flask is 1050 mm of Hg. On the other hand, the pressure in the flask of manometer C is less than atmospheric pressure, so the excess mercury is in the inside arm of the manometer (the arm closer to the flask). If atmospheric pressure is 750. mm of Hg, then the pressure in the flask is 650. mm of Hg. For open-end manometers, when the excess mercury is in the outside arm, the height difference is added to atmospheric pressure. When excess mercury is in the inside arm, the height difference is subtracted from atmospheric pressure.

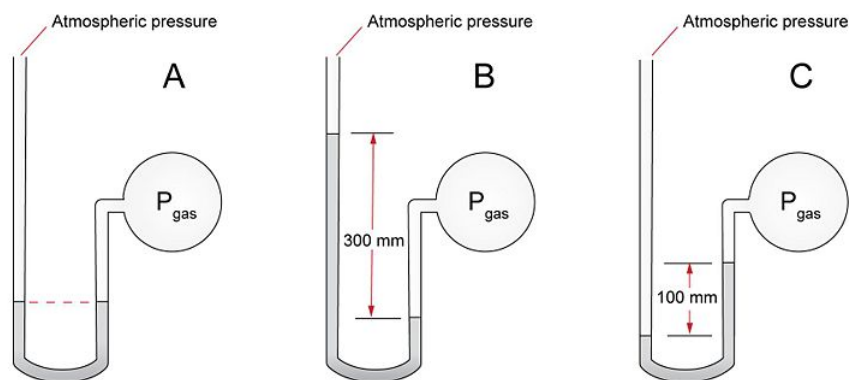

Scientists also use mechanical pressure gauges on occasion. These instruments use the stretching or compression of springs to turn dials, or something similar. While such instruments seem to be less trouble, they must all be calibrated against mercury column instruments and are more susceptible to reactive gases.

Lesson Summary

- Pressure is defined as the force exerted divided by the area over which the force is exerted: $\text{Pressure} = \frac{\text{Force}}{\text{Area}}$.
- The air molecules in our atmosphere exert pressure on every surface they contact.
- There are many different units for measuring and expressing gas pressure, including mm of Hg, torr, atmosphere (atm), and pascal (Pa).
- At sea level, atmospheric pressure is approximately 15 lbs/in², 760 mm of Hg, 760 torr, 1 atm, and 101,325 Pa.
- The barometer is a device to measure atmospheric pressure that consists of a glass tube filled with liquid mercury placed in a dish of mercury.
- A manometer is designed to measure gas pressure in flasks.
- There are two kinds of manometers: an open-end manometer and a closed-end manometer.

Further Reading / Supplemental Links

This video provides an introduction to gases and gas pressure.

- <http://video.google.com/videoplay?docid=8173099266343829057#>

Review Questions

1. The manometer shown is a closed-end manometer filled with mercury. If the atmospheric pressure in the room is 760. mm of Hg and Δh is 65 mm of Hg, what is the pressure in the flask?

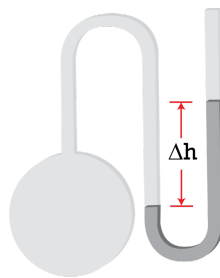

Closed-end Manometer

2. The manometer shown is a closed-end manometer filled with mercury. If the atmospheric pressure in the room is 750. mm of Hg and Δh is 0 mm of Hg, what is the pressure in the flask?

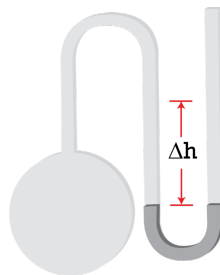

Closed-end Manometer

3. The manometer shown is an open-end manometer filled with mercury. If the atmospheric pressure in the room is 750. mm of Hg and Δh is 65 mm of Hg, what is the pressure in the flask?

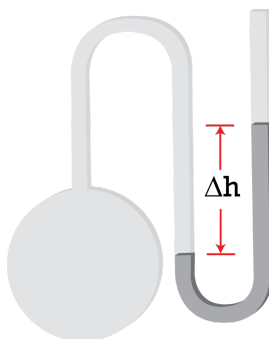

4. The manometer shown is an open-end manometer filled with mercury. If the atmospheric pressure in the room is 760. mm of Hg and Δh is 0 mm of Hg, what is the pressure in the flask?



Open-end Manometer

5. Explain why at constant volume, the pressure of a gas decreases by half when its Kelvin temperature is reduced by half.

15.4 Gas Laws

Lesson Objectives

The student will:

- state Boyle's law, Charles's law, and Gay-Lussac's law.
- solve problems using Boyle's law, Charles's law, and Gay-Lussac's law.
- state the combined gas law.
- solve problems using the combined gas law.

Vocabulary

- Boyle's law
- Charles's law
- combined gas law
- Gay-Lussac's law

Introduction

The gas laws are mathematical expressions that relate the volume, pressure, temperature, and quantity of gas present. They were determined from the results of over 100 years of experimentation. They can also be derived logically by examining the present day definitions of pressure, volume, and temperature.

Boyle's Law

Gases are often characterized by their volume, temperature, and pressure. These characteristics, however, are not independent of each other. Gas pressure is dependent on the force exerted by the molecular collisions and the area over which the force is exerted. In turn, the force exerted by these molecular collisions is dependent on the absolute temperature. The relationships between these characteristics can be determined both experimentally and logically from their mathematical definitions.

The relationship between the pressure and volume of a gas was first determined experimentally by an Irish chemist named Robert Boyle (1627-1691). The relationship between the pressure and volume of a gas is commonly referred to as **Boyle's law**.

When we wish to observe the relationship between two variables, it is absolutely necessary to keep all other variables constant so that the change in one variable can be directly related to the change in the other. Therefore, when the relationship between the volume and pressure of a gas is investigated, the quantity and temperature of the gas must be held constant so that these factors do not contribute to any observed changes.

You may have noticed that when you try to squeeze a balloon, the resistance to squeezing becomes greater as the balloon becomes smaller. That is, the pressure inside the balloon becomes greater when the volume is reduced. This phenomenon can be studied more carefully with an apparatus like the one shown below. This device is a cylinder with a tightly fitted piston that can be raised or lowered. There is also a pressure gauge fitted to the cylinder so that the gas pressure inside the cylinder can be measured. The amount of gas inside the cylinder cannot change, and the temperature of the gas is not allowed to change.

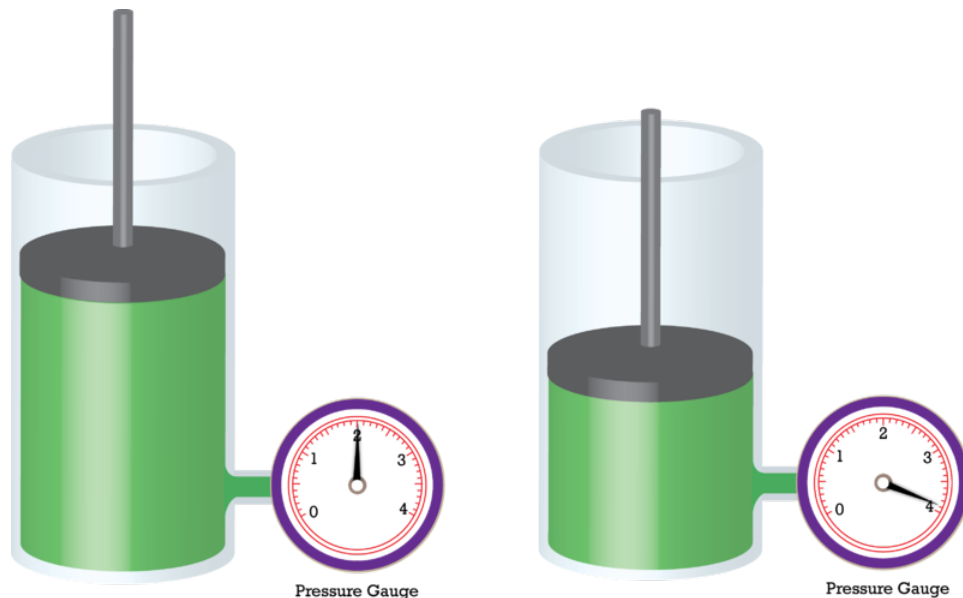

In the picture on the left, a 4.0-liter volume of gas exerts a pressure of 2.0 atm. If the piston is pushed down to decrease the volume of the gas to 2.0 liters, the pressure of the gas is found to be 4.0 atm. The piston can be moved up and down to positions for several different volumes, and the pressure of the gas can be for each of the volumes. Several trials would generate a data set like that shown in **Table 15.1**.

TABLE 15.1: PV Data

Trial	Volume	Pressure
1	8.0 liters	1.0 atm
2	4.0 liters	2.0 atm
3	2.0 liters	4.0 atm
4	1.0 liters	8.0 atm

We might note from casual observation of the data that doubling volume is associated with the pressure being reduced by half. Likewise, if we move the piston to cause the pressure to double, the volume is halved. We can analyze this data mathematically by adding a fourth column to our table – namely, a column showing the product of multiplying pressure times volume for each trial (see **Table 15.2**).

TABLE 15.2: PV Data

Trial	Volume	Pressure	Pressure \times Volume
1	8.0 liters	1.0 atm	8.0 liters \cdot atm
2	4.0 liters	2.0 atm	8.0 liters \cdot atm
3	2.0 liters	4.0 atm	8.0 liters \cdot atm
4	1.0 liters	8.0 atm	8.0 liters \cdot atm

The data in the last column shows that with constant temperature and quantity of gas, the pressure times the volume for this sample of gas yields a constant. A mathematical constant (often represented by k) is a number that does not change even when other quantities in the formula do change. The value of k_1 will change if a different quantity of gas is used or if the trials are carried out at a different temperature, but for a particular mass of a particular gas at a particular temperature, the value of k_1 will always be the same. A subscript 1 is used to distinguish this constant from the constants of other gas laws. This relationship can be shown in a mathematical equation.

$$PV = k_1$$

This equation is a mathematical statement of Boyle's law. This particular equation demonstrates what is called an inverse proportionality. When one of the variables is increased, the other variable will decrease by exactly the same factor. This relationship can be easily seen in a graph like the one shown below.

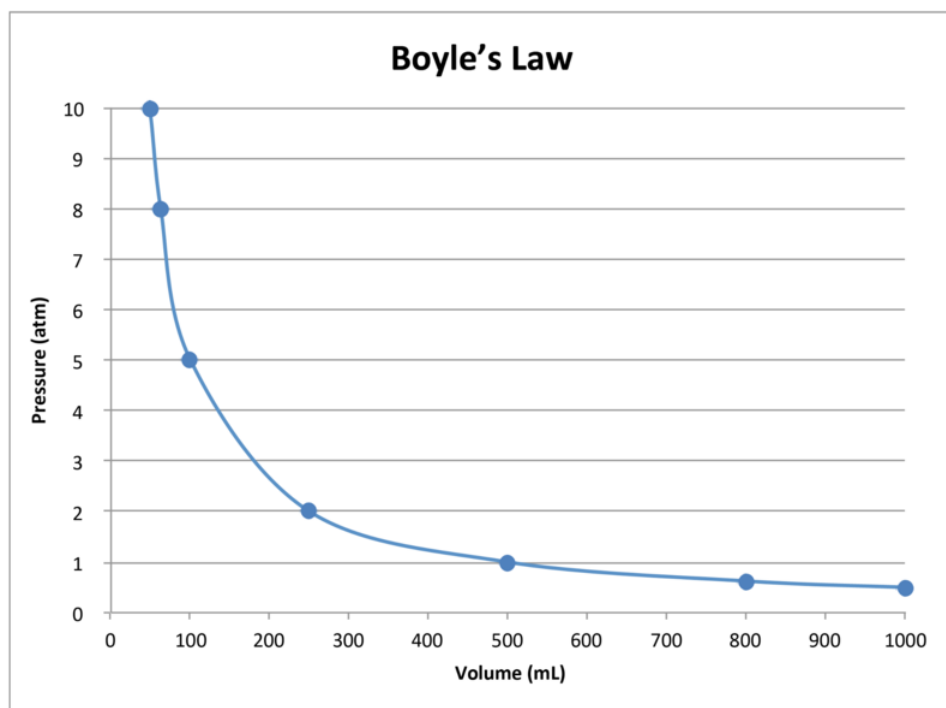

This result matches our logic intuition. If the pressure a gas exerts is equal to the force divided by the area over which it is exerted, we would expect the pressure to increase when we decrease the area but keep the force constant. Similarly, if we maintain the same number of molecules of gas and we keep the same temperature, we expect the total force exerted by the molecules to be the same. As a result, if we expand the volume of the gas, which increases the area over which the force is exerted, we would expect the pressure to decrease.

This video is a laboratory demonstration of Boyle's Law (4c): http://www.youtube.com/watch?v=J_I8Y-i4Axc (1:38).



MEDIA

Click image to the left for more content.

Charles's Law

The relationship between the volume and temperature of a gas was investigated by a French physicist, Jacques Charles (1746-1823). The relationship between the volume and temperature of a gas is often referred to as **Charles's law**.

An apparatus that can be used to study the relationship between the temperature and volume of a gas is shown below. Once again, the sample of gas trapped inside a cylinder so that no gas can get in or out. Thus, we would have a constant mass of gas inside the cylinder. In this setup, we would also place a mass on top of a movable piston to keep a constant force pushing against the gas. This guarantees that the gas pressure in the cylinder will be constant. If the pressure inside increases, the piston will be pushed up until the inside pressure becomes equal to the outside pressure. Similarly, if the inside pressure decreases, the outside pressure will push the cylinder down, decreasing the volume until the two pressures again become the same. This system guarantees constant gas pressure inside the cylinder.

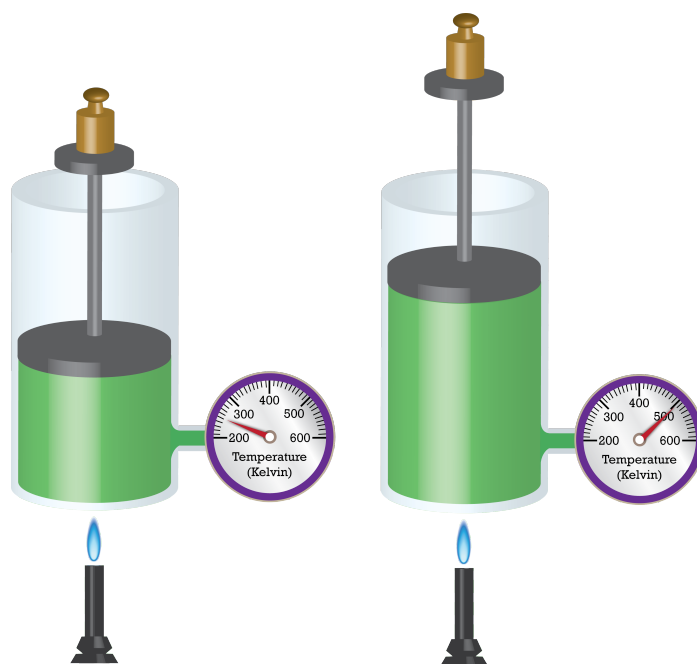

With this set up, we can adjust the temperature and measure the volume at each temperature to produce a data table similar to the one we created for comparing pressure and volume. The picture on the left in the diagram above shows the volume of a sample of gas at 250 K, while the picture on the right shows the volume when the temperature has been raised to 500 K. After two more trials, the collected data is shown in **Table 15.3**.

TABLE 15.3: Charles's Law Data

Trial	Volume	Temperature	Volume/Temp
1	1000. mL	250. K	4.00 mL/K
2	1200. mL	300. K	4.00 mL/K
3	2000. mL	500. K	4.00 mL/K
4	2400. mL	600. K	4.00 mL/K

In order to find a constant from this data, it was necessary to divide each volume with the corresponding Kelvin temperature. The mathematical expression for Charles's Law is:

$$\frac{V}{T} = k_2$$

This relationship is to be expected if we recognize that we are increasing molecular collisions with the walls by raising the temperature. The only way to keep the pressure from increasing is to increase the area over which that force is exerted. This mathematical relationship is known as a direct proportionality. When one variable is increased, the other variable also increases by exactly the same factor.

Historical note: In addition to exploring the relationship between volume and temperature for gases, Jacques Charles was also the first person to fill a large balloon with hydrogen gas and take a solo balloon flight.

This video is a laboratory demonstration of Charles's Law (4c): <http://www.youtube.com/watch?v=IkRIKGN3i0k> (4:02).



MEDIA

Click image to the left for more content.

Gay-Lussac's Law

The relationship between temperature and pressure was investigated by the French chemist, Joseph Gay-Lussac (1778-1850). An apparatus that could be used for this investigation is shown below. In this case, the cylinder does not have a movable piston because it is necessary to hold the volume, as well as the quantity of gas, constant. This apparatus allows us to alter the temperature of a gas and measure the pressure exerted by the gas at each temperature.

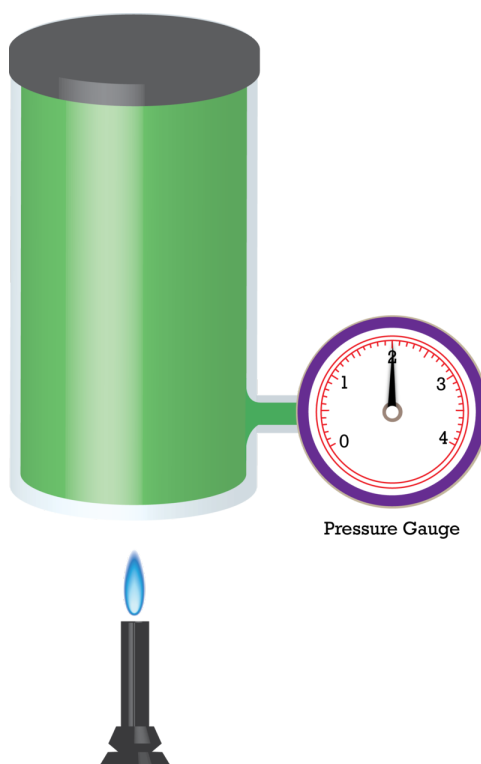

After a series of temperatures and pressures have been measured, **Table 15.4** can be produced. Like Charles's Law, in order to produce a mathematical constant when operating on the data in the table, we must divide pressure by temperature. The relationship, again like Charles's Law, is a direct proportionality.

TABLE 15.4: Pressure vs. Temperature Data

Trial	Temperature	Pressure	Pressure/Temp
1	200. K	600. torr	3.00 torr/K
2	300. K	900. torr	3.00 torr/K
3	400. K	1200. torr	3.00 torr/K
4	500. K	1500. torr	3.00 torr/K

The mathematical form of **Gay-Lussac's Law** is:

$$\frac{P}{T} = k_3K$$

This relationship demonstrates that when the temperature is increased, the pressure must also increase to maintain the value of the constant, k_3 . If the area the molecules are occupying is kept the same, the collisions of the molecules with the surroundings will increase as the temperature increases. This results in a higher pressure.

Standard Conditions for Temperature and Pressure (STP)

It should be apparent by now that expressing a quantity of gas simply by stating its volume is inadequate. Ten liters of oxygen gas could contain any mass of oxygen from 4,000 grams to 0.50 grams depending on the temperature and pressure of the gas. Chemists have found it useful to choose a standard temperature and pressure with which to express gas volume. The standard conditions for temperature and pressure (STP) were chosen to be 0°C (273 K) and 1.00 atm (760 mm of Hg). You will commonly see gas volumes expressed as 1.5 liters of gas under standard conditions or 1.5 liters of gas at STP. Once you know the temperature and pressure conditions of a volume of gas, you can calculate the volume under other conditions.

This video is a black board presentation of some ideal gas law calculations and it includes the definition of standard temperature and pressure (**4d**): http://www.youtube.com/watch?v=GwoX_BemwHs (13:01).

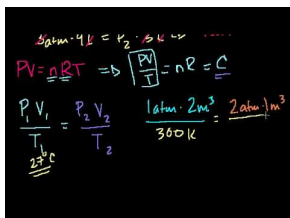

MEDIA

Click image to the left for more content.

The Combined Gas Law

Boyle's law shows how the volume of a gas changes when its pressure is changed with the temperature held constant, while Charles's law shows how the volume of a gas changes when the temperature is changed with the pressure held constant. Is there a formula we can use to calculate the change in volume of a gas if both pressure and temperature change? The answer is yes, as we can use a formula that combines both Boyle's law and Charles's law.

Boyle's law states that for a sample of gas at constant temperature, every *volume times pressure* trial will yield the same constant. We use the subscript 1 to represent one set of conditions, and the subscript 2 to represent a second set of conditions,

$$P_1V_1 = P_2V_2 \quad \text{so} \quad V_2 = V_1 \cdot \frac{P_1}{P_2}$$

We can find a similar expression for Charles's law:

$$\frac{V_1}{T_1} = \frac{V_2}{T_2} \quad \text{so} \quad V_2 = V_1 \cdot \frac{T_2}{T_1}$$

Combining the two equations yields:

$$V_2 = V_1 \cdot \frac{P_1}{P_2} \cdot \frac{T_2}{T_1}$$

The terms in this equation are rearranged and are commonly written in the form shown below. This equation is also known as the **combined gas law**.

$$\frac{P_1V_1}{T_1} = \frac{P_2V_2}{T_2}$$

When solving problems with the combined gas law, temperatures must always be in Kelvin. The units for pressure and volume may be any appropriate units, but the units of pressure must be the same for P_1 and P_2 , and the units of volume for V_1 and V_2 must also be the same.

Example:

A sample of gas has a volume of 400. liters when its temperature is 20.°C and its pressure is 300. mm of Hg. What volume will the gas occupy at STP?

Solution:

Step 1: Assign known values to the appropriate variable.

$$\begin{array}{ll} P_1 = 300. \text{ mm of Hg} & P_2 = 760. \text{ mm of Hg (standard pressure)} \\ V_1 = 400. \text{ liters} & V_2 = x \text{ (the unknown)} \\ T_1 = 20.^\circ\text{C} + 273 = 293 \text{ K} & T_2 = 0^\circ\text{C} + 273 = 273 \text{ K} \end{array}$$

Step 2: Solve the combined gas law for the unknown variable.

$$\frac{P_1V_1}{T_1} = \frac{P_2V_2}{T_2} \quad \text{so} \quad V_2 = \frac{P_1V_1T_2}{P_2T_1}$$

Step 3: Substitute the known values into the formula and solve for the unknown.

$$V_2 = \frac{(300. \text{ mm of Hg}) \cdot (400. \text{ L}) \cdot (273 \text{ K})}{(760. \text{ mm of Hg}) \cdot (293 \text{ K})} = 147 \text{ liters}$$

Example:

A sample of gas occupies 1.00 liter under standard conditions. What temperature would be required for this sample of gas to occupy 1.50 liters and exert a pressure of 2.00 atm?

Step 1: Assign known values to the appropriate variable.

$$\begin{aligned} P_1 &= 1.00 \text{ atm (standard pressure)} & P_2 &= 2.0 \text{ atm} \\ V_1 &= 1.00 \text{ liter} & V_2 &= 1.50 \text{ liters} \\ T_1 &= 273 \text{ K (standard temperature)} & T_2 &= x \text{ (unknown)} \end{aligned}$$

Step 2: Solve the combined gas law for the unknown variable.

$$\frac{P_1 V_1}{T_1} = \frac{P_2 V_2}{T_2} \quad \text{so} \quad T_2 = \frac{P_2 V_2 T_1}{P_1 V_1}$$

Step 3: Substitute the known values into the formula and solve for the unknown.

$$T_2 = \frac{(2.00 \text{ atm}) \cdot (1.50 \text{ L}) \cdot (273 \text{ K})}{(1.00 \text{ atm}) \cdot (1.00 \text{ L})} = 819 \text{ K}$$

Example:

A 1.00 liter sample of oxygen gas under standard conditions has a density of 1.43 g/L. What is the density of oxygen gas at 500. K and 760. torr?

Solution:

You can find the mass of oxygen in the 1.00 liter sample by multiplying volume times density, which yields a mass of 1.43 grams. Changing the temperature and/or pressure of a sample of gas changes its volume and therefore its density, but it does *not* change the mass. Therefore, when the new volume of the gas is found, the mass of oxygen gas in it will still be 1.43 grams. The density under the new conditions can be found by dividing the mass by the volume the gas now occupies.

Step 1: Assign known values to the appropriate variable.

$$\begin{aligned} P_1 &= 760. \text{ torr} & P_2 &= 760. \text{ torr} \\ V_1 &= 1.00 \text{ L} & V_2 &= x \text{ unknown} \\ T_1 &= 273 \text{ K} & T_2 &= 500. \text{ K} \end{aligned}$$

Step 2: Solve the combined gas law for the unknown variable.

$$V_2 = \frac{P_1 V_1}{T_1} = \frac{P_2 V_2}{T_2} \quad \text{so} \quad \frac{P_1 V_1 T_2}{P_2 T_1}$$

Step 3: Substitute the known values into the formula and solve for the unknown.

$$\frac{(760. \text{ torr}) \cdot (1.00 \text{ L}) \cdot (500. \text{ K})}{(760. \text{ torr}) \cdot (273 \text{ K})} = 1.83 \text{ liters}$$

$$D_{O_2 @ 500 \text{ K}} = \frac{\text{mass}}{\text{volume}} = \frac{1.43 \text{ g}}{1.83 \text{ L}} = 0.781 \text{ g/L}$$

Lesson Summary

- Boyle's law states that for a gas at constant temperature, volume is inversely proportional to pressure.
- Charles's law states that for a gas at constant pressure, volume is directly proportional to temperature.
- Gay-Lussac's law states that for a gas at constant volume, pressure is directly proportional to temperature.
- The volume of a mass of gas is dependent on the temperature and pressure. Therefore, these conditions must be given along with the volume of a gas.
- Standard conditions for temperature and pressure are 0°C and 1.0 atm.
- The combined gas law relates the temperature, pressure, and volume of a gas.

Review Questions

1. When a sample of gas is placed in a larger container at the same temperature, what happens to the total force of the molecules hitting the walls?
2. When a sample of gas is placed in a larger container at the same temperature, what happens to the pressure exerted by the gas?
3. If X and Y are quantities that are related to each other by inverse proportion, what will the value of Y become when the value of X is increased by a factor of five?
4. Under what conditions will the value for the constant, K , change in the equation for Boyle's Law, $PV = K$.
5. A sample of gas has a volume of 500. mL under a pressure of 500. mm of Hg. What will be the new volume of the gas if the pressure is reduced to 300. mm of Hg at constant temperature?
6. A graph is made illustrating Charles's Law. Which line would be appropriate assuming temperature is measured in Kelvin?

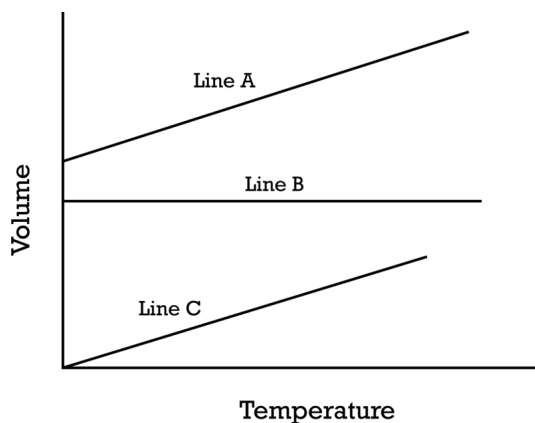

7. At constant pressure, the temperature of a sample of gas is decreased. Will the volume of the sample
 - a. increase
 - b. decrease
 - c. remain the same?
8. A sample of gas has its temperature increased from -43°C to 47°C at constant pressure. If its volume at -43°C was 500. mL, what is its volume at 47°C ?
9. A gas is confined in a rigid container and exerts a pressure of 250. mm of Hg at a temperature of 17°C . To what temperature must this gas be cooled in order for its pressure to become 216 mm of Hg? Express this temperature in $^{\circ}\text{C}$.
10. What is the abbreviation used to indicate standard conditions for temperature and pressure?
11. A sample of gas has a volume of 500. mL at standard conditions. Find its volume at 47°C and 800. torr.

12. A sample of gas has a volume of 100. L at 17°C and 800. torr. To what temperature must the gas be cooled in order for its volume to become 50.0 L at a pressure of 600. torr?

15.5 Universal Gas Law

Lesson Objectives

The student will:

- solve problems using the universal gas law, $PV = nRT$.
- state Avogadro's law of equal molecules in equal volumes.
- calculate molar mass (M) from $M = gRT/PV$ given mass, temperature, pressure, and volume.

Vocabulary

- Avogadro's law
- universal gas law
- universal gas law constant (R)

Introduction

The individual gas laws (Boyle's, Charles's, and Gay-Lussac's) and the combined gas law all require the quantity of gas remain constant. The universal gas law (sometimes called the ideal gas law) allows us to make calculations when there are different quantities of gas.

Avogadro's Law

Avogadro's law postulates that equal volumes of gas with the same temperature and pressure contain the same number of molecules. Mathematically, this would be written as: $V = k_3 n$, where n represents the number of moles of molecules and k_3 represents a constant. This law was known as Avogadro's hypothesis for the first century of its existence. Since Avogadro's hypothesis can now be demonstrated mathematically, it was decided that it should be called a law instead of a hypothesis. If we think about the definitions of the volumes, pressures, and temperatures for gases, we can also develop Avogadro's conclusion.

Suppose we have a group of toy robots that are all identical in strength. They do not have the same size or look, but they all have exactly the same strength at an assigned task. We arrange a tug-of-war between groups of robots. We arrange the rope so that we can see one end of the rope, but the other end disappears behind a wall. On the visible end, we place eight robots to pull. On the other end, an unknown number of robots will pull. When we say "go," both sides pull with maximum strength, but the rope does *not* move. How many robots are pulling on the hidden end of the rope? Since each robot pulls with the exact same strength, to balance the eight robots we know are on our end, there *must* be eight robots on the other end. We can think of molecules as robots by recognizing that molecules

at the same temperature have exactly the same striking power upon collision. As a result, equal volumes of gas with equal pressures and temperatures must contain an equal number of molecules.

In the early 1800s, the first attempts to assign relative atomic weights to the atoms were accomplished by assigning hydrogen to have an atomic mass of 1.0. and by decomposing compounds to determine the mass ratios in the compounds. Some of the atomic weights found this way were accurate, but many were not. In the 1860s, Stanislao Cannizzaro refined the process of determining relative atomic weights by using Avogadro's law. If gas X and gas Y were heated to the same temperature, placed in equal volume containers under the same pressure (gas would be released from one container until the two containers had the same pressure), Avogadro's conditions would be present. As a result, Cannizzaro could conclude that the two containers had exactly the same number of molecules. The mass of each gas was then determined with a balance (subtracting the masses of the containers), and the relationship between the masses would be the same as the mass relationship of one molecule of X to one molecule of Y . That is, if the total mass of gas X was 10. grams and the total mass of gas Y was 40. grams, then Cannizzaro knew that one molecule of Y must have four times as much mass as one molecule of X . If an arbitrary value such as 1.0 dalton was assigned as the mass of gas X , then the mass of gas Y on that same scale would be 4.0 daltons.

The Universal Gas Law Constant

We have considered three laws that examine how the volume of a gas depends on pressure, temperature, and number of moles of gas (Gay-Lussac's law requires a constant volume).

- Boyle's law: $V = \frac{k_1}{P}$ at constant temperature and constant moles of gas, where k_1 is a constant.
- Charles's law: $V = k_2T$ at constant pressure and constant moles of gas, where k_2 is a constant.
- Avogadro's law: $V = k_3n$ at constant temperature and pressure, where n is the number of moles of gas and k_3 is a constant.

These three relationships can be combined to form the expression $PV = nRT$, where R is the combination of the three constants. The equation is called the **universal gas law** (or the ideal gas law), and R is called the **universal gas law constant**. When the pressure is expressed in atmospheres and the volume in liters, R has the value $0.08206 \text{ L} \cdot \text{atm} \cdot \text{mol}^{-1} \cdot \text{K}^{-1}$. You can convert the value of R into values for any set of units for pressure and volume. Moles, of course, always have the unit moles, while the temperature must always be Kelvin.

In our analysis of gas behavior, we have used a pair of assumptions that are not always true. We have assumed that the volume of the actual molecules in a gas is insignificant compared to the volume of the empty space between molecules. We have treated the molecules as if they were geometric points that took up no space. For most gases, this assumption will be true most of the time, and the gas laws work well. If, however, a gas is highly compressed (at very high pressure), the molecules will be pushed together very closely, with much of the empty space between molecules removed. Under such circumstances, the volume of the molecules becomes significant, and some calculations with the gas laws will be slightly off.

Another assumption that we have used is that the molecules are not attracted to each other so that every collision is a perfectly elastic collision. In other words, we have assumed that no energy is lost during the collision. This assumption also works well most of the time. Even though the molecules do have some attraction for each other, usually the temperature is high enough that the molecular motion readily overcomes any attraction and the molecules move around as if there were no attraction. If, however, we operate with gases at low temperatures (temperatures near the phase change temperature of the gas), the molecular attractions have enough effect to cause our calculations to be slightly off. If a gas follows the ideal gas laws, we say that the gas behaves ideally. Gases behave ideally at low pressure and high temperature. At low temperatures or high pressures, gas behavior may become non-ideal. As a point of interest, if you continue your study of chemistry, you will discover that there is yet another gas law equation for these non-ideal situations.

Example:

A sample of nitrogen gas (N_2) has a volume of 5.56 liters at 0°C and a pressure of 1.50 atm. How many moles of nitrogen are present in this sample?

Solution:

Step 1: Assign known values to the appropriate variable.

$$P = 1.50 \text{ atm}$$

$$V = 5.56 \text{ L}$$

$$n = \text{unknown}$$

$$T = 0^\circ\text{C} + 273 = 273 \text{ K}$$

$$R = 0.08206 \text{ L} \cdot \text{atm} \cdot \text{mol}^{-1} \cdot \text{K}^{-1}$$

Step 2: Solve the combined gas law for the unknown variable.

$$PV = nRT \quad \text{so} \quad n = \frac{PV}{RT}$$

Step 3: Substitute the known values into the formula and solve for the unknown.

$$n = \frac{PV}{RT} = \frac{(1.50 \text{ atm}) \cdot (5.56 \text{ L})}{(0.08206 \text{ L} \cdot \text{atm} \cdot \text{mol}^{-1} \cdot \text{K}^{-1}) \cdot (273 \text{ K})} = 0.372 \text{ mol}$$

Example:

2.00 moles of methane gas (CH_4) are placed in a rigid 5.00 liter container and heated to $100.^\circ\text{C}$. What pressure will be exerted by the methane?

Solution:

Step 1: Assign known values to the appropriate variable.

$$P = \text{unknown}$$

$$V = 5.00 \text{ L}$$

$$n = 2.00 \text{ moles}$$

$$T = 100.^\circ\text{C} + 273 = 373 \text{ K}$$

$$R = 0.08206 \text{ L} \cdot \text{atm} \cdot \text{mol}^{-1} \cdot \text{K}^{-1}$$

Step 2: Solve the combined gas law for the unknown variable.

$$PV = nRT \quad \text{so} \quad P = \frac{nRT}{V}$$

Step 3: Substitute the known values into the formula and solve for the unknown.

$$P = \frac{nRT}{V} = \frac{(2.00 \text{ mol}) \cdot (0.08206 \text{ L} \cdot \text{atm} \cdot \text{mol}^{-1} \cdot \text{K}^{-1}) \cdot (373 \text{ K})}{(5.00 \text{ L})} = 12.2 \text{ atm}$$

Example:

A sample gas containing 0.300 moles of helium at a pressure of 900. torr is cooled to 15°C . What volume will the gas occupy under these conditions?

Note: If we are to use $0.08206 \text{ L} \cdot \text{atm} \cdot \text{mol}^{-1} \cdot \text{K}^{-1}$ for the value of R , then the pressure must be converted from torr to atm.

Solution:

Step 1: Assign known values to the appropriate variable.

$$P = (900. \text{ torr}) \cdot \left(\frac{1.00 \text{ atm}}{760. \text{ torr}}\right) = 1.18 \text{ atm}$$

$$V = \text{unknown}$$

$$N = 0.300 \text{ mole}$$

$$T = 15^\circ\text{C} + 273 = 288 \text{ K}$$

$$R = 0.08206 \text{ L} \cdot \text{atm} \cdot \text{mol}^{-1} \cdot \text{K}^{-1}$$

Step 2: Solve the combined gas law for the unknown variable.

$$PV = nRT \quad \text{so} \quad V = \frac{nRT}{P}$$

Step 3: Substitute the known values into the formula and solve for the unknown.

$$V = \frac{nRT}{P} = \frac{(0.300 \text{ mol}) \cdot (0.08206 \text{ L} \cdot \text{atm} \cdot \text{mol}^{-1} \cdot \text{K}^{-1}) \cdot (373 \text{ K})}{(1.18 \text{ atm})} = 7.08 \text{ liters}$$

For a video example of solving an ideal gas law problem (4h), see <http://www.youtube.com/watch?v=JEsFU7ogbVQ> (4:44).

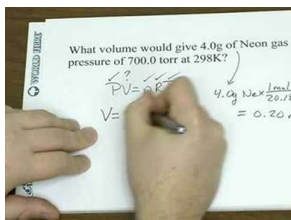
**MEDIA**

Click image to the left for more content.

Molar Mass and the Universal Gas Law

The universal gas law can also be used to determine the molar mass of an unknown gas provided the pressure, volume, temperature, and mass are known. The number of moles of a gas, n , can be expressed as grams/molar mass. If we substitute g/M for n in the universal gas law, we get $PV = \left(\frac{g}{M}\right)RT$ which can be re-arranged to $M = \frac{gRT}{PV}$.

Example:

20.0 grams of an unknown gas occupy 2.00 L under standard conditions. What is the molar mass of the gas?

Solution:

$$\text{molar mass} = \frac{gRT}{PV} = \frac{(20.0 \text{ g}) \cdot (0.08206 \text{ L} \cdot \text{atm} \cdot \text{mol}^{-1} \cdot \text{K}^{-1}) \cdot (273 \text{ K})}{(1.00 \text{ atm}) \cdot (2.00 \text{ L})} = 224 \text{ g/mol}$$

Density and the Universal Gas Law

The density of a gas under a particular set of conditions is the mass of the sample of gas divided by the volume occupied at those conditions, $D = m/V$. In the universal gas law, both the mass of the sample of gas and the volume it occupies are represented. We can substitute density for g/V where it appears in the equation and produce an equation that contains density instead of mass and volume. For example, in the equation $M = \frac{gRT}{PV}$, mass appears in the numerator and volume appears in the denominator. We can substitute D for those two variables and obtain the equation $M = DRT/P$.

Example:

The density of a gas was determined to be 1.95 g/mL at 1.50 atm and 27°C. What is the molar mass of the gas?

Solution

$$\text{molar mass} = \frac{DRT}{P} = \frac{(1.95 \text{ g/L}) \cdot (0.08206 \text{ L} \cdot \text{atm} \cdot \text{mol}^{-1} \cdot \text{K}^{-1}) \cdot (300. \text{ K})}{(1.50 \text{ atm})} = 32.0 \text{ g/mol}$$

Lesson Summary

- Avogadro's law states that equal volumes of gases under the same temperature and pressure contain equal numbers of molecules.
- The universal gas law, also known as the ideal gas law, relates the pressure, volume, temperature, and number of moles of gas: $PV = nRT$.
- The universal gas law assumes that the gas molecules are geometric points that take up no space and that they undergo perfectly elastic collision.
- The universal gas law can also be used to determine the molar mass and the density of an unknown gas.

Further Reading / Supplemental Links

This video reviews how to perform ideal gas law (universal gas law) calculations.

- <http://video.google.com/videoplay?docid=-2010945058854921425#>

Review Questions

1. What conditions of temperature and pressure cause gases to deviate from ideal gas behavior?
2. What volume will 2.00 moles of hydrogen gas occupy at 2.62 atm of pressure and 300.°C?
3. How many moles of gas are required to fill a volume of 8.00 liters at 2.00 atm and 273 K?
4. What is the molar mass of a gas if its density is 1.30 g/L at STP?

15.6 Molar Volume

Lesson Objectives

The student will:

- apply the relationship that 1.00 mole of any gas at standard conditions will occupy 22.4 L.
- convert gas volume at STP to moles and to molecules, and vice versa.
- apply Dalton's law of partial pressures to describe the composition of a mixture of gases.

Vocabulary

- Dalton's law of partial pressure
- diffusion
- Graham's law
- molar volume
- partial pressure

Introduction

When molecules are at the same temperature, they have the same kinetic energy regardless of mass. In this sense, all molecules are created equal (as long as they are at the same temperature). They all exert the same force when they strike a wall. When trapped in identical containers, they will exert the exact same pressure. This is the logic of Avogadro's Law. If we alter this situation a little and say we have the same number of molecules at the same temperature exerting the same pressure, then similar logic allows us to conclude that these groups of molecules must be in equal-sized containers.

Molar Volume of Gases at STP

As you know, 1.00 mole of any substance contains 6.02×10^{23} molecules. We also know that Avogadro's law states that equal volumes of gases under the same temperature and pressure will contain equal number of molecules. With a sort of reverse use of Avogadro's Law, we know then that 6.02×10^{23} molecules of any gas will occupy the same volume under the same temperature and pressure. Therefore, we can say that 1.00 mole of any gas under the same conditions will occupy the same volume. You can find the volume of 1.00 mole of any gas under any conditions by plugging the values into the universal gas law, $PV = nRT$, and solving for the volume. We are particularly interested in the **molar volume**, or the volume occupied by 1.00 mole, of any gas under standard conditions. At STP, we find that:

$$V = \frac{nRT}{P} = \frac{(1.00 \text{ mol}) \cdot (0.08206 \text{ L} \cdot \text{atm} \cdot \text{mol}^{-1} \cdot \text{K}^{-1}) \cdot (273 \text{ K})}{(1.00 \text{ atm})} = 22.4 \text{ liters}$$

This is the volume that 1.00 mole of any gas will occupy at STP. You will be using this number to convert gas volumes at STP to moles, and vice versa. You will use this value often enough to make it worth memorizing.

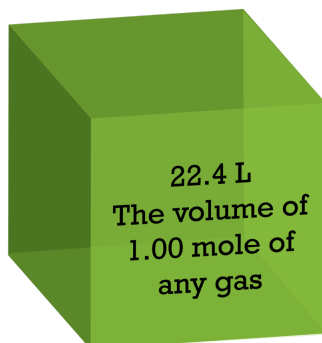
**Example:**

How many moles are present in 100. L of hydrogen gas at STP?

Solution:

$$(100. \text{ L}) \cdot \left(\frac{1.00 \text{ mol}}{22.4 \text{ L}} \right) = 4.46 \text{ liters}$$

Example:

What volume will 100. grams of methane gas (CH_4 , molar mass = 16.0 g/mol) occupy at STP?

Solution:

$$(100. \text{ g}) \cdot \left(\frac{1.00 \text{ mol}}{16.0 \text{ g}} \right) \cdot \left(\frac{22.4 \text{ L}}{1.00 \text{ mol}} \right) = 140. \text{ liters}$$

Dalton's Law of Partial Pressures

The English chemist, John Dalton, in addition to giving us the atomic theory, also studied the pressures of gases when gases are mixed together but do not react chemically. His conclusion is known as **Dalton's law of partial pressures**:

For a mixture of gases in a container, the total pressure exerted is the sum of the pressures that each gas would exert if it were alone.

This can be expressed mathematically as: $P_{TOTAL} = P_1 + P_2 + P_3 + \dots$

In the last section, molecules were described as robots. The robots were identical in their ability to exert force. When a group of diverse molecules are at the same temperature, this analogy works well. In the case of molecules, they don't all look alike, but they have the same average kinetic energy and therefore exert the same force when they collide. If we have 10,000 gaseous molecules at 100°C in a container that exert a pressure of 0.10 atm, then adding

another 10,000 gaseous molecules of any substance at the same temperature to the container would increase the pressure to 0.20 atm. If there are 200 molecules in a container (and at the same temperature), each single molecule is responsible for 1/200th of the total pressure. In terms of the force of collision, it doesn't make any difference if the molecules have different masses. At the same temperature, the smaller molecules are moving faster than the larger ones, so the striking force is the same. It is this ability to exert force that is measured by temperature. We can demonstrate that different sized objects can have the same kinetic energy by calculating the kinetic energy of a golf ball and the kinetic energy of a bowling ball at appropriate velocities. Suppose a 100. gram golf ball is traveling at 60. m/s and a 7,200 gram bowling ball is traveling at 7.1 m/s.

$$KE_{\text{GOLF}} = \frac{1}{2}mv^2 = \frac{1}{2}(0.100 \text{ kg})(60. \text{ m/s})^2 = 180 \text{ Joules}$$

$$KE_{\text{BOWL}} = \frac{1}{2}mv^2 = \frac{1}{2}(7.2 \text{ kg})(7.1 \text{ m/s})^2 = 180 \text{ Joules}$$

The kinetic energies are the same. If these balls were to strike a pressure plate, they would exert exactly the same force. If the balls were invisible, we would not be able to determine which one had struck the plate.

Now suppose we have three one-liter containers labeled A, B, and C. Container A holds 0.20 mole of O₂ gas at 27°C, container B holds 0.50 mole of N₂ gas at 27°C, and container C holds 0.30 mole of He gas at 27°C. The pressure in each of the separate containers can be calculated with $PV = nRT$.

$$P_{\text{O}_2} = \frac{nRT}{V} = \frac{(0.20 \text{ mol}) \cdot (0.08206 \text{ L} \cdot \text{atm} \cdot \text{mol}^{-1} \cdot \text{K}^{-1}) \cdot (300. \text{ K})}{(1.00 \text{ L})} = 4.92 \text{ atm}$$

$$P_{\text{N}_2} = \frac{nRT}{V} = \frac{(0.50 \text{ mol}) \cdot (0.08206 \text{ L} \cdot \text{atm} \cdot \text{mol}^{-1} \cdot \text{K}^{-1}) \cdot (300. \text{ K})}{(1.00 \text{ L})} = 12.3 \text{ atm}$$

$$P_{\text{He}} = \frac{nRT}{V} = \frac{(0.30 \text{ mol}) \cdot (0.08206 \text{ L} \cdot \text{atm} \cdot \text{mol}^{-1} \cdot \text{K}^{-1}) \cdot (300. \text{ K})}{(1.00 \text{ L})} = 7.39 \text{ atm}$$

The sum of these three pressures is 24.6 atm.

If all three gases are placed in one of the containers at 27°C, the pressure in the single container can also be calculated with $PV = nRT$. (Remember that with all three gases in the same container, the number of moles is 0.20 + 0.50 + 0.30 = 1.00 mole.

$$P_{\text{MIXTURE}} = \frac{nRT}{V} = \frac{(1.00 \text{ mol}) \cdot (0.08206 \text{ L} \cdot \text{atm} \cdot \text{mol}^{-1} \cdot \text{K}^{-1}) \cdot (300. \text{ K})}{(1.00 \text{ L})} = 24.6 \text{ atm}$$

You can quickly verify that the total pressure in the single container is the sum of the individual pressures the gases would exert if they were alone in their own container. The pressure exerted by each of the gases in a mixture is called the **partial pressure** of that gas. Hence, Dalton's law is known as the law of partial pressures.

This video presents a discussion of various relationships involved in Dalton's Law of partial pressures (4i): <http://www.youtube.com/watch?v=vPWFjmX-1aI> (6:22).

MEDIA

Click image to the left for more content.

Graham's Law of Diffusion

It was mentioned earlier that gases will spread out and occupy any and all space available. The spreading out and mixing of a substance is called **diffusion**. The small spaces available in liquid structure allow diffusion to occur only slowly. A drop of food coloring in a glass of water (without stirring) might take half an hour or more to spread through the water evenly. With a solid structure we would expect no diffusion or mixing at all, although there are stories of lead and gold bricks stacked together for many years that showed a few molecules have exchanged on the surfaces. Even if the story is true, diffusion in solids is negligible. In comparison, diffusion is very rapid in gases. Not even the presence of other gases offer much obstacle to gases. If someone opens a bottle of perfume or ammonia from across the room, it is only a matter of minutes before you smell it. The molecules evaporate from the liquid in the bottle and spread throughout the room quickly.

It turns out that diffusion is not the same for all gases. If bottles of strong smelling substances are opened at the same time from across the room, the odors will not reach you at the same time. If we pick the strong smelling substances ammonia (NH_3) and acetone ($\text{C}_3\text{H}_6\text{O}$) and opened bottles of these substances, you will always smell the ammonia before the acetone. If we think about this situation a little more, we can probably predict this behavior. Since the two liquids are released in the same room, they are likely to be at the same temperature, so the molecules of both liquids will have the same kinetic energy. Remember that when molecules have the same kinetic energy, the larger molecules move slower and the smaller ones move faster. If we consider the molar mass of these two substances, the molar mass of ammonia is 17 g/mol, and the molar mass of acetone is 58 g/mol. We would have realized, then, that the ammonia molecules are traveling quite a bit faster than the acetone molecules in order for them to have the same kinetic energy. As a result, we would have expected the ammonia to diffuse through the room faster.

A demonstration commonly used to show the different rates of diffusion for gases is to dip one cotton ball in an ammonia solution and another cotton ball in a dilute HCl solution and stuff both cotton balls at opposite ends of a glass tube. This setup is shown in the diagram below. When NH_3 and HCl react, they form NH_4Cl , a white powdery substance. Molecules of NH_3 and HCl will escape the cotton balls at opposite ends of the tube and diffuse through the tube toward each other. Since the molar mass of HCl is slightly more than double that of NH_3 , the NH_3 will travel further down the tube than the HCl by the time they meet.

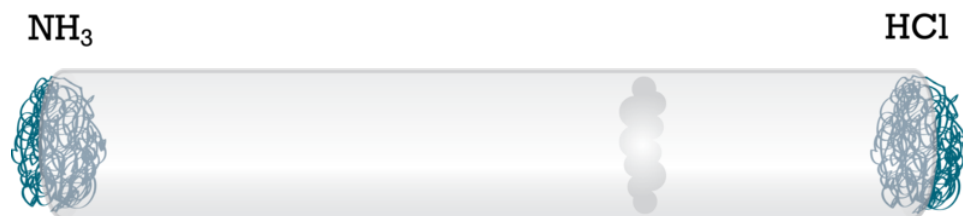

As a result, the white cloud of NH_4Cl always forms closer to the HCl end. If this experiment is done carefully and the distances are measured accurately, a reasonable ratio for the molar masses of these compounds can be determined.

Thomas Graham (1805-1869), an English chemist, studied the rates of diffusion of different gases and was able to describe the relationships quantitatively in what is called **Graham's law**:

Under the same conditions of temperature and pressure, gases diffuse at a rate inversely proportional to the square root of the molecular masses.

Mathematically, this expression would be written as:

$$\frac{V_1}{V_2} = \sqrt{\frac{M_2}{M_1}} \quad (M \text{ is the molecular mass of the particle})$$

The video demonstrates diffusion in gases and liquids. It clearly shows the differences in rate of diffusion due to molar mass as well as higher temperatures (4b): <http://www.youtube.com/watch?v=H7QsDs8ZRMI> (4:57).

**MEDIA**

Click image to the left for more content.

Lesson Summary

- At STP, one mole of any gas occupies 22.4 liters.
- When gases are mixed and do not react chemically, the total pressure of the mixture of gases will be equal to the sum of the partial pressures of the individual gases (Dalton's law of partial pressures).
- Gases diffuse at rates that are inversely proportional to the square roots of their molecular masses (Graham's law).

Further Reading / Supplemental Links

This video shows an experiment that demonstrates the molar volume of a gas at STP is 22.4 liters.

- <http://www.youtube.com/watch?v=4b852VIEkHQ>

Review Questions

1. A 1.00 L container of helium gas at 1.00 atm pressure and a 1.00 L container of hydrogen gas at 2.00 atm are both transferred into a 1.00 L container containing nitrogen gas at 3.00 atm. What is the final pressure in the final container holding all three gases (assuming no temperature change)?
2. For the situation described in problem #1, what will be the partial pressure of the helium in the final container?
3. At STP, how many molecules are in 89.6 liters of gas?
4. If 1.00 liter of gas A at STP and 1.00 liter of gas B at STP are both placed into a 2.00 liter evacuated container at STP, what will the pressure be in the 2.00 liter container?
5. Consider the gases CO and N₂. Which of the following will be nearly identical for the two gases at 25°C and 1.0 atm? i. average molecular speed ii. rate of effusion through a pinhole iii. density
 - a. i only
 - b. iii only
 - c. i and ii only
 - d. ii and iii only
 - e. i, ii, and iii
6. The density of an unknown gas at 2.0 atm and 25°C is determined to be 3.11 g/L. Which of the following gases is the unknown most likely to be?

- a. CH₄
- b. F₂
- c. N₂O₄
- d. O₂
- e. CF₂Cl₂

15.7 Stoichiometry Involving Gases

Lesson Objectives

The student will:

- solve stoichiometry problems involving the conversion of gas volumes at STP to moles and vice versa
- solve stoichiometry problems involving the conversion of gas volumes at STP to gas volumes under non-standard conditions

Introduction

The knowledge of the gas laws and the molar volume of gases at STP allow us to solve stoichiometry problems from gas volumes as well as masses.

Volumes, Moles, and Molecules

Recall that Avogadro's law tells us that under the same conditions of temperature and pressure, equal volumes of gases will contain equal numbers of molecules. By logical extension, we can say that under the same conditions of temperature and pressure, equal numbers of molecules will occupy equal volumes. For example, 1.00 mole of hydrogen gas will occupy the same volume as 1.00 mole of oxygen gas if their temperatures and pressures are the same. With the same logical extension, we can say that at the same temperature and pressure, 2.00 moles of oxygen gas will occupy twice the volume of 1.00 mole of hydrogen gas. This logic allows us an additional way to read chemical equations involving only gases.

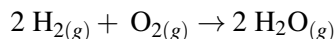

The first way we learned to read this equation was: 2 molecules of hydrogen gas react with 1 molecule of oxygen gas to yield 2 molecules of gaseous water. After we learned about moles, we could also read this equation as: 2 moles of hydrogen gas react with 1 mole of oxygen gas to yield 2 moles of gaseous water. Now, we have a third way to read this all gaseous equation: 2 volumes of hydrogen gas react with 1 volume of oxygen gas to yield 2 volumes of gaseous water, if all substances are at the same temperature and pressure. The reacting ratio indicated by the coefficients in this equation are true for molecules, moles, and volumes for a reaction involving only gases as long as all the gases are under the same conditions.

Example:

What volume of oxygen gas is necessary to react with 100. L of hydrogen gas, assuming all volumes are measured at the same temperature and pressure?

Solution:

The reacting ratio indicated by the coefficients from the equation are true for gas volumes under equal conditions.

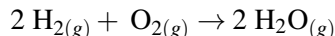

The coefficients of the balanced equation indicate that 2 molecules of hydrogen will require 1 molecule of oxygen to react completely, so 100. L of hydrogen will required 50.0 L of oxygen to react completely.

$$\frac{2 \text{ mol H}_2}{1 \text{ mol O}_2} = \frac{100. \text{ L of H}_2}{x \text{ L of O}_2} \quad \text{so} \quad x = 50.0 \text{ L of O}_2$$

Volume-Volume Calculations at STP

When you first learned to solve stoichiometry problems, one of the steps was to convert known quantities to moles. In those early problems, the known quantity was given in mass and you converted mass to moles by dividing grams by molar mass. From now on, you may be given known quantities of a gas as a volume at either STP or some other temperature and pressure conditions. You already know how to convert a volume of gas at STP to moles. At STP, one mole of any gas occupies 22.4 liters. If you are given a volume of gas at STP as a known, you convert it to moles by dividing by 22.4 L/mol. If you are given a volume of gas at conditions other than STP, you must use $PV = nRT$ to calculate the number of moles.

Example:

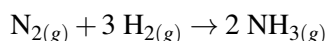

According to this equation, how many liters of ammonia can be formed from 50.0 L of nitrogen gas, N_2 . Assume all gases are at STP.

Solution:

Since both the given substance and the requested substance are gases under the same conditions of temperature and pressure, the reacting ratio indicated by the coefficients in the equation are true for volumes.

$$\frac{1 \text{ N}_2}{2 \text{ NH}_3} = \frac{50.0 \text{ L of N}_2}{x \text{ L of NH}_3} \quad \text{so} \quad x = 100. \text{ L of NH}_3$$

Example:

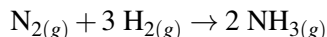

According to this equation, how many grams of ammonia can be formed from 30.0 L of hydrogen gas at STP?

Solution:

Since the hydrogen gas volume is given at STP, we can convert the volume to moles by dividing by 22.4 L/mol. Once we have the given quantity in moles, the remainder of the problem is the same as other stoichiometry problems.

$$(30.0 \text{ L}) \cdot \left(\frac{1.00 \text{ mol}}{22.4 \text{ L}} \right) = 1.34 \text{ mol H}_2$$

$$\frac{3 \text{ H}_2}{2 \text{ NH}_3} = \frac{1.34 \text{ mol H}_2}{x \text{ mol NH}_3} \quad \text{so} \quad x = 0.893 \text{ mol NH}_3$$

$$\text{grams NH}_3 = (\text{moles}) \cdot (\text{molar mass}) = (0.893 \text{ mol}) \cdot (17.0 \text{ g/mol}) = 15.2 \text{ grams}$$

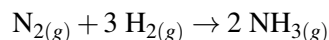
Example:

According to this equation, how many liters of ammonia gas at STP can be formed from 25.0 g of hydrogen gas?

Solution:

The solution steps are to convert the grams of H₂ to moles, use the ratio from the equation to solve for moles of ammonia gas, and then convert the moles of ammonia to liters of gas at STP. The moles of ammonia gas is converted to liters at STP by multiplying by 22.4 L/mol.

$$(25.0 \text{ g}) \cdot \left(\frac{1.00 \text{ mol}}{2.02 \text{ g}} \right) = 12.4 \text{ mol H}_2$$

$$\frac{3 \text{ H}_2}{2 \text{ NH}_3} = \frac{12.4 \text{ mol H}_2}{x \text{ mol NH}_3} \quad \text{so} \quad x = 8.27 \text{ mol NH}_3$$

$$\text{liters NH}_3 = (\text{moles}) \cdot (\text{molar mass}) = (8.27 \text{ mol}) \cdot (22.4 \text{ L/mol}) = 185 \text{ liters}$$

Mole-Volume or Volume-Mole Calculations Not at STP

When volumes involved in chemical reactions are not given at standard conditions, the conversion between moles of gas and volume of gas can be determined by using the universal gas law, $PV = nRT$.

Example:

1,000. grams of calcium carbonate are heated and react according to the following equation:

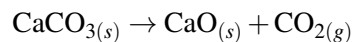

If the carbon dioxide is collected at 500. K and 2.00 atm, what volume will it occupy under these conditions?

Solution:

$$(1000. \text{ g}) \cdot \left(\frac{1.00 \text{ mol}}{100. \text{ g}} \right) = 10.0 \text{ mol CaCO}_3$$

Since the reacting ratio between calcium carbonate and carbon dioxide in the equation is 1 to 1, the 10.0 mol of calcium carbonate will form 10.0 mol of carbon dioxide. We use $PV = nRT$ to find the volume that 10.0 mol of gas will occupy under these conditions.

$$V = \frac{nRT}{P} = \frac{(10.0 \text{ mol}) \cdot (0.08206 \text{ L} \cdot \text{atm} \cdot \text{mol}^{-1} \cdot \text{K}^{-1}) \cdot (500. \text{ K})}{(2.00 \text{ atm})} = 205 \text{ liters}$$

Lesson Summary

- In a balanced gaseous equation, the coefficients apply to molecules, moles, and volumes of gas if the gases are under the same conditions of temperature and pressure.

Review Questions

1. How many liters of hydrogen gas are required to react with 25.0 L of nitrogen gas according to the following equation: $\text{N}_{2(g)} + 3 \text{H}_{2(g)} \rightarrow 2 \text{NH}_{3(g)}$?
2. How many grams of ammonia will be formed from 25.0 L of nitrogen gas measured at STP according to the equation in problem #2?

All images, unless otherwise stated, are created by the CK-12 Foundation and are under the Creative Commons license CC-BY-NC-SA.

CHAPTER 16 Condensed Phases: Solids and Liquids

Chapter Outline

- 16.1 PROPERTIES OF SOLIDS AND LIQUIDS
 - 16.2 INTERMOLECULAR FORCES OF ATTRACTION
 - 16.3 IONIC, METALLIC, AND NETWORK CONDENSED PHASES
 - 16.4 VAPOR PRESSURE AND BOILING
 - 16.5 HEAT AND CHANGES OF STATE
 - 16.6 PHASE DIAGRAMS
 - 16.7 REFERENCES
-

16.1 Properties of Solids and Liquids

Lesson Objectives

The student will:

- describe the molecular arrangement of solids and liquids.
- explain the incompressibility of solids and liquids.
- explain the low rate of diffusion in solids and liquids.
- explain the ability of solids to maintain their shape and volume.
- explain the ability of liquids to maintain their volume and inability to maintain their shape.

Vocabulary

- incompressible

Introduction

Liquids and solids differ from gases in that the particles (atoms, molecules, or ions) are much closer together, so the total volume of a liquid or solid is much closer to the sum of the volumes of the particles. The volume of a gas, as you may recall from the chapter on “The Behavior of Gases,” is related to the volume of the spaces between the particles and not to the volume of the particles.

At all temperatures above absolute zero, atoms and molecules are in constant random motion. The particles travel in a straight line unless they collide with another particle. In the absence of any attractive forces, this molecular motion would cause all substances to be in gaseous form. The fact that solid and liquid states exist tells us that there are forces that hold molecules and atoms together even when they are not chemically bonded. The forces of attraction that hold atoms and molecules together in solid and liquid phases are called intermolecular forces of attraction. These forces are different from chemical bonds, which are called intramolecular forces.

The phase (solid, liquid, or gas) of a substance is the result of a competition between the molecular motion that pushes the molecules apart and the attractive forces that pull them together. If the molecular motion is much greater than the attractive forces, the substance will be gaseous. If the molecular motion is nearly the same in strength as the attractive forces, the substance will be liquid, and if the molecular motion is much less than the attractive forces, the substance will be solid. When the molecular motion is increased or decreased by changing the temperature, the relationship between the molecular motion and the attractive forces changes, and the substance may change its phase.

The Structure of Solids and Liquids

The diagram below illustrates the molecular arrangements in the three phases of matter.

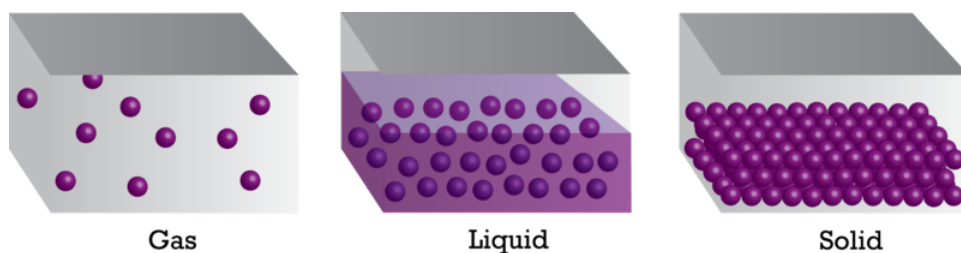

In the gaseous phase, the molecular motion dominates. The molecules of the substance are completely separated and move about independently of each other. The spaces between the molecules are very large compared to the size of the particles, so the measured volume of a gas is actually a measurement of the spaces between the molecules. In comparison, the molecular structure of the liquid phase has some spaces between the particles that allow the particles to move past one another, but the attraction between the particles is strong enough to prevent them from moving very far apart. In the solid phase, the forces of attraction have completely overcome molecular motion, and the movement of the particles has been reduced to vibrating in place. The particles cannot move past one another and are held in a tightly-packed pattern, so there is very little space between the particles.

For a brief animation showing the differences in molecular motion and relative position for gases, liquids, and solids (2d), see <http://www.youtube.com/watch?v=s-KvoVzukHo> (0:52).

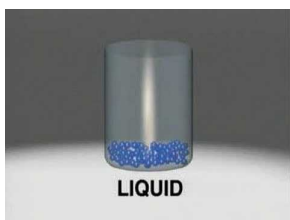

MEDIA

Click image to the left for more content.

For a video demonstration of a physical model of molecular motion and states of matter (2d), see <http://www.youtube.com/watch?v=ynUso6rJ0rE> (3:02).

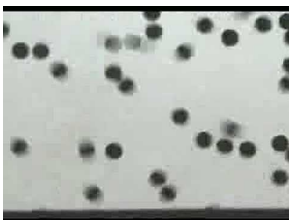

MEDIA

Click image to the left for more content.

Properties of Solids

The intermolecular forces of attraction in solids hold the particles so tightly in place that they cannot pull away from each other to expand their volume, nor can they flow past one another to change shape. Therefore, solids hold their own shape and volume regardless of their container. There is very little empty space in the solid structure, so

solids are virtually **incompressible**. Since molecules cannot pass each other in the structure, diffusion or mixing is essentially non-existent beyond the surface layer.

Properties of Liquids

Attractive forces between molecules are a major factor in the behavior of the liquids. Since the particles in a liquid remain in touch with each other, liquids maintain their volume, but since the particles can flow past each other, liquids take the shape of their container. 100 mL of liquid will be 100 mL in any container, but because the liquid molecules are not held in a tightly-packed pattern like solids are, the molecules can move past one another, allowing the liquid to fit the shape of the container.

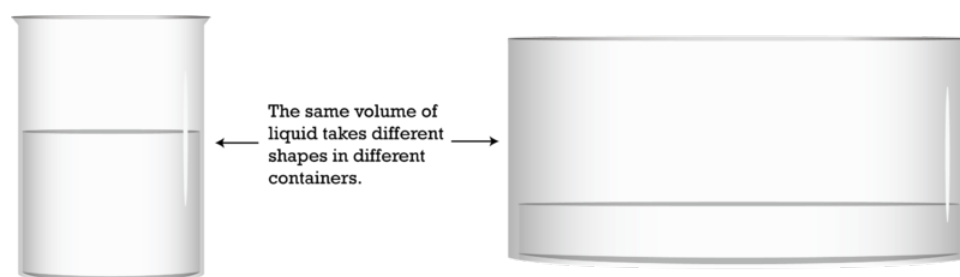

In gases, the distance between the molecules is so great that the size of the molecules themselves become inconsequential. A gas, then, is considered to be essentially empty space. If we consider the volumes of 6.02×10^{23} molecules of oxygen gas, O_2 , and 6.02×10^{23} molecules of Freon gas, CF_4 , at STP, we know that the volumes will be the same, 22.4 liters. This is because the sizes of the molecules themselves are negligible compared to the empty space in a gas. The fact that the Freon molecules are several times larger than the oxygen molecules makes no difference. In a gas, you are measuring the volume of the empty space. If we consider the volume of 6.02×10^{23} molecules of liquid oxygen and 6.02×10^{23} molecules of liquid Freon both at STP, we find the volume of the oxygen is about 28 mL and the volume of the Freon is about 55 mL. In the case of liquids, the volumes of the molecules themselves make a difference. In liquids, the volume of a group of molecules is related to the volume of the individual molecules, so equal moles of liquids *do not* occupy equal volumes under the same conditions. Since liquids have many more molecules in a smaller volume, they will have much greater densities than gases.

When a substance is compressed, it is not the molecules themselves that are compressed; it is the space between the molecules that is compressed. Gases have a great deal of empty space and are easily compressed. A pressure of 3.0 atm compresses a gas to one-third its volume at 1.0 atm. Liquids have very little space between molecules and do not compress easily – a pressure of 3.0 atm will have virtually no effect on the volume of a liquid. Liquids are used in hydraulic systems because of their ability to flow to fit their container and their incompressibility.

Diffusion in gases (mixing) is nearly instantaneous. If you release a colored gas in a container of non-colored gas, the color spreads evenly throughout the container in a second or two. In liquids, diffusion is a much slower process. The dye molecules require much more time to move from one side of a container to the other due to the smaller spaces between molecules and the almost constant collisions with other molecules.

Lesson Summary

- The molecular arrangement in solids is a highly organized, tightly-packed pattern with small spaces and molecular motion reduced to vibration in place.
- Molecules in a solid maintain both their own shape and their own volume.

- Solids are virtually incompressible and have little diffusion beyond the surface layer.
- Molecules in the liquid phase have some freedom of movement but their motion is much more restricted than that of gases.
- Liquids maintain their volume but take the shape of their container.
- Liquids are only slightly compressible.
- Diffusion in liquids occurs more slowly than in gases.

Further Reading / Supplemental Links

An interactive animated video showing the motion and arrangement of molecules in the three states of matter.

- http://www.harcourtschool.com/activity/states_of_matter/

This video shows demonstrations that demonstrate the states of matter.

- <http://www.youtube.com/watch?v=j2KZmRIKea8&feature=related>

Review Questions

1. The molar volumes of solid silicon and solid bromine under the same conditions are different and the molar volumes of liquid silicon and liquid bromine under the same conditions are different, but the molar volumes of gaseous silicon and gaseous bromine under the same conditions are exactly the same. Explain.

16.2 Intermolecular Forces of Attraction

Lesson Objectives

The student will:

- explain the difference between intermolecular and intramolecular forces of attraction.
- name and describe the types of intramolecular forces that hold groups of molecules together.
- explain how dipole-dipole forces differ from hydrogen bonds and London dispersion forces.
- identify liquids whose intermolecular forces of attraction are due to London dispersion forces, polar attractions, and hydrogen bonding given the formulas, structural data, and phase change points.
- describe some of the unique properties of water that are due to hydrogen bonding.

Vocabulary

- hydrogen bond
- London dispersion forces

Introduction

Attractive forces on the molecular level are divided into two categories – the forces inside a molecule holding atoms together, and the forces between molecules holding molecules together. In the image below, the forces holding the oxygen and hydrogen atoms together are the intramolecular forces. Intramolecular forces are the forces inside the molecule and consist of ionic and covalent bonds. The forces that hold the H_2O molecules together as either liquid water or ice are the intermolecular forces. Intermolecular forces are the forces between molecules and are responsible for holding molecules in the solid or liquid state when no covalent or ionic bonds are possible. You can relate these two types of forces to bus systems where intra-city buses move people around inside one city and inter-city buses move people from one city to another.

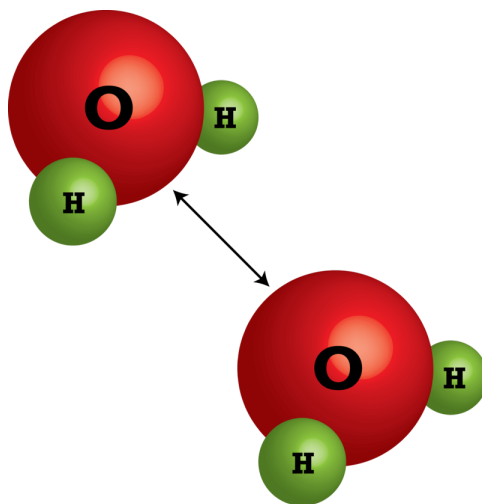

When a substance in the solid phase is heated sufficiently, the molecular motions increase to the point that they overcome the forces holding the solid together, so the solid melts to liquid form. If the liquid is then heated sufficiently, the molecular motion increases to the point that it completely overcomes the attractive forces, so the liquid will change to the gaseous phase. The reverse of this process occurs when the substance is cooled. The conversion of solid to liquid, liquid to gas, gas to liquid, and liquid to solid are called phase changes.

The intermolecular forces must be overcome during a phase change. Therefore, the stronger the intermolecular forces of attraction, the greater the molecular motion (temperature) required to overcome them. The solids and liquids with the strongest intermolecular forces of attraction will have the highest melting and boiling points, and vice versa. The phase change temperatures for the various types of solids and liquids cover a very wide range. Substances with very weak forces, like helium, will melt at only a couple of degrees above absolute zero, whereas solid substances like asbestos and diamond do not melt until the temperature is in excess of 3500°C.

London Dispersion Forces

The weakest type of intermolecular force is called London dispersion forces. **London dispersion forces** occur between all atoms and molecules, but they are so weak, they are only considered when there is no other intermolecular forces. For example, London dispersion forces exist between water molecules, but water molecules also have a permanent polar attraction so much stronger than the London dispersion forces that the London dispersion force is insignificant and not mentioned.

The cause of London dispersion forces is not obvious. Although we usually assume that the electrons of an atom are uniformly distributed around the nucleus, this is not true at every instance. As the electrons move around the nucleus, at a given instance, more electrons may be on one side of the nucleus than the other. This momentary nonsymmetrical electron distribution can produce a temporary dipolar arrangement of charge. This temporary dipole can induce a similar dipole in a neighboring atom and produce a weak, short-lived attraction.

The cases where London dispersion forces would be considered as the only intermolecular force of attraction would be for the noble gases and non-polar molecules such as helium, neon, argon, krypton, xenon, hydrogen, oxygen, methane, carbon dioxide, and so forth. Since non-polar molecules do not have a permanent dipole and no further bonding capacity, their only means of attracting each other is through London dispersion forces. Some of the substances whose intermolecular forces of attraction are London dispersion forces are held in the liquid state so weakly, they have the lowest melting points of all substances (see **Table 16.1** for examples).

TABLE 16.1: Boiling Points of Some London Dispersion Forces Liquids

Substance	Chemical Symbol	Boiling Point, °C
Helium	He	-269.7
Neon	Ne	-248.6
Argon	Ar	-189.4
Krypton	Kr	-157.3
Xenon	Xe	-111.9
Hydrogen	H ₂	-253
Oxygen	O ₂	-182
Methane	CH ₄	-161
Carbon Dioxide	CO ₂	-78

The temporary dipoles that cause London dispersion forces are affected by the molar mass of the particle. The greater the molar mass of the particle, the greater the force of attraction caused by London dispersion forces. The molar masses of H₂, N₂, and O₂ are 2, 28, and 32 g/mol, respectively, and their boiling points increase in similar fashion; -253°C for H₂, -196°C for N₂, and -183°C for O₂. For molecules with a high molecular weight, the London dispersion forces become strong enough that the substance will be a liquid or solid even at room temperature. Carbon tetrachloride, molar mass 154 g/mol, and bromine, molar mass 160 g/mol, boil at +77°C and +59°C, respectively. Many long carbon chain, non-polar substances such as gasoline and oil remain liquids at common temperatures.

Dipole-Dipole Interactions

When covalent bonds form between identical atoms, such as in H₂, N₂, O₂, and so on, the electrons shared in the bonds are shared equally. The two atoms have the same electronegativity and therefore the same pull on the shared electrons (as illustrated in the figure below).

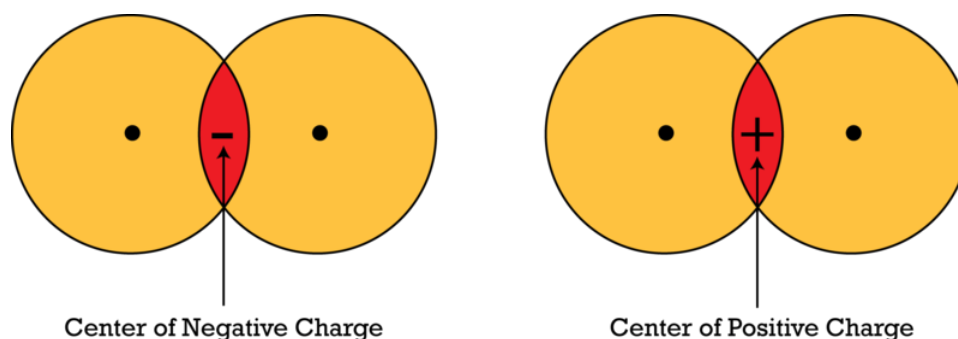

The center of negative charge for the entire molecule will be in the exact center of the molecule. This will coincide with the center of positive charge for the molecule. When the center of negative charge and the center of positive charge coincide, there is no charge separation and no dipole.

In the case of a symmetrical molecule with polar bonds, like the one shown below, the symmetry of the electron displacements will also keep the center of negative charge in the center of the molecule, which coincides with the center of positive charge. As a result, no dipole will occur.

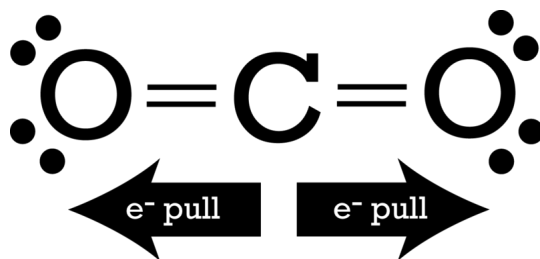

If the two atoms sharing the bonding pair of electrons are not of the same element, the atom with the greater electronegativity will pull the shared electrons closer to it. Because of the resulting uneven distribution of electrons, the center of negative charge will not coincide with the center of positive charge and a dipole is created on the molecule. When the centers of positive and negative charge do not coincide, a charge separation exists and a dipole is present. For example, in the CO_2 molecule above, both carbon-oxygen bonds are polar and the bonding electrons are shifted toward the oxygen.

The end of the molecule with the more electronegative atom will have a partial negative charge, and the end of the molecule with the more electropositive atom will have a slight positive charge. The symbols δ^+ and δ^- , as illustrated in the figure below, are used because these are not full positive and negative charges.

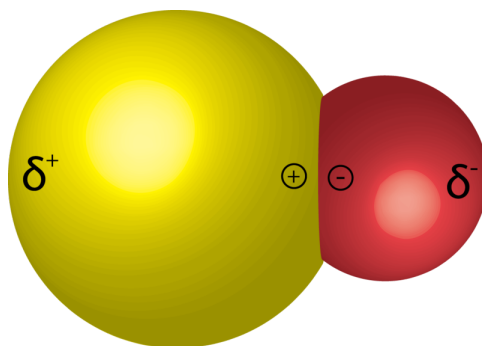

This polarity is much less than the charge separation in an ionic bond. These charges are only fractions of the full “+1” and “-1” charges. How much polarity a bond will experience depends on the difference in the electronegativities of the atoms.

For molecules that have a permanent dipole, the attraction between oppositely charged ends of adjacent molecules are the dominant intermolecular force of attraction. The figure below represents a polar solid; a polar liquid would look similar except the molecules would be less organized. On average, these polar attractions are stronger than London dispersion forces, so polar molecules in general have higher boiling points than London dispersion liquids. There is significant overlap, however, between the boiling points of the stronger London dispersion molecules and the weaker polar molecules.

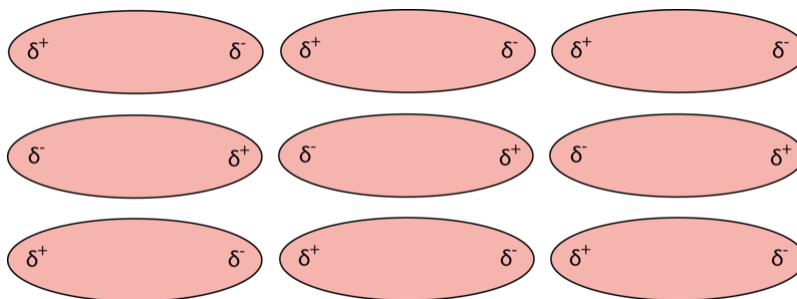

The organization of a substance composed of polar molecules depends on the competition between the strength of the polar attractions and the molecular motion of the molecules. At higher temperatures, the molecular motion of the

molecules is strong enough to disrupt the polar attractions, but at low temperatures, the molecular motion is reduced so that the polar attractions can hold the molecules in a structured arrangement.

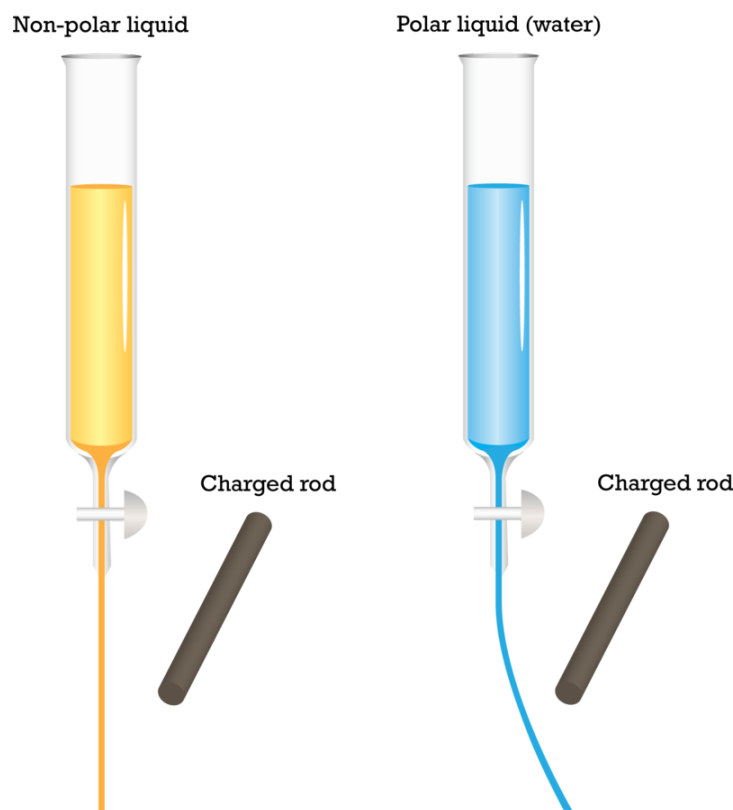

In liquid and gaseous forms, the molecules can also turn freely. This turning of polar molecules can be seen in a macroscopic situation. If we bring a charged object (rubber comb run through hair, balloon rubbed on wool sweater, etc) near a very thin stream of water running from a faucet, the stream will bend its path toward the charged object. It doesn't make any difference if the charged object is positively or negatively charged because the water molecules in the stream will turn their oppositely charged ends toward the charged object. In the sketch above, you can see that the path of a non-polar liquid is not deflected by the charged rod, but the path of the water stream is deflected by the charged rod.

Hydrogen Bonds

There are several polar molecules whose polar bonds are so strong they merit separate attention. These are the polar attractions that occur in molecules where hydrogen is bonded to nitrogen, oxygen, or fluorine. The polar attractions in these molecules are nearly 10 times as strong as regular polar attractions. These extra strong polar attractions that occur with H – N, H – O, and H – F bonds are called **hydrogen bonds**, which distinguishes them from regular polar attractions. Keep in mind, however, that they are still polar attractions, albeit very strong ones.

There is more than one explanation for why these three combinations form hydrogen bonds. There are only ten elements that have greater electronegativity than hydrogen, and only four that have a significantly greater electronegativity than hydrogen. Three of the elements that have significantly greater electronegativity than hydrogen are nitrogen, oxygen, and fluorine – the three elements that form hydrogen bonds in compounds with hydrogen. When hydrogen bonds with atoms whose electronegativities are less than or equal to the electronegativity of hydrogen, the other atom cannot pull the shared electrons away from hydrogen, as seen in the figure below.

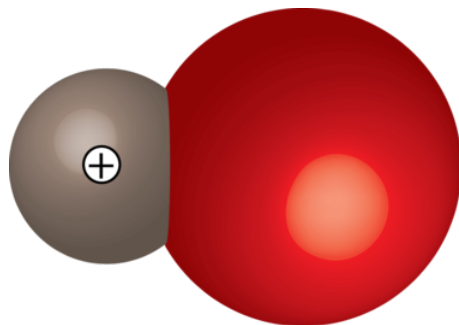

In HBr, the bonding electrons remain partially around the hydrogen nucleus and shield its nucleus.

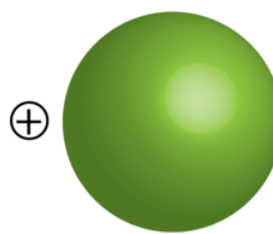

In HF, the bonding electrons are pulled away leaving an unshielded nucleus.

When hydrogen chemically bonds with nitrogen, oxygen, or fluorine, the very high electronegativities of these atoms can pull the electrons far away from the hydrogen atom, thus removing the shielding electrons from the proton nucleus of hydrogen. As a result, when the polar attractions between hydrogen bonding compounds form, the negative end of a molecule can get very close to the proton on the positive end of another molecule because there are no electrons for shielding. The closeness of the charges causes the extra strong polar attractions in these compounds. The characteristics of a liquid that forms hydrogen bonds are significantly different from similar compounds that do not form hydrogen bonds.

A homologous series of compounds are compounds where the elements of a family are each bonded to the same element. For example, family 4A in the periodic table consists of carbon, silicon, germanium, and tin. If each of these is bonded to hydrogen, it would produce a homologous series, CH_4 , SiH_4 , GeH_4 , and SnH_4 . If we graph the boiling points of this homologous series, we would get the graph sketched on the left side in the figure below. A large majority of the graphs plotting the boiling points of a homologous series would look like the one below, where the boiling points increase as molar mass increases.

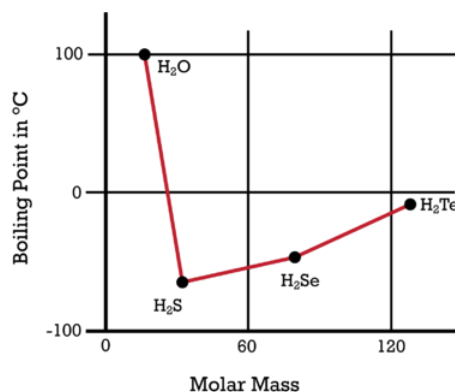
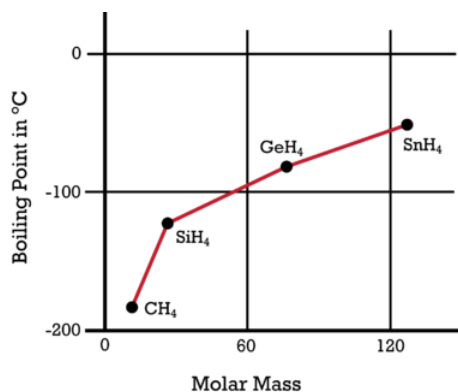

However, if we graph the boiling points of the homologous series of family 6A combined with hydrogen, we get quite a different graph, as seen on the right side of the sketch. The higher molar mass compounds in the series follow the normal pattern where the boiling points decrease as the molar masses decrease. When we get to water, the boiling point suddenly increases – it is more than 150° higher. Hydrogen bonding explains why liquid water is held together far more tightly than expected. Graphs of the boiling points for the homologous series of hydrogen with 5A family members and hydrogen with 7A family members would be similar, with the boiling points of NH_3 and HF being greatly different from what would be expected.

Significant hydrogen bonding causes water molecules to line up end-to-end. The fact that water forms hydrogen bonds has effects so large that it is impossible in this text to delineate them all. We will consider just a few of these effects here.

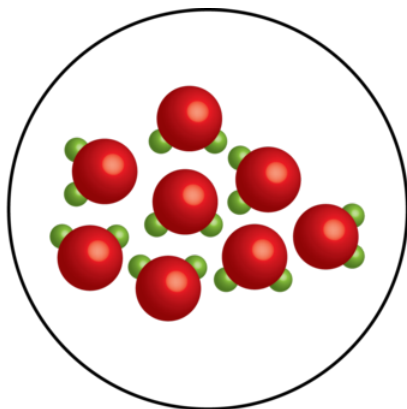

Water with no significant hydrogen bonding.

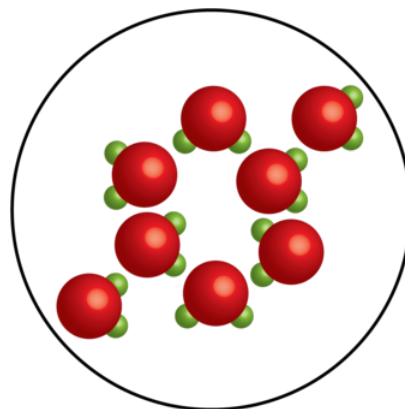

Water with significant hydrogen bonding.

1. The normal boiling point of water is 100°C . If water did not form hydrogen bonds and had a regular polar attraction between molecules, its boiling point would be somewhere around -60°C . The average temperature of the Earth's surface is -15°C , so if water did not form hydrogen bonds, the oceans and lakes would vaporize. Therefore, Earth would not be a watery planet and would not likely be a planet with life on it.

2. For almost all substances, the substance contracts as it cools – the molecules move around slower, and the intermolecular forces pull the molecules closer together. As a result, the solids are denser than the liquids, and the solids will sink in the liquids. Water, of course, is the exception. When water cools to its freezing point and solidifies, it expands. The molecular motion for water molecules at or above 4°C is sufficient to keep the water molecules in a molecular complex with large holes in the structure. When water is cooled below 4°C , the molecular motion is inadequate to break up this complex structure, and the water molecules expand because of the holes in the structure. Therefore, solid water is less dense than liquid water, and ice floats on water.

One of the consequences of this effect is that when cold weather comes to areas in the northern and southern parts of the earth, the cold air freezes the surface water it comes into contact with. If water were like other substances, then the solid would sink to the bottom. The solid would continuously sink to the bottom as the cold air continues to freeze the new surface until the entire lake would be frozen from top to bottom. No water dwelling animals would be able to survive such an occurrence. In reality, however, when the cold air freezes the surface of a lake, the ice floats, stays on top, and insulates the rest of the water from the cold air. Only the surface freezes, allowing the animals that live in the water to survive the winter.

3. One factor that affects the weathering of rocks in some geographical areas is that rain water can cause rocks to fracture. When it rains, water can enter the cracks in rocks. During the winter, the water can freeze and expand, causing the rocks to fracture.

4. Some biologically active molecules, such as DNA, require a particular shape for their function. At points along its length, such a molecule can be linked to itself with different types of attractions – one of which are hydrogen bonds, as seen in the figure below.

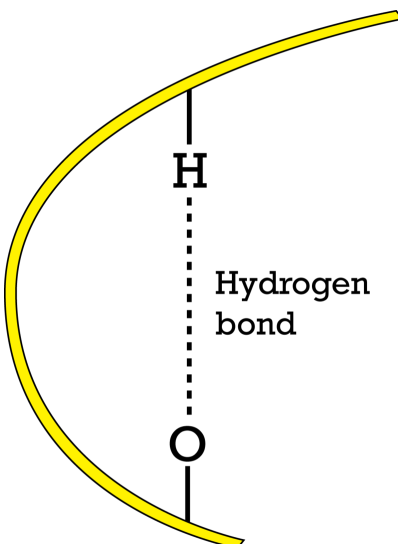

5. As long as water is above 4°C , it contracts and becomes denser upon cooling, just like other substances. At temperatures less than 4°C , significant hydrogen bonding begins to form, causing water to expand and become less dense. The maximum density for water is at 4°C .

Many animals that live in water and require oxygen use oxygen that is dissolved in the water. For deep lakes, diffusion is inadequate to move the oxygenated water to the bottom of the lake. Instead, water in lakes becomes oxygenated (has dissolved oxygen) by the action of wind and waves at the surface. For lakes in northern climates, the surface passes through the temperature 4°C twice a year, once as it cools in the fall and once as it warms in the spring. During these two times, the oxygenated water at the surface would sink to the bottom because it is denser. These periods are called spring and fall “turnovers.” The turnovers provide oxygenated water at the bottom of the lakes.

This video shows and narrates by hydrogen bonds form and shows variations in boiling point of a homologous series due to hydrogen bonding (2h): <http://www.youtube.com/watch?v=LGwyBeuVjhU> (1:40).

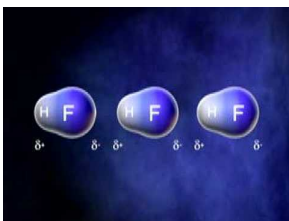

MEDIA

Click image to the left for more content.

Lesson Summary

- Molecules are held together in the liquid phase by intermolecular forces of attractions.
- London dispersion forces are a very weak intermolecular force of attraction caused by a temporary electrostatic attraction between the electrons of one molecule or atom and the nucleus of another.
- Polar attractions are a type of intermolecular force of attraction caused by the electrostatic attraction between permanent dipoles that exists on polar molecules.
- Hydrogen bonds are an exceptionally strong type of polar attraction that occurs between molecules that have H – F bonds, H – O bonds, or H – N bonds.
- Hydrogen bonds are responsible for the unique characteristics of water.

Further Reading / Supplemental Links

The video below examines the various intermolecular and intramolecular forces of attraction.

- <http://www.youtube.com/watch?v=GnswLP4t6d0>

Review Questions

1. Identify the most important type of inter-particle force present in the following solids that is responsible for binding the particles into a solid.
 - a. He
 - b. NO
 - c. HF
 - d. CH₄
 - e. CO₂
 - f. CHCl₃
2. Predict which substance in the following pairs would have the stronger force of attraction between molecules and justify your answer.
 - a. CO₂ or OCS
 - b. PF₃ or PF₅
 - c. H₂O or H₂S

16.3 Ionic, Metallic, and Network Condensed Phases

Lesson Objectives

The student will:

- describe the forces holding molecules together in ionic compounds, metallic solids, and network solids.
- describe the metallic bond and explain some of the characteristics that are due to metallic bonding.
- describe ionic or network solid structures and explain some of the characteristics due to this type of solid bonding.
- identify the type of solid given the characteristics of a solid, such as conductivity of solid and liquid phase, solubility in water, and malleability.

Vocabulary

- alloy
- conductor
- metallic bond

Introduction

The intermolecular forces of attraction include London dispersion forces, dipole-dipole interactions, and hydrogen bonding. These forces can be found to varying degrees in all phases of matter. Depending on the strength of the forces and the temperature of the molecules, these forces affect the properties of the matter. For example, solids held together only by London dispersion forces are poor conductors of electricity and are not malleable. These forces also play a large role in solubility. The general rule is “like dissolves like.” This means that polar solvents will dissolve polar or ionic substances, but not non-polar substances. Non-polar solutes, however, can be readily dissolved in non-polar solvents.

Ionic Solids and Liquids

Ionic solids are held together by the electrostatic attraction between oppositely charged ions. The ions are formed into various types of crystal lattice structures depending on the comparative sizes of the ions and the charges on each. These ionic charges are full charges (+1, +2, -1, -2 and so on), so they are considerably stronger than either polar attractions or hydrogen bonds. This will cause the melting points for ionic substances to be quite high compared to the substances we have been considering. For example, the melting point of sodium chloride, NaCl, is 801°C, and the melting point of calcium sulfate, CaSO₄, is 1460°C.

In solid state, the ions in ionic solids are held firmly in position. There is no space large enough for the ions to move through, even if they could escape the forces of attraction. Since the ions cannot move, ionic solids are non-conductors of electricity. When the solid is melted to a liquid, however, the ions are free to migrate. Therefore, ionic liquids are good conductors of electric current. A **conductor** is a substance capable of transmitting electricity and/or heat. Ionic solids are usually quite soluble in water, and the water solutions of ionic solids are good conductors of electricity because of the freedom of the ions to migrate through the solution.

Metallic Solids

Of the 81 elements which can be clearly classified as metals, all of them except mercury are solids at room temperature. Any model that explains the bonding in metallic solids must account for the properties of metals. Metals typically 1) are excellent conductors of heat and electricity in both solid and liquid phase, 2) are malleable, 3) are white and shiny, 4) are not soluble in any common solvent, polar or non-polar, and 5) have a wide-range of melting points that are mostly higher than the melting points of polar solids.

The simplest proposed model that explains metallic behavior is the **metallic bond**, where a regular pattern of cations is surrounded by a “sea of electrons.” The metal ions occupy positions in a lattice structure while the mobile, free-moving sea of valence electrons occupy all of the overlapping valence shell area, as illustrated in the figure below. The metallic bond consists of non-directed bonds in which a “sea of electrons” surrounds all the bonded atoms. All the atoms are bonded in a single bond that includes the entire piece of metal.

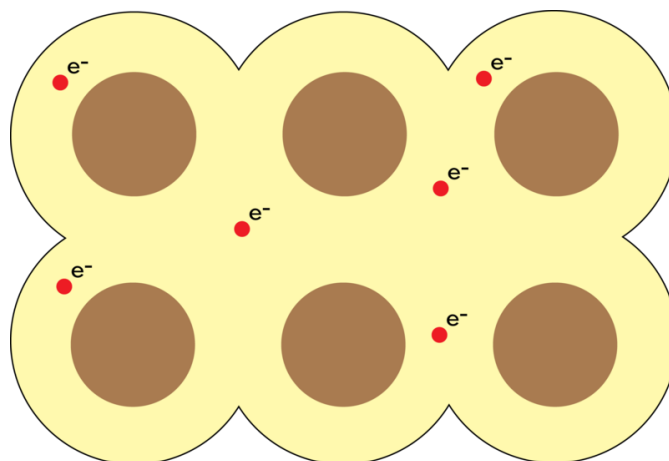

For an animation showing the form of a metallic bond, (2a) see <http://www.youtube.com/watch?v=ijw8OBt4btM> (1:54).

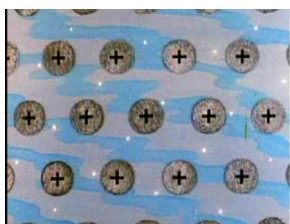

MEDIA

Click image to the left for more content.

For purposes of comparison, consider the covalent bonding in the trigonal planar molecule shown below. The central atom in this molecule contains three pairs of electrons. The electrons take positions as far away from each other as possible due to electrostatic repulsion. Therefore, the pairs of electrons maintain positions at angles of 120° from each other. The atoms that share these electron pairs in the covalent bond must be placed so that the shared electrons

are in the overlapped orbitals of both atoms. Therefore, these bonded atoms may not move with respect to each other. The atoms hold their relative positions because of the directional bonds. Neither the bonding electrons nor the atoms are free to move with respect to each others.

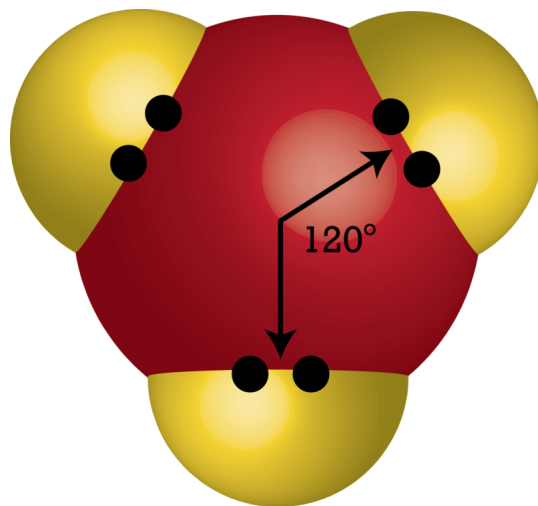

The model of the metallic bond, however, provides for mobile electrons that are free to move throughout the entire piece of metal, thus providing the means for the metal to be an excellent conductor of heat and electricity. Extra electrons pushed onto one side of the metal can easily move to the other side through the valence electron shells. The metal ions are not directionally bounded to their immediate neighbors, which allows them to be pushed to new positions without causing the bond to break. As long as an atom or ion is not separated from the piece of metal, its position can be significantly changed while remaining bounded to the other atoms. This malleability allows metal cubes to be pounded into flat sheets without breaking the bond.

The freedom of the electrons on the surface of a piece of metal also allows the metal to absorb and emit many frequencies of light, which accounts for the white, shiny appearance of many metals. The metals on the far left of the periodic table have the fewest electrons in the valence shells. As a result, the valence electrons in these metals would be least crowded, have the most freedom, and present the most complete metal character. The metals of families IA and IIA are excellent conductors, exceptionally malleable (soft enough to be cut with a spoon), and white and shiny in color.

Other elements can be introduced into a metallic crystal relatively easily to produce substances known as alloys. An **alloy** is a substance that contains a mixture of elements and has metallic properties. A fairly well-known alloy is brass, which is an alloy composed of approximately two-thirds copper atoms and one-third zinc atoms. Sterling silver is an alloy composed of about 93% silver and 7% copper. Iron is a metal that is commonly alloyed with carbon to produce steel. Carbon forms directional bonds with some of the iron atoms to make steel less malleable than pure iron. Steel with less than 0.2% carbon remains somewhat malleable and is used for nails and cables. In comparison, steel with around 0.6% carbon is harder and is used for railroad rails and structural steel beams, while steel with around 1.5% carbon is very hard and is used for tools and cutlery.

Network Solids

In some solids, all the atoms in the entire structure are bounded with covalent chemical bonds. These solids are a single giant molecule and are called network solids. When considering the strength of the various bonds and attractions that hold particles together in the solid state, the strongest is the covalent bond. Therefore, network solids have the highest melting points of all solids, as melting a network solid requires enough molecular motion to disrupt

the covalent bonds. Network solids are not soluble in any common solvent. Some examples of network solids are graphite, diamond, mica, and asbestos. The structures of graphite and diamond are shown below.

Graphite: a two-dimensional network solid

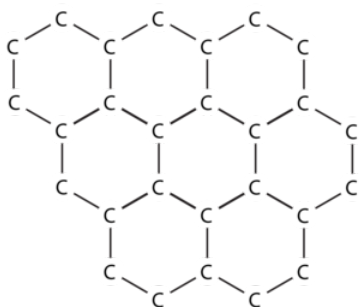

Diamond: a three-dimensional network solid

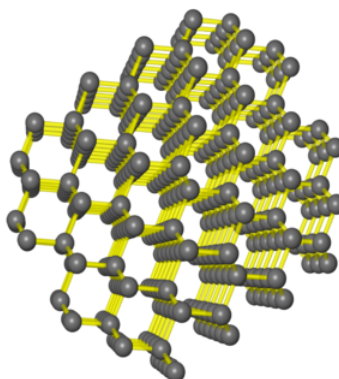

Most network solids are non-conductors, although graphite is an exception and is a good conductor of electricity. The solid structure in graphite involves large, two-dimensional molecules of covalently bonded carbon atoms. The carbon atoms form flat sheets (like a sheet of paper) bounded in the fashion shown above. Layers of these sheets are laid on top of each other, and the sheets are held together by much weaker London dispersion forces. The sheets are extremely strong in the two dimensions bounded with covalent bonds, but the forces holding the sheets together are weak and easily broken. The flat sheets slide over each other readily, making graphite a good lubricant for metal parts.

The mineral mica is also bounded in this two-dimensional network style. Mica is found in nature and appears as a rock, but you can slide your fingernail between sheets and pull off large flat sheets of the rock. One type of mica, called muscovite mica, is transparent enough that you can see through several sheets. This material has been used to make small windows in furnaces that are transparent but won't melt.

Diamonds are giant molecules of carbon atoms bounded three-dimensionally in tetrahedral units. Every carbon atom in the structure is covalently bounded to four other carbon atoms. Diamonds are the hardest substance known and have one of the highest melting points of all substances.

Some forms of asbestos are one-dimensional network solids in which the atoms are bounded in a chain. The result is a fibrous molecule that can be woven into fabric (see example in **Figure 16.1**). Due to its high melting point, asbestos fabric was used to make heat resistant materials (for example, fireman's gloves, furnace padding, clutch plates) for many years until it was determined that asbestos fibers are hazardous if inhaled.

**FIGURE 16.1**

Asbestos in the form of chrysotile. You can see fibers of asbestos in the upper left hand corner of the photo.

The following web site has data and explanatory reasons for the trends in melting and boiling points of some period 3 elements. <http://www.creative-chemistry.org.uk/alevel/module1/trends8.htm>

Amorphous Solids

Many important solids do not have the regular, repeating arrangement of atoms or molecules present in crystalline solids. Solids with irregular, unpredictable molecular organization are called amorphous solids. There are many solids that can form either crystalline or amorphous solids, depending on how rapidly the liquid is cooled. Very rapid cooling frequently results in an amorphous solid, whereas slow cooling produces crystalline solids. Amorphous solids have been described as appearing to have their molecules frozen in place before they have time to settle into an organized pattern. Examples of amorphous solids are glass, paper, plastics, cement, and rubber.

Amorphous solids are called solids because they maintain their shape and volume. Some researchers insist that certain amorphous solids will flow under pressure, which is a characteristic of liquids. Some antique windows have been found to be thicker at the bottom than at the top. Some chemists claim this is because the glass flowed downward very slowly over a hundred years due to the force of gravity. Other chemists claim that these antique glasses are of different thicknesses due to flaws in the glass making process of a hundred years ago, although this opinion doesn't explain why the thicker part of the glass was always at the bottom and never at the top.

Crystalline solids melt at sharply defined temperatures. In comparison, glass and some other amorphous solids only soften as they are heated. As a result, some authors refer to amorphous solids as "not true solids," others call them "super-cooled liquids," and still others insist that amorphous solids are absolutely solids.

Lesson Summary

- Ionic solids are a type of solid in which the intermolecular forces of attraction is the electrostatic attractions due to the opposite charges of the ions.
- In one type of solid formed by metallic atoms, a sea of electrons exerts a force of attraction on the positive ions (metallic bond).
- Network solids have every atom in the structure attached to other atoms in the structure by covalent chemical bonds.
- Amorphous solids are solids that cooled so rapidly, the molecules did not get into the tight, organized solid pattern. Due to their disorganized structure, amorphous solids have some properties more like liquids.

Further Reading / Supplemental Links

The *learner.org* website allows users to view streaming videos of the Annenberg series of chemistry videos. You are required to register before you can watch the videos, but there is no charge to register. The website has a video that apply to this lesson called "Metals" that details the value of accuracy and precision. In the video, malleability, ductility, and conductivity are examined, along with the methods for extracting metals from ores and blending alloys.

- http://learner.org/vod/vod_window.html?pid=811

The following sites provide more information about crystals, glasses, and amorphous materials.

- <http://dwb4.unl.edu/Chem/CHEM869A/CHEM869ALinks/www.ualberta.ca/bderksen/florin.html>
- <http://www.sciencedaily.com/releases/2008/07/080704153507.htm>
- <http://www.bestcrystals.com/crystals2.html>

Review Questions

- Identify the most important type of inter-particle force present in the following solids that is responsible for binding the particles into a solid.
 - Kr
 - BaCl₂
 - Mg
 - NaNO₃
 - BCl₃
 - diamond
 - NH₃
- Predict which substance in the following pairs would have the stronger force of attraction between molecules and justify your answer.
 - NaI or I₂
 - solid argon or solid sodium
 - HF or HBr
- An unknown solid is not soluble in water or CCl₄. The solid conducts electricity and has a melting point of 800°C. Identify the most likely attractive forces holding the particles in the solid state.
- An unknown solid is soluble in water but not in CCl₄. The solid does not conduct electricity but its liquid does. The solid shatters when hammered and has a melting point of 1430°C. Identify the most likely attractive forces holding the particles in the solid state.
- Why would you expect ionic solids to have higher melting points than polar solids?
- Why does the melting point of water decrease with increasing surrounding pressure?
- When a drop of liquid is placed on a surface, the more spherical the drop remains is an indication of the strength of the intermolecular forces of attraction. The four drops in the sketch below represent mineral spirits (a non-polar molecule), acetone (a polar molecule), water (a hydrogen bond forming molecule), and mercury (a metallic liquid). Identify each of these liquids as one of the drops (A, B, C, or D).

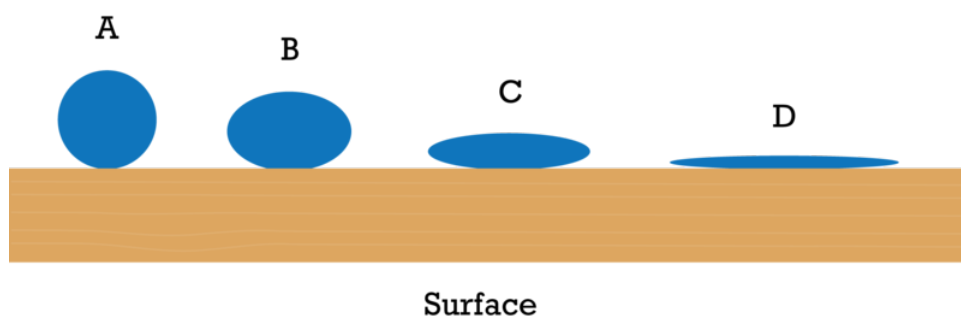

16.4 Vapor Pressure and Boiling

Lesson Objectives

The student will:

- describe the processes of evaporation and condensation.
- describe equilibrium vapor pressure.
- express the relationship between boiling point, vapor pressure, and ambient pressure.
- given a vapor pressure table for water, and the ambient pressure, determine the boiling point of water for those conditions.

Vocabulary

- condensation
- equilibrium vapor pressure
- evaporation
- heat of condensation
- heat of vaporization
- vapor
- vapor pressure

Introduction

The phase of a substance is essentially the result of two competing forces acting on the molecules. The molecules of a substance are pulled together by intermolecular forces of attraction, which could be either weak or strong. The molecules of a substance are also in constant random motion so that they are almost constantly colliding with each other. Without any intermolecular forces of attraction, the molecules of all substances would move away from each other, and there would be no condensed phases (liquids and solids).

If the forces caused by molecular motion are much greater than the intermolecular forces of attraction, the molecules will separate and the substance will be in the gaseous state. If the intermolecular forces of attraction are stronger than the molecular motion, the molecules will be pulled into a closely packed pattern and the substance will be in the solid state. If there is some balance between molecular motion and intermolecular forces of attraction, the substance will be in the liquid state.

When substances are heated (or cooled), their average kinetic energy will increase (or decrease) due to the increase (or decrease) in molecular motion and may result in a phase change. A substance in the solid phase can be heated until the molecular motion balances the intermolecular forces, causing the solid to melt into a liquid. The liquid may be heated until the molecular motion completely overcomes the intermolecular forces, causing the liquid to vaporize into the gaseous state.

Evaporation and Condensation

Evaporation

The temperature in a beaker of water is a measure of the average kinetic energy of the molecules in the beaker. This does not mean that all the molecules in the beaker have the same amount of kinetic energy. Most of the molecules will be within a few degrees of the average, but a few molecules may be considerably hotter or colder than the average. The kinetic energy of the molecules in the beaker will have a distribution curve similar to a standard distribution curve for most naturally occurring phenomena. For most naturally occurring phenomena, most instances of the phenomena will occur near the average. Instances that occur further away from the average are increasingly rare, as seen in the image below.

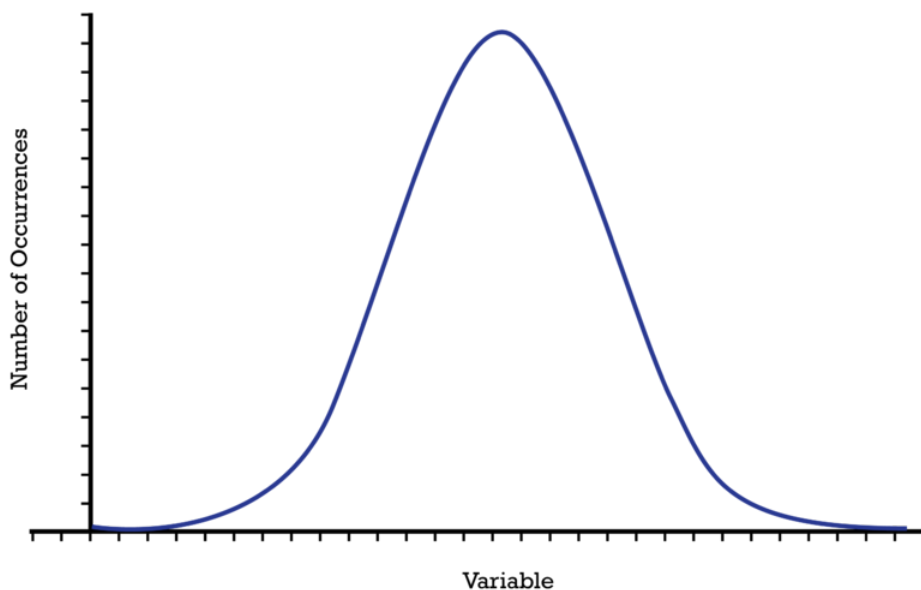

A standard distribution curve like this could represent the length of grasshopper legs in a random sample of grasshoppers or the distribution of IQ for a random sample of humans

In the case of a beaker of water, some of the molecules will have an average temperature below the boiling point, while some of the molecules will have a temperature above the boiling point (see figure below). The dashed yellow line is the average temperature of the molecules and would be the temperature shown on a thermometer inserted into the liquid. The red line represents the boiling point of water (100°C at 1.0 atm pressure), and the area under the curve to the right of the red line represents the number of molecules that are above the boiling point. In order for a molecule above the boiling temperature to escape from the liquid, it must either be on the surface, or it must be adjacent to many other molecules that are above the boiling point so that the molecules can form a bubble and rise to the surface.

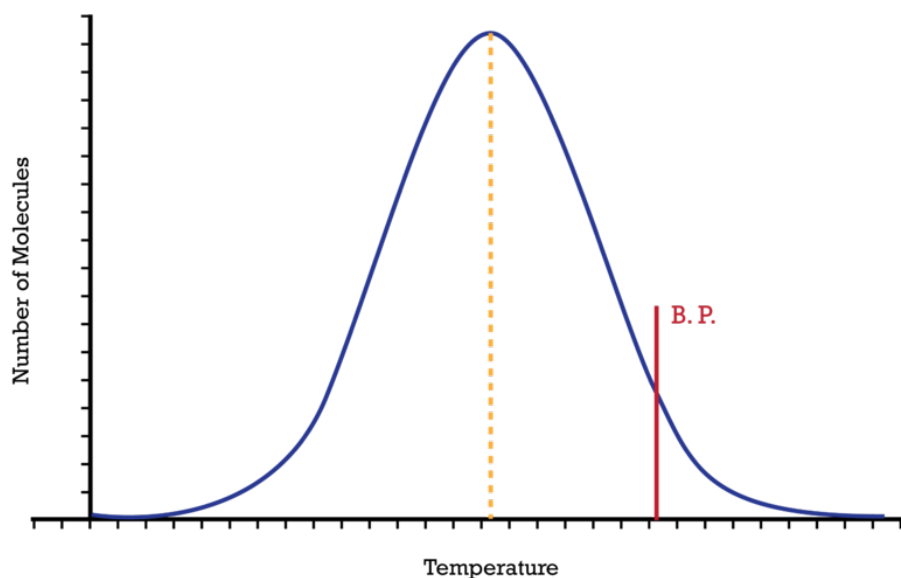

Water boils only when a sufficient number of adjacent molecules are above the boiling point and can form bubbles of gaseous water, as seen below. The process of molecules escaping from the surface of a liquid when the average temperature of the liquid is below the boiling point is called **evaporation**.

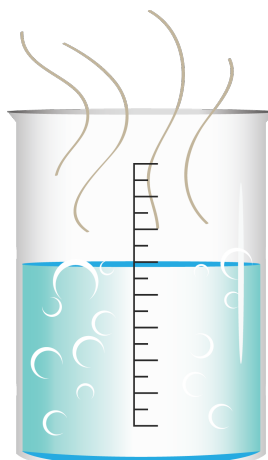

The phase change process is a little more complicated than just having the molecules reach the boiling point. Gaseous molecules have a force of attraction between them due to the separation between the molecules. Recall two oppositely charged objects that are separated have potential energy, and the amount of potential energy can be calculated by multiplying the force of attraction times the distance of separation. At the same temperature, the same molecules in the liquid state and the gaseous state *do not* have the same total energy. If they are at the same temperature, they have the same kinetic energy, but the gaseous molecules have additional potential energy that the liquid molecules do not have. As a result, molecules in the liquid state hot enough to exist in the gaseous state must absorb energy from their surroundings to gain the potential energy needed to change phase. This potential energy is called the **heat of vaporization**.

If a saucer of water is sitting out on the countertop, the water will slowly disappear – yet, at no time is the temperature of the water ever at the boiling point. When molecules of a liquid are evaporating, it is clear that it is the hottest molecules that are evaporating. It might seem that once the hottest molecules are gone, evaporation would no longer continue. This is not true, as the water in an open container continues to evaporate until it is all in the vapor state. When a substance is a **vapor**, the substance is in the gaseous phase even though the substance is at a temperature below its boiling point. Note that a substance in the gaseous phase at temperatures above the boiling point of its liquid

is called a gas, not vapor. Evaporation continues because the temperature of the liquid is the average temperature of all the molecules. When the hottest molecules evaporate, the average temperature of those molecules left behind is lower, so the molecules left behind also contribute to the heat of vaporization to the evaporating molecules. The process of evaporation causes the remaining liquid to cool significantly. Heat flows from warmer objects to colder objects, so when the liquid cools due to evaporation, the surroundings will give heat to the liquid. The temperature of the liquid is raised so that it matches the temperature of the surroundings, thus producing more hot molecules. This process can continue in an open container until the liquid is all evaporated.

The rate of evaporation is related to the strength of the intermolecular forces of attraction, to the surface area of the liquid, and to the temperature of the liquid. As the temperature of a liquid gets closer to the boiling point, more of the molecules will have temperatures above the boiling point, resulting in faster evaporation. Substances with weak intermolecular forces of attraction evaporate more quickly than those with strong intermolecular forces of attraction. Substances that evaporate readily are called volatile, while those that hardly evaporate at all are called non-volatile.

Condensation

Liquids in an open container will usually evaporate completely. What happens, however, if the container is closed? When a lid is placed over the container, the molecules that have evaporated are now kept in the space above the liquid. This makes it possible for a gaseous molecule to condense back to a liquid after colliding with another molecule or a wall, as seen in the figure below. This process where a gas or vapor is changed into a liquid is called **condensation**. Molecules at the boiling point can exist in either the liquid phase or gaseous phase – the only difference between them is the amount of potential energy they hold. See below figure.

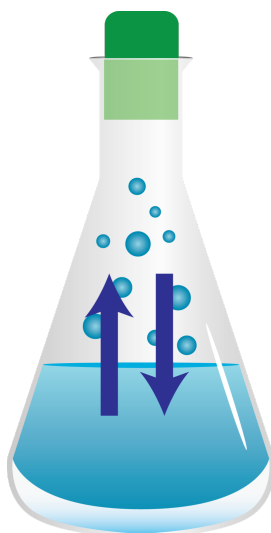

For a liquid molecule with adequate temperature to exist in the gaseous phase, it needs to gain the heat of vaporization. It does this by colliding with adjacent molecules. For a gaseous molecule to return to the liquid phase, it must give up the same amount of potential energy that it gained. This amount of potential energy is called the **heat of vaporization** when it is being gained and the **heat of condensation** when it is being lost, but the amount of energy gained or lost is the same amount.

As more and more molecules evaporate in a closed container, the partial pressure of the gas in the space above the liquid increases. The rate at which the gas condenses is determined by the partial pressure of the gas, the surface area, and the substance involved. Once these factors are established, the rate of condensation will only vary depending on the partial pressure of the gas. As the partial pressure of the gas in the space above the liquid increases, the rate of condensation will increase.

It was pointed out that as a liquid evaporates, the remaining liquid cools because the hottest molecules are leaving, so the average temperature decreases and the heat of vaporization is absorbed from the remaining molecules. For

similar reasons, when a gas is undergoing condensation, the temperature of the remaining gas increases because the coolest molecules are condensing, thus raising the average of those left behind. The condensing molecules must then give up the heat of condensation.

Vapor Pressure

You can follow the progress of evaporation and condensation in a thought experiment. Suppose we place some liquid water in an Erlenmeyer flask and seal it. No water has evaporated yet, so the partial pressure of water vapor in the space above the liquid is zero. As a result, no condensation is taking place. As the water evaporates (at a constant rate since the temperature and surface area are constant), the partial pressure of the water vapor increases. Now that some vapor exists, condensation can begin. Since the partial pressure of the water vapor is low, the rate of condensation will be low. Over time, more and more water evaporates, causing the partial pressure of the water vapor to increase. Since the partial pressure has increased, the rate of condensation also increases.

Eventually, the rate of condensation will become high enough that it is equal to the rate of evaporation. Once this happens, the rate of water molecules entering the vapor phase and the rate of water molecules condensing back into liquid are exactly the same, so the partial pressure no longer increases. When the partial pressure of the water vapor becomes constant, the rate of condensation is constant and is exactly equal to the rate of evaporation. As a result, the pressure exerted by the vapor of a solid or liquid in equilibrium with the vapor is known as the **equilibrium vapor pressure**. As time goes on from this point, neither the amount of liquid or the amount of gas can change; consequently, neither the rate of evaporation nor the rate of condensation can change. Everything remains exactly the same, and evaporation and condensation will continue at exactly the same rate. As seen in **Table 16.2**, a liquid will establish an equilibrium vapor pressure at all temperatures. The pressure of the vapor in the space above the liquid is called the **vapor pressure** of that liquid at that temperature.

TABLE 16.2: Vapor Pressure of Water at Various Temperatures

Temperature in °C	Vapor Pressure in Torr
0	4.6
10	9.2
20	17.5
30	31.8
40	55.3
50	92.5
60	149.4
70	233.7
80	355.1
90	525.8
100	760.0

Volatile liquids would have higher vapor pressures than water at the same temperature, and non-volatile liquids would have lower vapor pressures at the same temperature. The amount of volume for the space above the liquid makes no difference. If the space is small, it will take little gas to produce the pressure, and if the space is large, it will take much more gas to produce the pressure. As long as you introduce enough liquid into the container so that vapor pressure equilibrium will be reached, then the precise vapor pressure will be attained.

Note that the equilibrium vapor pressure of a liquid is the same regardless of whether or not another gas is present in the space above the liquid. If the space above liquid water contains air at 760 torr and the liquid water evaporates until its equilibrium vapor pressure (25 torr) is reached, then the total pressure in the space above the liquid will be 785 torr. The presence of the air in no way affects the vapor pressure.

When gaseous substances are produced from chemical reactions and collected in the laboratory, they are usually collected over water. The “collection over water” technique is inexpensive and allows gaseous substances to be collected without having air mixed in. The process involves filling a collecting jar with water and inverting the jar in a pan of water without letting any water out or air in, as illustrated below.



In the sketch above, the picture on the far left represents the collecting jar full of water and inverted in a pan of water. A tube runs from the reaction vessel where the gas is produced and is tucked under the edge of the collecting jar. As the gas is produced and comes out the end of the tube, it bubbles up through the water and pushes the water out of the jar. When the water in the collecting jar and the pan are exactly level, as in the picture at the far right, the pressure inside the collecting jar and the atmospheric pressure in the lab are equal. Using the pressure and temperature in the lab, as well as the volume of the jar to the water level, you can calculate how much gas you produced. (Plug P and R into $PV = nRT$ and solve for n). It turns out, however, that you must make a correction before you plug in the pressure value. Since the collecting jar is a closed container and it has liquid water in the bottom of it, it will contain the vapor pressure of water at this temperature. Consequently, the pressure in the lab tells you the pressure inside the collecting jar, but it doesn't tell you how much of that pressure is due to the gas collected and how much is due to water vapor. You must get a table of the vapor pressure of water at each temperature and look up the vapor pressure of water at the temperature of your lab and then subtract that pressure from the total pressure in the collecting jar. The result will be the actual pressure of the gas collected.

Example:

Some hydrogen gas was collected over water in the lab on a day that the atmospheric pressure was 755 torr and the lab temperature was 20°C. Hydrogen gas was collected in the collecting jar until the water levels inside and outside the jar was equal. What was the partial pressure of the hydrogen in the collecting jar?

Solution:

The total pressure in the collecting jar is 755 torr and is equal to the sum of the partial pressure of hydrogen in the jar and the vapor pressure of water at 20°C. From the table, the vapor pressure of water at 20°C is 17.5 torr.

$$\text{Partial pressure of H}_2 = 755 \text{ torr} - 17.5 \text{ torr} = 737 \text{ torr}$$

The Boiling Point of a Liquid

Imagine you are boiling water in a place where the atmospheric pressure is 1.00 atm. In the boiling water, a large bubble forms near the surface of the liquid. The bubble remains the same size as it rises to the top of the water, where the gas can escape into the air. If the pressure of the gas inside that bubble had been less than 1.00 atm, the outside pressure of the atmosphere would have crushed the bubble. If the pressure of the gas inside that bubble had been greater than 1.00 atm, the bubble would have expanded to a larger size, instead of remaining at the same size. The fact that the bubble remained at the same size indicates that the gas pressure inside that bubble was the same as the atmospheric pressure.

When you are heating water in an effort to boil it, gas bubbles cannot form until the water can produce a vapor pressure equal to the surrounding air pressure. The hotter the water gets, the higher its vapor pressure becomes. The liquid cannot boil, however, until its vapor pressure is equal to the pressure on the surface of the liquid. The boiling point is the temperature at which the vapor pressure of the liquid equals the surrounding pressure.

If you are measuring boiling points at the normal sea level atmospheric pressure of 1.00 atm, a liquid more volatile than water such as chloroform will boil at 61.3°C. This is because the vapor pressure of chloroform is 1.00 atm at 61.3°C. The vapor pressure of ethanol reaches 1.00 atm at a temperature of 78.4°C, so this is the normal boiling point of ethanol.

Since liquids boil when their vapor pressures become equal to the surrounding pressure, if the surrounding pressure is lower, the liquids will boil at lower temperatures. At higher altitudes, atmospheric pressure is lower. In cities whose altitude is around 5,000 feet, water boils at 95°C instead of at 100°C, and at 10,000 feet, water boils around 90°C. The water boils in normal fashion, but its temperature is lower. As a result, cooking in boiling water takes a longer time at higher altitudes.

If a container of water is placed in a bell jar and a vacuum pump attached so that the air pressure around the water can be greatly reduced, water may be made to boil at very low temperatures. At room temperature, 20°C, the vapor pressure of water is 17.5 mm of Hg, so if the pressure in the bell jar is reduced to 17.5 mm of Hg, water will boil at 20°C. The appearance of the boiling water is the same as it is at 100°C, but the water can be removed from the bell jar and poured on your hand without burning.

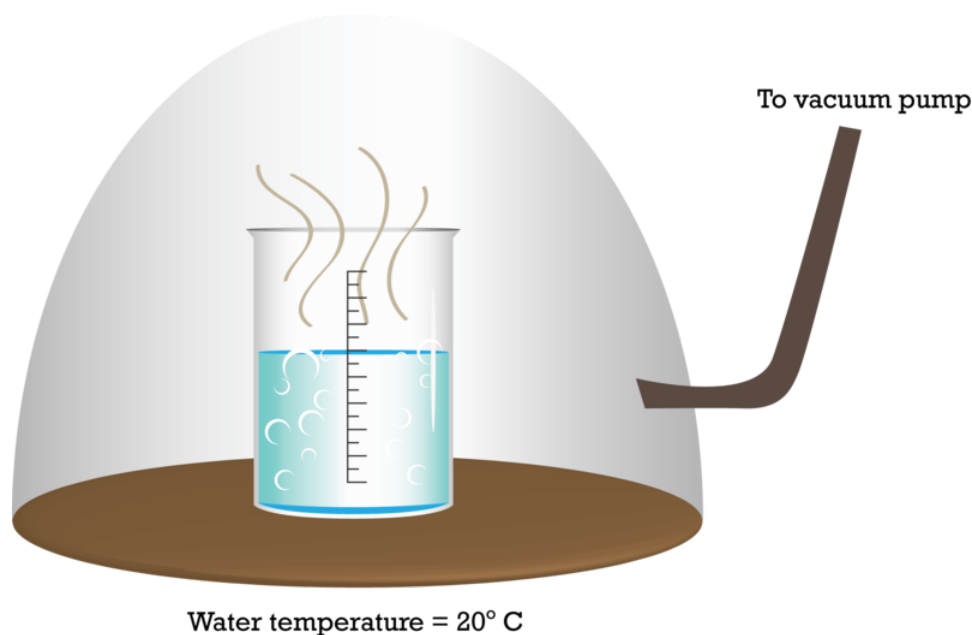

If the surrounding pressure is less than 1.00 atm, the boiling points of liquids will be lower. Conversely, if the surrounding pressure is greater than 1.00 atm, the boiling points of liquids will be higher. If we use a strong container with a lid that screws on very tightly, as we boil water in the container, the gas pressure in the container will increase. As the pressure in the container increases, the boiling point of the water increases. The vapor pressure of liquid water at 120°C is 2.00 atm. Therefore, if we can raise the pressure inside a sealed container to 2.00 atm, water will not boil in the container until its temperature is 120°C. This is the concept that is used in pressure cookers and rice cookers. The cooking pot has a tightly sealing lid and a valve in the lid. The valve will open slightly when the pressure inside the container reaches 2.00 atm, helping to maintain the inside pressure at 2.00 atm. The pressure and the boiling point of water will therefore increase inside the container until the pressure reaches 2.00 atm. The temperature of the boiling water inside will be 120°C. Under these conditions, any food placed inside the pressure cooker will cook in as little as one-third the normal time.

Lesson Summary

- Molecules of liquid may evaporate from the surface of a liquid.
- When molecules of a liquid evaporate, the remaining liquid cools.
- Gas molecules in contact with their liquid may condense to liquid form.
- If a liquid is placed in a closed container, eventually vapor pressure equilibrium will be reached.
- The boiling point of a liquid is the temperature at which the vapor pressure of the liquid becomes equal to the surrounding pressure.
- The normal boiling of a liquid is the temperature at which the vapor pressure of the liquid becomes equal to 1.00 atmosphere.

Further Reading / Supplemental Links

The following website provides more information about vapor pressure.

- <http://www.chem.purdue.edu/gchelp/liquids/vpress.html>

This video is a ChemStudy film called “Gas Pressure and Molecular Collisions.” The film is somewhat dated but the information is accurate.

- <http://www.youtube.com/watch?v=fK6LfN6CD0w>

Review Questions

1. In the following groups of substances, pick the one that has the requested property and justify your answer.
 - a. highest boiling point: HCl, Ar, F₂
 - b. highest melting point: H₂O, NaCl, HF
 - c. lowest vapor pressure at 20°C: Cl₂, Br₂, I₂
2. A flask half-filled with water is sealed with a stopper. The space above the water contains hydrogen gas and water vapor in vapor pressure equilibrium with the liquid water. The total pressure of the two gases is 780. mm of Hg at 20.°C. The vapor pressure of water at 20.°C is 19 mm of Hg. What is the partial pressure of the hydrogen gas in the flask?
3. Describe all the reasons that the remaining liquid cools as evaporation occurs.
4. Describe all the reasons that the remaining gas gets hotter as condensation occurs.

16.5 Heat and Changes of State

Lesson Objectives

The student will:

- calculate the energy changes during phase changes.
- explain the slopes of the various parts in heating and cooling curves.
- explain why it is necessary for a solid to absorb heat during melting even though no temperature change is occurring.
- calculate, given appropriate thermodynamic data, the heat required to raise temperatures of a given substance with no phase change.
- calculate, given appropriate thermodynamic data, the heat required to melt specific samples of solids with no temperature change.
- calculate, given appropriate thermodynamic data, the heat required to produce both a phase change and temperature change for a given sample of solid.

Vocabulary

- freezing
- freezing point
- fusion
- heat of fusion
- melting
- melting point
- specific heat

Introduction

In order to vaporize a liquid, heat must be added to raise the kinetic energy (temperature) to the boiling point. Upon reaching the phase change temperature, additional heat is still needed to provide the potential energy to separate the molecules into gaseous form.

The melting point of a substance, like its boiling point, is directly related to the strength of the forces of attraction between molecules. Low melting points are typical of substances whose forces of attraction are very weak, such as hydrogen gas whose melting point is -259°C . High melting points are associated with substances whose forces of attraction are very strong, such as elemental carbon whose melting point is greater than 3500°C .

Heating and Melting Curves

The addition of heat before, during, and after a phase transition can be analyzed with the help of a heating curve. In the heating curve below, a sample of water at -20°C and 1.00 atm pressure is heated at a constant rate.

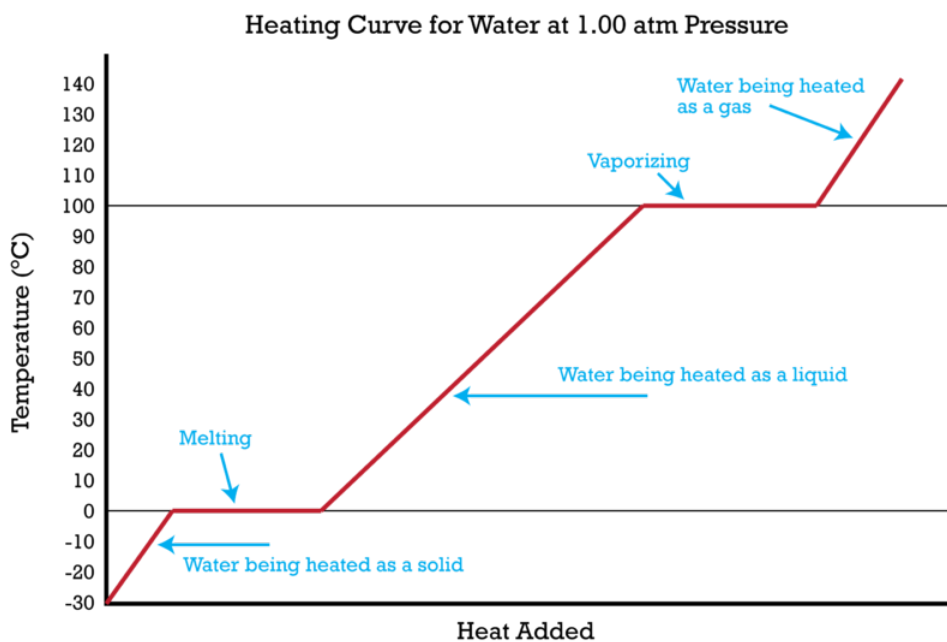

Between the temperatures of -20°C and 0°C , all the heat added is absorbed as kinetic energy, causing the temperature of the solid to increase. Upon reaching the melting point, even though heat is still being added at the same rate, the temperature does *not* increase. All the heat added during this time goes into providing the potential energy needed to melt the solid; this energy represents the heat of melting. During this flat line period, an observer would see the water changing from solid to liquid. Both the water in solid form and the water in liquid form would be at exactly 0°C . Adding more heat causes the water to melt faster, but the temperature does not increase until all of the solid has been converted to liquid. If the liquid is cooled, it follows this same curve in reverse. As it is cooled, the same flat line appears while the heat of fusion is removed before the temperature may go down again.

Once all the water is in the liquid form, the heat is again absorbed as kinetic energy. Between the temperatures of 0°C and 100°C , the heat added causes the temperature increases. Upon reaching the boiling point, the temperature again does not increase even though heat is added. All the heat added to the sample during the time that the slope of the line is zero goes into potential energy. This energy represents the heat of vaporization and is used to separate the liquid molecules into the gaseous form. During this flat line period, an observer would see that the water was changing into gas, but both the liquid part and the gaseous part would be at exactly 100°C . Adding more heat causes the water to boil faster, but its temperature will never exceed 100°C . Once all the water is in the gaseous form, the heat can again go into raising the kinetic energy and temperature of the gas. When the gas is cooled, it follows this same curve in reverse. As it is cooled, the same flat line appears while the heat of condensation is removed before the temperature may drop.

This video contains a lecture covering the energy involved in phase changes (7c): <http://www.youtube.com/watch?v=wx0UAFMZkMw> (6:28).

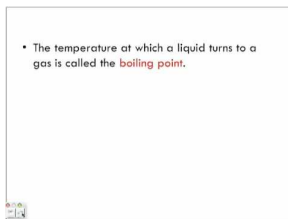
**MEDIA**

Click image to the left for more content.

Specific Heat

Thermodynamic data (melting point, boiling point, heat of melting, heat of vaporization) for almost all the elements and for thousands of compounds are available in various reference books and on the internet. One useful piece of thermodynamic data is the specific heat. Symbolized by the letter C , the **specific heat** for a substance is the amount of heat required to raise 1.00 gram of the substance by 1.00°C . For liquid water, the specific heat is $4.18 \text{ J/g}\cdot^{\circ}\text{C}$.

Example:

How much heat is required to raise the temperature of 25 grams of water from 15°C to 55°C ?

Solution:

$$Q = mC\Delta T = (25 \text{ g})(4.18 \text{ J/g}\cdot^{\circ}\text{C})(40.0^{\circ}\text{C}) = 4180 \text{ J} = 4.18 \text{ kJ}$$

Melting and Freezing Points

Solids, like liquids, have a vapor pressure. Like liquids, the vapor pressure of a solid increases with temperature. At 100°C , the vapor pressure of liquid water is 760 mm of Hg. As the temperature decreases to 0°C , the vapor pressure decreases (non-linearly) to 4.6 mm of Hg.

The vapor pressure of a solid is generally very low because the forces of attraction in solids are strong. For example, at -83°C , the vapor pressure of ice is 0.00025 mm of Hg. As ice is heated, its vapor pressure increases. At 0°C , the vapor pressure of ice is 4.6 mm of Hg, which also happens to be the vapor pressure of water at 0°C . In fact, for all substances, their solids and liquids have the same vapor pressure at the melting point. The **melting point** of a solid is defined as the temperature at which the vapor pressure of the solid and liquid are the same. Therefore, the melting point of the solid and the **freezing point** of the liquid are exactly the same temperature.

Heat of Fusion

Melting, the phase change from solid to liquid, has many similarities to vaporization. The solid must reach its melting point before the molecules can enter the liquid phase. The molecules in liquid phase, however, are farther apart than the molecules in the solid phase. Since the molecules attract each other, increasing the distance between them requires work. The work done in separating the molecules is stored in the molecules as potential energy in the liquid phase. This is the same process that occurs when the heat of vaporization must be added to liquid molecules to get them into the gaseous phase. In the case of melting, this potential energy is called the **heat of fusion**, or the heat of melting.

The word "fusion" is used several times in science with different meanings. You need to note the context in order to determine which meaning is intended. In this case, **fusion** refers to the change from the liquid to solid phase. When

a solid melts, the heat of fusion must be added, and when a liquid **freezes** (fuses) back to solid, the heat of fusion is given off. The heat of fusion for water is 334 joules/gram.

Example:

How much heat must be added to 25 g of ice at 0°C to convert it to liquid water at 0°C?

Solution:

$$Q = (\text{mass})(\Delta H_{FUSION}) = (25 \text{ g})(334 \text{ J/g}) = 8350 \text{ J} = 8.4 \text{ kJ}$$

Heat of Vaporization

The difference between the liquid phase and the gas phase of a substance is essentially the distance between the molecules. Since the molecules attract each other and are separated by a greater distance in the gaseous phase than in the liquid phase, the molecules in the gaseous phase possess more potential energy than in the liquid phase. When a substance changes from the liquid phase to the gaseous phase, work must be done on the molecules to pull them away from each other. The work done separating the molecules is stored in the molecular structure as potential energy. If the molecules are allowed to condense back into the liquid phase, the potential energy is released – exactly the same amount that was needed to separate the molecules. This potential energy stored in molecules in the gaseous phase is called the heat of vaporization. The heat of vaporization (ΔH_{VAP}) for water is 540 calories/gram, which is 2.26 kJ/g at the normal boiling point. Because of the strength of the polar attractions holding water molecules together in the liquid form, water has a fairly high heat of vaporization. Other examples of polar molecules are ammonia, NH_3 , and ethanol, $\text{C}_2\text{H}_5\text{OH}$, which have heats of vaporization of 1.38 kJ/g and 0.84 kJ/g, respectively.

Example:

How much heat in kJ is necessary to vaporize 100. grams of ammonia at its boiling point?

Solution:

$$Q = (\text{mass})(\Delta H_{VAP}) = (100. \text{ g})(1.38 \text{ kJ/g}) = 138 \text{ kJ}$$

The boiling point of ammonia is -33°C . It is very important to understand that the ammonia is at the boiling point before *and* after the heat of vaporization is added. All the energy involved in the heat of vaporization is absorbed by the substance as potential energy; none of it goes into kinetic energy, so the temperature cannot change.

To test your understanding of this point, determine which would produce a more severe burn: spilling boiling water at 100°C on your skin or being burned by gaseous water at 100°C . At first it may seem that they would do the same damage since they are both at the same temperature, but in fact, the gaseous water would do more damage. The gaseous water would release a tremendous amount of heat (heat of vaporization) to your skin as it condenses to water before burning your skin as 100°C water.

Example:

How much heat is required to raise the temperature of 25 grams of liquid water from 25°C to gaseous water at $100.^\circ\text{C}$?

Solution:

In this problem, you have to calculate the heat needed to raise the temperature of the liquid water from 25°C to $100.^\circ\text{C}$ and then the heat of vaporization for the 25 g of water.

$$\text{Heating: } Q = mC\Delta T = (25 \text{ g})(4.18 \text{ J/g}\cdot^\circ\text{C})(75^\circ\text{C}) = 7838 \text{ J} = 7.8 \text{ kJ}$$

$$\text{Vaporizing: } Q = mH_{VAP} = (25 \text{ g})(2.26 \text{ kJ/g}) = 56.5 \text{ kJ}$$

$$Q_T = 7.8 \text{ kJ} + 56.5 \text{ kJ} = 64.3 \text{ kJ}$$

Example:

A 2,000. grams mass of water in a calorimeter has its temperature raised by 3.00°C while an exothermic chemical reaction is occurring. How much heat, in joules, is transferred to the water by the heat of reaction?

Solution:

The heat is calculated by determining the heat absorbed by the water. This amount of heat is the product of three factors: 1) the mass of the water, 2) the specific heat of water, and 3) the change in temperature of the water.

$$Q = (\text{mass of water})(C_{\text{water}})(\Delta T) = (2000. \text{ g})(4.18 \text{ J/g}\cdot^\circ\text{C})(3.00^\circ\text{C}) = 25,080 \text{ J} = 25.1 \text{ kJ}$$

Example:

A 1,000. gram mass of water whose temperature was $50.^\circ\text{C}$ lost 33,400 J of heat over a 5-minute period. What was the temperature of the water after the heat loss?

Solution:

$$Q = (\text{mass})(C_w)(\Delta T) = \frac{\text{heat}}{(\text{mass})(C_w)} = \frac{-33,400 \text{ J}}{(1000. \text{ g})(4.18 \text{ J/g}\cdot^\circ\text{C})} = -8.00^\circ\text{C}$$

If the original temperature was $50.^\circ\text{C}$ and the temperature decreased by 8°C , then the final temperature would be 42°C .

Example:

Use the thermodynamic data given to calculate the total amount of energy necessary to raise 25 grams of ice at $-20.^\circ\text{C}$ to gaseous water at $120.^\circ\text{C}$.

Data:

- Melting point of ice = 0°C
- Boiling point of water = 100°C
- ΔH_{VAP} for water = 2260 J/g
- ΔH_{FUSION} for water = 334 J/g
- $C_{\text{ice}} = 2.11 \text{ J/g}\cdot^\circ\text{C}$
- $C_{\text{water}} = 4.18 \text{ J/g}\cdot^\circ\text{C}$
- $C_{\text{water vapor}} = 1.84 \text{ J/g}\cdot^\circ\text{C}$

Solution

There will be five steps in the solution process.

1. We must calculate the heat required to raise the temperature of the ice from $-20.^\circ\text{C}$ to 0°C .

$$\text{Raising the temperature of ice, } Q = mC\Delta T = (25 \text{ g})(2.11 \text{ J/g}\cdot^\circ\text{C})(20^\circ\text{C}) = 1055 \text{ J}$$

2. We must calculate the heat required to provide the heat of melting in order to change ice at 0°C to water at 0°C .

$$\text{Melting ice to liquid, } Q = (\text{mass})(\Delta H_{\text{FUSION}}) = (25 \text{ g})(334 \text{ J/g}) = 8350 \text{ J}$$

3. We must calculate the heat required to raise the temperature of the liquid water from 0°C to 100°C .

$$\text{Raising the temperature of liquid, } Q = mC\Delta T = (25 \text{ g})(4.18 \text{ J/g}\cdot^\circ\text{C})(100^\circ\text{C}) = 10450 \text{ J}$$

4. We must calculate the heat required to provide the heat of vaporization to change liquid water at 100°C to gaseous water at 100°C.

$$\text{Vaporizing liquid to gas, } Q = (\text{mass})(\Delta H_{VAP}) = (25 \text{ g})(2260 \text{ J/g}) = 56500 \text{ J}$$

5. Finally, we must calculate the heat required to raise the temperature of the gaseous water from 100°C to 120°C.

$$\text{Raising the temperature of gas, } Q = mC\Delta T = (25 \text{ g})(1.84 \text{ J/g}\cdot^{\circ}\text{C})(20^{\circ}\text{C}) = 920 \text{ J}$$

The sum of all five steps is 77,275 J = 77 kJ

The cooling process would be the exact reverse of the heating process. If water in the gaseous phase is cooled, each 1.84 joules of heat removed would lower the temperature of 1.00 g of gas by 1.00°C. When the gaseous water reaches the boiling point (also the condensation point), each gram of gaseous water that condenses to liquid will release 2260 joules of heat. Once all the water is in the liquid form, the removal of each 4.18 joules of heat by cooling will cause the temperature of 1.00 g of water to cool by 1.00°C. At the freezing point (also the melting point) 334 joules of heat must be removed to convert each gram of liquid water to ice. When the entire sample of water is in the form of ice, 2.26 joules of heat must be removed to cool each gram by 1.00°C.

This video serves a blackboard lecture on the mathematics of heat involved in temperature change and phase change (7d): http://www.youtube.com/watch?v=zz4KbvF_X-0 (14:49).

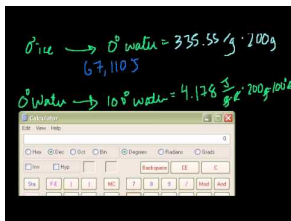

MEDIA

Click image to the left for more content.

Lesson Summary

- In heating and cooling curves, temperature change is associated with a change in kinetic energy, while no temperature change is associated with a change in potential energy.
- The specific heat of a substance is the amount of heat required to raise the temperature of one gram of the substance by 1.0°C.
- The heat of vaporization of a liquid is the quantity of heat required to vaporize a unit mass of that liquid at constant temperature.
- The energy released when a gas condenses to a liquid is called the heat of condensation.
- Solids melt when the vapor pressure of the solid equals the vapor pressure of the liquid.
- Heat must be absorbed by a solid to become a liquid even though the temperature remains the same. The quantity of heat absorbed per unit mass is called the heat of fusion.
- Stronger forces of attraction between particles in solids produce higher melting points and higher heats of fusion.

Further Reading / Supplemental Links

This video explores how matter changes state depending on the temperature.

- <http://www.videopediaworld.com/video/29170/Exploring-Heat-Change-of-State>

Review Questions

Use the thermodynamic data given in the following table (**Table 16.3**) to answer problems 1 - 5.

TABLE 16.3: Thermodynamic Data of Various Substances

	Water	Cesium, Cs	Silver, Ag
Melting Point	0°C	29°C	962°C
Boiling Point	100.°C	690.°C	2162°C
ΔH_{fusion}	334 J/g	16.3 J/g	105 J/g
$\Delta H_{\text{vaporization}}$	2260 J/g	669 J/g	2362 J/g
Specific Heat, C, for Gas	2.01 J/g·°C	0.167 J/g·°C	0.159 J/g·°C
Specific Heat, C, for Liquid	4.18 J/g·°C	0.209 J/g·°C	0.294 J/g·°C
Specific Heat, C, for Solid	2.09 J/g·°C	0.251 J/g·°C	0.235 J/g·°C

1. How many joules are required to melt 100. grams of silver at its normal melting point with no temperature change?
2. How many joules are required to boil 150. grams of cesium at its normal boiling point with no temperature change?
3. How many joules are required to heat 200. g of liquid water from 25°C to steam at 125°C under normal pressure?
4. How many joules are required raise the temperature of 1.00 gram of water from -269°C (the current temperature of space) to $1.60 \times 10^{15}^{\circ}\text{C}$ (the estimated temperature of space immediately after the Big Bang)?
5. How many joules are required to raise the temperature of 1000. g of cesium from $-200.^{\circ}\text{C}$ to $+200.^{\circ}\text{C}$?
6. Why does the boiling point of water increase with increasing surrounding pressure?
7. Why must heat be absorbed to melt a solid even though both the solid and the liquid are at the same temperature?

Use the image below for problems 8 - 10.

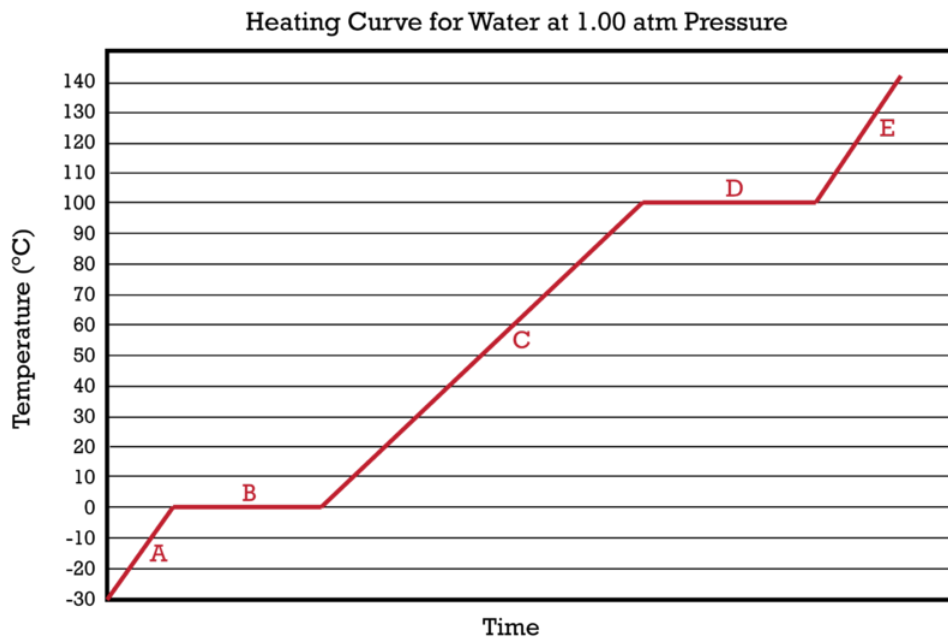

8. What is happening to the water in section B?
9. What is happening to the water in section A?
10. Why are the slopes of the lines in sections A, C, and E different?

16.6 Phase Diagrams

Lesson Objectives

The student will:

- read requested information from a phase diagram.
- state the primary difference between a generic phase diagram and a phase diagram for water.

Vocabulary

- critical pressure
- critical temperature

Introduction

A phase diagram is a convenient way of representing the phase of a substance as a function of temperature and pressure. Phase diagrams are produced by altering the temperature of a pure substance at constant pressure in a closed system. This process is repeated at many different pressures, and the resultant phases charted.

Generic Phase Diagrams

The phase diagram seen below is a generic phase diagram that would be produced by many pure substances. Differences in the diagram would be in the specific thermodynamic points, such as the melting point and boiling point, and in the slopes of the curved lines.

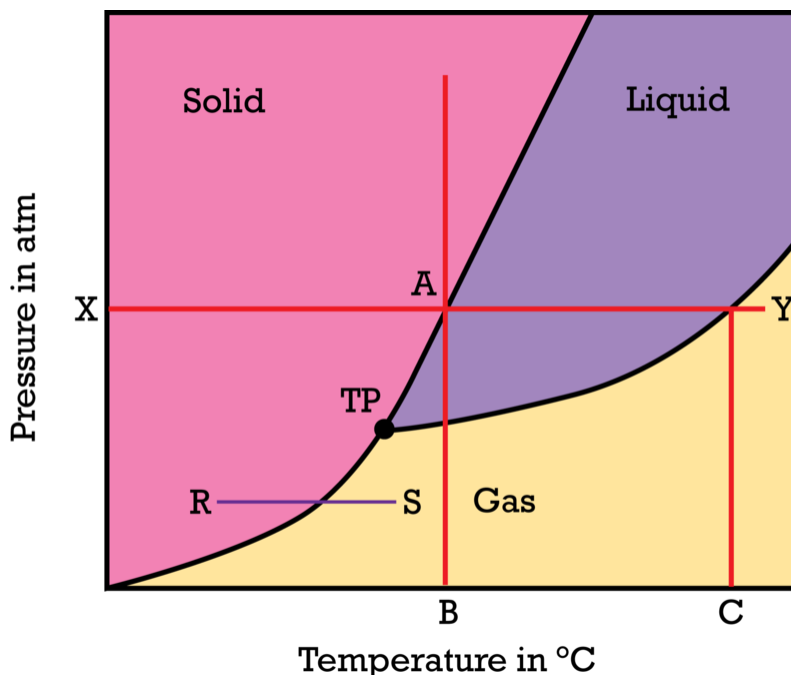

The pink area in the diagram represents the solid state, the purple area represents the liquid state, and the yellow area represents the gaseous state. Following a constant pressure line, such as line X, shows that the phase of the substance at different temperatures at this pressure. Since the line crosses from solid into liquid at point A, this temperature would be the melting point of the substance. Continuing along the line, we see it crosses from liquid to gas at the point corresponding with temperature C. This is the boiling point of the substance at pressure X.

The line between the pink and purple areas represent the various melting points at different pressures, while the line separating the purple area from the yellow area represents the boiling point at various pressures. At the melting points, both solid and liquid can exist at the same time as the phase changes occurs. Similarly, at the boiling points, the substance may exist in both liquid and gas phase at the same time. There is one point on the diagram where all three phases may exist at one time. This point is called the triple point. The pressure at this point is called the triple point pressure, and the temperature at this point is called the triple point temperature.

There is also a line separating the pink area from the yellow area. This line represents the phase change in which a solid changes directly to a gas without passing through the liquid phase. This phase change is known as sublimation. All substances undergo sublimation at the appropriate pressures. We do not see sublimation often because the pressures are frequently quite low. One example of sublimation that we can observe at normal atmosphere (1.00 atm) is carbon dioxide, CO_2 , in its solid form, which is also known as dry ice. If you have seen dry ice, you would notice that the substance goes from the solid phase to the gaseous phase at room conditions without passing through a liquid phase. In the phase diagram for dry ice, we would see that the triple point is above normal atmospheric pressure, so at standard conditions, carbon dioxide undergoes sublimation.

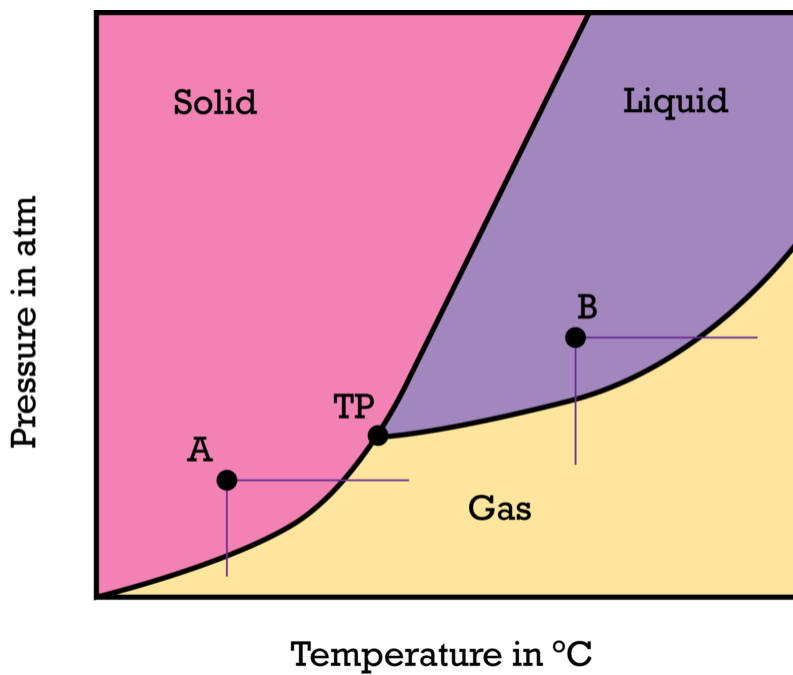

The figure above shows the same generic phase diagram we looked at earlier. Two points have been added to the diagram, labeled A and B. You should note that the substance at point A can be caused to go through a phase change from solid to gas (sublimation) in two different ways. The substance could be heated at constant pressure, or the substance could undergo a lowering of pressure at constant temperature. Both of these procedures would cause the solid to undergo sublimation. Point B is similar except that the substance begins as a liquid. The liquid at point B could be caused to undergo a phase change into a gas by either heating the liquid at constant pressure or by lowering the pressure at constant temperature. You might also note that the substance at the triple point will become a solid if the pressure is increased and will become a gas if the pressure is decreased.

The Phase Diagram for Water

The phase diagram for water has one very interesting difference from the generic phase diagram. Please note that this diagram is not drawn to scale. If the distance between 1.0 atm and 218 atm was drawn to scale, the difference between 1.0 atm and 0.006 atm would be invisible. The diagram is drawn just to show specific points of interest.

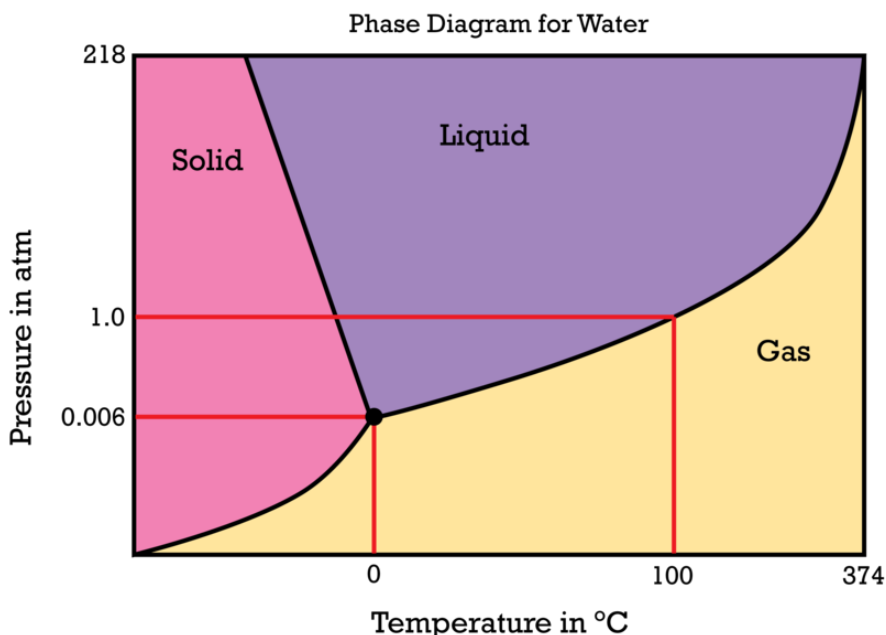

The primary difference in the shape of this diagram and the generic diagram is that the solid-liquid equilibrium line has a negative slope. A positive slope indicates that as pressure increases, the melting point increases. In other words, more pressure on the surface would require a higher temperature to overcome that extra pressure to melt the substance. The negative slope of this line in the water diagram indicates that as the pressure increases, the melting point of water decreases. The reason this occurs is because the increased pressure breaks some of the hydrogen bonds in the water, so less thermal energy is needed to melt ice at higher pressures.

This property of water is evidenced in various situations. We all think of ice as being a very slippery substance, but the surface of ice is no different from the surface of many other solids. The reason that we slip on ice is because when you stand on ice, the pressure of your weight causes the ice to melt, which causes the surface to be slippery. Another example of this is in the track of the blade left by an ice skate. If you look closely at the track, you'll see that the track is filled with liquid.

If you follow the line at a pressure of 1.0 atm for water, you see that the temperatures at the melting and boiling points are what we expected. The triple point for water is at 0.006 atm and 0.0098°C, which also means that the pressure and temperature at which ice water sublimates to water vapor are very low. There are commercial processes that make use of the sublimation of water. Foods that are referred to as "freeze dried" have the surrounding pressure and temperature reduced to a point below the triple point. The food is then heated while a vacuum pump removes vapor to keep the pressure below the triple point pressure. This causes the water in the food to sublime, which is drawn off by the pump. The end result is that all the water will be removed from the food.

As the temperature of liquid is raised, the amount of pressure that is required to keep the substance in liquid form also increases. Liquids will eventually reach a temperature at which no amount of pressure will keep it in the liquid form. The substance at that temperature will vaporize regardless of the amount of pressure on it. The highest temperature a liquid reaches and can still be maintained as a liquid is called the **critical temperature**. The pressure that is required at the critical temperature to force the substance to stay in liquid form is called the **critical pressure**. The critical temperature and pressure for water is 374°C and 218 atm.

Lesson Summary

- Phase diagrams show the phase of a substance at various temperatures and pressures.
- The phase diagram for water is different from most phase diagrams because the melting point of water

decreases as pressure increases.

Further Reading / Supplemental Links

To look at more phase diagrams, visit the website:

- <http://www.kentchemistry.com/links/Matter/Phasediagram.htm>

Review Questions

1. Consider the phase diagram below. Name the phases that may be present at each lettered point in the diagram.

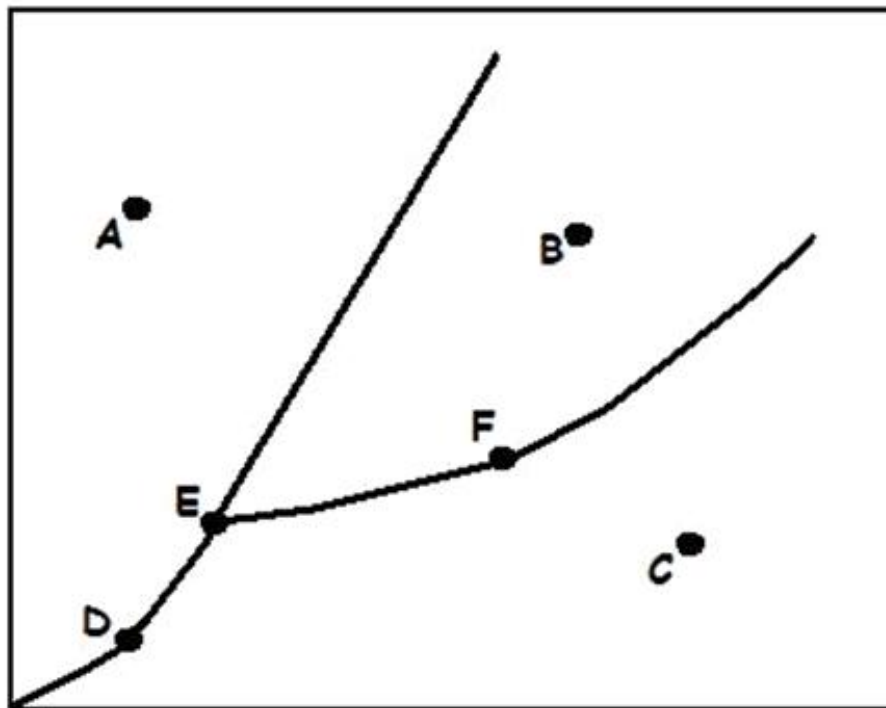

Use the phase diagram for water below to answer the remaining questions.

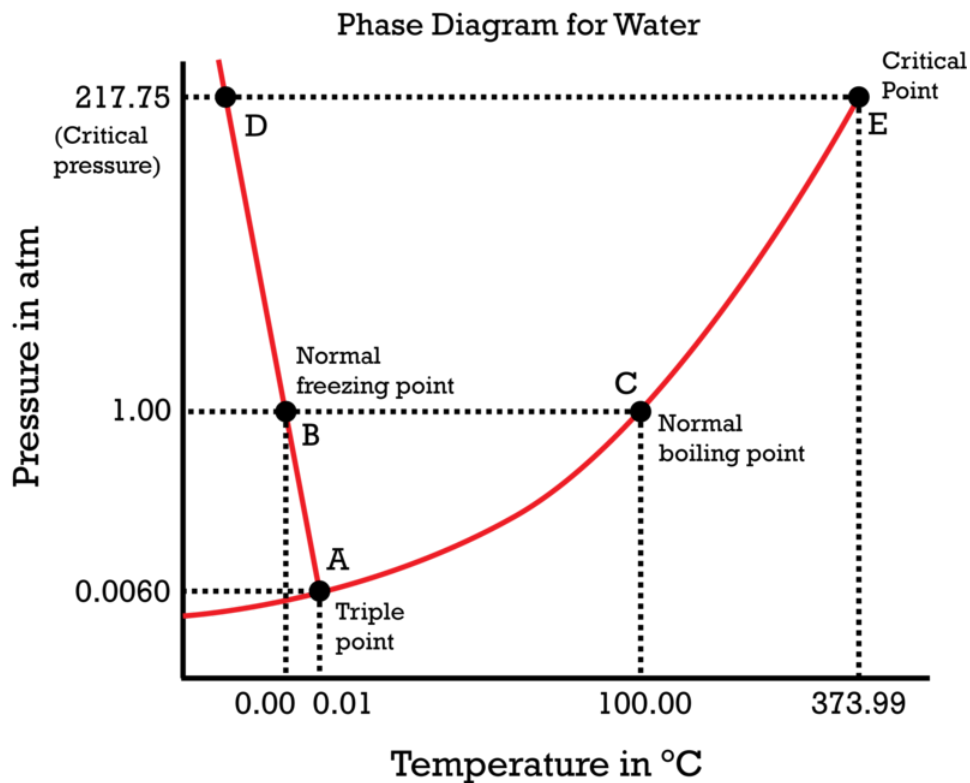

2. What is the state of water at 2.0 atm and 50.°C?
3. What phase change will occur if the temperature is lowered from 80.°C to -5°C at 1.0 atm?
4. You have ice at -10°C and 1.0 atm. What could you do in order to cause the ice to sublime?

All images, unless otherwise stated, are created by the CK-12 Foundation and are under the Creative Commons license CC-BY-NC-SA.

16.7 References

1. Courtesy of United States Geological Survey and Mineral Information Institute. [Asbestos \(chrysotile\)](#). Public domain

CHAPTER 17**Solutions and Their Behavior****Chapter Outline**

- 17.1 PROPERTIES OF SOLUTIONS**
 - 17.2 SOLUTION FORMATION**
 - 17.3 MEASURING CONCENTRATION**
 - 17.4 FACTORS AFFECTING SOLUBILITY**
 - 17.5 SOLUBILITY GRAPHS**
 - 17.6 COLLIGATIVE PROPERTIES**
 - 17.7 SEPARATING MIXTURES**
 - 17.8 REACTIONS BETWEEN IONS IN SOLUTIONS**
 - 17.9 REFERENCES**
-

17.1 Properties of Solutions

Lesson Objectives

The student will:

- define a solution.
- describe the composition of solutions.
- define the terms solute and solvent.
- identify the solute and solvent in a solution.
- describe the different types of solutions and give examples of each type.
- define colloids and suspensions.
- explain the differences among solutions, colloids, and suspensions.
- list some common examples of colloids.

Vocabulary

- colloid
- solute
- solution
- solvent
- suspension
- Tyndall effect

Introduction

In this chapter, we begin our study of solution chemistry. We all might think that we know what a solution is, listing a drink like tea or soda as an example of a solution. What you might not have realized, however, is that the air or alloys such as brass are all classified as solutions. Why are these classified as solutions? Why wouldn't milk be classified as a true solution? To answer these questions, we have to learn some specific properties of solutions. Let's begin with the definition of a solution and look at some of the different types of solutions.

Homogeneous Mixtures

A **solution** is a homogeneous mixture of substances (the prefix “homo-” means “same”), meaning that the properties are the same throughout the solution. Take, for example, the vinegar that is used in cooking. Vinegar is approximately 5% acetic acid in water. This means that every teaspoon of vinegar contains 5% acetic acid and 95% water.

When a solution is said to have uniform properties, the definition is referring to properties at the particle level. What does this mean? Consider brass as an example, which is an alloy made from copper and zinc. An alloy is a homogeneous mixture formed when one solid is dissolved in another. To the naked eye, a brass coin seems like it is just one substance, but at a particle level two substances are present (copper and zinc). Now consider a handful of zinc filings and copper pieces. Is this now a homogeneous solution? The properties of any scoop of the mixture you are holding would not be consistent with any other scoop you removed from the mixture, so the combination of zinc filings and copper pieces in a pile does not represent a homogeneous mixture.

The solvent and solute are the two basic parts of a solution. The **solvent** is the substance present in the greatest amount. The **solute**, then, is the substance present in the least amount. When you are making a cup of hot chocolate, you take a teaspoon of cocoa powder and dissolve it in a cup of hot water. Since much less cocoa powder is used than water, the cocoa powder is the solute and the water is the solvent.

Just because solutions have the same composition throughout does not mean the composition cannot be varied. If you were to dissolve a quarter teaspoon of table salt in one cup of water, a solution would form. You can, however, vary the composition of this solution to a point. If you were to add another half teaspoon of salt to the cup of water, you would still make a solution, but the composition of this solution would be different from the last one. What would happen if you tried to dissolve half cup of salt in the water? At this point, the solution has passed its limit as to the amount of salt that can be dissolved in it, so it would no longer be a homogeneous solution. As a result, solutions have a constant composition that can be varied up to a point. There are, however, limits to the amount of substance that can be dissolved into another substance and still remain homogeneous.

Types of Solutions

There are three states of matter: solid, liquid, and gas. If we think about solutions and the possibilities of combining these states together to form solutions, we have nine possibilities. Look at **Table 17.1**.

TABLE 17.1: Types of Solutions

	Solid Solvent	Liquid Solvent	Gaseous Solvent
Solid Solute	Solid in a Solid	Solid in a Liquid	Solid in a Gas
Liquid Solute	Liquid in a Solid	Liquid in a Liquid	Liquid in a Gas
Gaseous Solute	Gas in a Solid	Gas in a Liquid	Gas in a Gas

Although there are nine possibilities, there are really only four common types of solutions. For example, a solid in a liquid solution can be anything from a sugar solution to seawater. Liquid in liquid solutions include vinegar and the antifreeze/coolant used in cars. For a gas in a liquid solution, the most common example is in soft drinks: carbon dioxide is a gas dissolved in water. Another example is the ammonia solution used for cleaning. Finally, to understand a gas in a gas solution, take a deep breath. Air is a solution made up of mostly oxygen gas and nitrogen gas. A solid in a solid solution would be an alloy like steel or brass. The other types of solutions are still solutions, but they are less common in everyday lives.

Example:

Name the solute and solvent in each of the following mixtures.

1. salt water
2. air

Solution:

1. solute = salt; solvent = water

2. solute = oxygen; solvent = nitrogen

Colloids and Suspensions

Unlike solutions, **colloids** are mixtures in which the size of the particles is between 1×10^3 pm and 1×10^6 pm. In meters, these sizes translate to 1×10^{-9} m to 1×10^{-6} m. As a comparison, a small grain of sand has a diameter of 2×10^{-5} m. A common example of a colloid is milk. One way to tell that milk is a colloid is by the **Tyndall effect**. The Tyndall effect is the scattering of light by particles. This involves shining a light through the mixture: when the light cannot pass through the mixture, the mixture is considered a colloid. This is why milk appears “cloudy” – or what we think of as “milky.” When light is passed through a true solution, the particles are so small that they do not obstruct the light. For example, the solution vinegar is clear and allows light to pass through easily. In comparison, when light is passed through a colloid, the larger particles act as an obstruction to the light, causing the light to scatter. The particles, however, are still small enough so that they do not settle out of solution.

Look at **Table 17.2** for some common colloid products that are formed when different phase solutes and solvents are mixed.

TABLE 17.2: Some Common Colloidal Materials

	Solid Solvent	Liquid Solvent	Gaseous Solvent
Solid Solute	Ruby, brass, steel	Butter, cheese, mustard, Jell-o	Marshmallow
Liquid Solute	Paint, milk of magnesia	Milk, mayonnaise, face creams	Whipping cream, shaving cream
Gaseous Solute	Airborn viruses, car ex- haust, smoke	Fog, clouds	Aerosol Sprays

Suspensions are mixtures where the particles settle to the bottom of the container. This means that the particles in a suspension are large enough that gravity pulls them out of solution. With suspensions, filtration can usually be used to separate the excess particles from the solution. A common example of a suspension is muddy water. If you had a beaker of water and stirred in a handful of fine dirt, when you let the mixture stand, dirt would settle to the bottom.

Lesson Summary

- In a solution, a solute is present in the least amount (less than 50% of the solution) whereas the solvent is present in the greater amount (more than 50% of the solution).
- A solution is a mixture that has the same properties throughout.
- Four types of solution can be classified as the most common in terms of everyday occurrence: solid in a liquid, liquid in a liquid, gas in a liquid, and gas in a gas. The other types are less common.
- Colloids are mixtures in which the size of the particles is between 1×10^3 pm and 1×10^6 pm.
- The Tyndall effect involves shining a light through the mixture. If the light scatters, the mixture is a colloid or a suspension.
- Suspensions are mixtures in which the particles are large enough so that they settle to the bottom of the container and can be filtered using filter paper.

Further Reading / Supplemental Links

Lecture slides on solution properties and their behavior are available at the following website.

- http://www.public.asu.edu/~jpbirk/CHM-113_BLB/Chpt13/sld002.htm

Review Questions

1. What makes a solution homogeneous?
2. Which of the following are homogeneous? Explain.
 - a. gasoline
 - b. chocolate
 - c. blood
 - d. brass
3. Which of the following is a solution?
 - a. milk
 - b. blood
 - c. gold
 - d. air
 - e. sugar
4. Which of the following is not a true solution?
 - a. vinegar
 - b. sand and water
 - c. hard water, $\text{CaCO}_3(aq)$
 - d. mercury alloy
5. Give an example of a homogeneous solution that is made from the following combinations:
 - a. a gas in a liquid
 - b. a solid in a solid
 - c. a solid in a liquid
 - d. a gas in a gas
6. Distinguish between a solution, a colloid, and a suspension.
7. What is one true way to tell you have a colloid solution?
8. Why do you think there is no example of a gas - gas colloid?
9. Which is an example of a colloid?
 - a. air
 - b. brass
 - c. milk
 - d. none of these
10. Which is not an example of a colloid?
 - a. human body
 - b. mayonnaise
 - c. mustard
 - d. cloud
11. The biggest difference between a colloid and a suspension is that:

- a. in colloids, the solute is permanently dissolved in the solvent.
 - b. in colloids, the particles eventually settle to the bottom.
 - c. in suspensions, the particles eventually settle to the bottom.
 - d. none of these are correct
12. Karen was working in the lab with an unknown solution. She noticed that there was no precipitate in the bottom of the beaker even after it had been on the lab bench for several days. She tested it with a light and saw that light scattered as it passed through the solution. Karen concluded that the liquid was what type of a mixture?
- a. colloid
 - b. suspension
 - c. homogeneous
 - d. heterogeneous
13. What are two good common examples of colloids?

17.2 Solution Formation

Lesson Objectives

The student will:

- define the terms miscible and immiscible.
- explain why solutions form.
- predict if a solution will form between two substances from their molecular formulas.
- discuss the idea of water as the “universal solvent.”
- explain the solvation of molecules in comparison to ionic solvation.
- discuss the differences between electrolytes and non-electrolytes and give examples of each.
- determine from the formula whether a compound is an electrolyte or a non-electrolyte.
- identify electrolyte and non-electrolyte solutions by their properties.

Vocabulary

- electrolyte
- hydration
- immiscible
- miscible
- non-electrolyte

Introduction

We have learned that solutions can be formed in a variety of combinations using solids, liquids, and gases. We also know that solutions have constant compositions, which can be varied to a point. Not all combinations, however, form solutions. Why is it that oil and water will not form a solution, but vinegar and water will? Why can table salt be dissolved in water but not in vegetable oil? The reasons why solutions form will be explored in this lesson, along with a discussion of why water is used most frequently to dissolve substances of various types.

Compound Structure and Solution Formation

Recall that a polar molecule is one that has a partially positive end and a partially negative end, while non-polar molecules have charges that are evenly distributed throughout the molecule. In fact, during the study of the Valence Shell Electron Pair Repulsion Theory (VSEPR) (from the chapter on “Covalent Bonds and Formulas”), you learned that the chemical structures themselves have built in molecular polarity.

In solution chemistry, we can predict when solutions will form using the saying, “like dissolves like.” This expression means that solubility is based on the two parts of a solution having similar intermolecular forces. For example,

suppose you are dissolving methanol in water. Both methanol and water are polar molecules that can form a solution because they both have permanent dipoles (partially positive and partially negative parts of the molecules) that allow the molecules of both substances to be attracted to the other. We say these substances are **miscible**, which means these two can dissolve in each other and make a solution. If they are **immiscible**, they are unable to be mixed together.

The same is true for the case of a non-polar substance such as carbon tetrachloride being dissolved in another non-polar substance like pentane. London-dispersion forces are the intermolecular forces that hold the carbon tetrachloride together as a liquid and allow pentane to be a liquid at room temperature. Since both of these substances have the same intermolecular forces, when they are mixed together, a solution will be formed.

In a polar solvent, the molecules of solvent are attracted to each other by the partial charges on the ends of the molecules. When a polar solute is added, the positive polar ends of the solute molecules attract the negative polar ends of the solvent molecules and vice versa. This attraction allows the two different types of molecules to form a solution. If a non-polar solute is added to a polar solvent, the non-polar solute molecules are unable to disrupt the solvent molecules. The polarity of the solvent molecules make the solvent molecules more attracted to each other rather than to the non-polar solute. As a result, the solute and solvent are immiscible. For example, if we were to add table salt, NaCl, to either carbon tetrachloride, we would find that the salt would not dissolve. Since carbon tetrachloride has no permanent dipoles in its molecules, there is no attraction among the charged ions in NaCl and the uncharged molecules of the solvent.

Water is often referred to as the “universal solvent.” The term “universal” is used to describe the fact that water can dissolve many types and kinds of substances. For instance, table salt, NaCl, is an ionic compound, but it easily makes a solution with water. This is true for many ionic compounds. Water also readily dissolves table sugar, a polar covalent compound, and other polar compounds, such as vinegar and corn syrup. Even some non-polar substances dissolve in water to a limited degree. Oxygen gas, a non-polar molecule, can dissolve in water and be taken up by fish through their gills. Carbon dioxide, another non-polar gas, is also soluble in water. Many drinks, such as sodas, beers, seltzer water, and champagne contain carbon dioxide. To keep as much gas in solution as possible, the sodas are kept under pressure.

A student defines solute and solvent and this animation shows the hydrolysis involved in dissolving (6a, 6b): <http://www.youtube.com/watch?v=hydUVGUByvU> (1:38).

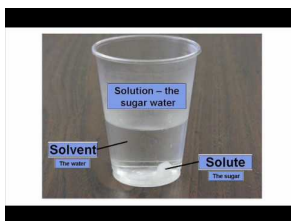

MEDIA

Click image to the left for more content.

Ionic Compounds in Solution

When a solid is formed between a metal and a nonmetal, the ions in the solid are held together by the attraction of the positive metal cation to the negative nonmetal anion. The attraction of oppositely charged particles is called electrostatic attraction (refer to the chapter “Ionic Bonds and Formulas” for more information). For example:

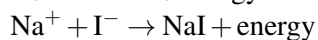
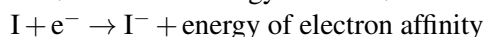
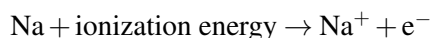

NaI is therefore held together by electrostatic attraction

Electrostatic attraction is quite strong, so compounds with this type of bonding have high melting and boiling points. Recall that ionic compounds do not form molecules. Instead, the empirical formula represents the lowest whole number ratio of the ions involved in the compound.

Example:

Which of the compounds below would contain an electrostatic attraction as bonds between ions?

1. MgCl_2
2. Al_2O_3
3. CH_4

Solution:

MgCl_2 and Al_2O_3 would contain electrostatic attraction because they are both ionic, but CH_4 is not. It does not form bonds by the transfer of electrons but instead by sharing electrons, so it does not have ions for electrostatic attraction.

Since ionic compounds can dissolve in polar solutions, specifically water, we can extend this concept to say that ions themselves are attracted to the water molecules because the ions are attracted to the polar water molecule. When you dissolve table salt in a cup of water, the table salt dissociates into sodium ions and chloride ions, as seen in the equation below:

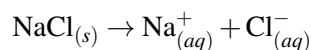

The sodium ions get attracted to the partially negative ends of the water molecule, and the chloride ions get attracted to the partially positive end of the water molecule. The process of water molecules attaching to ions is called **hydration**, as seen in the figures below.

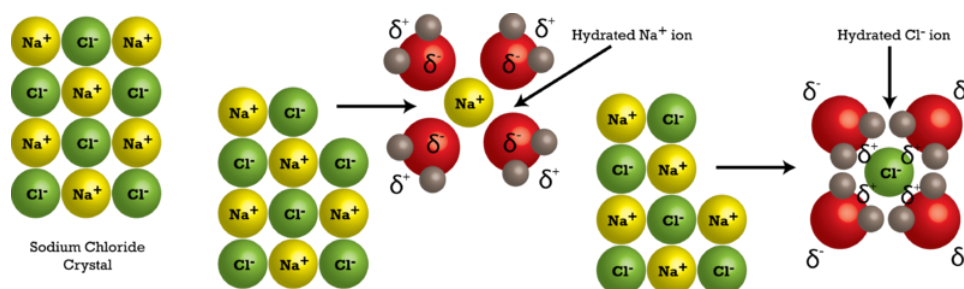

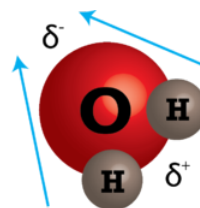
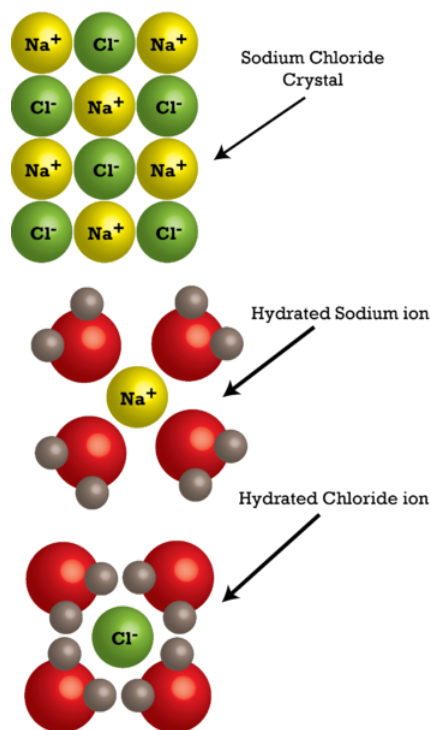

The more electronegative oxygen atom pulls the shared electrons away from the hydrogen atoms causing an unequal distribution of electrons over the water molecule. The hydrogen end of the water molecule will be slightly positive and the oxygen end will be slightly negative. A molecule with this permanent uneven distribution of electrons is said to be polar.

When a polar or ionic compound is introduced into water, ionic charges on the ions or the poles on a polar molecule are attracted to the poles on the water molecule and the substance dissolves.

The same is true for any ionic compound dissolving in water. The ionic compound will separate into positive and negative ions, and the positive ion will be attracted to the partially negative end of the water molecules (oxygen) while the negative ion will be attracted to the partially positive end of the water molecules (hydrogen).

This animation shows dissociation of salt in water creating sodium chloride solution (2c): <http://www.youtube.com/watch?v=EBfGcTAJF4o> (0:53).

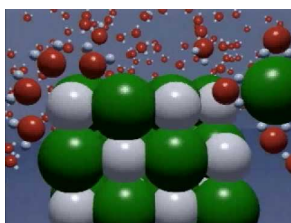

MEDIA

Click image to the left for more content.

Covalent Compounds in Solution

Covalent compounds have a different type of attraction occurring between the solute and solvent molecules. Unlike ionic compounds, which result from the transfer of electrons, covalent compounds result from the sharing of electrons between atoms. As a result, there are no distinct charges associated with the atoms in covalent compounds.

In CO_2 , each oxygen atom shares two of its electrons with carbon and the carbon shares two of its electrons with each oxygen atom. Look at the figure below:

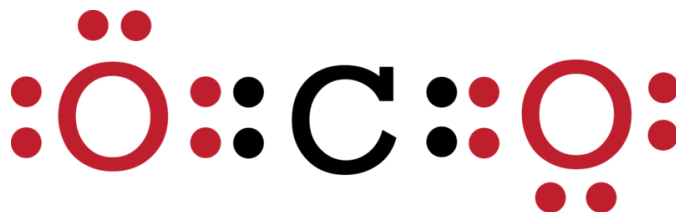

This sharing of valence electrons represents covalent bonding. However, the electrons are not shared equally. Recall that elements with a greater electronegativity have a stronger attraction for shared electrons. Therefore, they can pull the electrons closer to themselves and away from the element that has a smaller electronegativity. For carbon, the electronegativity value is 2.5, and for oxygen it is 3.5. The result in this molecule is that the electrons are pulled closer to oxygen than carbon. The resultant structure is represented below.

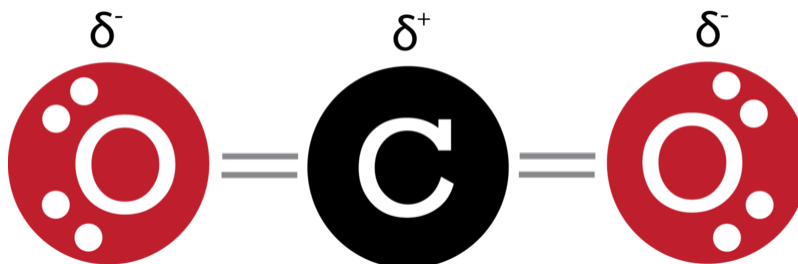

The bonds in this molecule are polar, but the molecule is non-polar overall because the shifting of the shared electrons toward the oxygen atoms are in equal but opposite directions. As a result, there is no overall dipole moment on the molecule.

As ionic solids dissolve into solution, these solids separate into ions. Molecular compounds, however, are held together with covalent bonds, which are not readily broken. For example, when you dissolve a spoonful of sugar into a glass of water, the intermolecular forces between the sugar molecules are disrupted but the intramolecular bonds are not. The sugar will not separate into carbon ions, hydrogen ions, and oxygen ions. The sugar molecules remain intact, but because of their polar properties, they can interact with the polar water molecules to form a solution. You can write the following equation for the dissolution of sugar in water:

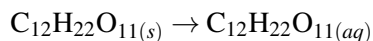

Example:

Which compounds will dissolve in solution to separate into ions?

1. LiF
2. P₂F₅
3. C₂H₅OH

Solution:

LiF will separate into ions when dissolved in solution:

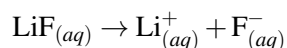

P₂F₅ and C₂H₅OH are both covalent and will stay as molecules in a solution.

Electrolytes and Non-Electrolytes

In the late 1800s, Arrhenius classified ionic compounds that dissolved in water as **electrolytes**. They are considered to be electrolytes because they conduct electricity in water solution. According to Arrhenius (and current theory), the ions in solution provide the charged particles needed to conduct electricity. Look at the equation below for the dissociation of NaCl.

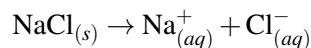

Once the solid NaCl is added to the water, it dissolves, which means that the ions move away from their crystalline structure and are now dispersed throughout the water molecules. If two electrodes were to be immersed into a solution of $\text{NaCl}_{(aq)}$, the $\text{Na}_{(aq)}^{+}$ ions would move toward one electrode and the $\text{Cl}_{(aq)}^{-}$ ions would move toward the second electrode. This movement of ions allows the electric current to flow through the solution. Therefore, $\text{NaCl}_{(aq)}$ will behave as an electrolyte and conduct electricity because of the presence of $\text{Na}_{(aq)}^{+}$ and $\text{Cl}_{(aq)}^{-}$ ions. The more ions that are present in the solution, the stronger the electrolyte solution is.

Example:

Which of the following will form electrolyte solutions and conduct electricity?

1. $\text{CaF}_{2(aq)}$
2. $\text{C}_6\text{H}_{12}\text{O}_{6(aq)}$
3. $\text{KOH}_{(aq)}$

Solution:

$\text{CaF}_{2(aq)}$ and $\text{KOH}_{(aq)}$ are solutions that contain positive cations and negative anions that would separate when dissolved in water. Since ions are separated in solution, they are electrolytes and will conduct electricity.

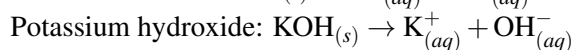
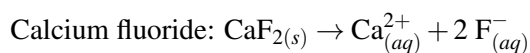

2. is not an ionic compound but a covalent compound. This means that when it dissolves in water it stays together as a molecule and is a non-electrolyte.

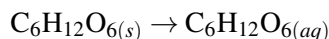

Conduction is the result of ions moving through a solution. With covalent compounds, there are no ions moving around in solution; therefore, they are classified as non-electrolytes. **Non-electrolytes** are solutions that do not conduct electricity. If you were to connect a conductivity meter to these solutions, there would be no reading the wires were placed in a solution containing a non-electrolyte.

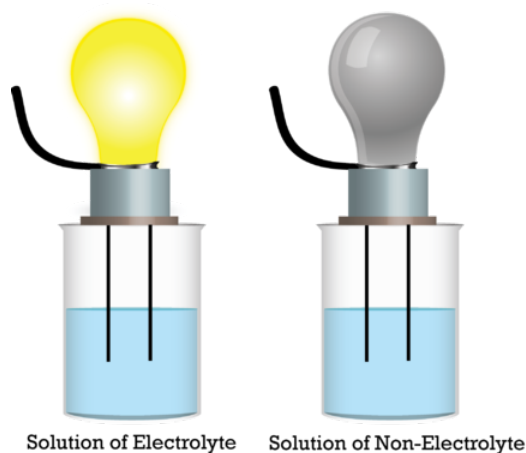

A conductivity apparatus is an incomplete electrical circuit that contains a source of electricity and a light bulb or meter that will show when current is flowing through the circuit. The ends of the incomplete circuit are prongs that can be lowered into a solution. If the prongs are lowered into a solution containing a sufficient number of ions, the circuit will be completed by the solution, current will flow, and the light bulb will light up. If the prongs are lowered into a solution with no ions or an insufficient number of ions, not enough current will flow to light the bulb.

In summary, the types of combinations that will form solutions are listed in **Table 17.3**.

TABLE 17.3: Combinations that Form Solutions

Combination	Solution Formed?
Polar substance in a polar substance.	Yes
Non-polar substance in a non-polar substance.	Yes
Polar substance in a non-polar substance.	No
Non-polar substance in a polar substance.	No
Ionic substance in a polar substance.	Yes
Ionic substance in a non-polar substance.	No

Lesson Summary

- Whether or not solutions are formed depends on the similarity of polarity or the “like dissolves like” rule.
- Polar molecules dissolve in polar solvents, non-polar molecules dissolve in non-polar solvents.
- Ionic compounds dissolve in polar solvents, especially water. This occurs when the positive cation from the ionic solid is attracted to the negative end of the water molecule (oxygen) and the negative anion of the ionic solid is attracted to the positive end of the water molecule (hydrogen).
- Water is considered as the universal solvent since it can dissolve both ionic and polar solutes, as well as some non-polar solutes (in very limited amounts).
- Electrolyte solutions are ones in which free-moving charged particles can conduct an electrical current.
- Non-electrolytes are solutions that do not conduct electricity.

Further Reading / Supplemental Links

Visit the website for a presentation on solutions.

- http://www.public.asu.edu/~jpbirk/CHM-113_BLB/Chpt13/sld002.htm

Review Questions

1. What is the “like dissolves like” generalization and provide an example to illustrate your answer.
2. Why will LiCl not dissolve in CCl₄?
3. Will acetic acid dissolve in water? Why?
4. What is the difference between intermolecular and intramolecular bonds?
5. In which compound will benzene (C₆H₆) dissolve?
 - a. carbon tetrachloride
 - b. water
 - c. vinegar
 - d. none of the above
6. In which compound will sodium chloride dissolve?
 - a. carbon tetrachloride
 - b. methanol
 - c. vinegar
 - d. none of the above

7. In which compound will ammonium phosphate dissolve?
 - a. carbon tetrachloride
 - b. water
 - c. methanol
 - d. none of the above
8. Thomas is making a salad dressing for supper using balsamic vinegar and oil. He shakes and shakes the mixture but cannot seem to get the two to dissolve. Explain to Thomas why they will not dissolve.
9. Write the reactions for dissolving the following.
 - a. $\text{NaOH}_{(s)}$
 - b. $\text{LiOH}_{(s)}$
 - c. $\text{C}_5\text{H}_{10}\text{O}_{4(s)}$
 - d. $\text{NH}_4\text{Cl}_{(s)}$
 - e. $\text{MgCl}_2_{(s)}$
10. Which of the following represent physical changes? Explain.
 - a. explosion of TNT
 - b. dissolving KCl
 - c. sharpening a pencil
 - d. souring milk
11. Which compound contains electrostatic forces?
 - a. natural gas
 - b. table salt
 - c. air
 - d. sugar
12. Which of the following is a physical change?
 - a. rotting wood
 - b. rising of bread dough
 - c. rusting iron
 - d. molding cheese
13. Which of the following is not a physical change?
 - a. melting iron
 - b. pumping gas
 - c. reaction of chlorine with sodium
 - d. reaction of magnesium chloride with water
14. Which compound is considered to be an electrolyte when dissolved in water?
 - a. HNO_3
 - b. $\text{C}_{12}\text{H}_{22}\text{O}_{11}$
 - c. N_2O
 - d. CH_4
15. Which compound is not considered to be an electrolyte?
 - a. AgCl
 - b. PbSO_4
 - c. C_2H_6
 - d. HClO_3
16. Janet is given three solutions. She is to determine if the solutions are electrolytes or not but is not told what the solutions are. She makes the following observations. What can you conclude from her observations and what help can you offer Janet to determine if the solutions are indeed electrolytes?

Solution 1: Clear

Solution 2: Blue but transparent

Solution 3: Clear

17. Describe the intermolecular bonding that would occur between glucose, $C_6H_{12}O_6$, and water.
18. Define non-electrolyte and give at least one example.
19. How can you tell by looking at a formula that it is most likely a covalent compound? What does this tell you about the bonding?
20. Describe how you could tell the difference between an electrolyte and a non-electrolyte solution.
21. Looking at the periodic table, which pair of elements will form a compound that is covalent?
 - a. Ca and Br
 - b. Fe and O
 - c. Si and F
 - d. Co and Cl
22. Which of the following compounds will conduct the least amount of electricity if dissolved in water?
 - a. KNO_3
 - b. $BaCl_2$
 - c. CsF
 - d. CO_2
23. Steve is given five solutions in the lab to identify. He performs a conductivity test, a solubility (in water) test, crudely measures the hardness of each substance, and determines the melting point using a melting point apparatus. Some of the melting points, the teacher tells him are too high or low to measure using the laboratory melting point apparatus so she gives him the melting point. For the liquids, he determined the boiling points. He gathers all of his data and puts it into a table. His teacher gives him the names of the five solutions to match his five unknowns to. Can you help Steve match the properties of the unknowns (from **Table 17.4**) to the solution names (found under the table)?

TABLE 17.4: Table for Problem 23

Unknown substance	Sub-stance	Conductivity	Solubility (in water)	Hardness	Melting Point ($^{\circ}C$)	Boiling Point ($^{\circ}C$)
1		no (aq)	soluble	semi- brittle	164	
2		yes (aq)	soluble	NA(liquid)		100
3		yes (aq)	soluble	brittle	≈ 800	
4		no (s)	insoluble	soft	82	
5		yes (s)	soluble	NA(liquid)		118

List of Unknown Names:

- Sodium chloride
- Naphthalene
- Sucrose
- Hydrochloric acid (dilute)
- Acetic acid

24. Predict the type of bonding that will form between the elements sulfur and bromine. Will this molecule conduct electricity in water solution?

17.3 Measuring Concentration

Lesson Objectives

The student will:

- define the terms concentrated and dilute.
- define concentration and list the common units used to express the concentration of solutions.
- define molarity, mass percent, ppm, and molality.
- write the formula for molarity and use the formula to perform calculations involving the molarity, moles of solute, and volume of a solution.
- calculate mass percent, ppm, molality, and mole fraction.

Vocabulary

- concentrated
- concentration
- dilute
- mass percent
- molality
- molarity
- parts per million

Introduction

Concentration is the measure of how much a given substance is mixed with another substance. Solutions can be said to be dilute or concentrated. A **concentrated** solution is one in which there is a large amount of solute in a given amount of solvent. A **dilute** solution is one in which there is a small amount of solute in a given amount of solvent. A dilute solution is a concentrated solution that has been, in essence, watered down. Think of the frozen juice containers you buy in the grocery store. In order to make juice, you mix the frozen juice from inside these containers with about 3 or 4 times the amount of water. Therefore, you are diluting the concentrated juice. The terms “concentrated” and “dilute,” however, only provide a qualitative way of describing concentration. In this lesson, we will explore some quantitative methods of expressing solution concentration.

Molarity

Of all the quantitative measures of concentration, **molarity** is the one used most frequently by chemists. Molarity is defined as the number of moles of solute per liter of solution. The symbol given for molarity is M, or moles/liter.

Chemists also use square brackets to indicate a reference to the molarity of a substance. For example, the expression $[\text{Ag}^+]$ refers to the molarity of the silver ion.

$$\text{molarity} = \text{mol/L} = \frac{\text{moles of solute}}{\text{liters of solution}}$$

Example:

What is the concentration, in mol/L, when 2.34 mol of NaCl has been dissolved in 500. mL of H₂O?

Solution:

$$[\text{NaCl}] = \frac{2.34 \text{ mol}}{0.500 \text{ liter}} = 4.68 \text{ M}$$

The concentration of the NaCl solution is 4.68 mol/L.

Example:

What would be the mass of potassium sulfate in 500. mL of a 1.25 mol/L potassium sulfate solution?

Solution:

$$\begin{aligned} M &= \frac{\text{mol}}{\text{L}}, \text{ so mol} = M \times L \\ (1.25 \text{ mol/L})(0.500 \text{ L}) &= 0.625 \text{ mol} \\ \text{mol} &= \frac{\text{mass}}{\text{molar mass}} \\ \text{so mass} &= (\text{mol}) \cdot (\text{molar mass}) \\ \text{mass} &= (0.625 \text{ mol})(174.3 \text{ g/mol}) = 109 \text{ g} \end{aligned}$$

Therefore, the mass of the K₂SO₄ that dissolves in 500. mL of H₂O to make this solution is 109 g.

Mass Percent

Mass percent is the number of grams of the solute in the number of grams of solution. Mass percent is a term frequently used when referring to solid solutions. It has the formula:

$$\text{percent by mass} = \frac{\text{mass of solute}}{\text{solute mass} + \text{solvent mass}} \times 100\%$$

or

$$\text{percent by mass} = \frac{\text{mass solute}}{\text{mass solution}} \times 100\%$$

Example:

An alloy is prepared by adding 15 g of zinc to 65 g of copper. What is the mass percent of zinc?

Solution:

$$\text{percent by mass} = \frac{\text{mass solute}}{\text{mass solution}} \times 100\% = \frac{15 \text{ g}}{80. \text{ g}} \times 100\% = 19\%$$

Parts Per Million

Parts per million is another unit for concentration. Parts per million denotes that there is 1 milligram of solute for every kilogram of solvent. It is used most frequently when dealing with environmental issues. You may have heard about parts per million when scientists are referring to drinking water or poisons in fish and other food products. To calculate parts per million, the following formula is used.

$$\text{ppm} = \frac{\text{mass of solute}}{\text{mass of solution}} \times 10^6$$

Example:

Mercury levels in fish have often been at the forefront of the news for people who love to eat fresh fish. Salmon, for instance, contains 0.01 ppm compared to shark which contains 0.99 ppm. In the United States, canned tuna is the most popular selling fish and has a mercury level of 0.12 ppm, according to the FDA statistics. If one were to consume 1.00 kg of canned tuna over a certain time period, how much mercury would be consumed?

Solution:

$$\begin{aligned} \text{ppm} &= \frac{\text{mass of solute}}{\text{mass of solution}} \times 10^6 \\ \text{mass of solute} &= \frac{(\text{mass of solution})(\text{ppm})}{1 \times 10^6} \\ \text{mass of solute} &= \frac{(1000. \text{ g})(0.12)}{1 \times 10^6} = 1.2 \times 10^{-4} \text{ g} \end{aligned}$$

Molality

Molality is another way to measure concentration of a solution. It is calculated by dividing the number of moles of solute by the number of kilograms of solvent. Molality has the symbol m.

$$\text{molality (m)} = \frac{\text{mol of solute}}{\text{kg of solvent}}$$

Molarity, if you recall, is the number of moles of solute per volume of solution. Volume is temperature dependent. As the temperature rises, the molarity of the solution will actually decrease slightly because the volume will increase slightly. Molality does not involve volume, and mass is not temperature dependent. Thus, there is a slight advantage to using molality over molarity when temperatures move away from standard conditions.

Example:

Calculate the molality of a solution of hydrochloric acid where 12.5 g of hydrochloric acid has been dissolved in 115 g of water.

Solution:

$$\begin{aligned} \text{mol HCl} &= \frac{12.5 \text{ g}}{36.46 \text{ g/mol}} = 0.343 \text{ mol} \\ \text{molality HCl} &= \frac{\text{mol solute}}{\text{kg solvent}} = \frac{0.343 \text{ mol}}{0.115 \text{ kg}} = 2.98 \text{ m} \end{aligned}$$

Here is a video of a teacher writing on an electronic blackboard. It shows how to calculate molarity, molality, and mole fraction (**6d**): <http://www.youtube.com/watch?v=9br3XBjFszs> (7:36).

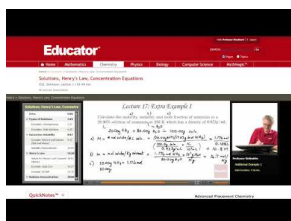

MEDIA

Click image to the left for more content.

Lesson Summary

- Concentration is the measure of how much of a given substance is mixed with another substance.

- Molarity is the number of moles of solute per liter of solution.
- Mass percent is the number of grams of the solute in the number of grams of solution, multiplied by 100%.
- Parts per million means that there is 1 milligram of solute for every kilogram of solvent. Therefore, it is the mass of solute per mass of solution multiplied by 1 million.
- Molality is calculated by dividing the number of moles of solute by the kilograms of solvent. It is less common than molarity but more accurate because of its lack of dependence on temperature.

Review Questions

1. Calculate the mass percent of silver when a silver/nickel solution is made with 34.5 g of silver and 72.3 g of nickel.
2. What would be the ppm of silver for the data presented in question 1?
3. Why is it a good idea to learn mass percent when molarity and molality are the most commonly used concentration measures?
4. Most times when news reports indicate the amount of lead or mercury found in foods, they use the concentration measures of ppb (parts per billion) or ppm (parts per million). Why use these over the others we have learned?
5. What is the molarity of a solution prepared by dissolving 2.5 g of LiNO_3 in sufficient water to make 60. mL of solution?
 - a. 0.036 mol/L
 - b. 0.041 mol/L
 - c. 0.60 mol/L
 - d. 0.060 mol/L
6. A solution is known to have a concentration of 325 ppm. What is the mass of the solute dissolved in 1.50 kg of solvent?
 - a. 0.32 mg
 - b. 0.49 mg
 - c. 325 mg
 - d. 488 mg
7. Calculate the molality of a solution of copper(II) sulfate where 11.25 g of the crystals has been dissolved in 325 g of water.
 - a. 0.0346 m
 - b. 0.0705 m
 - c. 0.216 m
 - d. None of the above.
8. What is the mass of magnesium chloride present in a 250 g solution found to be 21.4% MgCl_2 ?
 - a. 21.4 g
 - b. 53.5 g
 - c. 196.5 g
 - d. 250 g
9. What is the concentration of each of the following solutions in mol/L?
 - a. 3.50 g of potassium chromate dissolved in 100 mL of water
 - b. 50.0 g of magnesium nitrate dissolved in 250 mL of water.
 - c. Find the mass of aluminum nitrate required to produce 750 g of a 1.5 molal solution.
10. The Dead Sea contains approximately 332 grams of salt per kilogram of seawater. Assume this salt is all NaCl. Given that the density of the Dead Sea water is approximately 1.20 g/mL, calculate:

- a. the mass percent of NaCl.
- b. the mole fraction of NaCl.
- c. the molarity of NaCl.

17.4 Factors Affecting Solubility

Lesson Objectives

The student will:

- define the terms soluble, insoluble, and solubility.
- describe the factors that affect solid solubility.
- describe the factors that affect gas solubility.
- describe how pressure can affect solubility.
- explain the effect of temperature on the solubility of a solid solute in a liquid solvent.
- explain the effect of pressure on the solubility of a gaseous solute in a liquid solvent.
- state Henry's law.

Vocabulary

- Henry's law
- insoluble
- solubility
- soluble

Introduction

Take some sand and try to dissolve it in a cup of water. What happens? The sand will not dissolve; in other words, it is insoluble. **Insoluble** means that the substance does not dissolve. If you were to take a teaspoon of table salt or sugar and conduct the same experiment, the result would be different. Salt and sugar are both soluble in water. When a substance is **soluble**, it means that the substance has the ability to dissolve in another substance.

Solubility is the maximum amount of a substance that will dissolve in a given amount of solvent at a specific temperature. There are two direct factors that affect solubility: temperature and pressure. Temperature affects the solubility of both solids and gases, but pressure only affects the solubility of gases. Surface area does not affect how much of a solute will be dissolved, but it is a factor in how quickly or slowly the substance will dissolve. In this section, we will explore all three of these factors and how they affect the solubility of solids and gases.

The Effect of Temperature on Solubility

Temperature has a direct effect on solubility. For the majority of ionic solids, increasing the temperature increases how quickly the solution can be made. As the temperature increases, the particles of the solid move faster, which

increases the chances that they will interact with more of the solvent particles. This results in increasing the rate at which a solution occurs.

Temperature can also increase the amount of solute that can be dissolved in a solvent. Generally speaking, as the temperature is increased, more solute particles will be dissolved. For instance, when you add table sugar to water, a solution is quite easily made. When you heat that solution and keep adding sugar, you find that large amounts of sugar can be added as the temperature keeps rising. The reason this occurs is because as the temperature increases, the intermolecular forces can be more easily broken, allowing more of the solute particles to be attracted to the solvent particles. There are other examples, though, where increasing the temperature has very little effect on how much solute can be dissolved. Table salt is a good example: you can dissolve just about the same amount of table salt in ice water as you can in boiling water.

For all gases, as the temperature increases, the solubility decreases. The kinetic molecular theory can be used to explain this phenomenon. As the temperature increases, the gas molecules move faster and are then able to escape from the liquid. The solubility of the gas, then, decreases.

Looking at the graph below, ammonia gas, NH_3 , shows a sharp decline in solubility as the temperature increases, whereas all of the ionic solids show an increase in solubility as the temperature increases.

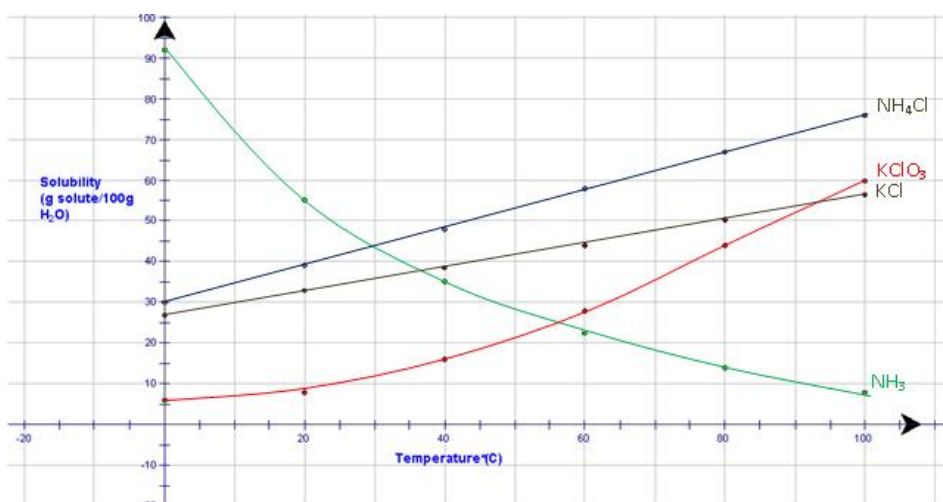

A graph for the solubility of oxygen gas, O_2 , would be very similar to the one for $\text{NH}_3(g)$; in other words, oxygen gas would decrease in solubility as the temperature rises. Conversely, the colder the temperature, the greater amount of $\text{O}_2(g)$ would be dissolved.

The Effect of Pressure on Solubility

The second factor, pressure, affects the solubility of a gas in a liquid but never of a solid dissolving in a liquid. When pressure is applied to a gas that is above the surface of a solvent, the gas will move into the solvent and occupy some of the spaces between the particles of the solvent. A good example is carbonated soda. Pressure is applied to force the CO_2 molecules into the soda. The opposite is also true. When the gas pressure is decreased, the solubility of that gas is also decreased. When you open a can of carbonated beverage, the pressure in the soda is lowered, so the gas immediately starts leaving the solution. The carbon dioxide stored in the soda is released, and you can see the fizzing on the surface of the liquid. If you leave an open can of soda out for a period of time, you may notice the beverage becoming flat because of the loss of carbon dioxide.

This gas pressure factor is expressed in **Henry's law**. Henry's law states that, at a given temperature, the solubility of a gas in a liquid is proportional to the partial pressure of the gas above the liquid. An example of Henry's Law

occurs in scuba diving. As a person dives into deep water, the pressure increases and more gases are dissolved into the blood. While ascending from a deep-water dive, the diver needs to return to the surface of the water at a very slow rate to allow for all of the dissolved gases to come out of the blood very slowly. If a person ascends too quickly, a medical emergency may occur due to the gases coming out of blood too quickly. This is called having the “bends.”

This video serves a blackboard lecture on the factors that affect solubility (6c): <http://www.youtube.com/watch?v=1Hbkco6hyJ4> (4:33).

Molecule Size

• Generally, the smaller the molecule, the more soluble it is.

size decreases

Name of Compound	methanol	ethanol	propanol	butanol	pentanol
Chemical Formula	CH_3OH	$\text{CH}_3\text{CH}_2\text{OH}$	$\text{CH}_3\text{CH}_2\text{CH}_2\text{OH}$	$\text{CH}_3\text{CH}_2\text{CH}_2\text{CH}_2\text{OH}$	$\text{CH}_3\text{CH}_2\text{CH}_2\text{CH}_2\text{CH}_2\text{OH}$
Relative Solubility	infinitely soluble	infinitely soluble	very soluble	sol. 1000ml at 22°C	sol. 100ml at 22°C

MEDIA

Click image to the left for more content.

The Effect of Surface Area on the Rate of Dissolving

One other factor to consider affects the rate of solubility. If we were to increase the surface area of a solid, then it would have been broken into smaller pieces. We would do this to increase how quickly the solute would dissolve in solution. If you were to dissolve sugar in water, a sugar cube will dissolve slower than an equal amount of tiny pieces of sugar crystals. The combined surface area of all of the sugar crystals have a much greater surface area than the one sugar cube and will have more contact with the water molecules. This allows the sugar crystals to dissolve much more quickly.

If you were working in a lab, you might be asked to make a solution of copper(II) sulfate. Copper(II) sulfate comes in several forms: large blue crystals and fine blue crystals (see **Figure 17.1**). When you set equal amounts of both forms in test tubes filled with 10 mL of water, you will notice after 5 minutes that more of the fine crystals will have dissolved (and the solution will be a darker blue) than the test tube with the large crystals. You can also take two samples of the fine crystals and put them into separate test tubes. This time, place a stopper on one of the test tubes and carefully shake it while letting the other test tube sit still. By shaking, you are again increasing the surface area by increasing the how much of the fine crystals will come in contact with the water. The result will still be the same as before: the test tube with the greater surface area will go into solution at a faster rate. Note, however, that although maximum solubility is achieved more quickly with greater surface area, the concentration of the solute at maximum solubility will be exactly the same.

crystalline copper (II) sulfate

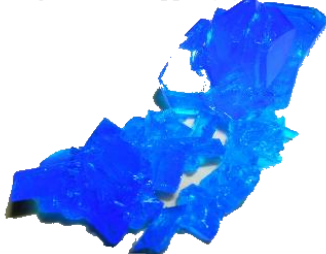

powdered copper (II) sulfate



FIGURE 17.1

Forms of copper(II) sulfate pentahydrate.

Lesson Summary

- When a substance can dissolve in another it is said to be soluble; when it cannot, it is said to be insoluble
- Temperature affects the solubility of both gases and solids. With solids, generally the solubility increases with increasing temperature. With gases, the solubility tends to decrease with increasing temperature.
- Pressure only affects the solubility of gases. Henry's law states that, at a given temperature, the solubility of a gas in a liquid is proportional to the partial pressure of the gas above the liquid.
- Increasing the surface area increases the rate of solubility of a solid because a larger number of molecules have contact with the solvent.

Review Questions

1. What are the factors that affect solubility?
2. What is Henry's law?
3. Is it ever possible to have ionic solids decrease solubility with increasing temperature?

Consider the following factors for problems 4-5.

- i. temperature
- ii. pressure
- iii. surface area

4. Which of the factors listed above would affect the solubility of sodium sulfate?
 - a. i, ii, and iii
 - b. i and ii
 - c. i and iii
 - d. ii and iii
5. Which of the factors listed above would affect the solubility of methane?
 - a. i, ii, and iii
 - b. i and ii
 - c. i and iii
 - d. ii and iii
6. If you crush a cube a sugar before putting it in your cup of coffee, how have you affected its solubility?
 - a. Crushing it has really no affect on solubility because we have not heated it at all.
 - b. Crushing it has increased the surface area so it speeds up the dissolving process but doesn't change maximum solubility.
 - c. Crushing it has really no affect on solubility because we have not stirred it at all.
 - d. Crushing it has increased the surface area so it increases the maximum solubility.
7. Why do people add chlorine to their swimming pools on a hot day?
8. Explain why crushed table salt at room temperature dissolves faster than rock salt.
9. Under which of the following sets of conditions would the solubility of $\text{CO}_{2(g)}$ be lowest? The pressure given is the pressure of $\text{CO}_{2(g)}$ above the solution.
 - a. 5.0 atm and 75°C
 - b. 1.0 atm and 75°C
 - c. 5.0 atm and 25°C

- d. 1.0 atm and 25°C
 - e. 3.0 atm and 25°C
10. An aqueous solution of KCl is heat from 15°C to 85°C. Which of the following properties of the solution remain the same: i. molality, ii. molarity, iii. density?
- a. i only
 - b. iii only
 - c. i and ii only
 - d. ii and iii only
 - e. i, ii, and iii

17.5 Solubility Graphs

Lesson Objectives

The student will:

- define unsaturated solution and saturated solution.
- interpret a solubility graph in terms of temperature and saturation points.

Vocabulary

- saturated solution
- unsaturated solution

Introduction

Solubility graphs are an excellent way of organizing and displaying data for interpretation. In this lesson, we will learn how to read and analyze a solubility graph in order to extract the relevant data.

Saturated and Unsaturated Solutions

A **saturated solution** is one in which a given amount of solvent has dissolved the absolute maximum amount of solute at that temperature. Two teaspoons of table salt in one cup of water is probably the maximum amount of salt that can be dissolved in water. If you then try to dissolve three teaspoons, some of the table salt would probably sit on the bottom of the glass. Once a solution becomes saturated, if more solute is added to a saturated solution, the excess solute remains undissolved and simply sits on the bottom of the cup. In comparison, if only one teaspoon was placed in the glass, the solution would be said to be unsaturated. An **unsaturated solution** is one that contains less than the maximum amount of solute that is possible in a given amount of solvent.

Reading and Interpreting Solubility Graphs

As we already know, solubility is the amount of solute that will dissolve in a given amount of solvent at a particular temperature. The latter part of this statement is significant since, for many solutes, the solubility will increase as the temperature is increased. There are exceptions, of course, such as sodium chloride (table salt). Sodium chloride will dissolve to the extent of about 36 g in 100 g of water at 25°C, and there is little change as the temperature increases. As another example, the solubility of cesium sulfate actually decreases as temperature increases. For the most part, however, the vast majority of ionic solids that are solutes do increase their solubility with temperature.

To display the different solubilities at different temperatures, a solubility graph is drawn to show the data in a more coherent manner. Having a solubility graph allows us to read the data about a particular solute or to compare solutes at a particular temperature quickly and easily. Let's look at a typical solubility graph and see how it works.

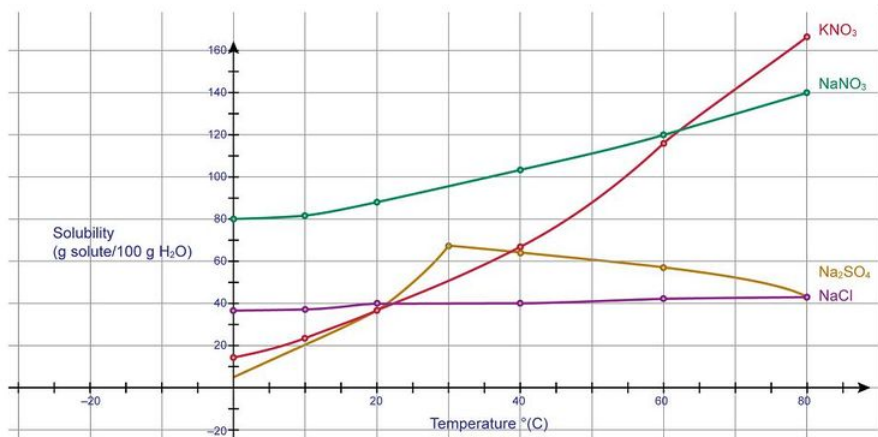

What kind of information does this graph tell us? You can see that the solubility of three of the four solids increases with increasing temperature. In addition to general trends in the solubility of a substance, you can also get detailed facts from a solubility graph. For example, we can see that at 30°C, 95 g of sodium nitrate (NaNO₃) will dissolve, but at 60°C, 120 g will dissolve in 100 g of H₂O. At these same two temperatures, only 50 g of Na₂SO₄ and 113 g of potassium nitrate (KNO₃) will dissolve in 100 g of H₂O.

Example:

Answer the following questions using the solubility graph above.

1. How much sodium nitrate will dissolve at 30°C?
2. Which solid is most soluble at 60°C?
3. Which solid is least soluble at 40°C?
4. At what temperature will 60 g of sodium sulfate dissolve in 100 g of water?

Solution:

1. Looking at the solubility graph below, you draw a line up (vertically) from 30°C until it hits the NaNO₃ line. Following this, carry the line over (horizontally) to find the amount of NaNO₃ that dissolves. Therefore, approximately 95 g of NaNO₃ will dissolve in 100 g of water at 30°C.

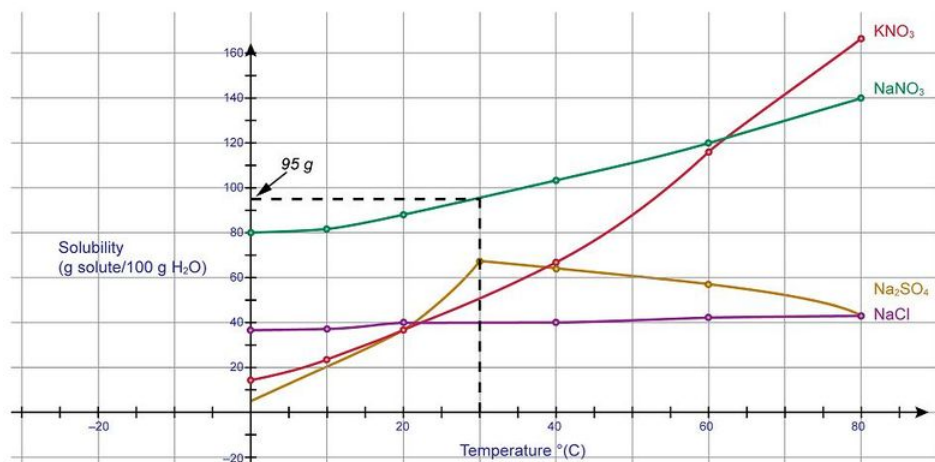

- The highest line at 60°C is the green line (NaNO₃), therefore it is the most soluble at 60°C.
- The lowest line at 40°C is the purple line (NaCl), therefore NaCl is the least soluble at 40°C.
- Looking at the solubility graph below, you draw a line over (horizontally) from 60 g until it hits the Na₂SO₄ line. Following this, carry the line down (vertically) to find the temperature at which 60 g of Na₂SO₄ will dissolve. Therefore, 60 g of Na₂SO₄ will dissolve in 100 g of water at 50°C.

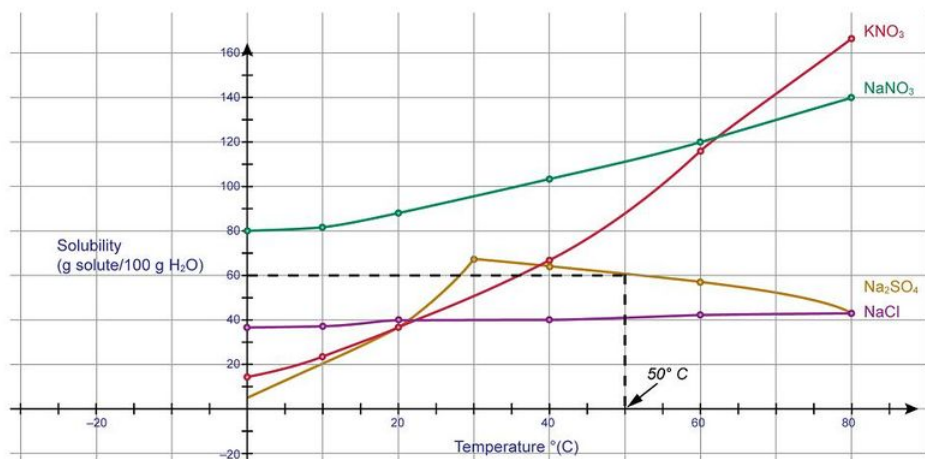

Look at the solubility graph below, which shows more common ionic compounds. The lines on the solubility curves represent the amounts that dissolve in the given amount of solvent at a specific temperature. Look at the line for NH₃. According to the graph, NH₃ is the only substance of this group that decreases in solubility as the temperature is increased. We can also see that the most soluble substance at room temperature (25°C) is NH₃ because it is the line highest up on the graph at 25°C. The highest point on the solubility curve is at approximately y = 92. We can say then that the most soluble substance at 0°C is ammonia with a solubility of approximately 92 g in 100 g of water.

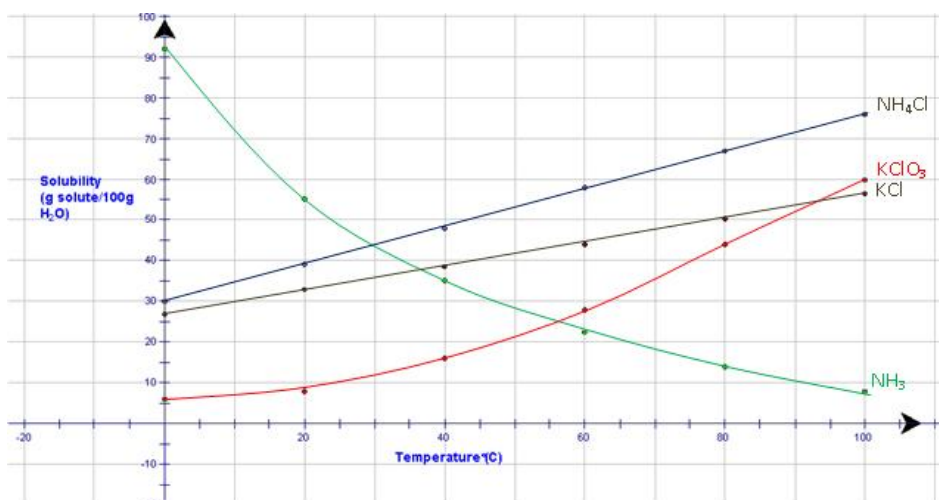

All of this information can be obtained from reading the solubility graph. What other information can you obtain from a solubility graph? You could do a number of different types of calculations. For example, if you were doing an experiment in the lab (at room temperature) and needed a saturated solution of potassium chloride dissolved in 35 g of water, how much KCl would you need?

At 25°C (room temperature), approximately 35 g of KCl will dissolve in 100. g of water. For 35 g of water:

$$\frac{x \text{ g KCl}}{35 \text{ g H}_2\text{O}} = \frac{35 \text{ g KCl}}{100. \text{ g H}_2\text{O}}$$

$$x = 12 \text{ g KCl}$$

Another type of problem that can be solved using a solubility graph is determining whether a solution is saturated or not. For example, you have a solution of potassium chlorate that you know is 76 g dissolved in 250 g of water. You want to know if this solution is saturated or unsaturated when your solution is being heated at 80°C.

Looking at the solubility graph, at 80°C, 44 g of KClO_3 will dissolve in 100. g of H_2O . Therefore, we can use the same type of equation as used previously to determine how much would dissolve in 250 g of H_2O .

$$\frac{x \text{ g KClO}_3}{250. \text{ g H}_2\text{O}} = \frac{44 \text{ g KClO}_3}{100. \text{ g H}_2\text{O}}$$
$$x = 110. \text{ g KClO}_3$$

Since it is possible to dissolve 110 g of KClO_3 in 250 g of H_2O and our solution only has 76 g dissolved in 250 g of H_2O , the solution is unsaturated.

Lesson Summary

- A saturated solution holds the maximum amount of solid at a specific temperature.
- An unsaturated solution does not have the maximum amount of solute dissolved at that temperature in a given amount of solvent.
- A solubility graph is drawn to display the solubility at different temperatures.
- From reading a solubility graph, one can determine the mass of solute that can dissolve at specific temperatures, whether or not a solution is saturated, and compare solubilities of different substances at specific temperatures.

Further Reading / Supplemental Links

This website details some of the factors that affect solubility.

- <http://www.citycollegiate.com/chapter3d.htm>

Review Questions

1. Using the graph below, determine:
 - a. How much ammonia will dissolve at 30°C?
 - b. What solid is more soluble at 50°C?
 - c. What solid is least soluble at 60°C?
 - d. At what temperature will 50 g of ammonium chloride dissolve in 100 g of water?

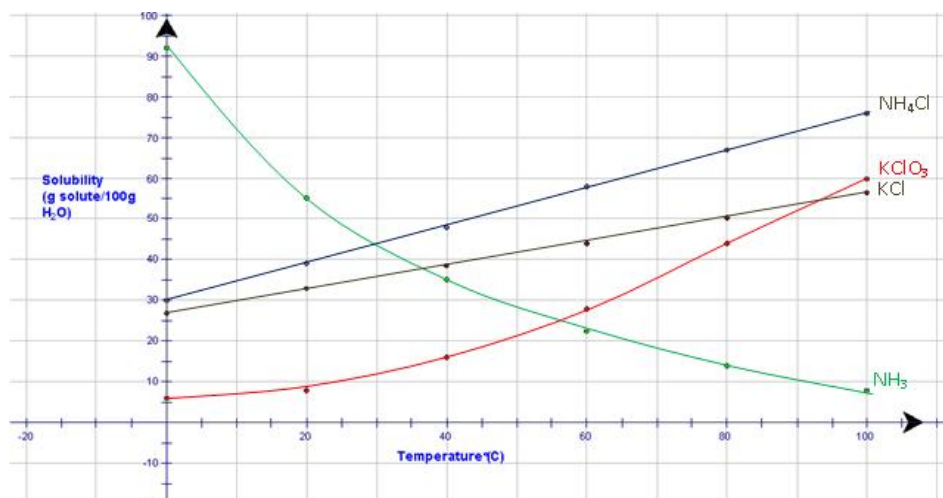

- Why are solubility graphs useful?
- Define solubility and solubility graph.
- How many grams of NaCl are in 450 g of water at 30°C if the solubility is 39.8 g per 100 g of water?
 - 8.84 g
 - 39.8 g
 - 100 g
 - 179 g
- How many moles of ammonium chloride are in 225 g of water at 40°C if the solubility is 45.8 g per 100 g of water?
 - 0.86 mol
 - 1.92 mol
 - 20.3 mol
 - 103 mol
- How many moles of potassium chloride are in 500 g of water at 80°C if the solubility is 51.3 g per 100 g of water?
 - 0.140 mol
 - 0.688 mol
 - 3.44 mol
 - 10.3 mol
- Plot the following data (see **Table 17.5**) on a solubility graph and then answer the questions below.
 - Which substance is the most soluble at 50°C?
 - Which substance is the least soluble at 90°C?
 - What is the solubility of NH₄ClO₄ at 30°C?
 - How many grams of NH₄ClO₄ would dissolve in 250 mL at 30°C?
 - At what temperature will 20 g potassium sulfate dissolve in 100 g of water?

TABLE 17.5: Table for Problem 7

Temp (°C)	g NH ₄ Br/100 g H ₂ O	g NH ₄ ClO ₄ /100 g H ₂ O	g NaClO ₃ /100 g H ₂ O
0	60.0	13.0	80.0
20	75.5	23.5	98.0
40	92.0	36.8	118.0
60	107.8	51.5	143.0
80	126.0	67.9	172.0
100	146.0	87.0	207.0

8. Plot the following data (see **Table 17.6**) on a solubility graph and then answer the questions below.
- Which substance is the most soluble at 50°C?
 - Which substance is the least soluble at 90°C?
 - What is the solubility of CuSO_4 at 30°C?
 - At what temperature will 20 g potassium sulfate dissolve in 100 g of water?

TABLE 17.6: Table for Problem 8

Temp (°C)	g NaCl/100 g H ₂ O	K ₂ SO ₄ /100 g H ₂ O	g CuSO ₄ /100 g H ₂ O
0	35.7	7.4	14.3
20	36.0	11.1	20.7
40	36.5	14.8	28.7
60	37.3	18.2	40.0
80	38.1	21.4	56.0
100	39.2	24.1	80.0

17.6 Colligative Properties

Lesson Objectives

The student will:

- explain what the term colligative means and list colligative properties.
- indicate what happens to the boiling point, the freezing point, and the vapor pressure of a solvent when a solute is added to it.
- explain why a solution has a lower vapor pressure than the pure solvent of that solution.
- explain why a solution has an elevated boiling point and a depressed freezing point.
- define the van't Hoff factor.
- calculate boiling point elevations and freezing point depressions for both non-electrolyte and electrolyte solutions.
- calculate molar masses from freezing point depression data.

Vocabulary

- boiling point elevation
- colligative property
- freezing point depression
- van't Hoff factor

Introduction

People who live in colder climates have seen the trucks put salt on the roads when snow or ice is forecast. Why do they do that? When planes fly in cold weather, the planes need to be de-iced before liftoff. Why is that done? It turns out that pure solvents differ from solutions in their boiling points and freezing points. In this lesson, you will understand why these events occur. You will also learn to calculate exactly how much of an effect a specific solute can have on the boiling point or freezing point of a solution.

Vapor Pressure Lowering

An enclosed liquid will reach vapor pressure equilibrium with its vapor in the space above the liquid. Vapor pressure equilibrium is reached when the rate of evaporation and the rate of condensation become equal. The vapor pressure depends on the temperature of the liquid, so raising the temperature increases the rate of evaporation and therefore the vapor pressure of the liquid. When the temperature of the liquid becomes high enough for the vapor pressure to equal the surrounding pressure, the liquid will boil. When the surrounding pressure is 1.00 atm, the boiling point is called the “normal” boiling point. A pure liquid solvent at normal atmospheric pressure cannot have its temperature

raised above the normal boiling point because at the normal boiling point, all of the liquid will vaporize before the temperature will increase.

In a pure solvent, all the molecules at the surface are solvent molecules. Remember that only the molecules on the surface of a liquid are able to evaporate. For the pure solvent, then, the entire surface area is available for evaporation, and the forces that need to be overcome are the attractive forces between the solvent molecules. Adding a solute to a solvent lowers the vapor pressure of the solvent. There are two equally valid explanations for why the addition of a solute lowers the vapor pressure of a solution. One explanation is that since some of the surface molecules are solute molecules, these solute molecules take up some of the surface area, making less surface area available for evaporation (see illustration below). Therefore, the rate of evaporation of the solvent will be lower, resulting in a lower vapor pressure at the same temperature. The other explanation says that the attractive forces between the solvent molecules and the solute molecules are greater than the attractive forces between solvent molecules, so the solvent molecules will not evaporate at as high a rate. Once again, the vapor pressure will be lowered.



The amount that the vapor pressure is lowered is related to the molal (m) concentration of the solute. Suppose a pure solvent has a vapor pressure of 20. mm of Hg at a given temperature. Suppose further that sufficient non-electrolyte solute is dissolved in the solvent to make a 0.20 m solution and that the vapor pressure of the solution at the same temperature is 18 mm of Hg. Then, if enough solute is dissolved to make the solution 0.40 m , the vapor pressure of the more concentrated solution will be 16 mm of Hg. There is a direct mathematical relationship between the molality of the solution and the vapor pressure lowering.

Experiments with this phenomenon demonstrate that as long as the solute is a non-electrolyte, the effect is the same regardless of what solute is used. The effect is related only to the number of particles of solute, not the chemical composition of the solute. Vapor pressure lowering is an example of a colligative property. **Colligative properties** are properties that are due only to the number of particles in solution and not to the chemical properties of the solute.

Boiling Point Elevation

The boiling point of a liquid occurs when the vapor pressure above the surface of the liquid equals the surrounding pressure. At 1 atm of pressure, pure water boils at 100°C, but salt water does not. When table salt is added to water, the resulting solution has a higher boiling point than water alone. Essentially, the solute particles take up space at the solvent/air interface, physically blocking some of the more energetic water molecules from escaping into the gas phase. This is true for any solute added to a solvent. **Boiling point elevation** is another example of a colligative property, meaning that the change in boiling point is related only to the number of solute particles in solution, regardless of what those particles are. A 0.20 m solution of table salt would have the same change in boiling point as a 0.20 m solution of KNO_3 .

Freezing Point Depression

The effect of adding a solute to a solvent has the opposite effect on the freezing point of a solution as it does on the boiling point. Recall that the freezing point is the temperature at which the liquid changes to a solid. At a given temperature, if a substance is added to a solvent (such as water), the solute-solvent interactions prevent the solvent from going into the solid phase, requiring the temperature to decrease further before the solution will solidify. A common example is found when salt is used on icy roadways. Here the salt is put on the roads so that the water on the roads will not freeze at the normal 0°C but at a lower temperature, as low as -9°C. The de-icing of planes is another common example of freezing point depression in action. A number of solutions are used, but commonly a solution such as ethylene glycol or a less toxic monopropylene glycol is used to de-ice an aircraft. The aircrafts are sprayed with the solution when the temperature is predicted to drop below the freezing point. The **freezing point depression**, then, is the difference between the freezing points of the solution and the pure solvent.

The Mathematics of Boiling Point and Freezing Point Changes

The amount to which the boiling point increases or the freezing point decreases depends on the amount solute that is added to the solvent. A mathematical equation can be used to calculate the boiling point elevation or the freezing point depression. Remember the solution has a higher boiling point, so to find the boiling point elevation you would subtract the boiling point of the solvent from the boiling point of the solution. For example, the boiling point of pure water at 1.0 atm is 100.°C, while the boiling point of a 2% salt-water solution is about 102°C. Therefore, the boiling point elevation would be 2°C. In comparison, the freezing point depression is found by subtracting the freezing point of the solution from the freezing point of the pure solvent.

Both the boiling point elevation and the freezing point depression are related to the molality of the solutions. Looking at the formulas for the boiling point elevation and freezing point depression, we can see similarities between the two.

Boiling point elevation:

$$\Delta T_b = K_b m$$

where

$$\Delta T_b = T_{\text{solution}} - T_{\text{pure solvent}}$$

K_b = boiling point elevation constant

m = molality of the solution.

Freezing point depression:

$$\Delta T_f = K_f m$$

where

$$\Delta T_f = T_{f(\text{solution})} - T_{f(\text{pure solvent})}$$

K_f = freezing point depression constant

m = molality of the solution.

The boiling point and freezing point constants are different for every solvent and are determined experimentally in the lab. You can find these constants for hundreds of solvents listed in data reference publications for chemistry and physics.

Example:

Antifreeze is used in automobile radiators to keep the coolant from freezing. In geographical areas where winter temperatures go below the freezing point of water, using pure water as the coolant could allow the water to freeze. Since water expands when it freezes, freezing coolant could crack engine blocks, radiators, and coolant lines. The main component in antifreeze is ethylene glycol, $C_2H_4(OH)_2$. If the addition of an unknown amount of ethylene glycol to 150. g of water dropped the freezing point of the solution by -1.86°C , what mass of ethylene glycol was used? The freezing point constant, K_f , for water is $-1.86^\circ\text{C}/m$.

Solution:

$$\Delta T_f = K_f m$$

$$m = \frac{\Delta T_f}{K_f} = \frac{-1.86^\circ\text{C}}{-1.86^\circ\text{C}/m} = 1.00 m$$

$$m = \frac{\text{mol solute}}{\text{kg solvent}}$$

$$\text{moles solute} = (\text{molality})(\text{kg solvent}) = (1.00 \text{ mol/kg})(0.150 \text{ kg}) = 0.150 \text{ mol}$$

$$\text{mass } C_2H_4(OH)_2 = (\text{mol})(\text{molar mass}) = (0.150 \text{ mol})(62.1 \text{ g/mol}) = 9.32 \text{ g}$$

Therefore, 9.32 g of ethylene glycol would have been added to the 150. g of water to lower the freezing point by 1.86°C .

Remember that colligative properties are due to the number of solute particles in the solution. Adding 10 molecules of sugar to a solvent will produce 10 solute particles in the solution. However, when the solute is an electrolyte, such as NaCl, adding 10 molecules of solute to the solution will produce 20 ions (solute particles) in the solution. Therefore, adding enough NaCl solute to a solvent to produce a 0.20 m solution will have twice the effect of adding enough sugar to a solvent to produce a 0.20 m solution.

The **van't Hoff factor** (i) is the number of particles that the solute will dissociate into upon mixing with the solvent. For example, sodium chloride (NaCl) will dissociate into two ions, so the van't Hoff factor for NaCl is $i = 2$. For lithium nitrate ($LiNO_3$), $i = 2$, and for calcium chloride ($CaCl_2$), $i = 3$.

We can now rewrite our colligative properties formulas to include the van't Hoff factor.

Boiling point elevation:

$$\Delta T_b = iK_b m$$

where

i = van't Hoff factor

$$\Delta T_b = T_{\text{solution}} - T_{\text{puresolvent}}$$

K_b = boiling point elevation constant

m = molality of the solution.

Freezing point depression:

$$\Delta T_f = iK_f m$$

where

i = van't Hoff factor

$$\Delta T_f = T_{f(\text{solution})} - T_{f(\text{puresolvent})}$$

K_f = freezing point depression constant

m = molality of the solution.

We can use this formula for both electrolyte and non-electrolyte solutions since the van't Hoff factor for non-electrolytes is always 1 because they do not dissociate.

Example:

A solution of 10.0 g of sodium chloride is added to 100.0 g of water in an attempt to elevate the boiling point. What is the boiling point of the solution?

Solution:

$$\Delta T_b = iK_b m$$

$$\text{mol NaCl} = \frac{\text{grams}}{\text{molar mass}} = \frac{10.0 \text{ g}}{58.5 \text{ g/mol}} = 0.171 \text{ mol}$$

$$\text{molality} = \frac{\text{mol solute}}{\text{kg solvent}} = \frac{0.171 \text{ mol}}{0.100 \text{ kg}} = 1.71 \text{ m}$$

For NaCl, $i = 2$ ($\text{NaCl} \rightarrow \text{Na}^+ + \text{Cl}^-$)

$$K_{b(\text{water})} = 0.52^\circ\text{C/m}$$

$$\Delta T_b = iK_b m$$

$$\Delta T_b = (2)(0.52^\circ\text{C/m})(1.71 \text{ m}) = 1.78^\circ\text{C}$$

$$T_{b(\text{solution})} = T_{b(\text{puresolvent})} + \Delta T_b$$

$$T_{b(\text{solution})} = 100^\circ\text{C} + 1.78^\circ\text{C} = 101.78^\circ\text{C}$$

Therefore, the boiling point of the solution of 10 g of NaCl in 100 g of water is 102°C .

This video explains the reasoning behind and the math involved in boiling point elevation and freezing point depression (6e): <http://www.youtube.com/watch?v=z9LxdqYntIU> (14:00).

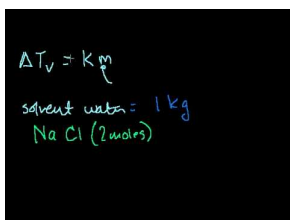

MEDIA

Click image to the left for more content.

Lesson Summary

- Colligative properties are properties that are due only to the number of particles in solution and not to the chemical properties of the solute.
- Vapor pressure lowering, boiling point elevation, and freezing point depression are colligative properties.
- The boiling point elevation can be calculated using the formula $\Delta T_b = K_b m$, where ΔT_b is the boiling point elevation, K_b is the boiling point elevation constant, and m is molality.
- The freezing point depression can be calculated using the formula $\Delta T_f = K_f m$, where ΔT_f is the freezing point depression, K_f is the freezing point depression constant, and m is molality.
- For electrolyte solutions, the van't Hoff factor is added to account for the number of ions that the solute will dissociate into in solution. For non-electrolyte solutions, the van't Hoff factor = 1. The equations change to account for this factor ($\Delta T_b = K_b m$ becomes $\Delta T_b = iK_b m$ and $\Delta T_f = K_f m$ becomes $\Delta T_f = iK_f m$, where i is the number of particles each solute molecule produces in solution.

Further Reading / Supplemental Links

The following link hosts several videos on how to solve various types of chemistry solutions problem.

- <http://www.kentchemistry.com/moviesfiles/chemguy/AP/ChemguySolutions.htm>

Review Questions

1. What must be measured in order to determine the freezing point depression?
2. From a list of solutions with similar molalities, how could you quickly determine which would have the highest boiling point?
3. Why would table salt not be a good solution to use when deicing a plane?
4. Identify which of the following statements are true. When a solute is added to a solution, i. the boiling point increases, ii. the boiling point decreases, iii. the freezing point increases, iv. the freezing point decreases.
 - a. i and iii are true
 - b. i and iv are true
 - c. ii and iii are true
 - d. ii and iv are true
5. If 25.0 g of sucrose ($C_{12}H_{22}O_{11}$) is added to 500. g of water, the boiling point is increased by what amount? ($K_b(\text{water}) = 0.52^\circ\text{C}/m$)
 - a. 0.076°
 - b. 0.025°
 - c. 26°
 - d. None of these
6. The solubility of seawater (an aqueous solution of NaCl) is approximately 0.50 m. Calculate the freezing point of seawater. ($K_f(\text{water}) = 1.86^\circ\text{C}/m$)
 - a. -0.93°
 - b. 0.93°
 - c. 1.86°
 - d. -1.86°
7. Determine which of the following solutions would have the lowest freezing point.
 - a. 15 g of ammonium nitrate in 100. g of water.
 - b. 50. g of glucose in 100. g of water.
 - c. 35 g of calcium chloride in 150. g of water.
8. A 135.0 g sample of an unknown nonelectrolyte compound is dissolved in 725 g of water. The boiling point of the resulting solution was found to be 106.02°C . What is the molecular weight of the unknown compound?
9. What is the van't Hoff factor for each of the following:
 - a. $MgCl_2$
 - b. Ammonium sulfate
 - c. CH_3OH
 - d. Potassium chloride
 - e. KCH_3COO
10. Calcium chloride is known to melt ice faster than sodium chloride but is not used on roads because the salt itself attracts water. If 15 g of $CaCl_2$ was added to 250 g of water, what would be the effect on the freezing point of the solution? ($K_f(\text{water}) = -1.86^\circ\text{C}/m$)

17.7 Separating Mixtures

Lesson Objectives

- list and describe methods of separating mixtures.
- explain the principles involved in chromatographic separation.
- identify the mobile and stationary phases in a chromatography set up.
- calculate R_f values from appropriate data.

Vocabulary

- chromatography
- column chromatography
- distillation
- fractional distillation
- gas chromatography
- paper chromatography
- retention factor
- thin-layer chromatography

Introduction

Mixtures occur very commonly in chemistry. When a new substance is synthesized, for example, the new substance usually must be separated from various side-products, catalysts, and any excess reagent still present. When a substance must be isolated from a natural biological source, the substance of interest is generally found in a very complex mixture with many other substances, all of which must be removed. Chemists have developed a series of standard methods for the separation of mixtures. In fact, the separation of mixtures into their constituent substances defines an entire sub-field of chemistry referred to as separation science.

Differing Solubilities

Mixtures of solids may often be separated on the basis of differences in their solubilities. If one component of the mixture is soluble in water while the other components are insoluble in water, the water-soluble component can be removed from the mixture by dissolving the mixture in water and filtering the mixture through filter paper. The component dissolved in water will pass through the filter while the undissolved solids will be caught in the filter. Since the solubility of substances is greatly influenced by temperature, it may also be possible to separate the components by controlling the temperature at which the solution occurs or at which the filtration is performed. Often times, a sample is added to water and heated to boiling. The hot sample is then filtered to remove completely insoluble substances. The sample is then cooled to room temperature or below, which causes crystallization of

those substances whose solubilities are very temperature dependent. These crystals can then be separated by another filtration, and the filtrate (the material that went through the filter) will then contain only those substances whose solubilities are not as temperature dependent.

Distillation

Homogeneous solutions are most commonly separated by distillation. In general, **distillation** involves heating a liquid to its boiling point, then collecting, cooling, and condensing the vapor produced into a separate container. A common distillation setup is illustrated below.

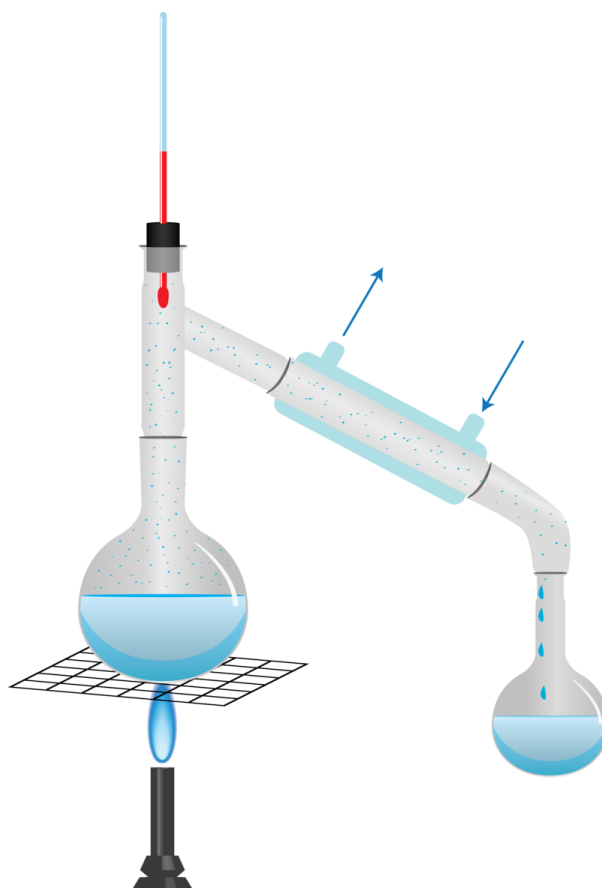

In solutions of non-volatile (resistant to vaporization) solid solutes in liquid solvent, when the solution is boiled, only the solvent boils off and all of the solid remains in the solution. As the solvent vaporizes and all of the solute remains behind, the same amount of solute is now dissolved in less solvent. Since the concentration increases, the boiling point of the solution is also increasing. As the solution boils, increased temperature is necessary to keep the solution boiling because its boiling point has increased. This is a quick method of determining if a liquid is a pure substance or a solution: start boiling the solution, and if it continues to boil at the same temperature, it is a pure substance, whereas if its boiling point increases, it is a solution.

For a mixture of liquids in which several components of the mixture are likely to be volatile (easily vaporized), the separation is not as easy. If the components of the mixture differ reasonably in their boiling points, it may be possible to separate the mixture simply by monitoring the temperature of the vapor produced as the mixture is heated. Liquid components of a mixture will each boil in turn as the temperature is gradually increased, with a sharp rise in the temperature of the vapor being distilled indicating when a new component of the mixture has begun to boil. By

changing the receiving flask at the correct moment, a separation can be accomplished. This process is known as **fractional distillation**.

Chromatography

Chromatography is another method for separating mixtures. The word chromatography means color-writing. The name was chosen around 1900 when the method was first used to separate colored components from plant leaves. Chromatography in its various forms is perhaps the most important known method for the chemical analysis of mixtures. Paper and thin-layer chromatography are simple techniques that can be used to separate mixtures into the individual components. The methods are very similar in operation and principle. They differ primarily in the medium used.

Paper chromatography uses ordinary filter paper as the medium upon which the mixture to be separated is applied. **Thin-layer chromatography (TLC)** uses a thin coating of aluminum oxide or silica gel on a glass microscope slide or plastic sheet to which the mixture is applied. A single drop of the unknown mixture to be separated is applied about half an inch from the end of a strip of filter paper or TLC slide. The filter paper or TLC slide is then placed in a shallow layer of solvent in a jar or beaker. Since the filter paper and the TLC slide coating are permeable to liquids, the solvent begins rising up the paper by capillary action.

As the solvent rises to the level of the mixture spot, various effects can occur, depending on the constituents of the spot. Those components of the spot that are completely soluble in the solvent will be swept along with the solvent front as it continues to rise. Those components that are not at all soluble will be left behind at the original location of the spot. Most components of the mixture will move up the paper or slide at an intermediate speed somewhat less than the solvent front speed. In this way, the original mixture spot is spread out into a series of spots or bands, with each spot representing one single component of the mixture, as seen in the illustration of a paper chromatography strip below.

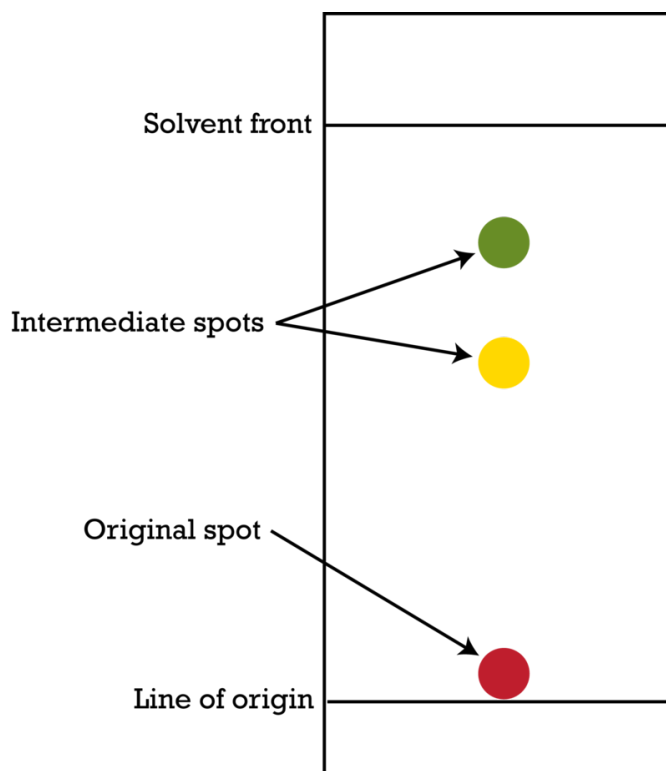

The separation of a mixture by chromatography is not only a function of the solubility in the solvent used. The filter

paper or TLC coating consists of molecules that may interact with the molecules of mixture as they are carried up the medium. The primary interaction between the mixture components and the medium is due to the polarity of the components and that of the medium. Each component of the mixture is likely to interact with the medium to a different extent, thus slowing the components of the mixture differentially depending on the level of interaction.

In chromatography analysis, there is a mathematical function called the retention factor. The **retention factor**, R_f , is defined as

$$R_f = \frac{\text{distance traveled by spot}}{\text{distance traveled by solvent front}}$$

R_f is the ratio of the distance a substance moves up the stationary phase to the distance the solvent have moved. The retention factor depends on what solvent is used and on the specific composition of the filter paper or slide coating used. The R_f value is characteristic of a substance when the same solvent and the same type of stationary phase is used. Therefore, a set of known substances can be analyzed at the same time under the same conditions.

In the case shown below, the R_f for the green spot is

$$R_f = \frac{2.7\text{cm}}{5.7\text{ cm}} = 0.47$$

and for the yellow spot

$$R_f = \frac{1.8\text{ cm}}{5.7\text{ cm}} = 0.32$$

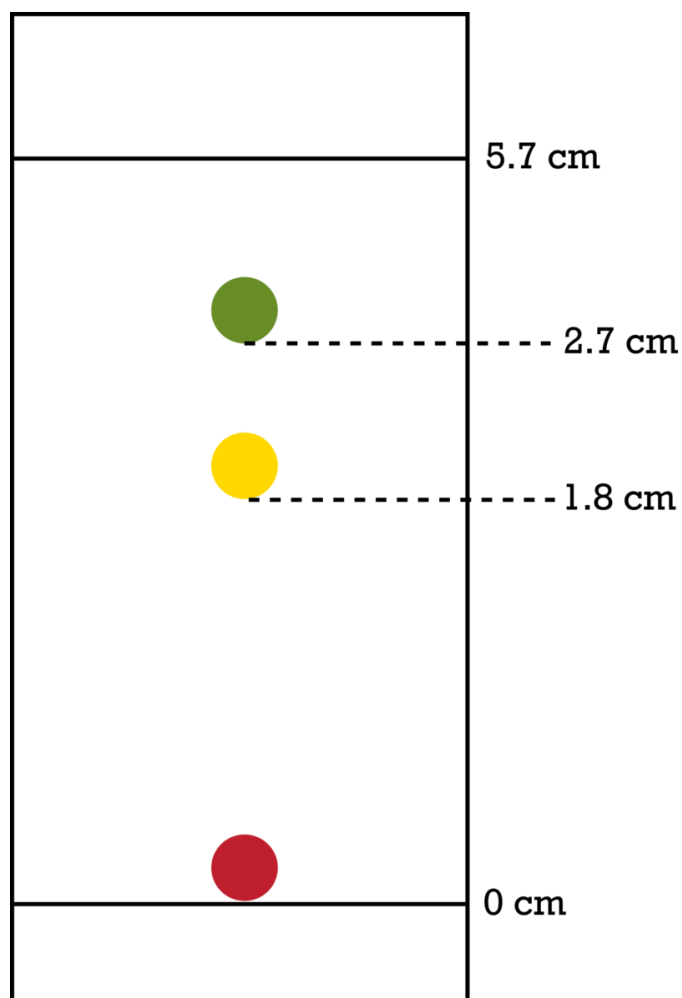

Paper chromatography and TLC are only two examples of many different chromatographic methods. Mixtures of gases are commonly separated by **gas chromatography**. In this method, a mixture of liquids are vaporized and passed through a long tube of solid absorbent material. A carrier gas, usually helium, is used to carry the mixture of gases through the tube. As with paper chromatography, the components of the mixture will have different solubilities and different attractions for the solid absorbent. Separation of the components occurs as the mixture moves through the tube. The individual components exit the tube one by one and can be collected.

Another form of chromatography is **column chromatography**. In this form, a vertical column is filled with solid absorbent, the mixture is poured in at the top, and a carrier solvent is added. As the mixture flows down the column, the components are separated, again, by differing solubilities in the carrier solvent and different absorbencies to the solid packing. As the liquid drips out the bottom of the column, components of the solution will exit at different times and can be collected.

This video presents thin layer chromatography with fluorescent materials, and column chromatography with UV active materials. There is no narration on the video so it would be advantageous to watch with a chemistry teacher (6f): <http://www.youtube.com/watch?v=gzp2S0e9o8s> (4:27).

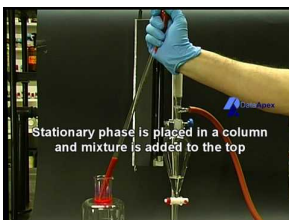

MEDIA

Click image to the left for more content.

Lesson Summary

- Mixtures of solids may be separated by differing solubilities of the solids.
- Components of a solution composed of a non-volatile solid solute and a liquid solvent can be separated by distillation.
- Mixtures of liquids with reasonably different boiling points can also be separated by distillation.
- Solutions with several components can be separated by paper or thin-layer chromatography.
- Gas chromatography and column chromatography are also used to separate the components of a solution.

This video describes methods used to separate the components of a mixture (1a IE): http://www.youtube.com/watch?v=jWdu_RVy5_A (2:30).



MEDIA

Click image to the left for more content.

Further Reading / Supplemental Links

An interactive video on separating mixtures is available at the link below.

- http://www.bbc.co.uk/schools/ks3bitesize/science/chemical_material_behaviour/compounds_mixtures/activity.shtml

Review Questions

1. In a paper chromatography experiment to separate the various pigments in chlorophyll, a mixture of water and ethanol was used as the solvent. What is the stationary phase in this separation?
2. Do you think that paper chromatography or TLC would be useful for separating a very large quantity of a mixture? Explain why or why not.
3. If the mobile phase in a chromatographic experiment moved 15.0 cm and one of the compounds in the mixture moved 12.7 cm, what is the R_f value for this compound?
4. If the stationary phase in a paper chromatography experiment was very polar and the solvent was moderately polar, would the polar components in the mixture be closer to the bottom of the paper or toward the top of the paper?

17.8 Reactions Between Ions in Solutions

Lesson Objectives

The student will:

- use a solubility chart or solubility rules to determine whether or not a given substance is soluble in water.
- use a solubility chart or solubility rules to determine if a precipitate is likely when specified solutions are combined.
- write molecular, ionic, and net ionic equations.
- identify spectator ions in ionic equations.
- explain what is meant by a precipitation reaction and give an example of one.
- identify the spectator ions in any precipitation reaction.
- write the balanced complete ionic equation and the net ionic equation for any precipitation reaction.

Vocabulary

- gravimetric analysis
- ionic equation
- net ionic equation
- precipitate
- precipitation reaction
- spectator ions

Introduction

Many ionic compounds are said to be soluble in water, while others are said to be insoluble. However, no ionic compound is completely insoluble in water. Every ionic compound dissociates into its ions to some extent when placed in water. In fact, the solubility of ionic compounds ranges across a full spectrum from as little solubility as 1×10^{-100} moles/liter to 20 moles/liter. When solutes are dissolved in a solution, the solution is transparent so the dissolved solute particles cannot be visually detected. If undissolved particles are present in a liquid, they form a cloudy barrier to light passing through the liquid and hence their presence can be detected visually. Eventually, the un-dissolved particles will settle to the bottom of the container, making it more apparent that an un-dissolved solid is present.

When ionic solutions are mixed together, it is often possible to form an insoluble ionic compound even though both original compounds were soluble. For example, both silver nitrate and sodium chloride are soluble compounds. In 1.0 M solutions of these substances, the compounds would completely dissociate. One solution would contain Ag^+ and NO_3^- ions, and the other solution would contain Na^+ and Cl^- ions. When these two solutions are poured together, all of these ions move around in the solution and come into contact with each other. When a silver ion combines with a chloride ion, they form an insoluble solid particle that will not dissolve. Therefore, when the

two solutions are mixed, a cloudy, non-transparent substance forms that will eventually settle to the bottom of the container, as illustrated below. When a non-soluble substance is formed in a solution, it is called a **precipitate**. A **precipitation reaction** is a reaction in which soluble ions in separate solutions are mixed together to form an insoluble compound that settles out of the solution.

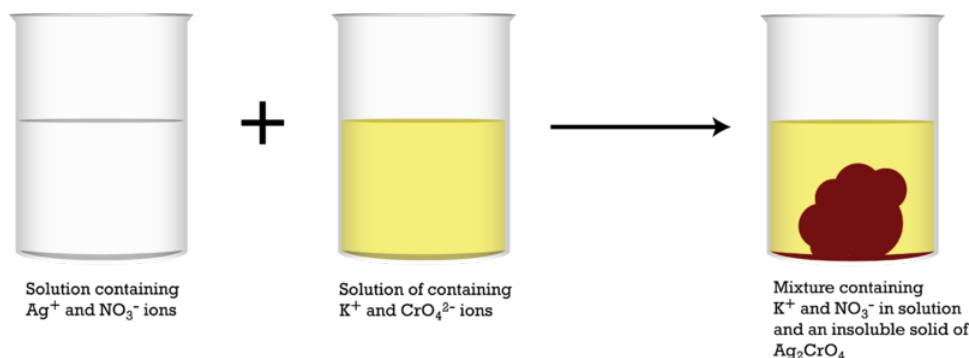

Product Precipitates

Once a solid substance has been separated into its ions, the ions are then available for reactions. When a compound is in the solid state, the ions are held with electrostatic attractions. It must first be dissolved in solution before the ions can move freely. Take for example the reaction between sodium chloride and silver nitrate. Both of these compounds are available commonly in the solid form. First, both solids are dissolved in water, as seen below:

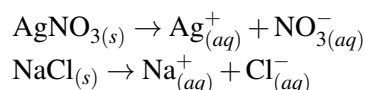

Once the solid dissolves to separate into its ions in solution, these ions are available to react together in the following chemical reaction:

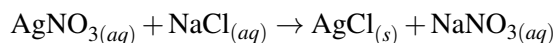

Make note that the $\text{AgNO}_{3(aq)}$ and $\text{NaCl}_{(aq)}$ reactants show the ions are in solution. In other words, $\text{AgNO}_{3(aq)}$ is equivalent to $\text{Ag}_{(aq)}^{+} + \text{NO}_{3(aq)}^{-}$, and $\text{NaCl}_{(aq)}$ is equivalent to $\text{Na}_{(aq)}^{+} + \text{Cl}_{(aq)}^{-}$. The equation represented above is a double displacement reaction, which means the cations exchange anions in the reactants to form the products. The precipitate that will form in this case is silver chloride.

The same reactions can be seen when substances undergo ionization. Remember that ionization forms ions in solution. For example, look at the equations below for the ionization of sulfuric acid and the dissolution of sodium hydroxide. Notice how they both end up with ions in solution.

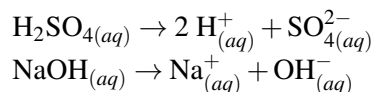

When sulfuric acid reacts with sodium hydroxide, we have a double displacement reaction where the cations exchange anions, as seen below:

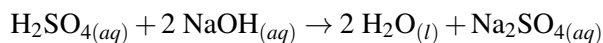

Notice that liquid water is produced, not a solid. The second product is an aqueous ionic solution containing the ions $\text{Na}_{(aq)}^{+}$ and $\text{SO}_{4(aq)}^{2-}$ (illustrated below).

When the text says this:

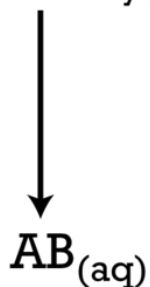

Think this:



Solubility Charts and Solubility Rules

How do you know if a precipitate is produced in a double replacement reaction? Not all reactions of this type will produce a precipitate. If you were to mix a solution of table salt ($\text{NaCl}_{(aq)}$) and Epsom salts ($\text{MgSO}_{4(aq)}$) in water, you would not get a precipitate. The reaction is seen below:

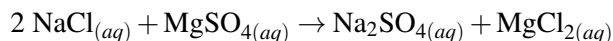

Scientists use a set of solubility rules or a solubility chart to determine whether or not a precipitate will form. **Table 17.7** represents the solubility chart for the most common cations and anions found in ionic solids.

TABLE 17.7: Solubility Chart

	$\text{C}_2\text{H}_3\text{O}_2\text{Br}^-$	CO_3^{2-}	Cl^-	ClO_3^-	CrO_4^{2-}	I^-	NO_3^-	OH^-	O^{2-}	PO_4^{3-}	SO_4^{2-}	S^{2-}
Ag^+	ii	I	I	S	ii	I	S	*	ii	I	ii	I
Al^{3+}	S	S	*	S	S	*	S	I	I	I	S	*
Ba^{2+}	S	S	ii	S	S	I	S	S	S	I	I	*
Ca^{2+}	S	S	ii	S	S	ii	S	ii	ii	ii	ii	ii
Cu^{2+}	S	S	*	S	S	*	*	S	I	I	I	S
Fe^{2+}	S	S	ii	S	S	*	S	S	I	I	I	S
Fe^{3+}	S	S	*	S	S	I	S	S	I	I	ii	ii
Hg_2^{2+}	S	S	*	S	S	ii	ii	S	I	ii	I	I
K^+	S	S	S	S	S	S	S	S	S	S	S	S
Mg^{2+}	S	S	ii	S	S	ii	S	S	I	I	ii	S
Mn^{2+}	S	S	ii	S	S	*	S	S	I	I	ii	S
Na^+	S	S	S	S	S	S	S	S	S	S	S	S
NH_4^+	S	S	S	S	S	S	S	S	S	S	S	S
Pb^{2+}	S	I	I	I	S	I	I	S	ii	ii	I	ii
Sn^{2+}	*	S	*	S	S	I	S	S	I	I	I	S
Sn^{4+}	S	S	*	*	S	ii	*	S	ii	I	*	S
Sr^{2+}	S	S	ii	S	S	ii	S	S	S	S	I	ii
Zn^{2+}	S	S	ii	S	S	ii	S	S	I	ii	I	S

S = soluble in water, I = insoluble in water, ii = partially soluble in water, * = unknown or does not exist.

Let's now see how we use the solubility chart to determine if two compounds will form a precipitate when they react. If we had a reaction between sodium bromide and silver nitrate, we know that this is a reaction between two compounds and therefore is a double replacement reaction. How do we know the states of the products formed? The reaction is seen below.

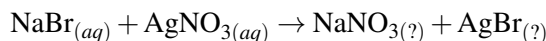

Look at the solubility chart and see if you can predict if the reaction will produce any precipitates. If you look across the row for sodium ion, all sodium compounds are soluble (S), therefore you can fill in this part of the equation:

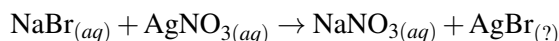

If you look across the row for silver, under bromide ion, you find an I for insoluble.

Therefore we can complete the equation:

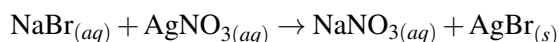

Let's try another one. Take the reaction between ammonium phosphate and lead acetate.

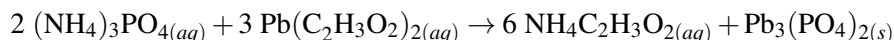

How did we know that the lead(II) phosphate would precipitate from solution? Why did the ammonium acetate not precipitate? If we follow the ammonium row in the solubility table across to the acetate column, we find an "S" at the intersection. This indicates that this compound is soluble. If we follow the lead row across to the phosphate column, we find an "I" at the intersection. This indicates that this compound is insoluble and therefore a precipitate of this compound will form.

Rather than using a solubility chart, some scientists simply use a set of solubility rules. Solubility rules are summaries of information about which ionic compounds are soluble in aqueous solutions and which are not. The rules are as follows:

1. All group 1 metals and ammonium compounds are soluble.
2. All nitrates, chlorates, and bicarbonates are soluble.
3. Halides are soluble except for Ag^+ , Hg_2^{2+} , and Pb^{2+} .
4. Sulfates are soluble except for Ag^+ , Ba^{2+} , Ca^{2+} , Hg_2^{2+} , Sr^{2+} , and Pb^{2+} .
5. Carbonates, chromates, phosphates, and sulfides are insoluble except those from rule #1.
6. Hydroxides are insoluble except for those in rule #1 and Ba^{2+} .

It is important to remember that this is a priority set of rules. What this means is that Rule #1 is first. All group 1 metals and ammonium compounds are always soluble. For example, even though sulfide compounds are rarely soluble for any cation (rule #5), they will be soluble with group 1 metal ions or with ammonium ions (rule #1). It also does not matter whether you use the set of rules or the solubility chart. They both provide the same information; the chart is easier to read for some, while the rules are easier to remember for others.

Example:

Complete the following reactions. Use the solubility table to predict whether precipitates will form in each of the reactions.

1. $\text{Pb}(\text{NO}_3)_2(\text{aq}) + \text{KI}(\text{aq}) \rightarrow$
2. $\text{BaCl}_2(\text{aq}) + \text{Na}_2\text{SO}_4(\text{aq}) \rightarrow$

Solution:

1. $\text{Pb}(\text{NO}_3)_2(\text{aq}) + 2 \text{KI}(\text{aq}) \rightarrow \text{PbI}_2(\text{s}) + 2 \text{KNO}_3(\text{aq})$
2. $\text{BaCl}_2(\text{aq}) + \text{Na}_2\text{SO}_4(\text{aq}) \rightarrow \text{BaSO}_4(\text{s}) + 2 \text{NaCl}(\text{aq})$

Suppose that a chemist has a solution that contains both Pb^{2+} and Zn^{2+} ions. If these two ions were dissolved in the solution as nitrates, then the only anion present is the nitrate ion. If the chemist added some NaCl to the solution, the zinc ions would remain in solution because ZnCl_2 is soluble, but the lead ions and the chloride ions would form the precipitate PbCl_2 . If this mixture is poured through a piece of filter paper, the dissolved zinc ions would pass through the filter paper with the solution but the solid PbCl_2 would be filtered out (illustrated below). Therefore, the chemist would have separated the zinc ions (now in the solution) and the lead ions (now in the filter paper). This process for separating and identifying ions by selective precipitation and filtration is known as **gravimetric analysis**.



If you are called upon to determine a process for separating ions from each other, you should look in the solubility table to determine a reagent that will form a precipitate with one of the ions but not with the other.

Ionic Equations

Remember earlier we said that $\text{NaCl}(\text{aq})$ should be visualized as $\text{Na}^+(\text{aq})$ and $\text{Cl}^-(\text{aq})$, and $\text{AgNO}_3(\text{aq})$ as $\text{Ag}^+(\text{aq})$ and $\text{NO}_3^-(\text{aq})$. This is so we can write chemical reactions as molecular or formula equations. The equation below is an example of a formula equation.

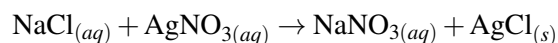

In an **ionic equation**, the separated ions are written in the chemical equation. Let's rewrite the equation above as a total ionic equation, which is a better representation of a double replacement reaction.

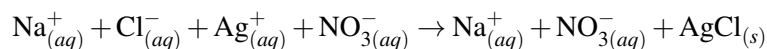
**Example:**

Write the ionic equation for each of the following.

- $\text{BaCl}_{2(aq)} + \text{Na}_2\text{SO}_{4(aq)} \rightarrow 2 \text{NaCl}_{(aq)} + \text{BaSO}_{4(s)}$
- $2 \text{K}_3\text{PO}_{4(aq)} + 3 \text{Ca}(\text{NO}_3)_{2(aq)} \rightarrow 6 \text{KNO}_{3(aq)} + \text{Ca}_3(\text{PO}_4)_{2(s)}$

Solution:

- $\text{Ba}_{(aq)}^{2+} + 2 \text{Cl}_{(aq)}^{-} + 2 \text{Na}_{(aq)}^{+} + \text{SO}_{4(aq)}^{2-} \rightarrow 2 \text{Na}_{(aq)}^{+} + 2 \text{Cl}_{(aq)}^{-} + \text{BaSO}_{4(s)}$
- $6 \text{K}_{(aq)}^{+} + 2 \text{PO}_{4(aq)}^{3-} + 3 \text{Ca}_{(aq)}^{2+} + 6 \text{NO}_{3(aq)}^{-} \rightarrow 6 \text{K}_{(aq)}^{+} + 6 \text{NO}_{3(aq)}^{-} + \text{Ca}_3(\text{PO}_4)_{2(s)}$

Net Ionic Equations

If you look at the equation below, what do you notice is the same on both sides of the equation?

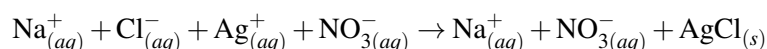

Do you see that $\text{Na}_{(aq)}^{+}$ and $\text{NO}_{3(aq)}^{-}$ appear on both sides of this equation in the same form? These ions, because they appear on both sides of the equation and in the same form, are called spectator ions. A **spectator ion** is an ion in the ionic equation that appears in the same form on both sides of the equation, indicating they do not participate in the overall reaction. Therefore $\text{Na}_{(aq)}^{+}$ and $\text{NO}_{3(aq)}^{-}$ are spectator ions for this reaction. By removing the spectator ions, the overall reaction will become:

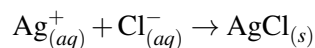

Without the spectator ions, we see only the ions that are responsible for forming the solid silver chloride. This equation, represented above, is the net ionic equation. The **net ionic equation** is the overall equation that results when spectator ions are removed from the ionic equation. The net ionic equation gives us all of the essential information we need: what ions we need to form our solid. In this case, it is irrelevant whether we had sodium chloride or potassium chloride, as what is important is that the chloride ion and silver ion are present.

Example:

Write the net ionic equation for each of the following. Name the spectator ions.

- $\text{Ba}_{(aq)}^{2+} + 2 \text{Cl}_{(aq)}^{-} + 2 \text{Na}_{(aq)}^{+} + \text{SO}_{4(aq)}^{2-} \rightarrow 2 \text{Na}_{(aq)}^{+} + 2 \text{Cl}_{(aq)}^{-} + \text{BaSO}_{4(s)}$
- $6 \text{K}_{(aq)}^{+} + 2 \text{PO}_{4(aq)}^{3-} + 3 \text{Ca}_{(aq)}^{2+} + 6 \text{NO}_{3(aq)}^{-} \rightarrow 6 \text{K}_{(aq)}^{+} + 6 \text{NO}_{3(aq)}^{-} + \text{Ca}_3(\text{PO}_4)_{2(s)}$

Solution:

- $\text{Ba}_{(aq)}^{2+} + 2 \text{Cl}_{(aq)}^{-} + 2 \text{Na}_{(aq)}^{+} + \text{SO}_{4(aq)}^{2-} \rightarrow 2 \text{Na}_{(aq)}^{+} + 2 \text{Cl}_{(aq)}^{-} + \text{BaSO}_{4(s)}$

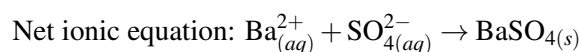

Spectator ions: $\text{Cl}^-_{(aq)}$ and $\text{Na}^+_{(aq)}$

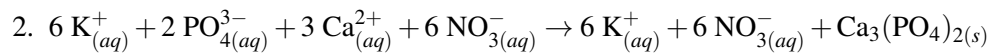

Net ionic equation: $2 \text{PO}^{3-}_{4(aq)} + 3 \text{Ca}^{2+}_{(aq)} \rightarrow \text{Ca}_3(\text{PO}_4)_2(s)$

Spectator ions: $\text{K}^+_{(aq)}$ and $\text{NO}^-_{3(aq)}$

Lesson Summary

- A solubility chart is a grid showing the possible combinations of cations and anions and their solubilities in water. It is used to determine whether a precipitate is formed in a chemical reaction.
- Solubility rules are summaries of information about which ionic compounds are soluble in aqueous solutions and which are not.
- A total ionic equation is one in which all of the ions in a reaction are represented.
- A net ionic equation is one in which only the ions that produce the precipitate are represented.

Further Reading / Supplemental Links

This web site video shows a series of precipitation reactions.

- <http://www.youtube.com/watch?v=RjBjwQF276A>

This video is a ChemStudy film called “Molecular Spectroscopy.” The film is somewhat dated but the information is accurate.

- <http://www.youtube.com/watch?v=mNaipM3WEO0>

Review Questions

1. What is more valuable to use for determining solubility: a solubility chart or a set of solubility rules?
2. If you were told to visualize $\text{Cu}(\text{NO}_3)_2(aq)$, what might this mean to you?

Use the solubility rules to determine the following solubilities in water.

3. Which of the following compounds is soluble in water?
 - a. PbCl_2
 - b. Hg_2Cl_2
 - c. $(\text{NH}_4)_2\text{SO}_4$
 - d. MgCO_3
 - e. AgNO_3
 - f. MgCl_2
 - g. KOH
 - h. PbSO_4

4. When only the ions that produce a precipitate are shown for a chemical equation, what type of reaction exists?
 - a. spectator equation
 - b. molecular equation
 - c. ionic equation
 - d. net ionic equation
5. Complete the following reactions:
 - a. $\text{Na}_2\text{S}_{(aq)} + \text{ZnCl}_{2(aq)} \rightarrow$
 - b. $(\text{NH}_4)_2\text{CO}_{3(aq)} + \text{CaCl}_{2(aq)} \rightarrow$
6. Write the ionic equations for the balanced molecular equations from question 7.
7. Write the net ionic equations for the ionic equations from question 8.
8. Identify the spectator ions for the ionic equations from question 8.

All images, unless otherwise stated, are created by the CK-12 Foundation and are under the Creative Commons license CC-BY-NC-SA.

17.9 References

1. Superdvd (<http://commons.wikimedia.org/wiki/File:CuSO4.5H2O.jpg>); Benjah-bmm27 (http://commons.wikimedia.org/wiki/File:CuSO4.5H2O_sulfate-pentahydrate-sample.jpg); modified by Richard Parsons. . Public domain

CHAPTER **18**

Chemical Kinetics

Chapter Outline

- 18.1 RATE OF REACTIONS
 - 18.2 COLLISION THEORY
 - 18.3 POTENTIAL ENERGY DIAGRAMS
 - 18.4 FACTORS THAT AFFECT REACTION RATES
 - 18.5 MULTI-STEP REACTION
-

18.1 Rate of Reactions

Lesson Objectives

The student will:

- define chemical kinetics and rates of reaction.
- write the rate expression and the units for the rate expression.
- define instantaneous rate.
- calculate instantaneous rate using a tangent line.

Vocabulary

- chemical kinetics
- instantaneous rate
- rate of reaction

Introduction

The focus of this chapter is chemical kinetics. **Chemical kinetics** is the study of chemical reactions rates and the factors that affect the rate of reactions. These factors include concentration, temperature, pressure, surface area, and the effect of a catalyst. For example, when food is placed in the refrigerator, the cold temperature keeps the food from decomposing by slowing the rate of reaction. Chemical kinetics plays an important role both in industry and in our daily lives. To begin, we will introduce some of the basic concepts of chemical kinetics.

Change in Concentration Over Time

The term **rate of reaction** is used to denote the rate at which the products are formed in a time interval or the rate at which the reactants are consumed over a time interval. A reaction rate measures how fast or how slow a reaction is. The rusting of a piece of metal has a slow reaction rate because the iron oxidizes in the air over a relatively long time period. A forest fire has a fast reaction rate because it consumes trees in its path in a very short time interval. Reaction rates can be measured as the change in mass per unit time (grams/second) or the change in molarity per unit time (mol/L · s).

Symbolically, the reaction rate is given the letter r . The reaction rate, then, can be written as follows:

$$r = \frac{\Delta \text{concentration}}{\Delta \text{time}}$$

Remember that the symbol Δ means the “change in.”

Example:

For the reaction $\text{H}_{2(g)} + \text{I}_{2(g)} \rightarrow 2 \text{HI}_{(g)}$, under certain conditions, the $[\text{HI}] = 0.50 \text{ mol/L}$ at 25 s and 0.75 mol/L at 40 s. What is the rate of production of HI? Note: remember that the brackets indicate concentration.

Solution:

$$r = \frac{\Delta[\text{HI}]}{\Delta t} = \frac{(0.75 - 0.50) \text{ mol/L}}{(40 - 25) \text{ s}} = \frac{0.25 \text{ mol/L}}{15 \text{ s}} = 1.7 \times 10^{-2} \text{ mol/L} \cdot \text{s}$$

Therefore, the rate of production of HI is $1.7 \times 10^{-2} \text{ mol/L} \cdot \text{s}$.

A blackboard discussion of reaction rate with an eye to developing the rate law and the equilibrium constant (**8a**) is available at http://www.youtube.com/watch?v=_HA1se_gyvs (7:20).

**MEDIA**

Click image to the left for more content.

Units for Rate of Reaction

Notice in the previous example that the units to measure the reaction rate are in $\text{mol/L} \cdot \text{s}$. Therefore, the units are measuring the concentration/time or the M/time. These units allow for the comparison of rates. In other words, if all reaction rates were to use the same units, we can compare one rate to the other. For example, under a different set of conditions, the HI reaction was found to have a reaction rate of $2.5 \text{ mol/L} \cdot \text{s}$. We could then predict that the new set of conditions are favorable for this reaction since the reaction rate was faster for the production of HI in the same time interval.

Graphing Instantaneous Rate

Instantaneous rate is defined as the rate of change at a particular moment. For example, a police officer stops a car for speeding. The radar gun on a police cruiser is set to measure the speed of a motorist as the motorist comes close to the cruiser. The driver of the vehicle is stopped doing 65 miles/hour in a 50 miles/hour zone. The cruiser measured the rate of speed at that instant in time when the driver passed the police officer. This is instantaneous rate. If we were to take all of the measures of instantaneous rate and graph them, we would obtain a curve of the overall speed (or the average speed) of the vehicle. The same is true for reactions. For reactions, the instantaneous rate is the rate of the reaction at a specific time in the reaction sequence. If you were to graph the rate of the reactant being consumed versus time, the graph would look like the figure below. As the reaction proceeds, the concentration of the reactants decreases over time.

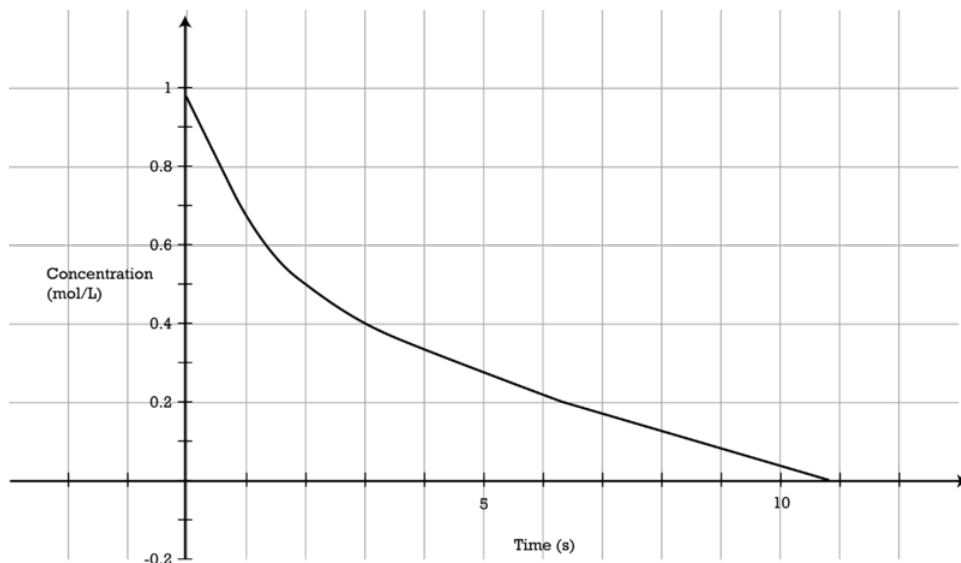

The initial rate of the reaction is found at $t = 0$ s, or when the reaction is just beginning. It is at this point when the maximum amount of the reactant is present. To find the instantaneous rate, a tangent line is drawn to this curve. The slope of this tangent line is then found. For example, say we wanted to know the instantaneous rate at $t = 2$ s. After drawing the tangent line (see figure below), we can calculate the slope of the tangent line to find the instantaneous rate at $t = 2$ s.

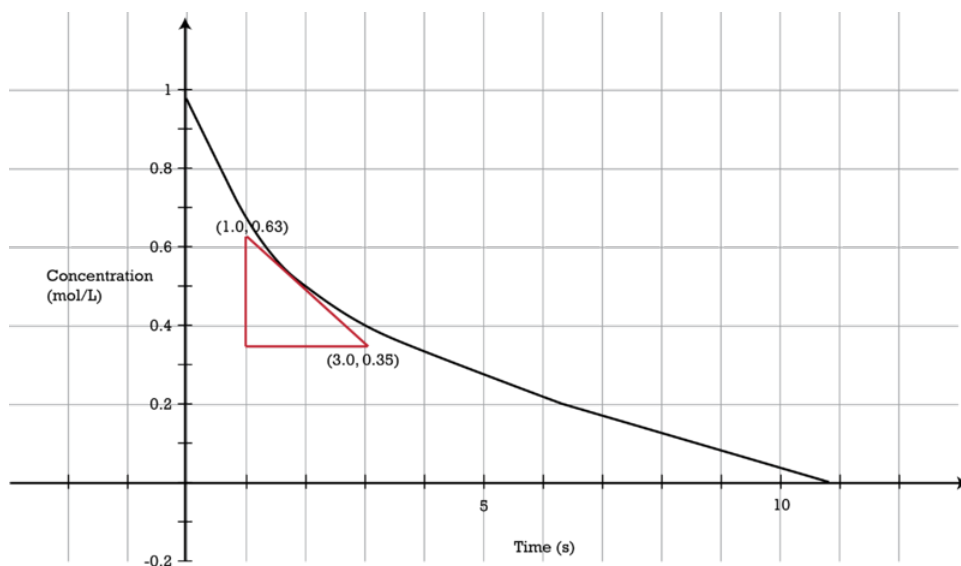

$$\text{rate} = \frac{y_2 - y_1}{x_2 - x_1} = \frac{0.35 - 0.63}{3.0 - 1.0} = \frac{-0.28 \text{ mol/L}}{2.0 \text{ s}} = -0.14 \text{ mol/L} \cdot \text{s}$$

Lesson Summary

- Chemical kinetics is the study of rates of chemical reactions and how factors affect rates of reactions. The term rate of reaction is used to denote the measure at which the products are formed over a time interval or the rate at which the reactants are consumed over a time interval.
- The units to measure the reaction rate are in $\text{mol/L} \cdot \text{s}$.
- Instantaneous rate is defined as the rate of change at a particular moment.

Further Reading / Supplemental Links

The website below provides more details about measuring reaction rates.

- http://chemwiki.ucdavis.edu/Physical_Chemistry/Kinetics/Reaction_Rates/Measuring_Reaction_Rates

Review Questions

- Given that the concentration of $\text{NO}_2(g)$ is 0.40 mol/L at 45 s and 0.85 mol/L at 80 s, what is the rate of production of $\text{NO}_2(g)$ in: $\text{NO}_2(g) + \text{CO}(g) \rightarrow \text{NO}(g) + \text{CO}_2(g)$?
- For the graph below, draw a tangent line at $t = 0.40$ s and calculate the instantaneous rate.

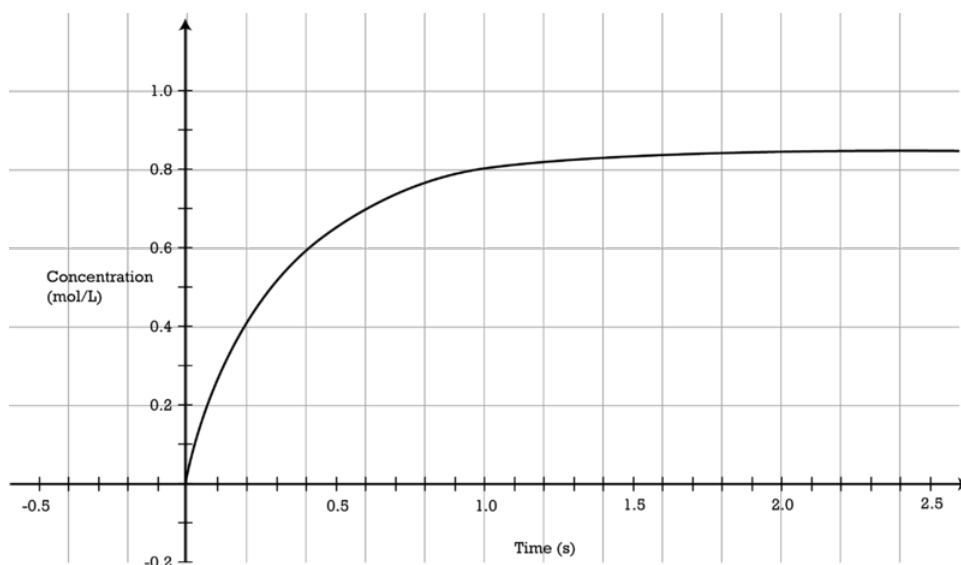

- Which expression represents the rate for the product formation for the reaction: $\text{Mg}(s) + 2 \text{HCl}(aq) \rightarrow \text{MgCl}_2(aq) + \text{H}_2(g)$?
 - rate = $\frac{\Delta[\text{Mg}]}{\Delta t}$
 - rate = $\frac{\Delta[\text{HCl}]}{\Delta t}$
 - rate = $\frac{\Delta[\text{MgCl}_2]}{\Delta t}$
 - All of these are accurate representations of the rate.
- Which statement represents a rate?
 - The speed of a car is 50 km/h.
 - Half the product is produced.
 - A family consumes 5 L of milk.
 - I ran for 45 minutes.
- Which statement about the instantaneous rate of a reaction is correct?
 - The higher the rate, the smaller the slope of a line on a concentration-time graph.
 - The instantaneous rate is the slope of the tangent to a line on a concentration-time graph.
 - The instantaneous rate is the slope of the cosine to a line on a concentration-time graph.
 - All of these statements are correct.
- What is the rate of production of NO gas if the concentration decreases from 0.32 mol/L at 56 s and 0.94 mol/L at 78 s for the reaction $4 \text{NH}_3(g) + 5 \text{O}_2(g) \rightarrow 4 \text{NO}(g) + 6 \text{H}_2\text{O}(g)$?

- a. $-35 \text{ mol/L}\cdot\text{s}$
 - b. $-2.8 \times 10^2 \text{ mol/L}\cdot\text{s}$
 - c. $2.8 \times 10^{-2} \text{ mol/L}\cdot\text{s}$
 - d. $35 \text{ mol/L}\cdot\text{s}$
7. It takes 15 minutes for the concentration of a reactant to decrease from 0.45 mol/L to 0.030 mol/L . What is the rate of reaction in $\text{mol/L}\cdot\text{s}$?

18.2 Collision Theory

Lesson Objectives

The student will:

- define the collision theory.
- describe the conditions for successful collisions.
- explain how the kinetic molecular theory applies to the collision theory.
- describe the rate in terms of the conditions of successful collisions.

Vocabulary

- activated complex
- activation energy
- collision frequency
- collision theory
- kinetic molecular theory
- threshold energy

Introduction

Consider the chemical reaction $\text{CH}_4 + 2 \text{O}_2 \rightarrow \text{CO}_2 + 2 \text{H}_2\text{O}$. In the reactants, the carbon atoms are bonded to hydrogen atoms, and the oxygen atoms are bonded to other oxygen atoms. Each atom in the reactants is bonded to its full capacity and cannot form any more bonds. In the products, the carbon atoms are bonded to oxygen atoms, and the hydrogen atoms are bonded to oxygen atoms. The bonds that are present in the products cannot form unless the bonds in the reactants are first broken, which requires an input of energy.

The energy to break the old bonds comes from the kinetic energy of the reactant particles. The reactant particles are moving around at random with an average kinetic energy related to the temperature. If a reaction is to occur, the kinetic energy of the reactants must be high enough that when the reactant particles collide, the collision is forceful enough to break the old bonds. Once the old bonds are broken, the atoms in the reactants would be available to form new bonds. At that point, the new bonds of the products could be formed. When the new bonds are formed, potential energy is released. The potential energy that is released becomes kinetic energy that is absorbed by the surroundings (primarily the products, the solvent solution if there is one, and the reaction vessel).

Chemists have chosen to give a name to the group of particles that exist for the split second just after the reactant bonds have been broken and just before the product bonds form. This group of un-bonded particles is called the **activated complex**. The *activated* part comes from the fact that these atoms are ready to form bonds, and the *complex* part comes from the fact that the group of particles is a jumble of particles from all the reactant molecules. A successful collision would proceed as follows:

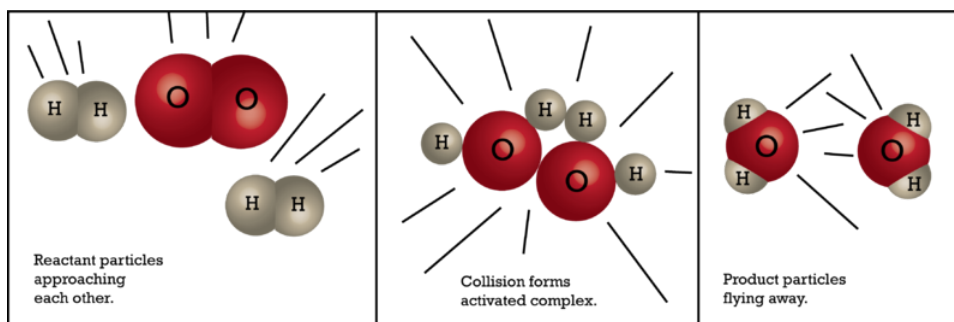

Reactants \rightarrow input of energy \rightarrow activated complex \rightarrow output of energy \rightarrow products

The reactants, the activated complex, and the products all have a precise amount of potential energy in their bonds. The potential energy of the activated complex is called the **threshold energy**. This threshold energy is the minimum potential energy that must be reached in order for a reaction to occur. The input of energy that is necessary to raise the potential energy of the reactants to this threshold energy is called the **activation energy**. The activation energy must be provided from the kinetic energy of the reactant particles during the collision. In those cases where the reactants do not collide with enough energy to break the old bonds, the reactant particles will simply bounce off each other and remain reactant particles.

How Reactions Occur

We know that a chemical system can be made up of atoms (H_2 , N_2 , K), ions (NO_3^- , Cl^- , Na^+), or molecules (H_2O , CH_3CH_3 , $\text{C}_{12}\text{H}_{22}\text{O}_{11}$). We also know that in a chemical system, these particles are moving around at random. The **collision theory** explains why reactions occur between these atoms, ions, and/or molecules at the particle level. The collision theory provides us with the ability to predict what conditions are necessary for a successful reaction to take place. These conditions include:

1. the particles must collide with each other
2. the particles must have proper orientation
3. the particles must collide with sufficient energy to break the old bonds

A chemical reaction involves breaking bonds in the reactants, re-arranging the atoms into new groupings (the products), and the formation of new bonds in the products. Therefore, not only must a collision occur between reactant particles, but the collision has to have sufficient energy to break all the reactant bonds that need to be broken in order to form the products. Some collision geometries need less collision energy than others, and the optimal collision geometry requires the smallest amount of particle kinetic energy for the reaction to occur. If the reactant particles collide with less than the activation energy, the particles will rebound (bounce off each other), and no reaction will occur.

The Kinetic Molecular Theory

The **kinetic molecular theory** provides the foundation for the collision theory. Part of the kinetic molecular theory maintains that the collision between particles are “perfectly elastic.” The term “perfectly elastic” is a term from physics meaning that kinetic energy is conserved in the collision. That is, if no bonds are broken, the colliding

particles simply rebound, and the total kinetic energy before and after the collision is exactly the same. The kinetic molecular theory states that gas molecules consist of particles that are moving in random motion. This random motion is always in a straight line, and the particles only deviate when there is a collision with the walls of a container or with another particle. The only collisions of any consequence, however, are those between other particles.

In the chapter on kinetic-molecular theory, it was discussed that the particles in a sample of material are not all at exactly the same temperature. The particles of the substance actually have a distribution of kinetic energies, and the temperature of the substance is an expression of the average kinetic energy. As a result, some of the particles have more than the average kinetic energy and some have less. Therefore, some of the reactant particles will have sufficient kinetic energy to react, and some of the reactant particles will not.

In a slow reaction, the majority of molecules do not have the minimum amount of energy necessary for a reaction to take place. In the figure below, the graph illustrates the number of molecules in the system versus the kinetic energy of these molecules. The area under the curve represents the total number of particles. The area shaded in red shows the number of molecules that do have sufficient energy for a successful collision.

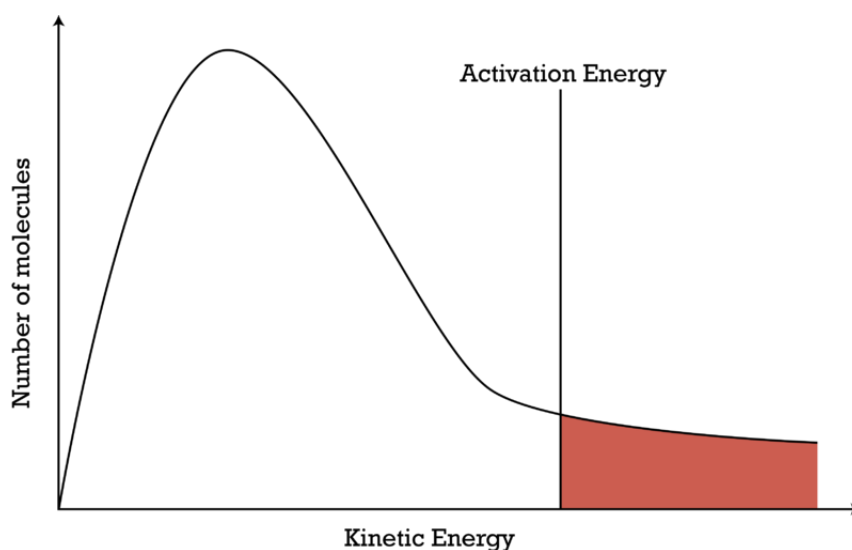

If the temperature is increased, the average kinetic energy of the particles increases, and the number of molecules with sufficient kinetic energy for a successful collision will also increase. The figure below shows the changes due to the increased temperature.

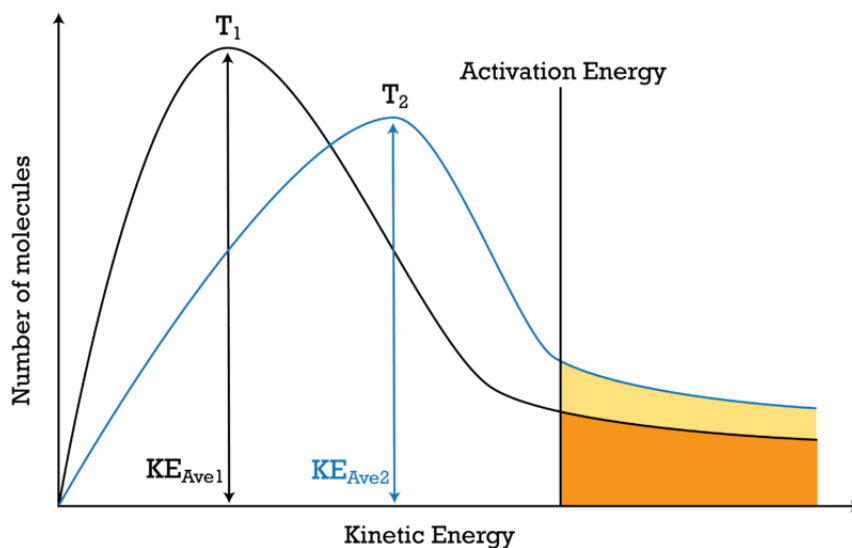

At the higher temperature (T_2), the number of molecules with energy greater than the activation energy increases. Therefore, the number of molecules with enough kinetic energy to have successful collisions increases with increasing average kinetic energy.

Reactions May Occur When Particles Collide

Looking back at the three conditions introduced in the first section, consider the following reaction:

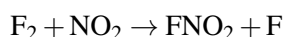

If there is not enough energy, the particles will simply rebound off each other and bonds will not be broken, as illustrated below. The original reactants will remain.

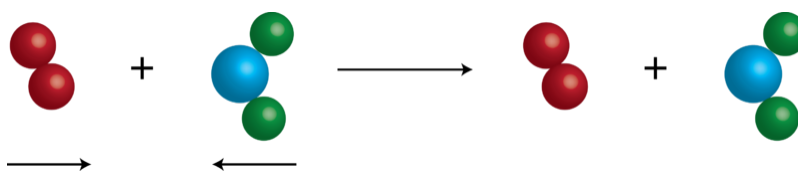

In order to have a successful collision, the particles must collide with enough energy and with the correct geometry to break the F_2 and NO_2 bonds and form the FNO_2 and F products, as seen below. The F would then further react with another element as it is not normally found un-reacted as just F .

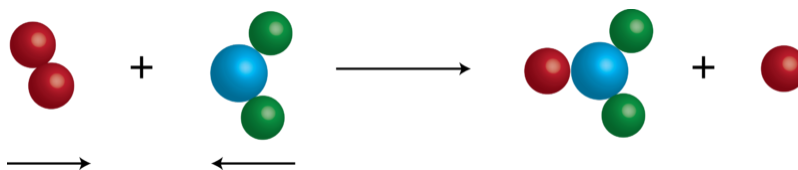

Rate of Reaction Dependent On Various Factors

As stated earlier, there are three conditions that must occur in order for a successful collision to occur. First, the reactant particles must collide. The total number of collisions per second is known as the **collision frequency**, regardless of whether these collisions are successful or not. The collision frequency depends on the concentration of the particles in the container, the temperature of the reaction, and the size of the particles themselves. Second, the particles must collide with the proper orientation. Third, the particles must collide with sufficient energy. From this knowledge, we can conclude that the rate of the reaction depends on the fraction of molecules that have enough energy and that collide with the proper orientation. The rate depends on the collision frequency itself. Putting this all together we get the following:

$$\text{Rate} = \text{collision frequency} \times \text{collision energy} \times \text{collision geometric orientation}$$

Lesson Summary

- The collision theory explains why reactions occur between atoms, ions, and/or molecules and allows us to predict what conditions are necessary for a successful reaction to take place.

- The kinetic molecular theory provides the foundation for the collision theory on the molecular level.
- The minimum amount of energy necessary for a reaction to take place is known as the threshold energy.
- With increasing temperature, the kinetic energy of the particles and the number of particles with energy greater than the activation energy increases.
- The total number of collisions per second is known as the collision frequency, regardless of whether these collisions are successful or not.
- Reaction rate = collision frequency \times collision energy \times collision geometric orientation.

Review Questions

1. According to the collision theory, it is not enough for particles to collide in order to have a successful reaction to produce products. Explain
2. Due to the number of requirements for a successful collision, according to the collision theory, the percentage of successful collisions is extremely small. Yet, chemical reactions are still observed at room temperature and some at very reasonable rates. Explain.
3. What is a basic assumption of the kinetic molecular theory?
 - a. All particles will lose energy as the velocity increases
 - b. All particles will lose energy as the temperature increases
 - c. All particles will increase velocity as the temperature decreases
 - d. All particles are in random motion
4. According to the collision theory, which of the following must happen in order for a reaction to be successful:
 - i. particles must collide, ii. particles must have proper geometric orientation, iii. particles must have collisions with enough energy?
 - a. i, ii
 - b. i, iii
 - c. ii, iii
 - d. i, ii, iii
5. What would happen in a collision between two particles if there was insufficient kinetic energy and improper geometric orientation?
 - a. The particles would rebound and there would be no reaction.
 - b. The particles would keep bouncing off each other until they eventually react, therefore the rate would be slow.
 - c. The particles would still collide but the byproducts would form.
 - d. The temperature of the reaction vessel would increase.
6. Illustrate the successful collision that would occur between the following: $2 \text{NO} + 2 \text{H}_2 \rightarrow \text{N}_2 + 2 \text{H}_2\text{O}$.

18.3 Potential Energy Diagrams

Lesson Objectives

The student will:

- define internal energy.
- describe and draw the difference between endothermic and exothermic potential energy diagrams.
- draw and label the parts of a potential energy diagram.

Vocabulary

- endothermic reaction
- exothermic reaction
- internal energy
- potential energy diagram

Introduction

In this lesson, we go beyond the theoretical perspectives of the collision theory to consider how particle collisions can be represented in energy diagrams. Potential energy diagrams are used in the study of kinetics to show how the potential energy changes during collisions of reactants and products. The features of such diagrams will be the focus of this lesson.

Internal Energy of Reactants and Products, ΔH

Potential energy diagrams illustrate the potential energy of the reactants and products for a chemical reaction and how this energy changes during a reaction. Take a look at the potential energy diagram of the reaction shown below.

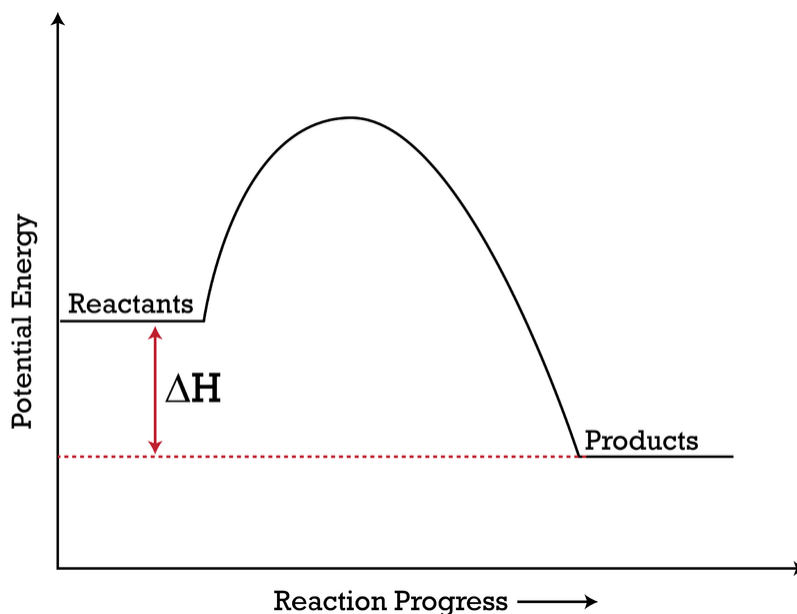

The y-axis represents the potential energy. The potential energy measures the energy stored within the bonds and phases of the reactants and products. This potential energy is a part of the internal energy. In chemical reactions, the **internal energy** represents the total energy of the system and is often called enthalpy. The x-axis represents the reaction progress. Chemical reactions proceed (or are read) from left to right. Therefore, looking at the potential energy diagram, the reactants are usually found to the left on the diagram and the products on the right.

The enthalpy of a substance is sometimes called heat content. The potential energy stored in the bonds of the substance was thought of as heat stored as potential energy. When a reaction occurs, the enthalpy or heat content of the reactants changes into the enthalpy or heat content of the products. The enthalpy of the reactants and products is almost never the same. Therefore, when a reaction occurs, there is a change in the amount of potential energy stored in the bonds between the reactants and the products. If the bonds of the products store more energy than the bonds of the reactants, then energy must be taken in during the reaction. If the bonds of the products store less potential energy than the bonds of the reactants, then excess potential energy will be left over and will come out of the reaction as kinetic energy. The difference in the enthalpy or heat content of the reactants and that of the products is expressed as ΔH , or *the change in enthalpy*. Since this energy is either taken in or given off during the reaction, it is also called *the heat of reaction*.

Exothermic and Endothermic Potential Energy Diagrams

There are two types of potential energy diagrams. These two types center on the difference between the energies of the reactants and products. Consider the figure below. An endothermic reaction is shown on the left, and an exothermic reaction is shown on the right.

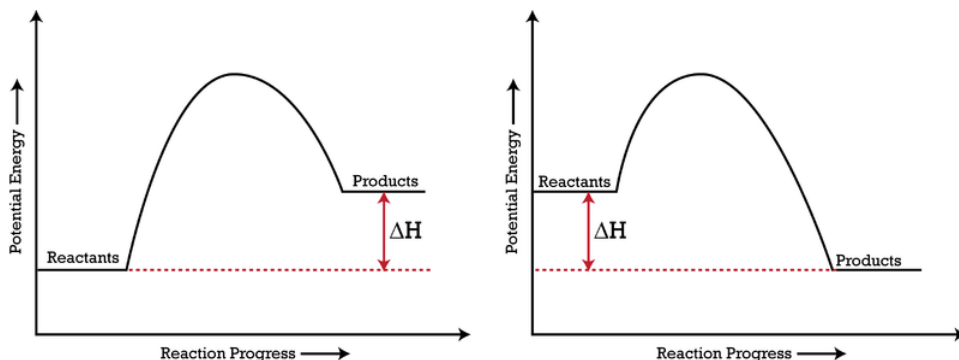

The definition of ΔH is the heat content (enthalpy) of the products minus the heat content (enthalpy) of the reactants, $\Delta H = H_{\text{products}} - H_{\text{reactants}}$. When the enthalpy of the reactants is greater than the enthalpy of the products, heat will be given off by the reaction, so the ΔH will be negative. The opposite is true when the enthalpy of the products is greater than the enthalpy of the reactants.

If the difference between the potential energy of the products and the reactants is positive, or $\Delta H > 0$, the reaction is considered to be **endothermic** (kinetic energy is absorbed and becomes potential energy in the bonds) and is represented by the left figure above. If the difference between the potential energy of the products and the reactants is negative, or $\Delta H < 0$, the reaction is considered to be **exothermic** (excess potential energy from the bonds is left over and comes out into the surroundings as kinetic energy) and is represented by the right figure above.

Activation Energy Barrier

Recall that the activation energy represents the minimum amount of energy required to overcome the energy barrier. This energy must be supplied from the collision energy of the reactant molecules. If the molecules do not have sufficient collision energy to provide the activation energy, then the reaction must be heated to increase the kinetic energy of the reactants in order for the reaction to occur. For instance, hydrogen gas and oxygen gas can be kept in the same container at room temperature for long periods of time without reacting. Even though the molecules are colliding, they do not react since there is insufficient activation energy.

In potential energy diagrams, the symbol for activation energy is often designated as E_a . Look at the two exothermic reactions whose potential energy diagrams are represented in figures A and B below, and notice the activation energy marked in each.

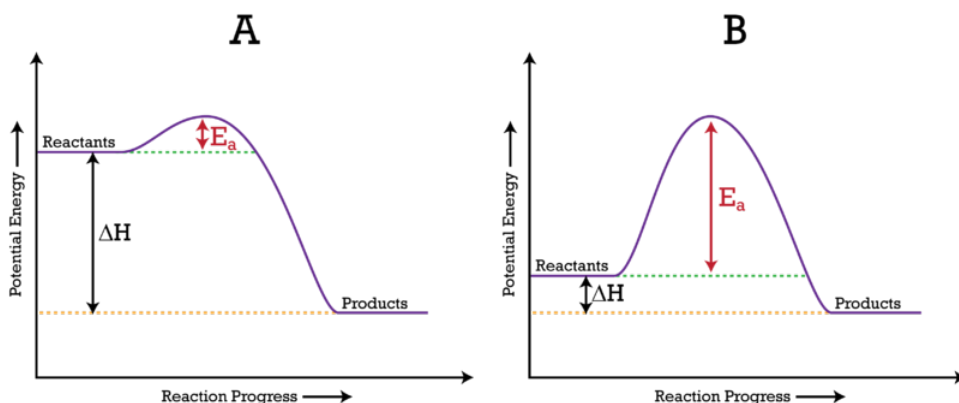

When a reaction has a low activation energy, like in figure A above, most of the reactant molecules have sufficient kinetic energy to react, and the reaction will most likely be rapid (a high reaction rate). When a reaction has a high activation energy, like in figure B above, most of the reactant molecules will *not* have enough energy to react, and the reaction will most likely be very slow.

Activated Complex

Remember that the activated complex is a transitional state between the reactants and products. The transitional complex is a short-lived, very unstable species that is the intermediate between the reactants and products. The activated complex contains the highest amount of energy of all of the species in the reaction. Its position is therefore at the top of the activation energy barrier, as is illustrated below.

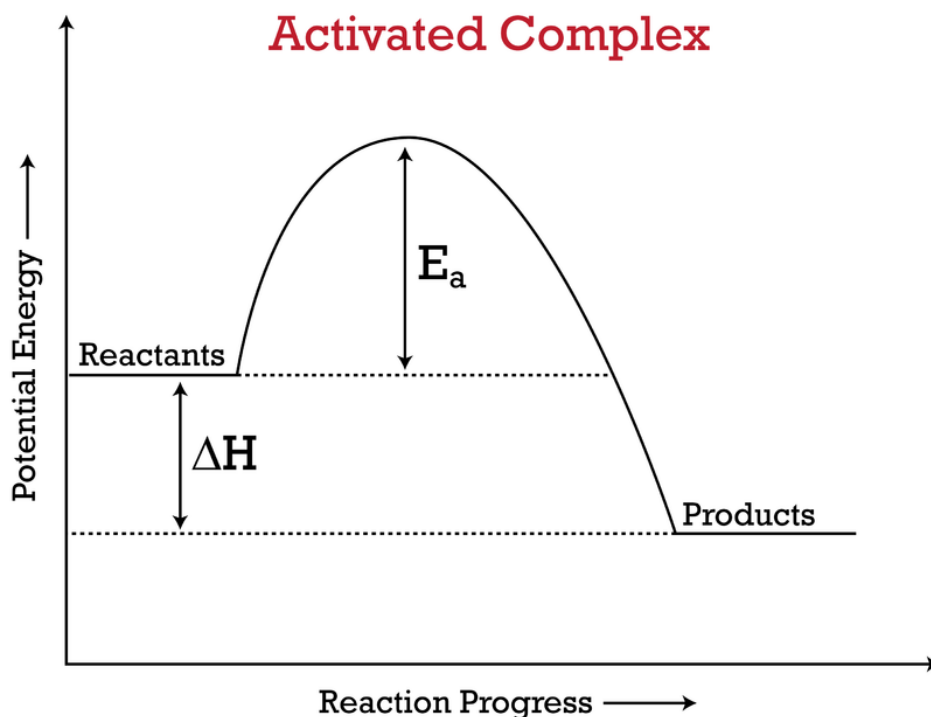

Example:

Consider the reaction between H_2 and I_2 .

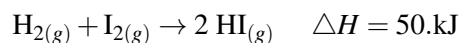

Under certain circumstances, the enthalpy of the reactants is 20 kJ/mol, the activation energy is 80 kJ, and the enthalpy of reaction is 30 kJ. Draw a potential energy diagram with the following properly labeled:

1. the axes
2. the activation energy
3. the change in enthalpy
4. the activated complex

Solution:

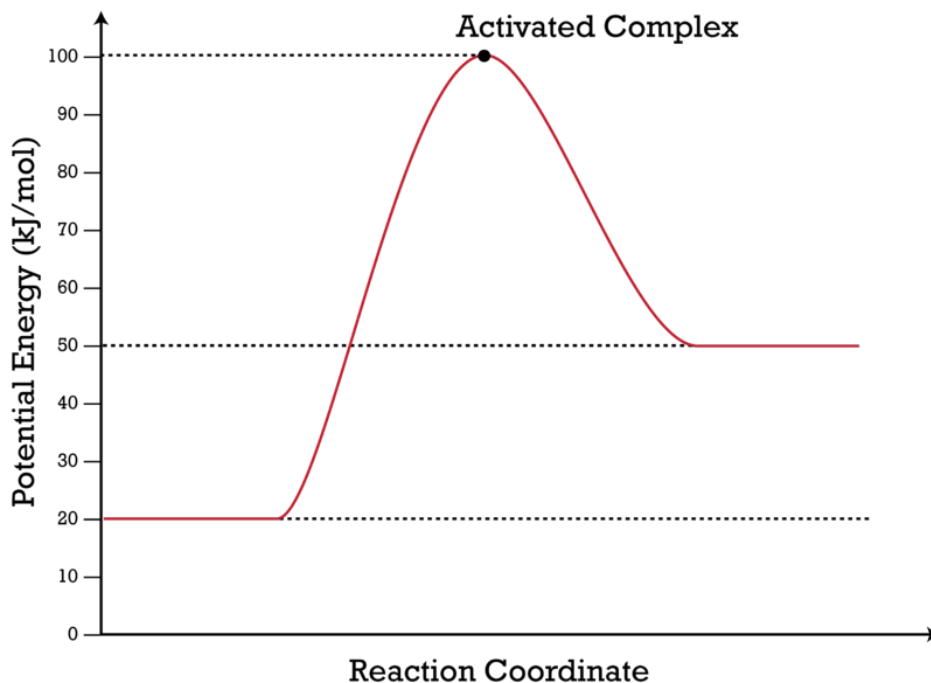
**Example:**

From the potential energy diagram above, list the values for

1. the enthalpy of the reactants
2. the enthalpy of the products
3. the threshold energy
4. the activation energy
5. the change in enthalpy

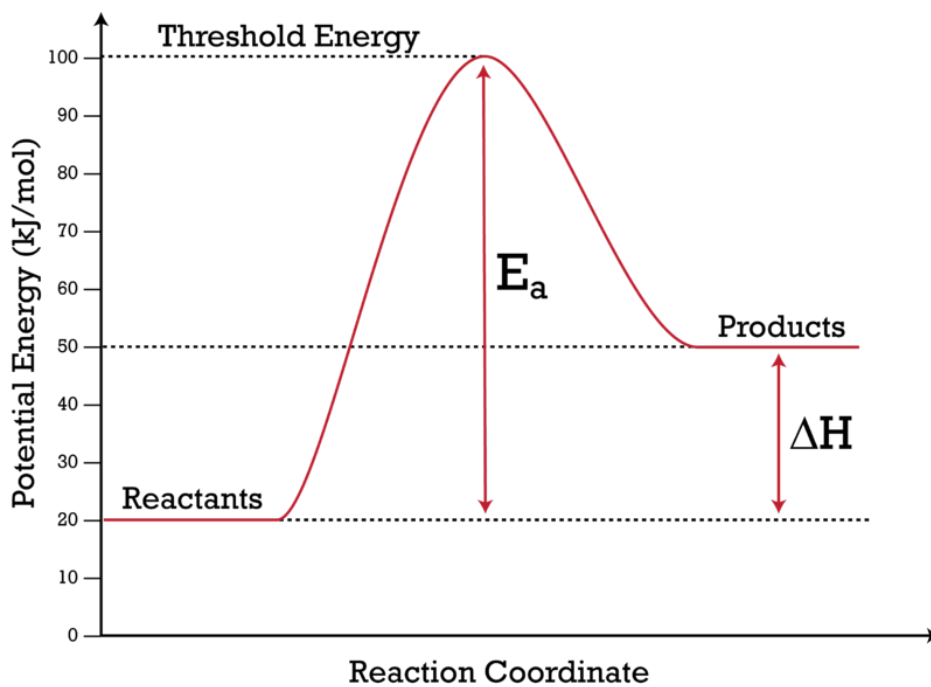
Solution:

1. 20 kJ/mol
2. 50 kJ/mol
3. 100 kJ/mol
4. 80 kJ/mol
5. 30 kJ/mol

Lesson Summary

- Potential energy diagrams show how the potential energy changes during reactions from reactants and products.
- Exothermic reactions have a potential energy difference between the products and reactants that is negative.
- Endothermic reactions have a potential energy difference between the products and reactants that is positive.
- In potential energy diagrams, the symbol for activation energy is often designated as E_a .
- The activated complex is positioned at the top of the activation energy barrier.

Further Reading / Supplemental Links

Visit the website below for an animation on exothermic and endothermic reactions.

- <http://www.mhhe.com/physsci/chemistry/essentialchemistry/flash/activa2.swf>

Review Questions

1. Define and explain the importance of the activation energy.

Use the diagram below to answer questions 2 through 6.

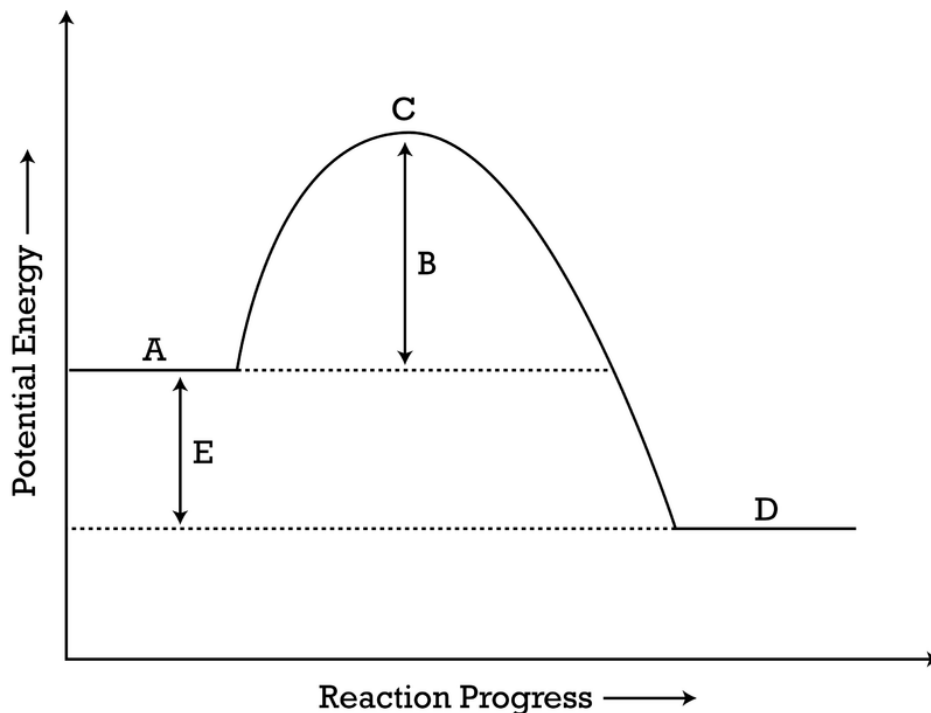

2. Which letter represents the activation energy barrier?
 - a. a
 - b. b
 - c. c
 - d. d
3. Which statement best describes the reaction?
 - a. The reaction is exothermic in the forward reaction.
 - b. The reaction is endothermic in the forward reaction.
 - c. The reaction is exothermic in the reverse reaction.
 - d. The reaction is exothermic only at high temperatures.
4. Which letter represents the change in enthalpy for the reaction?
 - a. b
 - b. c
 - c. d
 - d. e
5. Which letter represents the activated complex for the reaction?
 - a. a
 - b. b
 - c. c
 - d. d
6. What is an activated complex?
 - a. a transitional species that can eventually be isolated
 - b. a transitional species of that must be made before the products can be formed
 - c. a reactant molecule breaking into a product molecule
 - d. part of the activation energy barrier
7. For the following reaction, the activation energy is 60 kJ: $A_{2(g)} + 2 B_{(g)} \rightarrow 2 AB_{(g)}$. Draw a potential energy diagram properly labeling the following:

- a. the axes
- b. the reactants and products
- c. the activation energy
- d. the enthalpy

18.4 Factors That Affect Reaction Rates

Lesson Objectives

The student will:

- describe how temperature, concentration, surface area, and the addition of a catalyst affect the rate of a chemical reaction.
- define a catalyst and describe how it affects the potential energy diagram of a reaction.
- identify a catalyst in chemical equations.

Vocabulary

- catalyst
- effective collision

Introduction

Chemists use reactions to generate a desired product. For the most part, a reaction is only useful if it occurs at a reasonable rate. For example, a reaction that took 8,000 years to complete would not be a desirable way to produce brake fluid. However, a reaction that proceeded so quickly that it caused an explosion would also not be useful (unless the explosion was the desired result). For these reasons, chemists wish to be able to control reaction rates. In order to gain this control, we must first know what factors affect the rate of a reaction. We will discuss some of these factors in this section.

Effect of Temperature on Rate of Reaction

Increased Temperature

The rate of reaction was discussed in terms of three factors: collision frequency, the collision energy, and the geometric orientation. Remember that the collision frequency is the number of collisions per second. The collision frequency is dependent, among other factors, on the temperature of the reaction.

When the temperature is increased, the average velocity of the particles is increased. As a result, the average kinetic energy of these particles is also increased. The result is that the particles will collide more frequently because the particles move around faster and will encounter more reactant particles, but this is only a minor part of the reason why the rate is increased. Just because the particles are colliding more frequently does not mean that the reaction will definitely occur.

The major effect of increasing the temperature is that more of the particles that collide will have the amount of energy needed to have an **effective collision**, or a collision that results in a reaction. In other words, more particles

will have the activation energy needed to overcome the activation energy barrier and form the activated complex. The effect of raising the temperature, therefore, is to produce more activated complexes. With the greater number of activated complexes that are formed, the faster the rate of reaction.

At room temperature, the hydrogen and oxygen in the atmosphere do not have sufficient energy to attain the activation energy needed to produce water.

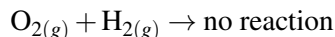

At any one moment in the atmosphere, there are many collisions occurring between these two reactants. When this reaction does occur, it is exothermic, which tends to mean that the reaction should occur. We find, however, that water does not form from the oxygen and hydrogen molecules colliding in the atmosphere because the activation energy barrier is just too high, causing all the collisions to rebound. When the necessary energy is supplied to the molecules, the molecules overcome the activation energy barrier, the activated complex is formed, and water is produced:

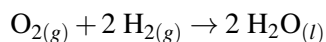

Decreased Temperature

There are times when the rate of a reaction needs to be slowed down. Using the factors as specified previously, one of ways to accomplish this would be to keep the reactants in separate containers so that there can be no collisions between the particles. At times that might not be practical, so lowering the temperature could also be used to decrease the number of collisions that would occur and to reduce the kinetic energy available for activation energy. If the particles have insufficient activation energy, the collisions will result in rebounds rather than reaction. Using this idea, when the rate of a reaction needs to be lower, keeping the particles from having sufficient activation energy will keep the reaction at a lower rate.

A Generalization for Increased Temperature

The rate of most reactions can be dramatically increased with increased temperature. For reactions that normally occur at room temperature, a general rule of thumb is that for every increase of 10°C , the rate will be doubled. If the temperature for these reactions is increased by 20°C , the rate will be increased by a factor of 4; increasing the temperature by 40°C , the rate will be increased by a factor to 16. For any specific reaction, however, the actual rate increase will have to be determined by experimentation.

Examples of Temperature on Reaction Rate

Society uses the effect of temperature on reaction rate every day. Food storage is a prime example of how the temperature effect on reaction rate is utilized by society. Consumers store food in freezers and refrigerators to slow down the processes that cause it to spoil. The decrease in temperature decreases the rate at which the food will break down or be broken down by bacteria.

When milk, for instance, is stored in the refrigerator, the molecules in bacteria have less energy. This means that while molecules will still collide with other molecules, few of them will react because the molecules do not have sufficient energy to overcome the activation energy barrier. Bacterial growth in milk is slowed down because the cellular molecules do not have enough energy to undergo chemical reactions crucial to cell reproduction. If that same carton of milk was at room temperature, the milk would react (in other words, spoil) much more quickly. Now most of the molecules will have sufficient energy to overcome the energy barrier, and at room temperature, many more collisions will be occurring. This allows for the milk to spoil in a fairly short amount of time.

For a classroom demonstration of the effect of temperature on reaction rate (**8b**), see <http://www.youtube.com/watch?v=t0x10CXjB04> (4:41).

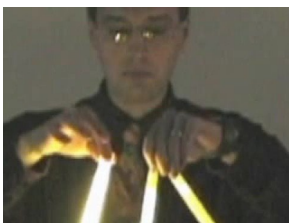

MEDIA

Click image to the left for more content.

Effect of Concentration

Increasing Concentration

If you had one red ball and one green ball flying around randomly in an enclosed space and undergoing perfectly elastic collisions with the walls and with each other, in a given amount of time, the balls would collide with each other a certain number of times as determined by probability. If you now put two red balls and one green ball in the room under the same conditions, the probability of a collision between a red ball and the green ball would exactly double. The green ball would have twice the chance of encountering a red ball in the same amount of time.

In terms of chemical reactions, a similar situation exists. Particles of two gaseous reactants or two reactants in solution have a certain probability of undergoing collisions with each other in a reaction vessel. If you double the concentration of either reactant, the probability of a collision doubles. The rate of reaction is proportional to the number of collisions per unit time. Assuming that the percent of successful collision does not change, then having twice as many collisions will result in twice as many successful collisions. The rate of reaction is proportional to the number of collisions per unit time, so increasing the concentration of either reactant increases the number of collisions, the number of successful collisions, and the reaction rate.

Some reactions occur by a single collision between two reactant molecules, while other reactions occur by a series of collisions between multiple reactant particles. We will consider the case of the single step now and the case of the multiple step reactions later in the chapter.

The rate of a single collision chemical reaction at a given temperature can be expressed as a product of the concentrations of the reactants. For the reaction $A_{(g)} + B_{(g)} \rightarrow AB_{(g)}$, the reaction rate can be expressed as:

$$\text{Rate} = k[A][B]$$

where k is a constant for the reaction called the reaction constant and $[A]$ and $[B]$ are the molarities of the reactants.

If only the concentration of A is doubled, the equation would become $\text{Rate} = k[2A][B]$, and the rate would double the previous rate.

If only the concentration of B is doubled, the equation would become $\text{Rate} = k[A][2B]$, and once again the rate would double the previous rate.

If the concentrations of both A and B are doubled, the equation becomes $\text{Rate} = k[2A][2B]$, and the rate would now be four times the original rate.

Experimental Determination of Reaction Rate

When the reaction involves a series of collisions, the relationship between the reaction rate and the concentration of any single reaction can only be determined by a laboratory procedure. Consider the reaction below between NO_2

and CO. This reaction does not occur by a single collision but rather in a two step process.

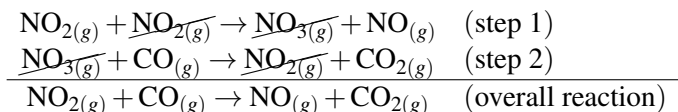

The effect of the concentration of a reactant on the rate of this multiple step reaction can only be known through experimentation. Let's look at one experiment in order to determine how the concentration of the reactants affects the rate of the reaction.

Example:

For the hypothetical reaction $A + B \rightarrow C + D$, the following data (**Table 18.1**) was collected in an experiment to attempt to determine the effect of increasing the concentration of the reactants on the rate.

TABLE 18.1: Sample Data

Trial	[A] (mol/L)	[B] (mol/L)	Rate (mol/L · s)
1	1.0	1.0	5.0×10^{-3}
2	2.0	1.0	5.0×10^{-3}
3	1.0	2.0	$10. \times 10^{-3}$

Determine the effect of increasing the [A] and increasing [B] on the rate of the reaction.

Solution:

Step 1: Try to find two trials where the concentration of A is changing while the concentration of B remains the same.

In this case, in trials 1 and 2, [A] changes while [B] remains constant. Since [A] is changing and [B] is staying the same, any change in the reaction rate would be due to the change in [A].

Step 2: Determine the effect of changing the concentration of A on the reaction rate.

From trial 1 to trial 2, the concentration of A has doubled. The reaction rate in these two trials, however, did not change.

Therefore, the concentration of A has no effect on the rate for this reaction.

Step 3: Try to find two trials in which [B] changes while [A] stays the same.

In trials 1 and 3, the concentration of B changes while A stays the same. From trial 1 to trial 3, the concentration of B doubles. The reaction rate also doubled between these two trials. When the concentration of B doubled, the reaction rate also doubled. Therefore, we can conclude that the reaction rate is directly proportional to the concentration of B.

Therefore, when the concentration of A is increased, there is no effect on the rate of the reaction. When the concentration of B is doubled, the rate is doubled. In other words, increasing the concentration of B increases the rate.

Example of the Effect of Concentration on Reaction Rate

The chemical test used to identify a gas as oxygen relies on the fact that increasing the concentration of a reactant increases reaction rate. The reaction we call combustion refers to a reaction in which a flammable substance reacts with oxygen. If we light a wooden splint (a thin splinter of wood) on fire and then blow the fire out, the splint will continue to glow in air for a period of time. If we insert that glowing splint into any gas that does not contain oxygen, the splint will immediately cease to glow - that is the reaction stops. Oxygen is the only gas that will support

combustion. Air is approximately 20% oxygen gas. If we take that glowing splint and insert it into pure oxygen gas, the reaction will increase its rate by a factor of five since pure oxygen has 5 times the concentration of oxygen that is in air. When the reaction occurring on the glowing splint increases its rate by a factor of five, the glowing splint will suddenly burst back into full flame. This test of thrusting a glowing splint into a gas is used to identify the gas as oxygen. Only a greater concentration of oxygen than that found in air will cause the glowing splint to burst into flame.

Effect of Surface Area

The Relationship Between Surface and Reaction Rate

Consider a reaction between reactant red and reactant blue, where reactant blue is in the form of a single lump (**Figure A** below). Then compare this to the same reaction where reactant blue has been broken up into many smaller pieces (**Figure B** below).

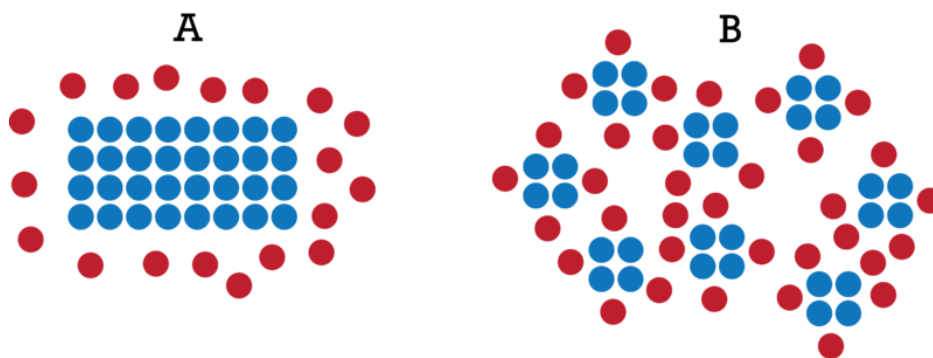

In **Figure A**, only the blue particles on the outside surface of the lump are available for collision with reactant red. The blue particles on the interior of the lump are protected by the blue particles on the surface. If you count the number of blue particles available for collision, you will find that only 20 blue particles could be struck by a particle of reactant red. In **Figure B**, however, the lump has been broken up into smaller pieces, and all the interior blue particles are now on a surface and available for collision. As a result, more collisions between blue and red will occur. The reaction in **Figure B** will occur at faster rate than the same reaction in **Figure A**. Increasing the surface area of a reactant increases the frequency of collisions and increases the reaction rate.

You can see an example of this in everyday life if you have ever tried to start a fire in the fireplace. If you hold a match up against a large log in an attempt to start the log burning, you will find it to be an unsuccessful effort. Flammable materials like wood require a significant input of activation energy for the reaction to occur. The reaction between wood and oxygen is an exothermic reaction, so once the fire has been started, the heat released by the first reactions will provide the activation energy for the succeeding reactions. However, holding a match against a large log will not cause enough reactions to occur to keep the fire going. Instead, the log needs to be broken up into many small, thin sticks called kindling. These thinner sticks of wood provide many times the surface area of a single log. Now a match will be able to cause enough reactions in the kindling to successfully start a fire.

There have been, unfortunately, cases where serious accidents were caused by the failure to understand the relationship between surface area and reaction rate. One such example occurred in flour mills. A grain of wheat is not very flammable, but if the grain of wheat is pulverized and scattered through the air, only a spark is needed to cause an explosion. A small spark then is sufficient to start a very rapid reaction that can destroy the entire flour mill. In a 10-year period from 1988 to 1998, there were 129 grain dust explosions in mills in the United States. Flour mills now have huge fans to help circulate the air in the mill through filters in order to remove the majority of the flour dust particles. Coal mines suffer a similar problem. In coal mines, huge blocks of coal must be broken up by drilling

before the coal can be brought out of the mine. This drilling produces fine coal dust that mixes into the air, and a spark from a tool can cause a massive explosion in the mine. In modern coal mines, lawn sprinklers are used to spray water through the air in the mine in order to reduce the coal dust in the air.

Examples

You can observe the effect of surface area in the following manner: take two solids, put them together, and observe the reaction, then as a comparison, put one of these solids into solution, add the other solid, and observe the reaction. For example, if you were to take a few grams of copper(II) chloride and place them into a beaker along with a piece of aluminum foil, it would take a numbers days, if not weeks, before you would observe any significant changes. However if you were to make a solution of the copper(II) chloride before adding the aluminum foil, you would observe an almost immediate reaction. In this case, the surface area of only one of the reactants was changed, but that change would dramatically affect the rate of reaction because the copper(II) chloride ions could individually interact with the atoms present in the aluminum foil.

Effect of a Catalyst

The final factor that affects the rate of the reaction is the presence of a catalyst. A **catalyst** is a substance that speeds up the rate of the reaction without itself being consumed by the reaction. There are a number of different catalysts, such as surface catalysts, which merely provide a surface for intermediate products to adhere to, and catalysts that are used at the beginning of a reaction but are completely reproduced at the end. The substances called enzymes in biology are catalysts that help carry out numerous chemical reactions in the body. Many commercial preparations of chemicals for industry rely on catalysts to prepare their products in a more cost effective manner. For example, iron oxide or vanadium oxide is used in combination with platinum as surface catalysts in the production of sulfuric acid (H_2SO_4).

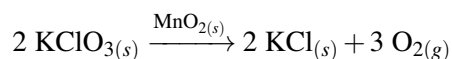

The catalyst manganese dioxide makes the above reaction occur much faster than it would occur by itself under standard conditions. When the reaction has reached completion, the MnO_2 can then be removed from the reaction vessel in the same condition as it was before the reaction.

A Catalyst is Not a Reactant

It is important to emphasize that a catalyst is a substance that speeds up the rate of the reaction but is itself not consumed by the reaction. In other words, the catalyst is not seen in the reaction as either a reactant or a product. Consider the reaction to produce sulfuric acid again:

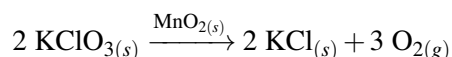

The reaction above is very slow unless you add manganese dioxide as a catalyst. Manganese dioxide is a black powder, while potassium chlorate is a white powder. After heating the potassium chlorate and obtaining the oxygen gas at the end of the reaction, all of the black MnO_2 can be recovered. You should note that the catalyst is not written into the equation as a reactant or product but is noted above the yields arrow. This is standard notation for a catalyst.

Look at the following three-step process below:

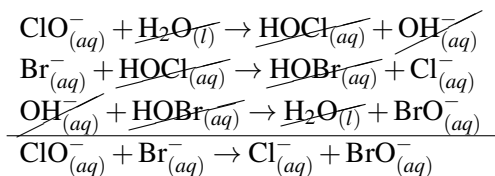

In this three-step process, all of the reactions are added together, and substances that appear on both sides of the equation are eliminated before writing the final overall equation. Notice how $\text{H}_2\text{O}_{(l)}$ is consumed in the first equation of the sequence and then produced in the final equation of the sequence. Since $\text{H}_2\text{O}_{(l)}$ is consumed and then produced, it is a catalyst. The presence of the water molecule causes this reaction to occur at a higher rate than it will occur without the presence of water. Therefore, although water is used in the reaction, it is reproduced so that the total amount of water is available at the end. This is also the behavior of a catalyst.

Catalysts Provide a Different Path with Lower Activation Energy

Some reactions occur very slowly without the presence of a catalyst. In other words, the activation energy for these reactions is very high. When the catalyst is added, the activation energy is lowered because the catalyst provides a new reaction pathway with lower activation energy.

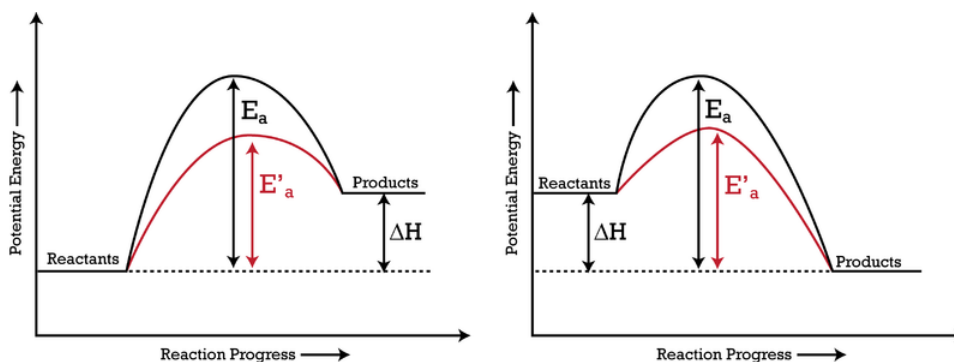

Remember that the catalyst does not get consumed in the reaction, so the reactants and products positions are not affected by the addition of the catalyst. In the left figure above, the endothermic reaction shows the catalyst reaction in red with lowered activation energy, designated E'_a . The new reaction pathway has lower activation energy, but it has no effect on the energy of the reactants, the products, or the value of ΔH .

The same is true for the exothermic reaction in the figure on the right. The activation energy of the catalyzed reaction (again designated by E'_a) is lower than that of the reaction without a catalyst. The new reaction pathway provided by the catalyst for the exothermic reaction shown in the right figure affects the energy required for reactant bonds to break and product bonds to form.

These two videos discuss the factors affecting reaction rate (**8b**, **8c**, **8d**). The first video discusses factors affecting reaction rate and the second one is a humorous example of a catalyzed reaction: http://www.youtube.com/watch?v=1iFMRsU_Nlo (9:45), <http://www.youtube.com/watch?v=ezsur0L0L1c> (0:35).



MEDIA

Click image to the left for more content.



MEDIA

Click image to the left for more content.

This video described the role of biological catalysts called enzymes. It also looks at the factors that affect the action of enzymes (**11 IE Stand.**): <http://www.youtube.com/watch?v=jSc8nMbrGNc> (0:35).



MEDIA

Click image to the left for more content.

Surface Catalysts and Enzymes

An example of a surface catalyst is platinum, which acts as a surface catalyst in the reaction where hydrogen and oxygen form water.

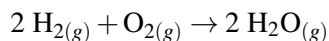

This reaction is so slow that under standard conditions, it essentially doesn't occur. This is why the hydrogen and oxygen gases in our atmosphere do not react with each other. Even if hydrogen and oxygen gases are mixed in a reaction vessel, no reaction occurs. This reaction has a very high activation energy requirement, and standard conditions simply do not provide sufficient energy for the reaction to occur. In comparison, if a piece of platinum is dropped into a small container of hydrogen and oxygen gas at room conditions, a small explosion occurs as this reaction goes to completion almost immediately.

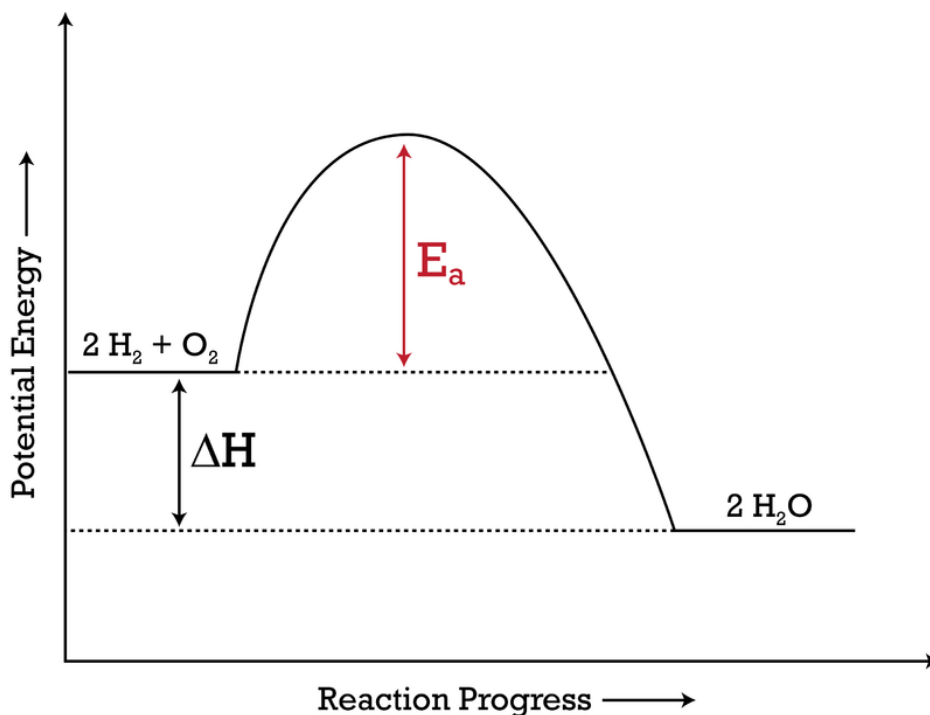

In order for hydrogen gas and oxygen gas to react without a catalysis, all the reactant particles need to collide in a single collision with enough activation energy to break the bond in both the hydrogen molecules *and* break the double bond in the oxygen molecule. Under standard conditions, these particles are not nearly energetic enough for a collision to provide that much activation energy, so no reaction occurs.

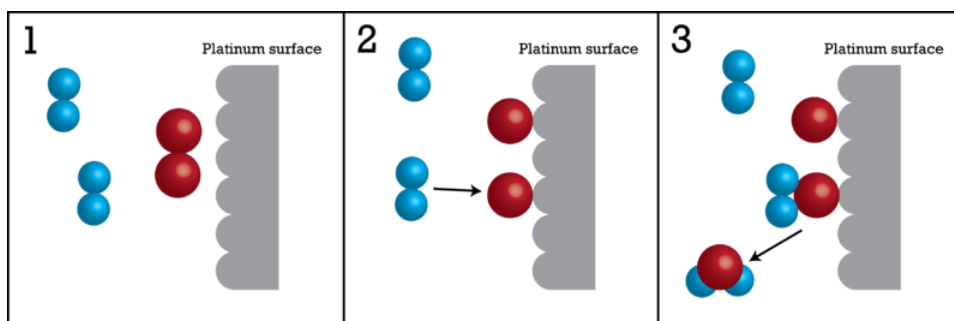

If a platinum surface is available, the oxygen molecules can strike the platinum surface, thus breaking the bond holding the oxygen atoms together. The oxygen atoms then adhere to the surface of the platinum. This collision requires less energy than the collision necessary when platinum is not present. Later, a hydrogen molecule can collide with one of the oxygen atoms adhering to the platinum surface. This collision breaks the bond in the hydrogen molecule so that the hydrogen and oxygen can combine and leave the surface of the platinum. Eventually, another hydrogen molecule repeats this process with the final oxygen atom. When all the oxygen atoms have left the surface of the platinum, the platinum is exactly the same as it was before the reaction. In this way, the reaction has occurred with several smaller collisions rather than one large one. Therefore, in the presence of a platinum catalyst, this reaction will occur at room temperature. The reaction rate has been significantly increased. The fact that the platinum increases the reaction rate but is not permanently consumed qualifies it as a catalyst in this reaction.

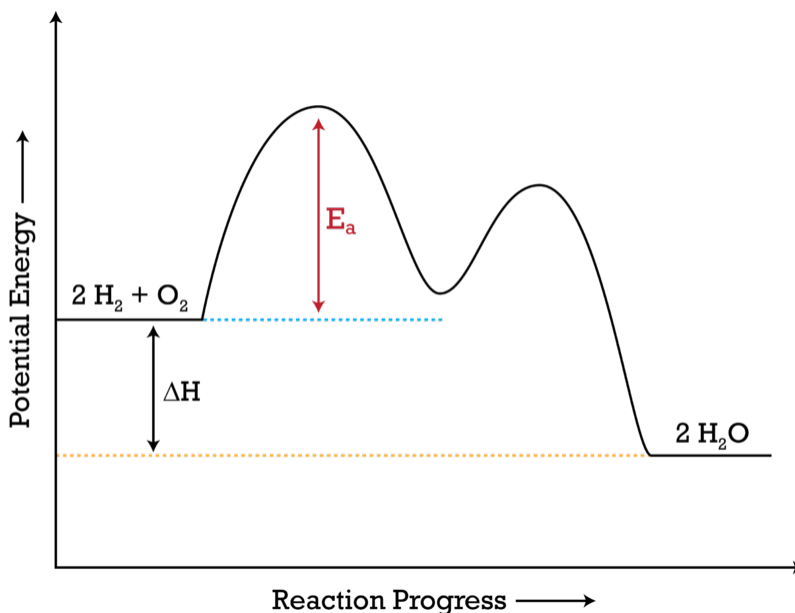

In the potential energy diagram, the reactants and products are exactly the same as before because it is the same reaction. Since the products and reactants are the same, they have the same enthalpy stored in their bonds, so ΔH will be exactly the same for both reactions. What has changed is the energy barrier. The reaction mechanism for the catalyzed reaction is different, as the reaction does not occur by the same process. The catalyst provides a different reaction path for the same reaction, and the new path has a lower activation energy requirement. The lower activation energy allows for a much faster reaction rate.

Lesson Summary

- An increase in temperature results in an increase in reaction rate because there is an increase in the number of collisions (minor factor) and the number of particles that have sufficient energy to overcome the activation barrier. A decrease in temperature has the opposite effect.
- A rule of thumb used for the effect of temperature on the rate is that if the temperature is increased by 10°C, the rate is doubled.
- Increasing the concentration of a reactant increases the frequency of collisions between reactants and will increase the reaction rate.
- Increasing the surface area of a reactant increases the number of particles available for collision and will increase the number of collisions between reactants per unit time.
- Increasing the frequency of collisions increases the reaction rate.
- The catalyst is a substance that speeds up the rate of the reaction without itself being consumed by the reaction. The catalyst provides a new reaction pathway with lower activation energy.
- The new reaction pathway has lower activation energy, but this has no effect on the energy of the reactants, the products, or the value of ΔH .

Further Reading / Supplemental Links

The *learner.org* website allows users to view streaming videos of the Annenberg series of chemistry videos. You are required to register before you can watch the videos, but there is no charge. The website has two videos that relate to this lesson called “Molecules in Action” and “On the Surface.”

- <http://learner.org/resources/series61.html>

This video is a ChemStudy film called “Teacher Training for Catalysis.” The film is somewhat dated, but the information is accurate.

- <http://www.youtube.com/watch?v=9SigDuaQOpo>

Review Questions

1. Why does an increase in temperature increase the rate of the reaction?
2. Why does higher temperature increase the reaction rate?
 - a. more of the reacting molecules will have higher kinetic energy
 - b. increasing the temperature causes the reactant molecules to heat up
 - c. the activation energy will decrease
 - d. increasing the temperature causes the potential energy to decrease
3. When the temperature is increased, what does not change?
 - a. number of collisions
 - b. activation energy requirement
 - c. number of successful collisions
 - d. all of the above change
4. What is the rule of thumb used for the temperature dependence on the rate?

- The rule of thumb for the temperature effect on reaction rates is that a reaction rate will double for each 10°C rise in temperature. The rate of reaction for a hypothetical reaction was found to be 0.62 mol/L · s at 6°C. What would be the rate at 46°C?
- Explain how concentration affects reaction rate using the collision theory. You may want to include a diagram to help illustrate your explanation.
- Why is the increase in concentration directly proportional to the rate of the reaction?
 - The kinetic energy increases.
 - The activation energy increases.
 - The number of successful collisions increases.
 - All of the above.
- For the reaction $\text{H}_{2(g)} + \text{Cl}_{2(g)} \rightarrow 2 \text{HCl}_{(g)}$, an experiment shows that if the concentration of $\text{H}_{2(g)}$ is doubled, the rate of reaction stays the same. If the concentration of $\text{Cl}_{2(g)}$ doubles, the rate of the reaction quadruples. What is the explanation for this observation?
 - The reaction is nearing completion and all $\text{H}_{2(g)}$ is used up.
 - The reaction occurs in more than one step.
 - Excess $\text{Cl}_{2(g)}$ has been added.
 - Not enough information is given.
- The mechanism for a reaction is as follows:



Which of the following would have the greatest effect on the rate of reaction?

- Increase [NO]
 - Increase [Br₂]
 - Increase [NOBr₂]
 - Increase [NO] and [Br₂]
- Consider the following reaction mechanism. For which substance would a change in concentration have the greatest effect on the rate of the overall reaction?



- A, B, C
 - A
 - B
 - C
- The following data (**Table 18.2**) were obtained for the decomposition of N_2O_5 in $\text{CCl}_4(aq)$ at 45°C. Determine the effect of decreasing the $[\text{N}_2\text{O}_5]$ on the rate of the reaction.

$$\begin{aligned} \frac{[\text{N}_2\text{O}_5]_{\text{trial 2}}}{[\text{N}_2\text{O}_5]_{\text{trial 1}}} &= \frac{0.274}{0.316} = 0.867 \\ \frac{\text{rate}_{\text{trial 2}}}{\text{rate}_{\text{trial 1}}} &= \frac{0.34}{0.39} = 0.87 \end{aligned}$$

TABLE 18.2:

Trial	N_2O_5 mol/L	Rate(mol/L · s)
1	0.316	0.39
2	0.274	0.34
3	0.238	0.29
4	0.206	0.25
5	0.179	0.22

12. Why, using the collision theory, do reactions with higher surface area have faster reaction rates?
13. Choose the substance with the greatest surface in the following groupings:
- a block of ice or crushed ice
 - sugar cubes or sugar crystals
 - a piece of wood or wood shavings
 - $\text{O}_2(s)$ or $\text{O}_2(g)$
 - $\text{AgNO}_3(s)$ or $\text{AgNO}_3(aq)$
14. Lighter fluid is sometimes used to get a barbecue coals to begin to burn. Give a complete explanation for
- the purpose of the lighter fluid; and,
 - the purpose of the coals.
15. Draw a potential energy diagram for an exothermic reaction labeling the following:
- the activation energy of 125 kJ
 - the enthalpy of -85 kJ/mol
 - the reactants and product
 - the axes
 - the activation energy for the catalyzed reaction
16. The main function of a catalyst is to
- provide an alternate reaction pathway
 - change the kinetic energy of the reacting particles
 - eliminate the slow step
 - add another reactant
17. What happens when a catalyst is added?
- the activation energy of the forward reaction is lowered
 - the activation energy of the reverse reaction is lowered
 - the activation energy in general is lowered
 - the enthalpy of the reaction is lowered
18. Given the reaction mechanism shown below, which species is the catalyst?

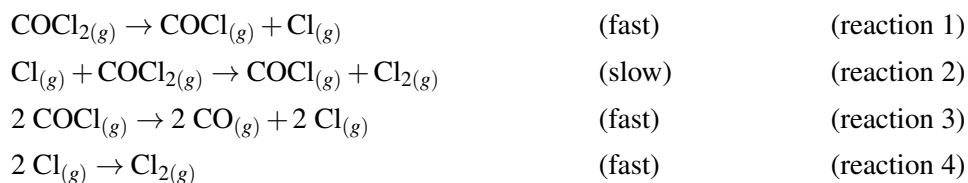

- $\text{CO}(g)$
- $\text{COCl}_2(g)$
- $\text{COCl}(g)$
- $\text{Cl}(g)$

19. Catalysts are used in all parts of society from inside our bodies to the largest industries in the world. Give an example of a catalyst and explain its usefulness.

18.5 Multi-step Reaction

Lesson Objectives

The student will:

- define multi-step reaction and reaction mechanism.
- identify the rate-determining step.
- draw a potential energy diagram for a multi-step reaction.

Vocabulary

- elementary step
- multi-step mechanism
- rate-determining step
- reaction mechanism

Introduction

In the last section, the uncatalyzed reaction between hydrogen and oxygen was compared to a catalyzed reaction between the same two reactants. Without a catalyst, all three particles needed to collide at the same time with sufficient energy to break all the bonds in all the molecules, giving the reaction a very high activation energy. The catalyzed reaction could occur because it allowed for a series of collisions where the bonds could be broken one at a time, thus requiring less activation energy.

Complicated reactions involving many bonds and many molecules do not occur in single collisions. These reactions instead occur in a series of collisions. Each collision in the series produces an *intermediate* product that undergoes further collisions until the final products are produced. This long series of collisions producing intermediate products is called a **multi-step reaction**.

The reaction below is an example of a multi-step reaction. Nitrogen dioxide and carbon monoxide react in a two-step process to form nitrogen monoxide and carbon dioxide. The two steps making up the **reaction mechanism**, which describes what occurs for each stage in the reaction, is shown below.

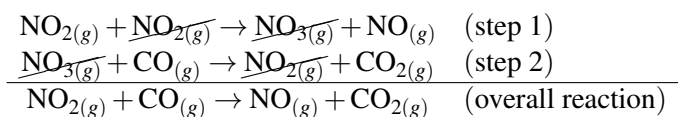

In this lesson, we will discuss multi-step reactions, as well as the individual reactions in the multi-step process.

Most Reactions Have Multi-Steps

In complicated reactions, the overall reaction will take place in a series of single steps, often called elementary steps. An **elementary step** is a single, simple step in a multi-step process. An elementary step almost always involves only two particles. The series of elementary steps outline the process of the reaction. Most reactions do not take place in one step but rather as a combination of two or more elementary steps. This series of steps is referred to as a multi-step reaction.

The rate of reaction is dependent on the reactants in the slowest step of the multi-step process. If we look at the reaction from the introduction again, it appears to be a two particle collision between $\text{NO}_{2(g)}$ and $\text{CO}_{(g)}$, yet it is known that the rate is only affected by the concentration of $\text{NO}_{2(g)}$. This indicates that the reaction proceeds by way of a multi-step process.

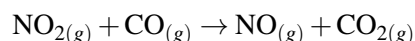

Example:

Which of the following reactions would most likely involve a multi-step reaction? Explain.

- $2 \text{I}^- + \text{S}_2\text{O}_8^{2-} \rightarrow \text{I}_2 + 2 \text{SO}_4^{2-}$
- $\text{Cl}_{2(g)} \rightarrow 2 \text{Cl}_{(g)}^-$

Solution:

- multi-step reaction; three reactant particles are present
- elementary step; only one reactant particle is present

Each Step Has Its Own Activated Complex

When there is a single step reaction, we can draw potential energy diagrams like the ones we have seen earlier in this chapter. For a multi-step process where two or more elementary steps combine to form the net reaction, the potential energy diagram looks quite different. Look at the reaction below. This mechanism is involved in the depletion of the ozone layer.



The overall reaction is $\text{O}_{3(g)} + \text{O}_{(g)} \rightarrow 2 \text{O}_{2(g)}$.

If we were to draw the potential energy diagram for this two-step process, it would look like the figure below. Notice that for each reaction in the multi-step process, there is an activation energy barrier. Therefore, E_{a1} is the activation energy associated with reaction 1, and E_{a2} is the activation energy associated with reaction 2. The slow step has an activation energy barrier that is higher than that of the faster reaction.

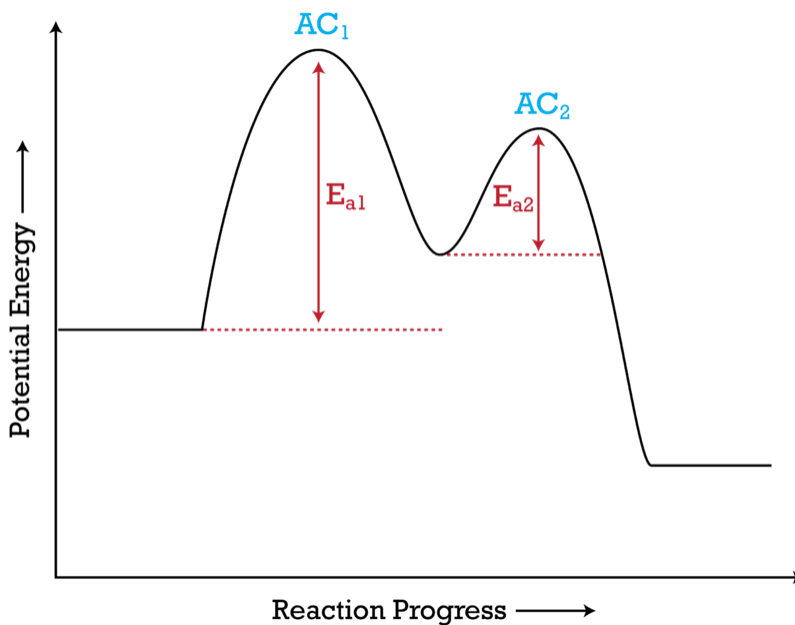

Each reaction also has its own activated complex. Remember that at the top of the activation energy barrier is the activated complex, the transition state between reactants and products that has the most potential energy. AC_1 is the complex created in the first reaction, while AC_2 is the activated complex created in the second reaction. Thus, for this two-step process, there are two activated complexes.

Example:

Draw the potential energy diagram for the following multi-step reaction ($\Delta H < 0$). Properly label the diagram.



Solution:

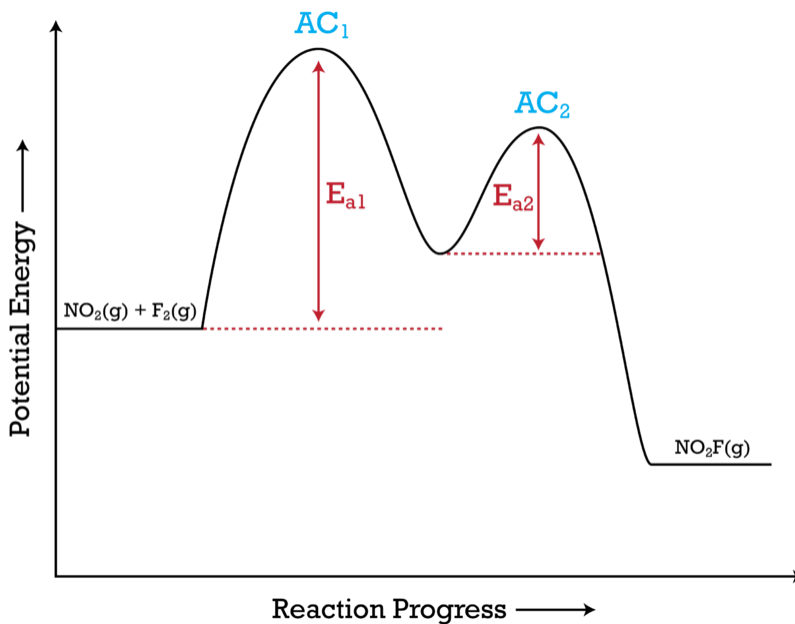

Rate of Reaction is Determined by Slowest Step

In a series of reactions that make up a multi-step reaction, each individual reaction step has its own reaction rate that is determined by the factors that have been discussed in this chapter. The overall reaction rate for the overall reaction (the sum of all the individual steps) can be determined from the rates of the individual steps. The relationship between the overall rate and the individual rates, however, is not what you might expect. The overall rate is not the sum or the average of the individual rates. In fact, the overall rate for the reaction is *exactly the same as the rate of the slowest step*. Let's look at an example from life to see how this occurs.

Suppose you and two of your friends organize a car wash. You set up an assembly line operation where the cars at station 1 are wetted with a hose, cars at station 2 are washed with soapy water and rinsed, and cars at station 3 are towel dried.

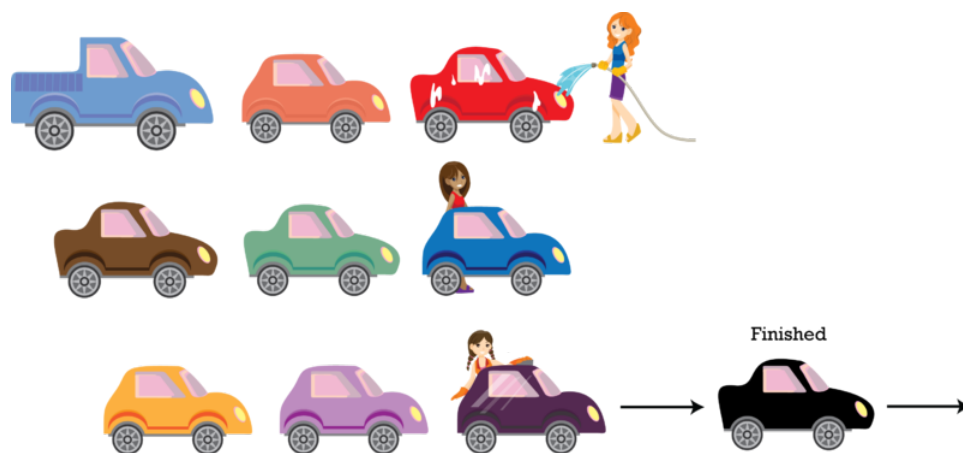

Suppose your job is to wet the cars, which takes 3 minutes to accomplish. The job of washing at station 2 takes 18 minutes, and the drying job requires 14 minutes. When the car is done at a station, the car gets in line for the next station. In order to evaluate the efficiency of your assembly line, you count the minutes between the finished cars coming off the end of the line. The time lapse between completed cars is your reaction rate.

Regardless of what appears in the picture above, you should realize that there will be no cars in line for station 3. Each car requires 18 minutes at station 2, and when the cars move to station 3, another car immediately goes to station 2. The drying of the first car and the washing of the second car begin at exactly the same time. Since it takes 18 minutes to wash and 14 minutes to dry, the car at station 3 is always finished and gone 4 minutes before the car at station 2. Therefore, the worker at station 3 is always standing around and waiting for 4 minutes before the next car is ready to be dried. The time between cars coming off the line will be the 4 minutes the station 3 worker waits plus the 14 minutes required to dry, so the time between cars will be 18 minutes. The reaction rate for this arrangement will be 18 minutes. You should note that this overall reaction rate is exactly the same as the slowest step in the process, namely the wash step at station 2.

Suppose you bring in another person to work on your car wash and you assign that person to station 2 so that you have two people washing cars. The time to wash a car now becomes only 9 minutes since you have doubled the work force. The wash process now will finish before the drying process, so cars will back up in line for station 3. The drying stage is now the slowest step. Therefore, when the worker at station 3 finishes drying a car, another car immediately enters station 3 for the worker to begin drying. With this new organization, the time lapse between cars coming out will now be 14 minutes. The overall reaction rate is faster. The important point is that the slowest step takes 14 minutes, and the overall rate is 14 minutes.

Let's look at another important point about this concept. We will go back to the original set up with a 3 – minute wetting (station 1), an 18 – minute washing (station 2), and a 14 – minute drying (station 3). Suppose when the first extra worker was brought in, you assigned that person to help with the drying so that the drying time is now

7 minutes. What would the overall rate be? The overall rate is exactly the same as the slowest step, and the slowest step is still the 18 – minute washing time. Therefore, you have increased the rate of the drying step, but you have *not* affected the overall reaction rate. The only way you can alter the overall reaction rate is to increase the rate of the slowest step. Increasing the rate of steps other than the slowest step does nothing to the overall rate.

In chemical reactions, the speed of the other steps is so much faster than the slowest step that the slowest step is referred to as the **rate-determining** step. It is the speed of this slowest step that determines the rate of the overall reaction, so changing the concentrations of the reactants in this step will change the rate.

Example:

In the multi-step reaction below, identify the rate-determining step and write the overall reaction.

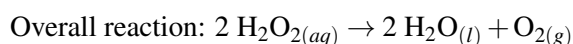
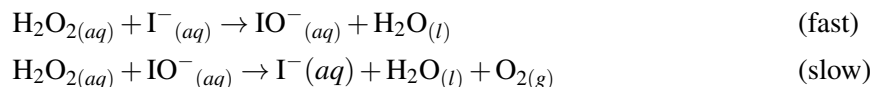

The overall reaction is found by adding the two elementary steps together and canceling identical species that appear on both sides of the chemical equation, which in this case are $\text{I}^-_{(aq)}$ and $\text{IO}^-_{(aq)}$.

Solution:

The slow step (reaction 2) is the rate-determining step. Whatever the reaction rate is for reaction 2, the overall rate will be exactly the same.

Lesson Summary

- A multi-step reaction is a combination of two or more elementary steps.
- An elementary step is a single, simple step involving one or two particles.
- The rate-determining step is the slowest step in a multi-step reaction, and the overall reaction rate will be exactly the same as the rate of the slowest step.

Further Reading / Supplemental Links

The following is a video lecture on reaction mechanism.

- http://www.youtube.com/watch?v=-ctr9MUM_hI

Review Questions

1. Why do most reactions take place in more than one step?
2. The overall rate of a reaction depends on
 - a. the temperature
 - b. the surface area
 - c. the pressure
 - d. the slowest step

3. Suppose a reaction takes place according to the following reaction mechanism. Determine which step in the mechanism is the rate-determining step.

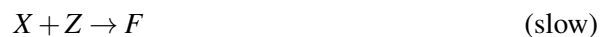

4. If you wanted to increase the overall rate of the reaction in Question #3, would you increase the concentration of X or Y ? Explain
5. Consider the following equation for the formation of ammonia. Explain why this equation is not likely to represent the reaction mechanism.

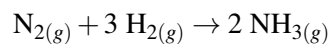

All images, unless otherwise stated, are created by the CK-12 Foundation and are under the Creative Commons license CC-BY-NC-SA.

Chapter Outline

- 19.1 INTRODUCTION TO EQUILIBRIUM**
 - 19.2 EQUILIBRIUM CONSTANT**
 - 19.3 THE EFFECTS OF APPLYING STRESS TO REACTIONS AT EQUILIBRIUM**
 - 19.4 SLIGHTLY SOLUBLE SALTS**
-

19.1 Introduction to Equilibrium

Lesson Objectives

The student will:

- describe what is happening in a system at equilibrium.
- explain what is meant by dynamic equilibrium.
- state the conditions necessary for a system to be in equilibrium.

Vocabulary

- dynamic equilibrium
- equilibrium
- irreversible reaction
- macroscopic properties
- reversible reaction

Introduction

Consider this generic reaction: $A + B \rightarrow C + D$. Based on what we have learned so far, you might assume that the reaction will keep going forward, forming C and D until either A or B (or both) is completely used up. When this is the case, we would say that the reaction “goes to completion.” Reactions that go to completion are referred to as **irreversible reactions**.

Some reactions, however, are reversible, meaning that products can also react to re-form the reactants. In our example, this would correspond to the reaction $C + D \rightarrow A + B$. During a **reversible reaction**, both the forward and backward reactions are happening at the same time.

Equilibrium

As we learned earlier, the rate of a reaction depends on the concentration of the reactants. At the very beginning of the reaction $A + B \rightarrow C + D$, we would not expect the reverse reaction to proceed very quickly. If only a few particles of C and D have been created in a large flask of A and B , then it is very unlikely that they will find each other because the concentration of C and D is just too low. If C and D cannot find each other and collide with the correct energy and orientation, no reaction will occur.

However, as more and more C and D are created, it becomes more and more likely that they will find each other and react to re-form A and B . Conversely, as A and B are being used up, the forward reaction slows down for the same exact reason. The concentration of A and B decreases over the course of a reaction because there are less A and B

particles in the same size flask. At some point, the rates for the forward and reverse reactions will be equal, at which point the concentrations will no longer change. If A and B are being destroyed at the same rate that they are being created, the overall amount should not change over time. At this point, the system is said to be in **equilibrium**. A qualitative description of this process for the reaction between hydrogen and sulfur to make dihydrogen sulfide is shown below.

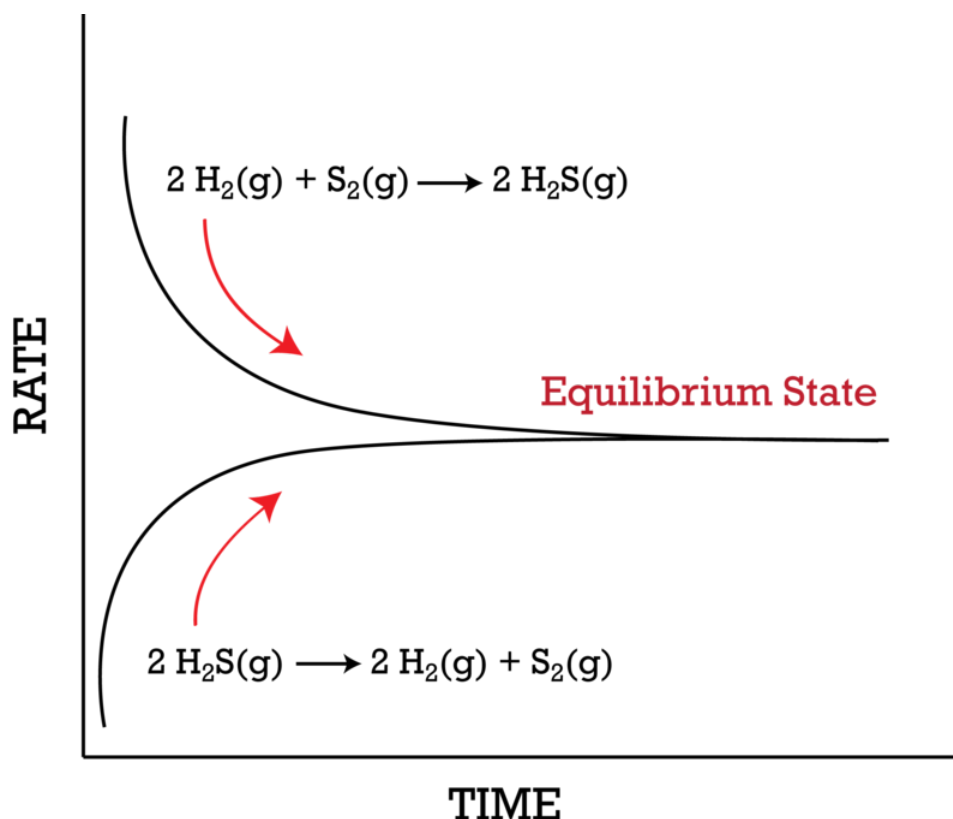

Chemists use a double arrow to show that a reaction is in equilibrium. For the reaction above, the chemical equation would be:

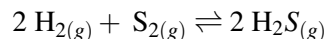

This indicates that both directions of the reaction are occurring. Note that a double-headed arrow (\leftrightarrow) should not be used here because this has a different chemical meaning.

Dynamic Equilibrium

One characteristic of a system at equilibrium is that the macroscopic properties do not change over time. **Macroscopic properties** are those that describe the system as a whole. These can be observed and measured without needing to investigate the system in terms of individual molecules.

One example of a macroscopic property is temperature. Although temperature can be explained on a microscopic level by the speed at which particles are moving around, individual molecules do not have a “temperature.” A glass of water with a constant temperature contains molecules with a large range of different speeds, and the speed of any individual molecule is constantly changing as it collides with other molecules and gains or loses kinetic energy. However, if you average out the properties of all these molecules (7.91×10^{24}) for an 8 oz glass of water), the overall temperature appears constant, despite continuous changes on the microscopic level.

Concentration is another example of a macroscopic property. It describes the total amount of a substance, but it does not make any statement about what is occurring on a molecular level. When a reaction is at equilibrium, the concentration of each component is constant over time. As we saw before, both the forward and reverse reactions are still taking place, but since they are moving at the same rate, there is no change for the system as a whole. The term **dynamic equilibrium** refers to a state where no *net* change is taking place, despite the fact that both reactions are still occurring. Individual molecules are still being formed and broken down, but the system as a whole is not changing over time.

Other Conditions Necessary for Equilibrium

In order for a reaction to reach an equilibrium state, it needs to take place in a closed system. Consider the following reaction:

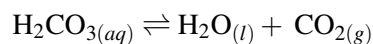

This equilibrium is established in a closed can of soda because neither the reactants nor the products can leave the system. However, when you open the soda, one of the products (CO_2) is free to escape into the atmosphere. If a molecule of CO_2 escapes, it is no longer available to collide with the water molecules left behind, so it can no longer participate in the reverse reaction. Therefore, the forward reaction will eventually go to completion until there is no more H_2CO_3 available. Note that since H_2CO_3 is an acid, an open soda will become less acidic over time. Acidity is an important component of taste, so flat soda really does taste different for reasons other than texture.

Another requirement for a system to stay in equilibrium is that the temperature and pressure stay constant. As we learned in the previous chapter, temperature and pressure both have an effect on the rate of a reaction. However, the effect might be greater for the forward reaction than the reverse reaction, or vice versa. For example, in the reaction above, adding heat will favor the forward reaction more than the reverse, resulting in the production of more CO_2 . This is true even if the can remains closed. Eventually, a new equilibrium will be established at the new temperature, but while the temperature is changing, the system is no longer in equilibrium.

Lesson Summary

- Irreversible reactions will continue to form products until the reactants are fully consumed.
- Reversible reactions will react until a state of equilibrium is reached.
- A reaction is at equilibrium when there is no net change to the system over time.
- Dynamic equilibrium refers to an equilibrium where forward and reverse reactions are still occurring, but they are proceeding at the same rate, so there is no net change.

Review Questions

1. What does the term dynamic equilibrium mean?
2. List all of the conditions for a dynamic equilibrium.
3. Of the following conditions, which is not required for a dynamic equilibrium?
 - a. rate of the forward reaction equals the rate of the reverse reaction.
 - b. reaction occurs in an open system
 - c. reaction occurs at a constant temperature

- d. reaction occurs in a closed system
4. Which of the following systems, at room temperature and pressure, can be described as a dynamic equilibrium?
- an open flask containing air, water and water vapor
 - a glass of water containing ice cube cubes and cold water
 - a closed bottle of soda pop
 - an open flask containing solid naphthalene
5. Is each of the following in a state of equilibrium? Explain.
- Ice cubes are melting in a glass of water with a lid on it
 - Crystals of potassium dichromate were dissolved in water, and now the water is a uniform orange color with a small amount of crystal left in the closed container.
 - An apple that is left on the counter for a few days, it dries out and turns brown.
6. If the following table (**Table 19.1**) of concentration vs. time was provided to you for the ionization of acetic acid, how would you know when equilibrium was reached?

TABLE 19.1: Data Table For Problem 6

Time (min)	[HC ₂ H ₃ O ₂] mol/L
0	0.100
0.5	0.099
1.0	0.098
1.5	0.097
2.0	0.096
2.5	0.095
3.0	0.095
3.5	0.095
4.0	0.095
4.5	0.095
5.0	0.095

19.2 Equilibrium Constant

Lesson Objectives

The student will:

- write equilibrium constant expressions.
- use equilibrium constant expressions to solve for unknown concentrations.
- use known concentrations to solve for the equilibrium constants.
- explain what the value of K means in terms of relative concentrations of reactants and products.

Vocabulary

- equilibrium constant (K)

Introduction

You were introduced to two types of equations in the chapter on “Chemical Kinetics.” One consisted of reactions where the overall equation and the reaction mechanism were exactly the same. In those reactions, the reaction occurred with a single collision. The other type of reactions involved a reaction mechanism consisting two or more steps, and the overall equation was the sum of the equations for the reaction mechanism.

For those reactions that consist of a single collision, the reaction rate can be expressed by inserting the concentrations of the reactants into the expression:

$$\text{Reaction Rate} = k_F[A][B], \text{ where } A \text{ and } B \text{ are the reactants}$$

For the reactions that have reaction mechanisms of two or more steps, the relationship between the concentration of a particular reactant and the reaction rate is more complex. The rate of these reactions can still be expressed in a similar manner, but which reactants go into the expression and how they are involved must be determined experimentally.

In the previous section, you were introduced to the possibility of a reverse reaction. For the reaction between A and B yielding C and D , we have not only the forward reaction:

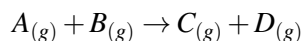

but we also could have a reverse reaction:

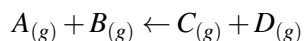

If this reverse reaction occurs, it would be the same simple collision that was involved in the forward reaction. Therefore, the reaction rate of the reverse reaction could be expressed as:

Reaction Rate = $k_R[C][D]$, where the products C and D have become reactants

When this reaction reaches equilibrium and the two rates become constant and equal,

$$\begin{aligned} \text{Rate}_{\text{forward}} &= \text{Rate}_{\text{reverse}} \text{ and } k_F[A][B] = k_R[C][D] \\ k_F[A][B] &= k_R[C][D] \end{aligned}$$

Algebraic manipulation of the expression yields

$$\frac{k_F}{k_R} = \frac{[C][D]}{[A][B]}$$

Since both k_F and k_R are constants, then dividing one constant by another yields another constant. The new constant is called the **equilibrium constant** and is symbolized by the capital letter K .

$$K = \frac{[C][D]}{[A][B]}$$

The Equilibrium Constant

The equilibrium constant (K or K_{eq}) represents a mathematical relationship that shows how the concentration of one reaction component is related to the concentration of other reactants and products at equilibrium. Sometimes you may see the equilibrium constant written with other subscripts, such as K_a , K_b , K_w , or K_{sp} . These indicate that the constant describes a specific type of reaction, but they operate exactly the same as any other equilibrium constant.

The equilibrium constant for any reaction can be written by following a few simple rules. We have already learned how to write the expression for a simple generic reaction:

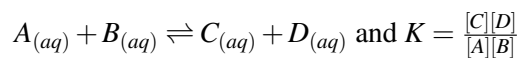

But suppose the reaction was $2 A_{(aq)} + B_{(aq)} \rightleftharpoons C_{(aq)} + D_{(aq)}$. Writing the equation with a coefficient of 2 in front of the A is exactly the same as writing the equation this way:

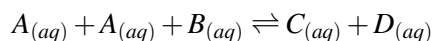

In this second form of the equation, we have just written A twice instead of using a coefficient to show that two molecules are involved in the reaction. If we write the equilibrium constant expression from this last equation, it would look like:

$$K = \frac{[C][D]}{[A][A][B]}$$

With our knowledge of algebra, we know that writing $[A] \times [A]$ is the same as writing $[A]^2$. Therefore, the equilibrium constant would become

$$K = \frac{[C][D]}{[A]^2[B]}$$

As you can see, the coefficient in the equation has become an exponent in the equilibrium constant. The general rule for writing an equilibrium constant expression is to write the coefficient of each species in the reaction as an exponent in the equilibrium constant expression. So, for the reaction:

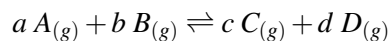

where the lower case a , b , c , and d are coefficients, the equilibrium constant expression would be:

$$K = \frac{[C]^c[D]^d}{[A]^a[B]^b}$$

Here is an example equation and its equilibrium constant expression.

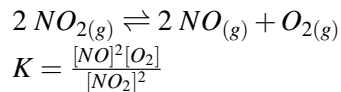

There are cases where the concentration of a particular reactant or product does not change when it is used or produced. The concentration of a substance is the moles of the substance divided by the volume (in liters) occupied. In the case of a substance dissolved in a beaker of water, its volume is the same as the volume of the solution. If half of the substance is used up in a reaction, the remaining half is still dissolved in the same volume of water. Therefore, its concentration will be cut in half. In the case of a solid reactant, however, it is not dissolved in the water, so its volume is the volume of the solid itself. If half of the solid is used in a reaction, the amount of moles remaining has been cut in half, but the volume of the solid has also been cut in half. Its concentration, then, stays exactly the same. This is also true of any solid or liquid that is not dissolved in a solution.

If the state of a reactant or product is indicated by (aq) or (g) , its concentration can change, but if its state is indicated by (s) or (l) , its concentration cannot change. Since the concentrations of these substances cannot change, their numerical value in the equilibrium constant expression will be a constant. To simplify the equilibrium expression, these constants can be algebraically combined with K to produce a new constant, K' . To avoid confusion, chemists have decided to always omit solids and liquids from the equilibrium expression, and it is assumed that the constant concentration values for those reaction components are already combined into the equilibrium constant. Here are some examples.

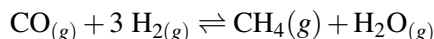

$$K = \frac{[\text{CH}_4][\text{H}_2\text{O}]}{[\text{CO}][\text{H}_2]^3}$$

Note the coefficient of 3 becomes an exponent.

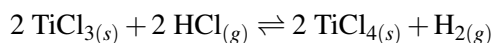

$$K = \frac{[\text{H}_2]}{[\text{HCl}]^2}$$

Note the two solids are omitted and the coefficients become exponents.

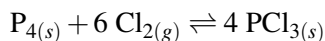

$$K = \frac{1}{[\text{Cl}_2]^6}$$

Note the solids are omitted and the coefficient becomes an exponent.

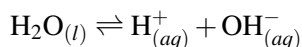

$$K = [\text{H}^+][\text{OH}^-]$$

Note the liquid water is omitted and the denominator is omitted when it is 1.

This video shows an example of how to plug values into an equilibrium constant expression (9c): <http://www.youtube.com/watch?v=lZbrwtY5K3k> (2:48).

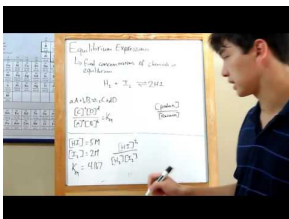
**MEDIA**

Click image to the left for more content.

Mathematics with Equilibrium Expressions

The mathematics involved with equilibrium expressions can range from the straightforward to the complex. For example, look at the sample question below.

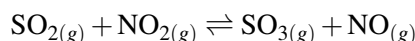
Example:

Determine the value of K when the equilibrium concentrations are: $[SO_2] = 1.20 \text{ M}$; $[NO_2] = 0.60 \text{ M}$; $[NO] = 1.6 \text{ M}$; $[SO_3] = 2.2 \text{ M}$. Are the reactants or products favored? Explain your answer.

Solution:

Step 1: Write the equilibrium constant expression:

$$K = \frac{[SO_3][NO]}{[SO_2][NO_2]}$$

Step 2: Substitute in given values and solve:

$$K = \frac{(2.2)(1.6)}{(1.20)(0.60)} = 4.9$$

The equilibrium constant value is the ratio of the concentrations of the products over the reactants. Therefore, a value of 4.9 for the equilibrium constant indicates that there are more products (numerator) than there are reactants (denominator). If the equilibrium constant is 1 or nearly 1, it indicates that the molarities of the reactants and products are about the same. If the equilibrium constant value is a large number, it indicates that the great majority of the material is in the form of products at equilibrium, and we say “the products are strongly favored.” If the equilibrium constant is small, it indicates that the reactants are strongly favored.

Example:

At a given temperature, the reaction $CO(g) + H_2O(g) \rightleftharpoons H_2(g) + CO_2(g)$ produces the following concentrations at equilibrium: $[CO] = 0.200 \text{ M}$; $[H_2O] = 0.500 \text{ M}$; $[H_2] = 0.320 \text{ M}$; $[CO_2] = 0.420 \text{ M}$. Find K .

Solution:

Step 1: Write the equilibrium expression:

$$K = \frac{[H_2][CO_2]}{[CO][H_2O]}$$

Step 2: Substitute the given values and solve:

$$K = \frac{(0.320)(0.420)}{(0.200)(0.500)} = 1.34$$

Example:

For the same reaction and the same temperature as the previous example, the concentrations of the substances at equilibrium become: $[\text{CO}] = ?$; $[\text{H}_2\text{O}] = 0.100 \text{ M}$; $[\text{H}_2] = 0.100 \text{ M}$; $[\text{CO}_2] = 0.100 \text{ M}$. What is the concentration of CO?

Solution:

Since it is the same reaction at the same temperature, the K value will be the same, 1.34.

Step 1: Rearrange the equilibrium constant expression to solve for the unknown:

$$K = \frac{[\text{H}_2][\text{CO}_2]}{[\text{CO}][\text{H}_2\text{O}]} \text{ so } [\text{CO}] = \frac{[\text{H}_2][\text{CO}_2]}{K [\text{H}_2\text{O}]}$$

Step 2: Substitute and solve:

$$[\text{CO}] = \frac{(0.100)(0.100)}{(1.34)(0.100)} = 0.0746 \text{ M}$$

For an introduction to chemical equilibrium (9b) see: <http://www.youtube.com/watch?v=vCNENmgNJYg> (10:29), http://www.youtube.com/watch?v=KIN112Q_aJY (9:03).

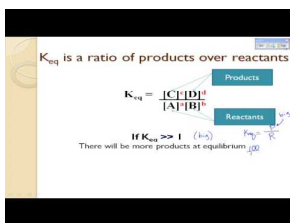
**MEDIA**

Click image to the left for more content.

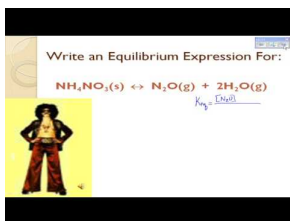
**MEDIA**

Click image to the left for more content.

Lesson Summary

- The equilibrium constant, K , is a mathematical relationship that shows how the concentrations of the products vary with the concentration of the reactants.
- If the value of K is greater than 1, the products in the reaction are favored; if the value of K is less than 1, the reactants in the reaction are favored; if K is equal to 1, neither reactants nor products are favored.

Review Questions

- Why are solids and liquids not included in the equilibrium constant expression?
- What does the value of K mean in terms of the amount of reactants and products?
- What is the correct equilibrium constant expression for the following reaction: $2 \text{SO}_2(\text{g}) + \text{O}_2(\text{g}) \rightleftharpoons 2 \text{SO}_3(\text{g})$?

a. $K = \frac{[\text{SO}_2]^2[\text{O}_2]}{[\text{SO}_3]^2}$

$$\begin{aligned} \text{b. } K &= \frac{[\text{SO}_3]^2}{[\text{SO}_2]^2[\text{O}_2]} \\ \text{c. } K &= \frac{[\text{SO}_3]}{2[\text{SO}_2][\text{O}_2]} \\ \text{d. } K &= \frac{[\text{SO}_3]}{2[\text{SO}_2][\text{O}_2]} \end{aligned}$$

4. What is the correct equilibrium constant expression for the following reaction: $\text{Cu}(\text{OH})_{2(s)} \rightleftharpoons \text{Cu}^{2+}_{(aq)} + 2 \text{OH}^{-}_{(aq)}$?
- $K = \frac{[\text{Cu}^{2+}][\text{OH}^{-}]^2}{[\text{Cu}(\text{OH})_2]}$
 - $K = \frac{[\text{Cu}(\text{OH})_2]}{[\text{Cu}^{2+}][\text{OH}^{-}]^2}$
 - $K = \frac{1}{[\text{Cu}^{2+}][\text{OH}^{-}]^2}$
 - $K = [\text{Cu}^{2+}][\text{OH}^{-}]^2$
5. Consider the following equilibrium system: $2 \text{NO}_{(g)} + \text{Cl}_{2(g)} \rightleftharpoons 2 \text{NOCl}_{(g)}$. At a certain temperature, the equilibrium concentrations are as follows: $[\text{NO}] = 0.184 \text{ mol/L}$, $[\text{Cl}_2] = 0.165 \text{ mol/L}$, and $[\text{NOCl}] = 0.060 \text{ mol/L}$. What is the equilibrium constant for this reaction?
- 0.506
 - 0.648
 - 1.55
 - 1.97
6. For the reaction $2 \text{MgCl}_{2(s)} + \text{O}_{2(g)} \rightleftharpoons 2 \text{MgO}_{(s)} + 2 \text{Cl}_{2(g)}$, the equilibrium constant was found to be 3.86 at a certain temperature. If 0.560 mol $\text{O}_{2(g)}$ is placed in a 1.00 L container, what is the concentration of $\text{Cl}_{2(g)}$ at equilibrium?
- 1.47 mol/L
 - 2.16 mol/L
 - 2.88 mol/L
 - not enough information is available
7. Write the equilibrium constant expressions for each of the following equations:
- $\text{CH}_3\text{NH}_{2(aq)} + \text{H}_2\text{O}_{(l)} \rightleftharpoons \text{CH}_3\text{NH}_3^+_{(aq)} + \text{OH}^-_{(aq)}$
 - $2 \text{CaSO}_{4(s)} \rightleftharpoons 2 \text{CaO}_{(s)} + 2 \text{SO}_{2(g)} + \text{O}_{2(g)}$
 - $2 \text{Fe}^{3+}_{(aq)} + 3 \text{S}^{2-}_{(aq)} \rightleftharpoons \text{Fe}_2\text{S}_3(s)$
 - $\text{Hg}_{(l)} + \text{H}_2\text{S}_{(g)} \rightleftharpoons \text{HgS}_{(s)} + \text{H}_2(g)$

19.3 The Effects of Applying Stress to Reactions at Equilibrium

Lesson Objectives

The student will:

- state Le Châtelier's Principle.
- demonstrate on specified chemical reactions how Le Châtelier's Principle is applied to equilibrium systems.
- describe the effect of concentration on an equilibrium system.
- demonstrate with specific equations how Le Châtelier's Principle explains the effect of concentration.
- describe the effect of pressure as a stress on the equilibrium position.
- describe the pressure effect in Le Châtelier's Principle.
- describe the effect of temperature as a stress on an equilibrium system.
- explain how Le Châtelier's principle explains the effect of temperature.
- understand how a catalyst works in equilibrium reactions.
- explain the effect of a catalyst in equilibrium reactions.

Vocabulary

- Le Châtelier's Principle

Introduction

When a reaction has reached equilibrium with a given set of conditions, if the conditions are not changed, the reaction will remain at equilibrium forever. The forward and reverse reactions continue at the same equal and opposite rates, and the macroscopic properties remain constant.

It is possible, however, to alter the reaction conditions. For example, you could increase the concentration of one of the products, or decrease the concentration of one of the reactants, or change the temperature. When a change of this type is made in a reaction at equilibrium, the reaction is no longer in equilibrium. When you alter something in a reaction at equilibrium, chemists say that you put *stress* on the equilibrium. When this occurs, the reaction will no longer be in equilibrium, so the reaction itself will begin changing the concentrations of reactants and products 'until the reaction comes to a new position of equilibrium. How a reaction will change when a stress is applied can be explained and predicted and is the topic of this lesson.

Le Châtelier's Principle

In the late 1800s, a chemist by the name of Henry-Louis Le Châtelier was studying stresses that were applied to chemical equilibria. He formulated a principle, **Le Châtelier's Principle**, which states that when a stress is applied

to a system at equilibrium, the equilibrium will shift in a direction to partially counteract the stress and once again reach equilibrium. For instance, if a stress is applied by increasing the concentration of a reactant, the equilibrium position will shift toward the right and remove that stress by using up some of the reactants. The reverse is also true. If a stress is applied by lowering a reactant concentration, the equilibrium position will shift toward the left, this time producing more reactants to partially counteracting that stress. The same reasoning can be applied when some of the products is increased or decreased.

Le Châtelier's principle does not provide an explanation of what happens on the molecular level to cause the equilibrium shift. Instead, it is simply a quick way to determine which way the reaction will run in response to a stress applied to the system at equilibrium.

Effect of Concentration Changes

Let's use Le Châtelier's principle to explain the effect of concentration changes on an equilibrium system. Consider the generic equation:

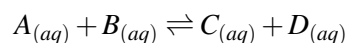

At equilibrium, the forward and reverse rates are equal. The concentrations of all reactants and products remain constant, which keeps the rates constant. Suppose we add some additional A , thus raising the concentration of A without changing anything else in the system. Since the concentration of A is larger than it was before, the forward reaction rate will suddenly be higher. The forward rate will now exceed the reverse rate. Now there is a net movement of material from the reactants to the products. As the reaction uses up reactants, the forward rate that was too high slowly decreases while the reverse rate that was too low slowly increases. The two rates are moving toward each other and will eventually become equal again. They do not return to their previous rates, but they do become equal at some other value. As a result, the system returns to equilibrium.

Le Châtelier's principle says that when you apply a stress (adding A), the equilibrium system will shift to partially counteract the applied stress. In this case, the reaction shifts toward the products so that A and B are used up and C and D are produced. This reduction of the concentration of A is counteracting the stress you applied (adding A).

Suppose instead that you removed some A instead of adding some. In that case, the concentration of A would decrease, and the forward rate would slow down. Once again, the two rates are no longer equal. At the instant you remove A , the forward rate decreases, but the reverse rate remains exactly what it was. The reverse rate is now greater than the forward rate, and the equilibrium will shift toward the reactants. As the reaction runs backward, the concentrations of C and D decrease, slowing the reverse rate, and the concentrations of A and B increase, raising the forward rate. The rates are again moving toward each other, and the system will again reach equilibrium. The shift of material from products to reactants increases the concentration of A , thus counteracting the stress you applied. Le Châtelier's principle again correctly predicts the equilibrium shift.

The effect of concentration on the equilibrium system according to Le Châtelier is as follows: increasing the concentration of a reactant causes the equilibrium to shift to the right, using up reactants and producing more products. Increasing the concentration of a product causes the equilibrium to shift to the left, using up products and producing more reactants. The exact opposite is true when either a reactant or product is removed.

Example:

For the reaction $\text{SiCl}_{4(g)} + \text{O}_{2(g)} \rightleftharpoons \text{SiO}_{2(s)} + 2 \text{Cl}_{2(g)}$, what would be the effect on the equilibrium system if:

1. $[\text{SiCl}_4]$ increases
2. $[\text{O}_2]$ increases
3. $[\text{Cl}_2]$ increases

Solution:

1. The equilibrium would shift to the right. $[\text{Cl}_2]$ would increase, more SiO_2 would be produced (but that does not increase its concentration since it's a solid), and $[\text{O}_2]$ would decrease.
2. The equilibrium would shift to the right. $[\text{SiCl}_4]$ would decrease, more SiO_2 would be produced (but again no change in concentration), and $[\text{Cl}_2]$ would increase.
3. The equilibrium would shift left. $[\text{SiCl}_4]$ and $[\text{O}_2]$ would increase, and SiO_2 would be used up but not change its concentration.

Let's take a moment to consider what happens to the concentration of a reactant or product that is changed. In our theoretical reaction, if you add A , the concentration of A will increase. The equilibrium shifts toward the products, and A is used. Where does the concentration of A end up, higher or lower than the original concentration? The concentration of A increases when you add more A , but it decreases as the equilibrium shifts. A new equilibrium, however, will be reached before the concentration of A gets back down to its original concentration. This is why Le Châtelier's principle says the equilibrium will shift to *partially* counteract the applied stress. The equilibrium shift will move toward returning the concentration to where it was before you applied the stress, but the concentration never quite gets back to the original value before a new equilibrium is established.

Example:

For the reaction $\text{PCl}_3(g) + \text{Cl}_2(g) \rightleftharpoons \text{PCl}_5(g)$, which way will the equilibrium shift if:

1. $[\text{PCl}_3]$ decreases
2. $[\text{Cl}_2]$ decreases
3. $[\text{PCl}_5]$ decreases

Solution:

1. left
2. left
3. right

Example:

Here's a reaction at equilibrium. Note the phases of each reactant and product.

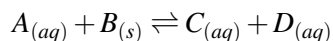

1. Which way will the equilibrium shift if you add some A to the system without changing anything else?
2. After A has been added and a new equilibrium is reached, how will the new concentration of D compare to the original concentration of D ?
3. After A has been added and a new equilibrium has been established, how will the new concentration of A compare to the original concentration of A ?
4. After A has been added and a new equilibrium has been established, how will the new concentration of B compare to the original concentration of B ?
5. Which way will the equilibrium shift if you add some C to the system without changing anything else?
6. After C has been added and a new equilibrium has been established, how will the new concentration of D compare its original concentration?
7. After C has been added and a new equilibrium has been established, how will the new concentration of A compare its original concentration?
8. Which way will the equilibrium shift if you add some B to the system without changing anything else?

Solution:

1. The equilibrium will shift toward the products.
2. The new concentration of D will be higher than the original.
3. The new concentration of A will be higher than the original, but lower than the concentration right after A was added.
4. Since B is a solid, its concentration will be the same as the original. There will be less of it since some was used in the equilibrium shift, but the concentration will be the same.
5. The equilibrium will shift toward the reactants.
6. The new concentration of D will be lower than the original.
7. The new concentration of A will be higher than the original.
8. Since B is a solid, adding B will not change its concentration and therefore has no effect on the equilibrium. It is possible that adding some B will increase the surface area of B and therefore increase the forward reaction rate, but it will also increase the reverse reaction rate by approximately the same amount, hence no shift in equilibrium.

The Haber Process and Concentration Change Effects

The reaction between nitrogen gas and hydrogen gas can produce ammonia, NH_3 . However, under normal conditions, this reaction does not produce very much ammonia. Early in the 20th century, the commercial use of this reaction was too expensive because of the low yield.

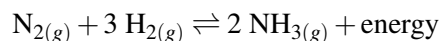

A German chemist named Fritz Haber applied Le Châtelier's principle to help solve this problem. Decreasing the concentration of ammonia by immediately removing it from the reaction container causes the equilibrium to shift to the right, so the reaction can continue to produce more product. Haber used Le Châtelier's principle to solve this problem in other ways as well. These will be discussed in the following sections.

Summary

- Increasing the concentration of a reactant causes the equilibrium to shift to the right, producing more products.
- Increasing the concentration of a product causes the equilibrium to shift to the left, producing more reactants.
- Decreasing the concentration of a reactant causes the equilibrium to shift to the left, using up some products.
- Decreasing the concentration of a product causes the equilibrium to shift to the right, using up some reactants.

Questions

1. What is the effect on the equilibrium position if the [reactants] is increased?
2. What is the effect on the equilibrium position if the [reactants] is decreased?
3. Which of the following will cause a shift in the equilibrium position of the equation: $2 \text{C}_8\text{H}_{18(l)} + 25 \text{O}_{2(g)} \rightleftharpoons 18 \text{H}_2\text{O}_{(l)} + 16 \text{CO}_{2(g)}$? i. add C_8H_{18} ii. add O_2 iii. remove CO_2 iv. remove H_2O
 - a. i and ii only
 - b. ii and iii only
 - c. ii and iv only
 - d. i, ii, iii, and iv
4. Which of the following will cause a shift in the equilibrium position of the equation: $\text{CaCO}_{3(s)} \rightleftharpoons \text{CaO}_{(s)} + \text{CO}_{2(g)}$? i. add CaCO_3 ii. add CO_2 iii. remove CaO iv. remove CO_2
 - a. ii only
 - b. i and iii only
 - c. ii and iv only

- d. i, ii, iii, and iv only
5. For the reaction: $\text{N}_2\text{O}_{5(s)} \rightleftharpoons \text{NO}_{2(g)} + \text{O}_{2(g)}$, what would be the effect on the equilibrium if:
- N_2O_5 is added?
 - NO_2 is removed?
 - NO_2 is added?
 - O_2 is added?
6. Answer the following questions when $[\text{CO}]$ is increased in the following system at equilibrium: $\text{Fe}_2\text{O}_{3(s)} + 3 \text{CO}_{(g)} \rightleftharpoons 2 \text{Fe}_{(s)} + 3 \text{CO}_{2(g)}$.
- Write the equilibrium constant expression.
 - Which direction will this equilibrium shift?
 - What effect will this stress have on $[\text{CO}_2]$?
7. For the reaction $\text{C}_{(s)} + \text{H}_2\text{O}_{(g)} \rightleftharpoons \text{CO}_{(g)} + \text{H}_{2(g)}$, what would be the effect on the equilibrium system if:
- $[\text{H}_2\text{O}]$ increases?
 - mass of C decreases?
 - $[\text{CO}]$ increases?
 - $[\text{H}_2]$ decreases?

Effect of Changes of Pressure

A second type of stress studied by Le Châtelier was the effect of changing the pressure of a system at equilibrium. Reactants and products that are in solid, liquid, or aqueous states are *not* compressible, so raising or lowering the pressure on a system that contains no gases will have no effect on the equilibrium. If, however, the reaction at equilibrium contains at least one gas in either the reactants or products, altering the pressure will alter the equilibrium.

To get a better understanding of how pressure changes are affecting gaseous reaction components, it may help to consider the relationship between pressure and concentration for a gas at a given temperature. Recall that for an ideal gas, $PV = nRT$, where R is a constant. Since temperature is also held constant in this case, R and T can be combined to form a new constant, which we'll call x . Dividing both sides by volume now gives us $P = x \cdot (n/V)$. Remember that n is in moles and V is in liters; moles/liters = molarity. Thus, the pressure of a gas at a constant temperature is directly proportional to its concentration. When we are talking about the partial pressure of a gas, keep in mind that we are essentially talking about its concentration. This will help you to grasp some of the potentially confusing effects pressure can have on the equilibrium position.

Suppose we have the following reaction at equilibrium.

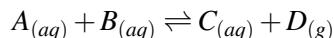

Since the reaction has at least one gaseous substance involved in the reaction, its equilibrium will be affected by a change in the partial pressure of that gas. In order for this reaction to reach equilibrium, it would have to be in a closed reaction vessel so that the gaseous product do not escape. The gas must stay in contact with the solution for the reverse reaction to occur.

There are at least three ways to increase the pressure in the area above the liquid in the cylinder: 1) add some other gas not involved in the reaction, 2) add some gaseous D into the space above the liquid, and 3) push the piston down so the space above the liquid in the cylinder is decreased (see figure below).

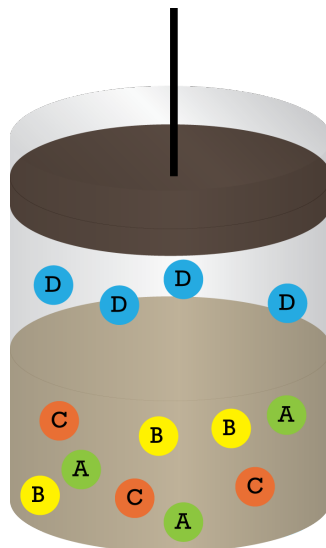

1. Increasing the pressure in the cylinder by adding a gas not involved in the reaction will increase the total gas pressure in the cylinder, but it will not affect the partial pressure of D , so there will be no effect on the equilibrium of this reaction. This concept might be easier to understand if we think about it in terms of concentration rather than pressure. If we have the same amount of gas in the same amount of space, the concentration of the gas and thus its partial pressure will not change. The fact that some other gas was added does not change either of these key values. This is why only changes to the partial pressure of the reaction component, not the total pressure, are able to affect the equilibrium position.
2. Adding some gaseous D to the cylinder is the same as adding a reactant or product, which has already been discussed earlier.
3. Lowering the piston in the cylinder pushes the D molecules into a smaller space, increasing both the partial pressure of gaseous D and its concentration in the space above the liquid. Since the concentration of D is increased, the reverse reaction rate will increase and the equilibrium will shift toward the reactants.

The reverse of this is also true. If you expand the volume of the cylinder by raising the piston, the partial pressure and concentration of D will decrease. When the concentration of D decreases, the reverse rate slows and the forward reaction rate will drive the equilibrium toward the products. This equilibrium shift increases the concentration and partial pressure of D , once again counteracting the stress you applied.

Increasing Pressure Shifts Equilibrium Toward Fewer Moles of Gas

When you have a reaction at equilibrium with gaseous substances on both sides of the equation, the explanation for what happens is more complicated. Consider the following equation:

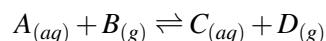

In this case, there are gaseous reactants and gaseous products. It should be easy to see that if we reduce the volume above this reaction to half of its previous volume, the partial pressures and the concentrations of these two gases will be doubled. Therefore, both reaction rates will increase because concentrations on each side have been increased. If we assume that we are still dealing with single collision reactions (so that the forward and reverse rates can be expressed as $R_F = k_F[A][B]$ and $R_R = k_R[C][D]$), then we can see that doubling the concentration of B doubles the forward rate and doubling the concentration of D doubles the reverse rate. Both rates will increase, but since they increase by the same factor, the equilibrium will *not* shift.

Now consider the reaction below:

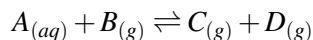

This time, we see that there is one gas in the reactants and two gases in the products. If we once again reduce the volume of the gases by half, the partial pressures and the concentrations of the gases will double. Therefore, we double the forward reaction rate because we doubled the concentration of B . In terms of the products, we are doubling the concentrations of C and D . The new reverse rate is:

$$\text{Reverse Rate}_{NEW} = k(2[C])(2[D]) = 4k[C][D]$$

Therefore, the new reverse rate will be four times the original reverse rate. If we double the forward reaction rate and quadruple the reverse rate, the equilibrium shift will be toward the reactants.

When you increase the pressure (by reducing volume) on a reaction at equilibrium, the equilibrium shift will be toward the side that has fewer moles of gas. A decrease in pressure due to a volume expansion will shift the equilibrium to the side with more moles of gas. Once again, you should note that Le Châtelier's principle predicts this result. If the equilibrium shift is converting 2 moles of gas to 1 moles of gas, then the shift is reducing the number of moles of gas and the total pressure will decrease. You applied a stress by increasing the pressure, and the equilibrium shift tends to counteract that stress by reducing pressure.

Example:

For the reaction $2 \text{SO}_{2(g)} + \text{O}_{2(g)} \rightleftharpoons 2 \text{SO}_{3(g)}$, what would be the effect on the equilibrium position when the pressure is increased by reducing the volume?

Solution:

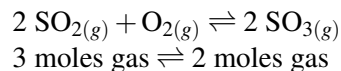

If the pressure increases, the reaction would shift to the side with the least number of moles of gas. Since there are 3 moles of gaseous reactants and 2 moles of gaseous products, the equilibrium would shift right, producing more products.

Example:

For the reaction $4 \text{NH}_{3(g)} + 5 \text{O}_{2(g)} \rightleftharpoons 4 \text{NO}_{(g)} + 6 \text{H}_2\text{O}_{(g)}$, what would be the effect on the equilibrium system if the pressure decreases?

Solution:

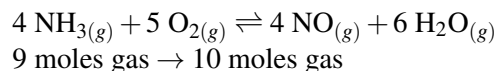

If the pressure decreases, the reaction would shift to the side with the greater number of moles of gas. Since there are nine moles of gaseous reactants and ten moles of gaseous products, the equilibrium would shift right, producing more products.

Example:

For the reaction $\text{PCl}_{5(g)} \rightleftharpoons \text{Cl}_{2(g)} + \text{PCl}_{3(g)}$, what would be the effect on the equilibrium system when (1.) the volume increases, and (2.) the volume decreases

Solution:

1. When the volume is increased, pressure decreases, so the equilibrium will shift toward the side with more moles of gas. Therefore, $[\text{PCl}_5]$ will decrease, and $[\text{Cl}_2]$ and $[\text{PCl}_3]$ will increase.
2. When the volume is decreased, pressure increases, so the equilibrium will shift toward the side with fewer moles of gas. Therefore, $[\text{PCl}_5]$ will increase, and $[\text{Cl}_2]$ and $[\text{PCl}_3]$ will decrease.

The Haber Process and the Effect of Pressure Change

Earlier, we discussed the reaction that produces ammonia, NH_3 :

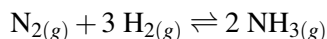

We also stated that the German chemist Fritz Haber used Le Châtelier's principle to develop a method that produces more product. Previously, we saw that when ammonia is immediately removed from the reaction container, thus decreasing the concentration, the equilibrium shifts to make up for the stress and produces more ammonia.

Now we can add another improvement: Since there are 4 moles of gas molecules in the reactants and 2 moles of gas molecules in the product, increasing the pressure (by decreasing the volume) will shift the equilibrium to the right, producing more ammonia. Later, we will discuss one more factor to complete our discussion of the Haber process.

Summary

- A decrease in volume will cause an increase in pressure, shifting the equilibrium to the side with fewer moles of gas.
- An increase in volume will cause a decrease in pressure, shifting the equilibrium to the side with more moles of gas.

Questions

1. What is the effect on the equilibrium position if the pressure is increased?
2. What is the effect on the equilibrium position if the pressure is decreased?
3. Use Le Châtelier's Principle to predict what will happen to the following reaction at equilibrium if the pressure is increased: $2 \text{NH}_{3(g)} \rightleftharpoons \text{N}_{2(g)} + 3 \text{H}_{2(g)}$. Mark all that apply.
 - a. equilibrium position shifts right
 - b. equilibrium position shifts left
 - c. $[\text{N}_2]$ will decrease
 - d. $[\text{NH}_3]$ will increase
4. Use Le Châtelier's principle to predict what will happen to the following reaction at equilibrium if the pressure is decreased: $2 \text{NO}_{(g)} + 2 \text{H}_{2(g)} \rightleftharpoons \text{N}_{2(g)} + 2 \text{H}_2\text{O}_{(g)}$. Mark all that apply.
 - a. equilibrium position will not shift
 - b. equilibrium position shifts left
 - c. $[\text{N}_2]$ will increase
 - d. $[\text{NO}]$ will increase
5. Use Le Châtelier's principle to predict what will happen to the following reaction at equilibrium if the volume is decreased: $2 \text{NCl}_{3(g)} \rightleftharpoons \text{N}_{2(g)} + 3 \text{Cl}_{2(g)}$. Mark all that apply.
 - a. equilibrium position shifts right
 - b. equilibrium position shifts left
 - c. $[\text{N}_2]$ will increase
 - d. $[\text{NCl}_3]$ will decrease
6. For the reaction $2 \text{N}_2\text{O}_{(g)} + \text{O}_{2(g)} \rightleftharpoons 4 \text{NO}_{(g)}$, what would be the effect on the equilibrium system if the pressure increases (or the volume decreases)?
7. For the reaction $2 \text{IBr}_{(g)} \rightleftharpoons \text{I}_{2(g)} + \text{Br}_{2(g)}$, what would be the effect on the equilibrium system if the pressure decreases (or the volume increases)?
8. For the reaction $\text{H}_{2(g)} + \text{CO}_{2(g)} \rightleftharpoons \text{H}_2\text{O}_{(g)} + \text{CO}_{(g)}$, what would be the effect on the equilibrium system if
 - a. the pressure increases?

- b. the volume decreases?
9. For the reaction $3 \text{NO}_{(g)} \rightleftharpoons \text{N}_2\text{O}_{(g)} + \text{NO}_{2(g)}$, what would be the effect on the equilibrium system if
- the pressure increases?
 - the volume decreases?

Effect of Changing Temperature

As we saw in the chapter “Chemical Kinetics,” one of the most important factors that determines reaction rate is temperature. Raising the temperature will increase the average speed of the individual particles, thus causing more frequent collisions. Additionally, this increase in energy means that more particles will have the energy necessary to overcome the activation barrier. Overall, a rise in temperature increases both the frequency of collisions and the percentage of successful collisions.

It should be clear that increasing the temperature of the reaction vessel will increase both the forward and reverse reaction rates, but will it increase both rates equally? Let’s examine the potential energy diagram of a reaction to see if we can gain any insight there. Here is the potential energy diagram for our usual theoretical reaction:

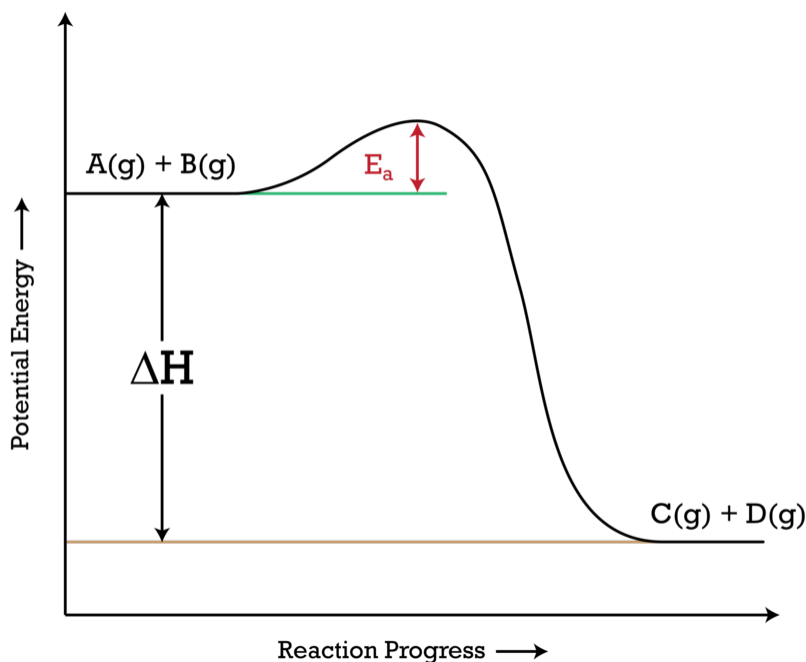
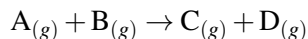

As you can see, the forward reaction has a small energy barrier while the reverse reaction has a very large energy barrier. With the reactants and products at the same temperature, the forward reaction will be much faster than the reverse reaction if the concentration of reactants is equal to the concentration of products. In the chapter “Chemical Kinetics,” we used an energy distribution curve to show the percentage of reactant particles that had sufficient activation energy to react. The figure below shows the energy distribution curves for A and B in the forward reaction and for C and D in the reverse reaction.

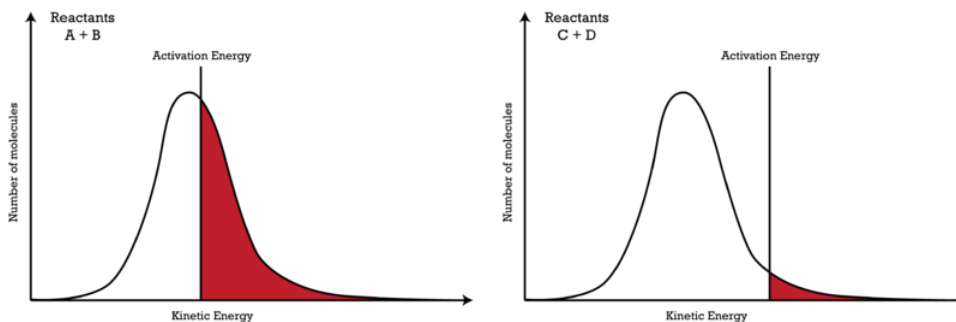

As you can see in the drawing, a much larger percentage of reactant particles than product particles have the activation energy required for a successful collision. Suppose we were to increase the temperature 10°C . The activation energy requirements remain the same for both groups of particles, but the curves will shift right to reflect the additional energy these particles possess.

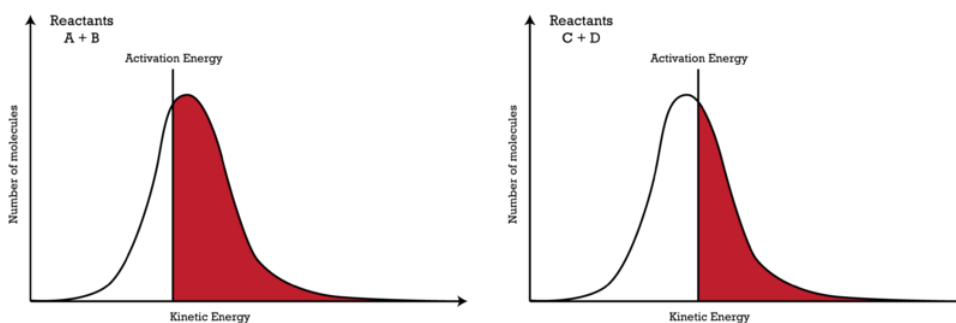

Both reaction rates will increase because a higher percentage of both reactants and products have enough energy to overcome the activation barrier. Additionally, the percentage of particles that exceed the activation energy is still higher for the reactants than the products, so the forward reaction will still be faster. However, if we look at the increase in sufficiently energetic particles, the product side has more of a change than the reactants. Thus, the reverse rate will increase more than the forward rate. The equilibrium will shift left, producing more reactants until a new equilibrium is established.

For nearly every reaction, either the forward or reverse reaction will require more activation energy than the other. The addition of energy to a reaction will increase both reaction rates, but it increases the rate of the slower reaction more. In an exothermic reaction, the products are lower in energy than the reactants, so they have a higher barrier to climb in order to reach the same transition state. Accordingly, the reverse rate will be slower for an exothermic reaction, so increasing the temperature will shift the equilibrium to the left. The reverse is true for an endothermic reaction. By looking at a potential energy diagram, you should be able to tell 1) whether the reaction is exothermic or endothermic, 2) whether the forward or reverse reaction would be slower, assuming equal concentrations of reactants and products, and 3) which direction the equilibrium would shift in response to a change in temperature.

Following the same reasoning as above, we can see that decreasing the temperature of a reaction produces an equilibrium shift in the opposite direction. Cooling an exothermic reaction results in a shift to the right, and cooling an endothermic reaction causes a shift to the left. Le Châtelier's principle correctly predicts the equilibrium shift when systems are heated or cooled. An increase in temperature is the same as adding energy to the system. Look at the following reaction:



This could also be written as:

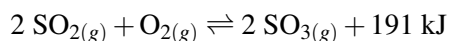

When changing the temperature of a system at equilibrium, energy can be thought of as just another product or reactant. For this reaction, 191 kJ of energy is produced for every mole of O₂ and 2 moles of SO₂ that react. Therefore, when the temperature of this system is raised, the effect will be the same as increasing any other product. As the temperature is increased, the equilibrium will shift away from the stress, resulting in more reactants and less products. As you would expect, the reverse would be true if the temperature is decreased. A summary of the effect temperature has on equilibrium systems is shown in **Table 19.2**.

TABLE 19.2: The Effect of Temperature on an Endothermic and an Exothermic Equilibrium System

	Exothermic ($-\Delta H$)	Endothermic ($+\Delta H$)
Increase Temperature	Shifts left, favors reactants	Shifts right, favors products
Decrease Temperature	Shifts right, favors products	Shifts left, favors reactants

Example:

Predict the effect on the equilibrium position if the temperature is increased in each of the following:

1. $\text{H}_{2(g)} + \text{CO}_{2(g)} \rightleftharpoons \text{CO}_{(g)} + \text{H}_2\text{O}_{(g)} \quad \Delta H = +40 \text{ kJ/mol}$
2. $2 \text{SO}_{2(g)} + \text{O}_{2(g)} \rightleftharpoons 2 \text{SO}_{3(g)} + \text{energy}$

Solution:

1. The reaction is endothermic. With an increase in temperature for an endothermic reaction, the reaction will shift right, producing more products.
2. The reaction is exothermic. With an increase in temperature for an exothermic reaction, the reaction will shift left, producing more reactants.

The Value of K Changes When Temperature Changes

The rate constant, k , for a reaction is determined for a particular temperature and is correct only at that temperature. The k value is unaffected by changes in concentration, volume, or pressure. Recall that the equilibrium constant, K , is the ratio of k_F to k_R , so if the values for the k 's don't change, neither will K . Therefore, K is also unaffected by changes in concentration, volume, or pressure. However, changing the temperature will alter the values of k_F , k_R , and K .

Temperature is the only stress, of all those studied by Le Châtelier (and others), that has the effect of increasing or decreasing the value of the equilibrium constant. The Dutch chemist Jacobus Henricus van 't Hoff derived the relationship for how equilibrium constants change with temperature shortly after Le Châtelier had reported his finding. The qualitative results of his work are presented in the following table (**Table 19.3**).

TABLE 19.3: The Effect of Temperature on an Endothermic and an Exothermic Equilibrium System

	Exothermic ($-\Delta H$)	Endothermic ($+\Delta H$)
Increase Temperature	Shifts left, favors reactants, $K \downarrow$	Shifts right, favors products, $K \uparrow$
Decrease Temperature	Shifts right, favors products, $K \uparrow$	Shifts left, favors reactants, $K \downarrow$

Example:

How does an increase in the temperature affect the value of K and the concentration of the substance boldfaced in each of the following reactions?

1. $\text{SO}_2(\text{g}) + \text{energy} \rightleftharpoons \text{S}(\text{s}) + \text{O}_2(\text{g})$
2. $\text{P}_4(\text{s}) + 10 \text{Cl}_2(\text{g}) \rightleftharpoons 4 \text{PCl}_5(\text{g}) + \text{energy}$

Solution:

1. An increase in temperature for an endothermic reaction causes a shift to the right, so the equilibrium constant K increases, and the products are favored. This means that the concentration of SO_2 will decrease.
2. An increase in temperature for an exothermic reaction causes a shift to the left, so the equilibrium constant K decreases, and the reactants are favored. This means that the concentration of PCl_5 will decrease.

The Haber Process and the Effect of Temperature Change

We have already seen that the maximum amount of ammonia produced in the Haber process can be improved by decreasing the concentration of the ammonia (by removing it from the reaction container) and increasing the pressure.

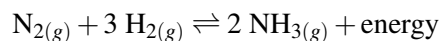

One more factor that will affect this equilibrium system is the temperature. Since the forward reaction is exothermic, lowering the temperature will once again shift the equilibrium system to the right and increase the ammonia produced. Unfortunately, this process also has a very high activation energy, so if the temperature is too low, the reaction will slow to a crawl. Thus, a balance must be struck between shifting the equilibrium to favor products and allowing products to be formed at a reasonable rate. It was found that the optimum conditions for this process (the ones that produce the most ammonia the fastest) are 550°C and 250 atm of pressure, with the ammonia being continually removed from the system.

Summary

- For an endothermic reaction, an increase in temperature shifts the equilibrium toward the products, whereas a decrease in temperature shifts the equilibrium toward the reactants.
- For an forward exothermic reaction, an increase in temperature shifts the equilibrium toward the reactant side, whereas a decrease in temperature shifts the equilibrium toward the products.
- Increasing or decreasing the temperature causes the K value to change.

Questions

1. Why does temperature affect the value of the equilibrium constant?
2. Which direction will a system at equilibrium shift for each of the following?
 - a. adding energy to a forward exothermic equilibrium system
 - b. adding energy to a reverse exothermic equilibrium system
 - c. adding energy to a forward endothermic equilibrium system
 - d. adding energy to a reverse endothermic equilibrium system
3. At a certain temperature, the equilibrium constant for the reaction $\text{Ag}^+_{(\text{aq})} + \text{Cl}^-_{(\text{aq})} \rightleftharpoons \text{AgCl}_{(\text{s})}$ ($\Delta H = -112 \text{ kJ/mol}$) is 7.43. What would the value of the equilibrium constant be if the reaction were allowed to come to equilibrium at a higher temperature?
 - a. less than 7.43
 - b. greater than 7.43
 - c. the same, 7.43
 - d. not enough information is available

4. With an increase in temperature, the equilibrium constant for a certain reaction was found to increase. Consequently, what can be said about the concentrations of the reactants and products?
 - a. They both increase.
 - b. They both decrease.
 - c. The [reactants] increase and the [products] decrease.
 - d. The [products] increase and the [reactants] decrease.
5. Predict the effect of an increase in temperature on the equilibrium position for each of the following.
 - a. $\text{H}_{2(g)} + \text{I}_{2(g)} \rightleftharpoons 2 \text{HI}_{(g)} \quad \Delta H = +51.8 \text{ kJ}$
 - b. $\text{P}_4\text{O}_{10(s)} + 6 \text{H}_2\text{O}_{(l)} \rightleftharpoons 4 \text{H}_3\text{PO}_{4(aq)} + \text{heat}$
6. How does an increase in temperature affect the value of K and the concentration of the products for each of the following?
 - a. $\text{NO}_{2(g)} + \text{NO}_{(g)} \rightleftharpoons \text{N}_2\text{O}_{(g)} + \text{O}_{2(g)} \quad \Delta H = -43 \text{ kJ}$
 - b. $4 \text{NH}_3(g) + 5 \text{O}_2(g) \rightleftharpoons 4 \text{NO}_{(g)} + 6 \text{H}_2\text{O}_{(g)} + \text{heat}$
7. Predict the effect on the equilibrium position if the temperature is increased in each of the following.
 - a. $\text{C}_2\text{H}_2(g) + \text{H}_2\text{O}_{(g)} \rightleftharpoons \text{CH}_3\text{CHO}_{(g)} \quad \Delta H = -151 \text{ kJ/mol}$
 - b. $\text{HC}_2\text{H}_3\text{O}_2(g) + \text{H}_2\text{O}_{(g)} + \text{energy} \rightleftharpoons \text{CH}_3\text{CH}_2\text{OH}_{(g)} + \text{O}_{2(g)}$

Use this information to answer questions 8 – 11. The reaction below is at equilibrium in a closed container at 25°C.

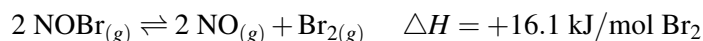

8. What will happen to the concentration of NO if the temperature is increased?
 - a. increase
 - b. decrease
 - c. remain unchanged
9. What will happen to the concentration of NOBr if the temperature is increased?
 - a. increase
 - b. decrease
 - c. remain unchanged
10. What will happen to the concentration of Br₂ if the temperature is increased?
 - a. increase
 - b. decrease
 - c. remain unchanged
11. What will happen to the value of K_e if the temperature is increased?
 - a. increase
 - b. decrease
 - c. remain unchanged

Effect of a Catalyst

We have now studied the effect of temperature, pressure, and concentration changes on a system in equilibrium. A summary of how these stresses affect the equilibrium position are found in **Table 19.4**.

TABLE 19.4: Summary of Le Châtelier Stresses and the Effect on Equilibrium

Stress	Increase	Decrease
Temperature	Endothermic, shift right	Endothermic, shift left
	Exothermic, shift left	Exothermic shift right
Pressure	Shift to side with fewer moles of gas	Shift to side with more moles of gas
Concentration	Increase [reactants], shift right	Decrease [reactants], shift left
	Increase [products], shift left	Decrease [products], shift right

Le Châtelier also studied the effect of catalysts on the equilibrium position. If the catalyst acted as a stress, would it shift the equilibrium position, and if so, how?

A Catalyst Increases Both Reaction Rates Equally

Remember that a catalyst is a substance that increases the rate of a chemical reaction but is not consumed or destroyed by the reaction. A catalyst provides an alternate pathway between reactants and products that requires less activation energy. It will not have an effect on the equilibrium position because it increases both the forward and the reverse reactions equally. Adding a catalyst to a system in equilibrium will not cause any macroscopic change. Adding a catalyst to a reaction that is not in equilibrium will cause the system to reach equilibrium faster, but the end result (the final concentrations of reactants and products) will be exactly the same with or without a catalyst.

Example:

Predict the effect on the chemical equilibrium when each of the indicated changes are made to the following reaction at equilibrium.

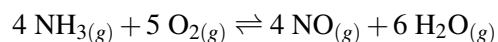

- [H₂O] is increased
- Pressure is decreased
- [NH₃] is decreased
- Catalyst is added
- Volume is decreased

Solution:

TABLE 19.5:

	4 NH _{3(g)}	5 O _{2(g)}	⇌	4 NO _(g)	6 H ₂ O _(g)
1.	↑	↑	←	↓	↑
2.	↓	↓	→	↑	↑
3.	↓	↑	←	↓	↓
4.	no effect				
5.	↑	↑	←	↓	↓

A Khan Academy electronic lecture on Le Châtelier's Principle (9a) is available at <http://www.youtube.com/watch?v=4-fEvpVNTIE> (14:43).

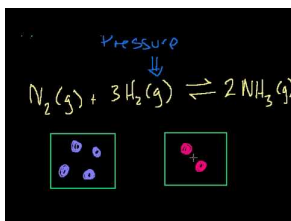

MEDIA

Click image to the left for more content.

Summary

- A catalyst affects the rate of a reaction such that both the forward and reverse reactions would be changed equally.
- A catalyst has no effect on the equilibrium position.

Questions

1. What is a catalyst? Give an example of a catalyst.
2. How does a catalyst work in an equilibrium reaction?
3. What will the effect of adding a catalyst be for the following reaction: $4 \text{NH}_3(g) + 5 \text{O}_2(g) \rightleftharpoons 4 \text{NO}(g) + 6 \text{H}_2\text{O}(g)$ ($\Delta H = -905 \text{ kJ}$)?
 - a. the [products] will increase at equilibrium
 - b. the [reactants] will increase at equilibrium
 - c. the equilibrium constant will increase for the forward reaction
 - d. there will be no effect on the equilibrium concentrations
4. The reaction between nitrogen monoxide and carbon monoxide is represented as follows: $\text{NO}(g) + \text{CO}(g) \rightleftharpoons \frac{1}{2} \text{N}_2(g) + \text{CO}_2(g)$ ($\Delta H = -374 \text{ kJ}$). If a catalyst was added to the system, all of the following would be affected in the system except:
 - a. an increase in ΔH
 - b. an increase the rate of the reverse reaction.
 - c. an increase the rate of the forward reaction.
 - d. a change in the reaction path
5. Of the four factors listed below, which factors would not be determined by the value of the equilibrium constant for the following equation: $2 \text{NaNO}_3(s) \rightleftharpoons 2 \text{NaNO}_2(s) + \text{O}_2(g)$? i. concentration of $\text{NaNO}_3(s)$ ii. concentration of $\text{NaNO}_2(s)$ iii. concentration of $\text{O}_2(g)$ iv. addition of a catalyst
 - a. i and ii only
 - b. iii and iv only
 - c. i and iii only
 - d. i, ii and iv only
6. In the reaction $\text{C}(s) + \text{O}_2(g) \rightleftharpoons \text{CO}_2(g)$ ($\Delta H = -393.5 \text{ kJ/mol}$), what would Le Châtelier's principle suggest as a way to increase the concentration of CO_2 ?
 - a. add a catalyst
 - b. increase O_2
 - c. increase the pressure
 - d. increase the temperature
7. Predict the effect on the chemical equilibrium when each of the following changes is made to this reaction at equilibrium: $\text{H}_2\text{O}(g) + \text{CO}(g) \rightleftharpoons \text{H}_2(g) + \text{CO}_2(g)$, $\Delta H = -42 \text{ kJ}$. What will the effect be on the amount of product produced?
 - a. Temperature is increased.

- b. Pressure is increased.
 - c. CO_2 decreases.
 - d. Catalyst is added.
8. Predict the effect on the chemical equilibrium when each of the following changes is made to this reaction at equilibrium: $2 \text{NaHCO}_3(s) \rightleftharpoons \text{Na}_2\text{CO}_3(s) + \text{CO}_2(g) + \text{H}_2\text{O}(g)$, $\Delta H = -635.33 \text{ kJ}$. What will be the effect on the amount of product produced?
- a. Temperature is decreased.
 - b. Pressure is decreased.
 - c. $[\text{Na}_2\text{CO}_3]$ decreases.
 - d. Catalyst is added.
9. Define Le Châtelier's principle.
10. When can Le Châtelier's principle be applied?
11. Give an example of how Le Châtelier's principle can be used to generate more products for a reaction at equilibrium.
12. Predict the effect on the chemical equilibrium when each of the following changes is made to this reaction at equilibrium: $2 \text{SO}_3(g) + \text{heat} \rightleftharpoons 2 \text{SO}_2(g) + \text{O}_2(g)$. What will the effect be on the amount of product produced?
- a. Temperature is increased.
 - b. Pressure is increased.
 - c. $[\text{O}_2]$ decreases.
 - d. Catalyst is added.
13. Predict the effect on the chemical equilibrium when each of the following changes is made to this reaction at equilibrium: $2 \text{N}_2\text{O}_4(g) + \text{heat} \rightleftharpoons 2 \text{NO}_2(g)$. What will the effect be on the amount of product produced?
- a. Temperature is decreased.
 - b. Pressure is decreased.
 - c. $[\text{N}_2\text{O}_4]$ decreases.
 - d. Catalyst is added.

19.4 Slightly Soluble Salts

Lesson Objectives

The student will:

- define solubility product constants.
- write solubility product constant expressions.
- calculate solubility product constants.

Vocabulary

- solubility product constant

Introduction

Since equilibrium constant expressions omit solids, the equilibrium constant expressions for the dissolution of a salt will have a denominator of 1, so no denominator will be shown. Here are some examples with their equilibrium constant expressions.

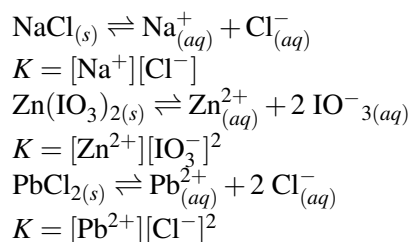

In this final section of the chapter, we will look at solubility equilibria.

Salts in an Equilibrium System

Consider the dissociation reaction for copper(II) hydroxide:

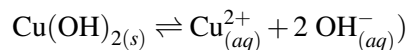

The equilibrium constant for this reaction is very low with a value of 2.2×10^{-20} . A very small value for K means that the reactant (the solid salt) is heavily favored, so very few Cu^{2+} and OH^{-} ions will actually be formed when $\text{Cu}(\text{OH})_2$ is allowed to dissolve in water. In other words, the solution will become saturated very quickly.

This type of equilibrium will be established for any saturated solution that also contains some of the solid salt. When writing the equilibrium expression for a dissociation reaction, the equilibrium constant is often given the subscript “sp,” which stands for solubility product. The **solubility product constant** K_{sp} works the same as any other equilibrium constant, but because calculations for this type of reaction are often quite similar, they are frequently differentiated in this way.

Example:

Tooth enamel is composed of the compound hydroxyapatite, $\text{Ca}_5(\text{PO}_4)_3\text{OH}$, which has a K_{sp} value of 6.8×10^{-37} . Write the dissociation equation and comment on the value of the equilibrium constant.

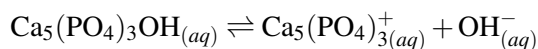
Solution:

The equilibrium constant is very small, so the reactants are heavily favored. This means that tooth enamel will not dissolve readily in water (definitely a good thing).

Example: Write the dissociation reaction and the solubility product constant expression for each of the following solids.

1. $\text{PbSO}_4(s)$
2. $\text{Al}(\text{OH})_3(s)$

Solution:

1. $\text{PbSO}_4(s) \rightleftharpoons \text{Pb}^{2+}_{(aq)} + \text{SO}_4^{2-}_{(aq)} \quad K_{sp} = [\text{Pb}^{2+}][\text{SO}_4^{2-}]$
2. $\text{Al}(\text{OH})_3(s) \rightleftharpoons \text{Al}^{3+}_{(aq)} + 3 \text{OH}^-_{(aq)} \quad K_{sp} = [\text{Al}^{3+}][\text{OH}^-]^3$

Calculating K

The K_{sp} of a slightly soluble salt can be calculated from its solubility. Solubilities are usually given in grams/liter, or occasionally moles/liter. If the solubility is given in moles/liter, you can follow the same process as demonstrated below, except you would skip the first step.

Given the solubility of copper(I) bromide (0.0287 grams/liter H_2O), the molarity of a saturated CuBr solution can be determined. From that value, we can find the concentrations of the individual ions.

$$\text{CuBr dissolved} = \frac{0.0287 \text{ g/L}}{143.5 \text{ g/mol}} = 0.000200 \text{ M} = 2.00 \times 10^{-4} \text{ M}$$

$$\text{CuBr}_{(s)} \rightleftharpoons \text{Cu}^+_{(aq)} + \text{Br}^-_{(aq)}$$

In this case, one Cu^+ ion and one Br^- ion is formed from each formula unit of CuBr , so when 2.00×10^{-4} mol/L of CuBr dissolves, the concentration of the ions in solution will be $[\text{Cu}^+] = 2.00 \times 10^{-4}$ mol/L and $[\text{Br}^-] = 2.00 \times 10^{-4}$ mol/L.

The K_{sp} expression for CuBr is $K_{sp} = [\text{Cu}^+][\text{Br}^-]$. Substituting the calculated values into the K_{sp} expression will give:

$$K_{sp} = [\text{Cu}^+][\text{Br}^-] = (2.00 \times 10^{-4})(2.00 \times 10^{-4}) = 4.00 \times 10^{-8}.$$

The process is only slightly more complicated for salts that dissociate into more than two ions. Consider the salt calcium phosphate. The solubility of calcium phosphate is 5.10×10^{-5} g/L. First, we convert the solubility in grams/liter to moles/liter.

$$\text{molarity Ca}_3(\text{PO}_4)_2 \text{ dissolved} = \frac{5.10 \times 10^{-5} \text{ g/L}}{310. \text{ g/mol}} = 1.67 \times 10^{-7} \text{ M}$$

Then, using the dissolving equation, we determine the molarity of the ions in solution.

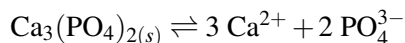

For every mol/L of calcium phosphate that dissolves, there will be 3 times as many calcium ions and 2 times as many phosphate ions in solution. Therefore,

$$\begin{aligned} [\text{Ca}^{2+}] &= (3)(1.67 \times 10^{-7} \text{ M}) = 5.01 \times 10^{-7} \text{ M} \\ [\text{PO}_4^{3-}] &= (2)(1.67 \times 10^{-7} \text{ M}) = 3.34 \times 10^{-7} \text{ M} \end{aligned}$$

We finish the calculation by writing the K_{sp} expression and substituting the molarities of the ions into the expression and calculate.

$$K_{sp} = [\text{Ca}^{2+}]^3[\text{PO}_4^{3-}]^2 = (5.01 \times 10^{-7})^3(3.34 \times 10^{-7})^2 = 1.4 \times 10^{-32}$$

Calculating Solubility From K

Not only can K_{sp} be calculated from the solubility, but the solubility can be calculated from the K_{sp} value. Given the K_{sp} for AgBr ($K_{sp} = 1.60 \times 10^{-10}$), we can use the dissociation equation and some algebra to calculate the concentrations of each ion in solution.

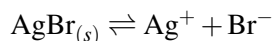

If we allow x to represent the moles of AgBr that dissolves in one liter of water, $[\text{Ag}^+] = x$ and $[\text{Br}^-] = x$, since only one of each ion is produced per formula unit of AgBr. We can then write the K_{sp} expression for AgBr, set it equal to the given K_{sp} value, substitute the assigned variables into the equation, and solve.

$$\begin{aligned} K_{sp} &= [\text{Ag}^+][\text{Br}^-] = 1.60 \times 10^{-10} \\ (x)(x) &= 1.60 \times 10^{-10} \\ x &= 1.26 \times 10^{-5} \text{ M} \end{aligned}$$

Because of how we defined x , we can see that the molarity of AgBr will be the same so the solubility of AgBr is $1.26 \times 10^{-5} \text{ M}$. To find the solubility of AgBr in grams/liter, we simply need to multiply the molarity by the molar mass.

$$\text{Solubility of AgBr in g/L} = (1.26 \times 10^{-5} \text{ mol/L})(188 \text{ g/mol}) = 2.4 \times 10^{-3} \text{ g/L}$$

This problem becomes slightly more difficult when the salt generates more than two ions. Let's try lead(II) fluoride. Here is the dissolving equation, the K_{sp} expression, and the K_{sp} value for PbF_2 :

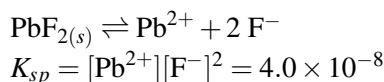

Once again, we let x represent the solubility of PbF_2 in moles/liter. Therefore, the concentration of lead ions in solution will be x and the concentration of fluoride ions in solution will be $2x$. Substitute these variables into the K_{sp} expression and solve for x .

$$\begin{aligned} [\text{Pb}^{2+}][\text{F}^-]^2 &= 4.0 \times 10^{-8} \\ (x)(2x)^2 &= 4.0 \times 10^{-8} \end{aligned}$$

$$4x^3 = 4.0 \times 10^{-8}$$

$$x^3 = 1.0 \times 10^{-8}$$

$$x = 2.2 \times 10^{-3} \text{ mol/L}$$

When we assigned the variables, x represented the molarity of the lead ions in solution, but x also represented the molarity of lead(II) fluoride that had dissolved, so this is the solubility in moles/liter. To get grams/liter, we multiply by the molar mass.

$$\text{Solubility of PbF}_2 = (2.2 \times 10^{-3} \text{ mol/L})(245 \text{ g/mol}) = 0.53 \text{ g/L}$$

You should look back at the assignment of variables and determine the molarity of fluoride ions in solution. There will be questions where you are asked to find the concentrations of the ions in solution from K_{sp} . You would use this same process, but the desired answer may not always be equal to x .

Lesson Summary

- Equilibrium constants for slightly soluble salts are called solubility product constants.

Review Questions

- What is the solubility product constant? Give an example.
- Why is solubility considered a special case for chemical equilibria?
- Nickel hydroxide is a slightly soluble salt. Its dissociation reaction is represented as: $\text{Ni(OH)}_{2(s)} \rightleftharpoons \text{Ni}_{(aq)}^{2+} + 2 \text{OH}_{(aq)}^-$. Which of the following represents the solubility product constant expression, K_{sp} ?
 - $K_{sp} = \frac{[\text{Ni}^{2+}][\text{OH}^-]}{[\text{Ni(OH)}_2]}$
 - $K_{sp} = \frac{[\text{Ni}^{2+}][\text{OH}^-]^2}{[\text{Ni(OH)}_2]}$
 - $K_{sp} = [\text{Ni}^{2+}][\text{OH}^-]$
 - $K_{sp} = [\text{Ni}^{2+}][\text{OH}^-]^2$
- The K_{sp} for AgBr is 5.0×10^{-13} . What is $[\text{Ag}^+]$ at equilibrium?
 - $5.0 \times 10^{-13} \text{ mol/L}$
 - $7.1 \times 10^{-7} \text{ mol/L}$
 - $2.5 \times 10^{-13} \text{ mol/L}$
 - not enough information is given
- The K_{sp} for PbF_2 is 3.60×10^{-8} . What is $[\text{F}^-]$ at equilibrium?
 - $3.60 \times 10^{-8} \text{ mol/L}$
 - $3.33 \times 10^{-3} \text{ mol/L}$
 - $4.16 \times 10^{-3} \text{ mol/L}$
 - $2.08 \times 10^{-3} \text{ mol/L}$
- Magnesium hydroxide is the active component in milk of magnesia, a suspension used to cure indigestion. It has an equilibrium constant of 6.3×10^{-10} . Write the dissociation equation and comment on the value of the equilibrium constant.
- Write the dissociation reactions for the following salts as well as the K_{sp} expressions.
 - calcium fluoride

- b. chromium(II) carbonate
- c. arsenic(III) sulfide

All images, unless otherwise stated, are created by the CK-12 Foundation and are under the Creative Commons license CC-BY-NC-SA.

CHAPTER 20**Acids and Bases****Chapter Outline**

- 20.1 PROPERTIES OF ACIDS AND BASES**
 - 20.2 ARRHENIUS ACIDS AND BASES**
 - 20.3 THE PH CONCEPT**
 - 20.4 STRENGTH OF ACIDS AND BASES**
 - 20.5 BRØNSTED-LOWRY ACIDS AND BASES**
 - 20.6 LEWIS ACIDS AND BASES**
-

20.1 Properties of Acids and Bases

Lesson Objectives

The student will:

- list the properties of acids.
- list the properties of bases.
- name an acid or base when given the formula.
- write the formula for an acid or base given the name.

Vocabulary

- indicators

Introduction

We interact with acids on a daily basis without even realizing it. For example, the chemical names for aspirin and vitamin C are acetylsalicylic acid and ascorbic acid; both will produce H^+ ions when dissolved in water. Acetic acid ($HC_2H_3O_2$) is the primary component in vinegar, and formic acid (HCO_2H) is what causes ant bites to sting. Hydrochloric acid (HCl) is stomach acid, phosphoric acid (H_3PO_4) is commonly found in dark soft drinks, and sulfuric acid (H_2SO_4) is used in car batteries. As you work your way through this chapter, try to notice how the properties of acids and bases manifest themselves in everyday situations.

Properties of Acids

One property that is common to all acids is a sour taste. You are probably most familiar with this in relation to citric acid, which is what makes lemons and other citrus fruits taste sour. In fact, sour taste buds are essentially just complicated H^+ sensors. The fact that one of our primary tastes is concerned solely with determining the acidity of what goes in our mouths further underscores the importance of acids in our lives.

However, testing whether something is acidic by taste is generally not a good idea. Another way to test for acidity is to use an indicator. **Indicators** are substances that can be used to determine the relative acidity or basicity of a solution, generally through a very distinct color change.

One common type of indicator is litmus paper. If a piece of blue litmus paper turns red when dipped into a solution, it means that the solution is acidic.

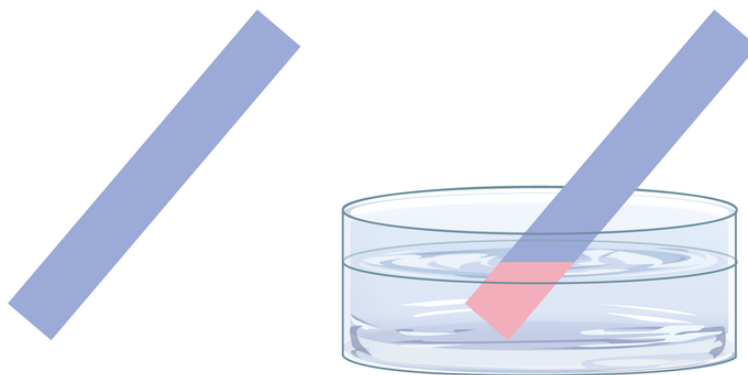

Another property common to many acids is that they can react with certain metals to form hydrogen gas. Examples of this type of reaction are shown below. Note that these are all single replacement reactions where a pure element reacts with a compound

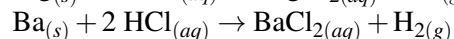
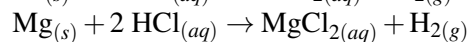
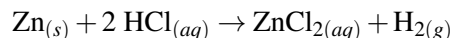

Names and Formulas of Acids

The chemical formula for an acid typically begins with one or more hydrogen atoms. This means that hydrogen is the cation. The name of an acid depends on the anion. When the anion ends in “-ide,” such as chloride or sulfide, the prefix “hydro-” is used before the name of the nonmetal, and its “-ide” ending is replaced by “-ic acid.” For example, the acid HCl is named hydrochloric acid. The anion is chloride, so the prefix “hydro-” is used, and the “-ide” ending is replaced by “-ic acid.”

When the anion ends in “-ate,” such as sulfate and phosphate, the “-ate” is replaced by “-ic acid.” For example, the acid HNO₃ is named nitric acid. The anion is nitrate, so the “-ate” ending is replaced by “-ic” acid.

When the anion ends in “-ite,” such as nitrite or sulfite, the “-ite” is replaced by “-ous acid.” For example, the acid HClO₂ is named chlorous acid. The anion is chlorite, so the “-ite” is replaced by “-ous acid.”

Example:

Write the names of each of the following acids:

1. HF
2. HNO₂
3. H₂SO₄

Solution:

1. hydrofluoric acid
2. nitrous acid
3. sulfuric acid

Properties of Bases

Bases also have a number of characteristic properties. Most bases are slippery and quite bitter (though not all bitter compounds are basic). Caffeine and milk of magnesia (chemical formula $\text{Mg}(\text{OH})_2$) are two bases that you may have had the opportunity to taste, although the bitterness is generally masked by other flavors when these compounds are consumed. Other common bases are found in a number of cleaning products, including Drano (NaOH) and Windex (NH_4OH).

Like acids, bases can be identified by the use of an indicator. For example, if red litmus paper is dipped into a basic solution, it will turn blue.

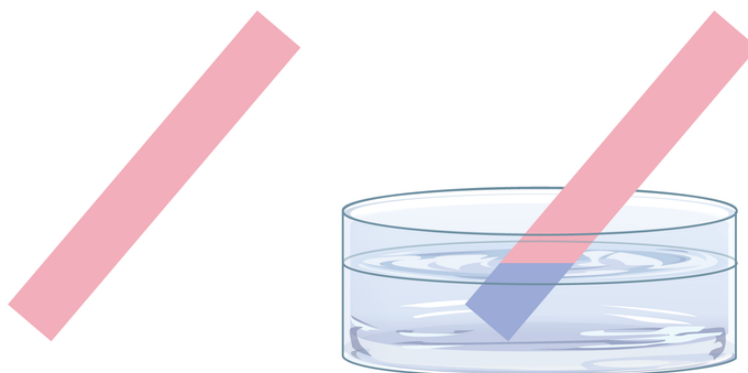

This video discusses the properties of acids and bases (5a): <http://www.youtube.com/watch?v=mm7Hcff5b6g> (8:02).

- Another property that can be used to distinguish acids from bases is their conductivity in solution. $\text{HCl} \rightarrow \text{H}^+ + \text{Cl}^-$
- Aqueous solutions of acids and bases conduct electricity.
- Proof that ions are present in acidic and basic solutions.



MEDIA

Click image to the left for more content.

A discussion of the difference between strong and weak acids is available at (5c) <http://www.youtube.com/watch?v=XTdkWGImtSc> (9:47).

ACID - A SUBSTANCE THAT DONATES A PROTON
 BASE - ACCEPTS A PROTON

Ex: $\text{HCl}(\text{aq}) + \text{H}_2\text{O} \rightarrow \text{H}_3\text{O}^+ + \text{Cl}^-$

HCl }
 B-L ACID }
 H_2O }
 H_3O^+ }
 Cl^- }
 }
 } BASE

MEDIA

Click image to the left for more content.

Names and Formulas of Bases

The chemical formula for a strong base often ends with one or more hydroxide (OH^-) ions. This means that hydroxide is the anion. This type of base is named in the same way as any other ionic compound.

Example:

Write the names of each of the following bases.

1. NaOH
2. KOH
3. $\text{Ca}(\text{OH})_2$

Solution:

1. sodium hydroxide
2. potassium hydroxide
3. calcium hydroxide

Lesson Summary

- Acids turn blue litmus paper red, taste sour, and react with metals to produce hydrogen gases.
- Common acids include vinegar ($\text{HC}_2\text{H}_3\text{O}_2$) and stomach acid (HCl).
- Bases turn red litmus paper blue, have a bitter taste, and are slippery to the touch.
- Common bases include Drano (NaOH), soft soap (KOH), milk of magnesia ($\text{Mg}(\text{OH})_2$), and Windex (NH_4OH).

Further Reading / Supplemental Links

Visit this website to learn more about examples and properties of acids and bases.

- <http://qldscienceteachers.tripod.com/junior/chem/acid.html>

Review Questions

1. What are the properties of acids? Give a common example.
2. Which statement best describes a characteristic of acid solutions?
 - a. They react with some metals to form hydrogen gas.
 - b. They turn red litmus paper blue.
 - c. They taste bitter.
 - d. They are made from nonmetal oxides.
3. Write the reaction between:
 - a. magnesium and sulfuric acid.
 - b. calcium and acetic acid.

4. Which of the following will react with acids and produce hydrogen gas?
- chlorine
 - ammonia
 - carbon
 - magnesium

20.2 Arrhenius Acids and Bases

Lesson Objectives

The student will:

- define an Arrhenius acid and list some substances that qualify as acids under this definition.
 - define an Arrhenius base and list some substances that qualify as bases under this definition.
-

Vocabulary

- Arrhenius acid
 - Arrhenius base
-

Introduction

Work done by Svante Arrhenius in the late 19th century set the groundwork for our current understanding of acid-base theory. Despite the relatively limited technology available to him, he was able to develop theories that adequately explained the properties and chemical reactivity of many acids and bases. Subsequent research led to the development of other commonly used definitions for acids and bases, but for now, we will focus on those proposed by Arrhenius.

Definitions

Take a look at the following dissociation reactions:

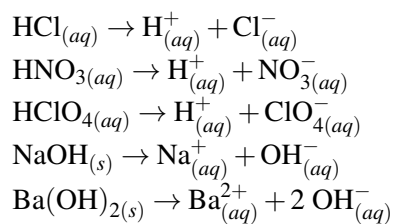

If you look at the products, you will notice some common features. All of the acids have H^{+} as one of the resulting ions, and all the bases produce OH^{-} . It was on the basis of this observation that Arrhenius settled on his definitions for acids and bases. An **Arrhenius acid** is a substance that produces H^{+} ions in solution, and an **Arrhenius base** is a substance that produces OH^{-} ions in solution.

Identifying Arrhenius Acids and Bases

How can we identify an acid or a base simply by looking at the chemical formula? Since we have defined acids and bases by the ions they release in solution, the first requirement is that they contain H or OH, respectively. However, there are plenty of compounds that contain oxygen and hydrogen atoms that are not acids and bases. What other clues can we look for?

Arrhenius bases are easy to spot because basically all of them are salts where the cation is a metal (or ammonium) and the anion is hydroxide. Due to the way we name ionic compounds, these substances will also have “hydroxide” in the name.

Acids can sometimes be a little trickier if all you have is the formula. For many of the acids that you will encounter, the formula will begin with an H: H_2SO_4 , HCl , HNO_3 , and HClO_4 are all acids. When a formula involves hydrogen plus an anion that you are familiar with, it is highly likely that the compound is an acid.

One common type of weak acid is generally written in the form R-COOH or $\text{R-CO}_2\text{H}$, where R is usually a hydrocarbon. An example is acetic acid, which is usually written as $\text{CH}_3\text{CO}_2\text{H}$. In solution, acetic acid dissociates to form acetate (CH_3CO_2^-) and H^+ . Other acids of this type have similar dissociation reactions. Note that when written in the form R-COOH , these compounds may appear to have an available hydroxide anion. Don't be fooled! When OH is attached to something covalently, it will not release when dissolved into solution.

Example:

Write the dissociation equation for the following compounds and state whether each is an acid, a base, or neither.

1. H_2SO_4
2. LiOH
3. NaNO_3
4. $\text{C}_6\text{H}_5\text{COOH}$
5. NaOH
6. KOH

Solution:

1. acid, $\text{H}_2\text{SO}_{4(aq)} \rightarrow 2 \text{H}_{(aq)}^+ + \text{SO}_{4(aq)}^{2-}$
2. base, $\text{LiOH}_{(s)} \rightarrow \text{Li}_{(aq)}^+ + \text{OH}_{(aq)}^-$
3. neither, $\text{NaNO}_{3(s)} \rightarrow \text{Na}_{(aq)}^+ + \text{NO}_{3(aq)}^-$
4. acid, $\text{C}_6\text{H}_5\text{COOH}_{(aq)} \rightarrow \text{H}_{(aq)}^+ + \text{C}_6\text{H}_5\text{COO}_{(aq)}^-$
5. base, $\text{NaOH}_{(s)} \rightarrow \text{Na}_{(aq)}^+ + \text{OH}_{(aq)}^-$
6. base, $\text{KOH}_{(s)} \rightarrow \text{K}_{(aq)}^+ + \text{OH}_{(aq)}^-$

Lesson Summary

- Arrhenius defined an acid as a substance that donates H^+ ions when dissociating in solution.
- An Arrhenius base is a substance that releases OH^- ions in solution.

Review Questions

1. Which of the following is the Arrhenius definition of an acid?
 - a. An acid is a substance that donates protons.
 - b. An acid is a substance that accepts protons.
 - c. An acid is a substance that dissolves in water to form OH^- ions.
 - d. An acid is a substance that reacts with water to form H^+ ions.

20.3 The pH Concept

Lesson Objectives

The student will:

- calculate $[H^+]$ and $[OH^-]$ for a solution of acid or base.
- define autoionization.
- state the $[H^+]$, $[OH^-]$, and K_w values for the autoionization of water.
- define pH and describe the pH scale.
- write the formulas for pH and pOH and express their values in a neutral solution at $25^\circ C$.
- explain the relationships among pH, pOH, and K_w .
- calculate $[H^+]$, $[OH^-]$, pH, and pOH given the value of any one of the other values.
- explain the relationship between the acidity or basicity of a solution and the hydronium ion concentration, $[H_3O^+]$, and the hydroxide ion concentration, $[OH^-]$, of the solution.
- predict whether an aqueous solution is acidic, basic, or neutral from $[H_3O^+]$, $[OH^-]$, or the pH.

Vocabulary

- autoionization
- hydronium ion
- ion product constant for water (K_w)
- pH
- pOH

Introduction

We have learned many properties of water, such as pure water does not conduct electricity. The reason pure water does not conduct electricity is because the concentration of ions present when water ionizes is small. In this lesson, we will look a little closer at this property of water and how it relates to acids and bases.

The Hydronium Ion

Recall that ions in solution are hydrated. That is, water molecules are loosely bound to the ions by the attraction between the charge on the ion and the oppositely charged end of the polar water molecules, as illustrated in the figure below. When we write the formula for these ions in solution, we do not show the attached water molecules. It is simply recognized by chemists that ions in solution are always hydrated.

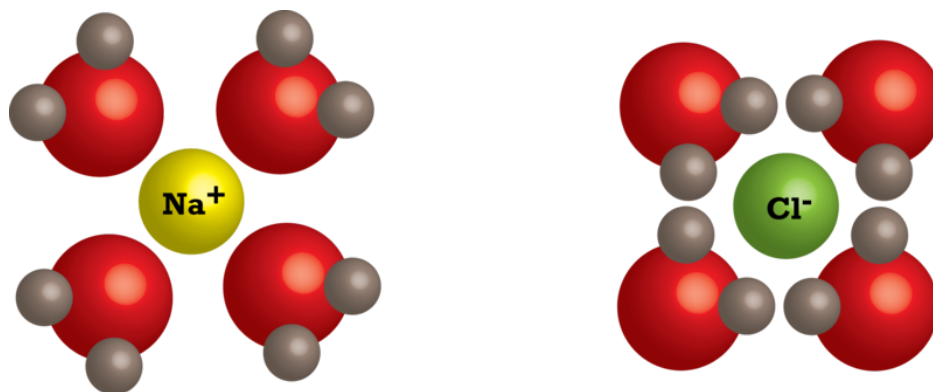

As with any other ion, a hydrogen ion dissolved in water will be closely associated with one or more water molecules. This fact is sometimes indicated explicitly by writing the **hydronium ion**, H_3O^+ , in place of the hydrogen ion, H^+ . Many chemists still use $\text{H}_{(aq)}^+$ to represent this situation, but it is understood that this is just an abbreviation for what is really occurring in solution. You are likely to come across both, and it is important for you to understand that they are actually describing the same entity. When using the hydronium ion in a chemical equation, you may need to add a molecule of water to the other side so that the equation will be balanced. This is illustrated in the equations below. Note that you are not really adding anything to the reaction. The *(aq)* symbol indicates that the various reaction components are dissolved in water, so writing one of these water molecules out explicitly in the equation does not change the reaction conditions.

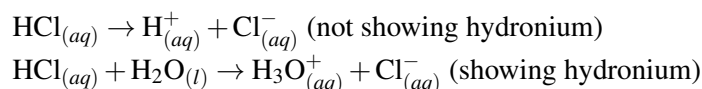

Relationship Between [H]

Even totally pure water will contain a small amount of H^+ and OH^- . This is because water undergoes a process known as autoionization. **Autoionization** occurs when the same reactant acts as both the acid and the base. Look at the reaction below.

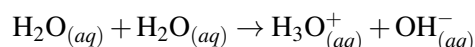

The ionization of water is frequently written as:

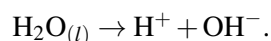

The equilibrium constant expression for this dissociation would be $K_w = [\text{H}^+][\text{OH}^-]$. From experimentation, chemists have determined that in pure water, $[\text{H}^+] = 1 \times 10^{-7}$ mol/L and $[\text{OH}^-] = 1 \times 10^{-7}$ mol/L.

Because this is a particularly important equilibrium, the equilibrium constant is given a subscript to differentiate it from other reactions. K_w , also known as the **ion product constant for water**, always refers to the autoionization of water. We can calculate K_w because we know the value of $[\text{H}^+]$ and $[\text{OH}^-]$ for pure water at 25°C.

$$K_w = [\text{H}^+][\text{OH}^-]$$

$$K_w = (1 \times 10^{-7})(1 \times 10^{-7})$$

$$K_w = 1 \times 10^{-14}$$

A further definition of acids and bases can now be made:

When $[\text{H}_3\text{O}^+] = [\text{OH}^-]$ (as in pure water), the solution is *neutral*.

When $[\text{H}_3\text{O}^+] > [\text{OH}^-]$, the solution is an *acid*.

When $[\text{H}_3\text{O}^+] < [\text{OH}^-]$, the solution is a *base*.

Stated another way, an acid has a $[\text{H}_3\text{O}^+]$ that is greater than 1×10^{-7} and a $[\text{OH}^-]$ that is less than 1×10^{-7} . A base has a $[\text{OH}^-]$ that is greater than 1×10^{-7} and a $[\text{H}_3\text{O}^+]$ that is less than 1×10^{-7} .

The equilibrium between H^+ , OH^- , and H_2O will exist in all water solutions, regardless of anything else that may be present in the solution. Some substances that are placed in water may become involved with either the hydrogen or hydroxide ions and alter the equilibrium state. However, as long as the temperature is kept constant at 25°C , the equilibrium will shift to maintain the equilibrium constant, K_w , at exactly 1×10^{-14} .

For example, a sample of pure water at 25°C has $[\text{H}^+]$ equal to 1×10^{-7} M and $[\text{OH}^-] = 1 \times 10^{-7}$ M. The K_w for this solution, of course, will be 1×10^{-14} . Suppose some HCl gas is added to this solution so that the H^+ concentration increases. This is a stress to the equilibrium system. Since the concentration of a product is increased, the reverse reaction rate will increase and the equilibrium will shift toward the reactants. The concentrations of both ions will be reduced until equilibrium is re-established. If the final $[\text{H}^+] = 1 \times 10^{-4}$ M, we can calculate the $[\text{OH}^-]$ because we know that the product of $[\text{H}^+]$ and $[\text{OH}^-]$ at equilibrium is always 1×10^{-14} .

$$K_w = [\text{H}^+][\text{OH}^-] = 1 \times 10^{-14}$$

$$[\text{OH}^-] = \frac{1 \times 10^{-14}}{[\text{H}^+]} = \frac{1 \times 10^{-14}}{1 \times 10^{-4}} = 1 \times 10^{-10} \text{ M}$$

Suppose, on the other hand, something is added to the solution that reduces the hydrogen ion concentration. As soon as the hydrogen ion concentration begins to decrease, the reverse rate decreases and the forward rate will shift the equilibrium toward the products. The concentrations of both ions will be increased until equilibrium is re-established. If the final hydrogen ion concentration is 1×10^{-12} M, we can calculate the final hydroxide ion concentration.

$$K_w = [\text{H}^+][\text{OH}^-] = 1 \times 10^{-14}$$

$$[\text{OH}^-] = \frac{1 \times 10^{-14}}{[\text{H}^+]} = \frac{1 \times 10^{-14}}{1 \times 10^{-12}} = 1 \times 10^{-2} \text{ M}$$

Using the K_w expression and our knowledge of the K_w value, as long as we know either the $[\text{H}^+]$ or the $[\text{OH}^-]$ in a water solution, we can always calculate the value for the other one.

Example:

What would be the $[\text{H}^+]$ for a grapefruit found to have a $[\text{OH}^-]$ of 1.26×10^{-11} mol/L? Is the solution acidic, basic, or neutral?

Solution:

$$K_w = [\text{H}^+][\text{OH}^-] = 1.00 \times 10^{-14}$$

$$[\text{H}^+] = \frac{1 \times 10^{-14}}{[\text{OH}^-]} = \frac{1 \times 10^{-14}}{1.26 \times 10^{-11}} = 7.94 \times 10^{-4} \text{ M}$$

Since the $[\text{H}^+]$ in this solution is greater than 1×10^{-7} M, the solution is acidic.

pH and pOH

There are a few very concentrated acid and base solutions used in industrial chemistry and laboratory situations. For the most part, however, acid and base solutions that occur in nature, used in cleaning, and used in biochemistry applications are relatively dilute. Most of the acids and bases dealt with in laboratory situations have hydrogen ion

concentrations between 1.0 M and 1.0×10^{-14} M. Expressing hydrogen ion concentrations in exponential numbers can become tedious, so a Danish chemist named Søren Sørensen developed a shorter method for expressing acid strength or hydrogen ion concentration with a non-exponential number. This value is referred to as **pH** and is defined by the following equation:

$$\text{pH} = -\log[\text{H}^+],$$

where $p = -\log$ and H refers to the hydrogen ion concentration. The p from pH comes from the German word *potenz*, meaning power or the exponent of. Rearranging this equation to solve for $[\text{H}^+]$, we get $[\text{H}^+] = 10^{-\text{pH}}$. If the hydrogen ion concentration is between 1.0 M and 1.0×10^{-14} M, the value of the pH will be between 0 and 14.

Example:

Calculate the pH of a solution where $[\text{H}^+] = 0.01$ mol/L.

Solution:

$$\begin{aligned}\text{pH} &= -\log(0.01) \\ \text{pH} &= -\log(1 \times 10^{-2}) \\ \text{pH} &= 2\end{aligned}$$

Example:

Calculate the $[\text{H}^+]$ if the pH is 4.

Solution:

$$\begin{aligned}[\text{H}^+] &= 10^{-\text{pH}} \\ [\text{H}^+] &= 10^{-4} \\ [\text{H}^+] &= 1 \times 10^{-4} \text{ mol/L}\end{aligned}$$

Example:

Calculate the pH of saliva, where $[\text{H}^+] = 1.58 \times 10^{-6}$ mol/L.

Solution:

$$\begin{aligned}\text{pH} &= -\log[\text{H}^+] = -\log(1.58 \times 10^{-6}) \\ \text{pH} &= 5.8\end{aligned}$$

Example:

Fill in the rest of **Table 20.1**.

TABLE 20.1: Hydrogen ion concentration and corresponding pH.

$[\text{H}^+]$ in mol/L	$-\log[\text{H}^+]$	pH
0.1	1.00	1.00
0.2	0.70	0.70
1×10^{-5}	?	?
?	?	6.00
0.065	?	?
?	?	9.00

Solution:

The completed table is shown below (Table 20.2).

TABLE 20.2: Hydrogen ion concentration and corresponding pH.

$[\text{H}^+]$ in mol/L	$-\log[\text{H}^+]$	pH
0.1	1.00	1.00
0.2	0.70	0.70
1.00×10^{-5}	5	5
1.00×10^{-6}	6.00	6.00
0.065	1.19	1.19
1.00×10^{-9}	9.00	9.00

An acid with $\text{pH} = 1$, then, is stronger than an acid with $\text{pH} = 2$ by a factor of 10. Simply put, lower pH values correspond to higher H^+ concentrations and more acidic solutions, while higher pH values correspond to higher OH^- concentrations and more basic solutions. This is illustrated in the figure below. It should be pointed out that there are acids and bases that fall outside the pH range depicted. However, we will confine ourselves for now to those falling within the 0-14 range, which covers $[\text{H}^+]$ values from 1.0 M all the way down to 1×10^{-14} M.

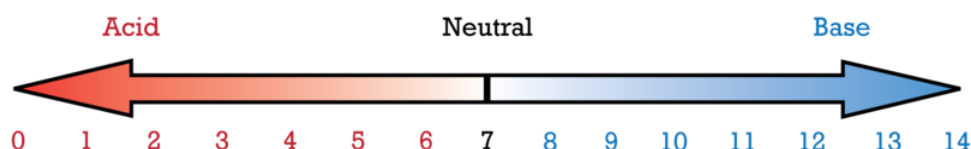
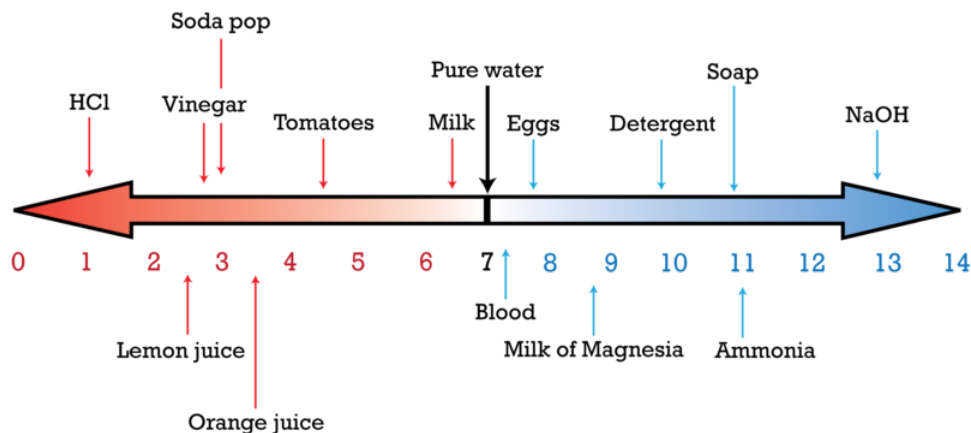

TABLE 20.3: pH versus Acidity

pH level	Solution
$\text{pH} < 7$	Acid
$\text{pH} = 7$	Neutral
$\text{pH} > 7$	Basic

Have you ever cut an onion and had your eyes water up? This is because of a compound with the formula $\text{C}_3\text{H}_6\text{OS}$ that is found in onions. When you cut the onion, a variety of reactions occur that release a gas. This gas can diffuse into the air and eventually mix with the water found in your eyes to produce a dilute solution of sulfuric acid. This is what irritates your eyes and causes them to water. There are many common examples of acids and bases in our everyday lives. Look at the pH scale below to see how these common examples relate in terms of their pH.



Even though both acidic and basic solutions can be expressed by pH, an equivalent set of expressions exists for the concentration of the hydroxide ion in water. This value, referred to as **pOH**, is defined as:

$$\text{pOH} = -\log[\text{OH}^-]$$

If the pOH is greater than 7, the solution is acidic. If the pOH is equal to 7, the solution is neutral. If the pOH is less than 7, the solution is basic.

If we take the negative log of the complete K_w expression, we obtain:

$$\begin{aligned} K_w &= [\text{H}^+][\text{OH}^-] \\ -\log K_w &= (-\log[\text{H}^+]) + (-\log[\text{OH}^-]) \\ -\log(1 \times 10^{-14}) &= (-\log[\text{H}^+]) + (-\log[\text{OH}^-]) \\ 14 &= \text{pH} + \text{pOH} \end{aligned}$$

Therefore, the sum of the pH and the pOH is always equal to 14 (at 25°C). Remember that the pH scale is written with values from 0 to 14 because many useful acid and base solutions fall within this range. Now let's go through a few examples to see how this calculation works for problem-solving in solutions with an added acid or base.

Example:

What is the $[\text{H}^+]$ for a solution of NH_3 whose $[\text{OH}^-] = 8.23 \times 10^{-6}$ mol/L?

Solution:

$$\begin{aligned} [\text{H}_3\text{O}^+][\text{OH}^-] &= 1.00 \times 10^{-14} \\ [\text{H}_3\text{O}^+] &= \frac{1.00 \times 10^{-14}}{[\text{OH}^-]} = \frac{1.00 \times 10^{-14}}{8.23 \times 10^{-6}} = 1.26 \times 10^{-9} \text{ M} \end{aligned}$$

Example:

Black coffee has a $[\text{H}_3\text{O}^+] = 1.26 \times 10^{-5}$ mol/L. What is the pOH?

Solution:

$$\begin{aligned} \text{pH} &= -\log[\text{H}^+] = -\log 1.26 \times 10^{-5} = 4.90 \\ \text{pH} + \text{pOH} &= 14 \\ \text{pOH} &= 14 - \text{pH} = 14 - 4.90 = 9.10 \end{aligned}$$

For a classroom demonstration of pH calculations (**5d, 5f; 1e IE Stand.**), see http://www.youtube.com/watch?v=1ca_puB1R8k (9:45).

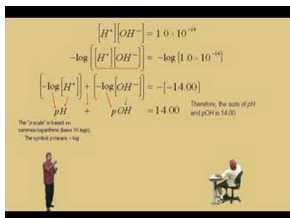

MEDIA

Click image to the left for more content.

Lesson Summary

- Autoionization is the process where the same molecule acts as both an acid and a base.
- Water ionizes to a very slight degree according to the equation $\text{H}_2\text{O}_{(l)} \rightleftharpoons [\text{H}^+] + [\text{OH}^-]$.
- In pure water at 25°C, $[\text{H}^+] = [\text{OH}^-] = 1.00 \times 10^{-7}$ M.
- The equilibrium constant for the dissociation of water, K_w , is equal to 1.00×10^{-14} at 25°C.

- $\text{pH} = -\log[\text{H}^+]$
- $\text{pOH} = -\log[\text{OH}^-]$
- $\text{p}K_w = -\log K_w$
- $\text{pH} + \text{pOH} = \text{p}K_w = 14.0$

Further Reading / Supplemental Links

The websites below have more information about pH.

- <http://www.johnkyrk.com/pH.html>
- <http://purchon.com/chemistry/ph.htm>

Review Questions

1. What is the $[\text{H}^+]$ ion concentration in a solution of 0.350 mol/L H_2SO_4 ?
 - a. 0.175 mol/L
 - b. 0.350 mol/L
 - c. 0.700 mol/L
 - d. 1.42×10^{-14} mol/L
2. A solution has a pH of 6.54. What is the concentration of hydronium ions in the solution?
 - a. 2.88×10^{-7} mol/L
 - b. 3.46×10^{-8} mol/L
 - c. 6.54 mol/L
 - d. 7.46 mol/L
3. A solution has a pH of 3.34. What is the concentration of hydroxide ions in the solution?
 - a. 4.57×10^{-4} mol/L
 - b. 2.19×10^{-11} mol/L
 - c. 3.34 mol/L
 - d. 10.66 mol/L
4. A solution contains 4.33×10^{-8} M hydroxide ions. What is the pH of the solution?
 - a. 4.33
 - b. 6.64
 - c. 7.36
 - d. 9.67
5. Fill in **Table 20.4** and rank the solutions in terms of increasing acidity.

TABLE 20.4: Table for Problem 5

Solutions	$[\text{H}^+]$ (mol/L)	$-\log [\text{H}^+]$	pH
A	0.25	0.60	0.60
B	?	2.90	?
C	1.25×10^{-8}	?	?
D	0.45×10^{-3}	?	?
E	?	1.26	?

6. It has long been advocated that red wine is good for the heart. Wine is considered to be an acidic solution. Determine the concentration of hydronium ions in wine with pH 3.81.
7. What does the value of K_w tell you about the autoionization of water?
8. If the pH of an unknown solution is 4.25, what is the pOH?
 - a. $10^{-4.25}$
 - b. $10^{-9.75}$
 - c. 9.75
 - d. $14.0 - 10^{-9.75}$
9. A solution contains a hydronium ion concentration of 3.36×10^{-4} mol/L. What is the pH of the solution?
 - a. 3.36
 - b. 3.47
 - c. 10.53
 - d. none of the above
10. A solution contains a hydroxide ion concentration of 6.43×10^{-9} mol/L. What is the pH of the solution?
 - a. 5.80
 - b. 6.48
 - c. 7.52
 - d. 8.19
11. An unknown solution was found in the lab. The pH of the solution was tested and found to be 3.98. What is the concentration of hydroxide ions in this solution?
 - a. 3.98 mol/L
 - b. 0.67 mol/L
 - c. 1.05×10^{-4} mol/L
 - d. 9.55×10^{-11} mol/L

20.4 Strength of Acids and Bases

Lesson Objectives

The student will:

- describe the difference between a strong and weak acid.
- identify specific acids as strong or weak.
- define weak acids and bases.
- use K_a or K_b to find $[H^+]$ and vice versa.
- use K_a or K_b to find pH.

Vocabulary

- K_a
- K_b
- strong acid
- strong base
- weak acid
- weak base

Introduction

A great number of people associate strong acids with their ability to react with skin, essentially “melting” it away from bone. On a popular crime show, this very chemistry was used as a method for a crime. The crime show used sulfuric acid. Why sulfuric acid and not acetic acid? What makes the difference? How can we tell if an acid is strong or weak? The answers to these questions will be the focus of the lesson that follows.

Strong Acids and Bases

Strong acids and **strong bases** are those that completely dissociate when dissolved in water. HCl is an example of a strong acid, as seen in the equation below:

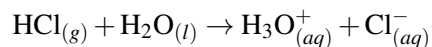

Notice that this equation only has a forward arrow instead of the equilibrium arrows seen in many dissociation reactions. This indicates that the reaction goes to completion, so when the reaction is over, there are essentially no HCl molecules left in solution, only H^+ and Cl^- ions. Since strong acids fully dissociate, many ions are produced, making the solution a good conductor of electricity.

There are only six common strong acids. These acids are shown in **Table 20.5**. Each of the acids found in this table will completely dissociate in water.

TABLE 20.5: Strong Acids

Name	Formula
Hydrochloric acid	HCl
Hydrobromic acid	HBr
Hydroiodic	HI
Nitric acid	HNO ₃
Perchloric acid	HClO ₄
Sulfuric acid	H ₂ SO ₄

Weak Acids and Bases

Weak acids and **weak bases** do *not* completely dissociate when dissolved in water. The less dissociation that takes place, the weaker the acid since there will be fewer H⁺ ions in solution. For example, when acetic acid is placed in water, only about 5% of the acetic acid molecules separate into H⁺ ions and C₂H₃O₂⁻ ions:

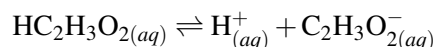

Notice that we now use the equilibrium arrows in the chemical equation. At equilibrium, this solution will contain more acetic acid molecules than hydronium and acetate ions.

Let's look at citric acid, a weak acid. Citric acid, C₆H₈O₇, is commonly found in everyday products like lemons, limes, and soft drinks. It is the substance responsible for making these foods taste sour. If we were to write an ionization equation for citric acid, it would appear as written below:

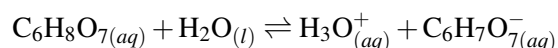

All acids that you will encounter at this level are weak acids if they are not one of the six listed in **Table 20.5** are weak. Even though these weak acids are very soluble in water, they dissolve as molecules, and only a few of the molecules break into ions in the solution. Since weak acids do not produce many ions, a weak acid solution will only conduct a small electric current.

Example:

Write dissociation equations for only those acids that are weak.

1. Sulfuric acid (H₂SO₄)
2. Hydrofluoric acid (HF)
3. Trichloroacetic acid (CCl₃COOH)

Solution:

1. H₂SO₄ is a strong acid (one of the six).
2. HF is a weak acid (not one of the six); $\text{HF}_{(aq)} \rightleftharpoons \text{H}^+_{(aq)} + \text{F}^-_{(aq)}$
3. CCl₃COOH is a weak acid (not one of the six). $\text{CCl}_3\text{COOH}_{(aq)} \rightleftharpoons \text{H}^+_{(aq)} + \text{CCl}_3\text{COO}^-_{(aq)}$

Weak Acids and Weak Bases as Equilibrium Systems

The dissociation of a weak acid is another special type of reaction that is given its own equilibrium constant. The equilibrium constant for the dissociation of a weak acid is designated K_a . The dissociation reaction for acetic acid, one of the primary components of vinegar, is shown below.

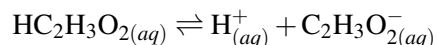

The equilibrium constant, K_a , for acetic acid is 1.8×10^{-5} . This value is small, indicating that the equilibrium position lies more to the left than to the right. In other words, there are more acetic acid molecules at equilibrium than there are acetate ions or hydronium ions. Since K_a is less than 1, we know that $[\text{HC}_2\text{H}_3\text{O}_2] > [\text{C}_2\text{H}_3\text{O}_2^-][\text{H}^+]$ at equilibrium.

Similarly, the equilibrium constant for the reaction between a weak base and water is designated K_b . An example of a weak base reaction is shown below.

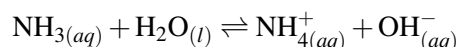

The equilibrium constant for this reaction is, coincidentally, also 1.8×10^{-5} . Again, a value much less than one indicates that the equilibrium favors the reactants. In this solution, very few ammonia molecules are able to remove a proton from water to create ammonium and hydroxide ions.

Example:

Put the following acids in order of decreasing acid strength. Write an equilibrium expression for each. Remember dissociation increases with increasing acid strength (or decreasing pH).

Formic acid (HCOOH) $K_a = 6.3 \times 10^{-4}$

Phosphoric acid (H_3PO_4) $K_a = 7.2 \times 10^{-3}$

Oxalic Acid ($\text{HO}_2\text{CCO}_2\text{H}$) $K_a = 5.6 \times 10^{-2}$

Arsenic acid (H_3AsO_4) $K_a = 6.0 \times 10^{-3}$

Solution:

Order of decreasing acid strength: Oxalic acid > Phosphoric acid > Arsenic acid > Formic acid

Equilibrium Equations:

- Oxalic acid: $\text{HO}_2\text{CCO}_2\text{H}(aq) \rightleftharpoons \text{H}_{(aq)}^+ + \text{HO}_2\text{CCO}_2^-(aq)$
- Phosphoric acid: $\text{H}_3\text{PO}_4(aq) \rightleftharpoons \text{H}_{(aq)}^+ + \text{H}_2\text{PO}_4^-(aq)$
- Arsenic acid: $\text{H}_3\text{AsO}_4(aq) \rightleftharpoons \text{H}_{(aq)}^+ + \text{H}_2\text{AsO}_4^-(aq)$
- Formic acid: $\text{HCOOH}(aq) \rightleftharpoons \text{H}_{(aq)}^+ + \text{HCOO}^-(aq)$

Equilibrium Constants for Acid and Base Dissociation

The pH for solutions of strong acids and strong bases can be calculated simply by knowing the original concentration of acid or base. Consider a solution that is 0.010M HCl. HCl is a strong acid, so the acid molecules dissociate completely. At equilibrium, this solution of HCl will be 0.010 M in H^+ ions and 0.010 M in Cl^- ions. Plugging the value of the hydrogen ion concentration into the pH formula, we can determine that this solution has a pH of 2.

Consider a 0.0010 M NaOH solution. NaOH is a strong base, so this solution will be 0.0010 M in sodium ions and also in hydroxide ions. Since the solution is 1.0×10^{-3} M in hydroxide ions, it will be 1.0×10^{-11} M in hydrogen ions. Therefore, this solution will have a pH = 11.

A strong acid such as H_2SO_4 is only slightly more complicated. Suppose we wish to determine the pH of a 0.00010 M solution of H_2SO_4 .

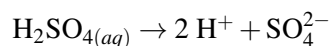

Since the original solution was 0.00010 M and sulfuric acid is a strong acid, then complete dissociation will produce a solution that contains $[\text{H}^+] = 0.00020$ M. Substituting this hydrogen ion concentration in the pH formula yields:

$$\text{pH} = -\log(2.0 \times 10^{-4}) = -(0.30 - 4) = -(-3.7) = 3.7$$

Let's now consider the process for finding the pH of weak acids and bases. In these cases, you need more information than you need for strong acids and bases. Not only do you need to know the concentration of the original acid or base solution, but you also must know the K_a or K_b . Suppose we wish to know the pH of a 1.0 M solution of ascorbic acid, $\text{H}_2\text{C}_6\text{H}_6\text{O}_6(aq)$, whose $K_a = 7.9 \times 10^{-5}$.

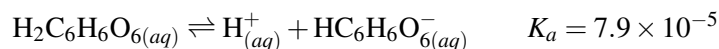

The K_a expression for this reaction would be written

$$K_a = \frac{[\text{H}^+][\text{HC}_6\text{H}_6\text{O}_6^-]}{[\text{H}_2\text{C}_6\text{H}_6\text{O}_6]}$$

To find the hydrogen ion concentration from this K_a expression and the original concentration of the acid, we need a little algebra. Let the molarity of the acid that has already dissociated be represented by x . In other words, the molarity of the hydrogen ions and ascorbate ions in solution will also be represented by x . The molarity of the undissociated acid must therefore be $1.0 - x$. We can now substitute these variables into the K_a expression and set it equal to the given K_a value.

$$K_a = \frac{(x)(x)}{(1.0-x)} = 7.9 \times 10^{-5}$$

When this equation is simplified, we find that it is a quadratic equation, which, of course, can be solved by the quadratic formula.

$$\begin{aligned} x^2 + (7.9 \times 10^{-5})x - (7.9 \times 10^{-5}) &= 0 \\ x &= 8.9 \times 10^{-3} \text{ M} \end{aligned}$$

However, there is a shortcut available to solve this problem that simplifies the math greatly. It involves significant figures and adding or subtracting extremely small numbers from large numbers. If you are working to 3 significant figures and you are required to subtract 0.00005 from 1.00, when you carry out the subtraction and round to 3 significant figures, you discover that you get the original number before you subtracted.

$$1.00 - 0.00005 = 0.99995, \text{ which to 3 significant figures is } 1.00.$$

In the problem we solved above about ascorbic acid, the K_a value is very small, 1.8×10^{-5} . This indicates that the amount of ascorbic acid that dissociates, represented by x , is tiny. When we assigned the variables in that problem, we see that the molarity of ascorbic acid remaining after dissociation is represented by $1.0 - x$. Since this x is very tiny, the result of this subtraction will still be 1.0 M. Therefore, the K_a expression from above,

$$K_a = \frac{(x)(x)}{(1.0-x)} = 7.9 \times 10^{-5}$$

can quite safely be written as

$$K_a = \frac{(x)(x)}{(1.0)} = 7.9 \times 10^{-5}$$

We are assuming x is so small that it will not alter the value of 1.0 when we subtract and then round to proper significant figures. This is a safe assumption when the value of the K_a is very small (less than 1×10^{-3}).

When we solve this second expression,

$$\begin{aligned} \frac{(x)(x)}{(1.0)} &= 7.9 \times 10^{-5} \\ x^2 &= 7.9 \times 10^{-5} \\ x &= 8.9 \times 10^{-3} \text{ M} \end{aligned}$$

We no longer need to use the quadratic formula, and note that the answer (when rounded to the proper number of significant figures) is exactly the same as when the expression was solved with the quadratic formula.

Let's go through another example using a hypothetical weak acid, 0.10 M HA , whose $K_a = 4.0 \times 10^{-7}$.

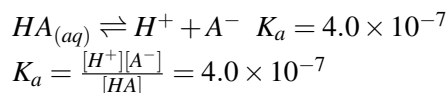

Let x represent the molarity of HA that dissociates, so $[H^+] = [A^-] = x$, and $[HA] = 0.10 - x$.

$$K_a = \frac{[x][x]}{[0.10-x]} = 4.0 \times 10^{-7}$$

Once again, since the K_a value is very small, the x subtracted in the denominator can be neglected. and the equation becomes

$$\begin{aligned} K_a &= \frac{[x][x]}{[0.10]} = 4.0 \times 10^{-7} \\ x^2 &= 4.0 \times 10^{-8} \\ x &= 2.0 \times 10^{-4} \text{ M} \end{aligned}$$

Therefore, the hydrogen ion concentration in this solution is 2.0×10^{-4} M. Substituting this value into the pH formula yields:

$$\text{pH} = -\log(2.0 \times 10^{-4}) = -(0.3 - 4) = -(-3.7) = 3.7$$

The same process is used for weak bases. There is one additional step when working with weak bases: once the hydroxide ion concentration is determined, you must then find the hydrogen ion concentration before substituting the value into the pH formula. K_b represents the equilibrium constant for the reduction between a weak base and water. Consider dimethylamine (a weak base used in making detergents). We will calculate the pH of a 1.0 M solution of this weak base.

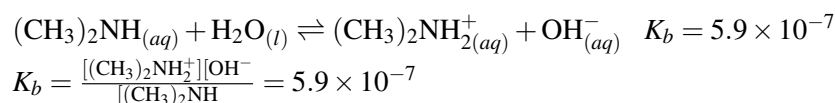

Allowing x to represent the molarity of $(\text{CH}_3)_2\text{NH}$ that dissociates results in $[(\text{CH}_3)_2\text{NH}_2^+] = x$ and $[\text{OH}^-] = x$. The molarity of undissociated $(\text{CH}_3)_2\text{NH}$ will be $1.0 - x$.

Substituting the variables into the K_b expression yields

$$K_b = \frac{[x][x]}{[1.0-x]} = 5.9 \times 10^{-7}$$

and neglecting the x in the denominator because it is beyond the significant figures of the problem yields

$$K_b = \frac{[x][x]}{[1.0]} = 5.9 \times 10^{-7}$$

Therefore,

$$\begin{aligned}x^2 &= 5.9 \times 10^{-7} \\x &= 7.7 \times 10^{-4} \text{ M}\end{aligned}$$

Now that we know the hydroxide ion concentration in the solution, we calculate the hydrogen ion concentration by dividing the $[\text{OH}^-]$ into the K_w . This will yield $[\text{H}^+] = 1.3 \times 10^{-11}$ M. The final step is to plug the hydrogen ion concentration into the pH formula.

$$\text{pH} = -\log(1.3 \times 10^{-11}) = 10.9$$

Example:

Acetic acid is mixed with water to form a 0.10 mol/L $\text{HC}_2\text{H}_3\text{O}_2(\text{aq})$ solution at 25°C. If the equilibrium concentrations of $\text{H}_3\text{O}^+(\text{aq})$ and $\text{C}_2\text{H}_3\text{O}_2^-(\text{aq})$ are both 1.34×10^{-3} mol/L and the equilibrium concentration of $\text{HC}_2\text{H}_3\text{O}_2(\text{aq})$ is 0.0999 mol/L, determine the K_a and the pH of the solution at equilibrium.

Solution:

$$\begin{aligned}\text{HC}_2\text{H}_3\text{O}_2(\text{aq}) &\rightleftharpoons \text{H}^+(\text{aq}) + \text{C}_2\text{H}_3\text{O}_2^-(\text{aq}) \\K_a &= \frac{[\text{H}^+][\text{C}_2\text{H}_3\text{O}_2^-]}{[\text{HC}_2\text{H}_3\text{O}_2]} = \frac{(1.34 \times 10^{-3})(1.34 \times 10^{-3})}{0.0999} = 1.80 \times 10^{-5} \\ \text{pH} &= -\log[\text{H}^+] = -\log(1.34 \times 10^{-3}) = 2.87\end{aligned}$$

This video shows an example of how to plug values into the K_a for a weak acid to find $[\text{H}^+]$ and pH (5c): <http://www.youtube.com/watch?v=MOv7Z16FMK0> (3:26).

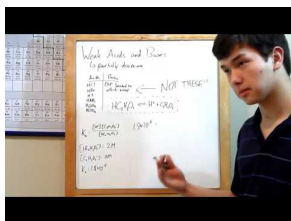

MEDIA

Click image to the left for more content.

Lesson Summary

- Strong acids and bases undergo 100% dissociation in water.
- Weak acids undergo less than 100% dissociation in water.
- It is safe to assume that an acid is weak unless it is one of the six strong acids listed in the chapter.
- K_a represents the equilibrium constant for the dissociation of a weak acid.
- K_b represents the equilibrium constant for the dissociation of a weak base.
- Equilibrium calculations are the same for weak acids and bases as they were for all other equilibrium reactions.

Further Reading / Supplemental Links

Visit the link below for more information about the strengths of acids and bases.

- <http://chemistry.about.com/od/acidsbases/a/strengthacids.htm>

Review Questions

- What makes weak acids and bases a special case for equilibrium reactions?
- What do the constants K_a and K_b represent?
- Oxalic acid is a weak acid. Its ionization reaction is represented as: $\text{H}_2\text{C}_2\text{O}_4(aq) + \text{H}_2\text{O}(l) \rightleftharpoons \text{H}_3\text{O}^+(aq) + \text{HC}_2\text{O}_4^-(aq)$. Which of the following best represents the acid ionization constant expression, K_a ?
 - $K_a = \frac{[\text{H}_3\text{O}^+][\text{HC}_2\text{O}_4^-]}{[\text{H}_2\text{C}_2\text{O}_4][\text{H}_2\text{O}]}$
 - $K_a = \frac{[\text{H}_2\text{C}_2\text{O}_4][\text{H}_2\text{O}]}{[\text{H}_3\text{O}^+][\text{HC}_2\text{O}_4^-]}$
 - $K_a = \frac{[\text{H}_3\text{O}^+][\text{HC}_2\text{O}_4^-]}{[\text{H}_2\text{C}_2\text{O}_4]}$
 - $K_a = \frac{[\text{H}_2\text{C}_2\text{O}_4]}{[\text{H}_3\text{O}^+][\text{HC}_2\text{O}_4^-]}$
- Choose the weakest acid from the list below.
 - $\text{HNO}_2(aq); K_a = 5.6 \times 10^{-3}$
 - $\text{HF}(aq); K_a = 6.6 \times 10^{-4}$
 - $\text{H}_3\text{PO}_4(aq); K_a = 6.9 \times 10^{-3}$
 - $\text{HCOOH}(aq); K_a = 1.8 \times 10^{-4}$
- Choose the reaction that would have an equilibrium constant represented by K_b .
 - $\text{H}_2\text{PO}_4^-(aq) + \text{H}_2\text{O}(l) \rightleftharpoons \text{HPO}_4^{2-}(aq) + \text{H}_3\text{O}^+(aq)$
 - $\text{NH}_4^+(aq) + \text{H}_2\text{O}(l) \rightleftharpoons \text{NH}_3(aq) + \text{H}_3\text{O}^+(aq)$
 - $\text{NH}_4^-(aq) + \text{OH}^-(aq) \rightleftharpoons \text{NH}_3(aq) + \text{H}_2\text{O}(l)$
 - $\text{F}^-(aq) + \text{H}_2\text{O}(l) \rightleftharpoons \text{HF}(aq) + \text{OH}^-(aq)$
- A 0.150 mol/L solution of a weak acid having the general formula HA is 15.0% ionized in aqueous solution. Which expression best represents the calculation of the acid ionization constant K_a for this acid?
 - $K_a = \frac{(0.150)(0.150)}{(0.150)}$
 - $K_a = \frac{(0.0225)(0.0225)}{(0.128)}$
 - Not enough information is given.
- Put the following bases in order of increasing base strength. Write equilibrium reactions for each.
 - ethanolamine ($\text{HOCH}_2\text{CH}_2\text{NH}_2$), $K_b = 3.2 \times 10^{-5}$
 - piperidine ($\text{C}_5\text{H}_{10}\text{NH}$), $K_b = 1.3 \times 10^{-3}$
 - triethylamine ($(\text{CH}_3\text{CH}_2)_3\text{N}$), $K_b = 5.2 \times 10^{-4}$
 - ethylenediamine ($\text{H}_2\text{NCH}_2\text{CH}_2\text{NH}_2$), $K_b = 8.5 \times 10^{-5}$

20.5 Brønsted-Lowry Acids and Bases

Lesson Objectives

The student will:

- define Brønsted-Lowry acids and bases.
- identify Brønsted-Lowry acids and bases in chemical equations.
- define conjugate acids and bases.
- write the formula for the conjugate acid of any base and for the conjugate base of any acid.
- identify conjugate acids and bases in equations.
- given the strengths of acids and bases, identify the strength the conjugate acids and bases.

Vocabulary

- amphoteric
- Brønsted-Lowry acid
- Brønsted-Lowry base
- conjugate acid
- conjugate base

Introduction

Arrhenius provided chemistry with the first definition of acids and bases, but like a lot of scientific ideas, these definitions have been refined over time. Two chemists, named Brønsted and Lowry, derived a more generalized definition for acids and bases that we use in conjunction with the Arrhenius theory. The Brønsted-Lowry theory is the focus of this lesson. As the Brønsted-Lowry definition unfolded, the number of acids and bases that were able to fit into each category increased.

Brønsted-Lowry Acids and Bases

Arrhenius made great in-roads into the understanding of acids and bases and how they behaved in chemical reactions. Brønsted and Lowry slightly altered the Arrhenius definition and greatly increased the number of compounds that qualify as bases. A **Brønsted-Lowry acid** is a substance that is a proton donor, and a **Brønsted-Lowry base** is a proton acceptor. Look at the equation below in which hydrochloric acid is reacting with water:

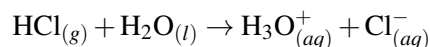

The Brønsted-Lowry concept of acids and bases states that the acid donates a proton and the base accepts a proton. Therefore, HCl acts as the acid and donates an H^+ ion to H_2O to form Cl^- . The H_2O acts as the base and accepts an H^+ ion from HCl to form H_3O^+ . Look at the equation below for another example of Brønsted-Lowry acid and base:

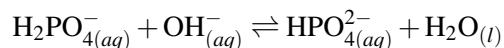

The equation shows H_2PO_4^- donating a proton to OH^- and forming HPO_4^{2-} , while OH^- is accepting the proton to form H_2O . Thus, H_2PO_4^- is acting as the acid and OH^- is acting as the base.

Example:

Identify the Brønsted-Lowry acids and bases from each of the following equations:

- $\text{HC}_2\text{H}_3\text{O}_2{}_{(aq)} \rightleftharpoons \text{C}_2\text{H}_3\text{O}_2^-{}_{(aq)} + \text{H}_3\text{O}^+{}_{(aq)}$
- $\text{HCN}_{(aq)} + \text{H}_2\text{O}_{(l)} \rightleftharpoons \text{CN}^-{}_{(aq)} + \text{H}_2\text{O}^+{}_{(aq)}$

Solution:

- $\text{HC}_2\text{H}_3\text{O}_2$ is acting as the acid and H_2O is acting as the base.
- HCN is acting as the acid and H_2O is acting as the base.

If you think about the definition of an Arrhenius acid, it includes substances such as HCl, HNO_3 , $\text{HC}_2\text{H}_3\text{O}_2$ - in essence all substances that contain H^+ ions. This is because according to Arrhenius, the acid dissociates in water to produce H^+ ions. This definition limits what can fit under the umbrella of the definition of acid. The Brønsted-Lowry definition of the acid is broader in that it defines the acid as a proton donor. With this broader definition there is the ability to include more compounds in the category of acid.

It needs to be pointed out that if a substance is an acid in the Arrhenius definition, it will be an acid in the Brønsted-Lowry definition. The same relationship holds for bases. The reverse, however, is not true. Consider the equation below. The hydroxide ion, OH^- , is both an Arrhenius base and a Brønsted-Lowry base. In other words, the Brønsted-Lowry definition can be viewed as an extension to the Arrhenius definition rather than a replacement of it.

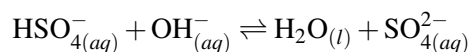

With the Arrhenius theory, water was a necessary part of the equation. Arrhenius said that an acid must produce H^+ ions in a water solution. Therefore, the following equation would be representative of an Arrhenius acid:

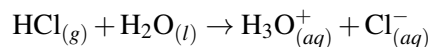

Now consider the following reaction:

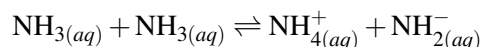

The first NH_3 molecule is accepting a proton to form NH_4^+ and is therefore a Brønsted-Lowry base, the second NH_3 molecule is donating a proton to form NH_2^- and is therefore a Brønsted-Lowry acid. Ammonia molecules, however, do not donate hydrogen ions in water, so they do not qualify as Arrhenius acids. The Brønsted-Lowry theory has provided a broader theory for acid-base chemistry.

It should be noted that NH_3 is an example of an amphoteric species. **Amphoteric** species are those that can act as either an acid or a base, depending on the situation. That is, in some circumstances, they donate a proton, and in other circumstances, they accept a proton. Water is another example of an amphoteric species.

Acid-Base Conjugate Pairs

There is one more aspect of the Brønsted-Lowry theory that was a significant breakthrough to acid-base chemistry. Brønsted and Lowry said that in acid-base reactions, there are actually pairs of acids and bases in the reaction itself. According to Brønsted-Lowry, for every acid there is a conjugate base associated with that acid. The **conjugate base** is the result of the acid losing (or donating) a proton. Therefore, if you look at the figure below, you can see the acid on the left and the conjugate base on the right.

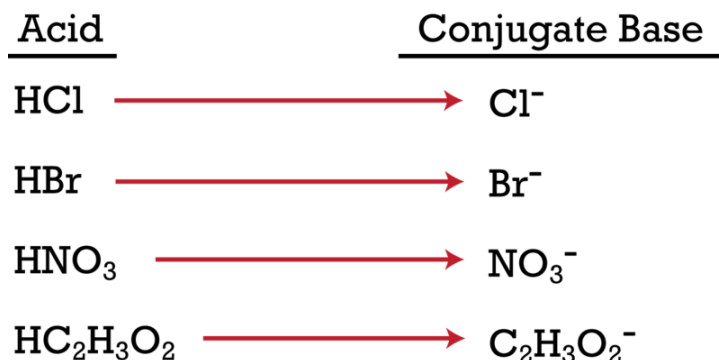

Notice that the difference between the acid and its conjugate base is simply a proton. Similarly, for every base in the acid-base reaction, there must be a corresponding conjugate acid. The **conjugate acid** is the result of the base gaining (or accepting) the proton. Look at the figure below to see the difference between the base and the corresponding conjugate acid.

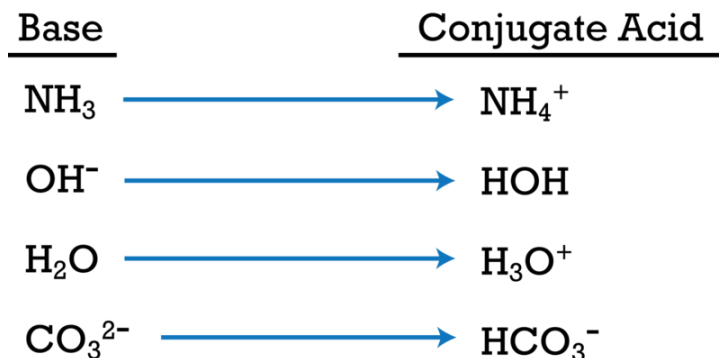

Now that we know what conjugate acids and bases are, let's try to identify them in acid-base reactions. Consider the reaction between acetic acid and water shown below:

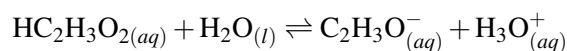

Step 1: Identify the acid and base on the reactants side.

HC₂H₃O₂ is the acid and H₂O is the base.

Step 2: Identify the conjugate acid and base on the products side.

Look at the product side to see what product has gained a proton (this is the conjugate acid) and which product has lost a proton (this is the conjugate base).

$\text{C}_2\text{H}_3\text{O}_2^-$ is the conjugate base of $\text{HC}_2\text{H}_3\text{O}_2$, and H_3O^+ is the conjugate acid of H_2O .

As a result, the conjugate acid/base pairs are $\text{HC}_2\text{H}_3\text{O}_2 / \text{C}_2\text{H}_3\text{O}_2^-$ and $\text{H}_3\text{O}^+ / \text{H}_2\text{O}$.

Let's consider another example. Identify the conjugate acid-base pairs in the following equation.

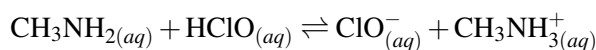

Step 1: Identify the acid and base on the reactants side.

CH_3NH_2 is the base and HClO is the acid.

Step 2: Identify the conjugate acid and base on the products side.

ClO^- is the conjugate base and CH_3NH_3^+ is the conjugate acid.

Hence, the conjugate acid/base pairs are $\text{CH}_3\text{NH}_2 / \text{CH}_3\text{NH}_3^+$ and $\text{HClO} / \text{ClO}^-$.

Example:

Identify the conjugate acid-base conjugate pairs in each of the following equations:

- $\text{NH}_3(aq) + \text{HCN}(aq) \rightleftharpoons \text{NH}_4^+(aq) + \text{CN}^-(aq)$
- $\text{CO}_3^{2-}(aq) + \text{H}_2\text{O}(l) \rightleftharpoons \text{HCO}_3^-(aq) + \text{OH}^-(aq)$

Solution:

- $\text{NH}_3 / \text{NH}_4^+$ and HCN / CN^-
- $\text{CO}_3^{2-} / \text{HCO}_3^-$ and $\text{H}_2\text{O} / \text{OH}^-$

The Strength of Conjugate Acids and Bases

As a general rule, the stronger an acid is, the weaker its conjugate base will be. The same is true for the relationship between bases and their conjugate acids. Overall:

- Strong acid \rightarrow Very weak conjugate base
- Weak acid \rightarrow Weak conjugate base
- Weak base \rightarrow Weak conjugate acid
- Strong base \rightarrow Very weak conjugate acid

Since acid strength and conjugate base strength are inversely related, you might think that strong acids would have weak conjugate bases, while weak acids would have strong conjugate bases. Although this is true in a relative sense, it does not match up to the way we have been defining “strong” acids and bases so far. This can often be confusing for students just beginning their study of chemistry.

Let's re-examine how we have defined strong and weak acids and bases. This can be illustrated most clearly by looking at some representative examples. Consider the following equilibria:

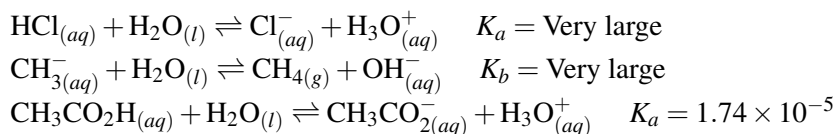

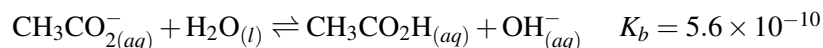

HCl is an example of a strong acid because it completely dissociates in water. Another way to say this is that HCl is a very strong acid *compared to* H_3O^+ , because when Cl^- (its conjugate base) and water are competing for a proton, water wins nearly every time. Cl^- is such a weak base that, when considered outside the context of an acid/base reaction, you would not even consider it a base. For example, a solution of NaCl contains Cl^- ions, but you would never say that the solution is basic.

On the opposite side of things, we can consider the reaction of CH_3^- with water. (The strong bases you have learned about so far all contain OH^- , but using one of those bases as an example makes the following explanation a little confusing.) CH_3^- is one of the strongest bases known, and it is at least 10^{25} times stronger than OH^- . In the competition for control of a proton, CH_3^- beats OH^- by a landslide. On the other side of the equation, we see that its conjugate “acid” is methane, CH_4 . Again, outside this context, you would never consider methane to be an acid, because almost nothing is strong enough to remove one of its protons. Thus, CH_3^- is an extremely strong base *compared to* OH^- . Notice that the species we are using for comparison changes when we are talking about acids versus bases.

Now let’s look at the dissociation of acetic acid. You can see by the equilibrium constant that the reactants should be favored. This means that when the base and the conjugate base (in this case, acetate ions and water molecules) are competing for a proton, acetate wins most of the time. *Compared to* H_3O^+ , acetic acid is a much weaker acid. This is equivalent to the statement that acetic acid will not dissociate much in water, which is how we have previously defined weak acids.

However, acetate ion is *not* considered a strong base. Look at the final equation above. Once again, the equilibrium constant is small, so reactants will be favored. How can this be? Why would acetic acid be favored in the third reaction, while acetate is favored in the fourth one? The reason is that we are changing the base that the acetate ion is competing with. In the third equation, acetate is competing with water. *Compared to water*, acetate is a good base. However, we generally define “strong” and “weak” bases by comparing them to OH^- , not H_2O . *Compared to* OH^- , acetate is a weak base.

Thus, we can see why a weak acid can still produce a weak conjugate base, and vice versa. It is important to remember that “acidic” and “basic” are relative terms. It is very useful to have standard benchmarks (H_3O^+ and OH^-) to use for comparison, but figuring out what is “strong” and what is “weak” can be confusing if you don’t realize that the reference point we use when talking about acids is different than the one we use when talking about bases.

Lesson Summary

- The Brønsted-Lowry concept of acids and bases states that the acid donates a proton and the base accepts a proton.
- A conjugate acid is a substance that results when a base gains (or accepts) a proton.
- A conjugate base is a substance that results when an acid loses (or donates) a proton.
- Strong acids result in very weak conjugate bases when they lose a proton, and weak acids result in very strong conjugate bases when they lose a proton.
- Strong bases result in very weak conjugate acids when they gain a proton, and weak bases result in very strong conjugate acids when they gain a proton.

Further Reading / Supplemental Links

The *learner.org* website allows users to view the Annenberg series of chemistry videos. You are required to register before you can watch the videos, but there is no charge to register. The video called “The Proton in Chemistry” explains pH and how it is measured, as well as the important role of acids and bases.

- http://www.learner.org/vod/vod_window.html?pid=808

Review Questions

1. What improvements did Brønsted-Lowry make over the Arrhenius definition for acids-bases?
2. What is the Brønsted-Lowry definition of an acid?
 - a. A substance that donates protons.
 - b. A substance that accepts protons.
 - c. A substance that dissolves in water to form OH^- ions.
 - d. A substance that dissolves in water to form H^+ ions.
3. If H_3O^+ is an acid according to the Brønsted-Lowry theory, what is the conjugate base of this acid?
 - a. $\text{H}_4\text{O}^{2+}(\text{aq})$
 - b. $\text{H}^+(\text{aq})$
 - c. $\text{H}_2\text{O}(\text{l})$
 - d. $\text{OH}^-(\text{aq})$
4. What is the conjugate base of H_2PO_4^- ?
 - a. $\text{H}_3\text{O}^+(\text{aq})$
 - b. $\text{H}_3\text{PO}_4(\text{aq})$
 - c. $\text{HPO}_4^{2-}(\text{aq})$
 - d. $\text{PO}_4^{3-}(\text{aq})$
5. In the following reactions, which are the Brønsted-Lowry acids? $\text{H}_3\text{PO}_4(\text{aq}) + \text{H}_2\text{O}(\text{l}) \rightleftharpoons \text{H}_3\text{O}^+(\text{aq}) + \text{H}_2\text{PO}_4^-(\text{aq})$,
 $\text{H}_2\text{PO}_4^-(\text{aq}) + \text{H}_2\text{O}(\text{l}) \rightleftharpoons \text{H}_3\text{O}^+(\text{aq}) + \text{HPO}_4^{2-}(\text{aq})$
 - a. H_2PO_4^- , H_2O , HPO_4^{2-}
 - b. H_3PO_4 , H_2O , H_2PO_4^-
 - c. H_3O^+ , H_2O , HPO_4^{2-}
 - d. H_3PO_4 , H_3O^+ , H_2PO_4^-
6. Label the conjugate acid-base pairs in each reaction.
 - a. $\text{HCO}_3^- + \text{H}_2\text{O} \rightleftharpoons \text{H}_2\text{CO}_3 + \text{OH}^-$
 - b. $\text{H}_2\text{PO}_4^- + \text{H}_2\text{O} \rightleftharpoons \text{H}_3\text{O}^+ + \text{HPO}_4^{2-}$
 - c. $\text{CN}^- + \text{H}_2\text{O} \rightleftharpoons \text{HCN} + \text{OH}^-$
 - d. $\text{HF}(\text{aq}) + \text{H}_2\text{O}(\text{l}) \rightleftharpoons \text{H}_3\text{O}^+(\text{aq}) + \text{F}^-(\text{aq})$
7. Complete the following reactions. When done, label the conjugate acid/base pairs.
 - a. $\text{BrO}_3^- + \text{H}_2\text{O} \rightleftharpoons$
 - b. $\text{HNO}_3 + \text{H}_2\text{O} \rightarrow$
 - c. $\text{HSO}_4^- + \text{C}_2\text{O}_4^{2-} \rightleftharpoons$
8. For the reactions in question 7, which are the weak conjugate bases and which are the strong conjugate bases?

20.6 Lewis Acids and Bases

Lesson Objectives

The student will:

- define a Lewis acid and a Lewis base.
- identify Lewis acids and bases in equations.

Vocabulary

- Lewis acid
- Lewis base

Introduction

In the early 1930s, Gilbert Lewis saw the need for an even more general definition for acids and bases. Using the work of Brønsted and Lowry, he saw that in some cases, the acids may not have protons to donate but may still be able to donate an atom to the electron pair of a base. Most chemists today use the Brønsted-Lowry definitions of acids-bases, except for specialized situations that require the Lewis definitions.

Lewis Acids

Lewis defined an acid as a substance that accepts a pair of electrons from another substance. Therefore, **Lewis acids** must have room in their structure to accept a pair of electrons. Remember that each central atom can hold eight valence electrons. What this means is that if the atom has six or less valence electrons, then it can accept one more pair. Look at the structures below. Notice how, in each case, there is room to accept a pair of electrons.

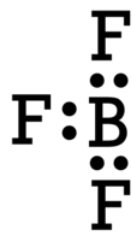

The BF₃ molecule can hold 8 electrons surrounding the boron atom, but in this case has only 6 electrons around the boron. Therefore, this molecule can take on two electrons and that makes it a Lewis acid.



This hydrogen ion can hold 2 electrons around the hydrogen atom, but in this case has zero electrons around the hydrogen. Therefore, this ion can take on two electrons and that makes it a Lewis acid.

The Lewis acid will accept the electron pair in order to form a bond. The bond that forms between the two atoms will be covalent. Remember that covalent bonds are formed when electrons are shared between two atoms.

Lewis Bases

A **Lewis base** is an electron-pair donor. These electrons are not transferred, but rather shared covalently to complete the acid/base reaction. If we look at the example of bases in the figure below, we can see that each of them has a lone pair of electrons available to donate.

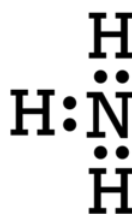

This ammonia molecule has four pairs of electrons around its central atom and only three of the pairs are shared. Therefore, this molecule has another pair of electrons that it can share and that makes it a Lewis base.



This hydroxide ion has four pairs of electrons around its central atom and only one of the pairs is shared. Therefore, this ion has unshared pairs of electrons available to share and that makes it a Lewis base.

This video contains textbook definitions of Arrhenius, Bronsted, and Lewis acids and bases (**5b**, **5e**): <http://www.youtube.com/watch?v=jLcoIRUiz20> (3:14).



MEDIA

Click image to the left for more content.

Lesson Summary

- Lewis defined an acid as a substance that accepts a pair of electrons from a substance to form a bond.
- Lewis defined a base as a substance that donates a pair of electrons to a substance to form a bond.

Review Questions

1. How do the Lewis definitions of acids and bases compare to the Brønsted-Lowry definitions of acids and bases?
2. In the following reversible reaction, which of the reactants is acting as a Lewis base: $\text{Cd}^{2+}_{(aq)} + 4 \text{I}^{-}_{(aq)} \rightleftharpoons \text{CdI}_4^{2-}_{(aq)}$?
 - a. Cd^{2+}
 - b. I^{-}
 - c. CdI_4^{2-}
 - d. None of the above, this is not an acid-base reaction.
3. Which of the following statements is false?
 - a. NH_3 is a Lewis base.
 - b. $\text{B}(\text{OH})_3$ is a Lewis acid.
 - c. CO_2 is a Lewis base.
 - d. Ag^{+} Is a Lewis acid.
4. Which of the following statements is true?
 - a. NH_3 is a Lewis base.
 - b. $\text{B}(\text{OH})_3$ is a Lewis acid.
 - c. CO_2 is a Lewis base.
 - d. Ag^{+} Is a Lewis acid.
5. Classify each of the following as a Lewis acid or base.
 - a. H_2O
 - b. BF_3
 - c. S^{2-}
 - d. Cu^{2+}
 - e. O^{2-}
6. Write the balanced chemical equation between SO_3^{2-} and H_2O and label the Lewis acids and bases.
7. Identify the Lewis acid and Lewis base in the following reaction: $\text{Cu}^{2+}_{(aq)} + 6 \text{H}_2\text{O}_{(l)} \rightarrow \text{Cu}(\text{H}_2\text{O})_6^{2+}_{(aq)}$.

All images, unless otherwise stated, are created by the CK-12 Foundation and are under the Creative Commons license CC-BY-NC-SA.

CHAPTER 21**Neutralization****Chapter Outline**

21.1 NEUTRALIZATION**21.2 TITRATION****21.3 BUFFERS****21.4 REFERENCES**

21.1 Neutralization

Lesson Objectives

The student will:

- explain what is meant by a neutralization reaction and give an example of one.
- write a balanced equation for the reaction that occurs when an acid reacts with a base.
- describe the formation of a salt in terms of the Arrhenius definitions of acids and bases.
- predict the salt that will be produced from the neutralization reaction between a given acid and base.
- identify acidic, basic, and neutral salts from a neutralization reaction.

Vocabulary

- acidic salt
- basic salt
- neutral salt
- neutralization

Introduction

Neutralization is a reaction between an acid and a base that produces water and a salt. The general reaction is shown below:

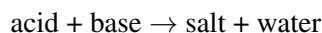

After reviewing the concept of ionic compounds, we will examine neutralization reactions and look at the different types of salts that can be formed from acids and bases as they react with one another.

Neutralization Reactions

Acids are a combination of a hydrogen cation and a nonmetal anion. Examples include HCl, HNO₃, and HC₂H₃O₂. Many bases are a combination of metal cations and nonmetal anions. Examples include NaOH, KOH, and Mg(OH)₂. According to the Arrhenius definitions of acids and bases, the acid will contribute an H⁺ ion that will react to neutralize the OH⁻ ion contributed by the base, producing neutral water molecules.

All acid-base reactions produce salts. The anion from the acid will combine with the cation from the base to form the ionic salt. Examples are shown below.

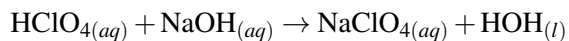

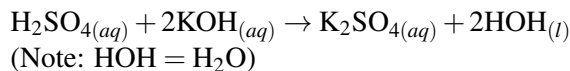

No matter what the acid or the base may be, the products of this type of reaction will always be a salt and water. Aside from the fact that the H⁺ ion will neutralize the OH⁻ ion to form water, we also know that these reactions are double displacement reactions, because they consist of cations exchanging anions.

We can write this as a total ionic equation:

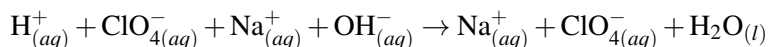

However, since Na⁺ and ClO₄⁻ are spectator ions, the net ionic equation is:

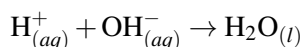

This is the net ionic equation for all neutralization reactions.

Salt Hydrolysis

When a salt is dissolved in water, it is possible for the solution to be neutral, acidic, or basic. If a solution is to be acidic, it must contain more hydrogen ions than hydroxide ions. For the solution to be basic, it must contain more hydroxide ions than hydrogen ions. Consider the solution produced when the salt KBr dissolves in water. There will be four ions present in the solution.



When potassium ions in the solution come into contact with hydroxide ions, the KOH ion pair could potentially form. However, since KOH is a strong base, it would immediately dissociate back into ions. Similarly, if the bromide ions come into contact with hydrogen ions, the molecule formed would be HBr, a strong acid, so they would immediately dissociate back into ions. Thus, having potassium and bromide ions in a water solution would not cause a reaction.

Now consider the solution produced when the salt NH₄Cl is dissolved in water. There will be four ions present in the solution.

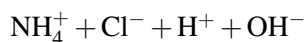

When hydrogen ions come into contact with chloride ions, if they join together, the resultant molecule would be HCl, which is a strong acid. Therefore, the HCl would immediately dissociate back into the ions. When NH₄⁺ ions come into contact with OH⁻ ions, however, the resultant molecule would be NH₄OH, which is a weak base and does not dissociate very much. Therefore, when ammonium chloride is dissolved in water, a reaction occurs.

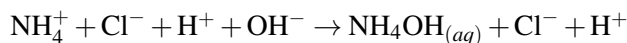

The ammonium hydroxide dissociates very little, so we would have mostly un-dissociated ammonium hydroxide molecules in solution with hydrogen and chloride ions. The hydrogen ions in this final solution would cause the solution to be acidic. Thus, dissolving ammonium chloride in water produces an acidic solution.

By a similar process, dissolving sodium acetate, NaC₂H₃O₂, in water will produce a basic solution. When the sodium acetate is dissolved in water, four ions will be present in the solution.

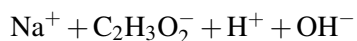

If sodium ions contact hydroxide ions, the substance formed would be a strong base which would immediately dissociate. If hydrogen ions contact acetate ions, however, the molecule formed would be acetic acid, which is a weak acid and the ions would NOT dissociate. Therefore, when sodium acetate is dissolved in water, a reaction will occur as shown below.

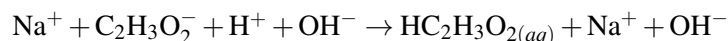

The resultant solution has excess of hydroxide ions, so it is basic. Dissolving sodium acetate in water produces a basic solution.

Neutral, Acidic, and Basic Salts

Table 21.1 shows all of the strong acids and bases that we have encountered so far. You can assume that any other acids and bases we will look at are weak.

TABLE 21.1: Strong Acids and Bases

Strong Acid	Formula	Strong Base	Formula
Hydrochloric Acid	HCl	Lithium Hydroxide	LiOH
Hydrobromic Acid	HBr	Sodium Hydroxide	NaOH
Hydroiodic Acid	HI	Potassium Hydroxide	KOH
Nitric Acid	HNO ₃	Rubidium Hydroxide	RbOH
Perchloric Acid	HClO ₄	Cesium Hydroxide	CsOH
Sulfuric Acid	H ₂ SO ₄	Calcium Hydroxide	Ca(OH) ₂
		Strontium Hydroxide	Sr(OH) ₂
		Barium Hydroxide	Ba(OH) ₂

The information in the table helps us to determine what type of salt is formed in an acid-base reaction. For example, a reaction between a strong acid and a strong base will form a **neutral salt**. It is like a power struggle between the acid and the base. Since both are strong, neither overpower the other, so the salt ends up being neutral. If, however, we have a reaction between a weak acid and a strong base, the result would be a **basic salt**.

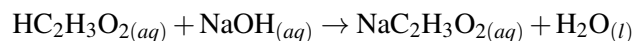

Acetic acid is a weak acid and sodium hydroxide is a strong base. Therefore, the salt formed, sodium acetate, is a basic salt.

When the basic salt is dissolved in water, a reaction takes place in which extra hydroxide ions, OH⁻, are produced from the salt and the water molecules. A similar situation will occur when we have a strong acid reacting with a weak base. When a strong acid reacts with a weak base, an **acidic salt** is formed.

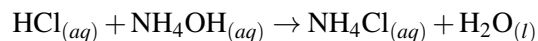

Hydrochloric acid is a strong acid and ammonium hydroxide is a weak base. Therefore, the salt formed, ammonium chloride, is an acidic salt. The salt will react with water molecules to produce hydrogen ions, H⁺, so it is referred to as an acidic salt.

Example:

Complete the following neutralization reactions and identify the type of salt produced.

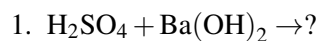

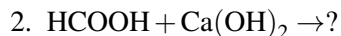

Solution:

1. $\text{H}_2\text{SO}_4 + \text{Ba}(\text{OH})_2 \rightarrow \text{BaSO}_4 + 2 \text{H}_2\text{O}$; A strong acid reacts with a strong base and produces a neutral salt.
2. $2 \text{HCOOH} + \text{Ca}(\text{OH})_2 \rightarrow \text{Ca}(\text{HCOO})_2 + 2 \text{H}_2\text{O}$; A weak acid reacts with a strong base and produces a basic salt.

By determining which acid and base were used to form the salt, you can figure out if the salt is acidic, basic, or neutral. For example, let's say you are looking at calcium nitrate, $\text{Ca}(\text{NO}_3)_2$. Remember that there is a double displacement reaction that forms the salt, so we can write out the reaction:

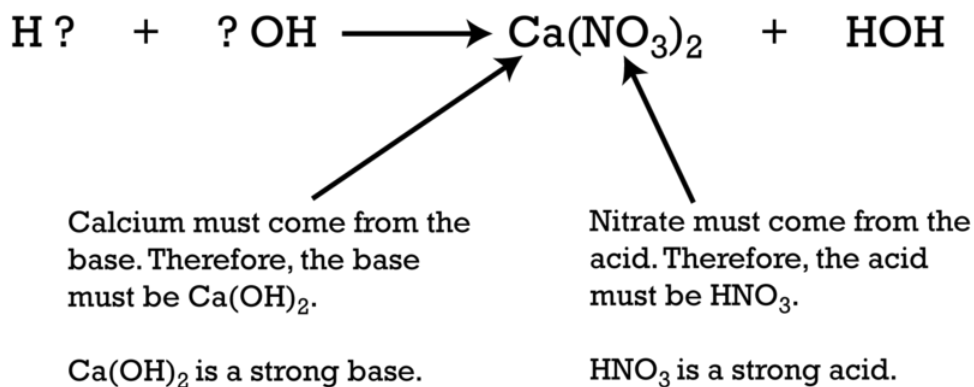

Therefore, the neutralization reaction would have been:

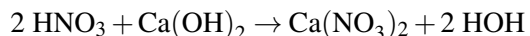

This salt would have been produced from a strong acid-strong base reaction, so it is neutral.

Let's try another. Consider the salt copper(II) chloride (CuCl_2).

The copper would have come from the base, $\text{Cu}(\text{OH})_2$, which is a weak base. The chloride would have come from the acid, HCl , which is a strong acid.

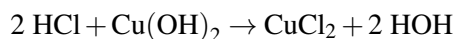

The reaction is a strong acid weak base reaction, so the salt should be acidic.

This video is an overview of endothermic and exothermic reactions and includes a demonstration of an exothermic reaction (7b): <http://www.youtube.com/watch?v=sAyPDTQHEE> (2:31).



MEDIA

Click image to the left for more content.

Lesson Summary

- A neutralization reaction between an acid and a base will produce a salt and water.
- In a neutralization reaction, the acid will produce H^+ ions that react to neutralize the OH^- ions produced by the base, forming neutral water. The other product will be an ionic salt.
- A strong acid + a strong base in an acid/base neutralization reaction will form a neutral salt.
- A strong acid + a weak base in an acid/base neutralization reaction will form an acidic salt.
- A weak acid + a strong base in an acid/base neutralization reaction will form a basic salt.

Further Reading / Supplemental Links

- The following link shows a video of a neutralization reaction.
 - http://www.youtube.com/watch?v=_P5hGzA6Vb0

Review Questions

1. How do an acid and a base fit the definition of an ionic compound? Use examples in your answer.
2. Explain neutralization reactions in terms of Arrhenius theory. Use an example in your answer.
3. Which salt will form a basic solution when dissolved in water?
 - a. KNO_3
 - b. CaCl_2
 - c. NaClO_4
 - d. NaNO_2
4. Which salt will form an acidic solution when dissolved in water?
 - a. copper(II) sulfate
 - b. sodium acetate
 - c. potassium chloride
 - d. sodium cyanide
5. Milk of magnesia is a common over-the-counter antacid that has magnesium hydroxide as its main ingredient. It is used by the public to relieve acid indigestion. Acid indigestion is caused by excess stomach acid being present. Write the balanced chemical equation for the reaction between milk of magnesia and hydrochloric acid. What type of reaction is this? What type of salt is formed?
6. Complete the following neutralization reactions and identify the type of salt produced.
 - a. $\text{H}_2\text{SO}_4(aq) + \text{NaOH}(aq) \rightarrow$
 - b. $\text{HNO}_3(aq) + \text{NH}_4\text{OH}(aq) \rightarrow$
 - c. $\text{HF}(aq) + \text{NH}_4\text{OH}(aq) \rightarrow$
 - d. $\text{CH}_3\text{COOH}(aq) + \text{KOH}(aq) \rightarrow$
 - e. $\text{HCl}(aq) + \text{KOH}(aq) \rightarrow$

21.2 Titration

Lesson Objectives

The student will:

- explain what an acid/base indicator is.
- explain how acid-base indicators work.
- explain the difference between natural and synthetic indicators.
- explain how indicators are used in the lab.
- explain what a titration is.
- describe how titrations can be used to determine the concentration of an acid or a base in solution.
- explain the difference between the equivalence point and the end point.
- define a standard solution in terms of acid-base titrations.
- calculate the concentration of an acid or base solution using a standard solution.
- calculate the concentration of unknown acid or base when given the concentration of the other and the volume needed to reach the equivalence point in a titration.

Vocabulary

- endpoint
- equivalence point
- natural indicator
- standard solution
- synthetic indicator
- titrant
- titration
- titration curve

Introduction

The typical laboratory procedure for determining the concentration of acid and/or base in a solution is to complete a titration. There are three main types of titration experiments. As we go through this lesson, we will take apply the knowledge we have obtained about acids and bases, chemical reactions, and molarity calculations to the concept of titrations.

Indicators

Recall from the chapter on “Acids-Bases” that an indicator is a substance that changes color at a specific pH and is used to indicate the pH of the solution. One example of an indicator is litmus paper. Litmus paper is paper that has been dipped in a substance that will undergo a color change when it is exposed to either an acid or a base. If red litmus paper turns blue, the solution is basic ($\text{pH} > 7$), and if blue litmus turns red the solution is acidic ($\text{pH} < 7$).

A **natural indicator** is an indicator that is a naturally occurring substance. For example, the juice from red cabbage can be used to prepare an indicator paper. It contains the chemical anthocyanin, which is the active ingredient in the indicator. Red beets, blueberries, and cranberries are other great examples of naturally occurring indicators. These are all due to the same anthocyanin molecule found in the red cabbage.

Some flowers are also natural indicators. Hydrangea is a common garden plant with flowers that come in many colors, depending on the pH of the soil. A hydrangea plant with blue flowers indicates that the soil is acidic, while creamy white flowers mean the soil is neutral and pink flowers mean the soil is basic.



FIGURE 21.1

A hydrangea plant with blue flowers. What does the flower color indicate about the pH of the soil?

Synthetic indicators are compounds created in a chemistry lab rather than compounds found in nature. Both naturally occurring indicators and synthetic indicators are weak organic acids or bases. For example, a common synthetic indicator used in most chemistry laboratories is phenolphthalein. The chemical structure of phenolphthalein is shown in the figure below.

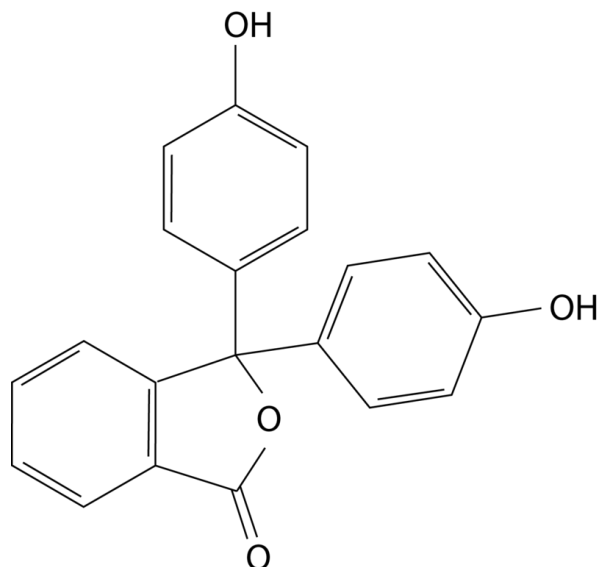

This indicator changes color at a pH of 8.2. Below 8.2 it is colorless, and above 8.2 it is bright pink. There are many common synthetic indicators that are useful in the chemistry laboratory. When dealing with a more acidic range, chemistry students may use methyl orange. The structure for methyl orange is shown below.

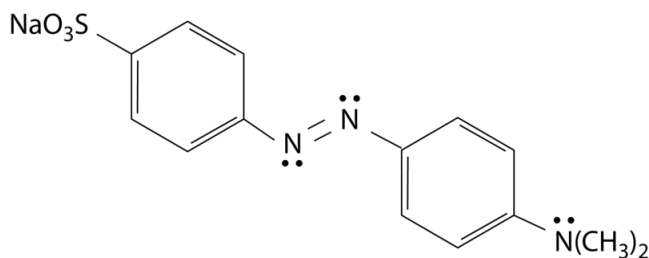

Methyl orange changes color from pH 3.2 to 4.4. Below 3.2, the color of the indicator is red. Above 4.4, the color of the indicator is yellow. In between 3.2 and 4.4, there are various shades of orange, hence the name.

There are two requirements for a substance to function as an acid-base indicator: 1) the substance must have an equilibrium affected by hydrogen ion concentration, and 2) the two forms of the compound on opposite sides of the equilibrium must have different colors. Most indicators function in the same general manner and can be presented by a generic indicator equation. In the equation below, we represent in the indicator ion with a hydrogen ion attached as HIn , and we represent the indicator ion without the hydrogen attached as In^- .

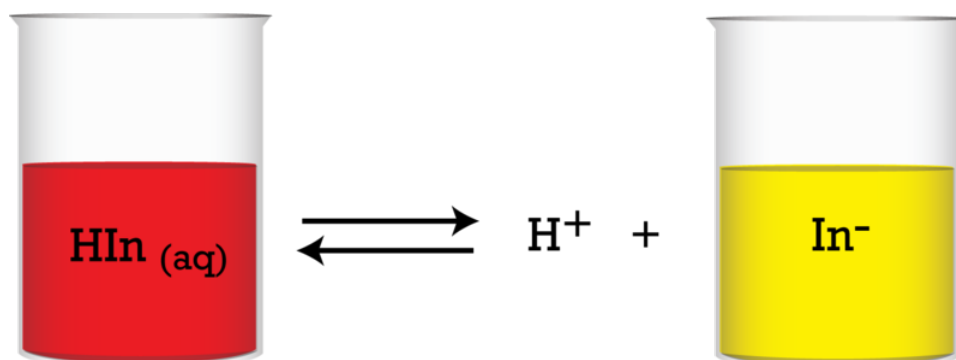

Since the indicator itself is a weak acid, the equilibrium between the protonated form and the anionic form is controlled by the hydrogen ion concentration. For the example above, the protonated form is colored red and the

anionic form is colored yellow. If we add hydrogen ion to the solution, the equilibrium will be driven toward the reactants and the solution will turn red. If we add base to the solution (reduce hydrogen ion concentration), the equilibrium will shift toward the products and the solution will turn yellow. It is important to note that if this indicator changes color at $\text{pH} = 5$, then at all pH values less than 5, the solution will be red and at all pH values greater than 5, the solution will be yellow. Therefore, putting this indicator into a solution and having the solution turn yellow does NOT tell you the pH of the solution, it only tells you that the pH is greater than 5. At pH values less than 5, the great majority of the indicator molecules are in the red form and the solution will be red. At pH values greater than 5, the great majority of the indicator particles will be in the yellow form and the solution will be yellow. The equilibrium between these indicator particles is such that the particles will be 50% red form and 50% yellow form at exactly $\text{pH} = 5$. Therefore, at $\text{pH} = 5$, the actual color of the solution will be a 50-50 mixture of red and yellow particles and the solution will be orange, as demonstrated in the figure below.

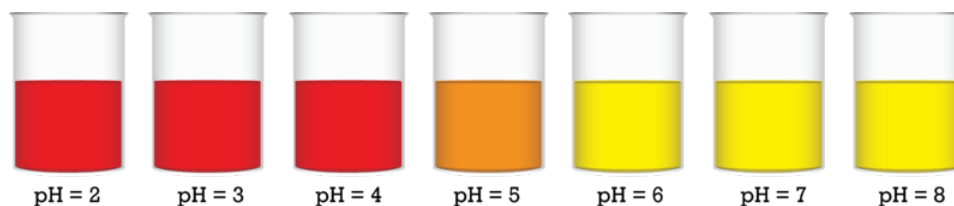

Many indicators are available to help determine the pH of solutions. A list of the most common indicators is found in **Table 21.2**, along with their respective color change pH values and corresponding color changes.

TABLE 21.2: Colors and pH Ranges for Common Indicators

Indicator	pH Range	Color Change
Methyl Violet	0.0 – 1.6	Yellow - Blue
Thymol Blue	1.2 – 2.8	Red - Yellow
Orange IV	1.3 – 3.0	Red - Yellow
Methyl Orange	3.2 – 4.4	Red - Orange
Bromophenol Blue	3.0 – 4.7	Orange/Yellow - Violet
Congo Red	3.0 – 5.0	Blue - Red
Bromocresol Green	3.8 – 5.4	Yellow - Blue
Methyl Red	4.8 – 6.0	Red - Yellow
Litmus	5.0 – 8.0	Red - Blue
Chlorophenol Red	4.8 – 6.2	Yellow - Red
Bromothymol Blue	6.0 – 7.6	Yellow - Blue
Phenol Red	6.4 – 8.2	Yellow - Red/Violet
Thymol Blue	8.0 – 9.6	Yellow - Blue
Phenolphthalein	8.2 – 10.0	Colorless - Pink
Alizarin Yellow R	10.1 – 12.0	Yellow - Red
Methyl Blue	10.6 – 13.4	Blue - Pale Violet
Indigo Carmine	11.4 – 13.0	Blue - Yellow

There are many more indicators than are shown in **Table 21.2**, but these are ones that you may find in common chemistry classroom laboratories. One example of an indicator not found in the table is known as the universal indicator. The universal indicator is a solution that has a different color for each pH from 0 – 14. Universal indicator is produced by creatively mixing many of the individual indicators together so that a different color is achieved for each different pH . It is used for many types of experiments to determine if solutions are acids or bases and where on the pH scale the substance belongs. The chart below indicates the colors of universal indicator for different pH values.

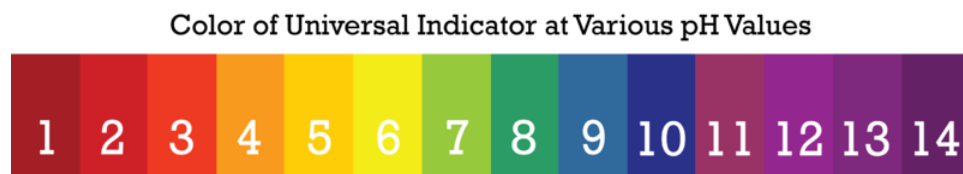
**Example:**

If the pH of the solution is 4.8, what would be the color of the solution if the following indicators were added?

1. Universal indicator
2. Bromocresol Green
3. Phenol red

Solution:

1. Universal indicator = Orange to orange-yellow
2. Bromocresol Green = green (midway pH = 4.6)
3. Phenol red = yellow

Example:

A solution found in the laboratory was tested with a number of indicators. These were the results:

- Phenolphthalein was colorless
- Bromocresol green was blue
- Methyl red was yellow
- Phenol red was yellow

What was the pH of the solution?

Solution:

- Phenolphthalein was colorless, pH < 8.0
- Bromocresol green was blue, pH > 5.4
- Methyl red was yellow, pH > 6.0
- Phenol red was yellow, pH < 6.4

Therefore, the pH of the solution must be between 6.0 and 6.4.

The Titration Process

One of the properties of acids and bases is that they neutralize each other. In the laboratory setting, an experimental procedure where an acid is neutralized by a base (or vice versa) is known as titration. **Titration** is the addition of a known concentration of base (or acid), also called the **titrant**, to a solution of acid (or base) of unknown concentration. Since both volumes of the acid and base are known, the concentration of the unknown solution is then mathematically determined.

When doing a titration, you need to have a few pieces of equipment. A burette like the one shown below is used to accurately dispense the volume of the solution of known concentration. An Erlenmeyer flask is used to hold a known volume of the solution whose concentration is unknown. A few drops of the indicator are added to the flask

before you begin the titration. The **endpoint** is the point where the indicator changes color, which tells us that the acid is neutralized by the base. The **equivalence point** is the point where the number of moles of acid exactly equals the number of moles of base.

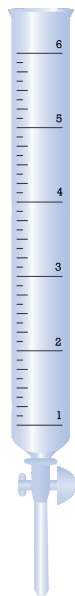

Some laboratories have pH meters that measure this point more accurately than the indicator. The diagram below shows a simplified version of a pH meter with the probe from the meter immersed in a mildly alkaline solution (pH = 8.03). The two knobs on the meter are used to calibrate the instrument.

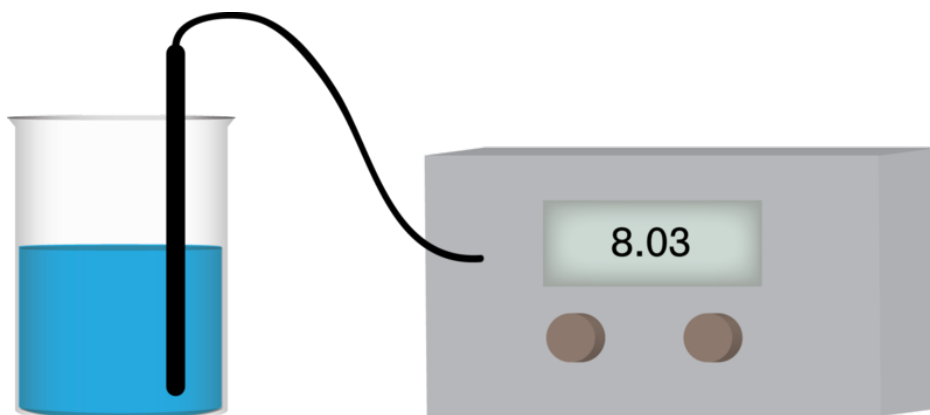

An example of a typical electronic pH meter with the attached probes is shown below. The main purpose of a pH meter in this experiment is to measure the changes in pH as the titration goes from start to finish.



A typical titration setup is shown below. The burette is upright and ready to drip the solution into the flask holding the solution of unknown concentration and the few drops of indicator. When the indicator changes color, the number of moles of acid equals the number of moles of base and the acid (or base) has been neutralized.

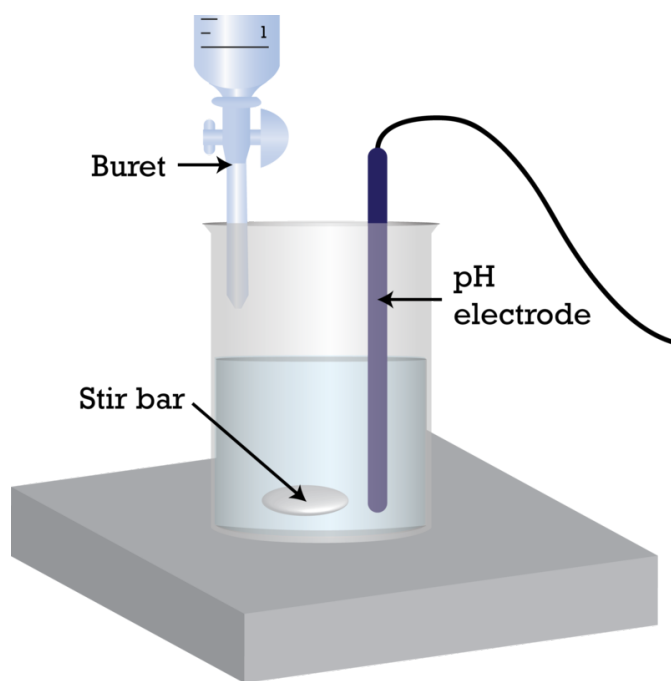

There are three types of titrations that are normally performed in the laboratory in order to determine the unknown concentration of the acid or base. These three types are:

1. Strong acid vs. Strong base
2. Strong acid vs. Weak base
3. Weak acid vs. Strong base

In these titrations, a pH meter may be used to measure the changes in the pH as the titration goes to completion. If so, a titration curve can be constructed. A **titration curve** is a graph of the pH versus the volume of titrant added. Let's

take a look at how each of these types of titrations differs in terms of their pH curves and their pH at the equivalence point.

(1) Strong Acid vs. Strong Base

For a strong acid vs. a strong base titration, let's assume the strong base is the titrant. Therefore, the Erlenmeyer flask contains the strong acid and a few drops of your indicator. The initial pH of the solution in the flask will likely be low since the solution is a strong acid. As the base is added, the acid is slowly neutralized. At first the change in pH is minimal. This is due to the fact that the flask has a much greater number of H_3O^+ ions than OH^- ions available from the added titrant.

As more and more base is added, more OH^- ions are added and thus more H_3O^+ ions get neutralized. Let's stop here and look at the reaction. The equation below shows the total ionic equation of a reaction between a strong acid and a strong base:

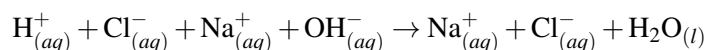

The next equation shows the net ionic equation for the reaction between the strong acid and the strong base:

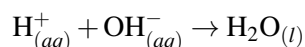

As we add more OH^- ions, more H_3O^+ (or H^+) ions are being neutralized. Since these two ions react to form water, a neutral solution will eventually be formed. For a strong acid and a strong base, this means the $\text{pH} = 7.0$ at the point of neutralization. If we continue to add the titrant (containing OH^- ions) after all of the H_3O^+ ions have been neutralized, the pH will continue to rise as more base is added and there are excess OH^- ions.

Now that we know what happens in a strong acid-strong base titration, what does the titration curve look like? The main points described above are shown in the titration curve below.

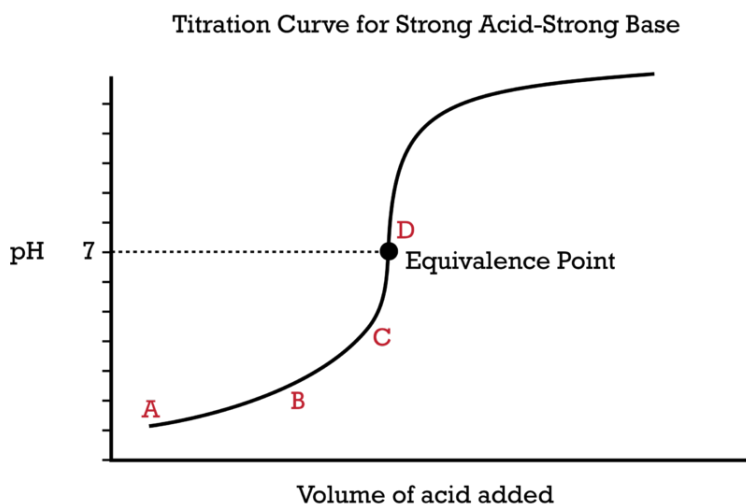

The points A through D sum up the description of the events that take place during the titration. Point A is the start of the titration. Point B is the midpoint, the point where half of the H^+ ions have been neutralized. Point D is the equivalence point.

(2) Strong Acid vs. Weak Base

What would happen if we were to titrate a strong acid with a weak base or vice versa? The titration curve for a weak base-strong acid titration is shown below. Try to determine what is happening in the titration just by looking at the graph.

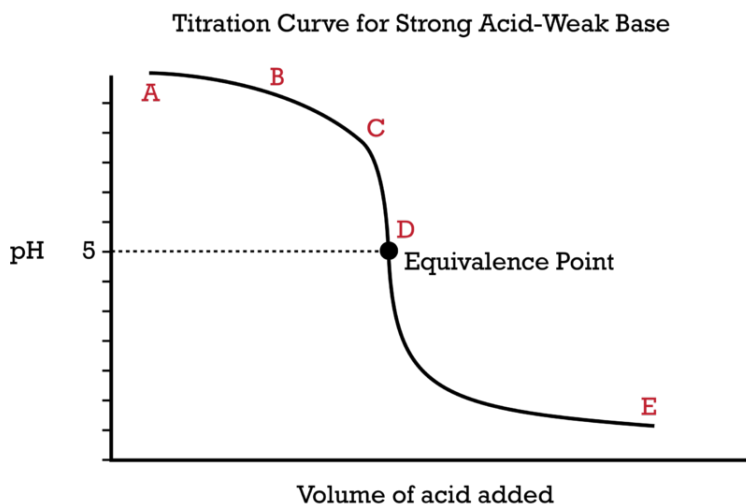

As the acid (the titrant) is added, the pH decreases as the H_3O^+ ions begin to neutralize the OH^- ions. Point D is the equivalence point. Notice that for a weak base and a strong acid titration, the pH at equivalence point is acidic. The equation for the reaction between NH_3 , a weak base, and HCl , a strong acid, is shown below:

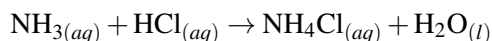

The ionic equation is:

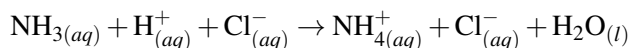

(3) Weak Acid vs. Strong Base

The third type of titration is that of a weak acid with a strong base. When we follow through with the same procedure as the previous two titrations, we can determine a great deal of information simply by looking at the pH curve. For example, let's consider the titration of a solution of acetic acid, $\text{HC}_2\text{H}_3\text{O}_2$, with a solution of potassium hydroxide, KOH . We can write the chemical reaction for this acid-base neutralization and begin to draw a rough sketch of a titration curve:

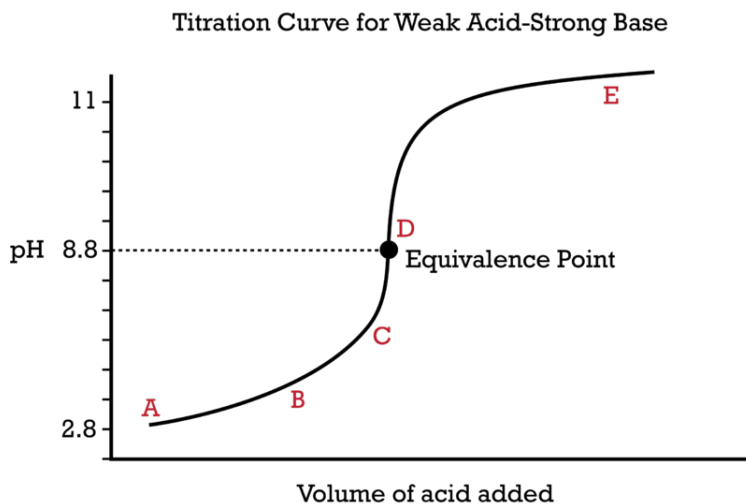
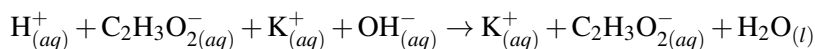

The points on the curve represent the same points as with the other two titration curves. Look, however, at the equivalence point. Notice how the pH for the equivalence point of the weak acid-strong base titration is above 7.0.

Example:

Draw a rough sketch of the titration curve between nitric acid and ethylamine, CH_3NH_2 . Assume the acid is in the burette. What is the estimated pH at the equivalence point?

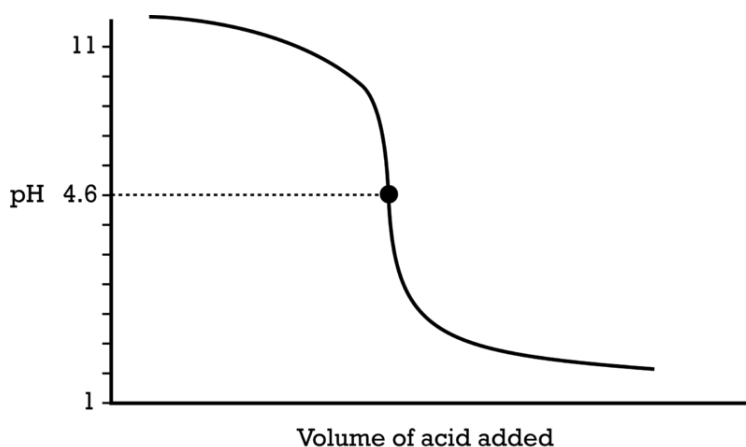
Solution:

The pH at the equivalence point is approximately 4.6 from this graph.

The titrant is the solution of known concentration. For accuracy reasons, this titrant is normally titrated to find its exact concentration before beginning the desired titration. The purpose of this initial titration is to determine, with as much accuracy as possible, the exact concentration of the solution in the burette. To determine the exact concentration of the titrant, we use a standard solution. A **standard solution** is a solution whose concentration is known exactly. Standard solutions have this property because these chemicals are normally found in pure, stable forms. Examples of chemicals used to prepare standard solutions are potassium hydrogen phthalate, $\text{KHC}_8\text{H}_4\text{O}_4$ (sometimes referred to as KHP), and sodium carbonate, Na_2CO_3 .

When using a standard solution, the standard is first prepared by dissolving the solid in a known volume of water, adding a few drops of indicator, and titrating with the solution that you want to standardize.

Example:

What is the concentration of a sodium hydroxide solution if 32.34 mL is required to neutralize a solution prepared by dissolving 1.12 g of $\text{KHC}_8\text{H}_4\text{O}_4(s)$ in 25.00 mL of H_2O ?

Solution:

Step 1: Find the moles of $\text{KHC}_8\text{H}_4\text{O}_4$.

$$\text{moles KHC}_8\text{H}_4\text{O}_4 = \frac{\text{mass}}{\text{molar mass}} = \frac{1.12\text{g}}{204.2\text{ g/mol}} = 5.48 \times 10^{-3}\text{ mol}$$

Step 2: Use mole ratio from the reaction to find the moles of NaOH.

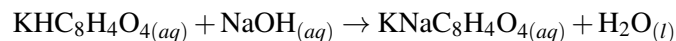

Since the reaction is 1:1, 1 mole of KHP reacts with every mole of NaOH.

$$\text{mol NaOH} = 5.48 \times 10^{-3}\text{ mol}$$

Step 3: Determine the concentration of NaOH.

$$[\text{NaOH}] = \frac{5.48 \times 10^{-3}\text{ mol}}{0.03234\text{ L}} = 0.170\text{ M}$$

Therefore, the exact concentration of the sodium hydroxide solution used in the titration is 0.170 mol/L.

Choosing an Appropriate Indicator

To choose an appropriate indicator for a titration, a titration curve is useful. Knowing the pH at equivalence for the different types of titrations (see **Table 21.3**) is also necessary.

TABLE 21.3: pH at Equivalence for Titrations

Type of Titration	pH at Equivalence
Strong Acid – Strong Base	pH = 7
Strong Acid – Weak Base	pH < 7
Weak Acid – Strong Base	pH > 7

Choosing an indicator close to the equivalence point is essential to see the point where all of the H^+ ions and OH^- ions have been neutralized. The color change should occur on or around the equivalence point. So, for example, with a strong acid-strong base titration, the pH at equivalence is 7.0. Indicators such as bromothymol blue (pH range = 6.0 - 7.6) and phenol red (pH range = 6.6 - 8.0) are common. Notice the midpoint color (green) for bromothymol blue would appear at a pH = 6.8, which is close to 7.0. For phenol red, the midpoint color (orange) would appear at pH = 7.3, again close to 7.0.

The same process is used for other titration types. For a strong acid-weak base titration where the pH at equivalence is less than 7, the indicators normally chosen are methyl red (pH range = 4.8 - 6.0) and chlorophenol red (pH range = 4.8 - 6.2). For a weak acid-strong base titration, where the pH at equivalence is greater than 7, the indicators normally chosen are phenolphthalein (pH range = 8.2 - 10) and thymol blue (pH range = 8.0 - 9.6). As with strong acid-strong base titrations, the visual observation of the indicator's midpoint color should signal close proximity to the equivalence point.

Example:

Look at the graph below and determine the appropriate indicator.

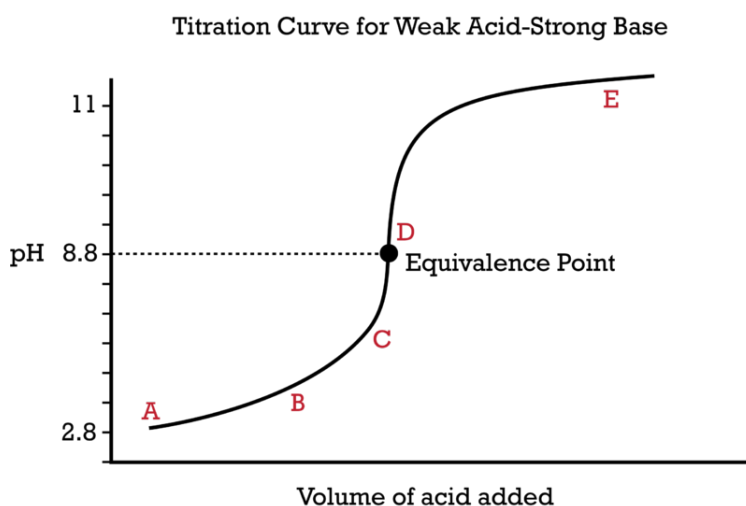

Solution:

We first look at the graph and mark the vertical stretch of the titration curve in order to find the half-way mark on this vertical stretch. Looking at the graph, when we follow this half-way mark over to the y-axis, we can see that the equivalence point occurs at approximately pH = 8.8. The indicator appropriate to use would be phenolphthalein (pH range = 8.2 - 10). As soon as the pink color forms, we are at the equivalence point.

There is an interesting observation about the endpoint that has yet to be mentioned. The endpoint was defined earlier as the point where the indicator changes color. In an acid-base neutralization reaction, this point may not be the point where all of the H^+ ions have been neutralized by OH^- ions, or vice versa. The experimenter continues titration until the indicator changes color, that is, the endpoint has been reached. The equivalence point is the point where the moles of hydrogen ion and the moles of hydroxide ion are equal. It requires knowledge by the experimenter to select an indicator that will make the endpoint as close as possible to the equivalent point.

The Mathematics of Titration

For the calculations involved here, we will only use our acid and base examples where the stoichiometric ratio of H^+ and OH^- is 1:1. To determine the volume required to neutralize an acid or a base, or in other words, to reach the equivalence point, we will use a formula similar to the dilution formula:

$$M_a \times V_a = M_b \times V_b$$

where M_a is the molarity of the acid, V_a is the volume of the acid, M_b is the molarity of the base, and V_b is the volume of the base. Note that if the acid and base do not neutralize each other in a 1:1 ratio, this equation does not hold true.

Example:

When 10.0 mL of a 0.125 mol/L solution of hydrochloric acid, HCl, is titrated with a 0.100 mol/L solution of potassium hydroxide, KOH, what is the volume of the hydroxide solution required to neutralize the acid? What type of titration is this?

Solution:

Step 1: Write the balanced ionic chemical equation.



Step 2: Use the formula and fill in all of the given information.

$$M_a \times V_a = M_b \times V_b$$

$$M_a = 0.125 \text{ mol/L}$$

$$V_a = 10.0 \text{ mL}$$

$$M_b = 0.100 \text{ mol/L}$$

$$V_b = ?$$

$$M_a \times V_a = M_b \times V_b$$

$$V_b = \frac{M_a \times V_a}{M_b} = \frac{(0.125 \text{ mol/L})(10.0 \text{ mL})}{0.100 \text{ mol/L}} = 12.5 \text{ mL}$$

Therefore, for this strong acid-strong base titration, the volume of base required is 12.5 mL.

This video shows the technique for performing a titration using an indicator: <http://www.youtube.com/watch?v=9DkB82xLvNE> (5:03).

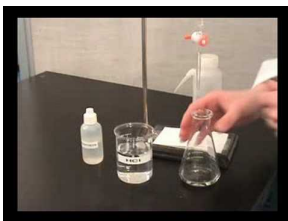

MEDIA

Click image to the left for more content.

Lesson Summary

- An indicator is a substance that changes color at a specific pH and is used to indicate the pH of the solution relative to that point.
- A natural indicator is an indicator that is a naturally occurring substance.
- Indicators are normally weak organic acids or bases with complicated structures.
- Universal indicator is a mixture of indicators that produces a different color for each pH from 0 – 14.
- A titration is the addition of a known concentration of base (or acid) to a solution of acid (or base) of unknown concentration.
- The titrant is the solution of known concentration. This solution is normally in the burette.
- The endpoint is the point in the titration where the indicator changes color.
- The equivalence point is the point in the titration where the number of moles of acid equals the number of moles of base.
- The three types of titrations usually performed in the laboratory are: strong acid vs. strong base, strong acid vs. weak base, and weak acid vs. strong base.
- A titration curve is a graph of the pH versus the volume of titrant added.
- For a strong acid vs. strong base titration, the *pH* at equivalence is 7.0. For a strong acid vs. weak base titration, the pH at equivalence is less than 7.0. For a weak acid vs. strong base titration, the pH at equivalence is greater than 7.0.
- A standard solution is a solution whose concentration is known exactly and is used to find the exact concentration of the titrant.
- For titrations where the stoichiometric ratio of mol H⁺ to mol OH⁻ is 1:1, the concentrations or volumes for the unknown acid or base can be calculated with the formula $M_a \times V_a = M_b \times V_b$.

Further Reading / Supplemental Links

The following link is to a video about acid-base neutralization and titration.

- <http://link.brightcove.com/services/player/bcpid9113583001?bctid=1405713919>

The video at the link below shows the lab techniques needed for titration.

- <http://chem-ilp.net/labTechniques/TitrationVideo.htm>

This video is a ChemStudy film called “Acid Base Indicators.” The film is somewhat dated but the information is accurate.

- <http://www.youtube.com/watch?v=yi8QrjmV6Sw>

Review Questions

1. Why do you think there would be more experimental error when using an indicator instead of a pH meter during a titration?
2. Which of the following definitions best suits that of an endpoint?
 - a. The stoichiometric point where the number of moles of acid equals the number of moles of base.

- b. The visual stoichiometric point where the number of moles of acid equals the number of moles of base.
 c. The midpoint of the vertical stretch on the titration curve.
 d. None of the above
3. In the following titration curve, what pair of aqueous solutions would best represent what is shown to be happening in the curve?
- $\text{HCOOH}_{(aq)} + \text{NH}_3_{(aq)}$
 - $\text{HCOOH}_{(aq)} + \text{NaOH}_{(aq)}$
 - $\text{H}_2\text{SO}_{4(aq)} + \text{Ba}(\text{OH})_{2(aq)}$
 - $\text{HClO}_{4(aq)} + \text{NH}_3_{(aq)}$

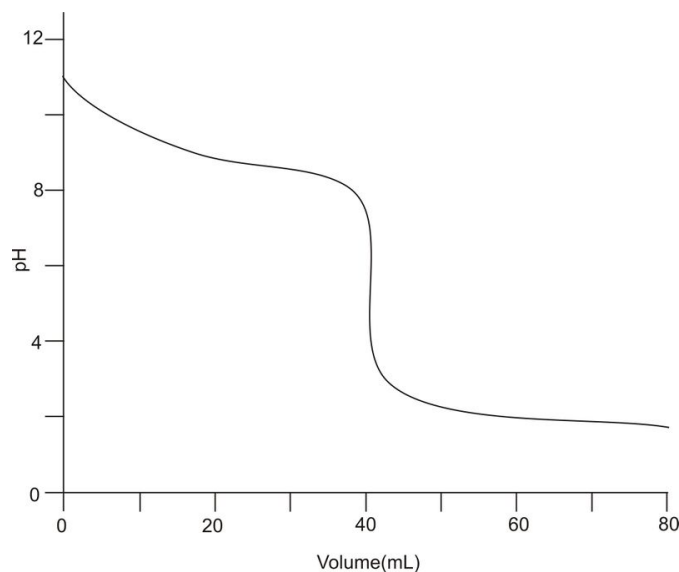

4. What would be the best indicator to choose for the pH curve shown in question 3?
- Methyl red
 - Litmus
 - Phenolphthalein
 - Phenol red
5. What is the best indicator to use in the titration of benzoic acid with barium hydroxide?
- Methyl violet, range = 0.0 – 1.6
 - Bromothymol blue, range = 3.0 – 4.7
 - Phenolphthalein, range = 8.2 – 10.0
 - Methyl blue, range = 10.6 – 13.4
 - Indigo carmine, range = 11.4 – 13.0
6. If 22.50 mL of a sodium hydroxide solution is necessary to neutralize 18.50 mL of a 0.1430 mol/L HNO_3 solution, what is the concentration of NaOH?
- 0.1176 mol/L
 - 0.1430 mol/L
 - 0.1740 mol/L
 - 2.64 mol/L
7. Calculate the concentration of hypochlorous acid if 25.00 mL of HClO is neutralized by 32.34 mL of a 0.1320 mol/L solution of sodium hydroxide.

21.3 Buffers

Lesson Objectives

The student will:

- define and give an example of a buffer.
- explain the effect of a strong acid or base on a buffer system.
- explain the mechanism by which a buffer solution resists changes in pH.
- given appropriate information, calculate the pH of a buffer.
- describe how to make a buffer solution.

Vocabulary

- buffer

Introduction

There are many situations in which it is desirable to keep the pH of a solution close to a particular value even though quantities of acids and/or bases are added to the solution. Many organic and biochemical reactions require acids or bases, but if the pH goes too high or too low, the products will be destroyed. For these reactions, it is necessary to keep the pH within a very small range even while acids or bases are added to the reaction. Chemists use mixtures called buffers to keep the reaction solutions within the necessary pH range. **Buffers** are mixtures of chemicals that cause a solution to resist changes in pH.

Buffers are very important to many biological reactions. Human blood is a substance whose function is very dependent on the function of buffers. Human blood must maintain a nearly constant pH between 7.3 and 7.5. A change of just 0.2-0.4 pH units outside this range could cause loss of consciousness or even death. The pH of human blood can change slightly depending on foods we eat and the rate at which we inhale and exhale CO_2 . Fortunately, the human blood stream has buffers that are able to resist these pH changes.

Buffers

A buffer is a solution that maintains the pH level when small amounts of acid or base are added to the system. Buffer solutions contain either a weak acid and its conjugate base or a weak base and its conjugate acid. A common procedure for producing a buffer in the lab is to make a solution containing both a weak acid and a salt of its conjugate base.

For example, you could make a buffer by preparing a solution containing acetic acid and sodium acetate. This common buffer would contain acetic acid, CH_3COOH , and the acetate ion, CH_3COO^- . The solution will remain

in the pH range of 3.7 – 5.8 even if small amounts of acids or bases are added. Another example is a solution of hydrogen phosphate, HPO_4^{2-} , plus the phosphate, PO_4^{3-} . This will buffer a solution in the pH range of 11.3 - 13.3.

How is it possible that a solution will not change its pH when an acid or base is added? Let's examine the acetic acid/acetate ion buffer. The ionization equation for acetic acid is shown below.

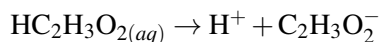

If acid (H^+ ions) is added to this solution, the equilibrium will shift toward the reactants to use up some of the added hydrogen ions. Equilibrium will be re-established in the solution with different concentrations of the three species in the reaction. Although the H^+ concentration will be higher than its initial value, the change will be partially corrected due to the presence of $\text{C}_2\text{H}_3\text{O}_2^-$ ions. Similarly, if a base is added to this solution, the base will remove hydrogen ions and the equilibrium will shift to the right to partially counteract the stress. Again, equilibrium will be re-established with new concentrations. The existence of large quantities of both undissociated acid molecules and acetate ions in the solution is what allows the buffer to consume quite a large amount of added acid or base without the pH changing significantly.

Examine what happens to 1.00 liter of pure water to which 0.100 mole of gaseous HCl is added. The original concentration of hydrogen ion in the pure water is 1.00×10^{-7} M and therefore, the pH is 7. After the 0.100 mole of HCl is added, the concentration of hydrogen ions will be 0.100 M (plus the original 1.00×10^{-7} M, which can be neglected as insignificant). This new concentration of hydrogen ions will produce a pH = 1. So, the addition of the 0.100 mole of gaseous HCl caused the pH of the pure water to change from 7 to 1.

Let's now see what happens if this same amount of gaseous HCl is added to an acetic acid-acetate ion buffer. Let's say we made this solution to contain 0.50 M acetic acid and 0.50 M acetate ion (0.50 M sodium acetate which fully dissociated). The acetic acid dissociation equation will reach equilibrium at its K_a is 1.8×10^{-5} .

$$K_a = \frac{[\text{H}^+][\text{C}_2\text{H}_3\text{O}_2^-]}{[\text{HC}_2\text{H}_3\text{O}_2]} = 1.8 \times 10^{-5}$$

We know both the acetic acid and the acetate ion concentrations will be 0.50 M, so we can plug these values into the expression and solve for $[\text{H}^+]$.

$$[\text{H}^+] = \frac{(1.8 \times 10^{-5})[\text{HC}_2\text{H}_3\text{O}_2]}{[\text{C}_2\text{H}_3\text{O}_2^-]} = \frac{(1.8 \times 10^{-5})(0.50)}{(0.50)} = 1.8 \times 10^{-5} \text{ M}$$

Then we can insert the hydrogen ion concentration into the pH formula and determine the original pH of the buffer solution.

$$\text{pH} = -\log(1.8 \times 10^{-5}) = 4.74$$

Next, we will add the same 0.100 mole of gaseous HCl to this buffer solution and calculate the pH of the solution after the acid has been added and equilibrium has been re-established.

When we add 0.100 mole HCl gas to this solution, the added hydrogen ion will combine with acetate ion to produce more undissociated acid. A small amount of the newly formed acetic acid may dissociate again, but the amount is minimal and can be neglected. The new $[\text{HC}_2\text{H}_3\text{O}_2]$ will equal 0.60 M (the original 0.50 M plus the added 0.10 M) and the new $[\text{C}_2\text{H}_3\text{O}_2^-]$ will equal 0.40 M (the original 0.50 M minus the 0.10 M that reacted with the added hydrogen ions). We can now plug these values into the K_a expression, calculate the new $[\text{H}^+]$, and find the new pH.

$$K_a = \frac{[\text{H}^+][\text{C}_2\text{H}_3\text{O}_2^-]}{[\text{HC}_2\text{H}_3\text{O}_2]} = 1.8 \times 10^{-5}$$

$$[\text{H}^+] = \frac{(1.8 \times 10^{-5})[\text{HC}_2\text{H}_3\text{O}_2]}{[\text{C}_2\text{H}_3\text{O}_2^-]} = \frac{(1.8 \times 10^{-5})(0.60)}{(0.40)} = 2.7 \times 10^{-5} \text{ M}$$

$$\text{pH} = -\log(2.7 \times 10^{-5}) = 4.57$$

The same quantity of HCl gas that changed the pH of pure water from 7 to 1 has changed the pH of this buffer from 4.74 to 4.57. The change in pH is only 0.17, which is a function of the buffer. Buffers resist change to pH. We could do this same calculation by adding a base instead of an acid and show that the pH increases by this same slight amount. We will leave this as an exercise for you to complete on your own.

Example:

Which of the following combinations would you expect to make a useful buffer solution:

1. $\text{HClO}_4/\text{ClO}_4^-$
2. $\text{CH}_3\text{NH}_2/\text{CH}_3\text{NH}_3^+$

Solution:

1. $\text{HClO}_4/\text{ClO}_4^-$: HClO_4 is a strong acid and buffers are made from weak acids and their conjugate bases or weak bases and their conjugate acids. Therefore, this cannot be made into a buffer.
2. $\text{CH}_3\text{NH}_2/\text{CH}_3\text{NH}_3^+$: CH_3NH_2 is a weak base and CH_3NH_3^+ is the conjugate acid of this base. Therefore, this can be made into a buffer solution.

The first video considers the mathematics of buffer solutions and the second video shows a laboratory example of buffering (**5g; 11 IE Stand.**): http://www.youtube.com/watch?v=O_QIZe4fv4g (10:18), (**5g**) http://www.youtube.com/watch?v=g_ZK2ABUjvA (2:39).

Buffered Solution

- Now add 0.01 M HCl to the buffer solution (ordinary pH would be 2.0)

$$\text{HOBr} + \text{H}_2\text{O} \rightleftharpoons \text{H}_3\text{O}^+ + \text{OBr}^-$$

$$0.11 - x \quad 1 \quad x \quad 0.09 + x$$

$$K_a = \frac{x(0.09+x)}{(0.11-x)} = 6.46 \times 10^{-8}$$

$$x = 7.90 \times 10^{-8} = [\text{H}_3\text{O}^+]$$

$$\text{pH} = -\log_{10}(7.90 \times 10^{-8}) = 4.10$$

- Change in $[\text{H}_3\text{O}^+]$ is only 22%!

MEDIA

Click image to the left for more content.



MEDIA

Click image to the left for more content.

The Buffer in Blood

The primary buffer found in your bloodstream is carbonic acid, H_2CO_3 . The carbonic acid is present due to carbon dioxide from your respiratory system dissolving in water.

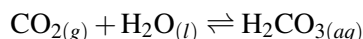

The amount of carbonic acid in your bloodstream is affected by the rate of your respiration. If you breathe rapidly, you reduce the amount of CO_2 in your bloodstream, and the equilibrium shown above shifts toward the reactants, thus lowering the amount of H_2CO_3 . If you breathe slowly, the amount of CO_2 in your bloodstream increases, and the equilibrium shifts toward the products, increasing the amount of H_2CO_3 in your system.

Once the H_2CO_3 is produced by dissolving carbon dioxide, the carbonic acid dissociates in your blood as shown below:

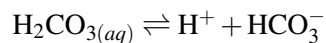

The buffering system in your blood is composed of the weak acid, H_2CO_3 , and its conjugate base, HCO_3^- .

Any changes in blood pH that could be caused by food intake will be buffered by this equilibrium system. If acid is added to your blood, the equilibrium will shift toward the reactants, using up the hydrogen ions. If base were added to your blood, thus reacting with hydrogen ions, the equilibrium will shift toward the products to generate more hydrogen ions. This buffer in your blood is very efficient at keeping your blood pH in the necessary range.

Some people, when they get nervous, begin breathing very fast or very slow. Breathing too fast is called hyperventilating, and breathing too slow is called hypoventilating. Your respiratory rate is normally controlled by the amount of carbon dioxide in the blood. Your body receives instructions to breathe faster or slower to adjust the amount of carbon dioxide in your blood in order to properly regulate the buffer system. When people breathe too fast or too slow because of other reasons, the CO_2 content of the blood becomes incorrect and the pH of the blood rises or lowers outside the acceptable range of 7.3 - 7.5. When this happens, the person can pass out. People who hyperventilate when excited or nervous are sometimes advised to carry a lunch sack or something similar to breathe into when they are feeling light-headed. Breathing into a sack returns air with the same concentration of carbon dioxide that was exhaled. This keeps the amount of carbon dioxide in the blood up and prevents a loss of consciousness.

Lesson Summary

- A buffer is a solution of a weak acid and its conjugate base or a weak base and its conjugate acid that resists changes in pH when an acid or base is added to it.
- Adding a strong acid to a buffer only decreases the pH by a small amount.
- Adding a strong base to a buffer only increases the pH by a small amount.

Further Reading / Supplemental Links

The following link is to a video lecture about acid-base buffers.

- http://www.youtube.com/watch?v=O_QIZe4fv4g

To see a short animated video showing concentration changes as strong acid or base is added to a buffer, follow the link below.

- <http://www.mhhe.com/physsci/chemistry/essentialchemistry/flash/buffer12.swf>

Review Questions

1. Define a buffer solution.
2. One of the following statements of buffers is incorrect. Which one?
 - a. A buffer may be prepared from a weak acid and its conjugate base salt.
 - b. A buffer may be prepared from a weak base and its conjugate acid salt.

- c. A buffer is a solution that can resist changes in pH when any amount of acid or base is added to it.
- d. A buffer is a solution that can resist changes in pH when a small amount of acid or base is added to it.
3. Which of the following pairs of aqueous 1.0 mol/L solutions could be chosen to prepare a buffer: i. $\text{NH}_4\text{HSO}_4(aq)$ and $\text{H}_2\text{SO}_4(aq)$, ii. $\text{HNO}_2(aq)$ and $\text{NaNO}_2(aq)$, iii. $\text{NH}_4\text{Cl}(aq)$ and $\text{NH}_3(aq)$?
- i and iii only
 - ii and iii only
 - i, ii, and iii
 - None of these solutions is a buffer.
4. Which of the following would form a buffer solution if combined in appropriate amounts?
- HCl and NaCl
 - HCN and NaCN
 - H_2S and NaSH
 - HNO_3 and NaNO_3
5. A buffer is made up of a weak acid and a conjugate base. A small amount of acid is added to the buffer. What happens to the resulting solution?
- The acid dissociation constant goes up.
 - The concentration of the weak acid in the buffer goes down.
 - The pH of the solution goes up.
 - The pH remains almost the same.

All images, unless otherwise stated, are created by the CK-12 Foundation and are under the Creative Commons license CC-BY-NC-SA.

21.4 References

1. David Kauffman. [Hydrangeas](#). Public domain

CHAPTER 22**Thermochemistry****Chapter Outline**

22.1 ENERGY CHANGE IN REACTIONS

22.2 ENTHALPY

22.3 SPONTANEOUS PROCESSES

22.4 ENTROPY

22.5 GIBBS FREE ENERGY

22.1 Energy Change in Reactions

Lesson Objectives

The student will:

- define the terms system and surroundings in the context of a chemical reaction.
- identify the system and surroundings in a chemical reaction.
- describe how heat is transferred in endothermic and exothermic reactions.

Vocabulary

- enthalpy
- surroundings
- system

Introduction

Recall from the chapter “Matter and Energy” that energy is defined as the ability to do work. Energy is often divided into two types: kinetic energy and potential energy. Kinetic energy is the energy of motion, while potential energy is the energy of position.

Molecules contain potential energy in their physical states and in their chemical bonds. You will remember that when solid substances were changed into liquid, energy had to be added to provide the heat of melting. That energy was used to pull the molecules further apart, changing solid into liquid. That energy is then stored in the liquid as potential energy due to the greater distances between attracting molecules. For similar reasons, energy also has to be added to convert a liquid into a gas.

Chemical bonds store potential energy in a slightly different way. To understand how chemical bonds store energy, we can view a substance as having maximum potential energy in bonds when all the atoms of the substance are separated from each other and are in atomic form (no bonds). The atoms can then form many different bonds. When bonds form, energy is released and the potential energy of the substance decreases.

All Chemical Reactions Involve Energy

Every system or sample of matter has energy stored in it. When chemical reactions occur, the new bonds formed never have exactly the same amount of potential energy as the bonds that were broken. Therefore, all chemical reactions involve energy changes. Energy is either given off or taken on by the reaction.

Before any reaction can occur, reactant bonds need to be broken. A minimum amount of energy, that is the activation energy, must be supplied before any reaction can take place. This minimum energy might be in the form of heat or electrical current.

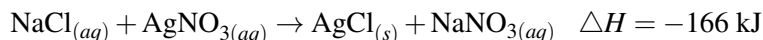

The equation above represents a chemical reaction where energy is produced. This means that there is less energy stored in the bonds of the products than there is in the bonds of the reactants. Therefore, extra energy is left over when the reactants become the products.

In comparison, the decomposition of mercury(II) oxide requires a net input of energy.

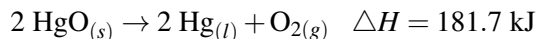

In this reaction, there is less energy stored in the bonds of the mercury(II) oxide than is stored in the bonds of the products. Therefore, extra energy had to be added to the reaction to form the products.

These two equations represent the two types of chemical reactions that involve energy transfer and illustrate that chemical reactions involve energy.

Bond Breaking and Bond Forming

In the previous section, we looked at two different types of reactions that involved energy. ΔH , or the heat of reaction, measures the change in the internal energy of the reaction. The internal energy is the sum of all the energy of the chemical system, that is, the potential and the kinetic. ΔH is also known as change in enthalpy. **Enthalpy** is the amount of energy a system or substance contains and cannot be measured directly. What can be measured is the change in enthalpy (or ΔH). When the bonds of the reactants contain more energy than the bonds of the products, the reaction is exothermic and ΔH is negative. Conversely, when the bonds of the products contain more energy than the bonds of the reactants, the reaction is endothermic and ΔH is positive.

System and Surroundings

Many chemical reactions take place in an open system. Whether the reaction is exothermic or endothermic, there is energy transfer between the system and the surroundings. For example, you take an ice cube out of the refrigerator and place it on a counter. As the ice cube melts, it requires a small amount of heat to be absorbed from the surroundings (the room) in order to produce the liquid.



The system in this example is the ice cube melting to form the liquid water. The surroundings are the container, room, and building where the reaction is taking place. In other words, the **system** involves the reactants and products in the reaction. The **surroundings** are everything else.

Before moving any further in our discussion, it is important to distinguish between heat and temperature when talking about heat transfer. Heat is the total amount of energy that is transferred between the system and the surroundings, while temperature is the average kinetic energy of a substance. The temperature measures the kinetic energy of the reactant and/or product particles. Consider a cup of water and a bucket of water: both will boil at the same temperature (100°C), but it will require different amounts of heat to bring these two volumes of water to a boil.

An endothermic reaction system absorbs heat from the surroundings and has a positive ΔH . Phase changes from a solid to a liquid to a gas are all endothermic. The diagram below illustrates the transfer of heat energy from the surroundings to the system.

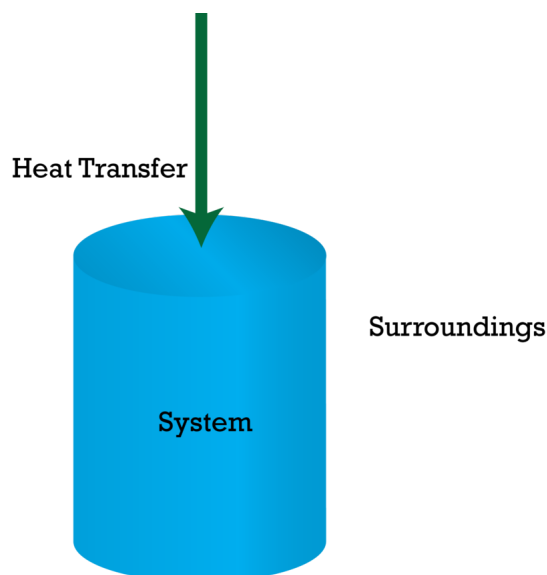

An exothermic reaction system releases heat to the surroundings and has a negative value of ΔH . Just as phase changes from a solid to a liquid to a gas are all endothermic, the reverse of these changes are exothermic. Other reactions that you know as exothermic may be the combustion of fuels. Fuels used to drive your car and heat your home all involve reactions that are exothermic in nature. The figure below illustrates the transfer of heat energy to the surroundings from the system.

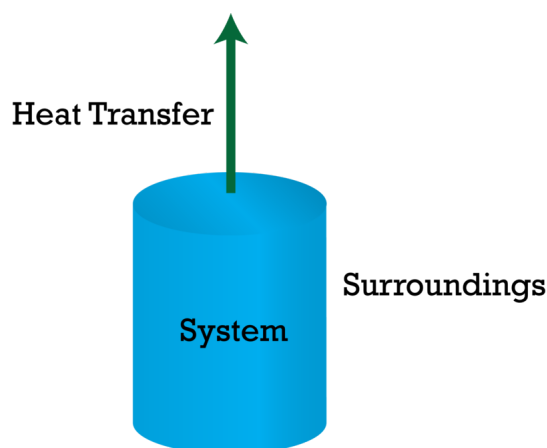

The reason that endothermic reactions have positive ΔH s and exothermic reactions have negative ΔH s is because the definition of ΔH is:

$$\Delta H = H_{\text{products}} - H_{\text{reactants}}$$

Therefore, when the reactants contain more potential energy in their bonds than do the products, energy is given off. Looking at the equation above, since a larger number is subtracted from a smaller one, the answer is negative.

Example:

Which of the following processes are endothermic, and which are exothermic?

1. water boiling
2. gasoline burning
3. water vapor condensing
4. iodine crystals subliming
5. ice forming on a pond

Solution:

1. endothermic – state change from liquid to a gas absorbs heat from the surroundings
2. exothermic – combustion releases heat to the surroundings
3. exothermic – state change from gas to a liquid releases heat to the surroundings
4. endothermic – state change from solid to a liquid absorbs heat from the surroundings
5. exothermic – state change from liquid to a solid releases heat to the surroundings

Lesson Summary

- ΔH , or the heat of reaction, measures the change in the enthalpy of the reaction.
- The enthalpy is the sum of all the energy in a chemical system.
- The system involves the reactants and products in the reaction.
- The surroundings are everything else.
- An endothermic reaction system absorbs heat from the surroundings. An exothermic reaction system releases heat to the surroundings.

Review Questions

1. How does a campfire involve energy? Is it endothermic or exothermic? What would be the system and what would be the surroundings?
2. If a chemical reaction absorbs heat from the surroundings, it is said to be what?
 - a. in equilibrium
 - b. in a closed system
 - c. an exothermic reaction
 - d. an endothermic reaction
3. If a chemical reaction releases heat to the surroundings, it is said to be what?
 - a. in equilibrium
 - b. in a closed system
 - c. an exothermic reaction
 - d. an endothermic reaction
4. Symbolically, change in enthalpy is represented as:
 - a. H
 - b. ΔH
 - c. E
 - d. ΔE
5. Which of the following processes would be endothermic?
 - a. natural gas burning
 - b. melting chocolate

- c. fireworks exploding
 - d. Steam condensing
6. Which of the following processes would be exothermic?
- a. gasoline burning
 - b. evaporation of ether
 - c. melting butter
 - d. boiling water

22.2 Enthalpy

Lesson Objectives

The student will:

- define and understand enthalpy of reaction.
- calculate the enthalpy of reaction, ΔH_{rxn} .
- define and understand ΔH_f .
- define Hess's law.
- calculate ΔH_{rxn} using Hess's law.

Vocabulary

- enthalpy of formation
- Hess's law

Introduction

The change in enthalpy for a reaction can be determined by three methods. First, the enthalpy of the reaction can be found by finding the difference between the enthalpies of the products and reactants in the lab using a calorimeter. Second, the change in enthalpy for a reaction can also be calculated using the heats of formation of all the reactants and products. Thirdly, the change in enthalpy can be calculated using the mathematical application of Hess's Law, which will be introduced in this lesson.

The Energy Content of a System

Enthalpy has been defined previously as the measure of the total internal energy of a system. The difference between the enthalpy of the reactants and the enthalpy of the products is called the change in enthalpy. When reactions take place in an open system, such as a beaker or a container on a counter, the pressure in the system is constant because the pressure is the atmospheric pressure in the room. The change in enthalpy for reactions occurring under constant pressure is also called the ΔH or heat of reaction.

$$\Delta H_{\text{rxn}} = \Delta H_{\text{products}} - \Delta H_{\text{reactants}}$$

Remember that for an endothermic reaction, the value of ΔH is positive, therefore the $\Delta H_{\text{products}}$ must be greater than $\Delta H_{\text{reactants}}$. To illustrate this, look at the potential energy diagram below.

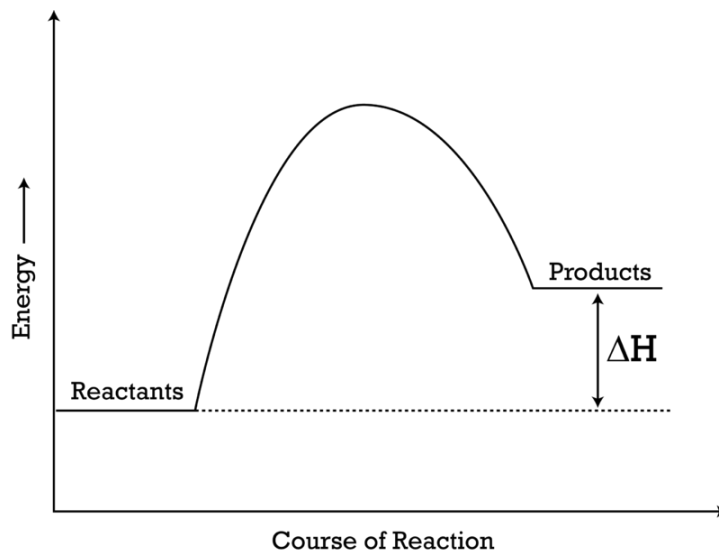

In the figure above, the enthalpy of the reactants is lower than the energy of the products. Therefore, energy must be input into the reaction, and the value of the ΔH will be positive.

The opposite is true for exothermic reactions. For exothermic reactions, the value of ΔH is negative. Therefore, the enthalpy of the products must be less than enthalpy of the reactants. Notice that in the exothermic reaction below, the energy of the reactants is higher than the energy of the products. Therefore, the value of the ΔH will be negative.

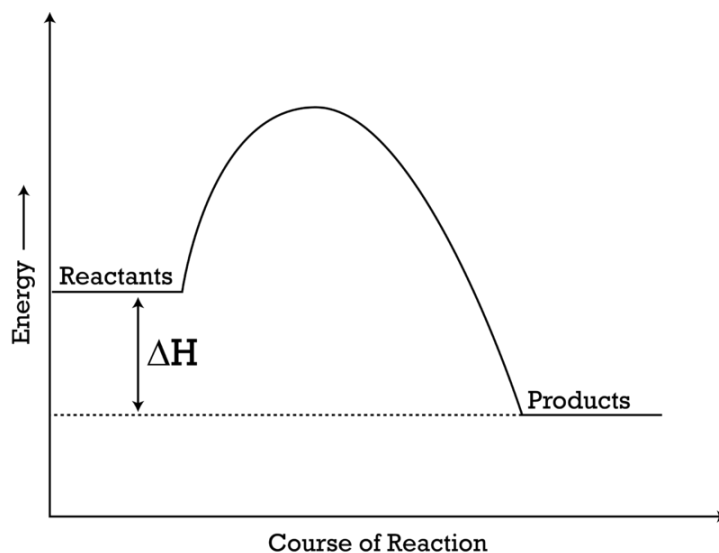
**Example:**

Using the diagram below, answer questions 1-4.

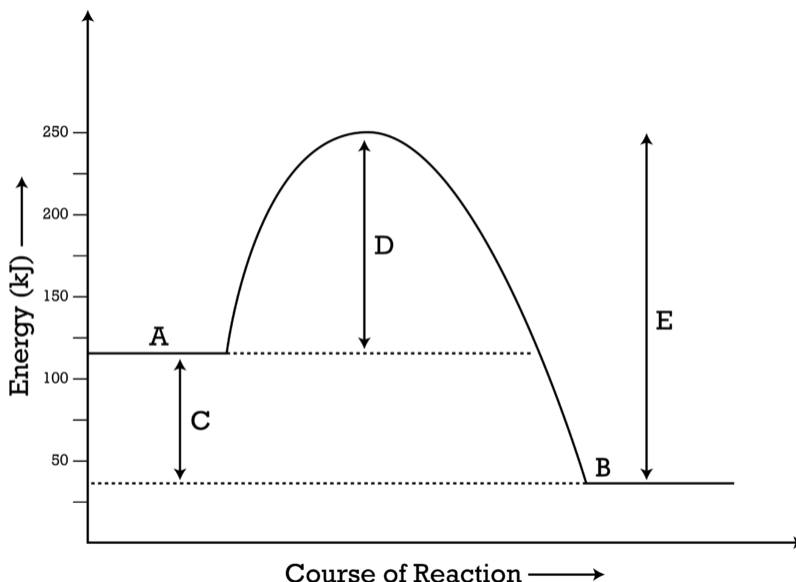

1. Which letter represents the activation energy for the reaction? What is its value?
2. Which letter represents the change in enthalpy of the reaction or the ΔH ? What is its value?
3. Is the reaction endothermic or exothermic? How can you tell?
4. What does the letter E represent?

Solution:

1. The activation energy is represented by letter D. It has a value of $250 - 120 = 130$ kJ.
2. The enthalpy change (ΔH) is represented by letter C. It has a value of $35 - 120 = -85$ kJ.
3. The reaction is exothermic because ΔH is negative and the products are lower than the reactants on the potential energy diagram.
4. Letter E represents the activation energy for the reverse reaction.

Enthalpy of Formation

A formation reaction is a reaction in which exactly one mole of a product is formed from its elements. The **enthalpy of formation**, ΔH_f , is the energy required to form one mole of a substance from its constituent elements at standard temperature and pressure. The equation below represents the ΔH_f for the formation of one mole of $\text{NH}_3(g)$:

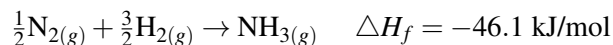

We can find the values for enthalpies of formation using a table of standard molar enthalpies found in the *CRC Handbook of Chemistry and Physics*, online, or in most chemistry textbooks. The values found in these sources are the values of ΔH_f .

In the equation below, exactly one mole of ammonia is formed from its elements and that qualifies the reaction as a formation reaction and its ΔH to be a ΔH_f . In comparison, the equation below does not qualify to be a formation reaction.

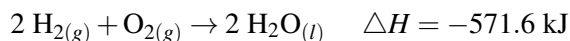

The equation above shows the formation of two moles of water, so it does not represent ΔH_f . In order to represent the ΔH_f for water, we must divide the equation by two:

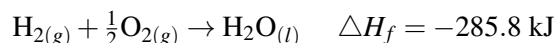

If we were to reverse this reaction, look at what would happen to the value of ΔH :

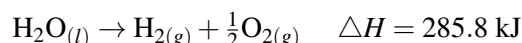

The equation no longer represents the heat of formation because the equation represents a decomposition reaction. However, look at the value of ΔH . Since the equation was reversed, the sign of the value of ΔH was also reversed. 285.8 kJ was released when one mole of water formed from its elements, so to decompose that mole of water back into its elements, an input of 285.8 kJ is required. The ΔH for the forward reaction will be exactly the opposite of the ΔH for the reverse reaction.

You can use the values of ΔH_f found in **Table 22.1** of standard heats of formation to find the enthalpy of a reaction (or ΔH_{rxn}).

TABLE 22.1: Standard Enthalpy of Formation for Some Selected Compounds

Name of Compound	Formation Reaction	Standard Enthalpy of Formation, ΔH_f° (kJ/mol of product)
aluminum oxide	$2 \text{Al}_{(s)} + \frac{3}{2}\text{O}_{2(g)} \rightarrow \text{Al}_2\text{O}_{3(s)}$	-1669.8
ammonia	$\frac{1}{2}\text{N}_{2(g)} + \frac{3}{2}\text{H}_{2(g)} \rightarrow \text{NH}_{3(g)}$	-46.1
carbon dioxide	$\text{C}_{(s)} + \text{O}_{2(g)} \rightarrow \text{CO}_{2(g)}$	-393.5
carbon monoxide	$\text{C}_{(s)} + \frac{1}{2}\text{O}_{2(g)} \rightarrow \text{CO}_{(g)}$	-110.5
copper(I) oxide	$\text{Cu}_{(s)} + \frac{1}{2}\text{O}_{2(g)} \rightarrow \text{CuO}_{(s)}$	-156
iron(III) oxide	$2 \text{Fe}_{(s)} + \frac{3}{2}\text{O}_{2(g)} \rightarrow \text{Fe}_2\text{O}_{3(s)}$	-822.2
magnesium oxide	$\text{Mg}_{(s)} + \frac{1}{2}\text{O}_{2(g)} \rightarrow \text{MgO}_{(s)}$	-602
methane	$\text{C}_{(s)} + 2 \text{H}_{2(g)} \rightarrow \text{CH}_{4(g)}$	-74.8
nitrogen monoxide	$\frac{1}{2}\text{N}_{2(g)} + \frac{1}{2}\text{O}_{2(g)} \rightarrow \text{NO}_{(g)}$	+90.
nitrogen dioxide	$\frac{1}{2}\text{N}_{2(g)} + \text{O}_{2(g)} \rightarrow \text{NO}_{2(g)}$	+34
sodium chloride	$\text{Na}_{(s)} + \frac{1}{2}\text{Cl}_{2(g)} \rightarrow \text{NaCl}_{(s)}$	-411
sulfur dioxide	$\text{S}_{(s)} + \text{O}_{2(g)} \rightarrow \text{SO}_{2(g)}$	-297
sulfur trioxide	$\text{S}_{(s)} + \frac{3}{2}\text{O}_{2(g)} \rightarrow \text{SO}_{3(g)}$	-393.2
water (gaseous)	$\text{H}_{2(g)} + \frac{1}{2}\text{O}_{2(g)} \rightarrow \text{H}_2\text{O}_{(g)}$	-241.8
water (liquid)	$\text{H}_{2(g)} + \frac{1}{2}\text{O}_{2(g)} \rightarrow \text{H}_2\text{O}_{(l)}$	-285.8

Consider the following equation:

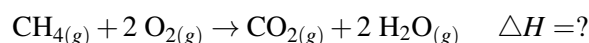

From the table of standard heats of formation, we know that:

$$\Delta H_f(\text{CH}_{4(g)}) = -74.8 \text{ kJ/mol}$$

$$\Delta H_f(\text{O}_{2(g)}) = 0 \text{ kJ/mol}$$

(Note: all elements in their natural state have a $\Delta H_f = 0 \text{ kJ/mol}$)

$$\Delta H_f(\text{CO}_{2(g)}) = -393.5 \text{ kJ/mol}$$

$$\Delta H_f(\text{H}_2\text{O}_{(g)}) = -241.8 \text{ kJ/mol}$$

We also know that $\Delta H_{\text{rxn}} = \Delta H_{\text{products}} - \Delta H_{\text{reactants}}$

Therefore, for this reaction:

$$\Delta H_{\text{rxn}} = [\Delta H_f(\text{CO}_{2(g)}) + 2\Delta H_f(\text{H}_2\text{O}_{(g)})] - [\Delta H_f(\text{CH}_{4(g)}) + 2\Delta H_f(\text{O}_{2(g)})]$$

Note that the heat of formation for gaseous water and that for oxygen gas are to be multiplied by two because there are two moles of oxygen gas and two moles of gaseous water in the combustion reaction.

We can now calculate the value for ΔH_{rxn} because we have all of the required values for $\Delta H_{\text{products}}$ and $\Delta H_{\text{reactants}}$.

$$\begin{aligned}\Delta H_{\text{rxn}} &= [(-393.5 \text{ kJ/mol}) + (2)(-241.8 \text{ kJ/mol})] - [(-74.8 \text{ kJ/mol}) + (2)(0 \text{ kJ/mol})] \\ \Delta H_{\text{rxn}} &= [-877.1 \text{ kJ/mol}] - [-74.8 \text{ kJ/mol}] \\ \Delta H_{\text{rxn}} &= -802.3 \text{ kJ/mol}\end{aligned}$$

Rewriting the equation we see:

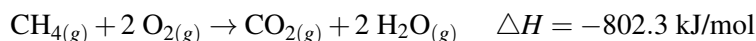

Example:

Calculate the value of ΔH_{rxn} for the following reaction.

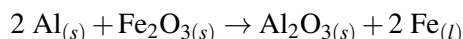

Solution:

From the table of standard heats of formation we know that:

$$\begin{aligned}\Delta H_f(\text{Al}(s)) &= 0 \text{ kJ/mol} \\ (\text{Note: all elements in their natural state have a } \Delta H_f &= 0 \text{ kJ/mol}) \\ \Delta H_f(\text{Fe}_2\text{O}_3(s)) &= -822.2 \text{ kJ/mol} \\ \Delta H_f(\text{Al}_2\text{O}_3(s)) &= -1669.8 \text{ kJ/mol} \\ \Delta H_f(\text{Fe}(l)) &= -12.4 \text{ kJ/mol}\end{aligned}$$

Therefore, for this reaction:

$$\begin{aligned}\Delta H_{\text{rxn}} &= [\Delta H_f(\text{Al}_2\text{O}_3(s)) + 2 \times \Delta H_f(\text{Fe}(l))] - [2 \times \Delta H_f(\text{Al}(s)) + \Delta H_f(\text{Fe}_2\text{O}_3(s))] \\ \Delta H_{\text{rxn}} &= [-1669.8 \text{ kJ/mol} + (2)(-12.4 \text{ kJ/mol})] - [(2)(0 \text{ kJ/mol}) + (-822.2 \text{ kJ/mol})] \\ \Delta H_{\text{rxn}} &= [-1694.6 \text{ kJ/mol}] - [-822.2 \text{ kJ/mol}] \\ \Delta H_{\text{rxn}} &= -872.4 \text{ kJ/mol}\end{aligned}$$

Rewriting the equation:

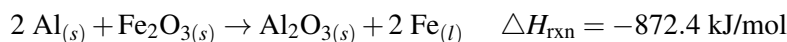

Hess's Law of Heat Summation

The first method shown for finding ΔH_{rxn} is to subtract the ΔH (reactants) from the ΔH (products). Sometimes, however, this method is not always possible. Compounds may not be easily produced from their elements, so there is not an available value for the ΔH_f . Other times, there may be side reactions happening, and there is a need for a more indirect method for calculating the value of the ΔH_{rxn} . In the middle of the 1800s, Germain Hess developed a method for determining the ΔH_{rxn} indirectly. **Hess's law** states in any series of reactions that start with the same reactants and end with the same products, the net change in energy must be the same. This means that if multiple reactions are combined, the enthalpy change, ΔH , of the combined reaction is equal to the sum of all the individual enthalpy changes. So how does this work? It can be as straight forward as multiplying a reaction by a number or rearranging the reactions. Consider the following example.

Given the following equation:

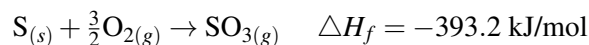

Calculate ΔH for the reaction:

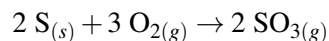

Notice that the second equation is the first equation multiplied by two. Therefore, we can simply multiply the ΔH by the same factor, that is, two.

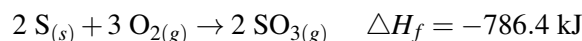

If we were to reverse the direction of a reaction, then the sign of the ΔH must also be reversed. Look at the example below that illustrates this possibility.

Given the following equation:



What is the value of ΔH for the reaction $2 \text{NO}_{2(g)} \rightarrow 2 \text{NO}_{(g)} + \text{O}_{2(g)}$?

Notice when looking at the two equations, the second equation is the reverse of the first equation. Therefore, the ΔH value will change signs (or be multiplied by -1).

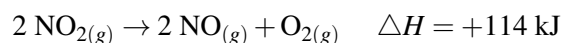

The most useful of Hess's law, and the critical part of his definition, is the ability to add multiple reactions to obtain a final reaction and subsequently add the ΔH 's. Consider the equation below:

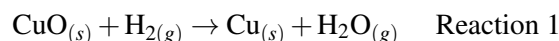

Suppose we wish to know the ΔH for this reaction but necessary ΔH_f values are not available. We do, however, have the following two equations available:



If we add these two equations by the normal addition of equations process, the result is exactly the same as Reaction 1:

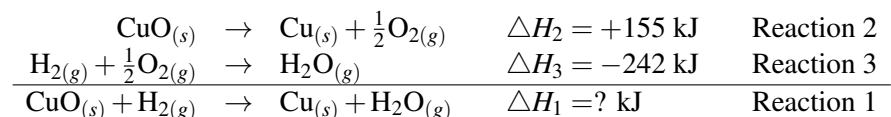

Hess's Law tells us that since Reactions 2 and 3 add to give Reaction 1, the sum of ΔH_2 and ΔH_3 will be equal to ΔH_1 (for Reaction 1). (Note: Since one-half mole of oxygen gas appears on each side of the equation, it cancels out).

It is relatively easy to demonstrate the truth of this statement mathematically. We can express ΔH_1 as the heats of formation of its products minus the heats of formation of its reactants in the normal way.

$$\begin{aligned} \Delta H_1 &= [\Delta H_f(\text{Cu}_{(s)}) + \Delta H_f(\text{H}_2\text{O}_{(g)})] - [\Delta H_f(\text{CuO}_{(s)}) + \Delta H_f(\text{H}_{2(g)})] \\ \Delta H_1 &= \Delta H_f(\text{Cu}_{(s)}) + \Delta H_f(\text{H}_2\text{O}_{(g)}) - \Delta H_f(\text{CuO}_{(s)}) - \Delta H_f(\text{H}_{2(g)}) \end{aligned}$$

We can do the same for ΔH_2 and ΔH_3 and then add the expressions for ΔH_2 and ΔH_3 together.

$$\begin{aligned}\Delta H_2 &= \Delta H_f(\text{Cu}_{(s)}) + \Delta H_f\left(\frac{1}{2}\text{O}_{2(g)}\right) - \Delta H_f(\text{CuO}_{(s)}) \\ \Delta H_3 &= \Delta H_f(\text{H}_2\text{O}_{(g)}) - \Delta H_f(\text{H}_{2(g)}) - \Delta H_f\left(\frac{1}{2}\text{O}_{2(g)}\right) \\ \Delta H_2 + \Delta H_3 &= \Delta H_f(\text{Cu}_{(s)}) + \Delta H_f\left(\frac{1}{2}\text{O}_{2(g)}\right) - \Delta H_f(\text{CuO}_{(s)}) + \Delta H_f(\text{H}_2\text{O}_{(g)}) - \Delta H_f(\text{H}_{2(g)}) - \Delta H_f\left(\frac{1}{2}\text{O}_{2(g)}\right)\end{aligned}$$

If you can sort through that mess of symbols, you will see that the heat of formation for one-half mole of oxygen gas is added in one place and subtracted in another place. Therefore, those cancel and can be removed from the equation.

$$\Delta H_2 + \Delta H_3 = \Delta H_f(\text{Cu}_{(s)}) - \Delta H_f(\text{CuO}_{(s)}) + \Delta H_f(\text{H}_2\text{O}_{(g)}) - \Delta H_f(\text{H}_{2(g)})$$

You can see that this is equivalent to the expression for ΔH_1 above. Therefore, ΔH_1 is equal to the sum of ΔH_2 and ΔH_3 .

This video serves a blackboard lecture showing the concepts involved with an example of using Hess's Law (7e): <http://www.youtube.com/watch?v=j4-UrAaAy3M> (9:37).

MEDIA

Click image to the left for more content.

Lesson Summary

- All elements in their natural state have a $\Delta H_f = 0$ kJ/mol.
- Hess's Law states that if multiple reactions are combined, the enthalpy (ΔH) of the combined reaction is equal to the sum of all the individual enthalpies.
- If we were to reverse a reaction, the sign of the ΔH is also reversed.
- If you multiply an equation by a factor, the ΔH is also multiplied by that same factor.

Further Reading / Supplemental Links

For more practice using Hess's law, visit the following website.

- http://proton.csudh.edu/lecture_help/Hesslaw.html

Review Questions

1. Define the Hess's Law and the need to use this method.
2. Draw a potential energy diagram to represent the reaction: $\text{S}_{8(s)} + 8 \text{Cl}_{2(g)} \rightarrow 8 \text{SCl}_{2(s)}$ $\Delta H = -376$ kJ.
3. Which of the following does not have a $\Delta H_f = 0$?

- a. $\text{H}_2\text{O}(l)$
 - b. $\text{O}_2(g)$
 - c. $\text{H}_2(g)$
 - d. $\text{Fe}(s)$
4. Which statement would describe an endothermic reaction?
- a. The potential energy of the reactants is greater than the potential energy of the products.
 - b. The potential energy of the reactants is less than the potential energy of the products.
 - c. Energy is released in the chemical reaction.
 - d. The energy required to break bonds is more than the energy produced when bonds are formed.
5. Given the reaction $2 \text{HCl}(g) \rightarrow \text{H}_2(g) + \text{Cl}_2(g)$, $\Delta H = 185 \text{ kJ}$, what would be the ΔH for the following reaction:
 $\frac{1}{2} \text{H}_2(g) + \frac{1}{2} \text{Cl}_2(g) \rightarrow \text{HCl}(g)$?
- a. 185 kJ
 - b. -185 kJ
 - c. 92.5 kJ
 - d. -92.5 kJ
6. Which of the following reactions represents that for a ΔH_f ?
- a. $4 \text{Fe}(s) + 3 \text{O}_2(g) \rightarrow 2 \text{Fe}_2\text{O}_3(s)$
 - b. $\text{SO}_2(g) + \frac{1}{2} \text{O}_2(g) \rightarrow \text{SO}_3(g)$
 - c. $2 \text{Al}(s) + \frac{3}{2} \text{O}_2(g) \rightarrow \text{Al}_2\text{O}_3(s)$
 - d. $\frac{1}{2} \text{C}_4\text{H}_{10}(g) + \frac{1}{2} \text{H}_2(g) \rightarrow \text{C}_2\text{H}_6(g)$
7. Hydrogen sulfide can mix with carbon dioxide to make a very smelly liquid, carbon disulfide. Given that the enthalpies of formation for $\text{CO}_2(g)$, $\text{H}_2\text{S}(g)$, $\text{CS}_2(l)$, and $\text{H}_2\text{O}(l)$ are -393.5 kJ/mol, -20.6 kJ/mol, 116.7 kJ/mol, and -285.8 kJ/mol, respectively, calculate ΔH_{rxn} .
8. Ethene is a common compound used in the production of plastics for plastic bottles. Calculate the ΔH_{rxn} for ethene: $2 \text{C}(g) + 2 \text{H}_2(g) \rightarrow \text{C}_2\text{H}_4(g)$.

22.3 Spontaneous Processes

Lesson Objectives

The student will:

- define a spontaneous and non-spontaneous reaction.
- identify processes as either spontaneous or non-spontaneous.
- describe how endothermic and exothermic reactions can be spontaneous or non-spontaneous.
- explain the lack of correlation between spontaneity and speed of reaction.

Vocabulary

- non-spontaneous event
- spontaneous event

Introduction

Some events or reactions occur without any outside forces. For example, if you drop a spoonful of sugar into a cup of water, it automatically dissolves. The sugar is said to spontaneously dissolve in water. Rusting of iron can be spontaneous under the right conditions, but to undo this process would not be spontaneous. In this lesson, we will consider spontaneous and non-spontaneous reactions in light of what we just learned with respect to enthalpy.

Change That Occurs Without Outside Assistance

A **spontaneous event (or reaction)** is a change that occurs under a specific set of conditions. A ball rolling down a hill, the water falling down a waterfall, and the dispersion of the smell of a perfume sprayed in a room (expansion of a gas) are all examples of spontaneous events. In comparison, a **non-spontaneous event (or reaction)** would be a change that will not occur under a specific set of conditions. Can you picture a cold cup of hot chocolate on your desk becoming warmer as you sit and listen to your chemistry teacher? Probably not, because an external source of heat would be required to warm up the hot chocolate. For non-spontaneous events, something else outside of the reaction must be done in order to get the event (or reaction) to occur. This might be applying a force to make a ball roll up a hill or to ski up the mountain. Other factors that could drive a reaction could be the addition of heat, addition of a catalyst, or an increase in pressure.

Example:

Which of the following would be considered spontaneous? Which would be considered non-spontaneous? Explain.

1. cooling a cup of hot coffee at room temperature

2. ice melting at room temperature
3. compression of gas to fill a tire
4. water flowing downhill

Solution:

1. Cooling a cup of hot coffee is spontaneous because heat flows spontaneously from a hotter substance to a cooler one.
2. Ice melting is spontaneous above 0°C because above this temperature, water is normally at the liquid state.
3. Compression of gas to fill a tire is non-spontaneous because a pressure has to be applied to a gas in order to compress it.
4. Water flowing downhill is spontaneous because water will always flow down.

Exothermic or Endothermic Can Be Spontaneous

Spontaneous and non-spontaneous reactions can be either endothermic or exothermic. Consider the the endothermic and the exothermic potential energy diagrams shown below.

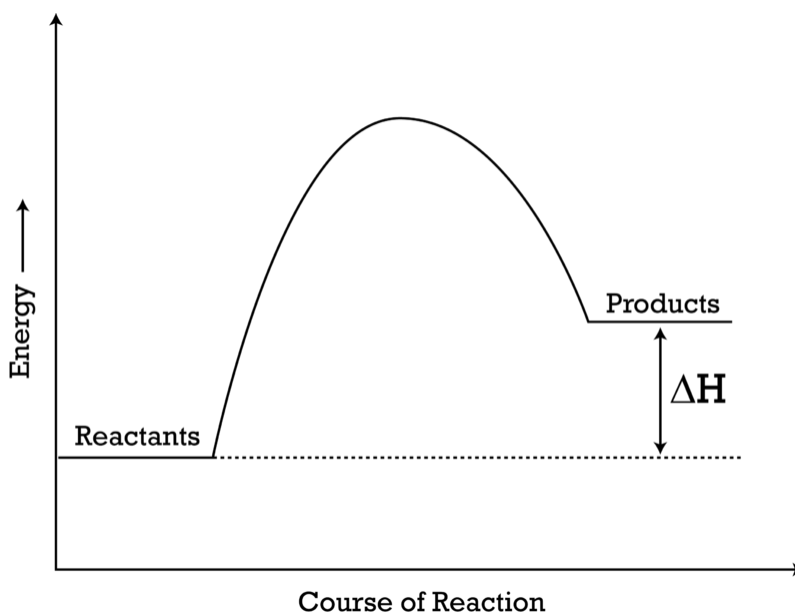
Endothermic Reaction**Exothermic Reaction**

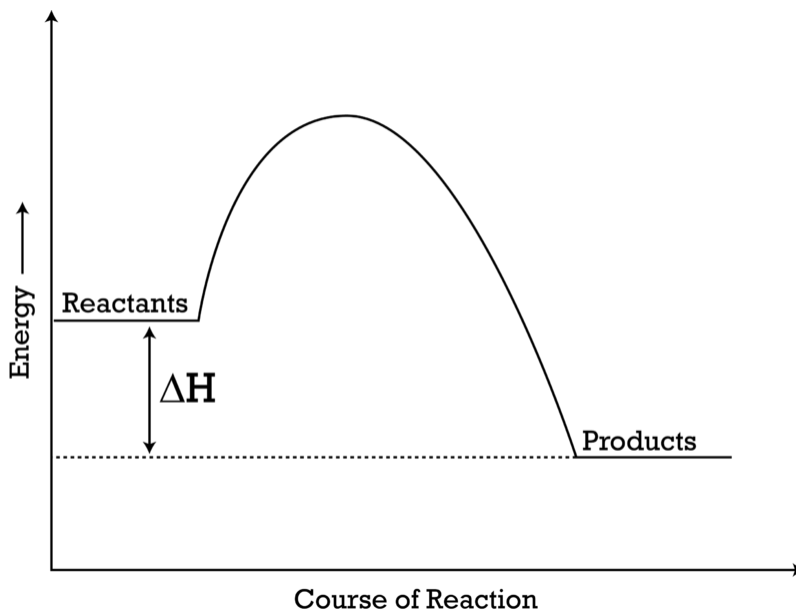

Often but not always, a spontaneous process will be one that will result in a decrease in the energy of a system. Therefore, water will spontaneously flow down a waterfall, a ball will roll down a hill, and gas will expand to fill a container. All of these changes will occur spontaneously, leaving the products (or product state) with less energy than the reactants (or reactant state). Furthermore, if a reaction is spontaneous in one direction, it is non-spontaneous in the opposite direction. For example, a ball rolling down a hill would be a spontaneous event, but a ball rolling up a hill would be non-spontaneous.

Being spontaneous doesn't necessarily mean, however, that the reaction is exothermic. Highly exothermic reactions tend to be spontaneous, but weakly exothermic or endothermic reactions can be spontaneous under the right conditions. In other words, endothermic reactions can be spontaneous just like exothermic reactions can be non-spontaneous. Consider the equation below. This equation represents the phase change of solid water (ice) to liquid water at 25°C.



We know that ice will spontaneously melt above 0°C, and the equation above also indicates the phase change is spontaneous. Now consider the equation for combustion below. Combustion is an example of a spontaneous, exothermic reaction.

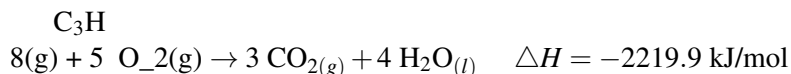

Therefore, spontaneity does not dictate whether a reaction is endothermic or exothermic. A spontaneous reaction is more likely to be exothermic but can be endothermic. Non-spontaneous reactions are more likely to be endothermic but can be exothermic. The deciding factor for these systems is the temperature.

Thermodynamics and Kinetics

A spontaneous process is all about the initial and final states. Reactions are considered spontaneous if, given the necessary activation energy, reactants form the products without any external forces. Therefore, an ice cube will melt, an iron nail will rust in the presence of oxygen dissolved water, and a sparkler will burn. Some of these reactions are fast, and some are slow. The oxidation of iron, for example, is slow. In comparison, after the sparkler is lit, the

reaction from start to finish is quite fast. Regardless of the speed of the reaction, they are both still spontaneous reactions. The rate of these reactions is the study of chemical kinetics; the spontaneity of a reaction is the study of thermodynamics. Whether the reaction occurs quickly or slowly has little to do with the reaction being spontaneous. A spontaneous reaction only means that it occurs without any continuous outside support.

Lesson Summary

- A spontaneous event (or reaction) is a change that occurs under a specific set of conditions and without any continuous external support.
- A non-spontaneous event (or reaction) would then be a change that will not occur under a specific set of conditions.
- Being spontaneous does not indicate how fast a reaction occurs or if the reaction is exothermic or endothermic.

Further Reading / Supplemental Links

The *learner.org* website allows users to view streaming videos of the Annenberg series of chemistry videos. You are required to register before you can watch the videos but there is no charge. The website has one video that relates to this lesson called “The Driving Forces.”

- <http://learner.org/resources/series61.html>

Review Questions

1. Distinguish between spontaneous and non-spontaneous reactions.
2. Why are spontaneous reactions usually exothermic (but still can be endothermic)?
3. Which of the following processes would be spontaneous?
 - a. dissolving table salt
 - b. climbing Mt. Everest
 - c. separating helium from nitrogen in a mixture of gases
 - d. none of these are spontaneous
4. Which of the following processes would be non-spontaneous?
 - a. iron rusting in air
 - b. ice melting at 10°C
 - c. a wild fire
 - d. the reaction of CO₂ and H₂O
5. Which of the following reactions are spontaneous?

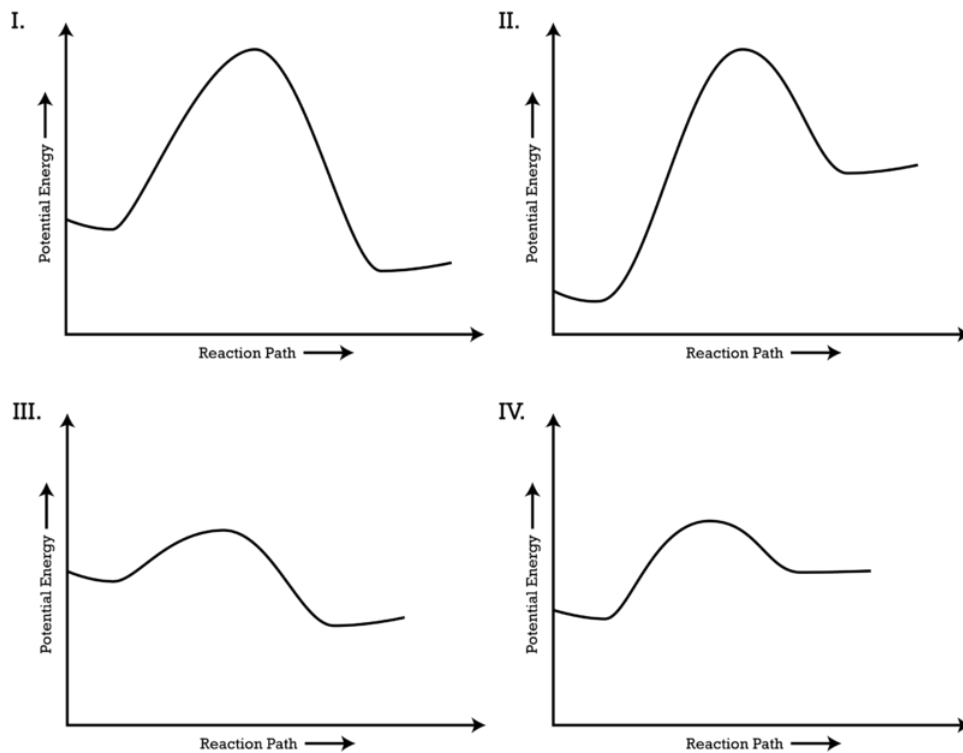

- a. I and II
- b. I and III
- c. II and IV
- d. Not enough information is given

6. If a reaction is spontaneous and fast, draw a likely potential energy diagram.

22.4 Entropy

Lesson Objectives

The student will:

- define entropy.
- calculate entropy.
- relate entropy to the tendency toward spontaneity.
- describe the factors that affect the increase or decrease in disorder.

Vocabulary

- entropy

Introduction

In this section of the chapter, we explore the disorder of a system. Look at the diagrams of the two chessboards below.

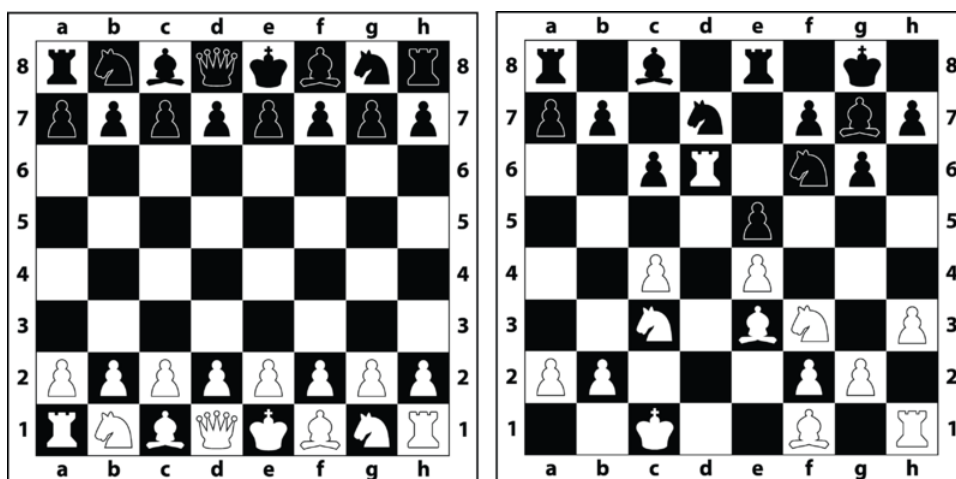

At the start of a chess game, the chess pieces are all in place and orderly. After the game begins and you and your opponent have been playing for a while, there is more disorder in the positions of the chess pieces.

The same is true for reactions. Some reactions start out with more order than they end up with on the product side. Other reactions begin with a higher amount of disorder, but the products that form have a high amount of order. The study of the disorder of reactions is known as entropy and is the focus of this lesson.

The second law of thermodynamics states that the total entropy of the universe is continually increasing.

The Measure of the Disorder of a System

Entropy (S) is a measure of the disorder or randomness of a system. If there is more disorder in the system, there is more entropy. What does it mean to increase disorder? Consider the figure below.

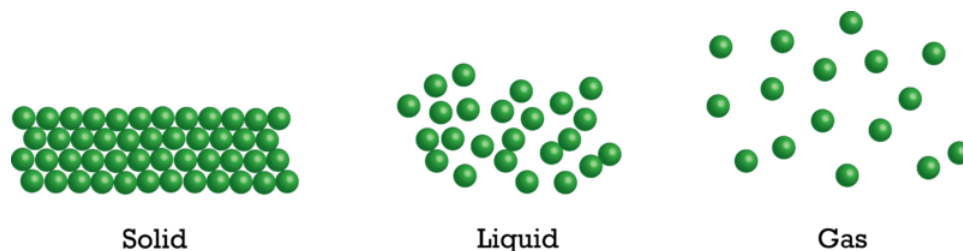

The molecules in the gas have little or no attraction between the molecules, which means that there are many more possibilities of where each molecule can be found in space. As a result, the gas molecules have greater disorganization. Liquids have some disorganization. Although there is some attraction between the molecules, they can move somewhat more freely. In solids where there is great attraction between the molecules, there is much less possibility for the molecules to be unorganized. Therefore, $S_{\text{gas}} > S_{\text{liquid}} > S_{\text{solid}}$ because there is more disorder or randomness in a gas than there is in a liquid than in a solid.

The most commonly used example to illustrate disorder is to use a deck of playing cards. If you buy a brand new deck of playing cards, all of the cards are in four suits lined up from Ace to King. This means the deck of cards has order. If, however, you were to take your new deck of cards and toss them up into the air, you now have disorder. If you pick up the mess and put the deck of cards back into order, this means you will once again put the cards into four suits lined up from Ace to King.

For a system, the change in entropy, ΔS , is measured by finding the difference between the entropy of the products and of the reactants, similar to how the change in enthalpy is calculated. Standard entropies are determined in the lab and published in standard entropy tables in the same manner as standard enthalpies. In fact, both standard enthalpy and standard entropy are often listed in the same table (**Table 22.2**).

TABLE 22.2: Standard Enthalpy of Formation and Standard Entropies for Some Selected Compounds

Name of Compound	Formation Reaction	Standard Enthalpy of Formation, ΔH_f° (kJ/mol of product)	Standard Entropy, S° , (J/mol \cdot °C)
aluminum oxide	$2 \text{Al}_{(s)} + \frac{3}{2} \text{O}_{2(g)} \rightarrow \text{Al}_2\text{O}_{3(s)}$	-1669.8	+51
ammonia	$\frac{1}{2} \text{N}_{2(g)} + \frac{3}{2} \text{H}_{2(g)} \rightarrow \text{NH}_{3(g)}$	-46.1	+193
carbon dioxide	$\text{C}_{(s)} + \text{O}_{2(g)} \rightarrow \text{CO}_{2(g)}$	-393.5	+214
carbon monoxide	$\text{C}_{(s)} + \frac{1}{2} \text{O}_{2(g)} \rightarrow \text{CO}_{(g)}$	-110.5	+198
copper(I) oxide	$\text{Cu}_{(s)} + \frac{1}{2} \text{O}_{2(g)} \rightarrow \text{CuO}_{(s)}$	-156	+43
iron(III) oxide	$\text{Fe}_{(s)} + \frac{3}{2} \text{O}_{2(g)} \rightarrow \text{Fe}_2\text{O}_{3(s)}$	-822.2	+90.
magnesium oxide	$\text{Mg}_{(s)} + \frac{1}{2} \text{O}_{2(g)} \rightarrow \text{MgO}_{(s)}$	-602	+27
methane	$\text{C}_{(s)} + 2 \text{H}_{2(g)} \rightarrow \text{CH}_{4(g)}$	-74.8	+188
nitrogen monoxide	$\frac{1}{2} \text{N}_{2(g)} + \frac{1}{2} \text{O}_{2(g)} \rightarrow \text{NO}_{(g)}$	+90.	+211
nitrogen dioxide	$\frac{1}{2} \text{N}_{2(g)} + \text{O}_{2(g)} \rightarrow \text{NO}_{2(g)}$	+34	+240
sodium chloride	$\text{Na}_{(s)} + \frac{1}{2} \text{Cl}_{2(g)} \rightarrow \text{NaCl}_{(s)}$	-411	+72
sulfur dioxide	$\text{S}_{(s)} + \text{O}_{2(g)} \rightarrow \text{SO}_{2(g)}$	-297	+248
sulfur trioxide	$\text{S}_{(s)} + \frac{3}{2} \text{O}_{2(g)} \rightarrow \text{SO}_{3(g)}$	-393.2	+257

TABLE 22.2: (continued)

Name of Compound	Formation Reaction	Standard Enthalpy of Formation, ΔH_f° (kJ/mol of product)	Standard Entropy, S° , (J/mol $\cdot^\circ\text{C}$)
water (gaseous)	$\text{H}_2(\text{g}) + \frac{1}{2}\text{O}_2(\text{g}) \rightarrow \text{H}_2\text{O}(\text{g})$	-241.8	+189
water (liquid)	$\text{H}_2(\text{g}) + \frac{1}{2}\text{O}_2(\text{g}) \rightarrow \text{H}_2\text{O}(\text{l})$	-285.8	+70.

It is important to note in the above table that the units for enthalpy of formation and entropy are **not** the same. Enthalpies of formation in the table have energy units in kilojoules while entropy has energy units in joules. If these values are entered into a formula together, one of them must be converted so that all energy units are the same.

Therefore, the change in entropy for a reaction (ΔS_{rxn}) can be found using the following equation:

$$\Delta S_{\text{rxn}} = S_{\text{products}} - S_{\text{reactants}}$$

Example:

Given the following data, calculate the ΔS_{rxn} for the following reaction:



Given that $S(\text{NH}_3(\text{g})) = 111.3 \text{ J/K}\cdot\text{mol}$, $S(\text{HCl}(\text{g})) = 267.3 \text{ J/K}\cdot\text{mol}$, $S(\text{NH}_4\text{Cl}(\text{s})) = 94.56 \text{ J/K}\cdot\text{mol}$.

Solution:

$$\begin{aligned} \Delta S_{\text{rxn}} &= S_{\text{products}} - S_{\text{reactants}} \\ \Delta S_{\text{rxn}} &= S(\text{NH}_4\text{Cl}(\text{s})) - [S(\text{NH}_3(\text{g})) + S(\text{HCl}(\text{g}))] \\ \Delta S_{\text{rxn}} &= (94.56 \text{ J/K}\cdot\text{mol}) - (193 \text{ J/K}\cdot\text{mol} + 187 \text{ J/K}\cdot\text{mol}) \\ \Delta S_{\text{rxn}} &= (94.56 \text{ J/K}\cdot\text{mol}) - (380 \text{ J/K}\cdot\text{mol}) \\ \Delta S_{\text{rxn}} &= -285 \text{ J/K}\cdot\text{mol} \end{aligned}$$

Therefore,

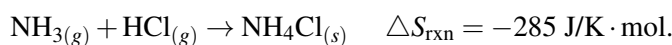

What does it mean when ΔS_{rxn} is negative? In this system, two gases are coming together to form a solid, and the value of ΔS_{rxn} is negative. We can make a conclusion that if the order of the system increases, then the change in entropy value (ΔS) will be negative. In other words, if a system goes from a state of high disorder (two moles of gas) to a state of low disorder (one mole of solid), the entropy change is negative. Let's try another example.

Example:

For the reaction $\text{CaCO}_3(\text{s}) \rightarrow \text{CaO}(\text{s}) + \text{CO}_2(\text{g})$ at 25°C , calculate the value of ΔS_{rxn} .

Given: $S(\text{CaCO}_3(\text{s})) = 92.9 \text{ J/K}\cdot\text{mol}$; $S(\text{CaO}(\text{s})) = 39.8 \text{ J/K}\cdot\text{mol}$; and $S(\text{CO}_2(\text{g})) = 213.6 \text{ J/K}\cdot\text{mol}$.

Solution:

$$\begin{aligned} \Delta S_{\text{rxn}} &= S_{\text{products}} - S_{\text{reactants}} \\ \Delta S_{\text{rxn}} &= [S(\text{CaO}(\text{s})) + S(\text{CO}_2(\text{g}))] - S(\text{CaCO}_3(\text{s})) \\ \Delta S_{\text{rxn}} &= [39.8 \text{ J/K}\cdot\text{mol} + 213.6 \text{ J/K}\cdot\text{mol}] - (92.9 \text{ J/K}\cdot\text{mol}) \\ \Delta S_{\text{rxn}} &= (253.4 \text{ J/K}\cdot\text{mol}) - (92.9 \text{ J/K}\cdot\text{mol}) \\ \Delta S_{\text{rxn}} &= 160.5 \text{ J/K}\cdot\text{mol} \end{aligned}$$

Therefore:

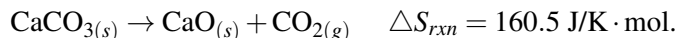

In this problem, the system becomes more disordered since a solid and a gas are the products. The value of the entropy change for the reaction is positive. We can conclude that if the disorder of the reaction increases, then the change in entropy value (ΔS) will be positive. In other words, if a system goes from a state of low disorder to a state of high disorder, the entropy change is positive.

Entropy and Spontaneous Reactions

A reaction will tend to be spontaneous if the reaction moves from a state of low disorder to a state of high disorder. Look at the example below.

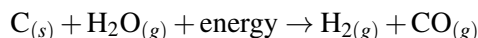

In the equation above, the enthalpy is positive ($\Delta H > 0$). We also know that in the reaction there are two moles of reactants (one of which is a solid) and two moles of products (both of which are gases). Gases have the highest entropies because they have higher disorder than solids or liquids. Therefore this system is one in which moves from a state of low disorder to a state of high disorder. It will tend to be spontaneous. Chemical reactions are driven by the combination of a tendency toward minimum enthalpy (lowest potential energy) and a tendency toward maximum entropy (greatest disorder).

Generalizations for Determining Entropy

Less Organized Phases Contain More Entropy

There are a number of factors that affect the disorder of a system. For instance, when a liquid is formed from a solid or a gas is formed from a liquid, the disorder increases.

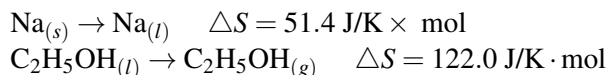

We can also predict that disorder increases when a solid or liquid dissolves in water. The equation below shows solid ammonium chloride dissolving in water. Notice the value of ΔS is positive, indicating the increase in disorder. Entropy increases in this system since the particles are no longer held in place by their electrostatic attractions and are able to move more freely in solution.

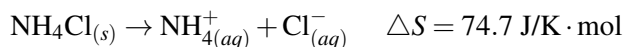

The system therefore increases in disorder, and the entropy is positive. A gas, however, decreases in disorder when it is dissolved in water. The gas molecules have less possible positions. As a result, the disorder decreases and the sign of ΔS would be negative.

Generally, large molecules have a larger entropy than smaller molecules of simpler structures. For example, when we consider methane (CH_4), ethane (C_2H_6), and propane (C_3H_8), we can see that the relationships between their entropies will be that $S_{\text{propane}} > S_{\text{ethane}} > S_{\text{methane}}$. Propane, with more atoms, has more possibilities of rotating and twisting around than ethane and therefore greater entropy.

Increase in Number of Particles Increases Entropy

The equation below represents water being produced from its elements.

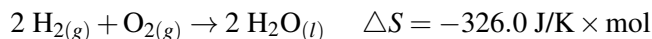

Notice that there are three moles of reactants combining to produce two moles of products. With three moles of gas reactants, the higher entropy is on the reactant side of the chemical equation. The negative value of entropy means the disorder for the system is decreasing. Since the number of particles is decreasing, the particles are going from a gas state to a liquid state, and the disorder is decreasing, $\Delta S \leq 0$.

For the reaction below, the reverse is happening.

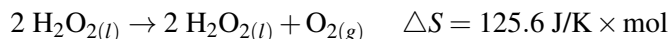

In the equation above, there are two moles of reactant forming three moles of products. Looking at this equation, we see that these two moles of reactant are in the liquid state and that they form products in both the liquid and gas state. An increase in the number of particles and the formation of the gas product means an increase in disorder. Therefore, $\Delta S > 0$. The driving force for this reaction is the oxygen gas being produced.

Example:

Predict whether the entropy will be positive or negative for each of the following:

1. $\text{Br}_{2(g)} \rightarrow \text{Br}_{2(l)}$
2. $\text{Ca}(\text{OH})_{2(s)} \rightarrow \text{Ca}^{2+}_{(aq)} + 2 \text{OH}^{-}_{(aq)}$
3. $\text{CO}_{(g)} + 3 \text{H}_{2(g)} \rightarrow \text{CH}_{4(g)} + \text{H}_2\text{O}_{(g)}$

Solution:

1. Going from a gas to a liquid decreases the disorder of the system, therefore $\Delta S < 0$.
2. Disorder increases when a solid or liquid dissolves in water, therefore $\Delta S > 0$.
3. There are four moles of reactants forming two moles of products. A decrease in the number of particles means a decrease in disorder and therefore $\Delta S < 0$.

Higher Temperature Favors More Entropy

When the temperature of a substance is increased, the molecules have greater average kinetic energy and therefore move around with greater velocity. The greater velocity of the particles means they collide more often and with greater force. The greater force of the collisions cause the molecules to spread further apart. Consequently, increasing the temperature of a system favors the tendency toward greater randomness or maximum entropy.

Lesson Summary

- Entropy (S) is a measure of the disorder of a system. If the order of the reaction increases, then the change in entropy value (ΔS) will be negative. If the order of the reaction decreases, then the change in entropy value (ΔS) will be positive.
- A system that goes from a state of low disorder to a state of high disorder will tend to be spontaneous. The disorder of a system increases if a liquid is formed from a solid, a gas is formed from a liquid, and when a solid or liquid dissolves in water.
- A gas decreases in disorder when it dissolved in water.

Review Questions

- Define entropy.
- Give an everyday example of entropy.
- Which of the following examples will result in an increase in entropy?

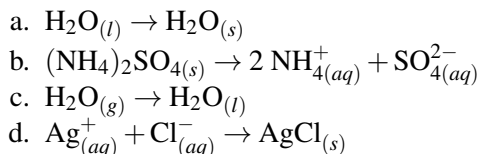

- Which of the following would have the greatest entropy?

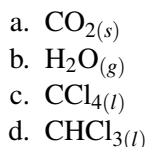

- From the following equations, select those that tend to be spontaneous.

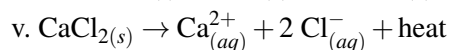
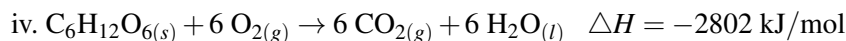
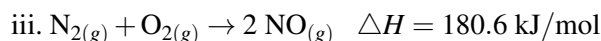
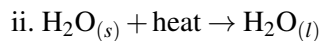
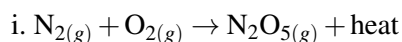

- i, ii, and v
- i and iii
- iii and iv
- i, iv, and v

- Calculate the entropy of the following reactions. Use the data from **Table 22.3**.

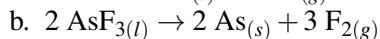
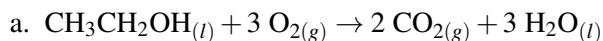
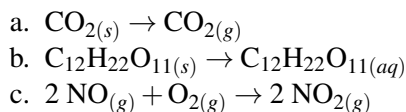

TABLE 22.3:

Compound	ΔS	Compound	ΔS
$\text{CH}_3\text{CH}_2\text{OH}(l)$	$213. \text{ J/K} \times \text{ mol}$	$\text{As}(s)$	$35.1 \text{ J/K} \times \text{ mol}$
$\text{O}_2(g)$	$69.9 \text{ J/K} \times \text{ mol}$	$\text{F}_2(g)$	$202.7 \text{ J/K} \times \text{ mol}$
$\text{CO}_2(g)$	$160.7 \text{ J/K} \times \text{ mol}$	$\text{AsF}_3(l)$	$181.2 \text{ J/K} \times \text{ mol}$
$\text{H}_2\text{O}(l)$	$205.0 \text{ J/K} \times \text{ mol}$		

- Predict whether the entropy will be positive or negative for each of the following:



22.5 Gibbs Free Energy

Lesson Objectives

The student will:

- define Gibbs free energy.
- calculate Gibbs free energy given the enthalpy and entropy.
- use Gibbs free energy to predict spontaneity.

Vocabulary

- Gibbs free energy

Introduction

In the latter part of the 1800s, a Yale physics professor named J. Willard Gibbs published a paper that related the enthalpy of a system to its entropy. It is this relationship, according to Gibbs, that would allow chemists to determine the spontaneity of the system at a specific temperature. The relationship is known as free energy. In this final lesson of the chapter, we will explore Gibbs free energy.

Gibbs Free Energy

Previously we have said that a system tended to be spontaneous if the enthalpy decreased or the entropy increased. However, there are systems that are spontaneous that do not follow that pattern. For instance, ice melts at room temperature. In this case, both the entropy and enthalpy increases. How do we know which will dominate a change? **Gibbs free energy** is defined as the maximum energy available to do useful work and can be determined by the combined effect of the change in the enthalpy of the system and change in the entropy of the reaction measured at a specific temperature.

Gibbs Free Energy Equation

The definition of free energy is shown below.

$$G = H - TS$$

where H is the heat content (enthalpy) of a substance, S is its entropy, and T is the Kelvin temperature. However, since the only way we can know these values is to determine the change that takes place, the equation below is more useful, assuming that the temperature does not change.

$$\Delta G = \Delta H - T\Delta S$$

This equation tells us that the change in free energy for an equation is equal to the change in enthalpy minus the change in entropy times the Kelvin temperature. The free energy available is the energy from the change in enthalpy of the bonds less the amount $T\Delta S$. Or to look at it another way, the higher the temperature, the more the disorder, and the less available the energy becomes.

For Gibbs free energy, a spontaneous change is one where ΔG is negative. If a change takes place at low temperature and involves little change in entropy, $T\Delta S$ will be negligible and ΔG will be spontaneous for an exothermic change ($-\Delta H$). Combustion is a good example and is shown below.



For this reaction, $\Delta H = -5315 \text{ kJ}$ while $\Delta S = 312 \text{ J/K}$, so ΔG will definitely be negative. All combustion reactions are spontaneous at room temperature.

For highly endothermic changes (high positive ΔH), ΔG can only be negative (that is spontaneous) if $T\Delta S$ is large. This means that either the temperature is high or there is a large increase in entropy. An example of this is when solid carbon reacts with water:



ΔS is positive because there is greater order in the solid carbon, which is being converted to the disorder of a gas. The temperature must be high for this reaction to occur (1170 K or higher). In fact, the reaction will stop or even reverse if the temperature decreases. Both conditions are met for ΔG to be negative for this endothermic reaction due to the increase in entropy and the high temperature.

Example:

In the production of ammonia at 25°C , the entropy was found to be $-198.0 \text{ J/K} \cdot \text{mol}$. Calculate the Gibbs free energy for the production of ammonia.

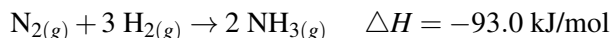

Solution:

$$\Delta H = -93.0 \text{ kJ/mol}$$

$$T = 25^\circ\text{C} + 273.15 = 298.15 \text{ K}$$

$$\Delta S = -198.0 \text{ J/K} \cdot \text{mol} = -0.198 \text{ kJ/K} \cdot \text{mol}$$

$$\Delta G = \Delta H - T\Delta S$$

$$\Delta G = (-93.0 \text{ kJ/mol}) - (298.15 \text{ K})(-0.198 \text{ kJ/K} \cdot \text{mol})$$

$$\Delta G = (-93.0 \text{ kJ/mol}) - (-59.0 \text{ kJ/mol}) = -34.0 \text{ kJ/mol}$$

This video shows an example of how to plug values into Gibbs Free Energy equation (7f): <http://www.youtube.com/watch?v=ECjH1ErqzRU> (3:14).

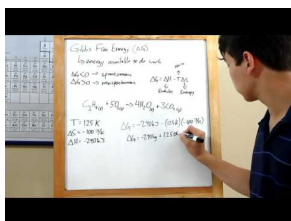

MEDIA

Click image to the left for more content.

The Sign of ΔG and Spontaneity

The sign of ΔG indicates spontaneity. If the sign of ΔG is positive, the reaction is non-spontaneous; if ΔG is negative, the reaction is spontaneous. If ΔG is zero, the reaction is at equilibrium. In the production of ammonia, ΔG was found to be -34.0 kJ/mol at 25°C or 298.15 K. Therefore, at this temperature the production of ammonia is a spontaneous process. What would happen if the temperature were increased?

Example:

Calculate the Gibbs free energy for the production of ammonia at 200°C , the entropy was found to be -198.0 J/K·mol.

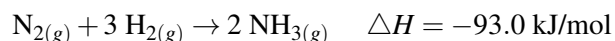

Solution:

$$\Delta H = -93.0 \text{ kJ/mol}$$

$$T = 200^\circ\text{C} + 273.15 = 473.15 \text{ K}$$

$$\Delta S = -198.0 \text{ J/K} \cdot \text{mol} = -0.198 \text{ kJ/K} \cdot \text{mol}$$

$$\Delta G = \Delta H - T\Delta S$$

$$\Delta G = (-93.0 \text{ kJ/mol}) - (473.15 \text{ K})(-0.198 \text{ kJ/K} \cdot \text{mol})$$

$$\Delta G = (-93.0 \text{ kJ/mol}) - (-93.7 \text{ kJ/mol}) = 0.7 \text{ kJ/mol}$$

At 200°C , ΔG is positive, so the reaction is now non-spontaneous. Gibbs free energy is temperature dependent. At high temperatures, some systems that are spontaneous will become non-spontaneous (as is the case with $\text{NH}_{3(g)}$ formation), and some systems that are non-spontaneous will become spontaneous. **Table 22.4** summarizes the conditions that relate ΔH , ΔS , ΔG , and temperature to spontaneity.

TABLE 22.4: Summary for Gibbs Free Energy

ΔH	ΔS	ΔG	Spontaneity
Positive	Positive	Positive at low temperatures Negative at high temperatures	Spontaneous at high temperatures
Negative	Positive	Negative	Spontaneous at all temperatures
Negative	Negative	Negative at low temperatures Positive at high temperatures	Spontaneous at low temperatures
Positive	Negative	Positive	Non-spontaneous at all temps

Example:

Calculate ΔG for the reaction $\text{Cu}_{(s)} + \text{H}_2\text{O}_{(g)} \rightarrow \text{CuO}_{(s)} + \text{H}_2_{(g)}$ when $\Delta H = 84.5$ kJ/mol, $\Delta S = -48.7$ J/K·mol, and $T = 150^\circ\text{C}$.

Is the reaction spontaneous or non-spontaneous at 150°C ?

Solution:

$$\Delta H = 84.5 \text{ kJ/mol}$$

$$T = 150^\circ\text{C} + 273.15 = 423.15 \text{ K}$$

$$\begin{aligned}\Delta S &= -48.7 \text{ kJ/K} \cdot \text{mol} = -0.0487 \text{ kJ/K} \cdot \text{mol} \\ \Delta G &= \Delta H - T\Delta S \\ \Delta G &= (84.5 \text{ kJ/mol}) - (423.15 \text{ K})(-0.0487 \text{ kJ/K} \cdot \text{mol}) \\ \Delta G &= (84.5 \text{ kJ/mol}) - (-20.6 \text{ kJ/mol}) = 105.1 \text{ kJ/mol}\end{aligned}$$

ΔG is positive so the reaction is non-spontaneous. From looking at **Table 22.4**, ΔH is positive and ΔS is negative, so ΔG will always be positive and non-spontaneous.

A blackboard example of using Gibbs free energy equation to determine whether a reaction is spontaneous (**7f**) is available at <http://www.youtube.com/watch?v=sG1ZAdYi13A> (9:57).

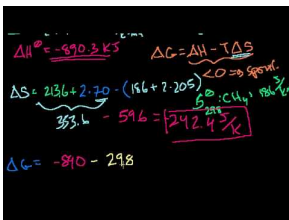

MEDIA

Click image to the left for more content.

Lesson Summary

- Gibbs free energy equation: $\Delta G = \Delta H - T\Delta S$.
- The sign of ΔG indicates spontaneity or non-spontaneity. If the sign of ΔG is positive, the reaction is non-spontaneous; if ΔG is negative, the reaction is spontaneous; if ΔG is zero, the reaction is at equilibrium.

Further Reading / Supplemental Links

The *learner.org* website allows users to view streaming videos of the Annenberg series of chemistry videos. You are required to register before you can watch the videos but there is no charge. The website has one video that relates to this lesson called “The Driving Forces.”

- http://www.learner.org/vod/vod_window.html?pid=805

Review Questions

1. Define Gibbs free energy.
2. Summarize the conditions of spontaneity according to Gibbs free energy equation.
3. For the reaction $\text{C}_2\text{H}_5\text{OH}(l) \rightarrow \text{C}_2\text{H}_5\text{OH}(g)$, $\Delta S = 122.0 \text{ J/K} \times \text{mol}$ and $\Delta H = 42.59 \text{ kJ/mol}$ at 25°C . Which of the following statements is true?
 - a. The reaction will always be spontaneous.
 - b. The reaction will always be non-spontaneous.
 - c. The reaction will be spontaneous only at high temperatures.
 - d. The reaction will be spontaneous only at high temperatures.
4. For the reaction $\text{C}_6\text{H}_6(l) + 3 \text{ H}_2(g) \rightarrow \text{C}_6\text{H}_{12}(l)$, $\Delta S = -101.6 \text{ J/K} \times \text{mol}$ and $\Delta H = -205.4 \text{ kJ/mol}$ at 25°C . Which of the following statements is true?

- The reaction will always be spontaneous.
 - The reaction will always be non-spontaneous.
 - The reaction will be spontaneous only at high temperatures.
 - The reaction will be spontaneous only at low temperatures.
5. For the reaction $\text{COCl}_2(g) \rightarrow \text{CO}(g) + \text{Cl}_2(g)$, $\Delta H = 109.6 \text{ kJ/mol}$ and $\Delta S = 137.1 \text{ J/K} \cdot \text{mol}$. What is the value of ΔG at 25.0°C ?
- 68.7 kJ/mol
 - 106 kJ/mol
 - $-3.32 \times 10^3 \text{ kJ/mol}$
 - $-4.08 \times 10^4 \text{ kJ/mol}$
6. Hydrazine, $\text{N}_2\text{H}_4(l)$, has an important use in the space industry as rocket fuel. The preparation of hydrazine is: $\text{N}_2\text{O}(g) + 3 \text{H}_2(g) \rightarrow \text{N}_2\text{H}_4(l) + \text{H}_2\text{O}(l)$ ($\Delta H = -317.0 \text{ kJ}$). If the value of ΔS is $-393.8 \text{ J/K} \cdot \text{mol}$ at 15°C , what is the value of ΔG ?
- $1.132 \times 10^5 \text{ kJ/mol}$
 - $5.590 \times 10^3 \text{ kJ/mol}$
 - -311.1 kJ/mol
 - -203.5 kJ/mol
7. Which of the following regarding reaction spontaneity is true?
- A reaction with a positive ΔS° will always be spontaneous.
 - A reaction with a negative ΔH° will always be spontaneous.
 - A reaction with a positive ΔS° and a negative ΔH° will always be spontaneous.
 - A reaction with a negative ΔS° and a negative ΔH° will always be spontaneous.
 - A reaction with a positive ΔS° and a positive ΔH° will always be spontaneous.
8. For the reaction $\text{CuO}(s) + \text{H}_2(g) \rightarrow \text{Cu}(s) + \text{H}_2\text{O}(g)$, use the data provided in **Table 22.5** to find the values of:
- ΔH
 - ΔS
 - ΔG at 100°C
 - Is the system spontaneous or non-spontaneous?

TABLE 22.5:

	ΔH	ΔS
$\text{CuO}(s)$	-155.2 kJ/mol	$43.5 \text{ J/K} \cdot \text{mol}$
$\text{H}_2(g)$	0 kJ/mol	$131.0 \text{ J/K} \cdot \text{mol}$
$\text{Cu}(s)$	0 kJ/mol	$33.3 \text{ J/K} \cdot \text{mol}$
$\text{H}_2\text{O}(g)$	-241.8 kJ/mol	$188.7 \text{ J/K} \cdot \text{mol}$

All images, unless otherwise stated, are created by the CK-12 Foundation and are under the Creative Commons license CC-BY-NC-SA.

CHAPTER 23**Electrochemistry****Chapter Outline**

- 23.1 ORIGIN OF THE TERM OXIDATION**
 - 23.2 OXIDATION – REDUCTION**
 - 23.3 BALANCING REDOX EQUATIONS USING THE OXIDATION NUMBER METHOD**
 - 23.4 ELECTROLYSIS**
 - 23.5 GALVANIC CELLS**
-

23.1 Origin of the Term Oxidation

Lesson Objectives

The student will:

- define oxidation.

Introduction

Previously, we have used the term “oxidation” in reference to the oxidation state of atoms. For instance, we specified that the oxidation state of an atom in the alkali family is $+1$. This occurs because these atoms always lose one electron to form an ion. In comparison, the oxidation state of an atom in the halogen family is -1 . Again, this is because a halogen atom tends to gain an electron to form its ions. In this chapter, we will re-examine the concept of oxidation in more details.

Vocabulary

- combustion
- phlogiston

Phlogiston

The term **phlogiston** was coined by Georg Stahl in a paper published in 1718. Stahl was expanding on a concept originated by his teacher, Johann Joachim Becher. The phlogiston theory held that all flammable materials contain a substance named phlogiston in addition to the other components of the material. Phlogiston was described as being colorless, tasteless, and odorless. The only way to experience phlogiston was to observe it departing a burning material. The escaping phlogiston could be observed as the smoke and the orange and yellow light that accompanied combustion.

When pieces of wood, paper, or other flammable materials were burned, the residue of the flammable materials weighed less than the original, which seemed to support the theory that some substance was leaving the burning material. Once a substance was completely burned, another supporting observation was that the residue could not be burned further, which suggested the phlogiston was gone. The fact that a material soon stopped burning when it was burned in a closed container was also used to support the theory of phlogiston. The explanation was that the air had a maximum capacity for absorbing phlogiston, and once the air had absorbed the maximum, it could no longer support combustion. For the same reason, the same air from the container would not support the combustion of another material nor would it support life.



The theory of phlogiston was quite widely accepted. When nitrogen was discovered in 1772, it was referred to as phlogisticated air because it would not support combustion nor life, and when oxygen was discovered by Priestly in 1774, it was referred to as de-phlogisticated air because it could accept more phlogiston, that is, support combustion and life.

The first contradictory observation occurred with the combustion of certain metals such as magnesium. Experimenters determined that when magnesium burned, it gained mass even though it was supposed to be losing phlogiston. Some proponents of the phlogiston theory attempted to rationalize the observation with explanations such as metallic phlogiston had “negative mass” or that phlogiston had a buoyancy effect because it was lighter than air. These suggestions were not very convincing and indicated another theory was needed.

Lavoisier and Combustion

The phlogiston theory remained the dominant theory until Antoine Lavoisier (1743-1794) demonstrated that **combustion** was actually a combination of the flammable material with some component of the air. Lavoisier used the work of Joseph Priestley (the discoverer of oxygen) to demonstrate that if *all* the products of combustion (smoke, ash, etc.) were retained by carrying out the combustion in a closed container, then all combustible materials gained mass, not lose mass. Lavoisier also demonstrated that the increase in mass of the combustible material was exactly equal to the loss of mass of the air in the container.

Lavoisier suggested that combustion was the combination of the flammable material with some component of the air – namely oxygen. This theory of combustion was quickly accepted, replacing the phlogiston theory. You should not think that the acceptance and later rejection of the phlogiston theory as some unfortunate flaw in the scientific method. It is, rather, an example of the normal functioning of the scientific method.

Lesson Summary

- The phlogiston theory of combustion suggested that a substance called phlogiston was escaping from the combustible material into the air.
- Lavoisier’s theory of combustion was that the combustible material was combining with some component of the air.
- The theory of combustion replaced the phlogiston theory.

Further Reading / Supplemental Links

This web site offers text material on the demise of the phlogiston theory and some history about some early chemists.

- <http://web.fccj.org/ethall/phlogist/phlogist.htm>

Review Questions

1. What would be the experimental difference between phlogisticated air and de-phlogisticated air?

23.2 Oxidation – Reduction

Lesson Objectives

The student will:

- assign the correct oxidation number to any element in a compound or ion.
- identify the substance being oxidized, the substance being reduced, the oxidizing agent, and the reducing agent in an oxidation-reduction equation.

Vocabulary

- oxidation
- oxidation number
- oxidizing agent
- redox reaction
- reducing agent
- reduction

Introduction

Many important chemical reactions involve the exchange of one or more electrons. The stoichiometric calculations that chemists make on chemical reactions require a balanced equation. The “inspection” method for balancing equations works well and quickly for many reactions, but when a more complex electron exchange is involved, a new method for equation balancing is needed.

Definition of Oxidation and Reduction

After Lavoisier, a substance was said to be oxidized when it reacted with oxygen. A reaction with oxygen was called oxidation. Today, the words “oxidized” and “oxidation” are still used for those situations, but these words have now acquired a much broader, second meaning. The broader sense of **oxidation** is defined as losing electrons. When a substance reacts with oxygen, it almost always loses electrons to the oxygen, so we are simply extending the term oxidation to mean losing electrons, whether it is to oxygen or to any other substance.

The other half of this process, the gaining of electrons, also needs a name. When an atom or an ion gains electrons, the positive charge on the particle is decreased. For example, if a neutral sulfur atom (charge of 0) gains two electrons, its charge becomes -2 , and if an Fe^{3+} ion gains an electron, its charge changes from $+3$ to $+2$. In both cases, the charge on the particle is reduced by the gain of electrons. **Reduction** means the gain of electrons. In chemical systems, oxidation and reduction must occur simultaneously, so the number of electrons during oxidation

must be the same as the number of electrons gained during reduction. In oxidation-reduction reactions, electrons are transferred from one substance to another. Here's an example of an oxidation–reduction reaction:

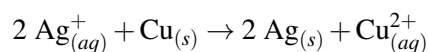

In this reaction, the silver ions are gaining electrons to become silver atoms. Therefore, the silver ions are being reduced. The copper atoms are losing electrons to become copper ions and are being oxidized. Whenever a chemical reaction involves electrons being transferred from one substance to another, the reaction is an oxidation–reduction reaction. An oxidation-reduction reaction can also be referred to as a **redox reaction** for short.

Oxidizing and Reducing Agents

When a substance is oxidized, it loses electrons. In chemical reactions, this requires that another substance take on those electrons and be reduced. Therefore, when a substance undergoes oxidation, it causes another substance to be reduced. The substance that caused another substance to be reduced is called a **reducing agent**. As you can see, the substance undergoing oxidation and the reducing agent are the same substance.

Similarly, when a substance gains electrons, it is reduced. By gaining electrons, it is causing some other substance to give up those electrons. Therefore, by undergoing reduction, the substance is causing another substance to be oxidized and is called an **oxidizing agent**. Again, the substance undergoing reduction and the oxidizing agent are the same substance.

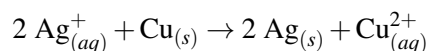

In the oxidation-reduction reaction above, silver ions are being reduced and are the oxidizing agent. Similarly, copper atoms are being oxidized and are the reducing agent. These substances are always on the reactant side of the equation.

Oxidation Numbers

In order to balance oxidation and reduction reaction equations, it is necessary to have a bookkeeping system to keep track of the transferred electrons. The bookkeeping system chemists use to keep track of electrons in oxidation-reduction reactions is called **oxidation numbers**. The assignment of oxidation numbers to all the atoms or ions in a reaction follows a set of rules. For the most part, these rules will have the oxidation number of a particle be the number of electrons the atom has gained or lost from its elemental state. For example, for a Ca^{2+} ion, the calcium ion has clearly lost two electrons from its elemental form, so its oxidation number is +2. Similarly, it is clear that a fluoride ion, F^- , has gained one electron from its elemental state and has an oxidation number of –1.

The first rule for assigning oxidation numbers is for substances in their elemental form. Substances in elemental form have oxidation numbers of zero. It is clear that substances in elemental form have neither gained nor lost any electrons from their elemental state (**Table 23.1**).

TABLE 23.1: Examples of Oxidation Numbers for Substances in Elemental Form

Substance	Oxidation Number
Fe	0
Ag	0
H_2	0
O_2	0

TABLE 23.1: (continued)

Substance	Oxidation Number
Cl ₂	0
S ₈	0

The second rule for assigning oxidation numbers is for monatomic ions. For monatomic ions, the oxidation number is the same as the charge on the ion. Again, it should be apparent that the charge on the ion is an indication of how many electrons have been gained or lost. **Table 23.2** shows examples of oxidation numbers for monatomic ions.

TABLE 23.2: Examples of Oxidation Numbers for Monatomic Ions

Substance	Oxidation Number
Ca ²⁺	+2
Ag ⁺	+1
Fe ³⁺	+3
S ²⁻	-2
F ⁻	-1
Na ⁺	+1

The third rule is for the atoms of family IA, the alkali metals, in compounds. Alkali metals always lose their single valence electron when they combine. Therefore, for IA metals, the oxidation number in compounds is +1 (see **Table 23.3** for examples).

TABLE 23.3: Examples of Oxidation Numbers for Alkali Metals in Compounds

Substance	Oxidation Number for the Alkali Metal
NaCl	+1
Na ₂ S	+1
Na ₂ SO ₄	+1
NaC ₂ H ₃ O ₂	+1
KClO ₄	+1

The fourth rule is for the atoms of family IIA, the alkali earth metals, in compounds. Alkali earth metals always lose both of their valence electrons when they combine chemically, so for IIA metals, the oxidation number in compounds is +2 (see **Table 23.4** for examples).

TABLE 23.4: Examples of Oxidation Numbers for Alkali Earth Metals in Compounds

Substance	Oxidation Number for the Alkali Earth Metal
MgF ₂	+2
Ca(NO ₃) ₂	+2
Mg(OH) ₂	+2
CaO	+2

The fifth rule concerns hydrogen atoms when they are in compounds. In the great majority of compounds that hydrogen forms, it either completely or at least partially loses that electron. In compounds where hydrogen is the more electropositive atom, the oxidation number for hydrogen is +1 (see **Table 23.5** for examples).

TABLE 23.5: (continued)

Substance	Oxidation Number for Hydrogen
-----------	-------------------------------

TABLE 23.5: Examples of Oxidation Numbers for Hydrogen in Compounds

Substance	Oxidation Number for Hydrogen
HF	+1
H ₂ O	+1
HC ₂ H ₃ O ₂	+1
Mg(OH) ₂	+1
CH ₄	+1

There is, however, an exception to this rule for hydrogen. It is possible for hydrogen to form compounds with some metals that are even more electropositive than hydrogen. In these cases, hydrogen becomes an electron acceptor instead of an electron donor. Active metals lose or partially lose their valence electrons to hydrogen. Since hydrogen is acting as the more electronegative element in these compounds, the compounds are named hydrides (see examples in **Table 23.6**). In hydrides, the oxidation number of hydrogen is -1 .

TABLE 23.6: Examples of Oxidation Numbers for Hydrogen in Hydride Compounds

Substance	Oxidation Number for Hydrogen
LiH (lithium hydride)	-1
NaH (sodium hydride)	-1
MgH ₂ (magnesium hydride)	-1

The sixth rule is about the oxidation number of oxygen in compounds. Oxygen is a very electronegative element that draws two electrons completely or partially from a bonding element in almost all of its compounds. Therefore, the oxidation number for oxygen in compounds is almost always -2 (see examples in **Table 23.7**).

TABLE 23.7: Examples of Oxidation Numbers for Oxygen in Compounds

Substance	Oxidation Number for Oxygen
H ₂ O	-2
MgO	-2
H ₂ SO ₄	-2
Na ₂ Cr ₂ O ₇	-2
C ₆ H ₁₂ O ₆	-2

Like hydrogen, there is an exception to the rule for oxygen. In a group of compounds named “peroxides” (hydrogen peroxide H₂O₂, sodium peroxide Na₂O₂, etc.), each of the oxygen atoms shares a bond with the other oxygen atom. Therefore, the oxygen atoms only accept one electron from the other element, so oxygen has an oxidation number of -1 in peroxides (see examples in **Table 23.8**).

TABLE 23.8: Examples of Oxidation Numbers for Oxygen in Peroxides

Substance	Oxidation Number for Oxygen
H ₂ O ₂	-1
Na ₂ O ₂	-1

Some other elements exhibit only one possible gain, loss, or sharing of electrons when they form compounds. Aluminum, for example, always loses or partially loses three electrons when it forms compounds, so its oxidation

number in compounds is +3. Zinc always loses or partially loses two electrons when it combines, so its oxidation number in compounds is +2. The halogens (family VIIA) always gain one electron in binary compounds and would have an oxidation number of -1 in these compounds. Some of the halogen atoms form compounds where there are three elements, and one of them is oxygen (HClO_3 , for example). In these compounds, the halogen atom is almost never -1 .

There will be quite a few atoms whose oxidation number may be different in different compounds. For these, you will have to calculate their oxidation numbers. To allow you make such calculations, there is a general rule that the sum of the oxidation numbers of all the atoms in a compound must be zero, and the sum of all the oxidation numbers of the atoms in a polyatomic ion must equal the charge on the ion.

Example:

What is the oxidation number of sulfur in Na_2SO_4 ?

Solution:

We have three pieces of information that will allow us to calculate the oxidation number of sulfur. We know that the sum of the oxidation numbers of all the atoms will equal zero.

$$2(\text{Na}) + 1(\text{S}) + 4(\text{O}) = 0$$

We also know the oxidation number of sodium from rule 3 is $+1$ and the oxidation number of oxygen from rule 6 is -2 . We simply plug these values into the equation and solve for the oxidation number of sulfur.

$$2(1) + 1(x) + 4(-2) = 0 \text{ so } x = +6$$

Example:

What is the oxidation number of chromium in $\text{K}_2\text{Cr}_2\text{O}_7$?

Solution:

$$\begin{aligned} 2(\text{K}) + 2(\text{Cr}) + 7(\text{O}) &= 0 \\ 2(+1) + 2(x) + 7(-2) &= 0 \\ \text{so } x &= +6 \end{aligned}$$

Example:

What is the oxidation number of nitrogen in the nitrate ion, NO_3^- ?

Solution:

$$\begin{aligned} 1(\text{N}) + 3(\text{O}) &= -1 \\ 1(x) + 3(-2) &= -1 \\ \text{so } x &= +5 \end{aligned}$$

Example:

What is the oxidation number of phosphorus in the phosphate ion, PO_4^{3-} ?

Solution:

$$\begin{aligned} 1(\text{P}) + 4(\text{O}) &= -3 \\ 1(x) + 4(-2) &= -3 \\ \text{so } x &= +5 \end{aligned}$$

Example:

What is the oxidation number of iron in Fe_2O_3 ?

Solution:

$$\begin{aligned}2(\text{Fe}) + 3(\text{O}) &= 0 \\2(x) + 3(-2) &= 0 \\ \text{so } x &= +3\end{aligned}$$

Example:

What is the oxidation number of iron in Fe_3O_4 ?

Solution:

This example was chosen specifically to make a point.

$$\begin{aligned}3(\text{Fe}) + 4(\text{O}) &= 0 \\3(x) + 4(-2) &= 0 \\ \text{so } x &= \frac{8}{3}\end{aligned}$$

In this case, we get an oxidation number that is not a whole number. Since this number supposedly represents the number of electrons gained or lost from the elemental state, we should feel uncomfortable about an oxidation number of $\frac{8}{3}$. We know that an atom did not lose a fraction of an electron. The reason that the oxidation number appears to be fractional is because some of the iron atoms in Fe_3O_4 lost 3 electrons, and some lost 2. Another way to represent this molecule is as $\text{FeO}\cdot\text{Fe}_2\text{O}_3$. In this case, it is easy to see that the Fe attached to one O is in a +2 oxidation state, whereas the Fe in the Fe_2O_3 is in the +3 oxidation state.

Lesson Summary

- Oxidation is the loss of electrons or a gain in oxidation number.
- Reduction is the gain of electrons or a decrease in oxidation number.
- The oxidizing agent is the substance causing oxidation and is itself reduced.
- The reducing agent is the substance causing reduction and is itself oxidized.
- Oxidation and reduction always occur simultaneously.
- A reaction involving the gain and loss of electrons is called an oxidation-reduction or redox reaction.
- We use a bookkeeping system called oxidation numbers to keep track of the electrons gained and lost during a redox reaction.

Further Reading / Supplemental Links

This website offers a short animated video on electron transfer during oxidation-reduction.

- <http://www.youtube.com/watch?v=e6Xxz-VBE6s>

This web site offers more information on oxidation-reduction and other aspects of electrochemistry.

- <http://www.chemtutor.com/redox.htm>

Review Questions

1. Indicate the oxidation numbers for each of the following atoms.
 - a. Mn^{2+}
 - b. Al
 - c. Al in Al_2O_3
 - d. Br in NaBr
 - e. Fe in Fe_2O_3
 - f. arsenic in AsO_4^{3-}
 - g. chlorine in ClO_4^-
 - h. sulfur in H_2SO_3
2. In the following reaction, identify the element that is being oxidized and the element that is being reduced:
 $\text{MnO}_2 + 4 \text{HCl} \rightarrow \text{MnCl}_2 + \text{Cl}_2 + 2 \text{H}_2\text{O}$.

23.3 Balancing Redox Equations Using the Oxidation Number Method

Lesson Objectives

The student will:

- determine which substances in a redox equation are changing their oxidation state.
- balance redox equations using the oxidation number method.

Introduction

The method you have used previously to balance equations was by inspection, that is, it was a trial and error method. You would keep trying numbers, using intelligent guesses, until you get the simplest whole number ratio that balances. That method works very well and very quickly for simpler reactions, but with the more complex redox reactions, that method will not work. As an example, here is the unbalanced net ionic equation for the reaction of silver ions with copper atoms.

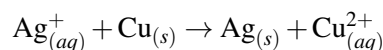

By the inspection method, this equation would be balanced as is. This is not the correct answer, however, for this reaction. The properly balanced equation for this reaction is actually:

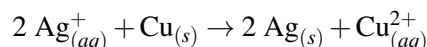

In non-redox reactions, all that is required is to balance the number of atoms or molecules of each species. In redox reactions, you must balance not only the number of atoms, ions, or molecules of each species, but you must also balance the gain and loss of electrons. Balancing redox reactions requires a process that may have up to ten steps.

Change of Oxidation State

A redox reaction occurs when an atom in the products has a different oxidation number than it had in the reactants. Since oxidation is always accompanied by reduction, there will usually be two species that change their oxidation state between the reactant side and the product side of the equation. In the following equation, oxidation numbers have been assigned to each atom in the equation.

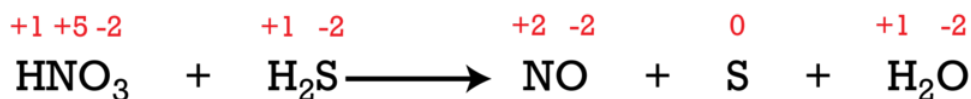

When we examine the oxidation number of each atom on the two sides of the equation, we discover that the oxidation state of nitrogen has changed from +5 to +2. Nitrogen has been reduced by gaining three electrons. The oxidation state of sulfur has also changed, going from +2 to 0. Sulfur, therefore, has been oxidized by losing two electrons. This is a redox reaction.

Balancing Redox Equations

The following example illustrates the steps involved in balancing redox equations.

Example:

Balance the following redox equation:

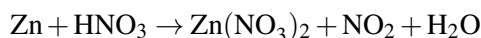

Solution:

Step 1: Assign oxidation numbers to all the atoms in the reaction.

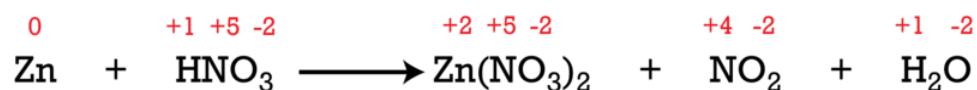

Step 2: Determine which atom is being oxidized and write a half-reaction for the oxidation process, showing the species containing the atom being oxidized and the product containing that atom.

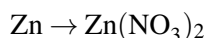

Step 3: Determine which atom is being reduced and write a half-reaction for the reduction process, showing the species containing the atom being reduced and the product containing that atom.

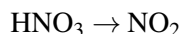

Step 4: If the atoms being oxidized and reduced are not already balanced in the half-reactions, balance them.

In this case, the atoms being oxidized and reduced are already balanced.

Step 5: Add the appropriate number of electrons to each half-reaction needed to bring about the reduction and oxidation.

Since the zinc with oxidation number of 0 is losing two electrons to become the zinc with oxidation number of +2,



Since the nitrogen with oxidation number +5 is gaining one electron to become the nitrogen with oxidation number +4,

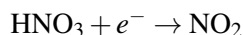

Step 6: Determine the lowest common multiple (LCM) of the number of electrons in each half-reaction and multiply each half-reaction by whatever multiplier is necessary to make the number of electrons in the half-reaction equal to the LCM.

In this case the LCM is 2, so the first half-reaction needs no multiplier, and the second half-reaction is multiplied by 2.

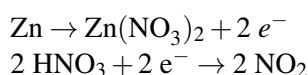

Step 7: Add the two half-reactions and cancel equal numbers of any species that appears on both sides.

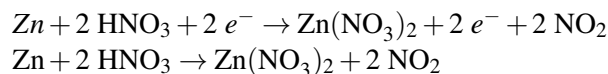

Step 8: Check the final equation to make sure it is balanced in terms of both atoms and charge.

Example:

Balance the following redox equation:

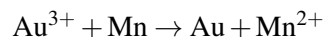

Solution:

Step 1: Assign oxidation numbers to all the atoms in the reaction.

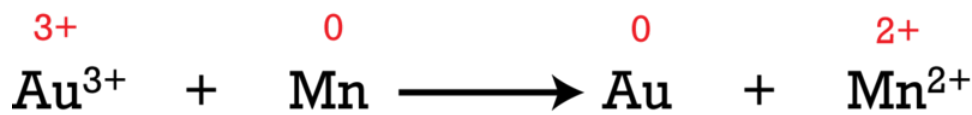

Step 2: Determine which atom is being oxidized and write a half-reaction for the oxidation process, showing the species containing the atom being oxidized and the product containing that atom.

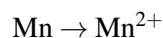

Step 3: Determine which atom is being reduced and write a half-reaction for the reduction process, showing the species containing the atom being reduced and the product containing that atom.

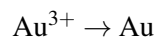

Step 4: If the atoms being oxidized and reduced are not already balanced in the half-reactions, balance them.

In this case, the atoms being oxidized and reduced are already balanced.

Step 5: Add the appropriate number of electrons to each half-reaction needed to bring about the reduction and oxidation.

Since manganese with oxidation number of 0 is losing two electrons to become manganese with oxidation number of +2,

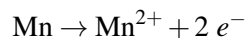

Since gold with oxidation number +3 is gaining three electron to become gold with oxidation number 0,

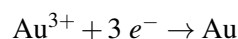

Step 6: Determine the lowest common multiple (LCM) of the number of electrons in each half-reaction and multiply each half-reaction by whatever multiplier is necessary to make the number of electrons in the half-reaction equal to the LCM.

In this case the LCM is 6, so the first half-reaction needs to be multiplied by 3 and the second half-reaction needs to be multiplied by 2.



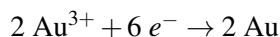

Step 7: Add the two half-reactions and cancel equal numbers of any species that appears on both sides.

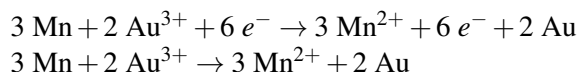

Step 8: Check the final equation to make sure it is balanced in terms of both atoms and charge.

Redox reactions often occur in solutions that are acidic or basic. When the reaction occurs in acidic or basic solution, there are a few more steps in the balancing process. In an acidic solution, hydrogen ions are available in the solution. In a basic solution, hydroxide ions are available in the solution. When a redox reaction occurs in acid solution, add hydrogen ions and water to the equation wherever they are needed to balance. When the redox reaction occurs in base solution, add hydroxide ions and water wherever needed to balance.

Example:

Balance the following redox equation. It is in an acid solution.

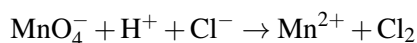

Step 1: Assign oxidation numbers.

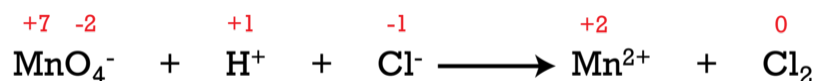

Step 2: Determine which atom is being oxidized and write a half-reaction for the oxidation process, showing the species containing the atom being oxidized and the product containing that atom.

The chlorine whose oxidation number is -1 is being oxidized to chlorine with an oxidation number of 0.

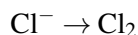

Step 3: Determine which atom is being reduced and write a half-reaction for the reduction process, showing the species containing the atom being reduced and the product containing that atom.

The manganese with +7 oxidation number is being reduced to manganese with oxidation number +2.

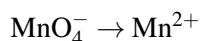

Step 4: If the atoms being oxidized and reduced are not already balanced in the half-reactions, balance them.

In this case, the manganese is balanced in the reduction half-reaction so nothing is needed, but the chlorine is not balanced in the oxidation half-reaction so a coefficient of 2 must be entered in the reactant side of that half-reaction.

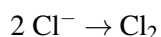

Step 5: Add the appropriate number of electrons to each half-reaction needed to bring about the reduction and oxidation.

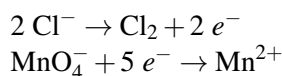

Step 6: Balance all other atoms in each half-reaction *except* hydrogen and oxygen.

In this case, all other atoms except hydrogen and oxygen are already balanced.

Step 7: In a redox reaction in acid solution, balance the hydrogen and oxygen in each half-reaction by adding water where needed to balance the oxygen and then add hydrogen ions where needed to balance the hydrogen.

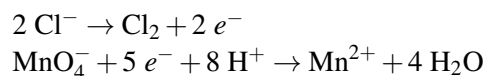

In this half-reaction, 4 water are needed to balance the oxygen and 8 H^+ are needed to balance the hydrogen. After this step, the charge in the half-reactions should be balanced. In this case, the oxidation half-reaction has a net -2 charge on each side of the equation and the reduction half-reaction has a net +2 charge on each side of the equation. Therefore, the charge is balanced.

Step 8: Determine the lowest common multiple (LCM) of the number of electrons in each half-reaction and multiply each half-reaction by whatever multiplier is necessary to make the number of electrons in the half-reaction equal to the LCM.

In this case the LCM is 10, so the first half-reaction needs to be multiplied by 5, and the second half-reaction needs to be multiplied by 2.

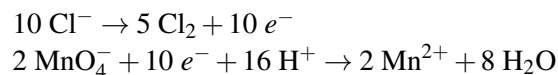

Step 9: Add the two half-reactions and cancel equal numbers of any species that appears on both sides.

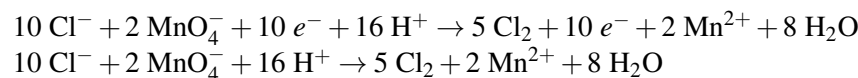

Step 10: Check the final equation to make sure it is balanced in terms of both atoms and charge.

Example:

Balance the following equation. It is in a basic solution.

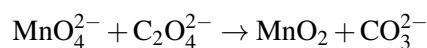

Step 1: Assign oxidation numbers.

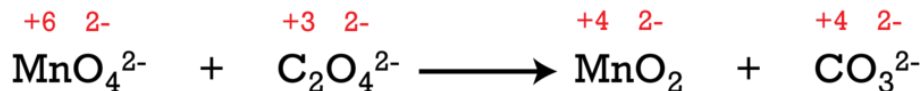

Step 2: Determine which atom is being oxidized and write a half-reaction for the oxidation process, showing the species containing the atom being oxidized and the product containing that atom.

The carbon with oxidation number +3 is losing one electron and becoming carbon with an oxidation number of +4.

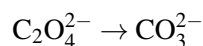

Step 3: Determine which atom is being reduced and write a half-reaction for the reduction process, showing the species containing the atom being reduced and the product containing that atom.

The manganese atoms with oxidation numbers of +6 and accepting two electrons and becoming manganese atoms with an oxidation number of +4.

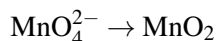

Step 4: If the atoms being oxidized and reduced are not already balanced in the half-reactions, balance them.

In this case, the oxidation half-equation requires a coefficient of 2 in front of the carbonate ion. In the reduction half-equation, the manganese is already balanced.

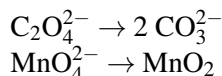

Step 5: Add the appropriate number of electrons to each half-reaction needed to bring about the reduction and oxidation.

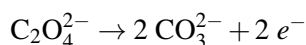

Each carbon is giving up one electron, and since there are two carbon atoms in the half-equation, two electrons are required.

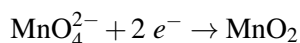

Step 6: Balance all other atoms in each half-reaction *except* hydrogen and oxygen.

With the exception of hydrogen and oxygen, all atoms in the equations are balanced.

Step 7: In a redox reaction in basic solution, balance the charge first by adding OH^- and then balance the oxygen by adding H_2O . The hydrogen should balance automatically.

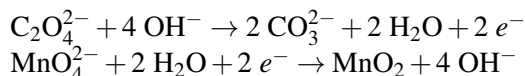

Step 8: Determine the lowest common multiple (LCM) of the number of electrons in each half-reaction and multiply each half-reaction by whatever multiplier is necessary to make the number of electrons in the half-reaction equal to the LCM.

In this case the LCM is 2, so neither half-equation needs to be multiplied.

Step 9: Add the two half-reactions and cancel equal numbers of any species that appears on both sides.

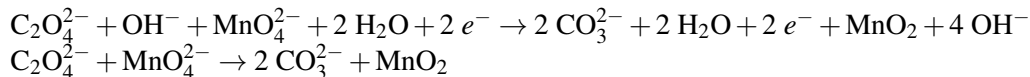

Step 10: Check the final equation to make sure it is balanced in terms of both atoms and charge.

This video shows the process in balancing a redox equation (**3g**): <http://www.youtube.com/watch?v=TBmwhTzc4Io> (8:19).

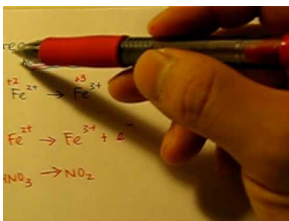

MEDIA

Click image to the left for more content.

Lesson Summary

- The following are the steps to balance a redox reaction.
 1. Assign oxidation numbers for all atoms in the reaction.
 2. Determine which atom is being oxidized and write a half-reaction for the oxidation process, showing the species containing the atom being oxidized and the product containing that atom.
 3. Determine which atom is being reduced and write a half-reaction for the reduction process, showing the species containing the atom being reduced and the product containing that atom.
 4. If the atoms being oxidized and reduced are not already balanced in the half-reactions, balance them.
 5. Add the appropriate number of electrons to each half-reaction needed to bring about the reduction and oxidation.
 6. Balance all other atoms in each half-reaction except H and O.
 7. Balance the H and O according to either (a) or (b) depending on whether the reaction is acidic or basic.
 - (a) If the reaction is acidic, add H_2O and H^+ . Balance O first by adding H_2O , then balance H by adding H^+ . Charge should now be balanced.
 - (b) If the reaction is basic, add OH^- and H_2O . Balance charge first by adding OH^- , then balance O by adding H_2O . The H should now be balanced.
 8. Determine the lowest common multiple (LCM) of the number of electrons in each half-reaction and multiply each half-reaction by whatever multiplier is necessary to make the number of electrons in the half-reaction equal to the LCM.
 9. Add the two half-reactions and cancel those species that are common to both sides.
 10. Check the equation to be sure that it is balanced in terms of both atoms and charge.

Further Reading / Supplemental Links

The following website provides more information in balancing redox reactions.

- http://preparatorychemistry.com/Bishop_Balancing_Redox.htm

Review Questions

1. Balance the following equation using the oxidation number method.



2. Balance the following equation using the oxidation number method.

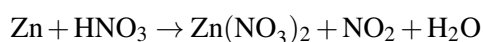

3. In terms of electron gain and loss, explain why chlorine undergoes both oxidation and reduction in the following unbalanced reaction.



4. Balance the equation in the previous problem.

23.4 Electrolysis

Lesson Objectives

The student will:

- identify the anode and the cathode given a diagram of an electrolysis apparatus that includes the compound being electrolyzed.
- write oxidation and reduction half-reactions given a diagram of an electrolysis apparatus that includes the compound being electrolyzed.

Vocabulary

- anode
- cathode
- electric current
- electrolysis
- electroplating
- ionic conduction
- metallic conduction

Introduction

Electrolysis involves using an electric current to force an otherwise non-spontaneous chemical reaction to occur.

Electric Current

Any flow of electric charge is an **electric current**. Electrons are far easier to remove from atoms than protons, so most of the electric current you experience in daily life is electron flow. Electrons move easily through a piece of metal because of the freedom of movement of valence electrons in the metallic bond. The movement of electrons through a piece of metal is called **metallic conduction**. An electric current also exists when positive or negative ions move along a path. The movement of ions through a solution is called **ionic conduction**.

Electric current of all types flow because there is a difference in electric potential energy at two positions. A common device for providing this difference in electric potential energy is a battery. A battery has two terminals, and chemical reactions inside the battery cause one terminal to have higher electric potential energy than the other terminal. The higher potential energy terminal is called the negative terminal, and the other terminal is called the positive terminal. If a low resistance path is provided, electrons will flow along the path from high to low potential energy. A metal wire provides such a low resistance path for electrons. The potential energy lost by the electrons as they move

from high electric potential energy to low electric potential energy is converted into heat and light by the light bulb filament, as illustrated below.

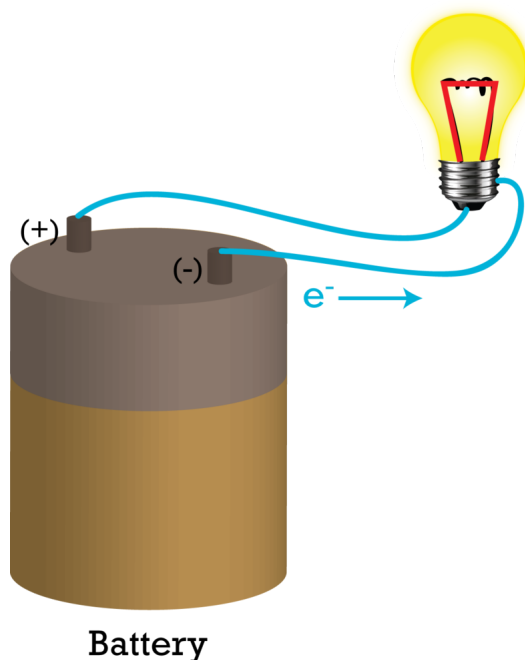

Current Through an Electrolyte

If we connect pieces of metal to the terminals of a battery with wires and suspend the pieces of metal (called electrodes) in an ionic solution as shown below, the high potential energy electrons will flow onto the negative electrode. Simultaneously, some electrons will flow off the other electrode, leaving it positive.

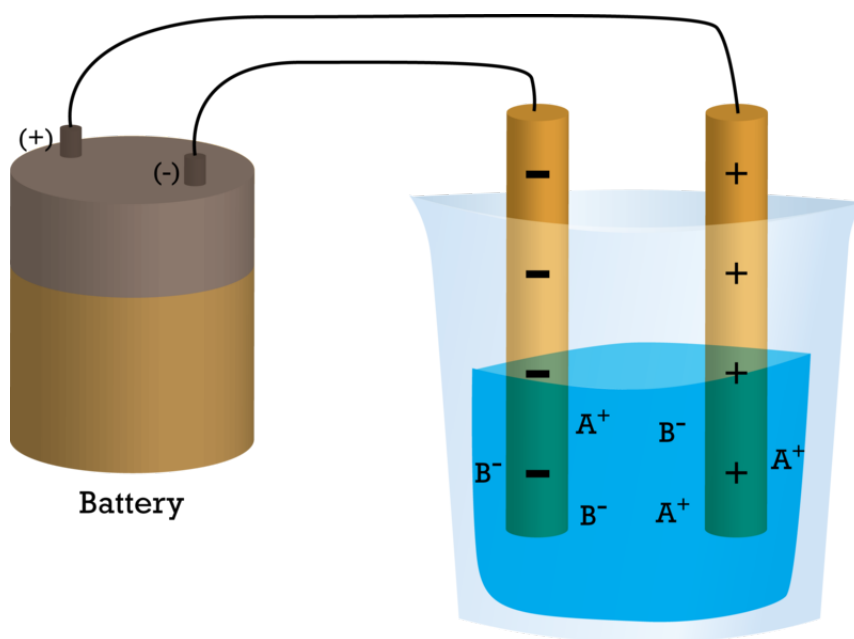

The cations (A^+) in the solution are attracted to the negative electrode and will migrate through the solution to contact the negative electrode. When a +1 cation contacts the negative electrode, it will pick up an electron from

the electrode and become a neutral atom. In this way, electrons leave the negative electrode. You should recognize that the cations that have picked up an electron are reduced.

At the same time the positive ions are migrating toward the negative electrode, the anions (B^-) are migrating toward the positive electrode. When a negative ion touches the positive electrode, it gives up its extra electron to the electrode and becomes a neutral atom. The anions that donate electrons to the positive electrode are oxidized. In this way, electrons are added to the positive electrode. Even though the electrons that leave the negative terminal of the battery and the ones that arrive at the positive terminal are not the same, the circuit is nevertheless complete. As illustrated below, current flows through the circuit just as if a wire had been placed between the two electrodes. The processes that occur at the two electrodes are simultaneous.

You should also realize that the ions in the solution are being consumed by this process, and the current will only flow as long as there are ions to accept and donate electrons. Once the solution runs out of ions, current flow stops. When a current flows through an electrolyte in this manner, the electrolytic solution is called the internal part of the circuit, and the wires and battery are called the external part of the circuit.

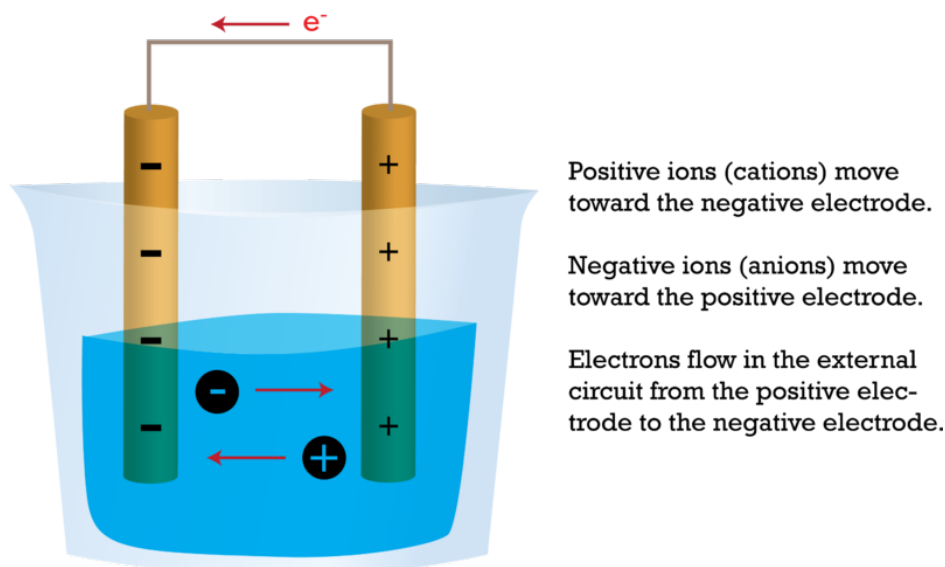

Electrolysis of Liquid NaCl

Solid sodium chloride consists of alternating sodium ions and chloride ions in a tightly packed, three-dimensional, crystal lattice (as seen in the image below). Ionic solids do not conduct electric current because the ions cannot migrate through the solid material. If sodium chloride is heated to a high enough temperature, however, it melts to a liquid. In the liquid form, ions can migrate. Therefore, ionic substances in liquid form will conduct electricity in approximately the same way as ions in solution.

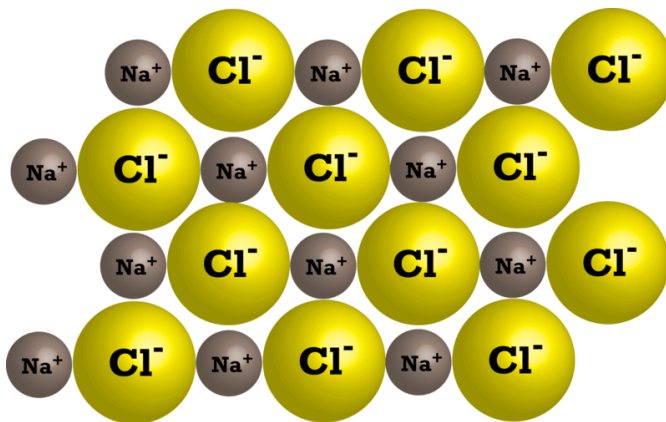

If electrodes connected to battery terminals are placed in liquid sodium chloride, the sodium ions will migrate toward the negative electrode and be reduced while the chloride ions migrate toward the positive electrode and are oxidized. The processes that occur at the electrodes can be represented by what are called half-equations.

At the positive electrode: $\text{Na}^+ + e^- \rightarrow \text{Na}$ (reduction)

At the negative electrode: $2 \text{Cl}^- \rightarrow \text{Cl}_2 + 2 e^-$ (oxidation)

Half-equations are very helpful in discussing and analyzing processes, but half-reactions cannot occur as they appear. Both oxidation and reduction must occur at the same time, so the electrons are donated and absorbed nearly simultaneously.

The two half-reactions may be added together to represent a complete reaction. In order to add the half-reactions, the number of electrons donated and the number of electrons accepted must be equal. In the case of the oxidation of the chloride ion and the reduction of the sodium ion, the sodium half-reaction must be doubled so that each half-reaction involves two electrons.

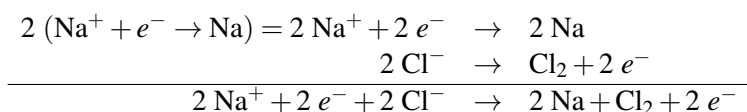

The two electrons on each side of the equation can be canceled, and we are left with the net reaction for the electrolysis of sodium chloride.

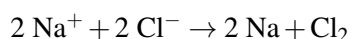

Many chemical reactions occur spontaneously because the products have less potential energy than the reactants. In electrolysis reactions, however, the products have more potential energy than the reactants. Electrolysis reactions will not run unless energy is put into the system from outside. In the case of electrolysis reactions, the energy is provided by the battery.

Electrolysis of Water

If we place electrodes connected to the terminals of a battery into pure water, no current is conducted and no electrolysis occurs. This is because ions must be present in order for a current to be conducted. Even though water is very slightly ionized to H^+ and OH^- ions, the concentrations of these ions is too small to produce electrolysis. When a small amount of ion-supplying substance, such as H_2SO_4 or Na_2SO_4 , is added to the water in the electrolysis set-up, hydrogen gas is rapidly produced at the negative electrode and oxygen gas is produced at the positive electrode. We will now call the negative electrode the **cathode** and the positive terminal the **anode**. The cathode is the electrode

where reduction occurs, and the anode is the electrode where oxidation occurs. Cations were so named because they are attracted to the cathode, and anions were so named because they are attracted to the anode.

In the electrolysis of water, oxidation and reduction half-reactions are:

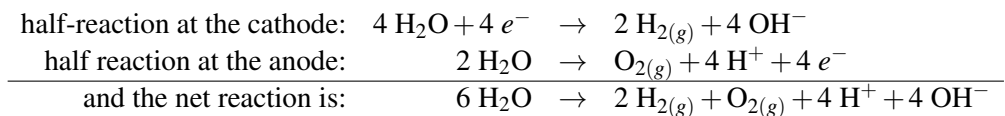

(This is the net reaction if the two half-reactions occur in separate chambers. If the two half-reactions occur in the same chamber, the proton and hydroxide ions react to form water.)

Electroplating

With appropriate treatment of the electrode material and appropriate adjustment of the current level from the battery, it is possible to get the metal being reduced to adhere strongly to the electrode during the electrolysis process. The use of electrolysis to coat one material with a layer of metal is called **electroplating**. Usually, electroplating is used to cover a cheap metal with a layer of more expensive and more attractive metal. Sometimes, electroplating is used to get a surface metal that is a better conductor of electricity. When you wish to have the surface properties of gold (attractive, corrosion resistant, or good conductor), but you don't want to have the great cost of making the entire object out of solid gold, the answer may be to use cheap metal to make the object and then electroplate a thin layer of gold on the surface.

To silver plate an object like a spoon, the spoon is placed in the position of the cathode in an electrolysis set up with a solution of silver nitrate. When the current is turned on, the silver ions will migrate through the solution, touch the cathode (spoon), and adhere to it. With enough time and care, a layer of silver can be plated over the entire spoon. The anode for this operation would often be a large piece of silver from which silver ions would be oxidized, and these ions would enter the solution. This is a way of ensuring a steady supply of silver ions for the plating process.

Half-reaction at the cathode: $\text{Ag}^+ + e^- \rightarrow \text{Ag}$

Half-reaction at the anode: $\text{Ag} \rightarrow \text{Ag}^+ + e^-$

Some percentage of the gold and silver jewelry sold is electroplated. The connection points in electric switches are often gold plated to improve electrical conductivity, and most of the chromium pieces on automobiles are chromium plated.

Lesson Summary

- An electric current consists of a flow of charged particles.
- When direct current is passed through a solution of an electrolyte, cations are attracted to the negative electrode where they gain electrons, and anions are attracted to the positive electrode where they lose electrons.
- The electrode where oxidation occurs is called the anode, and the electrode where reduction occurs is called the cathode.
- In electroplating, the object to be plated is made the cathode in an electrolysis.

Further Reading / Supplemental Links

This website provides an interactive animation of electrolysis.

- <http://www.chem.iastate.edu/group/Greenbowe/sections/projectfolder/flashfiles/electroChem/electrolysis10.html>

Review Questions

1. Write the equations for the reactions that occur at the anode and at the cathode in the electrolysis of molten KBr.

23.5 Galvanic Cells

Lesson Objectives

The student will:

- describe the conditions necessary for a cell to be a standard cell.
- balance the redox equation, calculate the standard cell potential, and determine the direction of electron flow in the external circuit given a table of standard reduction potentials and a diagram or description of a Galvanic cell.

Vocabulary

- electrochemical cell
- salt bridge
- voltage

Introduction

Electrochemistry can be defined as the study of the interchange of electrical and chemical energy. Electrochemical reactions generate an electric current from a spontaneous chemical reaction.

Spontaneous Redox Reactions

Electrolysis requires a direct electric current in order to drive a non-spontaneous redox reaction, but spontaneous redox reactions are also very common. These reactions occur because the products contain less potential energy in their bonds than the reactants do. The energy produced from excess potential energy not only allows the reaction to occur, but it often gives off energy to the surroundings. Some of these reactions can be physically arranged so that the energy given off is in the form of an electric current. These are the type of reactions that occur inside batteries. When a reaction is arranged to produce an electric current as it runs, the arrangement is called an **electrochemical cell** or a Galvanic Cell.

If a strip of copper is placed in a solution of silver nitrate, the following reaction takes place:

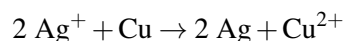

In this reaction (illustrated below), copper atoms are donating electrons to silver ions so that the silver ions are reduced to silver atoms and the copper atoms are oxidized to copper(II) ions.

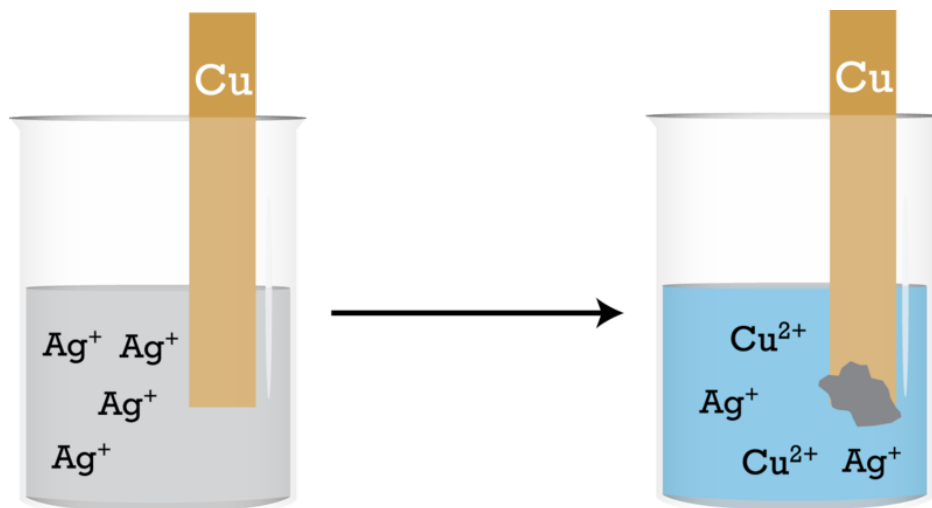

As the reaction occurs, an observer would see the solution slowly turn blue (Cu^{2+} ions are blue in solution), and a mass of solid silver atoms would build up on the copper strip.

Electrochemical Cells

The reaction $2 \text{Ag}^+ + \text{Cu} \rightarrow 2 \text{Ag} + \text{Cu}^{2+}$ is one that could be physically arranged to produce an external electric current. To do this, the two half-reactions must occur in separate compartments, and the separate compartments must remain in contact through an ionic solution and an external wire.

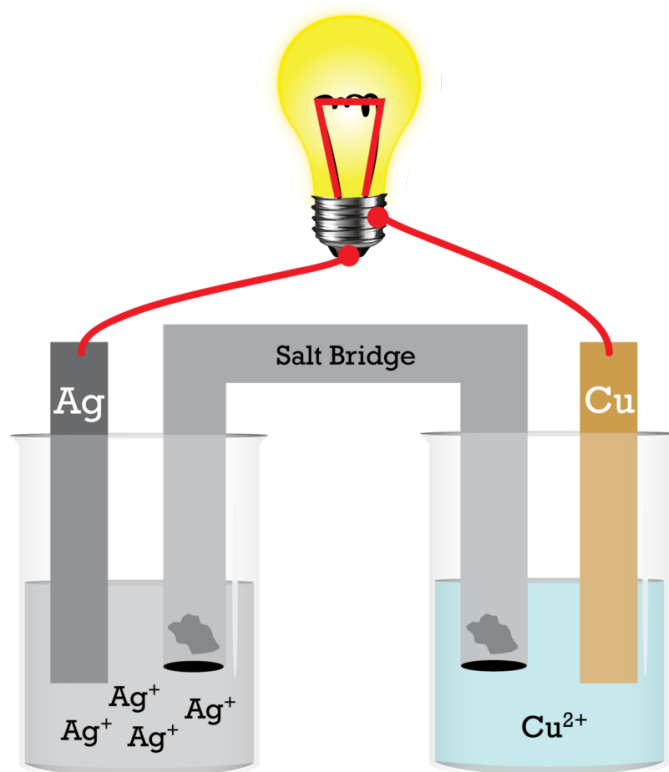

In the electrochemical cell illustrated above, the copper metal must be separated from the silver ions to avoid a direct reaction. Each electrode in its solution could be represented by the following half-reactions:

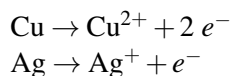

The external wire will allow electrons to flow between the metal strips. In each half-cell, atoms may be oxidized to ions, leaving excess electrons on the electrode. It can be determined experimentally that electrons will flow in the wire from the copper electrode to the silver electrode. The reason for the direction of electron flow can be explained in several ways. We could say that silver ions have a greater electron affinity than copper ions, so the silver atoms pull the electrons through the wire from copper. On the other hand, we could also say that copper atoms have a greater tendency to give up electrons than silver, so the copper electrode becomes more negative and will push the electrons through the wire toward the silver electrode. Whichever way we look at it, the electrons flow from copper to silver in the external wire. The silver electrode, therefore, will acquire an excess of electrons that causes the silver half-reaction to run in the reverse direction.

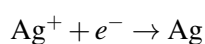

As the electrons on the silver electrode are used up in the reduction of silver ions, more copper atoms are oxidized, and more electrons sent through the wire. The net reaction for the entire cell is:

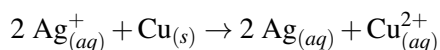

As the cell runs, electrons are transferred from the copper half-cell to the silver half-cell. Unchecked, this reaction would result in the silver half-cell becoming negatively charged and the copper half-cell becoming positively charged. Once the half-cells became charged in that manner, the reaction could only continue to run if it produced sufficient energy to take electrons away from a positive charge and push them onto an already negatively charged half-cell. Chemical reactions, however, do not produce enough energy to push electrons against a charge gradient.

The salt bridge is present to allow negative ions to flow from the silver half-cell to the copper half-cell, and positive ions to flow from the copper half-cell to the silver half-cell. This migration of ions balances the charge movement of the electrons. The **salt bridge** is the upside-down U-shaped tube connecting the two beakers in the image above. This tube is filled with an ionic solution, and the ends are fitted with porous plugs. An ionic solution is chosen such that neither of its ions will react chemically with any of the other ions in the system. The porous plugs are there to avoid general mixing but to allow ion migration. If the salt bridge were not present or were removed, the reaction would immediately stop. As long as the two beakers remain neutral and there are sufficient reactants (Ag^{+} and Cu) to continue the reaction, the reaction will continue to run.

We can now see that the silver electrode is the cathode because cations migrate toward it and because reduction occurs there. The copper electrode is the anode because anions migrate toward it and because oxidation occurs there. As the cell runs and produces electric current, the mass of the silver electrode increases because when a silver ion is reduced to a silver atom, it attaches to the silver electrode. The copper electrode will lose mass because as a copper atom is oxidized to a copper ion, it dissolves in the solution. Eventually, the silver electrode will show a mass of attached solid silver, and the copper electrode will develop holes and edges as evidence of the reaction wearing away the strip.

The electrons that pass through the external circuit can do useful work, such as lighting lights, running cell phones, and so forth. Several cells can be operated together to produce greater current. When we have a series of cells operating together as one, we call the arrangement a battery. If the light bulb is removed from the circuit with the electrochemical cell and replaced with a voltmeter (see illustration below), the voltmeter will measure the **voltage** (electrical potential energy per unit charge) of the combination of half-cells.

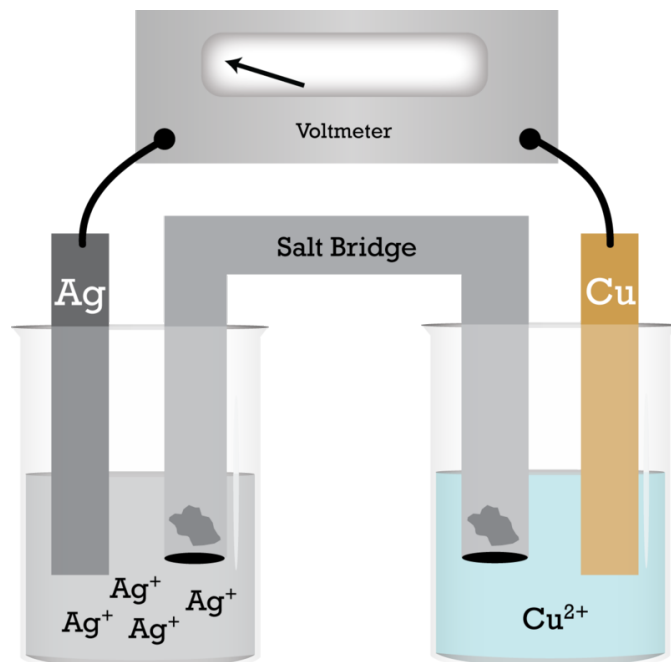

The size of the voltage produced by a cell depends on the temperature, the metals used for electrodes, and the concentrations of the ions in the solutions. If you increase the concentration of the reactant ion (not the product ion), the reaction rate will increase and so will the voltage.

It may seem complicated to construct an electrochemical cell because of all its complexities. Electrochemical cells, however, are actually easy to make and sometimes even occur accidentally. If you take two coins of different metal composition, one copper and one silver for example, and push them part way through the peel of a whole lemon (as illustrated below), upon connecting the two coins with a wire, a small electric current will flow.

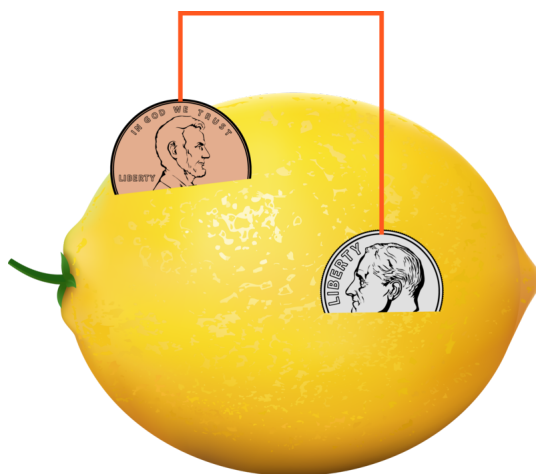

Electrochemical cells occasionally occur accidentally when two water pipes of different material are connected. The reactions at the joint cause a great deal of corrosion. Plumbing professionals take great care to make sure such reactions do not occur at pipe joints.

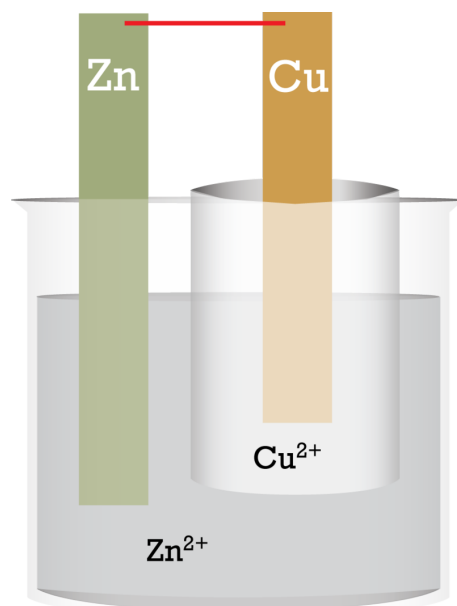

Another common way to construct an electrochemical cell is with the use of a porous cup, as shown in the figure above. A porous cup is made of a material that is permeable to ions and allows the ions to migrate through the walls. The cup is not, however, porous enough to allow liquid to flow through. Unfinished clay is one such substance. The porous cup is soaked in ionic solution to ensure that the pores are filled with ionic solution. One electrode and its solution are placed in the porous cup, and the other electrode and its corresponding ionic solution is placed in a beaker. The porous cup with its contents is then set inside the beaker, and a wire is connected between the electrodes. The walls of the porous cup act as the salt bridge in this cell.

This animation shows the function of a galvanic cell: <http://www.youtube.com/watch?v=A0VUsoeT9aM> (1:33).

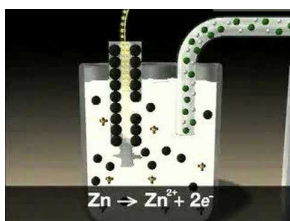

MEDIA

Click image to the left for more content.

The Standard Hydrogen Half-Cell

When designing cells for specific purposes, it would be very convenient if chemists were able to predict which half-reaction would gain electrons and which would lose. It would also be useful to predict the voltages that will be produced by various combinations of half-cells. Recall, however, that both the temperature and the concentrations of the ion solutions can change the reaction rate and the voltage of a cell. Therefore, the conditions for comparing half-reactions must be standardized. The conditions chosen to be the standard for half-cells are 25°C, 1.0 M for all solutions, and 1.0 atmosphere pressure.

It would be convenient if a chemist could make 100 standard half-cells, attach them to a voltmeter, and measure the voltage of each standard half-cell. Unfortunately, as you know, half-cells will not run alone. There must be two half-cells connected together; one where oxidation occurs and one where reduction occurs. When you connect two half-cells together, you can indeed measure the voltage produced, but you do not know how much of the voltage is due to each of the two standard half-cells. Chemists solved the problem by assigning the standard hydrogen half-cell

a potential of zero. When another standard half-cell was combined with the hydrogen half-cell, the cell voltage could be measured, and the potential of the cell assigned to the other half-cell.

For example, the standard silver half-cell, $\text{Ag}^+ + e^- \rightarrow \text{Ag}$, could be combined with the standard hydrogen half-cell, $2 \text{H}^+ + 2e^- \rightarrow \text{H}_2$, and the resultant voltage of the cell could then be measured. In this cell, the silver ions are reduced and the hydrogen atoms are oxidized. Since both half cells were written in terms of reduction, in order to write the equation for the cell, the hydrogen half-reaction must be reversed.

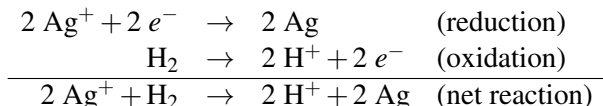

When this cell runs, it produces a voltage of 0.80 volts. This voltage is assigned to the silver half-cell as its voltage when the silver ions are reduced. The assigned voltages of 0.80 V for the silver half-cell and 0.00 V for the hydrogen half-cell do not have any meaning in terms of voltages on an absolute scale, but they are perfectly accurate as an indication of the difference in the abilities of the two half-cells to take electrons. The silver half-cell has a greater pull on electrons than the hydrogen half-cell, and it is stronger by 0.80 volts.

It was found that some of the standard half-cells are not strong enough to take electrons from the hydrogen half-cell. In fact, the hydrogen half-cell is the one that takes the electrons and forces the other half-reaction to oxidize. Since the hydrogen half-cell was assigned a strength of zero and these half-cells are weaker than hydrogen, their assigned voltages are negative numbers.

When many half-cells have been combined with the hydrogen half-cell and the voltages measured, we have a list of half-cells in order of their strength at taking electrons, and we have a numerical value for the difference in their strength compared to the hydrogen half-cell. **Table 23.9** is an expanded list of half-reactions and their assigned voltages based on comparison to the hydrogen half-cell.

TABLE 23.9: Standard Reduction Potentials

Half-Reactions	E° (volts)
$\text{F}_{2(g)} + 2 e^- \rightarrow 2 \text{F}^-$	+2.87
$\text{MnO}_4^- + 8 \text{H}^+ + 5 e^- \rightarrow \text{Mn}^{2+} + 4 \text{H}_2\text{O}$	+1.52
$\text{Au}^{3+} + 3 e^- \rightarrow \text{Au}_{(s)}$	+1.50
$\text{Cl}_{2(g)} + 2 e^- \rightarrow 2 \text{Cl}^-$	+1.36
$\text{Cr}_2\text{O}_7^{2-} + 14 \text{H}^+ + 6 e^- \rightarrow 2 \text{Cr}^{3+} + 7 \text{H}_2\text{O}$	+1.33
$\text{MnO}_{2(s)} + 4 \text{H}^+ + 2 e^- \rightarrow \text{Mn}^{2+} + 2 \text{H}_2\text{O}$	+1.28
$\frac{1}{2} \text{O}_{2(g)} + 2 \text{H}^+ + 2 e^- \rightarrow \text{H}_2\text{O}$	+1.23
$\text{Br}_{2(l)} + 2 e^- \rightarrow 2 \text{Br}^-$	+1.06
$\text{NO}_3^- + 4 \text{H}^+ + 3 e^- \rightarrow \text{NO}_{(g)} + 2 \text{H}_2\text{O}$	+0.96
$\text{Ag}^+ + e^- \rightarrow \text{Ag}$	+0.80
$\text{Hg}^{2+} + 2 e^- \rightarrow \text{Hg}_{(l)}$	+0.78
$\text{NO}_3^- + 2 \text{H}^+ + e^- \rightarrow \text{NO}_{2(g)} + \text{H}_2\text{O}$	+0.78
$\text{Fe}^{3+} + e^- \rightarrow \text{Fe}^{2+}$	+0.77
$\text{I}_{2(s)} + 2 e^- \rightarrow 2 \text{I}^-$	+0.53
$\text{Cu}^{2+} + 2 e^- \rightarrow \text{Cu}_{(s)}$	+0.34
$\text{SO}_4^{2-} + 4 \text{H}^+ + 2 e^- \rightarrow \text{SO}_{2(g)} + 2 \text{H}_2\text{O}$	+0.17
$\text{Sn}^{4+} + 2 e^- \rightarrow \text{Sn}^{2+}$	+0.15
$2 \text{H}^+ + 2 e^- \rightarrow \text{H}_{2(g)}$	0.00

TABLE 23.9: (continued)

Half-Reactions	E° (volts)
$\text{Pb}^{2+} + 2 e^- \rightarrow \text{Pb}_{(s)}$	-0.13
$\text{Sn}^{2+} + 2 e^- \rightarrow \text{Sn}_{(s)}$	-0.14
$\text{Ni}^{2+} + 2 e^- \rightarrow \text{Ni}_{(s)}$	-0.25
$\text{Co}^{2+} + 2 e^- \rightarrow \text{Co}_{(s)}$	-0.28
$\text{Fe}^{2+} + 2 e^- \rightarrow \text{Fe}_{(s)}$	-0.44
$\text{Cr}^{3+} + 3 e^- \rightarrow \text{Cr}_{(s)}$	-0.74
$\text{Zn}^{2+} + 2 e^- \rightarrow \text{Zn}_{(s)}$	-0.76
$2 \text{H}_2\text{O} + 2 e^- \rightarrow 2 \text{OH}^- + \text{H}_{2(g)}$	-0.83
$\text{Mn}^{2+} + 2 e^- \rightarrow \text{Mn}_{(s)}$	-1.18
$\text{Al}^{3+} + 3 e^- \rightarrow \text{Al}_{(s)}$	-1.66
$\text{Mg}^{2+} + 2 e^- \rightarrow \text{Mg}_{(s)}$	-2.37
$\text{Na}^+ + e^- \rightarrow \text{Na}_{(s)}$	-2.71
$\text{Ca}^{2+} + 2 e^- \rightarrow \text{Ca}_{(s)}$	-2.87
$\text{Sr}^{2+} + 2 e^- \rightarrow \text{Sr}_{(s)}$	-2.89
$\text{Ba}^{2+} + 2 e^- \rightarrow \text{Ba}_{(s)}$	-2.90
$\text{K}^+ + e^- \rightarrow \text{K}_{(s)}$	-2.92
$\text{Li}^+ + e^- \rightarrow \text{Li}_{(s)}$	-3.00

Example:

In a cell formed by the $\text{Cu}^{2+} + 2 e^- \rightarrow \text{Cu}$ and the $\text{Zn}^{2+} + 2 e^- \rightarrow \text{Zn}$ standard half-cells, determine which half-cell will undergo oxidation, which half-cell will undergo reduction, the voltage for the cell, and the balanced equation for the cell.

Solution:

Simply by looking at the placement of the half-reactions in the standard reduction potential chart, we can determine that the copper half-cell is closer to the top of the chart than the zinc half-cell, so we know that copper is better at attracting electrons and that half-reaction will run in the reduction direction. The zinc half-cell will be forced to give up electrons and be oxidized, so that half-reaction will also need to be reversed.

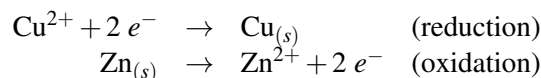

When a half-reaction is reversed in direction, the sign of the E° value must be changed. Therefore, the two half-reactions, along with their E° values, become:

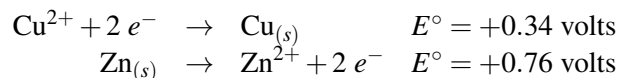

When the two half-reactions are added, we get both the balanced equation and the standard cell voltage.

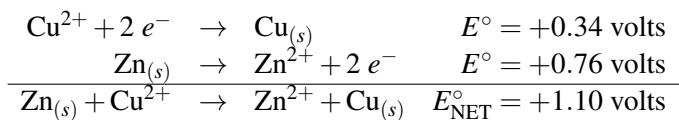
**Example:**

For the standard cell involving the dichromate half cell ($\text{Cr}_2\text{O}_7^{2-} + 14 \text{H}^+ + 6 e^- \rightarrow 2 \text{Cr}^{3+} + 7 \text{H}_2\text{O}$) whose E° is +1.33 volts, and the silver half-cell ($\text{Ag}^+ + e^- \rightarrow \text{Ag}_{(s)}$) whose E° is +0.80 volts, determine what will be oxidized and reduced, name the oxidizing and reducing agents, find the E_{NET}° for the cell, and balance the net equation.

Solution:

When we find the two half-reactions in the standard potential chart, the dichromate half-reaction is closer to the top of the chart, which means that it will run forward (reduction). The silver half-reaction, then, will be forced to reverse its direction (oxidation). We can write the two half-reactions in the direction they will run with the adjusted E° sign for the silver half-cell.

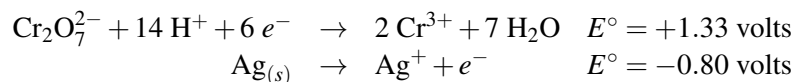

When we check the number of electrons on the two sides of the equation, we recognize that we must multiply the silver half-reaction by 6 in order for the electrons to cancel out. This brings up a question – when we multiply the half-reaction by 6, do we multiply the E° by 6? In the case of standard half-cells, in order for the half-cell to be standard, it *must* be at 25°C and the concentration of the ions *must* be 1.00 M. Hence, when you multiply a half-reaction in order to balance an equation, you may be doubling an amount of solution, but the molarity must remain exactly 1.00 M. Therefore, when you multiply a standard half-cell for balancing purposes, the E° remains exactly the same. The only instance where the E° of a standard half-cell changes is when the sign is changed to reverse the direction of the reaction. The half-reactions and net reaction for this problem become:

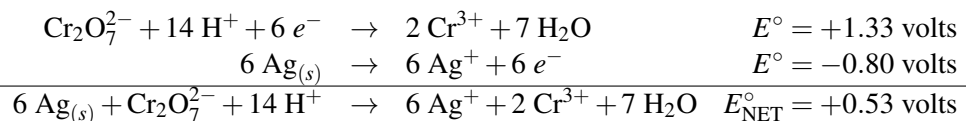

The chromium in $\text{Cr}_2\text{O}_7^{2-}$ is being reduced and is therefore the oxidizing agent. It is acceptable to just say the dichromate ion is the oxidizing agent rather than specifying the chromium in the dichromate ion.

The silver metal is being oxidized and is as a result the reducing agent.

This may be a convenient place to mention that standard cells last for only some small fraction of second when you turn them on. When cells begin to run, the ions on the reactant side of the equation are being used up, and the ions on the product side of the equation are being produced. When a standard cell begins to run, the molarities of the ions immediately change and are no longer exactly 1.00 M. Consequently, the cell is no longer a standard cell.

Electrochemical Reactions and Metallic Corrosion

The corrosion of metals is usually an electrochemical reaction. The reaction is usually between a metal and the oxygen and water in the surroundings. Iron is a material that readily rusts (corrodes) in contact with oxygen and moisture. Since iron is an extremely common metal used for many purposes, such as building construction, doors, fencing materials, ships hulls, bolts, screws, and nails, considerable effort is spent trying to keep iron from rusting. There are several common ways of protecting iron from corrosion.

The most common way of protecting iron objects from corrosion is to paint them so that the oxygen and moisture cannot touch the metal. This system would include storing the iron objects in thick grease to keep possible reactants away. In certain cases, iron can be alloyed with other metals to make the product more resistant to corrosion. Stainless steel is an alloy of iron and small amounts of chromium. The addition of the small amount of chromium makes the steel less susceptible to corrosion. The addition of small amounts of other substances when alloying with iron also yields other positive properties.

Metallic iron may also be coated with a protective layer of a more reactive metal. Iron objects are often electroplated with chromium or zinc to provide the protective layer. Sometimes iron objects are dipped in molten zinc to produce a layer of more reactive metal. Covering a metal with a layer of zinc is called galvanizing and is a fairly common practice with fence wire, nails, buckets, and tubs. To protect ship hulls from corrosion, it is common to place a large

mass of magnesium in electrical contact with the iron hull. The magnesium will corrode more easily than iron, so the reactants that contact the hull will react with the magnesium first, leaving the hull intact. This system is called cathodic protection.

Lesson Summary

- The redox reaction in an electrochemical cell is a spontaneous reaction.
- Ion flow between the chambers of an electrochemical cell keeps the chambers neutral.
- Standard potentials for half-cells are determined by measuring the potential of an electrochemical cell in which the tested cell is paired with the standard hydrogen half-cell.
- All standard potentials are measured at standard cell conditions of 25°C and 1.00 M solutions of all ions.
- The voltage of a standard electrochemical cell is obtained by finding the difference between the reduction potentials of the two half-cells.

Further Reading / Supplemental Links

The *learner.org* website allows users to view streaming videos of the Annenberg series of chemistry videos. You are required to register before you can watch the videos but there is no charge. The website has one video that relates to this lesson called “The Busy Electron” that explains the principles of electrochemical cell design through batteries, sensors, and a solar-powered car.

- <http://learner.org/resources/series61.html>

The following provides text and animations about electrochemical cells and batteries.

- <http://www.splung.com/content/sid/3/page/batteries>

Review Questions

1. In a standard cell composed of the zinc and copper half-cells, will the current in the external circuit flow from Zn to Cu or from Cu to Zn?
2. For a standard cell with the following balanced equation: $\text{Sn}_{(s)} + 2 \text{Ag}^+ \rightarrow \text{Sn}^{2+} + 2 \text{Ag}_{(s)}$,
 - a. what is being oxidized?
 - b. what is the reducing agent?
 - c. what is the E°_{NET} ?
 - d. after the reaction has reached equilibrium, what will be its voltage?
3. Balance the following equation using the half-reactions from the standard reduction potential chart: $\text{Cr}_2\text{O}_7^{2-} + \text{Fe}^{2+} + \text{H}^+ \rightarrow \text{Cr}^{3+} + \text{Fe}^{3+} + \text{H}_2\text{O}$.

All images, unless otherwise stated, are created by the CK-12 Foundation and are under the Creative Commons license CC-BY-NC-SA.

CHAPTER 24**Nuclear Chemistry****Chapter Outline**

- 24.1 DISCOVERY OF RADIOACTIVITY**
 - 24.2 NUCLEAR NOTATION**
 - 24.3 NUCLEAR FORCE**
 - 24.4 NUCLEAR DISINTEGRATION**
 - 24.5 NUCLEAR EQUATIONS**
 - 24.6 RADIATION AROUND US**
 - 24.7 APPLICATIONS OF NUCLEAR ENERGY**
 - 24.8 REFERENCES**
-

24.1 Discovery of Radioactivity

Lesson Objectives

The student will:

- describe the roles played by Henri Becquerel and Marie Curie in the discovery of radioactivity.
- list the most common emissions from naturally radioactive nuclei.

Vocabulary

- alpha particle
- beta particle
- gamma rays

Introduction

No one could have known in the 1800s that the discovery of the science and art form of photography would eventually lead to the splitting of the atom. The basis of photography is the fact that visible light causes certain chemical reactions. If the chemicals are spread thinly on a surface but protected from light by a covering, no reaction occurs. When the covering is removed, however, light acting on the chemicals causes them to darken. At the time of its discovery, photography was a strange and wonderful thing. Even stranger was the discovery by Wilhelm Conrad Röntgen that radiation other than visible light could expose photographic film. He found that film wrapped in dark paper would react when X-rays went through the paper and struck the film.

Becquerel and Radioactivity

When Henri Becquerel heard about Roentgen's discovery, he wondered if his fluorescent minerals would give the same X-rays. Becquerel placed some of his rock crystals on top of a well-covered photographic plate and sat them in the sunlight. The sunlight made the crystals glow with a bright fluorescent light, but when Becquerel developed the film, he was disappointed. He found that only one of his minerals, a uranium salt, had fogged the photographic plate. He decided to try again, leaving them out in the sun for a longer period of time. The weather didn't cooperate, so Becquerel left the crystals and film stored in a drawer for several cloudy days. Before continuing his experiments, Becquerel decided to check one of the photographic plates to make sure the chemicals were still good. To his amazement, he found that the plate had been exposed in spots where it had been near the uranium containing rocks even though some of these rocks had not been exposed to sunlight at all (see the illustration below).



Rock resting on covered film.

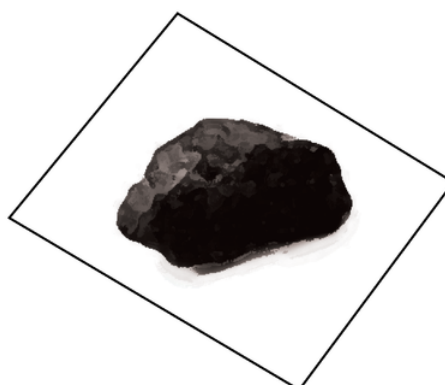

Shadow on developed film.

In later experiments, Becquerel confirmed that the radiation from the uranium had no connection with light or fluorescence, but the amount of radiation was directly proportional to the concentration of uranium in the rock. Becquerel had discovered **radioactivity**.

The Curies and Radium

One of Becquerel's assistants, a young Polish scientist named Maria Skłodowska (to become Marie Curie after she married Pierre Curie, seen in **Figure 24.1**), became interested in the phenomenon of radioactivity. With her husband, she decided to find out if chemicals other than uranium were radioactive. The Curies studied pitchblend, the residue of uranium mining, from the mining region of Joachimstahl sent from the Austrian government. From the ton of pitchblend, the Curies separated 0.10 g of a previously unknown element, radium, in the form of the compound radium chloride. This radium was many times more radioactive than uranium.

By 1902, the world was aware of a new phenomenon called radioactivity and of new elements which exhibited natural radioactivity. For this work, Becquerel and the Curies shared the 1903 Nobel Prize in Physics. For her subsequent work in radioactivity, Marie Curie won the 1911 Nobel Prize in Chemistry. She was the first female Nobel laureate and the only person ever to receive two Nobel Prizes in two different scientific categories.



FIGURE 24.1

Marie Skłodowska Curie before she moved to Paris.

Further experiments provided information about the characteristics of the penetrating emissions from radioactive substances. It was soon discovered that there were three common types of radioactive emissions. Some radiations

could pass easily through aluminum foil up to a centimeter thick, while some were stopped by the foil. The three basic types of radiation were named alpha (α), beta (β), and gamma (γ) radiation.

Eventually, scientists were able to demonstrate experimentally that the **alpha particle** is a helium nucleus (a particle containing two protons and two neutrons), the **beta particle** is a high speed, high energy electron originating from the nucleus, and **gamma rays** are a very high energy form of electromagnetic radiation (even higher energy than X-rays) of nuclear origin.

Lesson Summary

- Henri Becquerral, Marie Curie, and Pierre Curie shared the discovery of radioactivity.
- The most common emissions of radioactive elements were called alpha (α), beta (β), and gamma (γ) radiation.

Further Reading / Supplementary Links

To learn more about Marie Curie, visit:

- http://www.time.com/time/specials/packages/article/0,28804,1848817_1848816_1848808,00.html#ixzz12DfQ1top

The following webpage provides more information about the discovery of radioactivity.

- http://www.chem.duke.edu/jds/cruise_chem/nuclear/discovery.html

Review Questions

1. Match the term with its meaning in the table below.

Term	Definition
(1) alpha particle	(a) high energy electromagnetic radiation
(2) beta particle	(b) a high speed electron
(3) gamma ray	(c) a helium nucleus

24.2 Nuclear Notation

Lesson Objectives

The student will:

- read and write complete nuclear symbols.

Vocabulary

- nuclear symbol
- nucleon

Introduction

Recall that the identity of an atom is determined by the number of protons in the nucleus of the atom. In the chapter “The Atomic Theory,” the number of protons in the nucleus of the atom is also defined as the atomic number. In comparison, the mass number accounts for the total number of protons and neutrons, also called nucleons, in the nucleus of an atom. **Nucleon** is the collective name for protons and neutrons. One way to convey the mass number and the atomic number of an element is by using nuclear symbol. In this lesson, we will learn about how to read and write nuclear symbols, which you will find useful later on in this chapter.

The Complete Nuclear Symbol

The complete **nuclear symbol** contains the symbol for the element and numbers that relate to the number of protons and neutrons in that particular nucleus. To write a complete nuclear symbol, the mass number is placed at the upper left (superscript) of the chemical symbol and the atomic number is placed at the lower left (subscript) of the symbol. The complete nuclear symbol for helium-4 is drawn below.



The following nuclear symbols are for a nickel nucleus with 31 neutrons and a uranium nucleus with 146 neutrons.



In the nickel nucleus represented above, the atomic number 28 indicates the nucleus contains 28 protons, so it must contain 31 neutrons in order to have a mass number of 59. The uranium nucleus has 92 protons, as do all uranium nuclei, and this particular uranium nucleus has 146 neutrons. Another way of representing these nuclei would be Ni-59 and U-238.

Recall that atoms of an element are identical in every way but the mass numbers. This mass difference results from nuclei of the same element having a different number of neutrons. Remember that atoms with the same atomic number but a different mass number are called isotopes. Hydrogen, for example, has three isotopes, shown in the figure below. All three of hydrogen's isotopes must have one proton (to be hydrogen), but they have zero, one, or two neutrons in the nucleus.

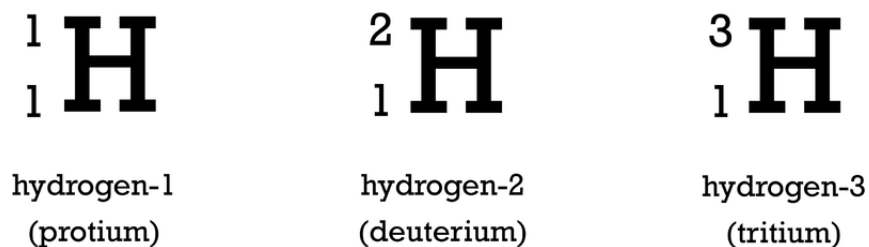

Originally, the names protium, deuterium, and tritium were suggested for the three isotopes of hydrogen. Nuclear scientists today use the names hydrogen-1, hydrogen-2, and hydrogen-3, but occasionally you will see or hear the other names.

Lesson Summary

- The complete nuclear symbol has the atomic number (number of protons) of the nucleus as a subscript at the lower left of the chemical symbol and the mass number (number of protons + neutrons) as a superscript at the upper left of the chemical symbol.

Review Questions

1. Write the complete nuclear symbol for a nucleus of chlorine that contains 17 protons and 20 neutrons.
2. Write the complete nuclear symbol for a nucleus of oxygen that contains 8 protons and 10 neutrons.
3. If a nucleus of uranium has a mass number of 238, how many neutrons does it contain?
4. In the nuclear symbol for a beta particle, what is the atomic number?
5. Is it possible for isotopes to be atoms of different elements? Explain why or why not.
6. How many neutrons are present in a nucleus whose atomic number is one and whose mass number is one?
7. Name the element of an isotope whose mass number is 206 and whose atomic number is 82.
8. How many protons and how many neutrons are present in a nucleus of lithium-7?
9. What is the physical difference between a U – 235 atom and a U – 238 atom?
10. What is the difference in the chemistry of a U – 235 atom and a U – 238 atom?

24.3 Nuclear Force

Lesson Objectives

The student will:

- compare the energy released per gram of matter in nuclear reactions to that in chemical reactions.
- express the equation for calculating the change in mass during nuclear reactions that is converted into energy.
- express the relationship between nuclear stability and the nuclei's binding energy per nucleon ratio.

Vocabulary

- binding energy
- mass defect

Introduction

There are four forces in nature that produce all interactions between objects: gravity, electromagnetic force, weak nuclear force, and strong nuclear force. The weak nuclear force is limited to the atomic nucleus and causes unstable particles and nuclei to decay. The strong nuclear force is also limited to the nucleus and binds quarks into nucleons and nucleons into nuclei. In this lesson, we will learn more about the nuclear force and the stability of the nucleus.

Nuclear Force Overcomes Proton Repulsion

A nucleus consists of some number of protons and neutrons pulled together in an extremely tiny volume. The one exception would be hydrogen-1. Since protons are positively charged and like charges repel, it is clear that protons cannot remain together in the nucleus unless there is a powerful force holding them there. The force which holds the nucleus together is generated by nuclear binding energy. We are concerned with not just the total amount of binding energy a nucleus possesses, but also with the number of nucleons present for the binding energy to hold together. It is more illuminating for us to consider the amount of **binding energy per nucleon** that a nucleus contains. The binding energy per nucleon is the total binding energy divided by the number of nucleons in the nucleus. A nucleus with a large amount of binding energy per nucleon will be held together tightly and is referred to as stable. When there is too little binding energy per nucleon, the nucleus will be less stable and may disintegrate. When a nucleus disintegrate, it comes apart violently with a tremendous release of energy in the form of heat, light, and radiation.

This video discusses binding energy, fission and nuclear force (**11a**): <http://www.youtube.com/watch?v=UkLkiXiOCWU> (2:36).

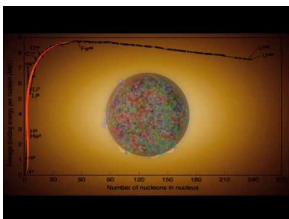

MEDIA

Click image to the left for more content.

Mass Defect Becomes Binding Energy

We know that a proton has a mass of 1.00728 daltons and a neutron has a mass of 1.00867 daltons. A helium-4 nucleus consists of two protons and two neutrons. The mass of this nucleus would be:

$$2 \times 1.00728 + 2 \times 1.00867 = 4.03190 \text{ daltons}$$

The actual mass of a helium-4 nucleus, however, is only 4.00150 daltons. It would appear that some mass has been lost when the particles formed a nucleus. This difference between the sum of the masses of the individual nucleons and the mass of the corresponding nucleus always occurs and is called **mass defect**. The mass defect in this case is 0.03040 daltons. This mass is not lost but rather converted into an energy called the binding energy. Albert Einstein first theorized that mass and energy could be converted into one another and produced the famous equation $E = mc^2$ to calculate this conversion, where E is energy in joules, m is the mass in kilograms, and c is the speed of light (3×10^8 meters/second).

Since the speed of light is squared, you can imagine that the conversion of a very small amount of mass into energy produces an immense amount of energy. If 1.00 gram of mass were converted to energy in this manner, it would produce 9.0×10^{13} joules. This amount of energy would raise the temperature of 300 million liters of water from room temperature to boiling. As a result, nuclear reactions produce a great deal more energy than chemical reactions. Chemical reactions involve the disruption of chemical bonds and can release energy on the order of 1×10^3 kJ/mol. In comparison, nuclear reactions release some of the nuclear binding energy and may convert tiny amounts of matter into energy. The energy released in a nuclear reaction has an order of magnitude of 1×10^8 kJ/mol.

Part 1 of 2 of A Funny 1950's Science Educational Cartoon Video about the Atom, the chemical elements, isotopes, electrons, protons, neutrons. The video also shows nuclear reactors and the benefits of peaceful uses of nuclear energy (**11b**): <http://www.youtube.com/watch?v=UPb0hFtd27A> (8:27).



MEDIA

Click image to the left for more content.

Part 2 of 2 of A Funny 1950's Science Educational Cartoon Video about the Atom (**11b**): <http://www.youtube.com/watch?v=ZHfO14BtNxE> (6:16).



MEDIA

Click image to the left for more content.

For an introduction to the energy from the nucleus (**11b**), see <http://www.youtube.com/watch?v=YAXpJN-gVR0> (9:28).



MEDIA

Click image to the left for more content.

More Binding Energy per Nucleon Produces Stability

It is conventional to plot the binding energy per nucleon versus the atomic mass of the nucleus. Such a graph is shown in **Figure 24.2**. The position of greatest binding energy per nucleon is held by iron-56. Nuclei both larger and smaller than iron-56 have less binding energy per nucleon and are therefore less stable. In the graph below, binding energy is measured in MeV (million electron volts). One million electron volts is equal to 1.6×10^{-13} joules. (This graph has been smoothed. The actual graph line zig zags up and down a little.)

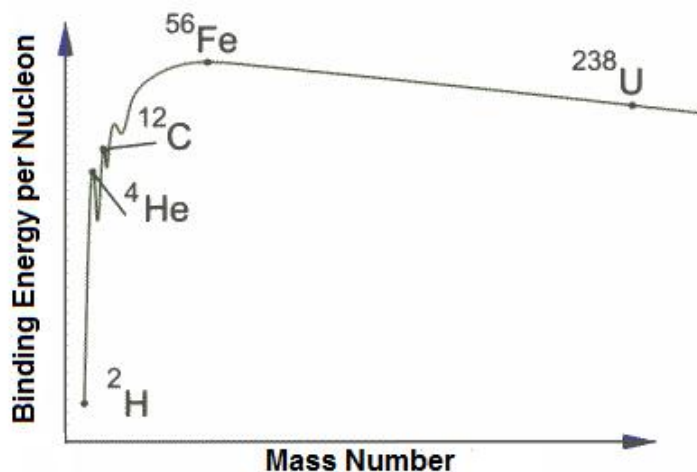

FIGURE 24.2

The graph of binding energy per nucleon for atoms between atomic number 1 and 92.

Lesson Summary

- The proton-proton repulsion in a nucleus is overcome by binding energy to hold the nucleus together.

- The sum of the masses of the individual components of a nucleus is greater than the mass of the nucleus and the “lost” mass is called mass defect.
- Much of the mass defect is converted into binding energy according to the Einstein equation $E = mc^2$.
- The stability of a nucleus is determined by the amount of binding energy present for each nucleon.
- Nuclei with lower binding energy per nucleon may disintegrate.
- The nucleus with the greatest binding energy per nucleon is iron-56.

Further Reading / Supplementary Links

This website provides more information about strong nuclear forces.

- <http://www.wisegeek.com/what-is-the-strong-nuclear-force.htm>

Review Questions

1. Iron-56 is a very stable nucleus while cobalt-60 is an unstable nucleus. Which nucleus would you expect to have more binding energy per nucleon?
2. Calculate the mass defect and binding energy for a mole of carbon-14 given the data below.

The molar mass of carbon-14 is 14.003241 g/mol.

The molar mass of a proton is 1.007825 g/mol.

The molar mass of a neutron is 1.008665 g/mol.

Mass is converted into energy by multiplying mass by the speed of light squared, $E = mc^2$.

The speed of light is 3.00×10^8 m/s.

$\text{kg} \cdot \text{m}^2/\text{s}^2 = \text{joules}$

24.4 Nuclear Disintegration

Lesson Objectives

The student will:

- list some naturally occurring elemental isotopes that are radioactive.
- describe the three most common emissions during natural nuclear decay.
- express the changes in the atomic number and mass number of a radioactive nuclei when an alpha particle, a beta particle, or a gamma ray is emitted.
- define quarks.
- express the number of quarks that make up a proton or neutron.

Vocabulary

- alpha decay
- beta decay
- quark

Introduction

Under certain conditions, less stable nuclei alter their structure to become more stable. Unstable nuclei that are larger than iron-56 spontaneously disintegrate by ejecting particles. This process of decomposing to form a different nucleus is called radioactive decay. Many nuclei are radioactive; that is, they decompose by emitting particles and in doing so, become a different nucleus. All nuclei with 84 or more protons are radioactive, and many elements with less than 84 protons have both stable and unstable isotopes.

Types of Radioactive Decay

In natural radioactive decay, three common emissions occur. When these emissions were originally observed, scientists were unable to identify them and named them alpha (α) particles, beta (β) particles, and gamma (γ) rays. Some time later, alpha particles were identified as helium-4 nuclei, beta particles as electrons, and gamma rays as a form of high energy electromagnetic radiation of nuclear origin.

This video provides an overview of Alpha, Beta, Gamma Decay and Positron Emission (**11d**): <http://www.youtube.com/watch?v=3koOwozY4oc> (17:02).

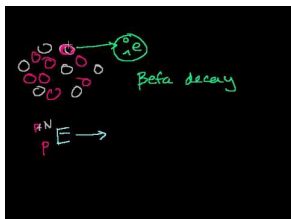

MEDIA

Click image to the left for more content.

Alpha Decay

The nuclear disintegration process that emits alpha particles is called **alpha decay**. An example of a nucleus that undergoes alpha decay is uranium-238. The alpha decay of U-238 is:

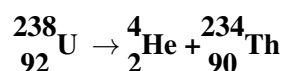

In nuclear equations, it is required that the sum of the mass numbers (top numbers) on the reactant side equal the sum of the mass numbers on the product side. The same is true for the atomic numbers (bottom numbers) on the two sides. In this equation,

$$\text{atomic number: } 92 = 2 + 90$$

$$\text{mass number: } 238 = 4 + 234.$$

Therefore, the equation is balanced.

Another alpha particle producer is thorium-230.

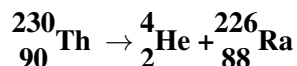

Confirm that this equation is correctly balanced.

Beta Decay

Another common decay process is beta particle production, or **beta decay**. Nuclei do not contain electrons and yet during beta decay, an electron is emitted from a nucleus. At the same time that the electron is being ejected from the nucleus, a neutron is becoming a proton. It is tempting to picture this as a neutron breaking into two pieces with the pieces being a proton and an electron. This is not, however, what actually happens. More details about the decay process will be given at the end of this section.

In order to insert an electron into a nuclear equation and have the numbers add up properly, an atomic number and a mass number have to be assigned to an electron. The mass number assigned to an electron is zero, which is reasonable since an electron contains no protons and no neutrons. The atomic number assigned to an electron is negative one because that allows a nuclear equation containing an electron to balance atomic numbers. Therefore, the nuclear symbol representing an electron (beta particle) is

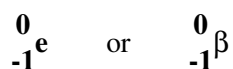

Thorium-234 is a nucleus that undergoes beta decay. Here is the nuclear equation for this beta decay:

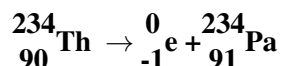

Note that both the mass numbers and the atomic numbers add up properly:

$$\text{atomic number: } 90 = -1 + 91$$

$$\text{mass number: } 234 = 0 + 234$$

The mass numbers of the original nucleus and the new nucleus are the same because a neutron has been lost and a proton has been gained, so the sum of protons plus neutrons remains the same. The atomic number in the process has been increased by one since the new nucleus has one more proton than the original nucleus. In this beta decay, a thorium-234 nucleus has become a protactinium-234 nucleus. Protactinium-234 is also a beta emitter and produces uranium-234.

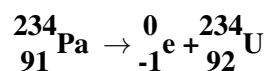

Once again, the atomic number increases by one and the mass number remains the same. You should confirm that the equation is correctly balanced.

Protons and Neutrons are Made Up of Quarks

Protons and neutrons are not fundamental particles like electrons are. Instead, protons and neutrons are composed of more fundamental particles called quarks. **Quarks** are fundamental particles like electrons in the sense that they cannot be broken into smaller pieces, but quarks and electrons are otherwise not similar. Quarks come in six different types (particle physicists call them flavors). The six flavors of quarks are named *up*, *down*, *top*, *bottom*, *strange*, and *charmed*. Protons and neutrons are composed of a combination of *up* and *down* quarks. The *up* quark carries a charge of $+2/3$ and the *down* quark carries a charge of $-1/3$. A proton is composed of two *up* quarks and one *down* quark, resulting in an overall $+2/3 + 2/3 - 1/3 = +1$ charge. A neutron is composed of one *up* quark and two *down* quarks, resulting in an overall charge of $+2/3 - 1/3 - 1/3 = 0$. With this information, you can see that a neutron is *not* composed of a proton and an electron. The beta particle produced during beta decay is created in the process of a neutron decaying to a proton.

For an introduction to quarks (**11g**), see <http://www.youtube.com/watch?v=TGrDj5vFefQ> (3:59).

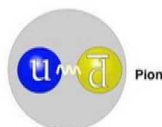

MEDIA

Click image to the left for more content.

Gamma Radiation

Gamma ray production accompanies nuclear reactions of all types. In the alpha decay of U-238, two gamma rays of different energies are emitted in addition to the alpha particle.

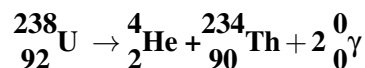

Virtually all of the nuclear reactions in this chapter emit gamma rays, but for simplicity the gamma rays are generally not shown.

Decay Series

A radioactive nucleus decays in order to become more stable. Often, a radioactive nucleus cannot reach a stable state through a single decay. In such cases, a series of decays will occur until a stable nucleus is formed. The decay of U-238 is an example of this (Table 24.1). The U-238 decay series starts with U-238 and goes through fourteen separate decays to finally reach a stable nucleus, Pb-206. There are similar decay series for U-235 and Th-232. The U-235 series ends with Pb-207, and the Th-232 series ends with Pb-208.

TABLE 24.1: U-238 Decay Series

	Nucleus	Type of Decay	Product
U-238	α	Th-234	
Th-234	β	Pa-234	
Pa-234	β	U-234	
U-234	α	Th-230	
Th-230	α	Ra-226	
Ra-226	α	Rn-222	
Rn-222	α	Po-218	
Po-218	α	Pb-214	
Pb-214	β	Bi-214	
Bi-214	β	Po-214	
Po-214	α	Pb-210	
Pb-210	β	Bi-210	
Bi-210	β	Po-210	
Po-210	α	Pb-206	

Several of the radioactive nuclei are present in the radioactive decay series because they are produced during the decay. That is to say, there may have been radon on the earth at the time of its formation, but that original radon would have completely decayed by this time. The radon that is present now is present because it was formed in a decay series.

Lesson Summary

- A nuclear reaction is one that changes the structure of the nucleus of an atom.

- The atomic numbers and mass numbers in a nuclear equation must be balanced.
- Protons and neutrons are made up of quarks.
- The two most common modes of natural radioactivity are alpha decay and beta decay.
- Most nuclear reactions emit energy in the form of gamma rays.

Further Reading / Supplementary Links

Short animation showing the bending of α , β , and γ radiation under the influence of electrically charged plates.

Review Questions

1. Write the nuclear equation for the alpha decay of radon-198.
2. Write the nuclear equation for the beta decay of uranium-237.
3. There are six known quarks: up, down, charmed, strange, top, and bottom. Protons and neutrons are each made of only up and down quarks, and they are made of three quarks each. The up quark carries a charge of $+\frac{2}{3}$, and the down quark carries a charge of $-\frac{1}{3}$. Determine by the final charge on the proton and neutron what combination of three up and down quarks are required to make a proton and what combination will make a neutron.
4. Only one particle is missing from this equation. What are its atomic and mass numbers?

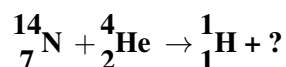

5. To what element does the missing particle in question #1 belong?
6. When a U-235 nucleus is struck by a neutron, the nucleus may be split into Ce-144 and Sr-90 nuclei, also emitting four electrons and two neutrons. Write the equation for this nuclear reaction.
7. Complete the following nuclear equations by supplying the missing particles.

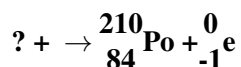
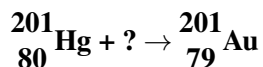
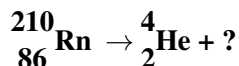
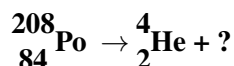
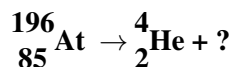

24.5 Nuclear Equations

Lesson Objectives

The student will:

- define and give examples of fission and fusion.
- classify nuclear reactions as fission or fusion.

Vocabulary

- artificial radioactivity
- chain reaction
- critical mass
- fission
- fusion
- natural radioactivity

Introduction

Atomic nuclei with an inadequate amount of binding energy per particle are unstable and occasionally disintegrate in an organized fashion. Such disintegrations are referred to as **natural radioactivity**. It is also possible for scientists to smash nuclear particles together and cause nuclear reactions between normally stable nuclei. These disintegrations are referred to induced or **artificial radioactivity**. None of the elements above atomic number 92 on the periodic table occur on earth naturally. They are all products of induced radioactivity and are considered man-made.

Fission and Chain Reactions

Nuclei that are larger than iron-56 can become smaller and more stable in the process. These large nuclei undergo nuclear reactions in which they break up into two or more smaller nuclei. These reactions are called **fission** reactions. Nuclear fission was discovered in the late 1930s when U-235 nuclides were bombarded with neutrons and observed to split into two smaller-mass nuclei.

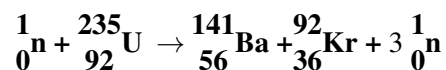

The products shown are only one of many sets of products from the disintegration of a U-235 nucleus. Over 35 different elements have been observed in the fission products of U-235.

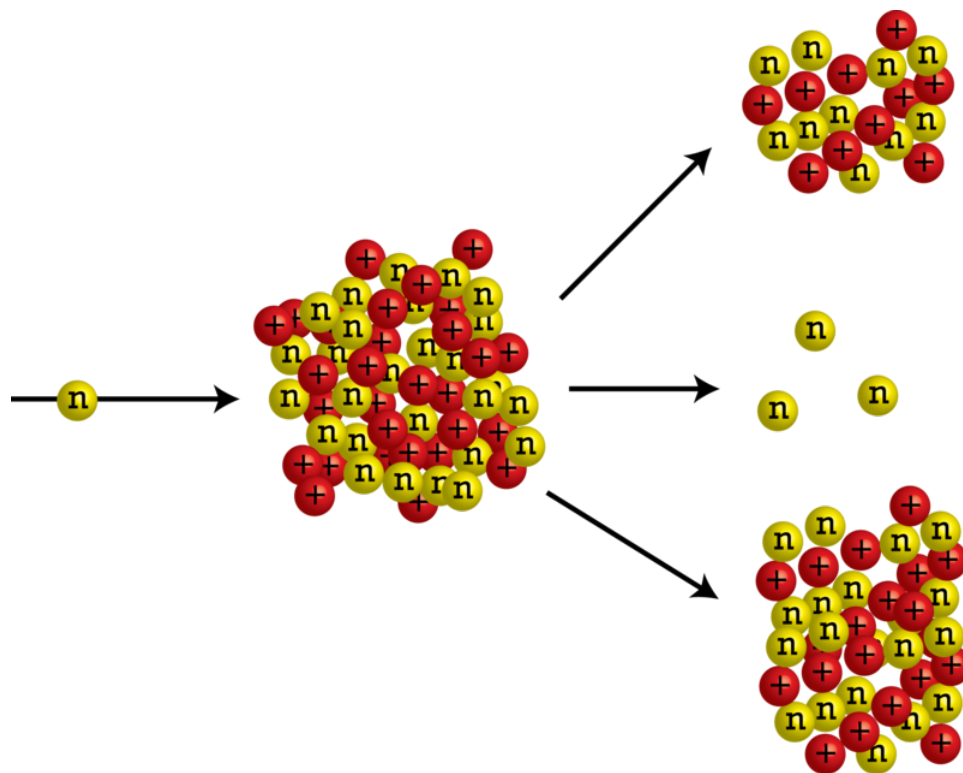

When a U-235 nucleus captures a neutron, it undergoes fission producing two lighter nuclei and three free neutrons (illustrated in the image above). The production of the free neutrons makes it possible to have a self-sustaining fission process – a nuclear **chain reaction**. If at least one of the neutrons goes on to cause another U-235 to disintegrate, the fission will be self-sustaining. If none of the neutrons goes on to cause another disintegration, the process dies out. If the mass of fissionable material is too small, the neutrons escape from the mass without causing another reaction, and the reaction is said to be subcritical. When the mass of fissionable material is large enough, at least one of the neutrons will cause another reaction, and the process will continue at a steady rate. This process is said to be critical.

If enough mass is present for the reaction to escalate rapidly, the heat buildup causes a violent explosion. This situation is called supercritical. The amount of mass necessary to maintain a chain reaction differs with each fissionable material and is called that material's **critical mass**. When the critical mass is reached, the neutron will always cause another disintegration.

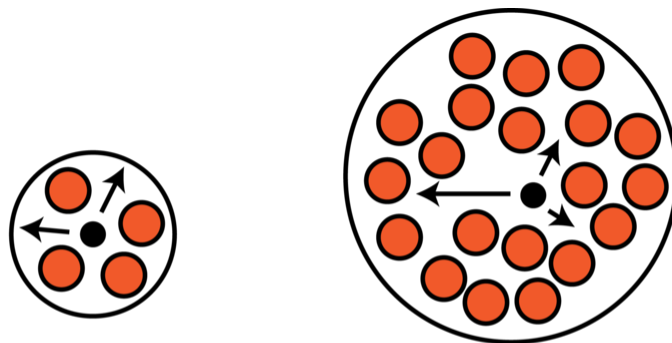

When the mass is small enough, the neutron may escape without causing another reaction. When the mass is large, however, the neutron is very unlikely to escape.

For a demonstration of the mouse trap model of a chain reaction, see <http://www.youtube.com/watch?v=HmbzJGf90Xc> (1:17).



MEDIA

Click image to the left for more content.

Natural and Artificial Radioactivity

Recall from the introduction that there are several ways in which nuclei can undergo reaction and change their identity. Some nuclei are unstable and spontaneously emit particles and electromagnetic radiation in a process known as natural radioactivity.

It is also possible to cause nuclear disintegration by striking a nucleus with another particle in a process called artificial radioactivity. Ernest Rutherford produced the first induced or artificial transmutation of elements by bombarding a sample of nitrogen gas with alpha particles.

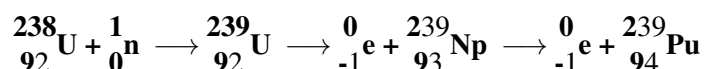

Irene Joliet-Curie, the daughter of Pierre and Marie Curie, carried out a transmutation that produced an unstable (radioactive) nucleus from a stable nucleus. She bombarded aluminum with alpha particles, but even after the bombardment was stopped, the product continued to emit radiation. It was determined that the alpha particle bombardment transmuted aluminum-27 nuclei to phosphorus-30 nuclei. The phosphorus-30 is a positron emitter. Positrons are subatomic particles with the same mass as an electron but carry a positive one (+1) charge instead of negative one (−1).

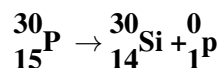
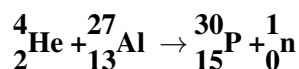

This video is an introduction to natural transmutations (11c): <http://www.youtube.com/watch?v=I7WTQD2xYtQ> (9:11).

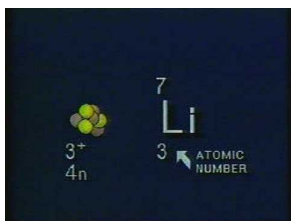

MEDIA

Click image to the left for more content.

Fusion

Nuclei that are smaller than iron-56 can become larger in order to be more stable. These nuclei undergo a nuclear reaction in which smaller nuclei join together to form a larger nucleus. Such nuclear reactions are called **fusion** reactions. The nuclear reaction shown below is a reaction in which a lithium-7 nucleus combines with a hydrogen-1 nucleus to produce two helium-4 nuclei and a considerable amount of energy.

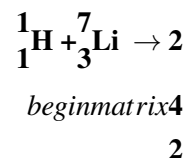

He + energy

The combined mass of the lithium and hydrogen nuclei is 8.02329 daltons, and the combined mass of the two helium nuclei is 8.00520 daltons. The mass lost is 0.01809 daltons and is accounted for in the energy that is released.

Of particular interest are fusion reactions in which hydrogen nuclei combine to form helium. Hydrogen nuclei are positively charged and repel each other. The closer the particles come, the greater is the force of repulsion. In order for fusion reactions to occur, the hydrogen nuclei must have extremely high kinetic energies in order for the velocities to overcome the forces of repulsion. These kinetic energies only occur at extreme temperatures such as those that occur in the cores of the sun and other stars (see **Figure 24.3**). Nuclear fusion is the power source for the stars where the necessary temperature to ignite the fusion reaction is provided by massive gravitational pressure.

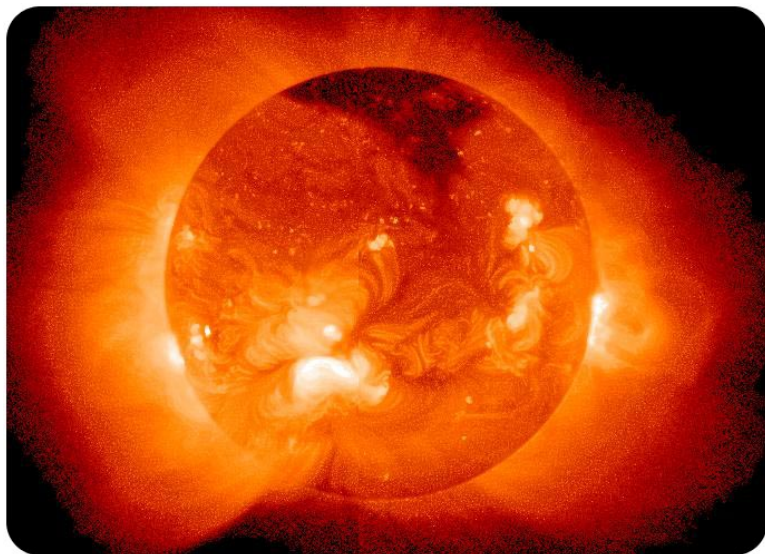
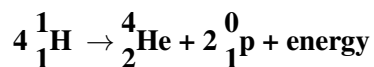

FIGURE 24.3

The energy that comes from the sun and other stars is produced by fusion.

The conversion of hydrogen to helium in the sun requires several steps, but the net result is the fusion of four hydrogen—1 nuclei into one helium—4 nucleus.



In stars more massive than our sun, fusion reactions involving carbon and nitrogen are possible. These reactions produce more energy than hydrogen fusion reactions.

These videos chronicle the search for cold fusion (**1m, 1n IE Stand.**): <http://www.youtube.com/watch?v=vrs01XsmpLI> (10:01), <http://www.youtube.com/watch?v=WQ1oghHOjHA> (10:00), http://www.youtube.com/watch?v=4u_-h6IGb6E (10:00), <http://www.youtube.com/watch?v=6mBu7-y2mM> (10:00), <http://www.youtube.com/watch?v=QqiJtv5DR-4> (8:52).



MEDIA

Click image to the left for more content.



MEDIA

Click image to the left for more content.



MEDIA

Click image to the left for more content.



MEDIA

Click image to the left for more content.



MEDIA

Click image to the left for more content.

Lesson Summary

- Nuclear fission refers to the splitting of atomic nuclei.
- Nuclear fusion refers to the joining together to two or more smaller nuclei to form a single nucleus.

Further Reading / Supplementary Links

This website has several videos that show the tremendous effects of a nuclear explosion.

- http://www.atomicarchive.com/Movies/index_movies.shtml

Review Questions

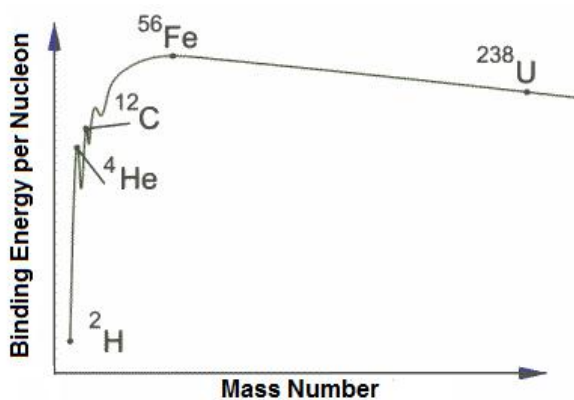

1.

Using information in the chart above, if a carbon-12 nuclei were to be transmuted into other nuclei that were more stable, would this more likely be accomplished by fission or by fusion?

24.6 Radiation Around Us

Lesson Objectives

The student will:

- compare qualitatively the ionizing and penetration power of α , β , and γ particles.
- calculate the amount of radioactive material that will remain after an integral number of half-lives.
- describe how carbon-14 is used to determine the age of carbon containing objects.

Vocabulary

- background radiation
- half-life
- ionizing power
- penetration power

Introduction

All of us are subjected to a certain amount of ionizing radiation every day. This radiation is called **background radiation** and comes from a variety of natural and artificial radiation sources. Approximately 82% of background radiation comes from natural sources. These include 1) sources in the earth and naturally occurring radioactive elements which are incorporated in building materials and in the human body, 2) sources from space in the form of cosmic rays, and 3) sources in the atmosphere, such as radioactive radon gas released from the earth and radioactive atoms like carbon-14 produced in the atmosphere by bombardment from high-energy cosmic rays.

Background Radiation

Approximately 15% of background radiation comes from medical X-rays and nuclear medicine. The remaining 3% of background radiation comes from man-made sources such as: smoke detectors, luminous dials and signs, radioactive contamination due to historical nuclear weapons testing, normal operation of facilities used for nuclear power and scientific research, emissions from burning fossil fuels (primarily coal-burning power plants without ash-capture facilities), and emissions from the improper disposal of radioactive materials used in nuclear medicine.

It is recommended that individuals limit exposure to ionizing radiation as much as possible. To this goal, the medical profession has significantly reduced the number of X-rays recommended: skin tests for tuberculosis are recommended over X-rays, and most dentists recommend dental X-rays every other check-up instead of every check-up.

The Ionizing and Penetration Power of Radiation

With all the radiation from natural and man-made sources, we should be quite reasonably concerned about how all the radiation might affect our health. The damage to living systems done by radioactive emissions is when the particles or rays strike and alter tissue, cells, or molecules. These interactions can alter molecular structure and function, causing cells to no longer carry out their proper function and molecules, such as DNA, to no longer carry the appropriate information.

Large amounts of radiation are very dangerous, even deadly. The ability of radiation to damage molecules is analyzed in terms of what is called **ionizing power**. When a radiation particle interacts with atoms, the interaction can cause the atom to lose electrons and thus become ionized. The ionizing power of the radiation reflects the likelihood that damage will occur by such an interaction. Much of the threat from radiation is involved with the ease or difficulty of protecting oneself from the particles. The ability of each type of radiation to pass through matter is expressed in terms of **penetration power**. The more material the radiation can pass through, the greater the penetration power and the more dangerous they are.

Comparing the three common types of ionizing radiation, alpha particles have the greatest mass. Alpha particles have approximately four times the mass of a proton or neutron and approximately 8,000 times the mass of a beta particle. Because of the large mass of the alpha particle, it has the highest ionizing power and the greatest ability to damage tissue. The large size of alpha particles, however, makes them less able to penetrate matter. They collide with molecules very quickly when striking matter, add two electrons, and become a harmless helium atom. Alpha particles have the least penetration power and can be stopped by a thick sheet of paper. They are also stopped by the outer layer of dead skin on people. This may seem to be enough to remove the threat from alpha particles, but this is only true if the radiation comes from external sources. In a situation like a nuclear explosion or some sort of nuclear accident where radioactive emitters are spread around in the environment, the emitters can be inhaled or taken in with food or water. Once the alpha emitter is inside you, you will have no protection at all.

Beta particles are much smaller than alpha particles. Consequently, they have much less ionizing power (less ability to damage tissue), but their small size gives them much greater penetration power. Most resources say that beta particles can be stopped by a one-quarter inch thick sheet of aluminum. Once again, however, the greatest danger occurs when the beta emitting source gets inside of you.

Gamma rays are energy that has no mass or charge. Gamma rays have tremendous penetration power and require several inches of dense material (like lead) to shield them. Gamma rays may pass all the way through a human body without striking anything. They are considered to have the least ionizing power and the greatest penetration power.

When researching thicknesses and materials required to stop various types of radiation, different estimates are encountered. There are apparently two reasons for this: 1) some estimates are based on stopping 95% of beta particles while other estimates are based on stopping 99% of beta particles, and 2) different beta particles emitted during nuclear reactions may have very different energies – some very high energy beta particles may not be stopped by the normal barrier.

For a lecture about types of nuclear decay including the ionizing and penetration power of the three major types of radioactive emissions (**11e**), see <http://www.youtube.com/watch?v=aEBGE1Nm7vc> (7:57).

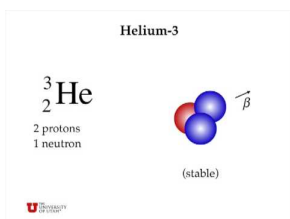

MEDIA

Click image to the left for more content.

Definition of Half-Life

During natural radioactive decay, not all atoms of an element are instantaneously changed to atoms of another element. The decay process takes time, and there is value in being able to express the rate at which a process occurs. In chemical reactions as well as radioactive decay, a useful concept is the **half-life**, which is the time required for half of the starting material to be consumed. Half-lives can be calculated from measurements on the change in mass of a nucleus and the time it takes to occur. For a particular group of radioactive nuclei, it is not possible to know which nuclei will disintegrate or when they will disintegrate. The only thing we know is that in the time of that substance's half-life, half of the original nuclei will disintegrate.

Selected Half-Lives

The half-lives of many radioactive isotopes have been determined and found to range from extremely long half-lives of 10 billion years to extremely short half-lives of fractions of a second (Table 24.2).

TABLE 24.2: Table of Selected Half-Lives

Element	Mass Number	Half-Life	Element	Mass Number	Half-Life
Uranium	238	4.5 billion years	Californium	251	800 years
Neptunium	240	1 hour	Nobelium	254	3 seconds
Plutonium	243	5 hours	Carbon	14	5,770 years
Americium	246	25 minutes	Carbon	16	0.74 seconds

The quantity of radioactive nuclei at any given time will decrease to half as much in one half-life. For example, if there were 100 g of Cf – 251 in a sample at some time, after 800 years, there would be 50 g of Cf – 251 remaining. After another 800 years, there would only be 25 g remaining.

Half-life is defined and explained in the first video (11f) <http://www.youtube.com/watch?v=9REPnibO4IQ> (12:31).

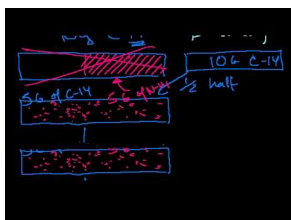

MEDIA

Click image to the left for more content.

The second video is an introduction to exponential decay (11f, IE 1e) <http://www.youtube.com/watch?v=HTDop6eEsaA> (9:19).

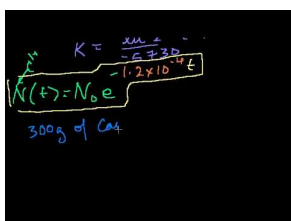

MEDIA

Click image to the left for more content.

Radioactive Dating

An ingenious application of half-life studies established a new science of determining ages of materials by half-life calculations. For geological dating, the decay of U-238 can be used. The half-life of U-238 is 4.5×10^9 years. The end product of the decay of U-238 is Pb-206. After one half-life, a 1.00 gram sample of uranium will have decayed to 0.50 grams of U-238 and 0.43 grams of Pb-206. By comparing the amount of U-238 to the amount of Pb-206 in a sample of uranium mineral, the age of the mineral can be estimated. Present day estimates for the age of the Earth's crust from this method is at least 4 billion years.

Organic material is radioactively dated using the long-lived carbon-14. This method of determining the age of organic material was given the name radiocarbon dating. The carbon dioxide consumed by living systems contains a certain concentration of $^{14}\text{CO}_2$. When the organism dies, the acquisition of carbon-14 stops, but the decay of the C-14 in the body continues. As time goes by, the ratio of C-14 to C-12 decreases at a rate determined by the half-life of C-14. Using half-life equations, the time since the organism died can be calculated. These procedures have been used to determine the age of organic artifacts and determine, for instance, whether art works are real or fake.

Lesson Summary

- 82% of background radiation comes from natural sources.
- Approximately 15% of background radiation comes from medical X-rays and nuclear medicine. The remaining 3% of background radiation comes from man-made sources.
- Of the three common nuclear emissions, alpha particles produce the greatest damage to cells and molecules but are the least penetrating. Gamma rays are the most penetrating but generate the least damage.
- C-14 dating procedures have been used to determine the age of organic artifacts.

Further Reading / Supplementary Links

The following website provides more information about background radiation.

- <http://www.hps.org/publicinformation/ate/cat10.html>

The website below displays a map that shows the amount of environmental radiation across the United States.

- <http://www.radiationnetwork.com/RadiationNetwork.htm>

Review Questions

1. Which of the three common emissions from radioactive sources requires the heaviest shielding?
2. The half-life of radium-226 is about 1600 years. How many grams of a 2.00 gram sample will remain after 4800 years?
3. Sodium-24 has a half-life of about 15 hours. How much of an 16.0 grams sample of sodium-24 will remain after 60.0 hours?
4. A radioactive isotope decayed from 24.0 grams to 0.75 grams in 40.0 years. What is the half-life of the isotope?
5. What nuclide is commonly used in the dating of organic artifacts?

6. Why does an ancient wood artifact contain less carbon-14 than a piece of lumber sold today?
7. The half-life of C-14 is about 5,700 years. An organic relic is found to contain C-14 and C-12 in a ratio that is about one-eighth as great as the ratio in the atmosphere. What is the approximate age of the relic?
8. Even though gamma rays are much more penetrating than alpha particles, it is the alpha particles that are more likely to cause damage to an organism. Explain why this is true.
9. The radioactive isotope calcium-47 has been used in the study of bone metabolism; radioactive iron-59 has been used in the study of red blood cell function; iodine-131 has been used in both diagnosis and treatment of thyroid problems. Suggest a reason why these particular elements were chosen for use with the particular body function.

24.7 Applications of Nuclear Energy

Lesson Objectives

The student will:

- trace the energy transfers that occur in a nuclear power reactor from the binding energy of the nuclei to the electricity that leaves the plant.
- define breeder reactor.
- list some medical uses of nuclear energy.

Vocabulary

- control rod
- fissile
- fissionable
- Geiger counter
- moderator

Introduction

Perhaps the two better known applications of nuclear energy are nuclear weapons and electricity generation. Nuclear energy, however, has many other applications. Radioactivity has huge applications in scientific research, several fields of medicine both in terms of imaging and in terms of treatment, industrial processes, some very useful appliances, and even in agriculture.

Fission Reactors

A nuclear reactor is a device in which a nuclear chain reaction is carried out at a controlled rate. When the controlled chain reaction is a fission reaction, the reactor is called a fission reactor. Fission reactors are used primarily for the production of electricity, although there are a few fission reactors used for military purposes and for research. The great majority of electrical generating systems all follow a reasonably simple design, as seen in the image below. The electricity is produced by spinning a coil of wire inside a magnetic field. When the loop is spun, electric current is produced. The direction of the electric current is in one end of the loop and out the other end. The machine built to accomplish this task is called an electric generator.

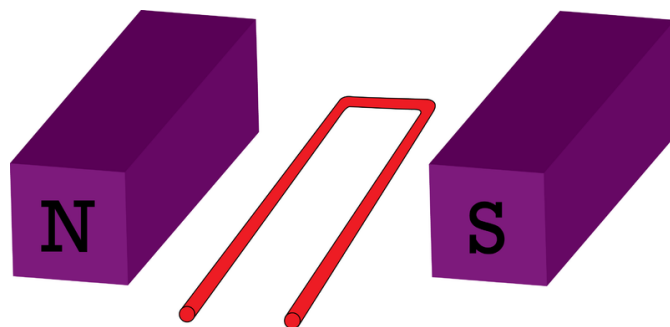

Another machine usually involved in the production of electric current is a turbine. Although actual turbines can get very complicated, the basic idea is simple. A turbine is a pipe with many fan blades attached to an axle that runs through the pipe. When a fluid (air, steam, water) is forced through the pipe, it spins the fan blades, which in turn spin the axle. To generate electricity, the axle of a turbine is attached to the loop of wire in a generator. If a fluid is forced through the turbine, the fan blades turn the turbine axle, which turns the loop of wire inside the generator, thus generating electricity. A steam turbine is illustrated in the image below.

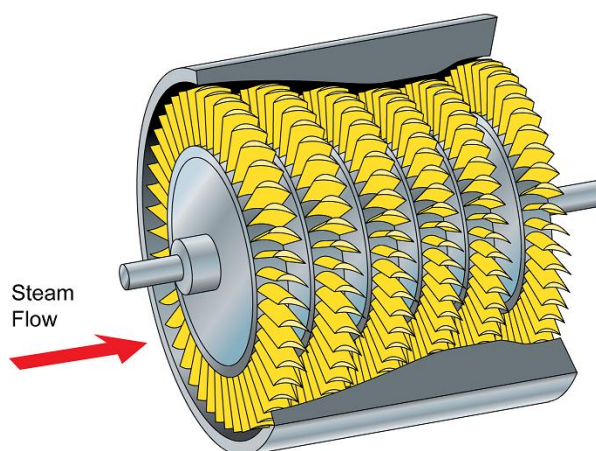

The essential difference in various kinds of electrical generating systems is the method used to spin the turbine. For a wind generator, the turbine is a windmill. In a geothermal generator, steam from a geyser is forced through the turbine. In hydroelectric generating plants, water falling over a dam passes through the turbine and spins it. In fossil fuel (coal, oil, natural gas) generating plants, the fossil fuel is burned to boil water into steam that passes through the turbine and makes it spin. In a fission reactor generating plant, a fission reaction is used to boil the water into the steam that passes through the turbine. Once the steam is generated by the fission reaction, a nuclear power plant is essentially the same as a fossil fuel plant.

Naturally occurring uranium is composed almost entirely of two uranium isotopes. It contains more than 99% uranium-238 and less than 1% uranium-235. It is the uranium-235, however, that is **fissionable** (will undergo fission). In order for uranium to be used as fuel in a fission reactor, the percentage of uranium-235 must be increased, usually to about 3%. Uranium in which the U-235 content is more than 1% is called enriched uranium. Somehow, the two isotopes must be separated so that enriched uranium is available for use as fuel. Separating the isotope by chemical means (chemical reactions) is not successful because the isotopes have exactly the same chemistry. The only essential difference between U-238 and U-235 is their atomic masses; as a result, the two isotopes are separated by a physical means that takes advantage of the difference in mass.

Once the supply of U-235 is acquired, it is placed in a series of long cylindrical tubes called fuel rods. These fuel cylinders are bundled together with **control rods** (see diagram below) made of neutron-absorbing material. In the United States, the amount of U-235 in all the fuel rods taken together is adequate to carry on a chain reaction but is less than the critical mass. The amount of heat generated by the chain reaction is controlled by the rate at which

the nuclear reaction occurs. The rate of the nuclear reaction is dependent on how many neutrons are emitted by one U-235 nuclear disintegration *and* how many strike a new U-235 nucleus to cause another disintegration. The purpose of the control rods is to absorb some of the neutrons and thus stop them from causing further disintegrations. The control rods can be raised or lowered into the fuel rod bundle. When the control rods are lowered all the way into the fuel rod bundle, they absorb so many neutrons that the chain reaction essentially stops. When more heat is desired, the control rods are raised so that the chain reaction speeds up and more heat is generated. The control rods are operated in a fail-safe system so that power is necessary to hold them up. During a power failure, gravity will pull the control rods down to shut off the system.

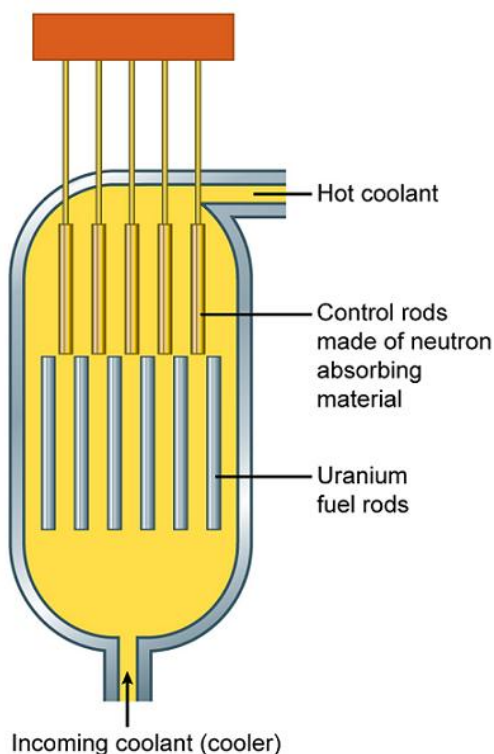

U-235 nuclei can capture neutrons and disintegrate more efficiently if the neutrons are moving slower than the speed at which they are released. Fission reactors use a **moderator** surrounding the fuel rods to slow down the neutrons. Water is not only a good coolant but also a good moderator, so a common type of fission reactor has the fuel core submerged in a huge pool of water. This type of reaction is called a light water reactor or LWR. All public electricity generating fission reactors in the United States are LWRs.

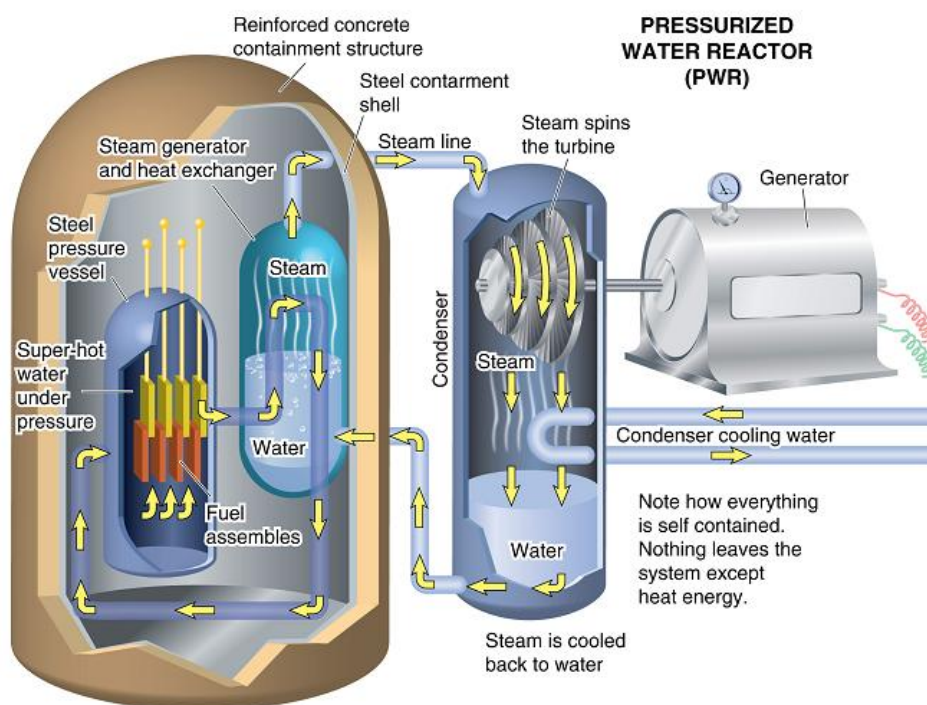

You can follow the operation of an electricity-generating fission reactor in the image above. The reactor core is submerged in a pool of water. The heat from the fission reaction heats the water, which is pumped into a heat exchange container. There the heated water boils the water in the heat exchanger. The produced steam is forced through a turbine that spins a generator and produces electricity. After the water passes through the turbine, it is condensed back to liquid water and pumped back to the heat exchanger.

There are 103 nuclear power plants operating in the U.S. deliver approximately 19.4% of American electricity with zero greenhouse gas emission. In comparison, there are 600 coal-burning electric plants in the US delivering 48.5% of American electricity and producing 2 billion tons of CO₂ annually, accounting for 40% of U.S. CO₂ emissions and 10% of global emissions. These plants have been operating for approximately 40 years. During this time, there has never been a single injury or death due to radiation in any public nuclear power plant in the U.S. There has been only one serious accident that took place in 1979, when there was a reactor core meltdown at Pennsylvania's Three Mile Island nuclear power plant. The concrete containment structure (six feet thick walls of reinforced concrete), however, did what it was designed to do – prevent radiation from escaping into the environment. Although the reactor was shut down for years, there were no injuries or deaths among nuclear workers or nearby residents.

Breeder Reactors

U-235 is the only naturally occurring fissile isotope, and it constitutes less than 1% of naturally occurring uranium. A **fissile** substance is a substance capable of sustaining a chain reaction of nuclear fission. It has been projected that the world's supply of U-235 will be exhausted in less than 200 years. It is possible, however, to convert U-238 to a fissionable isotope that will function as a fuel for nuclear reactors. The fissionable isotope is plutonium-239 and is produced by the following series of reactions:

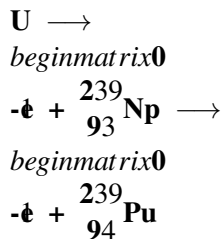
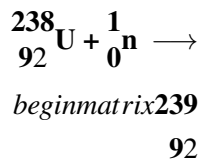

The final product from this series of reactions is plutonium-239, which has a half-life of 24,000 years and is another nuclear reactor fuel. This series of reactions can be made to occur inside an operating nuclear reactor by replacing some of the control rods with rods of U-238. As the nuclear decay process proceeds inside the reactor, it produces more fuel than it uses. It would take about 20 such breeder reactors to produce enough fuel to operate one addition reactor. The use of breeder reactors would extend the fuel supply a hundred fold. The problem with breeder reactors, however, is that plutonium is an extremely deadly poison. Furthermore, unlike ordinary fission reactors, it is possible for out-of-control breeder reactors to explode. None of the civilian nuclear power plants in the U.S. are breeder reactors.

Radiation Detectors

A variety of methods have been developed to detect nuclear radiation. One of the most commonly used instruments for detecting radiation is the **Geiger counter**.

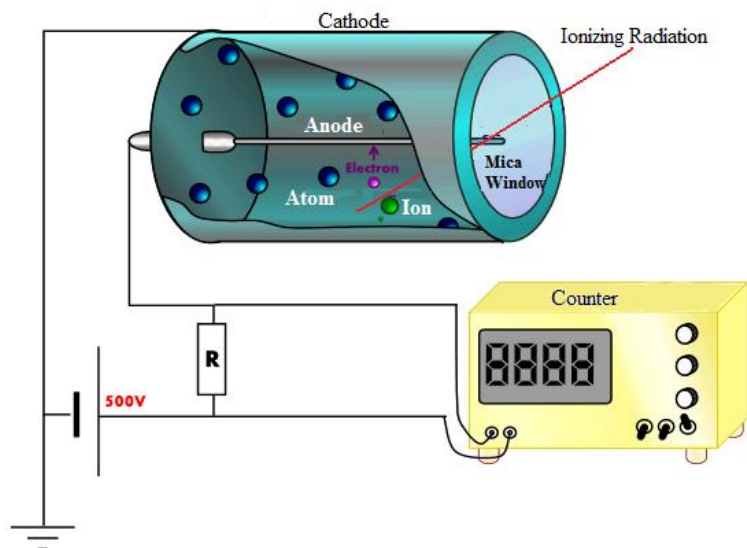
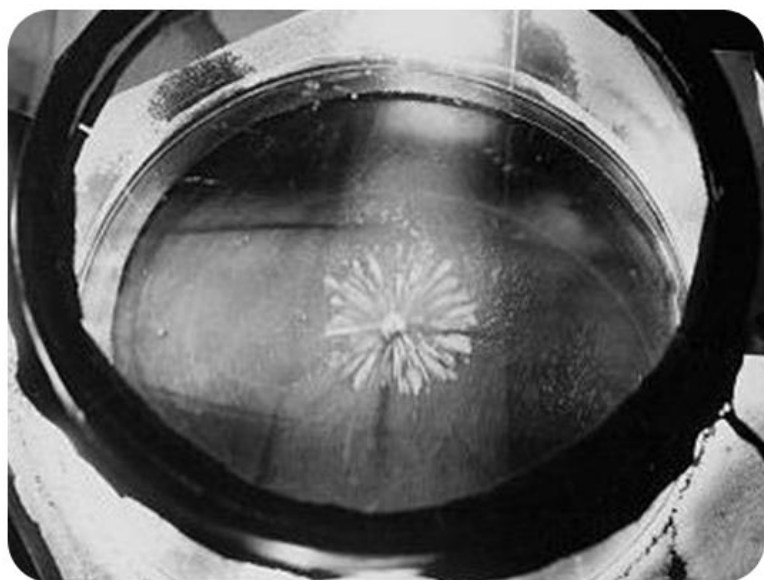

FIGURE 24.4

A Geiger counter.

The detecting component of the Geiger counter is the Geiger-Muller tube. This tube is a cylinder filled with an inert gas, and it has a window in one end made of porous material that will not allow the inert gas to escape but will allow radiation particles to enter. A conducting wire extends into the center of the tube and is electrically insulated from the tube where it passes through the wall. Electric current, however, does not flow because the inert gas does not conduct electricity and the circuit is not complete. When a radiation particle enters the tube through the window, the particle creates a line of ionized gas particles along its path through the tube. The line of ions does conduct electric current, so an electric current will flow along the ionized path. The ions only exist for a very short period because the ions of inert gas will quickly regain the lost electrons and become atoms again, which do not conduct. The result is a very short burst of electric current whenever a radiation particle passes through the tube. The control box provides the electric potential for the tube and also provides some means for demonstrating the burst of current. Some machines simply make a clicking sound for each burst of current, while others may provide a dial or a digital meter.

Other methods used for the detection of nuclear radiation include: 1) scintillation counters – a screen coated with a material that gives off a small flash of light when struck by a particle, 2) cloud chambers (see **Figure 24.5**) – a chamber of supersaturated gas that produce a condensation trail along the path of a radiation particle, and 3) bubble chambers – a chamber of superheated liquid that produces a trail of bubbles along the path of a radiation particle.

**FIGURE 24.5**

Cloud chamber shows vapor trails produced by sub-atomic particles.

Cloud chambers and bubble chambers have an additional value because the vapor trails or bubble trails left by the nuclear radiation particle are long-lasting enough to be photographed and can therefore be studied in great detail.

Particle Accelerators

In the early 1900s, the use of alpha particles for bombarding low atomic number elements became a common practice. Researchers found that the alpha particles were absorbed by the nuclei, causing a proton to be ejected. This was the first artificially caused transmutation of one element into another. In order to continue these bombardments with alpha particles or protons, the speed of the bombarding particle had to be increased. Several machines were devised to accelerate the particles to the required speeds.

The cyclotron (illustrated below) was developed by Ernest Lawrence in 1930 and used to accelerate charged particles so they would have sufficient energy to enter the nuclei of target atoms. A cyclotron consists of two hollow half

cylinders called “dees” because of their D-shapes.

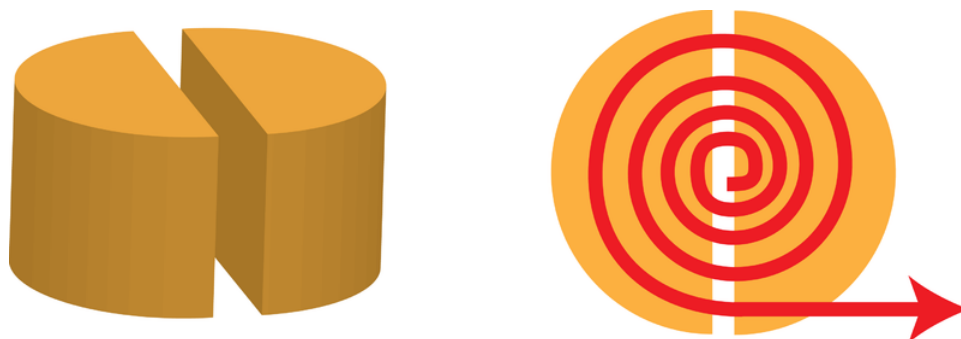

The two dees have opposite charges with a potential difference of at least 50,000 volts, and the charges on the dees can be rapidly reversed so that each dee alternately becomes positive and then negative. The cyclotron also has a powerful magnetic field passing through it so that moving charged particles will be caused to travel in a curved path. Charged particles produced from a source in the center of the area between the dees are attracted first toward one dee and then toward the other as the charge on the dees alternate. As the particle moves back and forth in the dees, it is caused to follow a curved path due to the magnetic field. The motion of the particle is that of a spiral with ever increasing speed. As the circular path of the particle nears the outside edge of the cyclotron, it is allowed to exit through a window and strikes whatever target is placed outside the window.

A different particle accelerator is the linear accelerator, which is a long series of tubes that are connected to a source of high frequency alternating voltage. As the charged particles leave each tube, the charge on the tubes are altered so the particle is repelled from the tube it is leaving and attracted to the tube it is approaching. In this way, the particle is accelerated between every pair of tubes.

A number of the elements listed in the periodic table are not found in nature. These elements include all elements with atomic numbers greater than 92, technetium (#43), and promethium (#61). The transuranium elements (those with atomic numbers greater than 92) are all man-made elements, many of which were produced in the cyclotron in the radiation laboratory at the University of California at Berkeley under the direction of Glenn Seaborg (**Figure 24.6**).



FIGURE 24.6

Glenn Seaborg.

Nuclear Medicine

The field of nuclear medicine has expanded greatly in the last twenty years. A great deal of the expansion has come in the area of imaging. Radioiodine (I-131) therapy involves the imaging and treatment of the thyroid gland. The gland uses iodine in the process of its normal function, which includes producing hormones that regulate metabolism. Any iodine in food that enters the bloodstream is usually removed by, and concentrated in the thyroid gland. In some individuals, this gland becomes overactive and produces too much of these hormones. The treatment for this problem uses radioactive iodine (I-131), which is produced for this purpose in research fission reactors or by neutron bombardment of other nuclei. When a patient suffering from an overactive thyroid swallows a small pill containing radioactive iodine, the I-131 is absorbed into the bloodstream and follows the same process to be concentrated in the thyroid. The concentrated emissions of nuclear radiation in the thyroid destroy some of the gland's cells and control the problem of the overactive thyroid.

Smaller doses of I-131 (too small to kill cells) are also used for purposes of imaging the thyroid. Once the iodine is concentrated in the thyroid, the patient lies down on a sheet of film, and the radiation from the I-131 makes a picture of the thyroid on the film. The half-life of iodine-131 is approximately 8 days, so after a few weeks, virtually all of the radioactive iodine is out of the patient's system.

Positron emission tomography (PET) scan is a type of nuclear medicine imaging. Depending on the area of the body being imaged, a radioactive isotope is either injected into a vein, swallowed by mouth, or inhaled as a gas. When the radioisotope is collected in the appropriate area of the body, the gamma ray emissions are detected by a PET scanner (often called a gamma camera), which works together with a computer to generate special pictures providing details on both the structure and function of various organs. PET scans are used to:

- detect cancer
- determine the amount of cancer spread
- assess the effectiveness of treatment plans
- determine blood flow to the heart muscle
- determine the effects of a heart attack
- evaluate brain abnormalities such as tumors and memory disorders
- map brain and heart function

External beam therapy (EBT) is a method of delivering a high energy beam of radiation to the precise location of a patient's tumor. These beams can destroy cancer cells and, with careful planning, *not* kill surrounding cells. The concept is to have several beams of radiation, each of which is sub-lethal, enter the body from different directions. The only place in the body where the beam would be lethal is at the point where all the beams intersect. Before the EBT process, the patient is mapped three-dimensionally using CT scans and X-rays. The patient receives small tattoos to allow the therapist to line up the beams exactly. Alignment lasers are used to precisely locate the target. The radiation beam is usually generated with a linear accelerator. EBT is used to treat the following diseases as well as others:

- breast cancer
- colorectal cancer
- head and neck cancer
- lung cancer
- prostate cancer

Nuclear Weapons

There are two basic types of nuclear weapons: fission bombs using supercritical masses of either U-235 or Pu-239, and fusion bombs using heavy isotopes of hydrogen. The fission bombs were called atomic bombs (a misnomer since the energy comes from the nucleus), and fusion bombs are called thermonuclear bombs. Fission bombs use two or more subcritical masses of fissile materials separated by enough distance that they don't become critical. The materials are surrounded by conventional explosives. The conventional explosives are detonated to drive the subcritical masses of fissile material toward the center of the bomb. When these masses are slammed together, they form a supercritical mass, and a nuclear explosion ensues. Hydrogen bombs (fusion) are detonated by using a small fission explosion to compress and heat a mass of deuterium or deuterium and tritium to the point that a fusion reaction ignites. An image of a nuclear explosion (as part of a nuclear test) is shown in **Figure 24.7**.



FIGURE 24.7

Castle-Romeo nuclear explosion.

Nuclear weapons are power-rated by comparison to the weight of conventional explosives (TNT) that would produce an equivalent explosion. For example, a nuclear device that produces an explosion equivalent to 1,000 tons (2,000,000 pounds) of TNT would be called a 1-kiloton bomb. The atomic bomb detonated at Hiroshima near the end of WWII was a 13-kiloton bomb that used 130 pounds of U-235. It has been estimated that this weapon was very inefficient and that less than 1.5% of the fissile material actually fissioned. The atomic bomb detonated at Nagasaki was a 21-kiloton weapon that used 14 pounds of Pu-239. The two bombs set off in Japan would be considered very small bombs by later standards. Bombs that were tested later were measured not by kilotons but by megatons (million tons) of TNT. The largest bomb ever set off was a 50-megaton fusion weapon tested by the Soviet Union in

the 1950s.

The extensive death and destruction caused by these weapons comes from four sources. The tremendous heat released by the explosion heats the air so much and so quickly that the air expansion creates a wind in excess of 200 miles/hour – many times stronger than the strongest hurricane. The blast force from this wind completely destroys all but the strongest buildings for several miles from ground zero. The second source of damage is from fires ignited by the heat from the fireball at the center of the explosion. The fireball in the 50-megaton test was estimated to be four miles in diameter. The third source of injury is the intense nuclear radiation (primarily gamma rays), which are instantly lethal to exposed people for several miles. The final source of injury and possibly death comes from the radioactive fall-out, which may be several tons of radioactive debris and may fall up to 300 miles or more away. This fall-out can cause sickness and death for many years.

Lesson Summary

- The fission of U-235 or Pu-239 is used in nuclear reactors.
- The critical mass is the amount of fissile material that will maintain a chain reaction.
- Nuclear radiation also has many medical uses.

Further Reading / Supplementary Links

For more details about nuclear power versus other sources of power, you can read the following report.

- *Nuclear Power VS. Other Sources of Power*; Neil M. Cabreza, Department of Nuclear Engineering, University of California, Berkeley, NE-161 Report.

The following web site contains a history of the discovery (creation) of the transuranium elements and includes some of the reactions used to produce them.

- <http://www.lbl.gov/abc/wallchart/chapters/08/0.html>

Review Questions

1. What is the primary physical difference between a nuclear electricity generating plant and a coal-burning electricity generating plant?
2. What do the control rods in a nuclear reactor do and how do they do it?
3. What is a breeder reactor?
4. Name two types of particle accelerators.
5. In the medical use of radioactivity, what does EBT stand for?
6. Is it possible for a nuclear explosion to occur in a nuclear reactor? Why or why not?

All images, unless otherwise stated, are created by the CK-12 Foundation and are under the Creative Commons license CC-BY-NC-SA.

24.8 References

1. . [Marie Sklodowska Curie before she moved to Paris](#). Public domain
2. Richard Parsons. Graph of binding energy per nucleon. CC-BY-NC-SA
3. NASA Goddard Laboratory for Atmospheres. [Sun as viewed by the Soft X-Ray Telescope](#). Public domain
4. Theresa Knott. [A Geiger Counter](#). GNU Free Documentation
5. NASA, modified by Richard Parsons. [Cloud chamber](#). Public domain
6. . [Glenn Seaborg](#). Public Domain
7. United States Department of Energy. [Castle-Romeo nuclear explosion](#). Public domain

CHAPTER 25**Organic Chemistry****Chapter Outline**

- 25.1 CARBON, A UNIQUE ELEMENT**
 - 25.2 HYDROCARBONS**
 - 25.3 AROMATICS**
 - 25.4 FUNCTIONAL GROUPS**
 - 25.5 BIOCHEMICAL MOLECULES**
 - 25.6 REFERENCES**
-

25.1 Carbon, A Unique Element

Lesson Objectives

The student will:

- describe the hybridization states available to carbon.
- explain how the hybridization of carbon allows for the formation of large number of compounds containing carbon.
- describe the three primary allotropes of carbon.

Vocabulary

- allotropes
- delocalized electrons

Introduction

Carbon plays a unique role among the chemical elements. You may have heard of life on earth being referred to as “carbon-based.” Although the molecules that make up living creatures also contain large amounts of hydrogen, oxygen, nitrogen, phosphorus, and sulfur, these atoms are all generally stitched together by long carbon chains. Due to its four valence electrons, carbon is the smallest element that is able to make covalent bonds to four different atoms in its neutral form. Because of this, large, heavily branched compounds can be made by stringing together carbon and a few other nonmetallic atoms in various arrangements. The almost limitless number of compounds that can be constructed in this way is the focus of organic chemistry.

Hybridization

Recall from the chapter “Covalent Bonds and Formulas” that s and p atomic orbitals can be combined in various ratios to make a set of hybrid orbitals. During hybridization, the number of orbitals combined to make the hybrids is always equal to the number of orbitals created. Thus, carbon will always have a total of four valence orbitals, regardless of how it is hybridized.

When one s and three p orbitals are combined, it produces a set of four sp^3 orbitals (see figure below). These orbitals are all identical to one another, and they point outward from the carbon atom toward the corners of a tetrahedron. Recall from VSEPR theory that when a central atom is bonded to four different atoms, they are arranged into the shape of a tetrahedron. The shapes of the hybrid orbitals used to make these bonds help explain why this arrangement is chosen.

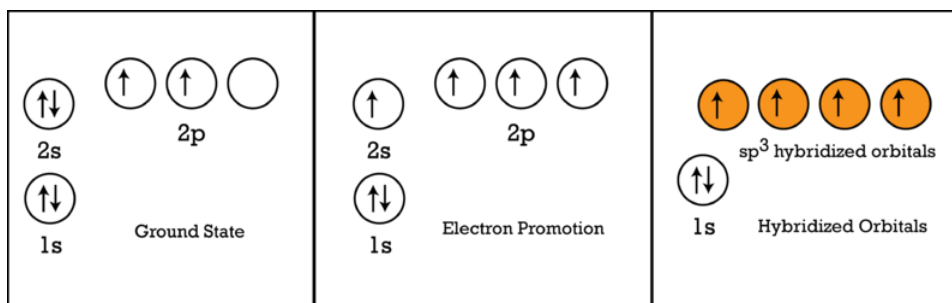

When one *s* and two *p* orbitals are combined, a set of three identical *sp*² orbitals is created (see below). These orbitals have a trigonal planar arrangement, which is what we would expect from VSEPR theory for a central atom bonded to three other atoms, assuming it has no unshared electron pairs. In addition to the three hybrid orbitals created, the carbon atom will still have one leftover *p* orbital oriented perpendicular to the other three. This orbital is available for side-by-side overlap with other *p* orbitals, forming a pi bond.

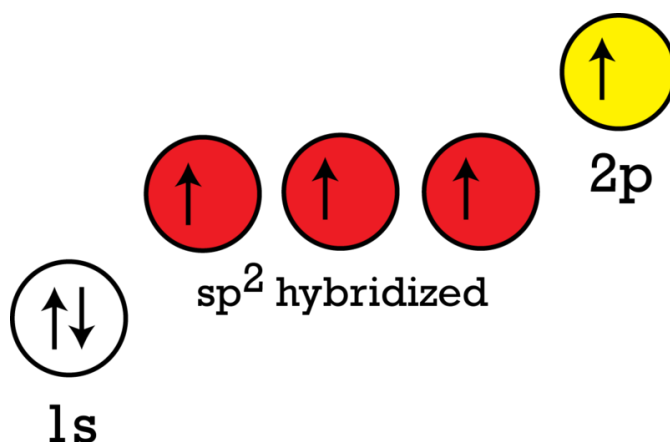

Lastly, *sp* orbitals are created by combining one *s* and one *p* orbital, leaving two unchanged *p* orbitals available for pi bonding. The two *sp* orbitals point in opposite directions, which is again what one would expect by looking at VSEPR theory. The number of different hybridization states available to carbon further amplifies the number of organic (carbon-containing) compounds that can be made.

Allotropes of Carbon

Carbon can exist in at least three different forms based on the arrangement of bonds between the atoms. Although these substances are comprised only of carbon atoms, they have quite different properties. When a pure element exists in multiple forms due to different bonding arrangements, these forms are referred to as **allotropes**. Note that different phases (solid, liquid, gas) of an element are not considered to be allotropes; a family of allotropes must all be in the same phase. The three primary allotropes of carbon are diamond, graphite, and fullerenes.

The structure of diamond consists exclusively of *sp*³ hybridized carbon atoms. Each one is bound to four other carbon atoms in a tetrahedral array (see **Figure 25.1**). This is a very stable structure, because each atom is held in place by four strong sigma bonds. Consequently, diamonds are extremely hard, and the diamond form of carbon has the highest melting point (>3500°C) of all known elements. Diamond has the rare property that it is a good conductor of heat but a poor conductor of electricity. Electricity is transmitted by the movement of electrons, and since all the valence electrons of diamond are held tightly in localized sigma bonds, very little electric current can flow through the solid.

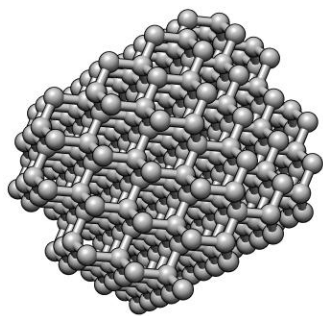

FIGURE 25.1

Diamond lattice structure.

Graphite, most commonly encountered as pencil lead, is clearly a very different substance. The reason for the differing properties has to do with how the atoms are bonded to one another. The structure of graphite is shown in [Figure 25.2](#).

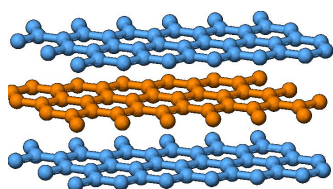

FIGURE 25.2

Graphite structure with multiple layers.

The carbon atoms are sp^2 hybridized, and each carbon makes a strong sigma bond to three other atoms, forming hexagonal sheets. However, this only accounts for three of carbon's four valence electrons. The remaining electron is located in the leftover p orbital. This orbital can overlap with the leftover p orbital from all the adjacent carbon atoms, forming pi bonds. Unlike sigma bonds, where the electrons are held tightly between the two nuclei, pi bonds can interact with adjacent pi bonds, allowing the electrons in those bonds to **delocalize** over all the atoms involved.

Within a sheet of graphite, the carbon atoms are held together by strong sigma bonds. The bond between sheets, however, involves a weaker interaction between the delocalized pi systems of two adjacent sheets. Because of the delocalization, a carbon from one sheet is not rigidly attached to any single carbon from an adjacent sheet, which allows the sheets to slide around freely. For this reason, graphite can be used as a lubricant. When you write with a pencil, the marks left on the paper are sheets of graphite that have slipped all the way off the carbon rod.

Unlike diamond and graphite, which are covalent networks that can extend indefinitely, fullerenes often have a fixed size, forming what are essentially individual molecules made only of carbon. The first fullerene to be discovered was buckminsterfullerene, C_{60} , often referred to as a buckyball (see [Figure 25.3](#)).

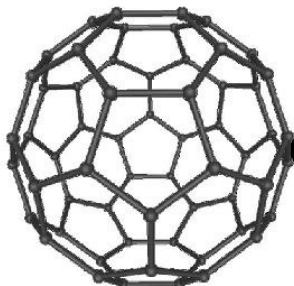

FIGURE 25.3

Buckyball structure (left) compared to soccer ball (right).

This allotrope of carbon was not even isolated until 1985, although its possible existence had been postulated in the mid-20th century. A great deal of current research in medicinal chemistry and material science is devoted to the study of this relatively new class of compounds. Examples include carbon nanotubes (fullerenes that fold into a tube instead of a sphere) and superconducting metal-fullerene complexes.

Lesson Summary

- Hybridization is the process of combining atomic orbitals from different subshells to create a new set of orbitals that are all identical to one another. The electrons in these orbitals have equal energy and can all form identical covalent bonds.
- Electrons located in p orbitals that are not used during hybridization are available for side-by-side (π) bonding.
- Allotropes are the different forms that can be taken by a pure element. Each allotrope is a unique substance with its own chemical properties.
- The differences between allotropes stem from the different bonding arrangements available to those atoms.
- The three primary allotropes of carbon are diamond, graphite, and fullerenes.

Further Reading / Supplemental Links

The *learner.org* website allows users to view streaming videos of the Annenberg series of chemistry videos. You are required to register before you can watch the videos but there is no charge. The website has one video that relates to this lesson called “Carbon.”

- <http://learner.org/resources/series61.html>

Review Questions

1. Carbon is considered to be unique in the periodic table. What property of the carbon atom makes it unique?
2. What is the difference between sp , sp^2 , and sp^3 hybridization?
3. Which of the following are allotropes of carbon?
 - a. diamond
 - b. buckminsterfullerene
 - c. graphite
 - d. all of the above
4. What is the hybridization of the carbon atoms in each of the following molecules:

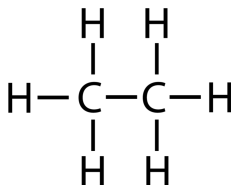

- a. sp
- b. sp^2
- c. sp^3
- d. dsp^3

25.2 Hydrocarbons

Lesson Objectives

The student will:

- define structural isomers and be able to draw isomers for selected compounds
- differentiate between alkanes, alkenes, and alkynes
- name alkanes, alkenes, and alkynes when given a structure
- draw alkanes, alkenes, and alkynes when given a name
- explain the difference between saturated and unsaturated hydrocarbons

Vocabulary

- alkane
- alkene
- alkyne
- functional group
- saturated compound
- structural isomers
- unsaturated compound

Introduction

The basic skeleton of any organic molecule consists primarily of carbon and hydrogen atoms bounded to one another in various arrangements. In this section, we will explore various types of organic compounds that include only carbon and hydrogen. In a later section, we will consider the additional possibilities that exist when other atoms are bound to a hydrocarbon backbone.

Alkanes

Alkanes are the simplest hydrocarbons. All carbon atoms are sp^3 hybridized, and each carbon atom makes four sigma bonds. Depending on the size of the chain, alkanes can exist as solids, liquids, or gases at room temperature. Alkanes are non-polar molecules, so they are not soluble in water.

At low temperatures, alkanes are generally not very reactive compared to most other organic molecules. However, when provided with an initial source of energy, alkanes can react with oxygen (a combustion reaction) to produce carbon dioxide and water. Because of this property, many alkanes are used as fuels, including methane (natural gas),

propane (used in gas grills), butane (found in lighters), and octane (found in gasoline). Larger alkanes exist as waxy solids. Since they burn less quickly than their smaller counterparts, they are used to make candles.

Naming Alkanes

Due to the immense variety of possible organic structures that can exist, it is necessary to have a systematic method for naming these compounds so that chemists can communicate with one another. There are a set of fairly straightforward rules that will allow you to name most of the organic compounds you will encounter.

The basic starting point for learning about organic nomenclature is to look at the straight-chain alkanes. The first ten are compiled in **Table 25.1**. Note that although the structures are drawn in a linear format, the shape around each carbon atom is still tetrahedral. Thus, the actual three-dimensional structure of these compounds would look more like a zig-zag.

TABLE 25.1: First Ten Alkanes

Name	Formula	Structural Formula
methane	CH ₄	$\begin{array}{c} \text{H} \\ \\ \text{H}-\text{C}-\text{H} \\ \\ \text{H} \end{array}$
ethane	C ₂ H ₆	$\begin{array}{c} \text{H} \quad \text{H} \\ \quad \\ \text{H}-\text{C}-\text{C}-\text{H} \\ \quad \\ \text{H} \quad \text{H} \end{array}$
propane	C ₃ H ₈	$\begin{array}{c} \text{H} \quad \text{H} \quad \text{H} \\ \quad \quad \\ \text{H}-\text{C}-\text{C}-\text{C}-\text{H} \\ \quad \quad \\ \text{H} \quad \text{H} \quad \text{H} \end{array}$
butane	C ₄ H ₁₀	$\begin{array}{c} \text{H} \quad \text{H} \quad \text{H} \quad \text{H} \\ \quad \quad \quad \\ \text{H}-\text{C}-\text{C}-\text{C}-\text{C}-\text{H} \\ \quad \quad \quad \\ \text{H} \quad \text{H} \quad \text{H} \quad \text{H} \end{array}$
pentane	C ₅ H ₁₂	$\begin{array}{c} \text{H} \quad \text{H} \quad \text{H} \quad \text{H} \quad \text{H} \\ \quad \quad \quad \quad \\ \text{H}-\text{C}-\text{C}-\text{C}-\text{C}-\text{C}-\text{H} \\ \quad \quad \quad \quad \\ \text{H} \quad \text{H} \quad \text{H} \quad \text{H} \quad \text{H} \end{array}$
hexane	C ₆ H ₁₄	$\begin{array}{c} \text{H} \quad \text{H} \quad \text{H} \quad \text{H} \quad \text{H} \quad \text{H} \\ \quad \quad \quad \quad \quad \\ \text{H}-\text{C}-\text{C}-\text{C}-\text{C}-\text{C}-\text{C}-\text{H} \\ \quad \quad \quad \quad \quad \\ \text{H} \quad \text{H} \quad \text{H} \quad \text{H} \quad \text{H} \quad \text{H} \end{array}$

TABLE 25.1: (continued)

Name	Formula	Structural Formula
heptane	C_7H_{16}	$ \begin{array}{ccccccc} & H & H & H & H & H & H \\ & & & & & & \\ H & - C & - C & - C & - C & - C & - C - H \\ & & & & & & \\ & H & H & H & H & H & H \end{array} $
octane	C_8H_{18}	$ \begin{array}{cccccccc} & H & H & H & H & H & H & H \\ & & & & & & & \\ H & - C & - C & - C & - C & - C & - C & - C - H \\ & & & & & & & \\ & H & H & H & H & H & H & H \end{array} $
nonane	C_9H_{20}	$ \begin{array}{ccccccccc} & H & H & H & H & H & H & H & H \\ & & & & & & & & \\ H & - C & - C & - C & - C & - C & - C & - C & - C - H \\ & & & & & & & & \\ & H & H & H & H & H & H & H & H \end{array} $
decane	$C_{10}H_{22}$	$ \begin{array}{cccccccccc} & H & H & H & H & H & H & H & H & H \\ & & & & & & & & & \\ H & - C & - C & - C & - C & - C & - C & - C & - C & - C - H \\ & & & & & & & & & \\ & H & H & H & H & H & H & H & H & H \end{array} $

The names of these simple compounds consist of two parts. As you may be able to deduce from the examples, the suffix “-ane” indicates that these compounds are alkanes. The first part of the name indicates how many carbon atoms are in the chain. The prefixes associated with each number are shown in **Table 25.2**. These should be committed to memory.

TABLE 25.2: Numerical Prefixes for Straight Chain Organic Compounds

Number of C atoms in the longest chain	Numerical Prefix
1	meth-
2	eth-
3	prop-
4	but-
5	pent-
6	hex-
7	hept-
8	oct-
9	non-
10	dec-

Example:

Name the following molecule:

**Solution:**

This is a straight chain hydrocarbon with all single bonds. Therefore, it is an alkane. Since the longest straight chain contains 5 carbon atoms, it is pentane.

You should recognize that the actual molecule does not look like this straight chain picture. The bonding around every carbon atom is a tetrahedron. Therefore, these molecules look more like saw teeth than they do straight chains.

They are drawn in straight lines to make it easier to draw them. If the same molecule is drawn with a bend in it, it is still a straight chain (see below).

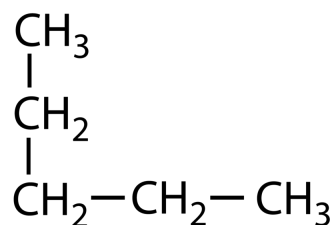

This molecule is still a 5-carbon straight chain and is still pentane.

Various side chains of carbon atoms can be attached to the straight chain. When a hydrocarbon side chain is attached to the straight chain, the side chain is named according to the following **Table 25.3**.

TABLE 25.3: Alkyl Groups Branches

Alkyl Groups	Group Name
–CH ₃	methyl
–CH ₂ CH ₃	ethyl
–CH ₂ CH ₂ CH ₃	propyl
–CH ₂ CH ₂ CH ₂ CH ₃	butyl
–CH ₂ CH ₂ CH ₂ CH ₂ CH ₃	pentyl

A side chain can be attached to any carbon but the end carbons in a straight chain. If the chain were attached to an end carbon, it would be part of the straight chain. Here is a straight chain hydrocarbon with a methyl side chain attached.

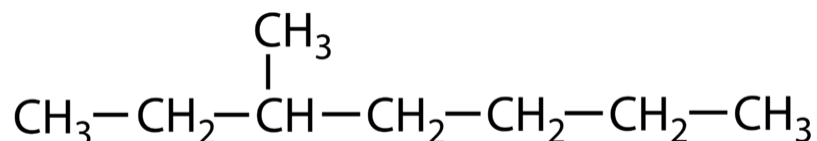

When naming this compound, we must first identify both the parent chain and the side chain. The parent chain is the longest straight chain of carbon atoms. Be careful, because this chain is not always drawn in a straight line. Additionally, we must indicate the carbon atom to which the side chain is attached. In order to identify the carbon atom to which the side chain is attached, we number the carbon atoms in the parent straight chain. Since it is possible to begin numbering at either end of the straight chain, there is a rule about how the carbon atoms are numbered. The rule is that you must number the carbon atoms in the straight chain so that the side chain is attached to the *lowest* possible numbered carbon atom. Here is the compound again with two possible numbering sequences. In the numbering on the left, the side chain is attached to carbon number 3, whereas on the right, the side chain is attached to carbon number 5. Therefore, the numbering sequence on the right is *wrong*.

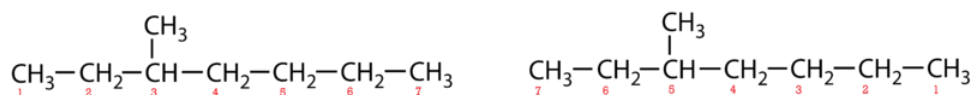

To name this compound, we indicate the number of the carbon atom to which the side chain is attached, insert a hyphen after the number (no spaces in between), then name the side chain (again no spaces), and finally name the parent straight chain (again no spaces). Therefore, the correct name of this compound is 3-methylheptane.

If two or more of the same type of side chain is present, this is indicated with a slightly different set of numerical prefixes. “Mono-” is not used because the prefix is omitted when only one of that particular side chain is present. “Eth-,” “prop-,” and “but-” are replaced with “di-,” “tri-,” and “tetra-,” respectively. The remaining prefixes are the same as those shown above in **Table 25.3**.

If multiple different types of side chains are present, they are written in alphabetical order. When alphabetizing names, we ignore the secondary prefix that indicates how many of each side chain there are. Therefore, “ethyl” comes before “dimethyl.”

Example:

Name the following molecule:

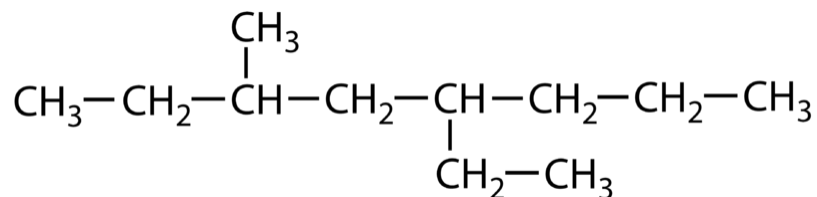

Step 1: Find the parent chain.

The longest chain in this molecules contains 8 carbon atoms. Therefore, the parent chain is octane.

Step 2: Name the branches and determine the carbon numbers to which they are attached. Looking at the molecule, there are two branches that are not part of the parent chain. Using **Table 25.3**, these branches can be identified as a methyl group and an ethyl group.

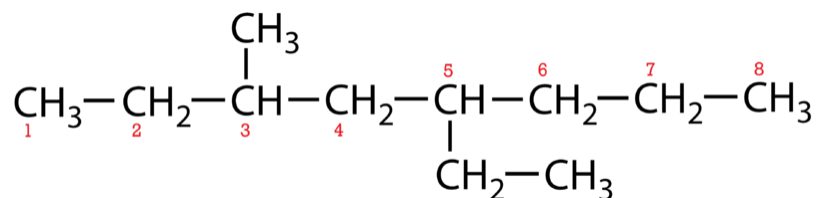

Step 3: Add the name of the branches and their positions to the parent chain name.

5-ethyl-3-methyloctane

Notice that there are no spaces anywhere in the name.

Drawing Alkanes

So far, we have been given the structure of the molecule and asked to provide a name. However, there are also cases where we will be given a name and asked to draw the structure. Converting names to structures is generally easier than converting structures to names.

Example:

Draw the structure for butane, C₄H₁₀.

Solution:

Step 1: Start by drawing the four carbon atoms in a straight chain with all the atoms connected by single bonds.

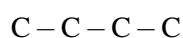

Step 2: Add single bonds until each carbon atom has four possible bonding sites.

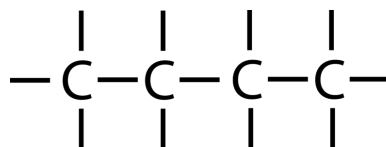

Step 3: Add one hydrogen atom to the end of each of the single bonds formed in Step 2.

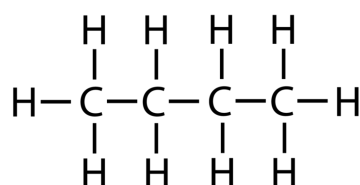

Prior to this chapter, we have mainly been considering compounds that can be uniquely identified simply by writing their chemical formula. However, this is not the case for organic molecules. In the previous example, you were asked to draw the structure for butane, C_4H_{10} . However, this is not the only way that those atoms could be arranged. Drawn below is 2-methylpropane. It is still composed of four carbon atoms and ten hydrogen atoms, but they are arranged in a different way. Two molecules that have the same formula but different bonding arrangements are referred to as **structural isomers**.

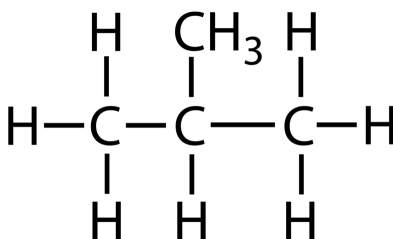

Structural isomers have the same formula, but because they have different structures, they also have different chemical properties. As the number of carbon atoms increases, the number of possible isomers increases. For example, decane has 75 structural isomers, each with its own properties. A compound such as $C_{30}H_{62}$ has 4×10^8 isomers, many of which have not even been isolated yet. With this many possible compounds, you can understand the need for this complex naming system.

Example:

Draw the structural isomers of pentane, C_5H_{12} .

Solution:

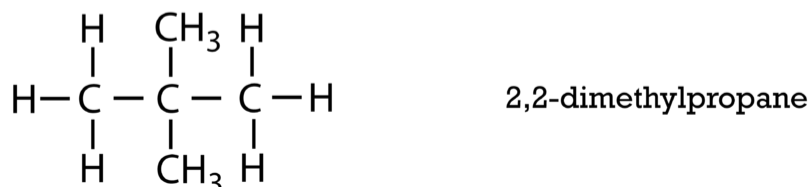
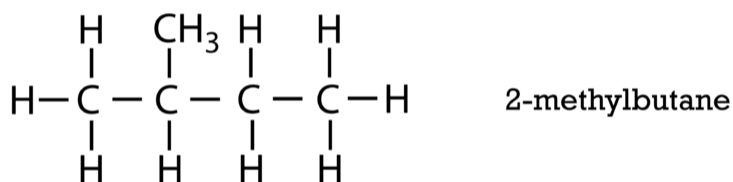
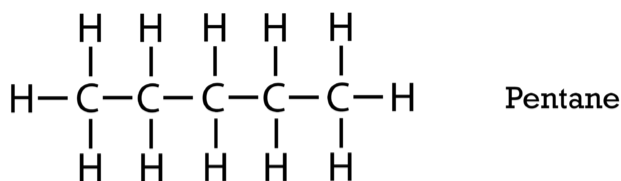

Alkenes

Alkanes provide the basic skeleton for organic molecules. Although there are vast numbers of alkanes that could potentially be constructed, the chemistry available to alkanes is quite similar and is relatively limited. Generally, the reactivity of an organic molecule is determined by its functional groups. **Functional groups** include double bonds, triple bonds, and groups that contain atoms other than carbon and hydrogen. The first functional group we will consider is an **alkene**, which is defined as a double bond between two carbon atoms.

When a molecule has only one functional group, sometimes the name of the functional group is used to refer to the entire molecule. For example, the entire 2-hexene molecule can be referred to as an alkene, even though the only double bond is between carbons 2 and 3.

Because the carbons in an alkene are not surrounded by the maximum number of other atoms, alkenes are referred to as **unsaturated**. Conversely, alkanes are referred to as **saturated**, since no additional atoms can be added to any of the carbons without removing some of the ones already present.

As we stated earlier, simple alkanes are generally not very reactive unless enough energy is added to start a combustion reaction. This can be explained by the fact that alkanes contain only C-C and C-H sigma bonds, both of which are relatively strong. In contrast, alkenes contain pi bonds, which are not as strong. Much of the chemistry of alkenes involves breaking this relatively weak bond to create two new sigma bonds between the carbons of the alkene and atoms from other molecules.

Naming Alkenes

The naming of alkenes is very similar to that for alkanes, except for a few key differences:

1. The end of the name is changed from “-ane” to “-ene.”
2. The parent chain should always include the double bond, even if it is no longer the longest chain of carbon atoms.
3. Numbering begins at the end of the parent chain closest to the double bond
4. The position of the double bond is indicated by inserting the number of the carbon closest to the end just before the name of the parent chain.

Example:

Name the following compound.

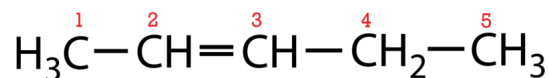
**Solution:**

The parent chain has five (5) carbon atoms. Using **Table 25.2**, the prefix for this compound is “pent-.”

There are no branches, but the double bond is between carbons 2 and 3. Therefore the name of the molecule is 2-pentene (using the smaller of the two numbers on the carbon atoms).

Drawing Alkenes

Drawing alkenes also follows the same rules as drawing alkanes. Remember to place the double bond where the name indicates its placement.

Example:

Draw the structural formula for 4-methyl-2-heptene.

Solution:

Looking at the name reveals a great deal about how to draw the structure.

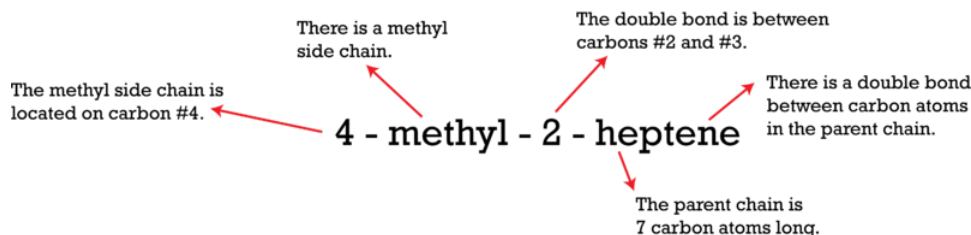

Therefore, the molecule has the structure:

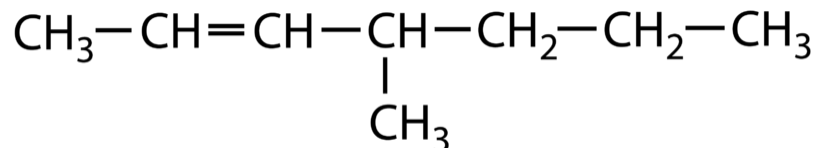

When numbering alkene chains, you always begin with the carbon end nearest to the double bond regardless of what this does to the side chain number.

Alkynes

An **alkyne** is a carbon-carbon triple bond. It can also refer to a molecule containing a carbon-carbon triple bond. Like alkenes, alkynes are considered unsaturated because the carbons in the triple bond are not surrounded by the maximum number of other atoms.

Naming Alkynes

Alkynes are named in the same way as alkenes, except the suffix at the end of the parent chain is changed to “-yne.” For these compounds, the position of the triple bond is indicated in the name of the structure.

Example:

Name the following structure.

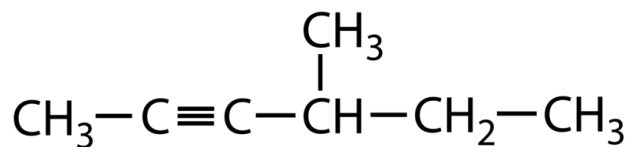

Solution:

The parent chain has six carbon atoms. Using **Table 25.2**, the prefix is “hex-.”

There is a triple bond, so the suffix is “-yne.”

The triple bond is between carbons 2 and 3.

There is one branch on carbon 4 that is a methyl group.

Therefore the name of the molecule is 4-methyl-2-hexyne.

Drawing Alkynes

To draw alkynes, again follow the same rules as for alkanes and alkenes. Remember to place the triple bond where the name indicates its placement.

Example:

Draw the structural formula for 5-ethyl-3-octyne.

Solution:

Looking at the name reveals a great deal about how to draw the structure.

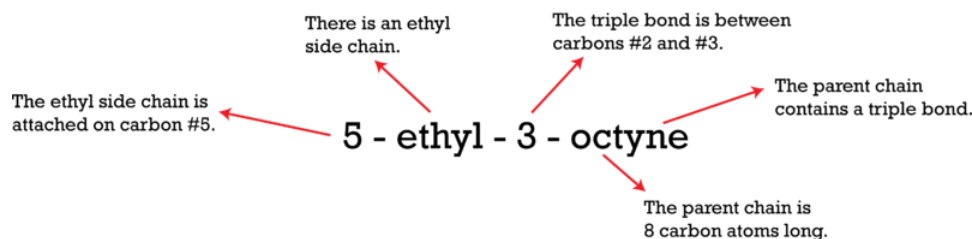

Therefore, the molecule has the structure:

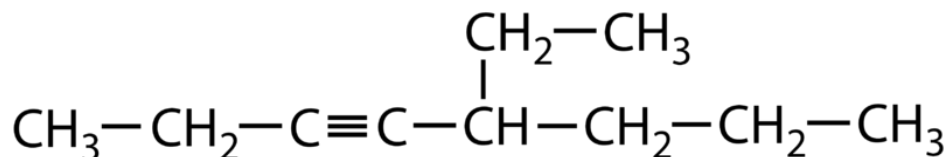

This video is an introduction to process of naming hydrocarbons (**10d**), see http://www.youtube.com/watch?v=c_mzHMHw6oeA (9:02).

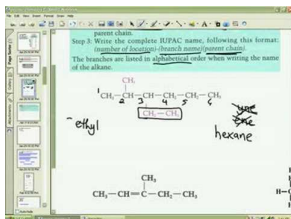

MEDIA

Click image to the left for more content.

Lesson Summary

- Alkanes are relatively unreactive hydrocarbons that contain only C-C and C-H single bonds.
- Alkenes contain a carbon-carbon double bond.
- Alkynes contain a carbon-carbon triple bond.
- Organic molecules containing only single bonds are referred to as saturated, while those containing double or triple bonds are referred to as unsaturated.

Further Reading / Supplemental Links

The *learner.org* website allows users to view the Annenberg series of chemistry videos. You are required to register before you can watch the videos, but there is no charge to register. The video called “Molecular Architecture” examines isomers (primarily organic molecules) and how the electronic structure of a molecule’s elements and bonds affects its shape and physical properties.

- http://www.learner.org/vod/vod_window.html?pid=801

Review Questions

1. Define the terms alkane, alkene and alkyne.
2. What is the difference between a saturated and an unsaturated compound?
3. Which of the following organic compounds is unsaturated?
 - a. ethylcyclobutane
 - b. 3-ethyl-2-methyl-1-pentene
 - c. 2-bromobutane
 - d. 2-methyl-1-chlorohexane
4. Which compound is a structural isomer of the compound shown below?

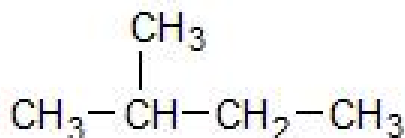

- a. butane
- b. methane
- c. pentane
- d. hexane

5. Which structures are isomers of one of the other structures?

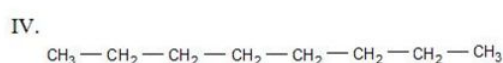
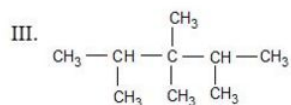
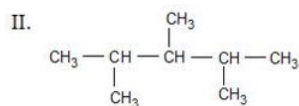
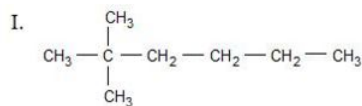

- I, II, III
- II, III
- I, II, IV
- They are all isomers.

6. Which of the following structures has the shortest parent chain? (There can be more than one correct answers.)

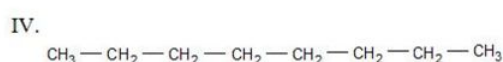
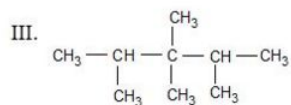
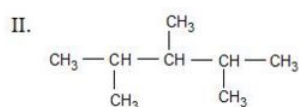
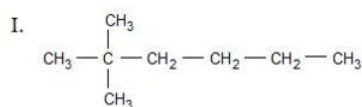

7. Draw each of the following compounds.

- 2,3,4-trimethylpentane
- 2-chloro-1-propene
- 1-bromo-2-methylbutane
- Ethyne
- 1-bromo-5,5-dimethylheptane

8. Name each of the following structures.

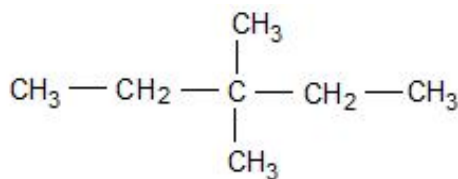

a.

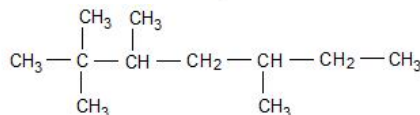

b.

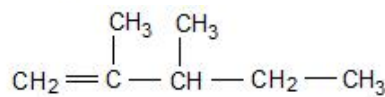

c.

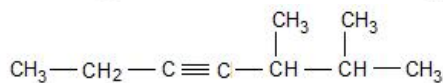

d.

9. Name the isomers for C_6H_{14} .

25.3 Aromatics

Lesson Objectives

The student will:

- describe the bonding in benzene.
- define aromatic compounds.
- name simple compounds containing benzene.
- draw simple compounds containing benzene.

Vocabulary

- benzene ring

Introduction

In this lesson, we will focus on another category of organic compounds called the aromatics. One common building block of aromatic compounds is benzene. Benzene is composed of a 6-membered carbon ring commonly represented by the resonance structures below.

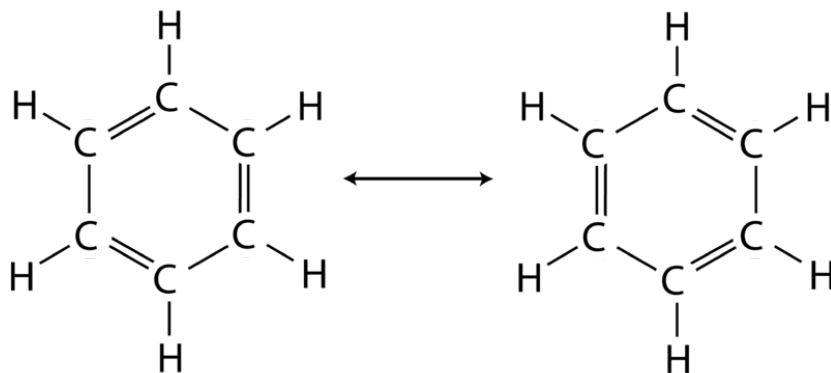

Benzene was discovered in the 1820s by Michael Faraday, but it took more than 40 years to determine the actual structure of benzene. The German organic chemist Friedrich August Kekulé is credited for discovering the benzene structure in 1865. Legend has it that Kekulé discovered the benzene structure upon awaking from a dream of a snake biting the end of its tail.

A compound classified as an aromatic doesn't necessarily have to have a pleasant smell, although many aromatic compounds do have a pleasant odor. Vanilla (structure shown below) is an example of a pleasant-smelling aromatic compound. In comparison, naphthalene (structure shown below) is the chemical found in moth balls with an unpleasant smell. In short, aromaticity has to do with structure and not smell.

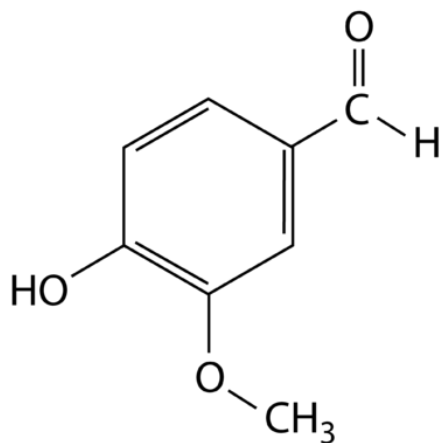

Vanilla

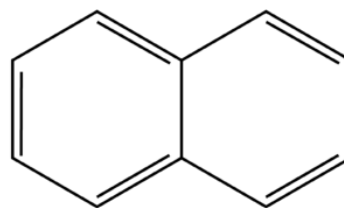

Naphthalene

Benzene Structure

As indicated in the introduction, there are two possible structures of the benzene molecule (C_6H_6).

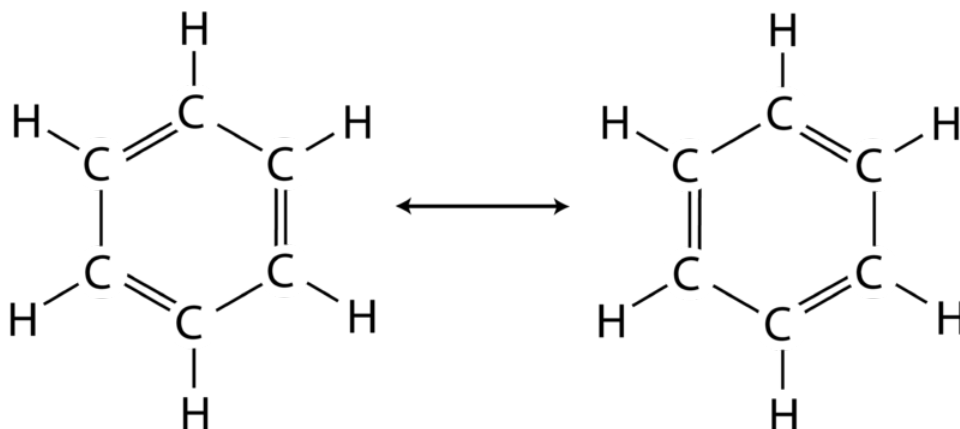

Both of these structures represent resonance structures of the benzene molecule. Recall from the chapter “Covalent Bonds and Formulas” that resonance is the theory that describes compounds whose electronic structure is not represented by any one Lewis structure, but by an average of several structures. This theory, proposed by American chemist Linus Pauling, can be used to explain the structure of benzene. Although the structure shows alternating double and single bonds, all of the bonds are actually the same length. Carbon-carbon single bonds are 154 pm long, while carbon-carbon double bonds are 134 pm in length. For benzene, however, all of the carbon-carbon bonds in benzene are 139 pm in length, so they are neither single nor double bonds. As a result, you may sometimes see a benzene structure represented as follows:

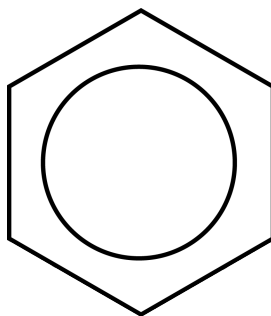

A **benzene ring**, then, is a structure that contains a ring represented by equivalent resonance structures. Benzene is an important compound in organic chemistry because of its properties and the vast number of compounds in which a benzene ring is an integral part of the structure.

Benzene is a part of many everyday items. Examples of structures where the benzene ring is an integral part of the structure include aspirin, saccharin, and aspartame (structures shown below). Aspirin is a common painkiller, while both saccharin and aspartame are artificial sweeteners. Aspartame is commonly used in soft drinks and diet drinks.

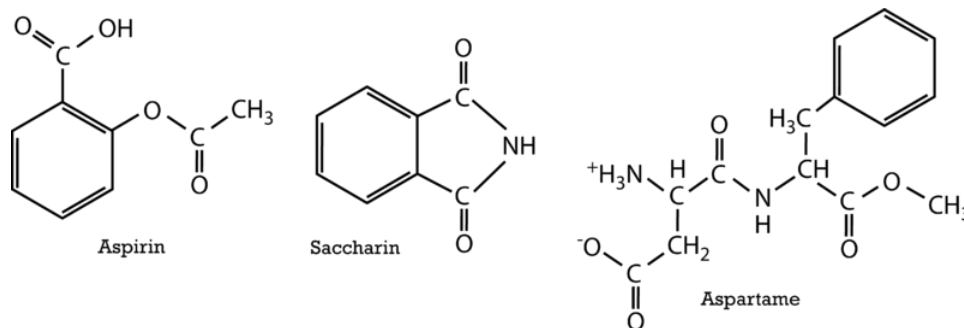

Naming Benzene Structures

All of the carbon atoms in the benzene ring have one hydrogen atom attached. If we were to replace one of these hydrogens with a branch from **Table 25.4**, the naming is simply the name of the branch plus “benzene.”

TABLE 25.4: Branches

Group	Name
-CH ₃	methyl-
-CH ₂ CH ₃	ethyl-
-F	fluoro-
-Cl	chloro-
-Br	bromo-
-I	iodo-
-NO ₂	nitro-

Example:

Name the following structure.

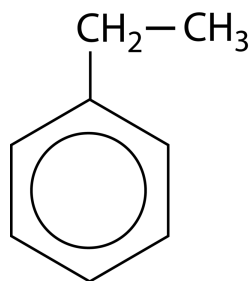

Solution: ethylbenzene

When there is more than one substituent on the benzene ring, then there has to be a way to determine the position of each branch. We number the carbon atoms the same as we had done for the alkanes, alkenes, and alkynes.

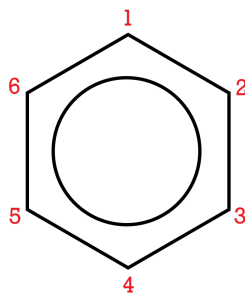

By numbering, we have a way to methodically determine the location of each branch on the benzene ring.

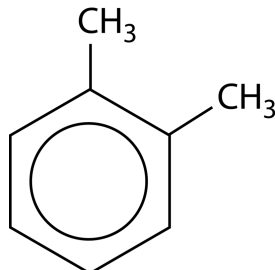

- The branches are both methyl groups
- The locations of the methyl groups are on carbons 1 and 2.
- The name of the molecule is 1,2-dimethylbenzene.

An alternate naming system is given for molecules with two substituent groups (two branches). Alternate names are provided in **Table 25.5**.

TABLE 25.5: Alternate Naming System for Disubstituted Benzene

Location of branches	Prefix	Prefix symbol
carbons 1 and 2	ortho-	<i>o</i> -
carbons 1 and 3	meta-	<i>m</i> -
carbons 1 and 4	para-	<i>p</i> -

The prefix “ortho-” indicates that the two substituents are on adjacent carbon atoms. The prefix “meta-” indicates that the two substituents are on carbon atoms with one carbon atom between them. The prefix “para-” indicates

that the two substituents are on opposite carbon atoms. Therefore, 1,2-dimethylbenzene could also be named ortho-dimethylbenzene, 1,3-dimethylbenzene could also be named meta-dimethylbenzene, and 1,4-dimethylbenzene could also be named para-dimethylbenzene

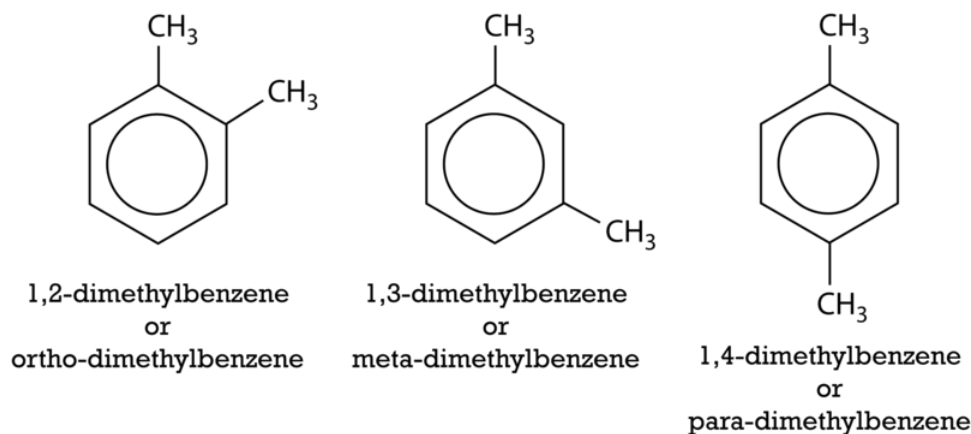
**Example:**

Name the following structure.

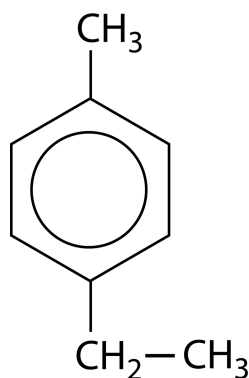
**Solution:**

- The branches are one methyl group and one ethyl group
- The locations of the methyl groups are on carbons 1 and 4.
- The name of the molecule is 1-ethyl-4-methylbenzene or, according to [Table 25.5](#), *p*-ethylmethylbenzene.

You may have noticed that in [Table 25.4](#), the number of alkyl groups acting as branches is more limited for benzene than for alkanes, alkenes, and alkynes. When the alkyl group becomes larger, the benzene ring is sometimes considered the branch, and the alkyl group is considered the parent chain. As a branch, benzene is known as a phenyl group.

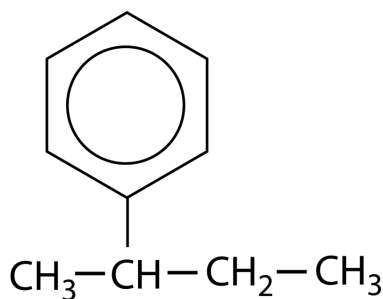

In this case, butane is the parent chain, and the benzene ring is a side chain. This molecule would be named 2-phenylbutane.

Drawing Benzene Structures

Drawing benzene structures works in a similar way as drawing alkanes, alkenes, and alkynes. Consider the following example.

Example:

Draw the structure of *p*-dinitrobenzene.

Solution:

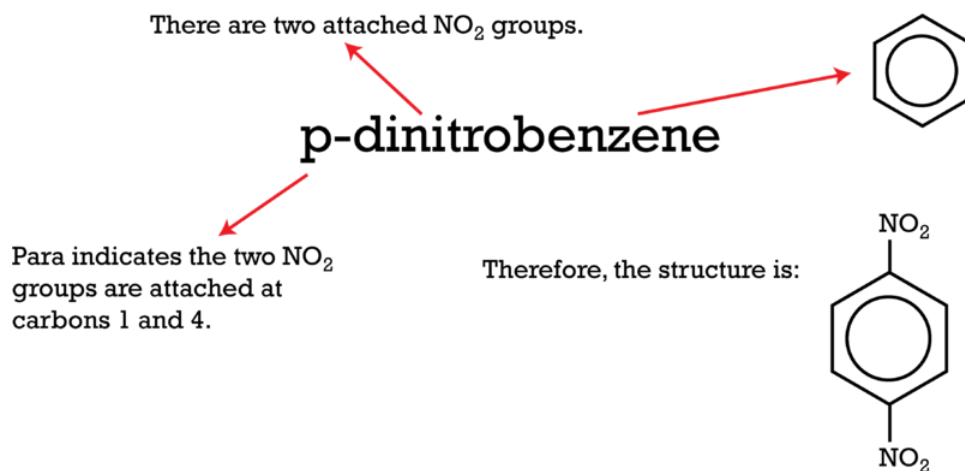

Lesson Summary

- A benzene ring is an organic structure that contains a 6-carbon ring with alternating double bonds.
- Resonance refers to a condition occurring when more than one Lewis structure can be written for a particular molecule. The actual electronic structure is not represented by any one of the Lewis structures, but by the average of all of them.
- The electrons in the pi bonds of the benzene molecule are delocalized because they are not confined to a particular pair of carbon atoms.
- As a substituent of a hydrocarbon chain, benzene is known as a phenyl group.

Further Reading / Supplemental Links

- *Chemistry and Chemical Reactivity*, Kotz, Truchel, Weaver; Thompson, 2006.

Review Questions

1. Define aromaticity.

- When is the benzene ring referred to as a phenyl group?
- Name the following structure.

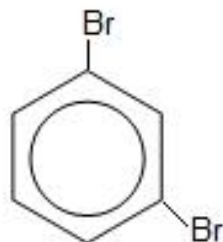

- dibromocyclohexene
 - 1,3-dibromocyclohexatriene
 - 1,3-dibromobenzene
 - 2,4-dibromobenzene
- Which formula represents an aromatic compound?
 - C_2H_2
 - C_6H_6
 - C_6H_8
 - C_6H_{14}
 - How many different possible structures of trichlorobenzene exist?
 - 1
 - 2
 - 3
 - 4
 - Name the following structures.

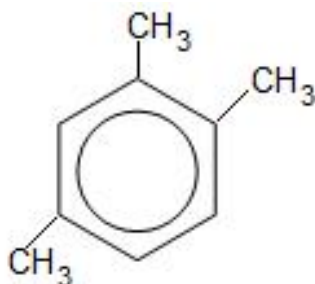

a.

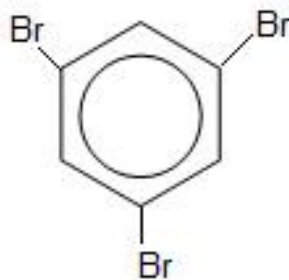

b.

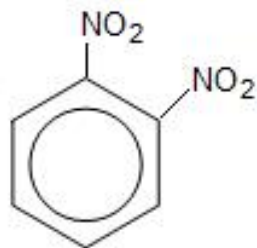

c.

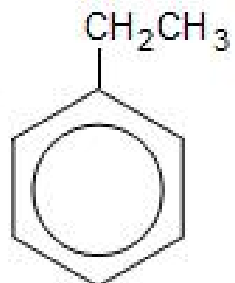

d.

7. Draw the following structures.

- fluorobenzene
- p*-diethylbenzene
- 3-phenylhexane
- 2-methyl-1,4-diethylbenzene

25.4 Functional Groups

Lesson Objectives

The student will:

- define and give examples of functional groups.
- identify alcohols, aldehydes, ketones, ethers, organic acids, and esters based on their functional groups.
- name and draw simple alcohols, aldehydes, ketones, ethers, organic acids, and esters.

Vocabulary

- alcohol
- aldehyde
- carbonyl group
- ester
- ether
- hydroxyl group
- ketone
- organic acid

Introduction

Earlier in this chapter, we were introduced to several functional groups, including alkenes and alkynes. Remember that a functional group is an atom or a group of atoms that replaces hydrogen in an organic compound and is responsible for the characteristic properties of the compound. Functional groups can be used to identify different categories of organic compounds. In this lesson, six of these categories will be studied in terms of their functional groups: the alcohols, aldehydes and ketones, ethers, organic acids, and esters.

Alcohols

Alcohols have the same general formula as an alkane, but alcohols also have the functional group -OH , called the **hydroxyl group**. In terms of solubility, alcohols are soluble in water if the number of carbon atoms is low (three or less). If, however, the number of carbon atoms increases, the solubility decreases accordingly.

The most common alcohol, known as ethanol, is used in alcoholic drinks, as a fuel (gasohol), in thermometers, as a preservative for biological specimens, and as a solvent for paints and drugs. The structure for ethanol is shown below. Notice the hydroxyl group on the end of the two carbon chain.



Butanol, an alcohol with four carbon atoms, is used in paint thinners and in the cosmetic industry. The four different isomers of butanol are shown in the figure below.

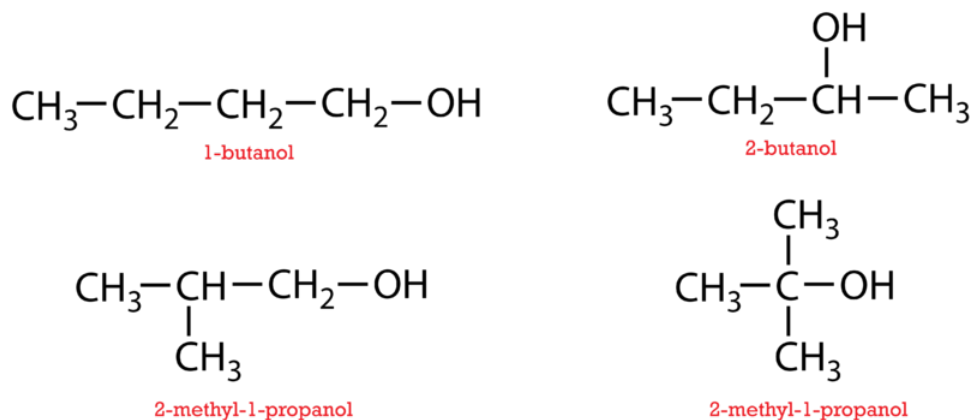

Naming and Drawing Simple Alcohols

In naming alcohols, the suffix “-ol” is added to the parent chain of the alkane name. The position of the –OH functional group is indicated in the name. Remember to start numbering the parent chain on the end closest to where the –OH is located.

Example:

Name the following:

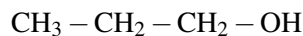

Solution:

The carbon chain contains 3 carbon atoms and an –OH group at one end of the chain.

Therefore, the molecule is 1-propanol.

Alcohols can be classified as primary (1°), secondary (2°) and tertiary (3°) alcohols, as shown below.

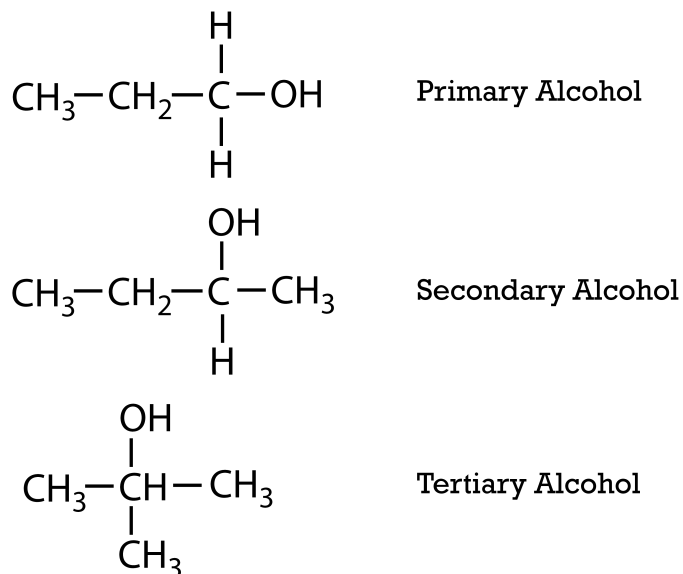

1-propanol is a primary alcohol because the carbon atom that the hydroxyl group is attached to is connected to only one alkyl group. In other words, carbon 1 in 1-propanol is attached to -OH , two hydrogen atoms, and an ethyl group. Therefore, 1-propanol is a 1° alcohol.

An example of a secondary (2°) alcohol is 2-butanol. Notice in 2-butanol that the carbon atom to which the hydroxyl group is bounded to is also connected to a methyl group on the right and an ethyl group on the left.

In comparison, 2-methyl-2-propanol is a tertiary (3°) alcohol. If you look at this structure, the carbon atom bounded to the hydroxyl group is also bounded to three methyl groups.

As with the other organic compounds introduced in this chapter, alcohols can be drawn by looking at the name of the compound and analyzing what the name tells about the structure of the compound.

Example:

Draw the structure of 2-pentanol.

Solution:

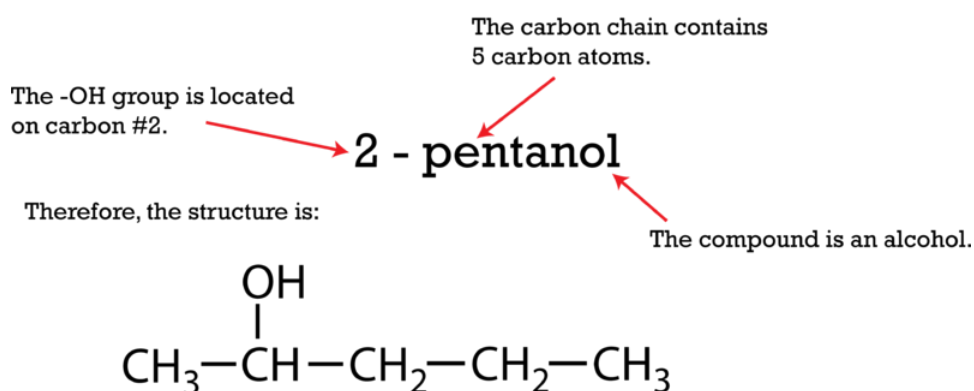

Aldehydes and Ketones

The **aldehydes** and **ketones** contain what is known as the carbonyl group. A **carbonyl group** is a carbon atom double bonded to an oxygen atom ($\text{C} = \text{O}$), and the carbon is also bounded to two other atoms or groups. In an aldehyde, the carbonyl group is always on an end carbon. In a ketone, the carbonyl group is never on an end carbon. Look at the diagram below to compare the location of the carbonyl group in ethanal (an aldehyde) and 2-butanone (a ketone).

Ethanal

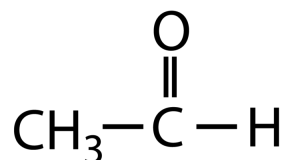

2 - butanone

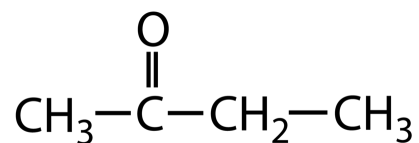

Aldehydes

Aldehydes play an important role in our everyday lives. Those that have higher molecular masses are responsible for some very pleasant smells that you may have experienced in your own home. Benzaldehyde is an aldehyde responsible for the baking ingredient almond extract, while the smell of vanilla is due partially to an aldehyde component in the structure methoxybenzaldehyde (structure of vanilla is shown below).

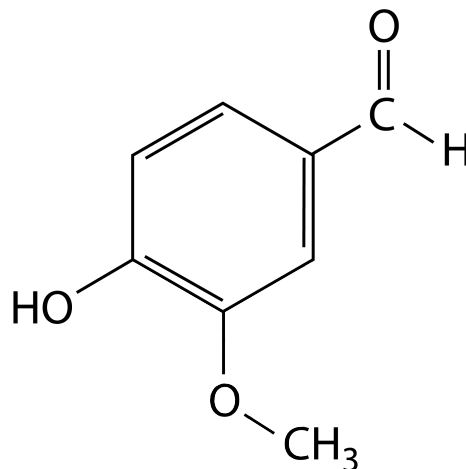

Vanilla
(4-hydroxy-3-methoxybenzaldehyde)

Of course, other aldehydes, such as formaldehyde, do not smell as nice. Formaldehyde is used as a preservative for organs and as an embalming fluid. Acetaldehyde is the oldest known aldehyde (more than 300 years old) and has its use in the preparation of ethanol.

Naming and Drawing Aldehydes

In order to name aldehydes, use the parent chain name of the alkane and add the suffix “-al.” Remember that all aldehydes have the general formula shown below.

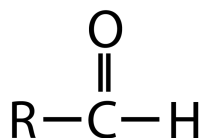

In the general formula above, R represents a hydrogen atom or any alkyl group. The simplest aldehyde is methanal, where R = H.

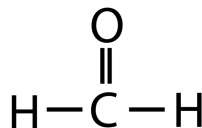

Example:

Name the following structure:

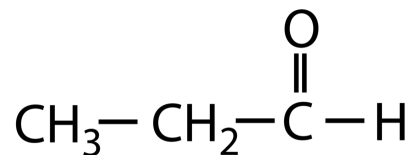
**Solution:**

The parent chain contains 3 carbon atoms, and it has a carbonyl group on the end of the chain. Therefore, the name is propanal.

Example:

Draw the structure of pentanal.

Solution:

Pentanal has the prefix “pent-,” meaning it has five carbon atoms.

Pentanal has the suffix “-al,” meaning it has the aldehyde functional group

Therefore, the structure is:

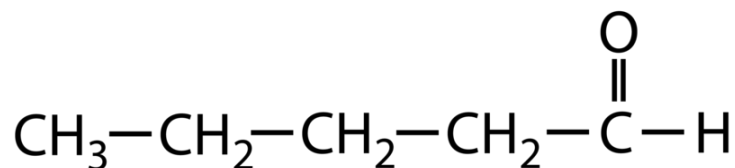
**Ketones**

Ketones are equally as important as aldehydes in our daily lives. Ketones are present in the body when fat is broken down for energy. A buildup of ketones leads to ketoacidosis, a potentially dangerous condition. Acetone is also a ketone and is the main component in finger nail polish. Carvone is a ketone that is found in many naturally occurring products, such the oils from mandarin oranges, dill seeds, and spearmint. Another example of a useful ketone is isophorone (3,5,5-trimethyl-2-cyclohexene-1-one), which is used in some paints to improve the flow and increase the glossiness. Isophorone has the structure shown below.

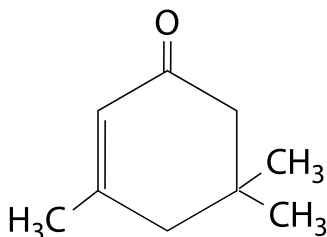

Isophorone

Naming and Drawing Ketones

In order to name compounds that are ketones, use the parent chain name of the alkane and add the suffix “-one.” For parent chains more than four carbon atoms, the position of the carbonyl group must be indicated. Remember that all ketones have the general formula shown below.

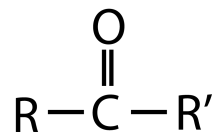

In the general formula above, R and R' are both alkyl groups, which can be the same or different. The simplest ketone is propanone (acetone), where R and R' are both methyl groups.

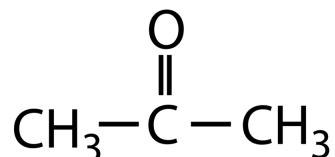
**Example:**

Name the following structure.

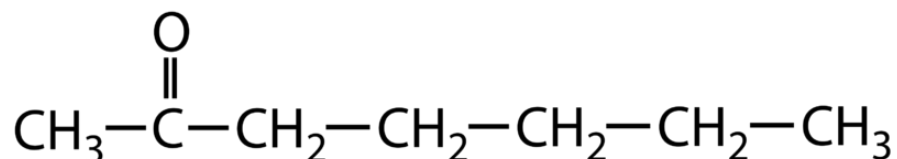
**Solution:**

There are alkyl groups attached on both sides of the carbonyl group, therefore the molecule is a ketone. The name of this compound is 2-heptanone.

Example:

Draw the structure of 3-pentanone.

Solution:

The carbon chain will be 5 carbon atoms long, and it will have a carbonyl group at carbon 3. Therefore, the structure is:

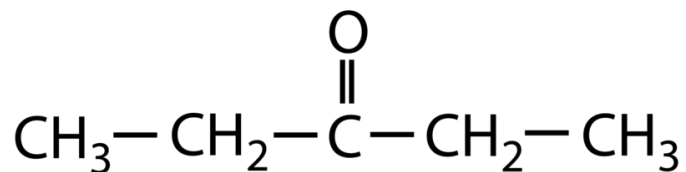

Ethers

All **ether** compounds have the general formula $\text{R}-\text{O}-\text{R}'$, where R and R' are both alkyl groups, which could either be the same or different. The most common ether is a compound also known as diethyl ether. The structure of diethyl ether is shown below:

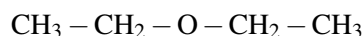

In this structure the alkyl groups on either side of the oxygen atom are ethyl groups, hence the name diethyl ether. Diethyl ether was first publicly demonstrated as an anesthetic in 1846 at Massachusetts General Hospital. It was considered at the time to be a great breakthrough because it produced the ability for physicians to provide “painless” surgery. Today it also has other uses, such as a solvent for fats and oils. It is also sometimes used to anesthetize ticks before removing them from the skin. The harmful side effects and highly flammable nature of the compound, however, makes its use less common today than in past eras.

Naming and Drawing Ethers

There are two possible ways to name ethers. One way is to name the alkyl groups on either side of the ether functional group and then adding the word “ether” on the end. The other possibility is to name the smaller alkyl group, add the suffix “-oxy,” and then give the alkane name to the larger alkyl group. The alkyl groups are named in alphabetical order.

Example:

Draw the structure for ethyl methyl ether.

Solution:

The general structure is $R - O - R'$. Looking at the name of the structure, we can determine what alkyl groups will be the R and the R'.

Let $R = \text{CH}_3\text{CH}_2$ and let $R' = \text{CH}_3$, then draw the structure.

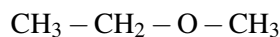

Note this structure is also called methoxy ethane.

Organic Acids

The **organic acids** (or carboxylic acids) contain the carboxyl group. A **carboxyl group** is a carbon atom double bonded to an oxygen atom ($\text{C} = \text{O}$), a hydroxyl group ($-\text{OH}$), and either a hydrogen atom or an alkyl group. Carboxylic acids are often found in nature and often combined with other functional groups. Many of these compounds are liquids or solids with low melting points. Carboxylic acids are also highly soluble in water and have a relatively low pH. Vinegar is a water solution containing 5% of the common carboxylic acid acetic acid (shown below).

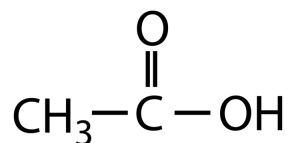

Another common carboxylic acid is niacin (Vitamin B₃). Niacin (shown below) is found in carrots, green leafy vegetables, milk, eggs, and some fish. It is used by the body to aid metabolism, DNA repair, and the functioning of the adrenal gland.

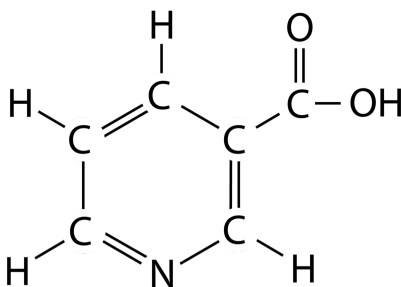

The formula for the carboxyl group is written as R – COOH, where R is a hydrogen atom or an alkyl group. The general formula for the organic acid is found in the diagram below.

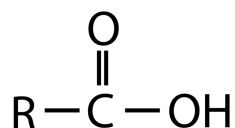

Organic acids play a key role in many aspects of our lives. For example, citric acid is the taste you experience when you drink citrus drinks such as orange juice or put lemon juice on fish. Aspirin (acetylsalicylic acid or ASA) is a widely used pain killer. Oxalic acid is a naturally occurring organic acid found in the leaves of, among other plants, rhubarb, star fruit, black pepper, and parsley. The structures of these organic acids are shown below.

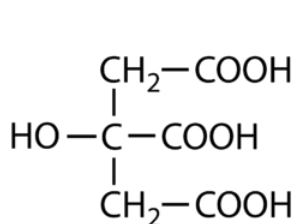

Citric Acid

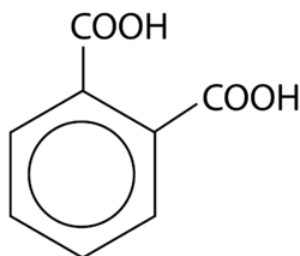
Aspirin
(acetylsalicylic acid)

Oxalic Acid

Naming and Drawing Organic Acids

The simplest of organic acids is one where the R group is hydrogen.

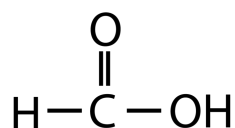

When R = H in the general formula, the organic acid is methanoic acid. Methanoic acid (or formic acid) is commonly used in the recycling industry, especially for recycling rubber. It is found in the venom of bees and ants and is released when an insect bites.

When naming organic acids, use the parent chain name of the alkane and add the suffix “-oic acid.”

Example:

Name the following structure.

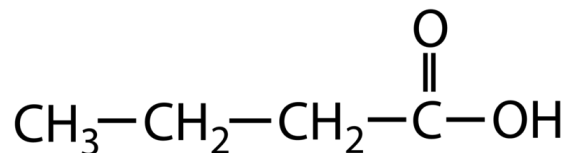
**Solution:**

This molecule is a 4-carbon chain ending with a carboxylic acid group. Therefore, the name is butanoic acid.

Example:

Draw the structure of 2-methyl propanoic acid.

Solution:

Methyl (CH_3) is a branch found on carbon 2.

Propanoic has the prefix “prop-,” meaning it has three carbon atoms in the parent chain. The suffix “-oic acid” means that it has the organic acid functional group. Therefore, the structure is:

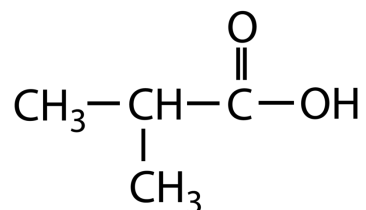

Esters

Have you ever wondered why an orange has such a wonderful aroma, or where the smell from a freshly cut pineapple comes from? Most fruits get their rich aroma from molecules known as **esters**. Octyl ethanoate is responsible for the smell for oranges, while butyl butanoate is best known for the smell of pineapple.

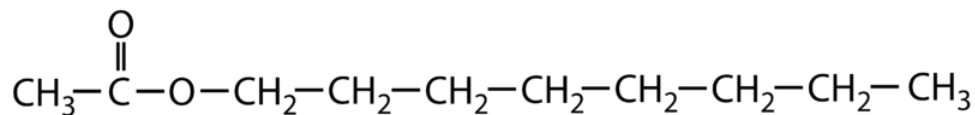

Octyl ethanoate (orange flavor)

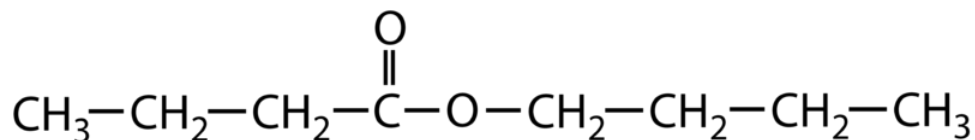

Butylbutanoate (pineapple flavor)

Actually, quite a few of the scents that we are familiar with can be traced back to an ester. Look at **Table 25.6** at some of the common scents and the ester for which the scent can be attributed to.

TABLE 25.6: Scents and Their Esters

Scent	Ester
Apples	Methylbutanoate
Pears	Propylethanoate
Raspberries	2-methylpropylethanoate
Peach	Ethylbutanoate
Banana	3-methylbutylethanoate
Orange	Octylacetate
Jasmine	Benzylethanoate

Naming and Drawing Esters

The general formula for esters is found below.

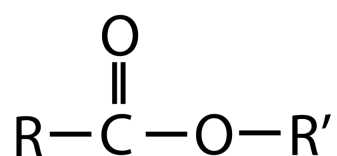

Notice that the general formula looks similar to the organic acid, but in the case of the ester, the carboxylic acid hydrogen has been replaced with a second alkyl group. This is because esters can be produced by a reaction between an organic acid and an alcohol. This general reaction can be represented as:

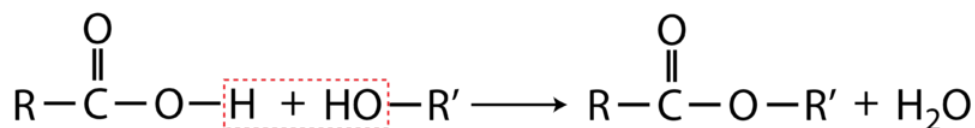

A specific example of this type of reaction is:

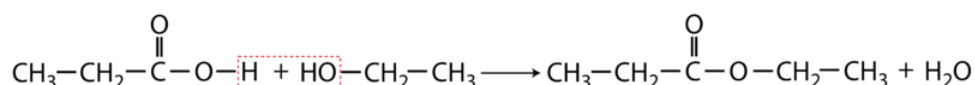

Since esters have an alkyl group on either side of the functional group, the name of the ester will be in two pieces. As was described earlier, esters are formed from organic acids and alcohols. The alkyl group from the organic acid is R. The alkyl group from the alcohol is R'. The name of an ester is composed of the name of the alkyl group from the alcohol, then of the alkyl group from the organic acid, and finally the suffix “-oate.” A sample reaction for a general reaction and then a specific reaction to demonstrate this principal is shown below.

To draw an ester, remember that the first alkyl group is attached to the oxygen and the alkyl group with the suffix “-oate” is part of the C = O chain.

Example:

Name the following structure:

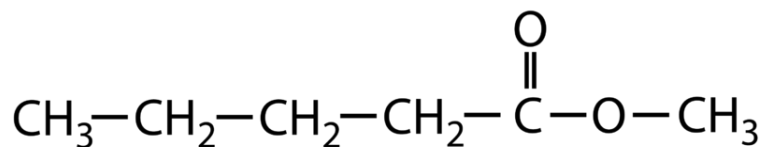

Solution:

The name of this compound is methyl pentanoate (the odor of apple).

Example:

Draw the structure of ethyl heptanoate (the odor of red grapes).

Solution:

Ethyl (CH_3CH_2) is listed first and is therefore from the alcohol, so it will be attached to the oxygen.

Heptanoate is named second and is therefore from the organic acid. Heptanoate has the prefix “hept-,” meaning that it has seven carbon atoms in the parent chain. Heptanoate also has the suffix “-oate,” meaning it has the ester functional group

Therefore, the structure is:

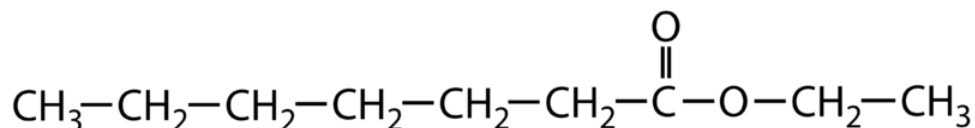

This video shows an example of naming some compounds containing functional groups (10e), see http://www.youtube.com/watch?feature=player_profilepage&v=nuLxS4SZ4zU (4:38).

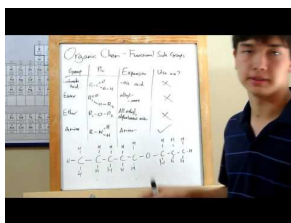
**MEDIA**

Click image to the left for more content.

Categories of Organic Compounds

In the table below is a summary of the organic compounds studied in this chapter. **Table 25.7** lists the general formula and the functional groups for the alkanes, the alkenes, the alkynes, and the substituted halogens along with the aromatics, as well as the six new categories introduced in this lesson. An example from each category is also provided.

TABLE 25.7: Summary of the Categories of Organic Compounds

Category	General Formula	Distinguishing Feature	Example Formula	Name
Alkane	NA	All single C – C bonds	$\text{CH}_3\text{CH}_2\text{CH}_3$	propane
Alkenes	NA	One C = C bonds	$\text{CH}_2 = \text{CH}_2$	Ethene
Alkynes	NA	One C \equiv C bond	$\text{HC} \equiv \text{CH}$	Ethyne

TABLE 25.7: (continued)

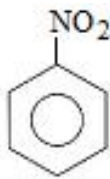
Category	General Formula	Distinguishing Feature	Example Formula	Name
Aromatic	NA	Benzene ring part of structure, Benzene-like structure		Nitrobenzene (floor polish)
Substituted Halogens	$R - X$	One or more of halogens attached to organic compound	CH_2FCI	Chlorofluoromethane (Freon)
Alcohol	$R - OH$	Hydroxyl group	$CH_3CH_2 - OH$	Ethanol
Ether	$R - O - R'$	$C - O - C$	$CH_3 - O - C_2H_5$	Methyl ethyl ether
Aldehydes	$R - \overset{\overset{O}{\parallel}}{C} - H$	$- \overset{\overset{O}{\parallel}}{C} - H$	$CH_3 - \overset{\overset{O}{\parallel}}{C} - H$	Ethanal
Ketone	$R - \overset{\overset{O}{\parallel}}{C} - R'$	$- \overset{\overset{O}{\parallel}}{C} -$ (Carbonyl group)	$CH_3 - \overset{\overset{O}{\parallel}}{C} - C_2H_5$	Butanone
Organic Acids	$R - \overset{\overset{O}{\parallel}}{C} - OH$	$- \overset{\overset{O}{\parallel}}{C} - OH$ (Carboxyl group)	$CH_3 - \overset{\overset{O}{\parallel}}{C} - OH$	Ethanoic acid
Ester	$R - \overset{\overset{O}{\parallel}}{C} - O - R'$	$- \overset{\overset{O}{\parallel}}{C} - O -$	$C_3H_7 - \overset{\overset{O}{\parallel}}{C} - O - C_4H_9$	Butyl butyrate (pineapple)

Lesson Summary

- Alcohols have the same general formula as an alkane, except alcohols have the functional group $-OH$, called the hydroxyl group.
- Primary (1°) alcohols have a carbon atom attached to a hydroxyl group and one alkyl group. Secondary (2°) alcohols have a carbon atom that is attached to a hydroxyl group and two alkyl groups. Tertiary (3°) alcohols have a carbon atom that is attached to a hydroxyl group and three alkyl groups.
- All aldehydes have the general formula below:

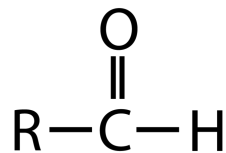

- In order to name aldehydes use the parent chain name of the alkane and add the suffix “-al.”
- All ketones have the general formula below:

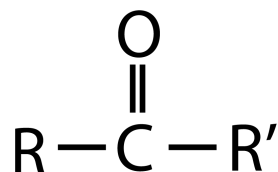

- To name ketones, use the parent chain name of the hydrocarbon and add the suffix “-one.”
- A carbonyl group is a carbon atom double bonded to an oxygen atom (C = O) and to two other atoms or groups.
- All ether compounds have the general formula R – O – R', where R and R' are alkyl groups.
- Ethers can either be named by naming the alkyl groups on both sides of the ether functional group and then adding the word “ether” on the end. The other possibility is to name the smaller alkyl group, add the suffix “-oxy,” and then giving the alkane name to the larger alkyl group.
- The organic acids (or carboxylic acids) contain the carboxyl group (C = O), a hydroxyl group (–OH), and either a hydrogen atom or an alkyl group. The formula for the carboxyl group is written as R – COOH, where R is a hydrogen atom or an alkyl group.
- The general formula for the organic acid is below:

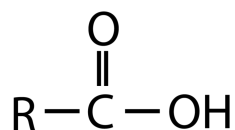

- When naming organic acids use the parent chain name of the alkane and add the suffix “-oic acid.”
- The general formula for an ester is shown below:

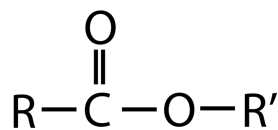

- When naming an ester, the name is composed of the alkyl group from the alcohol, then the alkyl group from the organic acid, and then the suffix “-oate.”

Further Reading / Supplemental Links

The *learner.org* website allows users to view streaming videos of the Annenberg series of chemistry videos. You are required to register before you can watch the videos but there is no charge. The website has one video that relates to this lesson called “Carbon.” The versatility of carbon’s molecular structures and the enormous range of properties of its compounds are presented.

- http://www.learner.org/vod/vod_window.html?pid=813

Review Questions

1. Complete the following chart (**Table 25.8**).

TABLE 25.8:

Group	Distinguishing Feature	Draw Example (with Name)
Alcohol		
Aldehyde		
Ketone		
Ether		
Organic Acid		
Ester		

2. What is the difference between the carbonyl group in the aldehydes and the carbonyl group in the ketones? Give an example to illustrate your answer.
3. Which of the following compounds is an alcohol?
 - a. $\text{CH}_3\text{COOCH}_3$
 - b. $\text{CH}_3\text{CH}_2\text{OH}$
 - c. CH_3COOH
 - d. CH_3COCH_3
4. To which family of organic compounds does $\text{CH}_3\text{COCH}_2\text{CH}_3$ belong?
 - a. alcohol
 - b. aldehyde
 - c. ketone
 - d. carboxylic acid
5. Which of the following classes of organic compounds contain a carbon-oxygen double bond: i. alcohols, ii. aldehydes, iii. ketones, iv. ethers, v. organic acids, vi. esters?
 - a. i, iii, and iv only
 - b. ii, iv, and vi only
 - c. i, iii, iv, and v only
 - d. ii, iii, v, and vi only
6. What is the name of the compound represented below?

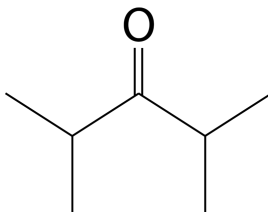

- a. heptanone
- b. 2,3-dimethyl-3-pentanone
- c. 2,3-dimethylpentanone
- d. diisopropyl ketone

7. Name the following compounds

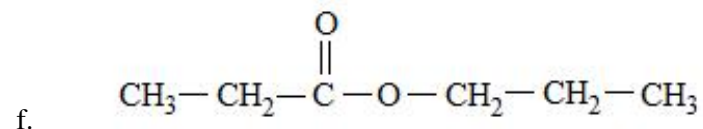
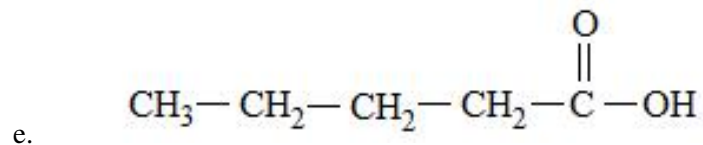
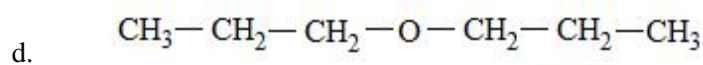
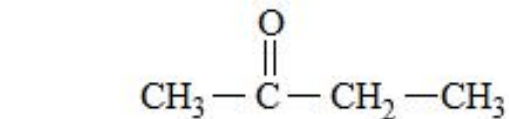
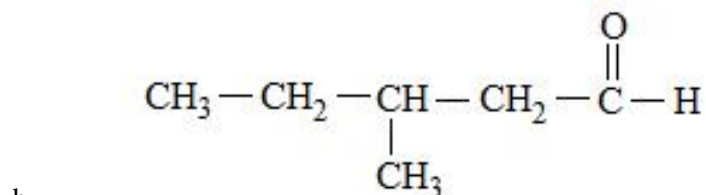
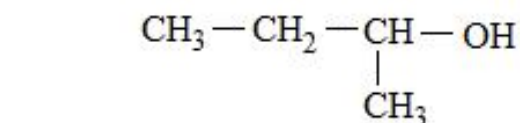

8. Draw the following compounds.

- 3-ethyl-2-hexanol
- 2,2-dimethylpropanal
- 2-propanone
- dibutyl ether
- methanoic acid
- methyl butanoate

25.5 Biochemical Molecules

Lesson Objectives

The student will:

- describe the basic structure of fatty acids, monosaccharides, and proteins.
- identify the chemical purpose fulfilled by lipids, carbohydrates, and enzymes.
- describe the biological function of hemoglobin and DNA.

Vocabulary

- amino acid
- biochemistry
- carbohydrate
- dipeptide
- DNA
- enzyme
- fatty acid
- lipids
- phospholipid
- polymer
- polypeptide
- protein
- steroid

Introduction

Biochemistry is the study of the structure and properties of molecules in living organisms. In a full course in biochemistry, you would study how those molecules are made, changed, and broken down. Examples of the types of molecules important to biochemistry are proteins, hormones, and nucleosides.

This video details the discovery of organic molecules on extrasolar planets (**11 IE**): <http://www.youtube.com/watch?v=Lxs9Pmxy5MA> (5:04).

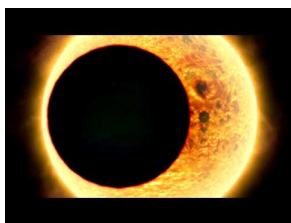

MEDIA

Click image to the left for more content.

Lipids

Otherwise known as fats and oils (triglycerides), **lipids** are produced for the purpose of storing energy. One of the best known lipids is cholesterol, which is used in the body to construct cell membranes and as a building block for some hormones. High levels of cholesterol are linked to coronary disease.

There are many categories of lipids, but the three main categories are:

1. fatty acids
2. steroids
3. phospholipids

Fatty acids are molecules with a carboxylic acid group at one end, while the remainder of the molecule is a hydrocarbon chain having anywhere from four to thirty-six carbon atoms. They can be saturated or unsaturated, and they generally occur as unbranched chains. As with all biochemical molecules, there are good fatty acids as well as bad.

Omega-3 fatty acid (linolenic acid) is a beneficial fatty acid, cited as slowing the buildup of atherosclerotic plaques. Omega-3 fatty acids have been shown to regulate the immune system and to lower blood pressure. The structure of omega-3 is shown below. It is found in seed oils, fish, and in egg yolks. Since the body cannot produce these particular fatty acids, food is the only source of this type of lipid. Therefore, omega-3 is known as an essential fatty acid.

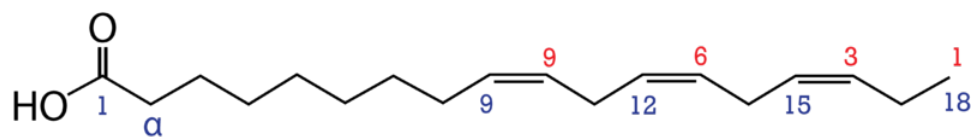

Notice that omega-3 fatty acid has a carboxylic acid functional group on one end and a terminal methyl group on the other end. It also has three double bonds, one at carbon 9, one at carbon 12, and one at carbon 15, giving this fatty acid its unique structure.

Steroids are compounds where four carbon rings are bounded together with branches and functional groups bounded to the rings. Depending on the combinations of the rings, branches, and functional group, different steroids can be formed with different functions in the body. The diagram below shows the structures of lanosterol and corticosterone. In lanosterol, notice that the four rings, the hydroxyl group, and the number of branches from the carbon rings. Lanosterol has 30 carbon atoms in total and acts as the basic building block for all steroids. Corticosterone is a steroid hormone important in mobilizing the immune system to fight infection. Notice the similarity in the structures to lanosterol.

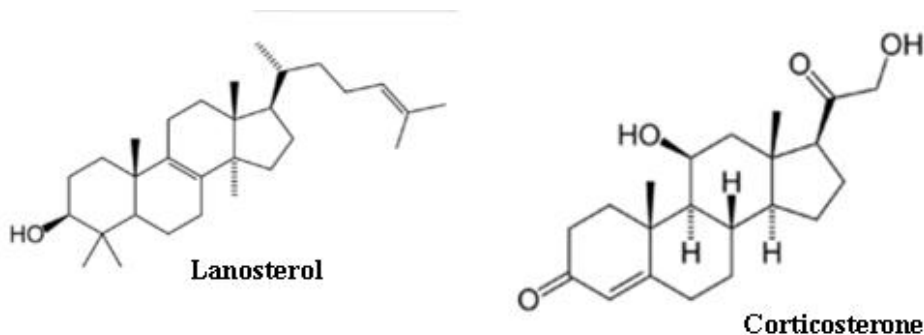

Phospholipids are a combination of fatty acids, glycerol, and a phosphate group joined together. Phospholipids play a major role in cell membranes. The figure below shows phosphatidyl choline, which is the major component of

lecithin. Lecithin is present in egg yolk and soy beans, among other foods. Notice the position of the links between the amine, the phosphate group, the glycerol, and the fatty acids.

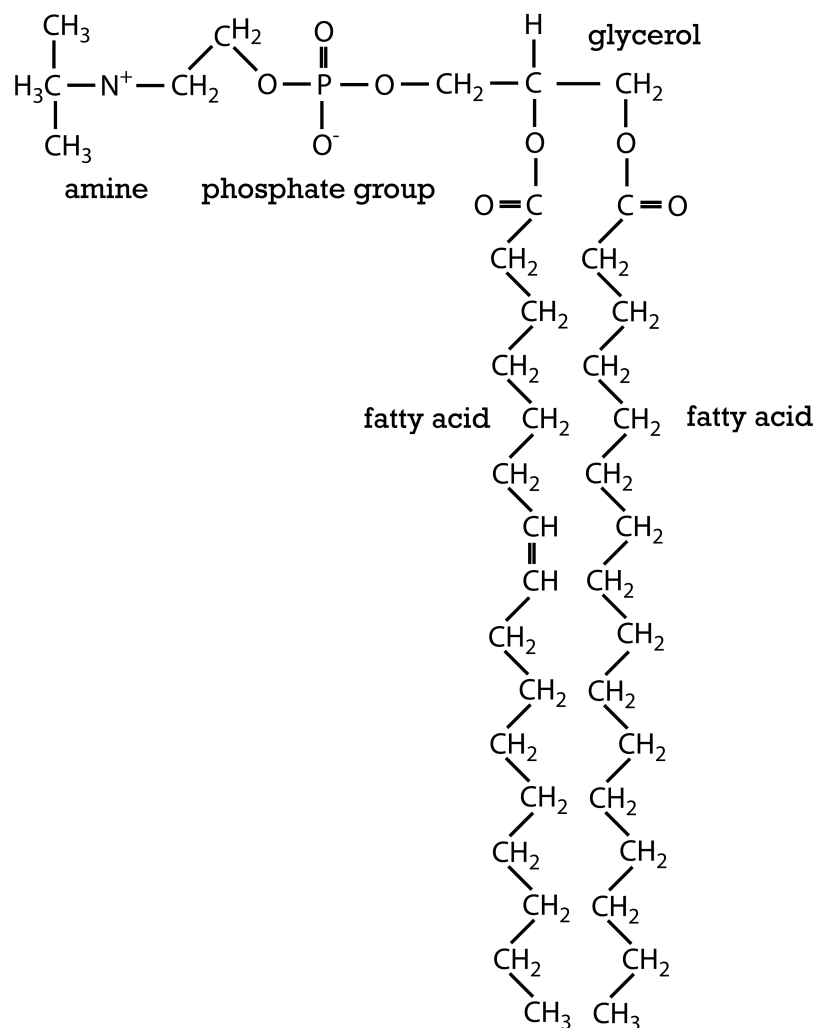

Carbohydrates

Carbohydrates supply the necessary energy living systems need to survive. All carbohydrates contain carbon, hydrogen, and oxygen and have the general formula $C_x(H_2O)_y$. These molecules are also known as sugars or sugar chains that perform specific functions depending on their structure. Carbohydrates can be classified into three different categories:

1. monosaccharides
2. disaccharides
3. polysaccharides

Monosaccharides and disaccharides are also known as simple sugars. Refined white sugar commonly found in the home is an example of a simple sugar. More precisely, refined white sugar is the simple sugar sucrose. Sucrose is a disaccharide formed when two monosaccharides (glucose and fructose) join. A **monosaccharide** is a single sugar unit whereas a **disaccharide** has two sugar units. Illustrations of sucrose, glucose, and fructose are shown below. Notice that the bond joining the two monosaccharide units in sucrose. The molecule on the left in sucrose is

a glucose molecule, while the molecule on the right is a fructose molecule. As the two monosaccharides join, both glucose and fructose will lose a hydrogen atom and one of the molecules will also lose an oxygen atom when they join to form the disaccharide.

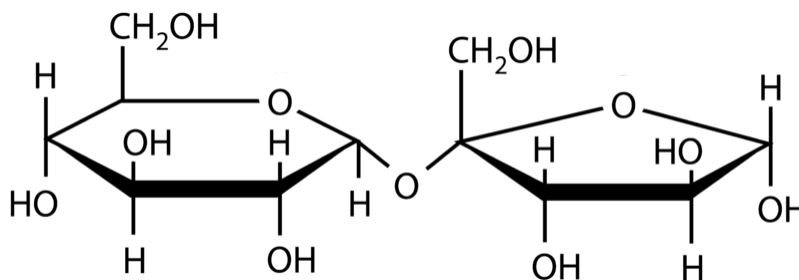

Sucrose: a disaccharide

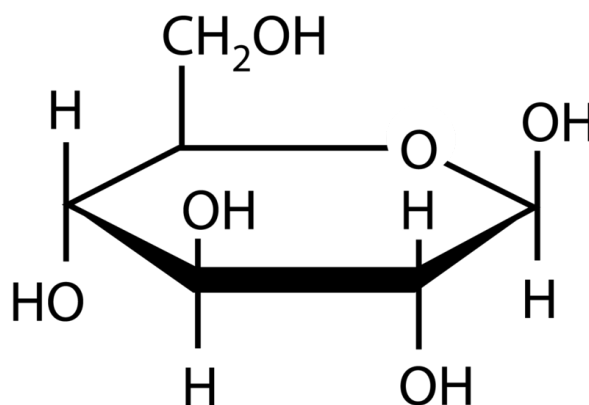

Glucose: a monosaccharide

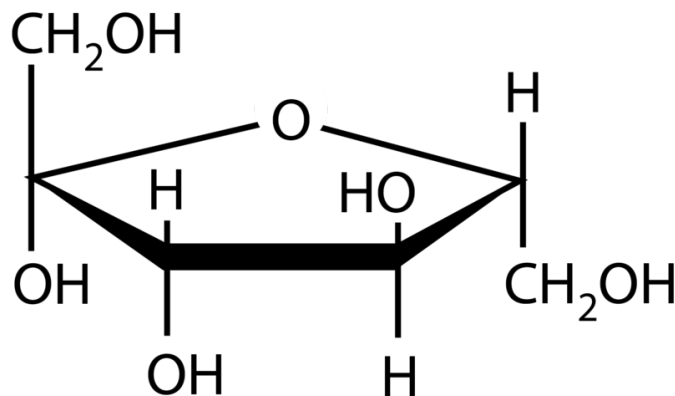

Fructose: a monosaccharide

Within polysaccharides, there are numerous individual sugar units. Starches, for example, are polymers where a large number of glucose monosaccharides join together. Starches have the general formula $(C_6H_{10}O_5)_n$, where n is dependent on the type of starch formed. For example, glycogen is an animal starch that is made up of approximately 60,000 glucose units. Glycogen is important as a source of energy storage in both the liver and in muscles. When an organism needs that energy, degradation enzymes release the glucose units. Notice in the diagram below how the glucose molecules are linked together in glycogen.

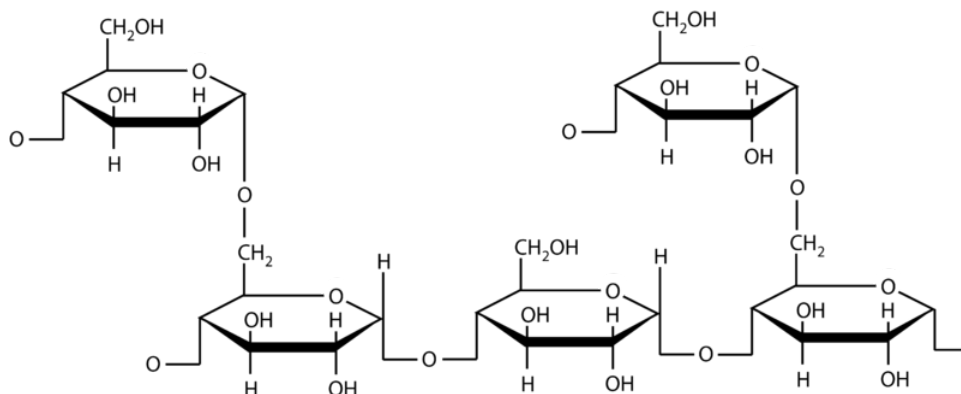

Proteins

A **polymer** is a large organic molecule that contains hundreds or even thousands of atoms. **Amino acids** are molecules that contain an amine group ($-\text{NH}_2$) and a carboxylic acid group ($-\text{COOH}$). There are twenty different naturally occurring amino acids that differ only in the R group that separates the amino group from the carboxyl group. When amino acids join together, the link that joins them is called a peptide bond. The diagram below shows the formation of the dipeptide bond.

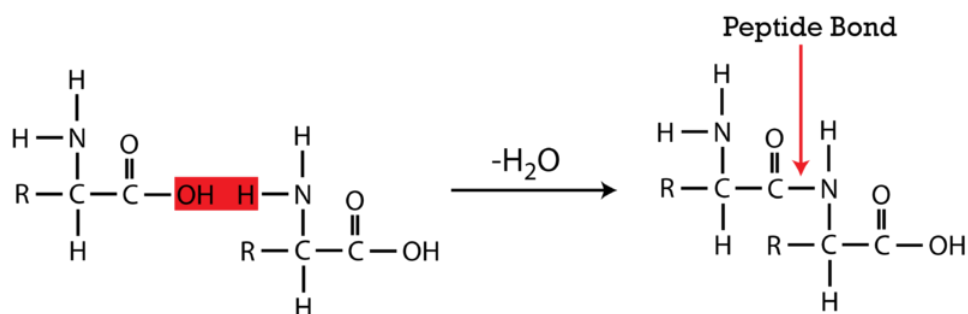

Two amino acids joining is a **dipeptide**. When many amino acids combine together, a **polypeptides** will form. A **protein** is a combination of these polypeptides or long chains of amino acids. Proteins are essential to the structure and function of all biological cells. **Figure 25.4** shows a 3D model of the protein myoglobin, which is a marker for damaged muscle tissue. It is released when the muscle tissue is damaged. It is a polypeptide made from a chain of 153 linked amino acids.

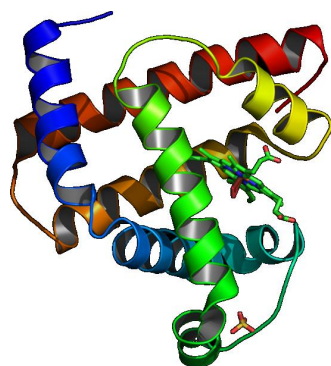

FIGURE 25.4

Representation of a 3D model of a protein.

Other proteins that are essential to our life include keratin, collagen, actin, myosin, and hemoglobin. Hair and nails contain keratin, tooth enamel and bones are made from collagen, and muscle tissue contains actin and myosin. Hemoglobin is the most complex of the human proteins and is used to transport oxygen in the blood.

There are four different types of structures that proteins form in the body:

1. primary (1°) structures
2. secondary (2°) structures
3. tertiary (3°) structures
4. quaternary (4°) structures

Primary (1°) structures are linear chains of amino acids where the peptide bonds link the amino acids together in long chains or sheets. An example of the primary structure of protein is shown in **Figure 25.5**.

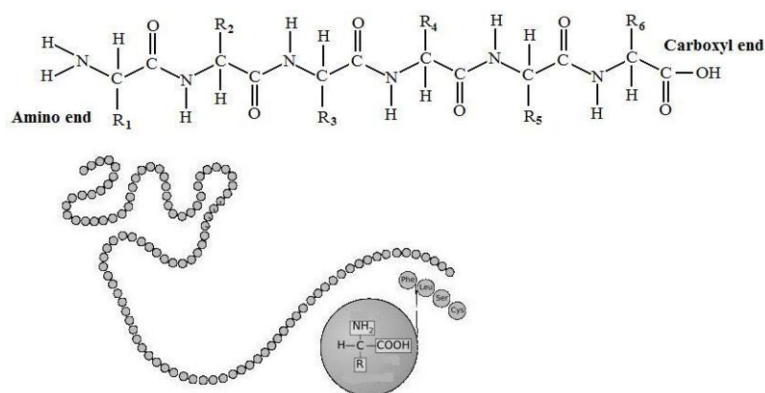
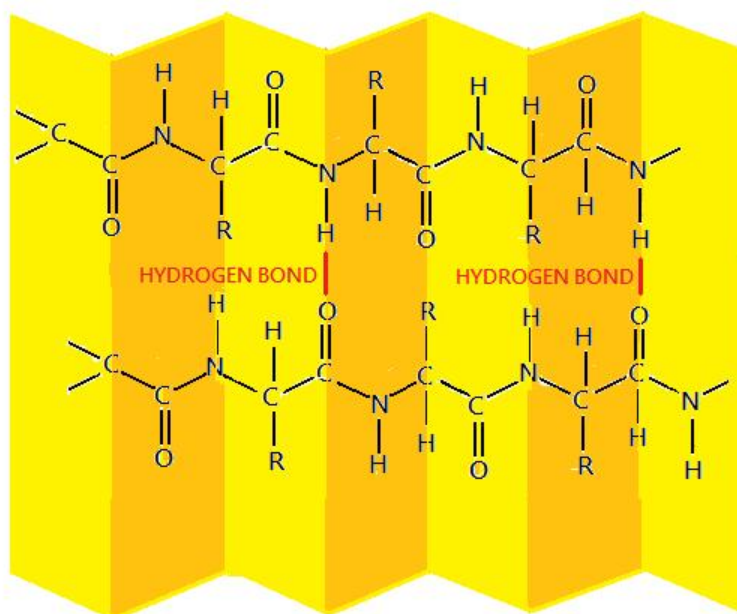

FIGURE 25.5

Primary structure of a protein.

Secondary (2°) structures can form pleated sheets where hydrogen bonds are formed between the amine groups and the carboxylic acid groups of the amino acids in the peptide link (see **Figure 25.6**).

These structures can also form alpha-helix formations where hydrogen bonds connect the amino acids in the peptide link and the carboxylic acid groups in amino acids further down the protein chain. The diagram below shows the structure for the alpha helix. Notice the coiled structure versus the more straightened structure of the pleated sheet.



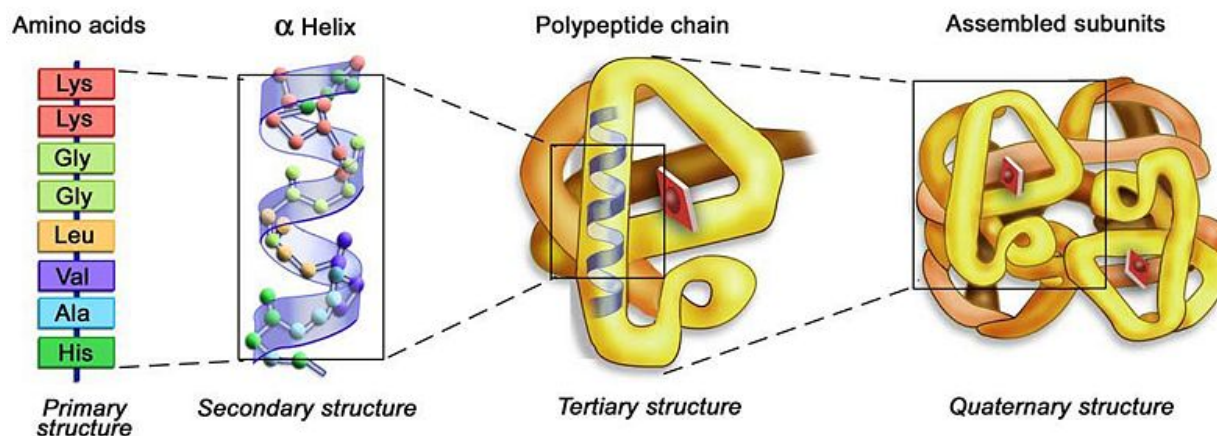

FIGURE 25.6

Pleated Sheet of the Secondary Structure

Tertiary (3°) structures form helical structures as pleated sheets and alpha-helices join together in the same molecule. The structure of myoglobin shown above (in **Figure 25.4**) shows the strings of the pleated sheets and the coils of the alpha-helix structures. There is hydrogen bonding between amino hydrogen atoms and carbonyl oxygen atoms with the secondary structures, as well as bonding between the amino acids.

Lastly, quaternary (4°) structures occur when two or more polypeptides join together. The quaternary structure of hemoglobin, (**Figure 25.7**) the principal oxygen-carrying protein found in red blood cells, is a combination of four structural units similar to the tertiary structure of myoglobin.

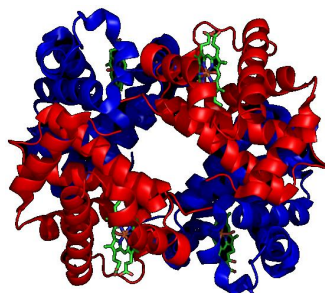
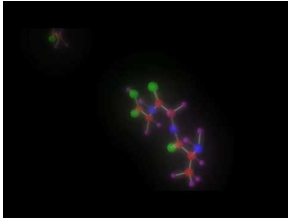

FIGURE 25.7

Hemoglobin

This video shows an animation of the formation of a protein (10a, 10c; 11 IE Stand.): <http://www.youtube.com/watch?v=w-ctkPUUpUc> (4:00).



MEDIA

Click image to the left for more content.

This video explains how amino acids form the polypeptide backbone structure of proteins (**10f; 11 IE Stand.**): http://www.youtube.com/watch?v=0_WaQniUU-g (2:22).

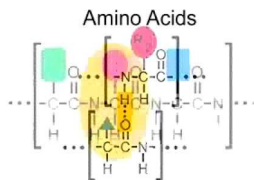

MEDIA

Click image to the left for more content.

Enzymes

Proteins are essential to life, and there are over 10,000 different kinds of proteins in the body. **Enzymes** are a subset of proteins. They are a specific type of protein that speed up chemical reactions, thus acting as biological catalysts. Recall that a catalyst is a substance which accelerates the rate of a chemical reaction without itself undergoing any net change. There are more than 4,000 enzyme reactions that occur in biological systems. One of the earliest known enzymes, known as amylase, was first identified by Anselme Payen in 1833. This enzyme is used in digestion to convert starch to sugar in the body. If you were to chew on a cracker, you would notice that after a while it would start to taste a little sweet in the mouth. This is the enzyme in the saliva beginning to do its job. **Figure 25.8** shows an illustration of amylase. Notice the similarity in structure between enzymes and proteins.

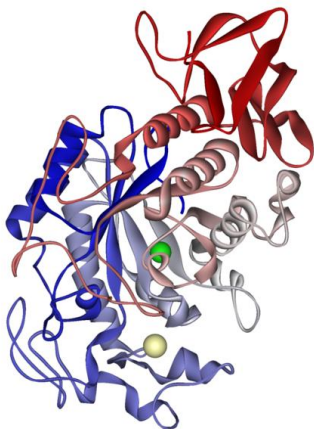

FIGURE 25.8

Amylase

DNA

After a discussion of proteins, the next logical step is to learn about nucleic acids. **DNA** (short for deoxyribonucleic acid), is a polynucleotide found primarily in the nucleus of the cell that maintains our genetic coding. Its function is to direct the body in the synthesis of proteins. The DNA molecule is a large polynucleotide with a molecular weight in the range of 6 million amu. Ribonucleic acids, like RNA, are smaller with molecular weights in the realm of 20,000 to 40,000 amu. A DNA nucleotide consists of one sugar (deoxyribose), a phosphate group, and one of four nitrogen bases. These four nitrogen bases are:

1. adenine (A)
2. thymine (T)
3. guanine (G)
4. cytosine (C)

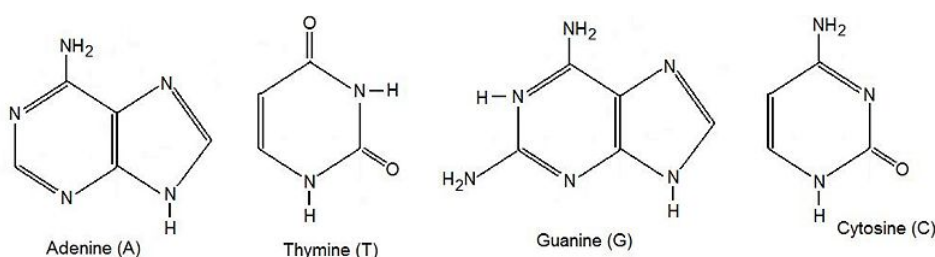

Looking at the structure for deoxyribose (the sugar in the DNA molecule, structure shown in **Figure 25.9**), the phosphate will react and form a link with the hydroxyl groups, forming an outer layer of phosphate-deoxyribose chains. The inner structure of the DNA molecule contains the nitrogen bases. Each nitrogen base has linked to the deoxyribose via a hydroxyl group on the sugar unit, and through hydrogen bonding, these nitrogen bases have complementary linkages to each other (A exclusively links to T, and C connects only to G).

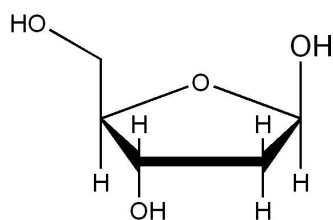

FIGURE 25.9

Deoxyribose

It is interesting to note that the two strands form a double helix (see **Figure ??**), which adds flexibility to the structure, easy storage, and availability of genetic material in addition to ease in the integrity of replication. In order to copy the DNA in cell replication, the double helix unwinds, resulting in two complementary strands, each of which can construct a daughter double helical DNA structure of its own.

Lesson Summary

- Lipids are used for the storage of energy.
- Carbohydrates are also known as sugars or sugar chains, and they supply the necessary energy for living systems.

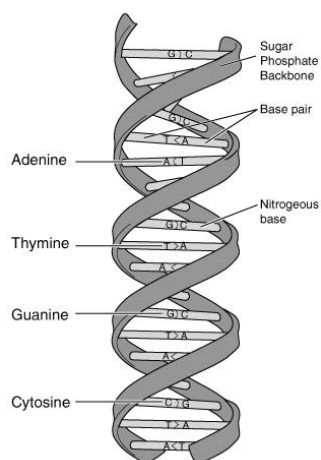

FIGURE 25.10

Illustration of DNA as a double helix.

- Amino acids are building blocks for proteins.
- Enzymes are a special type of protein that speed up chemical reactions and thus act as catalysts.
- DNA contains our genetic coding, its function is to direct the body in synthesizing proteins.

Further Reading / Supplemental Links

The *learner.org* website allows users to view streaming videos of the Annenberg series of chemistry videos. You are required to register before you can watch the videos but there is no charge. The website has one video that relates to this lesson called “Proteins: Structures and Function.”

- http://www.learner.org/vod/vod_window.html?pid=815

This video is a ChemStudy film called “Synthesis of an Organic Compound.” The film is somewhat dated but the information is accurate.

- <http://www.youtube.com/watch?v=ToSmwYgbvI0>

Review Questions

1. Fill in the following table (**Table 25.9**).

TABLE 25.9:

Compound	Main Purpose
Carbohydrate	
Lipid	
Protein	
Enzyme	
DNA	

2. For which biochemical molecule do the triglycerides belong?
738
 - a. carbohydrates
 - b. lipids

5. Starch is a member of what biochemical molecular group?
- carbohydrates
 - lipids
 - proteins
 - enzymes
6. The structure for ribose is shown below. What is the difference between this sugar and the sugar commonly found in DNA?

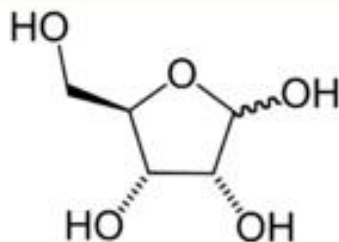

All images, unless otherwise stated, are created by the CK-12 Foundation and are under the Creative Commons license CC-BY-NC-SA.

25.6 References

1. . [Diamond lattice structure](#). CC-BY 3.0
2. Benjah-bmm27. [Graphite structure with multiple layers](#). Public domain
3. Michael Ströck (<http://commons.wikimedia.org/wiki/File:C60a.png>), <http://en.wikipedia.org/wiki/File:Fussball>.
. GNU Free Documentation License, GNU Free Documentation License
4. Aza Toth. [Representation of a 3D model of a protein.](#). Public Domain
5. National Human Genome Research Institute. [Primary structure of a protein](#). Public domain
6. . [Secondary structure of a protein.](#). CC-BY-SA
7. Richard Wheeler. [Hemoglobin](#). GNU Free Documentation
8. . [Amylase](#). Public Domain
9. . [Deoxyribose](#). GNU Free Documentation
10. Courtesy of National Institutes of Health. [DNA Illustration as a double helix](#). Public domain

CHAPTER 26**Chemistry Glossary****Chapter Outline**

26.1	A
26.2	B
26.3	C
26.4	D
26.5	E
26.6	F
26.7	G
26.8	H
26.9	I
26.10	J
26.11	K
26.12	L
26.13	M
26.14	N
26.15	O
26.16	P
26.17	Q
26.18	R
26.19	S
26.20	T
26.21	U
26.22	V
26.23	W
26.24	X
26.25	Y
26.26	Z

26.1 A

absolute zero

the temperature at which molecules stop moving and therefore have zero kinetic energy

accuracy

reflects how close the measured value is to the actual value

acidic salt

a salt formed in a neutralization reaction between a strong acid and a weak base

actinide series

elements with atomic numbers 89 – 102

activation energy

the minimum amount of energy that needs to be supplied to the system so that a reaction can occur

activated complex

a high energy transitional structure that exists just after the bonds in the reactants are broken and before the products are formed

group of un-bonded particles that exist right after the bonds in the reactant have been broken and before the product bonds have formed

actual yield

the actual amount of product that is formed in the laboratory experiment

alcohol

an organic compound that contains the hydroxyl (-OH) group

aldehyde

an organic compound that contains a terminal carbonyl group

alkali metals

Group 1A of the periodic table

alkaline earth metals

Group 2A of the periodic table

alkane

a hydrocarbon containing only single bonds

alkene

a double bond between two carbon atoms, or a hydrocarbon containing a carbon-carbon double bond

alkyne

a triple bond between two carbon atoms, or a hydrocarbon containing a carbon-carbon triple bond

allotropes

different forms of a pure element caused by different bonding arrangements

alloy

a substance with metallic properties composed of a mixture of two or more elements

alpha decay

a common mode of radioactive decay in which a nucleus emits an alpha particle (a helium-4 nucleus)

alpha particle

a helium-4 nucleus

amino acid

a molecule that contains an amine group ($-\text{NH}_2$) and a carboxyl group ($-\text{COOH}$)

amphoteric

a substance that acts as both acids and bases in reactions

amplitude (of a wave)

the “height” of a wave

angular momentum quantum number

a number that describes the sub-shell in which an electron can be found

anion

a negative ion

anode

the electrode at which oxidation occurs

Arrhenius acid

a substance that produces H^+ ions in solution

Arrhenius base

a substance that produces OH^- ions in a solution

artificial radioactivity

induced radioactivity that is produced by bombarding an element with high-velocity particles

atmosphere

unit of pressure equivalent to the pressure under standard conditions at sea level and to 760 mm of Hg

atom

the basic building block of all matter

atomic mass

the weighted average of the masses of the naturally occurring isotopes of an element

atomic mass unit (amu)

used to express atomic and molecular masses, it is the approximate mass of a hydrogen atom, a proton, or a neutron and is one-twelfth of the mass of an unbound carbon-12 atom at rest; it is equivalent to the dalton

atomic number

the number of protons in the nucleus of an atom

atomic radius

one-half the distance between the centers of a homonuclear diatomic molecule

atomos

Democritus's word for the tiny, indivisible, solid objects that he believed made up all matter in the universe

Aufbau principle

states that as electrons are added to "build up" the elements, each electron is placed in the lowest energy orbital available

autoionization

when the same reactant acts as both the acid and the base

Avogadro's law

describes the relationship between the volume and the number of moles of gas

Avogadro's number

the number of objects in a mole; equal to 6.02×10^{23}

26.2 B

background radiation

radiation that comes from environment sources including the earth's crust, the atmosphere, cosmic rays, and radioisotopes

balanced chemical equation

a chemical equation in which the number of each type of atom is equal on the two sides of the equation

barometer

an instrument used to measure atmospheric pressure

base unit

a unit that cannot be expressed in terms of other units, such as the gram (base unit of mass), the meter (base unit of length), and the liter (base unit of volume)

basic salt

a salt formed in a neutralization reaction between a weak acid and a strong base

benzene ring

equivalent resonance structures representing a 6-carbon ring with alternating C-C double bonds

beta decay

a common mode of radioactive decay in which a nucleus emits beta particles

beta particle

a high speed electron, specifically an electron of nuclear origin

binding energy

the amount of energy that holds a nucleus together and also the amount of energy required to decompose a nucleus into its component nucleons

biochemistry

the study of the structure and properties of molecules in living organisms

black body radiation

the energy that would be emitted from an ideal black body.

boiling point elevation

the difference in the boiling points of the pure solvent and the solution

bond energy

the energy required to break a given chemical bond

bond length

the distance between the nuclei of the two atoms connected by a bond

Boyle's law

describes the relationship between the pressure and volume of a gas

Brønsted-Lowry acid

a substance that donates a proton (H⁺)

Brønsted-Lowry base

a substance that accepts a proton (H⁺)

buffer

a solution of a weak acid and its conjugate base or a weak base and its conjugate acid that resists changes in pH when an acid or base is added to it

26.3 C

carbohydrate

molecule that contains carbon, hydrogen, and oxygen and has the general formula $C_x(H_2O)_y$

carbonyl group

a carbon atom double bonded to an oxygen atom

catalyst

a substance that speeds up the rate of the reaction without itself being consumed by the reaction

cathode

the electrode at which reduction occurs

cathode ray tube

a small glass tube with a cathode (a negatively charged metal plate) and an anode (a positively charged metal plate) at opposite ends

cation

a positive ion

chain reaction

a multi-stage nuclear reaction that sustains itself in a series of fissions in which the release of neutrons from the splitting of one atom leads to the splitting of others

Charles's law

describes the relationship between the volume and temperature of a gas

chemical change

change that occurs when one substance is turned into another substance

chemical kinetics

the study of rates of chemical reactions and how factors affect rates of reactions

chemical nomenclature

the systematic procedure for naming chemical compounds

chemical potential energy

energy stored in the atoms, molecules, and chemical bonds that make up matter

chemical property

property that can be observed only when a substance is changed into a new substance

chemical reaction

the process in which one or more substances are changed into one or more new substances

chemistry

the scientific study of matter and the changes that it undergoes

chromatography

any of various techniques for the separation of complex mixtures that rely on the differential affinities of substances for a mobile solvent and a stationary medium through which they pass

coefficient

a whole number that appears in front of a formula in a balanced chemical equation

colligative property

a property that is due only to the number of particles in solution and not related to the chemical properties of the solute

collision frequency

the total number of collisions per second

collision theory

explains why reactions occur at this particle level between atoms, ions, and/or molecules and enables prediction about what conditions are necessary for a successful reaction to take place

colloid

type of mixture in which the size of the particles is between 1×10^3 pm and 1×10^6 pm

column chromatography

a method of chromatography that uses a vertical column filled with absorbent material as the medium through which the mixture is separated

combined gas law

combines Boyle's, Charles's, and Gay-Lussac's laws and describes the relationship between the temperature, pressure, and volume of a gas

combustion

a group of chemical reactants in which the reactants are fuel and oxygen gas

combustion reaction

a reaction in which oxygen reacts with another substance to produce carbon dioxide and water

compound

a pure substance that is made up of more than one type of atom

concentrated

a solution in which there is a large amount of solute in a given amount of solvent

concentration

the measure of how much of a given substance is mixed with another substance

condensation

the process whereby a gas or vapor is changed to a liquid

conductor

a substance that can transmit heat and/or electricity

conjugate acid

the substance that results when a base gains (or accepts) a proton

conjugate base

the substance that results when an acid loses (or donates) a proton

control rod

made of chemical elements capable of absorbing many neutrons, it is used to control the rate of a fission chain reaction in a nuclear reactor

controlled experiment

an experiment that compares the results of an experimental sample to a control sample, where the control sample is identical to the experimental sample in all ways except for the one variable being tested

conversion factor

a factor used to convert one unit of measurement into another unit

coordinate covalent bonds

a type of covalent bond when the two shared electrons of a covalent bond are both donated by the same atom

core electrons

the electrons that are not in the outermost energy level of an atom

covalent bond

a type of chemical bond where two atoms are connected to each other by the sharing of two or more electrons in overlapped orbitals

crest

highest point in a wave pattern (peak of a hill)

critical mass

the smallest mass of a fissionable material that will sustain a nuclear chain reaction at a constant level

critical pressure

the pressure required to liquefy a gas at its critical temperature

critical temperature

the highest temperature at which it is possible to liquefy the substance by increasing pressure

cubic meter

the SI unit of volume

26.4 D

dalton

used to express atomic and molecular masses, it is the approximate mass of a hydrogen atom, a proton, or a neutron and is one-twelfth of the mass of an unbound carbon-12 atom at rest; it is equivalent to the atomic mass unit

Dalton's atomic theory

the first scientific theory to relate chemical changes to the structure, properties, and behavior of the atom

Dalton's law of partial pressures

states that for a mixture of gases in a container, the total pressure exerted is the sum of the pressures that each gas would exert if it were alone

decomposition reaction

a reaction in which one reactant breaks down to form two or more products

delocalized electrons

electrons that are free to move between the bond (in multiple bonding)

derived units

units that are defined in terms of other SI base units

diatomic molecule

a molecule containing exactly two atoms

diffraction

the bending of waves around a barrier

diffusion

the movement of particles from areas of higher concentration to areas of lower concentration

dilute

a solution in which there is a small amount of solute in a given amount of solvent

dimensional analysis

a technique that involves the study of the dimensions (units) of physical quantities

dipeptide

two amino acids joined together

distillation

the evaporation and subsequent collection of a liquid by condensation as a means of purification

DNA (deoxyribonucleic acid)

DNA is a polynucleotide that carries our genetic coding; its function is to direct the body in the synthesis of proteins

double bond

a bond in which two pairs of electrons are shared

double replacement reaction

a reaction in which two reactants form products by having the cations exchange places

ductile

can be drawn out into thin wires

dynamic equilibrium

a state of equilibrium where change is still occurring on a molecular level even though the macroscopic properties remain constant; occurs when the rate of the forward reaction is equal to the rate of the reverse reaction

26.5 E

effective collision

a collision that results in a reaction

effective nuclear charge

the net charge experienced by a specific electron within an atom

electric current

flow of electric charge

electrochemical cell

an arrangement of electrodes and ionic solutions in which a spontaneous redox reaction is used to produce a flow of electrons in an external circuit

electrolysis

a chemical reaction brought about by an electric current

electrolyte

a solution that contains ions and is capable of conducting an electric current

electromagnetic spectrum

a list of all the possible types of light in order of decreasing frequency, increasing wavelength, or decreasing energy; spectrum includes gamma rays, X-rays, UV rays, visible light, IR radiation, microwaves, and radio waves

electron

a negatively charged subatomic particle

electron affinity

the energy released when an electron is added to a gaseous atom or ion

electron configuration code

a code that represents the arrangement of electrons of an atom

electron promotion

moving an electron from a lower sub-energy level to a higher sub-energy level within an energy level

electronegativity

the ability of an atom in a molecule to attract shared electrons

electronic geometry

the geometric arrangement of orbitals containing the shared and unshared electron pairs surrounding the central atom of a molecule or polyatomic ion

electroplating

a process in which electrolysis is used as a means of coating an object with a layer of metal

electrostatic attraction

the force of attraction between opposite electric charges

element

a pure substance that is made up of only one type of atom

elementary step

a single, simple step in a multi-step reaction involving one or two particles

emission spectrum

the unique pattern of electromagnetic radiation frequencies obtained when an element is subjected to specific excitation

empirical formula

a formula that gives the simplest whole number ratio of atoms of each element present in the compound

endothermic reaction

reaction that has a potential energy difference between the products and reactants that is positive

endpoint

the point in the titration where the indicator changes color

energy

is the ability to do work or cause change

energy levels

possible orbits an electron can have in the electron cloud of an atom

enthalpy

amount of energy a system or substance contains

enthalpy of formation

the heat required to form one mole of a substance from its elements at standard temperature and pressure

entropy

a measure of the disorder of a system

enzyme

a subset of proteins that function to speed up a chemical reaction

equilibrium

state where the macroscopic properties of a system do not change over time

equilibrium constant (K)

a mathematical ratio that shows the concentrations of the products divided by concentration of the reactants

equilibrium vapor pressure

the pressure that is exerted, at a given temperature, by the vapor of a solid or liquid in equilibrium with the vapor

equivalence point

the point in the titration where the number of moles of acid equals the number of moles of base

ester

an organic compound with the general formula $\text{RCO}_2\text{R}'$, where R and R' are alkyl groups

ether

an organic compound that contains an oxygen atom bonded to two alkyl groups

evaporation

the escape of molecules from a liquid into the gaseous state at a temperature below the boiling point

excess reactant

any reactant present in an amount that is more than enough to react with the limiting reactant

exothermic reactions

reaction that has a potential energy difference between the products and reactants that is negative

experiment

a controlled method of testing a hypothesis

extrapolation

the process of creating data points beyond the end of a line graph, using the basic shape of the curve as a guide

26.6 F

fatty acid

a carboxylic acid having anywhere from four to thirty-six carbon atoms

fissile

a substance capable of sustaining a chain reaction of nuclear fission

fission

a nuclear reaction in which a heavy nucleus splits into two or more smaller fragments, releasing large amounts of energy

fissionable

a material capable of undergoing fission

formula mass

the sum of the atomic masses of the atoms in a formula

formula unit

one unit of the empirical formula for an ionic compound

fractional distillation

a special type of distillation used to separate a mixture of liquids using their differences in boiling points

freezing

the phase change from liquid to solid

freezing point

the temperature at which a liquid changes to a solid

freezing point depression

the difference in the freezing points of the solution from the pure solvent

frequency (f)

for a wave, the frequency refers the number of waves passing a specific reference point per unit time; in this text, frequency is symbolized by f , but in other text, frequency may be symbolized by λ

functional group

an atom or a group of atoms that replaces hydrogen in an organic compound and is responsible for the characteristic properties of the compound

fusion

depending on the context, fusion could mean the change of a liquid to a solid or a nuclear reaction in which two or more smaller nuclei combine to form a single nucleus

26.7 G

gamma ray

a very high energy form of electromagnetic radiation, emitted from the nucleus

gas chromatography

method, a mixture of liquids are vaporized and passed through a long tube of solid absorbent material

Gay-Lussac's law

describes the relationship between temperature and pressure of a gas

Geiger counter

an instrument used to detect radiation, usually alpha and beta radiation, although some models can also detect gamma radiation

Gibbs free energy

the maximum energy available to do useful work

Graham's law

states that under the same conditions of temperature and pressure, gases diffuse at a rate inversely proportional to the square root of the molecular masses

graph

a pictorial representation of the relationship between variables on a coordinate system

gravimetric analysis

the process for separating and identifying ions by selective precipitation and filtration

group (family)

a vertical column in the periodic table

26.8 H

half-life

the time interval required for a quantity of material to decay to half its original value

halogens

Group 7A of the periodic table

heat

the flow of thermal energy from a warmer object to a cooler object

heat content

the total of all forms of energy for a substance

heat of condensation

the quantity of heat released when a unit mass of a vapor condenses to liquid at constant temperature

heat of fusion

the quantity of heat released when a unit mass of liquid freezes to a solid at a constant temperature

heat of vaporization

the quantity of heat required to vaporize a unit mass of liquid at constant temperature

Heisenberg uncertainty principle

it is impossible to know both the precise location and the precise velocity of an electron at the same time

Henry's law

states that at a given temperature, the solubility of a gas in a liquid is proportional to the partial pressure of the gas above the liquid

hertz (Hz)

the SI unit used to measure frequency; one hertz is equivalent to 1 cycle per second

Hess's Law

if multiple reactions are combined, the enthalpy (ΔH) of the combined reaction is equal to the sum of all the individual enthalpies

heterogeneous mixture

a mixture that consists of visibly different substances

homogeneous mixture

a mixture that is uniform throughout

Hund's rule

a rule that states that no electrons are paired in a given orbital until all the orbitals of the same sub-level have received at least one electron

hydration

the process of water molecules attaching to ions

hydrocarbon

an organic substance consisting of only hydrogen and carbon

hydrogen bond

a type of strong polar attraction between a hydrogen atom in one molecule and a highly electronegative atom, such as N, O, or F, in another molecule.

hydronium ion

a positively charged ion consisting of three hydrogen atoms and one oxygen atom (H_3O^+)

hydroxyl group

an oxygen atom bound covalently with a hydrogen atom

hypothesis

a tentative explanation that can be tested by further investigation

26.9 |

ideal gas

a gas that follows the universal gas law and satisfies the two assumptions that molecules are points that do not take up any space and that there are no attractions between molecules; this is generally true for gases at low pressure and high temperature

immiscible

liquids that do not have the ability to dissolve in each other

incompressible

describes the inability of molecules in a substance to be compacted (pushed closer together)

indicator

substance used to determine the relative acidity or basicity of a solution, generally through a very distinct color change

ionizing power

ability of radiation to damage molecules

insoluble

unable to dissolve

instantaneous rate

the rate of change at a particular time interval

internal energy

total energy contained in a thermodynamic system; often called enthalpy

interference

the addition of two or more waves that result in a new wave pattern

International System of Units (Le Système International d' Unites)

the internationally agreed upon standard metric system, also abbreviated as the SI system (derived from the French name)

interpolation

the process of estimating values between measured values

ion

an atom with a positive or negative charge

ion product constant for water, K_w

the product of the hydronium ion and the hydroxide ion concentrations in the autoionization of water

ionic bond

the electrostatic attraction between ions resulting from the transfer of electrons from one of the bonding atoms to the other

ionic conduction

movement of ions through solution

ionic equation

chemical equation written such that the actual free ions are shown for each species in aqueous form

ionization energy

the energy required to remove the most loosely held electron from a gaseous atom or ion

irreversible reaction

a reaction that continues to form products until reactants are fully consumed

isotopes

atoms of the same element that have the same number of protons but different numbers of neutrons

26.10 J

joule

the SI unit for energy, equivalent to $1 \frac{\text{kg}\cdot\text{m}^2}{\text{s}^2}$

26.11 K

K_a

the equilibrium constant for the dissociation of a weak acid

K_b

the equilibrium constant for the dissociation of a weak base

Kelvin temperature scale

a temperature scale which has its zero at absolute zero

ketone

an organic compound that has a carbonyl group linked to two alkyl groups

kilogram

the SI unit of mass

kinetic energy

energy associated with motion

kinetic molecular theory

the foundation for the collision theory on the atomic level, the theory considers the collisions between particles to be elastic in nature

26.12 L

lanthanide series

elements with atomic numbers 57 – 70

lattice structure

a systematic, symmetrical network of atoms forming an ionic solid.

law of conservation of energy

states that energy cannot be created or destroyed, it can only be changed from one form to another

law of conservation of matter and energy

states that the total amount of mass and energy in the universe is conserved (does not change)

law of constant composition

law that states that the ratio by mass of the elements in a chemical compound is always the same, regardless of the source of the compound

law of definite proportions

states that in a given chemical substance, the elements are always combined in the same proportions by mass

law of multiple proportions

states that when two elements react to form more than one substance and the same amount of one element is used in each substance, then the ratio of the masses used of the other element will be in small whole numbers

Le Châtelier's Principle

applying a stress to a system at equilibrium causes a shift in the equilibrium position that partially counteracts the stress

length

the measurement of anything from end to end

Lewis acid

a substance that accepts a pair of electrons from another substance

Lewis base

a substance that donates a pair of electrons to a substance

Lewis dot diagram

a diagram that shows valence electrons as dots around the symbol of an element

limiting reactant

the reactant that determines the maximum amount of product that can be formed in a chemical reaction

lipids

fats and oils (triglycerides) produced for the purpose of storing energy

London dispersion forces

the electrostatic attractions of molecule or atoms for nearby molecules or atoms caused by the temporary unsymmetrical distribution of electrons in electron clouds

26.13 M

macroscopic properties

properties that describe the system as a whole and can be observed and measured without determining the properties of individual molecules

magnetic quantum number

a number that describes the orientation in space of a particular orbital

malleable

property of being able to be hammered or rolled into sheets

manometer

a liquid column pressure-measuring device

mass

a measure of the amount of matter in an object

mass defect

the difference between the sum of the masses of the nuclear components and the mass of the corresponding nucleus

mass number

the total number of protons and neutrons in the nucleus of an atom

mass percent

the number of grams of the solute in the number of grams of solution

matter

anything that has mass and volume

melting

the phase change from solid to liquid

melting point

the temperature at which a substance changes from the solid phase to the liquid phase

metallic bond

the attractive force that binds metal atoms together

metallic conduction

movement of electrons through a piece of metal

meter

the SI unit of length

metric system

an international decimal-based system of measurement

miscible

liquids that have the ability to dissolve in each other

model

a descriptive, graphic, or three-dimensional representation of a hypothesis or theory used to help enhance understanding

moderator

a medium that reduces the velocity of fast neutrons

molality

the number of moles of solute per kilograms of solvent

molar mass

the mass in grams of one mole of a substance

molar volume

the volume occupied by one mole of a substance in the form of a solid, liquid, or gas

molarity

the number of moles of solute per liter of solution

mole

an Avogadro's number of objects; 1.00 mole of carbon-12 atoms has a mass of 12.0 grams and contains 6.02×10^{23} atoms

mole ratio

a quantitative relationship between two components of a chemical reaction, determined by the coefficients in the balanced equation

molecular formula

a formula indicating the actual number of each kind of atom contained in a molecule

molecular geometry

the specific three-dimensional arrangement of atoms in a molecule

molecular mass

the mass of a molecule found by adding the atomic masses of the atoms comprising the molecule

molecule

the smallest particle of a compound

multi-step reaction

a reaction that occurs in more than one step

26.14 N**natural indicator**

an indicator that is a naturally occurring substance

natural radioactivity

the radioactivity that occurs naturally, as opposed to induced radioactivity; also known as spontaneous fission

net ionic equation

the overall equation that results when spectator ions are removed from the ionic equation

nuclear symbol

contains the symbol for the element and the numbers that relate to the number of protons and neutrons in that particular nucleus

nucleon

a collective name for neutrons and protons

neutral salt

a salt formed in a neutralization reaction between a strong acid and a strong base or a weak acid and a weak base

neutralization

a reaction between an acid and a base that produces water and a salt

neutron

a subatomic particle with no charge

noble gases

Group 8A of the periodic table

non-electrolyte

a solution that does not contain ions and is not capable of conducting an electric current

non-spontaneous event (or reaction)

an unfavorable reaction that requires an external energy source in order for the reaction to take place

nuclear charge

the number of protons in the nucleus

nucleus

the center of the atom

26.15 O

observation

using the senses to gather information about the natural world

octet rule

an expression of the tendency for atoms to gain or lose the appropriate number of electrons so that the resulting ion has either completely filled or completely empty outer energy levels

orbital hybridization

orbitals involved in covalent bonding in an atom are hybridized so that they are identical in properties, and those properties are intermediate to the properties of the original orbitals

orbital representation

a method that uses circles or lines to represent the orbitals where electrons in an atom are located

organic acid

an organic compound containing one or more carboxyl groups

oxidation

a loss of electrons in an atom or an increase in the oxidation state of an atom

oxidation number

in ionic compounds, it is equal to the ionic charge; in covalent compounds, it is the charge assigned to the atom in accordance with a set of rules

oxidizing agent

a substance that gains electrons in a chemical reaction or undergoes an increase in its oxidation state

26.16 P**paper chromatography**

a method of chromatography that uses paper as the medium upon which the mixture to be separated is applied

partial pressure

the pressure that one component of a mixture of gases would exert if it were alone in a container

parts per million (ppm)

the mass of solute per mass of solution multiplied by 1 million

pascal

the SI unit of pressure, equivalent to 1 Newtons/meter²

Pauli exclusion principle

no two subatomic particles can be in states characterized by the same set of quantum numbers

penetration power

ability of radiation to pass through matter

percent composition

the proportion of an element present in a compound, found by dividing the mass of the element by the mass of the whole compound and multiplying by 100%

percent error

a measurement of how far an experimental value is from the accepted value

percent yield

the ratio of the actual yield to the theoretical yield expressed as a percentage

period

a horizontal row in the periodic table

periodic law

states that the properties of the elements recur periodically as their atomic numbers increase

periodic table

a tabular arrangement of the chemical elements according to atomic number

pH

the negative logarithm of the hydrogen ion concentration

phase

any of the forms or states (solid, liquid, gas, or plasma) in which matter can exist

phlogiston

the “fire substance” from a former theory of combustion

phospholipid

a combination of fatty acids, glycerol and a phosphate group joined together

photoelectric effect

a phenomenon in which electrons are emitted from the surface of a material after the absorption of energy

photon

a particle of light

physical change

change that does not alter the identity of a substance

physical property

property that can be observed without changing the identity of the substance

pi bond

a covalent bond in which **p** orbitals share an electron pair occupying the space above and below the line joining the atoms

pOH

the negative logarithm of the hydroxide ion concentration

polar covalent bonds

covalent bonds in which the shared bonding electrons are not shared equally, resulting in a dipole on the molecule

polyatomic ion

a group of covalently bound atoms that carry an overall charge, which interacts with other molecules as a single unit

polymer

a large organic molecule that contains hundreds or even thousands of atoms

polypeptide

many amino acids combined together

potential energy

stored energy

potential energy diagram

potential energy diagram in the study of kinetics shows how the potential energy changes during reactions from reactants to products

precipitate

the solid that is formed as a result of a precipitation reaction

precipitation reaction

a reaction in which soluble ions in separate solutions are mixed together to form an insoluble compound that settles out of the solution

precision

reflects how close the values in a set of measurements are to each other

principal quantum number

a number that indicates the main energy level of an electron in an atom

problem

the purpose for a scientific investigation

products

materials present at the end of a reaction

protein

polymer that is an amino acid

proton

a positively charged subatomic particle

26.17 Q**qualitative observation**

observation that yields descriptive, nonnumerical results

quantitative observation

observation that yields meaningful, numerical results

quantum (singular form of quanta)

small unit of energy

quantum mechanics

the branch of physics that deals with the behavior of matter at the atomic and subatomic level

quantum numbers

four special numbers that completely describe the state of an electron in an atom

quantum theory

the theory that energy can only exist in discrete amounts (quanta)

quark

physical particles that form one of the two basic constituents of matter; various species of quarks combine in specific ways to form protons and neutrons, in each case taking exactly three quarks to make the composite particle

26.18 R

rate-determining step

the slowest step in a multi-step reaction

rate of reaction

the measure at which the products are formed over a time interval or the rate at which the reactants are consumed over a time interval

reactants

the starting materials in a reaction

reaction mechanism

the series of elementary reactions describing what occurs in a multi-step reaction

real gas

a gas that does not follow the ideal gas laws, which is generally the case for gases at high pressures or low temperatures

redox reaction

short for oxidation-reduction reaction, a chemical reaction that involves electrons being transferred from one substance to another

reducing agent

the substance in a redox reaction that loses electrons or increases its oxidation state

reduction

the gain of electrons or decrease in oxidation state in a chemical reaction

resonance

a condition occurring when more than one valid Lewis structure can be written for a particular molecule; the actual electronic structure is not represented by any one of the Lewis structures but by the average of all of them

retention factor

the ratio of the distance a substance moves up the stationary phase to the distance the solvent have moved

reversible reaction

a reaction that can also proceed in the reverse direction

26.19 S**salt bridge**

a U-shaped tube containing an electrolyte that connects two half-cells in an electrochemical cell

saturated compound

an organic molecule containing only single bonds

saturated solution

a solution in which a given amount of solvent has dissolved the absolute maximum amount solute at that temperature

scientific law

a statement that summarizes the results of many observations and experiments

scientific method

a method of investigation involving experimentation and observation to acquire new knowledge, solve problems, and answer questions

scientific notation

a shorthand method of writing very large and very small numbers by expressing them as a product of a decimal number between 1 and 10 multiplied by an integral power of 10

second

the SI unit for time

shielding effect

the effect where the inner electrons help “shield” the outer electrons and the nucleus from each other

sigma bond

a covalent bond in which the electron pair is shared in an area centered on a line running between the atoms

significant figure

includes all of the digits that can be known with certainty in a measurement plus an estimated last digit

single replacement reaction

a reaction in which an element reacts with a compound to form products

slope

the ratio of the change in one variable with respect to the other variable

solubility

the maximum amount of a substance that will dissolve in a given amount of solvent at a specific temperature

solubility product constant, K_{sp}

equilibrium constant for a slightly soluble salt

soluble

able to dissolve

solute

the substance in a solution present in the least amount

solution

a homogeneous mixture of substances

solvent

the substance in a solution present in the greatest amount

specific heat

the amount of energy necessary to raise 1.00 gram of a substance by 1.00°C

spectator ions

the ions in the total ionic equation that appear in the same form on both sides of the equation indicating they do not participate in the overall reaction

spin quantum number

a number that indicates the orientation of the angular momentum of an electron in an atom

spontaneous event (or reaction)

a change that occurs without outside inference

standard solution

a solution whose concentration is known exactly and is used to find the exact concentration of the titrant

steroid

compound where four carbon rings are bounded together with branches and functional groups bounded to the rings

stoichiometry

the calculation of quantitative relationships of the reactants and products in a balanced chemical equation

strong acid

acid that undergoes 100% dissociation in water

strong base

base that undergoes 100% dissociation in water

strong nuclear force

the strong interaction that is responsible for binding the protons and neutrons in the atomic nuclei together

structural isomers

molecules with the same formula but different structures

subatomic particles

particles that are smaller than the atom

subscript

part of the chemical formula that indicates the number of atoms of the preceding element

surroundings

everything but the reactants and products in the reaction

suspension

type of mixture in which the particles settle to the bottom of the container and can be separated by filtration

synthetic indicator

an indicator that is synthesized in the laboratory

synthesis reaction

a reaction in which two or more reactants combine to make one product

system

the reactants and products in the reaction

26.20 T**temperature**

the average kinetic energy of the particles that make up a material

theoretical yield

the amount of product that could be formed from a chemical reaction based on the balanced chemical equation

theory

an explanation that summarizes a hypothesis or a set of hypotheses and has been supported with repeated testing

thin-layer chromatography

a method of chromatography that uses silica gel or a similar inert material on a glass microscope slide or plastic sheet to which the mixture is applied

threshold energy

the minimum amount of energy necessary for a reaction to take place

titrant

the solution of known concentration used in a titration

titration

the process in which a known concentration of base (or acid) is added to a solution of acid (or base) of unknown concentration

titration curve

a graph of the pH versus the volume of titrant added

torr

unit of pressure, equivalent to 1 mm of Hg

transition elements

Groups 3 – 12 of the periodic table

triple bond

a bond in which three pairs of electrons are shared

trough

lowest point in a wave pattern (low point of a valley)

Tyndall effect

the scattering of light by particles

26.21 U

universal gas law

relates the volume of a gas with pressure, temperature, and number of moles of gas; written mathematically as $PV = nRT$

universal gas law constant (R)

constant equal to $\frac{PV}{nT}$, where the pressure, volume, moles, and temperature of the gas are represented by P , V , n , and T , respectively; the value and units of R depend on the units of P and V , and two commonly used values of R are $0.08206 \text{ L atm K}^{-1} \text{ mol}^{-1}$ and $8.314 \text{ J K}^{-1} \text{ mol}^{-1}$

unsaturated compound

an organic molecule containing double or triple bonds

unsaturated solution

a solution in which a given amount of solvent has dissolved less than the absolute maximum amount solute at that temperature

unshared electron pair

an unshared electron pair, also known as a non-bonding pair of electrons or as a lone pair of electrons, is found in a filled valence orbital that is not used in the formation of a covalent bond

26.22 V**valence electrons**

the electrons in the outermost principal quantum level of an atom

valence shell

the outermost energy level of an atom

van't Hoff factor

the number of particles that the solute will dissociate into upon mixing with the solvent

vapor

the gaseous phase of a substance that exists even though the temperature is below the boiling point of the substance

vapor pressure

pressure of the vapor in the space above the liquid

velocity

distance traveled in one second.

voltage

the potential difference between two points in an electric circuit

volume

the amount of space an object occupies

VSEPR (valence shell electron pair repulsion) theory

a theory whose main postulate is that the structure around a given atom in a molecule is determined by minimizing electron-pair repulsion

26.23 W

wavelength (λ)

the length of a single wave from peak to peak (crest to crest or trough to trough)

wave-particle duality

the concept that all matter and energy exhibit both wave-like and particle-like properties

weak acid

acid that does not completely dissociate in water

weak base

base that does not completely dissociate in water

weight

the force of attraction between the object and the earth (or whatever large, gravity-producing body the object is located on)

work

force (any push or pull) applied over a distance

26.24 X

26.25 Y

26.26 Z