

ck-12

flexbook
next generation textbooks

CK-12 Basic Geometry

Concept Collection



CK-12 Basic Geometry Concepts

Dan Greenberg
Lori Jordan
Andrew Gloag
Victor Cifarelli
Jim Sconyers
Bill Zahner

Say Thanks to the Authors

Click <http://www.ck12.org/saythanks>

(No sign in required)

To access a customizable version of this book, as well as other interactive content, visit www.ck12.org

CK-12 Foundation is a non-profit organization with a mission to reduce the cost of textbook materials for the K-12 market both in the U.S. and worldwide. Using an open-content, web-based collaborative model termed the **FlexBook®**, CK-12 intends to pioneer the generation and distribution of high-quality educational content that will serve both as core text as well as provide an adaptive environment for learning, powered through the **FlexBook Platform®**.

Copyright © 2013 CK-12 Foundation, www.ck12.org

The names “CK-12” and “CK12” and associated logos and the terms “**FlexBook®**” and “**FlexBook Platform®**” (collectively “CK-12 Marks”) are trademarks and service marks of CK-12 Foundation and are protected by federal, state, and international laws.

Any form of reproduction of this book in any format or medium, in whole or in sections must include the referral attribution link <http://www.ck12.org/saythanks> (placed in a visible location) in addition to the following terms.

Except as otherwise noted, all CK-12 Content (including CK-12 Curriculum Material) is made available to Users in accordance with the Creative Commons Attribution-Non-Commercial 3.0 Unported (CC BY-NC 3.0) License (<http://creativecommons.org/licenses/by-nc/3.0/>), as amended and updated by Creative Commons from time to time (the “CC License”), which is incorporated herein by this reference.

Complete terms can be found at <http://www.ck12.org/terms>.

Printed: September 26, 2013

flexbook
next generation textbooks



AUTHORS

Dan Greenberg
Lori Jordan
Andrew Gloag
Victor Cifarelli
Jim Sconyers
Bill Zahner

EDITOR

Annamaria Farbizio

Contents

1	Basics of Geometry	1
1.1	Basic Geometric Definitions	2
1.2	Distance Between Two Points	10
1.3	Congruent Angles and Angle Bisectors	16
1.4	Midpoints and Segment Bisectors	21
1.5	Angle Measurement	26
1.6	Angle Classification	33
1.7	Complementary Angles	37
1.8	Supplementary Angles	41
1.9	Linear Pairs	44
1.10	Vertical Angles	47
1.11	Triangle Classification	51
1.12	Polygon Classification	57
2	Reasoning and Proof	64
2.1	Inductive Reasoning from Patterns	65
2.2	Deductive Reasoning	70
2.3	If-Then Statements	74
2.4	Converse, Inverse, and Contrapositive	77
2.5	Conjectures and Counterexamples	81
2.6	Properties of Equality and Congruence	84
2.7	Two-Column Proofs	88
3	Parallel and Perpendicular Lines	100
3.1	Parallel and Skew Lines	101
3.2	Perpendicular Lines	107
3.3	Corresponding Angles	116
3.4	Alternate Interior Angles	122
3.5	Alternate Exterior Angles	128
3.6	Same Side Interior Angles	133
3.7	Slope in the Coordinate Plane	139
3.8	Parallel Lines in the Coordinate Plane	145
3.9	Perpendicular Lines in the Coordinate Plane	150
3.10	Distance Formula in the Coordinate Plane	155
3.11	Distance Between Parallel Lines	158
4	Triangles and Congruence	164
4.1	Triangle Sum Theorem	165
4.2	Exterior Angles Theorems	171
4.3	Congruent Triangles	178
4.4	Congruence Statements	183
4.5	Third Angle Theorem	187

4.6	SSS Triangle Congruence	192
4.7	SAS Triangle Congruence	200
4.8	ASA and AAS Triangle Congruence	207
4.9	HL Triangle Congruence	214
4.10	Isosceles Triangles	219
4.11	Equilateral Triangles	225
5	Triangle Relationships	233
5.1	Midsegment Theorem	234
5.2	Perpendicular Bisectors	241
5.3	Angle Bisectors in Triangles	248
5.4	Medians	254
5.5	Altitudes	260
5.6	Comparing Angles and Sides in Triangles	266
5.7	Triangle Inequality Theorem	272
5.8	Indirect Proof in Algebra and Geometry	275
6	Polygons and Quadrilaterals	279
6.1	Interior Angles in Convex Polygons	280
6.2	Exterior Angles in Convex Polygons	286
6.3	Parallelograms	289
6.4	Quadrilaterals that are Parallelograms	297
6.5	Parallelogram Classification	306
6.6	Trapezoids	313
6.7	Kites	319
6.8	Quadrilateral Classification	326
7	Similarity	331
7.1	Forms of Ratios	332
7.2	Proportion Properties	336
7.3	Similar Polygons and Scale Factors	341
7.4	AA Similarity	347
7.5	Indirect Measurement	353
7.6	SSS Similarity	357
7.7	SAS Similarity	362
7.8	Triangle Proportionality	369
7.9	Parallel Lines and Transversals	374
7.10	Proportions with Angle Bisectors	381
7.11	Dilation	390
7.12	Dilation in the Coordinate Plane	396
7.13	Self-Similarity	400
8	Right Triangle Trigonometry	404
8.1	Expressions with Radicals	405
8.2	Pythagorean Theorem and Pythagorean Triples	408
8.3	Applications of the Pythagorean Theorem	415
8.4	Inscribed Similar Triangles	421
8.5	45-45-90 Right Triangles	429
8.6	30-60-90 Right Triangles	434
8.7	Sine, Cosine, Tangent	439
8.8	Trigonometric Ratios with a Calculator	444
8.9	Trigonometry Word Problems	448

8.10	Inverse Trigonometric Ratios	453
9	Circles	460
9.1	Parts of Circles	461
9.2	Tangent Lines	466
9.3	Arcs in Circles	474
9.4	Chords in Circles	482
9.5	Inscribed Angles in Circles	491
9.6	Inscribed Quadrilaterals in Circles	498
9.7	Angles On and Inside a Circle	503
9.8	Angles Outside a Circle	509
9.9	Segments from Chords	514
9.10	Segments from Secants	521
9.11	Segments from Secants and Tangents	529
9.12	Circles in the Coordinate Plane	538
10	Perimeter and Area	544
10.1	Area and Perimeter of Rectangles	545
10.2	Area of a Parallelogram	548
10.3	Area and Perimeter of Triangles	553
10.4	Area of Composite Shapes	557
10.5	Area and Perimeter of Trapezoids	563
10.6	Area and Perimeter of Rhombuses and Kites	568
10.7	Area and Perimeter of Similar Polygons	575
10.8	Circumference	579
10.9	Arc Length	583
10.10	Area of a Circle	588
10.11	Area of Sectors and Segments	592
11	Surface Area and Volume	598
11.1	Polyhedrons	599
11.2	Cross-Sections and Nets	605
11.3	Prisms	611
11.4	Cylinders	619
11.5	Pyramids	624
11.6	Cones	631
11.7	Spheres	637
11.8	Composite Solids	642
11.9	Area and Volume of Similar Solids	649
12	Rigid Transformations	654
12.1	Reflection Symmetry	655
12.2	Rotation Symmetry	661
12.3	Geometric Translations	666
12.4	Rotations	672
12.5	Reflections	684
12.6	Composition of Transformations	697
12.7	Tessellations	707
	Back Matter	712

CHAPTER

1**Basics of Geometry****Chapter Outline**

- 1.1 BASIC GEOMETRIC DEFINITIONS**
 - 1.2 DISTANCE BETWEEN TWO POINTS**
 - 1.3 CONGRUENT ANGLES AND ANGLE BISECTORS**
 - 1.4 MIDPOINTS AND SEGMENT BISECTORS**
 - 1.5 ANGLE MEASUREMENT**
 - 1.6 ANGLE CLASSIFICATION**
 - 1.7 COMPLEMENTARY ANGLES**
 - 1.8 SUPPLEMENTARY ANGLES**
 - 1.9 LINEAR PAIRS**
 - 1.10 VERTICAL ANGLES**
 - 1.11 TRIANGLE CLASSIFICATION**
 - 1.12 POLYGON CLASSIFICATION**
-

Introduction

In this chapter, students will learn about the building blocks of geometry. We will start with what the basic terms: point, line and plane. From here, students will learn about segments, midpoints, angles, bisectors, angle relationships, and how to classify polygons.

1.1 Basic Geometric Definitions

Here you'll learn the basic geometric definitions and rules you will need to succeed in geometry.

What if you were given a picture of a figure or object, like a map with cities and roads marked on it? How could you explain that picture geometrically? After completing this Concept, you'll be able to describe such a map using geometric terms.

Watch This



MEDIA

Click image to the left for more content.

CK-12 Basic Geometric Definitions - Guidance

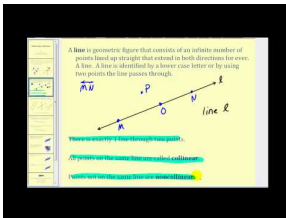

MEDIA

Click image to the left for more content.

James Sousa:Definitions of and Postulates Involving Points, Lines, and Planes

Guidance

A **point** is an exact location in space. It describes a **location**, but has no size. Examples are shown below:



TABLE 1.1:

<i>Label It</i>	<i>Say It</i>
A	point A

A **line** is infinitely many points that extend forever in both directions. Lines have **direction** and **location** and are always straight.



TABLE 1.2:

<i>Label It</i>	<i>Say It</i>
line g	line g
\overleftrightarrow{PQ}	line PQ

A **plane** is infinitely many intersecting lines that extend forever in all directions. Think of a plane as a huge sheet of paper that goes on forever.

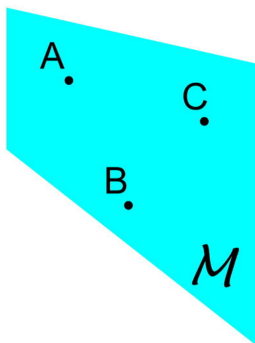

TABLE 1.3:

<i>Label It</i>	<i>Say It</i>
Plane \mathcal{M}	Plane M
Plane ABC	Plane ABC

We can use **point**, **line**, and **plane** to define new terms.

Space is the set of all points extending in *three* dimensions. Think back to the plane. It extended in two dimensions, what we think of as up/down and left/right. If we add a third dimension, one that is perpendicular to the other two, we arrive at three-dimensional space.

Points that lie on the same line are **collinear**. $P, Q, R, S,$ and T are collinear because they are all on line w . If a point U were located above or below line w , it would be **non-collinear**.



Points and/or lines within the same plane are **coplanar**. Lines h and i and points $A, B, C, D, G,$ and K are **coplanar** in Plane j . Line \overleftrightarrow{KF} and point E are **non-coplanar** with Plane j .

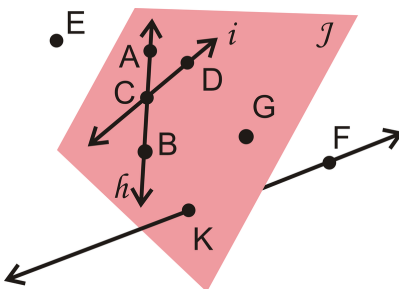

An **endpoint** is a point at the end of a line segment. A **line segment** is a portion of a line with two endpoints. Or, it is a finite part of a line that stops at both ends. Line segments are labeled by their endpoints. Order does not matter.



TABLE 1.4:

<i>Label It</i>	<i>Say It</i>
\overline{AB}	Segment AB
\overline{BA}	Segment BA

A **ray** is a part of a line with one endpoint that extends forever in the direction opposite that endpoint. A ray is labeled by its endpoint and one other point on the ray. For rays, order matters. When labeling, put the endpoint under the side WITHOUT the arrow.



TABLE 1.5:

<i>Label It</i>	<i>Say It</i>
\overrightarrow{CD}	Ray CD
\overleftarrow{DC}	Ray CD

An **intersection** is a point or set of points where lines, planes, segments, or rays cross.

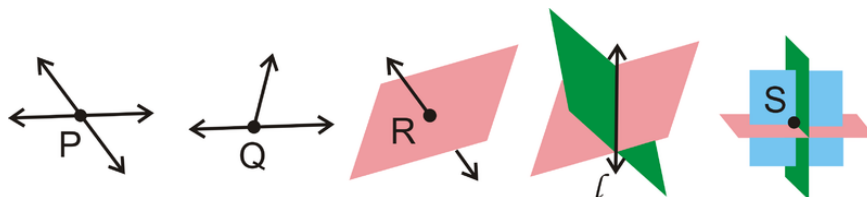

Postulates

A **postulate** is a basic rule of geometry. Postulates are assumed to be true (rather than proven), much like definitions. The following is a list of some basic postulates.

Postulate #1: Given any two distinct points, there is exactly one (straight) line containing those two points.



Postulate #2: Given any three non-collinear points, there is exactly one plane containing those three points.

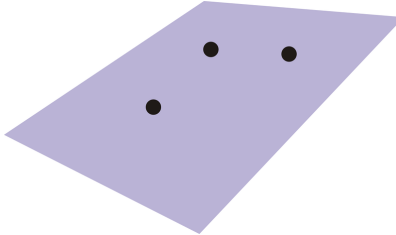

Postulate #3: If a line and a plane share two points, then the entire line lies within the plane.

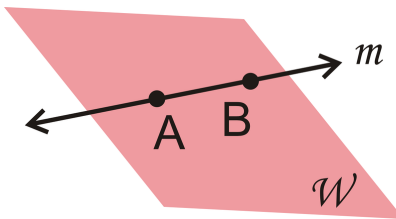

Postulate #4: If two distinct lines intersect, the intersection will be one point.

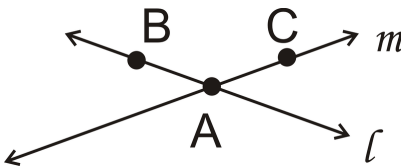

Lines l and m intersect at point A .

Postulate #5: If two distinct planes intersect, the intersection will be a line.

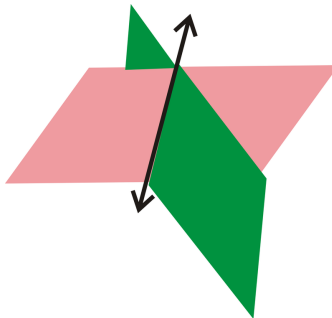

When making geometric drawings, be sure to be clear and label all points and lines.

Example A

What best describes San Diego, California on a globe?

- A. point
- B. line
- C. plane

Answer: A city is usually labeled with a dot, or point, on a globe.

Example B

Use the picture below to answer these questions.

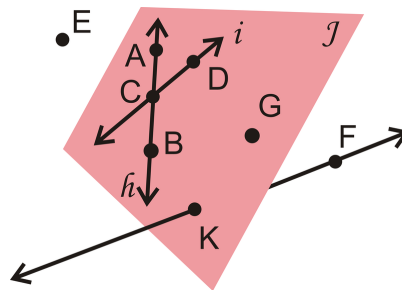

- a) List another way to label Plane j .
- b) List another way to label line h .
- c) Are K and F collinear?
- d) Are E, B and F coplanar?

Answer:

- a) Plane BDG . Any combination of three coplanar points that are not collinear would be correct.
- b) \overleftrightarrow{AB} . Any combination of two of the letters A, B , or C would also work.
- c) Yes
- d) Yes

Example C

What best describes a straight road connecting two cities?

- A. ray
- B. line
- C. segment
- D. plane

Answer: The straight road connects two cities, which are like endpoints. The best term is segment, or C.



MEDIA

Click image to the left for more content.

CK-12 Basic Geometric Definitions E

Guided Practice

1. What best describes the surface of a movie screen?

- A. point
- B. line
- C. plane

2. Answer the following questions about the picture.

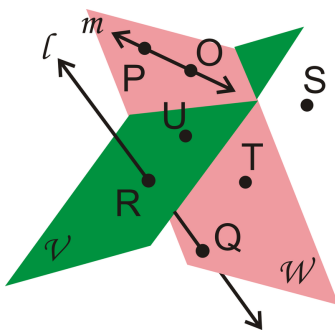

a) Is line l coplanar with Plane \mathcal{V} , Plane \mathcal{W} , both, or neither?

b) Are R and Q collinear?

c) What point belongs to neither Plane \mathcal{V} nor Plane \mathcal{W} ?

d) List three points in Plane \mathcal{W} .

3. Draw and label a figure matching the following description: Line \overleftrightarrow{AB} and ray \overrightarrow{CD} intersect at point C . Then, redraw so that the figure looks different but is still true to the description.

4. Describe the picture below using the geometric terms you have learned.

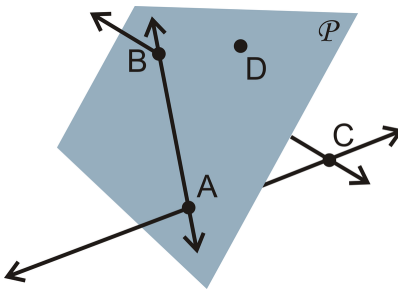

Answers:

1. The surface of a movie screen is most like a plane.

2. a) Neither

- b) Yes
 - c) S
 - d) Any combination of $P, O, T,$ and Q would work.
3. Neither the position of A or B on the line, nor the direction that \overleftrightarrow{CD} points matter.

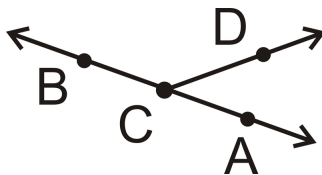

For the second part:

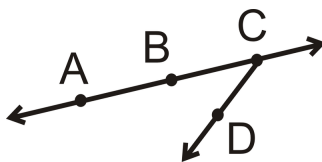

4. \overleftrightarrow{AB} and D are coplanar in Plane \mathcal{P} , while \overleftrightarrow{BC} and \overleftrightarrow{AC} intersect at point C .

Practice

For questions 1-5, draw and label a figure to fit the descriptions.

1. \overleftrightarrow{CD} intersecting \overline{AB} and Plane \mathcal{P} containing \overline{AB} but not \overleftrightarrow{CD} .
2. Three collinear points $A, B,$ and C and B is also collinear with points D and E .
3. $\overleftrightarrow{XY}, \overleftrightarrow{XZ},$ and \overleftrightarrow{XW} such that \overleftrightarrow{XY} and \overleftrightarrow{XZ} are coplanar, but \overleftrightarrow{XW} is not.
4. Two intersecting planes, \mathcal{P} and \mathcal{Q} , with \overline{GH} where G is in plane \mathcal{P} and H is in plane \mathcal{Q} .
5. Four non-collinear points, $I, J, K,$ and L , with line segments connecting all points to each other.
6. Name this line in five ways.

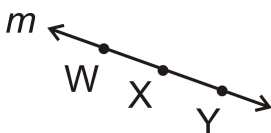

7. Name the geometric figure in three different ways.



8. Name the geometric figure below in two different ways.

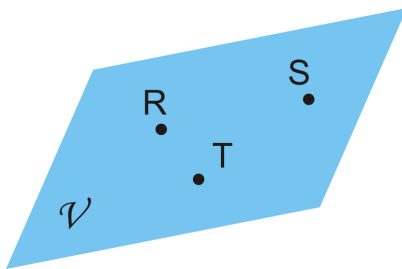

9. What is the best possible geometric model for a soccer field? Explain your answer.
10. List two examples of where you see rays in real life.
11. What type of geometric object is the intersection of a line and a plane? Draw your answer.
12. What is the difference between a postulate and a theorem?

For 13-16, use geometric notation to explain each picture in as much detail as possible.

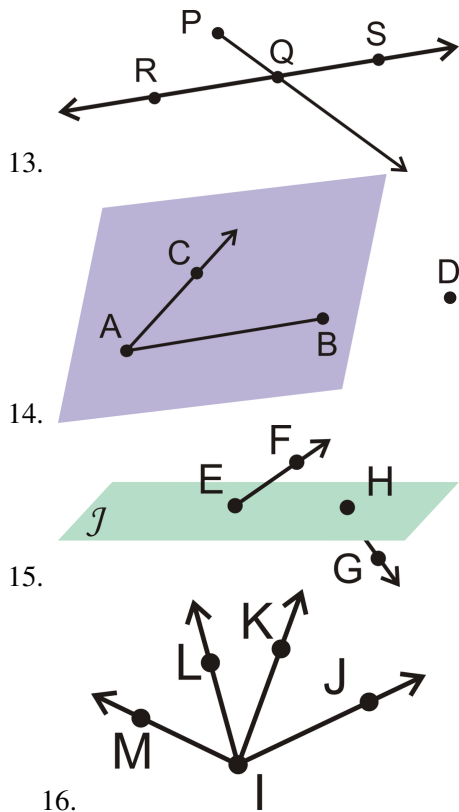

For 17-25, determine if the following statements are true or false.

17. Any two points are collinear.
18. Any three points determine a plane.
19. A line is to two rays with a common endpoint.
20. A line segment is infinitely many points between two endpoints.
21. A point takes up space.
22. A line is one-dimensional.
23. Any four points are coplanar.
24. \overrightarrow{AB} could be read "ray AB " or "ray BA ."
25. \overleftrightarrow{AB} could be read "line AB " or "line BA ."

1.2 Distance Between Two Points

Here you'll learn how to measure the distance between two points on a horizontal or vertical line.

What if you were given the coordinates of two points that form either a vertical or horizontal line? How would you determine how far apart those two points are? After completing this Concept, you'll be able to determine the distance between two such points.

Watch This



MEDIA

Click image to the left for more content.

CK-12 Measuring Distances

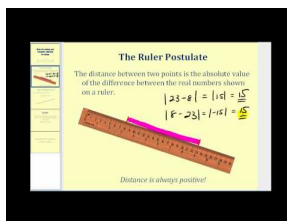

MEDIA

Click image to the left for more content.

James Sousa:Ruler PostulateandSegmentAddition Postulate

Guidance

Distance is the measure of length between two points. To **measure** is to determine how far apart two geometric objects are. The most common way to measure distance is with a ruler. Inch-rulers are usually divided up by eighth-inch (or 0.125 in) segments. Centimeter rulers are divided up by tenth-centimeter (or 0.1 cm) segments. Note that the distance between two points is the absolute value of the difference between the numbers shown on the ruler. This implies that you do not need to start measuring at "0", as long as you subtract the first number from the second.

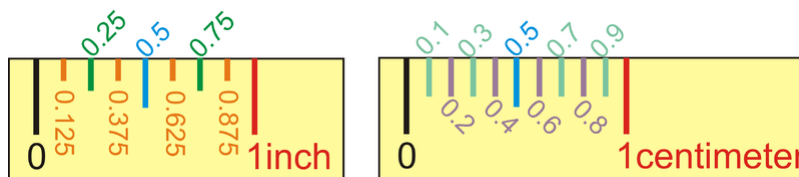

The **segment addition postulate** states that if A , B , and C are collinear and B is between A and C , then $AB + BC = AC$.



You can find the distances between points in the x - y plane if the lines are horizontal or vertical. *If the line is vertical, find the change in the y -coordinates. If the line is horizontal, find the change in the x -coordinates.*

Example A

What is the distance marked on the ruler below? The ruler is in centimeters.

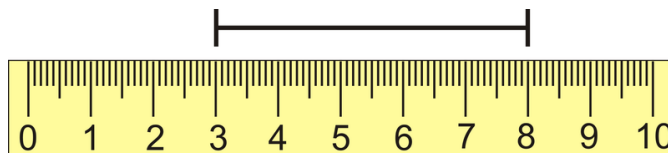

Subtract one endpoint from the other. The line segment spans from 3 cm to 8 cm. $|8 - 3| = |5| = 5$
 The line segment is 5 cm long. Notice that you also could have done $|3 - 8| = |-5| = 5$.

Example B

Make a sketch of \overline{OP} , where Q is between O and P .

Draw \overline{OP} first, then place Q on the segment.



Example C

What is the distance between the two points shown below?

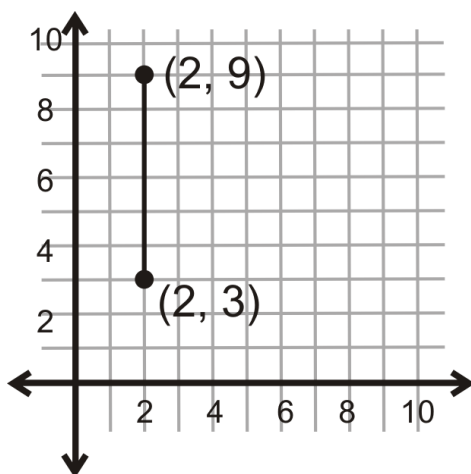

Because this line is vertical, look at the change in the y -coordinates.

$$|9 - 3| = |6| = 6$$

The distance between the two points is 6 units.



MEDIA

Click image to the left for more content.

CK-12 Measuring Distances

Guided Practice

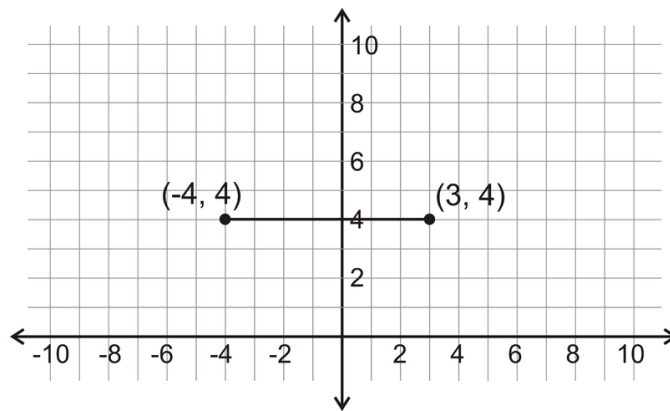
1. Draw \overline{CD} , such that $CD = 3.825$ in.
2. In the picture from Example B, if $OP = 17$ and $QP = 6$, what is OQ ?
3. What is the distance between the two points shown below?

Answers:

1. To draw a line segment, start at "0" and draw a segment to 3.825 in.

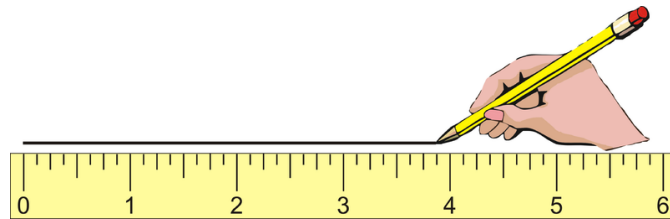

Put points at each end and label.



2. Use the Segment Addition Postulate.

$$OQ + QP = OP$$

$$OQ + 6 = 17$$

$$OQ = 17 - 6$$

$$OQ = 11$$

3. Because this line is horizontal, look at the change in the x -coordinates.

$$|(-4) - 3| = |-7| = 7$$

The distance between the two points is 7 units.

Practice

For 1-4, use the ruler in each picture to determine the length of the line segment.

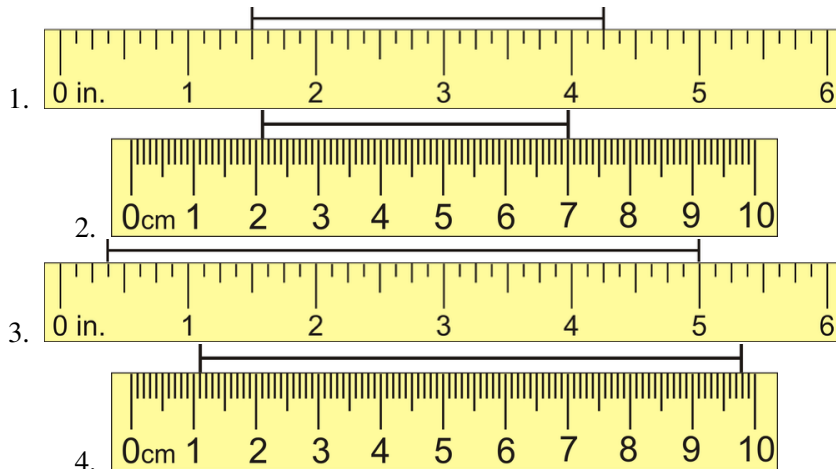

5. Make a sketch of \overline{BT} , with A between B and T .
6. If O is in the middle of \overline{LT} , where exactly is it located? If $LT = 16$ cm, what is LO and OT ?
7. For three collinear points, A between T and Q :
 - a. Draw a sketch.
 - b. Write the Segment Addition Postulate for your sketch.
 - c. If $AT = 10$ in and $AQ = 5$ in, what is TQ ?
8. For three collinear points, M between H and A :
 - a. Draw a sketch.
 - b. Write the Segment Addition Postulate for your sketch.
 - c. If $HM = 18$ cm and $HA = 29$ cm, what is AM ?
9. For three collinear points, I between M and T :
 - a. Draw a sketch.
 - b. Write the Segment Addition Postulate for your sketch.
 - c. If $IT = 6$ cm and $MT = 25$ cm, what is AM ?
10. Make a sketch that matches the description: B is between A and D . C is between B and D . $AB = 7$ cm, $AC = 15$ cm, and $AD = 32$ cm. Find BC , BD , and CD .
11. Make a sketch that matches the description: E is between F and G . H is between F and E . $FH = 4$ in, $EG = 9$ in, and $FH = HE$. Find FE , HG , and FG .

For 12 and 13, Suppose J is between H and K . Use the Segment Addition Postulate to solve for x . Then find the length of each segment.

12. $HJ = 4x + 9$, $JK = 3x + 3$, $KH = 33$

13. $HJ = 5x - 3$, $JK = 8x - 9$, $KH = 131$

For 14-17, determine the vertical or horizontal distance between the two points.

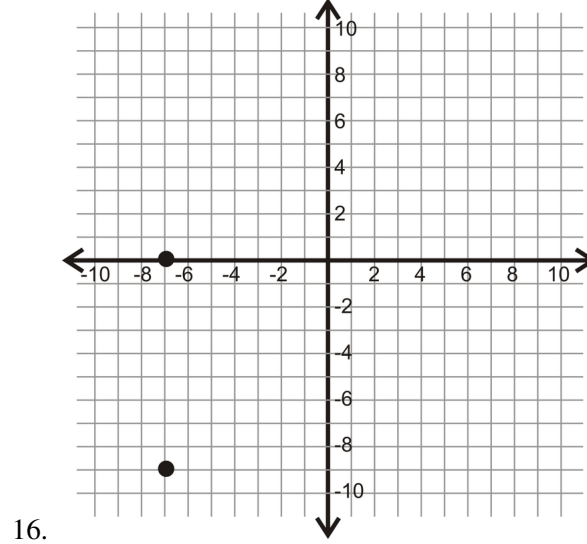
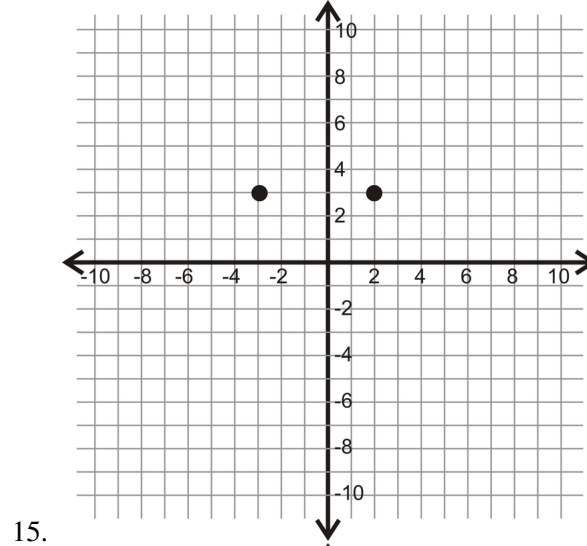
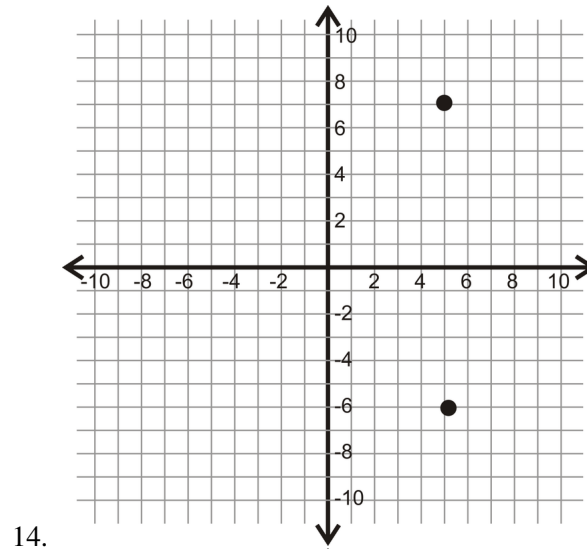

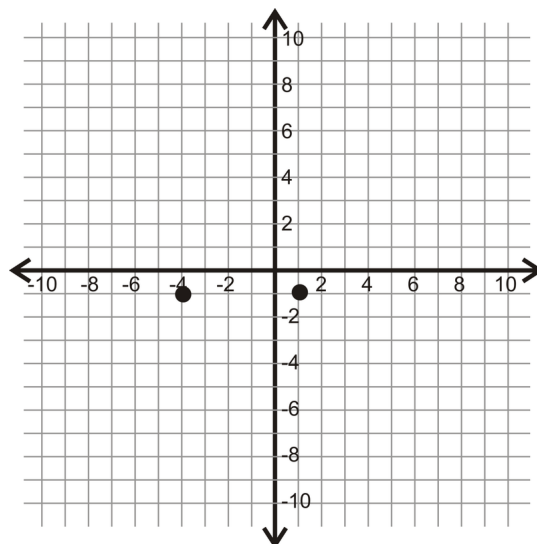

17.

18. Make a sketch of: S is between T and V . R is between S and T . $TR = 6$, $RV = 23$, and $TR = SV$.
19. Find SV , TS , RS and TV from #18.
20. For \overline{HK} , suppose that J is between H and K . If $HJ = 2x + 4$, $JK = 3x + 3$, and $KH = 22$, find x .

1.3 Congruent Angles and Angle Bisectors

Here you'll learn how to find unknown values using the definitions of angle congruency and angle bisector.

What if you were told that a line segment divides an angle in half? How would you find the measures of the two new angles formed by that segment? After completing this Concept, you'll be able to use the definitions of angle congruency and angle bisector to find such angle measures.

Watch This



MEDIA

Click image to the left for more content.

CK-12 Congruent Angles and Angle Bisectors

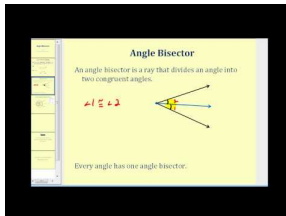

MEDIA

Click image to the left for more content.

James Sousa:Angle Bisectors

Then watch the first part of this video.

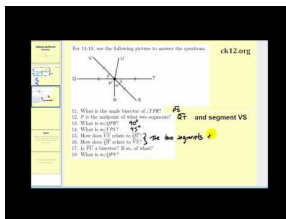

MEDIA

Click image to the left for more content.

James Sousa:Angle Bisector Exercise2

Guidance

When two geometric figures have the same shape and size (or the same angle measure in the case of angles) they are said to be **congruent**.

TABLE 1.6:

Label It

$$\angle ABC \cong \angle DEF$$

Say It

Angle ABC is congruent to angle DEF .

If two angles are congruent, then they are also equal. To label equal angles we use **angle markings**, as shown below:

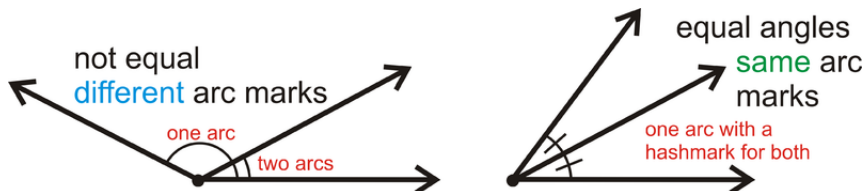

An **angle bisector** is a line, or a portion of a line, that divides an angle into two congruent angles, each having a measure exactly half of the original angle. Every angle has exactly one angle bisector.

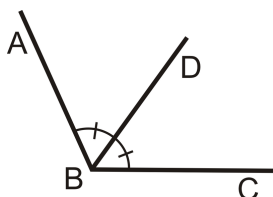

In the picture above, \overline{BD} is the angle bisector of $\angle ABC$, so $\angle ABD \cong \angle DBC$ and $m\angle ABD = \frac{1}{2}m\angle ABC$.

Example A

Write all equal angle statements.

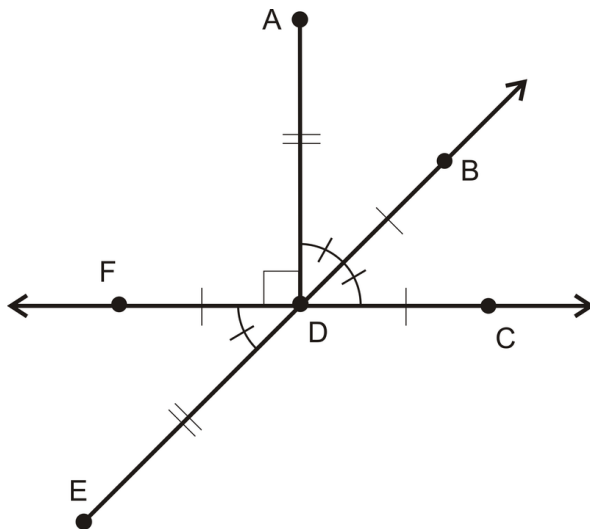

$$m\angle ADB = m\angle BDC = m\angle FDE = 45^\circ$$

$$m\angle ADF = m\angle ADC = 90^\circ$$

Example B

What is the measure of each angle?

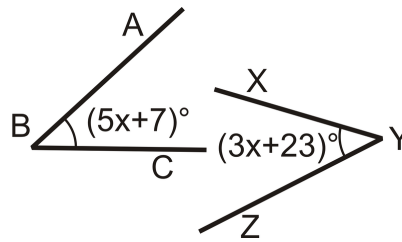

From the picture, we see that the angles are equal.

Set the angles equal to each other and solve.

$$\begin{aligned}(5x + 7)^\circ &= (3x + 23)^\circ \\ (2x)^\circ &= 16^\circ \\ x &= 8\end{aligned}$$

To find the measure of $\angle ABC$, plug in $x = 8$ to $(5x + 7)^\circ \rightarrow (5(8) + 7)^\circ = (40 + 7)^\circ = 47^\circ$. Because $m\angle ABC = m\angle XYZ$, $m\angle XYZ = 47^\circ$ too.

Example C

Is \overline{OP} the angle bisector of $\angle SOT$?

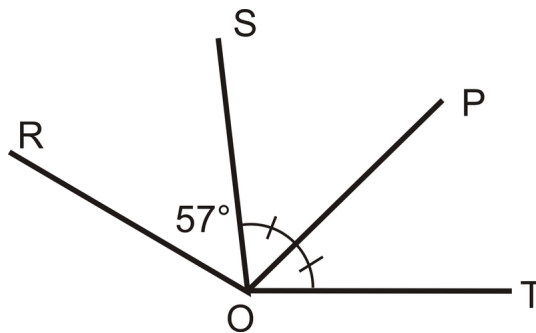

Yes, \overline{OP} is the angle bisector of $\angle SOT$ from the markings in the picture.



MEDIA

Click image to the left for more content.

Guided Practice

For exercises 1 and 2, copy the figure below and label it with the following information:

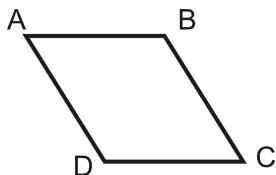

1. $\angle A \cong \angle C$
2. $\angle B \cong \angle D$
3. Use algebra to determine the value of d :

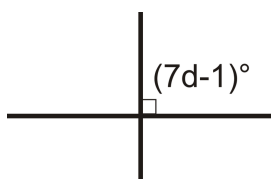

Answers:

1. You should have corresponding markings on $\angle A$ and $\angle C$.
2. You should have corresponding markings on $\angle B$ and $\angle D$ (that look different from the markings you made in #1).
3. The square marking means it is a 90° angle, so the two angles are congruent. Set up an equation and solve:

$$7d - 1 = 2d + 14$$

$$5d = 15$$

$$d = 3$$

Practice

For 1-4, use the following picture to answer the questions.

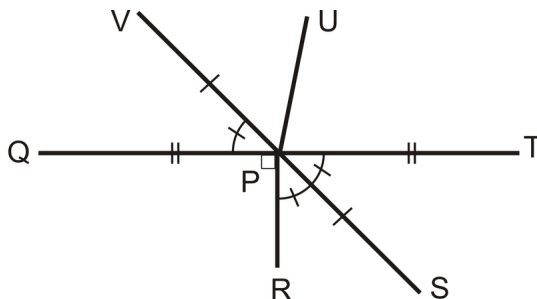

1. What is the angle bisector of $\angle TPR$?
2. What is $m\angle QPR$?
3. What is $m\angle TPS$?
4. What is $m\angle QPV$?

For 5-6, use algebra to determine the value of variable in each problem.

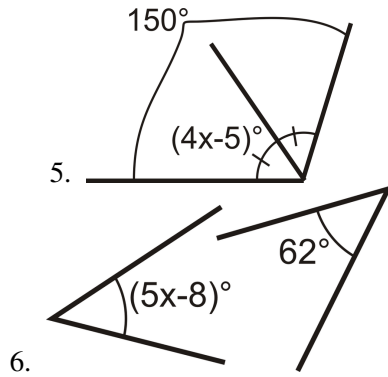

For 7-10, decide if the statement is true or false.

7. Every angle has exactly one angle bisector.
8. Any marking on an angle means that the angle is 90° .
9. An angle bisector divides an angle into three congruent angles.
10. Congruent angles have the same measure.

1.4 Midpoints and Segment Bisectors

Here you'll learn what a midpoint, a segment bisector, and a perpendicular bisector are and how to use their properties to solve for unknown values.

What if you were given the coordinates of two points and you wanted to find the point exactly in the middle of them? How would you find the coordinates of this third point? After completing this Concept, you'll be able to use the Midpoint Formula to find the location of such a point in the coordinate plane.

Watch This



MEDIA

Click image to the left for more content.

CK-12 Midpoints and Segment Bisectors

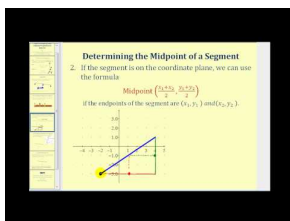

MEDIA

Click image to the left for more content.

James Sousa:SegmentMidpoint and Segment Perpendicular Bisector

Then watch this video the first part of this video.

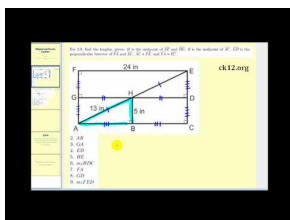

MEDIA

Click image to the left for more content.

James Sousa:Midpoint Exercise 1

Guidance

When two segments are congruent, we indicate that they are congruent, or of equal length, with **segment markings**, as shown below:



A **midpoint** is a point on a line segment that divides it into two congruent segments.

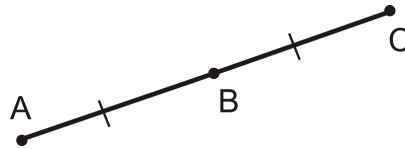

Because $AB = BC$, B is the midpoint of \overline{AC} . Any line segment will have exactly one midpoint.

When points are plotted in the coordinate plane, we can use a formula to find the midpoint between them.

Here are two points, $(-5, 6)$ and $(3, 2)$.

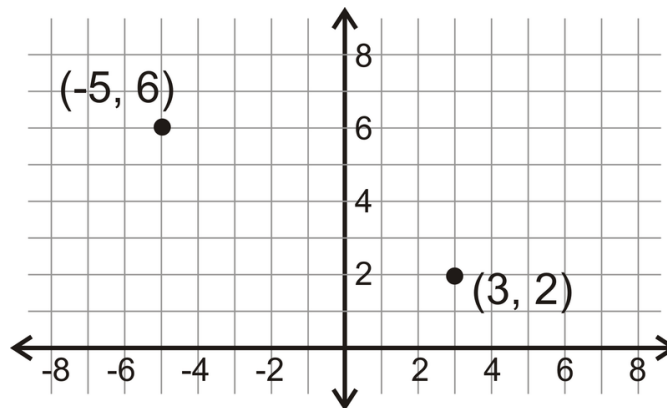

The midpoint should be halfway between the points on the segment connecting them. Just by looking, it seems like the midpoint is $(-1, 4)$.

Midpoint Formula: For two points, (x_1, y_1) and (x_2, y_2) , the midpoint is $(\frac{x_1+x_2}{2}, \frac{y_1+y_2}{2})$.

Let's use the formula to make sure $(-1, 4)$ is the midpoint between $(-5, 6)$ and $(3, 2)$.

$$\left(\frac{-5+3}{2}, \frac{6+2}{2}\right) = \left(\frac{-2}{2}, \frac{8}{2}\right) = (-1, 4)$$

A **segment bisector** cuts a line segment into two congruent parts and passes through the midpoint. A **perpendicular bisector** is a segment bisector that intersects the segment at a right angle.

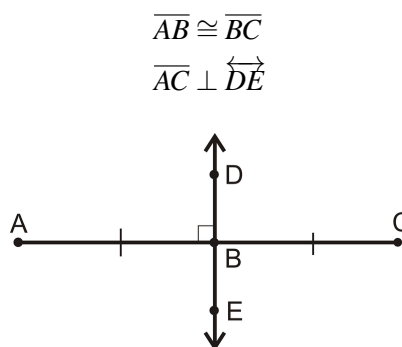

Example A

Write all equal segment statements.

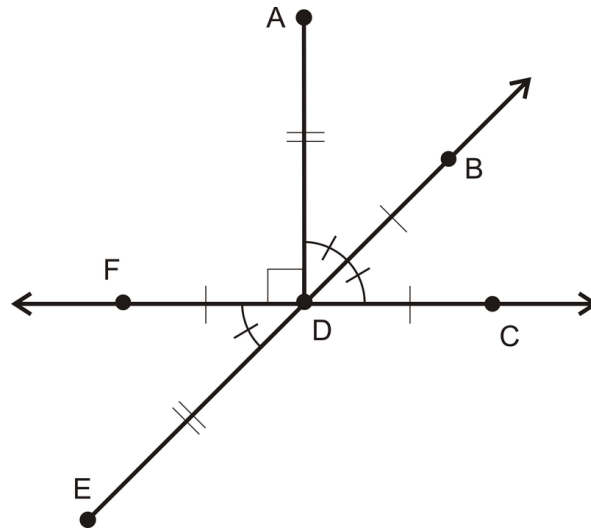

$$AD = DE$$

$$FD = DB = DC$$

Example B

Is M a midpoint of \overline{AB} ?

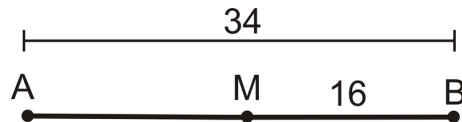

No, it is not $MB = 16$ and $AM = 34 - 16 = 18$. AM must equal MB in order for M to be the midpoint of \overline{AB} .

Example C

Find the midpoint between $(9, -2)$ and $(-5, 14)$.

Plug the points into the formula.

$$\left(\frac{9 + (-5)}{2}, \frac{-2 + 14}{2} \right) = \left(\frac{4}{2}, \frac{12}{2} \right) = (2, 6)$$



MEDIA

Click image to the left for more content.

CK-12 Midpoints and Segment Bisectors

Guided Practice

- If $M(3, -1)$ is the midpoint of \overline{AB} and $B(7, -6)$, find A .
- Which line is the perpendicular bisector of \overline{MN} ?

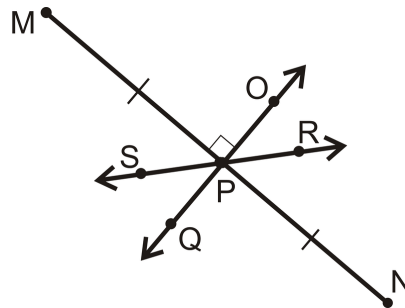

- Find x and y .

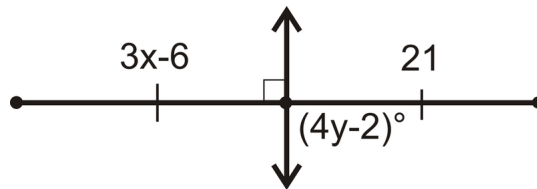

Answers:

- Plug what you know into the midpoint formula.

$$\left(\frac{7 + x_A}{2}, \frac{-6 + y_A}{2} \right) = (3, -1)$$

$$\frac{7 + x_A}{2} = 3 \text{ and } \frac{-6 + y_A}{2} = -1$$

$$7 + x_A = 6 \text{ and } -6 + y_A = -2$$

$$x_A = -1 \text{ and } y_A = 4$$

So, A is $(-1, 4)$.

- The perpendicular bisector must bisect \overline{MN} and be perpendicular to it. Only \overleftrightarrow{OQ} fits this description. \overleftrightarrow{SR} is a bisector, but is not perpendicular.
- The line shown is the perpendicular bisector.

$$\text{So, } 3x - 6 = 21$$

$$3x = 27$$

$$x = 9$$

$$\text{And, } (4y - 2)^\circ = 90^\circ$$

$$4y^\circ = 92^\circ$$

$$y = 23$$

Practice

1. Copy the figure below and label it with the following information:

$$\overline{AB} \cong \overline{CD}$$

$$\overline{AD} \cong \overline{BC}$$

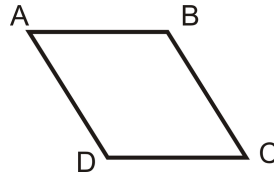

For 2-4, use the following picture to answer the questions.

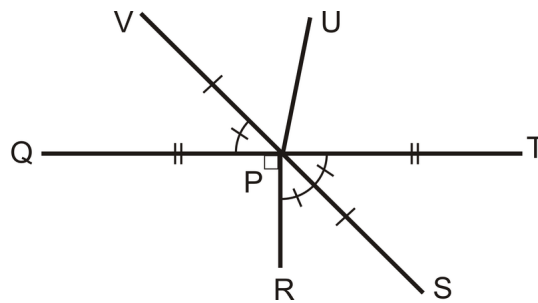

2. P is the midpoint of what two segments?
3. How does \overline{VS} relate to \overline{QT} ?
4. How does \overline{QT} relate to \overline{VS} ?

For exercise 5, use algebra to determine the value of variable in each problem.

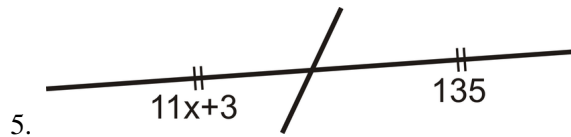

For questions 6-10, find the midpoint between each pair of points.

6. $(-2, -3)$ and $(8, -7)$
7. $(9, -1)$ and $(-6, -11)$
8. $(-4, 10)$ and $(14, 0)$
9. $(0, -5)$ and $(-9, 9)$
10. $(-3, -5)$ and $(2, 1)$

Given the midpoint (M) and either endpoint of \overline{AB} , find the other endpoint.

11. $A(-1, 2)$ and $M(3, 6)$
12. $B(-10, -7)$ and $M(-2, 1)$

1.5 Angle Measurement

Here you'll learn how to measure an angle with a protractor and how to apply the Angle Addition Postulate to find unknown values.

What if you were given the measure of an angle and two unknown quantities that make up that angle? How would you find the values of those quantities? After completing this Concept, you'll be able to use the Angle Addition Postulate to evaluate such quantities.

Watch This



MEDIA

Click image to the left for more content.

CK-12 Measuring Angles

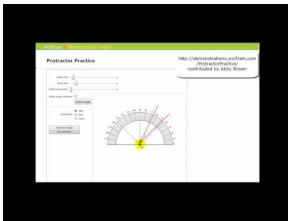

MEDIA

Click image to the left for more content.

James Sousa: Animation of Measuring Angles with a Protractor

Then look at the first part of this video.

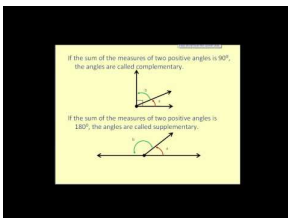

MEDIA

Click image to the left for more content.

James Sousa: Angle Basics

Guidance

An **angle** is formed when two rays have the same endpoint. The **vertex** is the common endpoint of the two rays that form an angle. The **sides** are the two rays that form an angle.

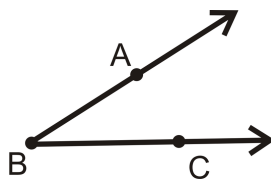
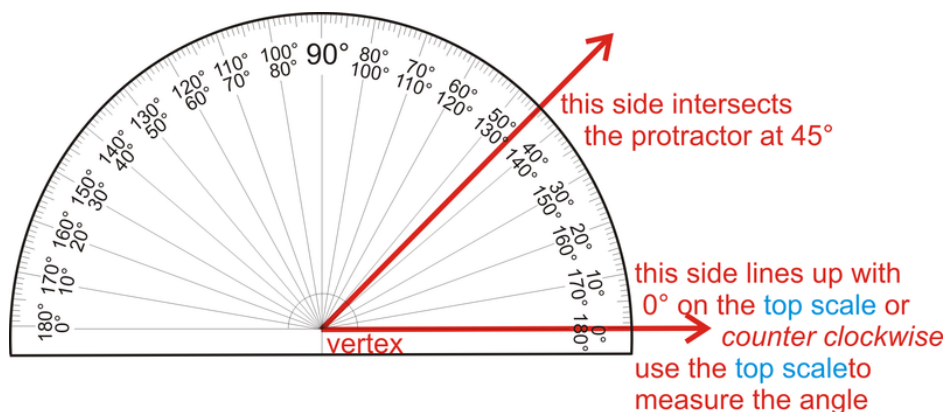

TABLE 1.7:

<i>Label It</i>	<i>Say It</i>
$\angle ABC$	Angle ABC
$\angle CBA$	Angle CBA

The vertex is B and the sides are \overrightarrow{BA} and \overrightarrow{BC} . Always use three letters to name an angle, \angle **SIDE-VERTEX-SIDE**.

Angles are measured with something called a **protractor**. A protractor is a measuring device that measures how “open” an angle is. Angles are measured in degrees and are labeled with a $^\circ$ symbol. For now, angles are always positive.



There are two sets of measurements, one starting on the left and the other on the right side of the protractor. Both go around from 0° to 180° . When measuring angles, you can line up one side with 0° , and see where the other side hits the protractor. The vertex lines up in the middle of the bottom line.

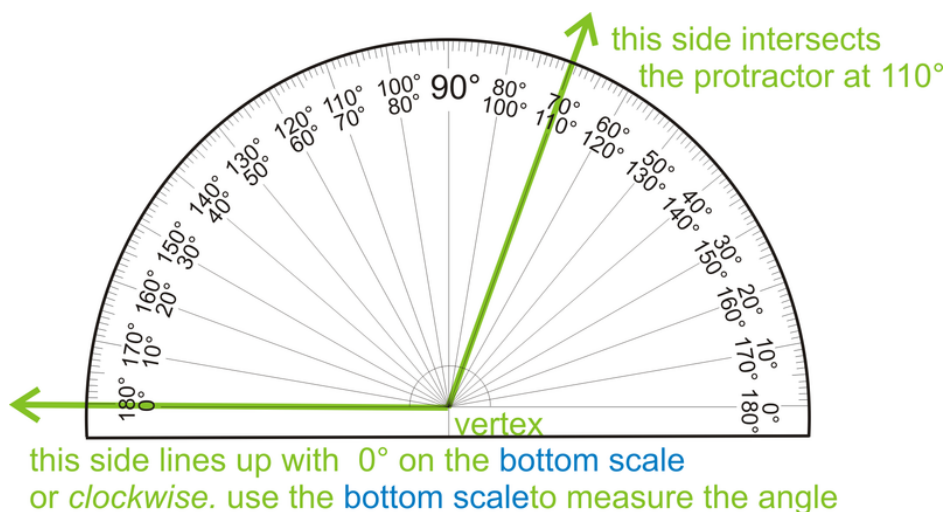

Note that if you don't line up one side with 0° , the angle's measure will be the difference of the degrees where the sides of the angle intersect the protractor.

Sometimes you will want to draw an angle that is a specific number of degrees. Follow the steps below to draw a 50° angle with a protractor:

1. Start by drawing a horizontal line across the page, 2 in long.



2. Place an endpoint at the left side of your line.
3. Place the protractor on this point, such that the line passes through the 0° mark on the protractor and the endpoint is at the center. Mark 50° on the appropriate scale.

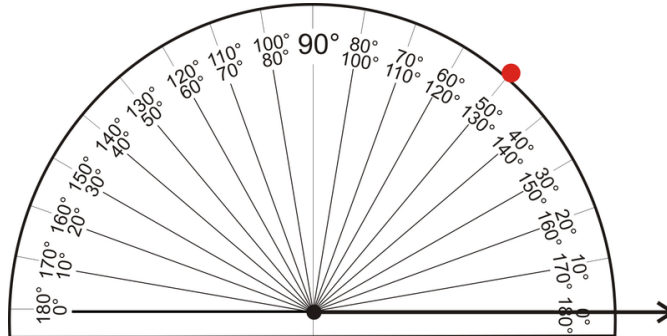

4. Remove the protractor and connect the vertex and the 50° mark.

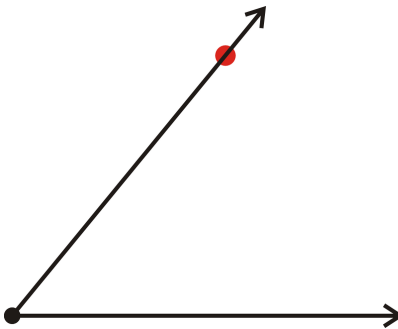

This process can be used to draw any angle between 0° and 180° . See <http://www.mathsisfun.com/geometry/protractor-using.html> for an **animation** of this.

When two smaller angles form to make a larger angle, the sum of the measures of the smaller angles will equal the measure of the larger angle. This is called the **Angle Addition Postulate**. So, if B is on the interior of $\angle ADC$, then

$$m\angle ADC = m\angle ADB + m\angle BDC$$

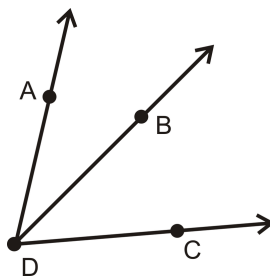

Example A

How many angles are in the picture below? Label each one.

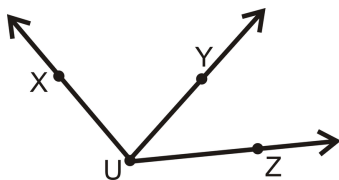

There are three angles with vertex U . It might be easier to see them all if we separate them.

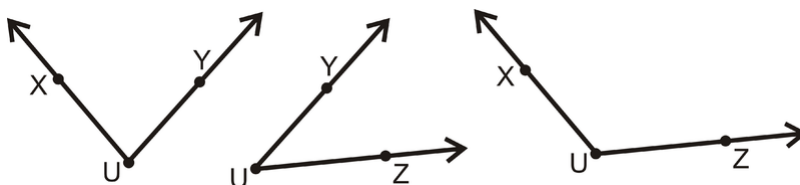

So, the three angles can be labeled, $\angle XUY$ (or $\angle YUX$), $\angle YUZ$ (or $\angle ZUY$), and $\angle XUZ$ (or $\angle ZUX$).

Example B

Measure the three angles from Example 1, using a protractor.

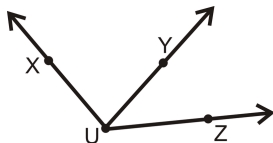

Just like in Example A, it might be easier to measure these three angles if we separate them.

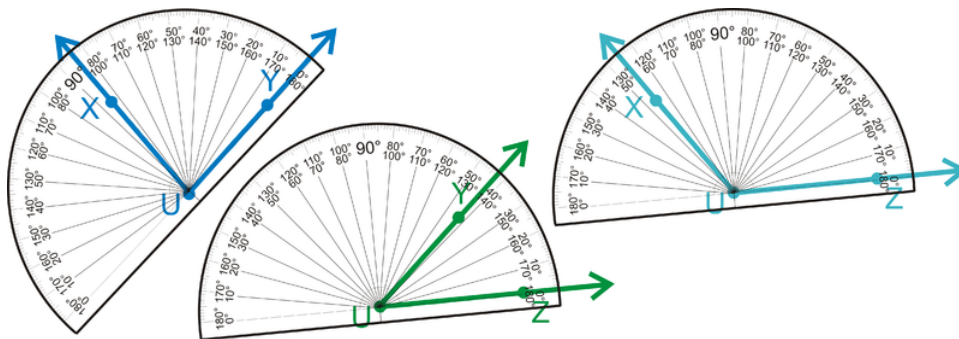

With measurement, we put an m in front of the \angle sign to indicate measure. So, $m\angle XUY = 84^\circ$, $m\angle YUZ = 42^\circ$ and $m\angle XUZ = 126^\circ$.

Example C

What is the measure of the angle shown below?

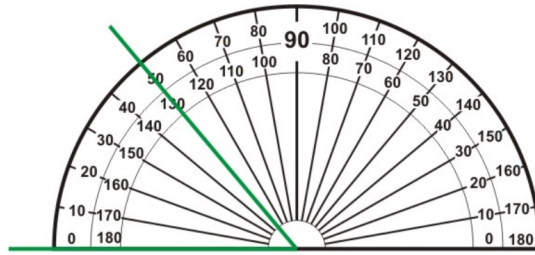

This angle is lined up with 0° , so where the second side intersects the protractor is the angle measure, which is 50° .



MEDIA

Click image to the left for more content.

CK-12 Measuring Angles

Guided Practice

1. What is the measure of the angle shown below?

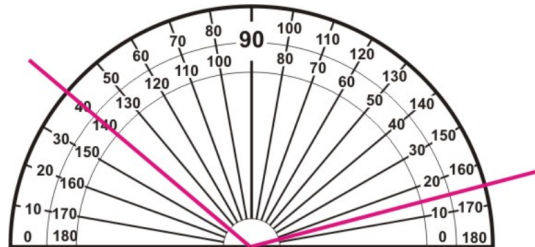

2. Use a protractor to measure $\angle RST$ below.

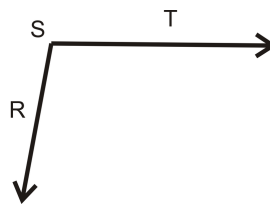

3. What is $m\angle QRT$ in the diagram below?

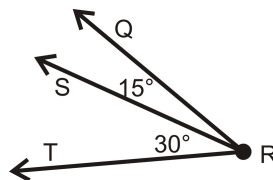

Answers

1. This angle is not lined up with 0° , so use subtraction to find its measure. It does not matter which scale you use.

Inner scale: $140^\circ - 15^\circ = 125^\circ$

Outer scale: $165^\circ - 40^\circ = 125^\circ$

2. Lining up one side with 0° on the protractor, the other side hits 100° .

3. Using the Angle Addition Postulate, $m\angle QRT = 15^\circ + 30^\circ = 45^\circ$.

Practice

1. What is $m\angle LMN$ if $m\angle LMO = 85^\circ$ and $m\angle NMO = 53^\circ$?

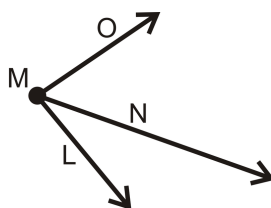

2. If $m\angle ABD = 100^\circ$, find x .

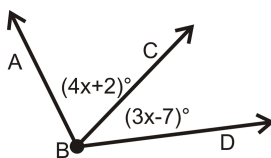

For questions 3-6, determine if the statement is true or false.

3. For an angle $\angle ABC$, C is the vertex.
4. For an angle $\angle ABC$, \overline{AB} and \overline{BC} are the sides.
5. The m in front of $m\angle ABC$ means measure.
6. The Angle Addition Postulate says that an angle is equal to the sum of the smaller angles around it.

For 7-12, draw the angle with the given degree, using a protractor and a ruler.

7. 55°
8. 92°
9. 178°
10. 5°
11. 120°
12. 73°

For 13-16, use a protractor to determine the measure of each angle.

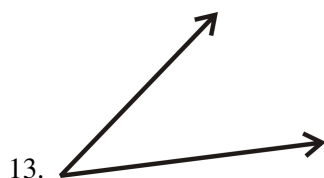

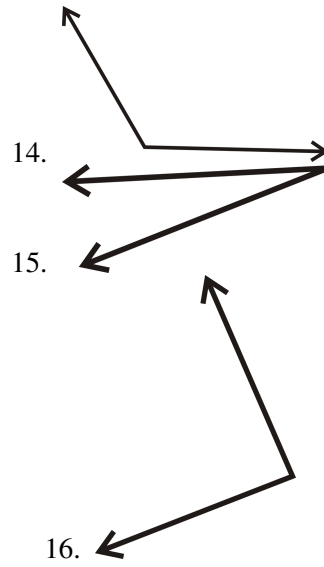

Solve for x .

17. $m\angle ADC = 56^\circ$

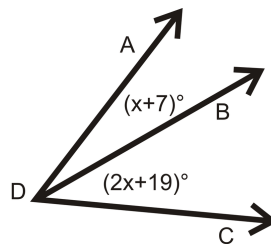

1.6 Angle Classification

Here you'll learn how to classify angles based on their angle measure.

What if you were given the degree measure of an angle? How would you describe that angle based on its size? After completing this Concept, you'll be able to classify an angle as acute, right, obtuse, or straight.

Watch This



MEDIA

Click image to the left for more content.

CK-12 Classifying an Angle



MEDIA

Click image to the left for more content.

James Sousa: Animation of Types of Angles

Guidance

Angles can be grouped into four different categories.

Straight Angle: An angle that measures exactly 180° .



Acute Angles: Angles that measure between 0° and up to but not including 90° .



Obtuse Angles: Angles that measure more than 90° but less than 180° .

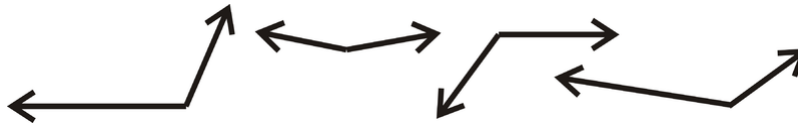

Right Angle: An angle that measures exactly 90° .

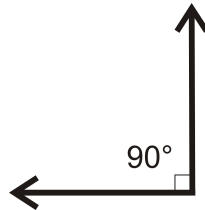

This half-square marks right, or 90° , angles. When two lines intersect to form four right angles, the lines are **perpendicular**. The symbol for perpendicular is \perp .

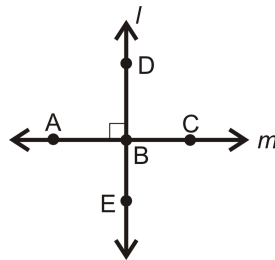

Even though all four angles are 90° , only one needs to be marked with the half-square. $l \perp m$ is read l is perpendicular to line m .

Example A

What type of angle is 84° ?

84° is less than 90° , so it is **acute**.

Example B

Name the angle and determine what type of angle it is.

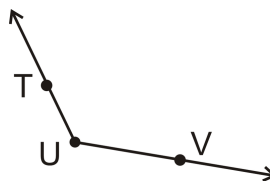

The vertex is U . So, the angle can be $\angle TUV$ or $\angle VUT$. To determine what type of angle it is, compare it to a right angle.

Because it opens wider than a right angle and is less than a straight angle, it is **obtuse**.

Example C

What type of angle is 165° ?

165° is greater than 90° , but less than 180° , so it is **obtuse**.

**MEDIA**

Click image to the left for more content.

CK-12 Classifying an Angle**Guided Practice**

Name each type of angle:

1. 90°
2. 67°
3. 180°

Answers

1. Right
2. Acute
3. Straight

Practice

For exercises 1-4, determine if the statement is true or false.

1. Two angles always add up to be greater than 90° .
2. 180° is an obtuse angle.
3. 180° is a straight angle.
4. Two perpendicular lines intersect to form four right angles.

For exercises 5-10, state what type of angle it is.

5. 55°
6. 92°
7. 178°
8. 5°
9. 120°
10. 73°

In exercises 11-15, use the following information: Q is in the interior of $\angle ROS$. S is in the interior of $\angle QOP$. P is in the interior of $\angle SOT$. S is in the interior of $\angle ROT$ and $m\angle ROT = 160^\circ$, $m\angle SOT = 100^\circ$, and $m\angle ROQ = m\angle QOS = m\angle POT$.

11. Make a sketch.

12. Find $m\angle QOP$.
13. Find $m\angle QOT$.
14. Find $m\angle ROQ$.
15. Find $m\angle SOP$.

1.7 Complementary Angles

Here you'll learn what complementary angles are and how to solve complementary angle problems.

What if you were given two angles of unknown size and were told they are complementary? How would you determine their angle measures? After completing this Concept, you'll be able to use the definition of complementary angles to solve problems like this one.

Watch This



MEDIA

Click image to the left for more content.

CK-12 Complementary Angles

Watch this video beginning at around the 3:20 mark.

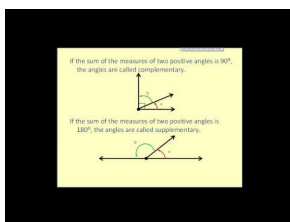

MEDIA

Click image to the left for more content.

James Sousa:Angle Basics–ComplementaryAngles

Then watch the first part of this video.

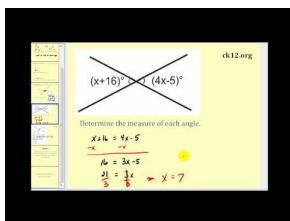

MEDIA

Click image to the left for more content.

James Sousa:Complementary Angles

Guidance

Two angles are **complementary** if they add up to 90° . Complementary angles **do not** have to be *congruent* or *next to each other*.

Example A

The two angles below are complementary. $m\angle GHI = x$. What is x ?

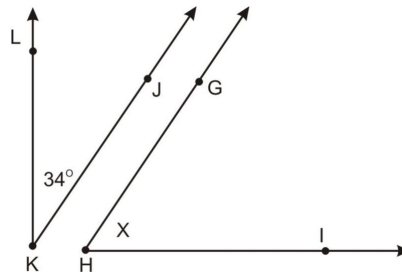

Because the two angles are complementary, they add up to 90° . Make an equation.

$$\begin{aligned}x + 34^\circ &= 90^\circ \\x &= 56^\circ\end{aligned}$$

Example B

The two angles below are complementary. Find the measure of each angle.

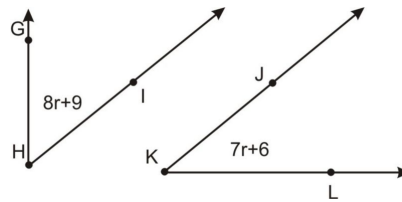

The two angles add up to 90° . Make an equation.

$$\begin{aligned}(8r + 9) + (7r + 6) &= 90 \\(15r + 15) &= 90 \\15r &= 75 \\r &= 5\end{aligned}$$

However, you need to find each angle. Plug r back into each expression.

$$\begin{aligned}m\angle GHI &= 8(5^\circ) + 9^\circ = 49^\circ \\m\angle JKL &= 7(5^\circ) + 6^\circ = 41^\circ\end{aligned}$$

Example C

Find the measure of an angle that is complementary to $\angle MRS$ if $m\angle MRS$ is 70° .

Because complementary angles have to add up to 90° , the other angle must be $90^\circ - 70^\circ = 20^\circ$.



MEDIA

Click image to the left for more content.

CK-12 Complementary Angles

Guided Practice

Find the measure of an angle that is complementary to $\angle ABC$ if $m\angle ABC$ is:

1. 45°
2. 82°
3. 19°
4. 12°

Answers:

1. Because complementary angles have to add up to 90° , the other angle must be $90^\circ - 45^\circ = 45^\circ$.
2. Because complementary angles have to add up to 90° , the other angle must be $90^\circ - 82^\circ = 8^\circ$.
3. Because complementary angles have to add up to 90° , the other angle must be $90^\circ - 19^\circ = 71^\circ$.
4. Because complementary angles have to add up to 90° , the other angle must be $90^\circ - 12^\circ = 78^\circ$.

Practice

Find the measure of an angle that is complementary to $\angle ABC$ if $m\angle ABC$ is:

1. 4°
2. 89°
3. 54°
4. 32°
5. 27°
6. $(x+y)^\circ$
7. z°

Use the diagram below for exercises 8-9. Note that $\overline{NK} \perp \overleftrightarrow{IL}$.

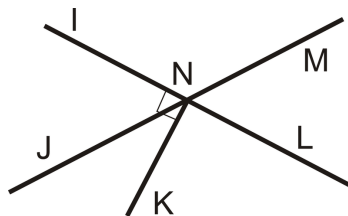

8. Name two complementary angles.
9. If $m\angle INJ = 63^\circ$, find $m\angle KNJ$.

For 10-11, determine if the statement is true or false.

10. Complementary angles add up to 180° .
11. Complementary angles are always 45° .

1.8 Supplementary Angles

Here you'll learn what supplementary angles are and how to solve supplementary angle problems.

What if you were given two angles of unknown size and were told they are supplementary? How would you determine their angle measures? After completing this Concept, you'll be able to use the definition of supplementary angles to solve problems like this one.

Watch This



MEDIA

Click image to the left for more content.

CK-12 Basic Geometric Definitions

Watch this video beginning at around the 3:20 mark.

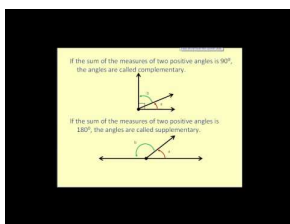

MEDIA

Click image to the left for more content.

James Sousa: Angle Basics—Supplementary Angles

Then watch the second part of this video.

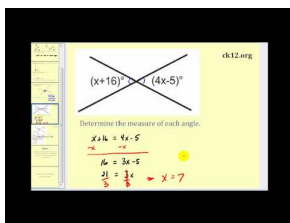

MEDIA

Click image to the left for more content.

James Sousa: Supplementary Angles

Guidance

Two angles are **supplementary** if they add up to 180° . Supplementary angles **do not** have to be *congruent* or *next to each other*.

Example A

The two angles below are supplementary. If $m\angle MNO = 78^\circ$ what is $m\angle PQR$?

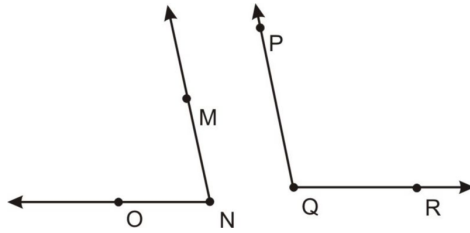

Set up an equation. However, instead of equating 90° , now the sum is 180° .

$$78^\circ + m\angle PQR = 180^\circ$$

$$m\angle PQR = 102^\circ$$

Example B

What are the measures of two congruent, supplementary angles?

Supplementary angles add up to 180° . Congruent angles have the same measure. So, $180^\circ \div 2 = 90^\circ$, which means two congruent, supplementary angles are right angles, or 90° .

Example C

Find the measure of an angle that is supplementary to $\angle MRS$ if $m\angle MRS$ is 70° .

Because supplementary angles have to add up to 180° , the other angle must be $180^\circ - 70^\circ = 110^\circ$.

Guided Practice

Find the measure of an angle that is supplementary to $\angle ABC$ if $m\angle ABC$ is:

1. 45°
2. 118°
3. 32°
4. 2°

Answers:

1. Because supplementary angles have to add up to 180° , the other angle must be $180^\circ - 45^\circ = 135^\circ$.
2. Because supplementary angles have to add up to 180° , the other angle must be $180^\circ - 118^\circ = 62^\circ$.
3. Because supplementary angles have to add up to 180° , the other angle must be $180^\circ - 32^\circ = 148^\circ$.
4. Because supplementary angles have to add up to 180° , the other angle must be $180^\circ - 2^\circ = 178^\circ$.

Practice

Find the measure of an angle that is supplementary to $\angle ABC$ if $m\angle ABC$ is:

1. 114°
2. 11°
3. 91°
4. 84°
5. 57°
6. x°
7. $(x+y)^\circ$

Use the diagram below for exercises 8-9. Note that $\overline{NK} \perp \overleftrightarrow{IL}$.

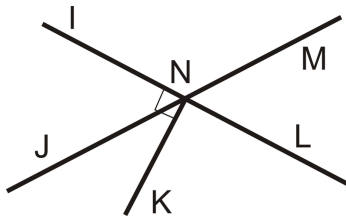

8. Name two supplementary angles.
9. If $m\angle INJ = 63^\circ$, find $m\angle JNL$.

For exercise 10, determine if the statement is true or false.

10. Supplementary angles add up to 180°

For 11-12, find the value of x .

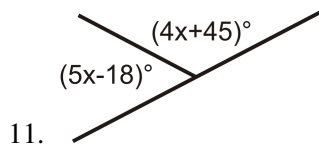

11.

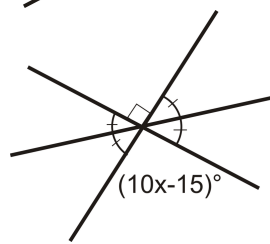

12.

1.9 Linear Pairs

Here you'll learn what linear pairs are and how to solve linear pair problems.

What if you were given two angles of unknown size and were told they form a linear pair? How would you determine their angle measures? After completing this Concept, you'll be able to use the definition of linear pair to solve problems like this one.

Watch This



MEDIA

Click image to the left for more content.

[CK-12 LinearPairs](#)

Guidance

Two angles are **adjacent** if they have the same vertex, share a side, and do not overlap. $\angle PSQ$ and $\angle QSR$ are adjacent.

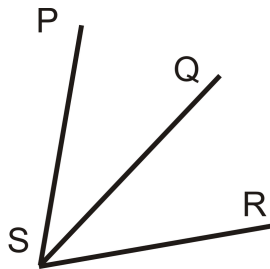

A **linear pair** is two angles that are adjacent and whose non-common sides form a straight line. If two angles are a linear pair, then they are supplementary (add up to 180°). $\angle PSQ$ and $\angle QSR$ are a linear pair.

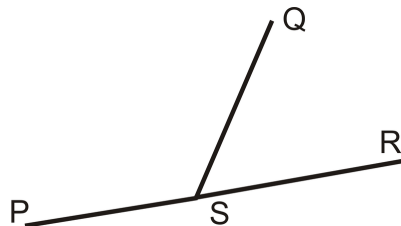

Example A

What is the measure of each angle?

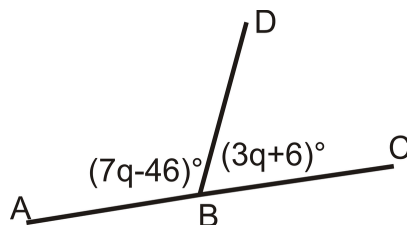

These two angles are a linear pair, so they add up to 180° .

$$\begin{aligned}(7q - 46)^\circ + (3q + 6)^\circ &= 180^\circ \\ 10q - 40^\circ &= 180^\circ \\ 10q &= 220 \\ q &= 22\end{aligned}$$

Plug in q to get the measure of each angle. $m\angle ABD = 7(22^\circ) - 46^\circ = 108^\circ$ $m\angle DBC = 180^\circ - 108^\circ = 72^\circ$

Example B

Are $\angle CDA$ and $\angle DAB$ a linear pair? Are they supplementary?

The two angles are not a linear pair because they do not have the same vertex. They are supplementary because they add up to 180° : $120^\circ + 60^\circ = 180^\circ$.

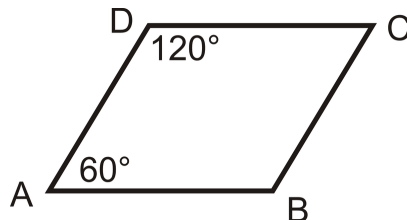

Example C

Find the measure of an angle that forms a linear pair with $\angle MRS$ if $m\angle MRS$ is 150° .

Because linear pairs have to add up to 180° , the other angle must be $180^\circ - 150^\circ = 30^\circ$.



MEDIA

Click image to the left for more content.

[CK-12 LinearPairs](#)

Guided Practice

Use the diagram below. Note that $\overline{NK} \perp \overleftrightarrow{IL}$.

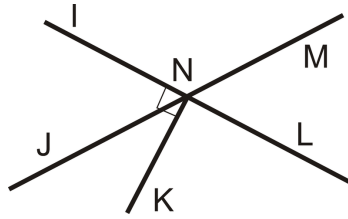

1. Name one linear pair of angles.
2. What is $m\angle INL$?
3. What is $m\angle LNK$?
4. If $m\angle INJ = 63^\circ$, find $m\angle MNI$.

Answers:

1. $\angle MNL$ and $\angle LNJ$
2. 180°
3. 90°
4. $180^\circ - 63^\circ = 117^\circ$

Practice

For 1-5, determine if the statement is true or false.

1. Linear pairs are congruent.
2. Adjacent angles share a vertex.
3. Adjacent angles overlap.
4. Linear pairs are supplementary.
5. Supplementary angles form linear pairs.

For exercise 6, find the value of x .

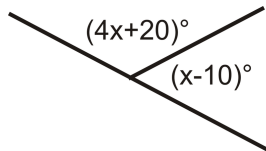

6.

Find the measure of an angle that forms a linear pair with $\angle MRS$ if $m\angle MRS$ is:

7. 61°
8. 23°
9. 114°
10. 7°
11. 179°
12. z°

1.10 Vertical Angles

Here you'll learn what vertical angles are and how to solve vertical angle problems.

What if you were given two angles of unknown size and were told they are vertical angles? How would you determine their angle measures? After completing this Concept, you'll be able to use the definition of vertical angles to solve problems like this one.

Watch This



MEDIA

Click image to the left for more content.

CK-12 Vertical Angles

Watch the first part of this video.

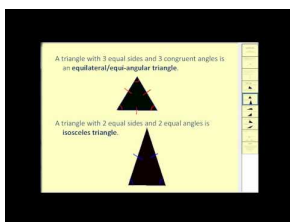

MEDIA

Click image to the left for more content.

James Sousa:Angle Relationships

Then watch the third part of this video.

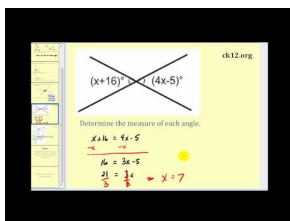

MEDIA

Click image to the left for more content.

James Sousa:Complementary Angles

Guidance

Vertical angles are two non-adjacent angles formed by intersecting lines. $\angle 1$ and $\angle 3$ are vertical angles and $\angle 2$ and $\angle 4$ are vertical angles.

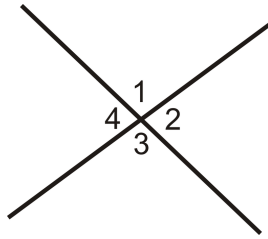

The **Vertical Angles Theorem** states that if two angles are vertical angles, then they are congruent.

Example A

Find $m\angle 1$.

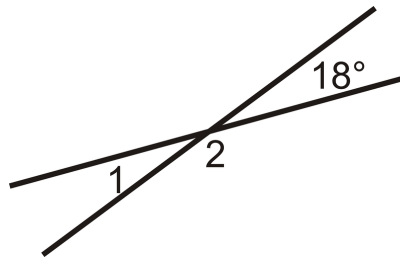

$\angle 1$ is vertical angles with 18° , so $m\angle 1 = 18^\circ$.

Example B

If $\angle ABC$ and $\angle DEF$ are vertical angles and $m\angle ABC = (4x + 10)^\circ$ and $m\angle DEF = (5x + 2)^\circ$, what is the measure of each angle?

Vertical angles are congruent, so set the angles equal to each other and solve for x . Then go back to find the measure of each angle.

$$\begin{aligned} 4x + 10 &= 5x + 2 \\ x &= 8 \end{aligned}$$

So, $m\angle ABC = m\angle DEF = (4(8) + 10)^\circ = 42^\circ$

Example C

True or false: vertical angles are always less than 90° .

This is false, you can have vertical angles that are more than 90° . Vertical angles are less than 180° .



MEDIA

Click image to the left for more content.

Guided Practice

Find the value of x or y .

1.

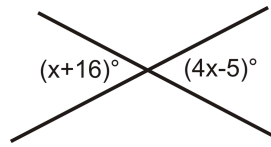

2.

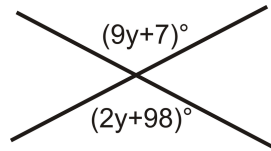

3.

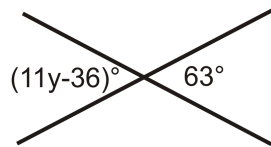
**Answers:**

1. Vertical angles are congruent, so set the angles equal to each other and solve for x .

$$\begin{aligned}x + 16 &= 4x - 5 \\3x &= 21 \\x &= 7^\circ\end{aligned}$$

2. Vertical angles are congruent, so set the angles equal to each other and solve for y .

$$\begin{aligned}9y + 7 &= 2y + 98 \\7y &= 91 \\y &= 13^\circ\end{aligned}$$

3. Vertical angles are congruent, so set the angles equal to each other and solve for y .

$$\begin{aligned}11y - 36 &= 63 \\11y &= 99 \\y &= 9^\circ\end{aligned}$$

Practice

Use the diagram below for exercises 1-2. Note that $\overline{NK} \perp \overleftrightarrow{IL}$.

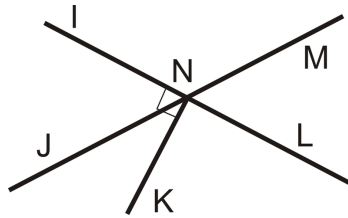

1. Name one pair of vertical angles.
2. If $m\angle INJ = 63^\circ$, find $m\angle MNL$.

For exercise 3, determine if the statement is true or false.

3. Vertical angles have the same vertex.
4. If $\angle ABC$ and $\angle DEF$ are vertical angles and $m\angle ABC = (9x + 1)^\circ$ and $m\angle DEF = (5x + 29)^\circ$, what is the measure of each angle?
5. If $\angle ABC$ and $\angle DEF$ are vertical angles and $m\angle ABC = (8x + 2)^\circ$ and $m\angle DEF = (2x + 32)^\circ$, what is the measure of each angle?
6. If $\angle ABC$ and $\angle DEF$ are vertical angles and $m\angle ABC = (x + 22)^\circ$ and $m\angle DEF = (5x + 2)^\circ$, what is the measure of each angle?
7. If $\angle ABC$ and $\angle DEF$ are vertical angles and $m\angle ABC = (3x + 12)^\circ$ and $m\angle DEF = (7x)^\circ$, what is the measure of each angle?
8. If $\angle ABC$ and $\angle DEF$ are vertical angles and $m\angle ABC = (5x + 2)^\circ$ and $m\angle DEF = (x + 26)^\circ$, what is the measure of each angle?
9. If $\angle ABC$ and $\angle DEF$ are vertical angles and $m\angle ABC = (3x + 1)^\circ$ and $m\angle DEF = (2x + 2)^\circ$, what is the measure of each angle?
10. If $\angle ABC$ and $\angle DEF$ are vertical angles and $m\angle ABC = (6x - 3)^\circ$ and $m\angle DEF = (5x + 1)^\circ$, what is the measure of each angle?

1.11 Triangle Classification

Here you'll learn how to classify triangles based on their angle and side measures.

What if you were given the angle measures and/or side lengths of a triangle? How would you describe the triangle based on that information? After completing this Concept, you'll be able to classify a triangle as right, obtuse, acute, equiangular, scalene, isosceles, and/or equilateral.

Watch This



MEDIA

Click image to the left for more content.

CK-12 LinearPairs

Watch this video beginning at around the 2:38 mark.

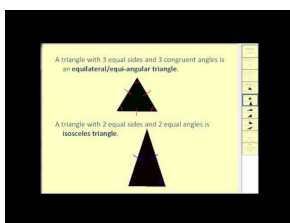

MEDIA

Click image to the left for more content.

James Sousa:Types of Triangles

Guidance

A **triangle** is any closed figure made by three line segments intersecting at their endpoints. Every triangle has three **vertices** (the points where the segments meet), three **sides** (the segments), and three **interior angles** (formed at each vertex). All of the following shapes are triangles.



The sum of the interior angles in a triangle is 180° . This is called the **Triangle Sum Theorem** and is discussed further [TriangleSumTheorem](#).

Angles can be classified by their size as acute, obtuse or right. In any triangle, two of the angles will always be acute. The third angle can be acute, obtuse, or right. *We classify each triangle by this angle.*

Right Triangle: A triangle with one right angle.

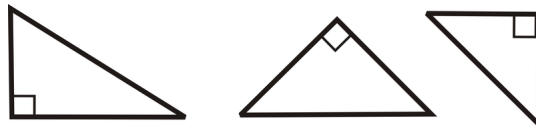

Obtuse Triangle: A triangle with one obtuse angle.

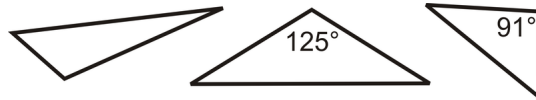

Acute Triangle: A triangle where all three angles are acute.

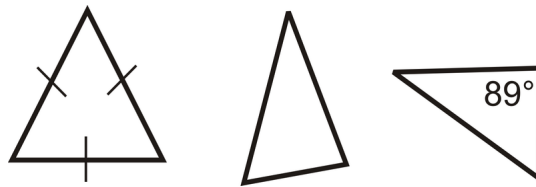

Equiangular Triangle: A triangle where all the angles are congruent.

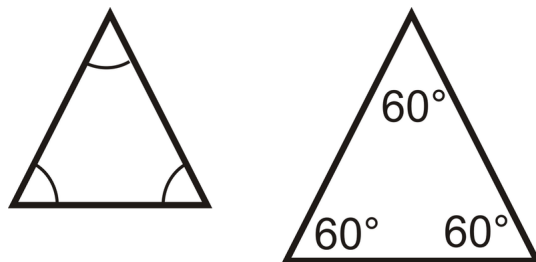

You can also classify a triangle by its sides.

Scalene Triangle: A triangle where all three sides are different lengths.

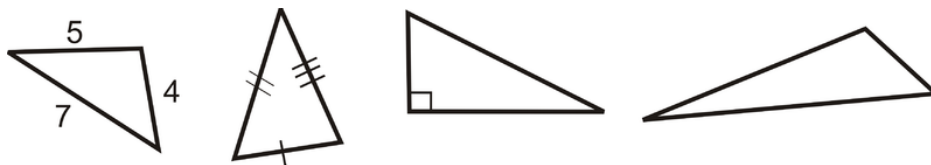

Isosceles Triangle: A triangle with *at least* two congruent sides.

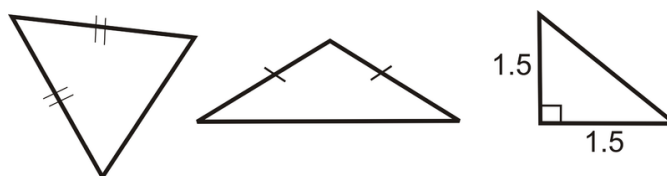

Equilateral Triangle: A triangle with three congruent sides.

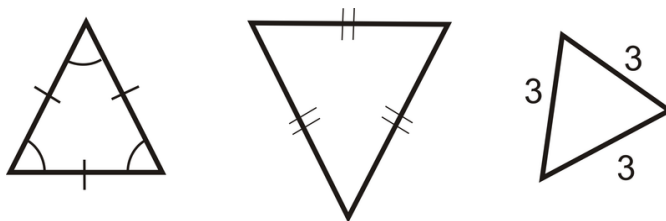

Note that from the definitions, an equilateral triangle is also an isosceles triangle.

Example A

Which of the figures below are not triangles?

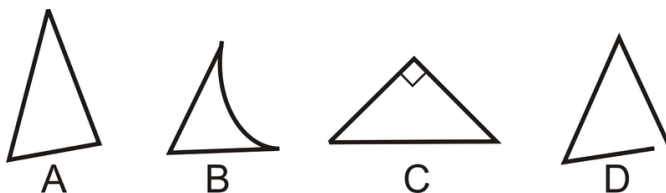

B is not a triangle because it has one curved side. *D* is not closed, so it is not a triangle either.

Example B

Which term best describes $\triangle RST$ below?

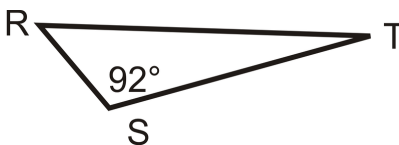

This triangle has one labeled obtuse angle of 92° . Triangles can have only one obtuse angle, so it is an obtuse triangle.

Example C

Classify the triangle by its sides and angles.

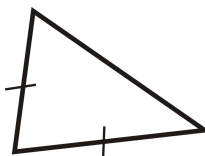

We see that there are two congruent sides, so it is isosceles. By the angles, they all look acute. We say this is an acute isosceles triangle.



MEDIA

 Click image to the left for more content.

CK-12 LinearPairs

Guided Practice

1. How many triangles are in the diagram below?

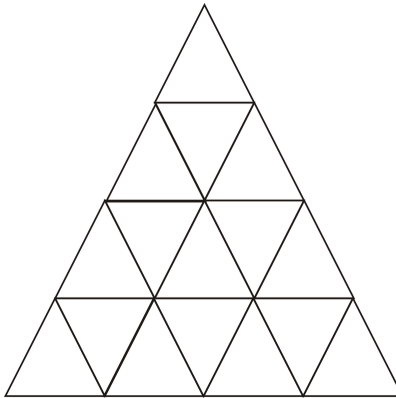

2. Classify the triangle by its sides and angles.

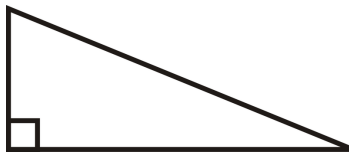

3. True or false: An equilateral triangle is equiangular.

Answers:

1. Start by counting the smallest triangles, 16.

Now count the triangles that are formed by 4 of the smaller triangles, 7.

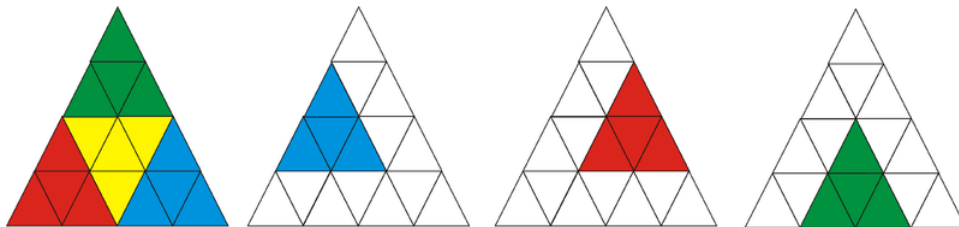

Next, count the triangles that are formed by 9 of the smaller triangles, 3.

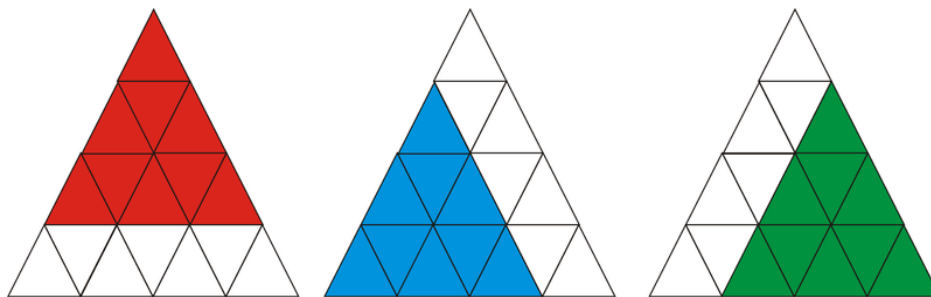

Finally, there is the one triangle formed by all 16 smaller triangles. Adding these numbers together, we get $16 + 7 + 3 + 1 = 27$.

2. This triangle has a right angle and no sides are marked congruent. So, it is a right scalene triangle.
3. True. Equilateral triangles have interior angles that are all congruent so they are equiangular.

Practice

For questions 1-6, classify each triangle by its sides and by its angles.

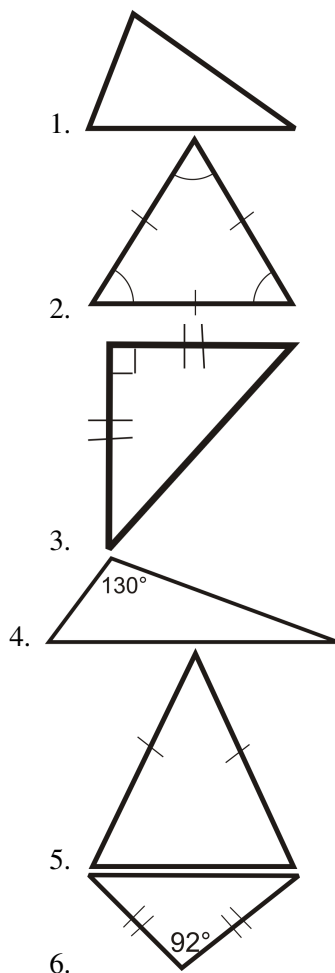

7. Can you draw a triangle with a right angle and an obtuse angle? Why or why not?
8. In an isosceles triangle, can the angles opposite the congruent sides be obtuse?

For 9-10, determine if the statement is true or false.

9. Obtuse triangles can be isosceles.
10. A right triangle is acute.

1.12 Polygon Classification

Here you'll learn how to classify a polygon based on its sides. You'll also learn how to decide whether a polygon is convex or concave.

What if you were told how many sides a polygon has? How would you describe the polygon based on that information? After completing this Concept, you'll be able to classify a polygon according to its shape and the number of sides it has.

Watch This



MEDIA

Click image to the left for more content.

CK-12 Classifying a Polygon

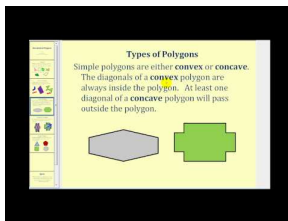

MEDIA

Click image to the left for more content.

James Sousa:Introduction to Polygons

Then watch the first part of this video.

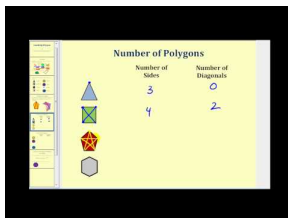

MEDIA

Click image to the left for more content.

James Sousa:Classifying Polygons

Guidance

A **polygon** is any closed, 2-dimensional figure that is made entirely of line segments that intersect at their endpoints. Polygons can have any number of sides and angles, but the sides can never be curved. The segments are called the **sides** of the polygons, and the points where the segments intersect are called **vertices**.

Polygons can be either **convex** or **concave**. The term concave refers to a cave, or the polygon is “caving in”. All stars are concave polygons.

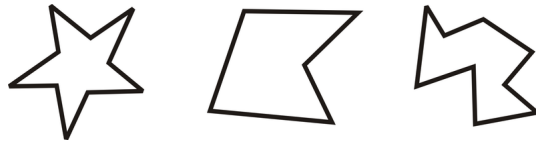

A convex polygon does not cave in. Convex polygons look like:

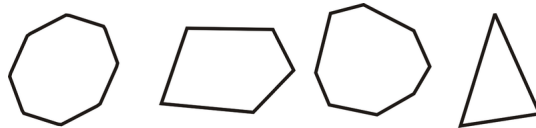

A **diagonal** is a non-side line segment that connects two vertices of a convex polygon.

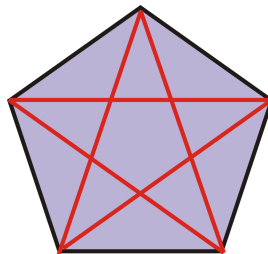

The red line segments are all diagonals. This pentagon has 5 diagonals.

Whether a polygon is convex or concave, it is always named by the number of sides. Explore the relationship between the number of sides of a convex polygon and its diagonals. Can you complete the table?

TABLE 1.8:



Polygon Name	Number of Sides	Number of Diagonals	Convex Example
Triangle	3	0	
Quadrilateral	4	2	
Pentagon	5	5	

TABLE 1.8: (continued)

Polygon Name	Number of Sides	Number of Diagonals	Convex Example
Hexagon	6	9	
Heptagon	7	?	
Octagon	8	?	
Nonagon	9	?	
Decagon	10	?	
Undecagon hendecagon	or 11	?	
Dodecagon	12	?	

TABLE 1.8: (continued)

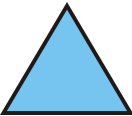
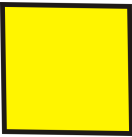
Polygon Name n-gon	Number of Sides n (where $n > 12$)	Number of Diagonals ?	Convex Example
-----------------------	--	--------------------------	----------------

**Example A**

Which of the figures below is a polygon?

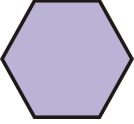
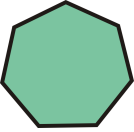
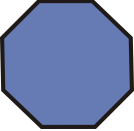
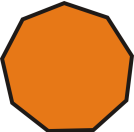
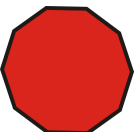
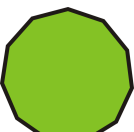
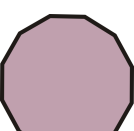
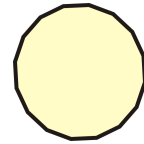
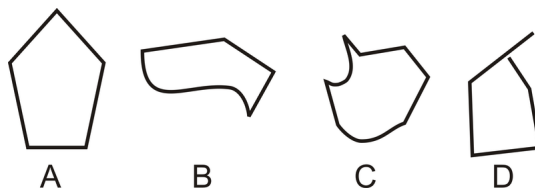

The easiest way to identify the polygon is to identify which shapes are **not** polygons. *B* and *C* each have at least one curved side, so they are not polygons. *D* has all straight sides, but one of the vertices is not at the endpoint, so it is not a polygon. *A* is the only polygon.

Example B

Determine if the shapes below are convex or concave.

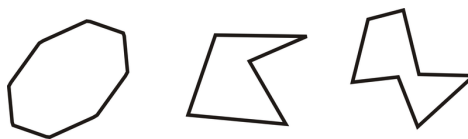

To see if a polygon is concave, look at the polygons and see if any angle “caves in” to the interior of the polygon. The first polygon does not do this, so it is convex. The other two do, so they are concave.

Example C

Name the three polygons below by their number of sides and if it is convex or concave.

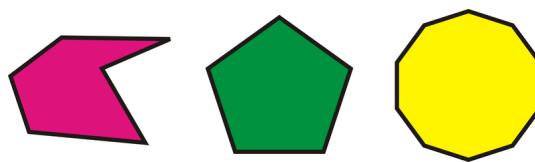

The pink polygon is a concave hexagon (6 sides).

The green polygon convex pentagon (5 sides).

The yellow polygon is a convex decagon (10 sides).



MEDIA

Click image to the left for more content.

CK-12 Classifying a Polygon

Guided Practice

1. Which of the figures below is not a polygon?

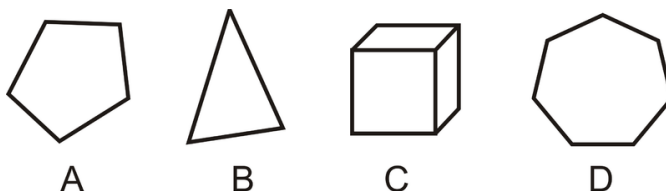

2. How many diagonals does a 7-sided polygon have?

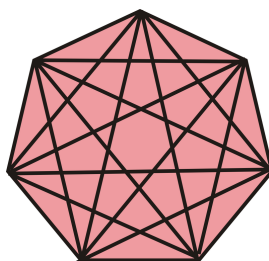

3. True or false: A quadrilateral is always a square.

Answers:

1. *C* is a three-dimensional shape, so it does not lie within one plane, so it is not a polygon.

2. Draw a 7-sided polygon, also called a heptagon.

Drawing in all the diagonals and counting them, we see there are 14.

3. False. Only quadrilaterals with four congruent sides and four right angles will be squares. There are many quadrilaterals (such as rectangles, kites, parallelograms, trapezoids, etc.) that are not necessarily squares.

Practice

In problems 1-6, name each polygon in as much detail as possible.

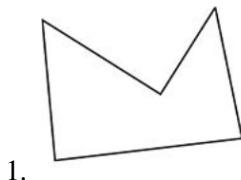

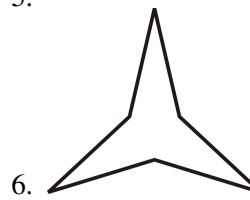
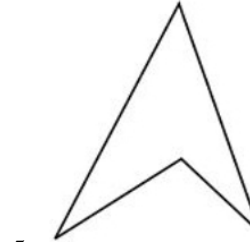
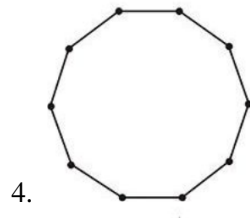
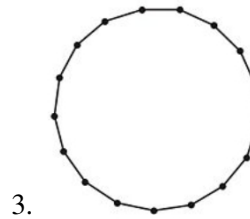
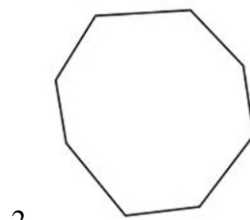

7. Explain why the following figures are NOT polygons:

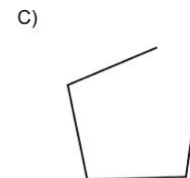
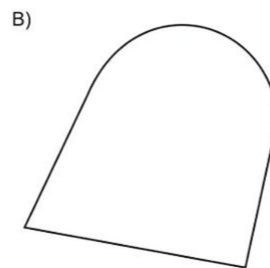
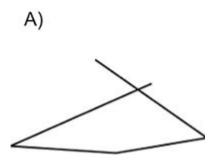

8. How many diagonals can you draw from **one vertex** of a pentagon? Draw a sketch of your answer.

9. How many diagonals can you draw from **one vertex** of an octagon? Draw a sketch of your answer.

10. How many diagonals can you draw from **one vertex** of a dodecagon?

11. Determine the number of total diagonals for an octagon, nonagon, decagon, undecagon, and dodecagon.

For 12-14, determine if the statement is true or false.

12. A polygon must be enclosed.

13. A star is a convex polygon.

14. A 5-point star is a decagon

Summary

This chapter begins with the basic components of Euclidean Geometry. From the introductory definition of points, lines, and planes it builds to a discussion of classifying figures such as angles, triangles, and polygons. Measurement of distances and angles are also covered. Different types of angle relationships are compared and explored, such as complementary angles, supplementary angles and linear pairs.

CHAPTER 2**Reasoning and Proof****Chapter Outline**

- 2.1** **INDUCTIVE REASONING FROM PATTERNS**
 - 2.2** **DEDUCTIVE REASONING**
 - 2.3** **IF-THEN STATEMENTS**
 - 2.4** **CONVERSE, INVERSE, AND CONTRAPOSITIVE**
 - 2.5** **CONJECTURES AND COUNTEREXAMPLES**
 - 2.6** **PROPERTIES OF EQUALITY AND CONGRUENCE**
 - 2.7** **TWO-COLUMN PROOFS**
-

Introduction

This chapter explains how to use reasoning to prove theorems about angle pairs and segments. This chapter also introduces the properties of congruence, which will be used in 2-column proofs.

2.1 Inductive Reasoning from Patterns

Here you'll learn how to inductively draw conclusions from patterns and examples to solve problems.

What if you were given a pattern of three numbers or shapes and asked to determine the sixth number or shape that fit that pattern? After completing this Concept, you'll be able to use inductive reasoning to draw conclusions like this based on examples and patterns provided.

Watch This



MEDIA

Click image to the left for more content.

CK-12 Types of Reasoning: Inductive

Watch the first two parts of this video.

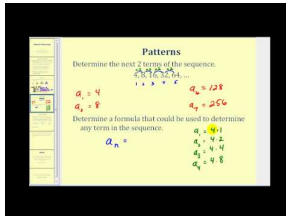

MEDIA

Click image to the left for more content.

James Sousa: Inductive Reasoning

Guidance

One type of reasoning is **inductive reasoning**. Inductive reasoning entails making conclusions based upon examples and patterns. Visual patterns and number patterns provide good examples of inductive reasoning. Let's look at some patterns to get a feel for what inductive reasoning is.

Example A

A dot pattern is shown below. How many dots would there be in the 4th figure? How many dots would be in the 6th figure?

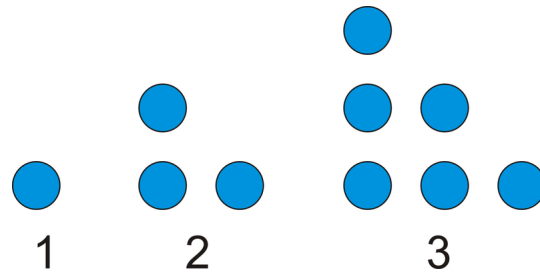

Draw a picture. Counting the dots, there are $4 + 3 + 2 + 1 = 10$ dots.

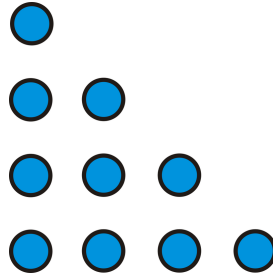

For the 6th figure, we can use the same pattern, $6 + 5 + 4 + 3 + 2 + 1$. There are 21 dots in the 6th figure.

Example B

How many *triangles* would be in the 10th figure?

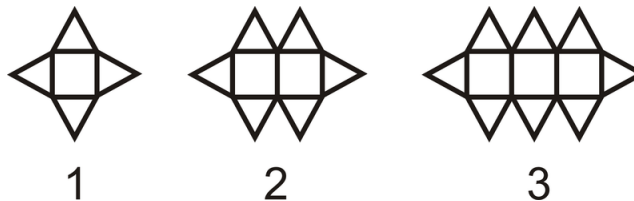

There would be 10 squares in the 10th figure, with a triangle above and below each one. There is also a triangle on each end of the figure. That makes $10 + 10 + 2 = 22$ triangles in all.

Example C

Look at the pattern 2, 4, 6, 8, 10, ... What is the 19th term in the pattern?

Each term is 2 more than the previous term.

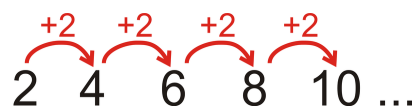

You could count out the pattern until the 19th term, but that could take a while. Notice that the 1st term is $2 \cdot 1$, the 2nd term is $2 \cdot 2$, the 3rd term is $2 \cdot 3$, and so on. So, the 19th term would be $2 \cdot 19$ or 38.



MEDIA

Click image to the left for more content.

CK-12 Types of Reasoning: Inductive

Guided Practice

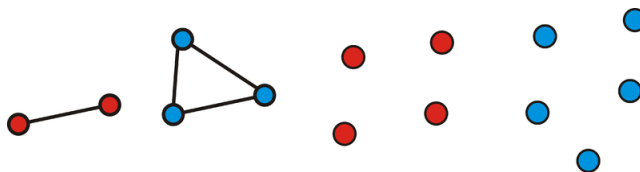
1. For two points, there is one line segment connecting them. For three non-collinear points, there are three segments. For four points, how many line segments can be drawn to connect them? If you add a fifth point, how many line segments can be drawn to connect the five points?



2. Look at the pattern 1, 3, 5, 7, 9, 11, ... What is the 34^{th} term in the pattern?

3. Look at the pattern: 3, 6, 12, 24, 48, ...

a) What is the next term in the pattern?

b) What is the 10^{th} term?

4. Find the 8^{th} term in the list of numbers: $2, \frac{3}{4}, \frac{4}{9}, \frac{5}{16}, \frac{6}{25}, \dots$

Answers:

1. Draw a picture of each and count the segments.

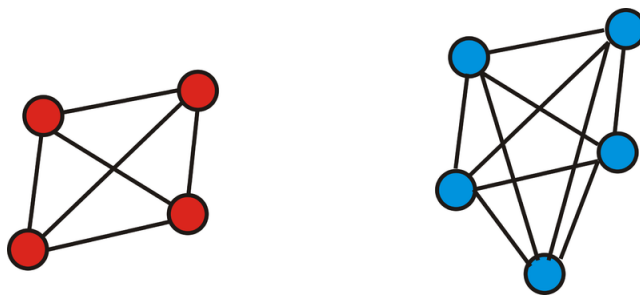

For 4 points there are 6 line segments and for 5 points there are 10 line segments.

2. The next term would be 13 and continue go up by 2. Comparing this pattern to Example C, each term is one less. So, we can reason that the 34^{th} term would be $34 \cdot 2$ minus 1, which is 67.

3. Each term is *multiplied* by 2 to get the next term.

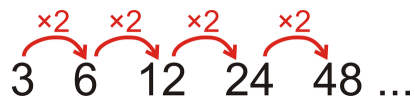

Therefore, the next term will be $48 \cdot 2$ or 96. To find the 10^{th} term, continue to multiply by 2, or $3 \cdot \underbrace{2 \cdot 2 \cdot 2 \cdot 2 \cdot 2 \cdot 2 \cdot 2 \cdot 2 \cdot 2}_{2^9} = 1536$.

4. First, change 2 into a fraction, or $\frac{2}{1}$. So, the pattern is now $\frac{2}{1}, \frac{3}{4}, \frac{4}{9}, \frac{5}{16}, \frac{6}{25} \dots$. The top is 2, 3, 4, 5, 6. It increases by 1 each time, so the 8^{th} term's numerator is 9. The denominators are the square numbers, so the 8^{th} term's denominator is 8^2 or 64. The 8^{th} term is $\frac{9}{64}$.

Practice

For questions 1-3, determine how many dots there would be in the 4^{th} and the 10^{th} pattern of each figure below.

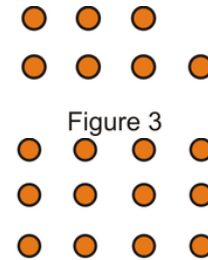
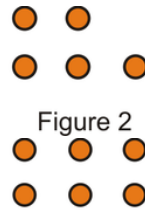
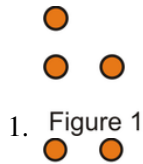

2. Figure 1

Figure 2

Figure 3

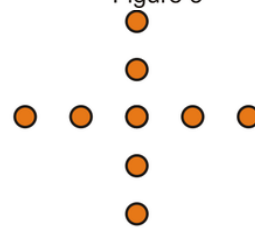

3. Figure 1

Figure 2

Figure 3

4. Use the pattern below to answer the questions.

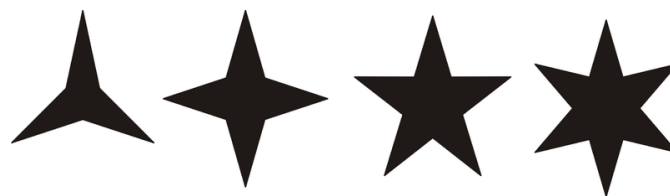

- a. Draw the next figure in the pattern.
- b. How does the number of points in each star relate to the figure number?

5. Use the pattern below to answer the questions. All the triangles are equilateral triangles.

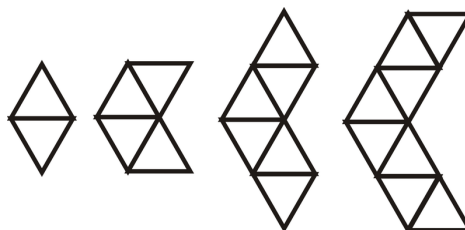

- a. Draw the next figure in the pattern. How many triangles does it have?
- b. Determine how many triangles are in the 24^{th} figure.

For questions 6-13, determine: the next three terms in the pattern.

6. 5, 8, 11, 14, 17, ...
7. 6, 1, -4, -9, -14, ...
8. 2, 4, 8, 16, 32, ...
9. 67, 56, 45, 34, 23, ...
10. 9, -4, 6, -8, 3, ...
11. $\frac{1}{2}, \frac{2}{3}, \frac{3}{4}, \frac{4}{5}, \frac{5}{6}, \dots$
12. $\frac{2}{3}, \frac{4}{7}, \frac{6}{11}, \frac{8}{15}, \frac{10}{19}, \dots$
13. -1, 5, -9, 13, -17, ...

For questions 14-17, determine the next two terms **and** describe the pattern.

14. 3, 6, 11, 18, 27, ...
15. 3, 8, 15, 24, 35, ...
16. 1, 8, 27, 64, 125, ...
17. 1, 1, 2, 3, 5, ...

2.2 Deductive Reasoning

Here you'll learn how to deductively draw conclusions from given facts.

What if you were given a fact like "If you are late for class, you will get a detention"? What conclusions could you draw from this fact? After completing this concept, you'll be able to use deductive reasoning laws to make logical conclusions.

Watch This



MEDIA

Click image to the left for more content.

CK-12 Types of Reasoning: Deductive

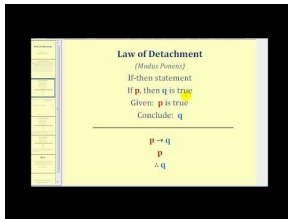

MEDIA

Click image to the left for more content.

James Sousa: Introduction to Deductive Reasoning

Guidance

Deductive reasoning entails drawing conclusion from facts. When using deductive reasoning there are a few laws that are helpful to know.

Law of Detachment: If $p \rightarrow q$ is true, and p is true, then q is true. See the example below.

Here are two true statements:

1. *If a number is odd (p), then it is the sum of an even and odd number (q).*
2. *5 is an odd number (a specific example of p).*

The conclusion must be that *5 is the sum of an even and an odd number (q).*

Law of Contrapositive: If $p \rightarrow q$ is true and $\sim q$ is true, then you can conclude $\sim p$. See the example below.

Here are two true statements:

1. *If a student is in Geometry (p), then he or she has passed Algebra I (q).*
2. *Daniel has not passed Algebra I (a specific example of $\sim q$).*

The conclusion must be that *Daniel is not in Geometry* (p).

Law of Syllogism: If $p \rightarrow q$ and $q \rightarrow r$ are true, then $p \rightarrow r$ is true. See the example below.

Here are three true statements:

1. *If Pete is late* (p), *Mark will be late* (q).
2. *If Mark is late* (q), *Karl will be late* (r).
3. *Pete is late* (p).

Notice how each “then” becomes the next “if” in a chain of statements. If Pete is late, this starts a domino effect of lateness. Mark will be late and Karl will be late too. So, if Pete is late, then *Karl will be late* (r), is the logical conclusion.

Example A

Suppose Bea makes the following statements, which are known to be true.

If Central High School wins today, they will go to the regional tournament. Central High School won today.

What is the logical conclusion?

These are true statements that we can take as facts. The conclusion is: *Central High School will go to the regional tournament.*

Example B

Here are two true statements.

If $\angle A$ and $\angle B$ are a linear pair, then $m\angle A + m\angle B = 180^\circ$.

$\angle ABC$ and $\angle CBD$ are a linear pair.

What conclusion can you draw from this?

This is an example of the Law of Detachment, therefore:

$$m\angle ABC + m\angle CBD = 180^\circ$$

Example C

Determine the conclusion from the true statements below.

Babies wear diapers.

My little brother does not wear diapers.

The second statement is the equivalent of $\sim q$. Therefore, the conclusion is $\sim p$, or: *My little brother is not a baby.*



MEDIA

Click image to the left for more content.

Guided Practice

1. Here are two true statements.

If $\angle A$ and $\angle B$ are a linear pair, then $m\angle A + m\angle B = 180^\circ$.

$m\angle 1 = 90^\circ$ and $m\angle 2 = 90^\circ$.

What conclusion can you draw from these two statements?

2. Determine the conclusion from the true statements below.

If you are not in Chicago, then you can't be on the L.

Bill is in Chicago.

3. Determine the conclusion from the true statements below.

If you are not in Chicago, then you can't be on the L.

Sally is on the L.

Answers:

1. Here there is NO conclusion. These statements are in the form:

$$p \rightarrow q$$

$$q$$

We **cannot** conclude that $\angle 1$ and $\angle 2$ are a linear pair.

Here are two counterexamples:

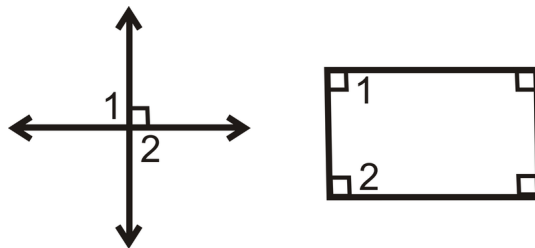

2. If we were to rewrite this symbolically, it would look like:

$$\sim p \rightarrow \sim q$$

$$p$$

This is not in the form of the Law of Contrapositive or the Law of Detachment, so neither of these laws can be used to draw a logical conclusion.

3. If we were to rewrite this symbolically, it would look like:

$$\sim p \rightarrow \sim q$$

$$q$$

Even though it looks a little different, this is an example of the Law of Contrapositive. Therefore, the logical conclusion is: *Sally is in Chicago.*

Practice

Determine the logical conclusion and state which law you used (Law of Detachment, Law of Contrapositive, or Law of Syllogism). If no conclusion can be drawn, write “no conclusion.”

1. People who vote for Jane Wannabe are smart people. I voted for Jane Wannabe.
2. If Rae is the driver today then Maria is the driver tomorrow. Ann is the driver today.
3. All equiangular triangles are equilateral. $\triangle ABC$ is equiangular.
4. If North wins, then West wins. If West wins, then East loses.
5. If $z > 5$, then $x > 3$. If $x > 3$, then $y > 7$.
6. If I am cold, then I wear a jacket. I am not wearing a jacket.
7. If it is raining outside, then I need an umbrella. It is not raining outside.
8. If a shape is a circle, then it never ends. If it never ends, then it never starts. If it never starts, then it doesn't exist. If it doesn't exist, then we don't need to study it.
9. If you text while driving, then you are unsafe. You are a safe driver.
10. If you wear sunglasses, then it is sunny outside. You are wearing sunglasses.
11. If you wear sunglasses, then it is sunny outside. It is cloudy.
12. I will clean my room if my mom asks me to. I am not cleaning my room.
13. Write the symbolic representation of #8. Include your conclusion. Does this argument make sense?
14. Write the symbolic representation of #10. Include your conclusion.
15. Write the symbolic representation of #11. Include your conclusion.

2.3 If-Then Statements

Here you'll learn about conditional statements and how to rewrite statements in if-then form.

What if you were given a statement like "All squares are rectangles"? How could you determine the hypothesis and conclusion of this statement? After completing this Concept, you'll be able to rewrite statements in if-then, or conditional, form.

Watch This



MEDIA

Click image to the left for more content.

CK-12 If-Then Statements

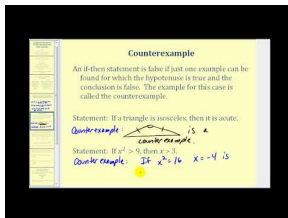

MEDIA

Click image to the left for more content.

James Sousa:If-ThenStatements and Converses

Guidance

A **conditional statement** (also called an **if-then statement**) is a statement with a hypothesis followed by a conclusion. The **hypothesis** is the first, or “if,” part of a conditional statement. The **conclusion** is the second, or “then,” part of a conditional statement. The conclusion is the result of a hypothesis.

If this happens, then that will happen.
hypothesis conclusion

If-then statements might not always be written in the “if-then” form. Here are some examples of conditional statements:

- **Statement 1:** If you work overtime, then you'll be paid time-and-a-half.
- **Statement 2:** I'll wash the car if the weather is nice.
- **Statement 3:** If 2 divides evenly into x , then x is an even number.
- **Statement 4:** I'll be a millionaire when I win the lottery.

- **Statement 5:** All equiangular triangles are equilateral.

Statements 1 and 3 are written in the “if-then” form. The hypothesis of Statement 1 is “you work overtime.” The conclusion is “you’ll be paid time-and-a-half.” **Statement 2** has the hypothesis after the conclusion. If the word “if” is in the middle of the statement, then the hypothesis is after it. The statement can be rewritten: *If the weather is nice, then I will wash the car.* **Statement 4** uses the word “when” instead of “if” and is like Statement 2. It can be written: *If I win the lottery, then I will be a millionaire.* **Statement 5** “if” and “then” are not there. It can be rewritten: *If a triangle is equiangular, then it is equilateral.*

Example A

Use the statement: *I will graduate when I pass Calculus.*

- Rewrite in if-then form.
- Determine the hypothesis and conclusion.

This statement can be rewritten as *If I pass Calculus, then I will graduate.* The hypothesis is “I pass Calculus,” and the conclusion is “I will graduate.”

Example B

Use the statement: *All prime numbers are odd.*

- Rewrite in if-then form.
- Determine the hypothesis and conclusion.
- Is this a true statement?

This statement can be rewritten as *If a number is prime, then it is odd.* The hypothesis is “a number is prime” and the conclusion is “it is odd”. This is not a true statement (remember that not all conditional statements will be true!) since 2 is a prime number but it is not odd.

Example C

Determine the hypothesis and conclusion: Sarah will go to the store if Riley does the laundry.

The statement can be rewritten as “If Riley does the laundry then Sarah will go to the store.” The hypothesis is “Riley does the laundry” and the conclusion is “Sarah will go to the store.”



MEDIA

Click image to the left for more content.

[CK-12 If-Then Statements](#)

Guided Practice

Determine the hypothesis and conclusion:

1. I’ll bring an umbrella if it rains.

2. If I win the game, then I will get a prize.
3. All right angles are 90° .

Answers:

1. Hypothesis: "It rains." Conclusion: "I'll bring an umbrella."
2. Hypothesis: "I win the game." Conclusion: "I will get a prize."
3. Hypothesis: "An angle is right." Conclusion: "It is 90° ."

Practice

Determine the hypothesis and the conclusion for each statement.

1. If 5 divides evenly into x , then x ends in 0 or 5.
2. If a triangle has three congruent sides, it is an equilateral triangle.
3. Three points are coplanar if they all lie in the same plane.
4. If $x = 3$, then $x^2 = 9$.
5. If you take yoga, then you are relaxed.
6. All baseball players wear hats.
7. I'll learn how to drive when I am 16 years old.
8. If you do your homework, then you can watch TV.
9. Alternate interior angles are congruent if lines are parallel.
10. All kids like ice cream.

2.4 Converse, Inverse, and Contrapositive

Here you'll learn how to write the converse, inverse, and contrapositive of any conditional statement. You'll also learn what a biconditional statement is.

What if you were given a conditional statement like "If I walk to school, then I will be late"? How could you rearrange and/or negate this statement to form new conditional statements? After completing this Concept, you'll be able to write the converse, inverse, and contrapositive of a conditional statement like this one.

Watch This



MEDIA

Click image to the left for more content.

CK-12 Converse, Inverse and Contrapositive of a Conditional Statement

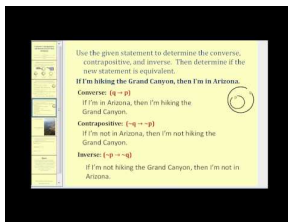

MEDIA

Click image to the left for more content.

James Sousa:Converse, Contrapositive, and Inverse of anIf-ThenStatement

Guidance

Consider the statement: *If the weather is nice, then I'll wash the car.* We can rewrite this statement using letters to represent the hypothesis and conclusion.

p = the weather is nice

q = I'll wash the car

Now the statement is: If p , then q , which can also be written as $p \rightarrow q$.

We can also make the negations, or "nots," of p and q . The symbolic version of "not p " is $\sim p$.

$\sim p$ = the weather is not nice

$\sim q$ = I won't wash the car

Using these "nots" and switching the order of p and q , we can create three new statements.

Converse	$q \rightarrow p$	<u>If I wash the car,</u> <u>then the weather is nice.</u> $\underbrace{\hspace{10em}}_q \quad \underbrace{\hspace{10em}}_p$
Inverse	$\sim p \rightarrow \sim q$	<u>If the weather is not nice,</u> <u>then I won't wash the car.</u> $\underbrace{\hspace{10em}}_{\sim p} \quad \underbrace{\hspace{10em}}_{\sim q}$
Contrapositive	$\sim q \rightarrow \sim p$	<u>If I don't wash the car,</u> <u>then the weather is not nice.</u> $\underbrace{\hspace{10em}}_{\sim q} \quad \underbrace{\hspace{10em}}_{\sim p}$

If the “if-then” statement is true, then the contrapositive is also true. The contrapositive is **logically equivalent** to the original statement. The converse and inverse may or may not be true. When the original statement and converse are both true then the statement is a **biconditional statement**. In other words, if $p \rightarrow q$ is true and $q \rightarrow p$ is true, then $p \leftrightarrow q$ (said “ p if and only if q ”).

Example A

If $n > 2$, then $n^2 > 4$.

a) Find the converse, inverse, and contrapositive.

b) Determine if the statements from part a are true or false. If they are false, find a counterexample.

The original statement is true.

Converse : If $n^2 > 4$, then $n > 2$. *False*. If $n^2 = 9$, $n = -3$ or 3 . $(-3)^2 = 9$

Inverse : If $n \leq 2$, then $n^2 \leq 4$. *False*. If $n = -3$, then $n^2 = 9$.

Contrapositive : If $n^2 \leq 4$, then $n \leq 2$. *True*. The only $n^2 \leq 4$ is 1 or 4. $\sqrt{1} = \pm 1$

and $\sqrt{4} = \pm 2$

, which are both less than or equal to 2.

Example B

If I am at Disneyland, then I am in California.

a) Find the converse, inverse, and contrapositive.

b) Determine if the statements from part a are true or false. If they are false, find a counterexample.

The original statement is true.

Converse : If I am in California, then I am at Disneyland.

False. I could be in San Francisco.

Inverse : If I am not at Disneyland, then I am not in California.

False. Again, I could be in San Francisco.

Contrapositive : If I am not in California, then I am not at Disneyland.

True. If I am not in the state, I couldn't be at Disneyland.

Notice for the converse and inverse **we can use the same counterexample**.

Example C

Rewrite as a biconditional statement: Any two points are collinear.

This statement can be rewritten as:

Two points are on the same line if and only if they are collinear. Replace the “if-then” with “if and only if” in the middle of the statement.



MEDIA

Click image to the left for more content.

CK-12 Converse, Inverse and Contrapositive of a Conditional Statement

Guided Practice

- Any two points are collinear.
 - Find the converse, inverse, and contrapositive.
 - Determine if the statements from part a are true or false. If they are false, find a counterexample.

2. The following is a true statement:

$m\angle ABC > 90^\circ$ if and only if $\angle ABC$ is an obtuse angle.

Determine the two true statements within this biconditional.

3. $p : x < 10$ $q : 2x < 50$

- Is $p \rightarrow q$ true? If not, find a counterexample.
- Is $q \rightarrow p$ true? If not, find a counterexample.
- Is $\sim p \rightarrow \sim q$ true? If not, find a counterexample.
- Is $\sim q \rightarrow \sim p$ true? If not, find a counterexample.

Answers

1. First, change the statement into an “if-then” statement:

If two points are on the same line, then they are collinear.

<u>Converse</u> :	If two points are collinear, then they are on the same line. <i>True.</i>
<u>Inverse</u> :	If two points are not on the same line, then they are not collinear. <i>True.</i>
<u>Contrapositive</u> :	If two points are not collinear, then they do not lie on the same line. <i>True.</i>

2. *Statement 1:* If $m\angle ABC > 90^\circ$, then $\angle ABC$ is an obtuse angle.

Statement 2: If $\angle ABC$ is an obtuse angle, then $m\angle ABC > 90^\circ$.

- If $x < 10$, then $2x < 50$. **True.**
 - If $2x < 50$, then $x < 10$. **False**, $x = 15$
 - If $x \geq 10$, then $2x \geq 50$. **False**, $x = 15$
 - If $2x \geq 50$, then $x \geq 10$. **True**, $x \geq 25$

Practice

For questions 1-4, use the statement:

If $AB = 5$ and $BC = 5$, then B is the midpoint of \overline{AC} .

1. Is this a true statement? If not, what is a counterexample?
2. Find the converse of this statement. Is it true?
3. Find the inverse of this statement. Is it true?
4. Find the contrapositive of this statement. Which statement is it the same as?

Find the converse of each true if-then statement. If the converse is true, write the biconditional statement.

5. An acute angle is less than 90° .
6. If you are at the beach, then you are sun burnt.
7. If $x > 4$, then $x + 3 > 7$.

For questions 8-10, determine the two true conditional statements from the given biconditional statements.

8. A U.S. citizen can vote if and only if he or she is 18 or more years old.
9. A whole number is prime if and only if its factors are 1 and itself.
10. $2x = 18$ if and only if $x = 9$.

2.5 Conjectures and Counterexamples

Here you'll learn how to make educated guesses, or conjectures, based on patterns. You'll also learn how to disprove conjectures with counterexamples.

Suppose you were given a mathematical pattern like $h = -16/t^2$. What if you wanted to make an educated guess, or conjecture, about h ? After completing this Concept, you'll be able to make such a guess and provide counterexamples that disprove incorrect guesses.

Watch This



MEDIA

Click image to the left for more content.

CK-12 Conjectures and Counterexamples

Watch the final part of this video.

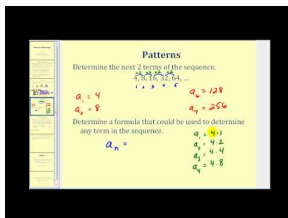

MEDIA

Click image to the left for more content.

James Sousa:Counterexamples

Guidance

A **conjecture** is an “educated guess” that is based on examples in a pattern. A **counterexample** is an example that disproves a conjecture.

Example A

Here's an algebraic equation and a table of values for n and t .

$$t = (n - 1)(n - 2)(n - 3)$$

TABLE 2.1:

n	$(n-1)(n-2)(n-3)$	t
1	$(0)(-1)(-2)$	0
2	$(1)(0)(-1)$	0
3	$(2)(1)(0)$	0

After looking at the table, Pablo makes this conjecture:

The value of $(n-1)(n-2)(n-3)$ is 0 for any number n .

Is this a true conjecture?

This is not a valid conjecture. If Pablo were to continue the table to $n = 4$, he would have seen that $(n-1)(n-2)(n-3) = (4-1)(4-2)(4-3) = (3)(2)(1) = 6$

In this example $n = 4$ is the counterexample.

Example B

Arthur is making figures for an art project. He drew polygons and some of their diagonals.

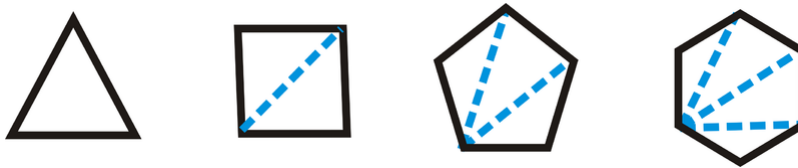

From these examples, Arthur made this conjecture:

If a convex polygon has n sides, then there are $n - 2$ triangles formed when diagonals are drawn from any vertex of the polygon.

Is Arthur's conjecture correct? Or, can you find a counterexample?

The conjecture appears to be correct. If Arthur draws other polygons, in every case he will be able to draw $n - 2$ triangles if the polygon has n sides.

*Notice that we have **not proved** Arthur's conjecture, but only found several examples that hold true. So, at this point, we say that the conjecture is true.*

Example C

Give a counterexample to this statement: Every prime number is an odd number.

The only counterexample is the number 2: an even number (not odd) that is prime.



MEDIA

Click image to the left for more content.

Guided Practice

A car salesman sold 5 used cars to five different couples. He noticed that each couple was under 30 years old. The following day, he sold a new, luxury car to a couple in their 60's. The salesman determined that only younger couples buy used cars.

1. Is the salesman's conjecture logical? Why or why not?
2. Can you think of a counterexample?

Answers:

1. It is logical based on his experiences, but is not true.
2. A counterexample would be a couple that is 30 years old or older buying a used car.

Practice

Give a counterexample for each of the following statements.

1. If n is a whole number, then $n^2 > n$.
2. All numbers that end in 1 are prime numbers.
3. All positive fractions are between 0 and 1.
4. Any three points that are coplanar are also collinear.
5. All girls like ice cream.
6. All high school students are in choir.
7. For any angle there exists a complementary angle.
8. All teenagers can drive.
9. If n is an integer, then $n > 0$.
10. All equations have integer solutions.

2.6 Properties of Equality and Congruence

Here you'll review the properties of equality you learned in Algebra I, be introduced to the properties of congruence, and learn how to use these properties.

Suppose you know that a circle measures 360 degrees and you want to find what kind of angle one-quarter of a circle is. After completing this Concept, you'll be able to apply the basic properties of equality and congruence to solve geometry problems like this one.

Watch This



MEDIA

Click image to the left for more content.

CK-12 Properties of Equality and Congruence

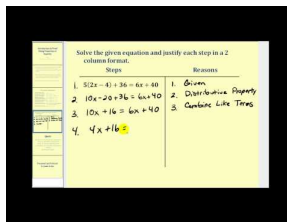

MEDIA

Click image to the left for more content.

James Sousa: Introduction to Proof Using Properties of Equality

Now watch this.

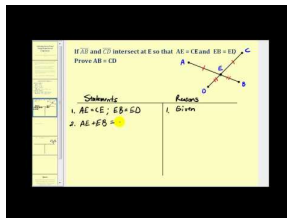

MEDIA

Click image to the left for more content.

James Sousa: Introduction to Proof Using Properties of Congruence

Guidance

The basic properties of equality were introduced to you in Algebra I. Here they are again:

- **Reflexive Property of Equality:** $AB = AB$

- **Symmetric Property of Equality:** If $m\angle A = m\angle B$, then $m\angle B = m\angle A$
- **Transitive Property of Equality:** If $AB = CD$ and $CD = EF$, then $AB = EF$
- **Substitution Property of Equality:** If $a = 9$ and $a - c = 5$, then $9 - c = 5$
- **Addition Property of Equality:** If $2x = 6$, then $2x + 5 = 6 + 5$ or $2x + 5 = 11$
- **Subtraction Property of Equality:** If $m\angle x + 15^\circ = 65^\circ$, then $m\angle x + 15^\circ - 15^\circ = 65^\circ - 15^\circ$ or $m\angle x = 50^\circ$
- **Multiplication Property of Equality:** If $y = 8$, then $5 \cdot y = 5 \cdot 8$ or $5y = 40$
- **Division Property of Equality:** If $3b = 18$, then $\frac{3b}{3} = \frac{18}{3}$ or $b = 6$
- **Distributive Property:** $5(2x - 7) = 5(2x) - 5(7) = 10x - 35$

Just like the properties of equality, there are properties of congruence. These properties hold for figures and shapes.

- **Reflexive Property of Congruence:** $\overline{AB} \cong \overline{AB}$ or $\angle B \cong \angle B$
- **Symmetric Property of Congruence:** If $\overline{AB} \cong \overline{CD}$, then $\overline{CD} \cong \overline{AB}$. Or, if $\angle ABC \cong \angle DEF$, then $\angle DEF \cong \angle ABC$
- **Transitive Property of Congruence:** If $\overline{AB} \cong \overline{CD}$ and $\overline{CD} \cong \overline{EF}$, then $\overline{AB} \cong \overline{EF}$. Or, if $\angle ABC \cong \angle DEF$ and $\angle DEF \cong \angle GHI$, then $\angle ABC \cong \angle GHI$

When you solve equations in algebra you use properties of equality. You might not write out the property for each step, but you should know that there is an equality property that justifies that step. We will abbreviate “Property of Equality” “*PoE*” and “Property of Congruence” “*PoC*” when we use these properties in proofs.

Example A

Solve $2(3x - 4) + 11 = x - 27$ and write the property for each step (also called “to justify each step”).

$2(3x - 4) + 11 = x - 27$	
$6x - 8 + 11 = x - 27$	Distributive Property
$6x + 3 = x - 27$	Combine like terms
$6x + 3 - 3 = x - 27 - 3$	Subtraction <i>PoE</i>
$6x = x - 30$	Simplify
$6x - x = x - x - 30$	Subtraction <i>PoE</i>
$5x = -30$	Simplify
$\frac{5x}{5} = \frac{-30}{5}$	Division <i>PoE</i>
$x = -6$	Simplify

Example B

$AB = 8$, $BC = 17$, and $AC = 20$. Are points A , B , and C collinear?

Set up an equation using the Segment Addition Postulate.

$AB + BC = AC$	Segment Addition Postulate
$8 + 17 = 20$	Substitution <i>PoE</i>
$25 \neq 20$	Combine like terms

Because the two sides of the equation are not equal, A , B and C are not collinear.

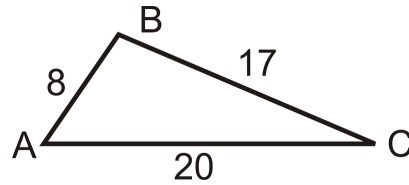
**Example C**

If $m\angle A + m\angle B = 100^\circ$ and $m\angle B = 40^\circ$, prove that $m\angle A$ is an acute angle.

We will use a 2-column format, with statements in one column and their reasons next to it, just like Example A.

$m\angle A + m\angle B = 100^\circ$	Given Information
$m\angle B = 40^\circ$	Given Information
$m\angle A + 40^\circ = 100^\circ$	Substitution <i>PoE</i>
$m\angle A = 60^\circ$	Subtraction <i>PoE</i>
$\angle A$ is an acute angle	Definition of an acute angle, $m\angle A < 90^\circ$



MEDIA

Click image to the left for more content.

CK-12 Properties of Equality and Congruence

Guided Practice

Use the given property or properties of equality to fill in the blank. x , y , and z are real numbers.

- Symmetric: If $x = 3$, then _____.
- Distributive: If $4(3x - 8)$, then _____.
- Transitive: If $y = 12$ and $x = y$, then _____.

Answers:

- $3 = x$
- $12x - 32$
- $x = 12$

Practice

For questions 1-8, solve each equation and justify each step.

- $3x + 11 = -16$
- $7x - 3 = 3x - 35$

3. $\frac{2}{3}g + 1 = 19$

4. $\frac{1}{2}MN = 5$

5. $5m\angle ABC = 540^\circ$

6. $10b - 2(b + 3) = 5b$

7. $\frac{1}{4}y + \frac{5}{6} = \frac{1}{3}$

8. $\frac{1}{4}AB + \frac{1}{3}AB = 12 + \frac{1}{2}AB$

For questions 9-11, use the given property or properties of equality to fill in the blank. x , y , and z are real numbers.

9. Symmetric: If $x + y = y + z$, then _____.
10. Transitive: If $AB = 5$ and $AB = CD$, then _____.
11. Substitution: If $x = y - 7$ and $x = z + 4$, then _____.

2.7 Two-Column Proofs

Here you'll learn how to create two-column proofs with statements and reasons for each step you take in proving a geometric statement.

Suppose you are told that $\angle XYZ$ is a right angle and that \overrightarrow{YW} bisects $\angle XYZ$. You are then asked to prove $\angle XYW \cong \angle WYZ$. After completing this Concept, you'll be able to create a two-column proof to prove this congruency.

Watch This



MEDIA

Click image to the left for more content.

CK-12 Two Column Proofs

Guidance

A **two column proof** is one common way to organize a proof in geometry. Two column proofs always have two columns- statements and reasons. The best way to understand two column proofs is to read through examples.

When writing your own two column proof, keep these things in mind:

- **Number each step.**
- **Start with the given information.**
- **Statements with the same reason can be combined into one step.** It is up to you.
- **Draw a picture and mark it with the given information.**
- **You must have a reason for EVERY statement.**
- **The order of the statements in the proof is not always fixed, but make sure the order makes logical sense.**
- **Reasons will be definitions, postulates, properties and previously proven theorems.** “Given” is only used as a reason if the information in the statement column was told in the problem.
- **Use symbols and abbreviations for words within proofs.** For example, \cong can be used in place of the word *congruent*. You could also use \angle for the word *angle*.

Example A

Write a two-column proof for the following:

If $A, B, C,$ and D are points on a line, in the given order, and $AB = CD$, then $AC = BD$.

When the statement is given in this way, the “if” part is the given and the “then” part is what we are trying to prove.

Always start with drawing a picture of what you are given.

Plot the points in the order A, B, C, D on a line.



Add the given, $AB = CD$.



Draw the 2-column proof and start with the given information.

TABLE 2.2:

<i>Statement</i>	<i>Reason</i>
1. $A, B, C,$ and D are collinear, in that order.	1. Given
2. $AB = CD$	2. Given
3. $BC = BC$	3. Reflexive <i>PoE</i>
4. $AB + BC = BC + CD$	4. Addition <i>PoE</i>
5. $AB + BC = AC$ $BC + CD = BD$	5. Segment Addition Postulate
6. $AC = BD$	6. Substitution or Transitive <i>PoE</i>

Example B

Write a two-column proof.

Given: \overrightarrow{BF} bisects $\angle ABC$; $\angle ABD \cong \angle CBE$

Prove: $\angle DBF \cong \angle EBF$

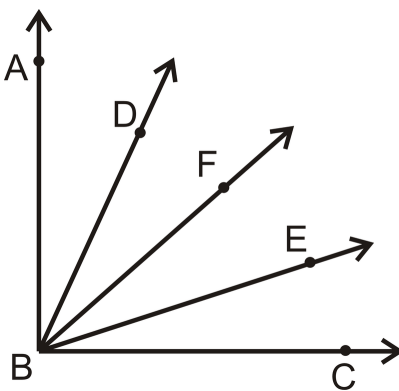

First, put the appropriate markings on the picture. Recall, that bisect means “to cut in half.” Therefore, $m\angle ABF = m\angle FBC$.

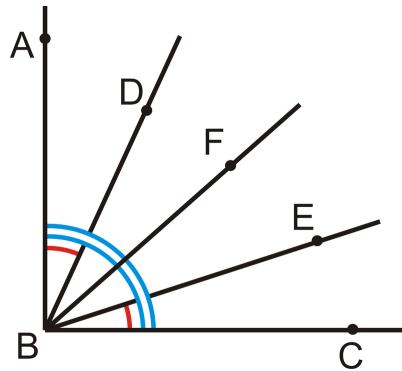

TABLE 2.3:

<i>Statement</i>	<i>Reason</i>
1. \overrightarrow{BF} bisects $\angle ABC$, $\angle ABD \cong \angle CBE$	1. Given
2. $m\angle ABF = m\angle FBC$	2. Definition of an Angle Bisector
3. $m\angle ABD = m\angle CBE$	3. If angles are \cong , then their measures are equal.
4. $m\angle ABF = m\angle ABD + m\angle DBF$ $m\angle FBC = m\angle EBF + m\angle CBE$	4. Angle Addition Postulate
5. $m\angle ABD + m\angle DBF = m\angle EBF + m\angle CBE$	5. Substitution <i>PoE</i>
6. $m\angle ABD + m\angle DBF = m\angle EBF + m\angle ABD$	6. Substitution <i>PoE</i>
7. $m\angle DBF = m\angle EBF$	7. Subtraction <i>PoE</i>
8. $\angle DBF \cong \angle EBF$	8. If measures are equal, the angles are \cong .

Example C

The **Right Angle Theorem** states that if two angles are right angles, then the angles are congruent. Prove this theorem.

To prove this theorem, set up your own drawing and name some angles so that you have specific angles to talk about.

Given: $\angle A$ and $\angle B$ are right angles

Prove: $\angle A \cong \angle B$

TABLE 2.4:

<i>Statement</i>	<i>Reason</i>
1. $\angle A$ and $\angle B$ are right angles	1. Given
2. $m\angle A = 90^\circ$ and $m\angle B = 90^\circ$	2. Definition of right angles
3. $m\angle A = m\angle B$	3. Transitive <i>PoE</i>
4. $\angle A \cong \angle B$	4. \cong angles have = measures

Any time right angles are mentioned in a proof, you will need to use this theorem to say the angles are congruent.

Example D

The **Same Angle Supplements Theorem** states that if two angles are supplementary to the same angle then the two angles are congruent. Prove this theorem.

Given: $\angle A$ and $\angle B$ are supplementary angles. $\angle B$ and $\angle C$ are supplementary angles.

Prove: $\angle A \cong \angle C$

TABLE 2.5:

<i>Statement</i>	<i>Reason</i>
1. $\angle A$ and $\angle B$ are supplementary $\angle B$ and $\angle C$ are supplementary	1. Given
2. $m\angle A + m\angle B = 180^\circ$ $m\angle B + m\angle C = 180^\circ$	2. Definition of supplementary angles
3. $m\angle A + m\angle B = m\angle B + m\angle C$	3. Substitution <i>PoE</i>
4. $m\angle A = m\angle C$	4. Subtraction <i>PoE</i>
5. $\angle A \cong \angle C$	5. \cong angles have = measures

Example E

The **Vertical Angles Theorem** states that vertical angles are congruent. Prove this theorem.

Given: Lines k and m intersect.

Prove: $\angle 1 \cong \angle 3$

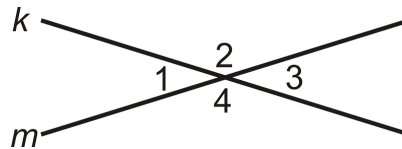

TABLE 2.6:

<i>Statement</i>	<i>Reason</i>
1. Lines k and m intersect	1. Given
2. $\angle 1$ and $\angle 2$ are a linear pair $\angle 2$ and $\angle 3$ are a linear pair	2. Definition of a Linear Pair
3. $\angle 1$ and $\angle 2$ are supplementary $\angle 2$ and $\angle 3$ are supplementary	3. Linear Pair Postulate
4. $m\angle 1 + m\angle 2 = 180^\circ$ $m\angle 2 + m\angle 3 = 180^\circ$	4. Definition of Supplementary Angles
5. $m\angle 1 + m\angle 2 = m\angle 2 + m\angle 3$	5. Substitution <i>PoE</i>
6. $m\angle 1 = m\angle 3$	6. Subtraction <i>PoE</i>
7. $\angle 1 \cong \angle 3$	7. \cong angles have = measures

Guided Practice

1. $\angle 1 \cong \angle 4$ and $\angle C$ and $\angle F$ are right angles.

Which angles are congruent and why?

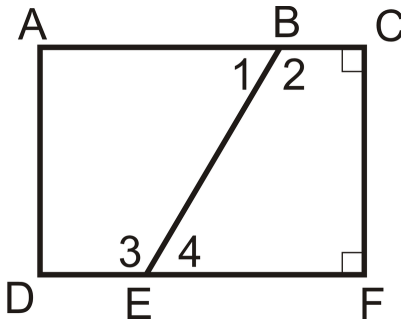

2. In the figure $\angle 2 \cong \angle 3$ and $k \perp p$.

Each pair below is congruent. State why.

- $\angle 1$ and $\angle 5$
- $\angle 1$ and $\angle 4$
- $\angle 2$ and $\angle 6$
- $\angle 6$ and $\angle 7$

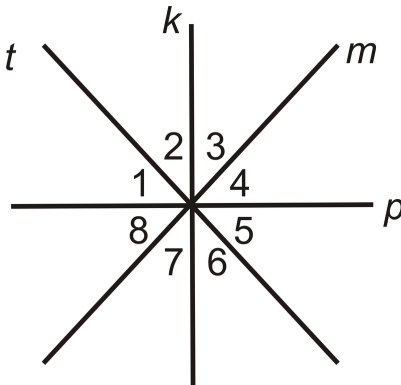

3. Write a two-column proof.

Given: $\angle 1 \cong \angle 2$ and $\angle 3 \cong \angle 4$

Prove: $\angle 1 \cong \angle 4$

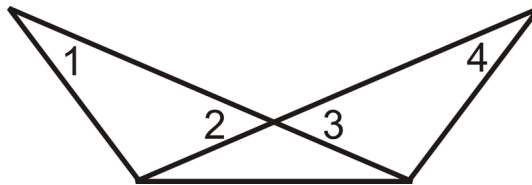

Answers:

1. By the Right Angle Theorem, $\angle C \cong \angle F$. Also, $\angle 2 \cong \angle 3$ by the Same Angles Supplements Theorem because $\angle 1 \cong \angle 4$ and they are linear pairs with these congruent angles.

2. a) Vertical Angles Theorem

b) Same Angles Complements Theorem

c) Vertical Angles Theorem

d) Vertical Angles Theorem followed by the Transitive Property

3. Follow the format from the examples.

TABLE 2.7:

<i>Statement</i>	<i>Reason</i>
1. $\angle 1 \cong \angle 2$ and $\angle 3 \cong \angle 4$	1. Given
2. $\angle 2 \cong \angle 3$	2. Vertical Angles Theorem
3. $\angle 1 \cong \angle 4$	3. Transitive <i>PoC</i>

Practice

Fill in the blanks in the proofs below.

1. Given: $\angle ABC \cong \angle DEF$ and $\angle GHI \cong \angle JKL$

Prove: $m\angle ABC + m\angle GHI = m\angle DEF + m\angle JKL$

TABLE 2.8:

<i>Statement</i>	<i>Reason</i>
1.	1. Given
2. $m\angle ABC = m\angle DEF$ $m\angle GHI = m\angle JKL$	2.
3.	3. Addition <i>PoE</i>
4. $m\angle ABC + m\angle GHI = m\angle DEF + m\angle JKL$	4.

2. Given: M is the midpoint of \overline{AN} . N is the midpoint \overline{MB}

Prove: $AM = NB$

TABLE 2.9:

<i>Statement</i>	<i>Reason</i>
1.	Given
2.	Definition of a midpoint
3. $AM = NB$	

3. Given: $\overline{AC} \perp \overline{BD}$ and $\angle 1 \cong \angle 4$

Prove: $\angle 2 \cong \angle 3$

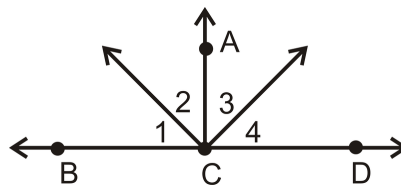

TABLE 2.10:

<i>Statement</i>	<i>Reason</i>
1. $\overline{AC} \perp \overline{BD}$, $\angle 1 \cong \angle 4$	1.
2. $m\angle 1 = m\angle 4$	2.
3.	3. \perp lines create right angles
4. $m\angle ACB = 90^\circ$ $m\angle ACD = 90^\circ$	4.

TABLE 2.10: (continued)

<i>Statement</i>	<i>Reason</i>
5. $m\angle 1 + m\angle 2 = m\angle ACB$ $m\angle 3 + m\angle 4 = m\angle ACD$	5.
6.	6. Substitution
7. $m\angle 1 + m\angle 2 = m\angle 3 + m\angle 4$	7.
8.	8. Substitution
9.	9. Subtraction <i>PoE</i>
10. $\angle 2 \cong \angle 3$	10.

4. Given: $\angle MLN \cong \angle OLP$

Prove: $\angle MLO \cong \angle NLP$

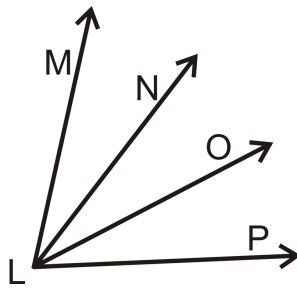

TABLE 2.11:

<i>Statement</i>	<i>Reason</i>
1.	1.
2.	2. \cong angles have = measures
3.	3. Angle Addition Postulate
4.	4. Substitution
5. $m\angle MLO = m\angle NLP$	5.
6.	6. \cong angles have = measures

5. Given: $\overline{AE} \perp \overline{EC}$ and $\overline{BE} \perp \overline{ED}$

Prove: $\angle 1 \cong \angle 3$

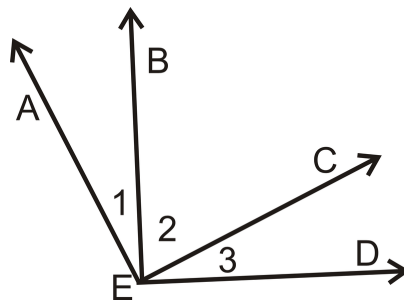

TABLE 2.12:

<i>Statement</i>	<i>Reason</i>
1.	1.

TABLE 2.12: (continued)

<i>Statement</i>	<i>Reason</i>
2.	2. \perp lines create right angles
3. $m\angle BED = 90^\circ$ $m\angle AEC = 90^\circ$	3.
4.	4. Angle Addition Postulate
5.	5. Substitution
6. $m\angle 2 + m\angle 3 = m\angle 1 + m\angle 3$	6.
7.	7. Subtraction <i>PoE</i>
8.	8. \cong angles have = measures

6. Given: $\angle L$ is supplementary to $\angle M$ and $\angle P$ is supplementary to $\angle O$ and $\angle L \cong \angle O$

Prove: $\angle P \cong \angle M$

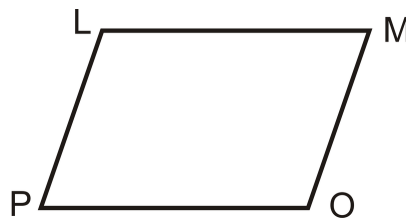

TABLE 2.13:

<i>Statement</i>	<i>Reason</i>
1.	1.
2. $m\angle L = m\angle O$	2.
3.	3. Definition of supplementary angles
4.	4. Substitution
5.	5. Substitution
6.	6. Subtraction <i>PoE</i>
7. $\angle M \cong \angle P$	7.

7. Given: $\angle 1 \cong \angle 4$

Prove: $\angle 2 \cong \angle 3$

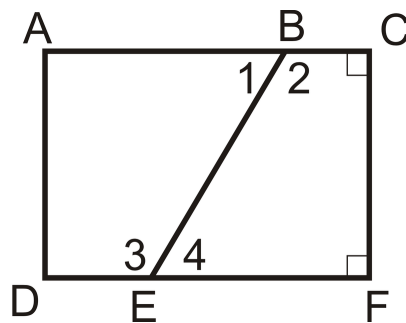

TABLE 2.14:

<i>Statement</i>	<i>Reason</i>
1.	1.
2. $m\angle 1 = m\angle 4$	2.
3.	3. Definition of a Linear Pair
4. $\angle 1$ and $\angle 2$ are supplementary $\angle 3$ and $\angle 4$ are supplementary	4.
5.	5. Definition of supplementary angles
6. $m\angle 1 + m\angle 2 = m\angle 3 + m\angle 4$	6.
7. $m\angle 1 + m\angle 2 = m\angle 3 + m\angle 1$	7.
8. $m\angle 2 = m\angle 3$	8.
9. $\angle 2 \cong \angle 3$	9.

8. Given: $\angle C$ and $\angle F$ are right angles

Prove: $m\angle C + m\angle F = 180^\circ$

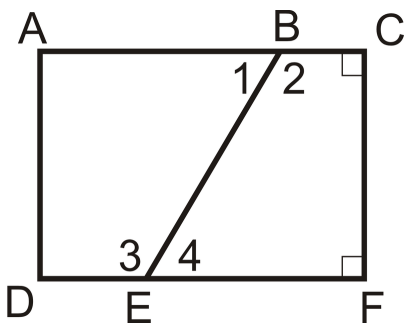

TABLE 2.15:

<i>Statement</i>	<i>Reason</i>
1.	1.
2. $m\angle C = 90^\circ, m\angle F = 90^\circ$	2.
3. $90^\circ + 90^\circ = 180^\circ$	3.
4. $m\angle C + m\angle F = 180^\circ$	4.

9. Given: $l \perp m$

Prove: $\angle 1 \cong \angle 2$

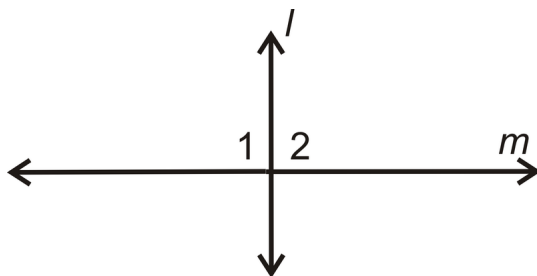

TABLE 2.16:

<i>Statement</i>	<i>Reason</i>
1. $l \perp m$	1.
2. $\angle 1$ and $\angle 2$ are right angles	2.
3.	3.

10. Given: $m\angle 1 = 90^\circ$

Prove: $m\angle 2 = 90^\circ$

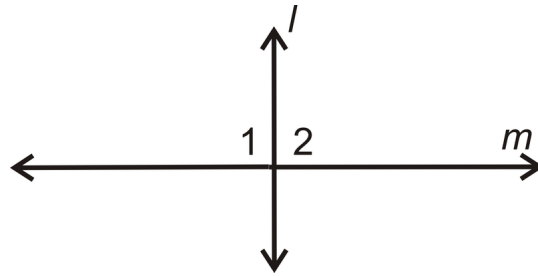

TABLE 2.17:

<i>Statement</i>	<i>Reason</i>
1.	1.
2. $\angle 1$ and $\angle 2$ are a linear pair	2.
3.	3. Linear Pair Postulate
4.	4. Definition of supplementary angles
5.	5. Substitution
6. $m\angle 2 = 90^\circ$	6.

11. Given: $l \perp m$

Prove: $\angle 1$ and $\angle 2$ are complements

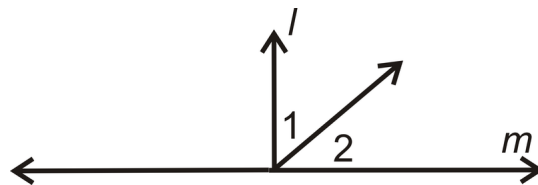

TABLE 2.18:

<i>Statement</i>	<i>Reason</i>
1.	1.
2.	2. \perp lines create right angles
3. $m\angle 1 + m\angle 2 = 90^\circ$	3.
4. $\angle 1$ and $\angle 2$ are complementary	4.

12. Given: $l \perp m$ and $\angle 2 \cong \angle 6$

Prove: $\angle 6 \cong \angle 5$

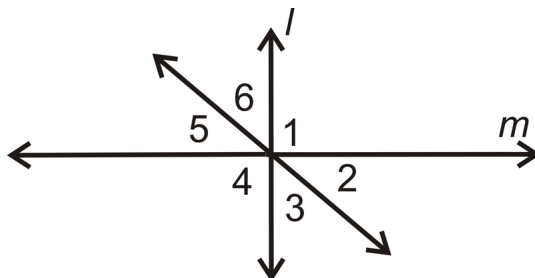

TABLE 2.19:

<i>Statement</i>	<i>Reason</i>
1.	1.
2. $m\angle 2 = m\angle 6$	2.
3. $\angle 5 \cong \angle 2$	3.
4. $m\angle 5 = m\angle 2$	4.
5. $m\angle 5 = m\angle 6$	5.

Summary

This chapter introduces the two types of reasoning, inductive and deductive. From this foundation, rewriting statements in if-then form is discussed and then the associated forms of converse, inverse, and contrapositive are presented. Biconditional statements are explored. How to offer a conjecture and how to provide a counterexample offer beginning steps to the necessary skills needed to complete two-column proofs. The properties of equality and congruence are reviewed and practice for completing two-column proofs is provided.

Parallel and Perpendicular Lines

Chapter Outline

- 3.1 PARALLEL AND SKEW LINES
 - 3.2 PERPENDICULAR LINES
 - 3.3 CORRESPONDING ANGLES
 - 3.4 ALTERNATE INTERIOR ANGLES
 - 3.5 ALTERNATE EXTERIOR ANGLES
 - 3.6 SAME SIDE INTERIOR ANGLES
 - 3.7 SLOPE IN THE COORDINATE PLANE
 - 3.8 PARALLEL LINES IN THE COORDINATE PLANE
 - 3.9 PERPENDICULAR LINES IN THE COORDINATE PLANE
 - 3.10 DISTANCE FORMULA IN THE COORDINATE PLANE
 - 3.11 DISTANCE BETWEEN PARALLEL LINES
-

Introduction

In this chapter, you will explore the different relationships formed by parallel and perpendicular lines and planes. Different angle relationships will also be explored and what happens when lines are parallel. You will start to prove lines parallel or perpendicular using a fill-in-the-blank 2-column proof. There is also an algebra review of the equations of lines, slopes, and how that relates to parallel and perpendicular lines in geometry.

3.1 Parallel and Skew Lines

Here you'll learn the difference between parallel and skew lines. You'll also learn basic properties of parallel lines and the definition of a transversal.

What if you were given a pair of lines that never intersect and were asked to describe them? What terminology would you use? After completing this Concept, you will be able to define the terms parallel line, skew line, and transversal. You'll also be able to apply the properties associated with parallel lines.

Watch This



MEDIA

Click image to the left for more content.

CK-12 Parallel and Skew Lines

Watch the portions of this video dealing with parallel lines.

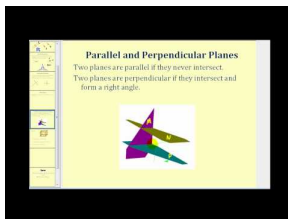

MEDIA

Click image to the left for more content.

James Sousa:Parallel Lines

Then watch this video.

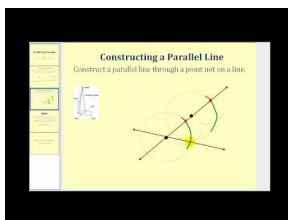

MEDIA

Click image to the left for more content.

James Sousa:Parallel Line Postulate

Guidance

Parallel lines are two or more lines that lie in the same plane and never intersect. To show that lines are parallel, arrows are used.

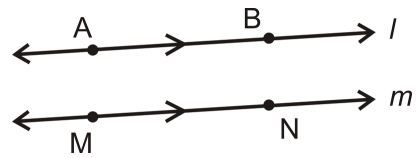

TABLE 3.1:

Label It
 $\overleftrightarrow{AB} \parallel \overleftrightarrow{MN}$
 $l \parallel m$

Say It
 Line AB is parallel to line MN
 Line l is parallel to line m .

In the definition of parallel the word “line” is used. However, line segments, rays and planes can also be parallel. The image below shows two parallel planes, with a third blue plane that is perpendicular to both of them.



Skew lines are lines that are in different planes and never intersect. They are different from parallel lines because parallel lines lie in the SAME plane. In the cube below, \overline{AB} and \overline{FH} are skew and \overline{AC} and \overline{EF} are skew.

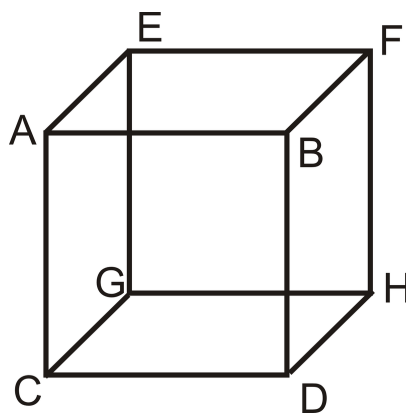

Basic Facts About Parallel Lines

Property: If lines $l \parallel m$ and $m \parallel n$, then $l \parallel n$.

If

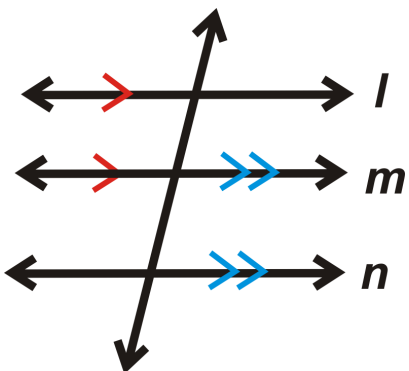

then

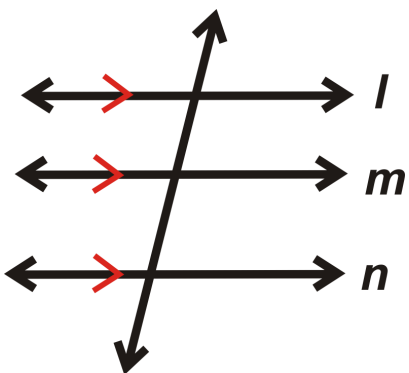

Postulate: For any line and a point *not* on the line, there is one line parallel to this line through the point. There are infinitely many lines that go through *A*, but only *one* that is parallel to *l*.

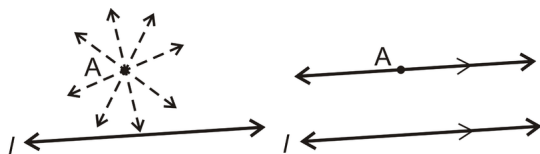

Transversals

A **transversal** is a line that intersects two other lines. The area *between* *l* and *m* is the *interior*. The area *outside* *l* and *m* is the *exterior*.

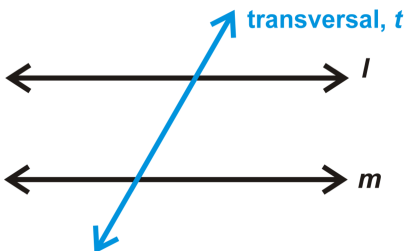

Example A

True or false: some pairs of skew lines are also parallel.

This is false, by definition skew lines are in **different** planes and parallel lines are in the **same** plane. Two lines could be skew or parallel (or neither), but never both.

Example B

Using the cube below, list a pair of parallel lines.

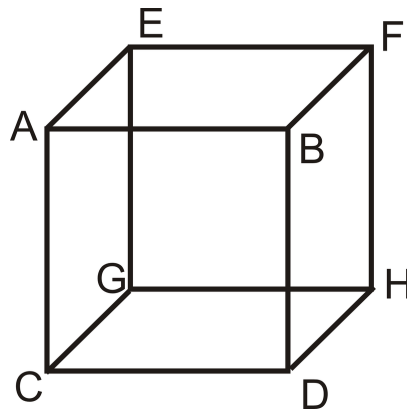

One possible answer is lines \overline{AB} and \overline{EF} .

Example C

Using the cube below, list a pair of skew lines.

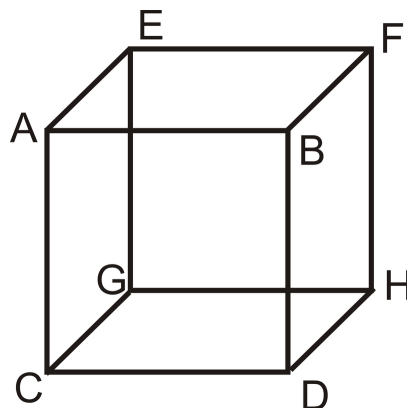

One possible answer is \overline{BD} and \overline{CG} .



MEDIA

Click image to the left for more content.

[CK-12 Parallel and Skew Lines](#)

Guided Practice

Use the figure below to answer the questions. The two pentagons are parallel and all of the rectangular sides are perpendicular to both of them.

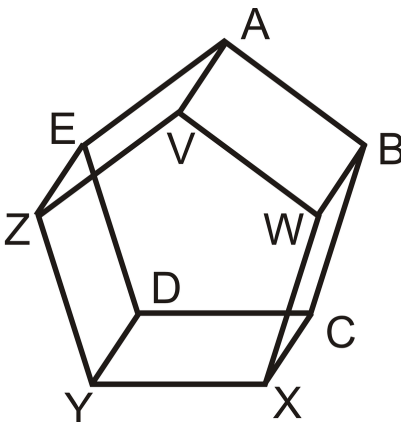

1. Find two pairs of skew lines.
2. List a pair of parallel lines.
3. For \overline{XY} , how many parallel lines would pass through point D ? Name this/these line(s).

Answers:

1. \overline{ZV} and \overline{WB} . \overline{YD} and \overline{VW}
2. \overline{ZV} and \overline{EA} .
3. One line, \overline{CD}

Practice

1. Which of the following is the best example of parallel lines?
 - a. Railroad Tracks
 - b. Lamp Post and a Sidewalk
 - c. Longitude on a Globe
 - d. Stonehenge (the stone structure in Scotland)
2. Which of the following is the best example of skew lines?
 - a. Roof of a Home
 - b. Northbound Freeway and an Eastbound Overpass
 - c. Longitude on a Globe
 - d. The Golden Gate Bridge

Use the picture below for questions 3-5.

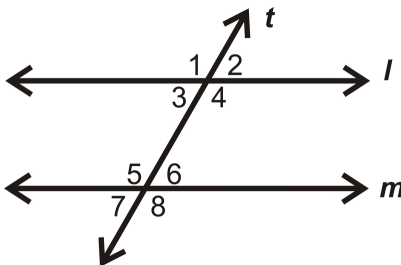

3. If $m\angle 2 = 55^\circ$, what other angles do you know?
4. If $m\angle 5 = 123^\circ$, what other angles do you know?

5. Is $l \parallel m$? Why or why not?

For 6-10, determine whether the statement is true or false.

6. If $p \parallel q$ and $q \parallel r$, then $p \parallel r$.
7. Skew lines are never in the same plane.
8. Skew lines can be perpendicular.
9. Planes can be parallel.
10. Parallel lines are never in the same plane.

3.2 Perpendicular Lines

Here you'll learn what perpendicular lines are and how to apply some basic properties and theorems about such lines.

What if you were given a pair of lines that intersect each other at a 90° angle? What terminology would you use to describe such lines? After completing this Concept, you will be able to define perpendicular lines. You'll also be able to apply the properties associated with such lines to solve for unknown angles.

Watch This



MEDIA

Click image to the left for more content.

CK-12 Perpendicular Lines

Watch the portions of this video dealing with perpendicular lines.

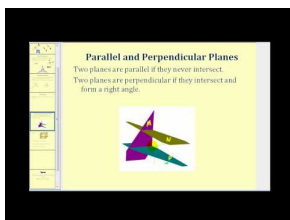

MEDIA

Click image to the left for more content.

James Sousa:Perpendicular Lines

Then watch this video.

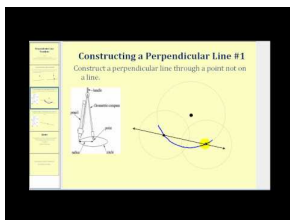

MEDIA

Click image to the left for more content.

James Sousa:Perpendicular Line Postulate

Guidance

Two lines are **perpendicular** when they intersect to form a 90° angle. Below, $l \perp \overline{AB}$.

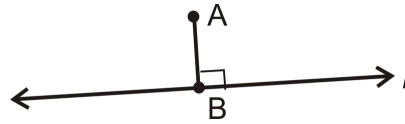

In the definition of perpendicular the word “line” is used. However, line segments, rays and planes can also be perpendicular. The image below shows two parallel planes, with a third blue plane that is perpendicular to both of them.



Basic Facts about Perpendicular Lines

Theorem #1: If $l \parallel m$ and $n \perp l$, then $n \perp m$.

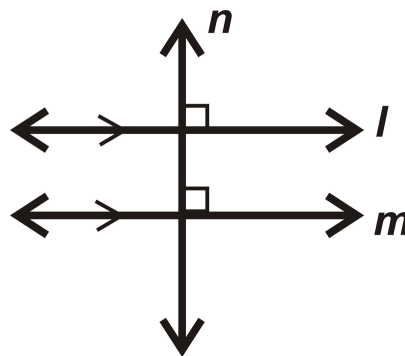

Theorem #2: If $l \perp n$ and $n \perp m$, then $l \parallel m$.

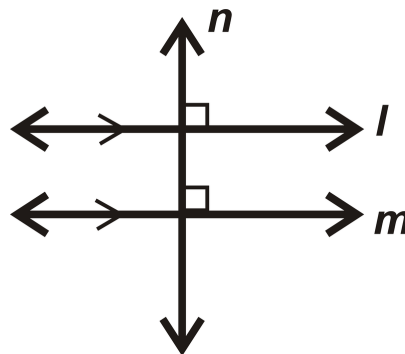

Postulate: For any line and a point **not** on the line, there is one line perpendicular to this line passing through the point. There are infinitely many lines that pass through A, but only **one** that is perpendicular to l.

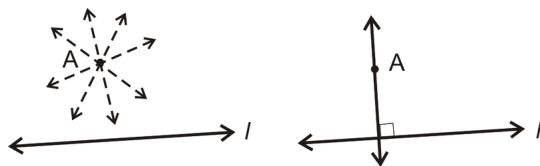
**Example A**

Which of the following is the best example of perpendicular lines?

1. Latitude on a Globe
2. Opposite Sides of a Picture Frame
3. Fence Posts
4. Adjacent Sides of a Picture Frame

The best example would be adjacent sides of a picture frame. Remember that adjacent means next to and sharing a vertex. The adjacent sides of a picture frame meet at a 90° angle and so these sides are perpendicular.

Example B

Is $\overleftrightarrow{SO} \perp \overleftrightarrow{GD}$?

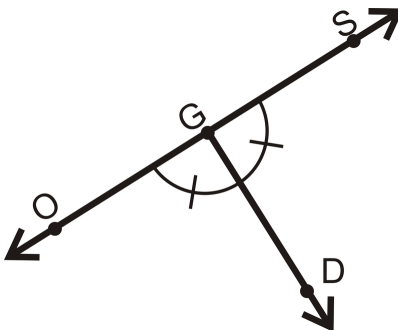

$\angle OGD \cong \angle SGD$ and the angles form a linear pair. This means both angles are 90° , so the lines are perpendicular.

Example C

Write a 2-column proof to prove Theorem #1. *Note: You need to understand corresponding angles in order to understand this proof. If you have not yet learned corresponding angles, be sure to check out that concept first, or skip this example for now.*

Given: $l \parallel m, l \perp n$

Prove: $n \perp m$

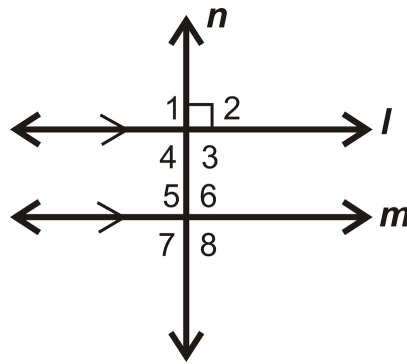

TABLE 3.2:

Statement

1. $l \parallel m, l \perp n$
2. $\angle 1, \angle 2, \angle 3,$ and $\angle 4$ are right angles
3. $m\angle 1 = 90^\circ$
4. $m\angle 1 = m\angle 5$
5. $m\angle 5 = 90^\circ$
6. $m\angle 6 = m\angle 7 = 90^\circ$
7. $m\angle 8 = 90^\circ$
8. $\angle 5, \angle 6, \angle 7,$ and $\angle 8$ are right angles
9. $n \perp m$

Reason

1. Given
2. Definition of perpendicular lines
3. Definition of a right angle
4. Corresponding Angles Postulate
5. Transitive *PoE*
6. Congruent Linear Pairs
7. Vertical Angles Theorem
8. Definition of right angle
9. Definition of perpendicular lines

**MEDIA**

Click image to the left for more content.

CK-12 Perpendicular Lines

Guided Practice

1. Find $m\angle CTA$.

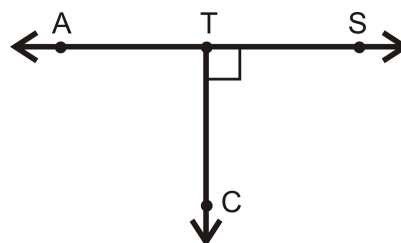

2. Determine the measure of $\angle 1$.

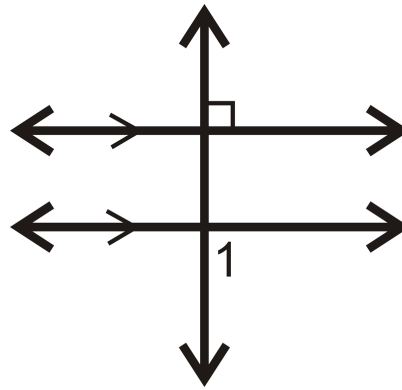

3. Find $m\angle 1$.

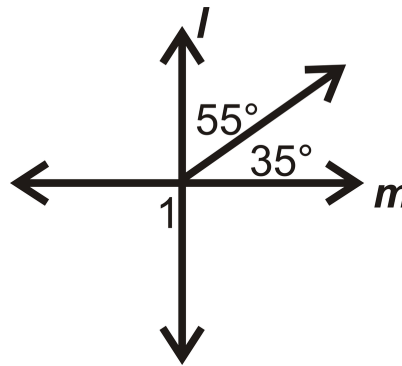

Answers:

1. These two angles form a linear pair and $\angle STC$ is a right angle.

$$m\angle STC = 90^\circ$$

$$m\angle CTA \text{ is } 180^\circ - 90^\circ = 90^\circ$$

2. We know that both parallel lines are perpendicular to the transversal.

$$m\angle 1 = 90^\circ.$$

3. The two adjacent angles add up to 90° , so $l \perp m$.

$$m\angle 1 = 90^\circ$$

because it is a vertical angle to the pair of adjacent angles and vertical angles are congruent.

Practice

Use the figure below to answer questions 1-2. The two pentagons are parallel and all of the rectangular sides are perpendicular to both of them.

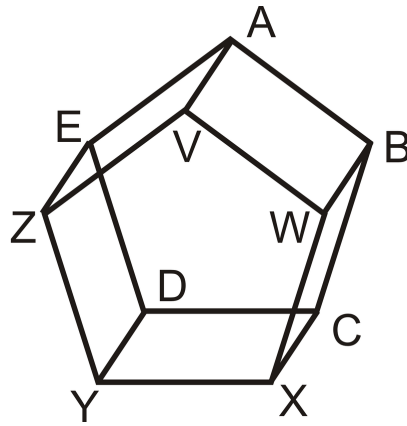

1. List a pair of perpendicular lines.
2. For \overline{AB} , how many perpendicular lines would pass through point V? Name this/these line(s).

Use the picture below for questions 3.

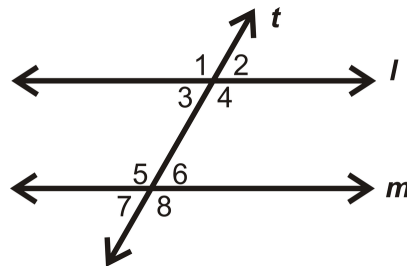

3. If $t \perp l$, is $t \perp m$? Why or why not?

Find the measure of $\angle 1$ for each problem below.

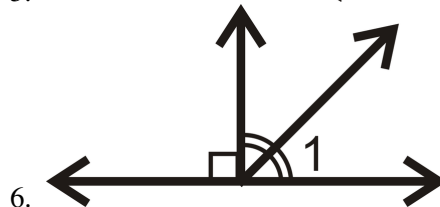
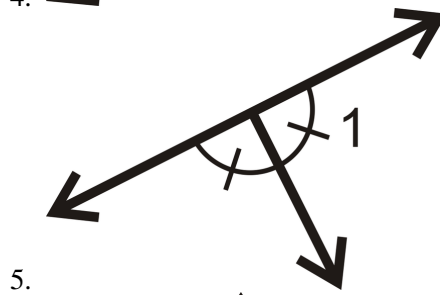
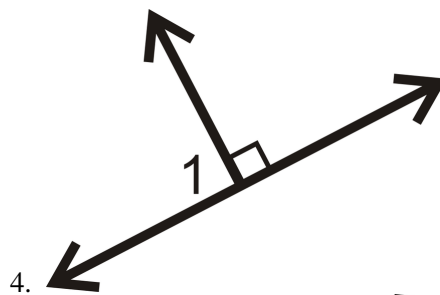

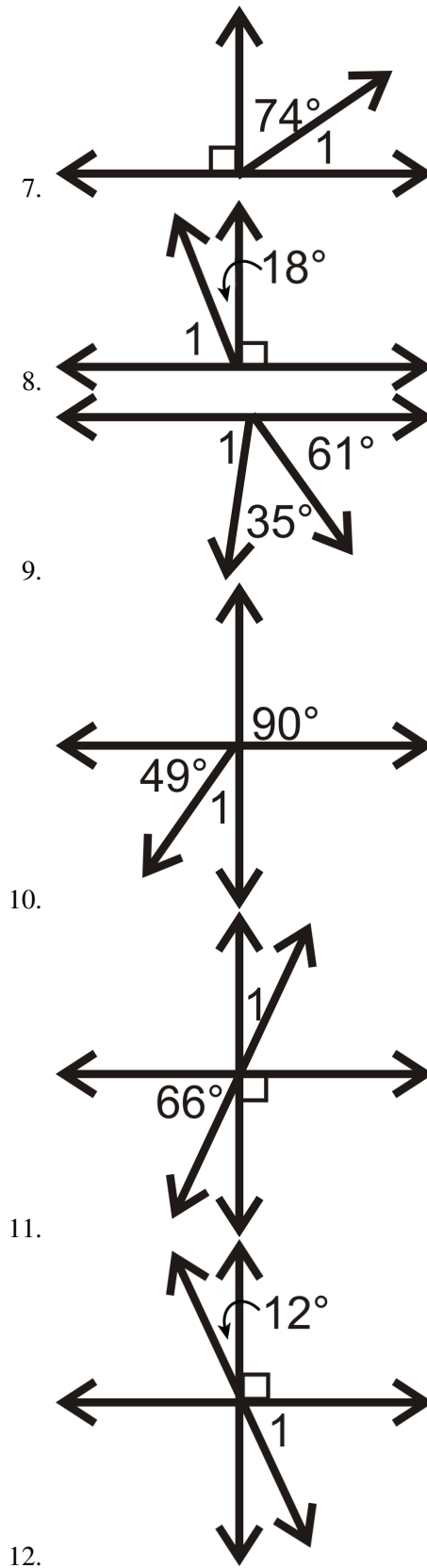

In questions 13-16, determine if $l \perp m$.

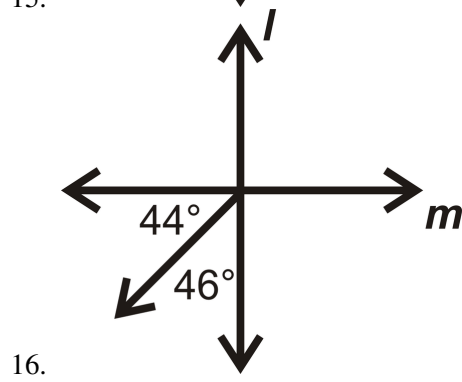
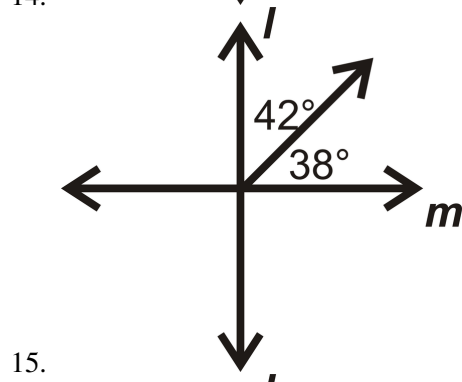
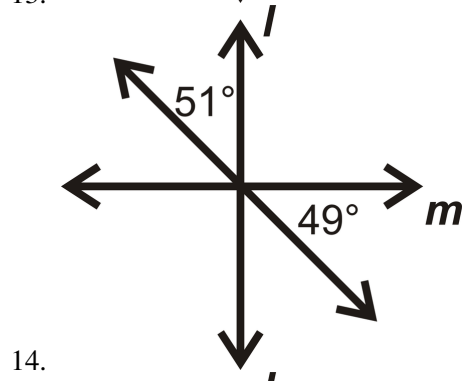
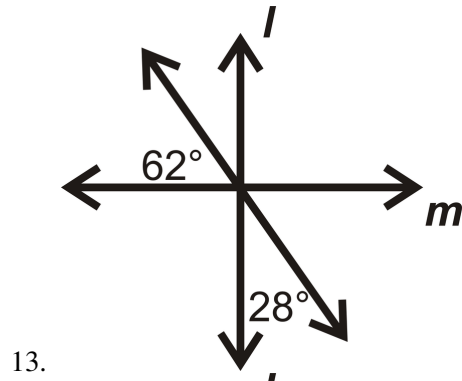

Fill in the blanks in the proof below.

17. Given: $l \perp m, l \perp n$ Prove: $m \parallel n$

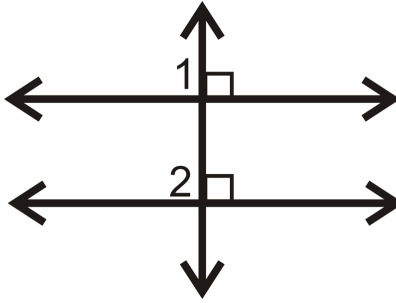

TABLE 3.3:

<i>Statement</i>	<i>Reason</i>
1.	1.
2. $\angle 1$ and $\angle 2$ are right angles	2.
3.	3. Definition of right angles
4.	4. Transitive <i>PoE</i>
5. $m \parallel n$	5.

3.3 Corresponding Angles

Here you'll learn what corresponding angles are and what relationship they have with parallel lines.

What if you were presented with two angles that are in the same place with respect to the transversal but on different lines? How would you describe these angles and what could you conclude about their measures? After completing this Concept, you'll be able to answer these questions and use corresponding angle postulates.

Watch This



MEDIA

Click image to the left for more content.

CK-12 Corresponding Angles

Watch the portions of this video dealing with corresponding angles.

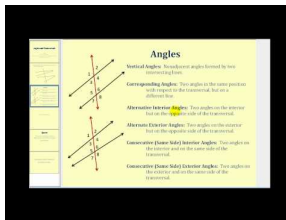

MEDIA

Click image to the left for more content.

James Sousa:Angles and Transversals

Then watch this video beginning at the 4:50 mark.

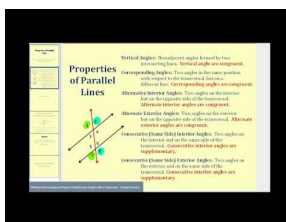

MEDIA

Click image to the left for more content.

James Sousa:Corresponding Angles Postulate

Finally, watch this video.

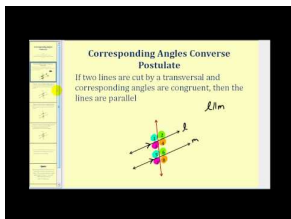

MEDIA

Click image to the left for more content.

James Sousa:Corresponding Angles Converse

Guidance

Corresponding angles are two angles that are in the "same place" with respect to the transversal but on different lines. Imagine sliding the four angles formed with line l down to line m . The angles which match up are corresponding.

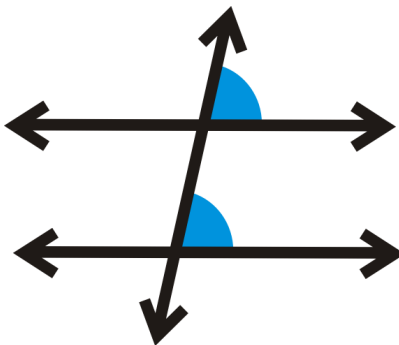

Corresponding Angles Postulate: If two parallel lines are cut by a transversal, then the corresponding angles are congruent.

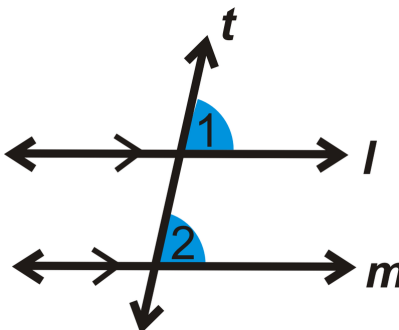

If $l \parallel m$, then $\angle 1 \cong \angle 2$.

Converse of Corresponding Angles Postulate: If corresponding angles are congruent when two lines are cut by a transversal, then the lines are parallel.

If

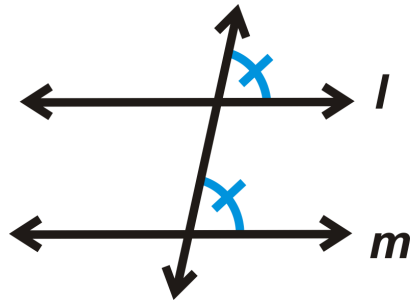

then $l \parallel m$.

Example A

If $a \parallel b$, which pairs of angles are congruent by the Corresponding Angles Postulate?

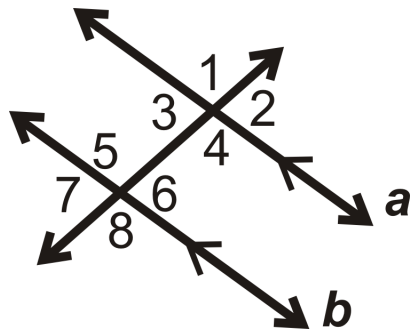

There are 4 pairs of congruent corresponding angles:

$\angle 1 \cong \angle 5$, $\angle 2 \cong \angle 6$, $\angle 3 \cong \angle 7$, and $\angle 4 \cong \angle 8$.

Example B

If $m\angle 2 = 76^\circ$, what is $m\angle 6$?

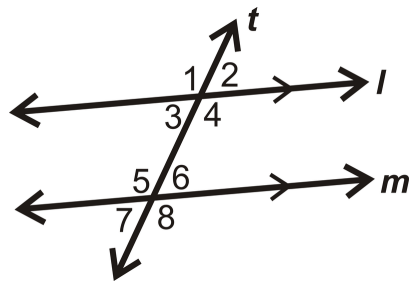

$\angle 2$ and $\angle 6$ are corresponding angles and $l \parallel m$ from the arrows in the figure. $\angle 2 \cong \angle 6$ by the Corresponding Angles Postulate, which means that $m\angle 6 = 76^\circ$.

Example C

If $m\angle 8 = 110^\circ$ and $m\angle 4 = 110^\circ$, then what do we know about lines l and m ?

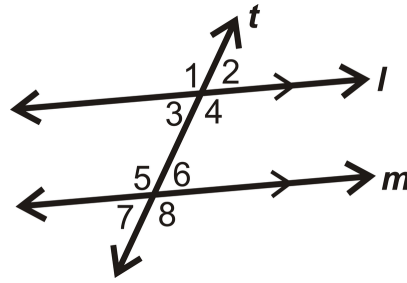

$\angle 8$ and $\angle 4$ are corresponding angles. Since $m\angle 8 = m\angle 4$, we can conclude that $l \parallel m$.



MEDIA
Click image to the left for more content.

CK-12 Corresponding Angles

Guided Practice

- Using the measures of $\angle 2$ and $\angle 6$ from Example B, find all the other angle measures.
- Is $l \parallel m$?

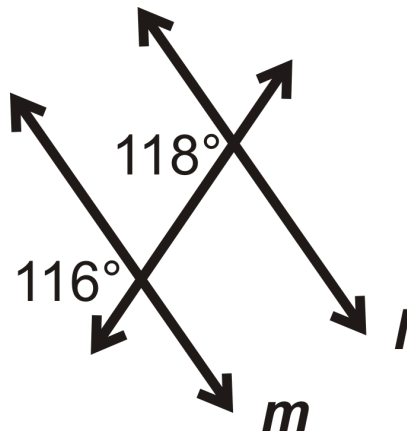

- Find the value of y :

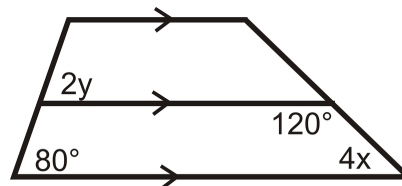

Answers:

- If $m\angle 2 = 76^\circ$, then $m\angle 1 = 180^\circ - 76^\circ = 104^\circ$ (linear pair). $\angle 3 \cong \angle 2$ (vertical angles), so $m\angle 3 = 76^\circ$. $m\angle 4 = 104^\circ$ (vertical angle with $\angle 1$).

By the Corresponding Angles Postulate, we know $\angle 1 \cong \angle 5$, $\angle 2 \cong \angle 6$, $\angle 3 \cong \angle 7$, and $\angle 4 \cong \angle 8$, so $m\angle 5 = 104^\circ$, $m\angle 6 = 76^\circ$, $m\angle 7 = 76^\circ$, and $m\angle 8 = 104^\circ$.

2. The two angles are corresponding and must be equal to say that $l \parallel m$. $116^\circ \neq 118^\circ$, so l is not parallel to m .

3. The horizontal lines are marked parallel and the angle marked $2y$ is corresponding to the angle marked 80 so these two angles are congruent. This means that $2y = 80$ and therefore $y = 40$.

Practice

- Determine if the angle pair $\angle 4$ and $\angle 2$ is congruent, supplementary or neither:

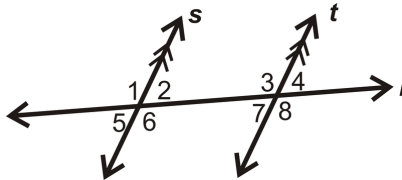

- Give two examples of corresponding angles in the diagram:

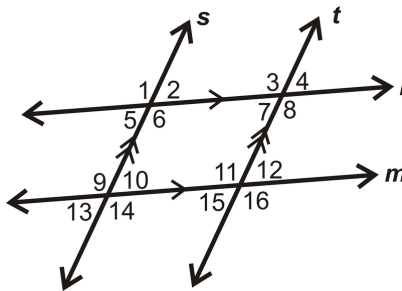

- Find the value of x :

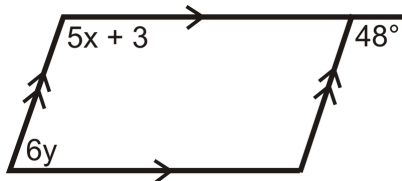

- Are the lines parallel? Why or why not?

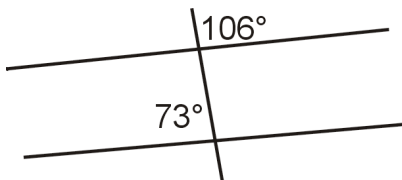

- Are the lines parallel? Justify your answer.

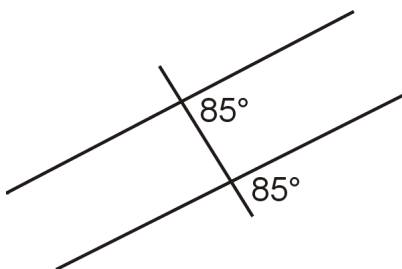

For 6-10, what does the value of x have to be to make the lines parallel?

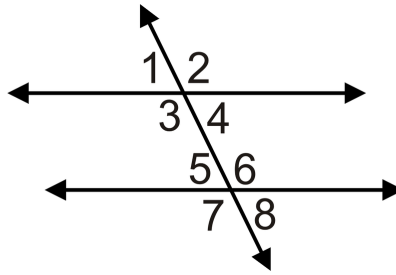

6. If $m\angle 1 = (6x - 5)^\circ$ and $m\angle 5 = (5x + 7)^\circ$.
7. If $m\angle 2 = (3x - 4)^\circ$ and $m\angle 6 = (4x - 10)^\circ$.
8. If $m\angle 3 = (7x - 5)^\circ$ and $m\angle 7 = (5x + 11)^\circ$.
9. If $m\angle 4 = (5x - 5)^\circ$ and $m\angle 8 = (3x + 15)^\circ$.
10. If $m\angle 2 = (2x + 4)^\circ$ and $m\angle 6 = (5x - 2)^\circ$.

3.4 Alternate Interior Angles

Here you'll learn what alternate interior angles are and what relationship they have with parallel lines.

What if you were presented with two angles that are on the interior of two parallel lines cut by a transversal but on opposite sides of the transversal? How would you describe these angles and what could you conclude about their measures? After completing this Concept, you'll be able to answer these questions and apply alternate interior angle theorems to find the measure of unknown angles.

Watch This



MEDIA

Click image to the left for more content.

CK-12 Alternate Interior Angles

Watch the portions of this video dealing with alternate interior angles.

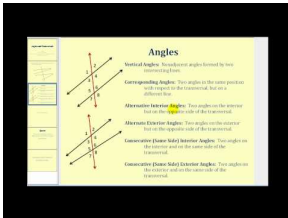

MEDIA

Click image to the left for more content.

James Sousa: Angles and Transversals

Then watch this video.

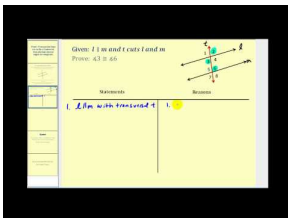

MEDIA

Click image to the left for more content.

James Sousa: Proof that Alternate Interior Angles Are Congruent

Finally, watch this video.

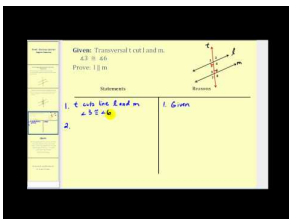

MEDIA

Click image to the left for more content.

James Sousa:Proof of Alternate Interior Angles Converse

Guidance

Alternate interior angles are two angles that are on the interior of l and m , but on opposite sides of the transversal.

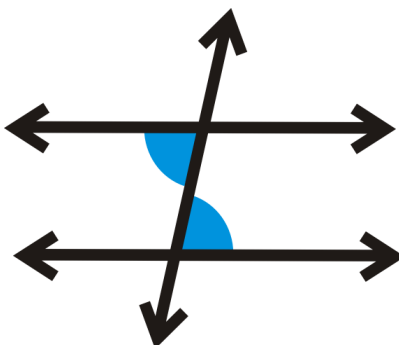

Alternate Interior Angles Theorem: If two parallel lines are cut by a transversal, then the alternate interior angles are congruent.

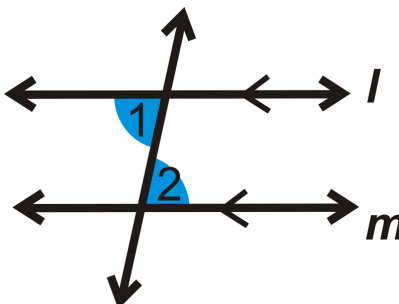

If $l \parallel m$, then $\angle 1 \cong \angle 2$

Converse of Alternate Interior Angles Theorem: If two lines are cut by a transversal and the alternate interior angles are congruent, then the lines are parallel.

If

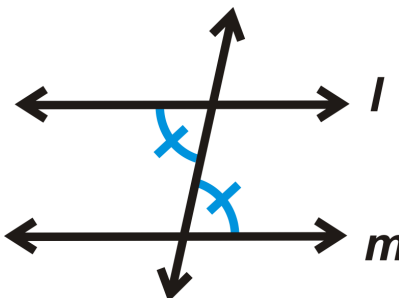

then $l \parallel m$.

Example A

Find the value of x .

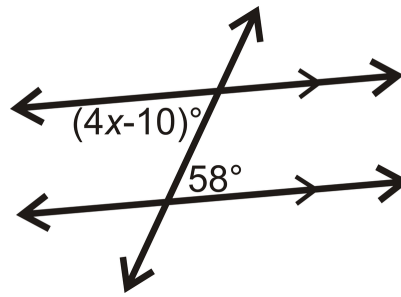

The two given angles are alternate interior angles and equal.

$$\begin{aligned}(4x - 10)^\circ &= 58^\circ \\ 4x &= 68 \\ x &= 17\end{aligned}$$

Example B

True or false: alternate interior angles are always congruent.

This statement is false, but is a common misconception. Remember that alternate interior angles are only congruent when the lines are parallel.

Example C

What does x have to be to make $a \parallel b$?

The angles are alternate interior angles, and must be equal for $a \parallel b$. Set the expressions equal to each other and solve.

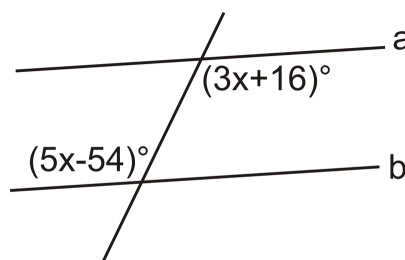

$$\begin{aligned}3x + 16^\circ &= 5x - 54^\circ \\ 70 &= 2x \\ 35 &= x\end{aligned}$$

To make $a \parallel b$, $x = 35$.



MEDIA
Click image to the left for more content.

CK-12 Alternate Interior Angles

Guided Practice

Use the given information to determine which lines are parallel. If there are none, write none. Consider each question individually.

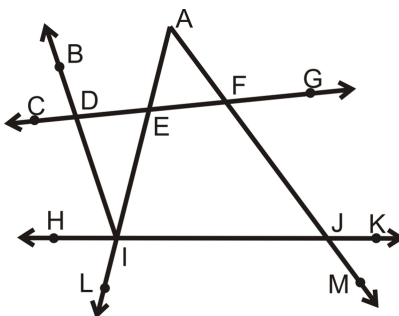

1. $\angle EAF \cong \angle FJI$
2. $\angle EFJ \cong \angle FJK$
3. $\angle DIE \cong \angle EAF$

Answers:

1. None
2. $\vec{CG} \parallel \vec{HK}$
3. $\vec{BI} \parallel \vec{AM}$

Practice

1. Is the angle pair $\angle 6$ and $\angle 3$ congruent, supplementary or neither?

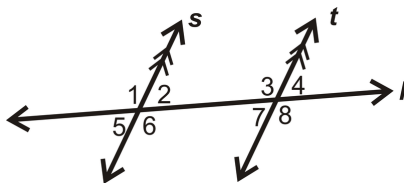

2. Give two examples of alternate interior angles in the diagram:

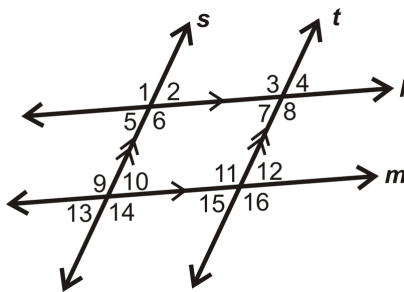

For 3-4, find the values of x .

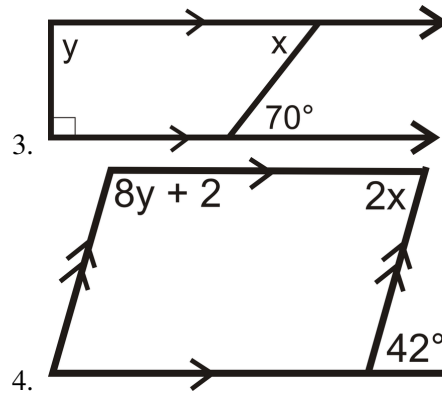

For question 5, use the picture below. Find the value of x .

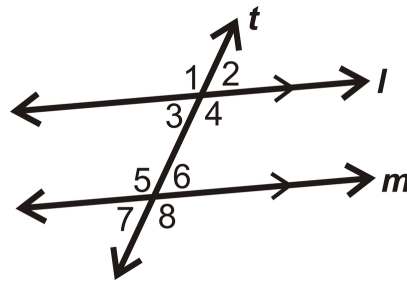

5. $m\angle 4 = (5x - 33)^\circ$, $m\angle 5 = (2x + 60)^\circ$

6. Are lines l and m parallel? If yes, how do you know?

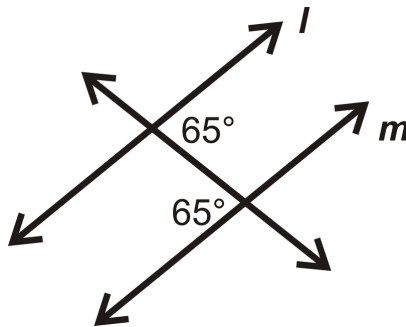

For 7-10, what does the value of x have to be to make the lines parallel?

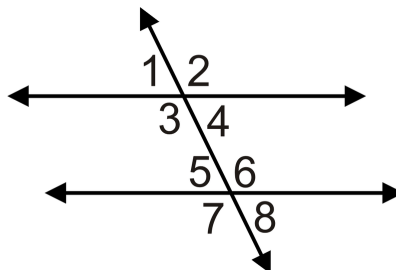

7. $m\angle 4 = (3x - 7)^\circ$ and $m\angle 5 = (5x - 21)^\circ$

8. $m\angle 3 = (2x - 1)^\circ$ and $m\angle 6 = (4x - 11)^\circ$
9. $m\angle 3 = (5x - 2)^\circ$ and $m\angle 6 = (3x)^\circ$
10. $m\angle 4 = (x - 7)^\circ$ and $m\angle 5 = (5x - 31)^\circ$

3.5 Alternate Exterior Angles

Here you'll learn what alternate exterior angles are and what relationship they have with parallel lines.

What if you were presented with two angles that are on the exterior of two parallel lines cut by a transversal but on opposite sides of the transversal? How would you describe these angles and what could you conclude about their measures? After completing this Concept, you'll be able to answer these questions and apply alternate exterior angle theorems to find the measure of unknown angles.

Watch This



MEDIA

Click image to the left for more content.

CK-12 Alternate Exterior Angles

Watch the portions of this video dealing with alternate exterior angles.

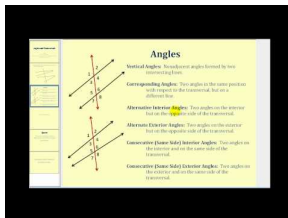

MEDIA

Click image to the left for more content.

James Sousa: Angles and Transversals

Then watch this video.

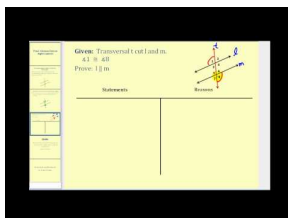

MEDIA

Click image to the left for more content.

James Sousa: Proof of Alternate Exterior Angles Converse

Guidance

Alternate exterior angles are two angles that are on the exterior of l and m , but on opposite sides of the transversal.

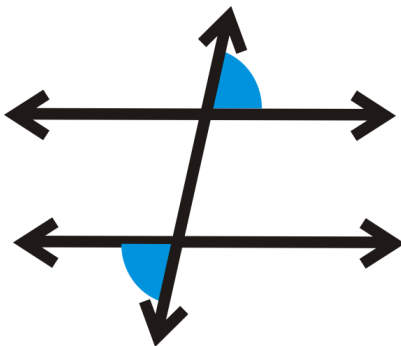

Alternate Exterior Angles Theorem: If two parallel lines are cut by a transversal, then the alternate exterior angles are congruent.

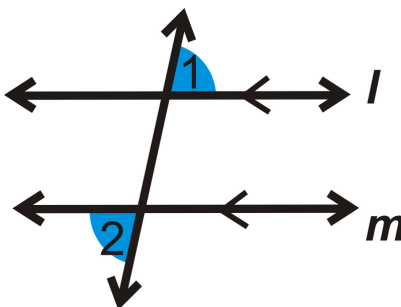

If $l \parallel m$, then $\angle 1 \cong \angle 2$.

Converse of the Alternate Exterior Angles Theorem: If two lines are cut by a transversal and the alternate exterior angles are congruent, then the lines are parallel.

If

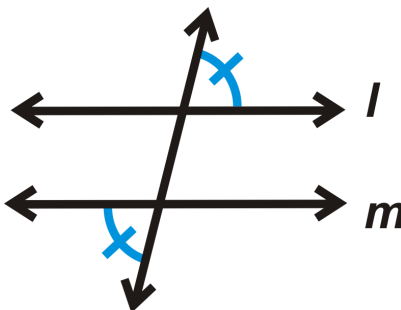

then $l \parallel m$.

Example A

Find the measure of each angle and the value of y .

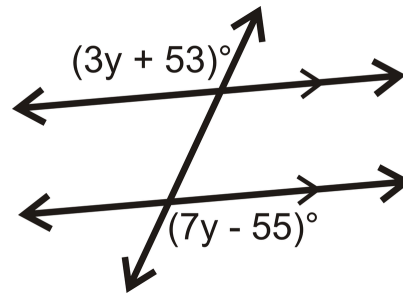

The angles are alternate exterior angles. Because the lines are parallel, the angles are equal.

$$\begin{aligned}(3y + 53)^\circ &= (7y - 55)^\circ \\ 108 &= 4y \\ 27 &= y\end{aligned}$$

If $y = 27$, then each angle is $[3(27) + 53]^\circ = 134^\circ$.

Example B

The map below shows three roads in Julio's town.

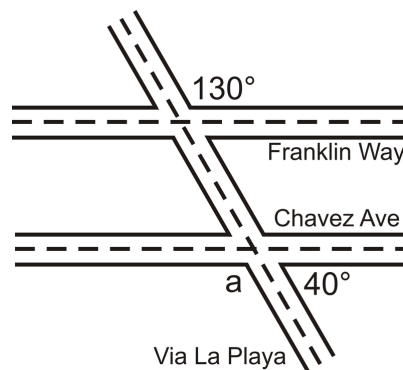

Julio used a surveying tool to measure two angles at the intersections in this picture he drew (NOT to scale). **Julio wants to know if Franklin Way is parallel to Chavez Avenue.**

The 130° angle and $\angle a$ are alternate exterior angles. If $m\angle a = 130^\circ$, then the lines are parallel.

$$\begin{aligned}\angle a + 40^\circ &= 180^\circ && \text{by the Linear Pair Postulate} \\ \angle a &= 140^\circ\end{aligned}$$

$140^\circ \neq 130^\circ$, so Franklin Way and Chavez Avenue are not parallel streets.

Example C

Which lines are parallel if $\angle AFG \cong \angle IJM$?

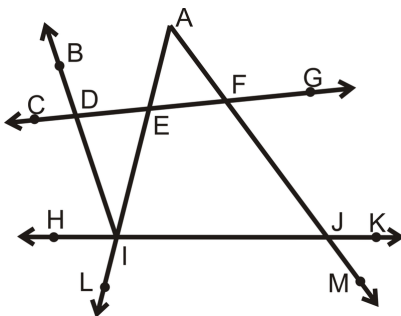

These two angles are alternate exterior angles so if they are congruent it means that $\overleftrightarrow{CG} \parallel \overleftrightarrow{HK}$.



MEDIA

Click image to the left for more content.

CK-12 Alternate Exterior Angles

Guided Practice

Give THREE examples of pairs of alternate exterior angles in the diagram below:

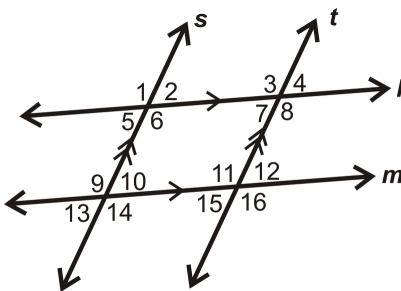

Answers:

There are many examples of alternate exterior angles in the diagram. Here are some possible answers:

1. $\angle 1$ and $\angle 14$
2. $\angle 2$ and $\angle 13$
3. $\angle 12$ and $\angle 13$

Practice

1. Find the value of x if $m\angle 1 = (4x + 35)^\circ$, $m\angle 8 = (7x - 40)^\circ$:

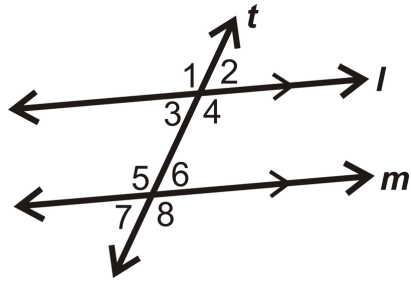

2. Are lines 1 and 2 parallel? Why or why not?

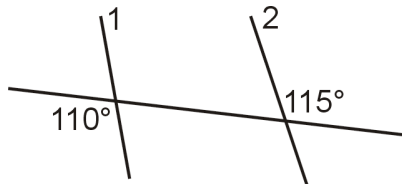

For 3-6, what does the value of x have to be to make the lines parallel?

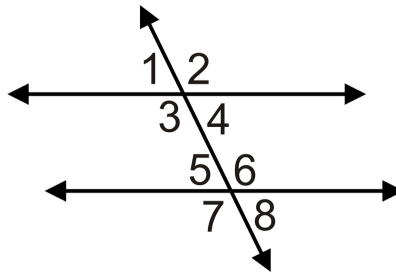

3. $m\angle 2 = (8x)^\circ$ and $m\angle 7 = (11x - 36)^\circ$
4. $m\angle 1 = (3x + 5)^\circ$ and $m\angle 8 = (4x - 3)^\circ$
5. $m\angle 2 = (6x - 4)^\circ$ and $m\angle 7 = (5x + 10)^\circ$
6. $m\angle 1 = (2x - 5)^\circ$ and $m\angle 8 = (x)^\circ$

For 7-10, determine whether the statement is true or false.

7. Alternate exterior angles are always congruent.
8. If alternate exterior angles are congruent then lines are parallel.
9. Alternate exterior angles are on the interior of two lines.
10. Alternate exterior angles are on opposite sides of the transversal.

3.6 Same Side Interior Angles

Here you'll learn what same side interior angles are and what relationship they have with parallel lines.

What if you were presented with two angles that are on the same side of the transversal and on the interior of the two lines? How would you describe these angles and what could you conclude about their measures? After completing this Concept, you'll be able to answer these questions and apply same side interior angle theorems to find the measure of unknown angles.

Watch This



MEDIA

Click image to the left for more content.

CK-12 Same Side Interior Angles

Watch the portions of this video dealing with same side interior angles.

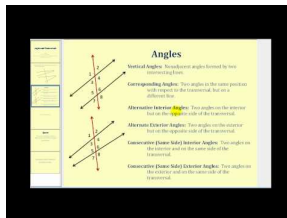

MEDIA

Click image to the left for more content.

James Sousa: Angles and Transversals

Then watch this video.

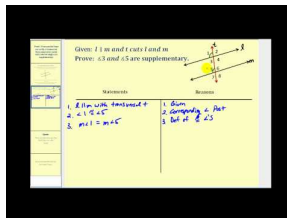

MEDIA

Click image to the left for more content.

James Sousa: Proof that Consecutive Interior Angles Are Supplementary

Finally, watch this video.

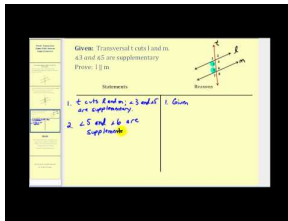

MEDIA

Click image to the left for more content.

James Sousa:Proof of Consecutive Interior Angles Converse

Guidance

Same side interior angles are two angles that are on the same side of the transversal and on the interior of the two lines.

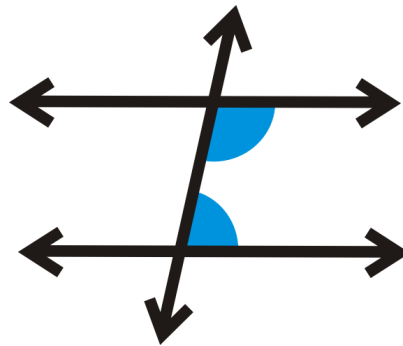

Same Side Interior Angles Theorem: If two parallel lines are cut by a transversal, then the same side interior angles are supplementary.

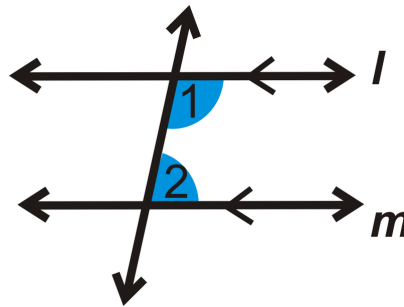

If $l \parallel m$, then $m\angle 1 + m\angle 2 = 180^\circ$.

Converse of the Same Side Interior Angles Theorem: If two lines are cut by a transversal and the same side interior angles are supplementary, then the lines are parallel.

If

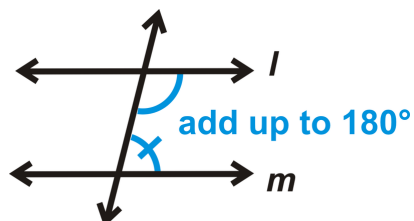

then $l \parallel m$.

Example A

Find z .

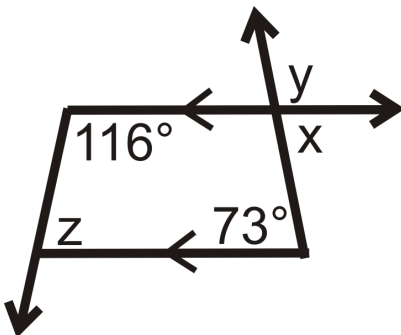

$z + 116^\circ = 180^\circ$ so $z = 64^\circ$ by Same Side Interior Angles Theorem.

Example B

Is $l \parallel m$? How do you know?

These angles are Same Side Interior Angles. So, if they add up to 180° , then $l \parallel m$.

$130^\circ + 67^\circ = 197^\circ$, therefore the lines are not parallel.

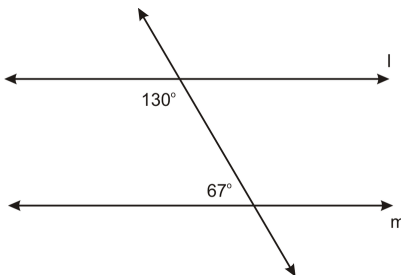

Example C

Give two examples of same side interior angles in the diagram below:

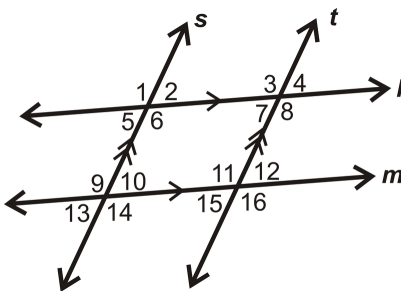

There are MANY examples of same side interior angles in the diagram. Two are $\angle 6$ and $\angle 10$, and $\angle 8$ and $\angle 12$.



MEDIA

 Click image to the left for more content.

CK-12 Same Side Interior Angles

Guided Practice

1. Find the value of x .

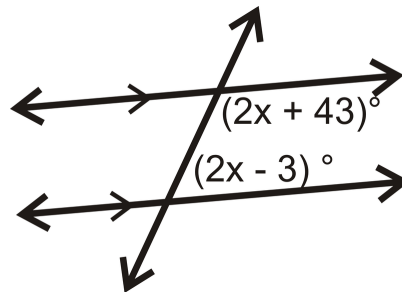

2. Find the value of y .

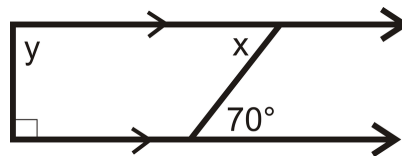

3. Find the value of x if $m\angle 3 = (3x + 12)^\circ$ and $m\angle 5 = (5x + 8)^\circ$.

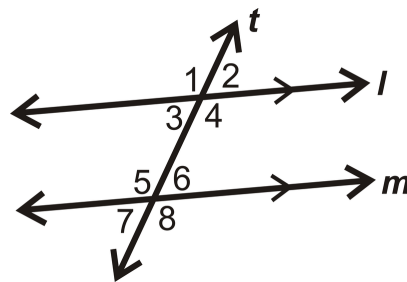

Answers:

1. The given angles are same side interior angles. Because the lines are parallel, the angles add up to 180° .

$$(2x + 43)^\circ + (2x - 3)^\circ = 180^\circ$$

$$(4x + 40)^\circ = 180^\circ$$

$$4x = 140$$

$$x = 35$$

- y is a same side interior angle with the marked right angle. This means that $90^\circ + y = 180$ so $y = 90$.
- These are same side interior angles so set up an equation and solve for x . Remember that same side interior angles add up to 180° .

$$\begin{aligned} (3x + 12)^\circ + (5x + 8)^\circ &= 180^\circ \\ (8x + 20)^\circ &= 180^\circ \\ 8x &= 160 \\ x &= 20 \end{aligned}$$

Practice

For questions 1-2, determine if each angle pair below is congruent, supplementary or neither.

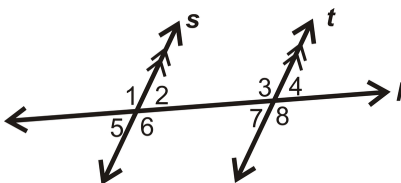

- $\angle 5$ and $\angle 8$
- $\angle 2$ and $\angle 3$
- Are the lines below parallel? Justify your answer.

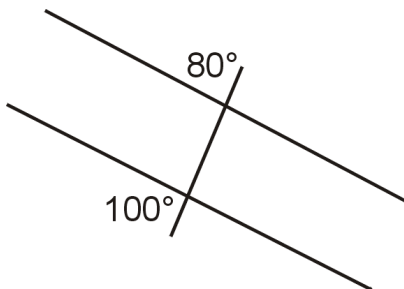

In 4-5, use the given information to determine which lines are parallel. If there are none, write none. Consider each question individually.

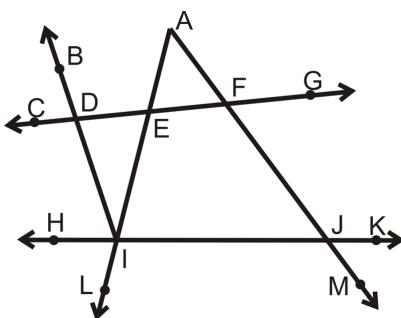

- $\angle AFD$ and $\angle BDF$ are supplementary
- $\angle DIJ$ and $\angle FJI$ are supplementary

For 6-8, what does the value of x have to be to make the lines parallel?

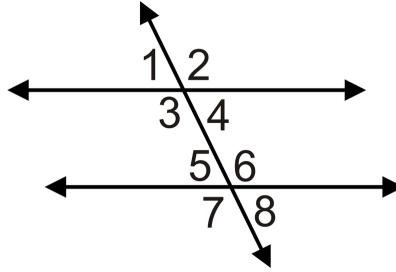

6. $m\angle 3 = (3x + 25)^\circ$ and $m\angle 5 = (4x - 55)^\circ$

7. $m\angle 4 = (2x + 15)^\circ$ and $m\angle 6 = (3x - 5)^\circ$

8. $m\angle 3 = (x + 17)^\circ$ and $m\angle 5 = (3x - 5)^\circ$

For 9-10, determine whether the statement is true or false.

9. Same side interior angles are on the same side of the transversal.
10. Same side interior angles are congruent when lines are parallel.

3.7 Slope in the Coordinate Plane

Here you'll learn how to find the slope of a line given two of its points and you'll review the different types of slope. What if you were given the coordinates of two points? How would you determine the steepness of the line they form? After completing this Concept, you'll be able to find the slope of a line through two points.

Watch This



MEDIA

Click image to the left for more content.

CK-12 Slope in the Coordinate Plane

Guidance

Recall from Algebra I that **slope** is the measure of the steepness of a line. Two points (x_1, y_1) and (x_2, y_2) have a slope of $m = \frac{(y_2 - y_1)}{(x_2 - x_1)}$. You might have also learned slope as $\frac{\text{rise}}{\text{run}}$. This is a great way to remember the formula. Also remember that if an equation is written in slope-intercept form, $y = mx + b$, then m is always the slope of the line.

Slopes can be positive, negative, zero, or undefined as shown in the pictures below:

Positive:

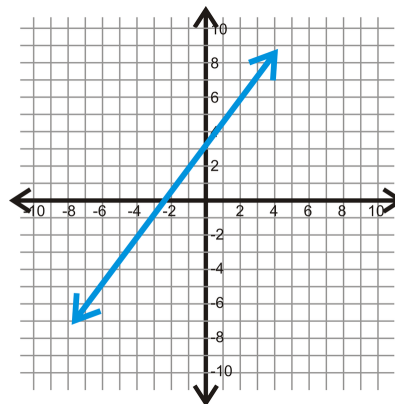

Negative:

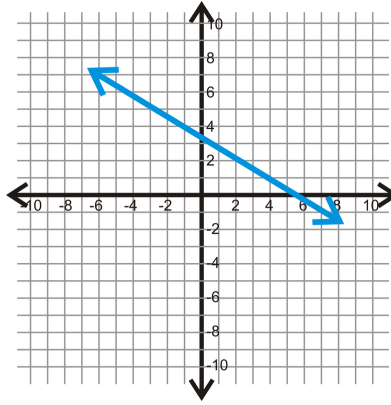

Zero:

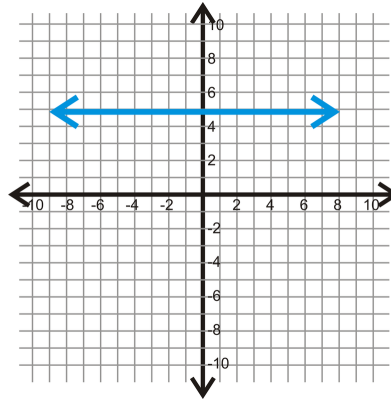

Undefined:

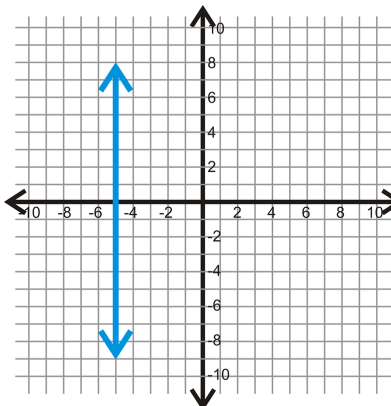

Example A

What is the slope of the line through (2, 2) and (4, 6)?

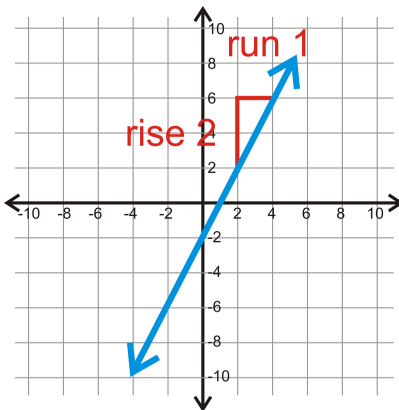

Use (2, 2) as (x_1, y_1) and (4, 6) as (x_2, y_2) .

$$m = \frac{6 - 2}{4 - 2} = \frac{4}{2} = 2$$

Example B

Find the slope between $(-8, 3)$ and $(2, -2)$.

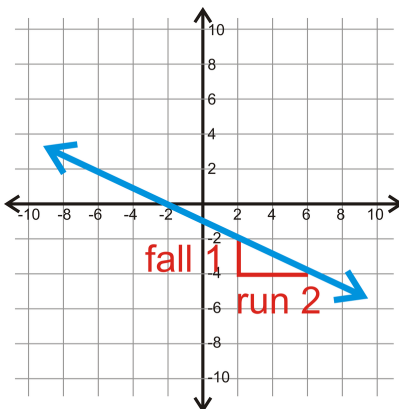

Use $(-8, 3)$ as (x_1, y_1) and $(2, -2)$ as (x_2, y_2) .

$$m = \frac{-2 - 3}{2 - (-8)} = \frac{-5}{10} = -\frac{1}{2}$$

Example C

The picture shown is the California Incline, a short road that connects Highway 1 with Santa Monica. The length of the road is 1532 feet and has an elevation of 177 feet. *You may assume that the base of this incline is zero feet.* **Can you find the slope of the California Incline?**



In order to find the slope, we need to first find the horizontal distance in the triangle shown. This triangle represents the incline and the elevation. To find the horizontal distance, we need to use the Pythagorean Theorem (a concept you will be introduced to formally in a future lesson), $a^2 + b^2 = c^2$, where c is the hypotenuse.

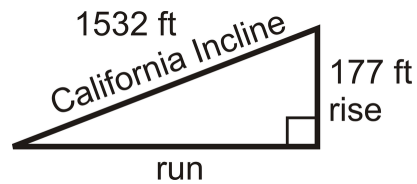

$$\begin{aligned} 177^2 + \text{run}^2 &= 1532^2 \\ 31,329 + \text{run}^2 &= 2,347,024 \\ \text{run}^2 &= 2,315,695 \\ \text{run} &\approx 1521.75 \end{aligned}$$

The slope is then $\frac{177}{1521.75}$, which is roughly $\frac{3}{25}$.



MEDIA

Click image to the left for more content.

CK-12 Slope in the Coordinate Plane

Guided Practice

- Find the slope between $(-5, -1)$ and $(3, -1)$.

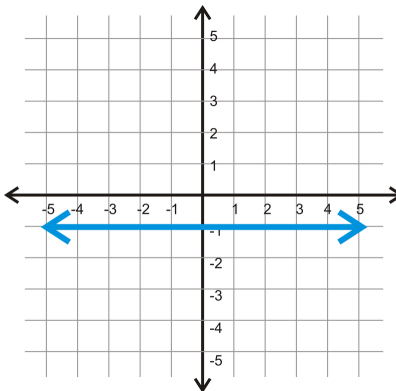

2. What is the slope of the line through (3, 2) and (3, 6)?

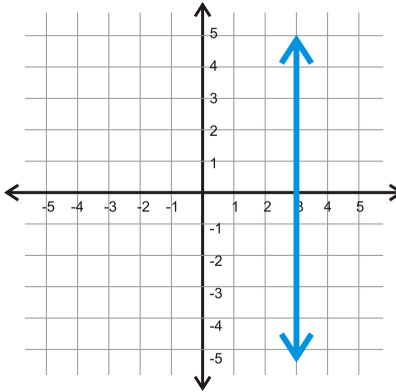

3. Find the slope between (-5, 2) and (3, 4).

Answers:

1. Use (-5, -1) as (x_1, y_1) and (3, -1) as (x_2, y_2) .

$$m = \frac{-1 - (-1)}{3 - (-5)} = \frac{0}{8} = 0$$

The slope of this line is 0, or a horizontal line. Horizontal lines always pass through the y -axis. The y -coordinate for both points is -1. So, the equation of this line is $y = -1$.

2. Use (3, 2) as (x_1, y_1) and (3, 6) as (x_2, y_2) .

$$m = \frac{6 - 2}{3 - 3} = \frac{4}{0} = \text{undefined}$$

The slope of this line is undefined, which means that it is a vertical line. Vertical lines always pass through the x -axis. The x -coordinate for both points is 3.

So, the equation of this line is $x = 3$.

3. Use (-5, 2) as (x_1, y_1) and (3, 4) as (x_2, y_2) .

$$m = \frac{4 - 2}{3 - (-5)} = \frac{2}{8} = \frac{1}{4}$$

Practice

Find the slope between the two given points.

- (4, -1) and (-2, -3)
- (-9, 5) and (-6, 2)
- (7, 2) and (-7, -2)
- (-6, 0) and (-1, -10)
- (1, -2) and (3, 6)
- (-4, 5) and (-4, -3)

7. $(-2, 3)$ and $(-2, -3)$
8. $(4, 1)$ and $(7, 1)$

For 9-10, determine if the statement is true or false.

9. If you know the slope of a line you will know whether it is pointing up or down from left to right.
10. Vertical lines have a slope of zero.

3.8 Parallel Lines in the Coordinate Plane

Here you'll learn that parallel lines have the same slope. You'll then apply this fact to determine if two lines are parallel and to find what their equations are.

What if you were given two parallel lines in the coordinate plane? What could you say about their slopes? After completing this Concept, you'll be able to answer this question. You'll also find the equations of parallel lines and determine if two lines are parallel based on their slopes.

Watch This



MEDIA

Click image to the left for more content.

[CK-12 Parallel Lines in the Coordinate Plane](#)

Guidance

Parallel lines are two lines that never intersect. In the coordinate plane, that would look like this:

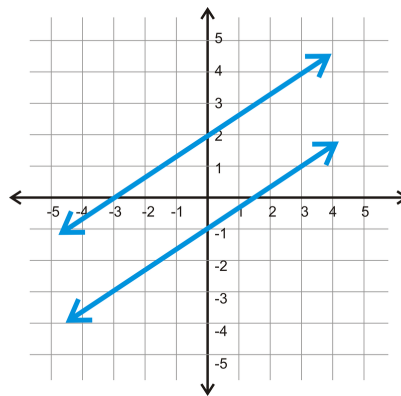

If we take a closer look at these two lines, the slopes are both $\frac{2}{3}$.

This can be generalized to any pair of parallel lines. **Parallel lines always have the same slope and different y-intercepts.**

Example A

Find the equation of the line that is parallel to $y = -\frac{1}{3}x + 4$ and passes through $(9, -5)$.

Recall that the equation of a line is $y = mx + b$, where m is the slope and b is the y-intercept. We know that parallel lines have the same slope, so the line will have a slope of $-\frac{1}{3}$. Now, we need to find the y-intercept. Plug in 9 for x and -5 for y to solve for the *new* y-intercept (b).

$$\begin{aligned} -5 &= -\frac{1}{3}(9) + b \\ -5 &= -3 + b \\ -2 &= b \end{aligned}$$

The equation of parallel line is $y = -\frac{1}{3}x - 2$.

Example B

Find the equation of the lines below and determine if they are parallel.

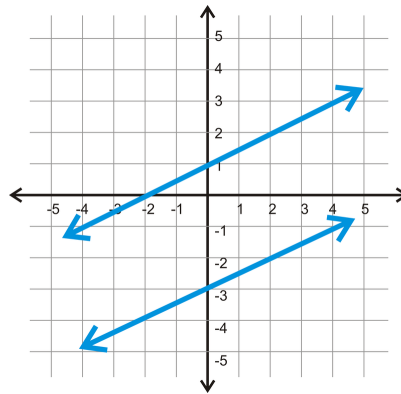

The top line has a y -intercept of 1. From there, use “rise over run” to find the slope. From the y -intercept, if you go up 1 and over 2, you hit the line again, $m = \frac{1}{2}$. The equation is $y = \frac{1}{2}x + 1$.

For the second line, the y -intercept is -3. The “rise” is 1 and the “run” is 2 making the slope $\frac{1}{2}$. The equation of this line is $y = \frac{1}{2}x - 3$.

The lines are **parallel** because they have the same slope.

Example C

Find the equation of the line that is parallel to the line through the point marked with a blue dot.

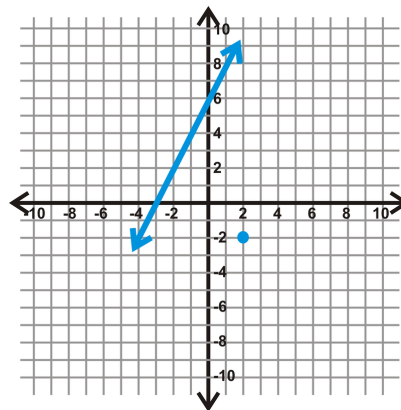

First, notice that the equation of the line is $y = 2x + 6$ and the point is $(2, -2)$. The parallel would have the same slope and pass through $(2, -2)$.

$$\begin{aligned}
 y &= 2x + b \\
 -2 &= 2(2) + b \\
 -2 &= 4 + b \\
 -6 &= b
 \end{aligned}$$

The equation of the parallel line is $y = 2x + -6$.



MEDIA

Click image to the left for more content.

CK-12 Parallel Lines in the Coordinate Plane

Guided Practice

1. Find the equation of the line that is parallel to $y = \frac{1}{4}x + 3$ and passes through $(8, -7)$.
2. Are the lines $y = 2x + 1$ and $y = 2x + 5$ parallel?
3. Are the lines $3x + 4y = 7$ and $y = \frac{3}{4}x + 1$ parallel?

Answers:

1. We know that parallel lines have the same slope, so the line will have a slope of $\frac{1}{4}$. Now, we need to find the y -intercept. Plug in 8 for x and -7 for y to solve for the *new* y -intercept (b).

$$\begin{aligned}
 -7 &= \frac{1}{4}(8) + b \\
 -7 &= 2 + b \\
 -9 &= b
 \end{aligned}$$

The equation of the parallel line is $y = \frac{1}{4}x - 9$.

2. Both equations are already in slope-intercept form and their slopes are both 2 so yes, the lines are parallel.
3. First we need to rewrite the first equation in slope-intercept form.

$$\begin{aligned}
 3x + 4y &= 7 \\
 4y &= -3x + 7 \\
 y &= -\frac{3}{4}x + \frac{7}{4}
 \end{aligned}$$

The slope of this line is $-\frac{3}{4}$ while the slope of the other line is $\frac{3}{4}$. Because the slopes are different the lines are not parallel.

Practice

Determine if each pair of lines are parallel. Then, graph each pair on the same set of axes.

1. $y = 4x - 2$ and $y = 4x + 5$
2. $y = -x + 5$ and $y = x + 1$
3. $5x + 2y = -4$ and $5x + 2y = 8$
4. $x + y = 6$ and $4x + 4y = -16$

Determine the equation of the line that is *parallel* to the given line, through the given point.

5. $y = -5x + 1$; $(-2, 3)$
6. $y = \frac{2}{3}x - 2$; $(9, 1)$
7. $x - 4y = 12$; $(-16, -2)$
8. $3x + 2y = 10$; $(8, -11)$

Find the equation of the two lines in each graph below. Then, determine if the two lines are parallel.

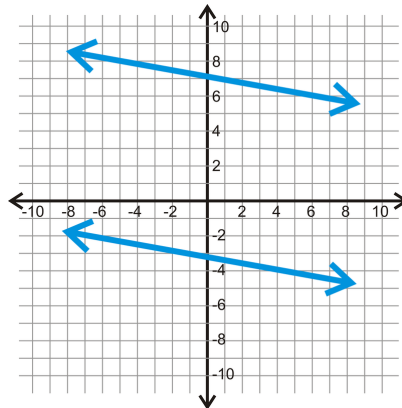

For the line and point below, find a parallel line, through the given point.

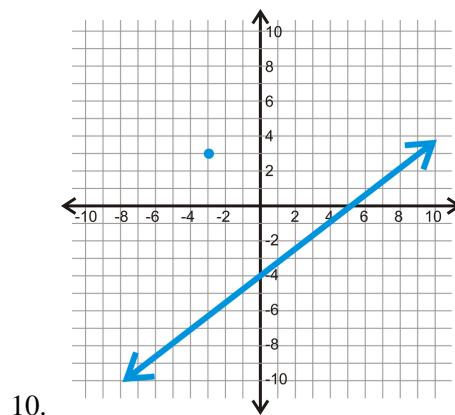

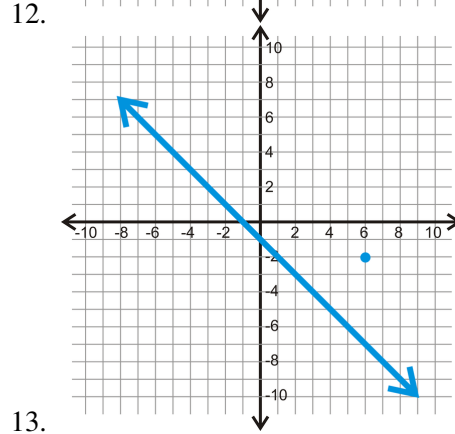
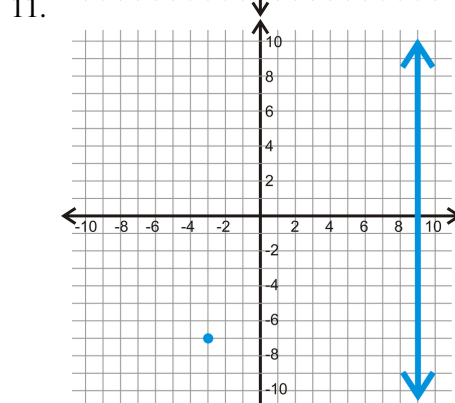
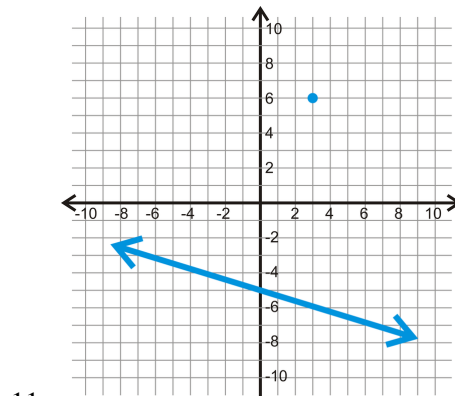

3.9 Perpendicular Lines in the Coordinate Plane

Here you'll learn that the slopes of perpendicular lines are negative reciprocals of each other. You'll then apply this fact to determine if two lines are perpendicular and to find what their equations are.

What if you were given two perpendicular lines in the coordinate plane? What could you say about their slopes? After completing this Concept, you'll be able to answer this question. You'll also find the equations of perpendicular lines and determine if two lines are perpendicular based on their slopes.

Watch This



MEDIA

Click image to the left for more content.

CK-12 Perpendicular Lines in the Coordinate Plane

Guidance

Perpendicular lines are two lines that intersect at a 90° , or right, angle. In the coordinate plane, that would look like this:

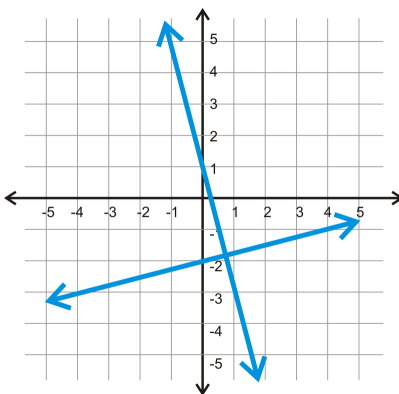

If we take a closer look at these two lines, the slope of one is -4 and the other is $\frac{1}{4}$.

This can be generalized to any pair of perpendicular lines in the coordinate plane. *The slopes of perpendicular lines are opposite reciprocals of each other.*

Example A

Find the equation of the line that is perpendicular to $y = -\frac{1}{3}x + 4$ and passes through $(9, -5)$.

First, the slope is the opposite reciprocal of $-\frac{1}{3}$. So, $m = 3$. Plug in 9 for x and -5 for y to solve for the *new* y -intercept (b).

$$\begin{aligned} -5 &= 3(9) + b \\ -5 &= 27 + b \\ -32 &= b \end{aligned}$$

Therefore, the equation of the perpendicular line is $y = 3x - 32$.

Example B

Graph $3x - 4y = 8$ and $4x + 3y = 15$. Determine if they are perpendicular.

First, we have to change each equation into slope-intercept form. In other words, we need to solve each equation for y .

$$\begin{aligned} 3x - 4y &= 8 \\ -4y &= -3x + 8 \\ y &= \frac{3}{4}x - 2 \end{aligned} \qquad \begin{aligned} 4x + 3y &= 15 \\ 3y &= -4x + 15 \\ y &= -\frac{4}{3}x + 5 \end{aligned}$$

Now that the lines are in slope-intercept form (also called y -intercept form), we can tell they are perpendicular because their slopes are opposite reciprocals.

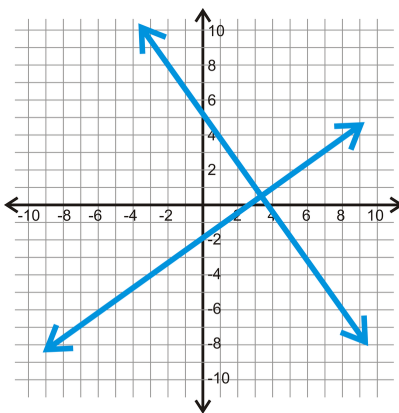

Example C

Find the equation of the line that is perpendicular to the line $y = 2x + 7$ and goes through the point $(2, -2)$.

The perpendicular line goes through $(2, -2)$, but the slope is $-\frac{1}{2}$ because we need to take the opposite reciprocal of 2.

$$\begin{aligned} y &= -\frac{1}{2}x + b \\ -2 &= -\frac{1}{2}(2) + b \\ -2 &= -1 + b \\ -1 &= b \end{aligned}$$

The equation is $y = -\frac{1}{2}x - 1$.



MEDIA

Click image to the left for more content.

CK-12 Perpendicular Lines in the Coordinate Plane

Guided Practice

Find the slope of the lines that are perpendicular to the lines below.

1. $y = 2x + 3$

2. $y = -\frac{2}{3}x - 5$

3. $y = x + 2$

Answers:

1. $m = 2$, so m_{\perp} is the opposite reciprocal, $m_{\perp} = -\frac{1}{2}$.

2. $m = -\frac{2}{3}$, take the reciprocal and change the sign, $m_{\perp} = \frac{3}{2}$.

3. Because there is no number in front of x , the slope is 1. The reciprocal of 1 is 1, so the only thing to do is make it negative, $m_{\perp} = -1$.

Practice

Determine if each pair of lines are perpendicular. Then, graph each pair on the same set of axes.

1. $y = -2x + 3$ and $y = \frac{1}{2}x + 3$

2. $y = -3x + 1$ and $y = 3x - 1$

3. $2x - 3y = 6$ and $3x + 2y = 6$

4. $x - 3y = -3$ and $x + 3y = 9$

Determine the equation of the line that is perpendicular to the given line, through the given point.

5. $y = x - 1$; $(-6, 2)$

6. $y = 3x + 4$; $(9, -7)$

7. $5x - 2y = 6$; $(5, 5)$

8. $y = 4$; $(-1, 3)$

Find the equations of the two lines in each graph below. Then, determine if the two lines are perpendicular.

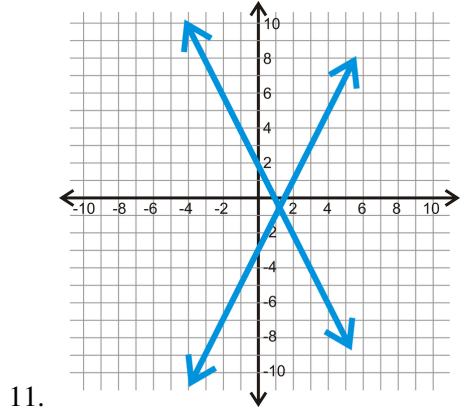
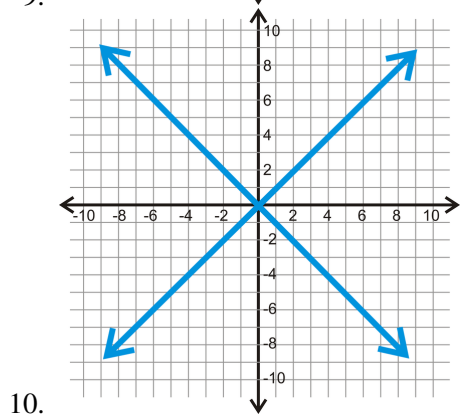
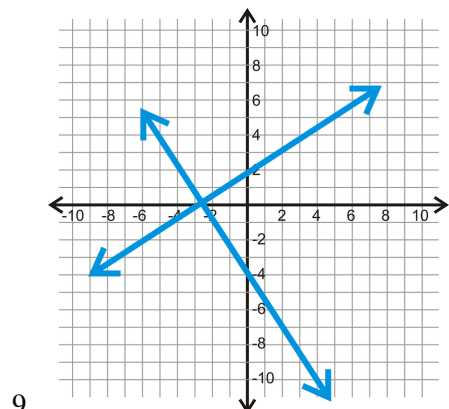

For the line and point below, find a perpendicular line through the given point.

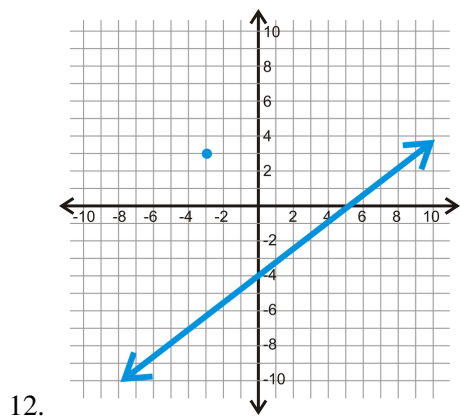

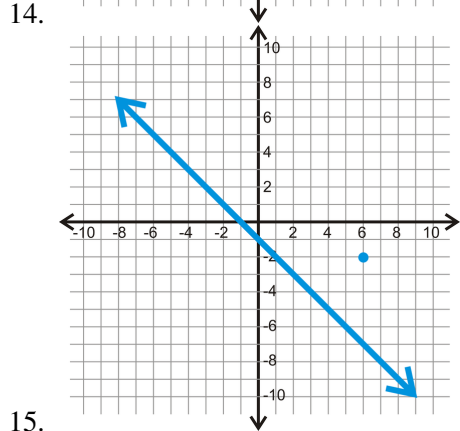
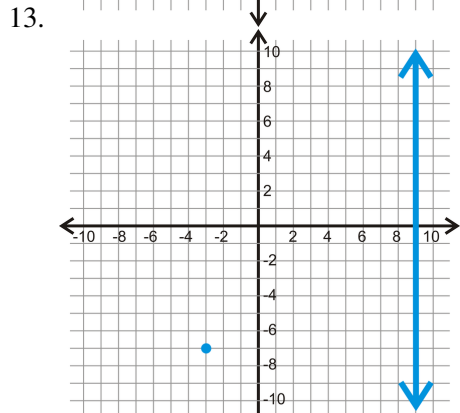
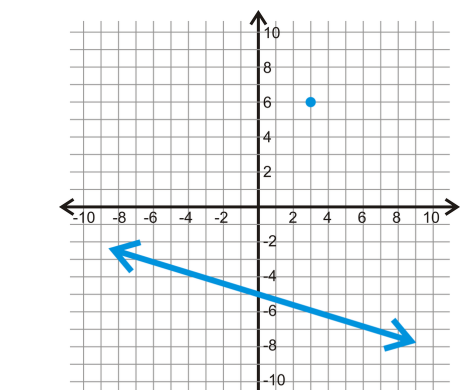

3.10 Distance Formula in the Coordinate Plane

Here you'll learn the Distance Formula and you'll use it to find the distance between two points.

What if you were given the coordinates of two points? How could you find how far apart these two points are? After completing this Concept, you'll be able to find the distance between two points in the coordinate plane using the Distance Formula.

Watch This



MEDIA

Click image to the left for more content.

CK-12 Finding The Distance Between Two Points

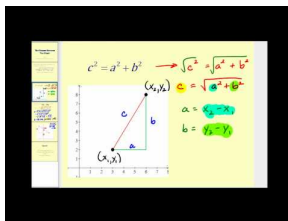

MEDIA

Click image to the left for more content.

James Sousa: The Distance Formula

Guidance

The distance between two points (x_1, y_1) and (x_2, y_2) can be defined as $d = \sqrt{(x_2 - x_1)^2 + (y_2 - y_1)^2}$. This is called the **distance formula**. Remember that distances are always positive!

Example A

Find the distance between $(4, -2)$ and $(-10, 3)$.

Plug in $(4, -2)$ for (x_1, y_1) and $(-10, 3)$ for (x_2, y_2) and simplify.

$$\begin{aligned}
 d &= \sqrt{(-10 - 4)^2 + (3 + 2)^2} \\
 &= \sqrt{(-14)^2 + (5)^2} \\
 &= \sqrt{196 + 25} \\
 &= \sqrt{221} \approx 14.87 \text{ units}
 \end{aligned}$$

Example B

Find the distance between (3, 4) and (-1, 3).

Plug in (3, 4) for (x_1, y_1) and (-1, 3) for (x_2, y_2) and simplify.

$$\begin{aligned} d &= \sqrt{(-1 - 3)^2 + (3 - 4)^2} \\ &= \sqrt{(-4)^2 + (-1)^2} \\ &= \sqrt{16 + 1} \\ &= \sqrt{17} \approx 4.12 \text{ units} \end{aligned}$$

Example C

Find the distance between (4, 23) and (8, 14).

Plug in (4, 23) for (x_1, y_1) and (8, 14) for (x_2, y_2) and simplify.

$$\begin{aligned} d &= \sqrt{(8 - 4)^2 + (14 - 23)^2} \\ &= \sqrt{(4)^2 + (-9)^2} \\ &= \sqrt{16 + 81} \\ &= \sqrt{97} \approx 9.85 \text{ units} \end{aligned}$$



MEDIA

Click image to the left for more content.

CK-12 Finding The Distance Between Two Points

Guided Practice

1. Find the distance between (-2, -3) and (3, 9).
2. Find the distance between (12, 26) and (8, 7)
3. Find the distance between (5, 2) and (6, 1)

Answers

1. Use the distance formula, plug in the points, and simplify.

$$\begin{aligned}d &= \sqrt{(3 - (-2))^2 + (9 - (-3))^2} \\&= \sqrt{(5)^2 + (12)^2} \\&= \sqrt{25 + 144} \\&= \sqrt{169} = 13 \text{ units}\end{aligned}$$

2. Use the distance formula, plug in the points, and simplify.

$$\begin{aligned}d &= \sqrt{(8 - 12)^2 + (7 - 26)^2} \\&= \sqrt{(-4)^2 + (-19)^2} \\&= \sqrt{16 + 361} \\&= \sqrt{377} \approx 19.42 \text{ units}\end{aligned}$$

3. Use the distance formula, plug in the points, and simplify.

$$\begin{aligned}d &= \sqrt{(6 - 5)^2 + (1 - 2)^2} \\&= \sqrt{(1)^2 + (-1)^2} \\&= \sqrt{1 + 1} \\&= \sqrt{2} = 1.41 \text{ units}\end{aligned}$$

Practice

Find the distance between each pair of points. Round your answer to the nearest hundredth.

1. (4, 15) and (-2, -1)
2. (-6, 1) and (9, -11)
3. (0, 12) and (-3, 8)
4. (-8, 19) and (3, 5)
5. (3, -25) and (-10, -7)
6. (-1, 2) and (8, -9)
7. (5, -2) and (1, 3)
8. (-30, 6) and (-23, 0)
9. (2, -2) and (2, 5)
10. (-9, -4) and (1, -1)

3.11 Distance Between Parallel Lines

Here you'll learn that the shortest distance between two parallel lines is the length of a perpendicular line between them.

What if you were given two parallel lines? How could you find how far apart these two lines are? After completing this Concept, you'll be able to find the distance between two vertical lines, two horizontal lines, and two non-vertical, non-horizontal parallel lines using the perpendicular slope.

Watch This



MEDIA

Click image to the left for more content.

CK-12 Finding The Distance Between Parallel Lines

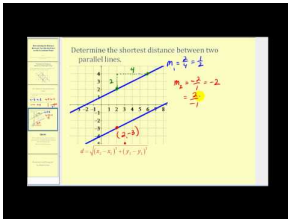

MEDIA

Click image to the left for more content.

James Sousa: Determining the Distance Between Two Parallel Lines

Guidance

All vertical lines are in the form $x = a$, where a is the x -intercept. To find the distance between two vertical lines, count the squares between the two lines. You can use this method for horizontal lines as well. All horizontal lines are in the form $y = b$, where b is the y -intercept.

In general, the shortest distance between two parallel lines is the length of a perpendicular line between them. There are infinitely many perpendicular lines between two parallel lines, but they will all be the same length.

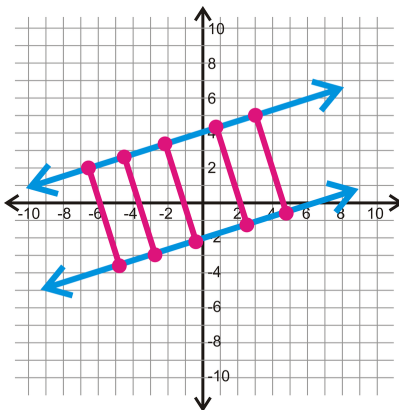

Remember that distances are always positive!

Example A

Find the distance between $x = 3$ and $x = -5$.

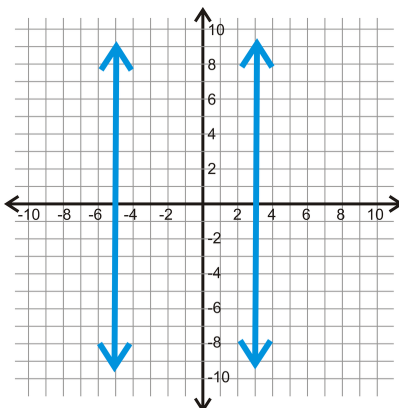

The two lines are $3 - (-5)$ units apart, or 8 units apart.

Example B

Find the distance between $y = 5$ and $y = -8$.

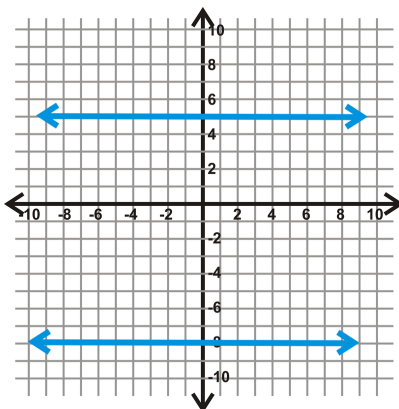

The two lines are $5 - (-8)$ units apart, or 13 units apart.

Example C

Find the distance between $y = x + 6$ and $y = x - 2$.

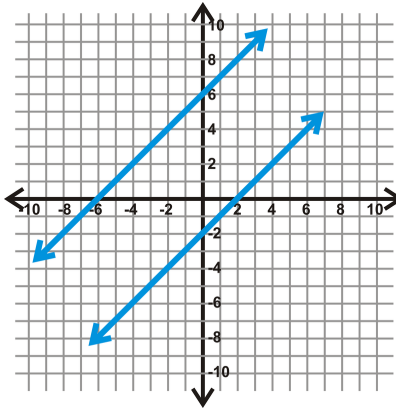

Step 1: Find the perpendicular slope.

$$m = 1, \text{ so } m_{\perp} = -1$$

Step 2: Find the y -intercept of the top line, $y = x + 6$. $(0, 6)$

Step 3: Use the slope and count down 1 and to the right 1 until you hit $y = x - 2$.

Always rise/run the same amount for $m = 1$ or -1 .

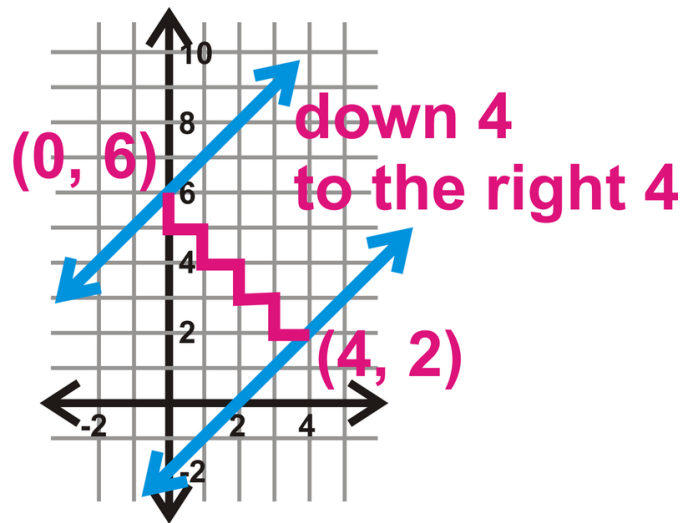

Step 4: Use these two points in the distance formula to determine how far apart the lines are.

$$\begin{aligned} d &= \sqrt{(0-4)^2 + (6-2)^2} \\ &= \sqrt{(-4)^2 + (4)^2} \\ &= \sqrt{16+16} \\ &= \sqrt{32} = 5.66 \text{ units} \end{aligned}$$



MEDIA

Click image to the left for more content.

CK-12 Finding The Distance Between Parallel Lines

Guided Practice

1. Find the distance between $y = -x - 1$ and $y = -x - 3$.

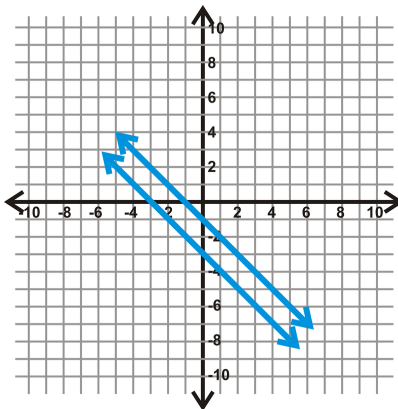

2. Find the distance between $y = 2$ and $y = -4$.
 3. Find the distance between $x = -5$ and $x = -10$.

Answers:

1. Step 1: Find the perpendicular slope.

$$m = -1, \text{ so } m_{\perp} = 1$$

Step 2: Find the y -intercept of the top line, $y = -x - 1$. $(0, -1)$

Step 3: Use the slope and count down 1 and to the *left* 1 until you hit $y = x - 3$.



Step 4: Use these two points in the distance formula to determine how far apart the lines are.

$$\begin{aligned} d &= \sqrt{(0 - (-1))^2 + (-1 - (-2))^2} \\ &= \sqrt{(1)^2 + (1)^2} \\ &= \sqrt{1 + 1} \\ &= \sqrt{2} = 1.41 \text{ units} \end{aligned}$$

- The two lines are $2 - (-4)$ units apart, or 6 units apart.
- The two lines are $-5 - (-10)$ units apart, or 5 units apart.

Practice

Use each graph below to determine how far apart each pair of parallel lines is.

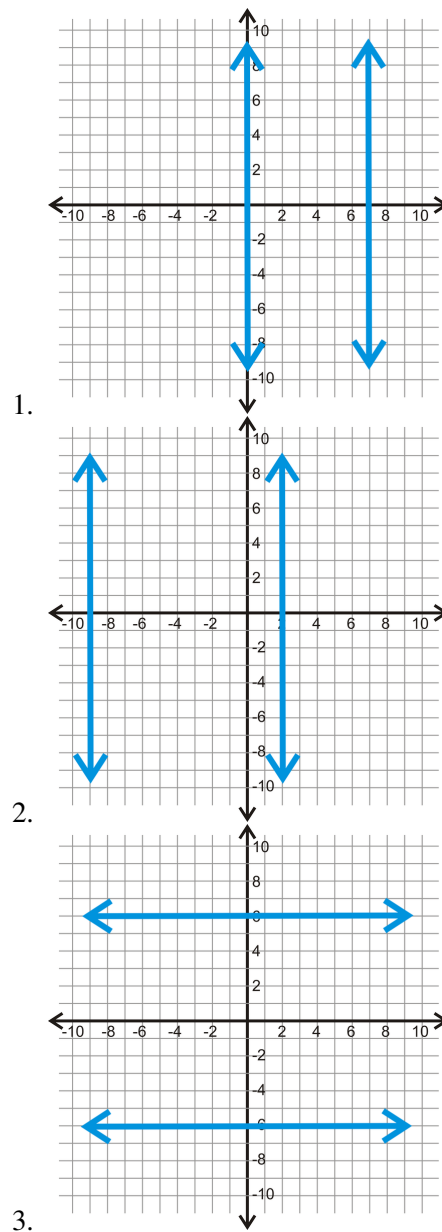

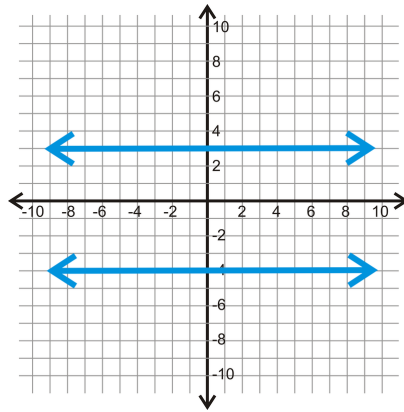

4.

Determine the shortest distance between the each pair of parallel lines. Round your answer to the nearest hundredth.

5. $x = 5, x = 1$
6. $y = -6, y = 4$
7. $y = 3, y = 15$
8. $x = -10, x = -1$
9. $x = 8, x = 0$
10. $y = 7, y = -12$

Find the distance between the given parallel lines.

11. $y = x - 3, y = x + 11$
12. $y = -x + 4, y = -x$
13. $y = -x - 5, y = -x + 1$
14. $y = x + 12, y = x - 6$

Summary

This chapter begins by comparing parallel and skew lines and presenting some of the basic properties of parallel lines. Perpendicular lines are then introduced and some basic properties and theorems related to perpendicular lines are explored. Building on the discussion of parallel lines, perpendicular lines, and transversals, the different angles formed when parallel lines are cut by a transversal are displayed. Corresponding angles, alternate interior angles, alternate exterior angles and their properties are presented. The algebra topics of equations of lines, slope, and distance are tied to the geometric concepts of parallel and perpendicular lines.

Chapter Outline

- 4.1 TRIANGLE SUM THEOREM
 - 4.2 EXTERIOR ANGLES THEOREMS
 - 4.3 CONGRUENT TRIANGLES
 - 4.4 CONGRUENCE STATEMENTS
 - 4.5 THIRD ANGLE THEOREM
 - 4.6 SSS TRIANGLE CONGRUENCE
 - 4.7 SAS TRIANGLE CONGRUENCE
 - 4.8 ASA AND AAS TRIANGLE CONGRUENCE
 - 4.9 HL TRIANGLE CONGRUENCE
 - 4.10 ISOSCELES TRIANGLES
 - 4.11 EQUILATERAL TRIANGLES
-

Introduction

In this chapter, you will learn all about triangles. First, we will find out how many degrees are in a triangle and other properties of the angles within a triangle. Second, we will use that information to determine if two different triangles are congruent. Finally, we will investigate the properties of isosceles and equilateral triangles.

4.1 Triangle Sum Theorem

Here you'll learn how to use the Triangle Sum Theorem, which states that the sum of the angles in any triangle is 180° .

What if you knew that two of the angles in a triangle measured 55° ? How could you find the measure of the third angle? After completing this Concept, you'll be able to apply the Triangle Sum Theorem to solve problems like this one.

Watch This



MEDIA

Click image to the left for more content.

CK-12 Triangle Sum Theorem

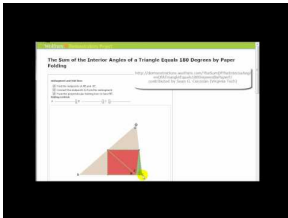

MEDIA

Click image to the left for more content.

James Sousa: Animation of the Sum of the Interior Angles of a Triangle

Now watch this video.

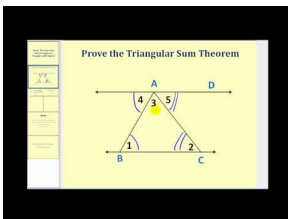

MEDIA

Click image to the left for more content.

James Sousa: Proving the Triangle Sum Theorem

Guidance

The **Triangle Sum Theorem** says that the three interior angles of any triangle add up to 180° .

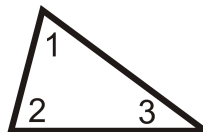

$$m\angle 1 + m\angle 2 + m\angle 3 = 180^\circ$$

Here is one proof of the Triangle Sum Theorem.

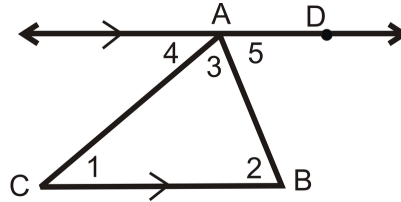

Given: $\triangle ABC$ with $\overleftrightarrow{AD} \parallel \overline{BC}$

Prove: $m\angle 1 + m\angle 2 + m\angle 3 = 180^\circ$

TABLE 4.1:

Statement

1. $\triangle ABC$ with $\overleftrightarrow{AD} \parallel \overline{BC}$
2. $\angle 1 \cong \angle 4$, $\angle 2 \cong \angle 5$
3. $m\angle 1 = m\angle 4$, $m\angle 2 = m\angle 5$
4. $m\angle 4 + m\angle CAD = 180^\circ$
5. $m\angle 3 + m\angle 5 = m\angle CAD$
6. $m\angle 4 + m\angle 3 + m\angle 5 = 180^\circ$
7. $m\angle 1 + m\angle 3 + m\angle 2 = 180^\circ$

Reason

- Given
 Alternate Interior Angles Theorem
 \cong angles have = measures
 Linear Pair Postulate
 Angle Addition Postulate
 Substitution PoE
 Substitution PoE

You can use the Triangle Sum Theorem to find missing angles in triangles.

Example A

What is $m\angle T$?

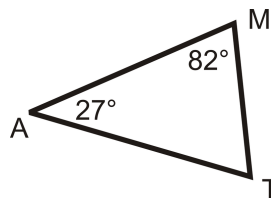

We know that the three angles in the triangle must add up to 180° . To solve this problem, set up an equation and substitute in the information you know.

$$\begin{aligned} m\angle M + m\angle A + m\angle T &= 180^\circ \\ 82^\circ + 27^\circ + m\angle T &= 180^\circ \\ 109^\circ + m\angle T &= 180^\circ \\ m\angle T &= 71^\circ \end{aligned}$$

Example B

What is the measure of each angle in an equiangular triangle?

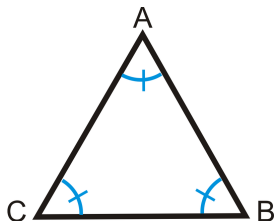

To solve, remember that $\triangle ABC$ is an equiangular triangle, so all three angles are equal. Write an equation.

$$m\angle A + m\angle B + m\angle C = 180^\circ$$

$$m\angle A + m\angle A + m\angle A = 180^\circ \quad \textit{Substitute, all angles are equal.}$$

$$3m\angle A = 180^\circ \quad \textit{Combine like terms.}$$

$$m\angle A = 60^\circ$$

If $m\angle A = 60^\circ$, then $m\angle B = 60^\circ$ and $m\angle C = 60^\circ$.

Each angle in an equiangular triangle is 60° .

Example C

Find the measure of the missing angle.

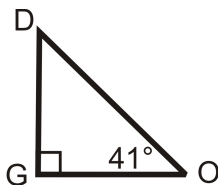

We know that $m\angle O = 41^\circ$ and $m\angle G = 90^\circ$ because it is a right angle. Set up an equation like in Example A.

$$m\angle D + m\angle O + m\angle G = 180^\circ$$

$$m\angle D + 41^\circ + 90^\circ = 180^\circ$$

$$m\angle D + 41^\circ = 90^\circ$$

$$m\angle D = 49^\circ$$



MEDIA

Click image to the left for more content.

Guided Practice

1. Determine $m\angle 1$ in this triangle:

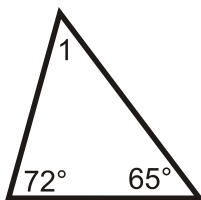

2. Two interior angles of a triangle measure 50° and 70° . What is the third interior angle of the triangle?

3. Find the value of x and the measure of each angle.

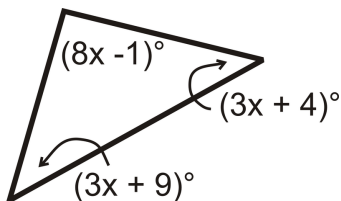
**Answers:**

1. $72^\circ + 65^\circ + m\angle 1 = 180^\circ$.

Solve this equation and you find that $m\angle 1 = 43^\circ$.

2. $50^\circ + 70^\circ + x = 180^\circ$.

Solve this equation and you find that the third angle is 60° .

3. All the angles add up to 180° .

$$(8x - 1)^\circ + (3x + 9)^\circ + (3x + 4)^\circ = 180^\circ$$

$$(14x + 12)^\circ = 180^\circ$$

$$14x = 168$$

$$x = 12$$

Substitute in 12 for x to find each angle.

$$[3(12) + 9]^\circ = 45^\circ$$

$$[3(12) + 4]^\circ = 40^\circ$$

$$[8(12) - 1]^\circ = 95^\circ$$

Practice

Determine $m\angle 1$ in each triangle.

1.



2.

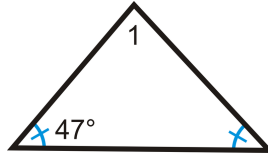

3.

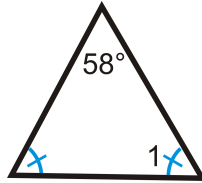

4.

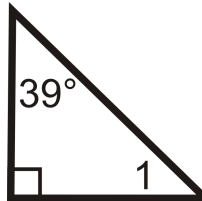

5.

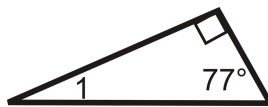

6.

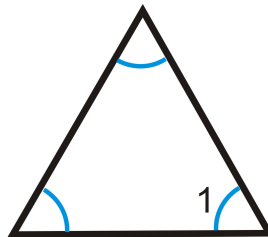

7.



8. Two interior angles of a triangle measure 32° and 64° . What is the third interior angle of the triangle?

9. Two interior angles of a triangle measure 111° and 12° . What is the third interior angle of the triangle?

10. Two interior angles of a triangle measure 2° and 157° . What is the third interior angle of the triangle?

Find the value of x and the measure of each angle.

11.

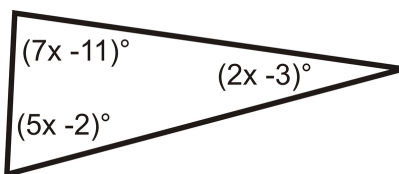

12.

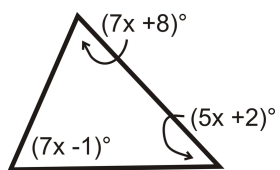

13.

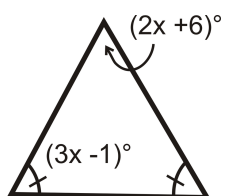

14.

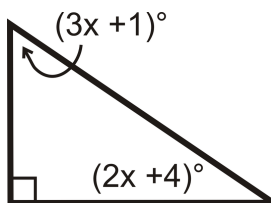

15.

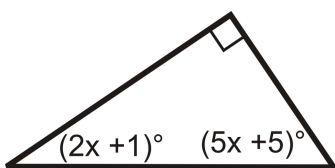

4.2 Exterior Angles Theorems

Here you'll learn what an exterior angle is as well as two theorems involving exterior angles: that the sum of the exterior angles is always 360° and that in a triangle, an exterior angle is equal to the sum of its remote interior angles.

What if you knew that two of the exterior angles of a triangle measured 130° ? How could you find the measure of the third exterior angle? After completing this Concept, you'll be able to apply the Exterior Angle Sum Theorem to solve problems like this one.

Watch This



MEDIA

Click image to the left for more content.

CK-12 Exterior Angles Theorems

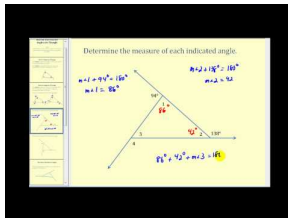

MEDIA

Click image to the left for more content.

James Sousa: Introduction to the Exterior Angles of a Triangle

Then watch this video.

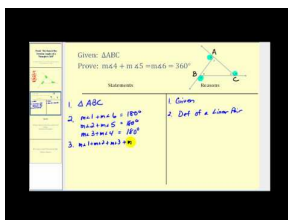

MEDIA

Click image to the left for more content.

James Sousa: Proof that the Sum of the Exterior Angles of a Triangle is 360 Degrees

Finally, watch this video.

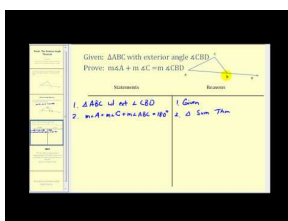

MEDIA

Click image to the left for more content.

James Sousa:Proof of the Exterior Angles Theorem

Guidance

An **Exterior Angle** is the angle formed by one side of a polygon and the extension of the adjacent side.

In all polygons, there are **two** sets of exterior angles, one that goes around clockwise and the other goes around counterclockwise.

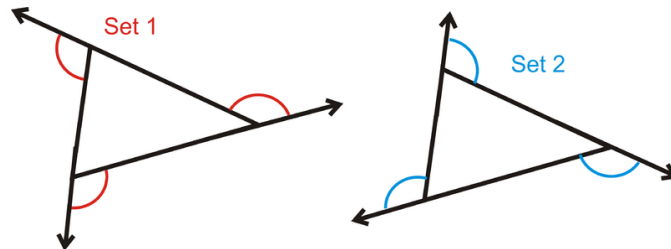

Notice that the interior angle and its adjacent exterior angle form a linear pair and add up to 180° .

$$m\angle 1 + m\angle 2 = 180^\circ$$

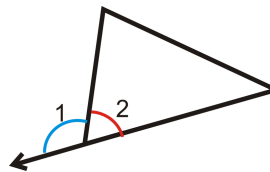

There are two important theorems to know involving exterior angles: the Exterior Angle Sum Theorem and the Exterior Angle Theorem.

The **Exterior Angle Sum Theorem** states that the exterior angles of any polygon will always add up to 360° .

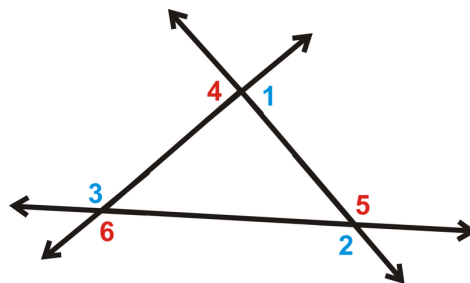

$$m\angle 1 + m\angle 2 + m\angle 3 = 360^\circ$$

$$m\angle 4 + m\angle 5 + m\angle 6 = 360^\circ$$

The **Exterior Angle Theorem** states that an exterior angle of a triangle is equal to the sum of its remote interior angles. (**Remote Interior Angles** are the two interior angles in a triangle that are not adjacent to the indicated exterior angle.)

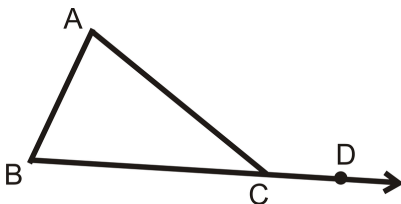

$$m\angle A + m\angle B = m\angle ACD$$

Example A

Find the measure of $\angle RQS$.

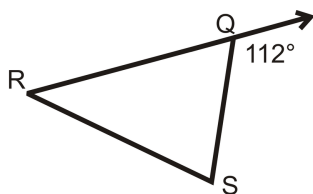

Notice that 112° is an exterior angle of $\triangle RQS$ and is supplementary to $\angle RQS$.

Set up an equation to solve for the missing angle.

$$\begin{aligned} 112^\circ + m\angle RQS &= 180^\circ \\ m\angle RQS &= 68^\circ \end{aligned}$$

Example B

Find the measures of the numbered interior and exterior angles in the triangle.

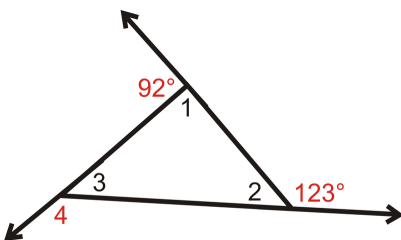

We know that $m\angle 1 + 92^\circ = 180^\circ$ because they form a linear pair. So, $m\angle 1 = 88^\circ$.

Similarly, $m\angle 2 + 123^\circ = 180^\circ$ because they form a linear pair. So, $m\angle 2 = 57^\circ$.

We also know that the three interior angles must add up to 180° by the Triangle Sum Theorem.

$$\begin{aligned} m\angle 1 + m\angle 2 + m\angle 3 &= 180^\circ && \text{by the Triangle Sum Theorem.} \\ 88^\circ + 57^\circ + m\angle 3 &= 180^\circ \\ m\angle 3 &= 35^\circ \end{aligned}$$

$$\begin{aligned}\text{Lastly, } m\angle 3 + m\angle 4 &= 180^\circ && \text{because they form a linear pair.} \\ 35^\circ + m\angle 4 &= 180^\circ \\ m\angle 4 &= 145^\circ\end{aligned}$$

Example C

What is the value of p in the triangle below?

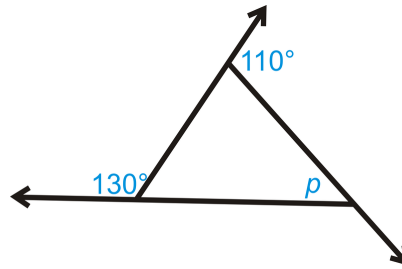

First, we need to find the missing exterior angle, which we will call x . Set up an equation using the Exterior Angle Sum Theorem.

$$\begin{aligned}130^\circ + 110^\circ + x &= 360^\circ \\ x &= 360^\circ - 130^\circ - 110^\circ \\ x &= 120^\circ\end{aligned}$$

x and p add up to 180° because they are a linear pair.

$$\begin{aligned}x + p &= 180^\circ \\ 120^\circ + p &= 180^\circ \\ p &= 60^\circ\end{aligned}$$



MEDIA

Click image to the left for more content.

[CK-12 Exterior Angles Theorems](#)

Guided Practice

1. Find $m\angle C$.

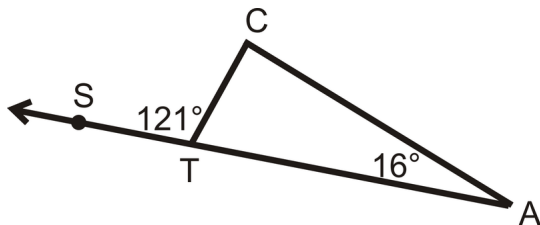

- Two interior angles of a triangle are 40° and 73° . What are the measures of the three exterior angles of the triangle?
- Find the value of x and the measure of each angle.

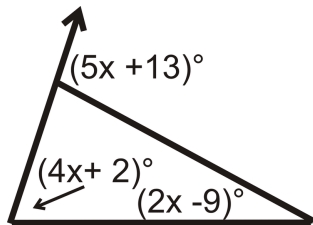

Answers:

- Using the Exterior Angle Theorem

$$m\angle C + 16^\circ = 121^\circ$$

$$m\angle C = 105^\circ$$

If you forget the Exterior Angle Theorem, you can do this problem just like Example C.

2. Remember that every interior angle forms a linear pair (adds up to 180°) with an exterior angle. So, since one of the interior angles is 40° that means that one of the exterior angles is 140° (because $40 + 140 = 180$). Similarly, since another one of the interior angles is 73° , one of the exterior angles must be 107° . The third interior angle is not given to us, but we could figure it out using the Triangle Sum Theorem. We can also use the Exterior Angle Sum Theorem. If two of the exterior angles are 140° and 107° , then the third Exterior Angle must be 113° since $140 + 107 + 113 = 360$.

So, the measures of the three exterior angles are 140, 107 and 113.

- Set up an equation using the Exterior Angle Theorem.

$$(4x + 2)^\circ + (2x - 9)^\circ = (5x + 13)^\circ$$

\uparrow \nearrow \uparrow
 remote interior angles exterior angle

$$(6x - 7)^\circ = (5x + 13)^\circ$$

$$x = 20$$

Substitute in 20 for x to find each angle.

$$[4(20) + 2]^\circ = 82^\circ \qquad [2(20) - 9]^\circ = 31^\circ \qquad \text{Exterior angle: } [5(20) + 13]^\circ = 113^\circ$$

Practice

Determine $m\angle 1$.

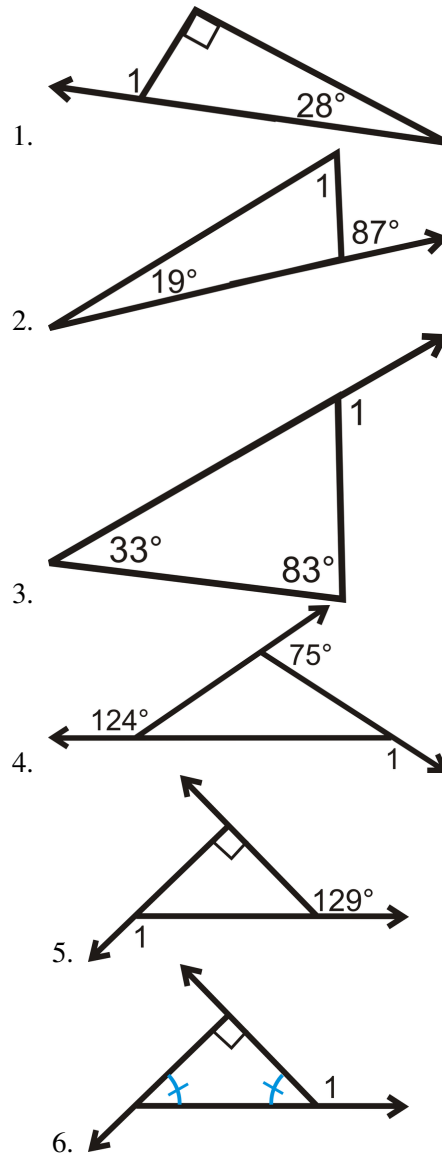

Use the following picture for the next three problems:

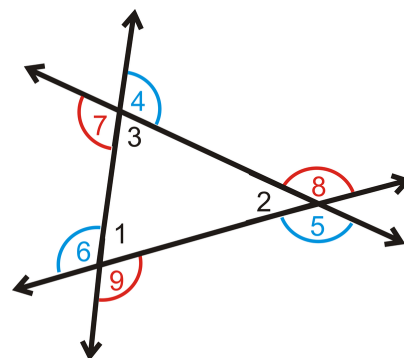

7. What is $m\angle 1 + m\angle 2 + m\angle 3$?

8. What is $m\angle 4 + m\angle 5 + m\angle 6$?
9. What is $m\angle 7 + m\angle 8 + m\angle 9$?

Solve for x .

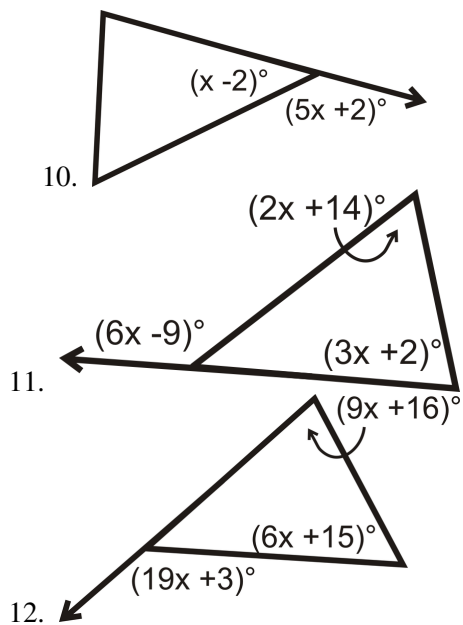

4.3 Congruent Triangles

Here you'll learn that two triangles are congruent if they have exactly the same size and shape. You'll then use this fact to determine if two triangles are congruent.

What if you were given two triangles with all the angle measures and all the side lengths marked? How could you tell if the two triangles were congruent? After completing this Concept, you'll be able to compare two triangles and decide whether they have exactly the same size and shape.

Watch This



MEDIA

Click image to the left for more content.

CK-12 Congruent Triangles

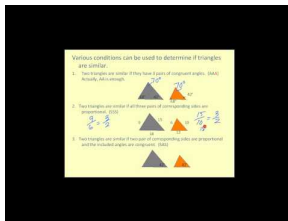

MEDIA

Click image to the left for more content.

James Sousa: Congruent Triangles

Guidance

Two figures are congruent if they have exactly the same size and shape. If two triangles are congruent, they will have exactly the same three sides and exactly the same three angles. In other words, two triangles are congruent if you can turn, flip, and/or slide one so it fits exactly on the other.

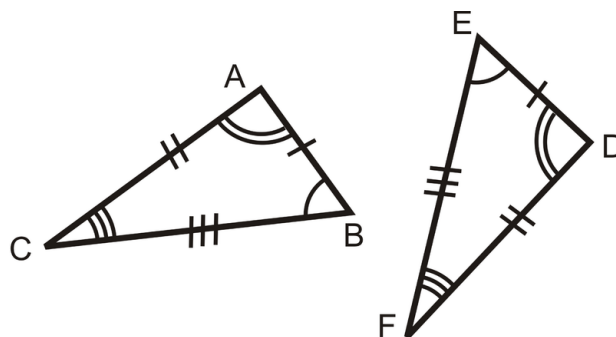

$\triangle ABC$ and $\triangle DEF$ are congruent because

$$\overline{AB} \cong \overline{DE} \quad \angle A \cong \angle D$$

$$\overline{BC} \cong \overline{EF} \text{ and } \angle B \cong \angle E$$

$$\overline{AC} \cong \overline{DF} \quad \angle C \cong \angle F$$

Notice that when two triangles are congruent their three pairs of corresponding angles and their three pairs of corresponding sides are congruent.

When referring to corresponding congruent parts of congruent triangles, you can use the phrase **Corresponding Parts of Congruent Triangles are Congruent**, or its abbreviation **CPCTC**.

Example A

Are the two triangles below congruent?

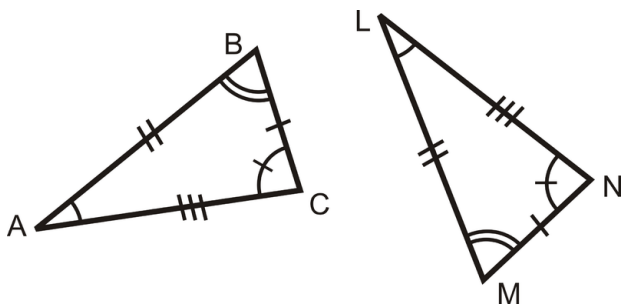

To determine if the triangles are congruent, match up sides with the same number of tic marks: $\overline{BC} \cong \overline{MN}$, $\overline{AB} \cong \overline{LM}$, $\overline{AC} \cong \overline{LN}$.

Next match up the angles with the same markings:

$$\angle A \cong \angle L, \angle B \cong \angle M, \text{ and } \angle C \cong \angle N.$$

Lastly, we need to make sure these are *corresponding* parts. To do this, check to see if the congruent angles are opposite congruent sides. Here, $\angle A$ is opposite \overline{BC} and $\angle L$ is opposite \overline{MN} . Because $\angle A \cong \angle L$ and $\overline{BC} \cong \overline{MN}$, they are corresponding. Doing this check for the other sides and angles, we see that everything matches up and the two triangles are congruent.

Example B

If all three pairs of angles for two given triangles are congruent does that mean that the triangles are congruent?

Without knowing anything about the lengths of the sides you cannot tell whether or not two triangles are congruent. The two triangles described above *might* be congruent, but we would need more information to know for sure.

Example C

Determine if the triangles are congruent using the definition of congruent triangles.

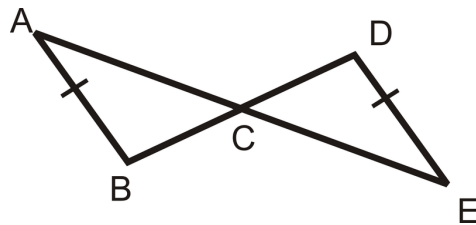

From the tic marks we can see that $\overline{AB} \cong \overline{DE}$. We also know that $\angle ACB \cong \angle ECD$ because they are vertical angles. However, this is not enough information to know whether or not the triangles are congruent.



MEDIA

Click image to the left for more content.

CK-12 Congruent Triangles

Guided Practice

- Determine if the triangles are congruent using the definition of congruent triangles.

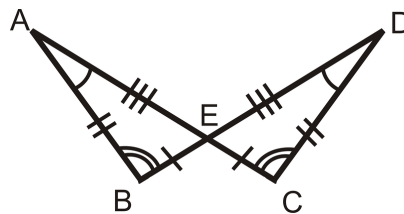

- Determine if the triangles are congruent using the definition of congruent triangles.

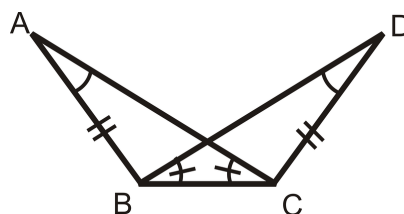

- Determine if the triangles are congruent using the definition of congruent triangles.

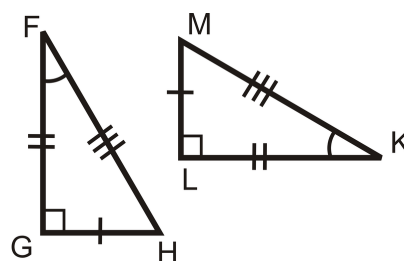

Answers:

1. We can see from the markings that $\angle B \cong \angle C$, $\angle A \cong \angle D$, and $\angle AEB \cong \angle DEC$ because they are vertical angles. Also, we know that $\overline{BA} \cong \overline{CD}$, $\overline{EA} \cong \overline{ED}$, and $\overline{BE} \cong \overline{CE}$. Because three pairs of sides and three pairs of angles are all congruent and they are corresponding parts, this means that the two triangles are congruent.
2. While there are congruent corresponding parts, there are only two pairs of congruent sides, the marked ones and the shared side. Without knowing whether or not the third pair of sides is congruent we cannot say if the triangles are congruent using the definition of congruent triangles. Note, this does not mean that the triangles are **not congruent**, it just means that we need more information in order to say they are congruent using the *definition of congruent triangles* (congruent triangles have three pairs of congruent angles and three pairs of congruent sides).
3. We can see from the markings that $\angle G \cong \angle L$, $\angle F \cong \angle K$, and therefore $\angle H \cong \angle M$ by the Third Angle Theorem. Also, we know that $\overline{MK} \cong \overline{FH}$, $\overline{GF} \cong \overline{LK}$, and $\overline{GH} \cong \overline{LM}$. Because three pairs of sides and three pairs of angles are all congruent and they are corresponding parts, this means that the two triangles are congruent.

Practice

The following illustrations show two parallel lines cut by a transversal. Are the triangles formed by them definitively congruent?

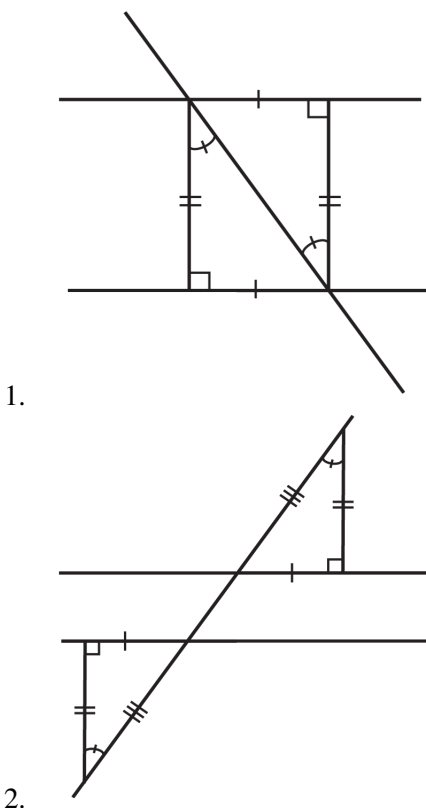

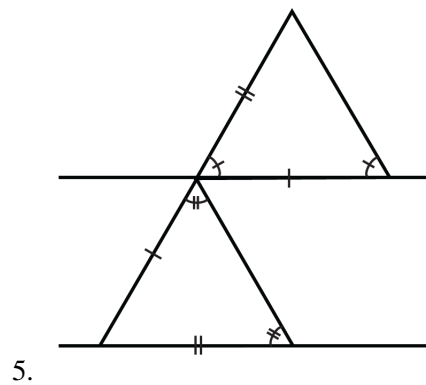
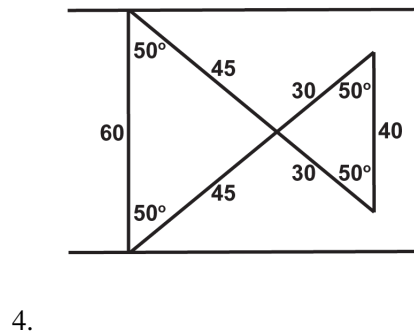
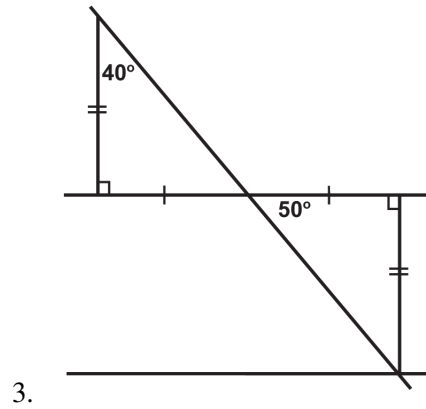

Based on the following details, are the triangles definitively congruent?

6. Both triangles are right triangles in which one angle measures 55° . All of their corresponding sides are congruent.
7. Both triangles are equiangular triangles.
8. Both triangles are equilateral triangles. All sides are 5 inches in length.
9. Both triangles are obtuse triangles in which one angle measures 35° . Two of their corresponding sides are congruent.
10. Both triangles are obtuse triangles in which two of their angles measure 40° and 20° . All of their corresponding sides are congruent.
11. Both triangles are isosceles triangles in which one angle measures 15° .
12. Both triangles are isosceles triangles with two equal angles of 55° . All corresponding sides are congruent.
13. Both triangles are acute triangles in which two of their angles measure 40° and 80° . All of their corresponding sides are congruent.
14. Both triangles are acute triangles in which one angle measures 60° . Two of their corresponding sides are congruent.
15. Both triangles are equilateral triangles.

4.4 Congruence Statements

Here you'll learn how to write congruence statements that show which sides and angles of congruent triangles are congruent.

What if you were told that

$$\triangle FGH \cong \triangle XYZ$$

? How could you determine which side in $\triangle XYZ$ is congruent to \overline{GH} and which angle is congruent to $\angle F$? After completing this Concept, you'll be able to state which sides and angles are congruent in congruent triangles.

Watch This



MEDIA

Click image to the left for more content.

CK-12 Creating Congruence Statements

Watch the first part of this video.

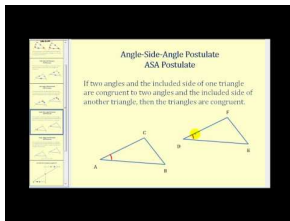

MEDIA

Click image to the left for more content.

James Sousa: Introduction to Congruent Triangles

Guidance

When stating that two triangles are congruent, the corresponding parts must be written in the same order. For example, if we know that $\triangle ABC$ and $\triangle LMN$ are congruent then we know that:

$$\begin{array}{l} \angle A \text{ and } \angle L \text{ are } \cong \quad \angle C \text{ and } \angle N \text{ are } \cong \\ \triangle ABC \cong \triangle LMN \\ \angle B \text{ and } \angle M \text{ are } \cong \end{array}$$

Notice that the congruent sides also line up within the congruence statement.

$$\overline{AB} \cong \overline{LM}, \overline{BC} \cong \overline{MN}, \overline{AC} \cong \overline{LN}$$

We can also write this congruence statement five other ways, as long as the congruent angles match up. For example, we can also write $\triangle ABC \cong \triangle LMN$ as:

$$\triangle ACB \cong \triangle LNM$$

$$\triangle BCA \cong \triangle MNL$$

$$\triangle BAC \cong \triangle MLN$$

$$\triangle CBA \cong \triangle NML$$

$$\triangle CAB \cong \triangle NLM$$

Example A

Write a congruence statement for the two triangles below.

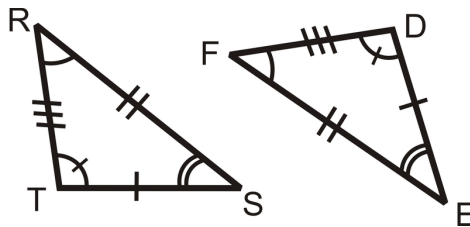

Line up the corresponding angles in the triangles:

$$\angle R \cong \angle F, \angle S \cong \angle E, \text{ and } \angle T \cong \angle D.$$

Therefore, one possible congruence statement is $\triangle RST \cong \triangle FED$

Example B

If $\triangle CAT \cong \triangle DOG$, what else do you know?

From this congruence statement, we know three pairs of angles and three pairs of sides are congruent.



Example C

If $\triangle BUG \cong \triangle ANT$, what angle is congruent to $\angle N$?

Since the order of the letters in the congruence statement tells us which angles are congruent, $\angle N \cong \angle U$ because they are each the second of the three letters.



MEDIA

Click image to the left for more content.

CK-12 Creating Congruence Statements

Guided Practice

1. If $\triangle ABC \cong \triangle DEF$, what else do you know?
2. If $\triangle KBP \cong \triangle MRS$, what else do you know?
3. If $\triangle EWN \cong \triangle MAP$, what else do you know?

Answers:

1. From this congruence statement, we know three pairs of angles and three pairs of sides are congruent. $\angle A \cong \angle D, \angle B \cong \angle E, \angle C \cong \angle F, \overline{AB} \cong \overline{DE}, \overline{BC} \cong \overline{EF}, \overline{AC} \cong \overline{DF}$.
2. From this congruence statement, we know three pairs of angles and three pairs of sides are congruent. $\angle K \cong \angle M, \angle B \cong \angle R, \angle P \cong \angle S, \overline{KB} \cong \overline{MR}, \overline{BP} \cong \overline{RS}, \overline{KP} \cong \overline{MS}$.
3. From this congruence statement, we know three pairs of angles and three pairs of sides are congruent. $\angle E \cong \angle M, \angle W \cong \angle A, \angle N \cong \angle P, \overline{EW} \cong \overline{MA}, \overline{WN} \cong \overline{AP}, \overline{EN} \cong \overline{MP}$.

Practice

For questions 1-4, determine if the triangles are congruent using the definition of congruent triangles. If they are, write the congruence statement.

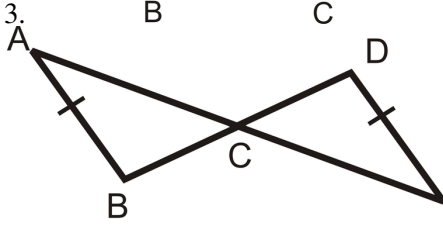
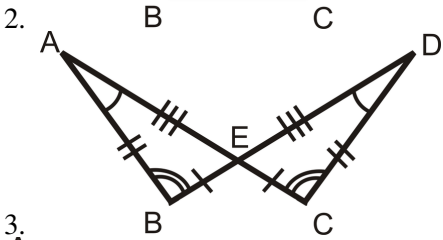
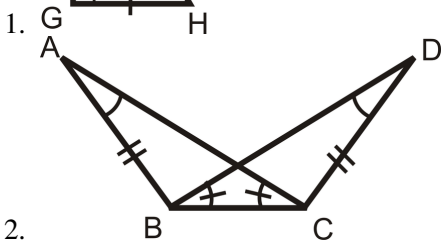
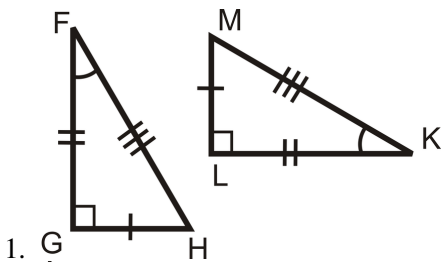

5. Suppose the two triangles to the right are congruent. Write a congruence statement for these triangles.

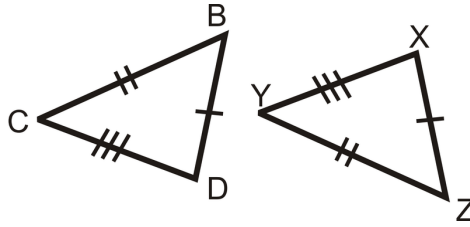

6. Explain how we know that if the two triangles are congruent, then $\angle B \cong \angle Z$.
7. If $\triangle TBS \cong \triangle FAM$, what else do you know?
8. If $\triangle PAM \cong \triangle STE$, what else do you know?
9. If $\triangle INT \cong \triangle WEB$, what else do you know?
10. If $\triangle ADG \cong \triangle BCE$, what angle is congruent to $\angle G$?

4.5 Third Angle Theorem

Here you'll learn the Third Angle Theorem: If two triangles have two pairs of angles that are congruent, then the third pair of angles will be congruent.

What if you were given $\triangle FGH$ and $\triangle XYZ$ and you were told that

$$\angle F \cong \angle X$$

and

$$\angle G \cong \angle Y$$

? What conclusion could you draw about $\angle H$ and $\angle Z$? After completing this Concept, you'll be able to make such a conclusion.

Watch This



MEDIA

Click image to the left for more content.

CK-12 The Third Angle Theorem

Guidance

If two angles in one triangle are congruent to two angles in another triangle, then the third pair of angles must also be congruent. This is called the **Third Angle Theorem**.

If $\angle A \cong \angle D$ and $\angle B \cong \angle E$, then $\angle C \cong \angle F$.

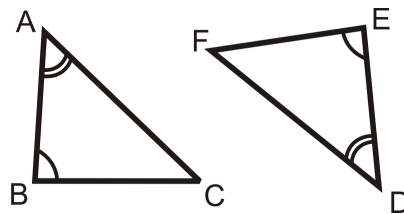

Example A

Determine the measure of the missing angles.

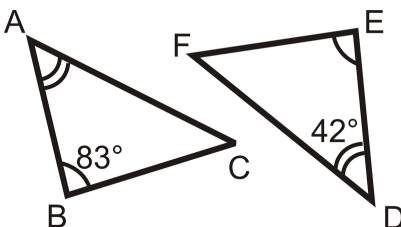

From the Third Angle Theorem, we know $\angle C \cong \angle F$. From the Triangle Sum Theorem, we know that the sum of the interior angles in each triangle is 180° .

$$m\angle A + m\angle B + m\angle C = 180^\circ$$

$$m\angle D + m\angle E + m\angle F = 180^\circ$$

$$42^\circ + 83^\circ + m\angle C = 180^\circ$$

$$m\angle C = 55^\circ = m\angle F$$

Example B

Explain why the Third Angle Theorem works.

The Third Angle Theorem is really like an extension of the Triangle Sum Theorem. Once you know two angles in a triangle, you automatically know the third because of the Triangle Sum Theorem. This means that if you have two triangles with two pairs of angles congruent between them, when you use the Triangle Sum Theorem on each triangle to come up with the third angle you will get the same answer both times. Therefore, the third pair of angles must also be congruent.

Example C

Determine the measure of all the angles in the triangle:

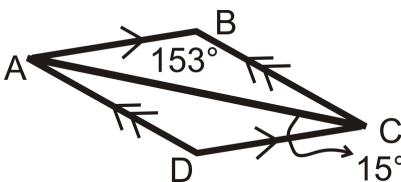

First we can see that $m\angle DCA = 15^\circ$. This means that $m\angle BAC = 15^\circ$ also because they are alternate interior angles. $m\angle ABC = 153^\circ$ was given. This means by the Triangle Sum Theorem that $m\angle BCA = 12^\circ$. This means that $m\angle CAD = 12^\circ$ also because they are alternate interior angles. Finally, $m\angle ADC = 153^\circ$ by the Triangle Sum Theorem.



MEDIA

Click image to the left for more content.

Guided Practice

Determine the measure of all the angles in the each triangle.

1.

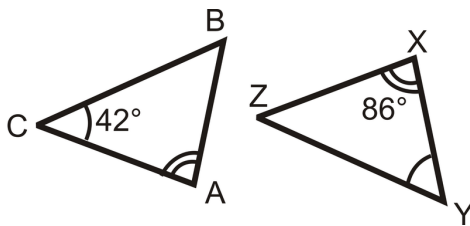

2.

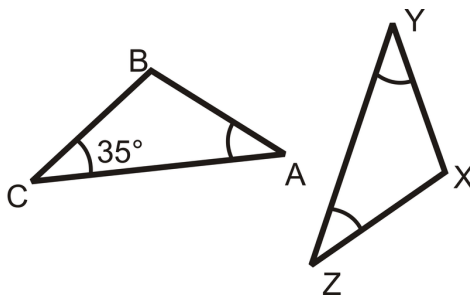

3.

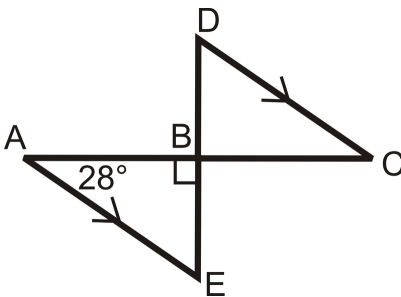

Answers:

1. $m\angle A = 86$, $m\angle C = 42$ and by the Triangle Sum Theorem $m\angle B = 52$.
 $m\angle Y = 42$, $m\angle X = 86$ and by the Triangle Sum Theorem, $m\angle Z = 52$.
2. $m\angle C = m\angle A = m\angle Y = m\angle Z = 35$. By the Triangle Sum Theorem $m\angle B = m\angle X = 110$.
3. $m\angle A = 28$, $m\angle ABE = 90$ and by the Triangle Sum Theorem, $m\angle E = 62$. $m\angle D = m\angle E = 62$ because they are alternate interior angles and the lines are parallel. $m\angle C = m\angle A = 28$ because they are alternate interior angles and the lines are parallel. $m\angle DBC = m\angle ABE = 90$ because they are vertical angles.

Practice

Determine the measures of the unknown angles.

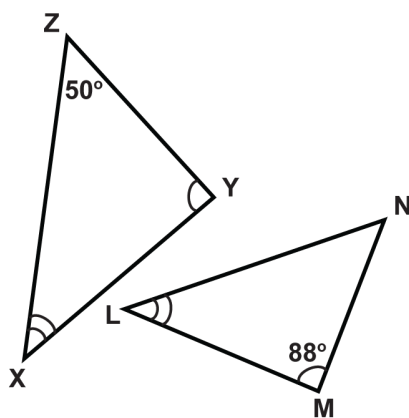

1. $\angle XYZ$
2. $\angle ZXY$
3. $\angle LNM$
4. $\angle MLN$

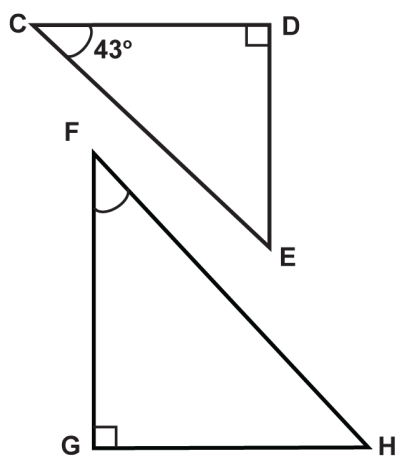

5. $\angle CED$
6. $\angle GFH$
7. $\angle FHG$

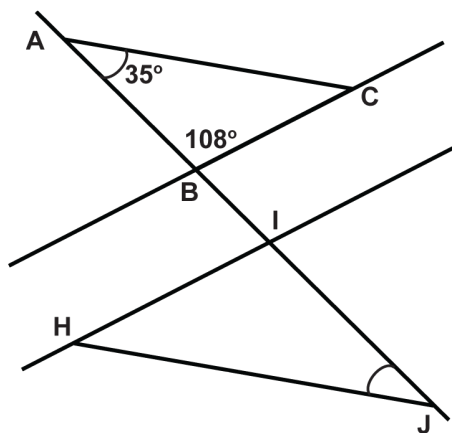

8. $\angle ACB$
9. $\angle HIJ$
10. $\angle HJI$
11. $\angle IHJ$

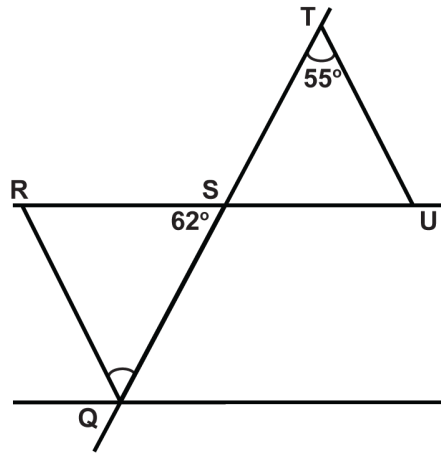

12. $\angle RQS$
13. $\angle SRQ$
14. $\angle TSU$
15. $\angle TUS$

4.6 SSS Triangle Congruence

Here you'll learn how to prove that triangles are congruent given information only about their sides.

What if you were given two triangles and provided with information only about their side lengths? How could you determine if the two triangles were congruent? After completing this concept, you'll be able to use the Side-Side-Side (SSS) shortcut to prove triangle congruency.

Watch This



MEDIA

Click image to the left for more content.

CK-12

Watch the portions of the following two videos that deal with SSS triangle congruence.

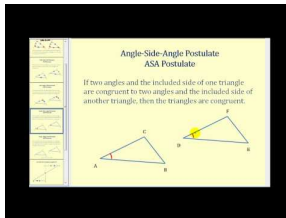

MEDIA

Click image to the left for more content.

James Sousa: Introduction to Congruent Triangles

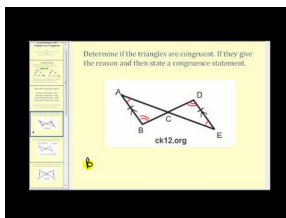

MEDIA

Click image to the left for more content.

James Sousa: Determining If Two Triangles are Congruent

Guidance

If 3 sides in one triangle are congruent to 3 sides in another triangle, then the triangles are congruent.

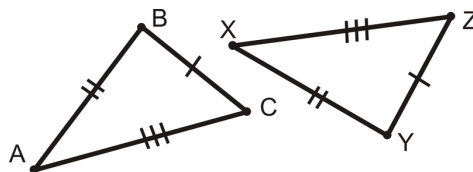

$\overline{BC} \cong \overline{YZ}$, $\overline{AB} \cong \overline{XY}$, and $\overline{AC} \cong \overline{XZ}$ then $\triangle ABC \cong \triangle XYZ$.

This is called the Side-Side-Side (SSS) Postulate and it is a shortcut for proving that two triangles are congruent. Before, you had to show **3 sides and 3 angles** in one triangle were congruent to **3 sides and 3 angles** in another triangle. Now you only have to show **3 sides** in one triangle are congruent to **3 sides** in another.

Example A

Write a triangle congruence statement based on the picture below:

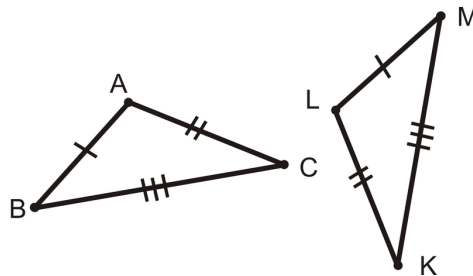

From the tic marks, we know $\overline{AB} \cong \overline{LM}$, $\overline{AC} \cong \overline{LK}$, $\overline{BC} \cong \overline{MK}$. From the SSS Postulate, the triangles are congruent. Lining up the corresponding sides, we have $\triangle ABC \cong \triangle LMK$.

Don't forget ORDER MATTERS when writing congruence statements. Line up the sides with the same number of tic marks.

Example B

Write a two-column proof to show that the two triangles are congruent.

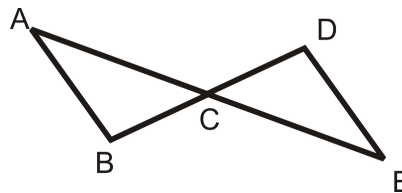

Given: $\overline{AB} \cong \overline{DE}$

C is the midpoint of \overline{AE} and \overline{DB} .

Prove: $\triangle ACB \cong \triangle ECD$

TABLE 4.2:

<i>Statement</i>	<i>Reason</i>
1. $\overline{AB} \cong \overline{DE}$	1. Given
C is the midpoint of \overline{AE} and \overline{DB}	
2. $\overline{AC} \cong \overline{CE}$, $\overline{BC} \cong \overline{CD}$	2. Definition of a midpoint
3. $\triangle ACB \cong \triangle ECD$	3. SSS Postulate

Note that you must *clearly state* the three sets of sides are congruent BEFORE stating the triangles are congruent.

Example C

The only way we will show two triangles are congruent in an $x - y$ plane is using SSS.

Find the lengths of all the line segments from both triangles to see if the two triangles are congruent.

To do this, you need to use the distance formula.

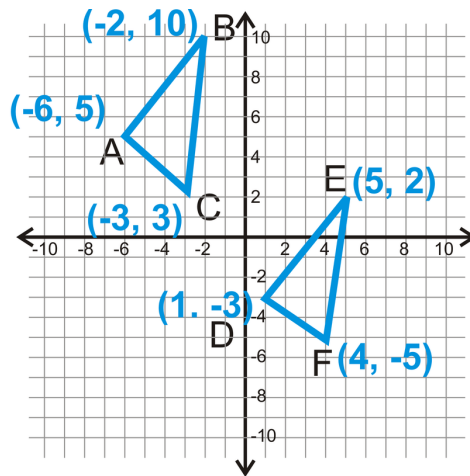

Begin with $\triangle ABC$ and its sides.

$$\begin{aligned} AB &= \sqrt{(-6 - (-2))^2 + (5 - 10)^2} \\ &= \sqrt{(-4)^2 + (-5)^2} \\ &= \sqrt{16 + 25} \\ &= \sqrt{41} \end{aligned}$$

$$\begin{aligned} BC &= \sqrt{(-2 - (-3))^2 + (10 - 3)^2} \\ &= \sqrt{(1)^2 + (7)^2} \\ &= \sqrt{1 + 49} \\ &= \sqrt{50} = 5\sqrt{2} \end{aligned}$$

$$\begin{aligned} AC &= \sqrt{(-6 - (-3))^2 + (5 - 3)^2} \\ &= \sqrt{(-3)^2 + (2)^2} \\ &= \sqrt{9 + 4} \\ &= \sqrt{13} \end{aligned}$$

Now, find the lengths of all the sides in $\triangle DEF$.

$$\begin{aligned}
 DE &= \sqrt{(1-5)^2 + (-3-2)^2} \\
 &= \sqrt{(-4)^2 + (-5)^2} \\
 &= \sqrt{16+25} \\
 &= \sqrt{41}
 \end{aligned}$$

$$\begin{aligned}
 EF &= \sqrt{(5-4)^2 + (2-(-5))^2} \\
 &= \sqrt{(1)^2 + (7)^2} \\
 &= \sqrt{1+49} \\
 &= \sqrt{50} = 5\sqrt{2}
 \end{aligned}$$

$$\begin{aligned}
 DF &= \sqrt{(1-4)^2 + (-3-(-5))^2} \\
 &= \sqrt{(-3)^2 + (2)^2} \\
 &= \sqrt{9+4} \\
 &= \sqrt{13}
 \end{aligned}$$

$AB = DE$, $BC = EF$, and $AC = DF$, so the two triangles are congruent by SSS.



MEDIA

Click image to the left for more content.

CK-12

Guided Practice

1. Determine if the two triangles are congruent.

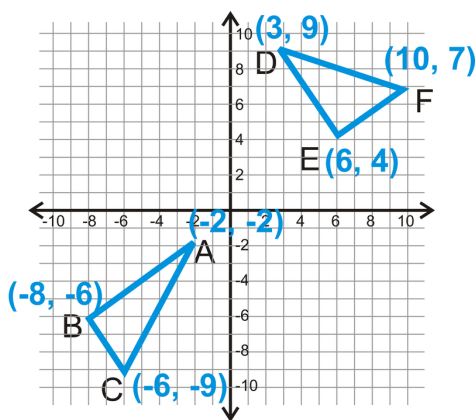

2. Fill in the blanks in the proof below.

Given: $\overline{AB} \cong \overline{DC}$, $\overline{AC} \cong \overline{DB}$

Prove: $\triangle ABC \cong \triangle DCB$

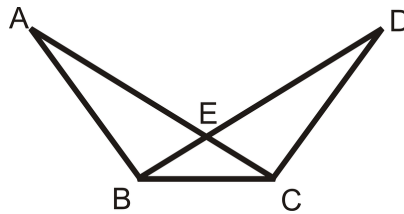
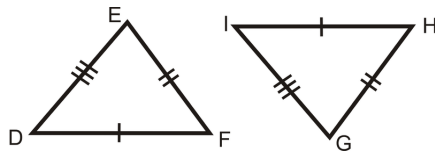

TABLE 4.3:

<i>Statement</i>	<i>Reason</i>
1.	1.
2.	2. Reflexive PoC
3. $\triangle ABC \cong \triangle DCB$	3.

3. Is the pair of triangles congruent? If so, write the congruence statement and why.



Answers:

1. Start with $\triangle ABC$.

$$\begin{aligned}
 AB &= \sqrt{(-2 - (-8))^2 + (-2 - (-6))^2} \\
 &= \sqrt{(6)^2 + (4)^2} \\
 &= \sqrt{36 + 16} \\
 &= \sqrt{52} = 2\sqrt{13}
 \end{aligned}$$

$$\begin{aligned}
 BC &= \sqrt{(-8 - (-6))^2 + (-6 - (-9))^2} \\
 &= \sqrt{(-2)^2 + (3)^2} \\
 &= \sqrt{4 + 9} \\
 &= \sqrt{13}
 \end{aligned}$$

$$\begin{aligned}
 AC &= \sqrt{(-2 - (-6))^2 + (-2 - (-9))^2} \\
 &= \sqrt{(4)^2 + (7)^2} \\
 &= \sqrt{16 + 49} \\
 &= \sqrt{65}
 \end{aligned}$$

Now find the sides of $\triangle DEF$.

$$\begin{aligned}
 DE &= \sqrt{(3 - 6)^2 + (9 - 4)^2} \\
 &= \sqrt{(-3)^2 + (5)^2} \\
 &= \sqrt{9 + 25} \\
 &= \sqrt{34}
 \end{aligned}$$

$$\begin{aligned}
 EF &= \sqrt{(6 - 10)^2 + (4 - 7)^2} \\
 &= \sqrt{(-4)^2 + (-3)^2} \\
 &= \sqrt{16 + 9} \\
 &= \sqrt{25} = 5
 \end{aligned}$$

$$\begin{aligned}
 DF &= \sqrt{(3 - 10)^2 + (9 - 7)^2} \\
 &= \sqrt{(-7)^2 + (2)^2} \\
 &= \sqrt{49 + 4} \\
 &= \sqrt{53}
 \end{aligned}$$

No sides have equal measures, so the triangles are not congruent.

2.

TABLE 4.4:

<i>Statement</i>	<i>Reason</i>
1. $\overline{AB} \cong \overline{DC}$, $\overline{AC} \cong \overline{DB}$	1. Given
2. $\overline{BC} \cong \overline{CB}$	2. Reflexive PoC
3. $\triangle ABC \cong \triangle DCB$	3. SSS Postulate

3. The triangles are congruent because they have three pairs of sides congruent. $\triangle DEF \cong \triangle IGH$.

Practice

Are the pairs of triangles congruent? If so, write the congruence statement and why.

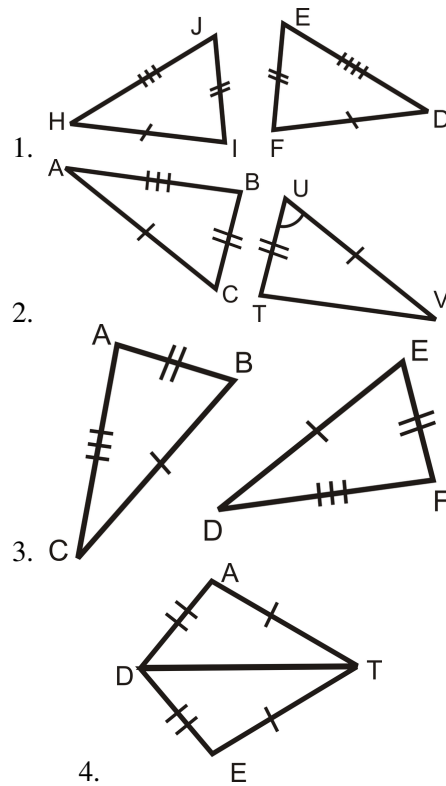

State the additional piece of information needed to show that each pair of triangles is congruent.

5. Use SSS

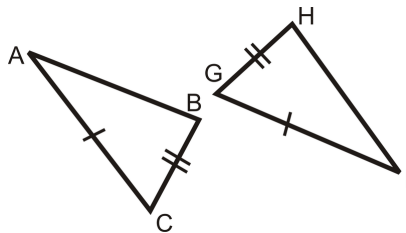

6. Use SSS

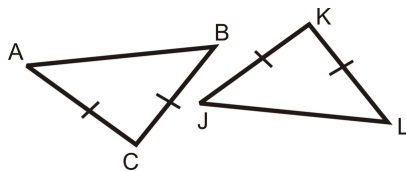

Fill in the blanks in the proofs below.

7. Given: B is the midpoint of \overline{DC} Prove: $\triangle ABD \cong \triangle ABC$

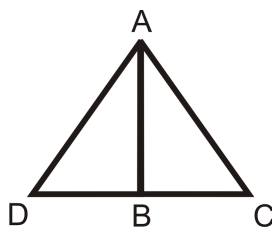
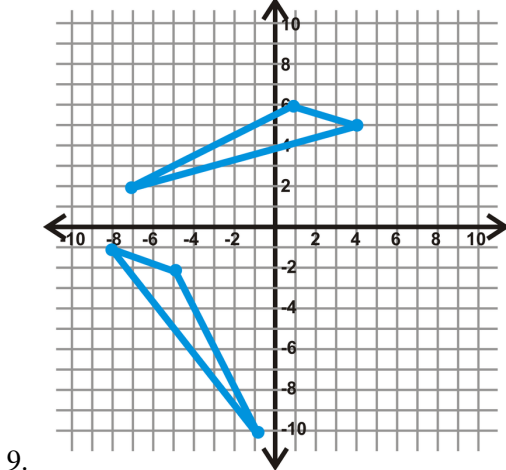
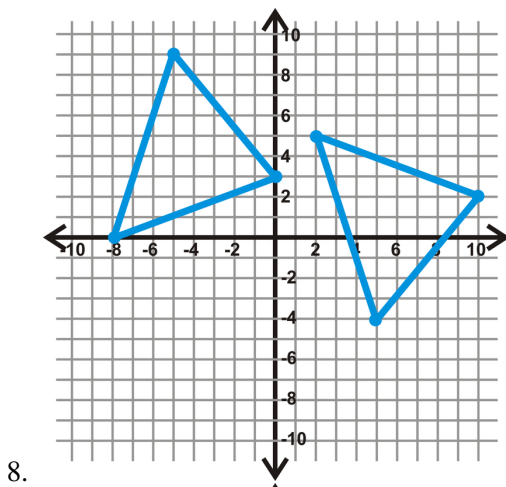

TABLE 4.5:

<i>Statement</i>	<i>Reason</i>
1.	1.
2.	2. Definition of a Midpoint
3.	3. Reflexive PoC
4. $\triangle ABD \cong \triangle ABC$	4.

Find the lengths of the sides of each triangle to see if the two triangles are congruent. Leave your answers under the radical.



10. $\triangle ABC : A(-1,5), B(-4,2), C(2,-2)$ and $\triangle DEF : D(7,-5), E(4,2), F(8,-9)$

11. $\triangle ABC : A(-8,-3), B(-2,-4), C(-5,-9)$ and $\triangle DEF : D(-7,2), E(-1,3), F(-4,8)$

4.7 SAS Triangle Congruence

Here you'll learn how to prove that triangles are congruent given information only about two of their sides and the angle between those two sides.

What if you were given two triangles and provided with only two of their side lengths and the measure of the angle between those two sides? How could you determine if the two triangles were congruent? After completing this Concept, you'll be able to use the Side-Angle-Side (SAS) shortcut to prove triangle congruency.

Watch This



MEDIA

Click image to the left for more content.

CK-12

Watch the portions of the following two videos that deal with SAS triangle congruence.

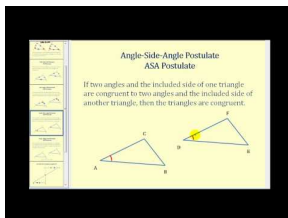

MEDIA

Click image to the left for more content.

James Sousa: Introduction to Congruent Triangles

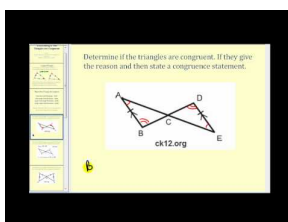

MEDIA

Click image to the left for more content.

James Sousa: Determining If Two Triangles are Congruent

Finally, watch this video.

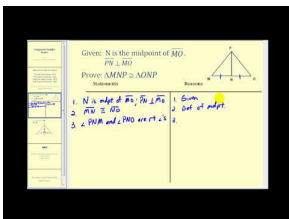

MEDIA
 Click image to the left for more content.

James Sousa:Example1: Prove Two Triangles are Congruent

Guidance

If two sides and the included angle in one triangle are congruent to two sides and the included angle in another triangle, then the two triangles are congruent. (When an angle is between two given sides of a polygon it is called an **included angle**.)

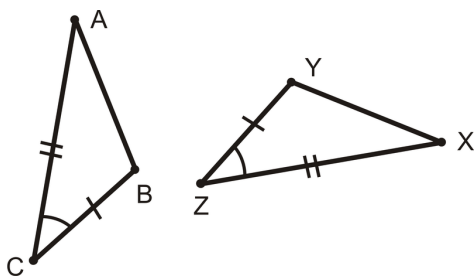

$\overline{AC} \cong \overline{XZ}$, $\overline{BC} \cong \overline{YZ}$, and $\angle C \cong \angle Z$, then $\triangle ABC \cong \triangle XYZ$.

This is called the Side-Angle-Side (SAS) Postulate and it is a shortcut for proving that two triangles are congruent. The placement of the word Angle is important because it indicates that the angle you are given is *between* the two sides.

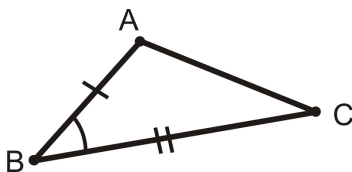

$\angle B$ would be the included angle for sides \overline{AB} and \overline{BC} .

Example A

What additional piece of information do you need to show that these two triangles are congruent using the SAS Postulate?

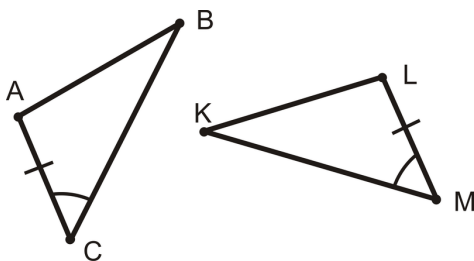

- a) $\angle ABC \cong \angle LKM$
 b) $\overline{AB} \cong \overline{LK}$
 c) $\overline{BC} \cong \overline{KM}$
 d) $\angle BAC \cong \angle KLM$

For the SAS Postulate, you need the side on the other side of the angle. In $\triangle ABC$, that is \overline{BC} and in $\triangle LKM$ that is \overline{KM} . The answer is c.

Example B

Write a two-column proof to show that the two triangles are congruent.

Given: C is the midpoint of \overline{AE} and \overline{DB}

Prove: $\triangle ACB \cong \triangle ECD$

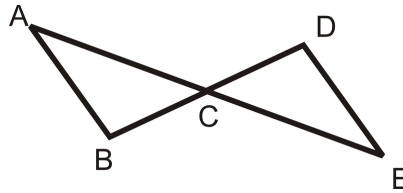

TABLE 4.6:

Statement

1. C is the midpoint of \overline{AE} and \overline{DB}
2. $\overline{AC} \cong \overline{CE}$, $\overline{BC} \cong \overline{CD}$
3. $\angle ACB \cong \angle DCE$
4. $\triangle ACB \cong \triangle ECD$

Reason

1. Given
2. Definition of a midpoint
3. Vertical Angles Postulate
4. SAS Postulate

Example C

Is the pair of triangles congruent? If so, write the congruence statement and why.

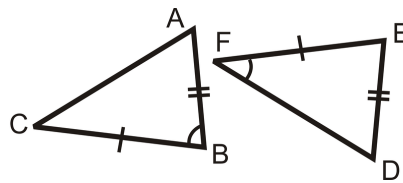

While the triangles have two pairs of sides and one pair of angles that are congruent, the angle is not in the same place in both triangles. The first triangle fits with SAS, but the second triangle is SSA. There is not enough information for us to know whether or not these triangles are congruent.



MEDIA

Click image to the left for more content.

CK-12

Guided Practice

1. Is the pair of triangles congruent? If so, write the congruence statement and why.

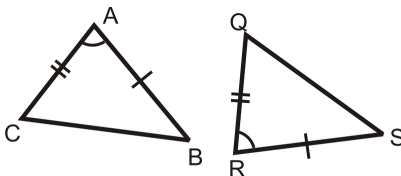

2. State the additional piece of information needed to show that each pair of triangles is congruent.

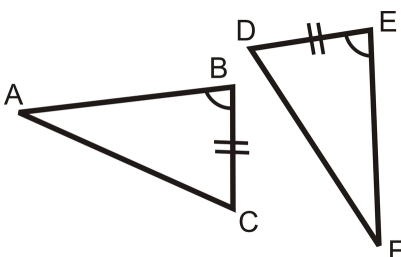

3. Fill in the blanks in the proof below.

Given:

$$\overline{AB} \cong \overline{DC}, \overline{BE} \cong \overline{CE}$$

Prove: $\triangle ABE \cong \triangle ACE$

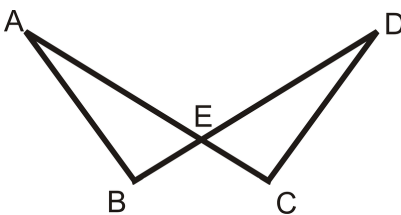

TABLE 4.7:

<i>Statement</i>	<i>Reason</i>
1.	1.
2. $\angle AEB \cong \angle DEC$	2.
3. $\triangle ABE \cong \triangle ACE$	3.

Answers:

- The pair of triangles is congruent by the SAS postulate. $\triangle CAB \cong \triangle QRS$.
- We know that one pair of sides and one pair of angles are congruent from the diagram. In order to know that the triangles are congruent by SAS we need to know that the pair of sides on the other side of the angle are congruent. So, we need to know that $\overline{EF} \cong \overline{BA}$.

3.

TABLE 4.8:

<i>Statement</i>	<i>Reason</i>
1. $\overline{AB} \cong \overline{DC}$, $\overline{BE} \cong \overline{CE}$	1. Given
2. $\angle AEB \cong \angle DEC$	2. Vertical Angle Theorem
3. $\triangle ABE \cong \triangle ACE$	3. SAS postulate

Practice

Are the pairs of triangles congruent? If so, write the congruence statement and why.

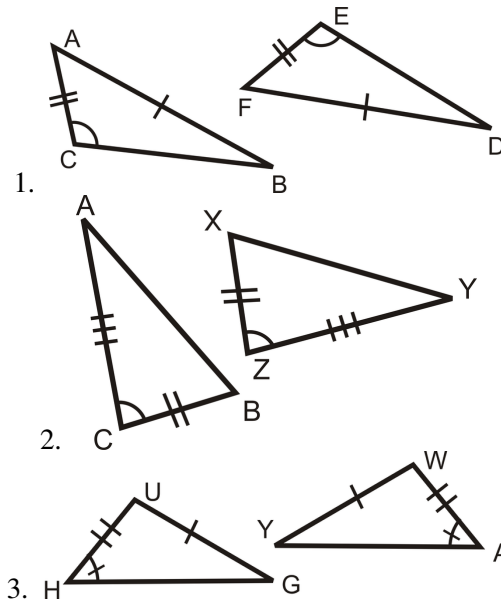

State the additional piece of information needed to show that each pair of triangles is congruent.

4. Use SAS

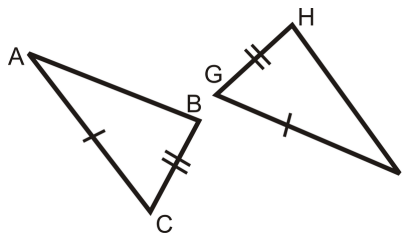

5. Use SAS

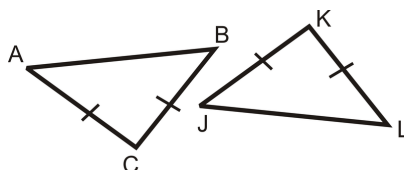

6. Use SAS

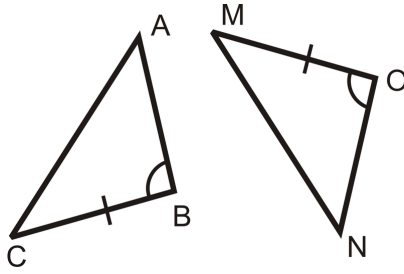

Fill in the blanks in the proofs below.

7. Given: B is a midpoint of \overline{DC} , $\overline{AB} \perp \overline{DC}$ Prove: $\triangle ABD \cong \triangle ABC$

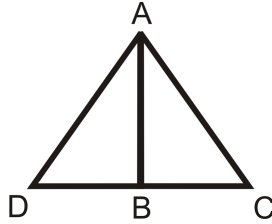

TABLE 4.9:

Statement	Reason
1. B is a midpoint of \overline{DC} , $\overline{AB} \perp \overline{DC}$	1.
2.	2. Definition of a midpoint
3. $\angle ABD$ and $\angle ABC$ are right angles	3.
4.	4. All right angles are \cong
5.	5.
6. $\triangle ABD \cong \triangle ABC$	6.

8. Given: \overline{AB} is an angle bisector of $\angle DAC$, $\overline{AD} \cong \overline{AC}$ Prove: $\triangle ABD \cong \triangle ABC$

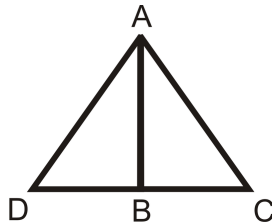

TABLE 4.10:

Statement	Reason
1.	1.
2. $\angle DAB \cong \angle BAC$	2.
3.	3. Reflexive PoC
4. $\triangle ABD \cong \triangle ABC$	4.

9. Given: B is the midpoint of \overline{DE} and $\overline{AC} \perp \overline{ABE}$ is a right angle Prove: $\triangle ABE \cong \triangle CBD$

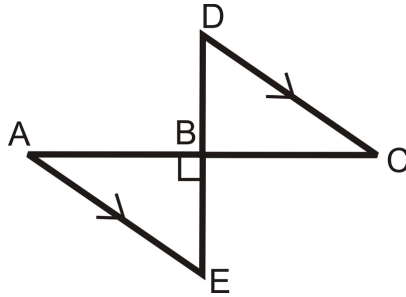

TABLE 4.11:

<i>Statement</i>	<i>Reason</i>
1.	1. Given
2. $\overline{DB} \cong \overline{BE}$, $\overline{AB} \cong \overline{BC}$	2.
3.	3. Definition of a Right Angle
4.	4. Vertical Angle Theorem
5. $\triangle ABE \cong \triangle CBD$	5.

10. Given: \overline{DB} is the angle bisector of $\angle ADC$ $\overline{AD} \cong \overline{DC}$ Prove: $\triangle ABD \cong \triangle CBD$

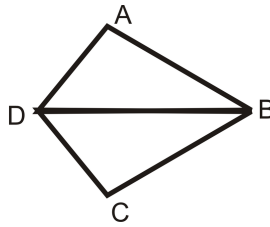

TABLE 4.12:

<i>Statement</i>	<i>Reason</i>
1.	1.
2. $\angle ADB \cong \angle BDC$	2.
3.	3.
4. $\triangle ABD \cong \triangle CBD$	4.

4.8 ASA and AAS Triangle Congruence

Here you'll learn how to prove that triangles are congruent given information only about two of their angles and one of their sides.

What if you were given two triangles and provided with only the measure of two of their angles and one of their side lengths? How could you determine if the two triangles were congruent? After completing this Concept, you'll be able to use the Angle-Side-Angle (ASA) and Angle-Angle-Side (AAS) shortcuts to prove triangle congruency.

Watch This



MEDIA

Click image to the left for more content.

CK-12 ASA and AAS Triangle Congruence

Watch the portions of the following two videos that deal with ASA and AAS triangle congruence.

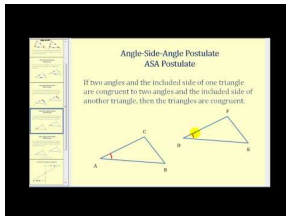

MEDIA

Click image to the left for more content.

James Sousa: Introduction to Congruent Triangles

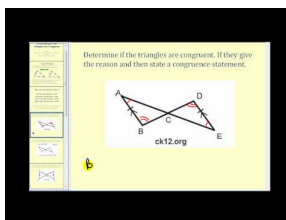

MEDIA

Click image to the left for more content.

James Sousa: Determining If Two Triangles are Congruent

Finally, watch this video.

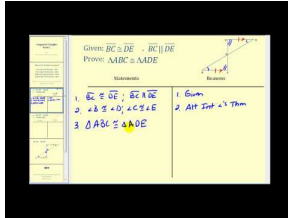

MEDIA

Click image to the left for more content.

James Sousa:Example2: Prove Two Triangles are Congruent

Guidance

If two angles and one side in one triangle are congruent to the corresponding two angles and one side in another triangle, then the two triangles are congruent. This idea encompasses two triangle congruence shortcuts: Angle-Side-Angle and Angle-Angle-Side.

Angle-Side-Angle (ASA) Congruence Postulate: If two angles and the included side in one triangle are congruent to two angles and the included side in another triangle, then the two triangles are congruent.

Angle-Angle-Side (AAS) Congruence Theorem: If two angles and a non-included side in one triangle are congruent to two angles and the corresponding non-included side in another triangle, then the triangles are congruent.

The placement of the word Side is important because it indicates where the side that you are given is in relation to the angles. The pictures below help to show the difference between the two shortcuts.

ASA

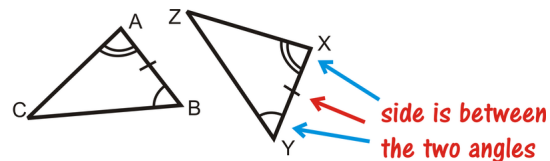

AAS

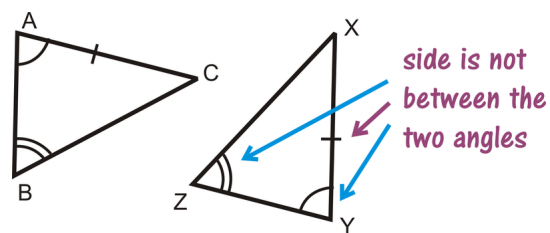

Example A

What information do you need to prove that these two triangles are congruent using the ASA Postulate?

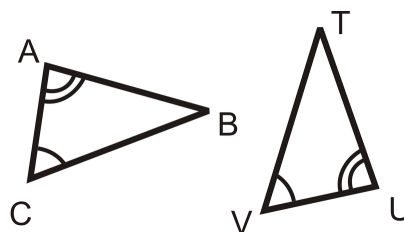

a) $\overline{AB} \cong \overline{UT}$

b) $\overline{AC} \cong \overline{UV}$

c) $\overline{BC} \cong \overline{TV}$

d) $\angle B \cong \angle T$

For ASA, we need the side between the two given angles, which is \overline{AC} and \overline{UV} . The answer is b.

Example B

Write a 2-column proof.

Given: $\angle C \cong \angle E$, $\overline{AC} \cong \overline{AE}$

Prove: $\triangle ACF \cong \triangle AEB$

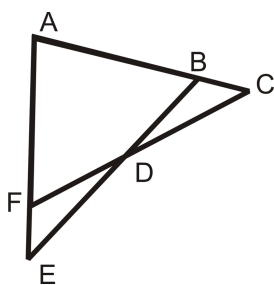
**TABLE 4.13:****Statement**

1. $\angle C \cong \angle E$, $\overline{AC} \cong \overline{AE}$
2. $\angle A \cong \angle A$
3. $\triangle ACF \cong \triangle AEB$

Reason

1. Given
2. Reflexive PoC
3. ASA

Example C

What information do you need to prove that these two triangles are congruent using:

- a) ASA?
- b) AAS?

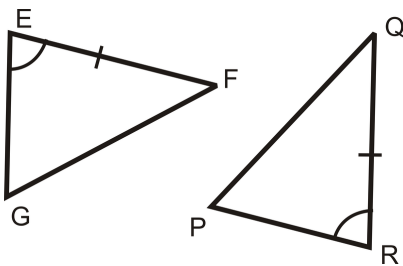
**Solution:**

- a) For ASA, we need the angles on the other side of \overline{EF} and \overline{QR} . $\angle F \cong \angle Q$
- b) For AAS, we would need the other angle. $\angle G \cong \angle P$



MEDIA

Click image to the left for more content.

CK-12 ASA and AAS Triangle Congruence

Guided Practice

1. Can you prove that the following triangles are congruent? Why or why not?

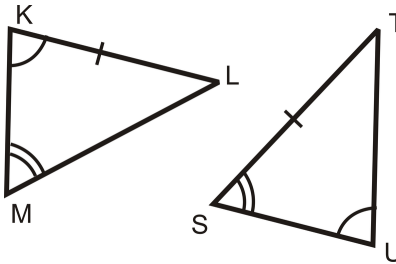

2. Write a 2-column proof.

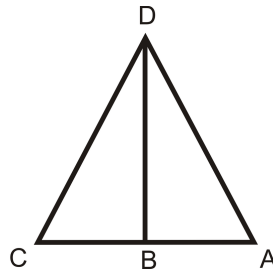

Given: \overline{BD} is an angle bisector of $\angle CDA$, $\angle C \cong \angle A$

Prove: $\triangle CBD \cong \triangle ABD$

3. Write a 2-column proof.

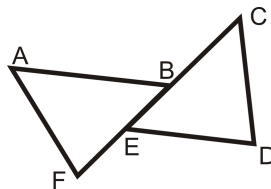

Given: $\overline{AB} \parallel \overline{ED}$, $\angle C \cong \angle F$, $\overline{AB} \cong \overline{ED}$

Prove: $\overline{AF} \cong \overline{CD}$

Answers:

1. We cannot show the triangles are congruent because \overline{KL} and \overline{ST} are *not corresponding*, even though they are congruent. To determine if \overline{KL} and \overline{ST} are corresponding, look at the angles around them, $\angle K$ and $\angle L$ and $\angle S$ and $\angle T$. $\angle K$ has **one** arc and $\angle L$ is unmarked. $\angle S$ has **two** arcs and $\angle T$ is unmarked. In order to use AAS, $\angle S$ needs to be congruent to $\angle K$.

2.

TABLE 4.14:

<i>Statement</i>	<i>Reason</i>
1. \overline{BD} is an angle bisector of $\angle CDA$, $\angle C \cong \angle A$	1. Given
2. $\angle CDB \cong \angle ADB$	2. Definition of an Angle Bisector
3. $\overline{DB} \cong \overline{DB}$	3. Reflexive PoC
4. $\triangle CBD \cong \triangle ABD$	4. AAS

3.

TABLE 4.15:

<i>Statement</i>	<i>Reason</i>
1. $\overline{AB} \parallel \overline{ED}$, $\angle C \cong \angle F$, $\overline{AB} \cong \overline{ED}$	1. Given
2. $\angle ABE \cong \angle DEB$	2. Alternate Interior Angles Theorem
3. $\triangle ABF \cong \triangle DEC$	3. ASA
4. $\overline{AF} \cong \overline{CD}$	4. CPCTC (Corresponding Parts of Congruent Triangles are Congruent)

Practice

For questions 1-3, determine if the triangles are congruent. If they are, write the congruence statement and which congruence postulate or theorem you used.

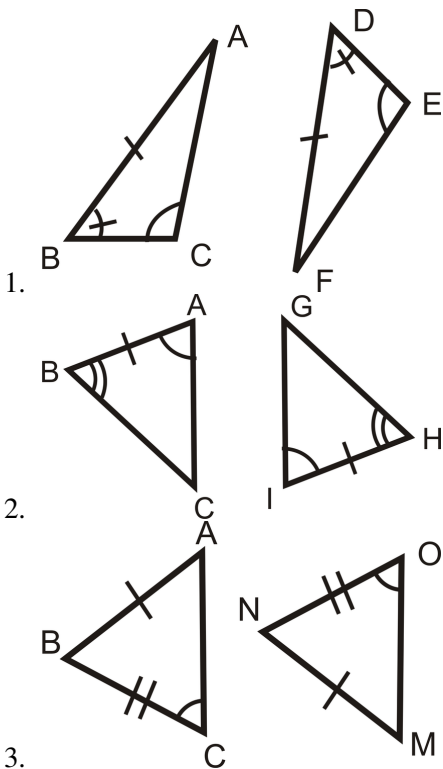

For questions 4-8, use the picture and the given information below.

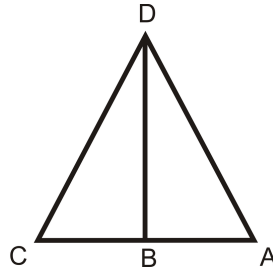

Given: $\overline{DB} \perp \overline{AC}$, \overline{DB} is the angle bisector of $\angle CDA$

4. From $\overline{DB} \perp \overline{AC}$, which angles are congruent and why?
5. Because \overline{DB} is the angle bisector of $\angle CDA$, what two angles are congruent?
6. From looking at the picture, what additional piece of information are you given? Is this enough to prove the two triangles are congruent?
7. Write a 2-column proof to prove $\triangle CDB \cong \triangle ADB$, using #4-6.
8. What would be your reason for $\angle C \cong \angle A$?

For questions 9-13, use the picture and the given information.

Given: $\overline{LP} \parallel \overline{NO}$, $\overline{LP} \cong \overline{NO}$

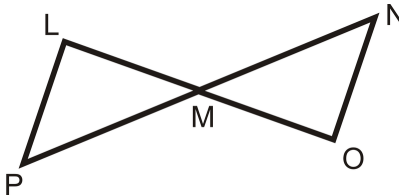

9. From $\overline{LP} \parallel \overline{NO}$, which angles are congruent and why?
10. From looking at the picture, what additional piece of information can you conclude?
11. Write a 2-column proof to prove $\triangle LMP \cong \triangle OMN$.
12. What would be your reason for $\overline{LM} \cong \overline{MO}$?
13. Fill in the blanks for the proof below. Use the given from above. Prove: M is the midpoint of \overline{PN} .

TABLE 4.16:

Statement

1. $\overline{LP} \parallel \overline{NO}$, $\overline{LP} \cong \overline{NO}$

2.

3.

4. $\overline{LM} \cong \overline{MO}$

5. M is the midpoint of \overline{PN} .

Reason

1. Given

2. Alternate Interior Angles

3. ASA

4.

5.

Determine the additional piece of information needed to show the two triangles are congruent by the given postulate.

14. AAS

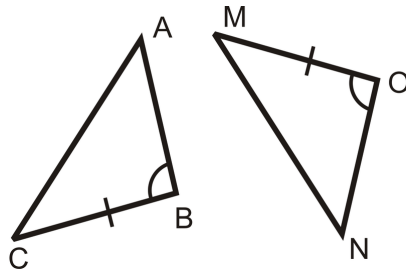

15. ASA

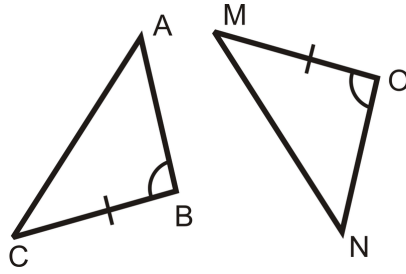

16. ASA

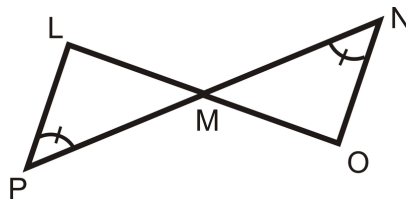

17. AAS

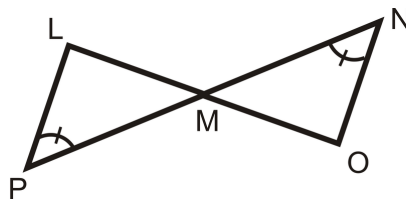

4.9 HL Triangle Congruence

Here you'll learn how to prove that right triangles are congruent given the length of only their hypotenuses and one of their legs.

What if you were given two right triangles and provided with only the measure of their hypotenuses and one of their legs? How could you determine if the two right triangles were congruent? After completing this Concept, you'll be able to use the Hypotenuse-Leg (HL) shortcut to prove right triangle congruency.

Watch This



MEDIA

Click image to the left for more content.

CK-12 HL Triangle Congruence

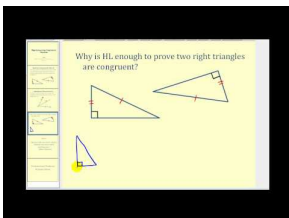

MEDIA

Click image to the left for more content.

James Sousa: Hypotenuse-Leg Congruence Theorem

Guidance

If the hypotenuse and leg in one **right** triangle are congruent to the hypotenuse and leg in another **right** triangle, then the two triangles are congruent. This is called the **Hypotenuse-Leg (HL) Congruence Theorem**. Note that it will only work for **right** triangles.

If $\triangle ABC$ and $\triangle XYZ$ are both right triangles and $\overline{AB} \cong \overline{XY}$ and $\overline{BC} \cong \overline{YZ}$ then $\triangle ABC \cong \triangle XYZ$.

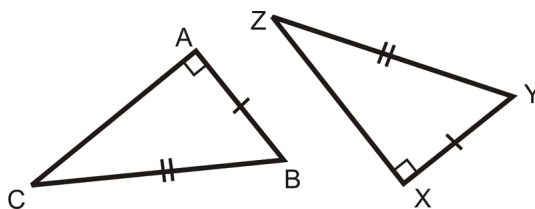

Example A

What additional information would you need to prove that these two triangles were congruent using the HL Theorem?

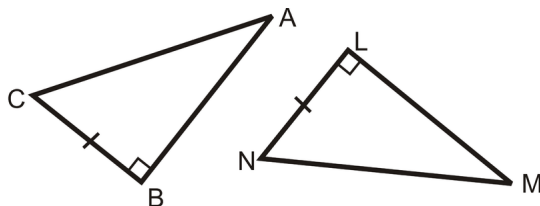

For HL, you need the hypotenuses to be congruent. $\overline{AC} \cong \overline{MN}$.

Example B

Determine if the triangles are congruent. If they are, write the congruence statement and which congruence postulate or theorem you used.

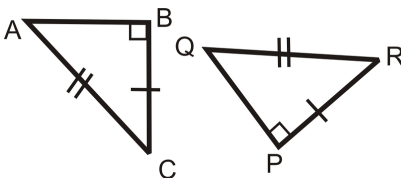

We know the two triangles are right triangles. They have one pair of legs that is congruent and their hypotenuses are congruent. This means that $\triangle ABC \cong \triangle RQP$ by HL.

Example C

Determine the additional piece of information needed to show the two triangles are congruent by HL.

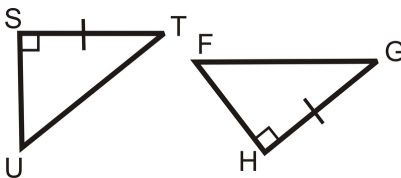

We already know one pair of legs is congruent and that they are right triangles. The additional piece of information we need is that the two hypotenuses are congruent, $\overline{UT} \cong \overline{FG}$.



MEDIA

Click image to the left for more content.

[CK-12 HL Triangle Congruence](#)

Guided Practice

1. Determine if the triangles are congruent. If they are, write the congruence statement and which congruence postulate or theorem you used.

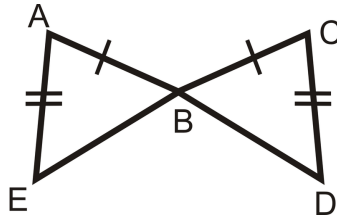

2. Fill in the blanks in the proof below.

Given:

$$\overline{SV} \perp \overline{WU}$$

T is the midpoint of \overline{SV} and \overline{WU}

Prove: $\overline{WS} \cong \overline{UV}$

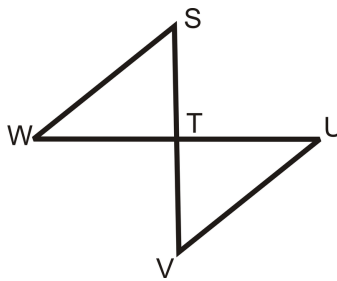

TABLE 4.17:

<i>Statement</i>	<i>Reason</i>
1.	1.
2. $\angle STW$ and $\angle UTV$ are right angles	2.
3.	3.
4. $\overline{ST} \cong \overline{TV}$, $\overline{WT} \cong \overline{TU}$	4.
5. $\triangle STW \cong \triangle UTV$	5.
6. $\overline{WS} \cong \overline{UV}$	6.

3. Explain why the HL Congruence shortcut works.

Answers:

1. All we know is that two pairs of sides are congruent. Since we do not know if these are right triangles, we cannot use HL. We do not know if these triangles are congruent.

2.

TABLE 4.18:

<i>Statement</i>	<i>Reason</i>
1. $\overline{SV} \perp \overline{WU}$	1. Given
2. $\angle STW$ and $\angle UTV$ are right angles	2. Definition of perpendicular lines.
3. T is the midpoint of \overline{SV} and \overline{WU}	3. Given
4. $\overline{ST} \cong \overline{TV}$, $\overline{WT} \cong \overline{TU}$	4. Definition of midpoint
5. $\triangle STW \cong \triangle UTV$	5. SAS
6. $\overline{WS} \cong \overline{UV}$	6. CPCTC

Note that even though these were right triangles, we did not use the HL congruence shortcut because we were not originally given that the two hypotenuses were congruent. The SAS congruence shortcut was quicker in this case.

3. The Pythagorean Theorem, which says, for any **right** triangle, this equation is true:

$$(\text{leg})^2 + (\text{leg})^2 = (\text{hypotenuse})^2$$

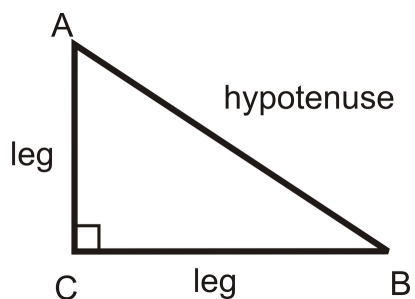

What this means is that if you are given two sides of a right triangle, you can always find the third. Therefore, if you know two sides of a right triangle are congruent to two sides of another right triangle, then you can conclude that the third sides are also congruent. If three pairs of sides are congruent, then we know the triangles are congruent by SSS.

Practice

Using the HL Theorem, what information do you need to prove the two triangles are congruent?

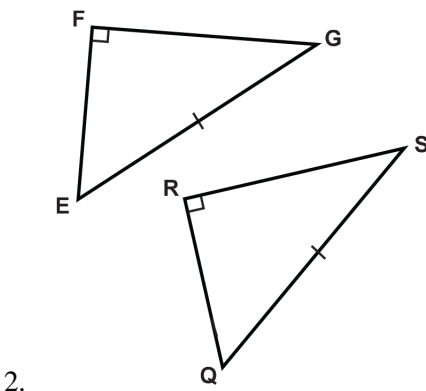
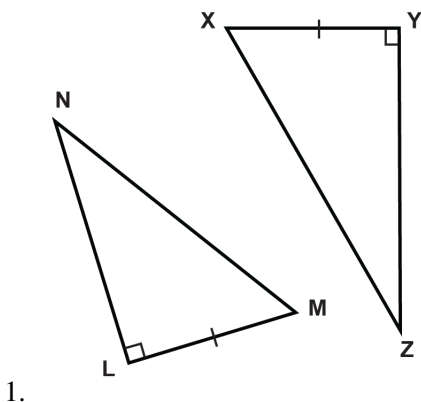

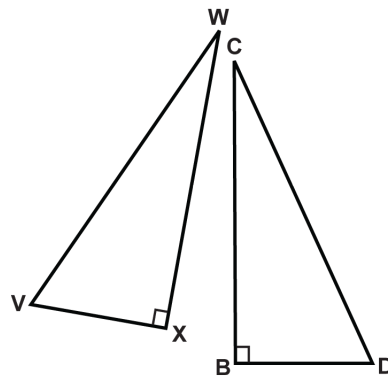

3.

The triangles are formed by two parallel lines cut by a perpendicular transversal. C is the midpoint of \overline{AD} . Complete the proof to show the two triangles are congruent.

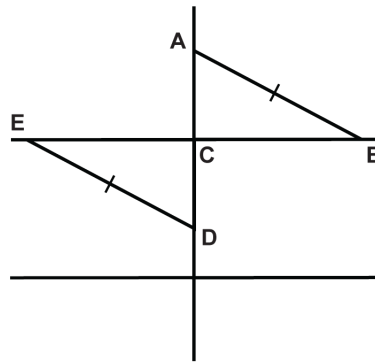

TABLE 4.19:

Statement	Reason
1. $\angle ACB$ and $\angle DCE$ are right angles.	(4.)
2. (5.)	Definition of midpoint
3. (6.)	Given
4. $\triangle ACD \cong \triangle DCE$	(7.)

Based on the following details, are the two right triangles definitively congruent?

8. The hypotenuses of two right triangles are congruent.
9. Both sets of legs in the two right triangles are congruent.
10. One set of legs are congruent in the two right triangles.
11. The hypotenuses and one pair of legs are congruent in the two right triangles.
12. One of the non right angles of the two right triangles is congruent.
13. All of the angles of the two right triangles are congruent.
14. All of the sides of the two right triangles are congruent.
15. Both triangles have one leg that is twice the length of the other.

4.10 Isosceles Triangles

Here you'll learn the definition of an isosceles triangle as well as two theorems about isosceles triangles: 1) The angle bisector of the vertex is the perpendicular bisector of the base; and 2) The base angles are congruent.

What if you were presented with an isosceles triangle and told that its base angles measure x° and y° ? What could you conclude about x and y ? After completing this Concept, you'll be able to apply important properties about isosceles triangles to help you solve problems like this one.

Watch This



MEDIA

Click image to the left for more content.

CK-12

Watch the first part of this video.

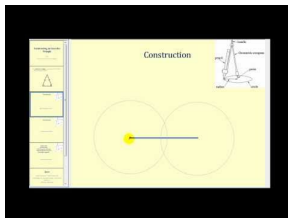

MEDIA

Click image to the left for more content.

James Sousa:HowTo Construct AnIsosceles Triangle

Then watch this video.

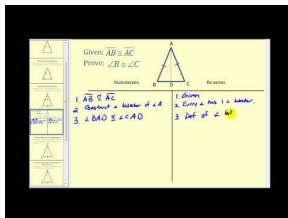

MEDIA

Click image to the left for more content.

James Sousa:Proof of the Isosceles TriangleTheorem

Finally, watch this video.

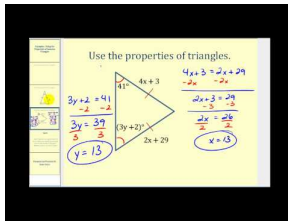

MEDIA

Click image to the left for more content.

James Sousa:Using the Properties of Isosceles Triangles to Determine Values

Guidance

An isosceles triangle is a triangle that has **at least** two congruent sides. The congruent sides of the isosceles triangle are called the **legs**. The other side is called the **base**. The angles between the base and the legs are called **base angles**. The angle made by the two legs is called the **vertex angle**. One of the important properties of isosceles triangles is that their base angles are always congruent. This is called the **Base Angles Theorem**.

For $\triangle DEF$, if $\overline{DE} \cong \overline{EF}$, then $\angle D \cong \angle F$.

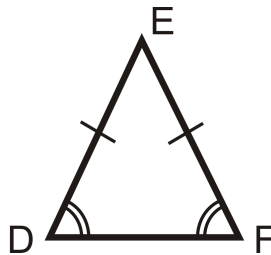

Another important property of isosceles triangles is that the angle bisector of the vertex angle is also the perpendicular bisector of the base. This is called the **Isosceles Triangle Theorem**. (Note this is **ONLY** true of the vertex angle.) The converses of the Base Angles Theorem and the Isosceles Triangle Theorem are both true as well.

Base Angles Theorem Converse: If two angles in a triangle are congruent, then the sides opposite those angles are also congruent. So for $\triangle DEF$, if $\angle D \cong \angle F$, then $\overline{DE} \cong \overline{EF}$.

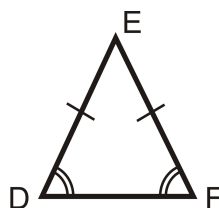

Isosceles Triangle Theorem Converse: The perpendicular bisector of the base of an isosceles triangle is also the angle bisector of the vertex angle. So for isosceles $\triangle DEF$, if $\overline{EG} \perp \overline{DF}$ and $\overline{DG} \cong \overline{GF}$, then $\angle DEG \cong \angle FEG$.

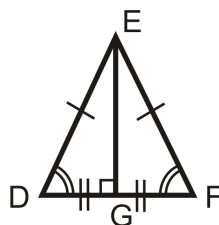

Example A

Which two angles are congruent?

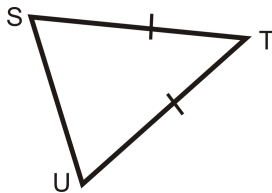

This is an isosceles triangle. The congruent angles are opposite the congruent sides. From the arrows we see that $\angle S \cong \angle U$.

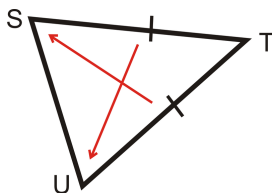
**Example B**

If an isosceles triangle has base angles with measures of 47° , what is the measure of the vertex angle?

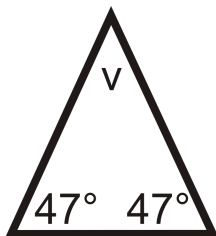

Draw a picture and set up an equation to solve for the vertex angle, v . Remember that the three angles in a triangle always add up to 180° .

$$\begin{aligned} 47^\circ + 47^\circ + v &= 180^\circ \\ v &= 180^\circ - 47^\circ - 47^\circ \\ v &= 86^\circ \end{aligned}$$

Example C

If an isosceles triangle has a vertex angle with a measure of 116° , what is the measure of each base angle?

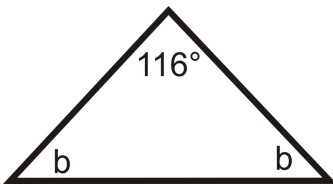

Draw a picture and set up an equation to solve for the base angles, b .

$$116^\circ + b + b = 180^\circ$$

$$2b = 64^\circ$$

$$b = 32^\circ$$



MEDIA

Click image to the left for more content.

CK-12 Isosceles Triangles

Guided Practice

1. Find the value of x and the measure of each angle.

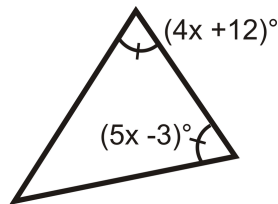

2. Find the measure of x .



3. True or false: Base angles of an isosceles triangle can be right angles.

Answers:

1. The two angles are equal, so set them equal to each other and solve for x .

$$(4x + 12)^\circ = (5x - 3)^\circ$$

$$15 = x$$

Substitute $x = 15$; the base angles are $[4(15) + 12]^\circ$, or 72° . The vertex angle is $180^\circ - 72^\circ - 72^\circ = 36^\circ$.

2. The two sides are equal, so set them equal to each other and solve for x .

$$2x - 9 = x + 5$$

$$x = 14$$

3. This statement is false. Because the base angles of an isosceles triangle are congruent, if one base angle is a right angle then both base angles must be right angles. It is impossible to have a triangle with two right (90°) angles. The Triangle Sum Theorem states that the sum of the three angles in a triangle is 180° . If two of the angles in a triangle are right angles, then the third angle must be 0° and the shape is no longer a triangle.

Practice

Find the measures of x and/or y .

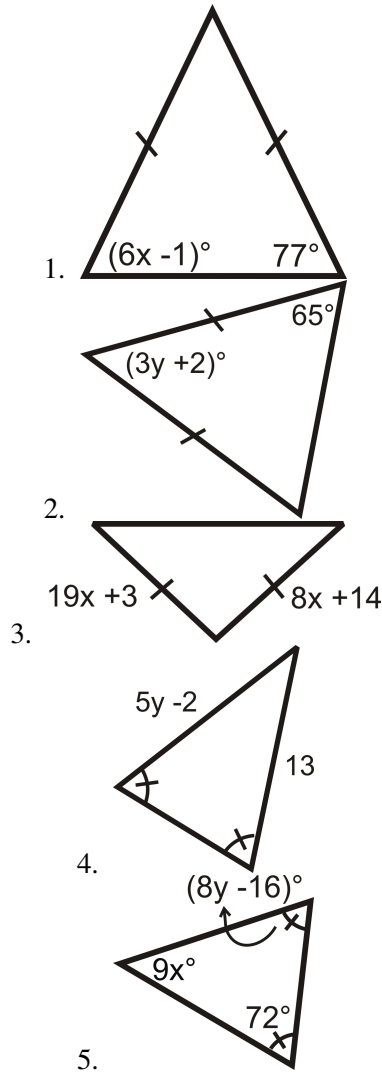

Determine if the following statements are true or false.

- 6. Base angles of an isosceles triangle are congruent.
- 7. Base angles of an isosceles triangle are complementary.
- 8. Base angles of an isosceles triangle can be equal to the vertex angle.
- 9. Base angles of an isosceles triangle are acute.

Fill in the proofs below.

- 10. Given: Isosceles $\triangle CIS$, with base angles $\angle C$ and $\angle S$ \overline{IT} is the angle bisector of $\angle CIS$ Prove: \overline{IT} is the perpendicular bisector of \overline{CS}

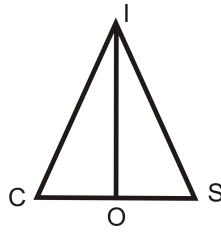

TABLE 4.20:

<i>Statement</i>	<i>Reason</i>
1.	1. Given
2.	2. Base Angles Theorem
3. $\angle CIO \cong \angle SIO$	3.
4.	4. Reflexive PoC
5. $\triangle CIO \cong \triangle SIO$	5.
6. $\overline{CO} \cong \overline{OS}$	6.
7.	7. CPCTC
8. $\angle IOC$ and $\angle IOS$ are supplementary	8.
9.	9. Congruent Supplements Theorem
10. \overline{IO} is the perpendicular bisector of \overline{CS}	10.

11. Given: Isosceles $\triangle ICS$ with $\angle C$ and $\angle S$ Prove: \overline{IO} is the angle bisector of $\angle CIS$

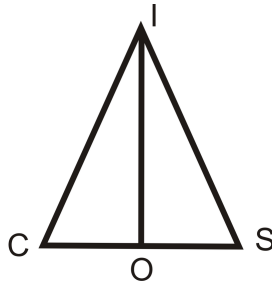

TABLE 4.21:

<i>Statement</i>	<i>Reason</i>
1.	1.
2. $\angle C \cong \angle S$	2.
3. $\overline{CO} \cong \overline{OS}$	3.
4. $m\angle IOC = m\angle IOS = 90^\circ$	4.
5.	5.
6.	6. CPCTC
7. \overline{IO} is the angle bisector of $\angle CIS$	7.

On the $x - y$ plane, plot the coordinates and determine if the given three points make a scalene or isosceles triangle.

12. (-2, 1), (1, -2), (-5, -2)
13. (-2, 5), (2, 4), (0, -1)
14. (6, 9), (12, 3), (3, -6)
15. (-10, -5), (-8, 5), (2, 3)
16. (-1, 2), (7, 2), (3, 9)

4.11 Equilateral Triangles

Here you'll learn the definition of an equilateral triangle as well as an important theorem about equilateral triangles: Equilateral triangles are always equiangular.

What if you were presented with an equilateral triangle and told that its sides measure x , y , and 8? What could you conclude about x and y ? After completing this Concept, you'll be able to apply important properties about equilateral triangles to help you solve problems like this one.

Watch This



MEDIA

Click image to the left for more content.

CK-12 Equilateral Triangles

Watch this video first.

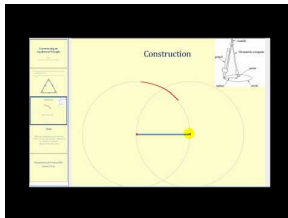

MEDIA

Click image to the left for more content.

James Sousa:Constructing anEquilateralTriangle

Now watch this video.

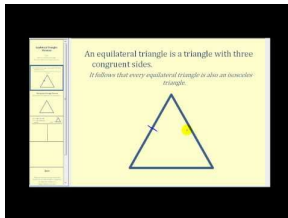

MEDIA

Click image to the left for more content.

James Sousa:EquilateralTriangles Theorem

Finally, watch this video.

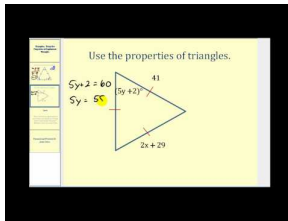

MEDIA

Click image to the left for more content.

James Sousa:Using the Properties of Equilateral Triangles

Guidance

All sides in an **equilateral triangle** have the same length. One important property of equilateral triangles is that all of their angles are congruent (and thus 60° each). This is called the **Equilateral Triangle Theorem** and can be derived from the **Base Angles Theorem**.

Equilateral Triangle Theorem: All equilateral triangles are also equiangular. Furthermore, all equiangular triangles are also equilateral.

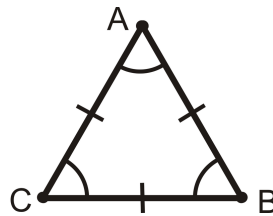

If $\overline{AB} \cong \overline{BC} \cong \overline{AC}$, then $\angle A \cong \angle B \cong \angle C$. Conversely, if $\angle A \cong \angle B \cong \angle C$, then $\overline{AB} \cong \overline{BC} \cong \overline{AC}$.

Example A

Find the value of x .

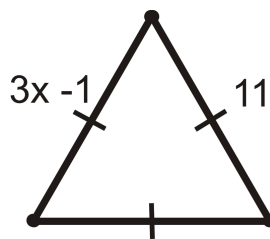

Solution: Because this is an equilateral triangle $3x - 1 = 11$. Solve for x .

$$\begin{aligned} 3x - 1 &= 11 \\ 3x &= 12 \\ x &= 4 \end{aligned}$$

Example B

Find the values of x and y .

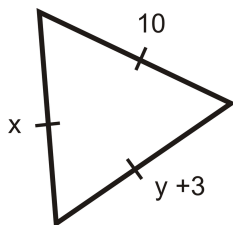

The markings show that this is an equilateral triangle since all sides are congruent. This means all sides must equal 10. We have $x = 10$ and $y + 3 = 10$ which means that $y = 7$.

Example C

Two sides of an equilateral triangle are $2x + 5$ units and $x + 13$ units. How long is each side of this triangle?

The two given sides must be equal because this is an equilateral triangle. Write and solve the equation for x .

$$\begin{aligned} 2x + 5 &= x + 13 \\ x &= 8 \end{aligned}$$

To figure out how long each side is, plug in 8 for x in either of the original expressions. $2(8) + 5 = 21$. Each side is 21 units.



MEDIA

Click image to the left for more content.

CK-12 Equilateral Triangles

Guided Practice

- Find the measure of y .

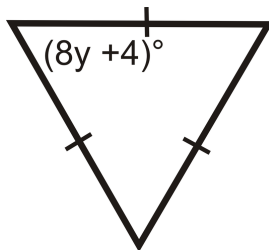

- Fill in the proof:

Given: Equilateral $\triangle RST$ with

$$\overline{RT} \cong \overline{ST} \cong \overline{RS}$$

Prove: $\triangle RST$ is equiangular

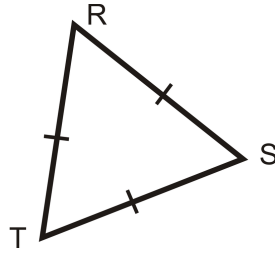

TABLE 4.22:

<i>Statement</i>	<i>Reason</i>
1.	1. Given
2.	2. Base Angles Theorem
3.	3. Base Angles Theorem
4.	4. Transitive PoC
5. $\triangle RST$ is equiangular	5.

3. True or false: All equilateral triangles are isosceles triangles.

Answers:

1. The markings show that all angles are congruent. Since all three angles must add up to 180° this means that each angle must equal 60° . Write and solve an equation:

$$\begin{aligned} 8y + 4 &= 60 \\ 8y &= 56 \\ y &= 7 \end{aligned}$$

2.

TABLE 4.23:

<i>Statement</i>	<i>Reason</i>
1. $\overline{RT} \cong \overline{ST} \cong \overline{RS}$	1. Given
2. $\angle R \cong \angle S$	2. Base Angles Theorem
3. $\angle T \cong \angle R$	3. Base Angles Theorem
4. $\angle T \cong \angle S$	4. Transitive PoC
5. $\triangle RST$ is equiangular	5. Definition of equiangular.

3. This statement is true. The definition of an isosceles triangle is a triangle with at least two congruent sides. Since all equilateral triangles have three congruent sides, they fit the definition of an isosceles triangle.

Practice

The following triangles are equilateral triangles. Solve for the unknown variables.

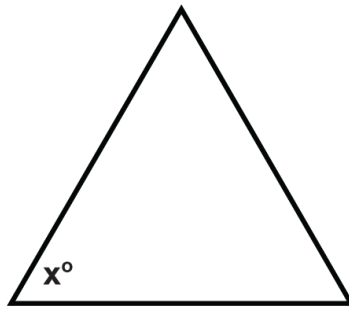

1.

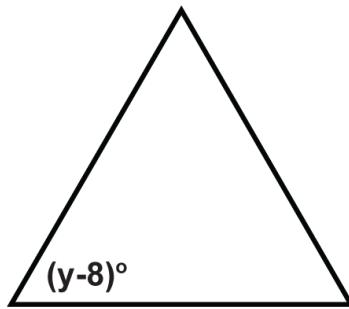

2.

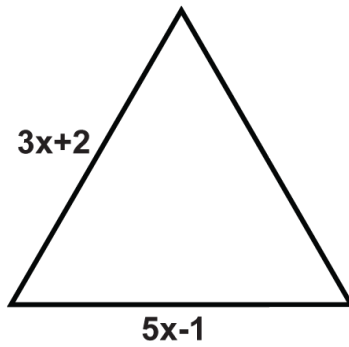

3.

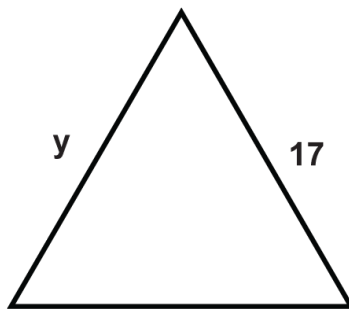

4.

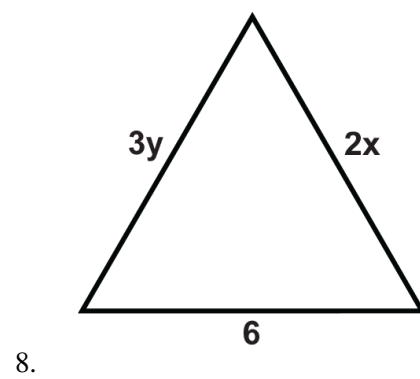
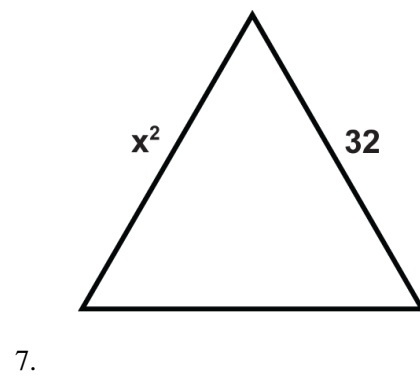
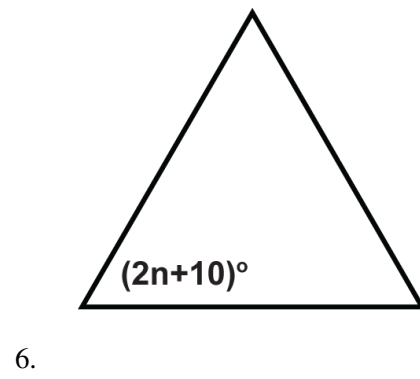
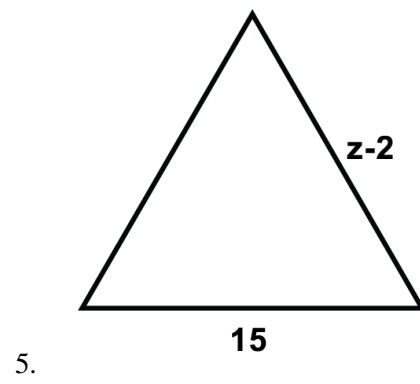

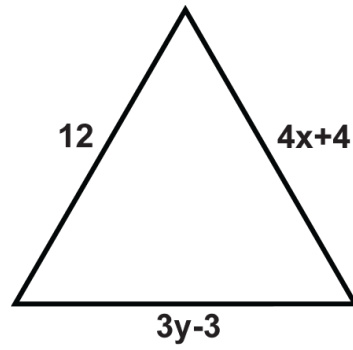

9.

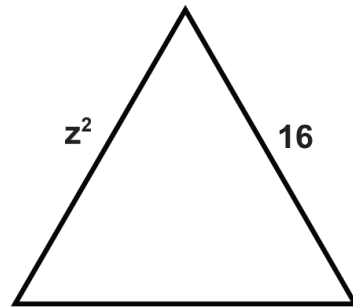

10.

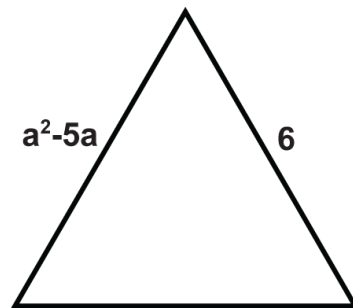

11.

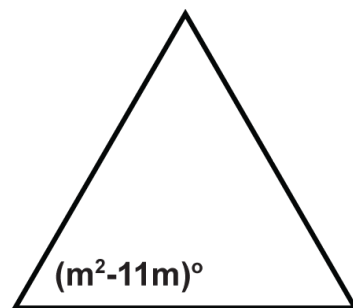

12.

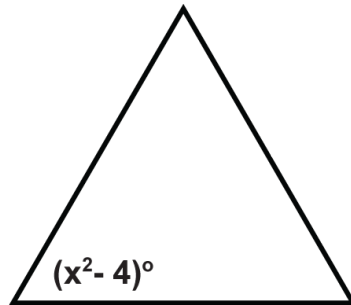
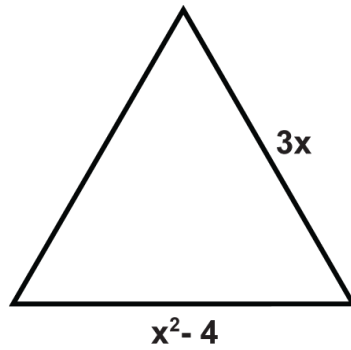

15. Find the measures of x and y .

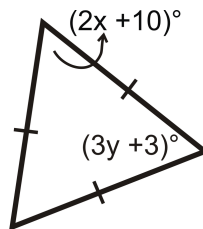

Summary

This chapter begins by showing that the sum of the angles in a triangle is a constant. From the Triangle Sum Theorem, theorems related to the exterior angles of a triangle are developed. The definition of congruency is presented and from that foundation the chapter presents other important theorems related to congruent triangles, such as the Third Angle Theorem and the SSS, SAS, ASA, AAS and HL Triangle Congruency Theorems. Isosceles triangles and equilateral triangles are compared and explored.

CHAPTER

5**Triangle Relationships****Chapter Outline**

- 5.1 MIDSEGMENT THEOREM**
 - 5.2 PERPENDICULAR BISECTORS**
 - 5.3 ANGLE BISECTORS IN TRIANGLES**
 - 5.4 MEDIANS**
 - 5.5 ALTITUDES**
 - 5.6 COMPARING ANGLES AND SIDES IN TRIANGLES**
 - 5.7 TRIANGLE INEQUALITY THEOREM**
 - 5.8 INDIRECT PROOF IN ALGEBRA AND GEOMETRY**
-

Introduction

In this chapter we will explore the properties of midsegments, perpendicular bisectors, angle bisectors, medians, and altitudes. Next, we will look at the relationship of the sides of a triangle and how the sides of one triangle can compare to another.

5.1 Midsegment Theorem

Here you'll learn what a midsegment is and how to use the Midsegment Theorem.

What if you were given $\triangle FGH$ and told that \overline{JK} was its midsegment? How could you find the length of JK given the length of the triangle's third side, FH ? After completing this Concept, you'll be able to use the Midsegment Theorem to solve problems like this one.

Watch This



MEDIA

Click image to the left for more content.

CK-12 Midsegment Theorem

First watch this video.

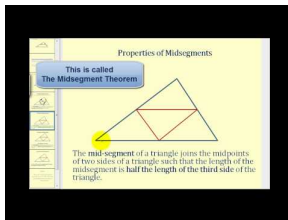

MEDIA

Click image to the left for more content.

James Sousa: Introduction to the Midsegments of a Triangle

Now watch this video.

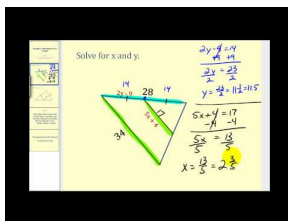

MEDIA

Click image to the left for more content.

James Sousa: Determining Unknown Values Using Properties of the Midsegments of a Triangle

Guidance

A line segment that connects two midpoints of the sides of a triangle is called a **midsegment**. \overline{DF} is the midsegment between \overline{AB} and \overline{BC} .

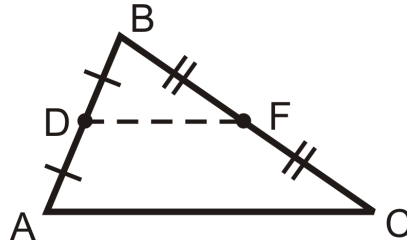

The tic marks show that D and F are midpoints. $\overline{AD} \cong \overline{DB}$ and $\overline{BF} \cong \overline{FC}$. For every triangle there are three midsegments.

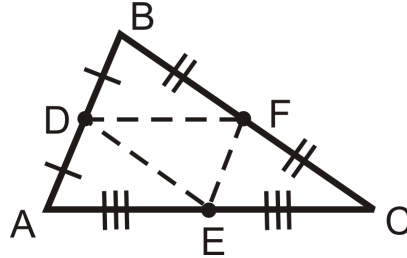

There are two important properties of midsegments that combine to make the **Midsegment Theorem**. The **Midsegment Theorem** states that the midsegment connecting the midpoints of two sides of a triangle is parallel to the third side of the triangle, and the length of this midsegment is half the length of the third side. So, if \overline{DF} is a midsegment of $\triangle ABC$, then $DF = \frac{1}{2}AC = AE = EC$ and $\overline{DF} \parallel \overline{AC}$.

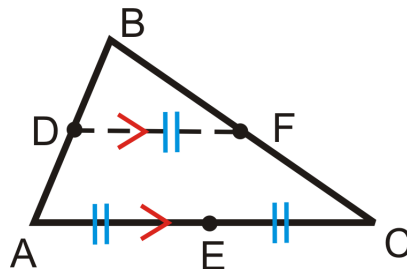

Note that there are two important ideas here. One is that the midsegment is parallel to a side of the triangle. The other is that the midsegment is always half the length of this side. To play with the properties of midsegments, go to <http://www.mathopenref.com/trianglemidsegment.html>.

Example A

The vertices of $\triangle LMN$ are $L(4,5)$, $M(-2,-7)$ and $N(-8,3)$. Find the midpoints of all three sides, label them O , P and Q . Then, graph the triangle, plot the midpoints and draw the midsegments.

To solve this problem, use the midpoint formula 3 times to find all the midpoints. Recall that the midpoint formula is $\left(\frac{x_1+x_2}{2}, \frac{y_1+y_2}{2}\right)$.

$$L \text{ and } M = \left(\frac{4+(-2)}{2}, \frac{5+(-7)}{2}\right) = (1, -1) \text{ point } O$$

$$M \text{ and } N = \left(\frac{-2+(-8)}{2}, \frac{-7+3}{2}\right) = (-5, -2), \text{ point } P$$

$$L \text{ and } N = \left(\frac{4+(-8)}{2}, \frac{5+3}{2}\right) = (-2, 4), \text{ point } Q$$

The graph is to the right.

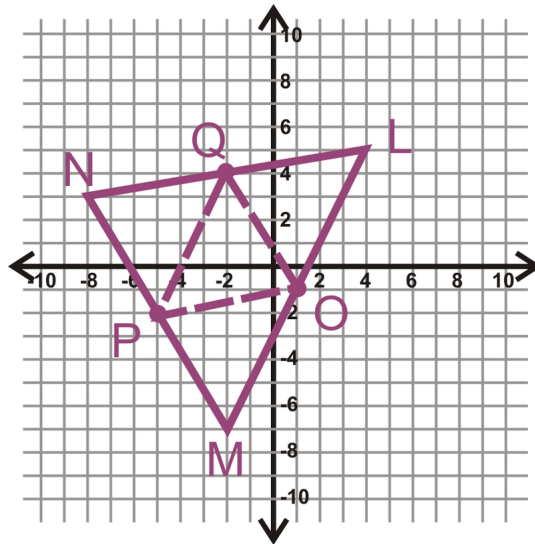

Example B

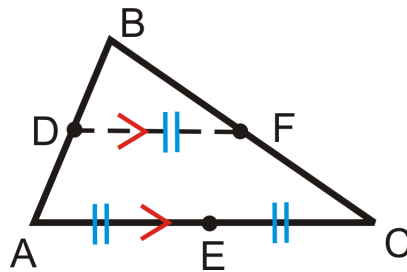

Mark all the congruent segments on $\triangle ABC$ with midpoints D , E , and F .

Drawing in all three midsegments, we have:

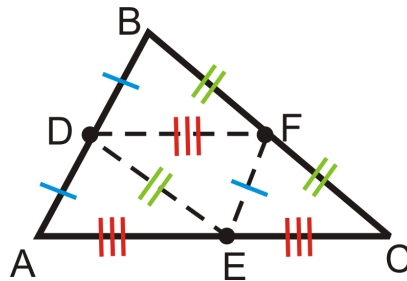

Also, this means the four smaller triangles are congruent by SSS.

Now, mark all the parallel lines on $\triangle ABC$, with midpoints D , E , and F .

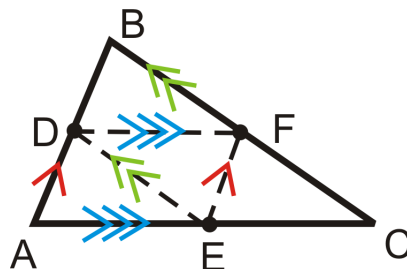

Example C

M , N , and O are the midpoints of the sides of $\triangle XYZ$.

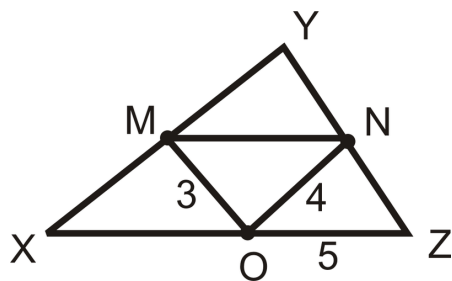

Find

- MN
- XY
- The perimeter of $\triangle XYZ$

To solve, use the Midsegment Theorem.

- $MN = OZ = 5$
- $XY = 2(ON) = 2 \cdot 4 = 8$
- Add up the three sides of $\triangle XYZ$ to find the perimeter.

$$XY + YZ + XZ = 2 \cdot 4 + 2 \cdot 3 + 2 \cdot 5 = 8 + 6 + 10 = 24$$

Remember: No line segment over MN means length or distance.



MEDIA

Click image to the left for more content.

CK-12 Midsegment Theorem

Guided Practice

- Find the value of x and AB . A and B are midpoints.

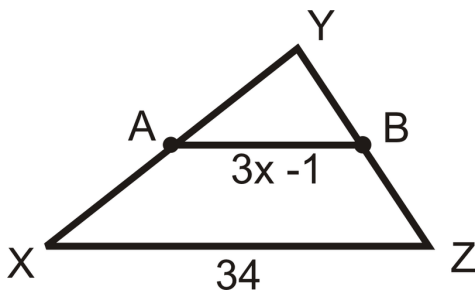

- True or false: If a line passes through two sides of a triangle and is parallel to the third side, then it is a midsegment.
- Find y . You may assume that the line segment within the triangle is a midsegment.

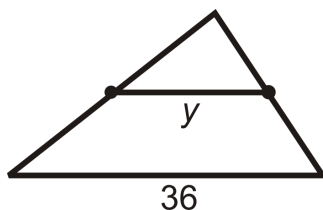
**Answers:**

- $AB = 34 \div 2 = 17$. To find x , set $3x - 1$ equal to 17.

$$\begin{aligned} 3x - 1 &= 17 \\ 3x &= 18 \\ x &= 6 \end{aligned}$$

- This statement is false. A line that passes through two sides of a triangle is only a midsegment if it passes through the **midpoints** of the two sides of the triangle.
- Because a midsegment is always half the length of the side it is parallel to, we know that $y = \frac{1}{2}(36) = 18$.

Practice

Determine whether each statement is true or false.

- The endpoints of a midsegment are midpoints.
- A midsegment is parallel to the side of the triangle that it does not intersect.
- There are three congruent triangles formed by the midsegments and sides of a triangle.
- There are three midsegments in every triangle.

R , S , T , and U are midpoints of the sides of $\triangle XPO$ and $\triangle YPO$.

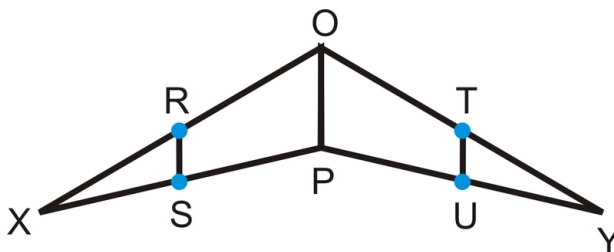

- If $OP = 12$, find RS and TU .
- If $RS = 8$, find TU .
- If $RS = 2x$, and $OP = 20$, find x and TU .
- If $OP = 4x$ and $RS = 6x - 8$, find x .

For questions 9-15, find the indicated variable(s). You may assume that all line segments within a triangle are midsegments.

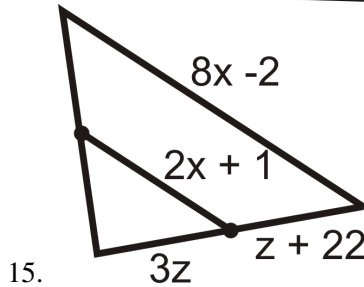
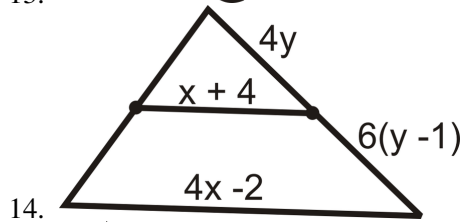
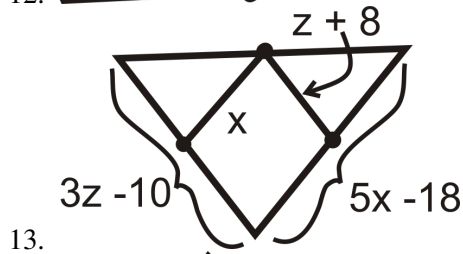
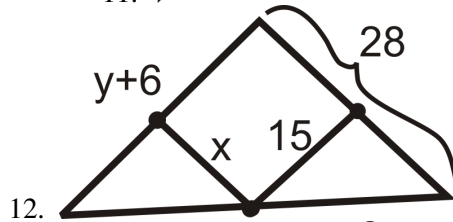
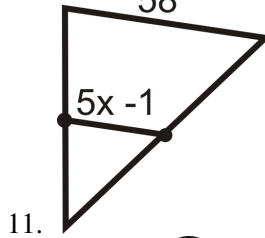
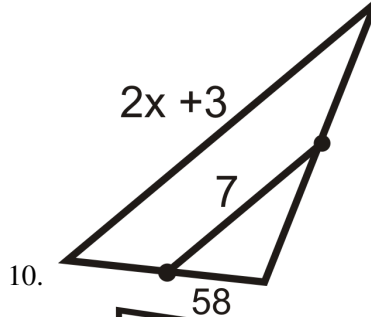
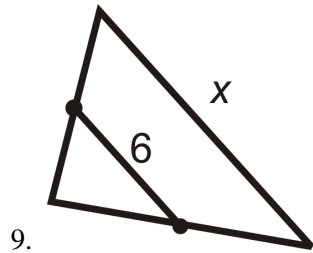

16. The sides of $\triangle XYZ$ are 26, 38, and 42. $\triangle ABC$ is formed by joining the midpoints of $\triangle XYZ$.

a. What are the lengths of the sides of $\triangle ABC$?

- b. Find the perimeter of $\triangle ABC$.
- c. Find the perimeter of $\triangle XYZ$.
- d. What is the relationship between the perimeter of a triangle and the perimeter of the triangle formed by connecting its midpoints?

Coordinate Geometry Given the vertices of $\triangle ABC$ below find the midpoints of each side.

17. $A(5, -2)$, $B(9, 4)$ and $C(-3, 8)$
18. $A(-10, 1)$, $B(4, 11)$ and $C(0, -7)$
19. $A(-1, 3)$, $B(5, 7)$ and $C(9, -5)$
20. $A(-4, -15)$, $B(2, -1)$ and $C(-20, 11)$

5.2 Perpendicular Bisectors

Here you'll learn what a perpendicular bisector is and the Perpendicular Bisector Theorem, which states that if a point is on the perpendicular bisector of a segment, then it is equidistant from the endpoints of the segment.

What if you were given $\triangle FGH$ and told that \overleftrightarrow{GJ} was the perpendicular bisector of \overline{FH} ? How could you find the length of FG given the length of GH ? After completing this Concept, you'll be able to use the Perpendicular Bisector Theorem to solve problems like this one.

Watch This



MEDIA

Click image to the left for more content.

CK-12 Perpendicular Bisectors

First watch this video.

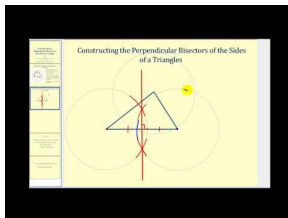

MEDIA

Click image to the left for more content.

James Sousa:Constructing Perpendicular Bisectors

Next watch this video.

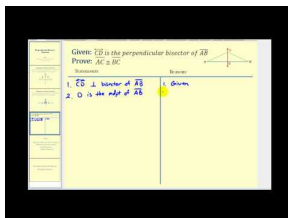

MEDIA

Click image to the left for more content.

James Sousa:Proof of the Perpendicular Bisector Theorem

Then watch this video.

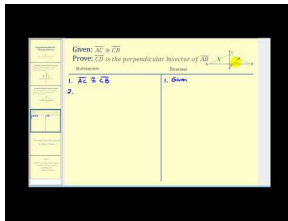

MEDIA

Click image to the left for more content.

James Sousa:Proof of the Perpendicular Bisector Theorem Converse

Finally, watch this video.

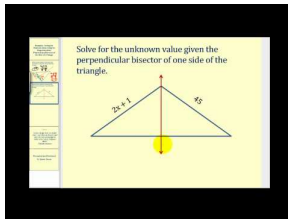

MEDIA

Click image to the left for more content.

James Sousa:Determining Values Using Perpendicular Bisectors

Guidance

A **perpendicular bisector** is a line that intersects a line segment at its midpoint and is perpendicular to that line segment, as shown in the construction below.

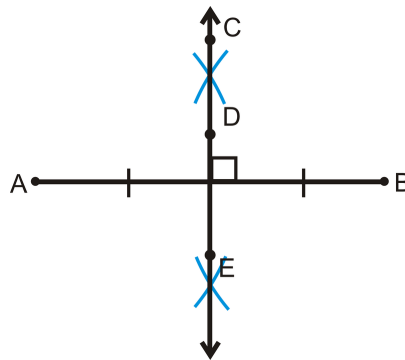

One important property related to perpendicular bisectors is that if a point is on the perpendicular bisector of a segment, then it is equidistant from the endpoints of the segment. This is called the **Perpendicular Bisector Theorem**.

If $\overleftrightarrow{CD} \perp \overline{AB}$ and $AD = DB$, then $AC = CB$.

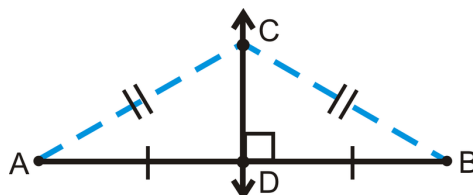

In addition to the Perpendicular Bisector Theorem, the converse is also true.

Perpendicular Bisector Theorem Converse: If a point is equidistant from the endpoints of a segment, then the point is on the perpendicular bisector of the segment.

Using the picture above: If $AC = CB$, then $\overleftrightarrow{CD} \perp \overline{AB}$ and $AD = DB$.

When we construct perpendicular bisectors for the sides of a triangle, they meet in one point. This point is called the **circumcenter** of the triangle.

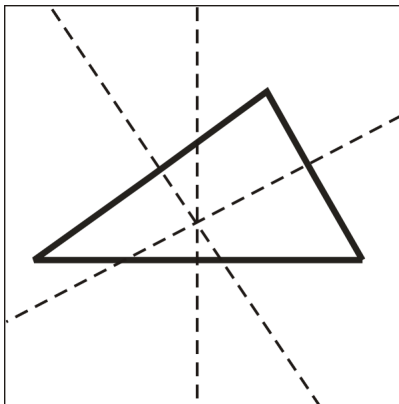

Example A

If \overleftrightarrow{MO} is the perpendicular bisector of \overline{LN} and $LO = 8$, what is ON ?

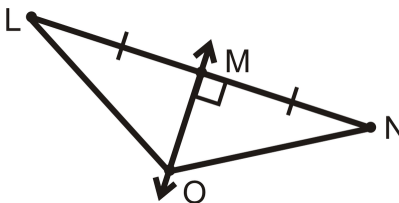

By the Perpendicular Bisector Theorem, $LO = ON$. So, $ON = 8$.

Example B

Find x and the length of each segment.

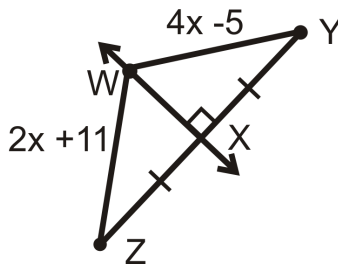

\overleftrightarrow{WX} is the perpendicular bisector of \overline{YZ} and from the Perpendicular Bisector Theorem $WZ = WY$.

$$\begin{aligned} 2x + 11 &= 4x - 5 \\ 16 &= 2x \\ 8 &= x \end{aligned}$$

$$WZ = WY = 2(8) + 11 = 16 + 11 = 27.$$

Example C

Find the value of x . m is the perpendicular bisector of AB .

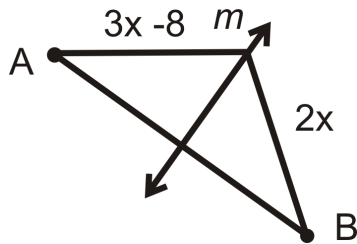

By the Perpendicular Bisector Theorem, both segments are equal. Set up and solve an equation.

$$\begin{aligned} 3x - 8 &= 2x \\ x &= 8 \end{aligned}$$

**MEDIA**

Click image to the left for more content.

CK-12 Perpendicular Bisectors

Guided Practice

1. \overleftrightarrow{OQ} is the perpendicular bisector of \overline{MP} .

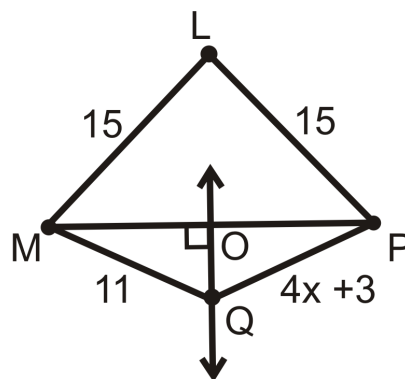

- Which line segments are equal?
 - Find x .
 - Is L on \overleftrightarrow{OQ} ? How do you know?
2. Find the value of x . m is the perpendicular bisector of AB .

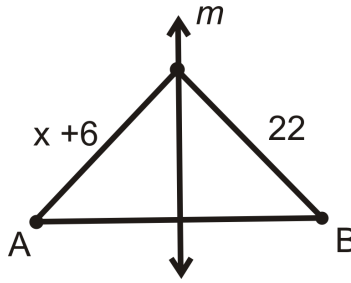

3. Determine if \overleftrightarrow{ST} is the perpendicular bisector of \overline{XY} . Explain why or why not.

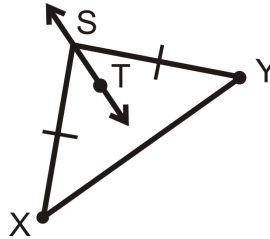

Answers:

1. a) $ML = LP$, $MO = OP$, and $MQ = QP$.

b)

$$\begin{aligned} 4x + 3 &= 11 \\ 4x &= 8 \\ x &= 2 \end{aligned}$$

c) Yes, L is on \overleftrightarrow{OQ} because $ML = LP$ (the Perpendicular Bisector Theorem Converse).

2. By the Perpendicular Bisector Theorem, both segments are equal. Set up and solve an equation.

$$\begin{aligned} x + 6 &= 22 \\ x &= 16 \end{aligned}$$

3. \overleftrightarrow{ST} is not necessarily the perpendicular bisector of \overline{XY} because not enough information is given in the diagram. There is no way to know from the diagram if \overleftrightarrow{ST} will extend to make a right angle with \overline{XY} .

Practice

For questions 1-4, find the value of x . m is the perpendicular bisector of AB .

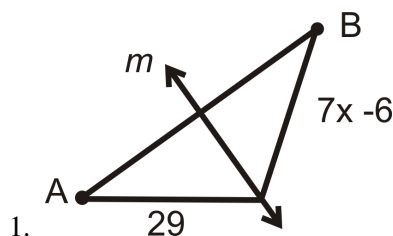

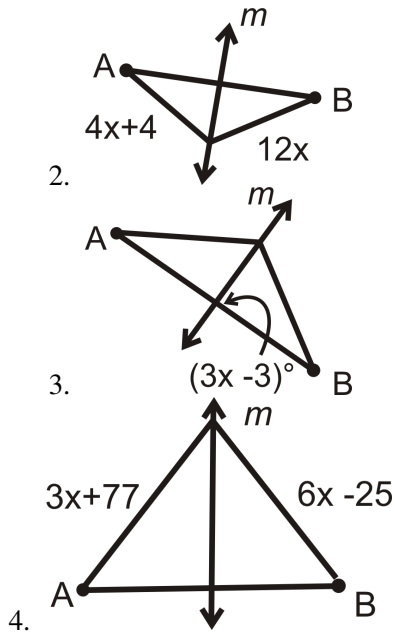

m is the perpendicular bisector of \overline{AB} .

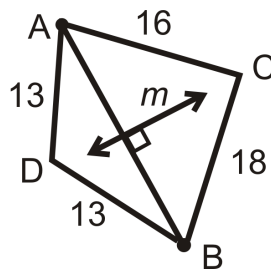

5. List all the congruent segments.
6. Is C on m ? Why or why not?
7. Is D on m ? Why or why not?

For Question 8, determine if \overleftrightarrow{ST} is the perpendicular bisector of \overline{XY} . Explain why or why not.

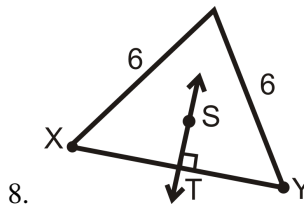

9. In what type of triangle will all perpendicular bisectors pass through vertices of the triangle?
10. Fill in the blanks of the proof of the Perpendicular Bisector Theorem.

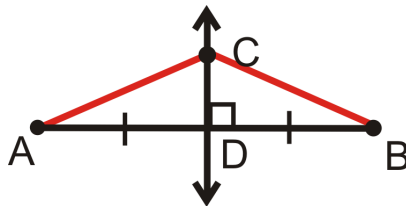

Given: \overleftrightarrow{CD} is the perpendicular bisector of \overline{AB}

Prove: $\overline{AC} \cong \overline{CB}$

TABLE 5.1:

<i>Statement</i>	<i>Reason</i>
1.	1.
2. D is the midpoint of \overline{AB}	2.
3.	3. Definition of a midpoint
4. $\angle CDA$ and $\angle CDB$ are right angles	4.
5. $\angle CDA \cong \angle CDB$	5.
6.	6. Reflexive PoC
7. $\triangle CDA \cong \triangle CDB$	7.
8. $\overline{AC} \cong \overline{CB}$	8.

5.3 Angle Bisectors in Triangles

Here you'll learn what an angle bisector is as well as the Angle Bisector Theorem, which states that if a point is on the bisector of an angle, then the point is equidistant from the sides of the angle.

What if you were told that \overrightarrow{GJ} is the angle bisector of $\angle FGH$? How would you find the length of FJ given the length of HJ ? After completing this Concept, you'll be able to use the Angle Bisector Theorem to solve problems like this one.

Watch This



MEDIA

Click image to the left for more content.

CK-12 Angle Bisectors

First watch this video.

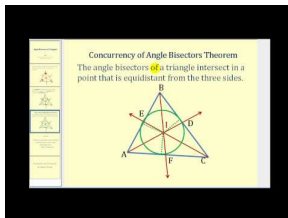

MEDIA

Click image to the left for more content.

James Sousa:Introduction to Angle Bisectors

Next watch this video.

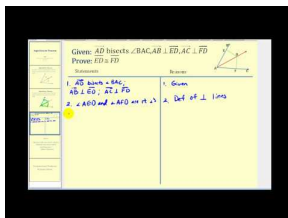

MEDIA

Click image to the left for more content.

James Sousa:Proof of the Angle Bisector Theorem

Then watch this video.

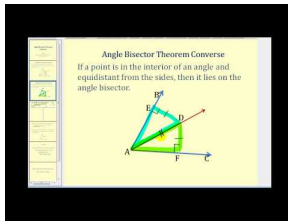

MEDIA

Click image to the left for more content.

[James Sousa:Proof of the Angle Bisector Theorem Converse](#)

Finally, watch this video.

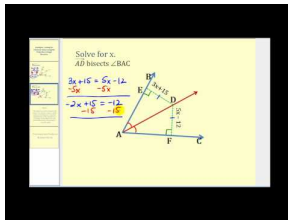

MEDIA

Click image to the left for more content.

[James Sousa:Solving For Unknown Values Using Angle Bisectors](#)

Guidance

An **angle bisector** cuts an angle exactly in half. One important property of angle bisectors is that if a point is on the bisector of an angle, then the point is equidistant from the sides of the angle. This is called the **Angle Bisector Theorem**.

In other words, if \overrightarrow{BD} bisects $\angle ABC$, $\overrightarrow{BA} \perp \overrightarrow{FD}$, and $\overrightarrow{BC} \perp \overrightarrow{DG}$ then $FD = DG$.

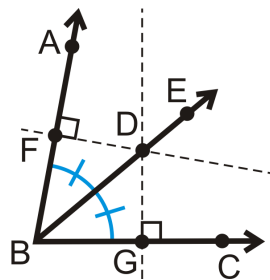

The converse of this theorem is also true.

Angle Bisector Theorem Converse: If a point is in the interior of an angle and equidistant from the sides, then it lies on the bisector of that angle.

When we construct angle bisectors for the angles of a triangle, they meet in one point. This point is called the **incenter** of the triangle.

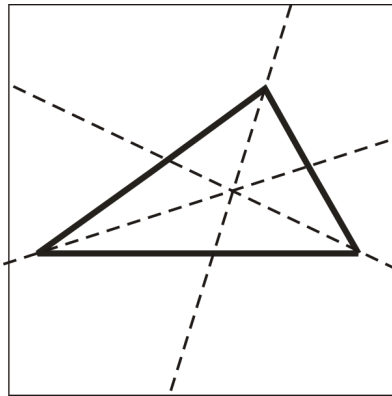
**Example A**

Is Y on the angle bisector of $\angle XWZ$?

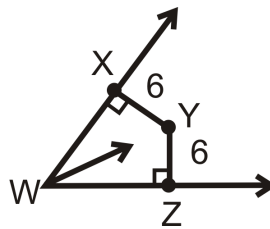

If Y is on the angle bisector, then $XY = YZ$ and both segments need to be perpendicular to the sides of the angle. From the markings we know $\overline{XY} \perp \overline{WX}$ and $\overline{ZY} \perp \overline{WZ}$. Second, $XY = YZ = 6$. So, yes, Y is on the angle bisector of $\angle XWZ$.

Example B

\overrightarrow{MO} is the angle bisector of $\angle LMN$. Find the measure of x .

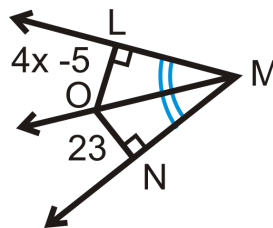

$LO = ON$ by the Angle Bisector Theorem.

$$\begin{aligned} 4x - 5 &= 23 \\ 4x &= 28 \\ x &= 7 \end{aligned}$$

Example C

\overrightarrow{AB} is the angle bisector of $\angle CAD$. Solve for the missing variable.

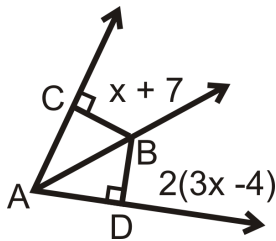

$CB = BD$ by the Angle Bisector Theorem, so we can set up and solve an equation for x .

$$\begin{aligned} x + 7 &= 2(3x - 4) \\ x + 7 &= 6x - 8 \\ 15 &= 5x \\ x &= 3 \end{aligned}$$



MEDIA

Click image to the left for more content.

CK-12 Angle Bisectors

Guided Practice

1. \vec{AB} is the angle bisector of $\angle CAD$. Solve for the missing variable.

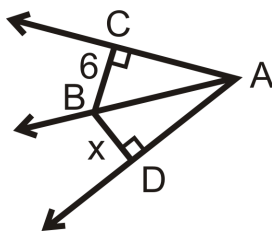

2. Is there enough information to determine if \vec{AB} is the angle bisector of $\angle CAD$? Why or why not?

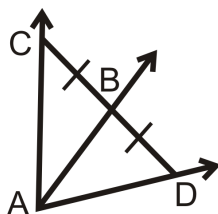

3. A 108° angle is bisected. What are the measures of the resulting angles?

Answers:

1. $CB = BD$ by the Angle Bisector Theorem, so $x = 6$.

2. No because B is not necessarily equidistant from \overline{AC} and \overline{AD} . We do not know if the angles in the diagram are right angles.

3. We know that to bisect means to cut in half, so each of the resulting angles will be half of 108. The measure of each resulting angle is 54° .

Practice

For questions 1-4, \overrightarrow{AB} is the angle bisector of $\angle CAD$. Solve for the missing variable.

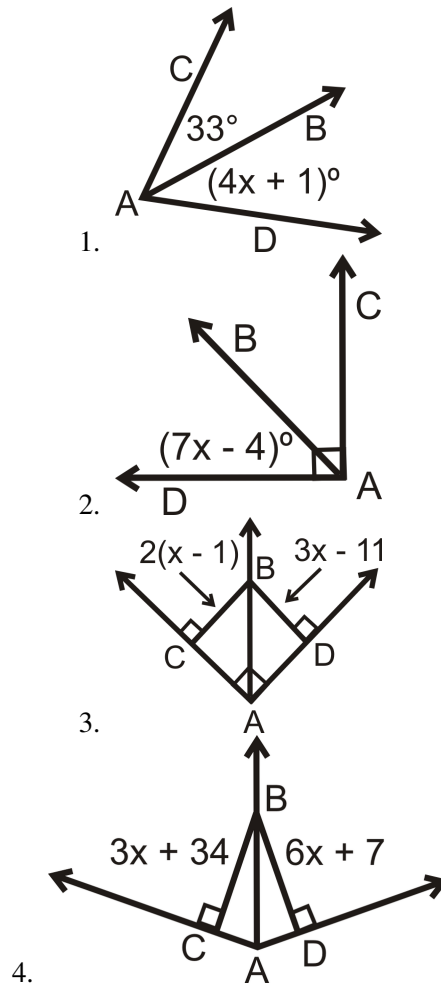

Is there enough information to determine if \overrightarrow{AB} is the angle bisector of $\angle CAD$? Why or why not?

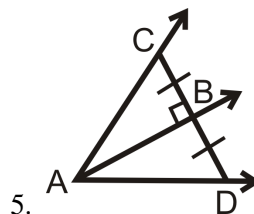

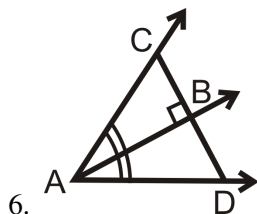

7. In what type of triangle will all angle bisectors pass through vertices of the triangle?
8. What is another name for the angle bisectors of the vertices of a square?
9. Draw in the angle bisectors of the vertices of a square. How many triangles do you have? What type of triangles are they?
10. Fill in the blanks in the Angle Bisector Theorem Converse.

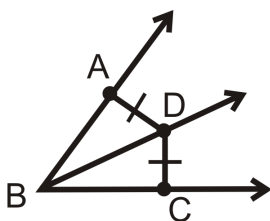

Given: $\overline{AD} \cong \overline{DC}$, such that AD and DC are the shortest distances to \overrightarrow{BA} and \overrightarrow{BC}

Prove: \overrightarrow{BD} bisects $\angle ABC$

TABLE 5.2:

<i>Statement</i>	<i>Reason</i>
1.	1.
2.	2. The shortest distance from a point to a line is perpendicular.
3. $\angle DAB$ and $\angle DCB$ are right angles	3.
4. $\angle DAB \cong \angle DCB$	4.
5. $\overline{BD} \cong \overline{BD}$	5.
6. $\triangle ABD \cong \triangle CBD$	6.
7.	7. CPCTC
8. \overrightarrow{BD} bisects $\angle ABC$	8.

5.4 Medians

Here you'll learn the definitions of median and centroid as well as the Median Theorem, which states that the medians of a triangle intersect at a point that is two-thirds of the distance from the vertices to the midpoint of the opposite sides.

What if you were told that J , K , and L were the midpoints of the sides of $\triangle FGH$ and that M was the centroid of $\triangle FGH$? Given the length of JK , how could you find the lengths of JM and KM ? After completing this Concept, you'll be able to use the Median Theorem to solve problems like this one.

Watch This

First watch this video.

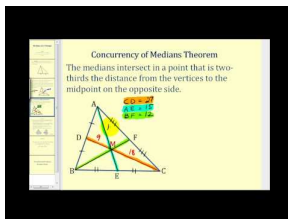

MEDIA

Click image to the left for more content.

James Sousa:Medians of a Triangle

Now watch this video.

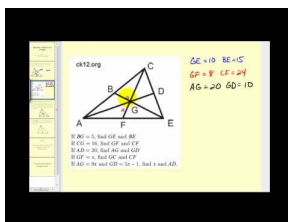

MEDIA

Click image to the left for more content.

James Sousa:Using the Properties of Medians to Solve for Unknown Values

Guidance

In a triangle, the line segment that joins a vertex and the midpoint of the opposite side is called a **median**.

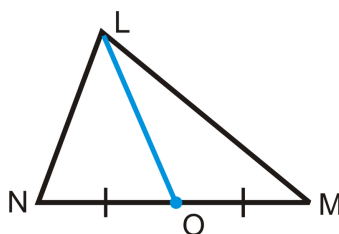

\overline{LO} is the median from L to the midpoint of \overline{NM} .

If you draw all three medians they will intersect at one point called the **centroid**.

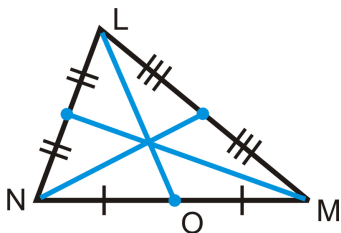

The centroid is the “balancing point” of a triangle. This means that if you were to cut out the triangle, the centroid is its center of gravity so you could balance it there.

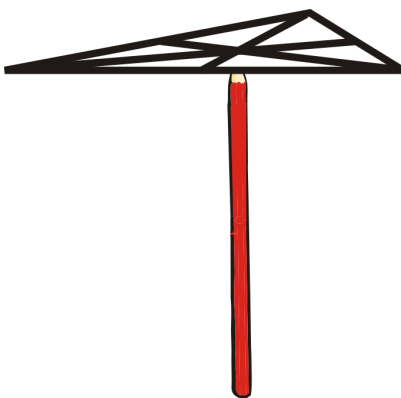

The **Median Theorem** states that the medians of a triangle intersect at a point called the centroid that is two-thirds of the distance from the vertices to the midpoint of the opposite sides.

So if G is the centroid, then:

$$AG = \frac{2}{3}AD, \quad CG = \frac{2}{3}CF, \quad EG = \frac{2}{3}BE$$

$$DG = \frac{1}{3}AD, \quad FG = \frac{1}{3}CF, \quad BG = \frac{1}{3}BE$$

$$\text{And by substitution : } DG = \frac{1}{2}AG, \quad FG = \frac{1}{2}CG, \quad BG = \frac{1}{2}EG$$

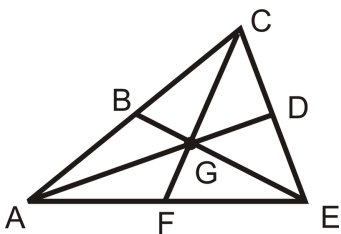

Example A

I , K , and M are midpoints of the sides of $\triangle HJL$.

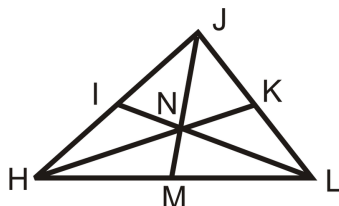

a) If $JM = 18$, find JN and NM .

b) If $HN = 14$, find NK and HK .

To solve, use the Median Theorem.

a) $JN = \frac{2}{3} \cdot 18 = 12$. $NM = JM - JN = 18 - 12$. $NM = 6$.

b) $14 = \frac{2}{3} \cdot HK$

$14 \cdot \frac{3}{2} = HK = 21$. NK is a third of 21, $NK = 7$.

Example B

H is the centroid of $\triangle ABC$ and $DC = 5y - 16$. Find x and y .

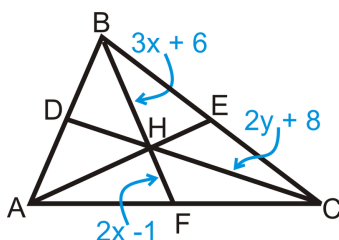

To solve, use the Median Theorem. Set up and solve equations.

$$\frac{1}{2}BH = HF \longrightarrow BH = 2HF$$

$$3x + 6 = 2(2x - 1)$$

$$3x + 6 = 4x - 2$$

$$8 = x$$

$$HC = \frac{2}{3}DC \longrightarrow \frac{3}{2}HC = DC$$

$$\frac{3}{2}(2y + 8) = 5y - 16$$

$$3y + 12 = 5y - 16$$

$$28 = 2y \longrightarrow 14 = y$$

Example C

B , D , and F are the midpoints of each side and G is the centroid. If $BG = 5$, find GE and BE

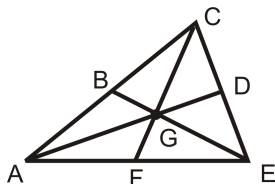

Use the Median Theorem.

$$BG = \frac{1}{3}BE$$

$$5 = \frac{1}{3}BE$$

$$BE = 15$$

Therefore, $GE = 10$.



MEDIA

Click image to the left for more content.

CK-12 Medians

Guided Practice

1. B , D , and F are the midpoints of each side and G is the centroid. If $CG = 16$, find GF and CF

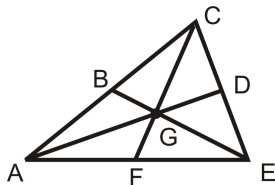

2. True or false: The median bisects the side it intersects.
 3. N and M are the midpoints of sides \overline{XY} and \overline{ZY} .

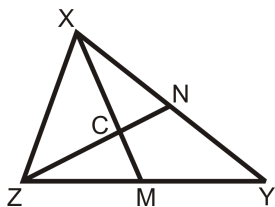

- a. What is point C ?
 b. If $XN = 5$, find XY .
 c. If $ZN = 6x + 15$ and $ZC = 38$, find x and ZN .

Answers

1. Use the Median Theorem.

$$CG = \frac{2}{3}CF$$

$$16 = \frac{2}{3}CF$$

$$CF = 24$$

Therefore, $GF = 8$

2. This statement is true. By definition, a median intersects a side of a triangle at its midpoint. Midpoints divide segments into two equal parts.

3. Use the Median Theorem.

a. C is the centroid.

b. $XN = \frac{1}{2}XY$, so $XY = 10$.

c.

$$ZC = \frac{2}{3}ZN$$

$$38 = \frac{2}{3}(6x + 15)$$

$$57 = 6x + 15$$

$$42 = 6x$$

$$x = 7$$

Substitute 7 for x to find that $ZN = 57$.

Practice

For questions 1-4, B , D , and F are the midpoints of each side and G is the centroid. Find the following lengths.

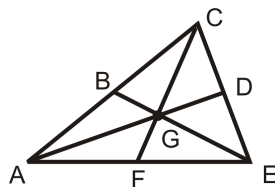

1. If $CG = 16$, find GF and CF
2. If $AD = 30$, find AG and GD
3. If $GF = x$, find GC and CF
4. If $AG = 9x$ and $GD = 5x - 1$, find x and AD .

Multistep Problem Find the equation of a median in the $x - y$ plane.

5. Plot $\triangle ABC$: $A(-6, 4)$, $B(-2, 4)$ and $C(6, -4)$

6. Find the midpoint of \overline{AC} . Label it D .
7. Find the slope of \overline{BD} .
8. Find the equation of \overline{BD} .
9. Plot $\triangle DEF : D(-1, 5), E(0, -1), F(6, 3)$
10. Find the midpoint of \overline{EF} . Label it G .
11. Find the slope of \overline{DG} .
12. Find the equation of \overline{DG} .

Determine whether the following statement is true or false.

13. The centroid is the balancing point of a triangle.

5.5 Altitudes

Here you'll learn the definition of altitude and how to determine where a triangle's altitude will be found.

What if you were given one or more of a triangle's angle measures? How would you determine where the triangle's altitude would be found? After completing this Concept, you'll be able to answer this type of question.

Watch This



MEDIA

Click image to the left for more content.

CK-12 Altitudes

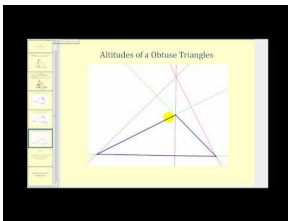

MEDIA

Click image to the left for more content.

James Sousa: Altitudes of a Triangle

Guidance

In a triangle, a line segment from a vertex and perpendicular to the opposite side is called an **altitude**. It is also called the height of a triangle. The red lines below are all altitudes.



When a triangle is a right triangle, the altitude, or height, is the leg. If the triangle is obtuse, then the altitude will be outside of the triangle. If the triangle is acute, then the altitude will be inside the triangle.

Example A

Which line segment is the altitude of $\triangle ABC$?

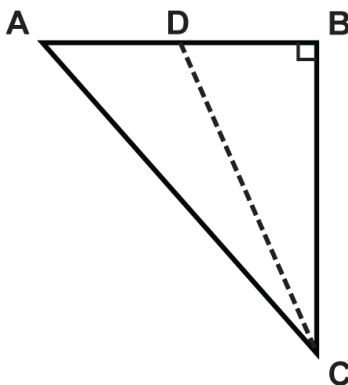

Solution: In a right triangle, the altitude, or the height, is the leg. If we rotate the triangle so that the right angle is in the lower left corner, we see that leg BC is the altitude.

Example B

A triangle has angles that measure 55° , 60° , and 65° . Where will the altitude be found?

Solution: Because all of the angle measures are less than 90° , the triangle is an acute triangle. The altitude of any acute triangle is inside the triangle.

Example C

A triangle has an angle that measures 95° . Where will the altitude be found?

Solution: Because $95^\circ > 90^\circ$, the triangle is an obtuse triangle. The altitude of any obtuse triangle is outside the triangle.



MEDIA

Click image to the left for more content.

[CK-12 Altitudes](#)

Guided Practice

1. True or false: The altitudes of an obtuse triangle are inside the triangle.
2. Draw the altitude for the triangle shown.

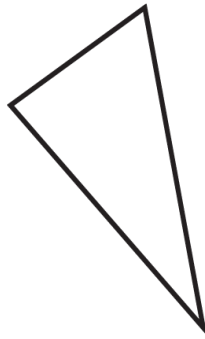

Solution: The triangle is an acute triangle, so the altitude is inside the triangle as shown below so that it is perpendicular to the base.

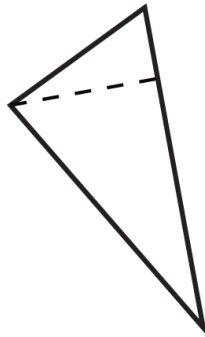

3. Draw the altitude for the triangle shown.

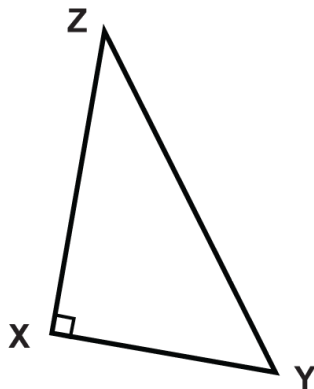

Solution: The triangle is a right triangle, so the altitude is already drawn. The altitude is \overline{XZ} .

Answers

1. Every triangle has three altitudes. For an obtuse triangle, at least one of the altitudes will be outside of the triangle, as shown in the picture at the beginning of this concept.

2.

3.

Practice

Given the following triangles, tell whether the altitude is inside the triangle, outside the triangle, or at the leg of the triangle.

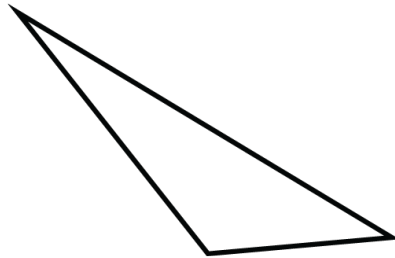

1.

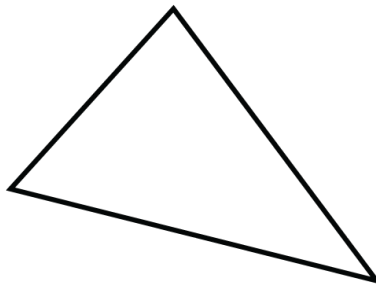

2.

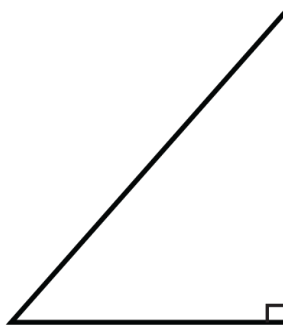

3.

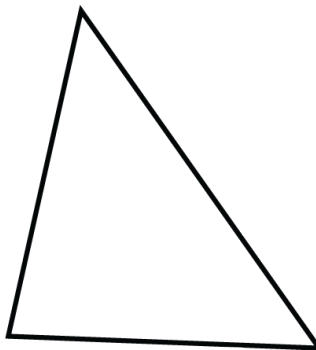

4.

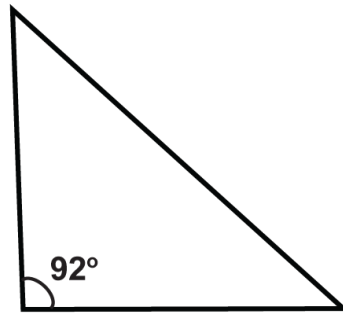

5.

6. $\triangle JKL$ is an equiangular triangle.
7. $\triangle MNO$ is a triangle in which two the angles measure 30° and 60° .
8. $\triangle PQR$ is an isosceles triangle in which two of the angles measure 25° .
9. $\triangle STU$ is an isosceles triangle in which two angles measures 45° .

Given the following triangles, which line segment is the altitude?

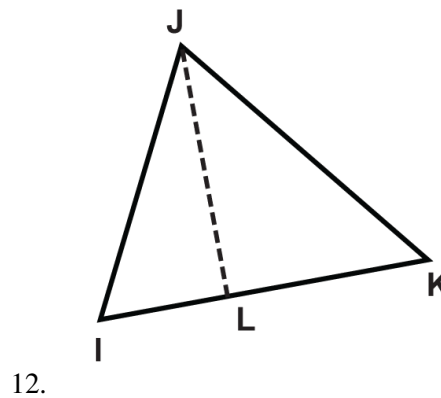
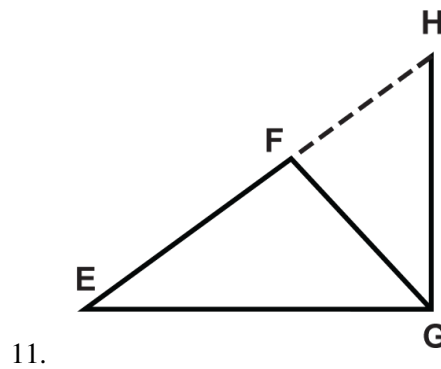
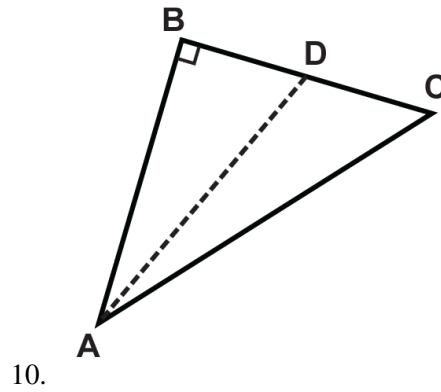

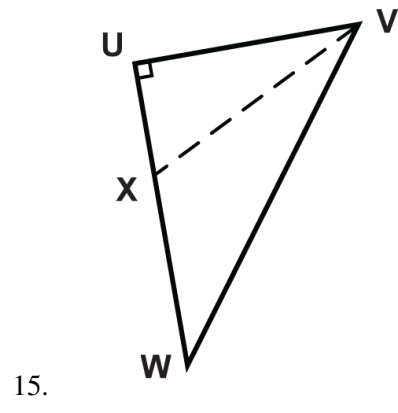
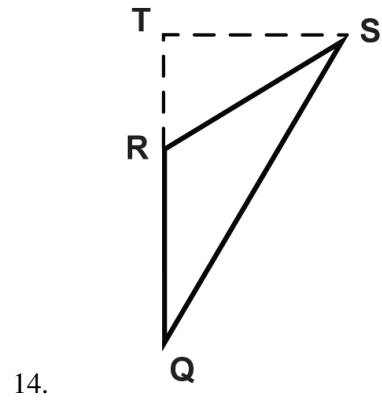
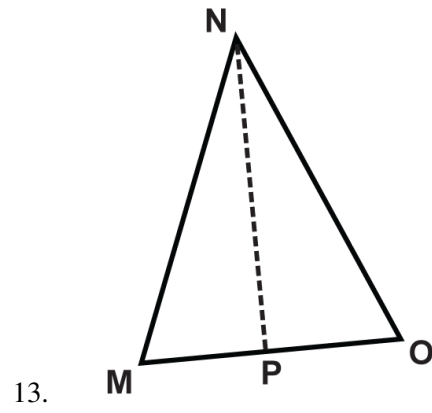

5.6 Comparing Angles and Sides in Triangles

Here you'll learn how to order the angles of a triangle from largest to smallest based on the length of their opposite sides. You'll also learn the SAS and SSS Inequality Theorems.

What if you were told that a triangle has sides that measure 3, 4, and 5? How could you determine which of the triangle's angles is largest? Smallest? After completing this Concept, you'll be able to use triangle theorems to solve problems like this one.

Watch This



MEDIA

Click image to the left for more content.

CK-12 Comparing Angles & Sides in Triangles

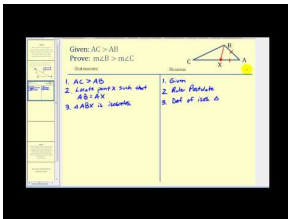

MEDIA

Click image to the left for more content.

James Sousa: Proof that the Angle of a Triangle Opposite the Longest Side is the Largest Angle

Guidance

Look at the triangle below. The sides of the triangle are given. Can you determine which angle is the largest? The largest angle will be opposite 18 because that is the longest side. Similarly, the smallest angle will be opposite 7, which is the shortest side.

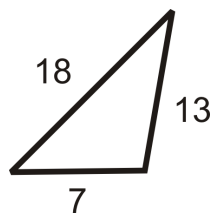

This idea is actually a theorem: If one side of a triangle is longer than another side, then the angle opposite the longer side will be larger than the angle opposite the shorter side.

The converse is also true: If one angle in a triangle is larger than another angle in that triangle, then the side opposite the larger angle will be longer than the side opposite the smaller angle.

We can extend this idea into two theorems that help us compare sides and angles in **two** triangles. If we have two congruent triangles $\triangle ABC$ and $\triangle DEF$, marked below:

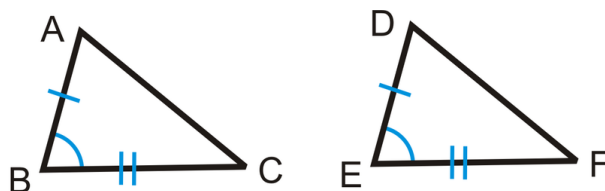

Therefore, if $AB = DE$, $BC = EF$, and $m\angle B = m\angle E$, then $AC = DF$.

Now, let's make $m\angle B > m\angle E$. Would that make $AC > DF$? Yes. This idea is called the **SAS Inequality Theorem**.

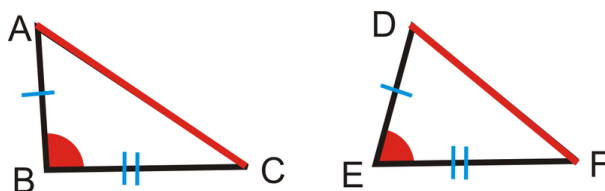

The SAS Inequality Theorem: If two sides of a triangle are congruent to two sides of another triangle, but the included angle of one triangle has greater measure than the included angle of the other triangle, then the third side of the first triangle is longer than the third side of the second triangle.

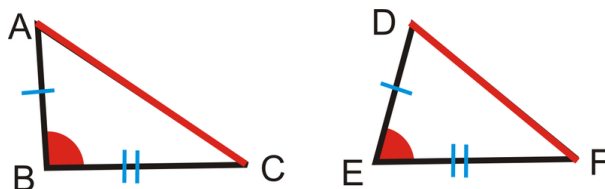

If $\overline{AB} \cong \overline{DE}$, $\overline{BC} \cong \overline{EF}$ and $m\angle B > m\angle E$, then $\overline{AC} > \overline{DF}$.

If we know the third sides as opposed to the angles, the opposite idea is also true and is called the **SSS Inequality Theorem**.

SSS Inequality Theorem: If two sides of a triangle are congruent to two sides of another triangle, but the third side of the first triangle is longer than the third side of the second triangle, then the included angle of the first triangle's two congruent sides is greater in measure than the included angle of the second triangle's two congruent sides.

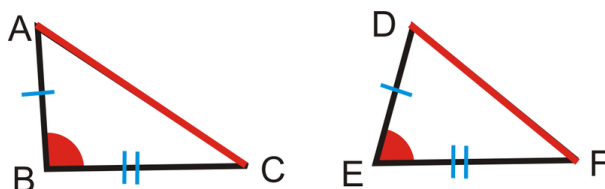

If $\overline{AB} \cong \overline{DE}$, $\overline{BC} \cong \overline{EF}$ and $\overline{AC} > \overline{DF}$, then $m\angle B > m\angle E$.

Example A

List the sides in order, from shortest to longest.

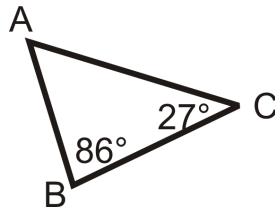

First, find $m\angle A$. From the Triangle Sum Theorem:

$$m\angle A + 86^\circ + 27^\circ = 180^\circ$$

$$m\angle A = 67^\circ$$

86° is the largest angle, so AC is the longest side. The next angle is 67° , so BC would be the next longest side. 27° is the smallest angle, so AB is the shortest side. In order, the answer is: AB, BC, AC .

Example B

List the angles in order, from largest to smallest.

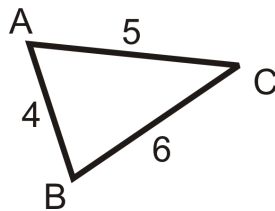

Just like with the sides, the largest angle is opposite the longest side. The longest side is BC , so the largest angle is $\angle A$. Next would be $\angle B$ and then $\angle C$.

Example C

List the sides in order, from least to greatest.

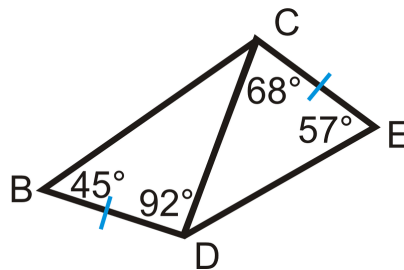

To solve, let's start with $\triangle DCE$. The missing angle is 55° . By the theorem presented in this Concept, the sides, in order from least to greatest are CE, CD , and DE .

For $\triangle BCD$, the missing angle is 43° . Again, by the theorem presented in this Concept, the order of the sides from least to greatest is BD, CD , and BC .

By the SAS Inequality Theorem, we know that $BC > DE$, so the order of all the sides would be: BD, CE, CD, DE, BC .



MEDIA

Click image to the left for more content.

CK-12 Comparing Angles & Sides in Triangles

Guided Practice

1. If \overline{XM} is a median of $\triangle XYZ$ and $XY > XZ$, what can we say about $m\angle 1$ and $m\angle 2$?

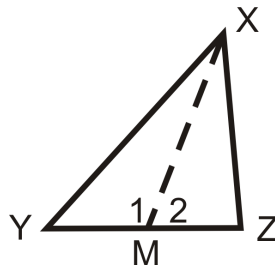

2. List the sides of the two triangles in order, from shortest to longest.

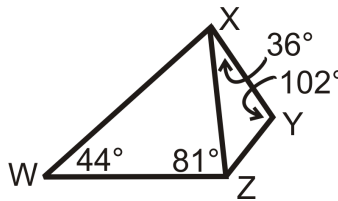

3. Below is isosceles triangle $\triangle ABC$. List everything you can about the sides and angles of the triangle and why.

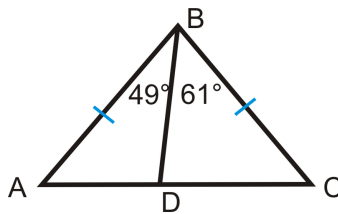

Answers:

1. M is the midpoint of \overline{YZ} , so $YM = MZ$. $MX = MX$ by the Reflexive Property and we know $XY > XZ$.

We can use the SSS Inequality Theorem Converse to say $m\angle 1 > m\angle 2$.

2. There are no congruent sides or angles. Look at each triangle separately.

$\triangle XYZ$: The missing angle is 42° . By the theorem presented in this lesson, the order of the sides from shortest to longest is YZ , XY , and XZ .

$\triangle WXZ$: The missing angle is 55° . The order of the sides from shortest to longest is XZ , WZ , and WX .

Because the longest side in $\triangle XYZ$ is the shortest side in $\triangle WXZ$, we can put all the sides together in one list: YZ , XY , XZ , WZ , WX .

3. $AB = BC$ because it is given.

$m\angle A = m\angle C$ because if sides are equal then their opposite angles must be equal.

$AD < DC$ because $m\angle ABD < m\angle CBD$ and because of the SAS Triangle Inequality Theorem.

Practice

For questions 1-3, list the sides in order from shortest to longest.

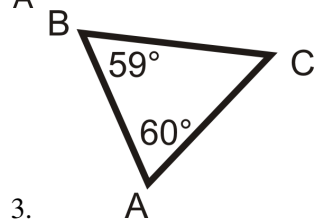
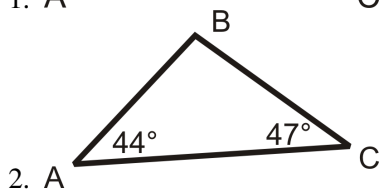
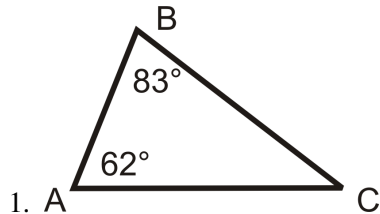

For questions 4-6, list the angles from largest to smallest.

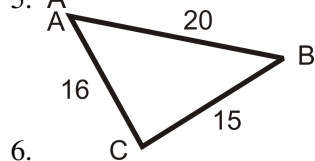
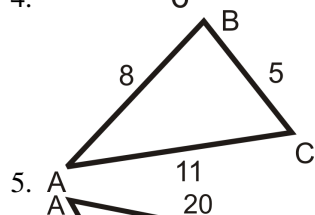
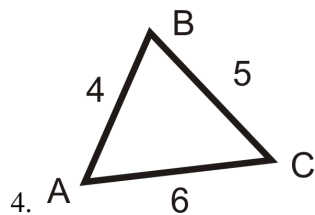

7. Draw a triangle with sides 3 cm, 4 cm, and 5 cm. The angle measures are 90° , 53° , and 37° . Place the angle measures in the appropriate spots.

8. Draw a triangle with angle measures 56° , 54° and the included side is 8 cm. What is the longest side of this triangle?

9. Draw a triangle with sides 6 cm, 7 cm, and 8 cm. The angle measures are 75.5° , 58° , and 46.5° . Place the angle measures in the appropriate spots.

10. What conclusions can you draw about x ?

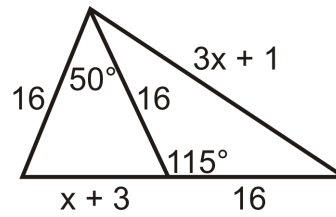

11. Compare $m\angle 1$ and $m\angle 2$.

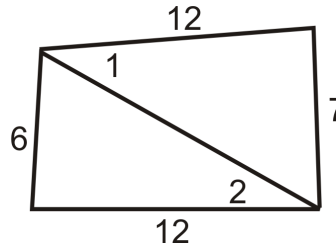

12. List the sides from shortest to longest.

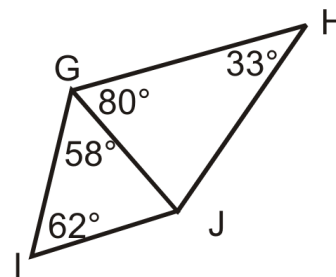

13. Compare $m\angle 1$ and $m\angle 2$. What can you say about $m\angle 3$ and $m\angle 4$?

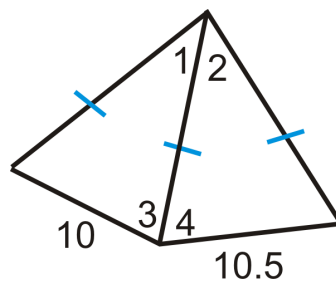

5.7 Triangle Inequality Theorem

Here you'll learn the Triangle Inequality Theorem, which states that to make a triangle, two sides must add up to be greater than the third side.

What if you were given three lengths, like 5, 7 and 10? How could you determine if sides with these lengths form a triangle? After completing this Concept, you'll be able to use the Triangle Inequality Theorem to determine if any three side lengths make a triangle.

Watch This



MEDIA

Click image to the left for more content.

CK-12 Triangle Inequality Theorem

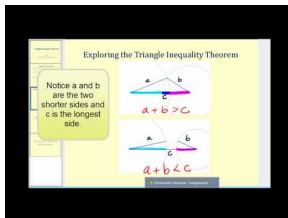

MEDIA

Click image to the left for more content.

James Sousa: Triangle Inequality Theorem

Guidance

Can any three lengths make a triangle? The answer is no. For example, the lengths 1, 2, 3 cannot make a triangle because $1 + 2 = 3$, so they would all lie on the same line. The lengths 4, 5, 10 also cannot make a triangle because $4 + 5 = 9 < 10$. Look at the pictures below:

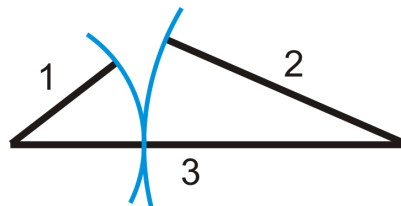

The arcs show that the two sides would never meet to form a triangle.

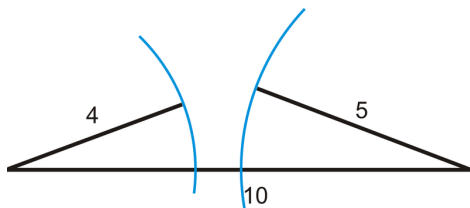

To make a triangle, two sides must add up to be **greater** than the third side. This is called the **Triangle Inequality Theorem**. This means that if you know two sides of a triangle, there are only certain lengths that the third side could be. *If two sides have lengths a and b , then the length of the third side, s , has the range $a - b < s < a + b$.*

Example A

Do the lengths 4, 11, 8 make a triangle?

To solve this problem, check to make sure that the smaller two numbers add up to be greater than the biggest number. $4 + 8 = 12$ and $12 > 11$ so **yes** these lengths make a triangle.

Example B

Find the length of the third side of a triangle if the other two sides are 10 and 6.

The Triangle Inequality Theorem can also help you find the range of the third side. The two given sides are 6 and 10, so the third side, s , can either be the shortest side or the longest side. For example s could be 5 because $6 + 5 > 10$. It could also be 15 because $6 + 10 > 15$. Therefore, the range of values for s is $4 < s < 16$.



Notice the range is no less than 4, and *not equal* to 4. The third side could be 4.1 because $4.1 + 6 > 10$. For the same reason, s cannot be greater than 16, but it could 15.9, $10 + 6 > 15.9$.

Example C

The base of an isosceles triangle has length 24. What can you say about the length of each leg?

To solve this problem, remember that an isosceles triangle has two congruent sides (the legs). We have to make sure that the sum of the lengths of the legs is greater than 24. In other words, if x is the length of a leg:

$$\begin{aligned}x + x &> 24 \\2x &> 24 \\x &> 12\end{aligned}$$

Each leg must have a length greater than 12.



MEDIA

Click image to the left for more content.

CK-12 Triangle Inequality Theorem

Guided Practice

Do the lengths below make a triangle?

1. 4.1, 3.5, 7.5
2. 4, 4, 8
3. 6, 7, 8

Answers:

Use the Triangle Inequality Theorem. Test to see if the smaller two numbers add up to be greater than the largest number.

1. $4.1 + 3.5 > 7.5$. Yes this is a triangle because $7.6 > 7.5$.
2. $4 + 4 = 8$. No this is not a triangle because two lengths *cannot equal* the third.
3. $6 + 7 > 8$. Yes this is a triangle because $13 > 8$.

Practice

Determine if the sets of lengths below can make a triangle. If not, state why.

1. 6, 6, 13
2. 1, 2, 3
3. 7, 8, 10
4. 5, 4, 3
5. 23, 56, 85
6. 30, 40, 50
7. 7, 8, 14
8. 7, 8, 15
9. 7, 8, 14.99

If two lengths of the sides of a triangle are given, determine the range of the length of the third side.

10. 8 and 9
11. 4 and 15
12. 20 and 32
13. 2 and 5
14. 10 and 8
15. x and $2x$
16. The legs of an isosceles triangle have a length of 12 each. What can you say about the length of the base?

5.8 Indirect Proof in Algebra and Geometry

Here you'll learn how to write indirect proofs, or proofs by contradiction, by assuming a hypothesis is false.

What if you wanted to prove a statement was true without a two-column proof? How might you go about doing so? After completing this Concept, you'll be able to indirectly prove a statement by way of contradiction.

Watch This



MEDIA

Click image to the left for more content.

CK-12 Indirect Proof in Algebra and Geometry

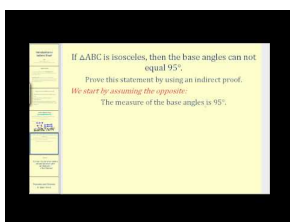

MEDIA

Click image to the left for more content.

James Sousa: Introduction to Indirect Proof

Guidance

Most likely, the first type of formal proof you learned was a direct proof using direct reasoning. Most of the proofs done in geometry are done in the two-column format, which is a direct proof format. Another common type of reasoning is indirect reasoning, which you have likely done outside of math class. Below we will formally learn what an indirect proof is and see some examples in both algebra and geometry.

Indirect Proof or Proof by Contradiction: When the conclusion from a hypothesis is assumed false (or opposite of what it states) and then a contradiction is reached from the given or deduced statements.

In other words, if you are trying to show that something is true, show that if it was not true there would be a contradiction (something else would not make sense).

The steps to follow when proving indirectly are:

- Assume the *opposite* of the conclusion (second half) of the statement.
- Proceed as if this assumption is true to find the *contradiction*.
- Once there is a contradiction, the original statement is true.
- **DO NOT use specific examples.** Use variables so that the contradiction can be generalized.

The easiest way to understand indirect proofs is by example.

Example A (Algebra Example)

If $x = 2$, then $3x - 5 \neq 10$. Prove this statement is true by contradiction.

Remember that in an indirect proof the first thing you do is assume the conclusion of the statement is *false*. In this case, we will assume the *opposite* of "If $x = 2$, then $3x - 5 \neq 10$ ":

If $x = 2$, then $3x - 5 = 10$.

Take this statement as true and solve for x .

$$3x - 5 = 10$$

$$3x = 15$$

$$x = 5$$

But $x = 5$ *contradicts* the given statement that $x = 2$. Hence, our *assumption is incorrect* and $3x - 5 \neq 10$ is *true*.

Example B (Geometry Example)

If $\triangle ABC$ is isosceles, then the measure of the base angles cannot be 92° . Prove this indirectly.

Remember, to start assume the *opposite* of the conclusion.

The measure of the base angles are 92° .

If the base angles are 92° , then they add up to 184° . This *contradicts* the Triangle Sum Theorem that says the three angle measures of all triangles add up to 180° . Therefore, the base angles cannot be 92° .

Example C (Geometry Example)

If $\angle A$ and $\angle B$ are complementary then $\angle A \leq 90^\circ$. Prove this by contradiction.

Assume the *opposite* of the conclusion.

$\angle A > 90^\circ$.

Consider first that the measure of $\angle B$ cannot be negative. So if $\angle A > 90^\circ$ this contradicts the definition of complementary, which says that two angles are complementary if they add up to 90° . Therefore, $\angle A \leq 90^\circ$.



MEDIA

Click image to the left for more content.

CK-12 Indirect Proof in Algebra and Geometry

Guided Practice

1. If n is an integer and n^2 is odd, then n is odd. Prove this is true indirectly.
2. Prove the SSS Inequality Theorem is true by contradiction. (The SSS Inequality Theorem says: "If two sides of a triangle are congruent to two sides of another triangle, but the third side of the first triangle is longer than the third

side of the second triangle, then the included angle of the first triangle's two congruent sides is greater in measure than the included angle of the second triangle's two congruent sides.")

3. If $x = 3$, then $4x + 1 \neq 17$. Prove this statement is true by contradiction.

Answers:

1. First, assume the *opposite* of "n is odd."

n is even.

Now, square n and see what happens.

If n is even, then $n = 2a$, where a is any integer.

$$n^2 = (2a)^2 = 4a^2$$

This means that n^2 is a multiple of 4. No odd number can be divided evenly by an even number, so this *contradicts our assumption* that n is even. Therefore, n must be odd if n^2 is odd.

2. First, assume the opposite of the conclusion.

The included angle of the first triangle is less than or equal to the included angle of the second triangle.

If the included angles are equal then the two triangles would be congruent by SAS and the third sides would be congruent by CPCTC. This contradicts the hypothesis of the original statement "the third side of the first triangle is longer than the third side of the second." Therefore, the included angle of the first triangle must be larger than the included angle of the second.

3. In an indirect proof the first thing you do is assume the conclusion of the statement is *false*. In this case, we will assume the *opposite* of "If $x = 3$, then $4x + 1 \neq 17$ ":

If $x = 3$, then $4x + 1 = 17$

Take this statement as true and solve for x .

$$4x + 1 = 17$$

$$4x = 16$$

$$x = 4$$

$x = 4$ *contradicts* the given statement that $x = 3$. Hence, our *assumption is incorrect* and $4x + 1 \neq 17$ is *true*.

Practice

Prove the following statements true indirectly.

1. If n is an integer and n^2 is even, then n is even.
2. If $m\angle A \neq m\angle B$ in $\triangle ABC$, then $\triangle ABC$ is not equilateral.
3. If $x > 3$, then $x^2 > 9$.
4. The base angles of an isosceles triangle are congruent.
5. If x is even and y is odd, then $x + y$ is odd.
6. In $\triangle ABE$, if $\angle A$ is a right angle, then $\angle B$ cannot be obtuse.
7. If A , B , and C are collinear, then $AB + BC = AC$ (Segment Addition Postulate).
8. If $\triangle ABC$ is equilateral, then the measure of the base angles cannot be 72° .
9. If $x = 11$ then $2x - 3 \neq 21$.
10. If $\triangle ABC$ is a right triangle, then it cannot have side lengths 3, 4, and 6.

Summary

This chapter begins with an introduction to the Midsegment Theorem. The definition of a perpendicular bisector is presented and the Perpendicular Bisector Theorem and its converse are explored. Now that the bisectors of segments have been discussed, the definition of an angle bisector is next and the Angle Bisector Theorem and its converse are presented. The properties of medians and altitudes of triangles are discussed in detail. The entire chapter builds to a discovery of the relationships between the angles and sides in triangles as a foundation for the Triangle Inequality Theorem. The chapter ends with a presentation of indirect proofs.

CHAPTER 6

Polygons and Quadrilaterals

Chapter Outline

- 6.1 INTERIOR ANGLES IN CONVEX POLYGONS**
 - 6.2 EXTERIOR ANGLES IN CONVEX POLYGONS**
 - 6.3 PARALLELOGRAMS**
 - 6.4 QUADRILATERALS THAT ARE PARALLELOGRAMS**
 - 6.5 PARALLELOGRAM CLASSIFICATION**
 - 6.6 TRAPEZOIDS**
 - 6.7 KITES**
 - 6.8 QUADRILATERAL CLASSIFICATION**
-

Introduction

This chapter starts with the properties of polygons and narrows to focus on quadrilaterals. We will study several different types of quadrilaterals: parallelograms, rhombi, rectangles, squares, kites and trapezoids. Then, we will prove that different types of quadrilaterals are parallelograms.

6.1 Interior Angles in Convex Polygons

Here you'll learn how to find the measure of an interior angle of a convex polygon based on the number of sides the polygon has.

What if you were given an equiangular seven-sided convex polygon? How could you determine the measure of its interior angles? After completing this Concept, you'll be able to use the Polygon Sum Formula to solve problems like this one.

Watch This



MEDIA

Click image to the left for more content.

CK-12 Interior Angles in Convex Polygons

Watch the first half of this video.

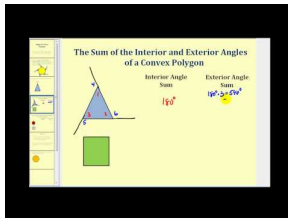

MEDIA

Click image to the left for more content.

James Sousa: Angles of Convex Polygons

Guidance

The **interior angle** of a polygon is one of the angles on the inside, as shown in the picture below. A polygon has the same number of interior angles as it does sides.

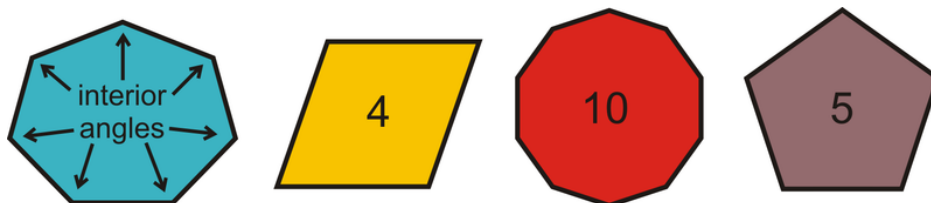

The sum of the interior angles in a polygon depends on the number of sides it has. The **Polygon Sum Formula** states that for any n -gon, the interior angles add up to $(n - 2) \times 180^\circ$.

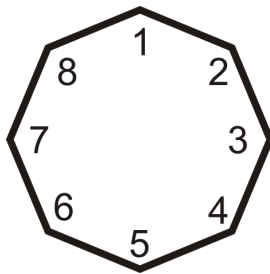

$$\begin{aligned} \rightarrow n &= 8 \\ (8 - 2) \times 180^\circ & \\ 6 \times 180^\circ & \\ 1080^\circ & \end{aligned}$$

Once you know the sum of the interior angles in a polygon it is easy to find the measure of ONE interior angle if the polygon is **regular**: all sides are congruent and all angles are congruent. Just divide the sum of the angles by the number of sides.

Regular Polygon Interior Angle Formula: For any equiangular n -gon, the measure of each angle is $\frac{(n-2) \times 180^\circ}{n}$.

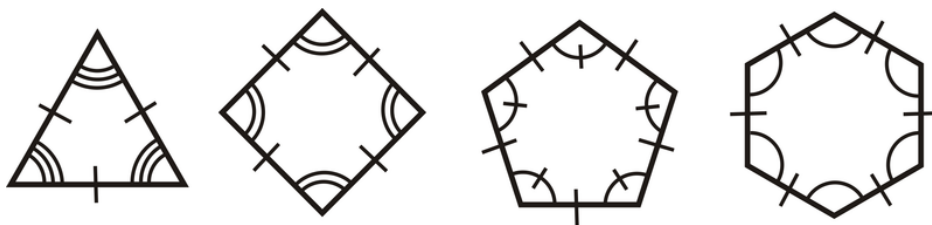

In the picture below, if all eight angles are congruent then each angle is $\frac{(8-2) \times 180^\circ}{8} = \frac{6 \times 180^\circ}{8} = \frac{1080^\circ}{8} = 135^\circ$.

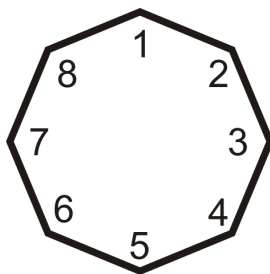

Example A

The interior angles of a polygon add up to 1980° . How many sides does it have?

Use the Polygon Sum Formula and solve for n .

$$\begin{aligned} (n - 2) \times 180^\circ &= 1980^\circ \\ 180^\circ n - 360^\circ &= 1980^\circ \\ 180^\circ n &= 2340^\circ \\ n &= 13 \end{aligned}$$

The polygon has 13 sides.

Example B

How many degrees does *each angle* in an equiangular nonagon have?

First we need to find the sum of the interior angles; set $n = 9$.

$$(9 - 2) \times 180^\circ = 7 \times 180^\circ = 1260^\circ$$

“Equiangular” tells us every angle is equal. So, each angle is $\frac{1260^\circ}{9} = 140^\circ$.

Example C

An interior angle in a regular polygon is 135° . How many sides does this polygon have?

Here, we will set the Regular Polygon Interior Angle Formula equal to 135° and solve for n .

$$\begin{aligned} \frac{(n - 2) \times 180^\circ}{n} &= 135^\circ \\ 180^\circ n - 360^\circ &= 135^\circ n \\ -360^\circ &= -45^\circ n \\ n &= 8 \end{aligned}$$

The polygon is an octagon.



MEDIA

Click image to the left for more content.

CK-12 Interior Angles in Convex Polygons

Guided Practice

1. Find the measure of x .

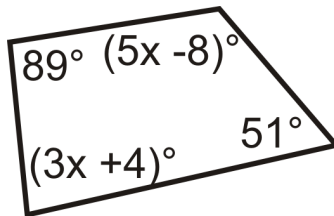

2. The interior angles of a pentagon are x° , x° , $2x^\circ$, $2x^\circ$, and $2x^\circ$. What is x ?
3. What is the sum of the interior angles in a 100-gon?

Answers:

1. From the Polygon Sum Formula we know that a quadrilateral has interior angles that sum to $(4 - 2) \times 180^\circ = 360^\circ$.

Write an equation and solve for x .

$$\begin{aligned} 89^\circ + (5x - 8)^\circ + (3x + 4)^\circ + 51^\circ &= 360^\circ \\ 8x &= 224 \\ x &= 28 \end{aligned}$$

2. From the Polygon Sum Formula we know that a pentagon has interior angles that sum to $(5 - 2) \times 180^\circ = 540^\circ$.

Write an equation and solve for x .

$$\begin{aligned} x^\circ + x^\circ + 2x^\circ + 2x^\circ + 2x^\circ &= 540^\circ \\ 8x &= 540 \\ x &= 67.5 \end{aligned}$$

3. Use the Polygon Sum Formula. $(100 - 2) \times 180^\circ = 17,640^\circ$.

Practice

- Fill in the table.

TABLE 6.1:

# of sides	Sum of the Interior Angles	Measure of Each Interior Angle in a Regular n -gon
3		60°
4	360°	
5	540°	108°
6		120°
7		
8		
9		
10		
11		
12		

- What is the sum of the angles in a 15-gon?
- What is the sum of the angles in a 23-gon?
- The sum of the interior angles of a polygon is 4320° . How many sides does the polygon have?
- The sum of the interior angles of a polygon is 3240° . How many sides does the polygon have?
- What is the measure of each angle in a regular 16-gon?
- What is the measure of each angle in an equiangular 24-gon?
- Each interior angle in a regular polygon is 156° . How many sides does it have?
- Each interior angle in an equiangular polygon is 90° . How many sides does it have?

For questions 10-18, find the value of the missing variable(s).

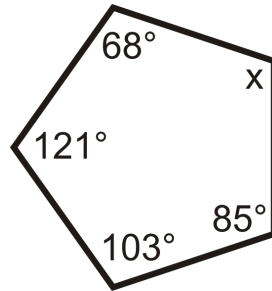

10.

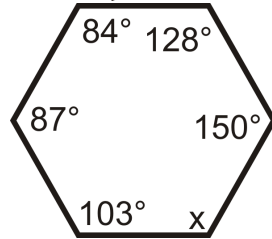

11.

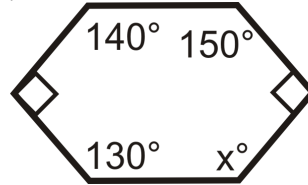

12.

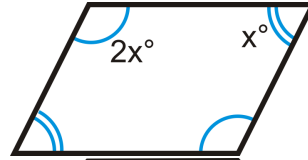

13.

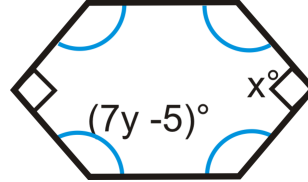

14.

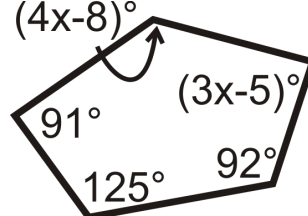

15.

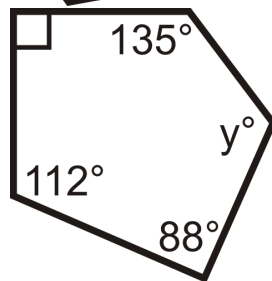

16.

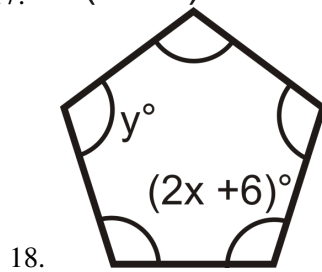
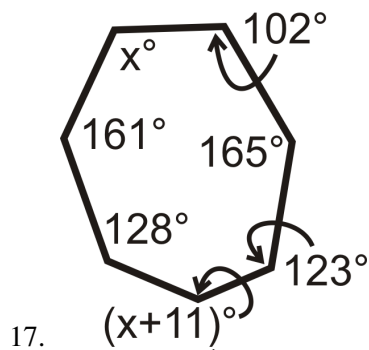

19. The interior angles of a hexagon are x° , $(x+1)^\circ$, $(x+2)^\circ$, $(x+3)^\circ$, $(x+4)^\circ$, and $(x+5)^\circ$. What is x ?

6.2 Exterior Angles in Convex Polygons

Here you'll learn the Exterior Angle Sum Theorem that states that the exterior angles of a polygon always add up to 360° .

What if you were given a seven-sided regular polygon? How could you determine the measure of each of its exterior angles? After completing this Concept, you'll be able to use the Exterior Angle Sum Theorem to solve problems like this one.

Watch This



MEDIA

Click image to the left for more content.

CK-12 Exterior Angles in Convex Polygons

Watch the second half of this video.

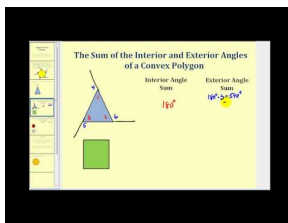

MEDIA

Click image to the left for more content.

James Sousa: Angles of Convex Polygons

Guidance

An exterior angle is an angle that is formed by extending a side of the polygon.

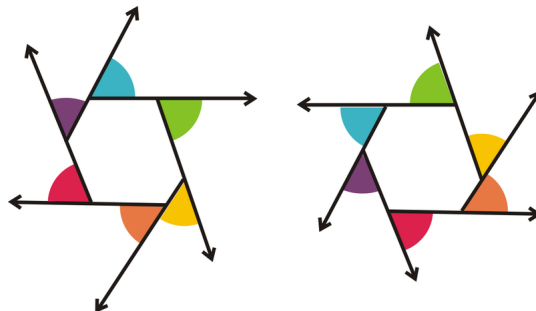

As you can see, there are two sets of exterior angles for any vertex on a polygon, one going around clockwise (1^{st} hexagon), and the other going around counter-clockwise (2^{nd} hexagon). The angles with the same colors are vertical and congruent.

The **Exterior Angle Sum Theorem** states that the sum of the exterior angles of ANY convex polygon is 360° . If the polygon is regular with n sides, this means that each exterior angle is $\frac{360^\circ}{n}$.

Example A

What is y ?

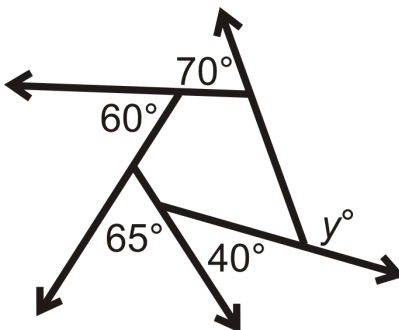

y is an exterior angle and all the given angles add up to 360° . Set up an equation.

$$70^\circ + 60^\circ + 65^\circ + 40^\circ + y = 360^\circ$$

$$y = 125^\circ$$

Example B

What is the measure of each exterior angle of a regular heptagon?

Because the polygon is regular, the interior angles are equal. It also means the exterior angles are equal. $\frac{360^\circ}{7} \approx 51.43^\circ$

Example C

What is the sum of the exterior angles in a regular 15-gon?

The sum of the exterior angles in any convex polygon, including a regular 15-gon, is 360° .



MEDIA

Click image to the left for more content.

[CK-12 Exterior Angles in Convex Polygons](#)

Guided Practice

Find the measure of each exterior angle for each regular polygon below:

- 12-gon

2. 100-gon

3. 36-gon

Answers:For each, divide 360° by the given number of sides.1. 30° 2. 3.6° 3. 10° **Practice**

1. What is the measure of each exterior angle of a regular decagon?
2. What is the measure of each exterior angle of a regular 30-gon?
3. What is the sum of the exterior angles of a regular 27-gon?

Find the measure of the missing variables:

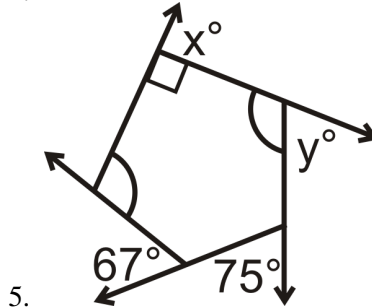
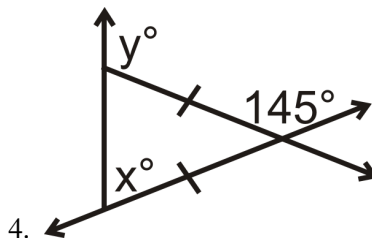

6. The exterior angles of a quadrilateral are
- x°
- ,
- $2x^\circ$
- ,
- $3x^\circ$
- , and
- $4x^\circ$
- . What is
- x
- ?

Find the measure of each exterior angle for each regular polygon below:

7. octagon
8. nonagon
9. triangle
10. pentagon

6.3 Parallelograms

Here you'll learn what a parallelogram is and how apply theorems about its sides, angles, and diagonals to solve for unknown values.

What if you were told that $FGHI$ is a parallelogram and you are given the length of FG and the measure of $\angle F$? What can you determine about HI , $\angle H$, $\angle G$, and $\angle I$? After completing this Concept, you'll be able to apply parallelogram theorems to answer such questions.

Watch This



MEDIA

Click image to the left for more content.

CK-12 Parallelograms

Guidance

A **parallelogram** is a quadrilateral with two pairs of parallel sides.

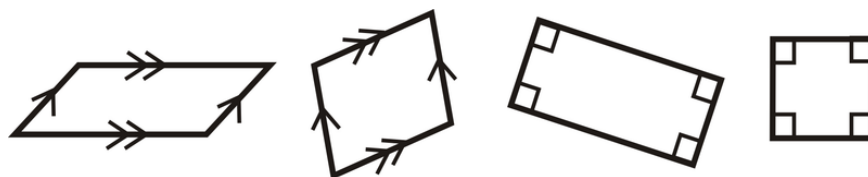

Notice that each pair of sides is marked parallel (for the last two shapes, remember that when two lines are perpendicular to the same line then they are parallel). Parallelograms have a lot of interesting properties. (You can explore the properties of a parallelogram at: <http://www.mathwarehouse.com/geometry/quadrilaterals/parallelograms/interactive-parallelogram.php>)

Facts about Parallelograms

1) **Opposite Sides Theorem:** If a quadrilateral is a parallelogram, then both pairs of opposite sides are congruent.

If

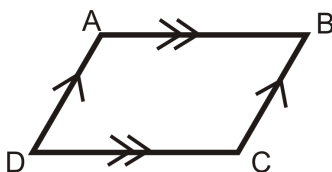

then

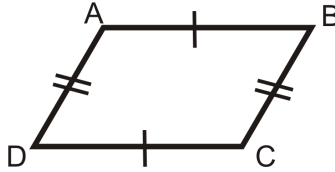

2) **Opposite Angles Theorem:** If a quadrilateral is a parallelogram, then both pairs of opposite angles are congruent.

If

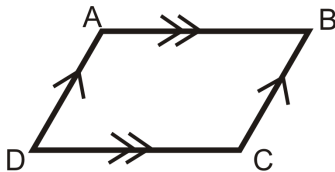

then

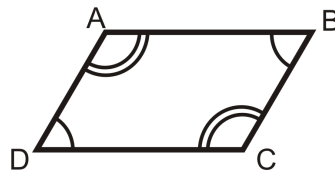

3) **Consecutive Angles Theorem:** If a quadrilateral is a parallelogram, then all pairs of consecutive angles are supplementary.

If

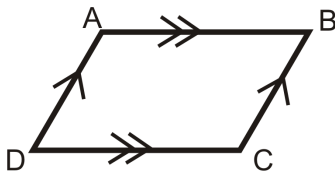

then

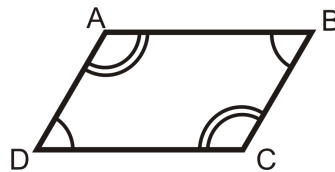

$$m\angle A + m\angle D = 180^\circ$$

$$m\angle A + m\angle B = 180^\circ$$

$$m\angle B + m\angle C = 180^\circ$$

$$m\angle C + m\angle D = 180^\circ$$

4) **Parallelogram Diagonals Theorem:** If a quadrilateral is a parallelogram, then the diagonals bisect each other.

If

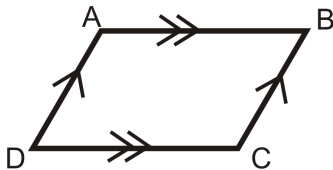

then

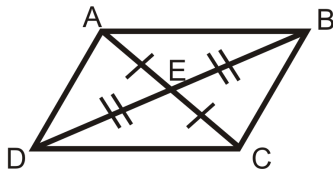

Example A

$ABCD$ is a parallelogram. If $m\angle A = 56^\circ$, find the measure of the other angles.

First draw a picture. When labeling the vertices, the letters are listed, in order.

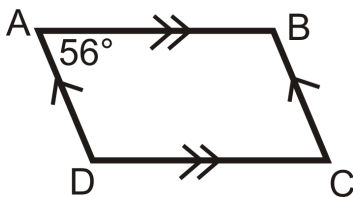

If $m\angle A = 56^\circ$, then $m\angle C = 56^\circ$ by the Opposite Angles Theorem.

$$m\angle A + m\angle B = 180^\circ \quad \text{by the Consecutive Angles Theorem.}$$

$$56^\circ + m\angle B = 180^\circ$$

$$m\angle B = 124^\circ \quad m\angle D = 124^\circ \quad \text{because it is an opposite angle to } \angle B.$$

Example B

Find the values of x and y .

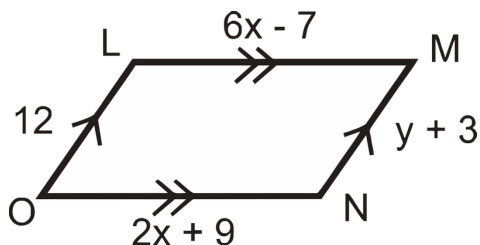

Remember that opposite sides of a parallelogram are congruent. Set up equations and solve.

$$6x - 7 = 2x + 9$$

$$4x = 16$$

$$x = 4$$

$$y + 3 = 12$$

$$y = 9$$

Example C

Prove the Opposite Sides Theorem.

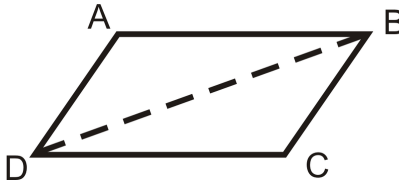

Given: $ABCD$ is a parallelogram with diagonal \overline{BD}

Prove: $\overline{AB} \cong \overline{DC}, \overline{AD} \cong \overline{BC}$

TABLE 6.2:

Statement

1. $ABCD$ is a parallelogram with diagonal \overline{BD}
2. $\overline{AB} \parallel \overline{DC}, \overline{AD} \parallel \overline{BC}$
3. $\angle ABD \cong \angle BDC, \angle ADB \cong \angle DBC$
4. $\overline{DB} \cong \overline{DB}$
5. $\triangle ABD \cong \triangle CDB$
6. $\overline{AB} \cong \overline{DC}, \overline{AD} \cong \overline{BC}$

Reason

1. Given
2. Definition of a parallelogram
3. Alternate Interior Angles Theorem
4. Reflexive PoC
5. ASA
6. CPCTC

The proof of the Opposite Angles Theorem is almost identical. You will try this proof in the problem set.

**MEDIA**

Click image to the left for more content.

[CK-12 Parallelograms](#)

Guided Practice

1. Show that the diagonals of $FGHJ$ bisect each other.

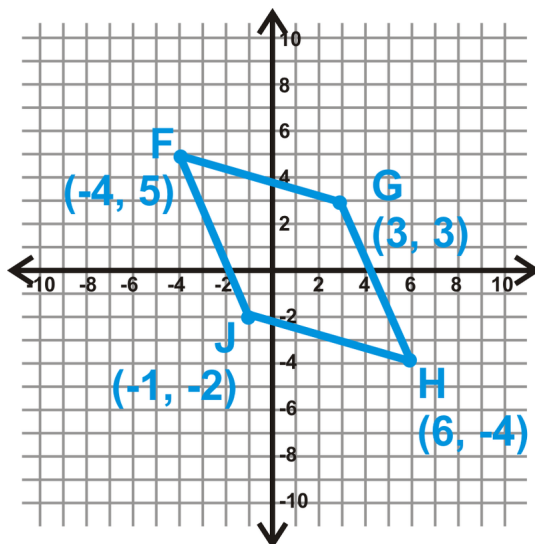

2. SAND is a parallelogram, $SY = 4x - 11$ and $YN = x + 10$. Solve for x .

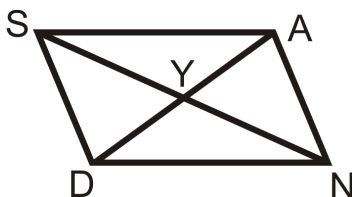

3. Find the measures of a and b in the parallelogram below:

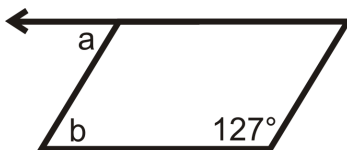

Answers:

1. Find the midpoint of each diagonal.

$$\text{Midpoint of } \overline{FH} : \left(\frac{-4+6}{2}, \frac{5-4}{2} \right) = (1, 0.5)$$

$$\text{Midpoint of } \overline{GJ} : \left(\frac{3-1}{2}, \frac{3-2}{2} \right) = (1, 0.5)$$

Because they are the same point, the diagonals intersect at each other's midpoint. This means they bisect each other.

2. Because this is a parallelogram, the diagonals bisect each other and $SY \cong YN$.

$$\begin{aligned} SY &= YN \\ 4x - 11 &= x + 10 \\ 3x &= 21 \\ x &= 7 \end{aligned}$$

3. Consecutive angles are supplementary so $127^\circ + m\angle b = 180^\circ$ which means that $m\angle b = 53^\circ$. a and b are alternate interior angles and since the lines are parallel (since its a parallelogram), that means that $m\angle a = m\angle b = 53^\circ$.

Practice

$ABCD$ is a parallelogram. Fill in the blanks below.

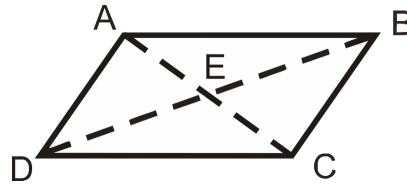

- If $AB = 6$, then $CD =$ _____.
- If $AE = 4$, then $AC =$ _____.
- If $m\angle ADC = 80^\circ$, $m\angle DAB =$ _____.
- If $m\angle BAC = 45^\circ$, $m\angle ACD =$ _____.
- If $m\angle CBD = 62^\circ$, $m\angle ADB =$ _____.
- If $DB = 16$, then $DE =$ _____.
- If $m\angle B = 72^\circ$ in parallelogram $ABCD$, find the other three angles.
- If $m\angle S = 143^\circ$ in parallelogram $PQRS$, find the other three angles.
- If $\overline{AB} \perp \overline{BC}$ in parallelogram $ABCD$, find the measure of all four angles.
- If $m\angle F = x^\circ$ in parallelogram $EFGH$, find the other three angles.

For questions 11-18, find the values of the variable(s). All the figures below are parallelograms.

-
-
-
-
-

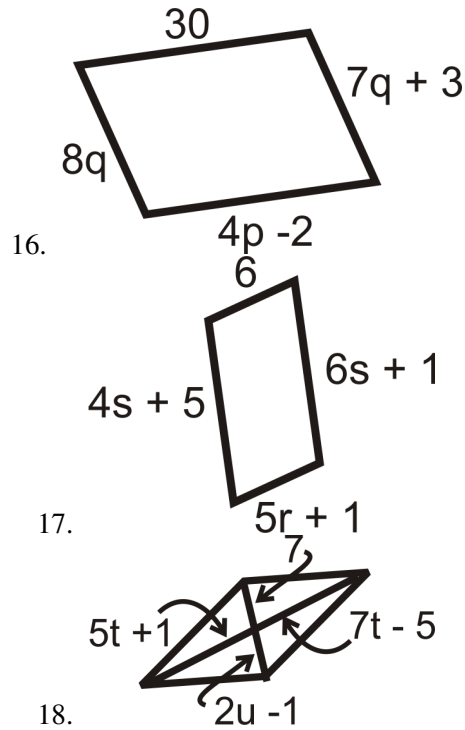

Use the parallelogram *WAVE* to find:

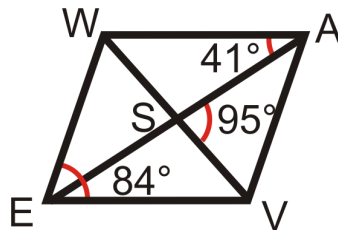

- 19. $m\angle AWE$
- 20. $m\angle ESV$
- 21. $m\angle WEA$
- 22. $m\angle AVW$

Find the point of intersection of the diagonals to see if *EFGH* is a parallelogram.

- 23. $E(-1, 3), F(3, 4), G(5, -1), H(1, -2)$
- 24. $E(3, -2), F(7, 0), G(9, -4), H(5, -4)$
- 25. $E(-6, 3), F(2, 5), G(6, -3), H(-4, -5)$
- 26. $E(-2, -2), F(-4, -6), G(-6, -4), H(-4, 0)$

Fill in the blanks in the proofs below.

27. **Opposite Angles Theorem**

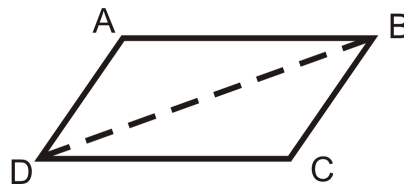

Given: $ABCD$ is a parallelogram with diagonal \overline{BD}

Prove: $\angle A \cong \angle C$

TABLE 6.3:

<i>Statement</i>	<i>Reason</i>
1.	1. Given
2. $\overline{AB} \parallel \overline{DC}, \overline{AD} \parallel \overline{BC}$	2.
3.	3. Alternate Interior Angles Theorem
4.	4. Reflexive PoC
5. $\triangle ABD \cong \triangle CDB$	5.
6. $\angle A \cong \angle C$	6.

28. Parallelogram Diagonals Theorem

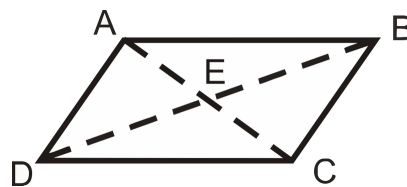

Given: $ABCD$ is a parallelogram with diagonals \overline{BD} and \overline{AC}

Prove: $\overline{AE} \cong \overline{EC}, \overline{DE} \cong \overline{EB}$

TABLE 6.4:

<i>Statement</i>	<i>Reason</i>
1.	1.
2.	2. Definition of a parallelogram
3.	3. Alternate Interior Angles Theorem
4. $\overline{AB} \cong \overline{DC}$	4.
5.	5.
6. $\overline{AE} \cong \overline{EC}, \overline{DE} \cong \overline{EB}$	6.

29. Find x, y° , and z° . (The two quadrilaterals with the same side are parallelograms.)

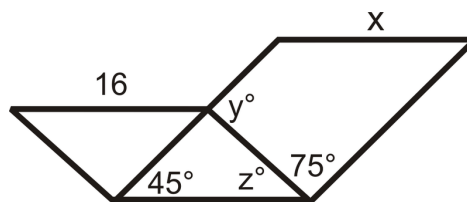

6.4 Quadrilaterals that are Parallelograms

Here you'll learn how to apply various quadrilateral theorems to prove that a quadrilateral is a parallelogram.

What if you were given four pairs of coordinates that form a quadrilateral? How could you determine if that quadrilateral is a parallelogram? After completing this Concept, you'll be able to use the Parallel Congruent Sides Theorem and other quadrilateral theorems to solve problems like this one.

Watch This



MEDIA

Click image to the left for more content.

CK-12 Proving a Quadrilateral is a Parallelogram

Guidance

Recall that a parallelogram is a quadrilateral with two pairs of parallel sides. Even if a quadrilateral is not marked with having two pairs of sides, it still might be a parallelogram. The following is a list of theorems that will help you decide if a quadrilateral is a parallelogram or not.

1) **Opposite Sides Theorem Converse:** If both pairs of opposite sides of a quadrilateral are congruent, then the figure is a parallelogram.

If

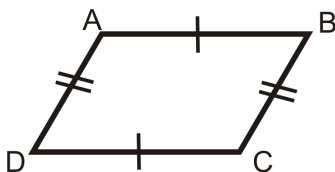

then

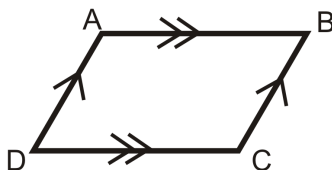

2) **Opposite Angles Theorem Converse:** If both pairs of opposite angles of a quadrilateral are congruent, then the figure is a parallelogram.

If

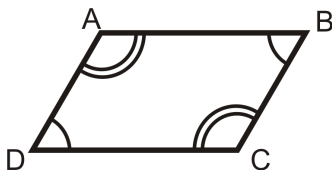

then

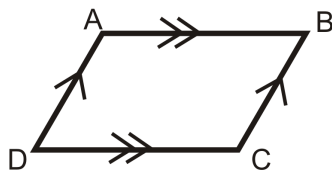

3) **Parallelogram Diagonals Theorem Converse:** If the diagonals of a quadrilateral bisect each other, then the figure is a parallelogram.

If

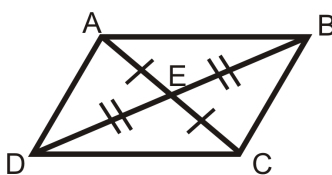

then

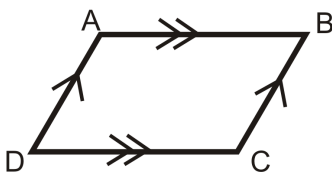

4) **Parallel Congruent Sides Theorem:** If a quadrilateral has one set of parallel lines that are also congruent, then it is a parallelogram.

If

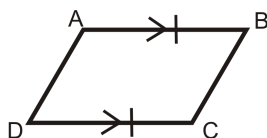

then

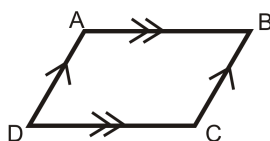

You can use any of the above theorems to help show that a quadrilateral is a parallelogram. If you are working in the $x - y$ plane, you might need to know the formulas shown below to help you use the theorems.

- The Slope Formula, $\frac{y_2 - y_1}{x_2 - x_1}$. (Remember that if slopes are the same then lines are parallel).
- The Distance Formula, $\sqrt{(x_2 - x_1)^2 + (y_2 - y_1)^2}$. (This will help you to show that two sides are congruent).
- The Midpoint Formula, $(\frac{x_1 + x_2}{2}, \frac{y_1 + y_2}{2})$. (If the midpoints of the diagonals are the same then the diagonals bisect each other).

Example A

Prove the Opposite Sides Theorem Converse.

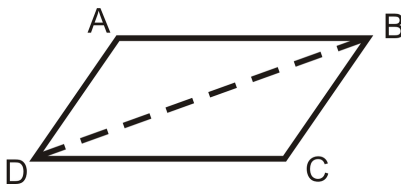

Given: $\overline{AB} \cong \overline{DC}, \overline{AD} \cong \overline{BC}$

Prove: $ABCD$ is a parallelogram

TABLE 6.5:

Statement

1. $\overline{AB} \cong \overline{DC}, \overline{AD} \cong \overline{BC}$
2. $\overline{DB} \cong \overline{DB}$
3. $\triangle ABD \cong \triangle CDB$
4. $\angle ABD \cong \angle BDC, \angle ADB \cong \angle DBC$
5. $\overline{AB} \parallel \overline{DC}, \overline{AD} \parallel \overline{BC}$
6. $ABCD$ is a parallelogram

Reason

1. Given
2. Reflexive PoC
3. SSS
4. CPCTC
5. Alternate Interior Angles Converse
6. Definition of a parallelogram

Example B

Is quadrilateral $EFGH$ a parallelogram? How do you know?

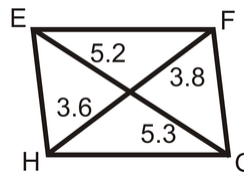
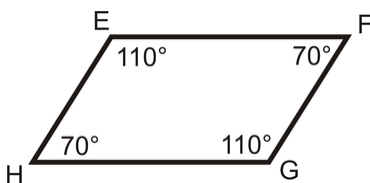

- a) By the Opposite Angles Theorem Converse, $EFGH$ is a parallelogram.
- b) $EFGH$ is not a parallelogram because the diagonals do not bisect each other.

Example C

Is the quadrilateral $ABCD$ a parallelogram?

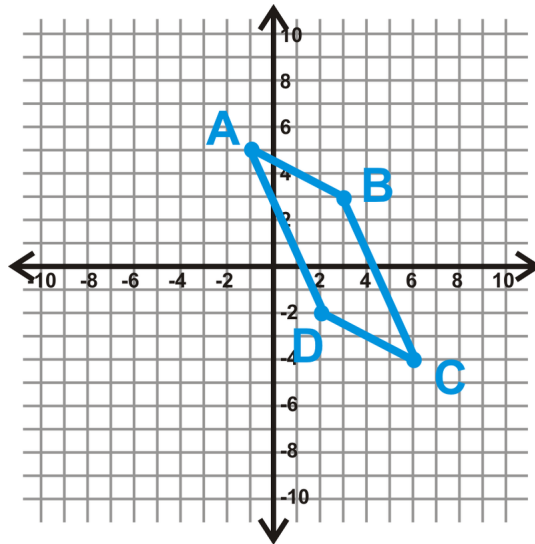

Let's use the Parallel Congruent Sides Theorem to see if $ABCD$ is a parallelogram. First, find the length of AB and CD using the distance formula.

$$\begin{aligned} AB &= \sqrt{(-1-3)^2 + (5-3)^2} \\ &= \sqrt{(-4)^2 + 2^2} \\ &= \sqrt{16+4} \\ &= \sqrt{20} \end{aligned}$$

$$\begin{aligned} CD &= \sqrt{(2-6)^2 + (-2+4)^2} \\ &= \sqrt{(-4)^2 + 2^2} \\ &= \sqrt{16+4} \\ &= \sqrt{20} \end{aligned}$$

Next find the slopes to check if the lines are parallel.

$$\text{Slope } AB = \frac{5-3}{-1-3} = \frac{2}{-4} = -\frac{1}{2} \quad \text{Slope } CD = \frac{-2+4}{2-6} = \frac{2}{-4} = -\frac{1}{2}$$

$AB = CD$ and the slopes are the same (implying that the lines are parallel), so $ABCD$ is a parallelogram.



MEDIA

Click image to the left for more content.

CK-12 Proving a Quadrilateral is a Parallelogram

Guided Practice

1. Prove the Parallel Congruent Sides Theorem.

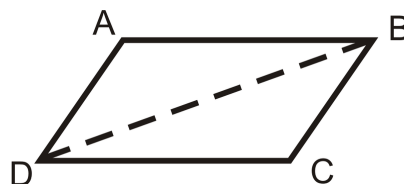

Given: $\overline{AB} \parallel \overline{DC}$, and $\overline{AB} \cong \overline{DC}$

Prove: $ABCD$ is a parallelogram

2. What value of x would make $ABCD$ a parallelogram?

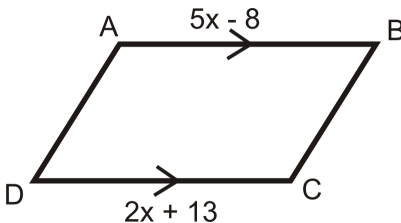

3. Is the quadrilateral $RSTU$ a parallelogram?

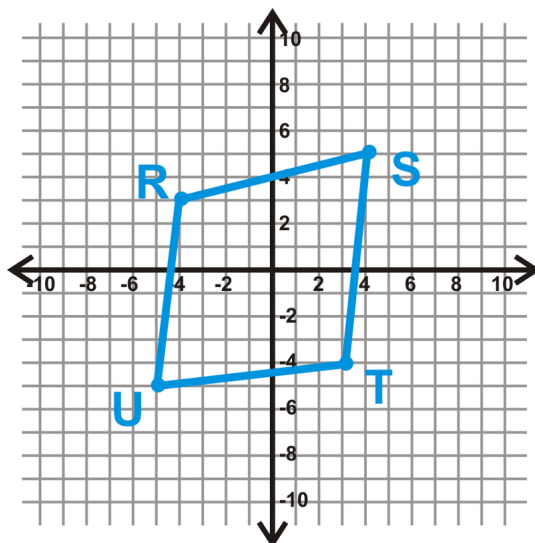

Answers:

1.

TABLE 6.6:

Statement

1. $\overline{AB} \parallel \overline{DC}$, and $\overline{AB} \cong \overline{DC}$
2. $\angle ABD \cong \angle BDC$
3. $\overline{DB} \cong \overline{DB}$
4. $\triangle ABD \cong \triangle CDB$
5. $\overline{AD} \cong \overline{BC}$
6. $ABCD$ is a parallelogram

Reason

1. Given
2. Alternate Interior Angles
3. Reflexive PoC
4. SAS
5. CPCTC
6. Opposite Sides Converse

2. $\overline{AB} \parallel \overline{DC}$. By the Parallel Congruent Sides Theorem, $ABCD$ would be a parallelogram if $AB = DC$.

$$5x - 8 = 2x + 13$$

$$3x = 21$$

$$x = 7$$

3. Let's use the Parallelogram Diagonals Converse to see if $RSTU$ is a parallelogram. Find the midpoint of each diagonal.

$$\text{Midpoint of } RT = \left(\frac{-4+3}{2}, \frac{3-4}{2} \right) = (-0.5, -0.5)$$

$$\text{Midpoint of } SU = \left(\frac{4-5}{2}, \frac{5-5}{2} \right) = (-0.5, 0)$$

$RSTU$ is not a parallelogram because the midpoints are not the same.

Practice

For questions 1-12, determine if the quadrilaterals are parallelograms.

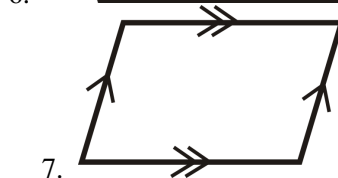
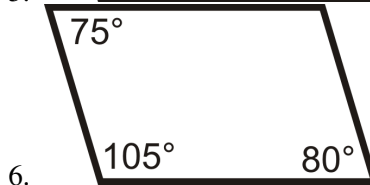
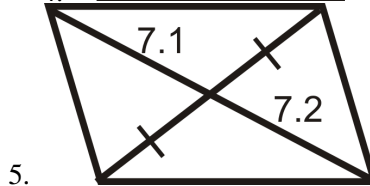
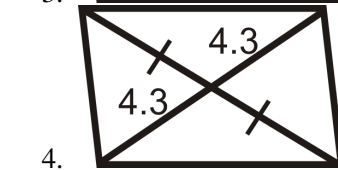
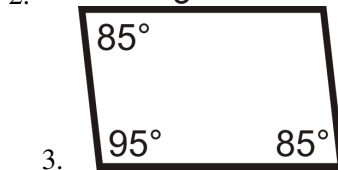
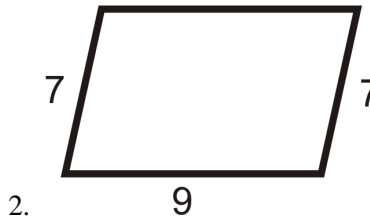
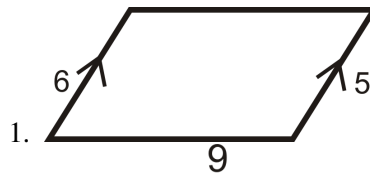

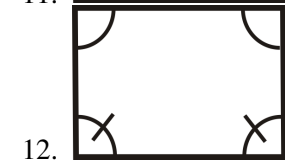
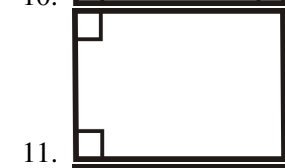
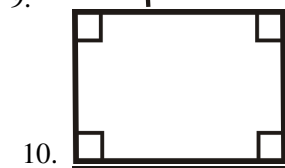
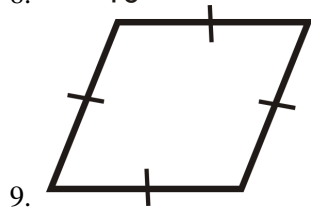
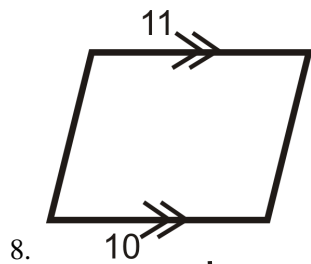

For questions 13-18, determine the value of x and y that would make the quadrilateral a parallelogram.

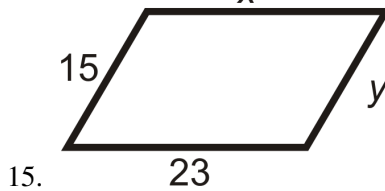
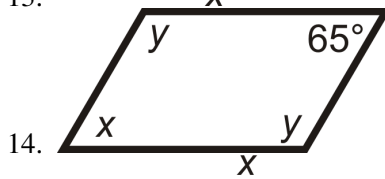
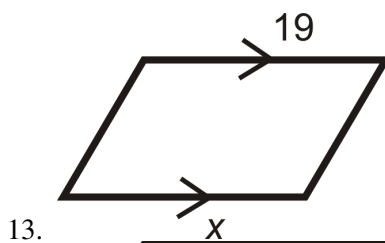

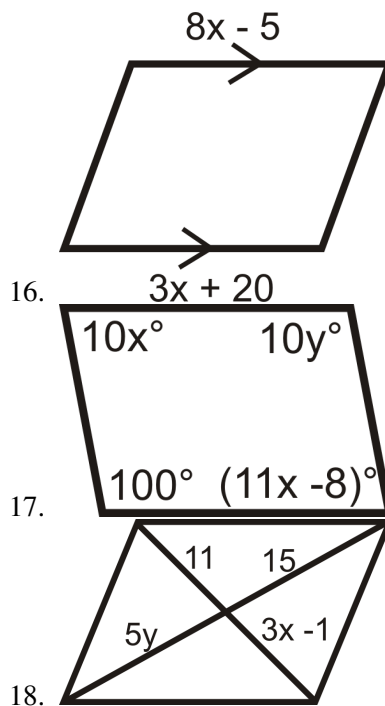

For questions 19-22, determine if $ABCD$ is a parallelogram.

19. $A(8, -1), B(6, 5), C(-7, 2), D(-5, -4)$
20. $A(-5, 8), B(-2, 9), C(3, 4), D(0, 3)$
21. $A(-2, 6), B(4, -4), C(13, -7), D(4, -10)$
22. $A(-9, -1), B(-7, 5), C(3, 8), D(1, 2)$

Fill in the blanks in the proofs below.

23. *Opposite Angles Theorem Converse*

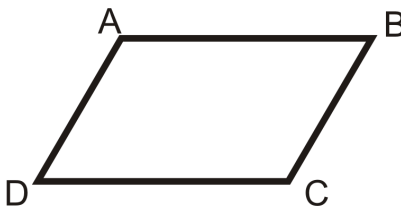

Given: $\angle A \cong \angle C, \angle D \cong \angle B$

Prove: $ABCD$ is a parallelogram

TABLE 6.7:

Statement

- 1.
2. $m\angle A = m\angle C, m\angle D = m\angle B$
- 3.
4. $m\angle A + m\angle A + m\angle B + m\angle B = 360^\circ$
- 5.
- 6.

Reason

- 1.
- 2.
3. Definition of a quadrilateral
- 4.
5. Combine Like Terms
6. Division PoE

TABLE 6.7: (continued)

<i>Statement</i>	<i>Reason</i>
7. $\angle A$ and $\angle B$ are supplementary $\angle A$ and $\angle D$ are supplementary	7.
8.	8. Consecutive Interior Angles Converse
9. $ABCD$ is a parallelogram	9.

24. *Parallelogram Diagonals Theorem Converse*

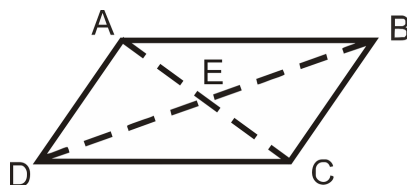

Given: $\overline{AE} \cong \overline{EC}, \overline{DE} \cong \overline{EB}$

Prove: $ABCD$ is a parallelogram

TABLE 6.8:

<i>Statement</i>	<i>Reason</i>
1.	1.
2.	2. Vertical Angles Theorem
3. $\triangle AED \cong \triangle CEB$ $\triangle AEB \cong \triangle CED$	3.
4.	4.
5. $ABCD$ is a parallelogram	5.

25. Given: $\angle ADB \cong \angle CBD, \overline{AD} \cong \overline{BC}$ Prove: $ABCD$ is a parallelogram

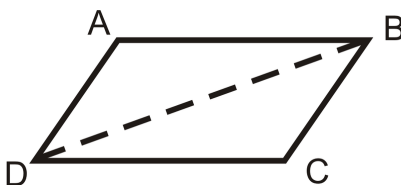

TABLE 6.9:

<i>Statement</i>	<i>Reason</i>
1.	1.
2. $\overline{AD} \parallel \overline{BC}$	2.
3. $ABCD$ is a parallelogram	3.

6.5 Parallelogram Classification

Here you'll learn what properties differentiate the three special parallelograms: rhombuses, rectangles, and squares. What if you were given a parallelogram and information about its diagonals? How could you use that information to classify the parallelogram as a rectangle, rhombus, and/or square? After completing this Concept, you'll be able to further classify a parallelogram based on its diagonals, angles, and sides.

Watch This



MEDIA

Click image to the left for more content.

CK-12 Classifying Parallelograms

Guidance

Rectangles, rhombuses (also called rhombi) and squares are all more specific versions of parallelograms, also called special parallelograms.

- A quadrilateral is a **rectangle** if and only if it has four right (congruent) angles.

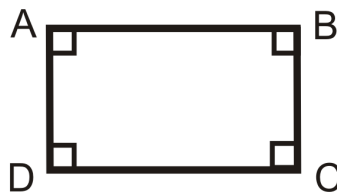

$ABCD$ is a rectangle if and only if $\angle A \cong \angle B \cong \angle C \cong \angle D$.

- A quadrilateral is a **rhombus** if and only if it has four congruent sides.

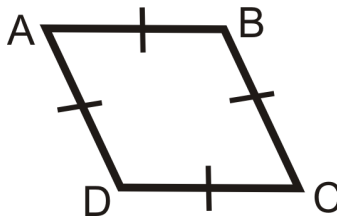

$ABCD$ is a rhombus if and only if $\overline{AB} \cong \overline{BC} \cong \overline{CD} \cong \overline{AD}$.

- A quadrilateral is a **square** if and only if it has four right angles and four congruent sides. By definition, *a square is a rectangle and a rhombus*.

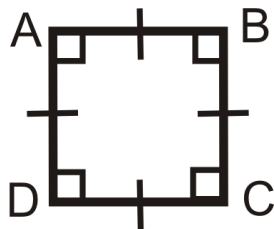

$ABCD$ is a square if and only if $\angle A \cong \angle B \cong \angle C \cong \angle D$ and $\overline{AB} \cong \overline{BC} \cong \overline{CD} \cong \overline{AD}$.

You can always show that a parallelogram is a rectangle, rhombus, or square by using the definitions of these shapes. There are some additional ways to prove parallelograms are rectangles and rhombuses, shown below:

1) A **parallelogram** is a **rectangle** if the diagonals are congruent.

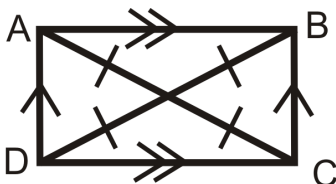

$ABCD$ is parallelogram. If $\overline{AC} \cong \overline{BD}$, then $ABCD$ is also a rectangle.

2) A **parallelogram** is a **rhombus** if the diagonals are perpendicular.

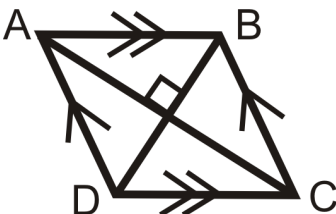

$ABCD$ is a parallelogram. If $\overline{AC} \perp \overline{BD}$, then $ABCD$ is also a rhombus.

3) A **parallelogram** is a **rhombus** if the diagonals bisect each angle.

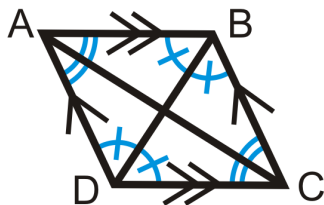

$ABCD$ is a parallelogram. If \overline{AC} bisects $\angle BAD$ and $\angle BCD$ and \overline{BD} bisects $\angle ABC$ and $\angle ADC$, then $ABCD$ is also a rhombus.

Example A

What typed of parallelogram are the figures below?

a)

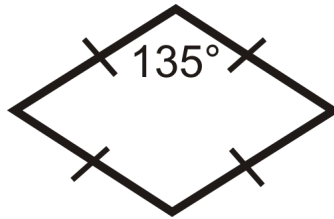

b)

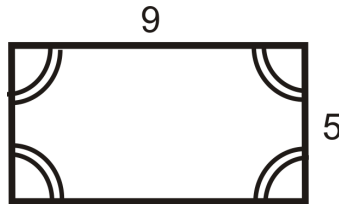
**Answer:**

a) All sides are congruent and one angle is 135° , so the angles are not congruent. This is a rhombus.

b) All four angles are congruent but the sides are not. This is a rectangle.

Example B

Is a rhombus **SOMETIMES**, **ALWAYS**, or **NEVER** a square? Explain why.

A rhombus has four congruent sides and a square has four congruent sides **and** angles. Therefore, a rhombus is a square when it has congruent angles. This means a rhombus is **SOMETIMES** a square.

Example C

List **everything** you know about the square $SQRE$.

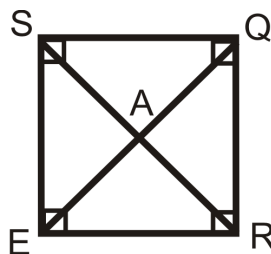

A square has all the properties of a parallelogram, rectangle and rhombus.

TABLE 6.10:**Properties of a Parallelogram**

- $\overline{SQ} \parallel \overline{ER}$

Properties of a Rhombus

- $\overline{SQ} \cong \overline{ER} \cong \overline{SE} \cong \overline{QR}$

Properties of a Rectangle

- $m\angle SER = m\angle SQR = m\angle QSE = m\angle QRE = 90^\circ$

TABLE 6.10: (continued)

Properties of a Parallelogram

- $\overline{SE} \parallel \overline{QR}$

Properties of a Rhombus

- $\overline{SR} \perp \overline{QE}$

Properties of a Rectangle

- $\angle SEQ \cong \angle QER \cong \angle SQE \cong \angle EQR$

- $\overline{SR} \cong \overline{QE}$

- $\angle QSR \cong \angle RSE \cong \angle QRS \cong \angle SRE$

- $\overline{SA} \cong \overline{AR} \cong \overline{QA} \cong \overline{AE}$

All the bisected angles are 45° .

**MEDIA**

Click image to the left for more content.

CK-12 Classifying Parallelograms

Guided Practice

1. Is a rectangle **SOMETIMES**, **ALWAYS**, or **NEVER** a parallelogram? Explain why.
2. Is a rhombus **SOMETIMES**, **ALWAYS**, or **NEVER** equiangular? Explain why.
3. Is a quadrilateral **SOMETIMES**, **ALWAYS**, or **NEVER** a pentagon? Explain why.

Answers:

1. A rectangle has two sets of parallel sides, so it is **ALWAYS** a parallelogram.
2. Any quadrilateral, including a rhombus, is only equiangular if all its angles are 90° . This means a rhombus is **SOMETIMES** equiangular, only when it is a square.
3. A quadrilateral has four sides, so it will **NEVER** be a pentagon with five sides.

Practice

1. $RACE$ is a rectangle. Find:
 - a. RG
 - b. AE
 - c. AC
 - d. EC
 - e. $m\angle RAC$

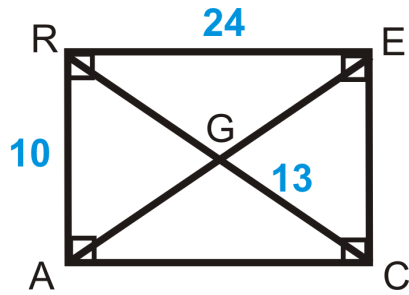

2. *DIAM* is a rhombus. Find:

- MA
- MI
- DA
- $m\angle DIA$
- $m\angle MOA$

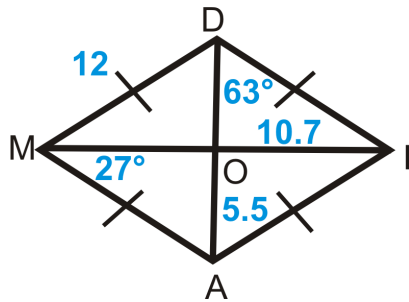



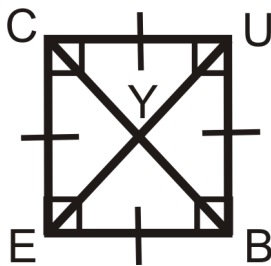

3. *CUBE* is a square. Find:

- $m\angle UCE$
- $m\angle EYB$
- $m\angle UBY$
- $m\angle UEB$

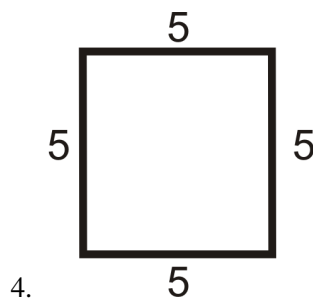

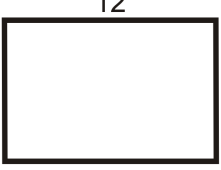
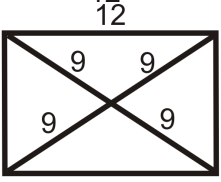
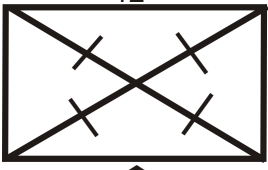
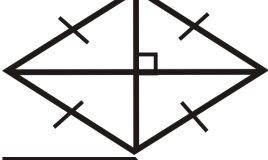
For questions 4-15, determine if the quadrilateral is a parallelogram, rectangle, rhombus, square or none.

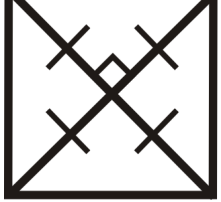

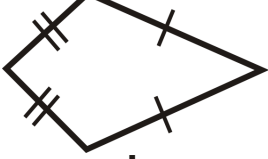
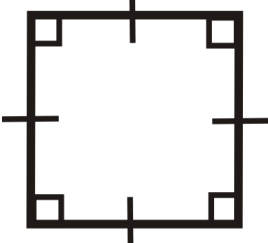
5. 
6. 
7. 
8. 
9. 
10. 
11. 
12. 
13. 
14. 

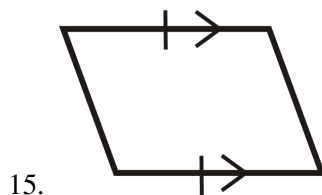

For questions 16-21 determine if the following are ALWAYS, SOMETIME, or NEVER true. Explain your reasoning.

16. A rectangle is a rhombus.
17. A square is a parallelogram.
18. A parallelogram is regular.
19. A square is a rectangle.

6.6 Trapezoids

Here you'll learn what a trapezoid is and what properties it possesses.

What if you were told that the polygon $ABCD$ is an isosceles trapezoid and that one of its base angles measures 38° ? What can you conclude about its other base angle? After completing this Concept, you'll be able to find the value of a trapezoid's unknown angles and sides.

Watch This



MEDIA

Click image to the left for more content.

CK-12 Trapezoids

Guidance

A **trapezoid** is a quadrilateral with exactly one pair of parallel sides.

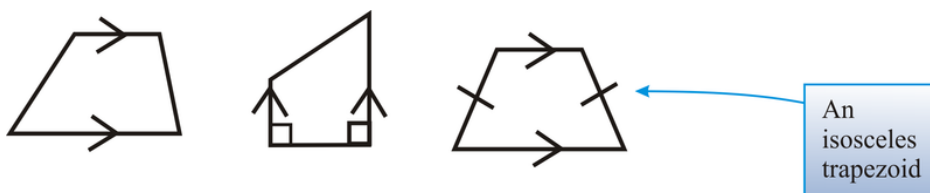

An **isosceles trapezoid** is a trapezoid where the non-parallel sides are congruent.

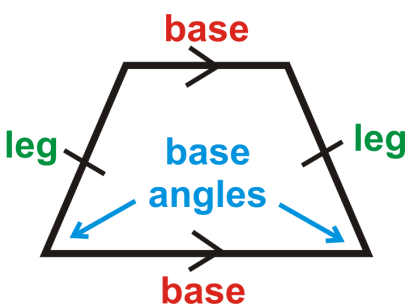

The base angles of an isosceles trapezoid are congruent. If $ABCD$ is an isosceles trapezoid, then $\angle A \cong \angle B$ and $\angle C \cong \angle D$.

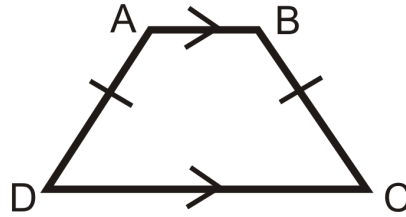

The converse is also true. If a trapezoid has congruent base angles, then it is an isosceles trapezoid. The **diagonals** of an isosceles trapezoid are also congruent. The **midsegment (of a trapezoid)** is a line segment that connects the midpoints of the non-parallel sides:

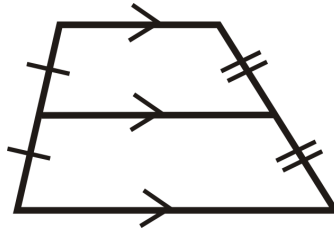

There is only one midsegment in a trapezoid. It will be parallel to the bases because it is located halfway between them.

Midsegment Theorem: The length of the midsegment of a trapezoid is the average of the lengths of the bases.

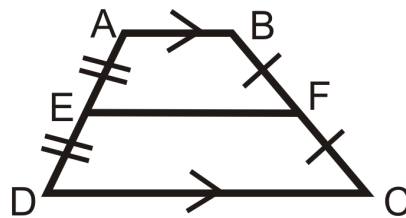

If \overline{EF} is the midsegment, then $EF = \frac{AB+CD}{2}$.

Example A

Look at trapezoid $TRAP$ below. What is $m\angle A$?

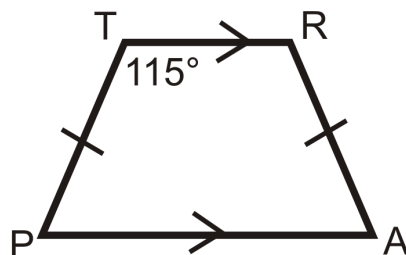

$TRAP$ is an isosceles trapezoid. $m\angle R = 115^\circ$ also.

To find $m\angle A$, set up an equation.

$$\begin{aligned}
 115^\circ + 115^\circ + m\angle A + m\angle P &= 360^\circ \\
 230^\circ + 2m\angle A &= 360^\circ & \rightarrow m\angle A = m\angle P \\
 2m\angle A &= 130^\circ \\
 m\angle A &= 65^\circ
 \end{aligned}$$

Notice that $m\angle R + m\angle A = 115^\circ + 65^\circ = 180^\circ$. These angles will always be supplementary because of the Consecutive Interior Angles Theorem.

Example B

Is $ZOID$ an isosceles trapezoid? How do you know?

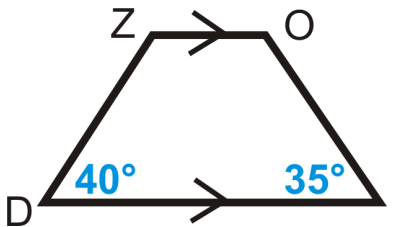

$40^\circ \neq 35^\circ$, $ZOID$ is not an isosceles trapezoid.

Example C

Find x . All figures are trapezoids with the midsegment marked as indicated.

a)

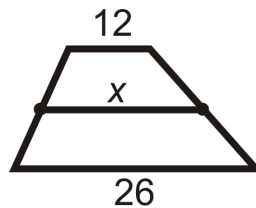

b)

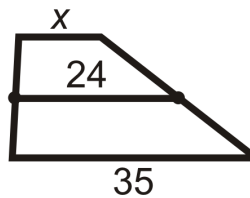

c)

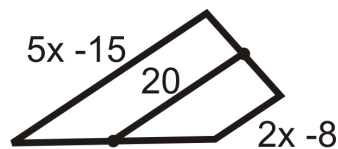

Answer:a) x is the average of 12 and 26. $\frac{12+26}{2} = \frac{38}{2} = 19$ b) 24 is the average of x and 35.

$$\frac{x+35}{2} = 24$$

$$x+35 = 48$$

$$x = 13$$

c) 20 is the average of $5x - 15$ and $2x - 8$.

$$\frac{5x-15+2x-8}{2} = 20$$

$$7x-23 = 40$$

$$7x = 63$$

$$x = 9$$



MEDIA

 Click image to the left for more content.

CK-12 Trapezoids

Guided Practice

$TRAP$ an isosceles trapezoid.

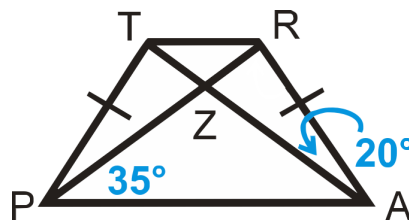

Find:

1. $m\angle TPA$
2. $m\angle PTR$
3. $m\angle PZA$
4. $m\angle ZRA$

Answers:

1. $\angle TPZ \cong \angle RAZ$ so $m\angle TPA = 20^\circ + 35^\circ = 55^\circ$.

2. $\angle TPA$ is supplementary with $\angle PTR$, so $m\angle PTR = 125^\circ$.
3. By the Triangle Sum Theorem, $35^\circ + 35^\circ + m\angle PZA = 180^\circ$, so $m\angle PZA = 110^\circ$.
4. Since $m\angle PZA = 110^\circ$, $m\angle RZA = 70^\circ$ because they form a linear pair. By the Triangle Sum Theorem, $m\angle ZRA = 90^\circ$.

Practice

1. Can the parallel sides of a trapezoid be congruent? Why or why not?
- For questions 2-7, find the length of the midsegment or missing side.

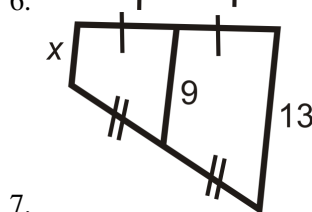
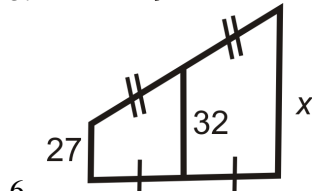
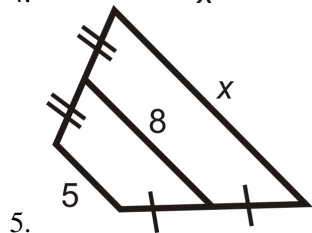
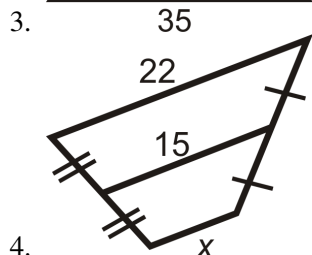
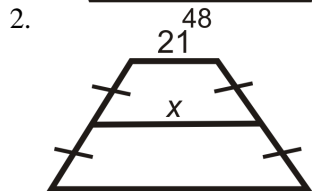
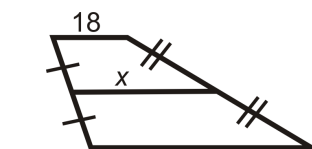

Find the value of the missing variable(s).

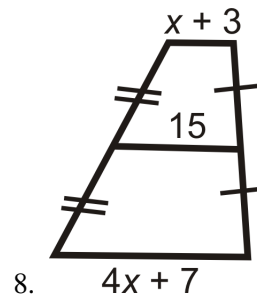

Find the lengths of the diagonals of the trapezoids below to determine if it is isosceles.

9. $A(-3, 2), B(1, 3), C(3, -1), D(-4, -2)$

10. $A(-3, 3), B(2, -2), C(-6, -6), D(-7, 1)$

6.7 Kites

Here you'll learn what a kite is and what properties it possesses.

What if you were told that *WIND* is a kite and you are given information about some of its angles or its diagonals? How would you find the measure of its other angles or its sides? After completing this Concept, you'll be able to find the value of a kite's unknown angles and sides.

Watch This



MEDIA

Click image to the left for more content.

CK-12 Kites

Guidance

A **kite** is a quadrilateral with two distinct sets of adjacent congruent sides. It looks like a kite that flies in the air.

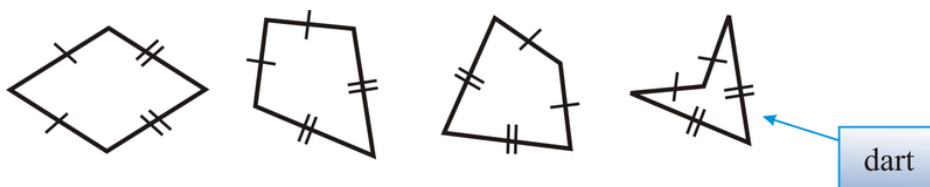

From the definition, a kite could be concave. If a kite is concave, it is called a **dart**. The word **distinct** in the definition means that the two pairs of congruent sides have to be different. This means that a square or a rhombus is not a kite.

The angles between the congruent sides are called **vertex angles**. The other angles are called **non-vertex angles**. If we draw the diagonal through the vertex angles, we would have two congruent triangles.

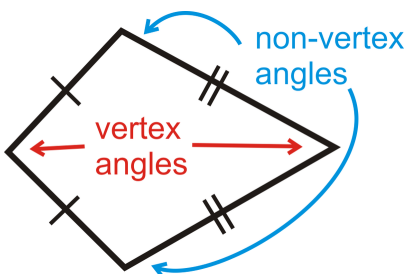

Facts about Kites

1) The non-vertex angles of a kite are congruent.

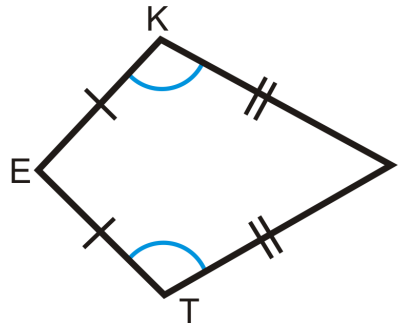

If $KITE$ is a kite, then $\angle K \cong \angle T$.

2) The diagonal through the vertex angles is the angle bisector for both angles.

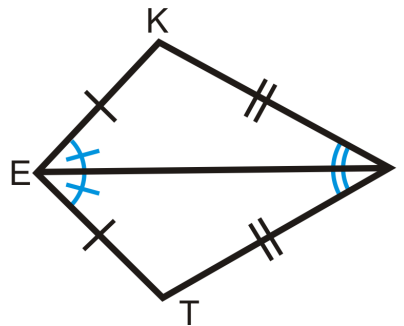

If $KITE$ is a kite, then $\angle KEI \cong \angle IET$ and $\angle KIE \cong \angle EIT$.

3) **Kite Diagonals Theorem:** The diagonals of a kite are perpendicular.

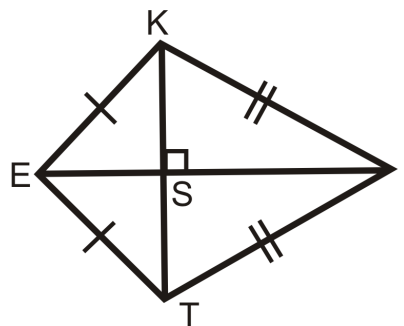

$\triangle KET$ and $\triangle KIT$ are isosceles triangles, so \overline{EI} is the perpendicular bisector of \overline{KT} (Isosceles Triangle Theorem).

Example A

Find the missing measures in the kites below.

a)

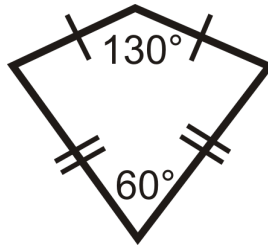

b)

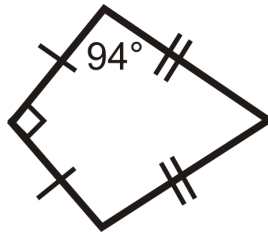
**Answer:**

a) The two angles left are the non-vertex angles, which are congruent.

$$\begin{aligned} 130^\circ + 60^\circ + x + x &= 360^\circ \\ 2x &= 170^\circ \\ x &= 85^\circ \quad \text{Both angles are } 85^\circ. \end{aligned}$$

b) The other non-vertex angle is also 94° . To find the fourth angle, subtract the other three angles from 360° .

$$\begin{aligned} 90^\circ + 94^\circ + 94^\circ + x &= 360^\circ \\ x &= 82^\circ \end{aligned}$$

Example B

Use the Pythagorean Theorem to find the lengths of the sides of the kite.

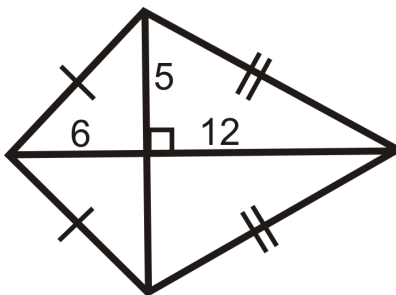

Recall that the Pythagorean Theorem says $a^2 + b^2 = c^2$, where c is the hypotenuse. In this kite, the sides are the hypotenuses.

$$6^2 + 5^2 = h^2$$

$$36 + 25 = h^2$$

$$61 = h^2$$

$$\sqrt{61} = h$$

$$12^2 + 5^2 = j^2$$

$$144 + 25 = j^2$$

$$169 = j^2$$

$$13 = j$$

Example C

Prove that the non-vertex angles of a kite are congruent.

Given: $KITE$ with $\overline{KE} \cong \overline{TE}$ and $\overline{KI} \cong \overline{TI}$

Prove: $\angle K \cong \angle T$

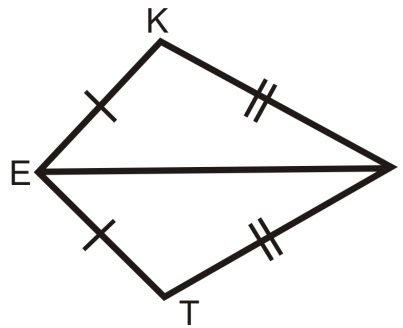

TABLE 6.11:

Statement

1. $\overline{KE} \cong \overline{TE}$ and $\overline{KI} \cong \overline{TI}$
2. $\overline{EI} \cong \overline{EI}$
3. $\triangle EKI \cong \triangle ETI$
4. $\angle K \cong \angle T$

Reason

1. Given
2. Reflexive PoC
3. SSS
4. CPCTC



MEDIA

Click image to the left for more content.

CK-12 Kites

Guided Practice

$KITE$ is a kite.

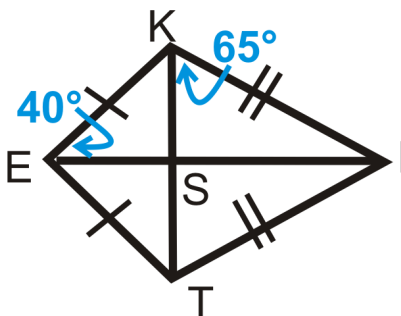

Find:

1. $m\angle KIS$
2. $m\angle IST$
3. $m\angle SIT$

Answers:

1. $m\angle KIS = 25^\circ$ by the Triangle Sum Theorem (remember that $\angle KSI$ is a right angle because the diagonals are perpendicular.)
2. $m\angle IST = 90^\circ$ because the diagonals are perpendicular.
3. $m\angle SIT = 25^\circ$ because it is congruent to $\angle KIS$.

Practice

For questions 1-6, find the value of the missing variable(s). All figures are kites.

- 1.
- 2.
- 3.
- 4.

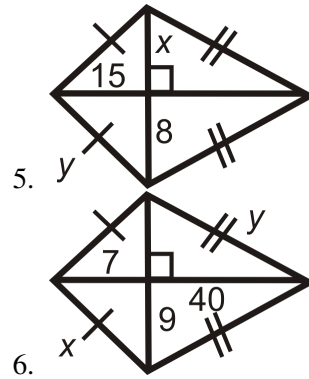

For questions 7-11, find the value of the missing variable(s).

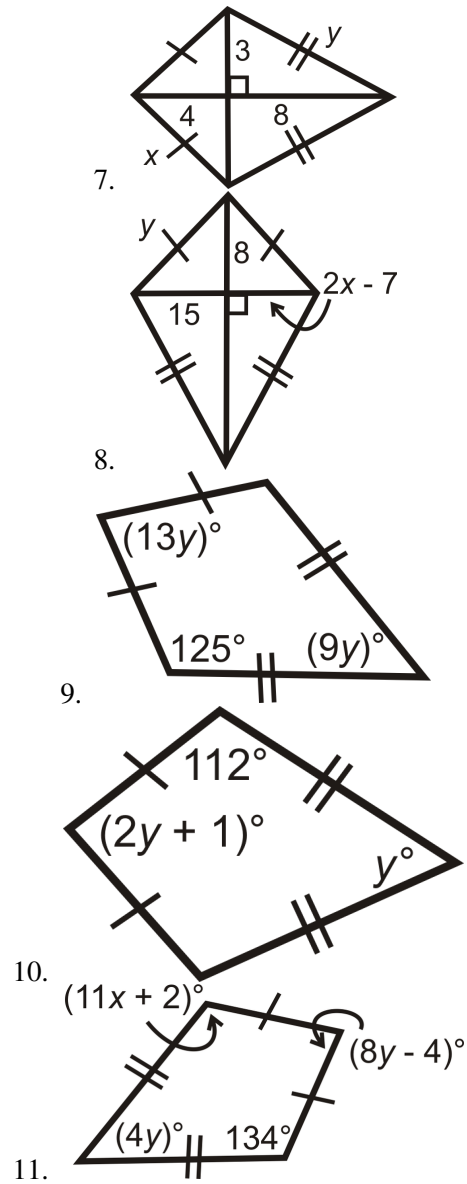

12. Fill in the blanks to the proof below.

Given: $\overline{KE} \cong \overline{TE}$ and $\overline{KI} \cong \overline{TI}$

Prove: \overline{EI} is the angle bisector of $\angle KET$ and $\angle KIT$

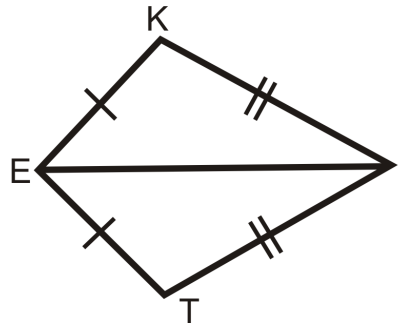

TABLE 6.12:

<i>Statement</i>	<i>Reason</i>
1. $\overline{KE} \cong \overline{TE}$ and $\overline{KI} \cong \overline{TI}$	1.
2. $\overline{EI} \cong \overline{EI}$	2.
3. $\triangle EKI \cong \triangle ETI$	3.
4.	4. CPCTC
5. \overline{EI} is the angle bisector of $\angle KET$ and $\angle KIT$	5.

13. Fill in the blanks to the proof below.

Given: $\overline{EK} \cong \overline{ET}, \overline{KI} \cong \overline{TI}$

Prove: $\overline{KT} \perp \overline{EI}$

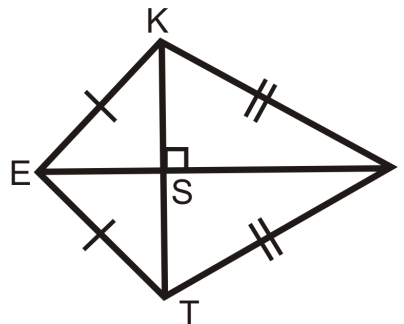

TABLE 6.13:

<i>Statement</i>	<i>Reason</i>
1. $\overline{KE} \cong \overline{TE}$ and $\overline{KI} \cong \overline{TI}$	1.
2.	2. Definition of isosceles triangles
3. \overline{EI} is the angle bisector of $\angle KET$ and $\angle KIT$	3.
4.	4. Isosceles Triangle Theorem
5. $\overline{KT} \perp \overline{EI}$	5.

6.8 Quadrilateral Classification

Here you'll learn how to differentiate among parallelograms, rectangles, rhombuses, squares, kites, trapezoids, and quadrilaterals in the coordinate plane.

What if you were given the coordinates of four points that form a quadrilateral? How could you determine if that quadrilateral qualifies as one of the special four-sided figures you learned about in the previous Concepts? After completing this Concept, you'll be able to make such a determination.

Watch This



MEDIA

Click image to the left for more content.

CK-12 Classifying Quadrilaterals in the Coordinate Plane

Guidance

In order to be successful in this concept you need to already be familiar with the definitions and properties of the following quadrilaterals: parallelograms, rhombuses, rectangles, squares, kites and trapezoids. The definitions for each are provided in the vocabulary section as a resource, and further information can be found by searching on those topic words.

When working in the coordinate plane, you will sometimes want to know what type of shape a given shape is. You should easily be able to tell that it is a quadrilateral if it has four sides. But how can you classify it beyond that?

First you should graph the shape if it has not already been graphed. Look at it and see if it looks like any special quadrilateral. Do the sides appear to be congruent? Do they meet at right angles? This will give you a place to start.

Once you have a guess for what type of quadrilateral it is, your job is to prove your guess. To prove that a quadrilateral is a parallelogram, rectangle, rhombus, square, kite or trapezoid, you must show that it meets the definition of that shape OR that it has properties that only that shape has.

If it turns out that your guess was wrong because the shape does not fulfill the necessary properties, you can guess again. If it appears to be no type of special quadrilateral then it is simply a *quadrilateral*.

The examples below will help you to see what this process might look like.

Example A

Determine what type of parallelogram $TUNE$ is: $T(0, 10)$, $U(4, 2)$, $N(-2, -1)$, and $E(-6, 7)$.

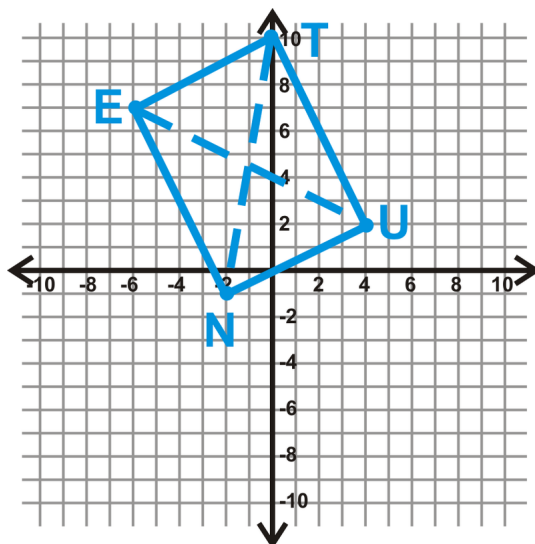

This *looks* like a rectangle. Let's see if the diagonals are equal. If they are, then $TUNE$ is a rectangle.

$$\begin{aligned} EU &= \sqrt{(-6-4)^2 + (7-2)^2} \\ &= \sqrt{(-10)^2 + 5^2} \\ &= \sqrt{100 + 25} \\ &= \sqrt{125} \end{aligned}$$

$$\begin{aligned} TN &= \sqrt{(0+2)^2 + (10+1)^2} \\ &= \sqrt{2^2 + 11^2} \\ &= \sqrt{4 + 121} \\ &= \sqrt{125} \end{aligned}$$

If the diagonals are also perpendicular, then $TUNE$ is a square.

$$\text{Slope of } EU = \frac{7-2}{-6-4} = -\frac{5}{10} = -\frac{1}{2} \quad \text{Slope of } TN = \frac{10-(-1)}{0-(-2)} = \frac{11}{2}$$

The slope of $EU \neq$ slope of TN , so $TUNE$ is a rectangle.

Example B

A quadrilateral is defined by the four lines $y = 2x + 1$, $y = -x + 5$, $y = 2x - 4$, and $y = -x - 5$. Is this quadrilateral a parallelogram?

To check if its a parallelogram we have to check that it has two pairs of parallel sides. From the equations we can see that the slopes of the lines are 2, -1 , 2 and -1 . Because two pairs of slopes match, this shape has two pairs of parallel sides and is a parallelogram.

Example C

Determine what type of quadrilateral $RSTV$ is.

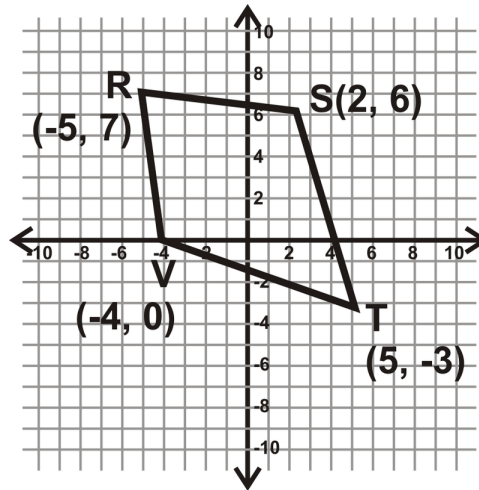

This *looks* like a kite. Find the lengths of all the sides to check if the adjacent sides are congruent.

$$\begin{aligned} RS &= \sqrt{(-5-2)^2 + (7-6)^2} \\ &= \sqrt{(-7)^2 + 1^2} \\ &= \sqrt{50} \end{aligned}$$

$$\begin{aligned} ST &= \sqrt{(2-5)^2 + (6-(-3))^2} \\ &= \sqrt{(-3)^2 + 9^2} \\ &= \sqrt{90} \end{aligned}$$

$$\begin{aligned} RV &= \sqrt{(-5-(-4))^2 + (7-0)^2} \\ &= \sqrt{(-1)^2 + 7^2} \\ &= \sqrt{50} \end{aligned}$$

$$\begin{aligned} VT &= \sqrt{(-4-5)^2 + (0-(-3))^2} \\ &= \sqrt{(-9)^2 + 3^2} \\ &= \sqrt{90} \end{aligned}$$

From this we see that the adjacent sides are congruent. Therefore, $RSTV$ is a kite.



MEDIA

Click image to the left for more content.

CK-12 Classifying Quadrilaterals in the Coordinate Plane

Guided Practice

1. A quadrilateral is defined by the four lines $y = 2x + 1$, $y = -2x + 5$, $y = 2x - 4$, and $y = -2x - 5$. Is this quadrilateral a rectangle?
2. Determine what type of quadrilateral $ABCD$ is. $A(-3, 3)$, $B(1, 5)$, $C(4, -1)$, $D(1, -5)$.
3. Determine what type of quadrilateral $EFGH$ is. $E(5, -1)$, $F(11, -3)$, $G(5, -5)$, $H(-1, -3)$

Answers:

1. To be a rectangle a shape must have four right angles. This means that the sides must be perpendicular to each other. From the given equations we see that the slopes are 2, -2 , 2 and -2 . Because the slopes are not opposite reciprocals of each other, the sides are not perpendicular, and the shape is not a rectangle.

2. First, graph $ABCD$. This will make it easier to figure out what type of quadrilateral it is. From the graph, we can tell this is not a parallelogram. Find the slopes of \overline{BC} and \overline{AD} to see if they are parallel.

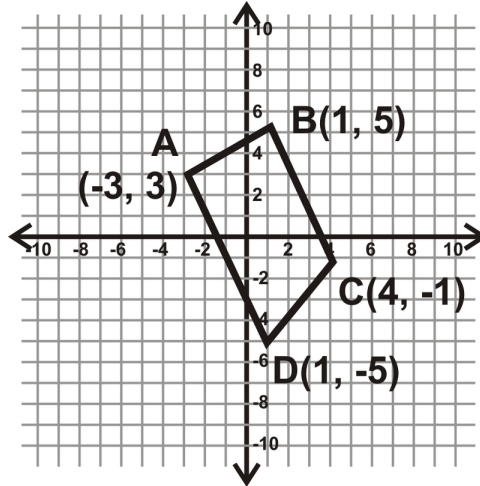

$$\text{Slope of } \overline{BC} = \frac{5 - (-1)}{1 - 4} = \frac{6}{-3} = -2$$

$$\text{Slope of } \overline{AD} = \frac{3 - (-5)}{-3 - 1} = \frac{8}{-4} = -2$$

$\overline{BC} \parallel \overline{AD}$, so $ABCD$ is a trapezoid. To determine if it is an isosceles trapezoid, find AB and CD .

$$\begin{aligned} AB &= \sqrt{(-3 - 1)^2 + (3 - 5)^2} \\ &= \sqrt{(-4)^2 + (-2)^2} \\ &= \sqrt{20} = 2\sqrt{5} \end{aligned}$$

$$\begin{aligned} ST &= \sqrt{(4 - 1)^2 + (-1 - (-5))^2} \\ &= \sqrt{3^2 + 4^2} \\ &= \sqrt{25} = 5 \end{aligned}$$

$AB \neq CD$, therefore this is not an isosceles trapezoid.

3. We will not graph this example. Let's find the length of all four sides.

$$\begin{aligned} EF &= \sqrt{(5 - 11)^2 + (-1 - (-3))^2} \\ &= \sqrt{(-6)^2 + 2^2} = \sqrt{40} \end{aligned}$$

$$\begin{aligned} \sqrt{FG} &= \sqrt{(11 - 5)^2 + (-3 - (-5))^2} \\ &= \sqrt{6^2 + 2^2} = \sqrt{40} \end{aligned}$$

$$\begin{aligned} GH &= \sqrt{(5 - (-1))^2 + (-5 - (-3))^2} \\ &= \sqrt{6^2 + (-2)^2} = \sqrt{40} \end{aligned}$$

$$\begin{aligned} HE &= \sqrt{(-1 - 5)^2 + (-3 - (-1))^2} \\ &= \sqrt{(-6)^2 + (-2)^2} = \sqrt{40} \end{aligned}$$

All four sides are equal. This quadrilateral is either a **rhombus** or a **square**. Let's find the length of the diagonals.

$$\begin{aligned} EG &= \sqrt{(5 - 5)^2 + (-1 - (-5))^2} \\ &= \sqrt{0^2 + 4^2} \\ &= \sqrt{16} = 4 \end{aligned}$$

$$\begin{aligned} FH &= \sqrt{(11 - (-1))^2 + (-3 - (-3))^2} \\ &= \sqrt{12^2 + 0^2} \\ &= \sqrt{144} = 12 \end{aligned}$$

The diagonals are not congruent, so $EFGH$ is a rhombus and not a square.

Practice

Determine what type of quadrilateral $ABCD$ is.

1. $A(-2, 4), B(-1, 2), C(-3, 1), D(-4, 3)$
2. $A(-2, 3), B(3, 4), C(2, -1), D(-3, -2)$
3. $A(1, -1), B(7, 1), C(8, -2), D(2, -4)$
4. $A(10, 4), B(8, -2), C(2, 2), D(4, 8)$
5. $A(0, 0), B(5, 0), C(0, 4), D(5, 4)$
6. $A(-1, 0), B(0, 1), C(1, 0), D(0, -1)$
7. $A(2, 0), B(3, 5), C(5, 0), D(6, 5)$

$SRUE$ is a rectangle and $PRUC$ is a square.

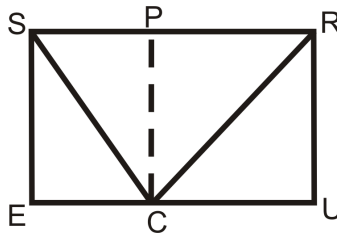

8. What type of quadrilateral is $SPCE$?
9. If $SR = 20$ and $RU = 12$, find CE .
10. Find SC and RC based on the information from part b. Round your answers to the nearest hundredth.

For questions 11-14, determine what type of quadrilateral $ABCD$ is. If it is no type of special quadrilateral, just write *quadrilateral*.

11. $A(1, -2), B(7, -5), C(4, -8), D(-2, -5)$
12. $A(6, 6), B(10, 8), C(12, 4), D(8, 2)$
13. $A(-1, 8), B(1, 4), C(-5, -4), D(-5, 6)$
14. $A(5, -1), B(9, -4), C(6, -10), D(3, -5)$

Summary

This chapter introduces the Polygon Sum Formula and the Regular Polygon Interior Angle Formula. After this detailed presentation of the interior angles of polygons, the next topic is exterior angles of polygons and the Exterior Angle Sum Theorem. Quadrilaterals, parallelograms, rectangles, squares, trapezoids, kites, and rhombuses are introduced and these various types of four-sided figures are classified and their properties are explored.

CHAPTER 7**Similarity****Chapter Outline**

- 7.1 FORMS OF RATIOS**
 - 7.2 PROPORTION PROPERTIES**
 - 7.3 SIMILAR POLYGONS AND SCALE FACTORS**
 - 7.4 AA SIMILARITY**
 - 7.5 INDIRECT MEASUREMENT**
 - 7.6 SSS SIMILARITY**
 - 7.7 SAS SIMILARITY**
 - 7.8 TRIANGLE PROPORTIONALITY**
 - 7.9 PARALLEL LINES AND TRANSVERSALS**
 - 7.10 PROPORTIONS WITH ANGLE BISECTORS**
 - 7.11 DILATION**
 - 7.12 DILATION IN THE COORDINATE PLANE**
 - 7.13 SELF-SIMILARITY**
-

Introduction

In this chapter, we will start with a review of ratios and proportions. Second, we will introduce the concept of similarity and apply it to polygons, quadrilaterals and triangles. Then, we will extend proportionality to parallel lines and dilations. Finally, we conclude with an extension about fractals.

7.1 Forms of Ratios

Here you'll learn what a ratio is and the different forms it can take. You'll also learn how to find and reduce ratios and how to convert measurements using ratios.

What if you were told that there were 15 birds on a pond and that the ratio of ducks to geese is 2:3? How could you determine how many ducks and how many geese are on the pond? After completing this Concept, you'll be able to solve problems like this one.

Watch This



MEDIA

Click image to the left for more content.

CK-12 Using Ratios

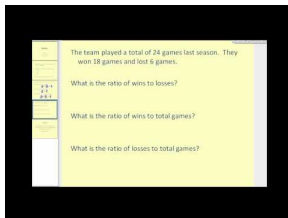

MEDIA

Click image to the left for more content.

James Sousa:Ratios

Guidance

A **ratio** is a way to compare two numbers. Ratios can be written in three ways: $\frac{a}{b}$, $a : b$, and a to b .

We always reduce ratios just like fractions. When two or more ratios reduce to the same ratio they are called **equivalent ratios**. For example, 50:250 and 2:10 are **equivalent ratios** because they both reduce to 1:5.

One common use of ratios is as a way to convert measurements.

Example A

There are 14 girls and 18 boys in your math class. What is the ratio of girls to boys?

Remember that order matters. The question asked for the ratio of *girls* to *boys*. The ratio would be 14:18. This can be simplified to 7:9.

Example B

Simplify the following ratios.

a) $\frac{7 \text{ ft}}{14 \text{ in}}$

b) 9m:900cm

c) $\frac{4 \text{ gal}}{16 \text{ gal}}$

First, change each ratio so that each part is in the same units. Remember that there are 12 inches in a foot.

a)

$$\frac{7 \cancel{\text{ft}}}{14 \cancel{\text{in}}} \cdot \frac{12 \cancel{\text{in}}}{1 \cancel{\text{ft}}} = \frac{84}{14} = \frac{6}{1}$$

The inches and feet cancel each other out. *Simplified ratios do not have units.*

b) It is easier to simplify a ratio when written as a fraction.

$$\frac{9 \cancel{\text{m}}}{900 \cancel{\text{cm}}} \cdot \frac{100 \cancel{\text{cm}}}{1 \cancel{\text{m}}} = \frac{900}{900} = \frac{1}{1}$$

c)

$$\frac{4 \cancel{\text{gal}}}{16 \cancel{\text{gal}}} = \frac{1}{4}$$

Example C

A talent show has dancers and singers. The ratio of dancers to singers is 3:2. There are 30 performers total, how many of each are there?

To solve, notice that 3:2 is a reduced ratio, so there is a number, n , that we can multiply both by to find the total number in each group. Represent dancers and singers as expressions in terms of n . Then set up and solve an equation.

$$\begin{aligned} \text{dancers} = 3n, \text{ singers} = 2n &\longrightarrow 3n + 2n = 30 \\ 5n &= 30 \\ n &= 6 \end{aligned}$$

There are $3 \cdot 6 = 18$ dancers and $2 \cdot 6 = 12$ singers.



MEDIA

Click image to the left for more content.

[CK-12 Using Ratios](#)

Guided Practice

The total bagel sales at a bagel shop for Monday is in the table below.

TABLE 7.1:

<i>Type of Bagel</i>	<i>Number Sold</i>
Plain	80
Cinnamon Raisin	30
Sesame	25
Jalapeno Cheddar	20
Everything	45
Honey Wheat	50

1. What is the ratio of cinnamon raisin bagels to plain bagels?
2. What is the ratio of honey wheat bagels to total bagels sold?
3. What is the ratio of cinnamon raisin bagels to sesame bagels to jalapeno cheddar bagels?

Answers:

1. The ratio is 30:80. Reducing the ratio by 10, we get 3:8.
2. Order matters. Honey wheat is listed first, so that number comes first in the ratio (or on the top of the fraction). Find the total number of bagels sold, $80 + 30 + 25 + 20 + 45 + 50 = 250$.

The ratio is $\frac{50}{250} = \frac{1}{5}$.

3. You can have ratios that compare more than two numbers and they work just the same way. The ratio for this problem is 30:25:20, which reduces to 6:5:4.

Practice

1. The votes for president in a club election were: Smith : 24 Munoz : 32 Park : 20 Find the following ratios and write in simplest form.
 - Votes for Munoz to Smith
 - Votes for Park to Munoz
 - Votes for Smith to total votes
 - Votes for Smith to Munoz to Park

Use the picture to write the following ratios for questions 2-6.

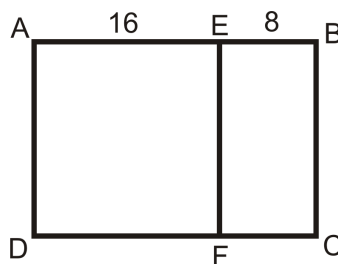

$AEFD$ is a square $ABCD$ is a rectangle

2. $AE : EF$
3. $EB : AB$
4. $DF : FC$

5. $EF : BC$
6. Perimeter $ABCD$:Perimeter $AEFD$:Perimeter $EBCF$

Simplify the following ratios. Remember that there are 12 inches in a foot, 3 feet in a yard, and 100 centimeters in a meter.

7. $\frac{25 \text{ in}}{5 \text{ ft}}$
8. $\frac{9 \text{ ft}}{3 \text{ yd}}$
9. $\frac{95 \text{ cm}}{1.5 \text{ m}}$
10. The measures of the angles of a triangle are have the ratio 3:3:4. What are the measures of the angles?
11. The length and width of a rectangle are in a 3:5 ratio. The perimeter of the rectangle is 64. What are the length and width?
12. The length and width of a rectangle are in a 4:7 ratio. The perimeter of the rectangle is 352. What are the length and width?
13. A math class has 36 students. The ratio of boys to girls is 4:5. How many girls are in the class?
14. The senior class has 450 students in it. The ratio of boys to girls is 8:7. How many boys are in the senior class?
15. The varsity football team has 50 players. The ratio of seniors to juniors is 3:2. How many seniors are on the team?

7.2 Proportion Properties

Here you'll learn what a proportion is, the properties of proportions, and how to solve proportions using cross-multiplication.

What if you were told that a scale model of a python is in the ratio of 1:24? If the model measures 0.75 feet long, how long is the real python? After completing this Concept, you'll be able to solve problems like this one by using a proportion.

Watch This



MEDIA

Click image to the left for more content.

CK-12 Proportions

First watch this video.

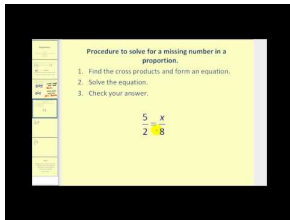

MEDIA

Click image to the left for more content.

James Sousa:Proportions

Now watch this video.

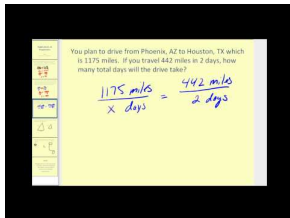

MEDIA

Click image to the left for more content.

James Sousa:Applications ofProportions

Finally, watch this video.

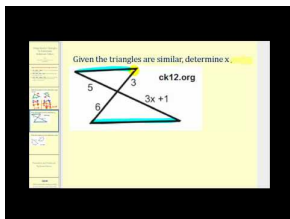

MEDIA

Click image to the left for more content.

James Sousa:Using Similar Triangles to Determine Unknown Values

Guidance

A **proportion** is two ratios that are set equal to each other. Usually the ratios in proportions are written in fraction form. An example of a proportion is $\frac{2}{x} = 510$. To solve a proportion, you need to **cross-multiply**. The **Cross-Multiplication Theorem**, which allows us to solve proportions using this method, states that if a, b, c , and d are real numbers, with $b \neq 0$ and $d \neq 0$ and if $\frac{a}{b} = \frac{c}{d}$, then $ad = bc$. Cross-multiplying allows us to get rid of the fractions in our equation. The Cross-Multiplication Theorem has several sub-theorems, called **corollaries**.

Corollary #1: If a, b, c , and d are nonzero and $\frac{a}{b} = \frac{c}{d}$, then $\frac{a}{c} = \frac{b}{d}$. **Switch band c .**

Corollary #2: If a, b, c , and d are nonzero and $\frac{a}{b} = \frac{c}{d}$, then $\frac{d}{b} = \frac{c}{a}$. **Switch a and d .**

Corollary #3: If a, b, c , and d are nonzero and $\frac{a}{b} = \frac{c}{d}$, then $\frac{b}{a} = \frac{c}{d}$. **Flip each ratio upside down.**

Corollary #4: If a, b, c , and d are nonzero and $\frac{a}{b} = \frac{c}{d}$, then $\frac{a+b}{b} = \frac{c+d}{d}$.

Corollary #5: If a, b, c , and d are nonzero and $\frac{a}{b} = \frac{c}{d}$, then $\frac{a-b}{b} = \frac{c-d}{d}$.

Example A

Solve the proportions.

a) $\frac{4}{5} = \frac{x}{30}$

b) $\frac{y+1}{8} = \frac{5}{20}$

c) $\frac{6}{5} = \frac{2x+4}{x-2}$

Remember, to solve a proportion, you need to **cross-multiply**.

a)

$$\begin{aligned} \frac{4}{5} &= \frac{x}{30} \\ 4 \cdot 30 &= 5 \cdot x \\ 120 &= 5x \\ 24 &= x \end{aligned}$$

b)

$$\begin{aligned} \frac{y+1}{8} &= \frac{5}{20} \\ (y+1) \cdot 20 &= 5 \cdot 8 \\ 20y + 20 &= 40 \\ 20y &= 20 \\ y &= 1 \end{aligned}$$

c)

$$\frac{6}{5} = \frac{2x+4}{x-2}$$

$$6 \cdot (x-2) = 5 \cdot (2x+4)$$

$$6x-12 = 10x+20$$

$$-32 = 4x$$

$$-8 = x$$

Example B

Your parents have an architect's drawing of their home. On the paper, the house's dimensions are 36 in by 30 in. If the shorter length of the house is actually 50 feet, what is the longer length?

To solve, first set up a proportion. If the shorter length is 50 feet, then it lines up with 30 in, the shorter length of the paper dimensions.

$$\frac{30}{36} = \frac{50}{x} \rightarrow 30x = 1800$$

$$x = 60 \quad \text{The longer length is 60 feet.}$$

Example C

Suppose we have the proportion $\frac{2}{5} = \frac{14}{35}$. Write three true proportions that follow.

First of all, we know this is a true proportion because you would multiply $\frac{2}{5}$ by $\frac{7}{7}$ to get $\frac{14}{35}$. Using the first three corollaries:

1. $\frac{2}{14} = \frac{5}{35}$
2. $\frac{35}{5} = \frac{14}{2}$
3. $\frac{5}{2} = \frac{35}{14}$



MEDIA

Click image to the left for more content.

CK-12 Proportions**Guided Practice**

1. In the picture, $\frac{AB}{XY} = \frac{BC}{YZ} = \frac{AC}{XZ}$.

Find the measures of AC and XY.

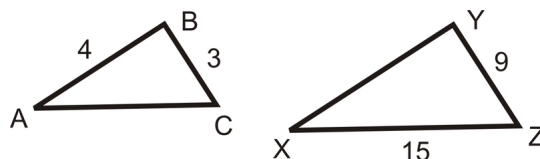

2. In the picture, $\frac{ED}{AD} = \frac{BC}{AC}$. Find y .

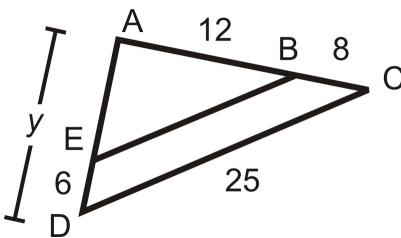

3. In the picture, $\frac{AB}{BE} = \frac{AC}{CD}$. Find BE .

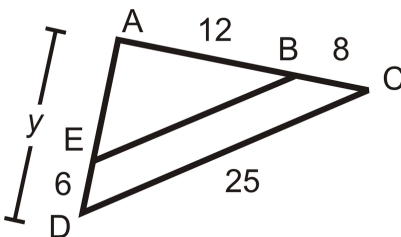

Answers:

1. Plug in the lengths of the sides we know.

$$\frac{4}{XY} = \frac{3}{9} = \frac{AC}{15}$$

$$\frac{4}{XY} = \frac{3}{9} \rightarrow 36 = 3(XY) \rightarrow XY = 12$$

$$\frac{3}{9} = \frac{AC}{15} \rightarrow 9(AC) = 45 \rightarrow AC = 5$$

2. Substitute in the lengths of the sides we know.

$$\frac{6}{y} = \frac{8}{12+8} \rightarrow 8y = 6(20) \rightarrow y = 15$$

3. Substitute in the lengths of the sides we know.

$$\frac{12}{BE} = \frac{20}{25} \rightarrow 20(BE) = 12(25) \rightarrow BE = 15$$

Practice

Solve each proportion.

1. $\frac{x}{10} = \frac{42}{35}$

2. $\frac{x}{x-2} = \frac{5}{7}$
3. $\frac{6}{9} = \frac{y}{24}$
4. $\frac{x}{9} = \frac{16}{x}$
5. $\frac{y-3}{8} = \frac{y+6}{5}$
6. $\frac{20}{z+5} = \frac{16}{7}$
7. Shawna drove 245 miles and used 8.2 gallons of gas. At the same rate, if she drove 416 miles, how many gallons of gas will she need? Round to the nearest tenth.
8. The president, vice-president, and financial officer of a company divide the profits in a 4:3:2 ratio. If the company made \$1,800,000 last year, how much did each person receive?

Given the true proportion, $\frac{10}{6} = \frac{15}{d} = \frac{x}{y}$ and $d, x,$ and y are nonzero, determine if the following proportions are also true.

9. $\frac{10}{y} = \frac{x}{6}$
10. $\frac{15}{10} = \frac{d}{6}$
11. $\frac{6+10}{10} = \frac{y+x}{x}$
12. $\frac{15}{x} = \frac{y}{d}$

For questions 13-16, $\frac{AE}{ED} = \frac{BC}{CD}$ and $\frac{ED}{AD} = \frac{CD}{DB} = \frac{EC}{AB}$.

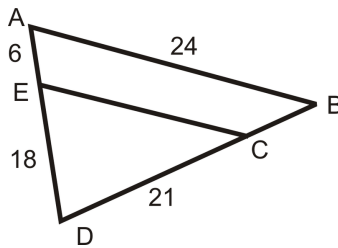

13. Find DB .
14. Find EC .
15. Find CB .
16. Find AD .

7.3 Similar Polygons and Scale Factors

Here you'll learn what properties two or more polygons must possess to be similar. You'll also learn what a scale factor is and how to solve for missing information in similar polygon problems.

What if you were told that two pentagons were similar and you were given the lengths of each pentagon's sides. How could you determine the scale factor of pentagon #1 to pentagon #2? After completing this Concept, you'll be able to answer questions like this one about similar polygons.

Watch This



MEDIA

Click image to the left for more content.

CK-12 Similar Polygons and Scale Factors

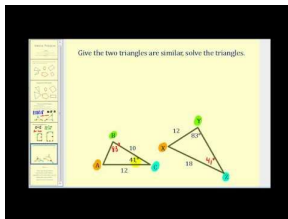

MEDIA

Click image to the left for more content.

James Sousa: Similar Polygons

Now watch this video.

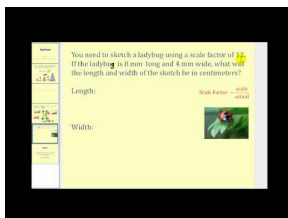

MEDIA

Click image to the left for more content.

James Sousa: Scale Factor

Guidance

Similar polygons are two polygons with the same shape, but not the same size. Similar polygons have corresponding angles that are **congruent**, and corresponding sides that are **proportional**.

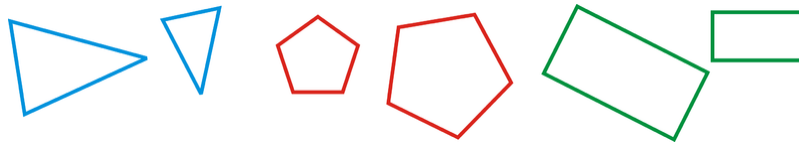

These polygons are not similar:

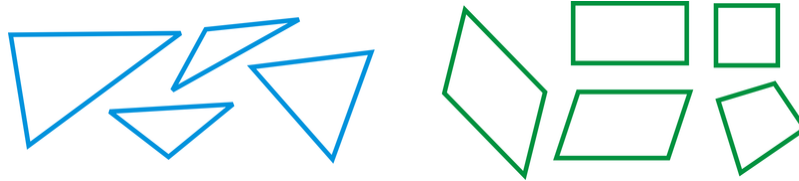

Think about similar polygons as enlarging or shrinking the same shape. The symbol \sim is used to represent similarity. Specific types of triangles, quadrilaterals, and polygons will always be similar. For example, ***all equilateral triangles are similar*** and ***all squares are similar***. If two polygons are similar, we know the lengths of corresponding sides are proportional. In similar polygons, the ratio of one side of a polygon to the corresponding side of the other is called the **scale factor**. The ratio of all parts of a polygon (including the perimeters, diagonals, medians, midsegments, altitudes) is the same as the ratio of the sides.

Example A

Suppose $\triangle ABC \sim \triangle JKL$. Based on the similarity statement, which angles are congruent and which sides are proportional?

Just like in a congruence statement, the congruent angles line up within the similarity statement. So, $\angle A \cong \angle J$, $\angle B \cong \angle K$, and $\angle C \cong \angle L$. Write the sides in a proportion: $\frac{AB}{JK} = \frac{BC}{KL} = \frac{AC}{JL}$. Note that the proportion could be written in different ways. For example, $\frac{AB}{BC} = \frac{JK}{KL}$ is also true.

Example B

$MNPQ \sim RSTU$. What are the values of x , y and z ?

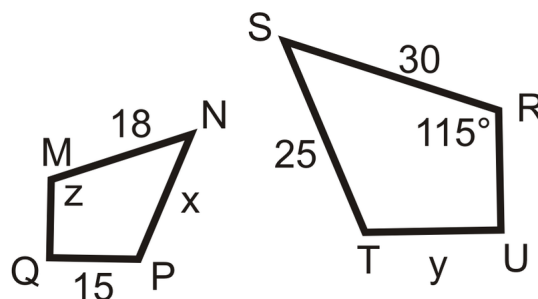

In the similarity statement, $\angle M \cong \angle R$, so $z = 115^\circ$. For x and y , set up proportions.

$$\begin{aligned}\frac{18}{30} &= \frac{x}{25} \\ 450 &= 30x \\ x &= 15\end{aligned}$$

$$\begin{aligned}\frac{18}{30} &= \frac{15}{y} \\ 18y &= 450 \\ y &= 25\end{aligned}$$

Example C

$ABCD \sim AMNP$. Find the scale factor and the length of BC .

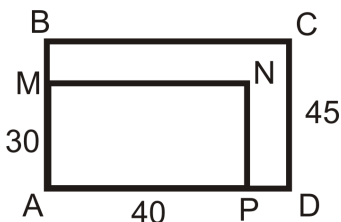

Line up the corresponding sides, AB and $AM = CD$, so the scale factor is $\frac{30}{45} = \frac{2}{3}$ or $\frac{3}{2}$. Because BC is in the bigger rectangle, we will multiply 40 by $\frac{3}{2}$ because $\frac{3}{2}$ is greater than 1. $BC = \frac{3}{2}(40) = 60$.



MEDIA
Click image to the left for more content.

CK-12 Similar Polygons and ScaleFactors

Guided Practice

1. $ABCD$ and $UVWX$ are below. Are these two rectangles similar?

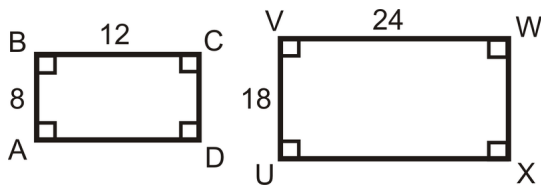

2. What is the scale factor of $\triangle ABC$ to $\triangle XYZ$? Write the similarity statement.

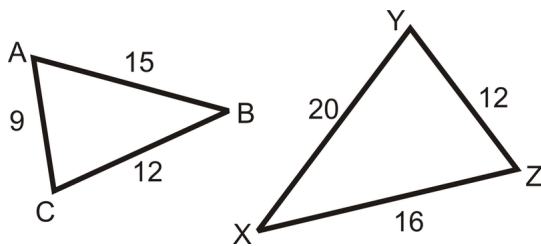

3. $\triangle ABC \sim \triangle MNP$. The perimeter of $\triangle ABC$ is 150, $AB = 32$ and $MN = 48$. Find the perimeter of $\triangle MNP$.

Answers:

1. All the corresponding angles are congruent because the shapes are rectangles.

Let's see if the sides are proportional. $\frac{8}{12} = \frac{2}{3}$ and $\frac{18}{24} = \frac{3}{4}$. $\frac{2}{3} \neq \frac{3}{4}$, so the sides are **not** in the same proportion, and the rectangles are **not** similar.

2. All the sides are in the same ratio. Pick the two largest (or smallest) sides to find the ratio.

$$\frac{15}{20} = \frac{3}{4}$$

For the similarity statement, line up the proportional sides. $AB \rightarrow XY, BC \rightarrow XZ, AC \rightarrow YZ$, so $\triangle ABC \sim \triangle YXZ$.

3. From the similarity statement, AB and MN are corresponding sides. The scale factor is $\frac{32}{48} = \frac{2}{3}$ or $\frac{3}{2}$. $\triangle ABC$ is the smaller triangle, so the perimeter of $\triangle MNP$ is $\frac{3}{2}(150) = 225$.

Practice

For questions 1-8, determine whether the following statements are true or false.

- All equilateral triangles are similar.
- All isosceles triangles are similar.
- All rectangles are similar.
- All rhombuses are similar.
- All squares are similar.
- All congruent polygons are similar.
- All similar polygons are congruent.
- All regular pentagons are similar.
- $\triangle BIG \sim \triangle HAT$. List the congruent angles and proportions for the sides.
- If $BI = 9$ and $HA = 15$, find the scale factor.
- If $BG = 21$, find HT .
- If $AT = 45$, find IG .
- Find the perimeter of $\triangle BIG$ and $\triangle HAT$. What is the ratio of the perimeters?
- An NBA basketball court is a rectangle that is 94 feet by 50 feet. A high school basketball court is a rectangle that is 84 feet by 50 feet. Are the two rectangles similar?
- HD TVs have sides in a ratio of 16:9. Non-HD TVs have sides in a ratio of 4:3. Are these two ratios equivalent?

Use the picture to the right to answer questions 16-20.

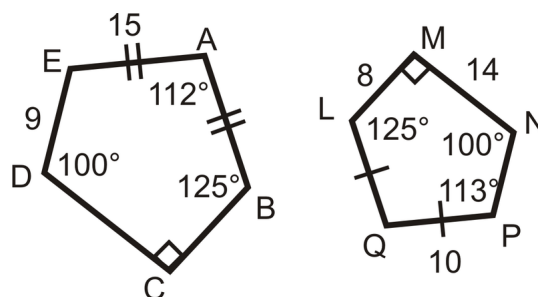

- Find $m\angle E$ and $m\angle Q$.
- $ABCDE \sim QLMNP$, find the scale factor.
- Find BC .
- Find CD .
- Find NP .

Determine if the following triangles and quadrilaterals are similar. If they are, write the similarity statement.

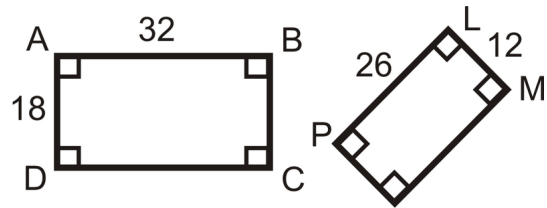

21.

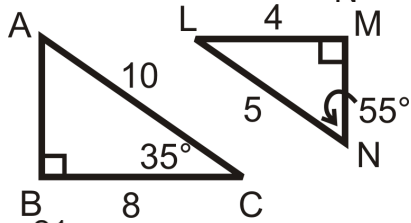

22.

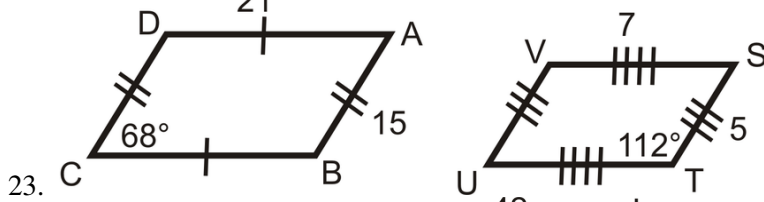

23.

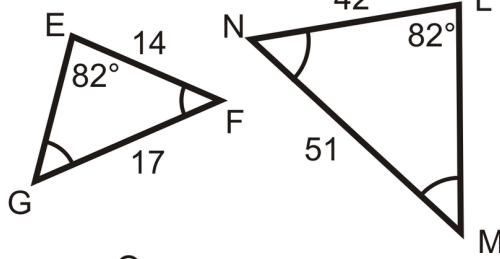

24.

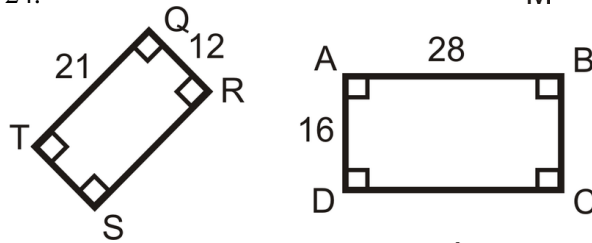

25.

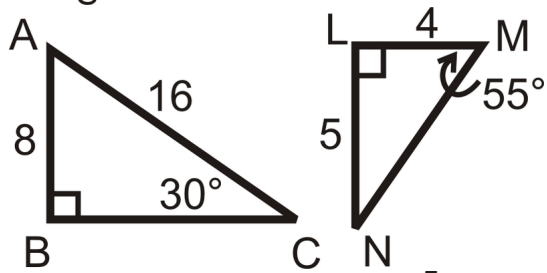

26.

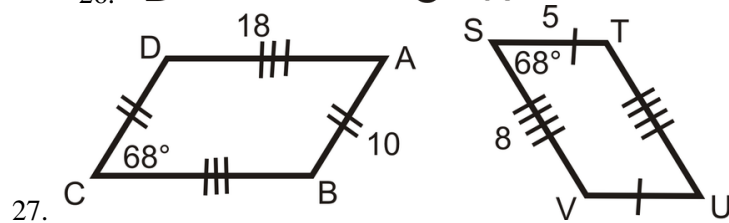

27.

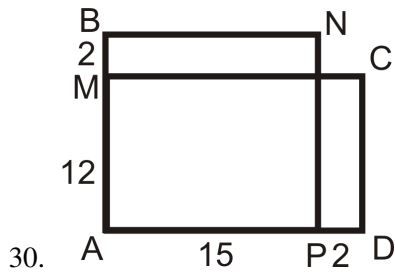
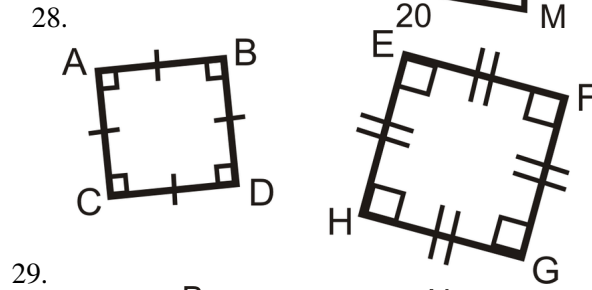
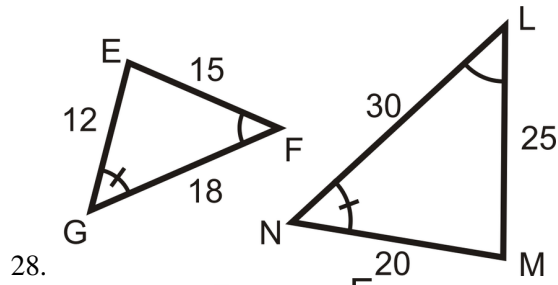

7.4 AA Similarity

Here you'll learn how to determine if triangles are similar using Angle-Angle (AA).

What if you were given a pair of triangles and the angle measures for two of their angles? How could you use this information to determine if the two triangles are similar? After completing this Concept, you'll be able to use the AA Similarity Postulate to decide if two triangles are similar.

Watch This



MEDIA

Click image to the left for more content.

CK-12 Foundation: AASimilarity

For additional help, first watch this video beginning at the 2:09 mark.

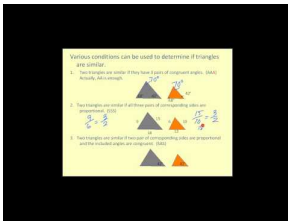

MEDIA

Click image to the left for more content.

James Sousa:SimilarTriangles

Then watch this video.

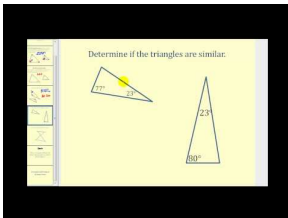

MEDIA

Click image to the left for more content.

James Sousa:SimilarTriangles by AA

Guidance

By definition, two triangles are similar if all their corresponding angles are congruent and their corresponding sides are proportional. It is not necessary to check all angles and sides in order to tell if two triangles are similar. In fact, if you only know that two pairs of corresponding angles are congruent that is enough information to know that the triangles are similar. This is called the **AA Similarity Postulate**.

AA Similarity Postulate: If two angles in one triangle are congruent to two angles in another triangle, then the two triangles are similar.

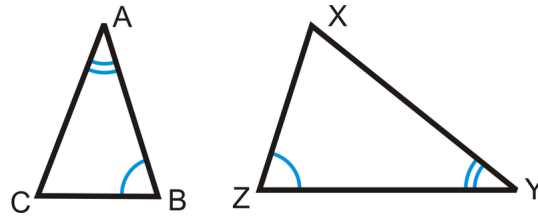

If $\angle A \cong \angle Y$ and $\angle B \cong \angle Z$, then $\triangle ABC \sim \triangle YZX$.

Example A

Determine if the following two triangles are similar. If so, write the similarity statement.

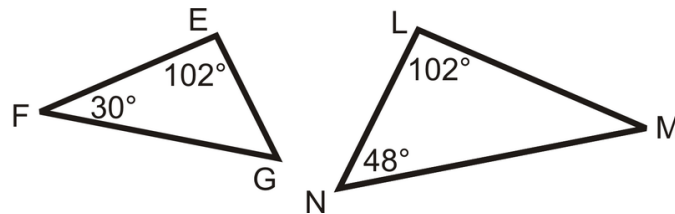

Compare the angles to see if we can use the AA Similarity Postulate. Using the Triangle Sum Theorem, $m\angle G = 48^\circ$ and $m\angle M = 30^\circ$. So, $\angle F \cong \angle M$, $\angle E \cong \angle L$ and $\angle G \cong \angle N$ and the triangles are similar. $\triangle FEG \sim \triangle MLN$.

Example B

Determine if the following two triangles are similar. If so, write the similarity statement.

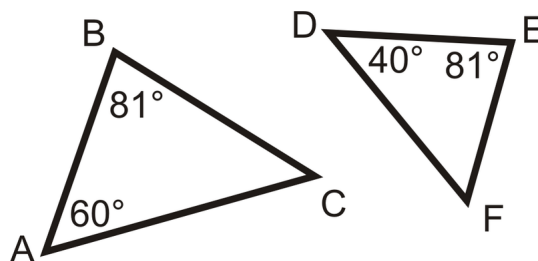

Compare the angles to see if we can use the AA Similarity Postulate. Using the Triangle Sum Theorem, $m\angle C = 39^\circ$ and $m\angle F = 59^\circ$. $m\angle C \neq m\angle F$, So $\triangle ABC$ and $\triangle DEF$ are not similar.

Example C

$\triangle LEG \sim \triangle MAR$ by AA. Find GE and MR .

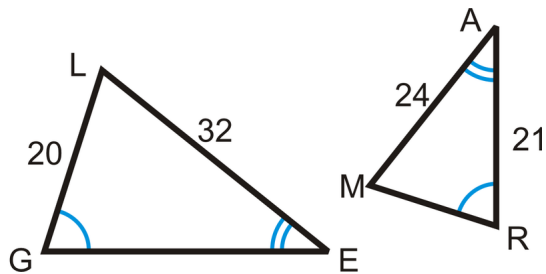

Set up a proportion to find the missing sides.

$$\frac{24}{32} = \frac{MR}{20}$$

$$480 = 32MR$$

$$15 = MR$$

$$\frac{24}{32} = \frac{21}{GE}$$

$$24GE = 672$$

$$GE = 28$$

When two triangles are similar, the corresponding sides are proportional. But, what are the corresponding sides? Using the triangles from this example, we see how the sides line up in the diagram to the right.

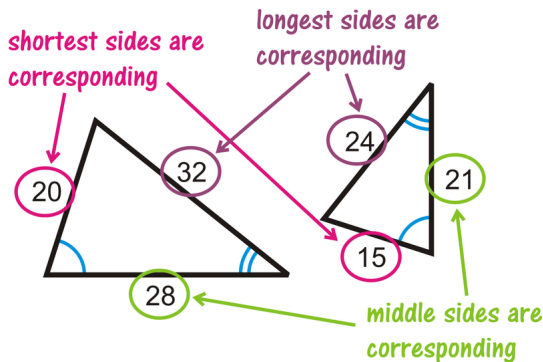

MEDIA

Click image to the left for more content.

CK-12 Foundation: AASimilarity

Guided Practice

1. Are the following triangles similar? If so, write the similarity statement.

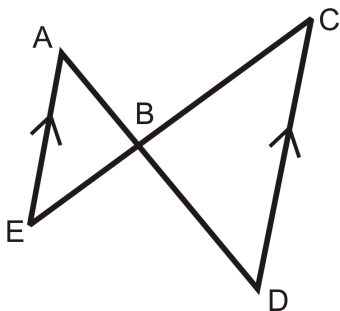

2. Are the triangles similar? If so, write a similarity statement.

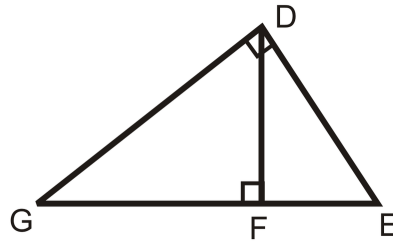

3. Are the triangles similar? If so, write a similarity statement.

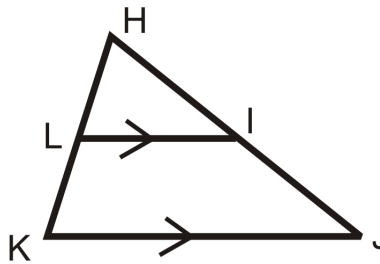

Answers:

1. Because $\overline{AE} \parallel \overline{CD}$, $\angle A \cong \angle D$ and $\angle C \cong \angle E$ by the Alternate Interior Angles Theorem. By the AA Similarity Postulate, $\triangle ABE \sim \triangle DBC$.
2. Yes, there are three similar triangles that each have a right angle. $DGE \sim FGD \sim FDE$.
3. By the reflexive property, $\angle H \cong \angle H$. Because the horizontal lines are parallel, $\angle L \cong \angle K$ (corresponding angles). So yes, there is a pair of similar triangles. $HLI \sim HKJ$.

Practice

Use the diagram to complete each statement.

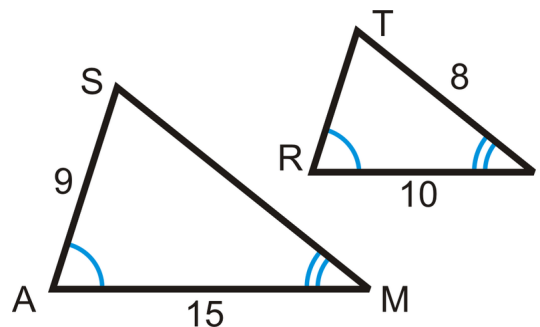

1. $\triangle SAM \sim \triangle$ _____
2. $\frac{SA}{?} = \frac{SM}{?} = \frac{?}{RI}$
3. $SM =$ _____
4. $TR =$ _____
5. $\frac{9}{?} = \frac{?}{8}$

Answer questions 6-9 about trapezoid $ABCD$.

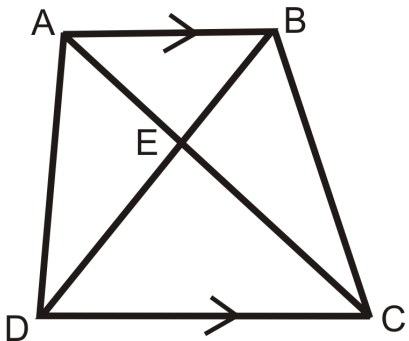

6. Name two similar triangles. How do you know they are similar?
7. Write a true proportion.
8. Name two other triangles that might *not* be similar.
9. If $AB = 10$, $AE = 7$, and $DC = 22$, find AC . Be careful!

Use the triangles to the left for questions 10-14.

$AB = 20$, $DE = 15$, and $BC = k$.

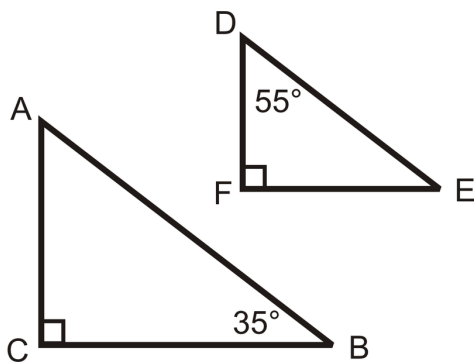

10. Are the two triangles similar? How do you know?
11. Write an expression for FE in terms of k .
12. If $FE = 12$, what is k ?
13. Fill in the blanks: If an acute angle of a _____ triangle is congruent to an acute angle in another _____ triangle, then the two triangles are _____.
14. **Writing** How do congruent triangles and similar triangles differ? How are they the same?

Are the following triangles similar? If so, write a similarity statement.

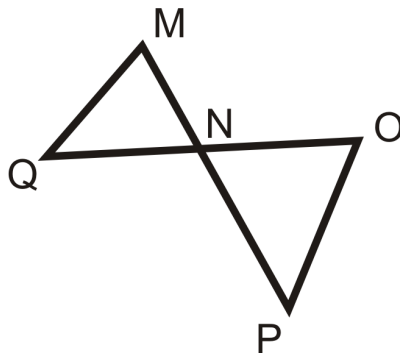

15.

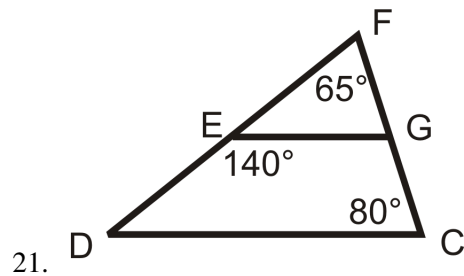
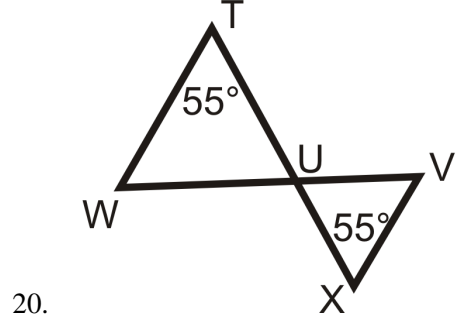
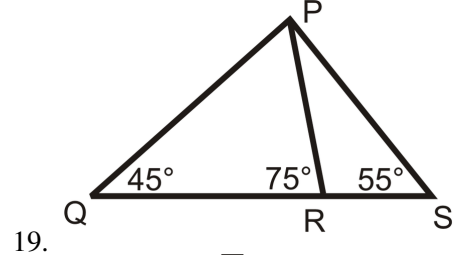
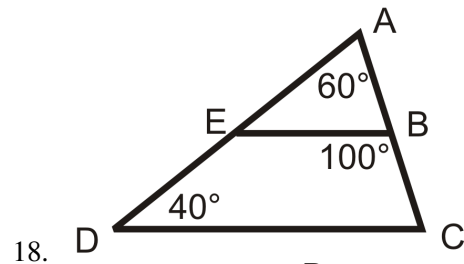
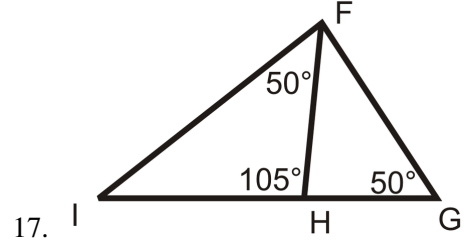
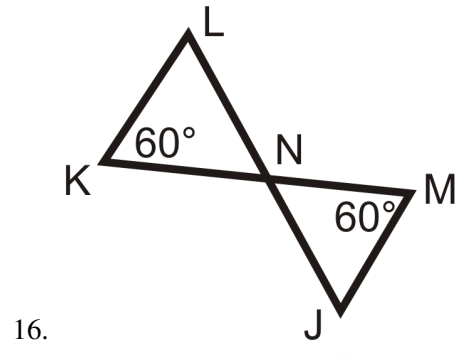

7.5 Indirect Measurement

Here you'll learn how to apply your knowledge of similar triangles and proportions to model real-life situations and to find unknown measurements indirectly.

What if you were standing next to a building and wanted to know how tall the building was? How could you use your own height and the length of the shadows cast by you and the building to determine the building's height? After completing this Concept, you'll be able to solve problems like this one.

Watch This



MEDIA

Click image to the left for more content.

CK-12 Foundation: Indirect Measurement

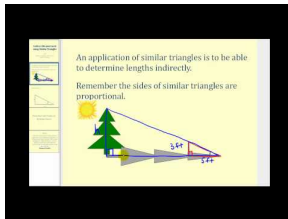

MEDIA

Click image to the left for more content.

James Sousa: Indirect Measurement Using Similar Triangles

Guidance

An application of similar triangles is to measure lengths **indirectly**. You can use this method to measure the width of a river or canyon or the height of a tall object. The idea is that you model a situation with similar triangles and then use proportions to find the missing measurement indirectly.

Example A

A tree outside Ellie's building casts a 125 foot shadow. At the same time of day, Ellie casts a 5.5 foot shadow. If Ellie is 4 feet 10 inches tall, how tall is the tree?

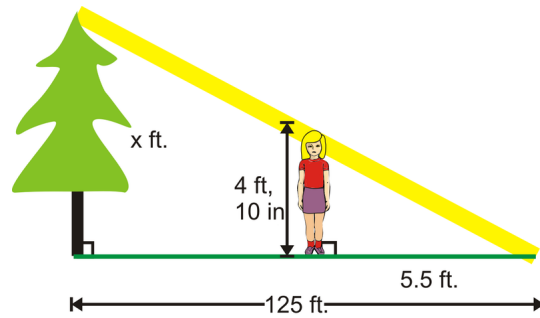

To solve, start by drawing a picture. We see that the tree and Ellie are parallel, so the two triangles are similar.

$$\frac{4 \text{ ft}, 10 \text{ in}}{x} = \frac{5.5 \text{ ft}}{125 \text{ ft}}$$

The measurements need to be in the same units. Change everything into inches and then we can cross multiply.

$$\begin{aligned} \frac{58 \text{ in}}{x} &= \frac{66 \text{ in}}{1500 \text{ in}} \\ 87000 &= 66x \\ x &\approx 1318.\overline{18} \text{ in or } 109.85 \text{ ft} \end{aligned}$$

Example B

Cameron is 5 ft tall and casts a 12 ft shadow. At the same time of day, a nearby building casts a 78 ft shadow. How tall is the building?

To solve, set up a proportion that compares height to shadow length for Cameron and the building. Then solve the equation to find the height of the building. Let x represent the height of the building.

$$\begin{aligned} \frac{5 \text{ ft}}{12 \text{ ft}} &= \frac{x}{78 \text{ ft}} \\ 12x &= 390 \\ x &= 32.5 \text{ ft} \end{aligned}$$

The building is 32.5 feet tall.

Example C

The Empire State Building is 1250 ft. tall. At 3:00, Pablo stands next to the building and has an 8 ft. shadow. If he is 6 ft tall, how long is the Empire State Building's shadow at 3:00?

Similar to Example B, solve by setting up a proportion that compares height to shadow length. Then solve the equation to find the length of the shadow. Let x represent the length of the shadow.

$$\begin{aligned} \frac{6 \text{ ft}}{8 \text{ ft}} &= \frac{1250 \text{ ft}}{x} \\ 6x &= 10000 \\ x &= 1666.67 \text{ ft} \end{aligned}$$

The shadow is approximately 1666.67 feet long.



MEDIA

Click image to the left for more content.

CK-12 Foundation: Indirect Measurement

Guided Practice

In order to estimate the width of a river, the following technique can be used. Use the diagram.

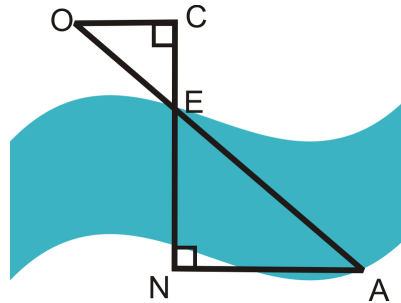

Place three markers, O , C , and E on the upper bank of the river. E is on the edge of the river and $\overline{OC} \perp \overline{CE}$. Go across the river and place a marker, N so that it is collinear with C and E . Then, walk along the lower bank of the river and place marker A , so that $\overline{CN} \perp \overline{NA}$. $OC = 50$ feet, $CE = 30$ feet, $NA = 80$ feet.

1. Is $\triangle OCE \sim \triangle ANE$? How do you know?
2. Is $\overline{OC} \parallel \overline{NA}$? How do you know?
3. What is the width of the river? Find EN .

Answers:

1. Yes. $\angle C \cong \angle N$ because they are both right angles. $\angle OEC \cong \angle AEN$ because they are vertical angles. This means $\triangle OCE \sim \triangle ANE$ by the AA Similarity Postulate.
2. Since the two triangles are similar, we must have $\angle EOC \cong \angle EAN$. These are alternate interior angles. When alternate interior angles are congruent then lines are parallel, so $\overline{OC} \parallel \overline{NA}$.
3. Set up a proportion and solve by cross-multiplying.

$$\begin{aligned} \frac{30\text{ft}}{EN} &= \frac{50\text{ft}}{80\text{ft}} \\ 50(EN) &= 2400 \\ EN &= 48 \end{aligned}$$

The river is 48 feet wide.

Practice

The technique from the guided practice section was used to measure the distance across the Grand Canyon. Use the picture below and $OC = 72$ ft, $CE = 65$ ft, and $NA = 14,400$ ft for problems 1 - 3.

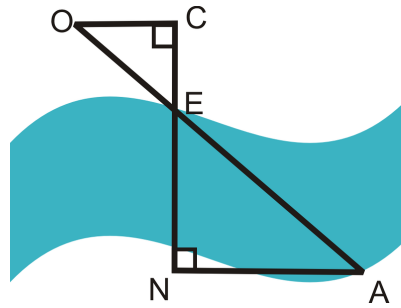

1. Find EN (the distance across the Grand Canyon).
2. Find OE .
3. Find EA .
4. Mark is 6 ft tall and casts a 15 ft shadow. At the same time of day, a nearby building casts a 30 ft shadow. How tall is the building?
5. Karen and Jeff are standing next to each other. Karen casts a 10 ft shadow and Jeff casts an 8 ft shadow. Who is taller? How do you know?
6. Billy is 5 ft 9 inches tall and Bobby is 6 ft tall. Bobby's shadow is 13 feet long. How long is Billy's shadow?
7. Sally and her little brother are walking to school. Sally is 4 ft tall and has a shadow that is 3 ft long. Her little brother's shadow is 2 ft long. How tall is her little brother?
8. Ryan is outside playing basketball. He is 5 ft tall and at this time of day is casting a 12 ft shadow. The basketball hoop is 10 ft tall. How long is the basketball hoop's shadow?
9. Jack is standing next to a very tall tree and wonders just how tall it is. He knows that he is 6 ft tall and at this moment his shadow is 8 ft long. He measures the shadow of the tree and finds it is 90 ft. How tall is the tree?
10. Thomas, who is 4 ft 9 inches tall is casting a 6 ft shadow. A nearby building is casting a 42 ft shadow. How tall is the building?

7.6 SSS Similarity

Here you'll learn how to determine if triangles are similar using Side-Side-Side (SSS).

What if you were given a pair of triangles and the side lengths for all three of their sides? How could you use this information to determine if the two triangles are similar? After completing this Concept, you'll be able to use the SSS Similarity Theorem to decide if two triangles are congruent.

Watch This



MEDIA

Click image to the left for more content.

CK-12 Foundation: SSS Similarity

Watch this video beginning at the 2:09 mark.

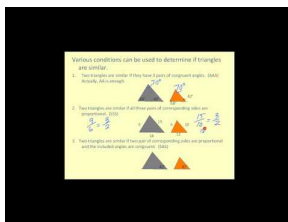

MEDIA

Click image to the left for more content.

James Sousa: Similar Triangles

Now watch the first part of this video.

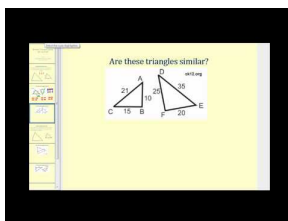

MEDIA

Click image to the left for more content.

James Sousa: Similar Triangles Using SSS and SAS

Guidance

By definition, two triangles are similar if all their corresponding angles are congruent and their corresponding sides are proportional. It is not necessary to check all angles and sides in order to tell if two triangles are similar. In fact, if

you know only that all sides are proportional, that is enough information to know that the triangles are similar. This is called the **SSS Similarity Theorem**.

SSS Similarity Theorem: If all three pairs of corresponding sides of two triangles are proportional, then the two triangles are similar.

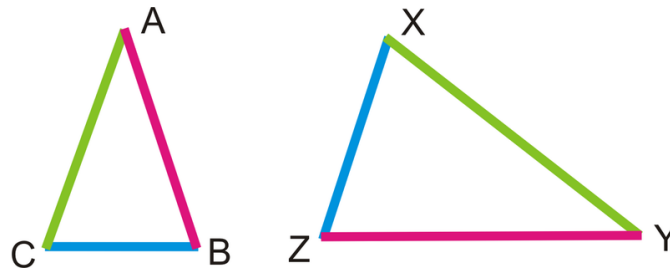

If $\frac{AB}{YZ} = \frac{BC}{ZX} = \frac{AC}{XY}$, then $\triangle ABC \sim \triangle YZX$.

Example A

Determine if the following triangles are similar. If so, explain why and write the similarity statement.

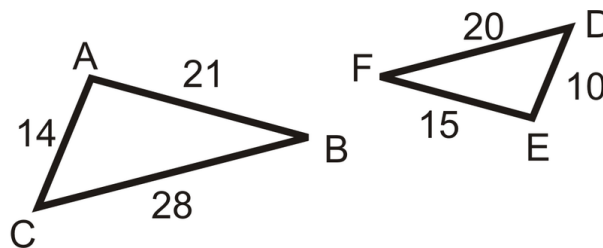

We will need to find the ratios for the corresponding sides of the triangles and see if they are all the same. Start with the longest sides and work down to the shortest sides.

$$\frac{BC}{FD} = \frac{28}{20} = \frac{7}{5}$$

$$\frac{BA}{FE} = \frac{21}{15} = \frac{7}{5}$$

$$\frac{AC}{ED} = \frac{14}{10} = \frac{7}{5}$$

Since all the ratios are the same, $\triangle ABC \sim \triangle FED$ by the SSS Similarity Theorem.

Example B

Find x and y , such that $\triangle ABC \sim \triangle DEF$.

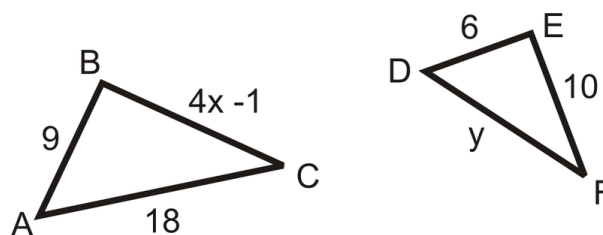

According to the similarity statement, the corresponding sides are: $\frac{AB}{DE} = \frac{BC}{EF} = \frac{AC}{DF}$. Substituting in what we know, we have $\frac{9}{6} = \frac{4x-1}{10} = \frac{18}{y}$.

$$\begin{aligned} \frac{9}{6} &= \frac{4x-1}{10} & \frac{9}{6} &= \frac{18}{y} \\ 9(10) &= 6(4x-1) & 9y &= 18(6) \\ 90 &= 24x-6 & 9y &= 108 \\ 96 &= 24x & y &= 12 \\ x &= 4 \end{aligned}$$

Example C

Determine if the following triangles are similar. If so, explain why and write the similarity statement.

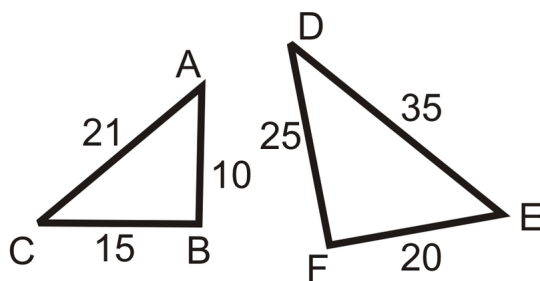

We will need to find the ratios for the corresponding sides of the triangles and see if they are all the same. Start with the longest sides and work down to the shortest sides.

$$\begin{aligned} \frac{AC}{DE} &= \frac{21}{35} = \frac{3}{5} \\ \frac{BC}{FE} &= \frac{15}{25} = \frac{3}{5} \\ \frac{AB}{DF} &= \frac{10}{25} = \frac{2}{5} \end{aligned}$$

Since the ratios are not all the same, the triangles are not similar.

**MEDIA**

Click image to the left for more content.

CK-12 Foundation: SSS Similarity

Guided Practice

Determine if any of the triangles below are similar. Compare two triangles at a time.

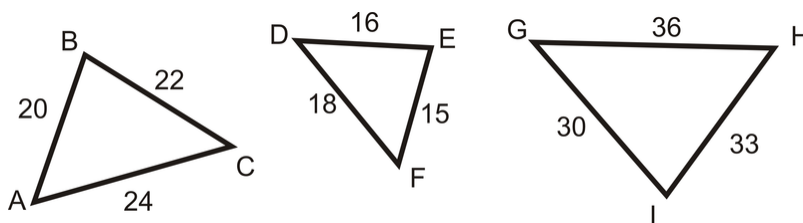

1. Is $\triangle ABC \sim \triangle DEF$?
2. Is $\triangle DEF \sim \triangle GHI$?
3. Is $\triangle ABC \sim \triangle GHI$?

Answers:

1. $\triangle ABC$ and $\triangle DEF$: Is $\frac{20}{15} = \frac{22}{16} = \frac{24}{18}$?

Reduce each fraction to see if they are equal. $\frac{20}{15} = \frac{4}{3}$, $\frac{22}{16} = \frac{11}{8}$, and $\frac{24}{18} = \frac{4}{3}$.

$\frac{4}{3} \neq \frac{11}{8}$, $\triangle ABC$ and $\triangle DEF$ are **not** similar.

2. $\triangle DEF$ and $\triangle GHI$: Is $\frac{15}{30} = \frac{16}{33} = \frac{18}{36}$?

$\frac{15}{30} = \frac{1}{2}$, $\frac{16}{33} = \frac{16}{33}$, and $\frac{18}{36} = \frac{1}{2}$. $\frac{1}{2} \neq \frac{16}{33}$, $\triangle DEF$ is **not** similar to $\triangle GHI$.

3. $\triangle ABC$ and $\triangle GHI$: Is $\frac{20}{30} = \frac{22}{33} = \frac{24}{36}$?

$\frac{20}{30} = \frac{2}{3}$, $\frac{22}{33} = \frac{2}{3}$, and $\frac{24}{36} = \frac{2}{3}$. All three ratios reduce to $\frac{2}{3}$, $\triangle ABC \sim \triangle GHI$.

Practice

Fill in the blanks.

1. If all three sides in one triangle are _____ to the three sides in another, then the two triangles are similar.
2. Two triangles are similar if the corresponding sides are _____.

Use the following diagram for questions 3-5. *The diagram is to scale.*

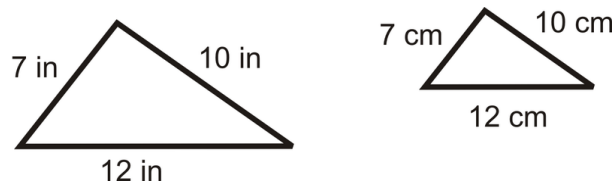

3. Are the two triangles similar? Explain your answer.
4. Are the two triangles congruent? Explain your answer.
5. What is the scale factor for the two triangles?

Fill in the blanks in the statements below. Use the diagram to the left.

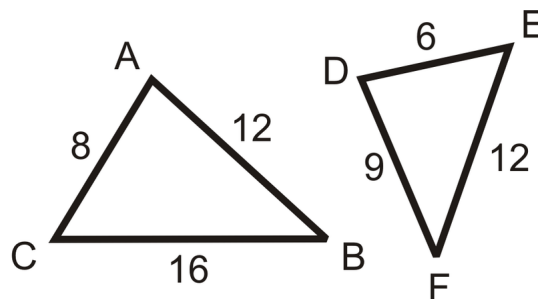

6. $\triangle ABC \sim \triangle$ _____
7. $\frac{AB}{?} = \frac{BC}{?} = \frac{AC}{?}$

8. If $\triangle ABC$ had an altitude, $AG = 10$, what would be the length of altitude \overline{DH} ?
 9. Find the perimeter of $\triangle ABC$ and $\triangle DEF$. Find the ratio of the perimeters.

Use the diagram to the right for questions 10-15.

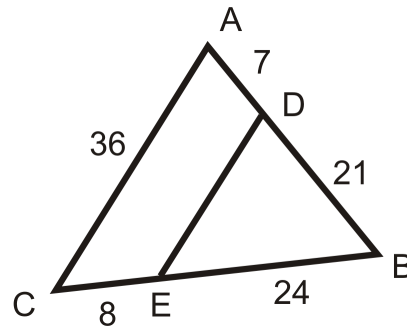

10. $\triangle ABC \sim \triangle$ _____

11. Why are the two triangles similar?

12. Find ED .

13. $\frac{BD}{?} = \frac{?}{BC} = \frac{DE}{?}$

14. Is $\frac{AD}{DB} = \frac{CE}{EB}$ true?

15. Is $\frac{AD}{DB} = \frac{AC}{DE}$ true?

Find the value of the missing variable(s) that makes the two triangles similar.

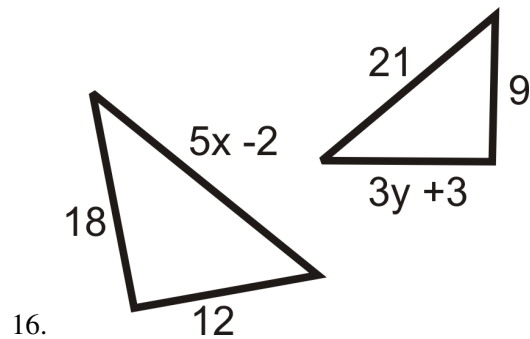

7.7 SAS Similarity

Here you'll learn how to determine if triangles are similar using Side-Angle-Side (SAS).

What if you were given a pair of triangles, the lengths of two of their sides, and the measure of the angle between those two sides? How could you use this information to determine if the two triangles are similar? After completing this Concept, you'll be able to use the SAS Similarity Theorem to decide if two triangles are congruent.

Watch This



MEDIA

Click image to the left for more content.

CK-12 Foundation: SAS Similarity

Watch this video beginning at the 2:09 mark.

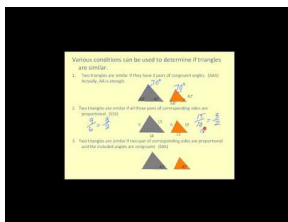

MEDIA

Click image to the left for more content.

James Sousa: Similar Triangles

Now watch the second part of this video.

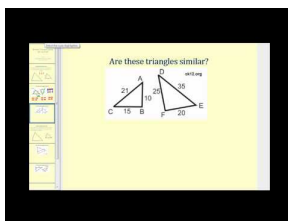

MEDIA

Click image to the left for more content.

James Sousa: Similar Triangles Using SSS and SAS

Guidance

By definition, two triangles are similar if all their corresponding angles are congruent and their corresponding sides are proportional. It is not necessary to check all angles and sides in order to tell if two triangles are similar. In fact,

if you know only that two pairs of sides are proportional and their included angles are congruent, that is enough information to know that the triangles are similar. This is called the **SAS Similarity Theorem**.

SAS Similarity Theorem: If two sides in one triangle are proportional to two sides in another triangle and the included angle in both are congruent, then the two triangles are similar.

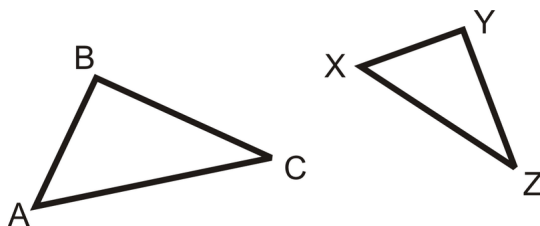

If $\frac{AB}{XY} = \frac{AC}{XZ}$ and $\angle A \cong \angle X$, then $\triangle ABC \sim \triangle XYZ$.

Example A

Are the two triangles similar? How do you know?

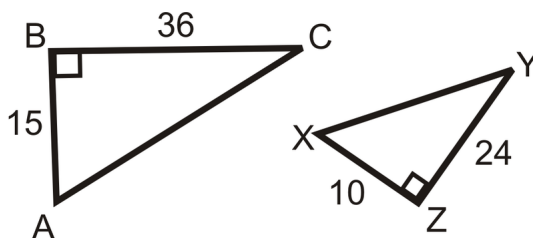

We know that $\angle B \cong \angle Z$ because they are both right angles and $\frac{10}{15} = \frac{24}{36}$. So, $\frac{AB}{XZ} = \frac{BC}{ZY}$ and $\triangle ABC \sim \triangle XZY$ by SAS.

Example B

Are there any similar triangles in the figure? How do you know?

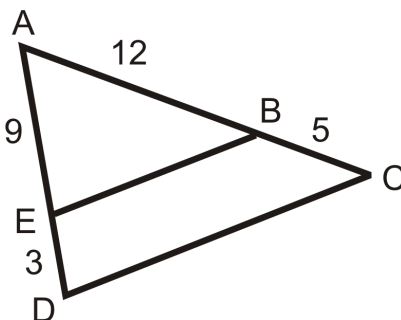

$\angle A$ is shared by $\triangle EAB$ and $\triangle DAC$, so it is congruent to itself. Let's see if $\frac{AE}{AD} = \frac{AB}{AC}$.

$$\frac{9}{9+3} = \frac{12}{12+5}$$

$$\frac{9}{12} = \frac{3}{4} \neq \frac{12}{17}$$

The two triangles are *not* similar.

Example C

From Example B, what should BC equal for $\triangle EAB \sim \triangle DAC$?

The proportion we ended up with was $\frac{9}{12} = \frac{3}{4} \neq \frac{12}{17}$. AC needs to equal 16, so that $\frac{12}{16} = \frac{3}{4}$. $AC = AB + BC$ and $16 = 12 + BC$. BC should equal 4.

**MEDIA**

Click image to the left for more content.

CK-12 Foundation: SAS Similarity

Guided Practice

Determine if the following triangles are similar. If so, write the similarity theorem and statement.

1.

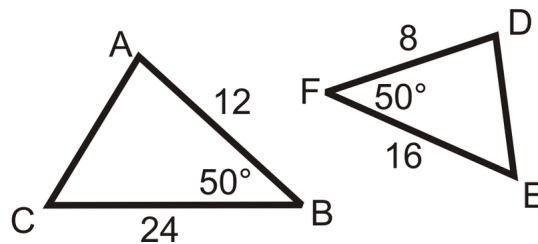

2.

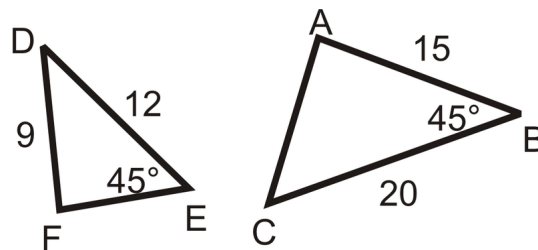

3.

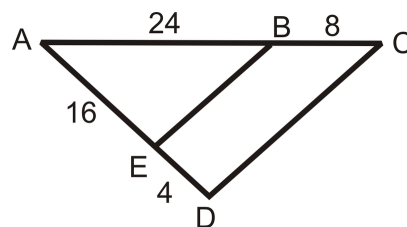
**Answers:**

1. We can see that $\angle B \cong \angle F$ and these are both included angles. We just have to check that the sides around the angles are proportional.

$$\frac{AB}{DF} = \frac{12}{8} = \frac{3}{2}$$

$$\frac{BC}{FE} = \frac{24}{16} = \frac{3}{2}$$

Since the ratios are the same $\triangle ABC \sim \triangle DFE$ by the SAS Similarity Theorem.

2. The triangles are not similar because the angle is not the included angle for both triangles.

3. $\angle A$ is the included angle for both triangles, so we have a pair of congruent angles. Now we have to check that the sides around the angles are proportional.

$$\frac{AE}{AD} = \frac{16}{16+4} = \frac{16}{20} = \frac{4}{5}$$

$$\frac{AB}{AC} = \frac{24}{24+8} = \frac{24}{32} = \frac{3}{4}$$

The ratios are not the same so the triangles are not similar.

Practice

Fill in the blanks.

- If two sides in one triangle are _____ to two sides in another and the _____ angles are _____, then the triangles are _____.

Determine if the following triangles are similar. If so, write the similarity theorem and statement.

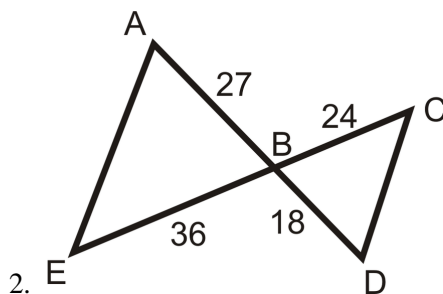

Find the value of the missing variable(s) that makes the two triangles similar.

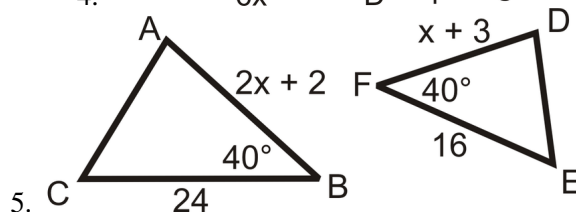
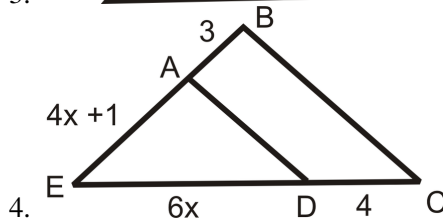
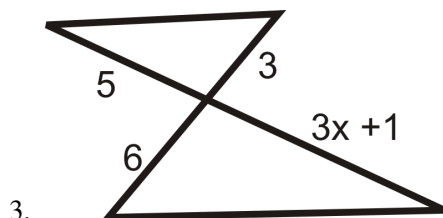

Determine if the triangles are similar. If so, write the similarity theorem and statement.

6. $\triangle ABC$ is a right triangle with legs that measure 3 and 4. $\triangle DEF$ is a right triangle with legs that measure 6 and 8.
7. $\triangle GHI$ is a right triangle with a leg that measures 12 and a hypotenuse that measures 13. $\triangle JKL$ is a right triangle with legs that measure 1 and 2.

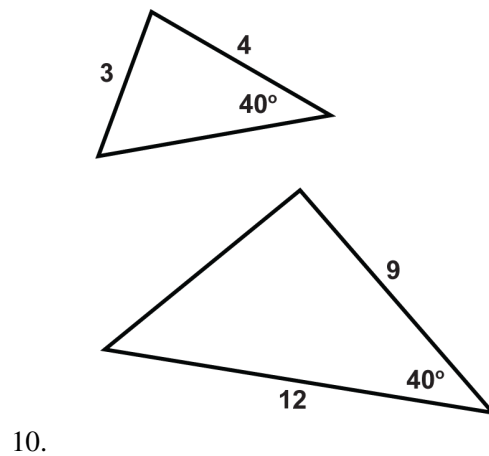
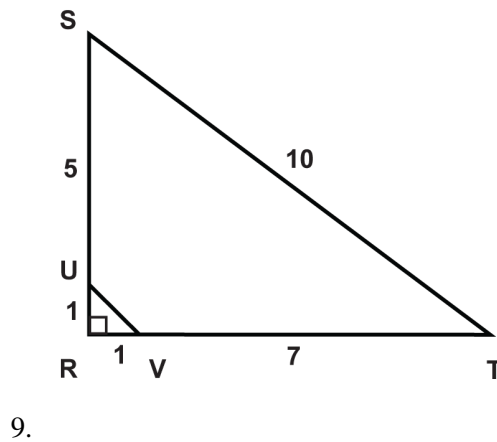
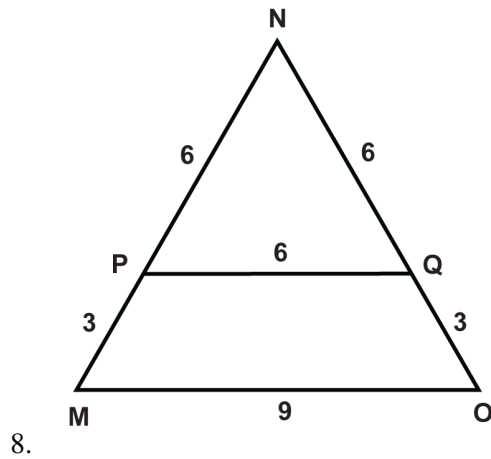

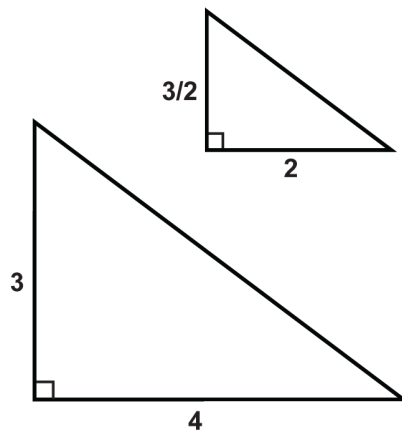

11.

12. $\overline{AC} = 3$

$\overline{DF} = 6$

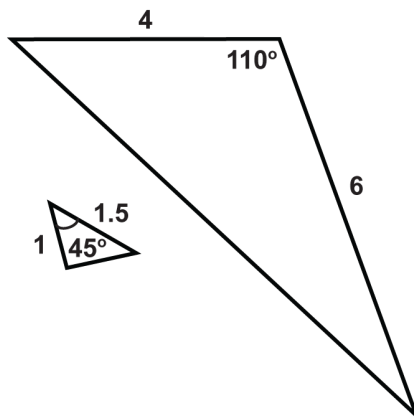
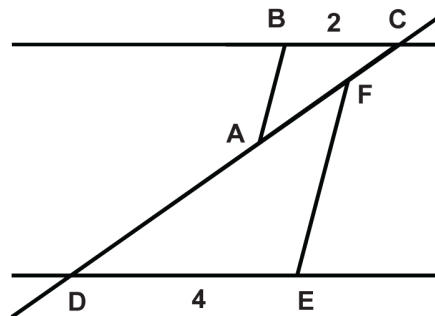

13.

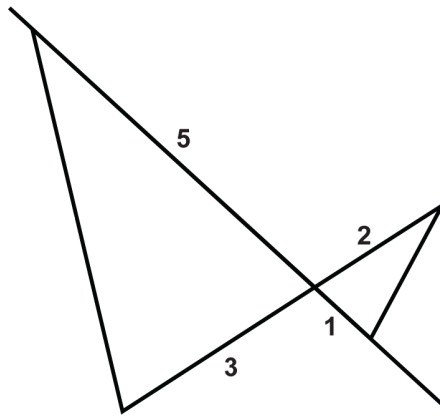

14.

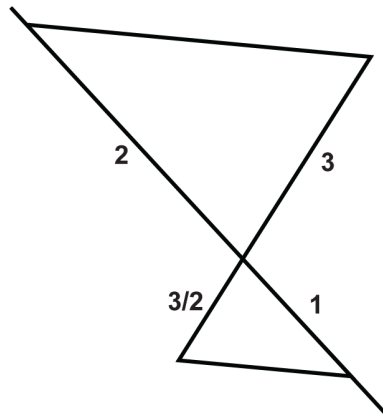

15.

7.8 Triangle Proportionality

Here you'll learn how to apply both the Triangle Proportionality Theorem, which states that if a line that is parallel to one side of a triangle intersects the other two sides, then it divides those sides proportionally, and its converse.

What if you were given a triangle with a line segment drawn through it from one side to the other? How could you use information about the triangle's side lengths to determine if that line segment is parallel to the third side? After completing this Concept, you'll be able to answer questions like this one.

Watch This



MEDIA

Click image to the left for more content.

CK-12 Foundation: Triangle Proportionality

First watch this video.

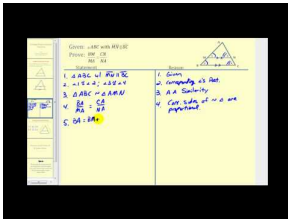

MEDIA

Click image to the left for more content.

James Sousa: Triangle Proportionality Theorem

Now watch this video.

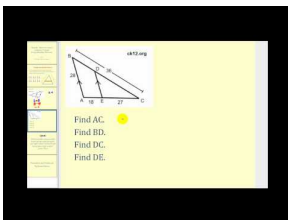

MEDIA

Click image to the left for more content.

James Sousa: Using the Triangle Proportionality Theorem to Solve for Unknown Values

Guidance

Think about a **midsegment** of a triangle. A midsegment is parallel to one side of a triangle and divides the other two sides into congruent halves. The midsegment divides those two sides **proportionally**. But what about another line

that is parallel, but does not divide the other two sides into congruent halves? In fact, such a line will still divide the sides proportionally. This is called the **Triangle Proportionality Theorem**.

Triangle Proportionality Theorem: If a line parallel to one side of a triangle intersects the other two sides, then it divides those sides proportionally.

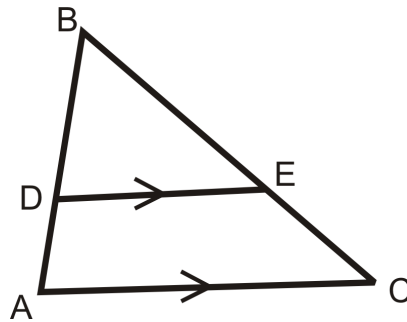

If $\overline{DE} \parallel \overline{AC}$, then $\frac{BD}{DA} = \frac{BE}{EC}$. ($\frac{DA}{BD} = \frac{EC}{BE}$ is also a true proportion.)

The converse of this theorem is also true.

Triangle Proportionality Theorem Converse: If a line divides two sides of a triangle proportionally, then it is parallel to the third side.

If $\frac{BD}{DA} = \frac{BE}{EC}$, then $\overline{DE} \parallel \overline{AC}$.

Example A

A triangle with its midsegment is drawn below. What is the ratio that the midsegment divides the sides into?

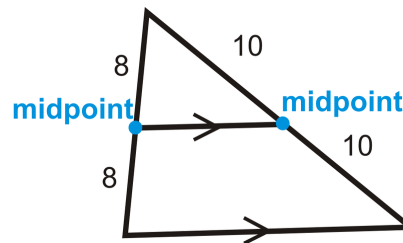

The midsegment splits the sides evenly. The ratio would be 8:8 or 10:10, which both reduce to 1:1.

Example B

In the diagram below, $\overline{EB} \parallel \overline{CD}$. Find BC .

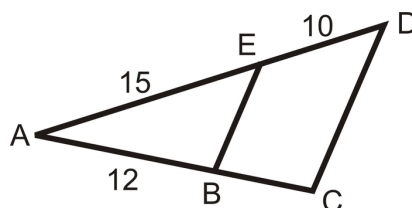

To solve, set up a proportion.

$$\frac{10}{15} = \frac{BC}{12} \rightarrow 15(BC) = 120$$

$$BC = 8$$

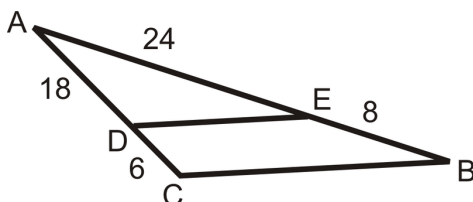
Example CIs $\overline{DE} \parallel \overline{CB}$?

If the ratios are equal, then the lines are parallel.

$$\frac{6}{18} = \frac{8}{24} = \frac{1}{3}$$

Because the ratios are equal, $\overline{DE} \parallel \overline{CB}$.**MEDIA**

Click image to the left for more content.

CK-12 Foundation: Triangle Proportionality

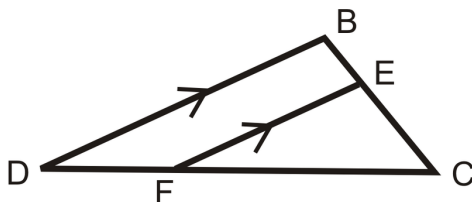
Guided PracticeUse the diagram to answer questions 1-5. $\overline{DB} \parallel \overline{FE}$.

1. Name the similar triangles. Write the similarity statement.

2. $\frac{BE}{EC} = \frac{?}{FC}$

3. $\frac{EC}{CB} = \frac{CF}{?}$

4. $\frac{DB}{?} = \frac{BC}{EC}$

5. $\frac{FC+?}{FC} = \frac{?}{FE}$

Answers:

1. $\triangle DBC \sim \triangle FEC$
2. DF
3. DC
4. FE
5. DF; DB

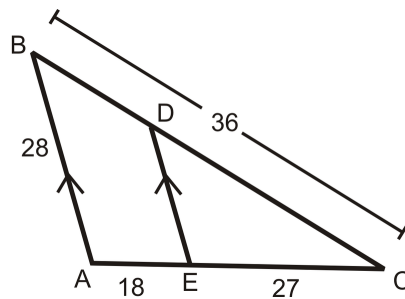
PracticeUse the diagram to answer questions 1-7. $\overline{AB} \parallel \overline{DE}$.

1. Find BD .
2. Find DC .
3. Find DE .
4. Find AC .
5. What is $BD : DC$?
6. What is $DC : BC$?
7. Why $BD : DC \neq DC : BC$?

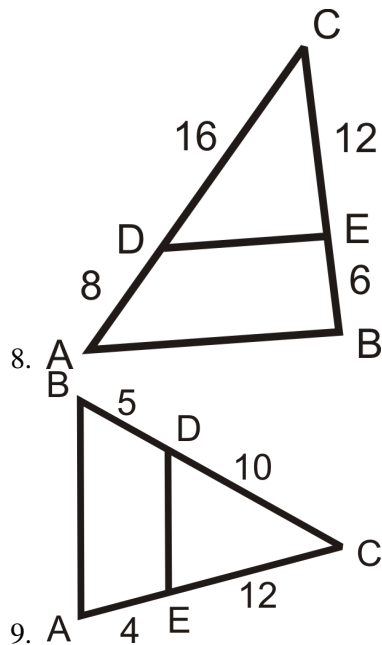
Use the given lengths to determine if $\overline{AB} \parallel \overline{DE}$.

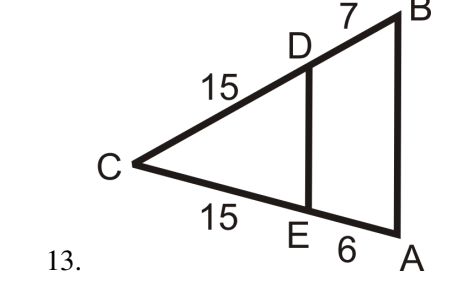
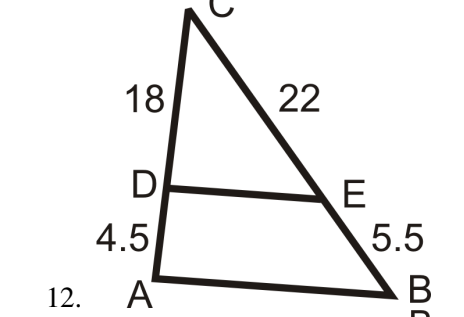
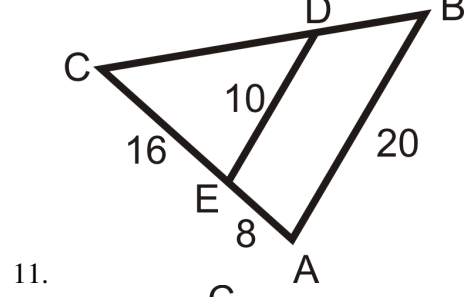
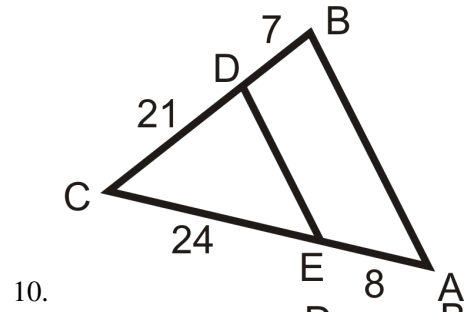

7.9 Parallel Lines and Transversals

Here you'll learn how to use the Triangle Proportionality Theorem, which states that if a line that is parallel to one side of a triangle intersects the other two sides, then it divides those sides proportionally.

What if you were looking at a map that showed four parallel streets (A, B, C, and D) cut by two avenues, or transversals, (1 and 2)? How could you determine the distance you would have to travel down Avenue 2 to reach Street C from Street B given the distance down Avenue 1 from Street A to Street B, the distance down Avenue 1 from Street B to C, and the distance down Avenue 2 from Street A to B? After completing this Concept, you'll be able to solve problems like this one.

Watch This



MEDIA

Click image to the left for more content.

[CK-12 Foundation: Parallel Lines and Transversals](#)

Guidance

The **Triangle Proportionality Theorem** states that if a line parallel to one side of a triangle intersects the other two sides, then it divides those sides proportionally. We can extend this theorem to a situation outside of triangles where we have multiple parallel lines cut by transversals.

Theorem: If two or more parallel lines are cut by two transversals, then they divide the transversals proportionally.

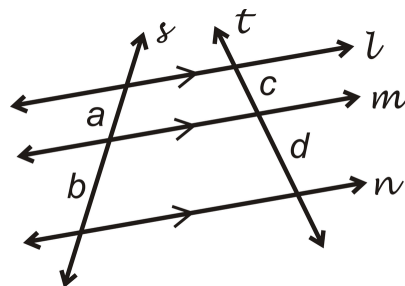

If $l \parallel m \parallel n$, then $\frac{a}{b} = \frac{c}{d}$ or $\frac{a}{c} = \frac{b}{d}$.

Note that this theorem works for **any** number of parallel lines with **any** number of transversals. When this happens, all corresponding segments of the transversals are proportional.

Example A

Find a .

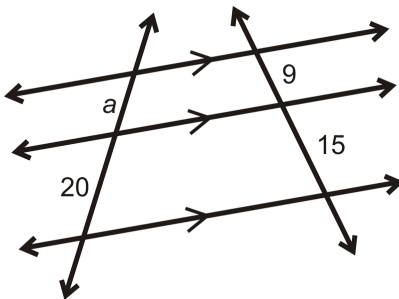

The three lines are marked parallel, so to solve, set up a proportion.

$$\begin{aligned}\frac{a}{20} &= \frac{9}{15} \\ 180 &= 15a \\ a &= 12\end{aligned}$$

Example B

Find b .

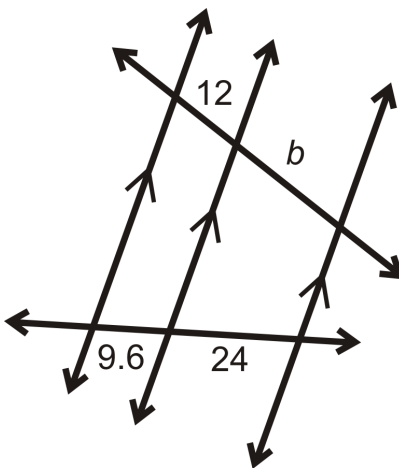

To solve, set up a proportion.

$$\begin{aligned}\frac{12}{9.6} &= \frac{b}{24} \\ 288 &= 9.6b \\ b &= 30\end{aligned}$$

Example C

Find the value of x that makes the lines parallel.

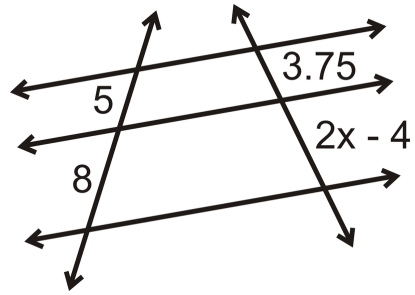

To solve, set up a proportion and solve for x .

$$\frac{5}{8} = \frac{3.75}{2x-4} \rightarrow 5(2x-4) = 8(3.75)$$

$$10x - 20 = 30$$

$$10x = 50$$

$$x = 5$$



MEDIA

Click image to the left for more content.

CK-12 Foundation: Parallel Lines and Transversals

Guided Practice

1. Find a , b , and c .

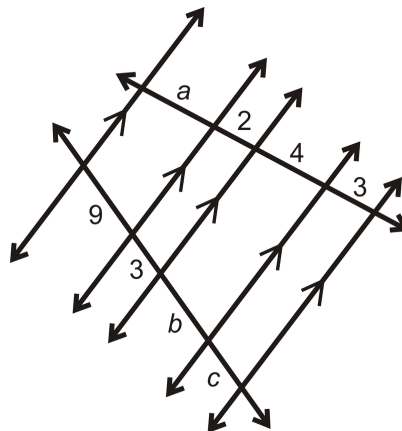

2. Below is a street map of part of Washington DC. R Street, Q Street, and O Street are parallel and 7^{th} Street is perpendicular to all three. All the measurements are given on the map. What are x and y ?

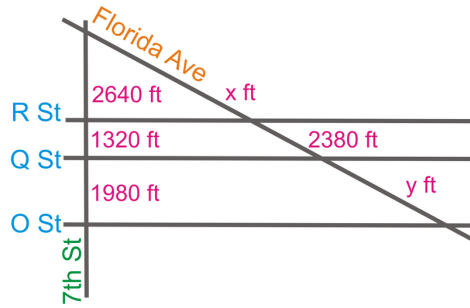

3. Find the value of a in the diagram below:

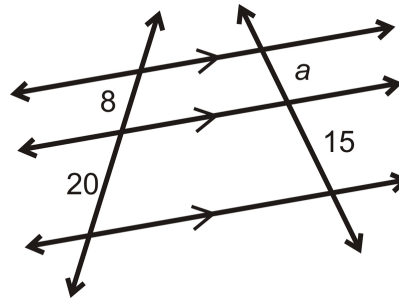

Answers:

1. Line up the segments that are opposite each other.

$\frac{a}{9} = \frac{2}{3}$	$\frac{2}{3} = \frac{4}{b}$	$\frac{2}{3} = \frac{3}{c}$
$3a = 18$	$2b = 12$	$2c = 9$
$a = 6$	$b = 6$	$c = 4.5$

2. To find x and y , you need to set up a proportion using the parallel lines.

$$\frac{2640}{x} = \frac{1320}{2380} = \frac{1980}{y}$$

From this, $x = 4760 \text{ ft}$ and $y = 3570 \text{ ft}$.

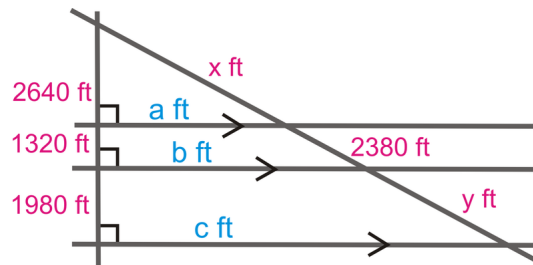

3. Set up a proportion using the parallel lines and solve the equation for a .

$$\frac{8}{20} = \frac{a}{15}$$

$$15 \cdot 8 = 20a$$

$$120 = 20a$$

$$a = 6$$

Practice

Find the value of each variable in the pictures below.

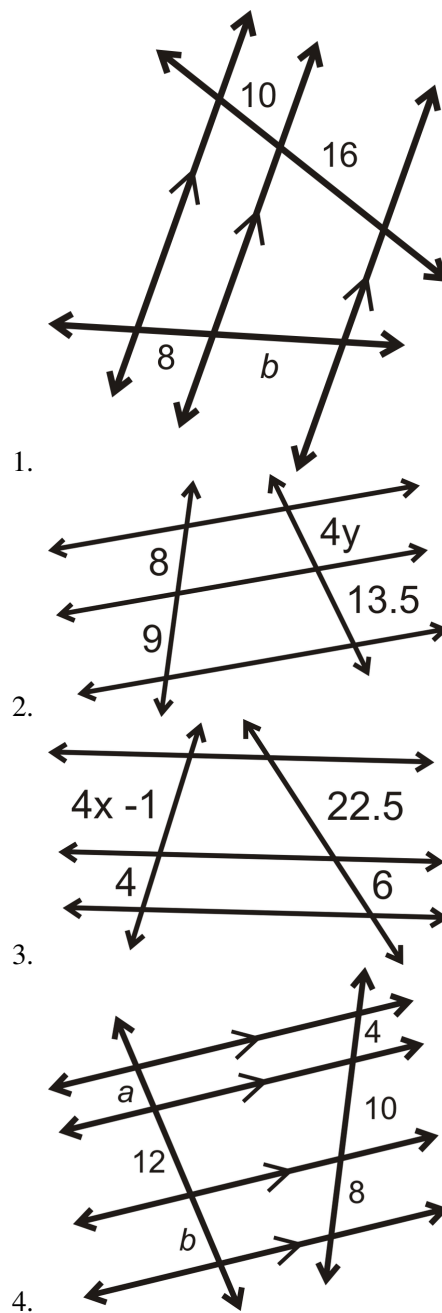

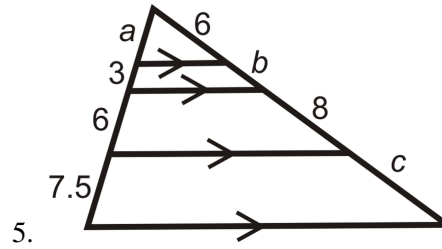

The street map shows part of New Orleans. Burgundy St., Dauphine St. and Royal St. are parallel to each other. If Spain St. is perpendicular to all three, find the indicated distances.

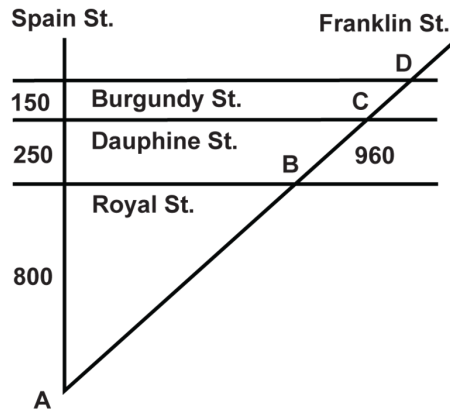

6. What is the distance between points A and B ?
7. What is the distance between points C and D ?
8. What is the distance between points A and D ?

Using the diagram, answer the questions.

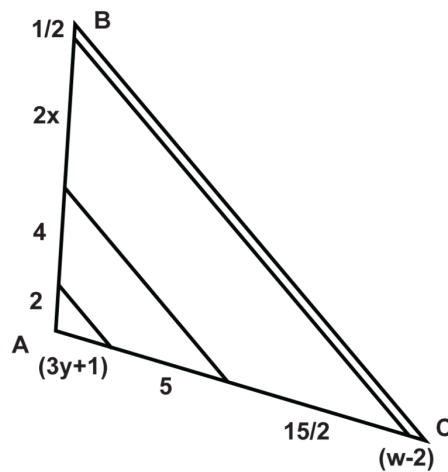

9. What is the value of w ?
10. What is the value of x ?
11. What is the value of y ?
12. What is the length of \overline{AB} ?
13. What is the length of \overline{AC} ?

Using the diagram, fill in the blank.

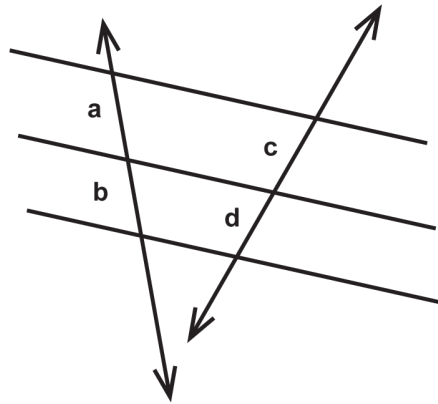

14. If b is one-third d , then a is _____.
15. If c is two times a , then b is _____.

7.10 Proportions with Angle Bisectors

Here you'll learn how to apply the Angle Bisector Theorem, which states that if a ray bisects an angle of a triangle, then it divides the opposite side into segments that are proportional to the lengths of the other two sides.

What if you were told that a ray was an angle bisector of a triangle? How would you use this fact to find unknown values regarding the triangle's side lengths? After completing this Concept, you'll be able to use the Angle Bisector Theorem to solve such problems.

Watch This



MEDIA

Click image to the left for more content.

CK-12 Foundation: Proportions with Angle Bisectors

First watch this video.

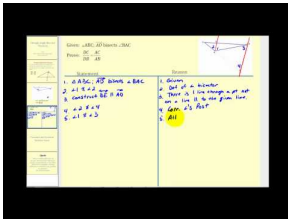

MEDIA

Click image to the left for more content.

James Sousa: Triangle Angle Bisector Theorem

Now watch this video.

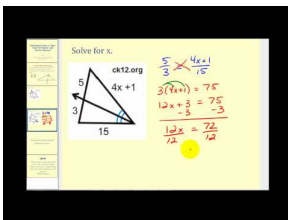

MEDIA

Click image to the left for more content.

James Sousa: Using the Triangle Angle Bisector Theorem to Determine Unknown Values

Guidance

When an angle within a triangle is bisected, the bisector divides the triangle proportionally. This idea is called the **Angle Bisector Theorem**.

Angle Bisector Theorem: If a ray bisects an angle of a triangle, then it divides the opposite side into segments that are proportional to the lengths of the other two sides.

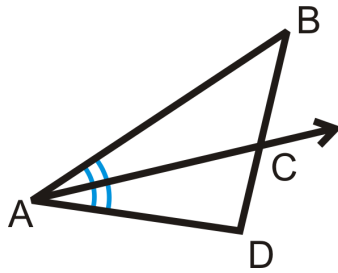

If $\triangle BAC \cong \triangle CAD$, then $\frac{BC}{CD} = \frac{AB}{AD}$.

Example A

Find x .

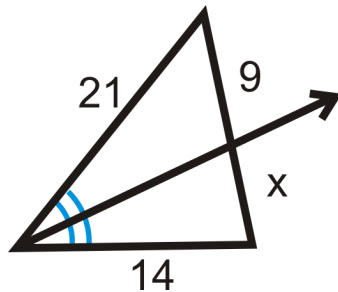

The ray is the angle bisector and it splits the opposite side in the same ratio as the other two sides. The proportion is:

$$\begin{aligned}\frac{9}{x} &= \frac{21}{14} \\ 21x &= 126 \\ x &= 6\end{aligned}$$

Example B

Find the value of x that would make the proportion true.

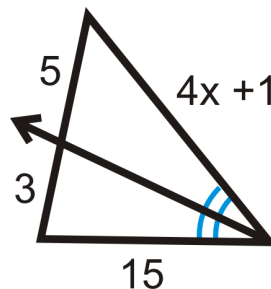

You can set up this proportion like the previous example.

$$\begin{aligned}\frac{5}{3} &= \frac{4x+1}{15} \\ 75 &= 3(4x+1) \\ 75 &= 12x+3 \\ 72 &= 12x \\ 6 &= x\end{aligned}$$

Example C

Find the missing variable:

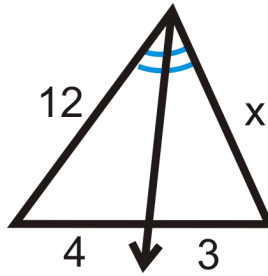

Set up a proportion and solve like in the previous examples.

$$\begin{aligned}\frac{12}{4} &= \frac{x}{3} \\ 36 &= 4x \\ x &= 9\end{aligned}$$



MEDIA

Click image to the left for more content.

[CK-12 Foundation: Proportions with Angle Bisectors](#)

Guided Practice

Find the missing variables:

1.

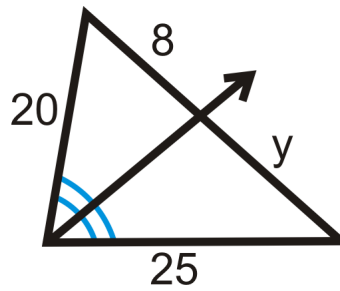

2.

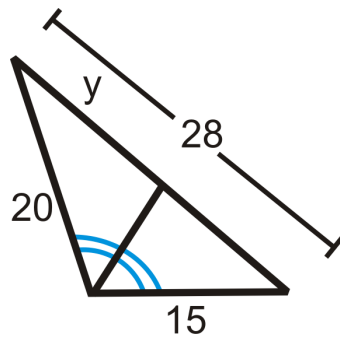

3.

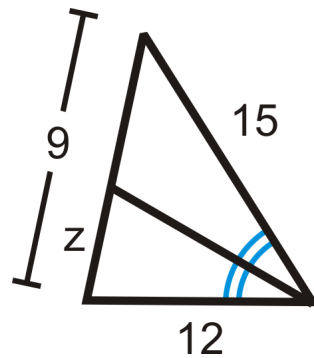
**Answers:**

1. Set up a proportion and solve.

$$\frac{20}{8} = \frac{25}{y}$$

$$20y = 200$$

$$y = 10$$

2. Set up a proportion and solve.

$$\frac{20}{y} = \frac{15}{28 - y}$$

$$15y = 20(28 - y)$$

$$15y = 560 - 20y$$

$$35y = 560$$

$$y = 16$$

3. Set up a proportion and solve.

$$\frac{12}{z} = \frac{15}{9-z}$$

$$15z = 12(9-z)$$

$$15z = 108 = 12z$$

$$27z = 108$$

$$z = 4$$

Practice

Find the value of the missing variable(s).

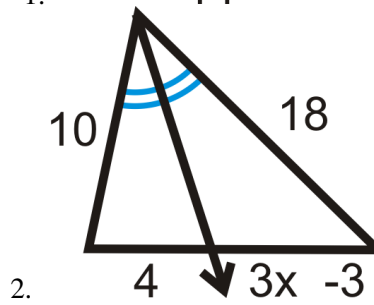
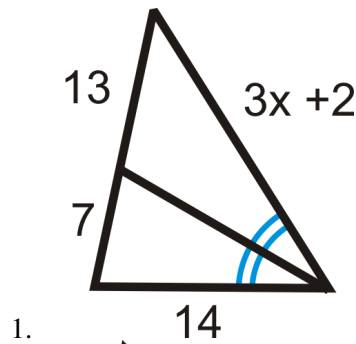

Solve for the unknown variable.

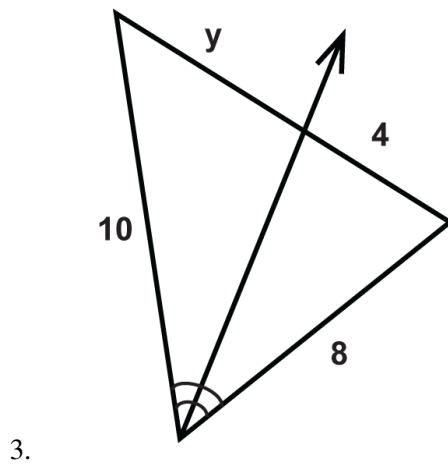

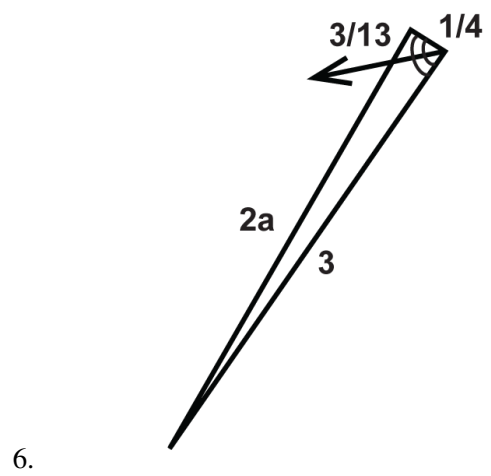
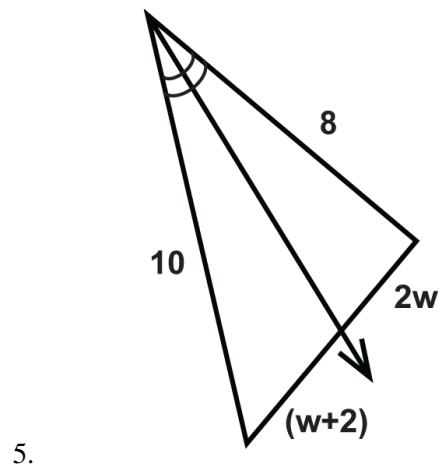
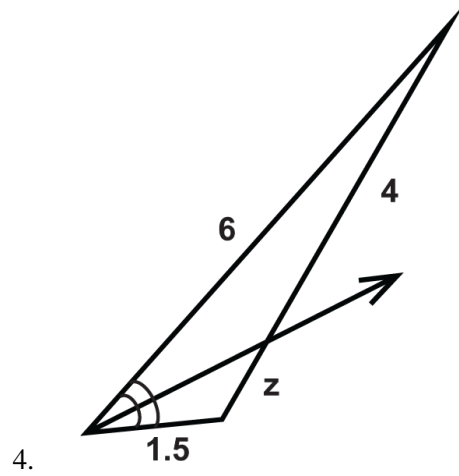

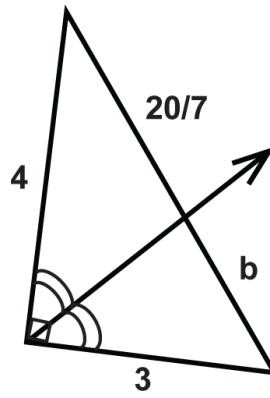

7.

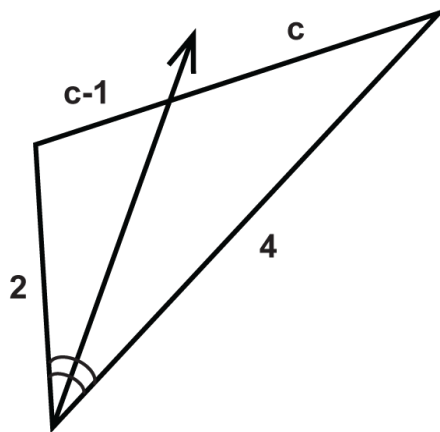

8.

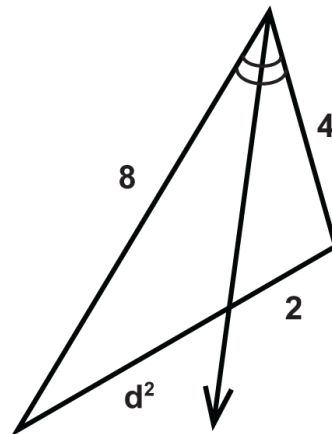

9.

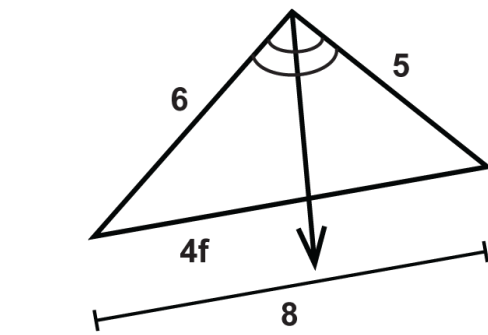
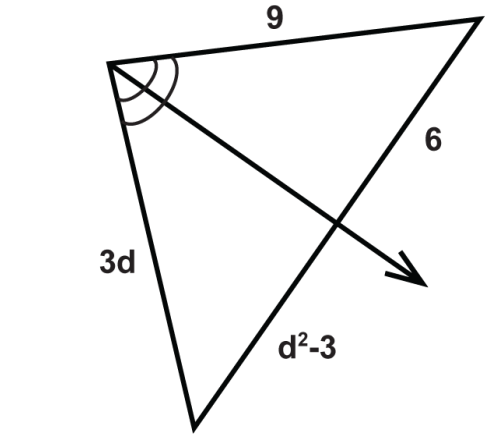
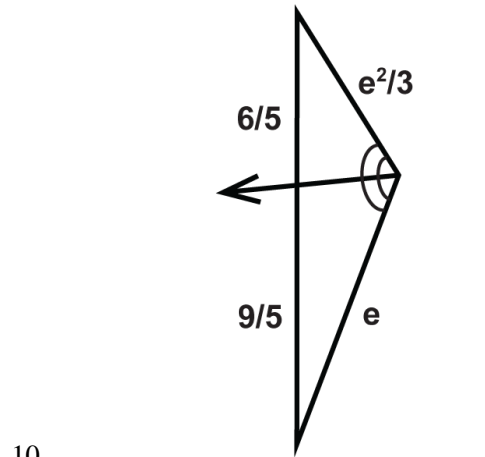

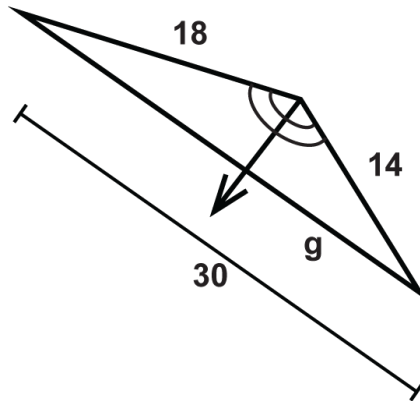

13.

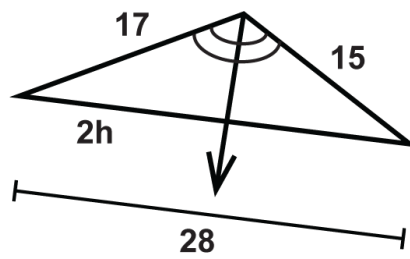

14.

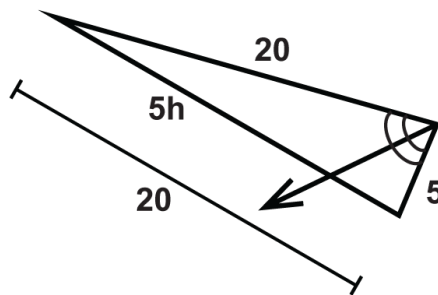

15.

7.11 Dilation

Here you'll learn what a dilation is, how to dilate a figure, and how to find the scale factor by which the figure is dilated.

What if you enlarged or reduced a triangle without changing its shape? How could you find the scale factor by which the triangle was stretched or shrunk? After completing this Concept, you'll be able to use the corresponding sides of dilated figures to solve problems like this one.

Watch This



MEDIA

Click image to the left for more content.

[CK-12 Foundation: Dilation](#)

Guidance

Two figures are similar if they are the same shape but not necessarily the same size. One way to create similar figures is by dilating. A dilation makes a figure larger or smaller but the new resulting figure has the same shape as the original.

Dilation: An enlargement or reduction of a figure that preserves shape but not size. All dilations are similar to the original figure.

Dilations have a **center** and a **scale factor**. The center is the point of reference for the dilation and the scale factor tells us how much the figure stretches or shrinks. A scale factor is labeled k . Only positive scale factors, k , will be considered in this text.

If the dilated image is smaller than the original, then $0 < k < 1$.

If the dilated image is larger than the original, then $k > 1$.

A dilation, or image, is always followed by a '.

TABLE 7.2:

<i>Label It</i>	<i>Say It</i>
'	“prime” (copy of the original)
A'	“a prime” (copy of point A)
A''	“a double prime” (second copy)

Example A

The center of dilation is P and the scale factor is 3.

Find Q' .

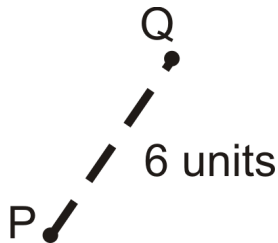

If the scale factor is 3 and Q is 6 units away from P , then Q' is going to be $6 \times 3 = 18$ units away from P . The dilated image will be on the same line as the original image and center.

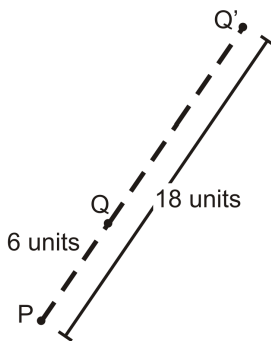

Example B

Using the picture above, change the scale factor to $\frac{1}{3}$.

Find Q'' using this new scale factor.

The scale factor is $\frac{1}{3}$, so Q'' is going to be $6 \times \frac{1}{3} = 2$ units away from P . Q'' will also be collinear with Q and center.

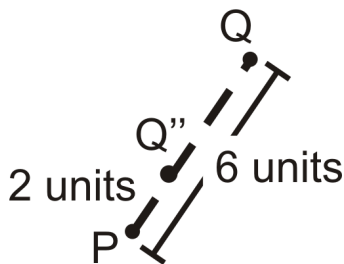

Example C

$KLMN$ is a rectangle. If the center of dilation is K and $k = 2$, draw $K'L'M'N'$.

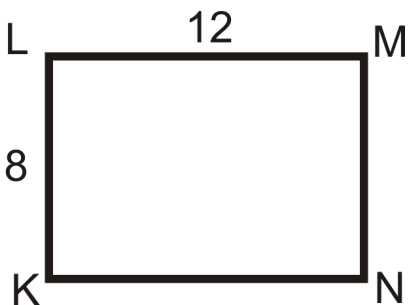

If K is the center of dilation, then K and K' will be the same point. From there, L' will be 8 units above L and N' will be 12 units to the right of N .

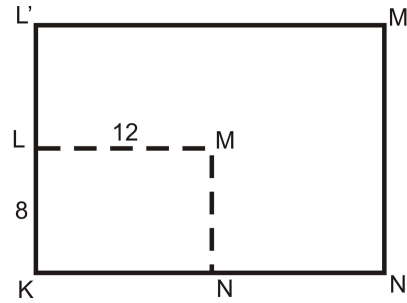

MEDIA

Click image to the left for more content.

CK-12 Foundation: Dilation

Guided Practice

1. Find the perimeters of $KLMN$ and $K'L'M'N'$. Compare this ratio to the scale factor.

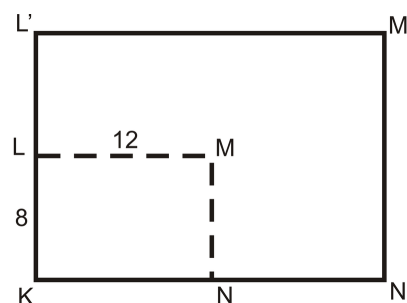
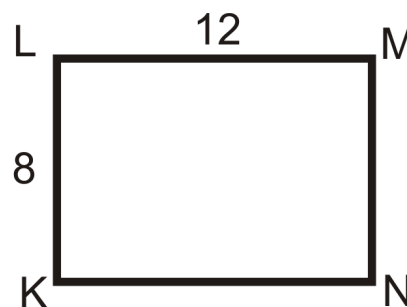

2. $\triangle ABC$ is a dilation of $\triangle DEF$. If P is the center of dilation, what is the scale factor?

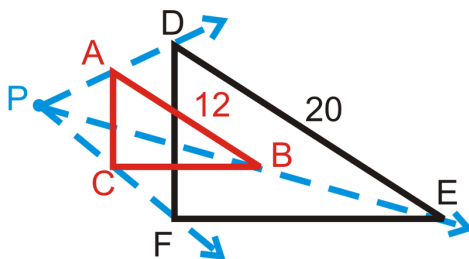

3. Find the scale factor, given the corresponding sides. In the diagram, the **black** figure is the original and *P* is the center of dilation.

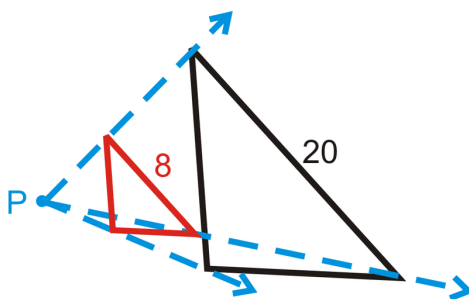

Answers:

1. The perimeter of $KLMN = 12 + 8 + 12 + 8 = 40$. The perimeter of $K'L'M'N' = 24 + 16 + 24 + 16 = 80$. The ratio is $80:40$, which reduces to $2:1$, which is the same as the scale factor.

2. Because $\triangle ABC$ is a dilation of $\triangle DEF$, then $\triangle ABC \sim \triangle DEF$. The scale factor is the ratio of the sides. Since $\triangle ABC$ is smaller than the original, $\triangle DEF$, the scale factor is going to be less than one, $\frac{12}{20} = \frac{3}{5}$.

If $\triangle DEF$ was the dilated image, the scale factor would have been $\frac{5}{3}$.

3. Since the dilation is smaller than the original, the scale factor is going to be less than one. $\frac{8}{20} = \frac{2}{5}$

Practice

For the given shapes, draw the dilation, given the scale factor and center.

- $k = 3.5$, center is *A*

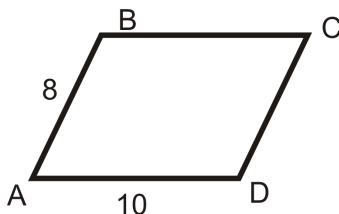

- $k = 2$, center is *D*

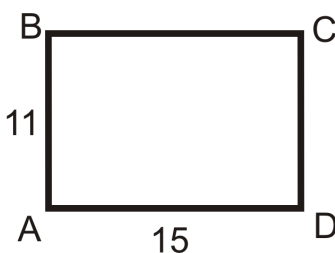

3. $k = \frac{3}{4}$, center is A

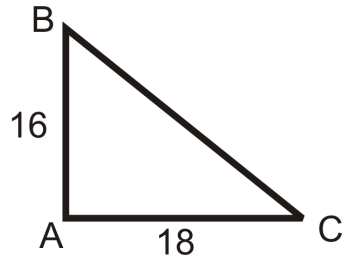

4. $k = \frac{2}{3}$, center is A

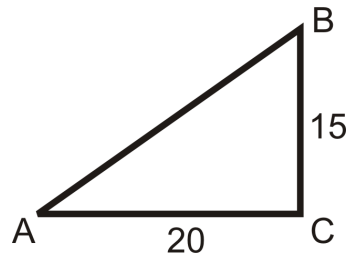

In the four questions below, you are told the scale factor. Determine the dimensions of the dilation. In each diagram, the **black** figure is the original and *P* is the center of dilation.

5. $k = 4$

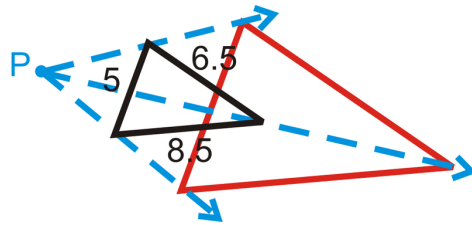

6. $k = \frac{1}{3}$

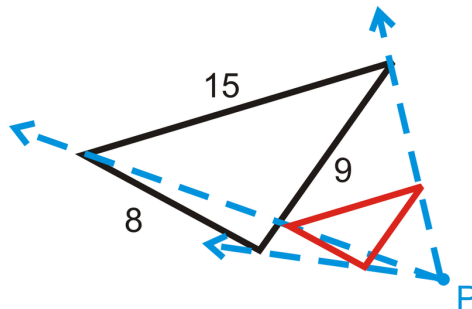

7. $k = 2.5$

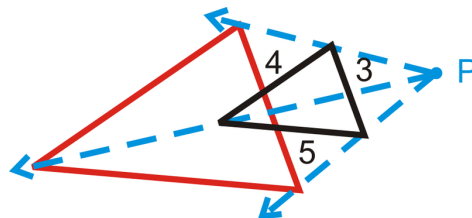

8. $k = \frac{1}{4}$

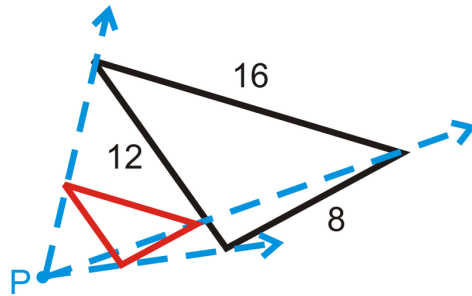

In the three questions below, find the scale factor, given the corresponding sides. In each diagram, the **black** figure is the original and P is the center of dilation.

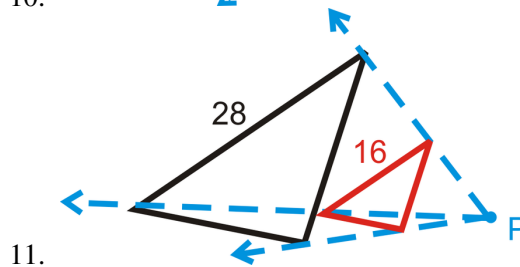
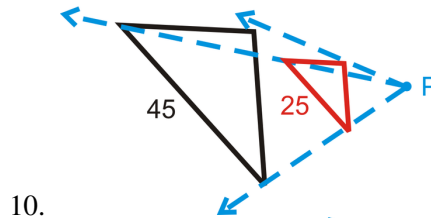
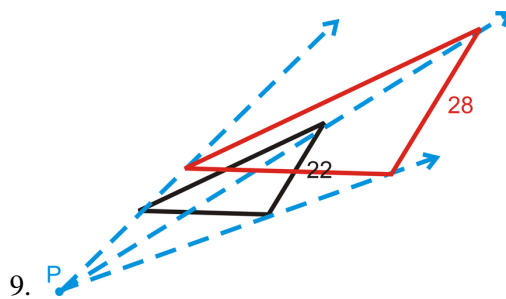

7.12 Dilation in the Coordinate Plane

Here you'll learn how to draw dilated figures in the coordinate plane given starting coordinates and the scale factor. You'll also learn how to use dilated figures in the coordinate plane to find scale factors.

What if you were given the coordinates of a figure and were asked to dilate that figure by a scale factor of 2? How could you find the coordinates of the dilated figure? After completing this Concept, you'll be able to solve problems like this one.

Watch This



MEDIA

Click image to the left for more content.

[CK-12 Foundation: Dilation in the CoordinatePlane](#)

Guidance

Two figures are similar if they are the same shape but not necessarily the same size. One way to create similar figures is by dilating. A dilation makes a figure larger or smaller such that the new image has the same shape as the original.

Dilation: An enlargement or reduction of a figure that preserves shape but not size. All dilations are similar to the original figure.

Dilations have a **center** and a **scale factor**. The center is the point of reference for the dilation and the scale factor tells us how much the figure stretches or shrinks. A scale factor is labeled k . Only positive scale factors, k , will be considered in this text.

If the dilated image is smaller than the original, then $0 < k < 1$.

If the dilated image is larger than the original, then $k > 1$.

To dilate something in the coordinate plane, multiply each coordinate by the scale factor. This is called **mapping**. For any dilation the mapping will be $(x, y) \rightarrow (kx, ky)$. In this text, the center of dilation will always be the origin.

Example A

Quadrilateral $EFGH$ has vertices $E(-4, -2)$, $F(1, 4)$, $G(6, 2)$ and $H(0, -4)$. Draw the dilation with a scale factor of 1.5.

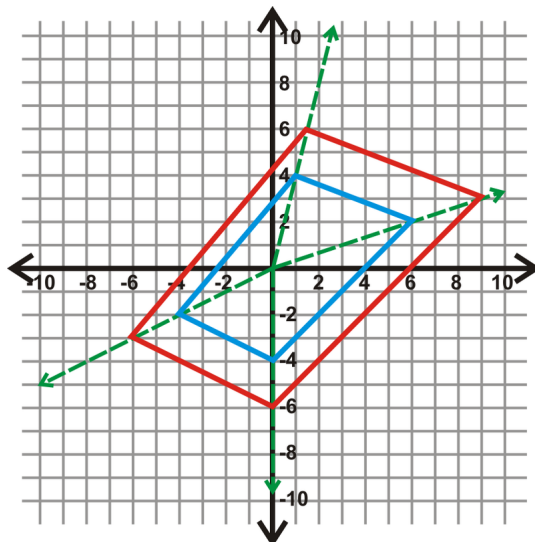

Remember that to dilate something in the coordinate plane, multiply each coordinate by the scale factor.

For this dilation, the mapping will be $(x, y) \rightarrow (1.5x, 1.5y)$.

$$E(-4, -2) \rightarrow (1.5(-4), 1.5(-2)) \rightarrow E'(-6, -3)$$

$$F(1, 4) \rightarrow (1.5(1), 1.5(4)) \rightarrow F'(1.5, 6)$$

$$G(6, 2) \rightarrow (1.5(6), 1.5(2)) \rightarrow G'(9, 3)$$

$$H(0, -4) \rightarrow (1.5(0), 1.5(-4)) \rightarrow H'(0, -6)$$

In the graph above, the blue quadrilateral is the original and the red image is the dilation.

Example B

Determine the coordinates of $\triangle ABC$ and $\triangle A'B'C'$ and find the scale factor.

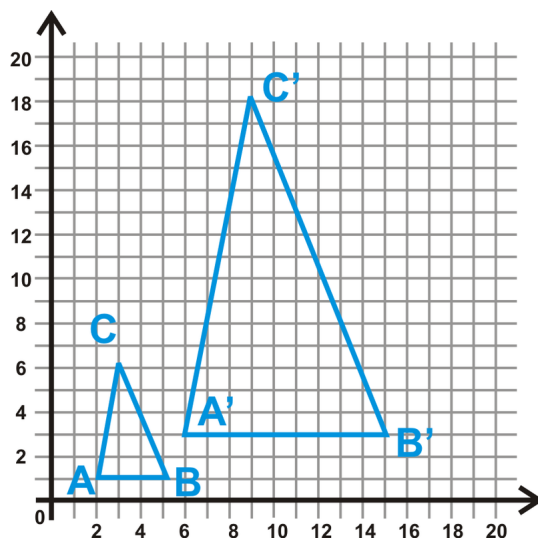

The coordinates of the vertices of $\triangle ABC$ are $A(2, 1)$, $B(5, 1)$ and $C(3, 6)$. The coordinates of the vertices of $\triangle A'B'C'$ are $A'(6, 3)$, $B'(15, 3)$ and $C'(9, 18)$. Each of the corresponding coordinates are three times the original, so $k = 3$.

Example C

Show that dilations preserve shape by using the distance formula. Find the lengths of the sides of both triangles in Example B.

$$\begin{array}{ll} \triangle ABC & \triangle A'B'C' \\ AB = \sqrt{(2-5)^2 + (1-1)^2} = \sqrt{9} = 3 & A'B' = \sqrt{(6-15)^2 + (3-3)^2} = \sqrt{81} = 9 \\ AC = \sqrt{(2-3)^2 + (1-6)^2} = \sqrt{26} & A'C' = \sqrt{(6-9)^2 + (3-18)^2} = \sqrt{234} = 3\sqrt{26} \\ CB = \sqrt{(3-5)^2 + (6-1)^2} = \sqrt{29} & C'B' = \sqrt{(9-15)^2 + (18-3)^2} = \sqrt{261} = 3\sqrt{29} \end{array}$$

From this, we also see that all the sides of $\triangle A'B'C'$ are three times larger than $\triangle ABC$.



MEDIA

Click image to the left for more content.

[CK-12 Foundation: Dilation in the CoordinatePlane](#)

Guided Practice

Given A and the scale factor, determine the coordinates of the dilated point, A' . You may assume the center of dilation is the origin.

1. $A(3,9), k = \frac{2}{3}$
2. $A(-4,6), k = 2$
3. $A(9,-13), k = \frac{1}{2}$

Answers

Remember that the mapping will be $(x,y) \rightarrow (kx,ky)$.

1. $A'(2,6)$
2. $A'(-8,12)$
3. $A'(4.5,-6.5)$

Practice

Given A and A' , find the scale factor. You may assume the center of dilation is the origin.

1. $A(8,2), A'(12,3)$
2. $A(-5,-9), A'(-45,-81)$
3. $A(22,-7), A(11,-3.5)$

The origin is the center of dilation. Draw the dilation of each figure, given the scale factor.

4. $A(2,4), B(-3,7), C(-1,-2); k = 3$
5. $A(12,8), B(-4,-16), C(0,10); k = \frac{3}{4}$

Multi-Step Problem Questions 6-9 build upon each other.

6. Plot $A(1,2), B(12,4), C(10,10)$. Connect to form a triangle.
7. Make the origin the center of dilation. Draw 4 rays from the origin to each point from #21. Then, plot $A'(2,4), B'(24,8), C'(20,20)$. What is the scale factor?
8. Use $k = 4$, to find $A''B''C''$. Plot these points.
9. What is the scale factor from $A'B'C'$ to $A''B''C''$?

If O is the origin, find the following lengths (using 6-9 above). Round all answers to the nearest hundredth.

10. OA
11. AA'
12. AA''
13. OA'
14. OA''
15. AB
16. $A'B'$
17. $A''B''$
18. Compare the ratios $OA : OA'$ and $AB : A'B'$. What do you notice? Why do you think that is?
19. Compare the ratios $OA : OA''$ and $AB : A''B''$. What do you notice? Why do you think that is?

7.13 Self-Similarity

Here you'll learn what it means for an object to be self-similar and you'll be introduced to some common examples of self-similarity.

What if you were given an object, like a triangle or a snowflake, in which a part of it could be enlarged (or shrunk) to look like the whole object? What would each successive iteration of that object look like? After completing this Concept, you'll be able to use the idea of self-similarity to answer questions like this one.

Watch This



MEDIA

Click image to the left for more content.

[CK-12 Foundation: Self-Similarity](#)

Guidance

When one part of an object can be enlarged (or shrunk) to look like the whole object it is **self-similar**.

To explore self-similarity, we will go through some examples. Typically, each step of a process is called an *iteration*. The first level is called *Stage 0*.

Example A (Sierpinski Triangle)

The Sierpinski triangle iterates a triangle by connecting the midpoints of the sides and shading the central triangle (Stage 1). Repeat this process for the unshaded triangles in Stage 1 to get Stage 2.

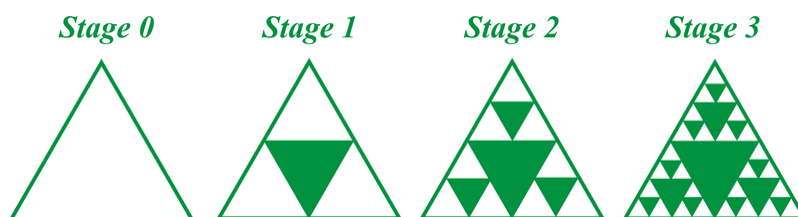

Example B (Fractals)

Like the Sierpinski triangle, a fractal is another self-similar object that is repeated at smaller scales. Below are the first three stages of the Koch snowflake.



Example C (The Cantor Set)

The Cantor set is another example of a fractal. It consists of dividing a segment into thirds and then erasing the middle third.

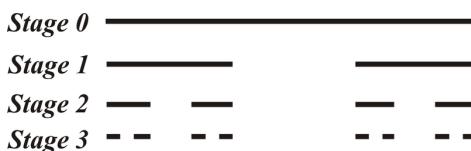

MEDIA

Click image to the left for more content.

[CK-12 Foundation: Self-Similarity](#)

Guided Practice

- Determine the number of edges and the perimeter of each snowflake shown in Example B. Assume that the length of one side of the original (stage 0) equilateral triangle is 1.
- Determine the number of shaded and unshaded triangles in each stage of the Sierpinski triangle. Determine if there is a pattern.
- Determine the number of segments in each stage of the Cantor Set. Is there a pattern?

Answers:

1.

TABLE 7.3:

	<i>Stage 0</i>	<i>Stage 1</i>	<i>Stage 2</i>
<i>Number of Edges</i>	3	12	48
<i>Edge Length</i>	1	$\frac{1}{3}$	$\frac{1}{9}$
<i>Perimeter</i>	3	4	$\frac{48}{9} = \frac{15}{3}$

2.

TABLE 7.4:

	<i>Stage 0</i>	<i>Stage 1</i>	<i>Stage 2</i>	<i>Stage 3</i>
<i>Unshaded</i>	1	3	9	27

TABLE 7.4: (continued)

<i>Shaded</i>	<i>Stage 0</i>	<i>Stage 1</i>	<i>Stage 2</i>	<i>Stage 3</i>
	0	1	4	13

The number of unshaded triangles seems to be powers of 3 : $3^0, 3^1, 3^2, 3^3, \dots$. The number of shaded triangles is the sum the the number of shaded and unshaded triangles from the previous stage. For Example, the number of shaded triangles in Stage 4 would equal $27 + 13 = 40$.

3. Starting from Stage 0, the number of segments is 1, 2, 4, 8, 16, \dots . These are the powers of 2. $2^0, 2^1, 2^2, \dots$

Practice

1. Draw Stage 4 of the Cantor set.
2. Use the Cantor Set to fill in the table below.

TABLE 7.5:

	<i>Number of Segments</i>	<i>Length of each Segment</i>	<i>Total Length of the Segments</i>
<i>Stage 0</i>	1	1	1
<i>Stage 1</i>	2	$\frac{1}{3}$	$\frac{2}{3}$
<i>Stage 2</i>	4	$\frac{1}{9}$	$\frac{4}{9}$
<i>Stage 3</i>			
<i>Stage 4</i>			
<i>Stage 5</i>			

3. How many segments are in Stage n ?
4. Draw Stage 3 of the Koch snowflake.
5. A variation on the Sierpinski triangle is the Sierpinski carpet, which splits a square into 9 equal squares, coloring the middle one only. Then, split the uncolored squares to get the next stage. Draw the first 3 stages of this fractal.
6. How many colored vs. uncolored square are in each stage?
7. Fractals are very common in nature. For example, a fern leaf is a fractal. As the leaves get closer to the end, they get smaller and smaller. Find three other examples of fractals in nature.



Summary

This chapter is all about proportional relationships. It begins by introducing the concept of ratio and proportion and detailing properties of proportions. It then takes these arithmetic and algebraic relationships and connects them to the geometric relationships of similar polygons. Applications of similar polygons and scale factors are covered. The AA, SSS, and SAS methods of determining similar triangles are presented and the Triangle Proportionality Theorem is explored. The chapter wraps up with the proportional relationships formed when parallel lines are cut by a transversal, similarity and dilated figures, and self-similarity.

CHAPTER 8 Right Triangle Trigonometry

Chapter Outline

- 8.1 EXPRESSIONS WITH RADICALS
 - 8.2 PYTHAGOREAN THEOREM AND PYTHAGOREAN TRIPLES
 - 8.3 APPLICATIONS OF THE PYTHAGOREAN THEOREM
 - 8.4 INSCRIBED SIMILAR TRIANGLES
 - 8.5 45-45-90 RIGHT TRIANGLES
 - 8.6 30-60-90 RIGHT TRIANGLES
 - 8.7 SINE, COSINE, TANGENT
 - 8.8 TRIGONOMETRIC RATIOS WITH A CALCULATOR
 - 8.9 TRIGONOMETRY WORD PROBLEMS
 - 8.10 INVERSE TRIGONOMETRIC RATIOS
-

Introduction

This chapter takes a look at right triangles. A right triangle is a triangle with exactly one right angle. In this chapter, we will prove the Pythagorean Theorem and its converse. Then, we will discuss trigonometry ratios and inverse ratios.

8.1 Expressions with Radicals

Here you'll learn how to simplify expressions containing radicals.

What if you were asked to find the sum of $\sqrt{32}$ and $3\sqrt{8}$? How could you combine these two terms so that you could add them? After completing this lesson, you'll be able to simplify radical terms and expressions like these.

Watch This



MEDIA

Click image to the left for more content.

[CK-12 Foundation: Simplifying Radicals Review](#)

Guidance

In algebra, you learned how to simplify radicals. Let's review it here. Some key points to remember:

1. One way to simplify a radical is to factor out the perfect squares (see Example A).
2. When adding radicals, you can only combine radicals with the same number underneath it. For example, $2\sqrt{5} + 3\sqrt{6}$ cannot be combined, because 5 and 6 are not the same number (see Example B).
3. To multiply two radicals, multiply what is under the radicals and what is in front (see Example B).
4. To divide radicals, you need to simplify the denominator, which means multiplying the top and bottom of the fraction by the radical in the denominator (see Example C).

Example A

Simplify the radicals.

a) $\sqrt{50}$

b) $\sqrt{27}$

c) $\sqrt{272}$

Answers: For each radical, find the square number(s) that are factors.

a) $\sqrt{50} = \sqrt{25 \cdot 2} = 5\sqrt{2}$

b) $\sqrt{27} = \sqrt{9 \cdot 3} = 3\sqrt{3}$

c) $\sqrt{272} = \sqrt{16 \cdot 17} = 4\sqrt{17}$

Example B

Simplify the radicals.

a) $2\sqrt{10} + \sqrt{160}$

b) $5\sqrt{6} \cdot 4\sqrt{18}$

c) $\sqrt{8} \cdot 12\sqrt{2}$

d) $(5\sqrt{2})^2$

Answers:

a) Simplify $\sqrt{160}$ before adding: $2\sqrt{10} + \sqrt{160} = 2\sqrt{10} + \sqrt{16 \cdot 10} = 2\sqrt{10} + 4\sqrt{10} = 6\sqrt{10}$

b) $5\sqrt{6} \cdot 4\sqrt{18} = 5 \cdot 4 \sqrt{6 \cdot 18} = 20\sqrt{108} = 20\sqrt{36 \cdot 3} = 20 \cdot 6\sqrt{3} = 120\sqrt{3}$

c) $\sqrt{8} \cdot 12\sqrt{2} = 12\sqrt{8 \cdot 2} = 12\sqrt{16} = 12 \cdot 4 = 48$

d) $(5\sqrt{2})^2 = 5^2 (\sqrt{2})^2 = 25 \cdot 2 = 50 \rightarrow$ the $\sqrt{\quad}$ and the 2 cancel each other out

Example C

Divide and simplify the radicals.

a) $4\sqrt{6} \div \sqrt{3}$

b) $\frac{\sqrt{30}}{\sqrt{8}}$

c) $\frac{8\sqrt{2}}{6\sqrt{7}}$

Answers: Rewrite all division problems like a fraction.

a)

$$4\sqrt{6} \div \sqrt{3} = \frac{4\sqrt{6}}{\sqrt{3}} \cdot \frac{\sqrt{3}}{\sqrt{3}} = \frac{4\sqrt{18}}{\sqrt{9}} = \frac{4\sqrt{9 \cdot 2}}{3} = \frac{4 \cdot 3\sqrt{2}}{3} = 4\sqrt{2}$$

\rightarrow like multiplying by 1, $\frac{\sqrt{3}}{\sqrt{3}}$ does not change the value of the fraction

b) $\frac{\sqrt{30}}{\sqrt{8}} \cdot \frac{\sqrt{8}}{\sqrt{8}} = \frac{\sqrt{240}}{\sqrt{64}} = \frac{\sqrt{16 \cdot 15}}{8} = \frac{4\sqrt{15}}{8} = \frac{\sqrt{15}}{2}$

c) $\frac{8\sqrt{2}}{6\sqrt{7}} \cdot \frac{\sqrt{7}}{\sqrt{7}} = \frac{8\sqrt{14}}{6 \cdot 7} = \frac{4\sqrt{14}}{3 \cdot 7} = \frac{4\sqrt{14}}{21}$

Notice, we do not really “divide” radicals, but get them out of the denominator of a fraction.

**MEDIA**

Click image to the left for more content.

CK-12 Foundation: Simplifying Radicals Review

Guided Practice

Simplify the radicals.

1. $\sqrt{75}$

2. $2\sqrt{5} + 3\sqrt{80}$

3. $\frac{\sqrt{45}}{\sqrt{2}}$

Answers:

1. $\sqrt{75} = \sqrt{25 \cdot 3} = 5\sqrt{3}$

2. $2\sqrt{5} + 3\sqrt{80} = 2\sqrt{5} + 3(\sqrt{16 \cdot 5}) = 2\sqrt{5} + (3 \cdot 4)\sqrt{5} = 14\sqrt{5}$

3. $\frac{\sqrt{45}}{\sqrt{2}} \cdot \frac{\sqrt{2}}{\sqrt{2}} = \frac{\sqrt{90}}{\sqrt{4}} = \frac{\sqrt{9 \cdot 10}}{2} = \frac{3\sqrt{10}}{2}$

Practice

Simplify the radicals.

1. $\sqrt{48}$

2. $2\sqrt{5} + \sqrt{20}$

3. $\sqrt{24}$

4. $(6\sqrt{3})^2$

5. $8\sqrt{8} \cdot \sqrt{10}$

6. $(2\sqrt{30})^2$

7. $\sqrt{320}$

8. $\frac{4\sqrt{5}}{\sqrt{6}}$

9. $\frac{12}{\sqrt{10}}$

10. $\frac{21\sqrt{5}}{9\sqrt{15}}$

8.2 Pythagorean Theorem and Pythagorean Triples

Here you'll learn how to use the Pythagorean Theorem, which states that given a right triangle with legs of lengths a and b and a hypotenuse of length c , $a^2 + b^2 = c^2$. You'll also learn the theorem's converse and what a Pythagorean Triple is.

What if you were told that a triangle had side lengths of 5, 12, and 13? How could you determine if the triangle were a right one? After completing this Concept, you'll be able to use the Pythagorean Theorem to solve problems like this one.

Watch This



MEDIA

Click image to the left for more content.

CK-12 Foundation: Using The Pythagorean Theorem

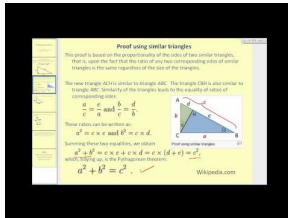

MEDIA

Click image to the left for more content.

James Sousa:PythagoreanTheorem

Guidance

The two shorter sides of a right triangle (the sides that form the right angle) are the **legs** and the longer side (the side opposite the right angle) is the **hypotenuse**. For the Pythagorean Theorem, the legs are “ a ” and “ b ” and the hypotenuse is “ c ”.

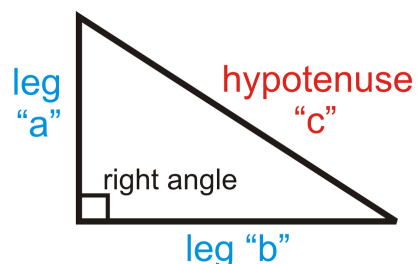

Pythagorean Theorem: Given a right triangle with legs of lengths a and b and a hypotenuse of length c , $a^2 + b^2 = c^2$.

For proofs of the Pythagorean Theorem go to: <http://www.mathsisfun.com/pythagoras.html> and scroll down to “And You Can Prove the Theorem Yourself.”

The converse of the Pythagorean Theorem is also true. It allows you to prove that a triangle is a right triangle even if you do not know its angle measures.

Pythagorean Theorem Converse: If the square of the longest side of a triangle is equal to the sum of the squares of the other two sides, then the triangle is a right triangle.

If $a^2 + b^2 = c^2$, then $\triangle ABC$ is a right triangle.

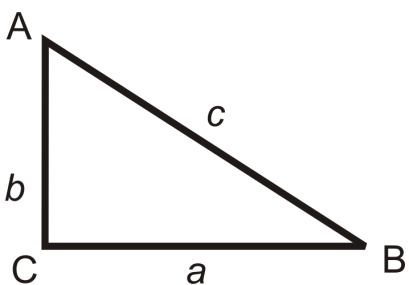

Pythagorean Triples

A combination of three numbers that makes the Pythagorean Theorem true is called a **Pythagorean triple**. Each set of numbers below is a Pythagorean triple.

3, 4, 5

5, 12, 13

7, 24, 25

8, 15, 17

9, 12, 15

10, 24, 26

Any multiple of a Pythagorean triple is also considered a Pythagorean triple. Multiplying 3, 4, 5 by 2 gives 6, 8, 10, which is another triple. To see if a set of numbers makes a Pythagorean triple, plug them into the Pythagorean Theorem.

Example A

Do 6, 7, and 8 make the sides of a right triangle?

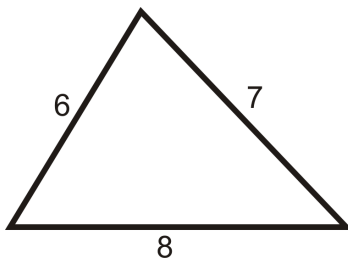

Plug the three numbers into the Pythagorean Theorem. Remember that the largest length will always be the hypotenuse, c . If $6^2 + 7^2 = 8^2$, then they are the sides of a right triangle.

$$6^2 + 7^2 = 36 + 49 = 85$$

$$8^2 = 64$$

$85 \neq 64$, so the lengths are not the sides of a right triangle.

Example B

Find the length of the hypotenuse.

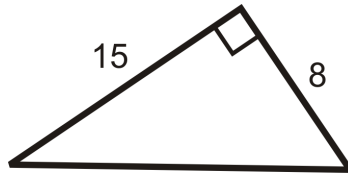

Use the Pythagorean Theorem. Set $a = 8$ and $b = 15$. Solve for c .

$$8^2 + 15^2 = c^2$$

$$64 + 225 = c^2$$

$$289 = c^2$$

$$17 = c$$

Take the square root of both sides.

Example C

Is 20, 21, 29 a Pythagorean triple?

If $20^2 + 21^2 = 29^2$, then the set is a Pythagorean triple.

$$20^2 + 21^2 = 400 + 441 = 841$$

$$29^2 = 841$$

Therefore, 20, 21, and 29 is a Pythagorean triple.

Example D

Determine if the triangles below are right triangles.

a)

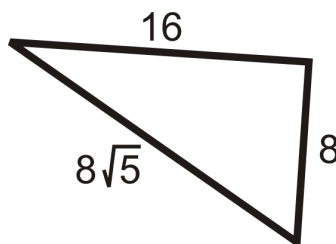

b)

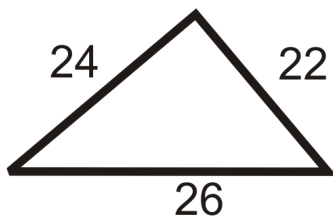

Check to see if the three lengths satisfy the Pythagorean Theorem. Let the longest side represent c .

a)

$$a^2 + b^2 = c^2$$

$$8^2 + 16^2 \stackrel{?}{=} (8\sqrt{5})^2$$

$$64 + 256 \stackrel{?}{=} 64 \cdot 5$$

$$320 = 320 \quad \text{Yes}$$

b)

$$a^2 + b^2 = c^2$$

$$22^2 + 24^2 \stackrel{?}{=} 26^2$$

$$484 + 576 \stackrel{?}{=} 676$$

$$1060 \neq 676 \quad \text{No}$$



MEDIA

Click image to the left for more content.

[CK-12 Foundation: Using The Pythagorean Theorem](#)

Guided Practice

1. Find the missing side of the right triangle below.

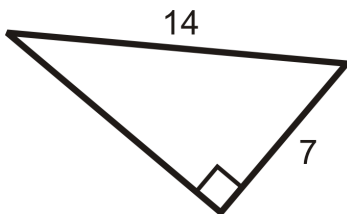

2. What is the diagonal of a rectangle with sides 10 and 16?

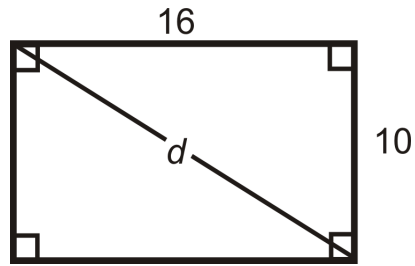

3. Do the following lengths make a right triangle?

- a) $\sqrt{5}, 3, \sqrt{14}$
 b) $6, 2\sqrt{3}, 8$
 c) $3\sqrt{2}, 4\sqrt{2}, 5\sqrt{2}$

Answers:

1. Here, we are given the hypotenuse and a leg. Let's solve for b .

$$\begin{aligned} 7^2 + b^2 &= 14^2 \\ 49 + b^2 &= 196 \\ b^2 &= 147 \\ b &= \sqrt{147} = \sqrt{49 \cdot 3} = 7\sqrt{3} \end{aligned}$$

2. For any square and rectangle, you can use the Pythagorean Theorem to find the length of a diagonal. Plug in the sides to find d .

$$\begin{aligned} 10^2 + 16^2 &= d^2 \\ 100 + 256 &= d^2 \\ 356 &= d^2 \\ d &= \sqrt{356} = 2\sqrt{89} \approx 18.87 \end{aligned}$$

3. Even though there is no picture, you can still use the Pythagorean Theorem. Again, the longest length will be c .

a)

$$\begin{aligned} (\sqrt{5})^2 + 3^2 &= \sqrt{14}^2 \\ 5 + 9 &= 14 \\ \text{Yes} \end{aligned}$$

b)

$$\begin{aligned} 6^2 + (2\sqrt{3})^2 &= 8^2 \\ 36 + (4 \cdot 3) &= 64 \\ 36 + 12 &\neq 64 \end{aligned}$$

c) This is a multiple of $\sqrt{2}$ of a 3, 4, 5 right triangle. Yes, this is a right triangle.

Practice

Find the length of the missing side. Simplify all radicals.

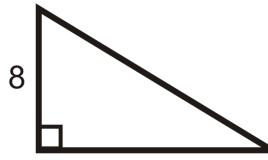

1.

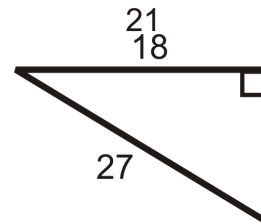

2.

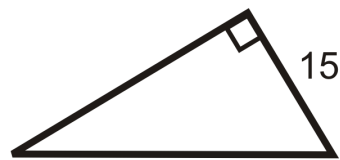

3.

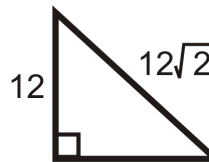

4.

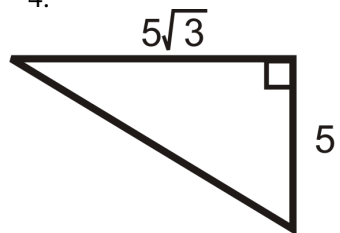

5.

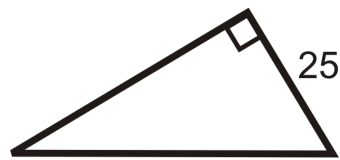

6.

7. If the legs of a right triangle are 10 and 24, then the hypotenuse is _____.
8. If the sides of a rectangle are 12 and 15, then the diagonal is _____.
9. If the sides of a square are 16, then the diagonal is _____.
10. If the sides of a square are 9, then the diagonal is _____.

Determine if the following sets of numbers are Pythagorean Triples.

11. 12, 35, 37
12. 9, 17, 18
13. 10, 15, 21
14. 11, 60, 61
15. 15, 20, 25

16. 18, 73, 75

Determine if the following lengths make a right triangle.

17. 7, 24, 25

18. $\sqrt{5}$, $2\sqrt{10}$, $3\sqrt{5}$

19. $2\sqrt{3}$, $\sqrt{6}$, 8

20. 15, 20, 25

21. 20, 25, 30

22. $8\sqrt{3}$, 6, $2\sqrt{39}$

8.3 Applications of the Pythagorean Theorem

Here you'll learn how to use the Pythagorean Theorem to find the altitude of an isosceles triangle and to determine if a triangle is acute, obtuse, or right.

What if you were given an equilateral triangle in which all the sides measured 4 inches? How could you use the Pythagorean Theorem to find the triangle's altitude? After completing this Concept, you'll be able to solve problems like this one.

Watch This



MEDIA

Click image to the left for more content.

CK-12 Foundation: Applications of the Pythagorean Theorem

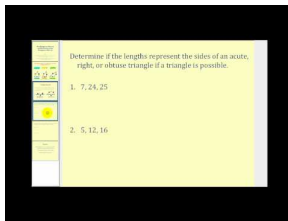

MEDIA

Click image to the left for more content.

James Sousa:PythagoreanTheoremAndItsConverse

Guidance

Find the Height of an Isosceles Triangle

One way to use The Pythagorean Theorem is to find the height of an isosceles triangle (see Example A).

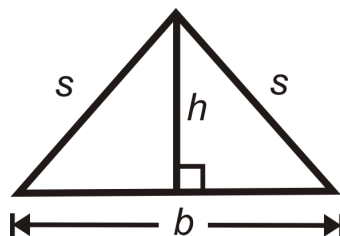

Prove the Distance Formula

Another application of the Pythagorean Theorem is the Distance Formula. We will prove it here.

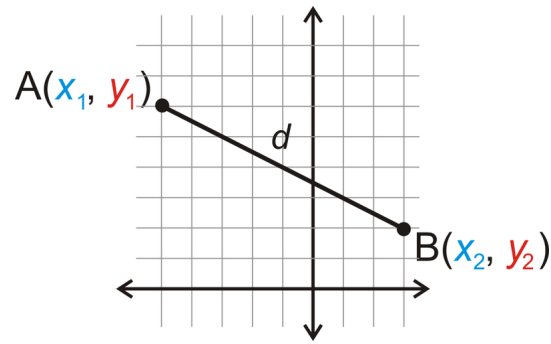

Let's start with point $A(x_1, y_1)$ and point $B(x_2, y_2)$. We will call the distance between A and B , d .

Draw the vertical and horizontal lengths to make a right triangle.

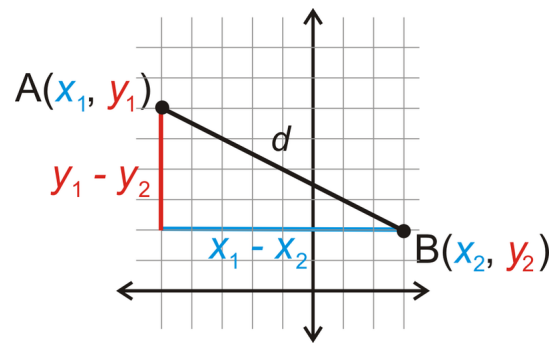

Now that we have a right triangle, we can use the Pythagorean Theorem to find the hypotenuse, d .

$$d^2 = (x_1 - x_2)^2 + (y_1 - y_2)^2$$

$$d = \sqrt{(x_1 - x_2)^2 + (y_1 - y_2)^2}$$

Distance Formula: The distance between $A(x_1, y_1)$ and $B(x_2, y_2)$ is $d = \sqrt{(x_1 - x_2)^2 + (y_1 - y_2)^2}$.

Classify a Triangle as Acute, Right, or Obtuse

We can extend the converse of the Pythagorean Theorem to determine if a triangle is an obtuse or acute triangle.

Acute Triangles: If the sum of the squares of the two shorter sides in a right triangle is *greater* than the square of the longest side, then the triangle is *acute*.

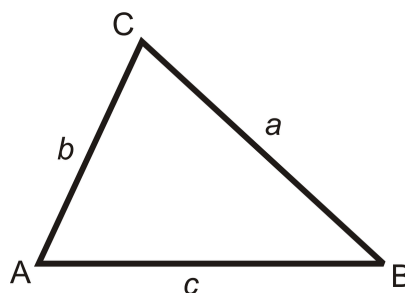

For $b < c$ and $a < c$, if $a^2 + b^2 > c^2$, then the triangle is acute.

Obtuse Triangles: If the sum of the squares of the two shorter sides in a right triangle is *less* than the square of the longest side, then the triangle is *obtuse*.

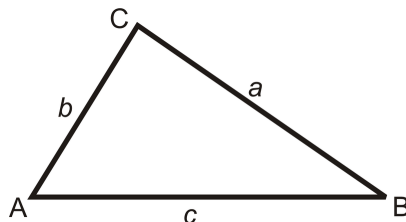

For $b < c$ and $a < c$, if $a^2 + b^2 < c^2$, then the triangle is obtuse.

Example A

What is the height of the isosceles triangle?

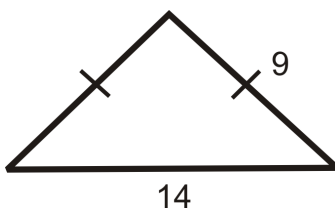

Draw the altitude from the vertex between the congruent sides, which will bisect the base.

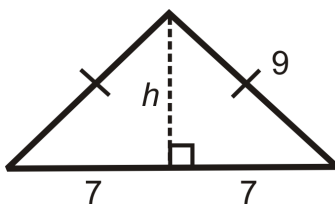

$$7^2 + h^2 = 9^2$$

$$49 + h^2 = 81$$

$$h^2 = 32$$

$$h = \sqrt{32} = \sqrt{16 \cdot 2} = 4\sqrt{2}$$

Example B

Find the distance between (1, 5) and (5, 2).

Make $A(1, 5)$ and $B(5, 2)$. Plug into the distance formula.

$$\begin{aligned} d &= \sqrt{(1-5)^2 + (5-2)^2} \\ &= \sqrt{(-4)^2 + (3)^2} \\ &= \sqrt{16+9} = \sqrt{25} = 5 \end{aligned}$$

Just like the lengths of the sides of a triangle, distances are always positive.

Example C

Graph $A(-4, 1)$, $B(3, 8)$, and $C(9, 6)$. Determine if $\triangle ABC$ is acute, obtuse, or right.

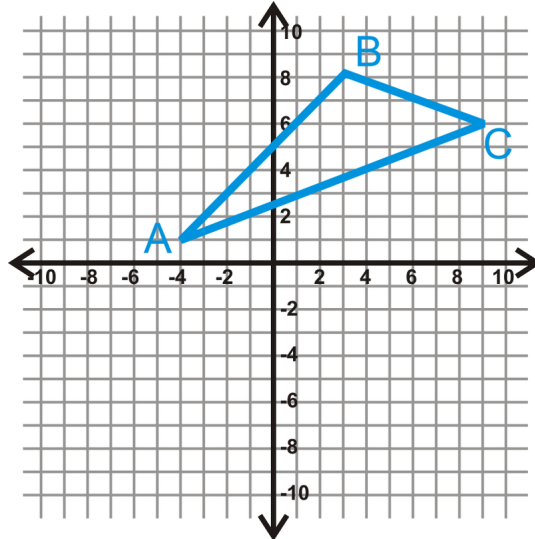

Use the distance formula to find the length of each side.

$$AB = \sqrt{(-4 - 3)^2 + (1 - 8)^2} = \sqrt{49 + 49} = \sqrt{98}$$

$$BC = \sqrt{(3 - 9)^2 + (8 - 6)^2} = \sqrt{36 + 4} = \sqrt{40}$$

$$AC = \sqrt{(-4 - 9)^2 + (1 - 6)^2} = \sqrt{169 + 25} = \sqrt{194}$$

Plug these lengths into the Pythagorean Theorem.

$$\begin{aligned} (\sqrt{98})^2 + (\sqrt{40})^2 &? (\sqrt{194})^2 \\ 98 + 40 &? 194 \\ 138 &< 194 \end{aligned}$$

$\triangle ABC$ is an obtuse triangle.



MEDIA

Click image to the left for more content.

Guided Practice

Determine if the following triangles are acute, right or obtuse.

1.

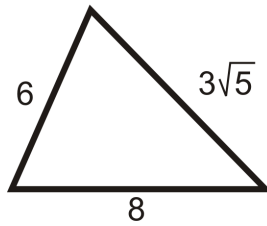

2.

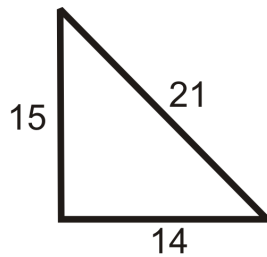

3. A triangle with side lengths 5, 12, 13.

Answers:

Set the longest side equal to c .

1.

$$\begin{aligned} 6^2 + (3\sqrt{5})^2 &? 8^2 \\ 36 + 45 &? 64 \\ 81 &> 64 \end{aligned}$$

The triangle is acute.

2.

$$\begin{aligned} 15^2 + 14^2 &? 21^2 \\ 225 + 196 &? 441 \\ 421 &< 441 \end{aligned}$$

The triangle is obtuse.

3. $5^2 + 12^2 = 13^2$ so this triangle is right.

Practice

Find the height of each isosceles triangle below. Simplify all radicals.

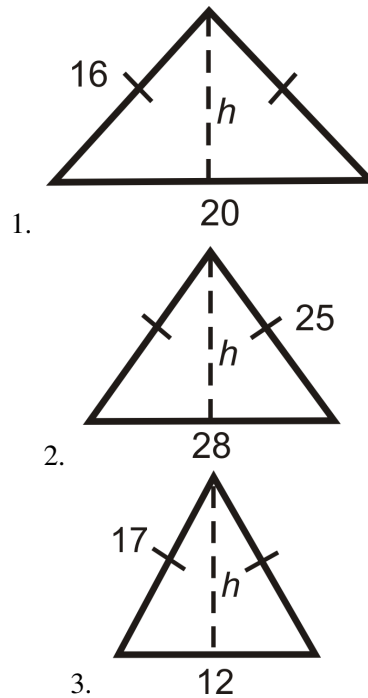

Find the length between each pair of points.

4. $(-1, 6)$ and $(7, 2)$
5. $(10, -3)$ and $(-12, -6)$
6. $(1, 3)$ and $(-8, 16)$
7. What are the length and width of a 42" HDTV? Round your answer to the nearest tenth.
8. Standard definition TVs have a length and width ratio of 4:3. What are the length and width of a 42" Standard definition TV? Round your answer to the nearest tenth.

Determine whether the following triangles are acute, right or obtuse.

9. 7, 8, 9
10. 14, 48, 50
11. 5, 12, 15
12. 13, 84, 85
13. 20, 20, 24
14. 35, 40, 51
15. 39, 80, 89
16. 20, 21, 38
17. 48, 55, 76

Graph each set of points and determine whether $\triangle ABC$ is acute, right, or obtuse, using the distance formula.

18. $A(3, -5), B(-5, -8), C(-2, 7)$
19. $A(5, 3), B(2, -7), C(-1, 5)$
20. $A(1, 6), B(5, 2), C(-2, 3)$
21. $A(-6, 1), B(-4, -5), C(5, -2)$

8.4 Inscribed Similar Triangles

Here you'll learn the Inscribed Similar Triangles Theorem that states that a line drawn from the right angle of a right triangle perpendicular to the opposite side of the triangle creates similar triangles. You'll then use this fact to find missing lengths in right triangles.

What if you drew a line from the right angle of a right triangle perpendicular to the side that is opposite that angle? How could you determine the length of that line? After completing this Concept, you'll be able to solve problems like this one.

Watch This



MEDIA

Click image to the left for more content.

CK-12 Foundation: [Inscribed Similar Triangles](#)

Guidance

Remember that if two objects are similar, their corresponding angles are congruent and their sides are proportional in length. The altitude of a right triangle creates similar triangles.

Inscribed Similar Triangles Theorem: If an altitude is drawn from the right angle of any right triangle, then the two triangles formed are similar to the original triangle and all three triangles are similar to each other.

In $\triangle ADB$, $m\angle A = 90^\circ$ and $\overline{AC} \perp \overline{DB}$:

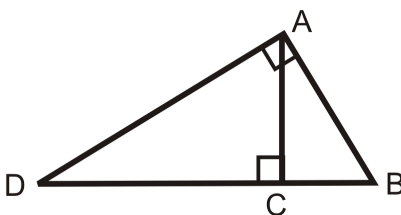

So, $\triangle ADB \sim \triangle CDA \sim \triangle CAB$:

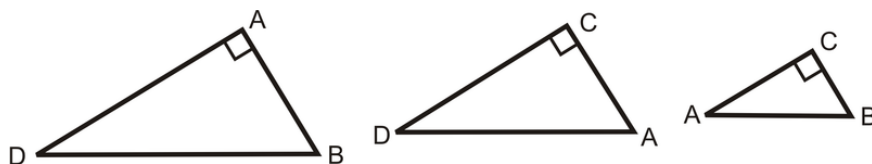

This means that all of the corresponding sides are proportional. You can use this fact to find missing lengths in right triangles.

Example A

Find the value of x .

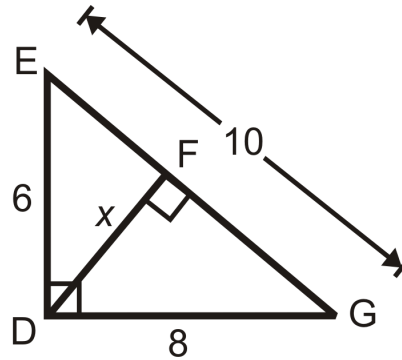

Separate the triangles to find the corresponding sides.

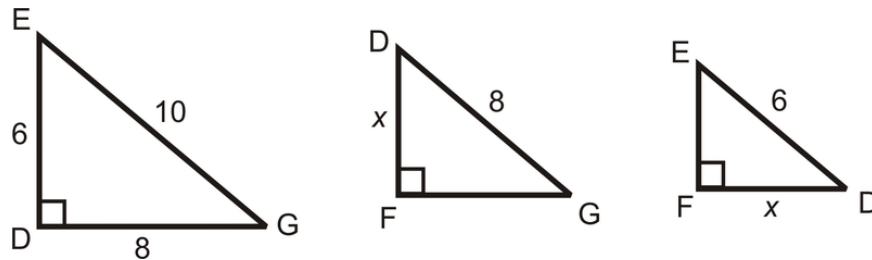

Set up a proportion.

$$\frac{\text{shorter leg in } \triangle EDG}{\text{shorter leg in } \triangle DFG} = \frac{\text{hypotenuse in } \triangle EDG}{\text{hypotenuse in } \triangle DFG}$$

$$\frac{6}{x} = \frac{10}{8}$$

$$48 = 10x$$

$$4.8 = x$$

Example B

Find the value of x .

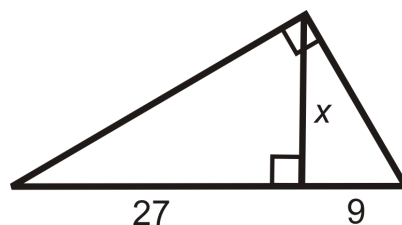

Set up a proportion.

$$\frac{\text{shorter leg of smallest } \triangle}{\text{shorter leg of middle } \triangle} = \frac{\text{longer leg of smallest } \triangle}{\text{longer leg of middle } \triangle}$$

$$\frac{9}{x} = \frac{x}{27}$$

$$x^2 = 243$$

$$x = \sqrt{243} = 9\sqrt{3}$$

Example C

Find the values of x and y .

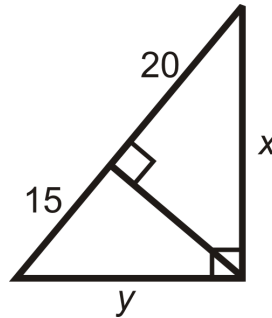

Separate the triangles. Write a proportion for x .

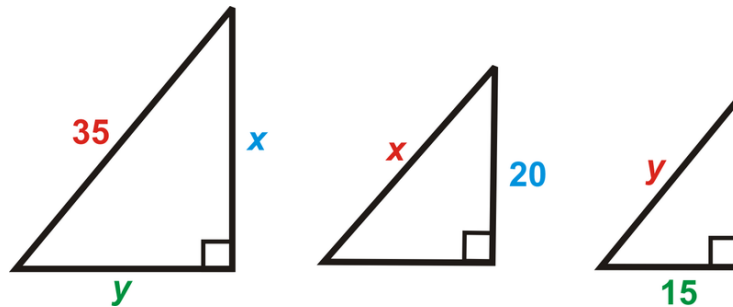

$$\frac{20}{x} = \frac{x}{35}$$

$$x^2 = 20 \cdot 35$$

$$x = \sqrt{20 \cdot 35}$$

$$x = 10\sqrt{7}$$

Set up a proportion for y . Or, now that you know the value of x you can use the Pythagorean Theorem to solve for y . Use the method you feel most comfortable with.

$$\frac{15}{y} = \frac{y}{35}$$

$$y^2 = 15 \cdot 35$$

$$y = \sqrt{15 \cdot 35}$$

$$y = 5\sqrt{21}$$

$$(10\sqrt{7})^2 + y^2 = 35^2$$

$$700 + y^2 = 1225$$

$$y = \sqrt{525} = 5\sqrt{21}$$



MEDIA

Click image to the left for more content.

CK-12 Foundation: Inscribed Similar Triangles

Guided Practice

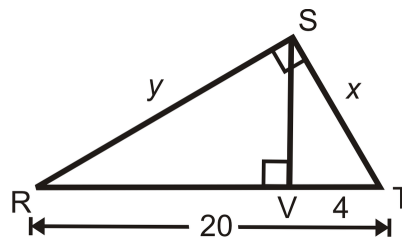
- Find the value of x .

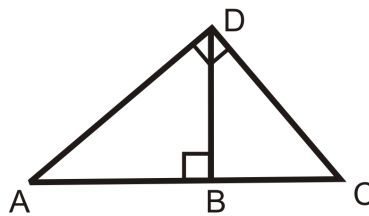

- Now find the value of y in $\triangle RST$ above.
- Write the similarity statement for the right triangles in the diagram.

Answers:

- Set up a proportion.

$$\frac{\text{shorter leg in } \triangle SVT}{\text{shorter leg in } \triangle RST} = \frac{\text{hypotenuse in } \triangle SVT}{\text{hypotenuse in } \triangle RST}$$

$$\frac{4}{x} = \frac{x}{20}$$

$$x^2 = 80$$

$$x = \sqrt{80} = 4\sqrt{5}$$

- Use the Pythagorean Theorem.

$$\begin{aligned}
 y^2 + (4\sqrt{5})^2 &= 20^2 \\
 y^2 + 80 &= 400 \\
 y^2 &= 320 \\
 y &= \sqrt{320} = 8\sqrt{5}
 \end{aligned}$$

3. $\triangle ACD \sim \triangle DCB \sim \triangle ADB$

Practice

Fill in the blanks.

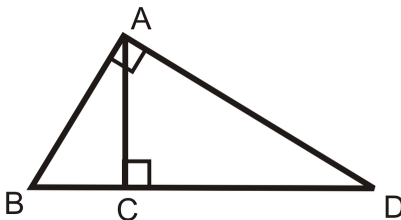

1. $\triangle BAD \sim \triangle \underline{\hspace{1cm}} \sim \triangle \underline{\hspace{1cm}}$
2. $\frac{BC}{?} = \frac{?}{CD}$
3. $\frac{BC}{AB} = \frac{AB}{?}$
4. $\frac{?}{AD} = \frac{AD}{BD}$

Write the similarity statement for the right triangles in each diagram.

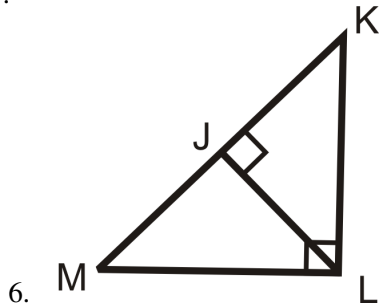
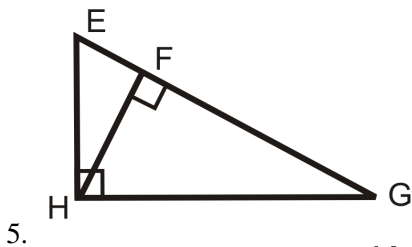

Use the diagram to answer questions 7-10.

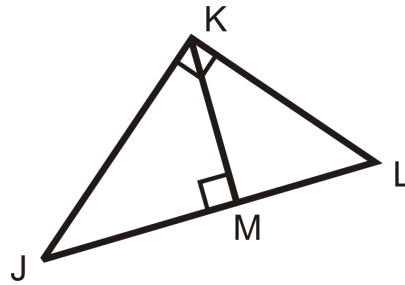

7. Write the similarity statement for the three triangles in the diagram.
8. If $JM = 12$ and $ML = 9$, find KM .
9. Find JK .
10. Find KL .

Find the length of the missing variable(s). Simplify all radicals.

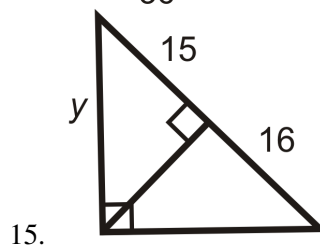
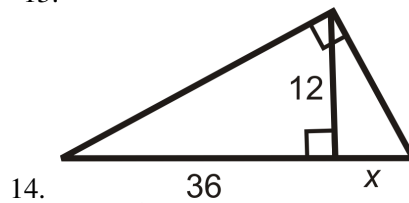
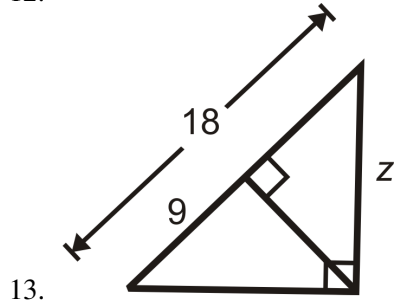
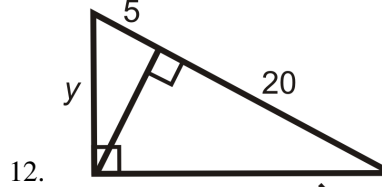
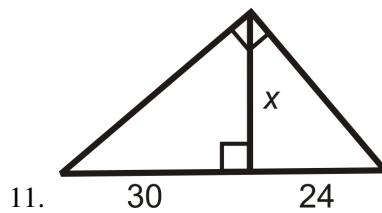

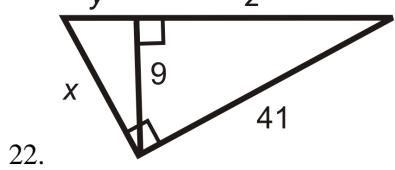
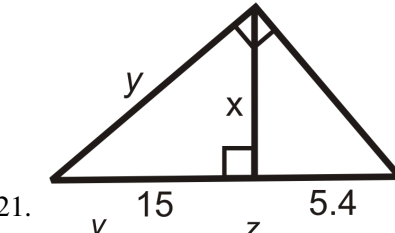
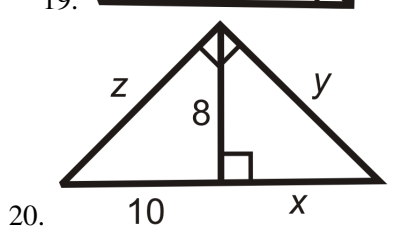
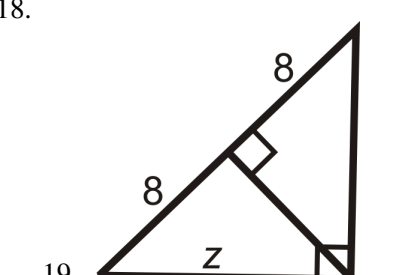
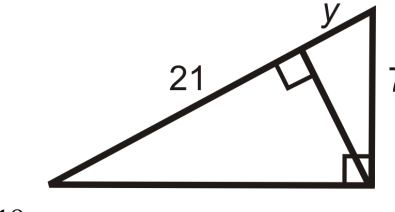
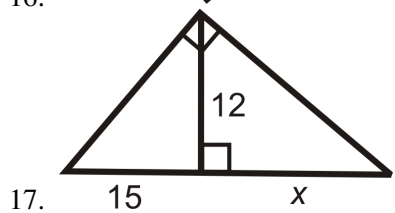
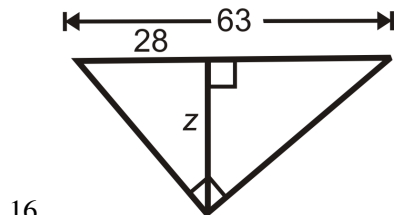

23. Fill in the blanks of the proof for the Inscribed Similar Triangles Theorem.

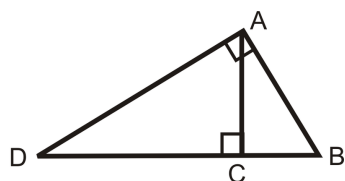

Given: $\triangle ABD$ with $\overline{AC} \perp \overline{DB}$ and $\angle DAB$ is a right angle.

Prove: $\triangle ABD \sim \triangle CBA \sim \triangle CAD$

TABLE 8.1:

<i>Statement</i>	<i>Reason</i>
1.	1. Given
2. $\angle DCA$ and $\angle ACB$ are right angles	2.
3. $\angle DAB \cong \angle DCA \cong \angle ACB$	3.
4.	4. Reflexive PoC
5.	5. AA Similarity Postulate
6. $B \cong \angle B$	6.
7. $\triangle CBA \cong \triangle ABD$	7.
8. $\triangle CAD \cong \triangle CBA$	8.

8.5 45-45-90 Right Triangles

Here you'll learn that the sides of a 45-45-90 right triangle are in the ratio $x : x : x\sqrt{2}$.

What if you were given an isosceles right triangle and the length of one of its sides? How could you figure out the lengths of its other sides? After completing this Concept, you'll be able to use the 45-45-90 Theorem to solve problems like this one.

Watch This



MEDIA

Click image to the left for more content.

CK-12 Foundation: Special Right Triangle: 45-45-90

Watch the second half of this video.

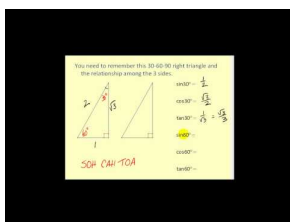

MEDIA

Click image to the left for more content.

James Sousa:Trigonometric Function Values of Special Angles

Now watch the second half of this video.

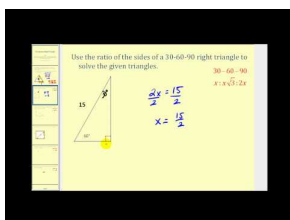

MEDIA

Click image to the left for more content.

James Sousa:SolvingSpecialRight Triangles

Guidance

A right triangle with congruent legs and acute angles is an **Isosceles Right Triangle**. This triangle is also called a 45-45-90 triangle (named after the angle measures).

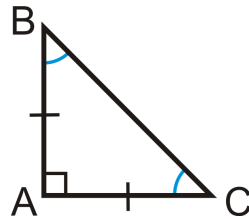

$\triangle ABC$ is a right triangle with $m\angle A = 90^\circ$, $\overline{AB} \cong \overline{AC}$ and $m\angle B = m\angle C = 45^\circ$.

45-45-90 Theorem: If a right triangle is isosceles, then its sides are in the ratio $x : x : x\sqrt{2}$. For any isosceles right triangle, the legs are x and *the hypotenuse is always* $x\sqrt{2}$.

Example A

Find the length of the missing side.

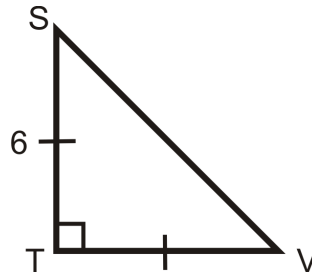

Use the $x : x : x\sqrt{2}$ ratio. $TV = 6$ because it is equal to ST . So, $SV = 6 \cdot \sqrt{2} = 6\sqrt{2}$.

Example B

Find the length of the missing side.

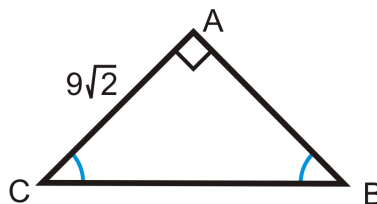

Use the $x : x : x\sqrt{2}$ ratio. $AB = 9\sqrt{2}$ because it is equal to AC . So, $BC = 9\sqrt{2} \cdot \sqrt{2} = 9 \cdot 2 = 18$.

Example C

A square has a diagonal with length 10, what are the lengths of the sides?

Draw a picture.

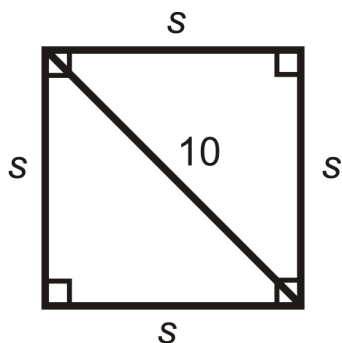

We know half of a square is a 45-45-90 triangle, so $10 = s\sqrt{2}$.

$$s\sqrt{2} = 10$$

$$s = \frac{10}{\sqrt{2}} \cdot \frac{\sqrt{2}}{\sqrt{2}} = \frac{10\sqrt{2}}{2} = 5\sqrt{2}$$



MEDIA

Click image to the left for more content.

CK-12 Foundation: Special Right Triangle: 45-45-90

Guided Practice

Find the length of x .

1.

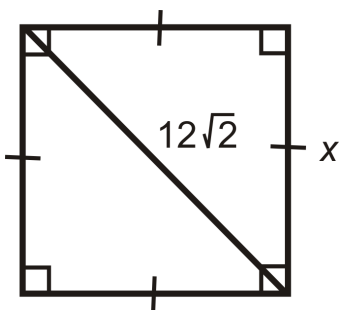

2.

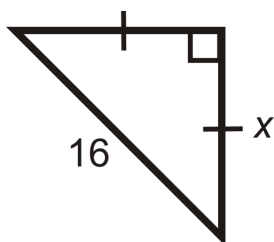

3. x is the hypotenuse of a 45-45-90 triangle with leg lengths of $5\sqrt{3}$.

Answers:

Use the $x : x : x\sqrt{2}$ ratio.

1. $12\sqrt{2}$ is the diagonal of the square. Remember that the diagonal of a square bisects each angle, so it splits the square into two 45-45-90 triangles. $12\sqrt{2}$ would be the hypotenuse, or equal to $x\sqrt{2}$.

$$\begin{aligned} 12\sqrt{2} &= x\sqrt{2} \\ 12 &= x \end{aligned}$$

2. Here, we are given the hypotenuse. Solve for x in the ratio.

$$\begin{aligned} x\sqrt{2} &= 16 \\ x &= \frac{16}{\sqrt{2}} \cdot \frac{\sqrt{2}}{\sqrt{2}} = \frac{16\sqrt{2}}{2} = 8\sqrt{2} \end{aligned}$$

$$3. x = 5\sqrt{3} \cdot \sqrt{2} = 5\sqrt{6}$$

Practice

1. In an isosceles right triangle, if a leg is 4, then the hypotenuse is _____.
2. In an isosceles right triangle, if a leg is x , then the hypotenuse is _____.
3. A square has sides of length 15. What is the length of the diagonal?
4. A square's diagonal is 22. What is the length of each side?

For questions 5-11, find the lengths of the missing sides. Simplify all radicals.

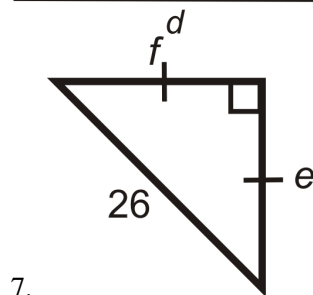
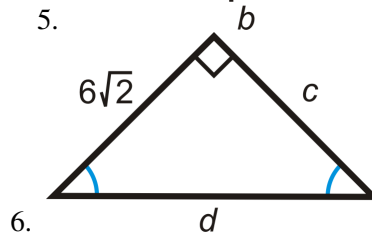
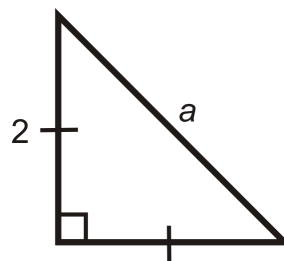

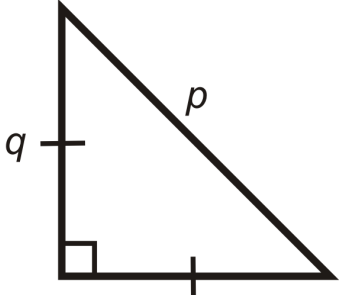
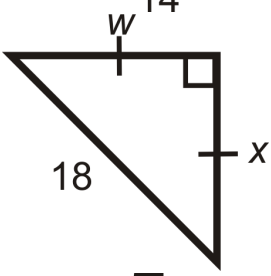
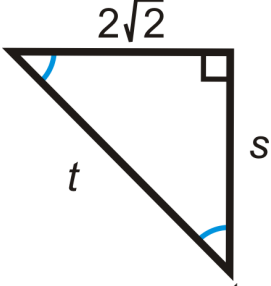
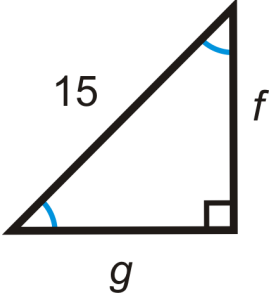
8. 
9. 
10. 
11. 

8.6 30-60-90 Right Triangles

Here you'll learn that the sides of a 30-60-90 right triangle are in the ratio $x : x\sqrt{3} : 2x$.

What if you were given a 30-60-90 right triangle and the length of one of its side? How could you figure out the lengths of its other sides? After completing this Concept, you'll be able to use the 30-60-90 Theorem to solve problems like this one.

Watch This



MEDIA

Click image to the left for more content.

CK-12 Foundation: Special Right Triangle: 30-60-90

Watch the first half of this video.

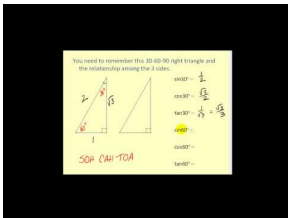

MEDIA

Click image to the left for more content.

James Sousa: Trigonometric Function Values of Special Angles

Now watch the first half of this video.

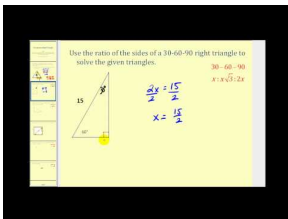

MEDIA

Click image to the left for more content.

James Sousa: Solving Special Right Triangles

Guidance

One of the two special right triangles is called a 30-60-90 triangle, after its three angles.

30-60-90 Theorem: If a triangle has angle measures 30° , 60° and 90° , then the sides are in the ratio $x : x\sqrt{3} : 2x$.

The shorter leg is always x , the longer leg is always $x\sqrt{3}$, and the hypotenuse is always $2x$. If you ever forget these theorems, you can still use the Pythagorean Theorem.

Example A

Find the length of the missing side.

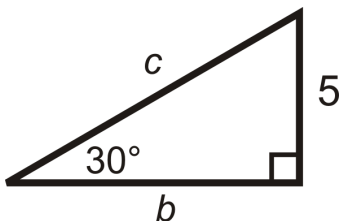

We are given the shorter leg. If $x = 5$, then the longer leg, $b = 5\sqrt{3}$, and the hypotenuse, $c = 2(5) = 10$.

Example B

Find the length of the missing side.

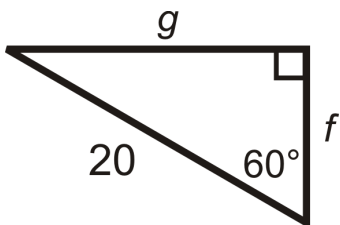

We are given the hypotenuse. $2x = 20$, so the shorter leg, $f = \frac{20}{2} = 10$, and the longer leg, $g = 10\sqrt{3}$.

Example C

A rectangle has sides 4 and $4\sqrt{3}$. What is the length of the diagonal?

If you are not given a picture, draw one.

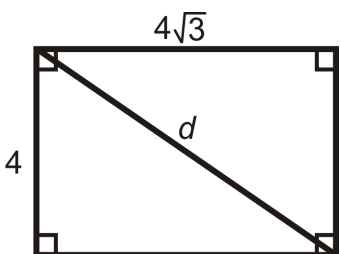

The two lengths are $x, x\sqrt{3}$, so the diagonal would be $2x$, or $2(4) = 8$.

If you did not recognize this is a 30-60-90 triangle, you can use the Pythagorean Theorem too.

$$\begin{aligned} 4^2 + (4\sqrt{3})^2 &= d^2 \\ 16 + 48 &= d^2 \\ d &= \sqrt{64} = 8 \end{aligned}$$



MEDIA

 Click image to the left for more content.

CK-12 Foundation: Special Right Triangle: 30-60-90

Guided Practice

 Find the value of x and y .

1.

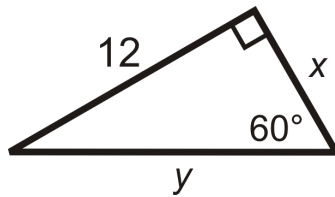

2.

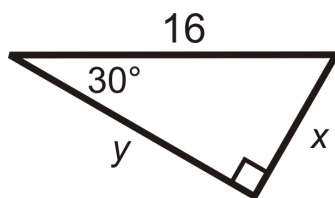

3. x is the hypotenuse of a 30-60-90 triangle and y is the longer leg of the same triangle. The shorter leg has a length of 6.

Answers:

1. We are given the longer leg.

$$x\sqrt{3} = 12$$

$$x = \frac{12}{\sqrt{3}} \cdot \frac{\sqrt{3}}{\sqrt{3}} = \frac{12\sqrt{3}}{3} = 4\sqrt{3}$$

The hypotenuse is

$$y = 2(4\sqrt{3}) = 8\sqrt{3}$$

2. We are given the hypotenuse.

$$2x = 16$$

$$x = 8$$

The longer leg is

$$y = 8 \cdot \sqrt{3} = 8\sqrt{3}$$

3. We are given the shorter leg.

$$x = 2(6)$$

$$x = 12$$

The longer leg is

$$y = 6 \cdot \sqrt{3} = 6\sqrt{3}$$

Practice

- In a 30-60-90 triangle, if the shorter leg is 5, then the longer leg is _____ and the hypotenuse is _____.
- In a 30-60-90 triangle, if the shorter leg is x , then the longer leg is _____ and the hypotenuse is _____.
- A rectangle has sides of length 6 and $6\sqrt{3}$. What is the length of the diagonal?
- Two (opposite) sides of a rectangle are 10 and the diagonal is 20. What is the length of the other two sides?

For questions 5-12, find the lengths of the missing sides. Simplify all radicals.

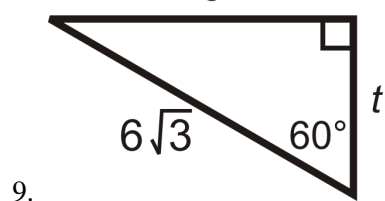
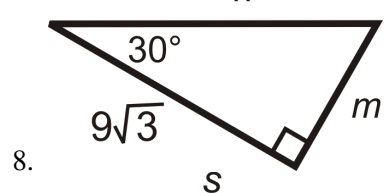
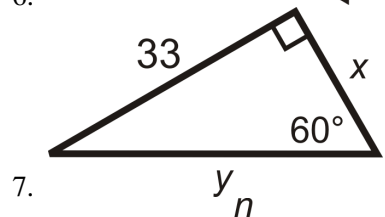
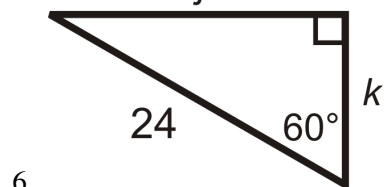
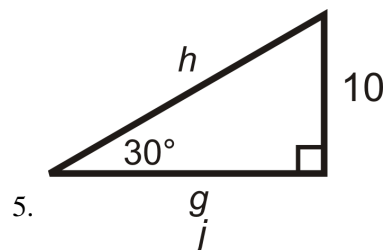

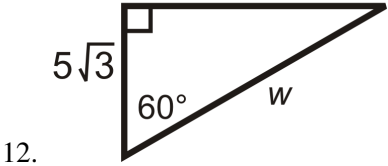
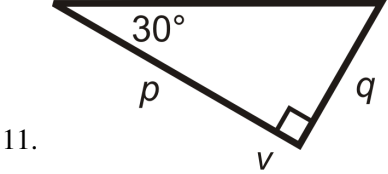
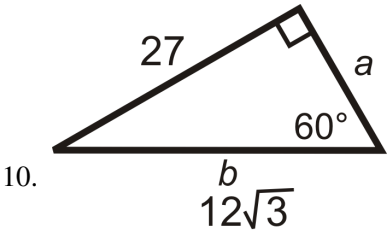

8.7 Sine, Cosine, Tangent

Here you'll learn what the three trigonometric ratios are and how to find their value for a right triangle's non-right angle.

What if you were given a right triangle and told that its sides measure 3, 4, and 5 inches? How could you find the sine, cosine, and tangent of one of the triangle's non-right angles? After completing this Concept, you'll be able to solve for these trigonometric ratios.

Watch This



MEDIA

Click image to the left for more content.

CK-12 Foundation: The Trigonometric Ratios

Watch the parts of the video dealing with the sine, cosine, and tangent.

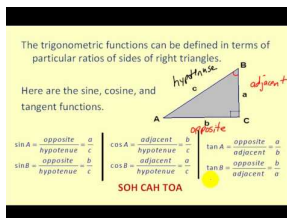

MEDIA

Click image to the left for more content.

James Sousa: Introduction to Trigonometric Functions Using Triangles

Guidance

Trigonometry is the study of the relationships between the sides and angles of right triangles. The legs are called *adjacent* or *opposite* depending on which *acute* angle is being used.

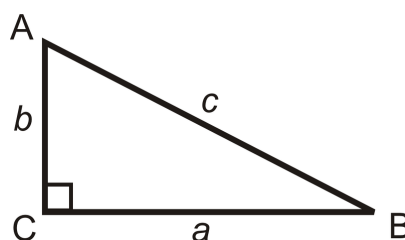

a is adjacent to $\angle B$ a is opposite $\angle A$
 b is adjacent to $\angle A$ b is opposite $\angle B$
 c is the hypotenuse

The three basic trigonometric ratios are called sine, cosine and tangent. For right triangle $\triangle ABC$, we have:

Sine Ratio: $\frac{\text{opposite leg}}{\text{hypotenuse}}$ $\sin A = \frac{a}{c}$ or $\sin B = \frac{b}{c}$

Cosine Ratio: $\frac{\text{adjacent leg}}{\text{hypotenuse}}$ $\cos A = \frac{b}{c}$ or $\cos B = \frac{a}{c}$

Tangent Ratio: $\frac{\text{opposite leg}}{\text{adjacent leg}}$ $\tan A = \frac{a}{b}$ or $\tan B = \frac{b}{a}$

An easy way to remember ratios is to use SOH-CAH-TOA.

$$\text{Sine} = \frac{\text{Opposite}}{\text{Hypotenuse}} \quad \text{Cosine} = \frac{\text{Adjacent}}{\text{Hypotenuse}} \quad \text{Tangent} = \frac{\text{Opposite}}{\text{Adjacent}}$$

A few important points:

- Always **reduce ratios** (fractions) when you can.
- Use the Pythagorean Theorem to find the missing side (if there is one).
- If there is a radical in the denominator, **rationalize the denominator**.

Example A

Find the sine, cosine and tangent ratios of $\angle A$.

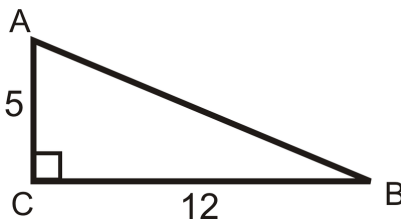

First, we need to use the Pythagorean Theorem to find the length of the hypotenuse.

$$5^2 + 12^2 = c^2$$

$$13 = c$$

$$\sin A = \frac{\text{leg opposite } \angle A}{\text{hypotenuse}} = \frac{5}{13}$$

$$\cos A = \frac{\text{leg adjacent to } \angle A}{\text{hypotenuse}} = \frac{12}{13},$$

$$\tan A = \frac{\text{leg opposite } \angle A}{\text{leg adjacent to } \angle A} = \frac{5}{12}$$

Example B

Find the sine, cosine, and tangent of $\angle B$.

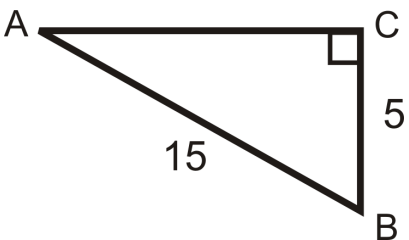

Find the length of the missing side.

$$AC^2 + 5^2 = 15^2$$

$$AC^2 = 200$$

$$AC = 10\sqrt{2}$$

$$\sin B = \frac{10\sqrt{2}}{15} = \frac{2\sqrt{2}}{3}$$

$$\cos B = \frac{5}{15} = \frac{1}{3}$$

$$\tan B = \frac{10\sqrt{2}}{5} = 2\sqrt{2}$$

Example C

Find the sine, cosine and tangent of 30° .

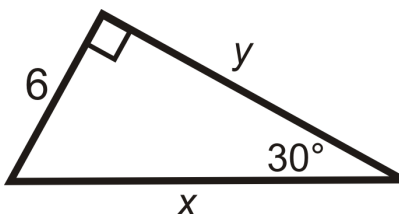

This is a 30-60-90 triangle. The short leg is 6, $y = 6\sqrt{3}$ and $x = 12$.

$$\sin 30^\circ = \frac{6}{12} = \frac{1}{2}$$

$$\cos 30^\circ = \frac{6\sqrt{3}}{12} = \frac{\sqrt{3}}{2}$$

$$\tan 30^\circ = \frac{6}{6\sqrt{3}} = \frac{1}{\sqrt{3}} \cdot \frac{\sqrt{3}}{\sqrt{3}} = \frac{\sqrt{3}}{3}$$



MEDIA

Click image to the left for more content.

[CK-12 Foundation: The Trigonometric Ratios](#)

Guided Practice

Answer the questions about the following image. Reduce all fractions.

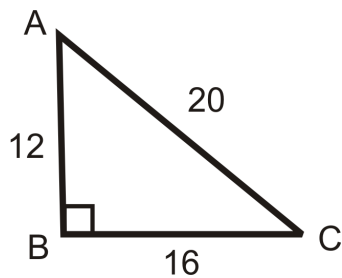

1. What is $\sin A$?
2. What is $\cos A$?
3. What is $\tan A$?

Answers:

1. $\sin A = \frac{16}{20} = \frac{4}{5}$
2. $\cos A = \frac{12}{20} = \frac{3}{5}$
3. $\tan A = \frac{16}{12} = \frac{4}{3}$

Practice

Use the diagram to fill in the blanks below.

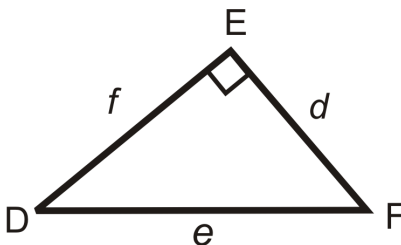

1. $\tan D = \frac{?}{?}$
2. $\sin F = \frac{?}{?}$
3. $\tan F = \frac{?}{?}$
4. $\cos F = \frac{?}{?}$
5. $\sin D = \frac{?}{?}$
6. $\cos D = \frac{?}{?}$

From questions 1-6, we can conclude the following. Fill in the blanks.

7. $\cos \underline{\quad} = \sin F$ and $\sin \underline{\quad} = \cos F$.
8. $\tan D$ and $\tan F$ are of each other.

Find the sine, cosine and tangent of $\angle A$. Reduce all fractions and radicals.

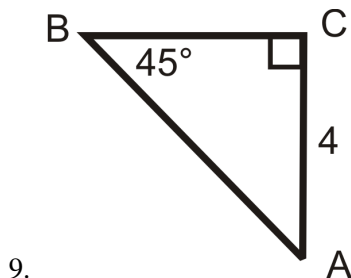

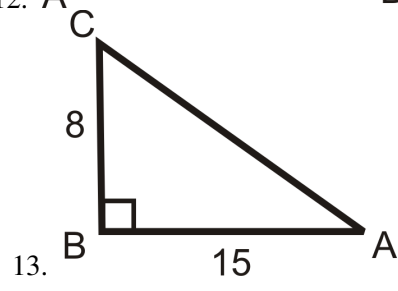
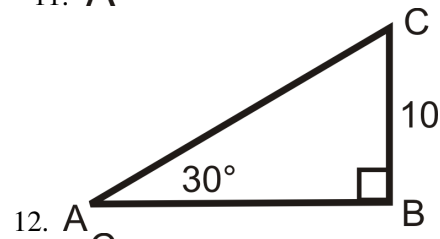
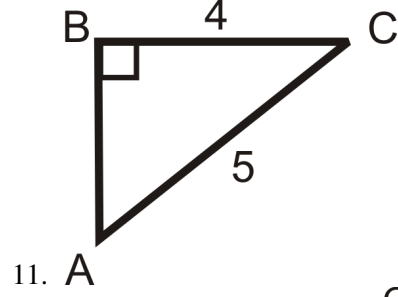
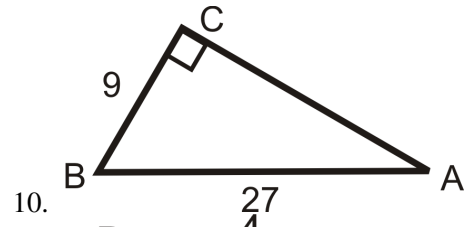

8.8 Trigonometric Ratios with a Calculator

Here you'll learn how to solve for missing sides in right triangles that are not one of the special right triangles.

What if you were given a 20-70-90 triangle? How could you find the sine, cosine, and tangent of the 20° and 70° angles? After completing this Concept, you'll be able to use a calculator to find the trigonometric ratios for angles that do not measure 45°, 30°, or 60°.

Watch This



MEDIA

Click image to the left for more content.

CK-12 Foundation: The Trigonometric Ratios with a Calculator

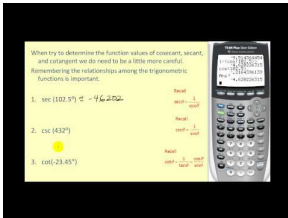

MEDIA

Click image to the left for more content.

James Sousa: Determining Trigonometric Function Values on the Calculator

Guidance

There is a fixed sine, cosine, and tangent value for every angle, from 0° to 90°. Your scientific (or graphing) calculator knows all the trigonometric values for any angle. Your calculator, should have [SIN], [COS], and [TAN] buttons. You can use your calculator and the trigonometric ratios to find the missing sides of a right triangle by setting up a trig equation.

Example A

Find the trigonometric value, using your calculator. Round to 4 decimal places.

- $\sin 78^\circ$
- $\cos 60^\circ$
- $\tan 15^\circ$

Depending on your calculator, you enter the degree and then press the trig button or the other way around. Also, make sure the mode of your calculator is in *DEGREES*.

a) $\sin 78^\circ = 0.97815$

b) $\cos 60^\circ = 0.5$

c) $\tan 15^\circ = 0.26795$

Example B

Find the value of each variable. Round your answer to the nearest tenth.

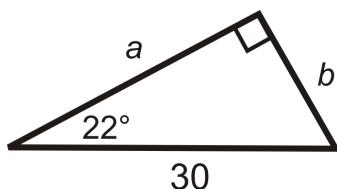

We are given the hypotenuse. Use *sine* to find b , and *cosine* to find a . Use your calculator to evaluate the sine and cosine of the angles.

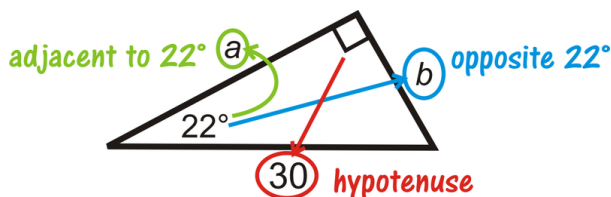

$$\begin{aligned}\sin 22^\circ &= \frac{b}{30} \\ 30 \cdot \sin 22^\circ &= b \\ b &\approx 11.2\end{aligned}$$

$$\begin{aligned}\cos 22^\circ &= \frac{a}{30} \\ 30 \cdot \cos 22^\circ &= a \\ a &\approx 27.8\end{aligned}$$

Example C

Find the value of each variable. Round your answer to the nearest tenth.

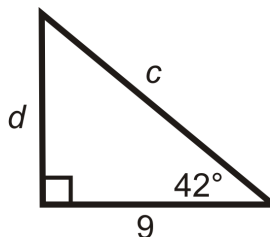

We are given the adjacent leg to 42° . To find c , use *cosine* and use *tangent* to find d .

$$\begin{aligned}\cos 42^\circ &= \frac{\text{adjacent}}{\text{hypotenuse}} = \frac{9}{c} \\ c \cdot \cos 42^\circ &= 9 \\ c &= \frac{9}{\cos 42^\circ} \approx 12.1\end{aligned}$$

$$\begin{aligned}\tan 42^\circ &= \frac{\text{opposite}}{\text{adjacent}} = \frac{d}{9} \\ 9 \cdot \tan 42^\circ &= d \\ d &\approx 27.0\end{aligned}$$

Any time you use trigonometric ratios, use only the information that you are given. This will result in the most accurate answers.



MEDIA

Click image to the left for more content.

CK-12 Foundation: The Trigonometric Ratios with a Calculator

Guided Practice

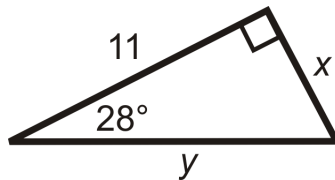
1. What is $\tan 45^\circ$?
2. Find the length of the missing sides and round your answers to the nearest tenth:

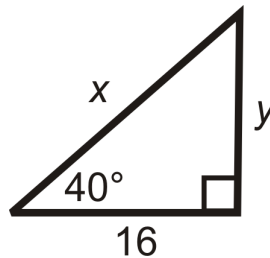

3. Find the length of the missing sides and round your answers to the nearest tenth:

Answers:

1. Using your calculator, you should find that $\tan 45^\circ = 1$?
2. Use tangent for x and cosine for y .

$$\begin{aligned}\tan 28^\circ &= \frac{x}{11} \\ 11 \cdot \tan 28^\circ &= x \\ x &\approx 5.8\end{aligned}$$

$$\begin{aligned}\cos 28^\circ &= \frac{11}{y} \\ \frac{11}{\cos 28^\circ} &= y \\ y &\approx 12.5\end{aligned}$$

3. Use tangent for y and cosine for x .

$$\begin{aligned}\tan 40^\circ &= \frac{y}{16} \\ 16 \cdot \tan 40^\circ &= y \\ y &\approx 13.4\end{aligned}$$

$$\begin{aligned}\cos 40^\circ &= \frac{16}{x} \\ \frac{16}{\cos 40^\circ} &= x \\ x &\approx 20.9\end{aligned}$$

Practice

Use your calculator to find the value of each trig function below. Round to four decimal places.

1. $\sin 24^\circ$
2. $\cos 45^\circ$
3. $\tan 88^\circ$
4. $\sin 43^\circ$
5. $\tan 12^\circ$
6. $\cos 79^\circ$
7. $\sin 82^\circ$

Find the length of the missing sides. Round your answers to the nearest tenth.

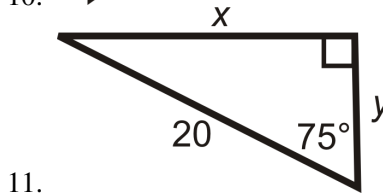
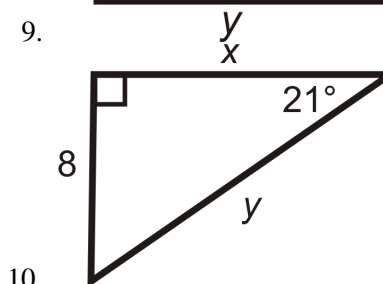
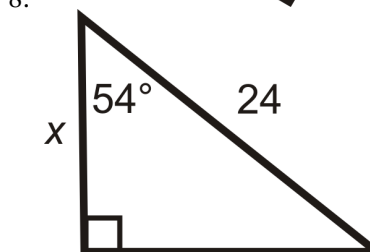
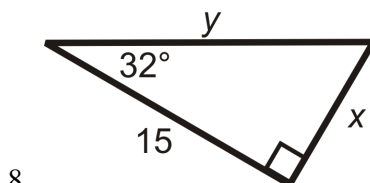

8.9 Trigonometry Word Problems

Here you'll learn how to solve word problems using the trigonometric ratios.

What if you placed a ladder 10 feet from a haymow whose floor is 20 feet from the ground? How tall would the ladder need to be to reach the haymow's floor if it forms a 30° angle with the ground? After completing this Concept, you'll be able to solve angle of elevation and angle of depression word problems like this one.

Watch This



MEDIA

Click image to the left for more content.

CK-12 Foundation: Trigonometry Word Problems

First watch this video.

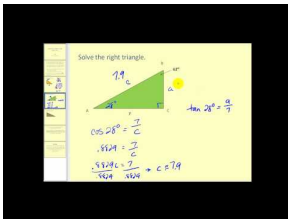

MEDIA

Click image to the left for more content.

James Sousa:SolvingRight Triangles- The Basics

Then watch this video.

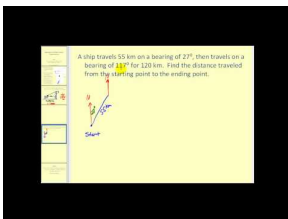

MEDIA

Click image to the left for more content.

James Sousa:SolvingRight Triangles- Applications

Guidance

One application of the trigonometric ratios is to find lengths that you cannot measure. Very frequently, angles of depression and elevation are used in these types of problems.

Angle of Depression: The angle measured down from the horizon or a horizontal line.



Angle of Elevation: The angle measured up from the horizon or a horizontal line.

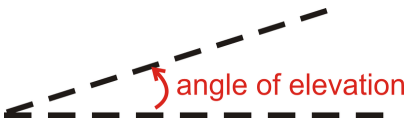

Example A

A math student is standing 25 feet from the base of the Washington Monument. The angle of elevation from her horizontal line of sight is 87.4° . If her “eye height” is 5 ft, how tall is the monument?



We can find the height of the monument by using the tangent ratio.

$$\tan 87.4^\circ = \frac{h}{25}$$

$$h = 25 \cdot \tan 87.4^\circ = 550.54$$

Adding 5 ft, the total height of the Washington Monument is 555.54 ft.

Example B

A 25 foot tall flagpole casts a 42 foot shadow. What is the angle that the sun hits the flagpole?

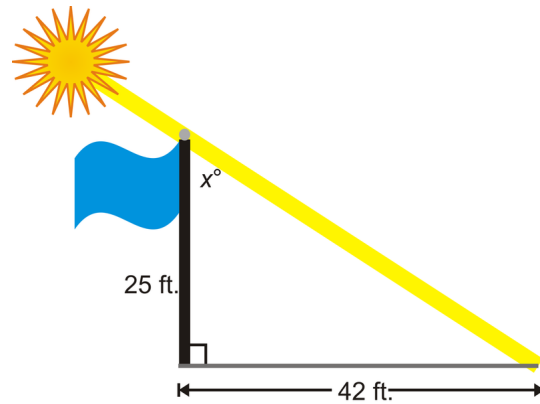

Draw a picture. The angle that the sun hits the flagpole is x° . We need to use the inverse tangent ratio.

$$\tan x = \frac{42}{25}$$

$$\tan^{-1} \frac{42}{25} \approx 59.2^\circ = x$$

Example C

Elise is standing on top of a 50 foot building and sees her friend, Molly. If Molly is 30 feet away from the base of the building, what is the angle of depression from Elise to Molly? Elise's eye height is 4.5 feet.

Because of parallel lines, the angle of depression is equal to the angle at Molly, or x° . We can use the inverse tangent ratio.

$$\tan^{-1} \left(\frac{54.5}{30} \right) = 61.2^\circ = x$$

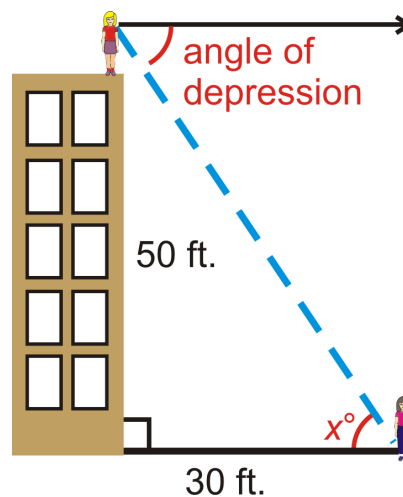

Multimedia

MEDIA

Click image to the left for more content.

CK-12 Foundation: Trigonometry Word Problems

Guided Practice

1. Mark is flying a kite and realizes that 300 feet of string are out. The angle of the string with the ground is 42.5° . How high is Mark's kite above the ground?
2. A 20 foot ladder rests against a wall. The base of the ladder is 7 feet from the wall. What angle does the ladder make with the ground?
3. A 20 foot ladder rests against a wall. The ladder makes a 55° angle with the ground. How far from the wall is the base of the ladder?

Answers

1. It might help to draw a picture. Then write and solve a trig equation.

$$\begin{aligned}\sin 42.5^\circ &= \frac{x}{300} \\ 300 \cdot \sin 42.5^\circ &= x \\ x &\approx 202.7\end{aligned}$$

The kite is about 202.7 feet off of the ground.

2. It might help to draw a picture.

$$\begin{aligned}\cos x &= \frac{7}{20} \\ x &= \cos^{-1} \frac{7}{20} \\ x &\approx 69.5^\circ\end{aligned}$$

3. It might help to draw a picture.

$$\begin{aligned}\cos 55^\circ &= \frac{x}{20} \\ 20 \cdot \cos 55^\circ &= x \\ x &\approx 11.5\text{ ft}\end{aligned}$$

Practice

1. Kristin is swimming in the ocean and notices a coral reef below her. The angle of depression is 35° and the depth of the ocean, at that point is 250 feet. How far away is she from the reef?

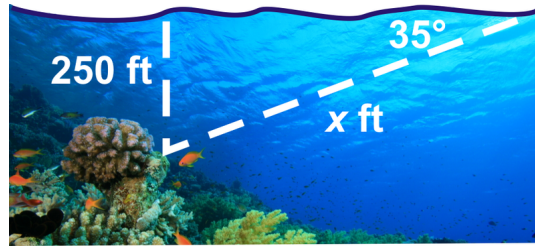

2. The Leaning Tower of Pisa currently “leans” at a 4° angle and has a vertical height of 55.86 meters. How tall was the tower when it was originally built?

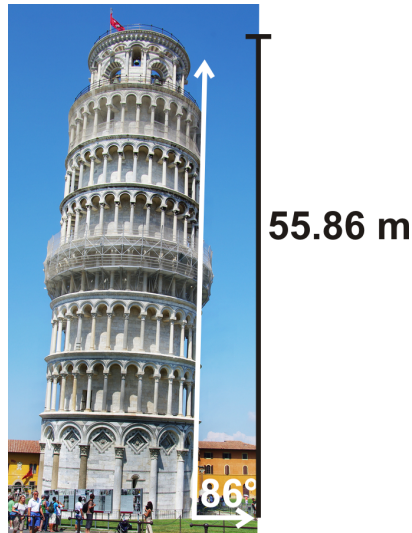

Use what you know about right triangles to solve for the missing angle. If needed, draw a picture. Round all answers to the nearest tenth of a degree.

3. A 75 foot building casts an 82 foot shadow. What is the angle that the sun hits the building?
4. Over 2 miles (horizontal), a road rises 300 feet (vertical). What is the angle of elevation?
5. A boat is sailing and spots a shipwreck 650 feet below the water. A diver jumps from the boat and swims 935 feet to reach the wreck. What is the angle of depression from the boat to the shipwreck?
6. Standing 100 feet from the base of a building, Sam measures the angle to the top of the building from his eye height to be 50° . If his eyes are 6 feet above the ground, how tall is the building?
7. Over 4 miles (horizontal), a road rises 200 feet (vertical). What is the angle of elevation?
8. A 90 foot building casts an 110 foot shadow. What is the angle that the sun hits the building?
9. Luke is flying a kite and realizes that 400 feet of string are out. The angle of the string with the ground is 50° . How high is Luke’s kite above the ground?
10. An 18 foot ladder rests against a wall. The base of the ladder is 10 feet from the wall. What angle does the ladder make with the ground?

8.10 Inverse Trigonometric Ratios

Here you'll learn how to apply the three inverse trigonometric ratios, the inverse sine, the inverse cosine, and the inverse tangent, to find angle measures.

What if you were told the tangent of $\angle Z$ is 0.6494? How could you find the measure of $\angle Z$? After completing this Concept, you'll be able to find angle measures by using the inverse trigonometric ratios.

Watch This



MEDIA

Click image to the left for more content.

CK-12 Foundation: The Inverse Trigonometric Ratios

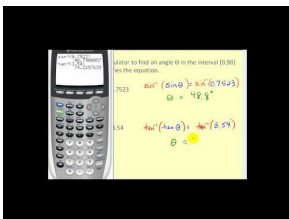

MEDIA

Click image to the left for more content.

James Sousa: Introduction to Inverse Trigonometric Functions

Guidance

In mathematics, the word inverse means “undo.” For example, addition and subtraction are inverses of each other because one undoes the other. When we use the inverse trigonometric ratios, we can find acute angle measures as long as we are given two sides.

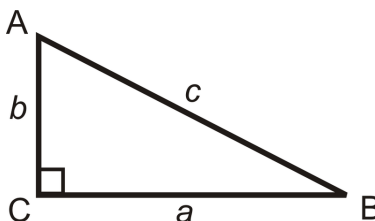

Inverse Tangent: Labeled \tan^{-1} , the “-1” means inverse.

$$\tan^{-1}\left(\frac{b}{a}\right) = m\angle B \text{ and } \tan^{-1}\left(\frac{a}{b}\right) = m\angle A.$$

Inverse Sine: Labeled \sin^{-1} .

$$\sin^{-1}\left(\frac{b}{c}\right) = m\angle B \text{ and } \sin^{-1}\left(\frac{a}{c}\right) = m\angle A.$$

Inverse Cosine: Labeled \cos^{-1} .

$$\cos^{-1}\left(\frac{a}{c}\right) = m\angle B \text{ and } \cos^{-1}\left(\frac{b}{c}\right) = m\angle A.$$

In most problems, to find the measure of the angles you will need to use your calculator. On most scientific and graphing calculators, the buttons look like $[\text{SIN}^{-1}]$, $[\text{COS}^{-1}]$, and $[\text{TAN}^{-1}]$. You might also have to hit a shift or 2^{nd} button to access these functions.

Now that you know both the trig ratios and the inverse trig ratios you can **solve** a right triangle. To solve a right triangle, you need to find all sides and angles in it. You will usually use sine, cosine, or tangent; inverse sine, inverse cosine, or inverse tangent; or the Pythagorean Theorem.

Example A

Use the sides of the triangle and your calculator to find the value of $\angle A$. Round your answer to the nearest tenth of a degree.

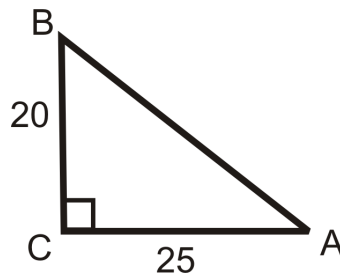

In reference to $\angle A$, we are given the *opposite* leg and the *adjacent* leg. This means we should use the *tangent* ratio.

$$\tan A = \frac{20}{25} = \frac{4}{5}. \text{ So, } \tan^{-1}\frac{4}{5} = m\angle A. \text{ Now, use your calculator.}$$

If you are using a TI-83 or 84, the keystrokes would be: $[2^{\text{nd}}][\text{TAN}]\left(\frac{4}{5}\right)[\text{ENTER}]$ and the screen looks like:

$$\tan^{-1}(4/5) \\ 38.65980825$$

$$m\angle A \approx 38.7^\circ$$

Example B

$\angle A$ is an acute angle in a right triangle. Find $m\angle A$ to the nearest tenth of a degree.

a) $\sin A = 0.68$

b) $\cos A = 0.85$

c) $\tan A = 0.34$

Answers:

a) $m\angle A = \sin^{-1} 0.68 \approx 42.8^\circ$

b) $m\angle A = \cos^{-1} 0.85 \approx 31.8^\circ$

c) $m\angle A = \tan^{-1} 0.34 \approx 18.8^\circ$

Example C

Solve the right triangle.

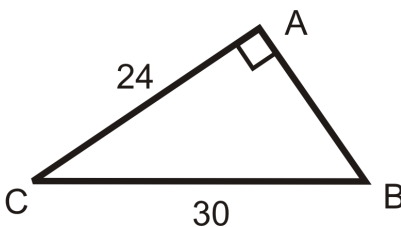

To solve this right triangle, we need to find AB , $m\angle C$ and $m\angle B$. Use only the values you are given.

AB : Use the Pythagorean Theorem.

$$\begin{aligned} 24^2 + AB^2 &= 30^2 \\ 576 + AB^2 &= 900 \\ AB^2 &= 324 \\ AB &= \sqrt{324} = 18 \end{aligned}$$

$m\angle B$: Use the inverse sine ratio.

$$\begin{aligned} \sin B &= \frac{24}{30} = \frac{4}{5} \\ \sin^{-1}\left(\frac{4}{5}\right) &\approx 53.1^\circ = m\angle B \end{aligned}$$

$m\angle C$: Use the inverse cosine ratio.

$$\cos C = \frac{24}{30} = \frac{4}{5} \rightarrow \cos^{-1}\left(\frac{4}{5}\right) \approx 36.9^\circ = m\angle C$$

**MEDIA**

Click image to the left for more content.

[CK-12 Foundation: The Inverse Trigonometric Ratios](#)

Guided Practice

1. Solve the right triangle.

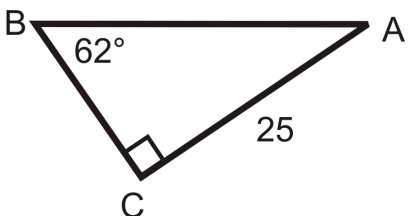

2. Solve the right triangle.

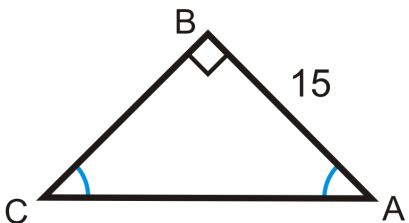

3. When would you use \sin and when would you use \sin^{-1} ?

Answers:

1. To solve this right triangle, we need to find AB , BC and $m\angle A$.

AB : Use the sine ratio.

$$\begin{aligned}\sin 62^\circ &= \frac{25}{AB} \\ AB &= \frac{25}{\sin 62^\circ} \\ AB &\approx 28.31\end{aligned}$$

BC : Use the tangent ratio.

$$\begin{aligned}\tan 62^\circ &= \frac{25}{BC} \\ BC &= \frac{25}{\tan 62^\circ} \\ BC &\approx 13.30\end{aligned}$$

$m\angle A$: Use the Triangle Sum Theorem

$$\begin{aligned}62^\circ + 90^\circ + m\angle A &= 180^\circ \\ m\angle A &= 28^\circ\end{aligned}$$

2. The two acute angles are congruent, making them both 45° . This is a 45-45-90 triangle. You can use the trigonometric ratios or the special right triangle ratios.

Trigonometric Ratios

$$\begin{aligned}\tan 45^\circ &= \frac{15}{BC} \\ BC &= \frac{15}{\tan 45^\circ} = 15\end{aligned}$$

$$\begin{aligned}\sin 45^\circ &= \frac{15}{AC} \\ AC &= \frac{15}{\sin 45^\circ} \approx 21.21\end{aligned}$$

45-45-90 Triangle Ratios

$$BC = AB = 15, AC = 15\sqrt{2} \approx 21.21$$

3. You would use \sin when you are given an angle and you are solving for a missing side. You would use \sin^{-1} when you are given sides and you are solving for a missing angle.

Practice

Use your calculator to find $m\angle A$ to the nearest tenth of a degree.

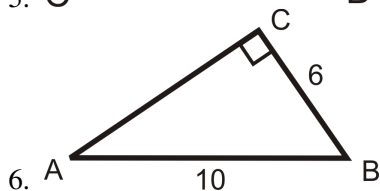
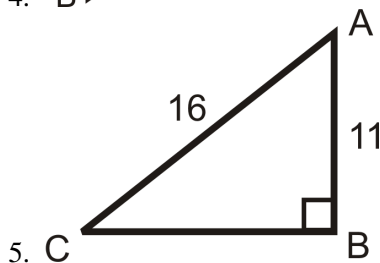
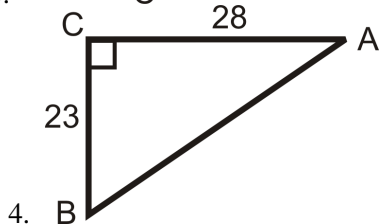
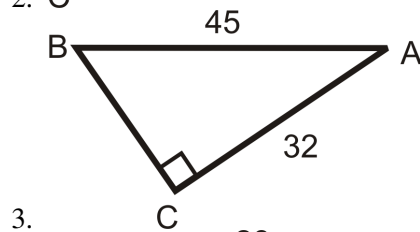
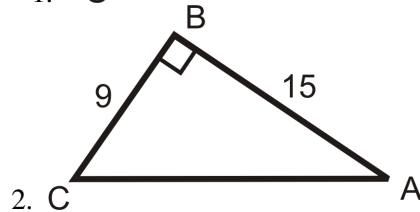
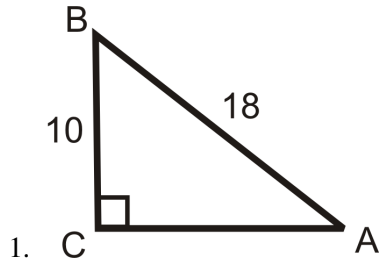

Let $\angle A$ be an acute angle in a right triangle. Find $m\angle A$ to the nearest tenth of a degree.

7. $\sin A = 0.5684$
8. $\cos A = 0.1234$
9. $\tan A = 2.78$
10. $\cos^{-1} 0.9845$
11. $\tan^{-1} 15.93$
12. $\sin^{-1} 0.7851$

Solving the following right triangles. Find all missing sides and angles. Round any decimal answers to the nearest tenth.

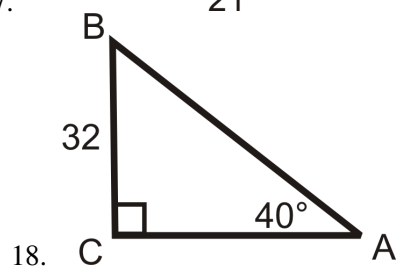
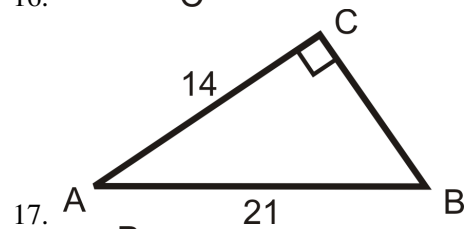
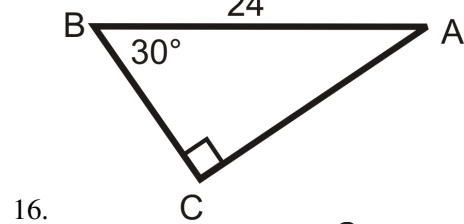
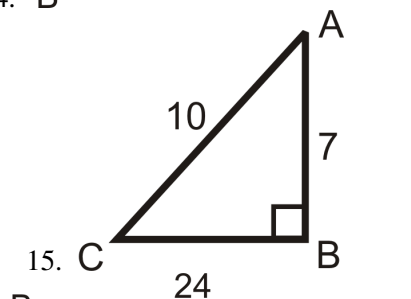
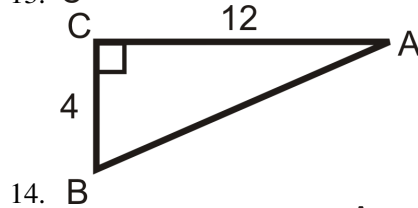
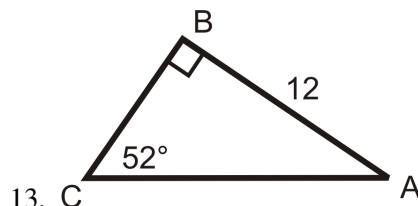

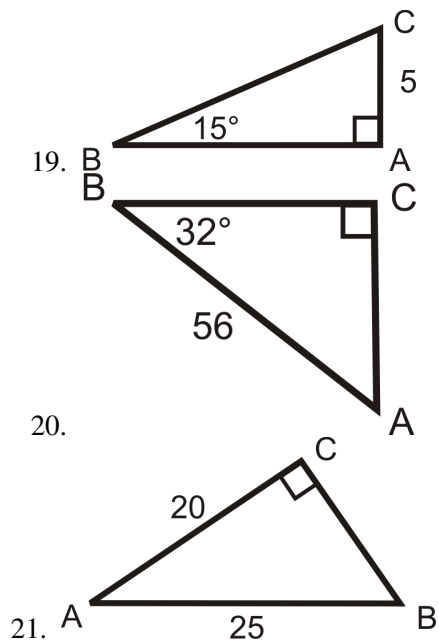

Summary

This chapter begins with a review of how to simplify radicals, an important prerequisite technique for working with the Pythagorean Theorem. The Pythagorean Theorem, its converse, and Pythagorean triples are discussed in detail. Applications of the Pythagorean Theorem are explored including finding missing lengths in right triangles. The chapter then branches out into applications of special right triangles, namely 45-45-90 and 30-60-90. The connection between trigonometry and geometry is explored through trigonometric ratios, trigonometry word problems and inverse trigonometric ratios at the end of this chapter.

CHAPTER 9**Circles****Chapter Outline**

- 9.1 PARTS OF CIRCLES**
 - 9.2 TANGENT LINES**
 - 9.3 ARCS IN CIRCLES**
 - 9.4 CHORDS IN CIRCLES**
 - 9.5 INSCRIBED ANGLES IN CIRCLES**
 - 9.6 INSCRIBED QUADRILATERALS IN CIRCLES**
 - 9.7 ANGLES ON AND INSIDE A CIRCLE**
 - 9.8 ANGLES OUTSIDE A CIRCLE**
 - 9.9 SEGMENTS FROM CHORDS**
 - 9.10 SEGMENTS FROM SECANTS**
 - 9.11 SEGMENTS FROM SECANTS AND TANGENTS**
 - 9.12 CIRCLES IN THE COORDINATE PLANE**
-

Introduction

First, we will define all the parts of circles and explore the properties of tangent lines, arcs, inscribed angles, and chords. Next, we will learn about angles and segments that are formed by chords, tangents and secants. Lastly, we will place circles in the coordinate plane and find the equation of and graph circles.

9.1 Parts of Circles

Here you'll learn all the vocabulary associated with the parts of a circle.

What if you drew a line through a circle from one side to the other that does not pass through the center? What if you drew a line outside a circle that touched the circle at one point? What would you call these lines you drew? After completing this Concept, you'll be able to name circle parts such as these.

Watch This



MEDIA

Click image to the left for more content.

[Parts of Circles CK-12](#)

Watch the first half of this video.

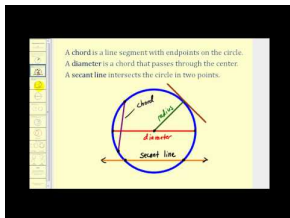

MEDIA

Click image to the left for more content.

[James Sousa: Introduction to Circles](#)

Guidance

A **circle** is the set of all points in the plane that are the same distance away from a specific point, called the **center**. The center of the circle below is point A . We call this circle "circle A ," and it is labeled $\odot A$.

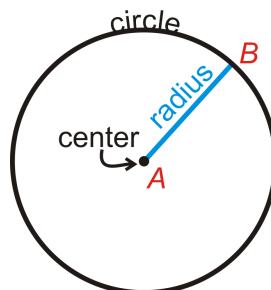

Important Circle Parts

Radius: The distance from the center of the circle to its outer rim.

Chord: A line segment whose endpoints are on a circle.

Diameter: A chord that passes through the center of the circle. The length of a diameter is two times the length of a radius.

Secant: A line that intersects a circle in two points.

Tangent: A line that intersects a circle in exactly one point.

Point of Tangency: The point where a tangent line touches the circle.

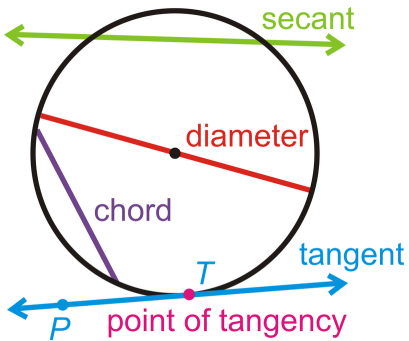

The tangent ray \overrightarrow{TP} and tangent segment \overline{TP} are also called tangents.

Tangent Circles: Two or more circles that intersect at one point.

Concentric Circles: Two or more circles that have the same center, but different radii.

Congruent Circles: Two or more circles with the same radius, but different centers.

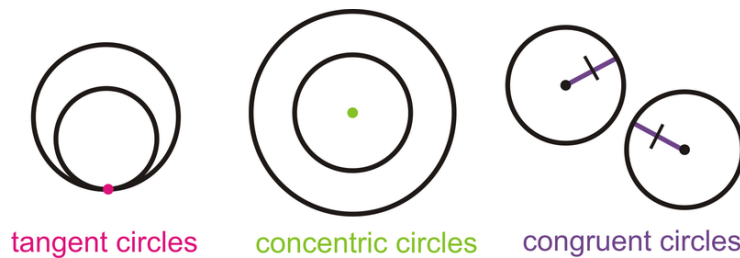

Example A

Find the parts of $\odot A$ that best fit each description.

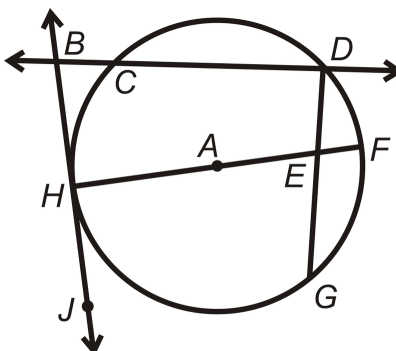

a) A radius

- b) A chord
- c) A tangent line
- d) A point of tangency
- e) A diameter
- f) A secant

Answers:

- a) \overline{HA} or \overline{AF}
- b) \overline{CD} , \overline{HF} , or \overline{DG}
- c) \overleftrightarrow{BJ}
- d) Point H
- e) \overline{HF}
- f) \overleftrightarrow{BD}

Example B

Draw an example of how two circles can intersect with no, one and two points of intersection. You will make three separate drawings.

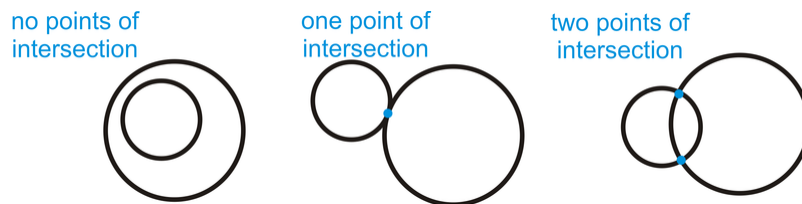

Example C

Determine if any of the following circles are congruent.

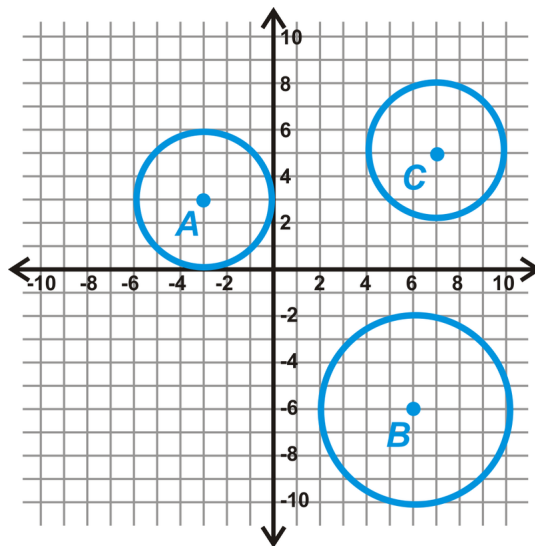

From each center, count the units to the outer rim of the circle. It is easiest to count vertically or horizontally. Doing this, we have:

Radius of $\odot A = 3 \text{ units}$

Radius of $\odot B = 4 \text{ units}$

Radius of $\odot C = 3 \text{ units}$

From these measurements, we see that $\odot A \cong \odot C$.

Notice the ***circles are congruent***. The ***lengths of the radii are equal***.



MEDIA

Click image to the left for more content.

[Parts ofCirclesCK-12](#)

Guided Practice

1. If the diameter of a circle is 10 inches, how long is the radius?
2. Is it possible to have a line that intersects a circle three times? If so, draw one. If not, explain.
3. Are all circles similar?

Answers:

1. The radius is always half the length of the diameter, so it is 5 inches.
2. It is not possible. By definition, all lines are *straight*. The maximum number of times a line can intersect a circle is twice.
3. Yes. All circles are the same shape, but not necessarily the same size, so they are similar.

Practice

Determine which term best describes each of the following parts of $\odot P$.

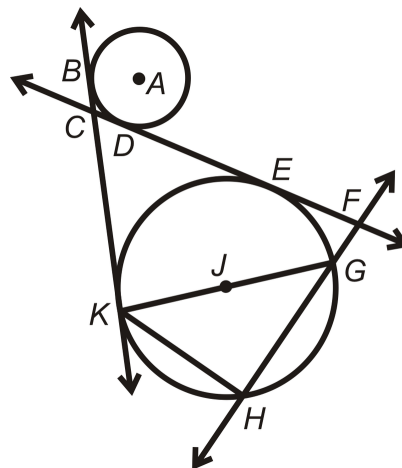

1. \overline{KG}
2. \overline{FH}
3. \overline{KH}
4. \overline{E}
5. \overline{BK}
6. \overline{CF}
7. A
8. \overline{JG}
9. What is the longest chord in any circle?

Use the graph below to answer the following questions.

10. Find the radius of each circle.
11. Are any circles congruent? How do you know?
12. Find all the common tangents for $\odot B$ and $\odot C$.
13. $\odot C$ and $\odot E$ are externally tangent. What is CE ?
14. Find the equation of \overline{CE} .

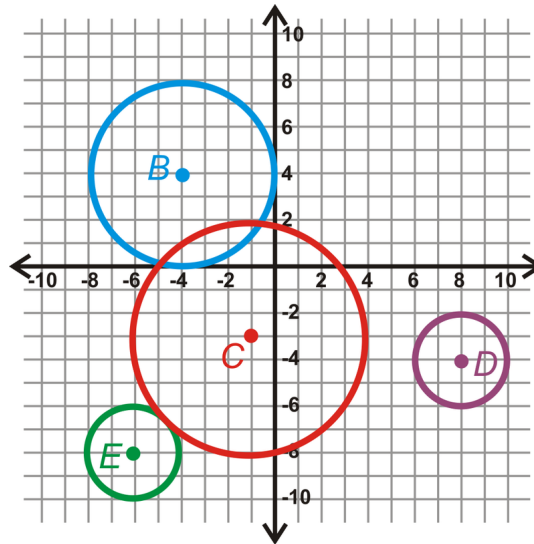

9.2 Tangent Lines

Here you'll learn two theorems about tangent lines: 1) the Tangent to a Circle Theorem that states tangents are perpendicular to radii; and 2) the Two Tangents Theorem that states two tangents drawn from the same point will be congruent.

What if a line were drawn outside a circle that appeared to touch the circle at only one point? How could you determine if that line were actually a tangent? After completing this Concept, you'll be able to apply theorems to solve tangent problems like this one.

Watch This



MEDIA

Click image to the left for more content.

Tangent Lines CK-12

First watch this video.

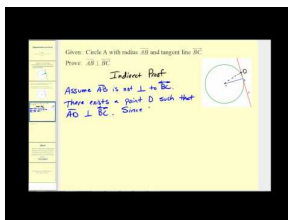

MEDIA

Click image to the left for more content.

James Sousa: Tangent Lines to a Circle

Now watch this video.

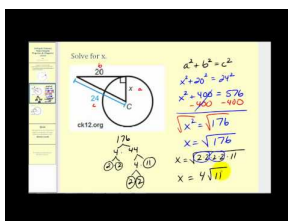

MEDIA

Click image to the left for more content.

James Sousa: Tangent Lines to a Circle Example Problems

Guidance

There are two important theorems about tangent lines.

1) **Tangent to a Circle Theorem:** A line is tangent to a circle if and only if the line is perpendicular to the radius drawn to the point of tangency.

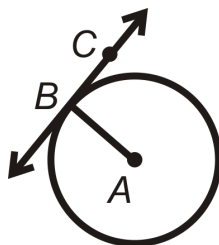

\overleftrightarrow{BC} is tangent at point B if and only if $\overleftrightarrow{BC} \perp \overline{AB}$.

This theorem uses the words “if and only if,” making it a biconditional statement, which means the converse of this theorem is also true.

2) **Two Tangents Theorem:** If two tangent segments are drawn to one circle from the same external point, then they are congruent.

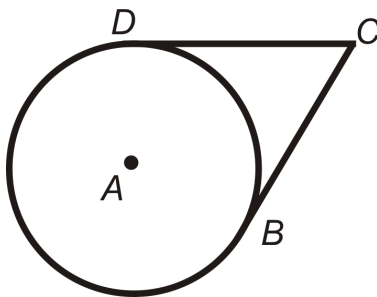

\overline{BC} and \overline{DC} have C as an endpoint and are tangent; $\overline{BC} \cong \overline{DC}$.

Example A

\overline{CB} is tangent to $\odot A$ at point B . Find AC . Reduce any radicals.

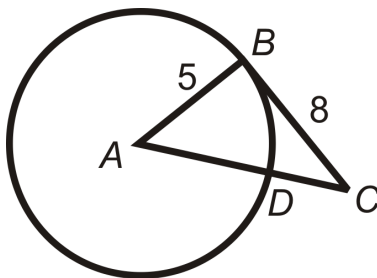

\overline{CB} is tangent, so $\overline{AB} \perp \overline{CB}$ and $\triangle ABC$ a right triangle. Use the Pythagorean Theorem to find AC .

$$5^2 + 8^2 = AC^2$$

$$25 + 64 = AC^2$$

$$89 = AC^2$$

$$AC = \sqrt{89}$$

Example B

Using the answer from Example A above, find DC in $\odot A$. Round your answer to the nearest hundredth.

$$DC = AC - AD$$

$$DC = \sqrt{89} - 5 \approx 4.43$$

Example C

Find the perimeter of $\triangle ABC$.

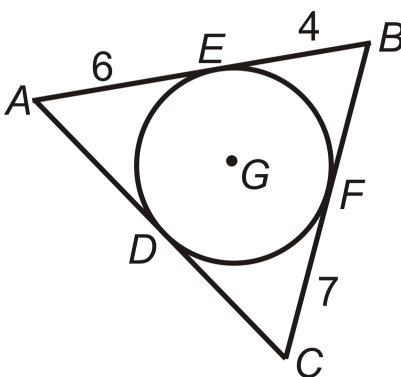

$AE = AD$, $EB = BF$, and $CF = CD$. Therefore, the perimeter of $\triangle ABC = 6 + 6 + 4 + 4 + 7 + 7 = 34$.

$\odot G$ is *inscribed* in $\triangle ABC$. A circle is inscribed in a polygon if every side of the polygon is tangent to the circle.

**MEDIA**

Click image to the left for more content.

Tangent Lines CK-12

Guided Practice

1. Find AB between $\odot A$ and $\odot B$. Reduce the radical.

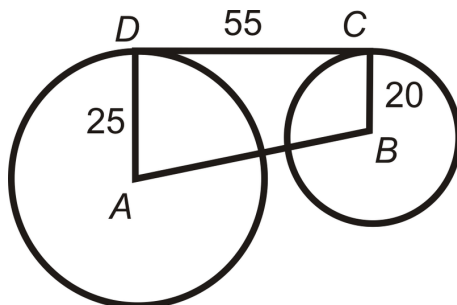

2. Determine if the triangle below is a right triangle.

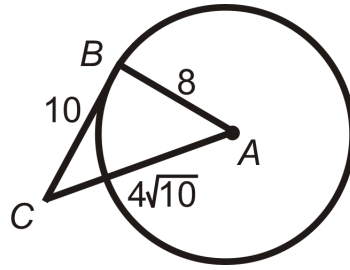

3. If D and C are the centers and AE is tangent to both circles, find DC .

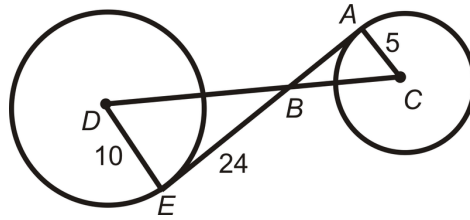

4. Find the value of x .

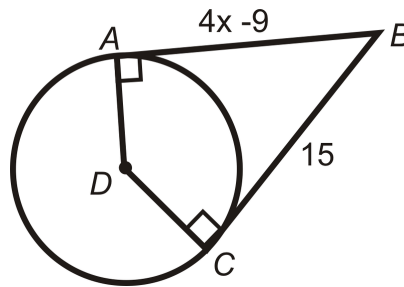

Answers:

1. $\overline{AD} \perp \overline{DC}$ and $\overline{DC} \perp \overline{CB}$. Draw in \overline{BE} , so $EDCB$ is a rectangle. Use the Pythagorean Theorem to find AB .

$$5^2 + 55^2 = AB^2$$

$$25 + 3025 = AB^2$$

$$3050 = AB^2$$

$$AB = \sqrt{3050} = 5\sqrt{122}$$

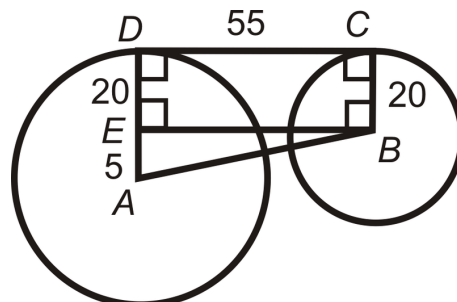

2. Again, use the Pythagorean Theorem. $4\sqrt{10}$ is the longest side, so it will be c .

Does

$$8^2 + 10^2 = (4\sqrt{10})^2?$$

$$64 + 100 \neq 160$$

$\triangle ABC$ is not a right triangle. From this, we also find that \overline{CB} is not tangent to $\odot A$.

3. $\overline{AE} \perp \overline{DE}$ and $\overline{AE} \perp \overline{AC}$ and $\triangle ABC \sim \triangle DBE$ by AA Similarity.

To find DB , use the Pythagorean Theorem.

$$10^2 + 24^2 = DB^2$$

$$100 + 576 = 676$$

$$DB = \sqrt{676} = 26$$

To find BC , use similar triangles. $\frac{5}{10} = \frac{BC}{26} \rightarrow BC = 13$. $DC = DB + BC = 26 + 13 = 39$

4. $\overline{AB} \cong \overline{CB}$ by the Two Tangents Theorem. Set $AB = CB$ and solve for x .

$$4x - 9 = 15$$

$$4x = 24$$

$$x = 6$$

Practice

Determine whether the given segment is tangent to $\odot K$.

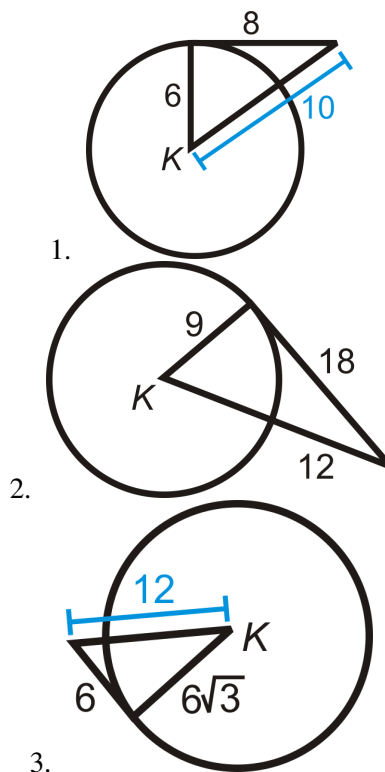

Find the value of the indicated length(s) in $\odot C$. A and B are points of tangency. Simplify all radicals.

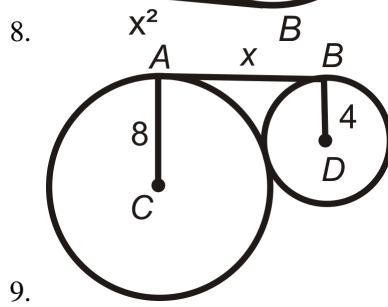
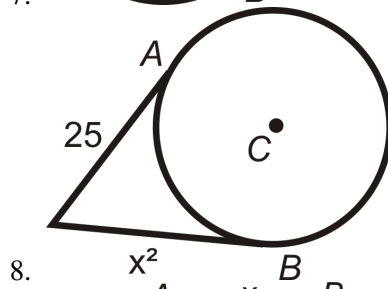
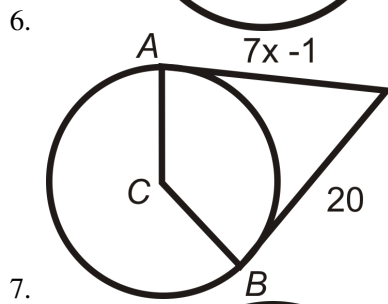
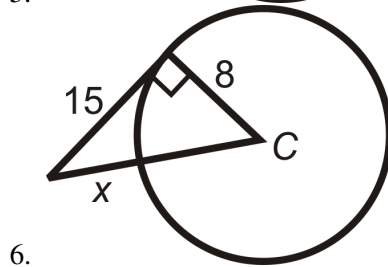
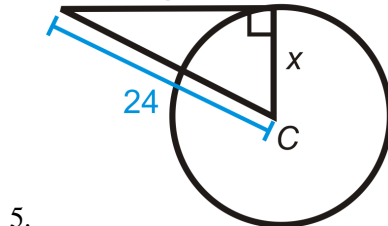
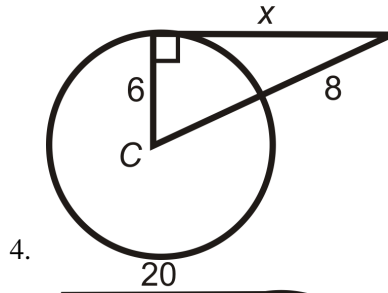

A and B are points of tangency for $\odot C$ and $\odot D$.

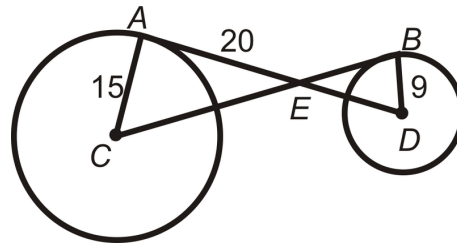

10. Is $\triangle AEC \sim \triangle BED$? Why?
11. Find CE .
12. Find BE .
13. Find ED .
14. Find BC and AD .

⊙A is inscribed in $BDFH$.

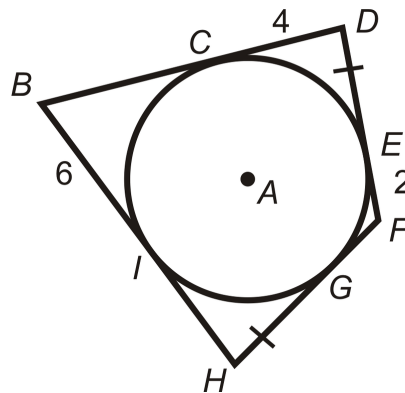

15. Find the perimeter of $BDFH$.
16. What type of quadrilateral is $BDFH$? How do you know?
17. Draw a circle inscribed in a square. If the radius of the circle is 5, what is the perimeter of the square?
18. Can a circle be inscribed in a rectangle? If so, draw it. If not, explain.
19. Draw a triangle with two sides tangent to a circle, but the third side is not.
20. Can a circle be inscribed in an obtuse triangle? If so, draw it. If not, explain.
21. Fill in the blanks in the proof of the Two Tangents Theorem.

Given: \overline{AB} and \overline{CB} with points of tangency at A and C. \overline{AD} and \overline{DC} are radii.

Prove: $\overline{AB} \cong \overline{CB}$

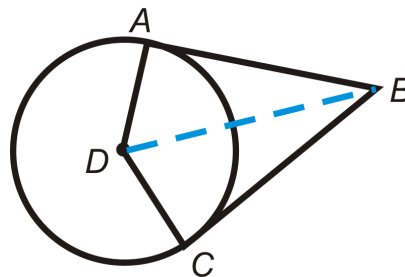

TABLE 9.1:

<i>Statement</i>	<i>Reason</i>
1.	1.
2. $\overline{AD} \cong \overline{DC}$	2.
3. $\overline{DA} \perp \overline{AB}$ and $\overline{DC} \perp \overline{CB}$	3.
4.	4. Definition of perpendicular lines
5.	5. Connecting two existing points
6. $\triangle ADB$ and $\triangle DCB$ are right triangles	6.
7. $\overline{DB} \cong \overline{DB}$	7.
8. $\triangle ABD \cong \triangle CBD$	8.
9. $\overline{AB} \cong \overline{CB}$	9.

22. Fill in the blanks, using the proof from #21.

a. $ABCD$ is a _____ (type of quadrilateral).

b. The line that connects the _____ and the external point B _____ $\angle ABC$.

23. Points A , B , and C are points of tangency for the three tangent circles. Explain why $\overline{AT} \cong \overline{BT} \cong \overline{CT}$.

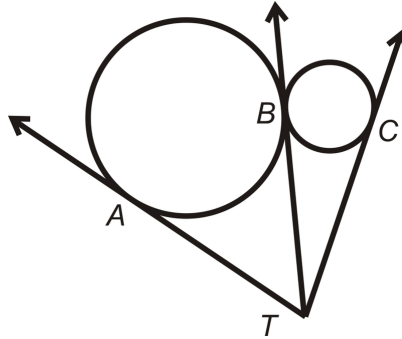

9.3 Arcs in Circles

Here you'll learn the properties of arcs and central angles and use them to find the measure of arcs.

What if a circle were divided into pieces by various radii? How could you find the measures of the arcs formed by these radii? After completing this Concept, you'll be able to use central angles to solve problems like this one.

Watch This



MEDIA

Click image to the left for more content.

[Arcs in Circles CK-12](#)

Guidance

A circle has 360° . An **arc** is a section of the circle. A **semicircle** is an arc that measures 180° .

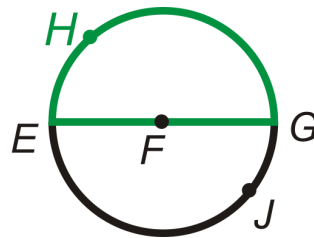

\widehat{EHG} and \widehat{EJG} are semicircles

A **central angle** is the angle formed by two radii with its vertex at the center of the circle. A **minor arc** is an arc that is less than 180° . A **major arc** is an arc that is greater than 180° . *Always* use 3 letters to label a major arc.

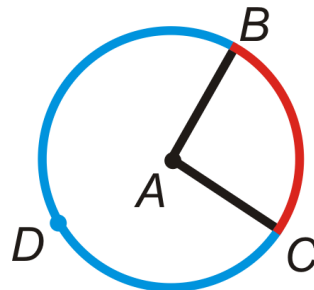

The central angle is $\angle BAC$. The minor arc is \widehat{BC} . The major arc is \widehat{BDC} .

An arc can be measured in degrees or in a linear measure (cm, ft, etc.). In this concept we will use degree measure. **The measure of a minor arc is the same as the measure of the central angle that corresponds to it.** The measure

of a major arc is 360° minus the measure of the corresponding minor arc. The measure of the arc formed by two adjacent arcs is the sum of the measures of the two arcs (**Arc Addition Postulate**).

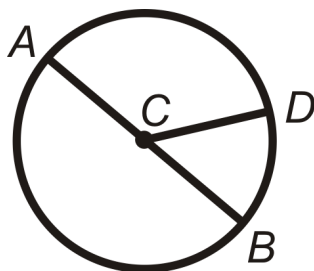

$$m\widehat{AD} + m\widehat{DB} = m\widehat{ADB}$$

Example A

Find $m\widehat{AB}$ and $m\widehat{ADB}$ in $\odot C$.

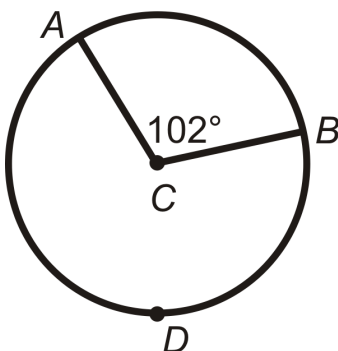

$m\widehat{AB} = m\angle ACB$. So, $m\widehat{AB} = 102^\circ$.

$$m\widehat{ADB} = 360^\circ - m\widehat{AB} = 360^\circ - 102^\circ = 258^\circ$$

Example B

Find the measures of the minor arcs in $\odot A$. \overline{EB} is a diameter.

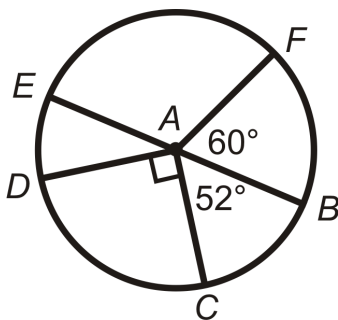

Because \overline{EB} is a diameter, $m\angle EAB = 180^\circ$. Each arc has the same measure as its corresponding central angle.

$$m\widehat{BF} = m\angle FAB = 60^\circ$$

$$m\widehat{EF} = m\angle EAF = 120^\circ \rightarrow 180^\circ - 60^\circ$$

$$m\widehat{ED} = m\angle EAD = 38^\circ \rightarrow 180^\circ - 90^\circ - 52^\circ$$

$$m\widehat{DC} = m\angle DAC = 90^\circ$$

$$m\widehat{BC} = m\angle BAC = 52^\circ$$

Example C

Find the measures of the indicated arcs in $\odot A$. \overline{EB} is a diameter.

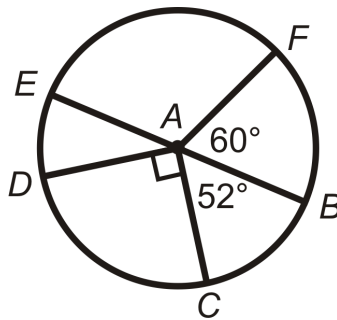

a) $m\widehat{FED}$

b) $m\widehat{CDF}$

c) $m\widehat{DFC}$

Use the Arc Addition Postulate.

a) $m\widehat{FED} = m\widehat{FE} + m\widehat{ED} = 120^\circ + 38^\circ = 158^\circ$

b) $m\widehat{CDF} = m\widehat{CD} + m\widehat{DE} + m\widehat{EF} = 90^\circ + 38^\circ + 120^\circ = 248^\circ$

c) $m\widehat{DFC} = m\widehat{ED} + m\widehat{EF} + m\widehat{FB} + m\widehat{BC} = 38^\circ + 120^\circ + 60^\circ + 52^\circ = 270^\circ$



MEDIA

Click image to the left for more content.

Arcsin Circles CK-12

Guided Practice

1. List the congruent arcs in $\odot C$ below. \overline{AB} and \overline{DE} are diameters.

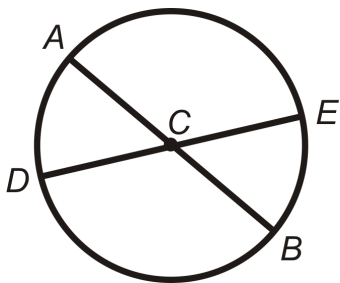

2. Are the blue arcs congruent? Explain why or why not.

a)

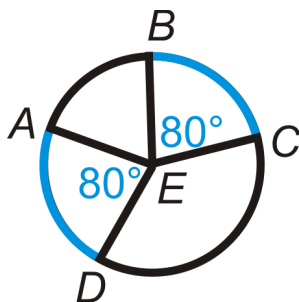

b)

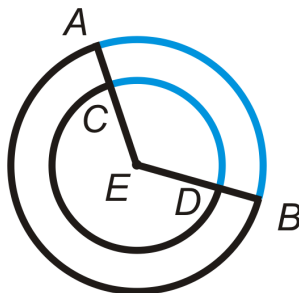

3. Find the value of x for $\odot C$ below.

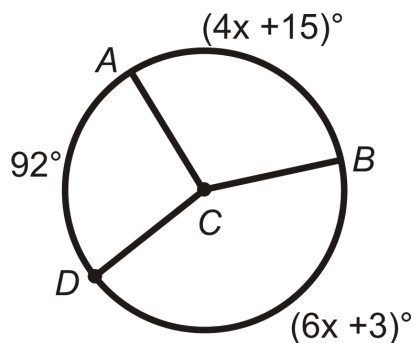

Answers:

1. $\angle ACD \cong \angle ECB$ because they are vertical angles. $\angle DCB \cong \angle ACE$ because they are also vertical angles.

$\widehat{AD} \cong \widehat{EB}$ and $\widehat{AE} \cong \widehat{DB}$

2. a) $\widehat{AD} \cong \widehat{BC}$ because they have the same central angle measure and are in the same circle.

- b) The two arcs have the same measure, but are not congruent because the circles have different radii.
3. The sum of the measure of the arcs is 360° because they make a full circle.

$$\begin{aligned} m\widehat{AB} + m\widehat{AD} + m\widehat{DB} &= 360^\circ \\ (4x + 15)^\circ + 92^\circ + (6x + 3)^\circ &= 360^\circ \\ 10x + 110^\circ &= 360^\circ \\ 10x &= 250 \\ x &= 25 \end{aligned}$$

Practice

Determine whether the arcs below are a minor arc, major arc, or semicircle of $\odot G$. \overline{EB} is a diameter.

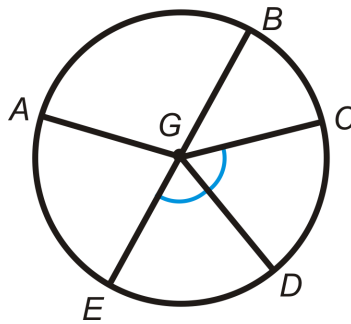

- \widehat{AB}
- \widehat{ABD}
- \widehat{BCE}
- \widehat{CAE}
- \widehat{ABC}
- \widehat{EAB}
- Are there any congruent arcs? If so, list them.
- If $m\widehat{BC} = 48^\circ$, find $m\widehat{CD}$.
- Using #8, find $m\widehat{CAE}$.

Find the measure of the minor arc and the major arc in each circle below.

- 10.
- 11.

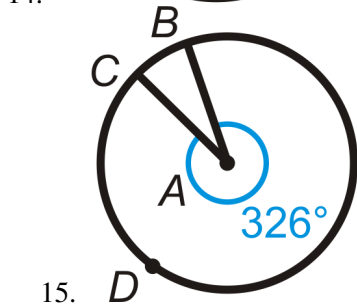
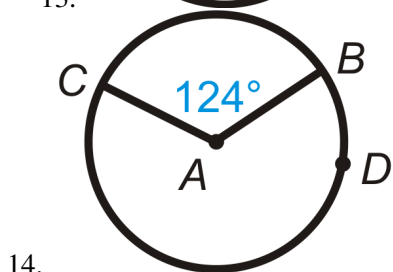
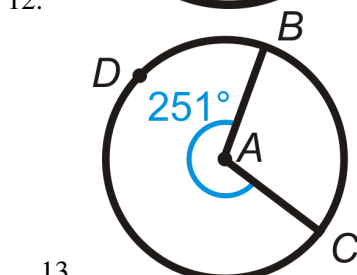
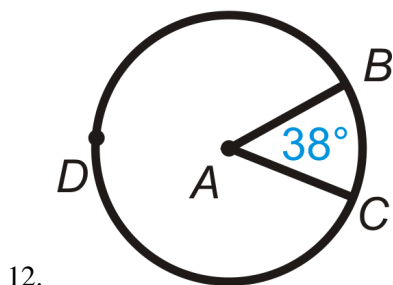

Determine if the blue arcs are congruent. If so, state why.

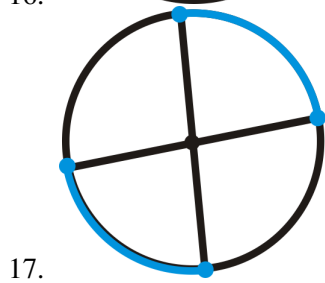
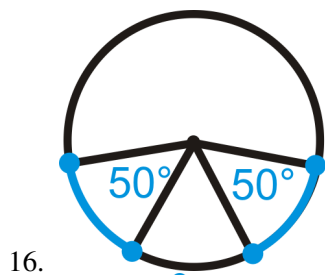

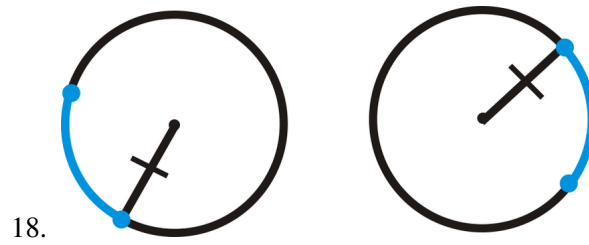

Find the measure of the indicated arcs or central angles in $\odot A$. \overline{DG} is a diameter.

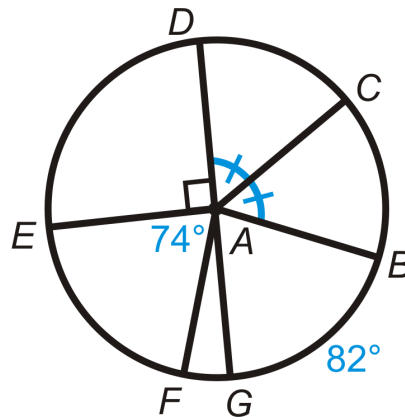

19. \widehat{DE}
20. \widehat{DC}
21. \widehat{GAB}
22. \widehat{FG}
23. \widehat{EDB}
24. \widehat{EAB}
25. \widehat{DCF}
26. \widehat{DBE}

Find the measure of x in $\odot P$.

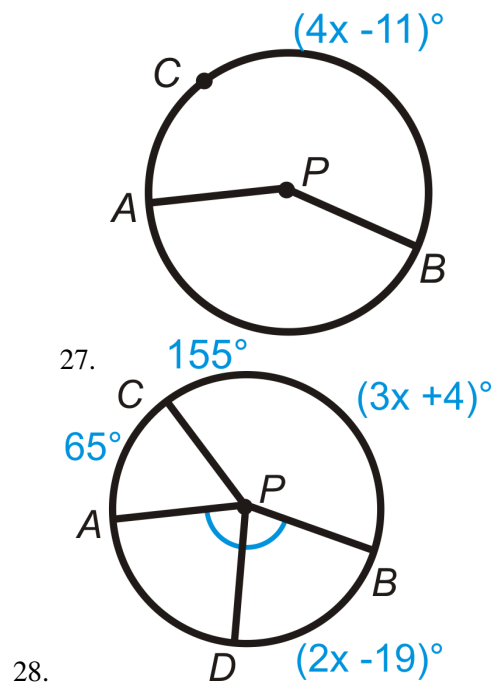

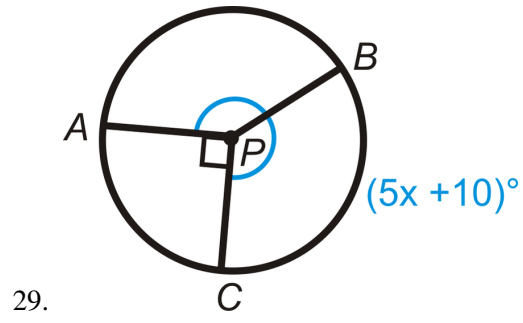

9.4 Chords in Circles

Here you'll learn four theorems about chords in circles and how to apply them to find missing values.

What if you were given a circle with two chords drawn through it? How could you determine if these two chords were congruent? After completing this Concept, you'll be able to use four chord theorems to solve problems like this one.

Watch This



MEDIA

Click image to the left for more content.

[Chords in Circles CK-12](#)

Guidance

There are several important theorems about chords that will help you to analyze circles better.

1) **Chord Theorem #1:** In the same circle or congruent circles, minor arcs are congruent if and only if their corresponding chords are congruent.

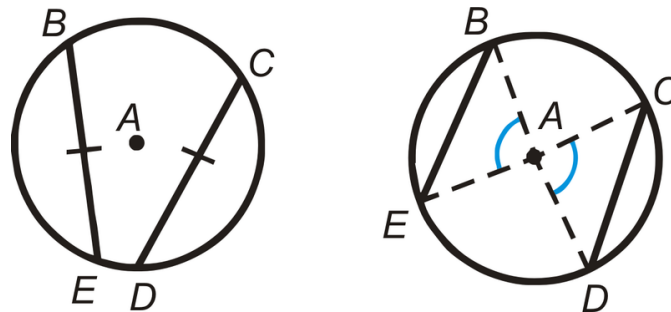

In both of these pictures, $\overline{BE} \cong \overline{CD}$ and $\widehat{BE} \cong \widehat{CD}$.

2) **Chord Theorem #2:** The perpendicular bisector of a chord is also a diameter.

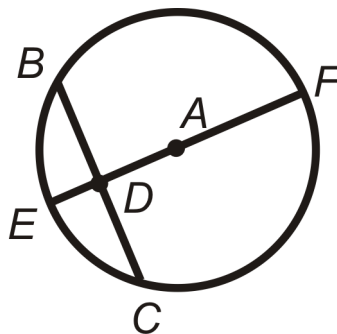

If $\overline{AD} \perp \overline{BC}$ and $\overline{BD} \cong \overline{DC}$ then \overline{EF} is a diameter.

3) **Chord Theorem #3:** If a diameter is perpendicular to a chord, then the diameter bisects the chord and its corresponding arc.

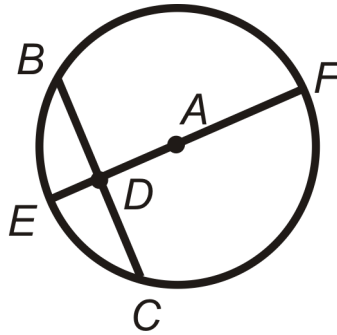

If $\overline{EF} \perp \overline{BC}$, then $\overline{BD} \cong \overline{DC}$ and $\widehat{BE} \cong \widehat{EC}$.

4) **Chord Theorem #4:** In the same circle or congruent circles, two chords are congruent if and only if they are equidistant from the center.

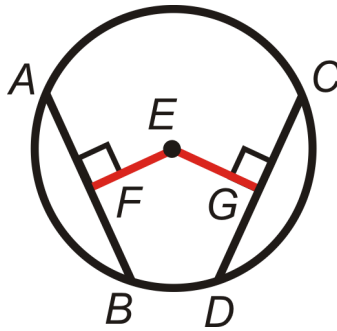

The shortest distance from any point to a line is the perpendicular line between them. If $FE = EG$ and $\overline{EF} \perp \overline{EG}$, then \overline{AB} and \overline{CD} are equidistant to the center and $\overline{AB} \cong \overline{CD}$.

Example A

Use $\odot A$ to answer the following.

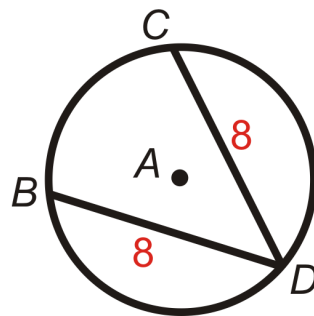

- a) If $m\widehat{BD} = 125^\circ$, find $m\widehat{CD}$.
- b) If $m\widehat{BC} = 80^\circ$, find $m\widehat{CD}$.

Answers:

a) $BD = CD$, which means the arcs are congruent too. $m\widehat{CD} = 125^\circ$.

b) $m\widehat{CD} \cong m\widehat{BD}$ because $BD = CD$.

$$m\widehat{BC} + m\widehat{CD} + m\widehat{BD} = 360^\circ$$

$$80^\circ + 2m\widehat{CD} = 360^\circ$$

$$2m\widehat{CD} = 280^\circ$$

$$m\widehat{CD} = 140^\circ$$

Example B

Find the values of x and y .

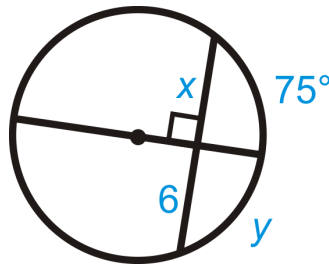

The diameter is perpendicular to the chord. From Chord Theorem #3, $x = 6$ and $y = 75^\circ$.

Example C

Find the value of x .

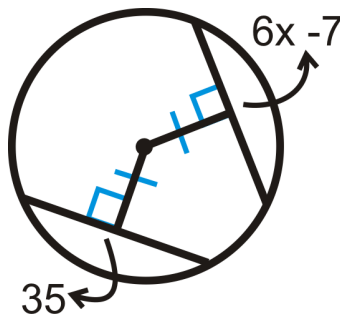

Because the distance from the center to the chords is equal, the chords are congruent.

$$6x - 7 = 35$$

$$6x = 42$$

$$x = 7$$



MEDIA

Click image to the left for more content.

Chords in Circles CK-12

Guided Practice

1. Find the value of x and y .

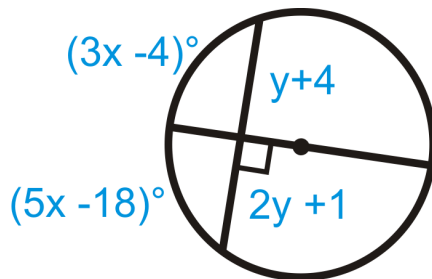

2. $BD = 12$ and $AC = 3$ in $\odot A$. Find the radius.

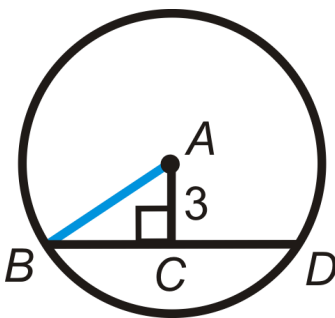

3. Find $m\widehat{BD}$ from #2.

Answers:

1. The diameter is perpendicular to the chord, which means it bisects the chord and the arc. Set up equations for x and y .

$$\begin{aligned} (3x - 4)^\circ &= (5x - 18)^\circ & y + 4 &= 2y + 1 \\ 14 &= 2x & 3 &= y \\ 7 &= x & & \end{aligned}$$

2. First find the radius. \overline{AB} is a radius, so we can use the right triangle $\triangle ABC$ with hypotenuse \overline{AB} . From Chord Theorem #3, $BC = 6$.

$$\begin{aligned} 3^2 + 6^2 &= AB^2 \\ 9 + 36 &= AB^2 \\ AB &= \sqrt{45} = 3\sqrt{5} \end{aligned}$$

3. First, find the corresponding central angle, $\angle BAD$. We can find $m\angle BAC$ using the tangent ratio. Then, multiply $m\angle BAC$ by 2 for $m\angle BAD$ and $m\widehat{BD}$.

$$\begin{aligned} \tan^{-1}\left(\frac{6}{3}\right) &= m\angle BAC \\ m\angle BAC &\approx 63.43^\circ \\ m\angle BAD &\approx 2 \cdot 63.43^\circ \approx 126.86^\circ \approx m\widehat{BD} \end{aligned}$$

Practice

Fill in the blanks.

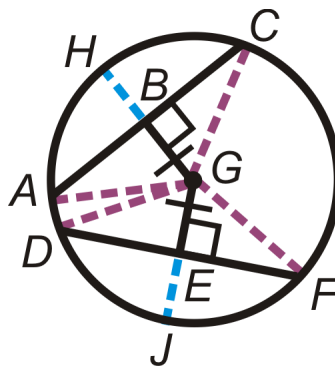

1. $\underline{\hspace{1cm}} \cong \overline{DF}$
2. $\widehat{AC} \cong \underline{\hspace{1cm}}$
3. $\widehat{DJ} \cong \underline{\hspace{1cm}}$
4. $\underline{\hspace{1cm}} \cong \overline{EJ}$
5. $\angle AGH \cong \underline{\hspace{1cm}}$
6. $\angle DGF \cong \underline{\hspace{1cm}}$
7. List all the congruent radii in $\odot G$.

Find the value of the indicated arc in $\odot A$.

8. $m\widehat{BC}$

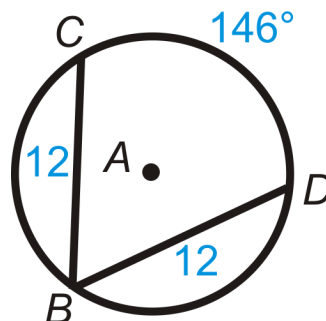

9. $m\widehat{BD}$

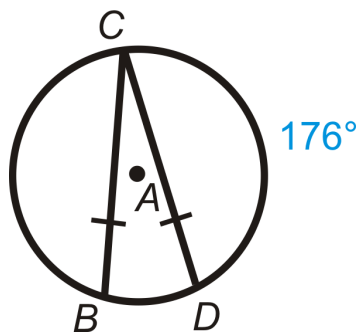

10. $m\widehat{BC}$

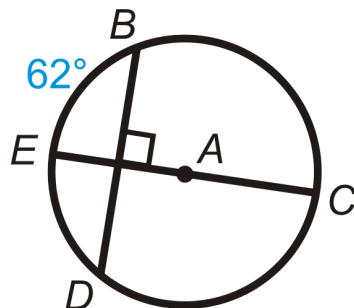

11. $m\widehat{BD}$

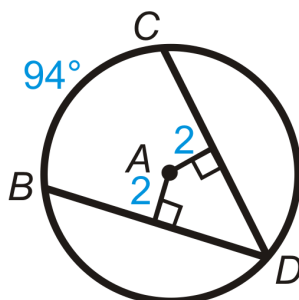

12. $m\widehat{BD}$

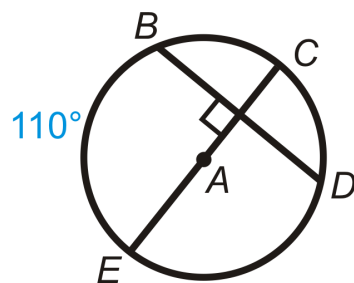

13. $m\widehat{BD}$

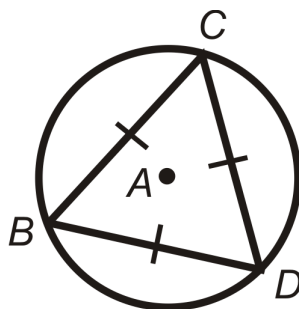

Find the value of x and/or y .

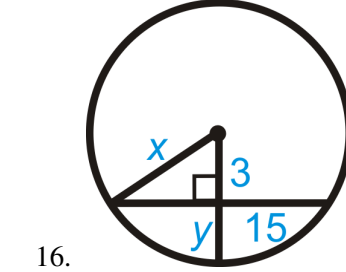
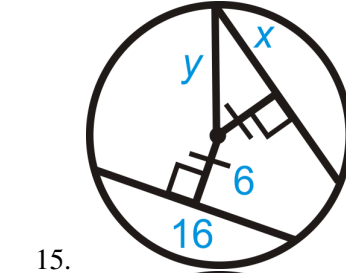
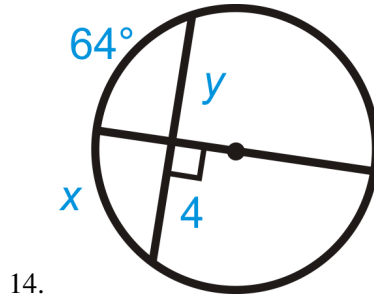

17. $AB = 32$

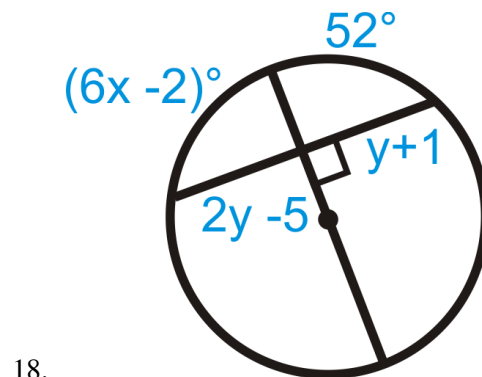
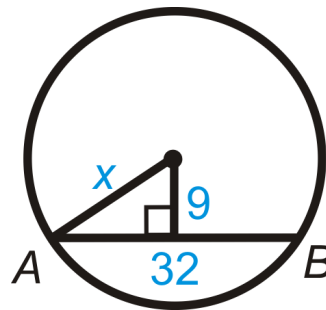

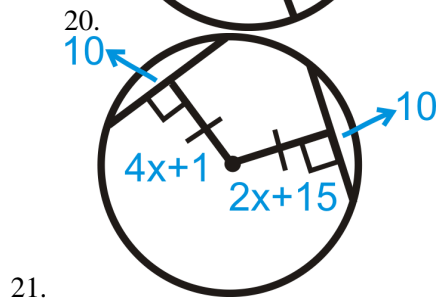
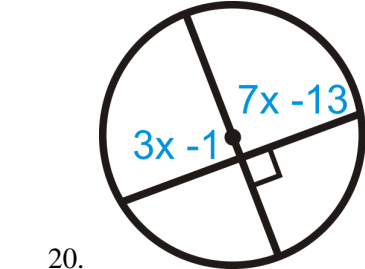
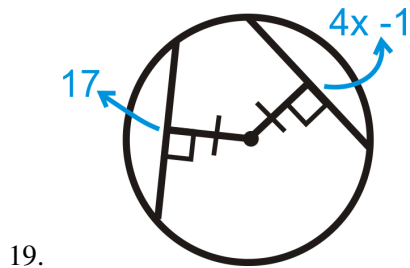

22. $AB = 20$

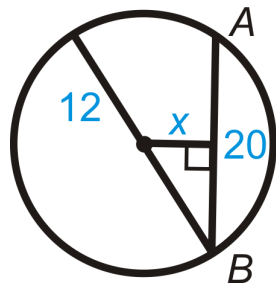

23. Find $m\widehat{AB}$ in Question 17. Round your answer to the nearest tenth of a degree.

24. Find $m\widehat{AB}$ in Question 22. Round your answer to the nearest tenth of a degree.

In problems 25-27, what can you conclude about the picture? State a theorem that justifies your answer. You may assume that A is the center of the circle.

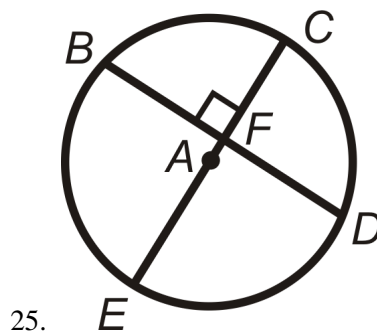

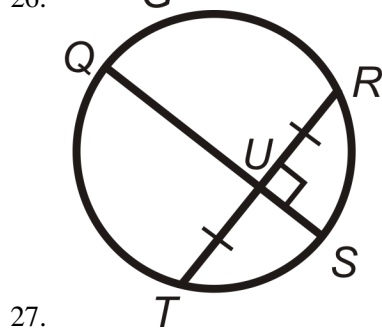
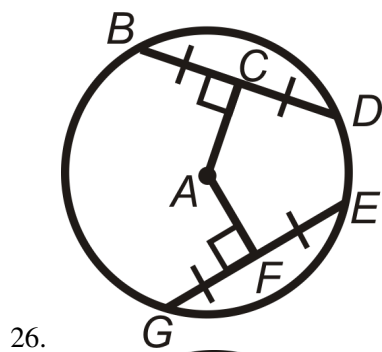

9.5 Inscribed Angles in Circles

Here you'll learn the Inscribed Angle Theorem, which states that the measure of an inscribed angle is half the measure of its intercepted arc. You'll also learn other inscribed angle theorems and you'll use them to solve problems about circles.

What if you had a circle with two chords that share a common endpoint? How could you use the arc formed by those chords to determine the measure of the angle those chords make inside the circle? After completing this Concept, you'll be able to use the Inscribed Angle Theorem to solve problems like this one.

Watch This



MEDIA

Click image to the left for more content.

[Inscribed Angles in Circles CK-12](#)

Guidance

An **inscribed angle** is an angle with its vertex on the circle and whose sides are chords. The **intercepted arc** is the arc that is inside the inscribed angle and whose endpoints are on the angle. The vertex of an inscribed angle can be anywhere on the circle as long as its sides intersect the circle to form an intercepted arc.

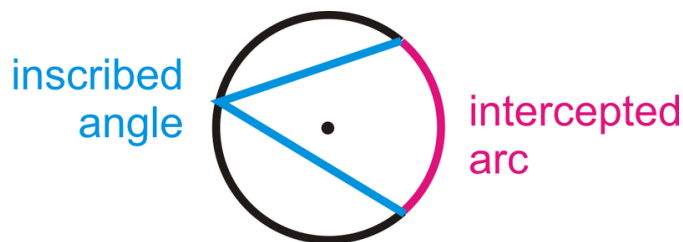

The **Inscribed Angle Theorem** states that the measure of an inscribed angle is half the measure of its intercepted arc.

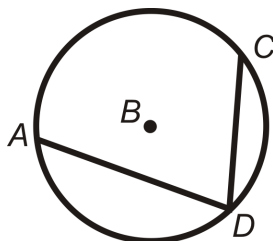

$$m\angle ADC = \frac{1}{2}m\widehat{AC} \text{ and } m\widehat{AC} = 2m\angle ADC$$

Inscribed angles that intercept the same arc are congruent. This is called the **Congruent Inscribed Angles Theorem** and is shown below.

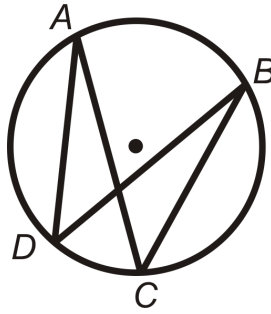

$\angle ADB$ and $\angle ACB$ intercept \widehat{AB} , so $m\angle ADB = m\angle ACB$. Similarly, $\angle DAC$ and $\angle DBC$ intercept \widehat{DC} , so $m\angle DAC = m\angle DBC$.

An angle intercepts a semicircle if and only if it is a right angle (**Semicircle Theorem**). *Anytime a right angle is inscribed in a circle, the endpoints of the angle are the endpoints of a diameter and the diameter is the hypotenuse.*



MEDIA

Click image to the left for more content.

$\angle DAB$ intercepts a semicircle, so $m\angle DAB = 90^\circ$. $\angle DAB$ is a right angle, so \widehat{DB} is a semicircle.

Example A

Find $m\widehat{DC}$ and $m\angle ADB$.

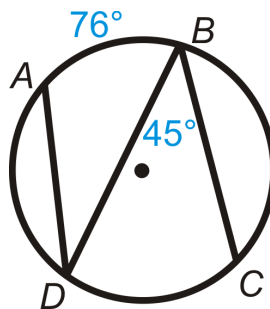

From the Inscribed Angle Theorem:

$$m\widehat{DC} = 2 \cdot 45^\circ = 90^\circ$$

$$m\angle ADB = \frac{1}{2} \cdot 76^\circ = 38^\circ$$

Example B

Find $m\angle ADB$ and $m\angle ACB$.

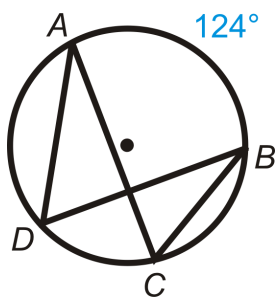

The intercepted arc for both angles is \widehat{AB} . Therefore,

$$m\angle ADB = \frac{1}{2} \cdot 124^\circ = 62^\circ$$

$$m\angle ACB = \frac{1}{2} \cdot 124^\circ = 62^\circ$$

Example C

Find $m\angle DAB$ in $\odot C$.

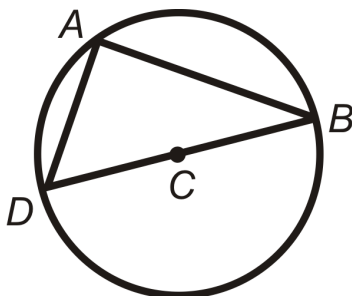

C is the center, so \overline{DB} is a diameter. $\angle DAB$'s endpoints are on the diameter, so the central angle is 180° .

$$m\angle DAB = \frac{1}{2} \cdot 180^\circ = 90^\circ.$$



MEDIA

Click image to the left for more content.

Guided Practice

1. Find $m\angle PMN$, $m\widehat{PN}$, $m\angle MNP$, and $m\angle LNP$.

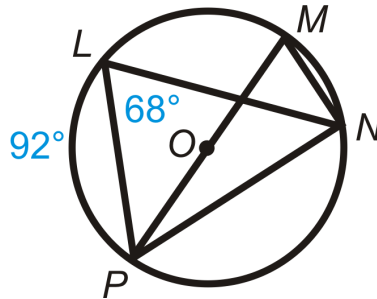

2. Fill in the blank: An inscribed angle is _____ the measure of the intercepted arc.
 3. Fill in the blank: A central angle is _____ the measure of the intercepted arc.

Answers:

1. Use what you've learned about inscribed angles.

$$\begin{aligned}
 m\angle PMN &= m\angle PLN = 68^\circ && \text{by the Congruent Inscribed Angles Theorem.} \\
 m\widehat{PN} &= 2 \cdot 68^\circ = 136^\circ && \text{from the Inscribed Angle Theorem.} \\
 m\angle MNP &= 90^\circ && \text{by the Semicircle Theorem.} \\
 m\angle LNP &= \frac{1}{2} \cdot 92^\circ = 46^\circ && \text{from the Inscribed Angle Theorem.}
 \end{aligned}$$

2. half
 3. equal to

Practice

Fill in the blanks.

- An angle inscribed in a _____ is 90° .
- Two inscribed angles that intercept the same arc are _____.
- The sides of an inscribed angle are _____.
- Draw inscribed angle $\angle JKL$ in $\odot M$. Then draw central angle $\angle JML$. How do the two angles relate?

Find the value of x and/or y in $\odot A$.

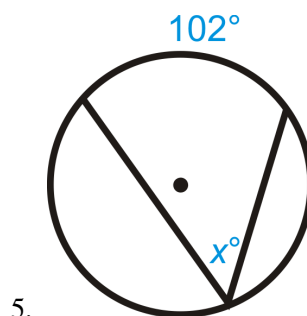

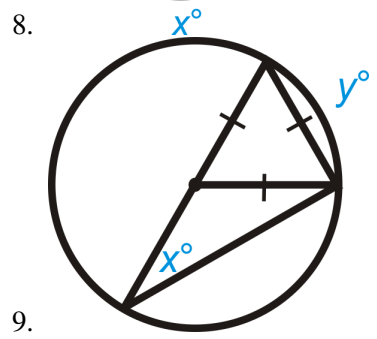
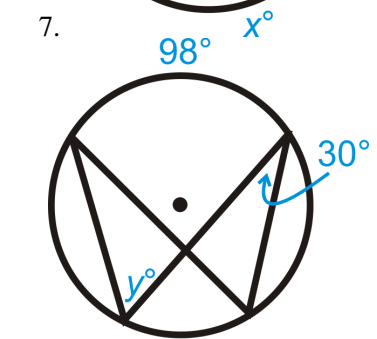
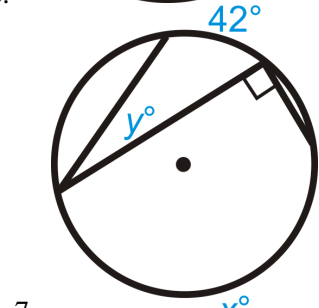
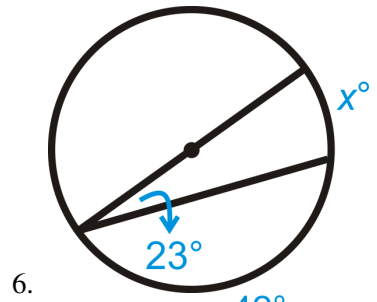

Solve for x .

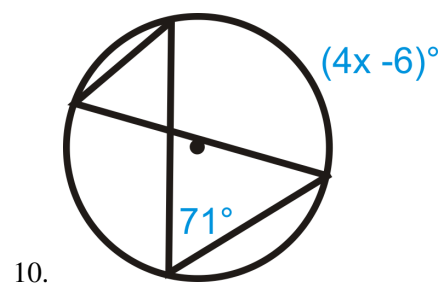

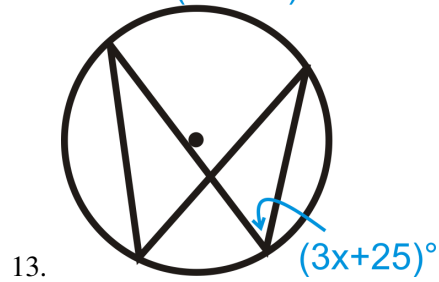
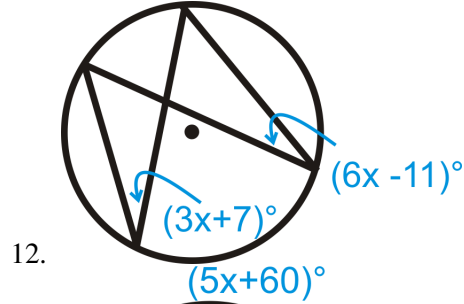
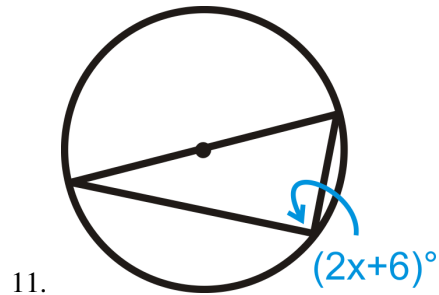

14. Fill in the blanks of the Inscribed Angle Theorem proof.

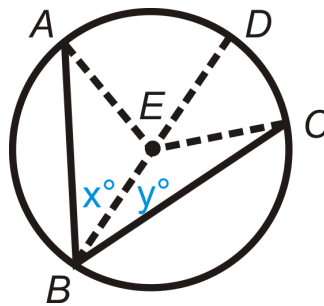

Given: Inscribed $\angle ABC$ and diameter \overline{BD}

Prove: $m\angle ABC = \frac{1}{2}m\widehat{AC}$

TABLE 9.2:

Statement

1. Inscribed $\angle ABC$ and diameter \overline{BD}
 $m\angle ABE = x^\circ$ and $m\angle CBE = y^\circ$
2. $x^\circ + y^\circ = m\angle ABC$
- 3.
- 4.
5. $m\angle EAB = x^\circ$ and $m\angle ECB = y^\circ$
6. $m\angle AED = 2x^\circ$ and $m\angle CED = 2y^\circ$
7. $m\widehat{AD} = 2x^\circ$ and $m\widehat{DC} = 2y^\circ$
- 8.
9. $m\widehat{AC} = 2x^\circ + 2y^\circ$

Reason

- 1.
- 2.
3. All radii are congruent
4. Definition of an isosceles triangle
- 5.
- 6.
- 7.
8. Arc Addition Postulate
- 9.

TABLE 9.2: (continued)

<i>Statement</i>	<i>Reason</i>
10.	10. Distributive PoE
11. $m\widehat{AC} = 2m\angle ABC$	11.
12. $m\angle ABC = \frac{1}{2}m\widehat{AC}$	12.

9.6 Inscribed Quadrilaterals in Circles

Here you'll learn about inscribed quadrilaterals and how to use the Inscribed Quadrilateral Theorem to solve problems about circles.

What if you were given a circle with a quadrilateral inscribed in it? How could you use information about the arcs formed by the quadrilateral and/or the quadrilateral's angle measures to find the measure of the unknown quadrilateral angles? After completing this Concept, you'll be able to apply the Inscribed Quadrilateral Theorem to solve problems like this one.

Watch This



MEDIA

Click image to the left for more content.

Inscribed Quadrilaterals in Circles CK-12

Guidance

An **inscribed polygon** is a polygon where every vertex is on the circle, as shown below.

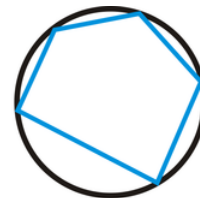
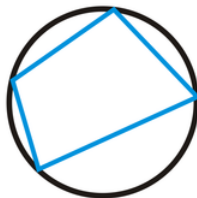
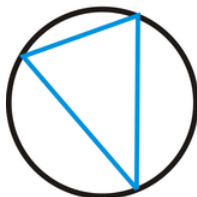

For inscribed quadrilaterals in particular, the opposite angles will always be supplementary.

Inscribed Quadrilateral Theorem: A quadrilateral can be inscribed in a circle if and only if the opposite angles are supplementary.

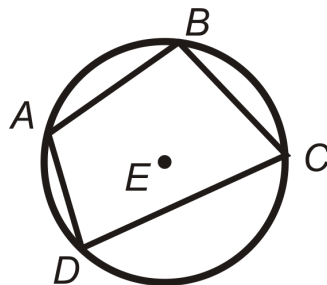

If $ABCD$ is inscribed in $\odot E$, then $m\angle A + m\angle C = 180^\circ$ and $m\angle B + m\angle D = 180^\circ$. Conversely, If $m\angle A + m\angle C = 180^\circ$ and $m\angle B + m\angle D = 180^\circ$, then $ABCD$ is inscribed in $\odot E$.

Example A

Find the values of the missing variables.

a)

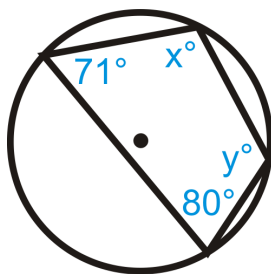

b)

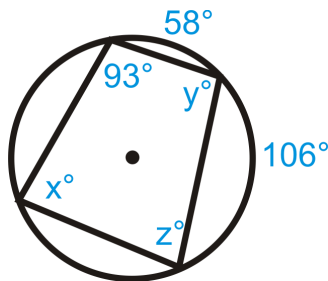

Answers:

a)

$$x + 80^\circ = 180^\circ$$

$$x = 100^\circ$$

$$y + 71^\circ = 180^\circ$$

$$y = 109^\circ$$

b)

$$z + 93^\circ = 180^\circ$$

$$z = 87^\circ$$

$$x = \frac{1}{2}(58^\circ + 106^\circ)$$

$$x = 82^\circ$$

$$y + 82^\circ = 180^\circ$$

$$y = 98^\circ$$

Example B

Find x and y in the picture below.

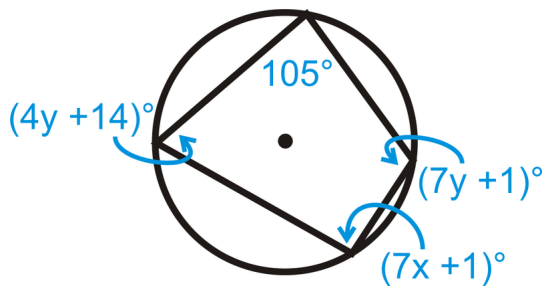

$$(7x + 1)^\circ + 105^\circ = 180^\circ$$

$$7x + 106^\circ = 180^\circ$$

$$7x = 74$$

$$x = 10.57$$

$$(4y + 14)^\circ + (7y + 1)^\circ = 180^\circ$$

$$11y + 15^\circ = 180^\circ$$

$$11y = 165$$

$$y = 15$$

Example C

Find the values of x and y in $\odot A$.

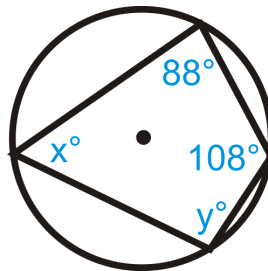

Use the Inscribed Quadrilateral Theorem. $x^\circ + 108^\circ = 180^\circ$ so $x = 72^\circ$. Similarly, $y^\circ + 88^\circ = 180^\circ$ so $y = 92^\circ$.

**MEDIA**

Click image to the left for more content.

Inscribed Quadrilaterals in Circles CK-12

Guided Practice

Quadrilateral $ABCD$ is inscribed in $\odot E$. Find:

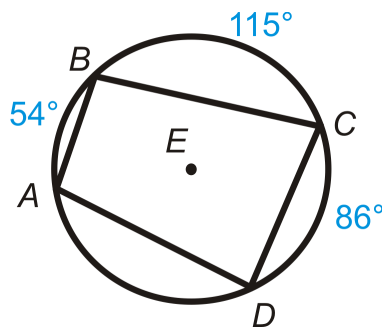

1. $m\angle A$
2. $m\angle B$
3. $m\angle C$
4. $m\angle D$

Answers:

First, note that $m\widehat{AD} = 105^\circ$ because the complete circle must add up to 360° .

1. $m\angle A = \frac{1}{2}m\widehat{BD} = \frac{1}{2}(115 + 86) = 100.5^\circ$
2. $m\angle B = \frac{1}{2}m\widehat{AC} = \frac{1}{2}(86 + 105) = 95.5^\circ$
3. $m\angle C = 180^\circ - m\angle A = 180^\circ - 100.5^\circ = 79.5^\circ$
4. $m\angle D = 180^\circ - m\angle B = 180^\circ - 95.5^\circ = 84.5^\circ$

Practice

Fill in the blanks.

1. A(n) _____ polygon has all its vertices on a circle.
2. The _____ angles of an inscribed quadrilateral are _____.

Quadrilateral $ABCD$ is inscribed in $\odot E$. Find:

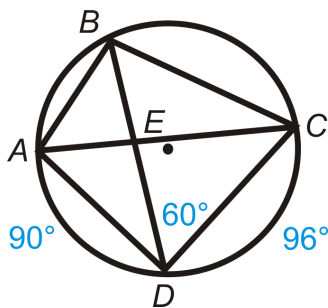

3. $m\angle DBC$
4. $m\widehat{BC}$
5. $m\widehat{AB}$
6. $m\angle ACD$
7. $m\angle ADC$
8. $m\angle ACB$

Find the value of x and/or y in $\odot A$.

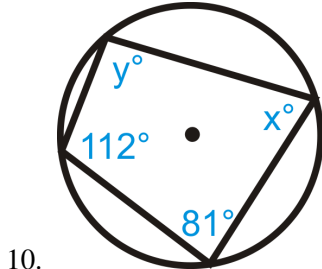
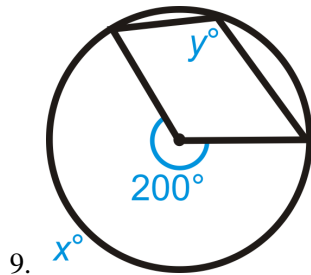

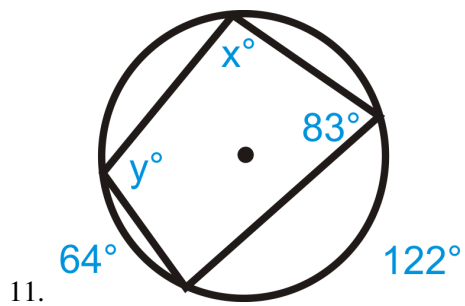

Solve for x .

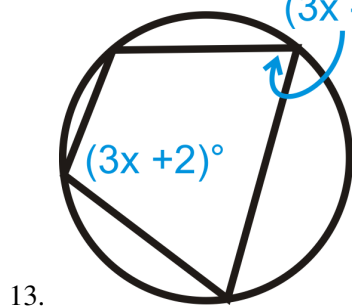
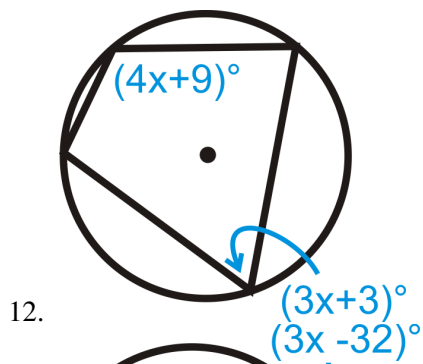

9.7 Angles On and Inside a Circle

Here you'll learn how to use the Chord/Tangent Angle Theorem and the Intersecting Chords Angle Theorem to solve problems containing angles that are on or inside a circle.

What if you were given a circle with either a chord and a tangent or two chords that meet at a common point? How could you use the measure of the arc(s) formed by those circle parts to find the measure of the angles they make on or inside the circle? After completing this Concept, you'll be able to apply the Chord/Tangent Angle Theorem and the Intersecting Chords Angle Theorem to solve problems like this one.

Watch This



MEDIA

Click image to the left for more content.

Angles On and Inside a Circle CK-12

Guidance

When we say an angle is *on* a circle, we mean the vertex is on the edge of the circle. One type of angle *on* a circle is the inscribed angle (see [Inscribed Angles in Circles](#)). Another type of angle *on* a circle is one formed by a tangent and a chord.

Chord/Tangent Angle Theorem: The measure of an angle formed by a chord and a tangent that intersect on a circle is half the measure of the intercepted arc.

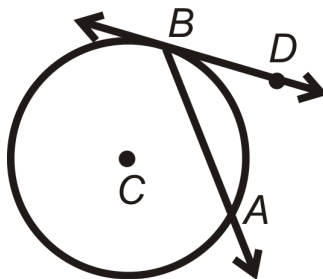

$$m\angle DBA = \frac{1}{2}m\widehat{AB}$$

If two angles, with their vertices on the circle, intercept the same arc then the angles are congruent.

An angle is *inside* a circle when the vertex lies anywhere inside the circle.

Intersecting Chords Angle Theorem: The measure of the angle formed by two chords that intersect *inside* a circle is the average of the measures of the intercepted arcs.

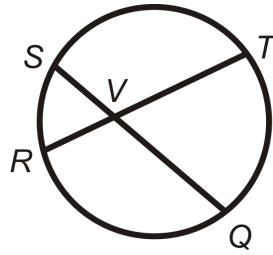

$$m\angle SVR = \frac{1}{2} (m\widehat{SR} + m\widehat{TQ}) = \frac{m\widehat{SR} + m\widehat{TQ}}{2} = m\angle TVQ$$

$$m\angle SVT = \frac{1}{2} (m\widehat{ST} + m\widehat{RQ}) = \frac{m\widehat{ST} + m\widehat{RQ}}{2} = m\angle RVQ$$

Example A

Find $m\angle BAD$.

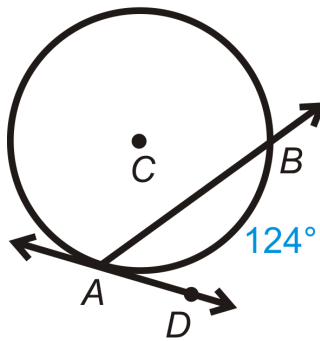

Use the Chord/Tangent Angle Theorem. $m\angle BAD = \frac{1}{2}m\widehat{AB} = \frac{1}{2} \cdot 124^\circ = 62^\circ$.

Example B

Find a , b , and c .

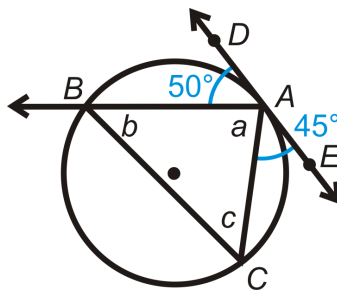

$$50^\circ + 45^\circ + m\angle a = 180^\circ \quad \text{straight angle}$$

$$m\angle a = 85^\circ$$

$$m\angle b = \frac{1}{2} \cdot m\widehat{AC}$$

$$m\widehat{AC} = 2 \cdot m\angle EAC = 2 \cdot 45^\circ = 90^\circ$$

$$m\angle b = \frac{1}{2} \cdot 90^\circ = 45^\circ$$

$$85^\circ + 45^\circ + m\angle c = 180^\circ \quad \text{Triangle Sum Theorem}$$

$$m\angle c = 50^\circ$$

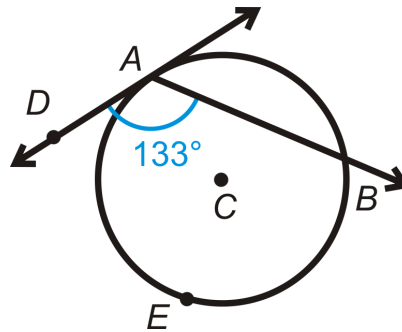
Example CFind $m\widehat{AEB}$.Use the Chord/Tangent Angle Theorem. $m\widehat{AEB} = 2 \cdot m\angle DAB = 2 \cdot 133^\circ = 266^\circ$.**MEDIA**

Click image to the left for more content.

[Angles On and Insidea Circle CK-12](#)**Guided Practice**Find x .

1.

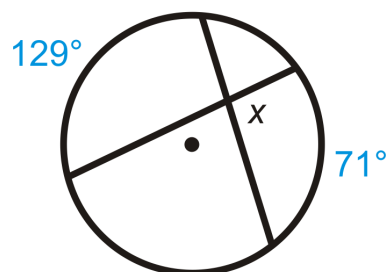

2.

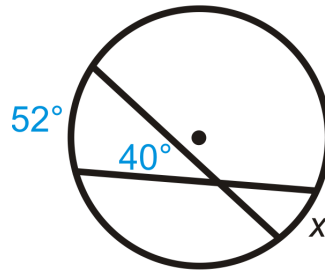

3.

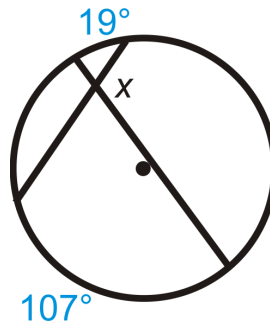

Answers:

Use the Intersecting Chords Angle Theorem to write an equation.

1. $x = \frac{129^\circ + 71^\circ}{2} = \frac{200^\circ}{2} = 100^\circ$

2.

$$40^\circ = \frac{52^\circ + x}{2}$$

$$80^\circ = 52^\circ + x$$

$$28^\circ = x$$

3. x is supplementary to the angle that is the average of the given intercepted arcs. We call this supplementary angle y .

$$y = \frac{19^\circ + 107^\circ}{2} = \frac{126^\circ}{2} = 63^\circ \quad x + 63^\circ = 180^\circ; x = 117^\circ$$

Practice

Find the value of the missing variable(s).

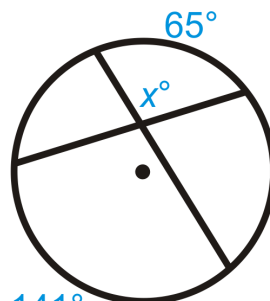

1. 141°

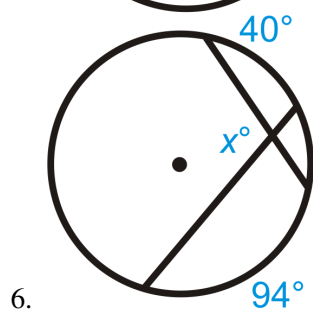
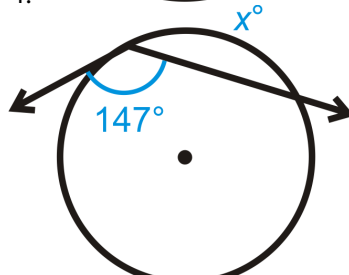
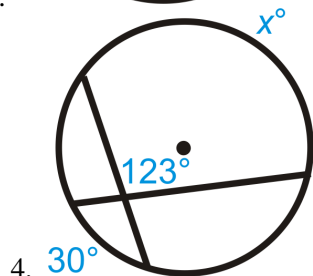
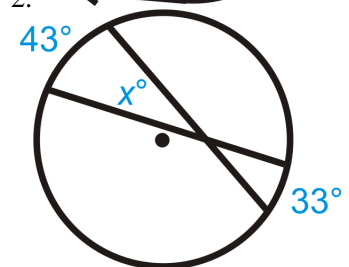
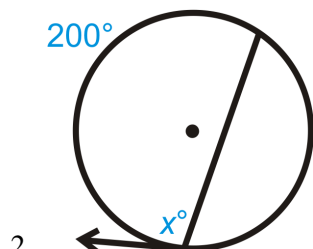

7. $y \neq 60^\circ$

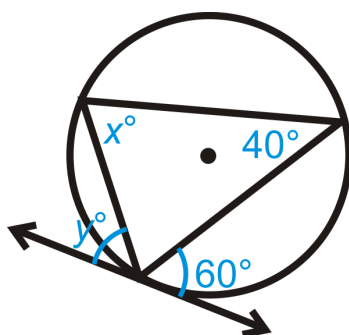

Solve for x .

8. Fill in the blanks of the proof for the Intersecting Chords Angle Theorem

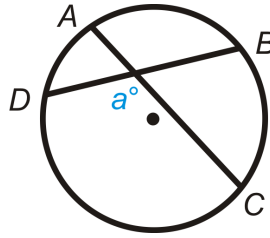

Given: Intersecting chords \overline{AC} and \overline{BD} .

Prove: $m\angle a = \frac{1}{2}(m\widehat{DC} + m\widehat{AB})$

TABLE 9.3:

Statement

1. Intersecting chords \overline{AC} and \overline{BD} .
2. Draw \overline{BC}

Reason

- 1.
2. Construction

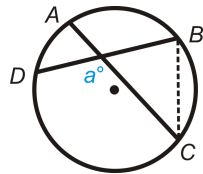

3.
$$m\angle DBC = \frac{1}{2}m\widehat{DC}$$

$$m\angle ACB = \frac{1}{2}m\widehat{AB}$$

3.

4. $m\angle a = m\angle DBC + m\angle ACB$

4.

5. $m\angle a = \frac{1}{2}m\widehat{DC} + \frac{1}{2}m\widehat{AB}$

5.

Fill in the blanks.

9. If the vertex of an angle is _____ a circle, then its measure is the average of the _____ - _____ arcs.
10. If the vertex of an angle is _____ a circle, then its measure is _____ the intercepted arc.

9.8 Angles Outside a Circle

Here you'll learn how to use the Outside Angle Theorem to solve problems containing angles that are outside a circle.

What if you were given a circle with either two secants, two tangents, or one of each that share a common point outside the circle? How could you use the measure of the arcs formed by those circle parts to find the measure of the angle they make outside the circle? After completing this Concept, you'll be able to apply the Outside Angle Theorem to solve problems like this one.

Watch This



MEDIA

Click image to the left for more content.

Angles Outside a Circle CK-12

Guidance

An angle is *outside* a circle if its vertex is outside the circle and its sides are tangents or secants. The possibilities are: an angle formed by two tangents, an angle formed by a tangent and a secant, and an angle formed by two secants.

Outside Angle Theorem: The measure of an angle formed by two secants, two tangents, or a secant and a tangent from a point outside the circle is half the difference of the measures of the intercepted arcs.

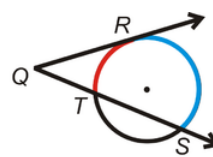
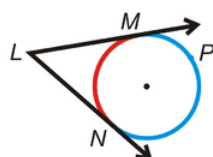
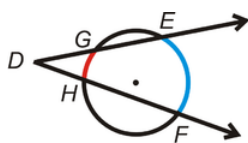

$$m\angle D = \frac{m\widehat{EF} - m\widehat{GH}}{2}, m\angle L = \frac{m\widehat{MPN} - m\widehat{MN}}{2}, m\angle Q = \frac{m\widehat{RS} - m\widehat{RT}}{2}$$

Example A

Find the value of x .

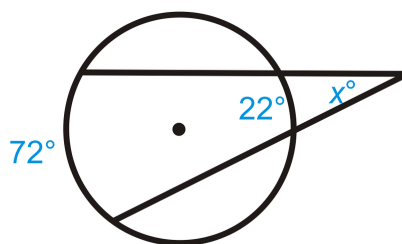

$$x = \frac{72^\circ - 22^\circ}{2} = \frac{50^\circ}{2} = 25^\circ.$$

Example B

Find the value of x .

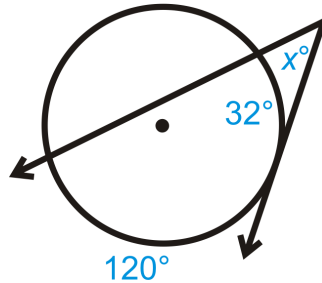

$$x = \frac{120^\circ - 32^\circ}{2} = \frac{88^\circ}{2} = 44^\circ.$$

Example C

Find the value of x .

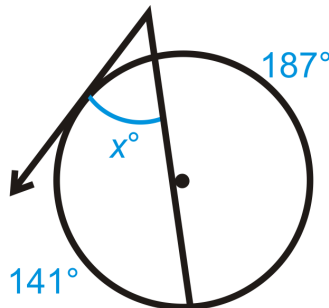

First note that the missing arc by angle x measures 32° because the complete circle must make 360° . Then, $x = \frac{141^\circ - 32^\circ}{2} = \frac{109^\circ}{2} = 54.5^\circ$.



MEDIA

Click image to the left for more content.

[Angles Outside a Circle CK-12](#)

Guided Practice

Find the measure of x .

1.

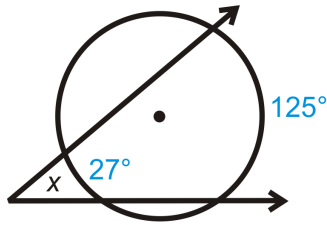

2.

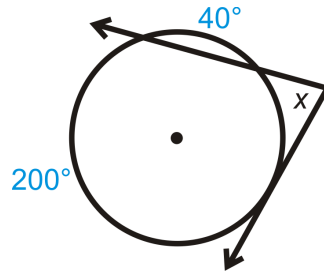

3.

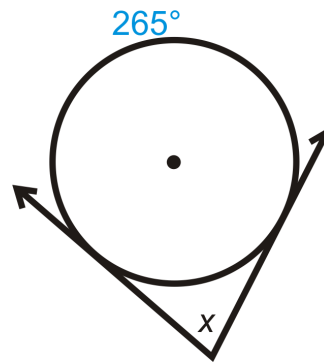

Answers:

For all of the above problems we can use the Outside Angle Theorem.

1. $x = \frac{125^\circ - 27^\circ}{2} = \frac{98^\circ}{2} = 49^\circ$

2. 40° is not the intercepted arc. The intercepted arc is 120° , $(360^\circ - 200^\circ - 40^\circ)$. $x = \frac{200^\circ - 120^\circ}{2} = \frac{80^\circ}{2} = 40^\circ$

3. Find the other intercepted arc, $360^\circ - 265^\circ = 95^\circ$. $x = \frac{265^\circ - 95^\circ}{2} = \frac{170^\circ}{2} = 85^\circ$

Practice

Find the value of the missing variable(s).

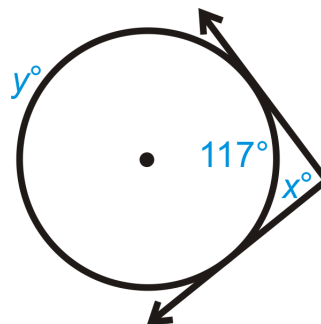

1.

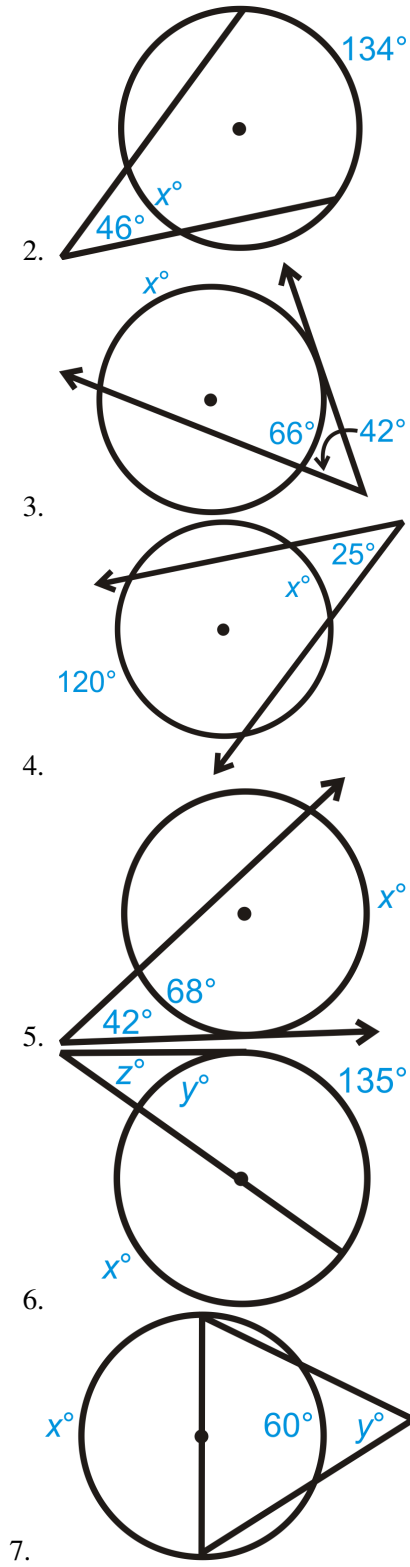

Solve for x .

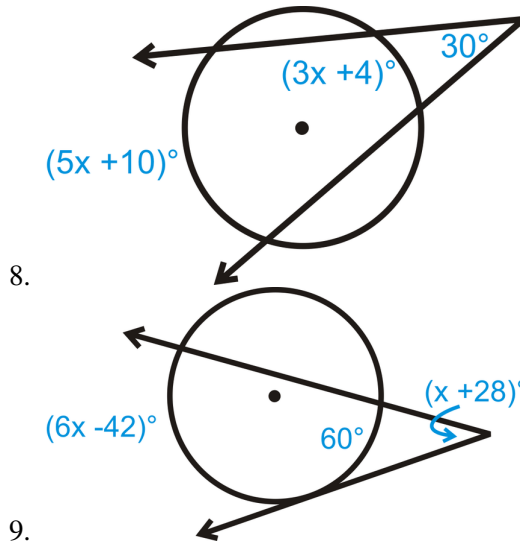

10. Fill in the blanks of the proof for the Outside Angle Theorem

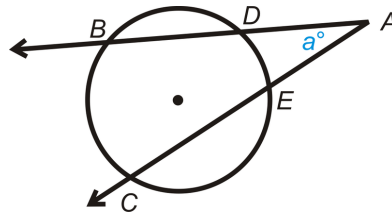

Given: Secant rays \vec{AB} and \vec{AC}

Prove: $m\angle a = \frac{1}{2}(m\widehat{BC} - m\widehat{DE})$

TABLE 9.4:

Statement

1. Intersecting secants \vec{AB} and \vec{AC} .
2. Draw \overline{BE} .

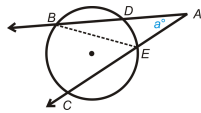

Reason

- 1.
2. Construction

3. $m\angle BEC = \frac{1}{2}m\widehat{BC}$

$m\angle DBE = \frac{1}{2}m\widehat{DE}$

4. $m\angle a + m\angle DBE = m\angle BEC$

5.

6.

7. $m\angle a = \frac{1}{2}(m\widehat{BC} - m\widehat{DE})$

3.

4.

5. Subtraction PoE

6. Substitution

7.

9.9 Segments from Chords

Here you'll learn the relationship that exists between two chords when they intersect to solve for unknown circle values.

What if you were given a circle with two chords that intersect each other? How could you use the length of some of the segments formed by their intersection to determine the lengths of the unknown segments? After completing this Concept, you'll be able to use the Intersecting Chords Theorem to solve problems like this one.

Watch This



MEDIA

Click image to the left for more content.

[Segments from Chords CK-12](#)

Guidance

When we have two chords that intersect inside a circle, as shown below, the two triangles that result are similar.

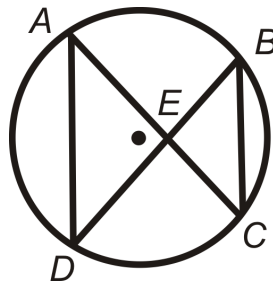

This makes the corresponding sides in each triangle proportional and leads to a relationship between the segments of the chords, as stated in the Intersecting Chords Theorem.

Intersecting Chords Theorem: If two chords intersect inside a circle so that one is divided into segments of length a and b and the other into segments of length c and d then $ab = cd$.

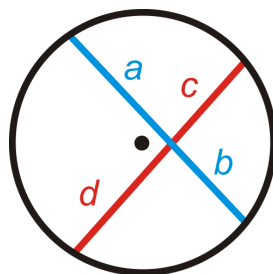

Example AFind x in each diagram below.

a)

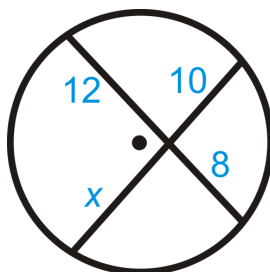

b)

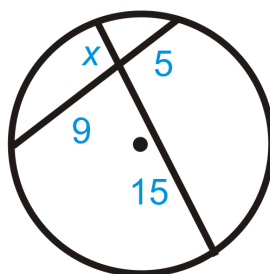

Use the formula from the Intersecting Chords Theorem.

a)

$$\begin{aligned} 12 \cdot 8 &= 10 \cdot x \\ 96 &= 10x \\ 9.6 &= x \end{aligned}$$

b)

$$\begin{aligned} x \cdot 15 &= 5 \cdot 9 \\ 15x &= 45 \\ x &= 3 \end{aligned}$$

Example BSolve for x .

a)

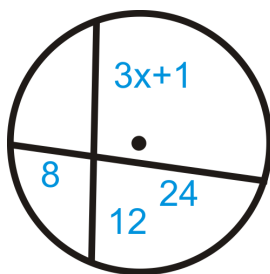

b)

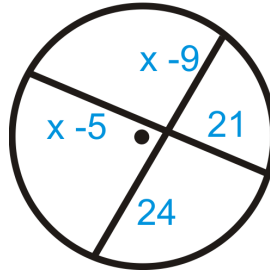

Use the Intersecting Chords Theorem.

a)

$$\begin{aligned} 8 \cdot 24 &= (3x + 1) \cdot 12 \\ 192 &= 36x + 12 \\ 180 &= 36x \\ 5 &= x \end{aligned}$$

b)

$$\begin{aligned} (x - 5)21 &= (x - 9)24 \\ 21x - 105 &= 24x - 216 \\ 111 &= 3x \\ 37 &= x \end{aligned}$$

Example C

Ishmael found a broken piece of a CD in his car. He places a ruler across two points on the rim, and the length of the chord is 9.5 cm. The distance from the midpoint of this chord to the nearest point on the rim is 1.75 cm. Find the diameter of the CD.

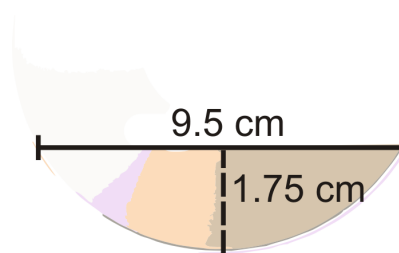

Think of this as two chords intersecting each other. If we were to extend the 1.75 cm segment, it would be a diameter. So, if we find x in the diagram below and add it to 1.75 cm, we would find the diameter.

$$\begin{aligned} 4.25 \cdot 4.25 &= 1.75 \cdot x \\ 18.0625 &= 1.75x \\ x &\approx 10.3 \text{ cm, making the diameter } 10.3 + 1.75 \approx 12 \text{ cm, which is the} \\ &\text{actual diameter of a CD.} \end{aligned}$$

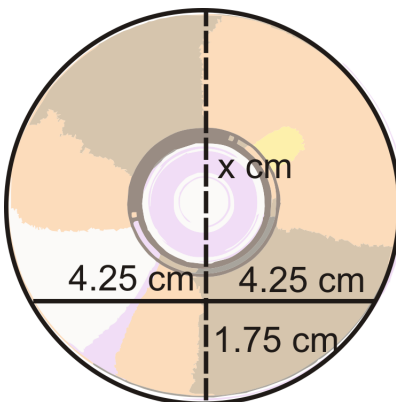

MEDIA
Click image to the left for more content.

Segments from Chords CK-12

Guided Practice

Find x in each diagram below. Simplify any radicals.

1.

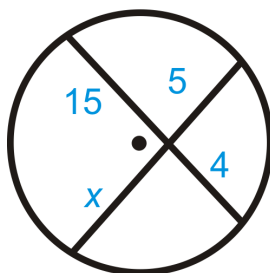

2.

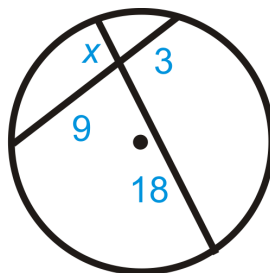

3.

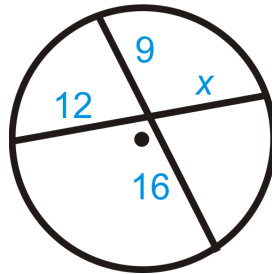
**Answers**

For all problems, use the Intersecting Chords Theorem.

1.

$$15 \cdot 4 = 5 \cdot x$$

$$60 = 5x$$

$$x = 12$$

2.

$$18 \cdot x = 9 \cdot 3$$

$$18x = 27$$

$$x = 1.5$$

3.

$$12 \cdot x = 9 \cdot 16$$

$$12x = 144$$

$$x = 12$$

Practice

Fill in the blanks for each problem below and then solve for the missing segment.

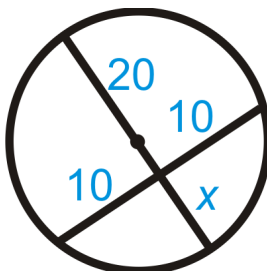

1.

$$20x = \underline{\quad}$$

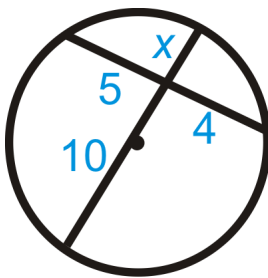

2.

$$__\cdot 4 = __\cdot x$$

Find x in each diagram below. Simplify any radicals.

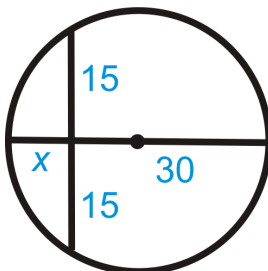

3.

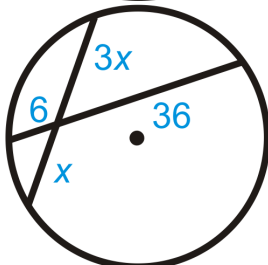

4.

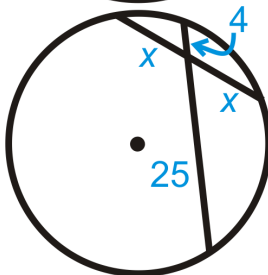

5.

Find the value of x .

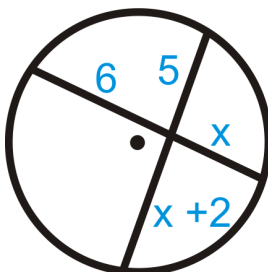

6.

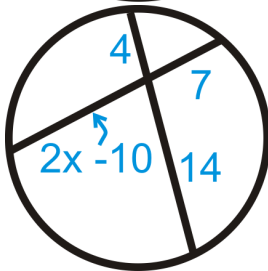

7.

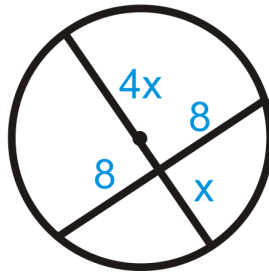

8.

9. Suzie found a piece of a broken plate. She places a ruler across two points on the rim, and the length of the chord is 6 inches. The distance from the midpoint of this chord to the nearest point on the rim is 1 inch. Find the diameter of the plate.
10. Fill in the blanks of the proof of the Intersecting Chords Theorem.

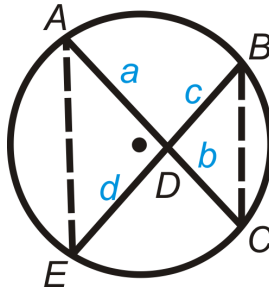

Given: Intersecting chords \overline{AC} and \overline{BE} .

Prove: $ab = cd$

TABLE 9.5:

<i>Statement</i>	<i>Reason</i>
1. Intersecting chords \overline{AC} and \overline{BE} with segments a , b , c , and d .	1.
2.	2. Congruent Inscribed Angles Theorem
3. $\triangle ADE \sim \triangle BDC$	3.
4.	4. Corresponding parts of similar triangles are proportional
5. $ab = cd$	5.

9.10 Segments from Secants

Here you'll learn the relationship between the segments that are created when two secants intersect outside a circle. You'll then use this relationship to solve for unknown circle values.

What if you were given a circle with two secants that intersect outside the circle? How could you use the length of some of the segments formed by their intersection to determine the lengths of the unknown segments? After completing this Concept, you'll be able to use the Two Secants Segments Theorem to solve problems like this one.

Watch This



MEDIA

Click image to the left for more content.

[Segments from Secants CK-12](#)

Guidance

When two secants intersect outside a circle, the circle divides the secants into segments that are proportional with each other.

Two Secants Segments Theorem: If two secants are drawn from a common point outside a circle and the segments are labeled as below, then $a(a + b) = c(c + d)$.

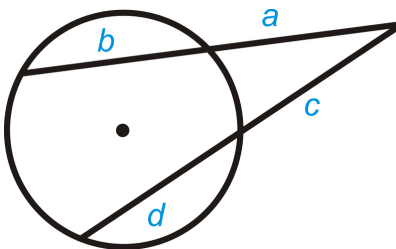

Example A

Find the value of x .

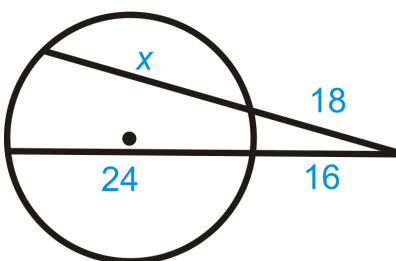

Use the Two Secants Segments Theorem to set up an equation.

$$\begin{aligned} 18 \cdot (18 + x) &= 16 \cdot (16 + 24) \\ 324 + 18x &= 256 + 384 \\ 18x &= 316 \\ x &= 17\frac{5}{9} \end{aligned}$$

Example B

Find the value of x .

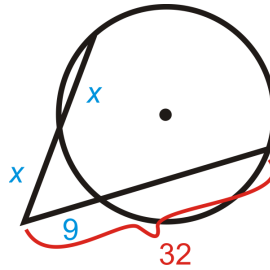

Use the Two Secants Segments Theorem to set up an equation.

$$\begin{aligned} x \cdot (x + x) &= 9 \cdot 32 \\ 2x^2 &= 288 \\ x^2 &= 144 \\ x &= 12, x \neq -12 \text{ (length is not negative)} \end{aligned}$$

Example C

True or False: Two secants will always intersect outside of a circle.

This is false. If the two secants are parallel, they will never intersect. It's also possible for two secants to intersect inside a circle.



MEDIA

Click image to the left for more content.

[Segments from Secants CK-12](#)

Guided Practice

Find x in each diagram below. Simplify any radicals.

1.

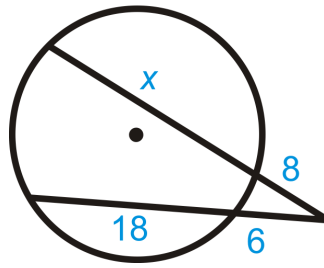

2.

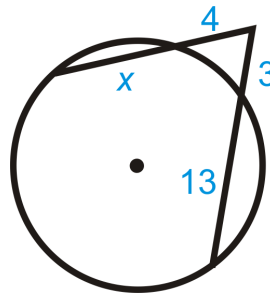

3.

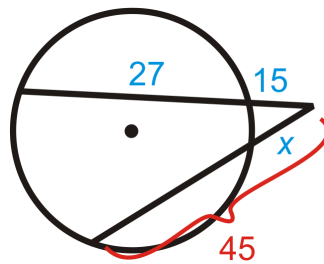
**Answers:**

Use the Two Secants Segments Theorem.

1.

$$8(8+x) = 6(6+18)$$

$$64 + 8x = 144$$

$$8x = 80$$

$$x = 10$$

2.

$$4(4+x) = 3(3+13)$$

$$16 + 4x = 48$$

$$4x = 32$$

$$x = 8$$

3.

$$15(15 + 27) = x \cdot 45$$

$$630 = 45x$$

$$x = 14$$

Practice

Fill in the blanks for each problem below. Then, solve for the missing segment.

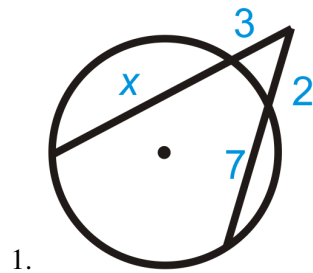

$$3(\underline{\quad} + \underline{\quad}) = 2(2 + 7)$$

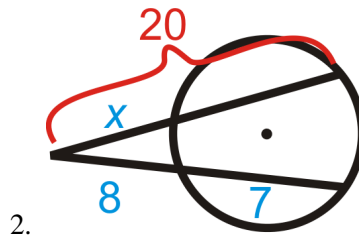

$$x \cdot \underline{\quad} = 8(\underline{\quad} + \underline{\quad})$$

Find x in each diagram below. Simplify any radicals.

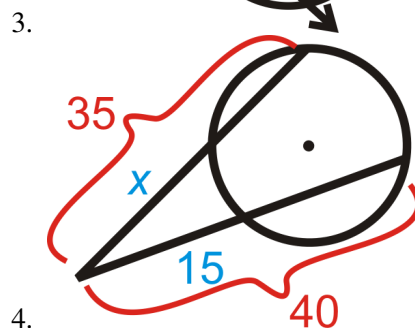
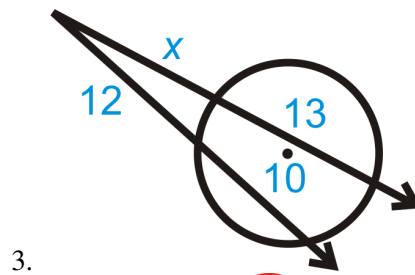

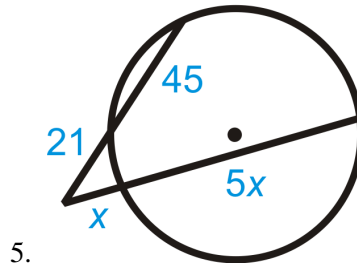

5.

6. Fill in the blanks of the proof of the Two Secants Segments Theorem.

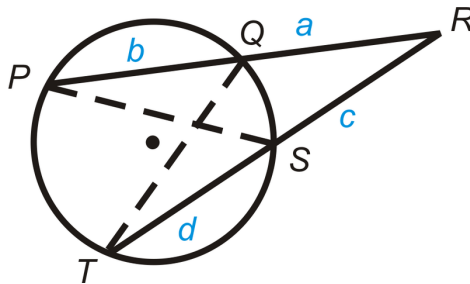

Given: Secants \overline{PR} and \overline{RT}

Prove: $a(a + b) = c(c + d)$

TABLE 9.6:

Statement

1. Secants \overline{PR} and \overline{RT} with segments a , b , c , and d .
2. $\angle R \cong \angle R$
3. $\angle QPS \cong \angle STQ$
4. $\triangle RPS \sim \triangle RTQ$
5. $\frac{a}{c+d} = \frac{c}{a+b}$
6. $a(a + b) = c(c + d)$

Reason

1. Given
2. Reflexive PoC
3. Congruent Inscribed Angles Theorem
4. AA Similarity Postulate
5. Corresponding parts of similar triangles are proportional
6. Cross multiplication

Solve for the unknown variable.

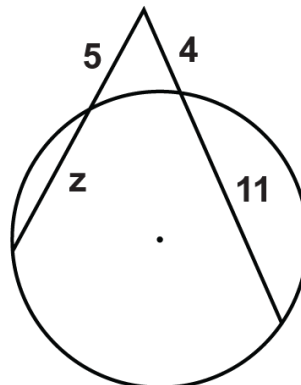

7.

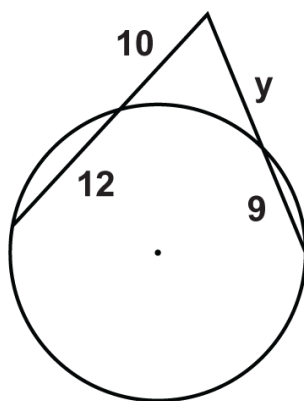

8.

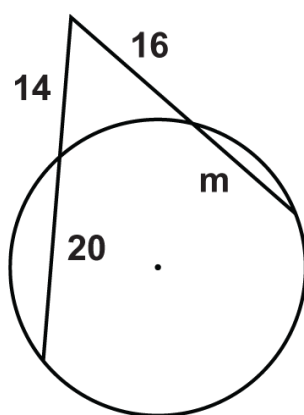

9.

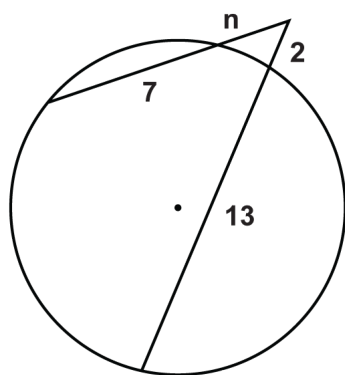

10.

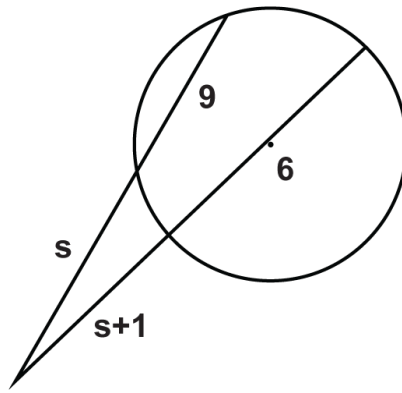

11.

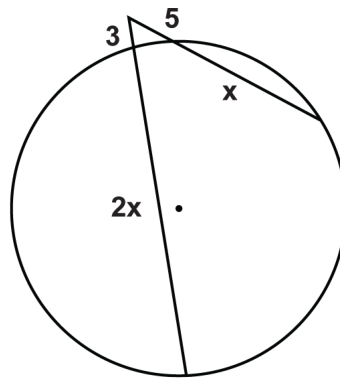

12.

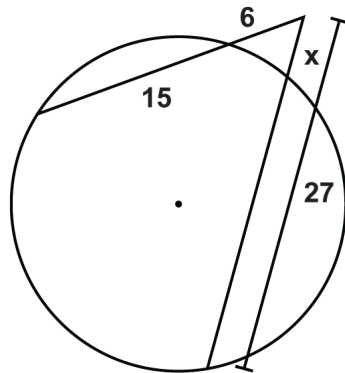

13.

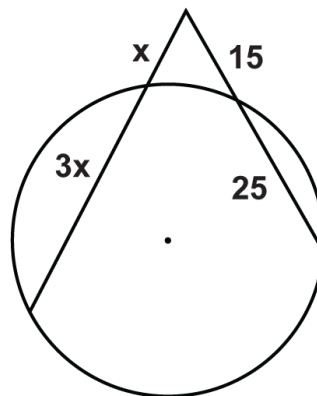

14.

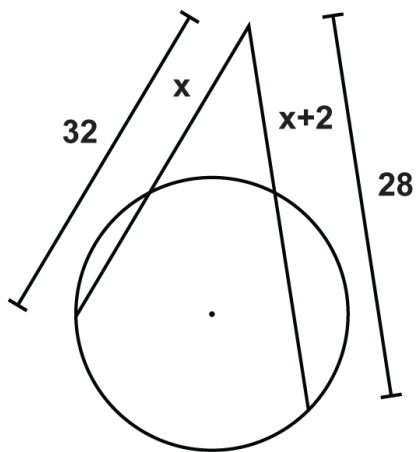

15.

9.11 Segments from Secants and Tangents

Here you'll learn the relationship that exists between the segments that are created when a secant and tangent intersect on a circle. You'll then use this relationship to solve for unknown circle values.

What if you were given a circle with a tangent and a secant that intersect outside the circle? How could you use the length of some of the segments formed by their intersection to determine the lengths of the unknown segments? After completing this Concept, you'll be able to use the Tangent Secant Segment Theorem to solve problems like this one.

Watch This



MEDIA

Click image to the left for more content.

[Segments from Secants and Tangents CK-12](#)

Guidance

If a tangent and secant meet at a common point outside a circle, the segments created have a similar relationship to that of two secant rays.

Tangent Secant Segment Theorem: If a tangent and a secant are drawn from a common point outside the circle (and the segments are labeled like the picture below), then $a^2 = b(b + c)$.

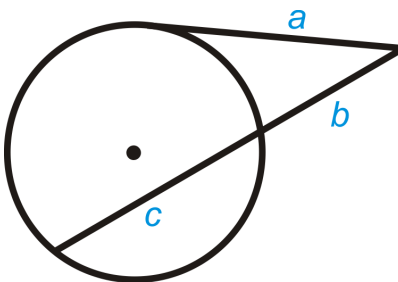

Example A

Find the length of the missing segment.

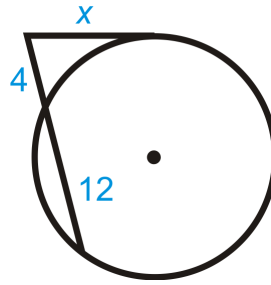

Use the Tangent Secant Segment Theorem.

$$x^2 = 4(4 + 12)$$

$$x^2 = 4 \cdot 16 = 64$$

$$x = 8$$

Example B

Fill in the blank and then solve for the missing segment.

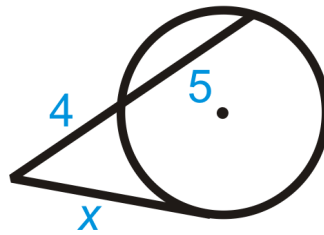

$$\underline{\quad} = \underline{\quad}(4 + 5)$$

$$x^2 = 4(4 + 5)$$

$$x^2 = 36$$

$$x = 6$$

Example C

Find the value of the missing segment.

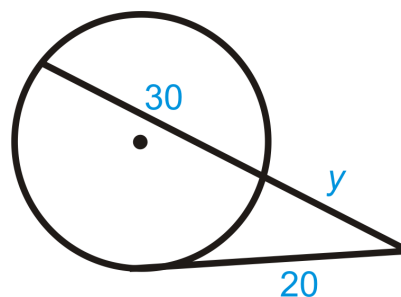

Use the Tangent Secant Segment Theorem.

$$\begin{aligned}
 20^2 &= y(y + 30) \\
 400 &= y^2 + 30y \\
 0 &= y^2 + 30y - 400 \\
 0 &= (y + 40)(y - 10) \\
 y &= \cancel{40}, 10
 \end{aligned}$$



MEDIA

Click image to the left for more content.

Segments from Secants and Tangents CK-12

Guided Practice

Find x in each diagram below. Simplify any radicals.

1.

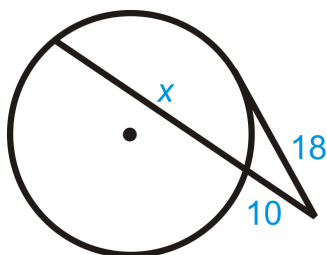

2.

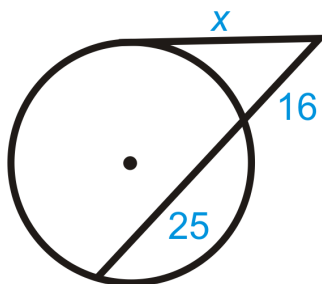

3.

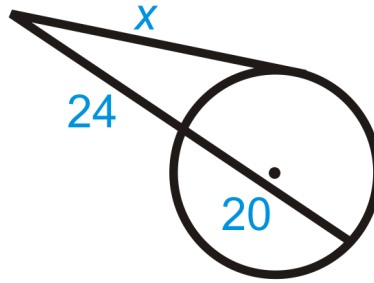
**Answers:**

Use the Tangent Secant Segment Theorem.

1.

$$18^2 = 10(10 + x)$$

$$324 = 100 + 10x$$

$$224 = 10x$$

$$x = 22.4$$

2.

$$x^2 = 16(16 + 25)$$

$$x^2 = 656$$

$$x = 4\sqrt{41}$$

3.

$$x^2 = 24(24 + 20)$$

$$x^2 = 1056$$

$$x = 4\sqrt{66}$$

Practice

Fill in the blanks for each problem below and then solve for the missing segment.

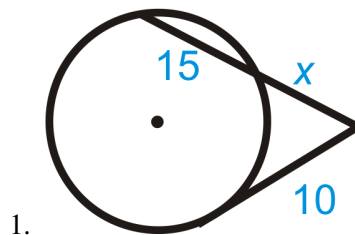

$$10^2 = x(\underline{\quad} + \underline{\quad})$$

Find x in each diagram below. Simplify any radicals.

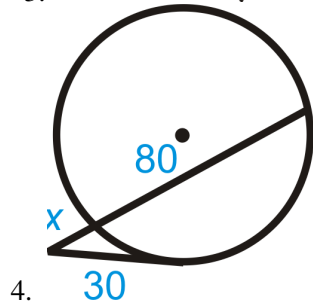
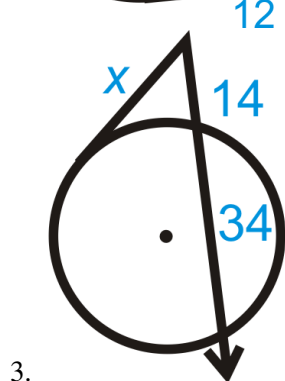
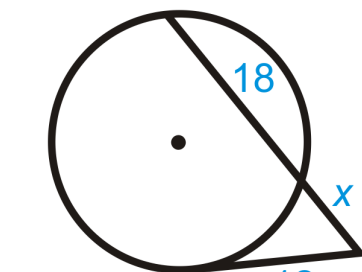

5. Describe and correct the error in finding y.

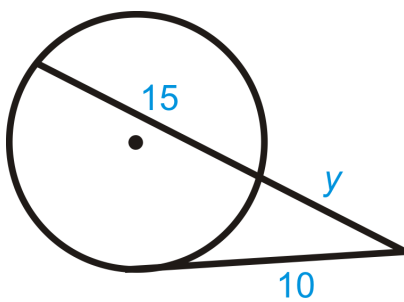

$$\begin{aligned}
 10 \cdot 10 &= y \cdot 15y \\
 100 &= 15y^2 \\
 \frac{20}{3} &= y^2 \\
 \frac{2\sqrt{15}}{3} &= y \quad \leftarrow y \text{ is not correct}
 \end{aligned}$$

Solve for the unknown variable.

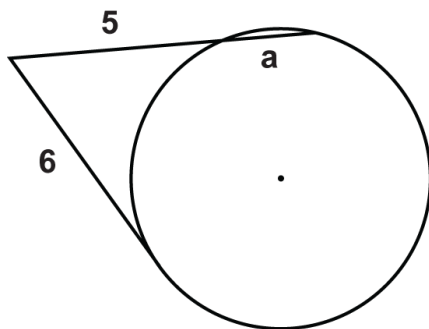

6.

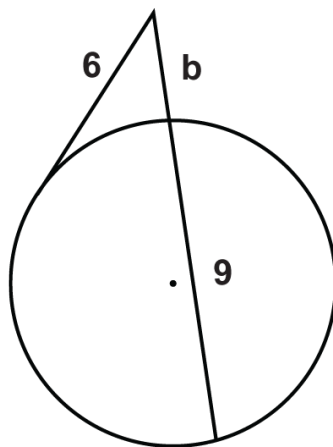

7.

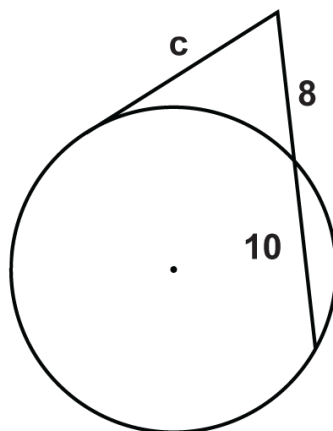

8.

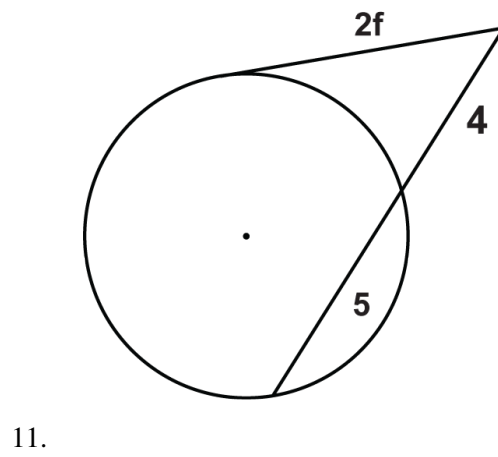
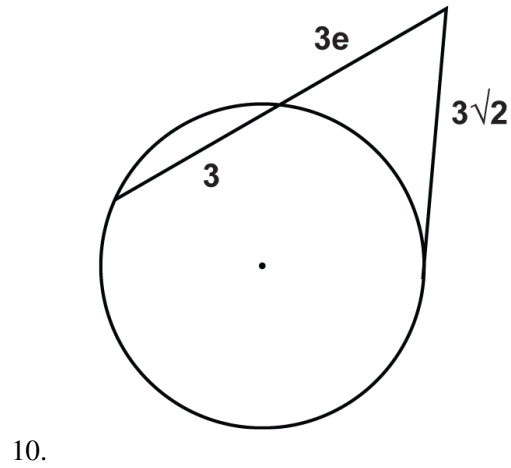
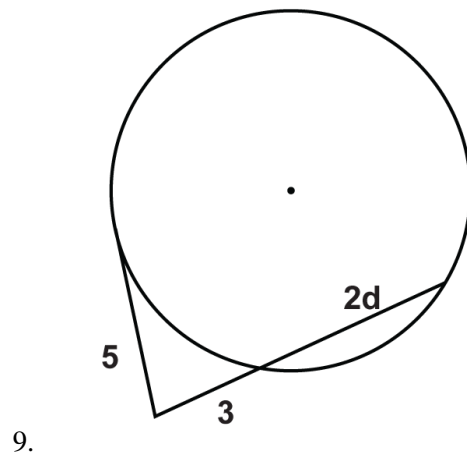

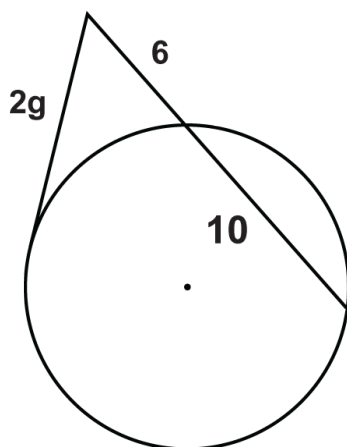

12.

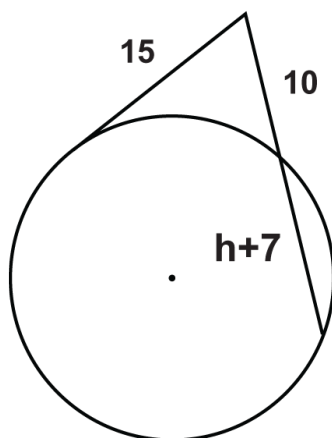

13.

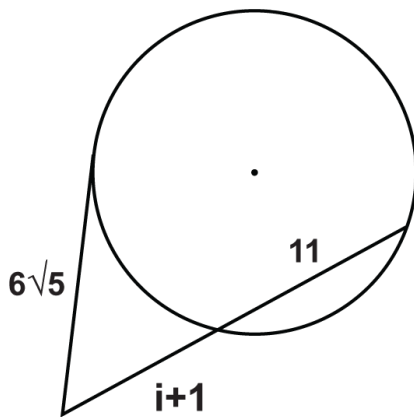

14.

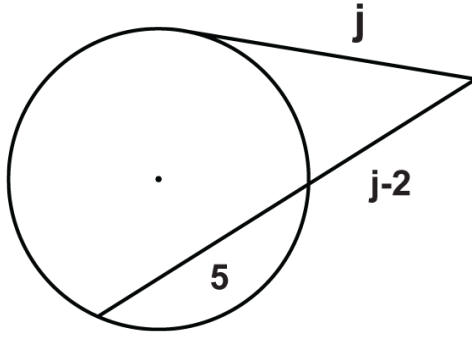

15.

9.12 Circles in the Coordinate Plane

Here you'll learn how to find the standard equation for circles given their radius and center. You'll also graph circles in the coordinate plane.

What if you were given the length of the radius of a circle and the coordinates of its center? How could you write the equation of the circle in the coordinate plane? After completing this Concept, you'll be able to write the standard equation of a circle.

Watch This



MEDIA

Click image to the left for more content.

GraphingCirclesCK-12

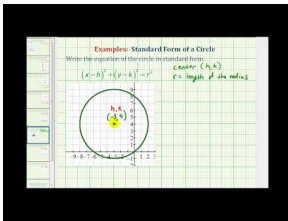

MEDIA

Click image to the left for more content.

James Sousa: Write the Standard Form of a Circle

Guidance

Recall that a circle is the set of all points in a plane that are the same distance from the center. This definition can be used to find an equation of a circle in the coordinate plane.

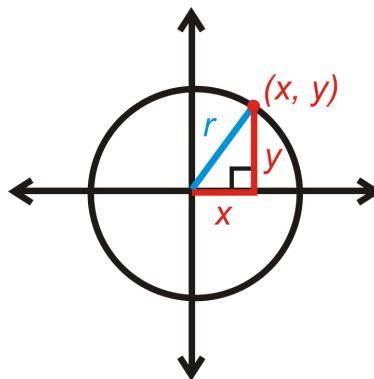

Let's start with the circle centered at $(0, 0)$. If (x, y) is a point on the circle, then the distance from the center to this point would be the radius, r . x is the horizontal distance and y is the vertical distance. This forms a right triangle. From the Pythagorean Theorem, the equation of a circle *centered at the origin* is $x^2 + y^2 = r^2$.

The center does not always have to be on $(0, 0)$. If it is not, then we label the center (h, k) . We would then use the Distance Formula to find the length of the radius.

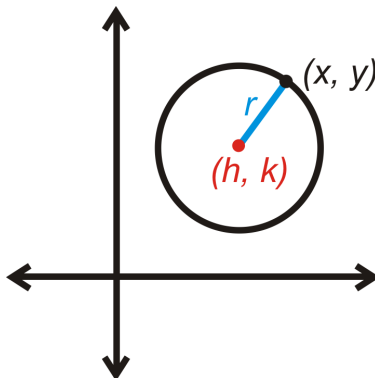

$$r = \sqrt{(x - h)^2 + (y - k)^2}$$

If you square both sides of this equation, then you would have the standard equation of a circle. **The standard equation of a circle with center (h, k) and radius r is $r^2 = (x - h)^2 + (y - k)^2$.**

Example A

Graph $x^2 + y^2 = 9$.

The center is $(0, 0)$. Its radius is the square root of 9, or 3. Plot the center, plot the points that are 3 units to the right, left, up, and down from the center and then connect these four points to form a circle.

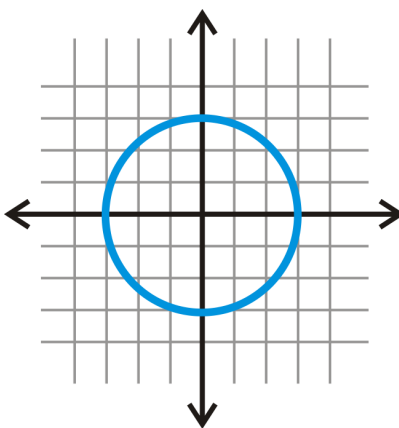

Example B

Find the equation of the circle below.

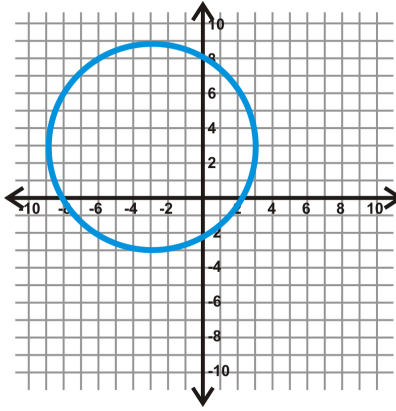

First locate the center. Draw in the horizontal and vertical diameters to see where they intersect.

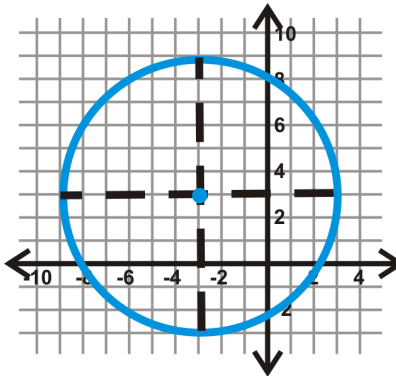

From this, we see that the center is $(-3, 3)$. If we count the units from the center to the circle on either of these diameters, we find $r = 6$. Plugging this into the equation of a circle, we get: $(x - (-3))^2 + (y - 3)^2 = 6^2$ or $(x + 3)^2 + (y - 3)^2 = 36$.

Example C

Determine if the following points are on $(x + 1)^2 + (y - 5)^2 = 50$.

a) $(8, -3)$

b) $(-2, -2)$

Plug in the points for x and y in $(x + 1)^2 + (y - 5)^2 = 50$.

a)

$$(8 + 1)^2 + (-3 - 5)^2 = 50$$

$$9^2 + (-8)^2 = 50$$

$$81 + 64 \neq 50$$

$(8, -3)$ is not on the circle

b)

$$(-2 + 1)^2 + (-2 - 5)^2 = 50$$

$$(-1)^2 + (-7)^2 = 50$$

$$1 + 49 = 50$$

$(-2, -2)$ is on the circle



MEDIA

Click image to the left for more content.

GraphingCirclesCK-12

Guided Practice

Find the center and radius of the following circles.

- $(x - 3)^2 + (y - 1)^2 = 25$
- $(x + 2)^2 + (y - 5)^2 = 49$

3. Find the equation of the circle with center $(4, -1)$ and which passes through $(-1, 2)$.

Answers:

- Rewrite the equation as $(x - 3)^2 + (y - 1)^2 = 5^2$. The center is $(3, 1)$ and $r = 5$.
- Rewrite the equation as $(x - (-2))^2 + (y - 5)^2 = 7^2$. The center is $(-2, 5)$ and $r = 7$.

Keep in mind that, due to the minus signs in the formula, the coordinates of the center have the *opposite signs* of what they may initially appear to be.

3. First plug in the center to the standard equation.

$$\begin{aligned}(x - 4)^2 + (y - (-1))^2 &= r^2 \\(x - 4)^2 + (y + 1)^2 &= r^2\end{aligned}$$

Now, plug in $(-1, 2)$ for x and y and solve for r .

$$\begin{aligned}(-1 - 4)^2 + (2 + 1)^2 &= r^2 \\(-5)^2 + (3)^2 &= r^2 \\25 + 9 &= r^2 \\34 &= r^2\end{aligned}$$

Substituting in 34 for r^2 , the equation is $(x - 4)^2 + (y + 1)^2 = 34$.

Practice

Find the center and radius of each circle. Then, graph each circle.

- $(x + 5)^2 + (y - 3)^2 = 16$
- $x^2 + (y + 8)^2 = 4$
- $(x - 7)^2 + (y - 10)^2 = 20$

4. $(x+2)^2 + y^2 = 8$

Find the equation of the circles below.

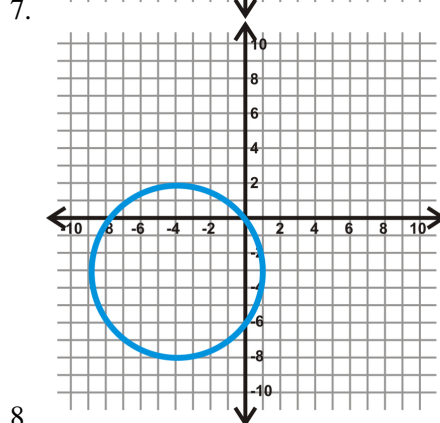
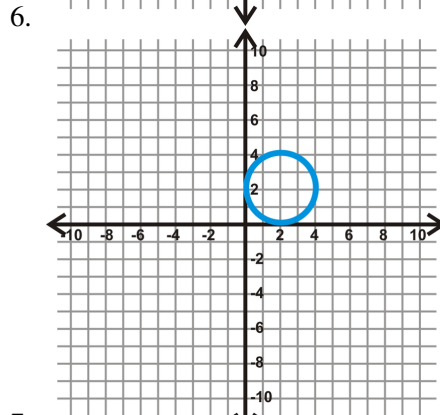
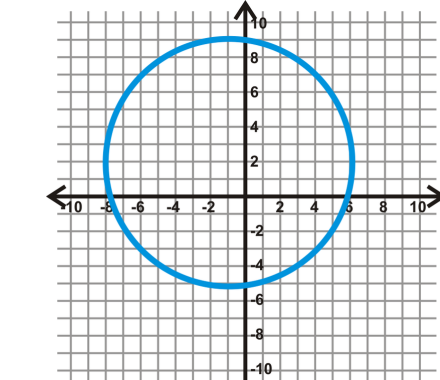
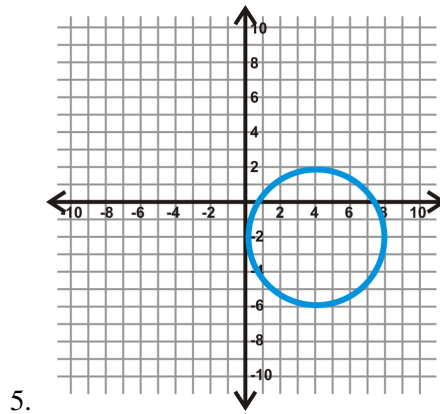

9. Is $(-7, 3)$ on $(x+1)^2 + (y-6)^2 = 45$?

10. Is $(9, -1)$ on $(x-2)^2 + (y-2)^2 = 60$?

11. Is $(-4, -3)$ on $(x+3)^2 + (y-3)^2 = 37$?
12. Is $(5, -3)$ on $(x+1)^2 + (y-6)^2 = 45$?

Find the equation of the circle with the given center and point on the circle.

13. center: $(2, 3)$, point: $(-4, -1)$
14. center: $(10, 0)$, point: $(5, 2)$
15. center: $(-3, 8)$, point: $(7, -2)$
16. center: $(6, -6)$, point: $(-9, 4)$

Summary

This chapter begins with vocabulary associated with the parts of circles. It then branches into theorems about tangent lines; properties of arcs and central angles; and theorems about chords and how to apply them. Inscribed angles and inscribed quadrilaterals and their properties are explored. Angles on, inside, and outside a circle are presented in detail and the subsequent relationships are used in problem solving. Relationships among chords, secants, and tangents are discovered and applied. The chapter ends with the connection between algebra and geometry as the equations of circles are discussed.

CHAPTER 10**Perimeter and Area****Chapter Outline**

- 10.1 AREA AND PERIMETER OF RECTANGLES**
 - 10.2 AREA OF A PARALLELOGRAM**
 - 10.3 AREA AND PERIMETER OF TRIANGLES**
 - 10.4 AREA OF COMPOSITE SHAPES**
 - 10.5 AREA AND PERIMETER OF TRAPEZOIDS**
 - 10.6 AREA AND PERIMETER OF RHOMBUSES AND KITES**
 - 10.7 AREA AND PERIMETER OF SIMILAR POLYGONS**
 - 10.8 CIRCUMFERENCE**
 - 10.9 ARC LENGTH**
 - 10.10 AREA OF A CIRCLE**
 - 10.11 AREA OF SECTORS AND SEGMENTS**
-

Introduction

Now that we have explored triangles, quadrilaterals, polygons, and circles, we are going to learn how to find the perimeter and area of each.

10.1 Area and Perimeter of Rectangles

Here you'll learn how to find the area and perimeter of a rectangle given its base and height.

What if you were given a rectangle and the size of its base and height? How could you find the total distance around the rectangle and the amount of space it takes up? After completing this Concept, you'll be able to use the formulas for the perimeter and area of a rectangle to solve problems like this.

Watch This



MEDIA

Click image to the left for more content.

[Area and Perimeter of Rectangles CK-12](#)

Guidance

To find the **area of a rectangle**, calculate $A = bh$, where b is the base (width) and h is the height (length). The **perimeter of a rectangle** will always be $P = 2b + 2h$.

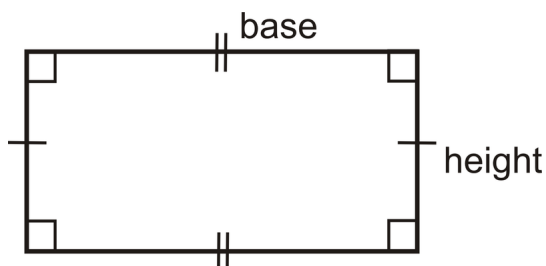

If a rectangle is a square, with sides of length s , then perimeter is $P_{square} = 2s + 2s = 4s$ and area is $A_{square} = s \cdot s = s^2$.

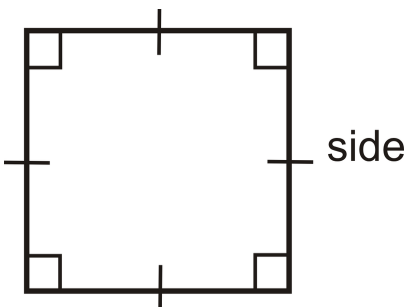

Example A

Find the area and perimeter of a rectangle with sides 4 cm by 9 cm.



The perimeter is $4 + 9 + 4 + 9 = 26$ cm. The area is $A = 9 \cdot 4 = 36$ cm^2 .

Example B

Find the area and perimeter of a square with side 5 in.

The perimeter is $4(5) = 20$ in and the area is $5^2 = 25$ in^2 .

Example C

Find the area and perimeter of a rectangle with sides 13 m and 12 m.

The perimeter is $2(13) + 2(12) = 50$ m. The area is $13(12) = 156$ m^2 .



MEDIA

Click image to the left for more content.

[Area and Perimeter of Rectangles CK-12](#)

Guided Practice

1. The area of a square is 75 in^2 . Find the perimeter.
2. Draw two different rectangles with an area of 36 cm^2 .
3. Find the area and perimeter of a rectangle with sides 7 in and 10 in.

Answers:

1. To find the perimeter, we need to find the length of the sides.

$$A = s^2 = 75 \text{ in}^2$$

$$s = \sqrt{75} = 5\sqrt{3} \text{ in}$$

From this, $P = 4(5\sqrt{3}) = 20\sqrt{3}$ in.

2. Think of all the different factors of 36. These can all be dimensions of the different rectangles.

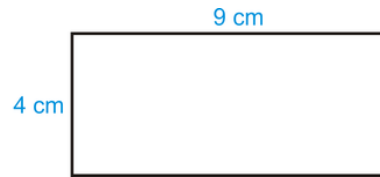

Other possibilities could be 6×6 , 2×18 , and 1×36 .

3. Area is $7(10) = 70 \text{ in}^2$. Perimeter is $2(7) + 2(10) = 34 \text{ in}$.

Practice

1. Find the area and perimeter of a square with sides of length 12 in.
2. Find the area and perimeter of a rectangle with height of 9 cm and base of 16 cm.
3. Find the area and perimeter of a rectangle if the height is 8 and the base is 14.
4. Find the area and perimeter of a square if the sides are 18 ft.
5. If the area of a square is 81 ft^2 , find the perimeter.
6. If the perimeter of a square is 24 in, find the area.
7. The perimeter of a rectangle is 32. Find two different dimensions that the rectangle could be.
8. Draw two different rectangles that haven an area of 90 mm^2 .
9. True or false: For a rectangle, the bigger the perimeter, the bigger the area.
10. Find the perimeter and area of a rectangle with sides 17 in and 21 in.

10.2 Area of a Parallelogram

Here you'll learn how to find the area of a parallelogram given its base and height.

What if you were given a parallelogram and the size of its base and height? How could you find the amount of space the parallelogram takes up? After completing this Concept, you'll be able to use the formula for the area of a parallelogram to solve problems like this one.

Watch This



MEDIA

Click image to the left for more content.

CK-12

Guidance

A **parallelogram** is a quadrilateral whose opposite sides are parallel.

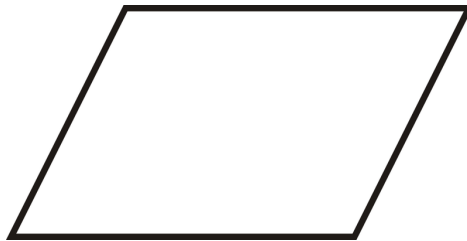

To find the area of a parallelogram, make it into a rectangle.

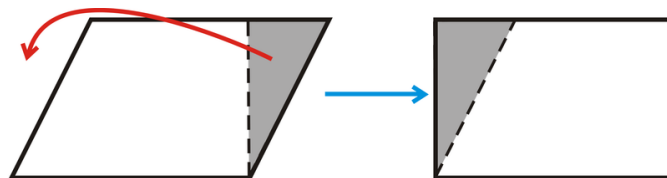

From this, we see that the area of a parallelogram is the same as the area of a rectangle. The area of a parallelogram is $A = bh$. The height of a parallelogram is always perpendicular to the base. *This means that the sides are not the height.*

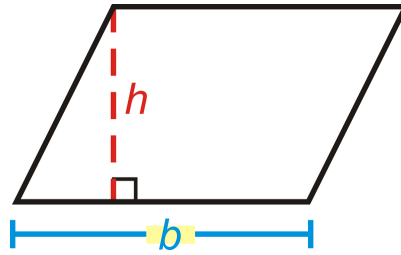
**Example A**

Find the area of the parallelogram.

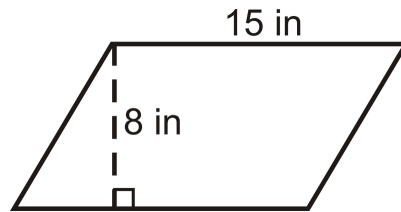

$$A = 15 \cdot 8 = 120 \text{ in}^2$$

Example B

If the area of a parallelogram is 56 units^2 and the base is 4 units, what is the height?

Solve for the height in $A = bh$.

$$56 \text{ units} = 4h$$

$$14 \text{ units} = h$$

Example C

If the height of a parallelogram is 12 m and the area is 60 m^2 , how wide is the base?

Solve for the base in $A = bh$.

$$60 \text{ units} = 12b$$

$$5 \text{ units} = b$$



MEDIA

Click image to the left for more content.

Guided Practice

Find the area of the following shapes.

1.

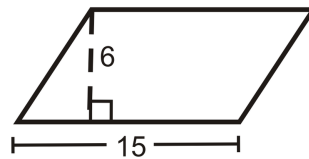

2.

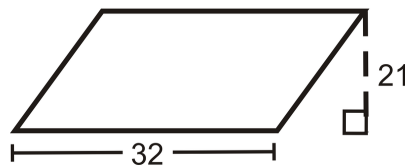

3. A parallelogram with a base of 10 m and a height of 12 m.

Answers:

1. Area is $15(6) = 90 \text{ un}^2$.
2. Area is $32(12) = 672 \text{ un}^2$.
3. Area is $10(12) = 120 \text{ m}^2$.

Practice

1. Find the area of a parallelogram with height of 20 m and base of 18 m.
2. Find the area of a parallelogram with height of 12 m and base of 15 m.
3. Find the area of a parallelogram with height of 40 m and base of 33 m.
4. Find the area of a parallelogram with height of 32 m and base of 21 m.
5. Find the area of a parallelogram with height of 25 m and base of 10 m.

Find the area of the parallelogram.

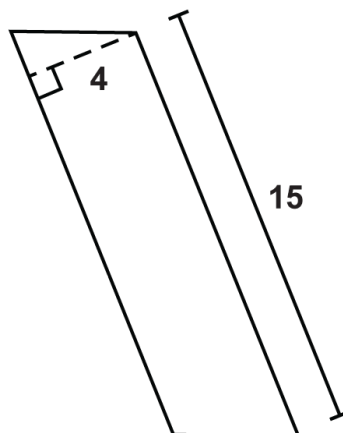

6.

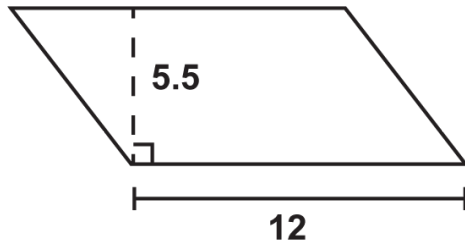

7.

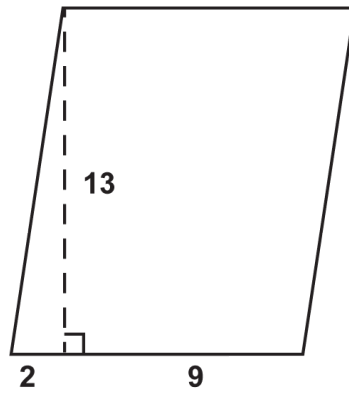

8.

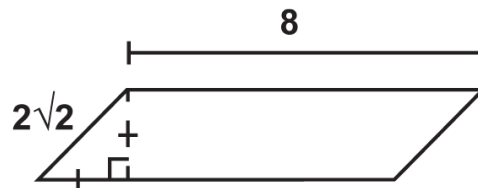

9.

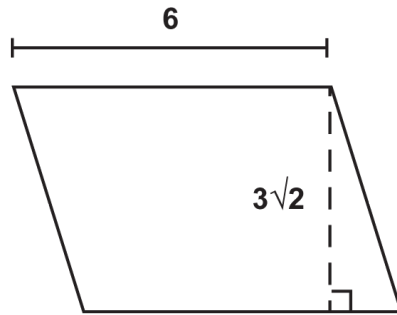

10.

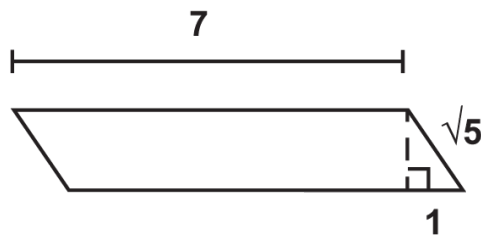

11.

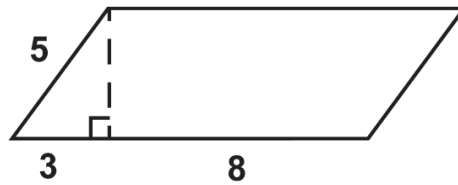

12.

13. If the area of a parallelogram is 42 units^2 and the base is 6 units, what is the height?
14. If the area of a parallelogram is 48 units^2 and the height is 6 units, what is the base?
15. If the base of a parallelogram is 9 units and the area is 108 units^2 , what is the height?
16. If the height of a parallelogram is 11 units and the area is 27.5 units^2 , what is the base?

10.3 Area and Perimeter of Triangles

Here you'll learn how to find the area and perimeter of a triangle given its base and height.

What if you were given a triangle and the size of its base and height? How could you find the total distance around the triangle and the amount of space it takes up? After completing this Concept, you'll be able to use the formulas for the perimeter and area of a triangle to solve problems like this.

Watch This



MEDIA

Click image to the left for more content.

[Area and Perimeter of Triangles CK-12](#)

Guidance

The formula for the area of a triangle is half the area of a parallelogram.

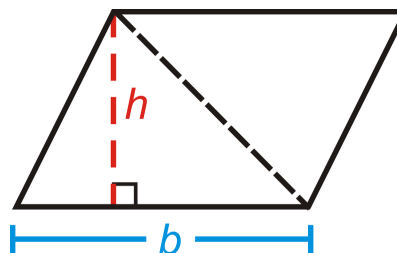

Area of a Triangle: $A = \frac{1}{2}bh$ or $A = \frac{bh}{2}$.

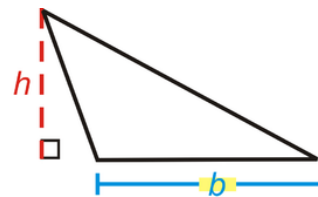
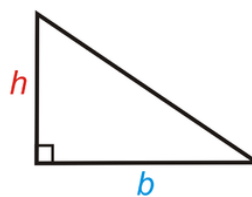
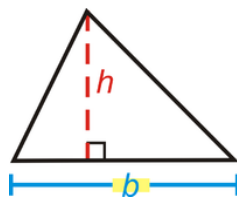

Example A

Find the area of the triangle.

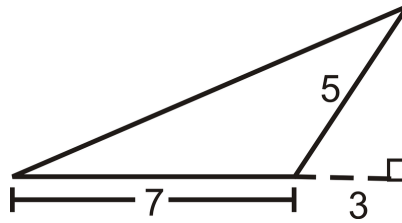

To find the area, we need to find the height of the triangle. We are given two sides of the small right triangle, where the hypotenuse is also the short side of the obtuse triangle.

$$3^2 + h^2 = 5^2$$

$$9 + h^2 = 25$$

$$h^2 = 16$$

$$h = 4$$

$$A = \frac{1}{2}(4)(7) = 14 \text{ units}^2$$

Example B

Find the perimeter of the triangle in Example A.

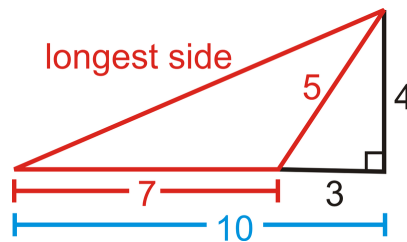

To find the perimeter, we need to find the longest side of the obtuse triangle. If we used the black lines in the picture, we would see that the longest side is also the hypotenuse of the right triangle with legs 4 and 10.

$$4^2 + 10^2 = c^2$$

$$16 + 100 = c^2$$

$$c = \sqrt{116} \approx 10.77$$

The perimeter is $7 + 5 + 10.77 \approx 22.77$ units

Example C

Find the area of a triangle with base of length 28 cm and height of 15 cm.

The area is $\frac{1}{2}(28)(15) = 210 \text{ cm}^2$.



MEDIA

 Click image to the left for more content.

Area and Perimeter of Triangles CK-12

Guided Practice

Use the triangle to answer the following questions.

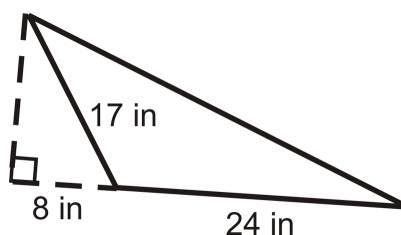

1. Find the height of the triangle.
2. Find the perimeter.
3. Find the area.

Answers:

1. Use the Pythagorean Theorem to find the height.

$$\begin{aligned} 8^2 + h^2 &= 17^2 \\ h^2 &= 225 \\ h &= 15 \text{ in} \end{aligned}$$

2. We need to find the hypotenuse. Use the Pythagorean Theorem again.

$$\begin{aligned} (8 + 24)^2 + 15^2 &= h^2 \\ h^2 &= 1249 \\ h &\approx 35.3 \text{ in} \end{aligned}$$

The perimeter is $24 + 35.3 + 17 \approx 76.3 \text{ in}$.

3. The area is $\frac{1}{2}(24)(15) = 180 \text{ in}^2$.

Practice

Use the triangle to answer the following questions.

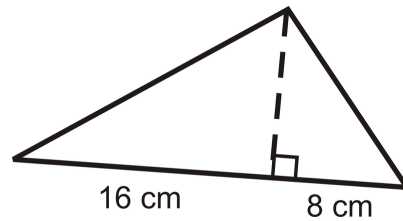

1. Find the height of the triangle by using the geometric mean.
2. Find the perimeter.
3. Find the area.

Find the area of the following shape.

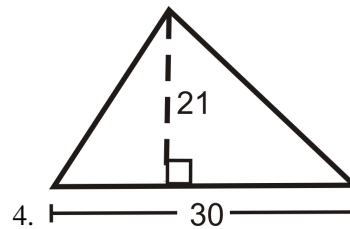

4. What is the height of a triangle with area 144 m^2 and a base of 24 m?

In questions 6-11 we are going to derive a formula for the area of an equilateral triangle.

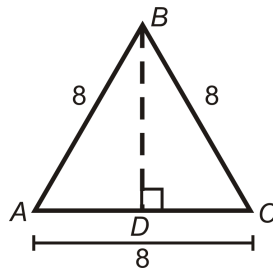

6. What kind of triangle is $\triangle ABD$? Find AD and BD .
7. Find the area of $\triangle ABC$.
8. If each side is x , what is AD and BD ?
9. If each side is x , find the area of $\triangle ABC$.
10. Using your formula from #9, find the area of an equilateral triangle with 12 inch sides.
11. Using your formula from #9, find the area of an equilateral triangle with 5 inch sides.

10.4 Area of Composite Shapes

Here you'll learn how to find the area of a figure that can be broken down into shapes you've already learned.

What if you drew a basic house with a triangle on top of a square? How could you find the area of this composite shape? After completing this Concept, you'll be able to calculate the area of irregular shapes that are made up of two or more shapes you already know.

Watch This



MEDIA

Click image to the left for more content.

[Area of Composite Shapes CK-12](#)

Guidance

Perimeter is the distance around a shape. The perimeter of any figure must have a unit of measurement attached to it. If no specific units are given (feet, inches, centimeters, etc), write “units.”

Area is the amount of space inside a figure. If two figures are congruent, they have the same area (**Congruent Areas Postulate**).

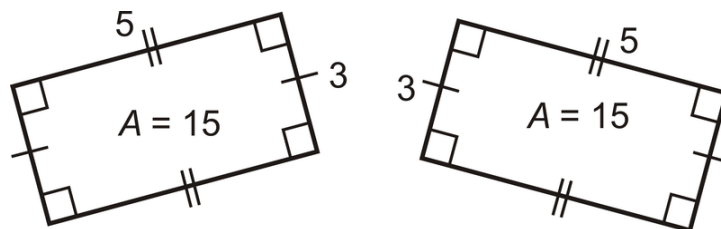

A **composite shape** is a shape made up of other shapes. To find the area of such a shape, simply find the area of each part and add them up.

Area Addition Postulate: If a figure is composed of two or more parts that do not overlap each other, then the area of the figure is the sum of the areas of the parts.

Example A

Find the area of the figure below.

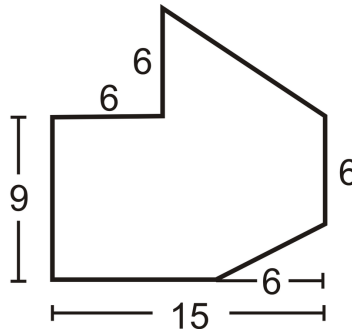

Divide the figure into a triangle and a rectangle with a small rectangle cut out of the lower right-hand corner.

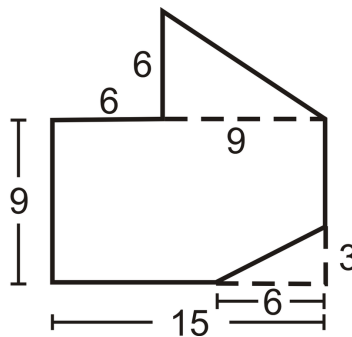

$$A = A_{\text{top triangle}} + A_{\text{rectangle}} - A_{\text{small triangle}}$$

$$A = \left(\frac{1}{2} \cdot 6 \cdot 9 \right) + (9 \cdot 15) - \left(\frac{1}{2} \cdot 3 \cdot 6 \right)$$

$$A = 27 + 135 - 9$$

$$A = 153 \text{ units}^2$$

Example B

Divide the shape into two rectangles and one triangle. Find the area of the two rectangles and triangle:

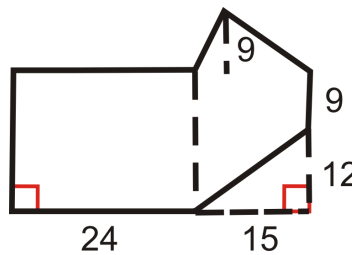

$$\text{Rectangle \#1: Area} = 24(9 + 12) = 504 \text{ units}^2$$

$$\text{Rectangle \#2: Area} = 15(9 + 12) = 315 \text{ units}^2$$

$$\text{Triangle: Area} = \frac{15(9)}{2} = 67.5 \text{ units}^2$$

Example C

Find the area of the entire shape from Example B (you will need to subtract the area of the small triangle in the lower right-hand corner).

$$\text{Total Area} = 504 + 315 + 67.5 - \frac{15(12)}{2} = 796.5 \text{ units}^2$$

**MEDIA**

Click image to the left for more content.

[Area of Composite Shapes CK-12](#)

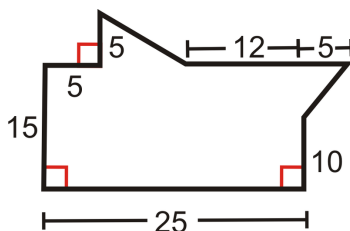
Guided Practice

1. Divide the shape into two triangles and one rectangle.
2. Find the area of the two triangles and rectangle.
3. Find the area of the entire shape.

Answers

1. One triangle on the top and one on the right. Rectangle is the rest.
2. Area of triangle on top is $\frac{8(5)}{2} = 20 \text{ units}^2$. Area of triangle on right is $\frac{5(5)}{2} = 12.5 \text{ units}^2$. Area of rectangle is 375 units^2 .
3. Total area is 407.5 units^2 .

Practice

Use the picture below for questions 1-4. Both figures are squares.

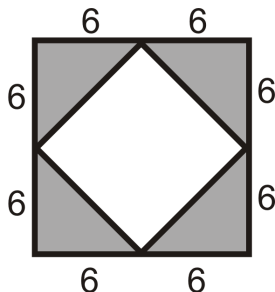

1. Find the area of the outer square.

2. Find the area of one grey triangle.
3. Find the area of all four grey triangles.
4. Find the area of the inner square.

Find the areas of the figures below. You may assume all sides are perpendicular.

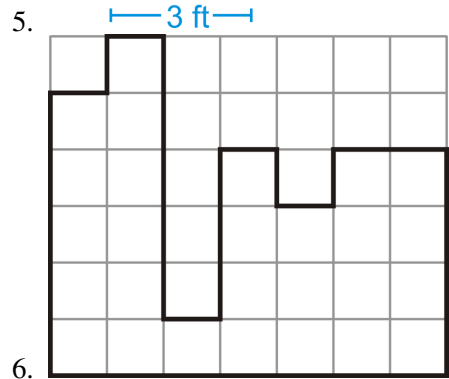
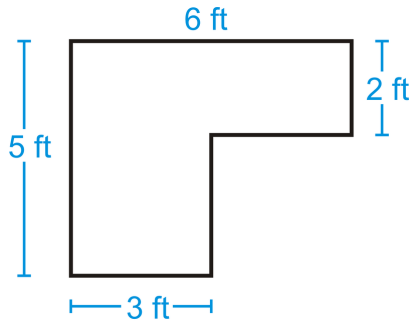

Find the areas of the composite figures.

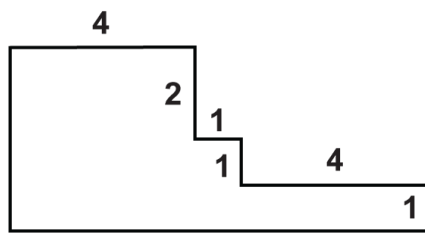

7.

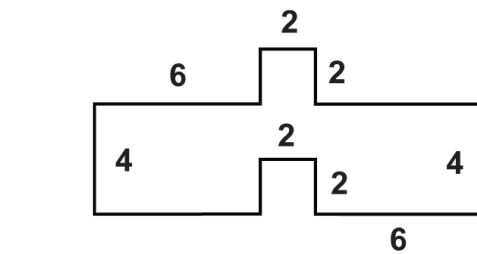
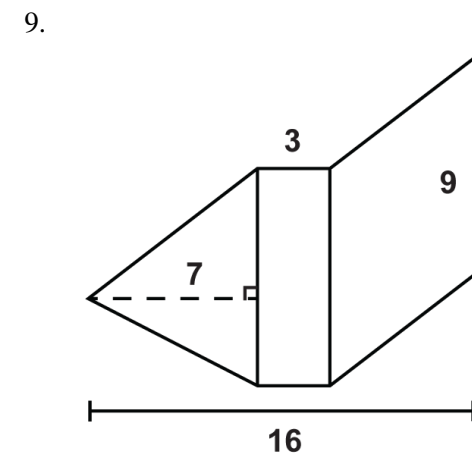
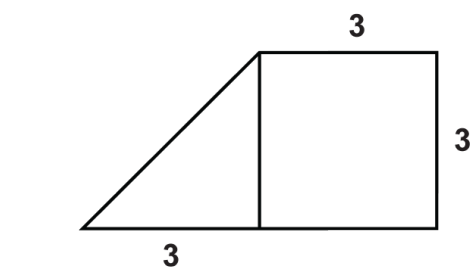
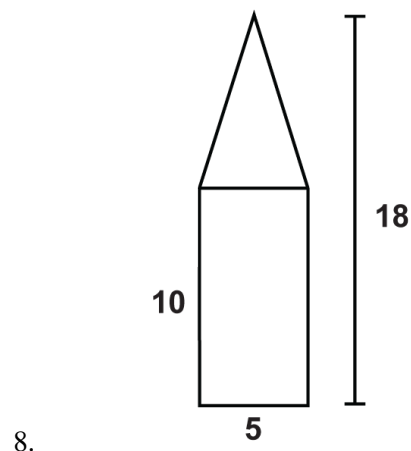

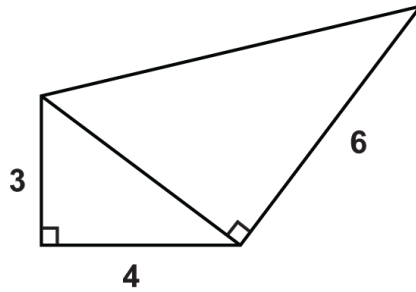

12.

Use the figure to answer the questions.

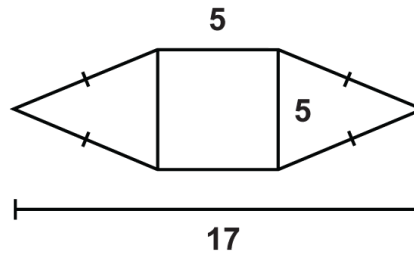

13. What is the area of the square?
14. What is the area of the triangle on the left?
15. What is the area of the composite figure?

10.5 Area and Perimeter of Trapezoids

Here you'll learn how to find the area and perimeter of a trapezoid given its two bases and its height.

What if you were given a trapezoid and the size of its two bases as well as its height? How could you find the total distance around the trapezoid and the amount of space it takes up? After completing this Concept, you'll be able to use the formulas for the perimeter and area of a trapezoid to solve problems like this.

Watch This



MEDIA

Click image to the left for more content.

[Area and Perimeter of Trapezoids CK-12](#)

Guidance

A **trapezoid** is a quadrilateral with one pair of parallel sides. The parallel sides are called the bases and we will refer to the lengths of the bases as b_1 and b_2 . The perpendicular distance between the parallel sides is the height of the trapezoid. The area of a trapezoid is $A = \frac{1}{2}h(b_1 + b_2)$ where h is *always* perpendicular to the bases.

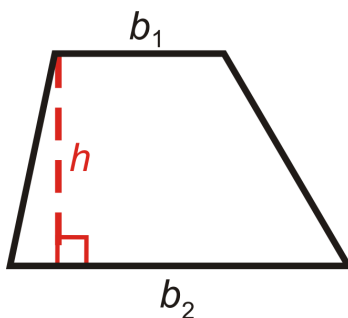

Example A

Find the area of the trapezoid below.

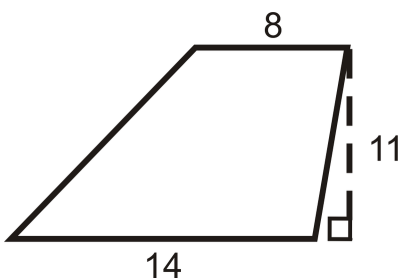

$$A = \frac{1}{2}(11)(14 + 8)$$

$$A = \frac{1}{2}(11)(22)$$

$$A = 121 \text{ units}^2$$

Example B

Find the area of the trapezoid below.

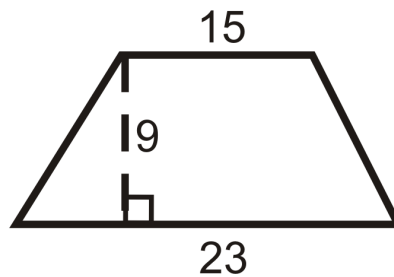

$$A = \frac{1}{2}(9)(15 + 23)$$

$$A = \frac{1}{2}(9)(38)$$

$$A = 171 \text{ units}^2$$

Example C

Find the perimeter and area of the trapezoid.

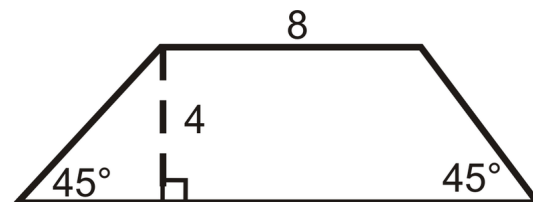

Even though we are not told the length of the second base, we can find it using special right triangles. Both triangles at the ends of this trapezoid are isosceles right triangles, so the hypotenuses are $4\sqrt{2}$ and the other legs are of length 4.

$$P = 8 + 4\sqrt{2} + 16 + 4\sqrt{2}$$

$$P = 24 + 8\sqrt{2} \approx 35.3 \text{ units}$$

$$A = \frac{1}{2}(4)(8 + 16)$$

$$A = 48 \text{ units}^2$$



MEDIA

 Click image to the left for more content.

Area and Perimeter of Trapezoids CK-12

Guided Practice

Find the area of the following shapes. Round your answers to the nearest hundredth.

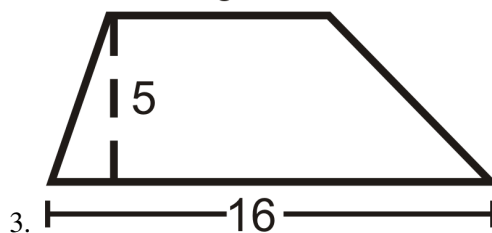
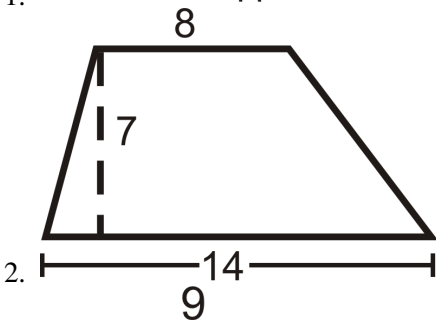
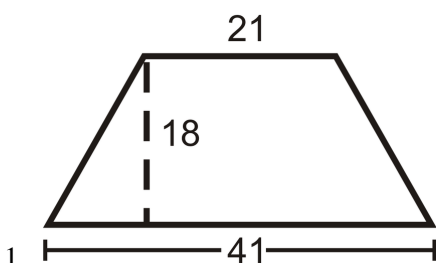

Answers

Use the formula for the area of a trapezoid.

$$1. \frac{1}{2}(18)(41 + 21) = 558 \text{ units}^2.$$

$$2. \frac{1}{2}(7)(14 + 8) = 77 \text{ units}^2.$$

$$3. \frac{1}{2}(5)(16 + 9) = 62.5 \text{ units}^2.$$

Practice

Find the area and perimeter of the following shapes. Round your answers to the nearest hundredth.

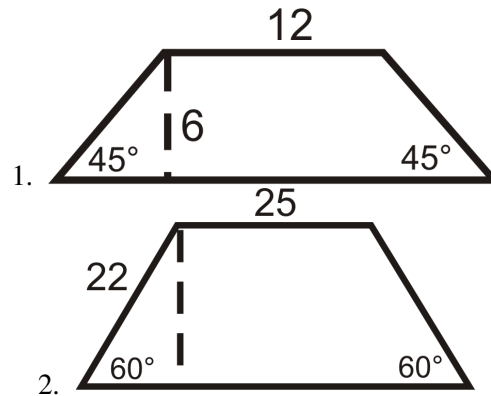

Find the area of the following trapezoids.

3. Trapezoid with bases 3 in and 7 in and height of 3 in.
4. Trapezoid with bases 6 in and 8 in and height of 5 in.
5. Trapezoid with bases 10 in and 26 in and height of 2 in.
6. Trapezoid with bases 15 in and 12 in and height of 10 in.
7. Trapezoid with bases 4 in and 23 in and height of 21 in.
8. Trapezoid with bases 9 in and 4 in and height of 1 in.
9. Trapezoid with bases 12 in and 8 in and height of 16 in.
10. Trapezoid with bases 26 in and 14 in and height of 19 in.

Use the given figures to answer the questions.

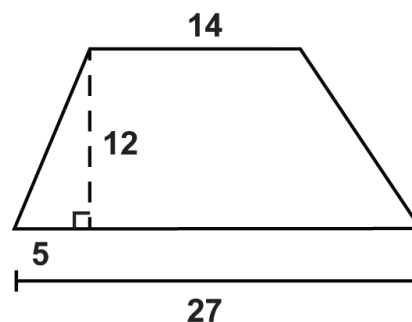

11. What is the perimeter of the trapezoid?
12. What is the area of the trapezoid?

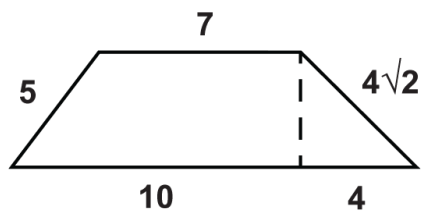

13. What is the perimeter of the trapezoid?
14. What is the area of the trapezoid?

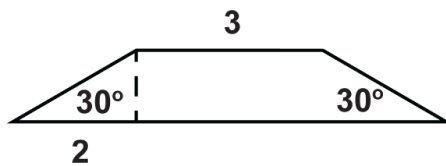

15. What is the perimeter of the trapezoid?
16. What is the area of the trapezoid?

10.6 Area and Perimeter of Rhombuses and Kites

Here you'll learn how to find the area and perimeter of a kite or a rhombus given its two diagonals.

What if you were given a kite or a rhombus and the size of its two diagonals? How could you find the total distance around the kite or rhombus and the amount of space it takes up? After completing this Concept, you'll be able to use the formulas for the perimeter and area of a kite/rhombus to solve problems like this.

Watch This



MEDIA

Click image to the left for more content.

Area and Perimeter of Rhombuses and Kites CK-12

Guidance

Recall that a **rhombus** is a quadrilateral with four congruent sides and a **kite** is a quadrilateral with distinct adjacent congruent sides. Both of these quadrilaterals have perpendicular diagonals, which is how we are going to find their areas.

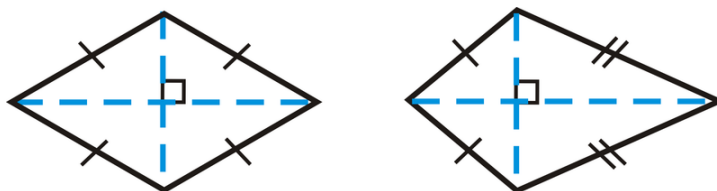

Notice that the diagonals divide each quadrilateral into 4 triangles. If we move the two triangles on the bottom of each quadrilateral so that they match up with the triangles above the horizontal diagonal, we would have two rectangles.

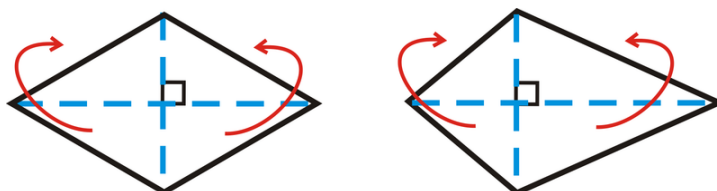

So, the height of these rectangles is half of one of the diagonals and the base is the length of the other diagonal.

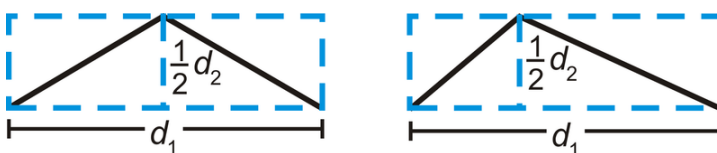

The area of a rhombus or a kite is $A = \frac{1}{2}d_1d_2$

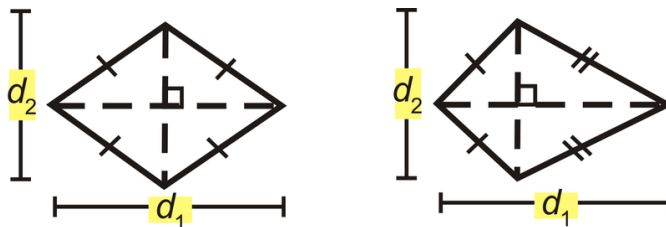

Example A

Find the perimeter and area of the rhombus below.

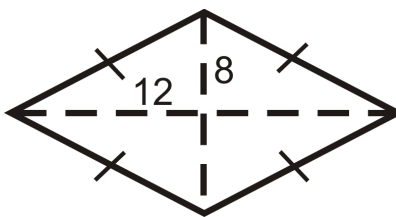

In a rhombus, all four triangles created by the diagonals are congruent.

To find the perimeter, you must find the length of each side, which would be the hypotenuse of one of the four triangles. Use the Pythagorean Theorem.

$$12^2 + 8^2 = side^2$$

$$144 + 64 = side^2$$

$$side = \sqrt{208} = 4\sqrt{13}$$

$$P = 4(4\sqrt{13}) = 16\sqrt{13} \text{ units}$$

$$A = \frac{1}{2} \cdot 16 \cdot 24$$

$$A = 192 \text{ units}^2$$

Example B

Find the perimeter and area of the rhombus below.

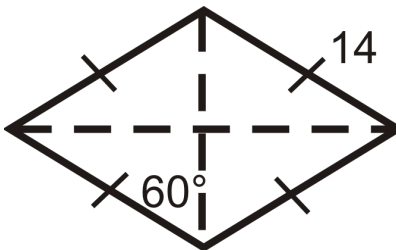

In a rhombus, all four triangles created by the diagonals are congruent.

Here, each triangle is a 30-60-90 triangle with a hypotenuse of 14. From the special right triangle ratios the short leg is 7 and the long leg is $7\sqrt{3}$.

$$P = 4 \cdot 14 = 56 \text{ units}$$

$$A = \frac{1}{2} \cdot 14 \cdot 14\sqrt{3} = 98\sqrt{3} \text{ units}^2$$

Example C

The vertices of a quadrilateral are $A(2, 8)$, $B(7, 9)$, $C(11, 2)$, and $D(3, 3)$. Show $ABCD$ is a kite and find its area.

After plotting the points, it looks like a kite. $AB = AD$ and $BC = DC$. The diagonals are perpendicular if the slopes are negative reciprocals of each other.

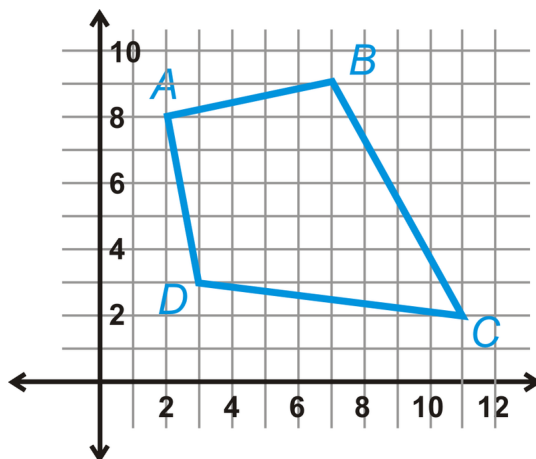

$$m_{AC} = \frac{2-8}{11-2} = -\frac{6}{9} = -\frac{2}{3}$$

$$m_{BD} = \frac{9-3}{7-3} = \frac{6}{4} = \frac{3}{2}$$

The diagonals are perpendicular, so $ABCD$ is a kite. To find the area, we need to find the length of the diagonals, AC and BD .

$$d_1 = \sqrt{(2-11)^2 + (8-2)^2}$$

$$= \sqrt{(-9)^2 + 6^2}$$

$$= \sqrt{81 + 36} = \sqrt{117} = 3\sqrt{13}$$

$$d_2 = \sqrt{(7-3)^2 + (9-3)^2}$$

$$= \sqrt{4^2 + 6^2}$$

$$= \sqrt{16 + 36} = \sqrt{52} = 2\sqrt{13}$$

Plug these lengths into the area formula for a kite. $A = \frac{1}{2} (3\sqrt{13}) (2\sqrt{13}) = 39 \text{ units}^2$



MEDIA

Click image to the left for more content.

[Area and Perimeter of Rhombuses and Kites CK-12](#)

Guided Practice

Find the perimeter and area of the kites below.

1.

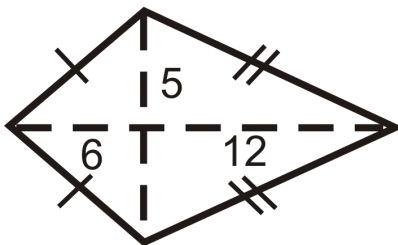

2.

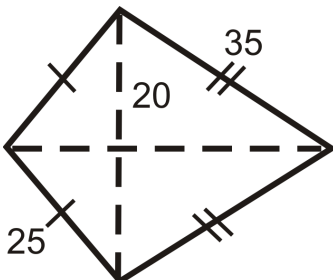

3. Find the area of a rhombus with diagonals of 6 in and 8 in.

Answers:

In a kite, there are two pairs of congruent triangles. Use the Pythagorean Theorem in the first two problems to find the lengths of sides or diagonals.

1.

Shorter sides of kite

$$6^2 + 5^2 = s_1^2$$

$$36 + 25 = s_1^2$$

$$s_1 = \sqrt{61} \text{ units}$$

Longer sides of kite

$$12^2 + 5^2 = s_2^2$$

$$144 + 25 = s_2^2$$

$$s_2 = \sqrt{169} = 13 \text{ units}$$

$$P = 2(\sqrt{61}) + 2(13) = 2\sqrt{61} + 26 \approx 41.6 \text{ units}$$

$$A = \frac{1}{2}(10)(18) = 90 \text{ units}$$

2.

Smaller diagonal portion

$$20^2 + d_s^2 = 25^2$$

$$d_s^2 = 225$$

$$d_s = 15 \text{ units}$$

Larger diagonal portion

$$20^2 + d_l^2 = 35^2$$

$$d_l^2 = 825$$

$$d_l = 5\sqrt{33} \text{ units}$$

$$A = \frac{1}{2}(15 + 5\sqrt{33})(40) \approx 874.5 \text{ units}^2$$

$$P = 2(25) + 2(35) = 120 \text{ units}$$

3. The area is $\frac{1}{2}(8)(6) = 24 \text{ in}^2$.

Practice

1. Do you think all rhombi and kites with the same diagonal lengths have the same area? *Explain* your answer.

Find the area of the following shapes. *Round your answers to the nearest hundredth.*

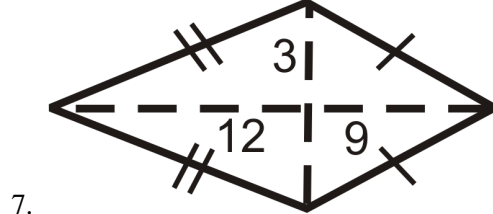
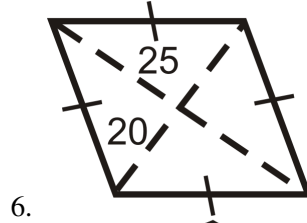
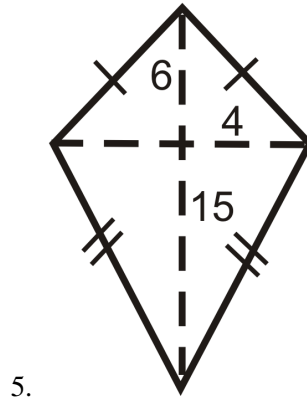
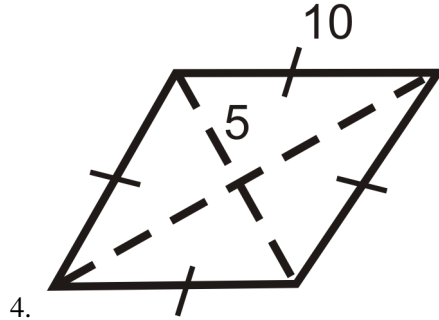
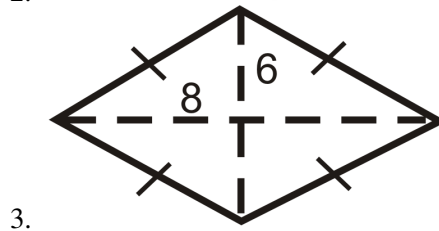
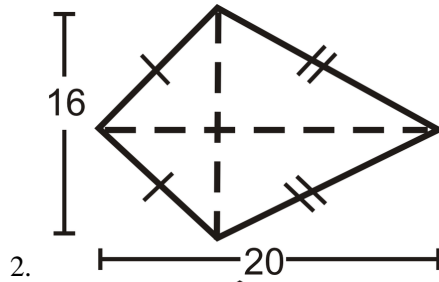

Find the area and perimeter of the following shapes. Round your answers to the nearest hundredth.

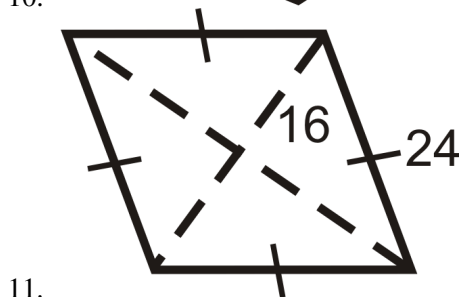
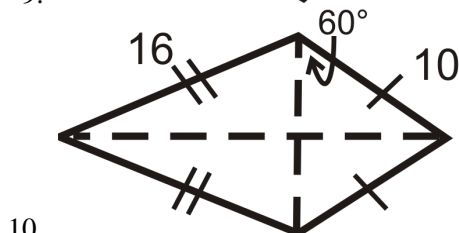
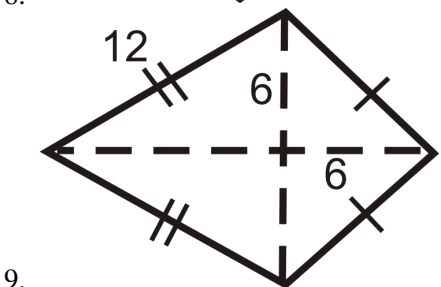
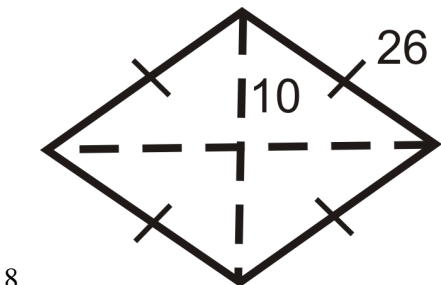

For Questions 12 and 13, the area of a rhombus is 32 units^2 .

12. What would the product of the diagonals have to be for the area to be 32 units^2 ?
13. List two possibilities for the length of the diagonals, based on your answer from #12.

For Questions 14 and 15, the area of a kite is 54 units^2 .

14. What would the product of the diagonals have to be for the area to be 54 units^2 ?
15. List two possibilities for the length of the diagonals, based on your answer from #14.

Sherry designed the logo for a new company, made up of 3 congruent kites.

16. What are the lengths of the diagonals for one kite?
17. Find the area of one kite.
18. Find the area of the entire logo.

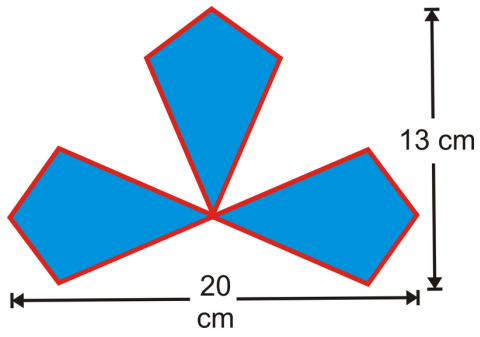

10.7 Area and Perimeter of Similar Polygons

Here you'll learn that the ratio of the perimeters of similar figures is equal to their scale factor and that the ratio of their areas is equal to the square of their scale factor.

What if you were given two similar triangles and told what the scale factor of their sides was? How could you find the ratio of their perimeters and the ratio of their areas? After completing this Concept, you'll be able to use the Area of Similar Polygons Theorem to solve problems like this.

Watch This



MEDIA

Click image to the left for more content.

[Area and Perimeter of Similar Polygons CK-12](#)

Guidance

Polygons are **similar** when their corresponding angles are equal and their corresponding sides are in the same proportion. Just as their corresponding sides are in the same proportion, perimeters and areas of similar polygons have a special relationship.

Perimeters: The ratio of the perimeters is the same as the scale factor. In fact, the ratio of any part of two similar shapes (diagonals, medians, midsegments, altitudes, etc.) is the same as the scale factor.

Areas: If the scale factor of the sides of two similar polygons is $\frac{m}{n}$, then the ratio of the areas is $(\frac{m}{n})^2$ (**Area of Similar Polygons Theorem**). You square the ratio because area is a two-dimensional measurement.

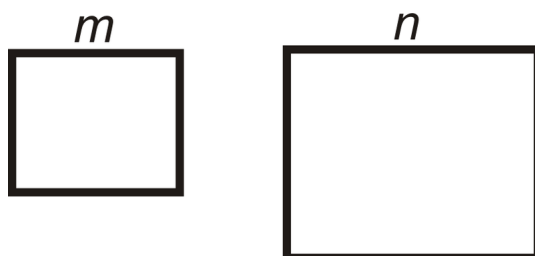

Example A

The two rectangles below are similar. Find the scale factor and the ratio of the perimeters and verify that the two results are the same.

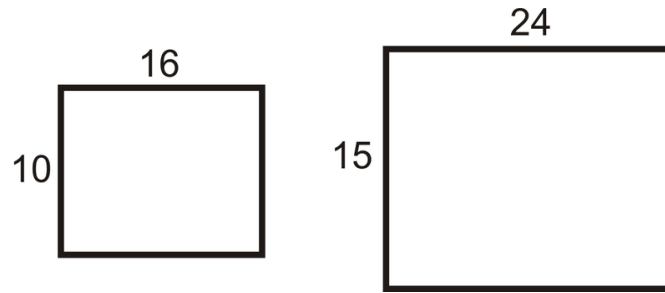

The scale factor is $\frac{16}{24} = \frac{2}{3}$.

$$P_{small} = 2(10) + 2(16) = 52 \text{ units}$$

$$P_{large} = 2(15) + 2(24) = 78 \text{ units}$$

The ratio of the perimeters is $\frac{52}{78} = \frac{2}{3}$.

Example B

Find the area of each rectangle from Example A. Then, find the ratio of the areas and verify that it fits the Area of Similar Polygons Theorem.

$$A_{small} = 10 \cdot 16 = 160 \text{ units}^2$$

$$A_{large} = 15 \cdot 24 = 360 \text{ units}^2$$

The ratio of the areas would be $\frac{160}{360} = \frac{4}{9}$.

The ratio of the sides, or scale factor is $\frac{2}{3}$ and the ratio of the areas is $\frac{4}{9}$. Notice that the ratio of the areas is the **square** of the scale factor.

Example C

Find the ratio of the areas of the rhombi below. The rhombi are similar.

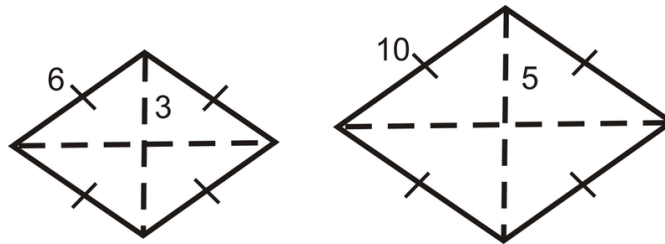

Find the ratio of the sides and square it.

$$\left(\frac{3}{5}\right)^2 = \frac{9}{25}$$



MEDIA

Click image to the left for more content.

Area and Perimeter of Similar Polygons CK-12

Guided Practice

- Two trapezoids are similar. If the scale factor is $\frac{3}{4}$ and the area of the smaller trapezoid is 81 cm^2 , what is the area of the larger trapezoid?
- Two triangles are similar. The ratio of the areas is $\frac{25}{64}$. What is the scale factor?
- Using the ratios from #2, find the length of the base of the smaller triangle if the length of the base of the larger triangle is 24 units.

Answers:

- First, the ratio of the areas is $(\frac{3}{4})^2 = \frac{9}{16}$. Now, we need the area of the larger trapezoid. To find this, set up a proportion using the area ratio.

$$\frac{9}{16} = \frac{81}{A} \rightarrow 9A = 1296$$

$$A = 144 \text{ cm}^2$$

- The scale factor is $\sqrt{\frac{25}{64}} = \frac{5}{8}$.

- Set up a proportion using the scale factor.

$$\frac{5}{8} = \frac{b}{24} \rightarrow 8b = 120$$

$$b = 15 \text{ units}$$

Practice

Determine the ratio of the areas, given the ratio of the sides of a polygon.

- $\frac{3}{5}$
- $\frac{1}{4}$
- $\frac{7}{2}$
- $\frac{6}{11}$

Determine the ratio of the sides of a polygon, given the ratio of the areas.

- $\frac{1}{36}$
- $\frac{4}{81}$
- $\frac{49}{9}$
- $\frac{25}{144}$

This is an equilateral triangle made up of 4 congruent equilateral triangles.

9. What is the ratio of the areas of the large triangle to one of the small triangles?

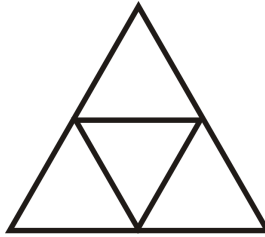

10. What is the scale factor of large to small triangle?
 11. If the area of the large triangle is 20 units^2 , what is the area of a small triangle?
 12. If the length of the altitude of a small triangle is $2\sqrt{3}$, find the perimeter of the large triangle.

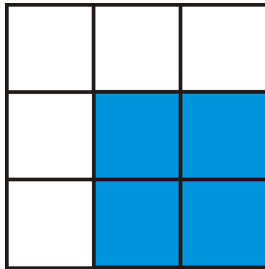

13. Find the perimeter of the large square and the blue square.
 14. Find the scale factor of the blue square and large square.
 15. Find the ratio of their perimeters.
 16. Find the area of the blue and large squares.
 17. Find the ratio of their areas.
 18. Find the length of the diagonals of the blue and large squares. Put them into a ratio. Which ratio is this the same as?
 19. Two rectangles are similar with a scale factor of $\frac{4}{7}$. If the area of the larger rectangle is 294 in^2 , find the area of the smaller rectangle.
 20. Two triangles are similar with a scale factor of $\frac{1}{3}$. If the area of the smaller triangle is 22 ft^2 , find the area of the larger triangle.
 21. The ratio of the areas of two similar squares is $\frac{16}{81}$. If the length of a side of the smaller square is 24 units, find the length of a side in the larger square.
 22. The ratio of the areas of two right triangles is $\frac{4}{9}$. If the length of the hypotenuse of the larger triangle is 48 units, find the length of the smaller triangle's hypotenuse.

Questions 23-26 build off of each other. You may assume the problems are connected.

23. Two similar rhombi have areas of 72 units^2 and 162 units^2 . Find the ratio of the areas.
 24. Find the scale factor.
 25. The diagonals in these rhombi are congruent. Find the length of the diagonals and the sides.
 26. What type of rhombi are these quadrilaterals?

10.8 Circumference

Here you'll learn how to find the distance around, or the circumference of, a circle.

What if you were given the radius or diameter of a circle? How could you find the distance around that circle? After completing this Concept, you'll be able to use the formula for circumference to solve problems like this one.

Watch This



MEDIA

Click image to the left for more content.

Circumference CK-12

Guidance

Circumference is the distance around a circle. The circumference can also be called the perimeter of a circle. However, we use the term circumference for circles because they are round.

Circumference Formula: $C = \pi d$ where the diameter $d = 2r$, or twice the radius. So $C = 2\pi r$ as well.

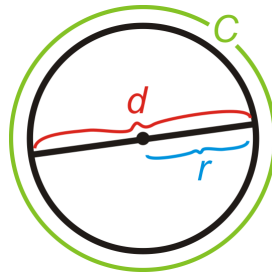

π , or “**pi**” is the ratio of the circumference of a circle to its diameter. It is approximately equal to 3.14159265358979323846...

To see more digits of π , go to <http://www.eveandersson.com/pi/digits/>. You should have a π button on your calculator. If you don't, you can use 3.14 as an approximation for π . You can also leave your answers in terms of π for many problems.

Example A

Find the circumference of a circle with a radius of 7 cm.

Plug the radius into the formula.

$$C = 2\pi(7) = 14\pi \approx 44 \text{ cm}$$

Example B

The circumference of a circle is 64π units. Find the diameter.

Again, you can plug in what you know into the circumference formula and solve for d .

$$64\pi = \pi d$$
$$64 \text{ units} = d$$

Example C

A circle is inscribed in a square with 10 in. sides. What is the circumference of the circle? Leave your answer in terms of π .

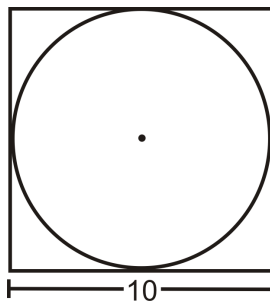

From the picture, we can see that the diameter of the circle is equal to the length of a side. $C = 10\pi$ in.

**MEDIA**

Click image to the left for more content.

[Circumference CK-12](#)

Guided Practice

1. Find the perimeter of the square in Example C. Is it more or less than the circumference of the circle? Why?
2. The tires on a compact car are 18 inches in diameter. How far does the car travel after the tires turn once? How far does the car travel after 2500 rotations of the tires?



3. Find the radius of circle with circumference 88 in.

Answers:

1. The perimeter is $P = 4(10) = 40$ in. In order to compare the perimeter with the circumference we should change the circumference into a decimal.

$C = 10\pi \approx 31.42$ in. This is less than the perimeter of the square, which makes sense because the circle is inside the square.

2. One turn of the tire is the circumference. This would be $C = 18\pi \approx 56.55$ in. 2500 rotations would be $2500 \cdot 56.55$ in approx 141,375 in, 11,781 ft, or 2.23 miles.

3. Use the formula for circumference and solve for the radius.

$$C = 2\pi r$$

$$88 = 2\pi r$$

$$\frac{44}{\pi} = r$$

$$r \approx 14 \text{ in}$$

Practice

Fill in the following table. Leave all answers in terms of π .

TABLE 10.1:

	<i>diameter</i>	<i>radius</i>	<i>circumference</i>
1.	15		
2.		4	
3.	6		
4.			84π
5.		9	
6.			25π
7.			2π
8.	36		

9. Find the circumference of a circle with $d = \frac{20}{\pi}$ cm.

Square PQSR is inscribed in $\odot T$. $RS = 8\sqrt{2}$.

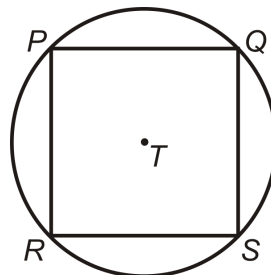

10. Find the length of the diameter of $\odot T$.

11. How does the diameter relate to PQSR?

12. Find the perimeter of $PQSR$.
13. Find the circumference of $\odot T$.

For questions 14-17, a truck has tires with a 26 in diameter.

14. How far does the truck travel every time a tire turns exactly once? What is this the same as?
15. How many times will the tire turn after the truck travels 1 mile? (1 mile = 5280 feet)
16. The truck has travelled 4072 tire rotations. How many miles is this?
17. The average recommendation for the life of a tire is 30,000 miles. How many rotations is this?

10.9 Arc Length

Here you'll learn how to use a circle's circumference to find the length of an arc.

What if you were given the angle measure of a circle's arc? How could you find the length of that arc? After completing this Concept, you'll be able to find an arc's length, or its portion of a circle's circumference.

Watch This



MEDIA

Click image to the left for more content.

Arc Length CK-12

Guidance

One way to measure arcs is in degrees. This is called the “arc measure” or “degree measure” (see [Arcsin Circles](#)). Arcs can also be measured in length, as a portion of the circumference. **Arc length** is the length of an arc or a portion of a circle's circumference. The arc length is directly related to the degree arc measure.

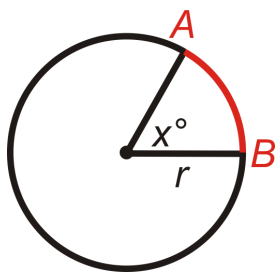

Arc Length Formula: The length of $\widehat{AB} = \frac{m\widehat{AB}}{360^\circ} \cdot \pi d$ or $\frac{m\widehat{AB}}{360^\circ} \cdot 2\pi r$.

Example A

Find the length of \widehat{PQ} . Leave your answer in terms of π .

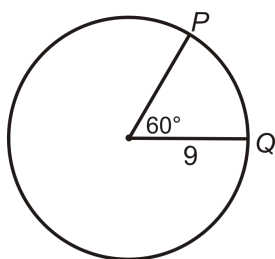

In the picture, the central angle that corresponds with \widehat{PQ} is 60° . This means that $m\widehat{PQ} = 60^\circ$. Think of the arc length as a portion of the circumference. There are 360° in a circle, so 60° would be $\frac{1}{6}$ of that ($\frac{60^\circ}{360^\circ} = \frac{1}{6}$). Therefore, the length of \widehat{PQ} is $\frac{1}{6}$ of the circumference. $length\ of\ \widehat{PQ} = \frac{1}{6} \cdot 2\pi(9) = 3\pi$ units.

Example B

The arc length of a circle is $\widehat{AB} = 6\pi$ and is $\frac{1}{4}$ the circumference. Find the radius of the circle.

If 6π is $\frac{1}{4}$ the circumference, then the total circumference is $4(6\pi) = 24\pi$. To find the radius, plug this into the circumference formula and solve for r .

$$24\pi = 2\pi r$$

$$12\ units = r$$

Example C

Find the measure of the central angle or \widehat{PQ} .

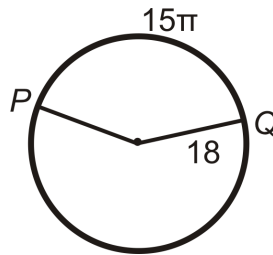

Let's plug in what we know to the Arc Length Formula.

$$15\pi = \frac{m\widehat{PQ}}{360^\circ} \cdot 2\pi(18)$$

$$15 = \frac{m\widehat{PQ}}{10^\circ}$$

$$150^\circ = m\widehat{PQ}$$



MEDIA

Click image to the left for more content.

Arc Length CK-12

Guided Practice

Find the arc length of \widehat{PQ} in $\odot A$. Leave your answers in terms of π .

1.

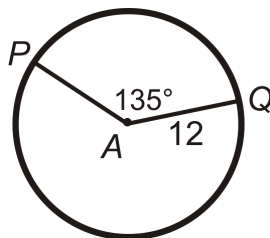

2.

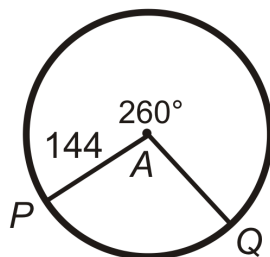

3. A typical large pizza has a diameter of 14 inches and is cut into 8 pieces. Think of the crust as the circumference of the pizza. Find the *length* of the crust for the entire pizza. Then, find the length of the crust for one piece of pizza if the entire pizza is cut into 8 pieces.

**Answers:**

1. Use the Arc Length formula.

$$\widehat{PQ} = \frac{135}{360} \cdot 2\pi(12)$$

$$\widehat{PQ} = \frac{3}{8} \cdot 24\pi$$

$$\widehat{PQ} = 9\pi$$

2. Use the Arc Length formula.

$$\widehat{PQ} = \frac{360 - 260}{360} \cdot 2\pi(144)$$

$$\widehat{PQ} = \frac{5}{18} \cdot 288\pi$$

$$\widehat{PQ} = 80\pi$$

3. The entire length of the crust, or the circumference of the pizza, is $14\pi \approx 44$ in. In $\frac{1}{8}$ of the pizza, one piece would have $\frac{44}{8} \approx 5.5$ inches of crust.

Practice

Find the arc length of \widehat{PQ} in $\odot A$. Leave your answers in terms of π .

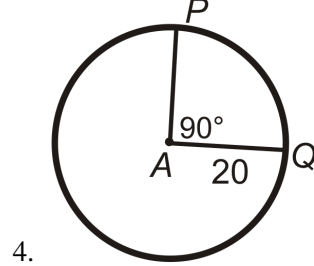
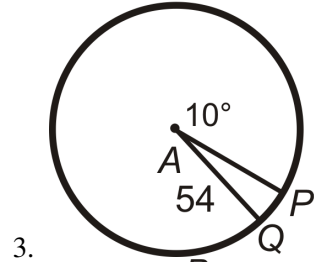
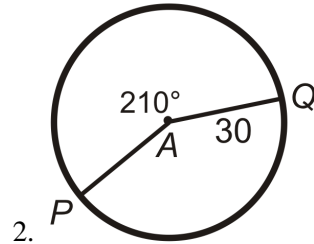
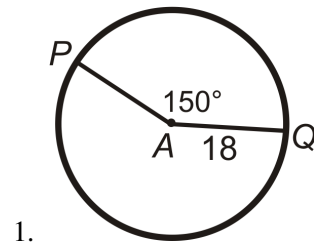

Find PA (the radius) in $\odot A$. Leave your answer in terms of π .

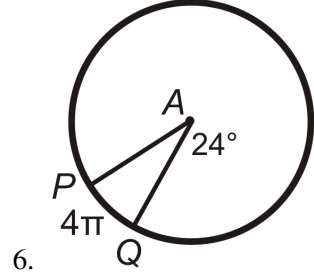
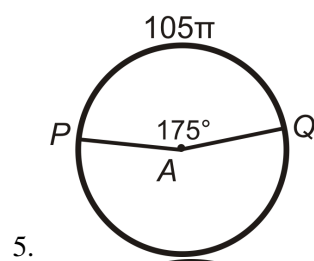

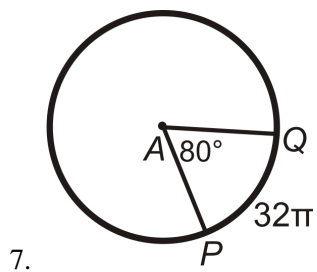

Find the central angle or $m\widehat{PQ}$ in $\odot A$. Round any decimal answers to the nearest tenth.

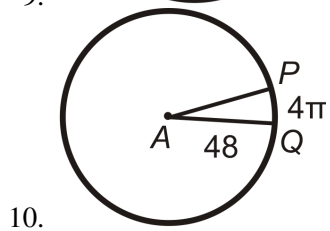
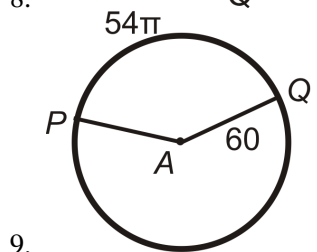
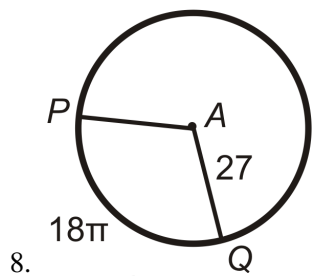

10.10 Area of a Circle

Here you'll learn how to find the area of a circle given its radius or diameter.

What if you were given the radius or diameter of a circle? How could you find the amount of space the circle takes up? After completing this Concept, you'll be able to use the formula for the area of a circle to solve problems like this.

Watch This



MEDIA

Click image to the left for more content.

[Area of a Circle CK-12](#)

Guidance



MEDIA

Click image to the left for more content.

To find the area of a circle, all you need to know is its radius. If r is the radius of a circle, then its **area** is $A = \pi r^2$.

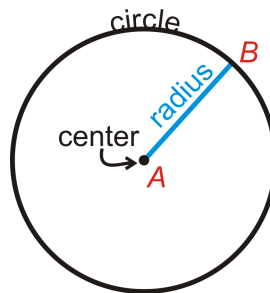

We will leave our answers in terms of π , unless otherwise specified. To see a derivation of this formula, see <http://www.rkm.com.au/ANIMATIONS/animation-Circle-Area-Derivation.html>, by Russell Knightley.

Example A

Find the area of a circle with a diameter of 12 cm.

If $d = 12$ cm, then $r = 6$ cm. The area is $A = \pi (6^2) = 36\pi$ cm².

Example B

If the area of a circle is 20π units, what is the radius?

Plug in the area and solve for the radius.

$$\begin{aligned} 20\pi &= \pi r^2 \\ 20 &= r^2 \\ r &= \sqrt{20} = 2\sqrt{5} \text{ units} \end{aligned}$$

Example C

A circle is inscribed in a square. Each side of the square is 10 cm long. What is the area of the circle?

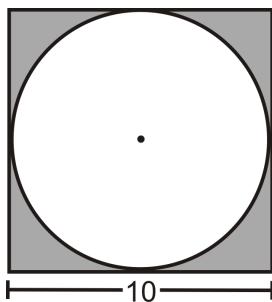

The diameter of the circle is the same as the length of a side of the square. Therefore, the radius is 5 cm.

$$A = \pi 5^2 = 25\pi \text{ cm}^2$$



MEDIA

Click image to the left for more content.

[Area of a Circle CK-12](#)

Guided Practice

1. Find the area of the shaded region from Example C.
2. Find the diameter of a circle with area 36π .
3. Find the area of a circle with diameter 20 inches.

Answers:

1. The area of the shaded region would be the area of the square minus the area of the circle.

$$A = 10^2 - 25\pi = 100 - 25\pi \approx 21.46 \text{ cm}^2$$

2. First, use the formula for the area of a circle to solve for the radius of the circle.

$$\begin{aligned} A &= \pi r^2 \\ 36\pi &= \pi r^2 \\ 36 &= r^2 \\ r &= 6 \end{aligned}$$

If the radius is 6 units, then the diameter is 12 units.

3. If the diameter is 20 inches that means that the radius is 10 inches. Now we can use the formula for the area of a circle. $A = \pi(10)^2 = 100\pi \text{ in}^2$.

Practice

Fill in the following table. Leave all answers in terms of π .

TABLE 10.2:

	<i>radius</i>	<i>Area</i>	<i>circumference</i>
1.	2		
2.		16π	
3.			10π
4.			24π
5.	9		
6.		90π	
7.			35π
8.	$\frac{7}{\pi}$		
9.			60
10.		36	

Find the area of the shaded region. Round your answer to the nearest hundredth.

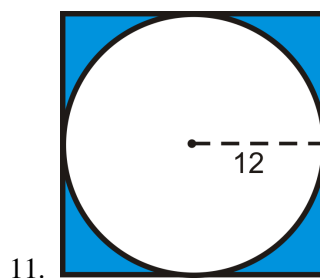

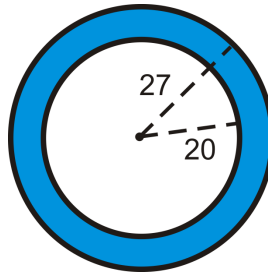

12.

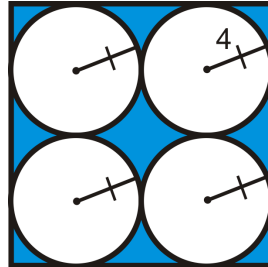

13.

10.11 Area of Sectors and Segments

Here you'll learn how to find the area of a circle portion that is bounded by either two radii or a chord.

What if you were given a circle with two radii in which the region between those two radii was shaded? How could you find the area of that shaded region of the circle? After completing this Concept, you'll be able to use the formula for the area of a circle's sector to solve problems like this one.

Watch This



MEDIA

Click image to the left for more content.

[Area of Sectors and Segments CK-12](#)

Guidance

A **sector of a circle** is the area bounded by two radii and the arc between the endpoints of the radii. If r is the radius and \widehat{AB} is the arc bounding a sector, then the **area** of the sector is $A = \frac{m\widehat{AB}}{360^\circ} \cdot \pi r^2$.



A **segment of a circle** is the area of a circle that is bounded by a chord and the arc with the same endpoints as the chord. The **area** of a segment is $A_{\text{segment}} = A_{\text{sector}} - A_{\triangle ABC}$

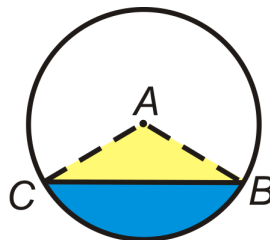

Example A

Find the area of the blue sector. Leave your answer in terms of π .

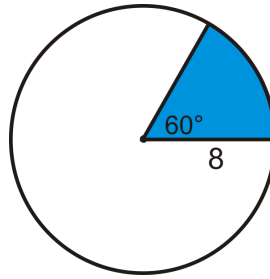

In the picture, the central angle that corresponds with the sector is 60° . 60° is $\frac{1}{6}$ of 360° , so this sector is $\frac{1}{6}$ of the total area. $\text{area of blue sector} = \frac{1}{6} \cdot \pi 8^2 = \frac{32}{3}\pi$

Example B

The area of a sector is 8π and the radius of the circle is 12. What is the central angle?

Plug in what you know to the sector area formula and then solve for the central angle, which we will call x .

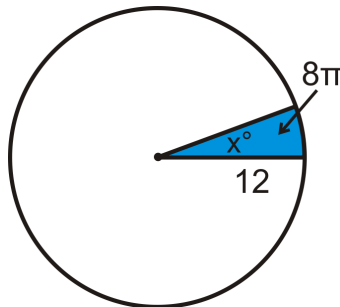

$$\begin{aligned} 8\pi &= \frac{x}{360^\circ} \cdot \pi 12^2 \\ 8\pi &= \frac{x}{360^\circ} \cdot 144\pi \\ 8 &= \frac{2x}{5} \\ x &= 8 \cdot \frac{5}{2} = 20^\circ \end{aligned}$$

Example C

Find the area of the blue segment below.

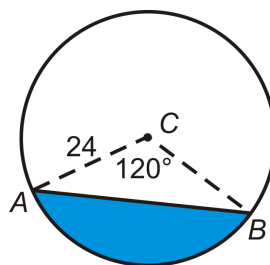

The area of the segment is the area of the sector minus the area of the isosceles triangle made by the radii. If we split the isosceles triangle in half, each half is a 30-60-90 triangle, where the radius is the hypotenuse. The height of $\triangle ABC$ is 12 and the base is $2(12\sqrt{3}) = 24\sqrt{3}$.

$$\begin{aligned} A_{\text{sector}} &= \frac{120}{360}\pi \cdot 24^2 \\ &= 192\pi \end{aligned}$$

$$\begin{aligned} A_{\triangle} &= \frac{1}{2}(24\sqrt{3})(12) \\ &= 144\sqrt{3} \end{aligned}$$

The area of the segment is $A = 192\pi - 144\sqrt{3} \approx 353.8$ units.



MEDIA

Click image to the left for more content.

[Area of Sectors and Segments CK-12](#)

Guided Practice

1. The area of a sector is 135π and the arc measure is 216° . What is the radius of the circle?

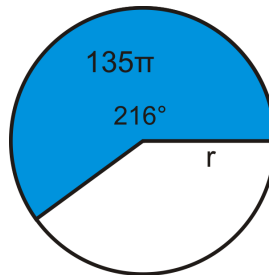

2. Find the area of the shaded region. The quadrilateral is a square.

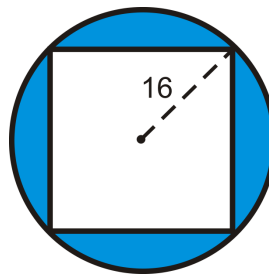

3. Find the area of the blue sector of $\odot A$.

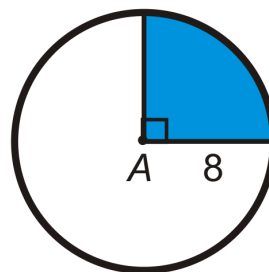

Answers:

1. Plug in what you know to the sector area formula and solve for r .

$$135\pi = \frac{216^\circ}{360^\circ} \cdot \pi r^2$$

$$135 = \frac{3}{5} \cdot r^2$$

$$\frac{5}{3} \cdot 135 = r^2$$

$$225 = r^2 \rightarrow r = \sqrt{225} = 15$$

2. The radius of the circle is 16, which is also half of the diagonal of the square. So, the diagonal is 32 and the sides would be $\frac{32}{\sqrt{2}} \cdot \frac{\sqrt{2}}{\sqrt{2}} = 16\sqrt{2}$ because each half of a square is a 45-45-90 triangle.

$$A_{\text{circle}} = 16^2\pi = 256\pi$$

$$A_{\text{square}} = (16\sqrt{2})^2 = 256 \cdot 2 = 512$$

The area of the shaded region is $256\pi - 512 \approx 292.25$

3. The right angle tells us that this sector represents $\frac{1}{4}$ of the circle. The area of the whole circle is $A = \pi 8^2 = 64\pi$. So, the area of the sector is $\frac{1}{4}64\pi = 16\pi$.

Practice

Find the area of the blue sector or segment in $\odot A$. Leave your answers in terms of π . Round any decimal answers to the nearest hundredth.

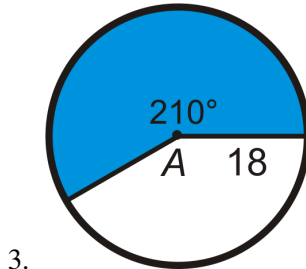
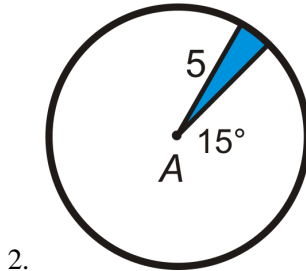
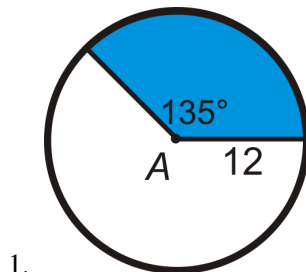

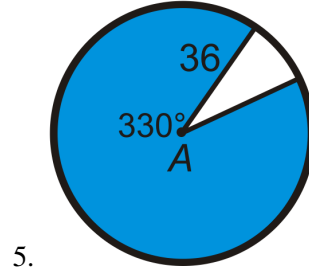
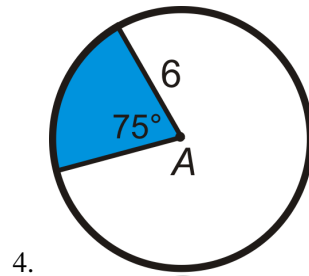

Find the radius of the circle. Leave your answer in terms of π .

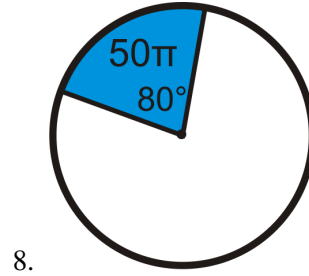
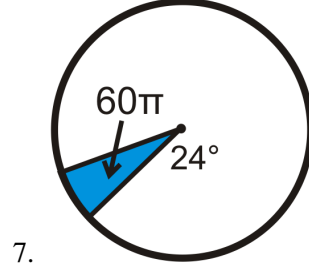
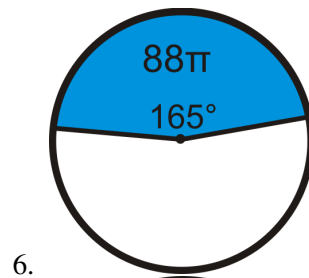

Find the central angle of each blue sector. Round any decimal answers to the nearest tenth.

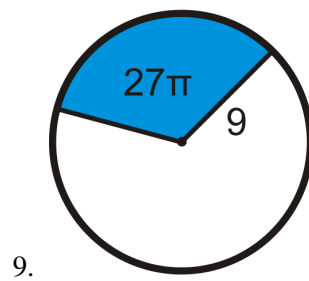

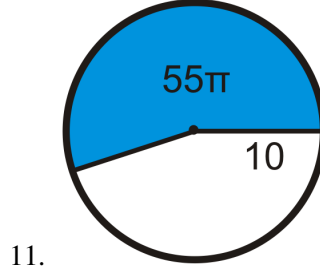
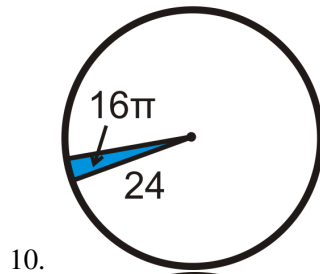

12. Find the area of the sector in $\odot A$. Leave your answer in terms of π .

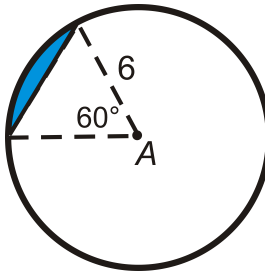

- 13. Find the area of the equilateral triangle.
- 14. Find the area of the segment. Round your answer to the nearest hundredth.
- 15. Find the area of the sector in $\odot A$. Leave your answer in terms of π .
- 16. Find the area of the right triangle.

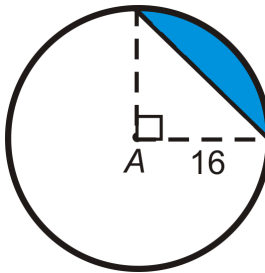

17. Find the area of the segment. Round your answer to the nearest hundredth.

Summary

This chapter covers perimeter and area of all the basic geometric figures. Perimeter and area are compared and calculated for rectangles, parallelograms, triangles, and then for composite shapes of those figures. The chapter then branches into perimeter and area for other special geometric figures, namely trapezoids, rhombuses, and kites, as well as similar polygons. The chapter continues with the circumference of circles and arc length followed by the area of a circle and the area of sectors and segments. The chapter wraps up with area and perimeter of regular polygons.

CHAPTER **11** Surface Area and Volume

Chapter Outline

- 11.1 POLYHEDRONS
 - 11.2 CROSS-SECTIONS AND NETS
 - 11.3 PRISMS
 - 11.4 CYLINDERS
 - 11.5 PYRAMIDS
 - 11.6 CONES
 - 11.7 SPHERES
 - 11.8 COMPOSITE SOLIDS
 - 11.9 AREA AND VOLUME OF SIMILAR SOLIDS
-

Introduction

In this chapter we extend what we know about two-dimensional figures to three-dimensional shapes. First, we will define the different types of 3D shapes and their parts. Then, we will find the surface area and volume of prisms, cylinders, pyramids, cones, and spheres.

11.1 Polyhedrons

Here you'll learn what a polyhedron is and the parts of a polyhedron. You'll then use these parts in a formula called Euler's Theorem.

What if you were given a solid three-dimensional figure, like a carton of ice cream? How could you determine how the faces, vertices, and edges of that figure are related? After completing this Concept, you'll be able to use Euler's Theorem to answer that question.

Watch This



MEDIA

Click image to the left for more content.

Polyhedrons CK-12

Guidance

A **polyhedron** is a 3-dimensional figure that is formed by polygons that enclose a region in space. Each polygon in a polyhedron is a **face**. The line segment where two faces intersect is an **edge**. The point of intersection of two edges is a **vertex**.

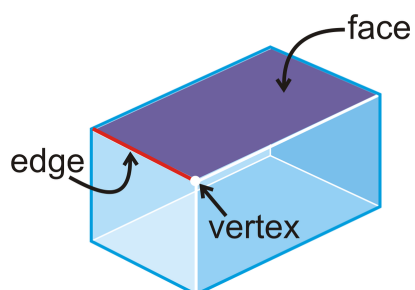

Examples of polyhedrons include a cube, prism, or pyramid. Cones, spheres, and cylinders are not polyhedrons because they have surfaces that are not polygons. The following are more examples of polyhedrons:

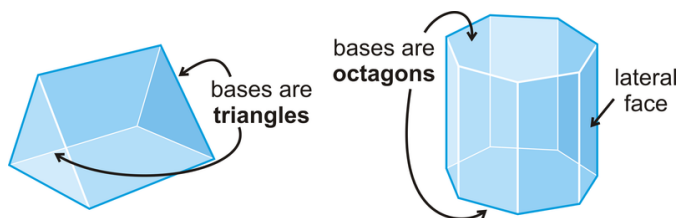

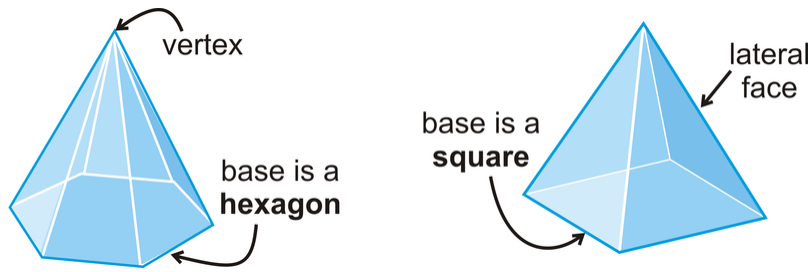

The number of faces (F), vertices (V) and edges (E) are related in the same way for any polyhedron. Their relationship was discovered by the Swiss mathematician Leonhard Euler, and is called Euler's Theorem.

Euler's Theorem: $F + V = E + 2$.

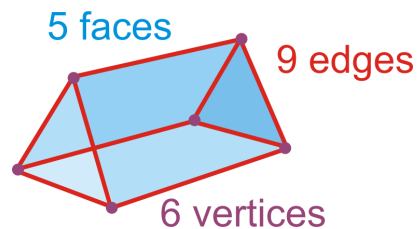

$$\begin{aligned} \text{Faces} + \text{Vertices} &= \text{Edges} + 2 \\ 5 + 6 &= 9 + 2 \end{aligned}$$

A **regular polyhedron** is a polyhedron where all the faces are congruent regular polygons. There are only *five regular polyhedra*, called the *Platonic solids*.

1. **Regular Tetrahedron:** A 4-faced polyhedron and all the faces are equilateral triangles.
2. **Cube:** A 6-faced polyhedron and all the faces are squares.
3. **Regular Octahedron:** An 8-faced polyhedron and all the faces are equilateral triangles.
4. **Regular Dodecahedron:** A 12-faced polyhedron and all the faces are regular pentagons.
5. **Regular Icosahedron:** A 20-faced polyhedron and all the faces are equilateral triangles.

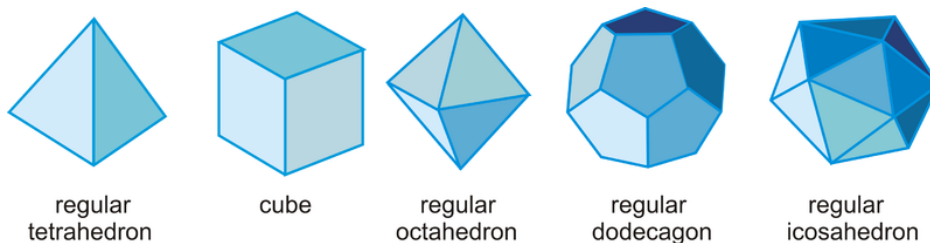

Example A

Determine if the following solids are polyhedrons. If the solid is a polyhedron, name it and find the number of faces, edges and vertices it has.

a)

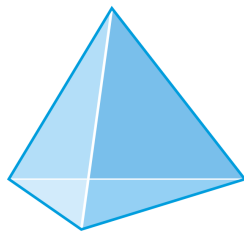

b)

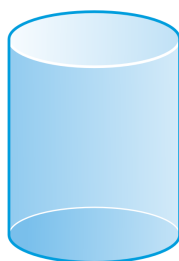

c)

**Answer:**

- a) The base is a triangle and all the sides are triangles, so this is a triangular pyramid, which is also known as a **tetrahedron**. There are 4 faces, 6 edges and 4 vertices.
- b) This solid is also a polyhedron. The bases are both pentagons, so it is a pentagonal prism. There are 7 faces, 15 edges, and 10 vertices.
- c) The bases are circles. Circles are not polygons, so it is not a polyhedron.

Example B

Find the number of faces, vertices, and edges in an octagonal prism.

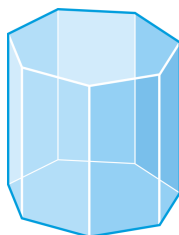

There are 10 faces and 16 vertices. Use Euler's Theorem, to solve for E .

$$\begin{aligned}
 F + V &= E + 2 \\
 10 + 16 &= E + 2 \\
 24 &= E
 \end{aligned}$$

Therefore, there are 24 edges.

Example C

A *truncated icosahedron* is a polyhedron with 12 regular pentagonal faces, 20 regular hexagonal faces, and 90 edges. This icosahedron closely resembles a soccer ball. How many vertices does it have? Explain your reasoning.



We can use Euler's Theorem to solve for the number of vertices.

$$\begin{aligned}
 F + V &= E + 2 \\
 32 + V &= 90 + 2 \\
 V &= 60
 \end{aligned}$$

Therefore, it has 60 vertices.



MEDIA

Click image to the left for more content.

Polyhedrons CK-12

Guided Practice

1. In a six-faced polyhedron, there are 10 edges. How many vertices does the polyhedron have?
2. Markus counts the edges, faces, and vertices of a polyhedron. He comes up with 10 vertices, 5 faces, and 12 edges. Did he make a mistake?
3. Is this a polyhedron? Explain.

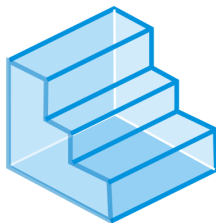
**Answers:**

1. Solve for V in Euler's Theorem.

$$\begin{aligned} F + V &= E + 2 \\ 6 + V &= 10 + 2 \\ V &= 6 \end{aligned}$$

Therefore, there are 6 vertices.

2. Plug all three numbers into Euler's Theorem.

$$\begin{aligned} F + V &= E + 2 \\ 5 + 10 &= 12 + 2 \\ 15 &\neq 14 \end{aligned}$$

Because the two sides are not equal, Markus made a mistake.

3. All of the faces are polygons, so this is a polyhedron. Notice that even though not all of the faces are regular polygons, the number of faces, vertices, and edges still works with Euler's Theorem.

Practice

Complete the table using Euler's Theorem.

TABLE 11.1:

	<i>Name</i>	<i>Faces</i>	<i>Edges</i>	<i>Vertices</i>
1.	Rectangular Prism	6	12	
2.	Octagonal Pyramid		16	9
3.	Regular Icosahedron	20		12
4.	Cube		12	8
5.	Triangular Pyramid	4		4
6.	Octahedron	8	12	
7.	Heptagonal Prism		21	14
8.	Triangular Prism	5	9	

Determine if the following figures are polyhedra. If so, name the figure and find the number of faces, edges, and vertices.

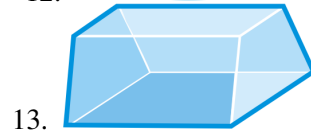
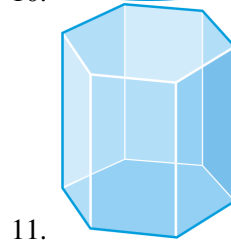
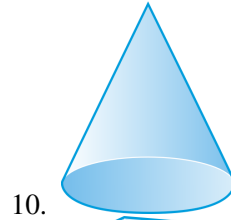
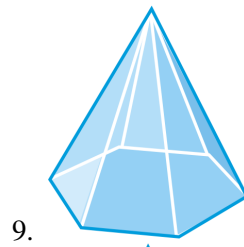

11.2 Cross-Sections and Nets

Here you'll learn different ways of representing three-dimensional objects in two dimensions. In particular, you'll learn about cross-sections and nets.

What if you were given a three-dimensional figure like a pyramid and you wanted to know what that figure would look like in two dimensions? What would a flat slice or an unfolded flat representation of that solid look like? After completing this Concept, you'll be able to use cross-sections and nets to answer questions like these.

Watch This



MEDIA

Click image to the left for more content.

[Three Dimensions in Two Dimensions CK-12](#)

Guidance

While our world is three dimensional, we are used to modeling and thinking about three dimensional objects on paper (in two dimensions). There are a few common ways to help think about three dimensions in two dimensions. One way to “view” a three-dimensional figure in a two-dimensional plane (like on a piece of paper or a computer screen) is to use cross-sections. Another way to “view” a three-dimensional figure in a two-dimensional plane is to use a net.

Cross-Section: The intersection of a plane with a solid.

The cross-section of the peach plane and the tetrahedron is a *triangle*.

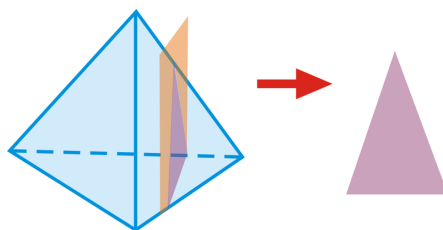

Net: An unfolded, flat representation of the sides of a three-dimensional shape.

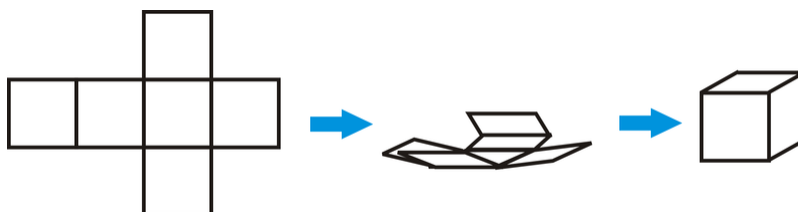

It is good to be able to visualize cross sections and nets as the three dimensional objects they represent.

Example A

What is the shape formed by the intersection of the plane and the regular octahedron?

a)

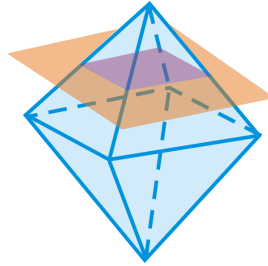

b)

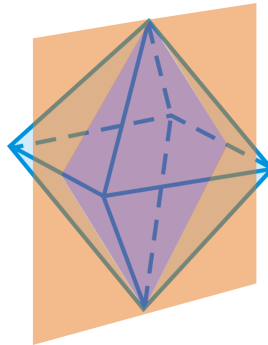

c)

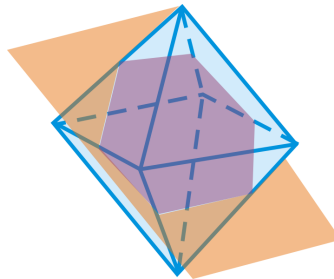

Answer:

- a) Square
- b) Rhombus
- c) Hexagon

Example B

What kind of figure does this net create?

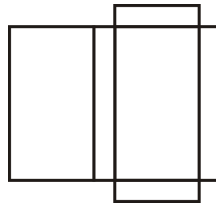

The net creates a rectangular prism.

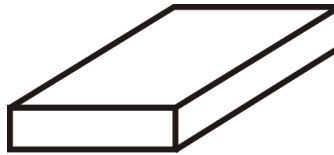

Example C

Draw a net of the right triangular prism below.

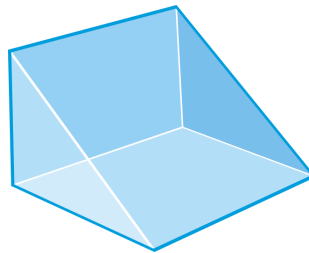

The net will have two triangles and three rectangles. The rectangles are different sizes and the two triangles are the same.

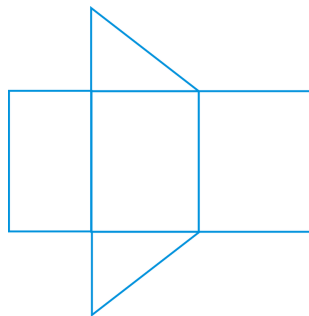

There are several different nets of any polyhedron. For example, this net could have the triangles anywhere along the top or bottom of the three rectangles. Click the site <http://www.cs.mcgill.ca/~sqrt/unfold/unfolding.html> to see a few animations of other nets.



MEDIA

Click image to the left for more content.

Guided Practice

1. Describe the cross section formed by the intersection of the plane and the solid.

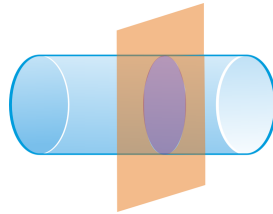

2. Determine what shape is formed by the following net.

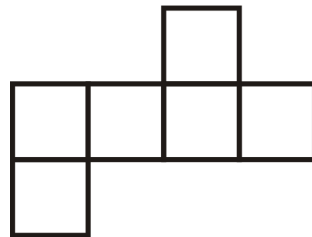

3. Determine what shape is formed by the following net.

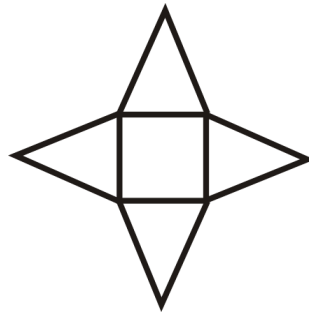
**Answers:**

1. A circle.
2. A cube.
3. A square-based pyramid.

Practice

Describe the cross section formed by the intersection of the plane and the solid.

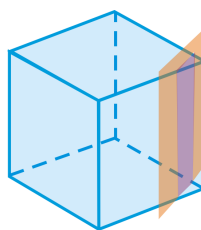

1.

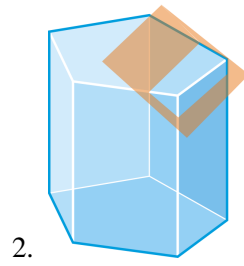

Draw the net for the following solids.

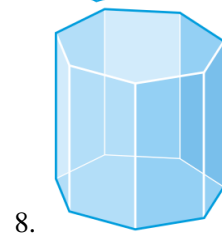
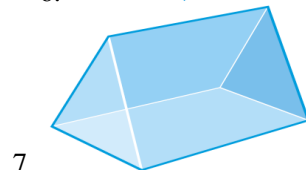
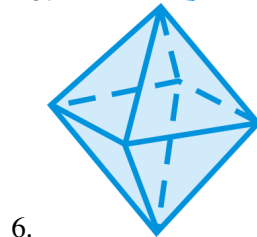
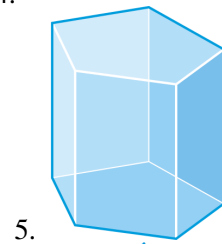
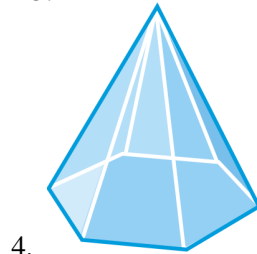
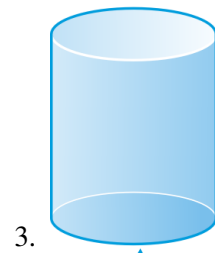

Determine what shape is formed by the following nets.

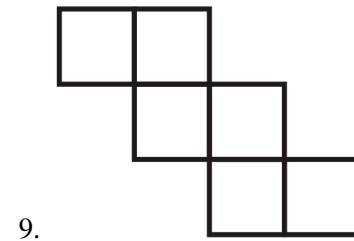

9.

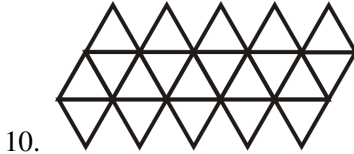

10.

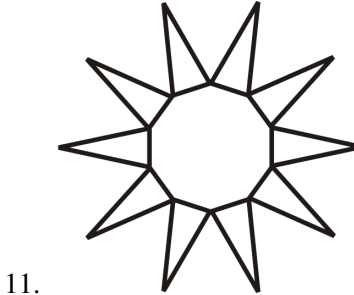

11.

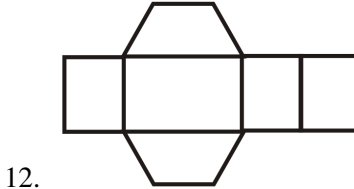

12.

11.3 Prisms

Here you'll learn what a prism is and how to find its volume and surface area.

What if you were given a solid three-dimensional figure with two congruent bases in which the other faces were rectangles? How could you determine how much two-dimensional and three-dimensional space that figure occupies? After completing this Concept, you'll be able to find the surface area and volume of a prism.

Watch This



MEDIA

Click image to the left for more content.

Prisms CK-12

Guidance

A **prism** is a 3-dimensional figure with 2 congruent bases, in parallel planes, in which the other faces are rectangles.

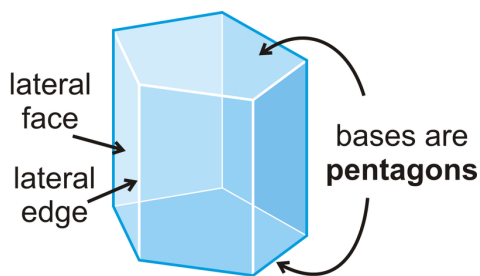

The non-base faces are *lateral faces*. The edges between the lateral faces are *lateral edges*.

This particular example is a **pentagonal prism** because its base is a pentagon. Prisms are named by the shape of their base. Prisms are classified as either **right prisms** (prisms where all the lateral faces are perpendicular to the bases) or **oblique prisms** (prisms that lean to one side, whose base is a parallelogram rather than a rectangle, and whose height is perpendicular to the base's plane), as shown below.

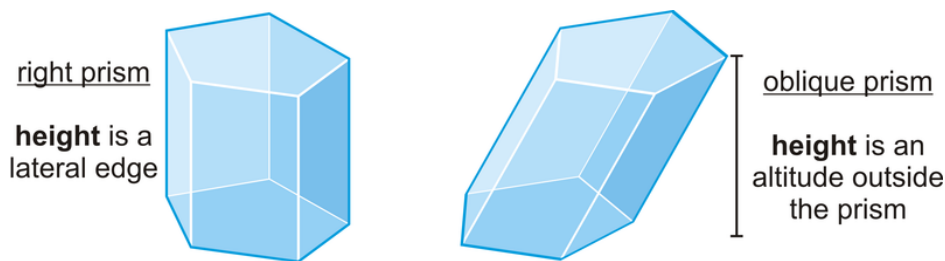

Surface Area

To find the **surface area** of a prism, find the sum of the areas of its faces. The **lateral area** is the sum of the areas of the lateral faces. The basic unit of area is the square unit.

$$\text{Surface Area} = B_1 + B_2 + L_1 + L_2 + L_3$$

$$\text{Lateral Area} = L_1 + L_2 + L_3$$

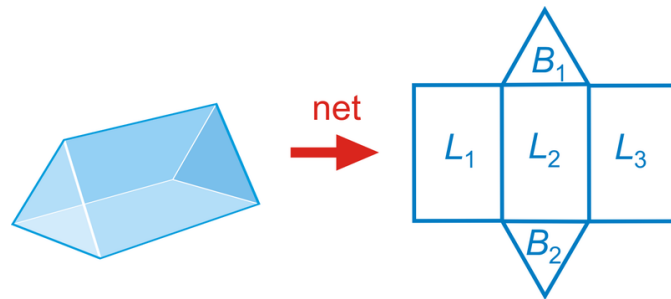

Volume

To find the **volume** of any solid you must figure out how much space it occupies. The basic unit of volume is the cubic unit.

For prisms in particular, to find the volume you must find the area of the base and multiply it by the height.

Volume of a Prism: $V = B \cdot h$, where B = area of base.

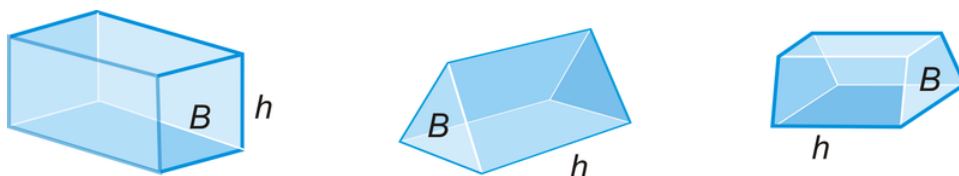

If an oblique prism and a right prism have the same base area and height, then they will have the same volume. This is due to **Cavalieri's Principle**, which states that if two solids have the same height and the same cross-sectional area at every level, then they will have the same volume.

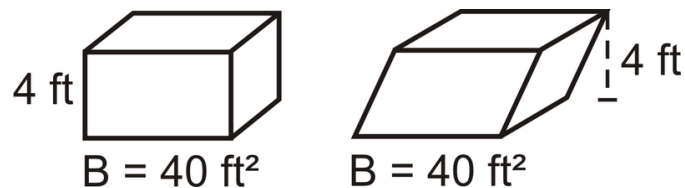

Example A

Find the surface area of the prism below.

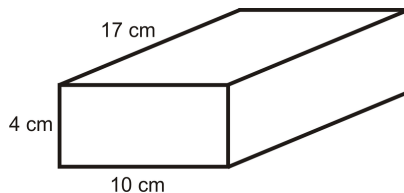

To solve, draw the net of the prism so that we can make sure we find the area of ALL faces.

Using the net, we have:

$$\begin{aligned}
 SA_{prism} &= 2(4)(10) + 2(10)(17) + 2(17)(4) \\
 &= 80 + 340 + 136 \\
 &= 556 \text{ cm}^2
 \end{aligned}$$

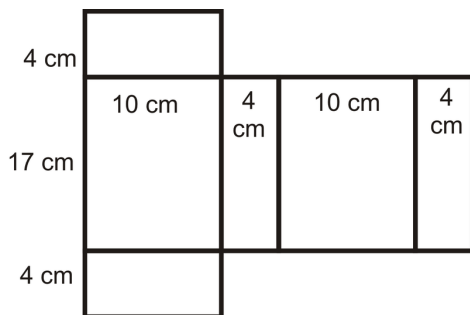

Example B

Find the surface area of the prism below.

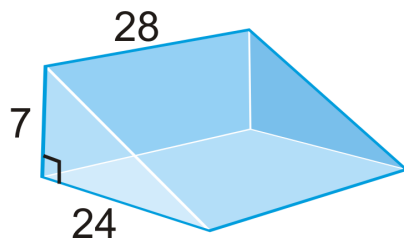

This is a right triangular prism. To find the surface area, we need to find the length of the hypotenuse of the base because it is the width of one of the lateral faces. We can use the Pythagorean Theorem to find this length.

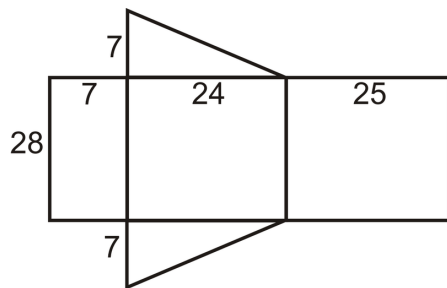

$$\begin{aligned}7^2 + 24^2 &= c^2 \\49 + 576 &= c^2 \\625 &= c^2 \quad c = 25\end{aligned}$$

Looking at the net, the surface area is:

$$\begin{aligned}SA &= 28(7) + 28(24) + 28(25) + 2\left(\frac{1}{2} \cdot 7 \cdot 24\right) \\SA &= 196 + 672 + 700 + 168 = 1736 \text{ units}^2\end{aligned}$$

Example C

You have a small, triangular prism-shaped tent. How much volume does it have once it is set up?

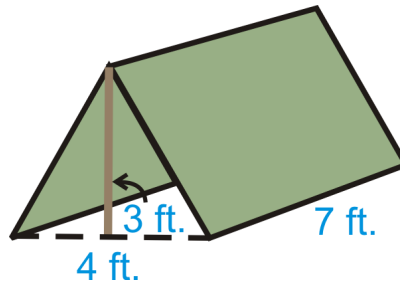

First, we need to find the area of the base.

$$\begin{aligned}B &= \frac{1}{2}(3)(4) = 6 \text{ ft}^2 \\V &= Bh = 6(7) = 42 \text{ ft}^3\end{aligned}$$

Even though the height in this problem does not look like a “height,” it is because it is the perpendicular segment connecting the two bases.



MEDIA

Click image to the left for more content.

Prisms CK-12

Guided Practice

1. The total surface area of the triangular prism is 540 units^2 . What is x ?

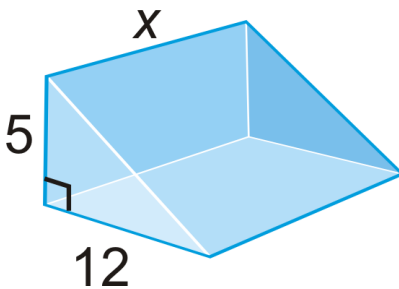

2. Find the volume of the right rectangular prism below.

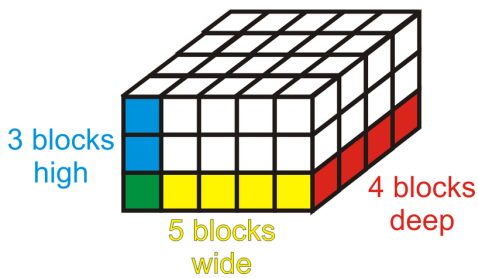

3. A typical shoe box is 8 in by 14 in by 6 in. What is the volume of the box?

Answers:

1. The total surface area is equal to:

$$A_{2 \text{ triangles}} + A_{3 \text{ rectangles}} = 540$$

The hypotenuse of the triangle bases is 13, $\sqrt{5^2 + 12^2}$. Let's fill in what we know.

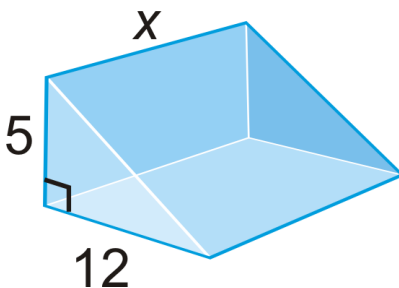

$$A_{2 \text{ triangles}} = 2 \left(\frac{1}{2} \cdot 5 \cdot 12 \right) = 60$$

$$A_{3 \text{ rectangles}} = 5x + 12x + 13x = 30x$$

$$60 + 30x = 540$$

$$30x = 480$$

$$x = 16 \text{ units} \quad \text{The height is 16 units.}$$

2. The area of the base is $(5)(4) = 20$ and the height is 3. So the total volume is $(20)(3) = 60 \text{ units}^3$

3. We can assume that a shoe box is a rectangular prism.

$$V = (8)(14)(6) = 672 \text{ in}^3$$

Interactive Practice

Practice

1. What type of prism is this?

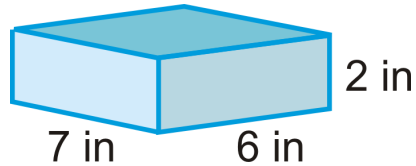

2. Draw the net of this prism.
 3. Find the area of the bases.
 4. Find the area of lateral faces, or the lateral surface area.
 5. Find the total surface area of the prism.
-
6. How many one-inch cubes can fit into a box that is 8 inches wide, 10 inches long, and 12 inches tall? Is this the same as the volume of the box?
 7. A cereal box is 2 inches wide, 10 inches long and 14 inches tall. How much cereal does the box hold?
 8. A can of soda is 4 inches tall and has a diameter of 2 inches. How much soda does the can hold? Round your answer to the nearest hundredth.
 9. A cube holds 216 in^3 . What is the length of each edge?
 10. A cube has sides that are 8 inches. What is the volume?

Use the right triangular prism to answer questions 11-15.

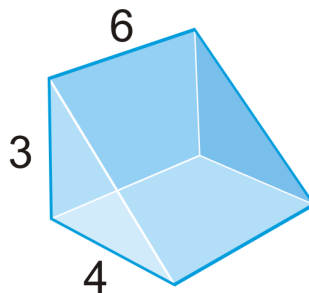

11. Find the volume of the prism.
12. What shape are the bases of this prism? What are their areas?
13. What are the dimensions of each of the lateral faces? What are their areas?
14. Find the lateral surface area of the prism.
15. Find the total surface area of the prism.
16. Describe the difference between *lateral* surface area and *total* surface area.
17. Fuzzy dice are cubes with 4 inch sides.



- a. What is the volume and surface area of one die?
- b. What is the volume and surface area of both dice?

Find the volume of the following solids. Round your answers to the nearest hundredth.

18. bases are isosceles trapezoids

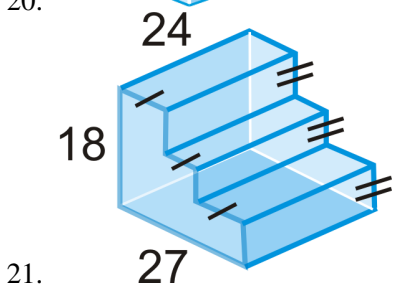
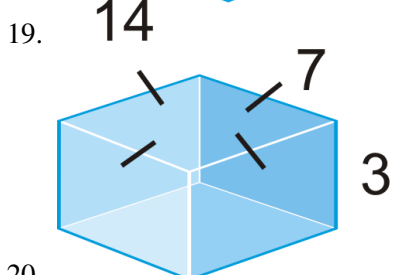
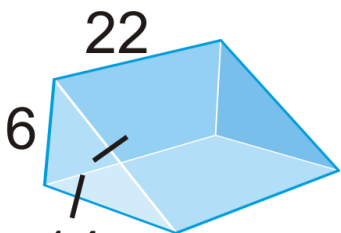
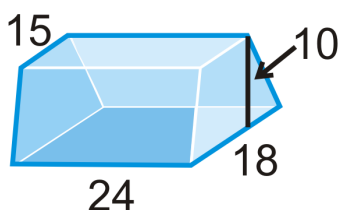

Find the value of x , given the surface area.

22. $V = 504 \text{ units}^3$

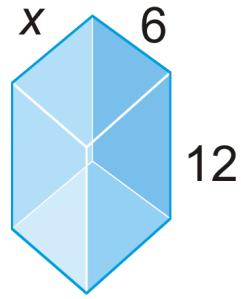

23. $V = 2688 \text{ units}^3$

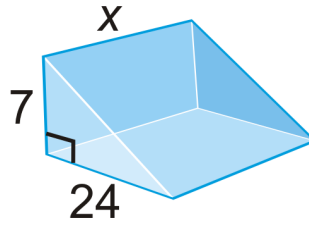

11.4 Cylinders

Here you'll learn what a cylinder is and how to find its volume and surface area.

What if you were given a solid three-dimensional figure with congruent enclosed circular bases that are in parallel planes? How could you determine how much two-dimensional and three-dimensional space that figure occupies? After completing this Concept, you'll be able to find the surface area and volume of a cylinder.

Watch This



MEDIA

Click image to the left for more content.

[Cylinders CK-12](#)

Guidance

A **cylinder** is a solid with congruent circular bases that are in parallel planes. The space between the circles is enclosed.

A cylinder has a *radius* and a *height*.

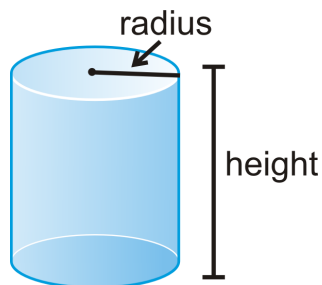

A cylinder can also be *oblique* (slanted) like the one below.

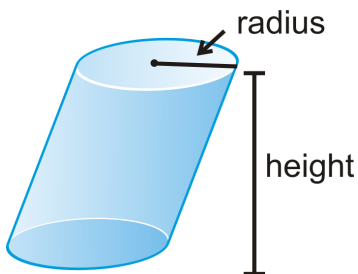

Surface Area

Surface area is the sum of the area of the faces of a solid. The basic unit of area is the square unit.

Surface Area of a Right Cylinder: $SA = 2\pi r^2 + 2\pi rh$.

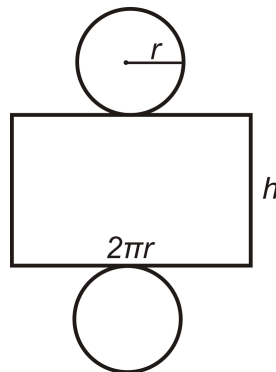

$$\underbrace{2\pi r^2} + \underbrace{2\pi r h}$$

area of length
both of
circles rectangle

To see an animation of the surface area, click <http://www.rkm.com.au/ANIMATIONS/animation-Cylinder-Surface-Area-Derivation.html>, by Russell Knightley.

Volume

To find the **volume** of any solid you must figure out how much space it occupies. The basic unit of volume is the cubic unit. For cylinders, volume is the area of the circular base times the height.

Volume of a Cylinder: $V = \pi r^2 h$.

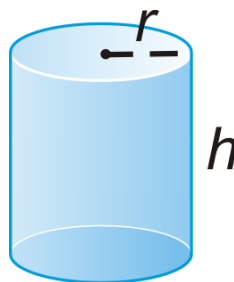

If an oblique cylinder has the same base area and height as another cylinder, then it will have the same volume. This is due to **Cavalieri's Principle**, which states that if two solids have the same height and the same cross-sectional area at every level, then they will have the same volume.

Example A

Find the surface area of the cylinder.

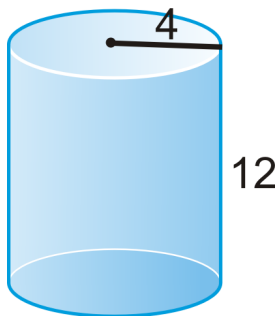

$r = 4$ and $h = 12$.

$$\begin{aligned} SA &= 2\pi(4)^2 + 2\pi(4)(12) \\ &= 32\pi + 96\pi \\ &= 128\pi \text{ units}^2 \end{aligned}$$

Example B

The circumference of the base of a cylinder is 16π and the height is 21. Find the surface area of the cylinder. We need to solve for the radius, using the circumference.

$$\begin{aligned} 2\pi r &= 16\pi \\ r &= 8 \end{aligned}$$

Now, we can find the surface area.

$$\begin{aligned} SA &= 2\pi(8)^2 + (16\pi)(21) \\ &= 128\pi + 336\pi \\ &= 464\pi \text{ units}^2 \end{aligned}$$

Example C

Find the volume of the cylinder.

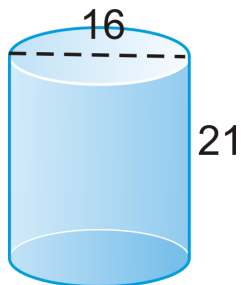

If the diameter is 16, then the radius is 8.

$$V = \pi 8^2(21) = 1344\pi \text{ units}^3$$



MEDIA

Click image to the left for more content.

Cylinders CK-12

Guided Practice

1. Find the volume of the cylinder.

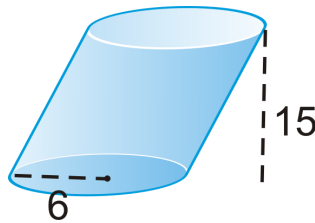

2. If the volume of a cylinder is $484\pi \text{ in}^3$ and the height is 4 in, what is the radius?
3. The circumference of the base of a cylinder is $80\pi \text{ cm}$ and the height is 36 cm. Find the total surface area.

Answers:

1. $V = \pi 6^2(15) = 540\pi \text{ units}^3$
2. Solve for r .

$$484\pi = \pi r^2(4)$$

$$121 = r^2$$

$$11 \text{ in} = r$$

3. We need to solve for the radius, using the circumference.

$$2\pi r = 80\pi$$

$$r = 40$$

Now, we can find the surface area.

$$\begin{aligned} SA &= 2\pi(40)^2 + (80\pi)(36) \\ &= 3200\pi + 2880\pi \\ &= 6080\pi \text{ units}^2 \end{aligned}$$

Practice

1. Two cylinders have the same surface area. Do they have the same volume? How do you know?

2. A cylinder has $r = h$ and the radius is 4 cm. What is the volume?
3. A cylinder has a volume of $486\pi \text{ ft.}^3$. If the height is 6 ft., what is the diameter?
4. A right cylinder has a 7 cm radius and a height of 18 cm. Find the volume.

Find the volume of the following solids. Round your answers to the nearest hundredth.

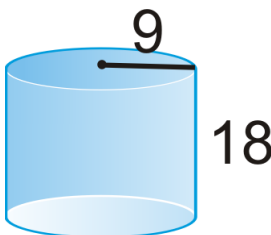

5.

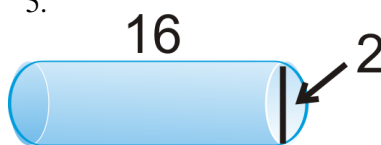

6.

Find the value of x , given the volume.

7. $V = 6144\pi \text{ units}^3$

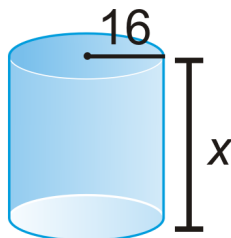

8. The area of the base of a cylinder is $49\pi \text{ in}^2$ and the height is 6 in. Find the volume.
9. The circumference of the base of a cylinder is $34\pi \text{ cm}$ and the height is 20 cm. Find the total surface area.
10. The lateral surface area of a cylinder is $30\pi \text{ m}^2$ and the height is 5m. What is the radius?

11.5 Pyramids

Here you'll learn what a pyramid is and how to find its volume and surface area.

What if you were given a solid three-dimensional figure with one base and lateral faces that meet at a common vertex? How could you determine how much two-dimensional and three-dimensional space that figure occupies? After completing this Concept, you'll be able to find the surface area and volume of a pyramid.

Watch This



MEDIA

Click image to the left for more content.

[PyramidsCK-12](#)

Guidance

A **pyramid** is a solid with one *base* and *lateral faces* that meet at a common *vertex*. The edges between the lateral faces are *lateral edges*. The edges between the base and the lateral faces are *base edges*.

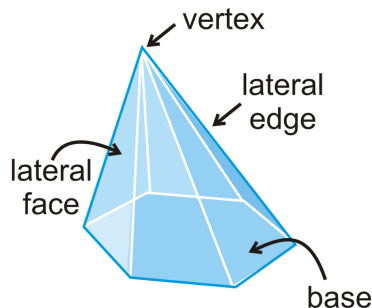

A **regular pyramid** is a pyramid where the base is a regular polygon. All regular pyramids also have a *slant height*, which is the height of a lateral face. A non-regular pyramid does not have a slant height.

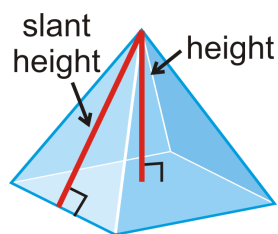

Surface Area

Surface area is a two-dimensional measurement that is the total area of all surfaces that bound a solid. The basic unit of area is the square unit. For pyramids, we will need to use the slant height, which is labeled l , to find the area of each triangular face.

Surface Area of a Regular Pyramid: If B is the area of the base, and n is the number of triangles, then $SA = B + \frac{1}{2}nbl$.

The net shows the surface area of a pyramid. If you ever forget the formula, use the net.

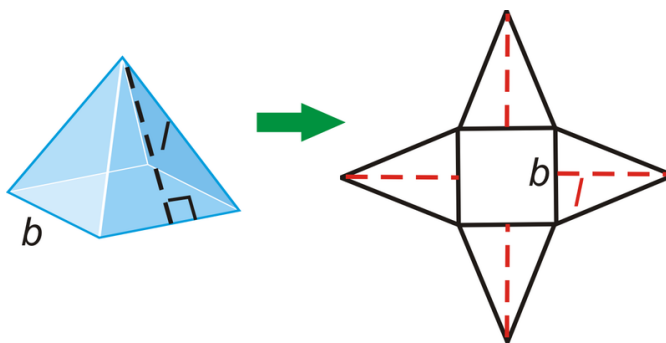

Volume

To find the **volume** of any solid you must figure out how much space it occupies. The basic unit of volume is the cubic unit.

Volume of a Pyramid: $V = \frac{1}{3}Bh$ where B is the area of the base.



Example A

Find the slant height of the square pyramid.

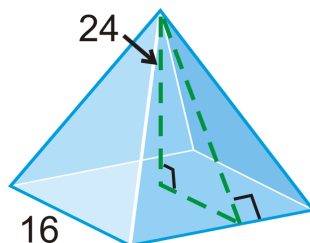

The slant height is the hypotenuse of the right triangle formed by the height and half the base length. Use the Pythagorean Theorem.

$$8^2 + 24^2 = l^2$$

$$640 = l^2$$

$$l = \sqrt{640} = 8\sqrt{10}$$

Example B

Find the surface area of the pyramid from Example A.

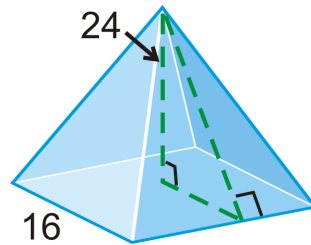

The total surface area of the four triangular faces is $4\left(\frac{1}{2}bl\right) = 2(16)\left(8\sqrt{10}\right) = 256\sqrt{10}$. To find the total surface area, we also need the area of the base, which is $16^2 = 256$. The total surface area is $256\sqrt{10} + 256 \approx 1065.54 \text{ units}^2$.

Example C

Find the volume of the pyramid.

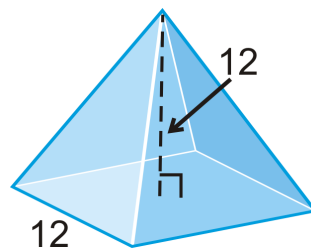

$$V = \frac{1}{3}(12^2)12 = 576 \text{ units}^3$$



MEDIA

Click image to the left for more content.

[PyramidsCK-12](#)

Guided Practice

1. Find the surface area of the *regular* triangular pyramid.

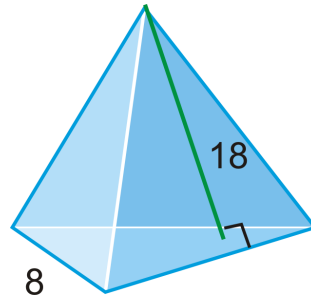

- If the lateral surface area of a regular square pyramid is 72 ft^2 and the base edge is equal to the slant height. What is the length of the base edge?
- Find the height and then volume of the pyramid.

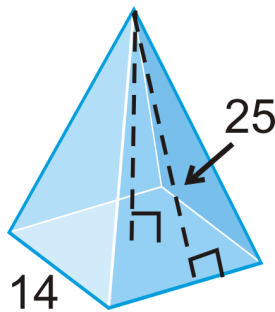

- Find the volume of the pyramid with a right triangle as its base.

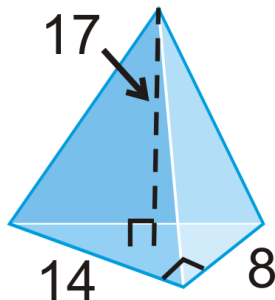

- A rectangular pyramid has a base area of 56 cm^2 and a volume of 224 cm^3 . What is the height of the pyramid?

Answers:

- “Regular” tells us the base is an equilateral triangle. Let’s draw it and find its area.

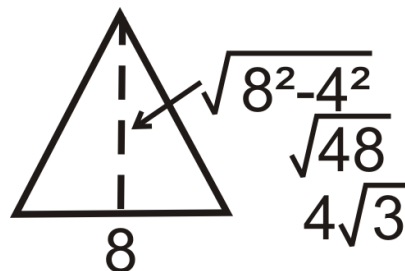

$$B = \frac{1}{2} \cdot 8 \cdot 4\sqrt{3} = 16\sqrt{3}$$

The surface area is:

$$SA = 16\sqrt{3} + \frac{1}{2} \cdot 3 \cdot 8 \cdot 18 = 16\sqrt{3} + 216 \approx 243.71$$

2. In the formula for surface area, the lateral surface area is $\frac{1}{2}nbl$. We know that $n = 4$ and $b = l$. Let's solve for b .

$$\begin{aligned}\frac{1}{2}nbl &= 72 \text{ ft}^2 \\ \frac{1}{2}(4)b^2 &= 72 \\ 2b^2 &= 72 \\ b^2 &= 36 \\ b &= 6 \text{ feet}\end{aligned}$$

3. In this example, we are given the *slant* height. Use the Pythagorean Theorem.

$$\begin{aligned}7^2 + h^2 &= 25^2 \\ h^2 &= 576 \\ h &= 24\end{aligned}$$

$$V = \frac{1}{3}(14^2)(24) = 1568 \text{ units}^3.$$

4. The base of the pyramid is a right triangle. The area of the base is $\frac{1}{2}(14)(8) = 56 \text{ units}^2$.

$$V = \frac{1}{3}(56)(17) \approx 317.33 \text{ units}^3$$

5. Use the formula for volume and plug in the information we were given. Then solve for the height.

$$\begin{aligned}V &= \frac{1}{3}Bh \\ 224 &= \frac{1}{3} \cdot 56h \\ 12 &= h\end{aligned}$$

Practice

Fill in the blanks about the diagram to the left.

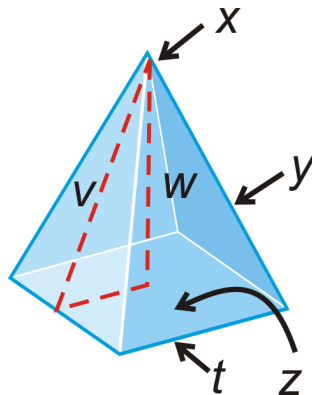

1. x is the _____.
2. The slant height is _____.
3. y is the _____.
4. The height is _____.
5. The base is _____.
6. The base edge is _____.

For questions 7-8, sketch each of the following solids and answer the question. Your drawings should be to scale, but not one-to-one. Leave your answer in simplest radical form.

7. Draw a square pyramid with an edge length of 9 in and a 12 in height. Find the slant height.
8. Draw an equilateral triangle pyramid with an edge length of 6 cm and a height of 6 cm. What is the height of the base?

Find the slant height, l , of one lateral face in each pyramid. Round your answer to the nearest hundredth.

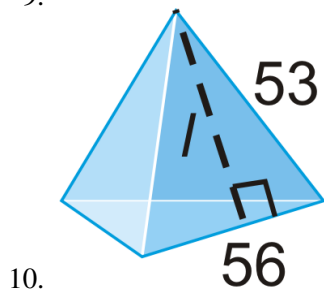
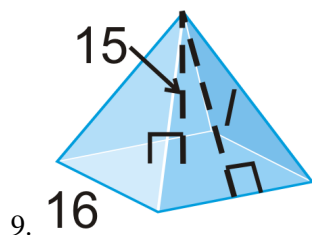

Find the surface area and volume of the regular pyramid. Round your answers to the nearest hundredth.

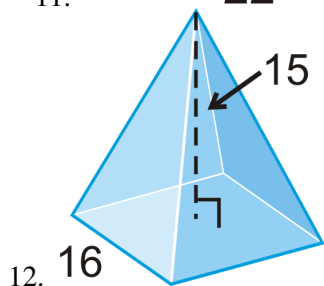
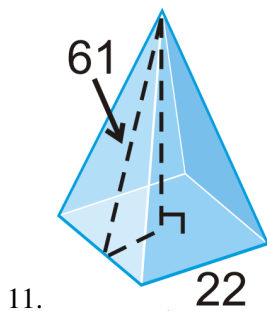

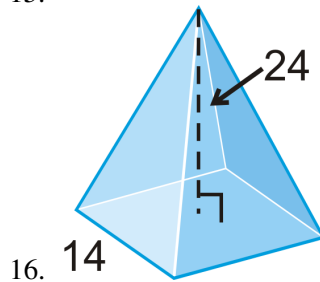
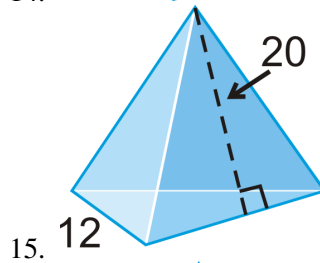
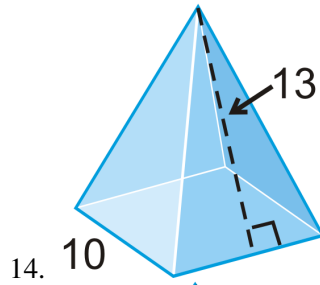
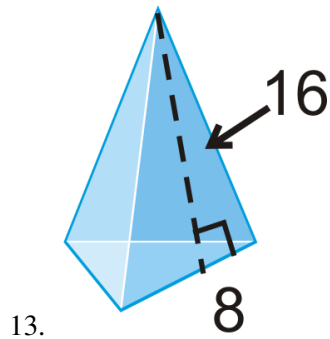

17. A **regular tetrahedron** has four equilateral triangles as its faces.
- Find the height of one of the faces if the edge length is 6 units.
 - Find the area of one face.
 - Find the total surface area of the regular tetrahedron.
18. If the surface area of a square pyramid is 40 ft^2 and the base edge is 4 ft, what is the slant height?
19. If the lateral area of a square pyramid is 800 in^2 and the slant height is 16 in, what is the length of the base edge?
20. If the lateral area of a regular triangle pyramid is 252 in^2 and the base edge is 8 in, what is the slant height?
21. The volume of a square pyramid is 72 square inches and the base edge is 4 inches. What is the height?
22. The volume of a triangle pyramid is 170 in^3 and the base area is 34 in^2 . What is the height of the pyramid?

11.6 Cones

Here you'll learn what a cone is and how to find its volume and surface area.

What if you were given a three-dimensional solid figure with a circular base and sides that taper up towards a vertex? How could you determine how much two-dimensional and three-dimensional space that figure occupies? After completing this Concept, you'll be able to find the surface area and volume of a cone.

Watch This



MEDIA

Click image to the left for more content.

Cones CK-12

Guidance

A **cone** is a solid with a circular base and sides that taper up towards a vertex. A cone is generated from rotating a right triangle, around one leg. A cone has a **slant height**.

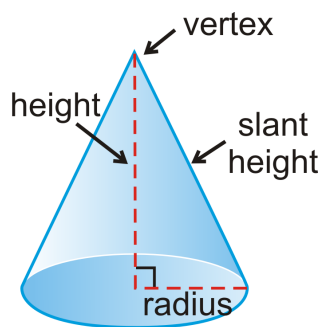

Surface Area

Surface area is a two-dimensional measurement that is the total area of all surfaces that bound a solid. The basic unit of area is the square unit. For the surface area of a cone we need the sum of the area of the base and the area of the sides.

Surface Area of a Right Cone: $SA = \pi r^2 + \pi r l$.

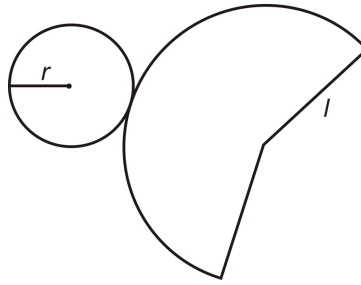

Area of the base: πr^2

Area of the sides: $\pi r l$

Volume

To find the **volume** of any solid you must figure out how much space it occupies. The basic unit of volume is the cubic unit.

Volume of a Cone: $V = \frac{1}{3}\pi r^2 h$.

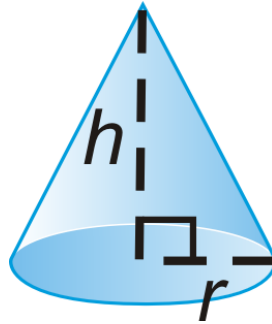

Example A

What is the surface area of the cone?

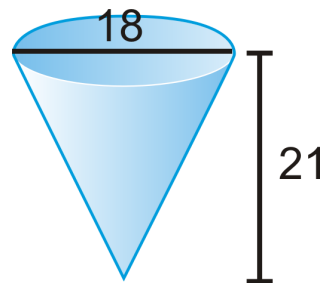

First, we need to find the slant height. Use the Pythagorean Theorem.

$$\begin{aligned} l^2 &= 9^2 + 21^2 \\ &= 81 + 441 \\ l &= \sqrt{522} \approx 22.85 \end{aligned}$$

The total surface area, then, is $SA = \pi 9^2 + \pi(9)(22.85) \approx 900.54 \text{ units}^2$.

Example B

Find the volume of the cone.

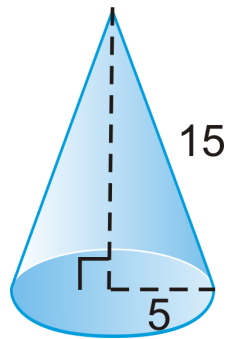

First, we need the height. Use the Pythagorean Theorem.

$$5^2 + h^2 = 15^2$$

$$h = \sqrt{200} = 10\sqrt{2}$$

$$V = \frac{1}{3}(5^2)(10\sqrt{2})\pi \approx 370.24 \text{ units}^3$$

Example C

Find the volume of the cone.

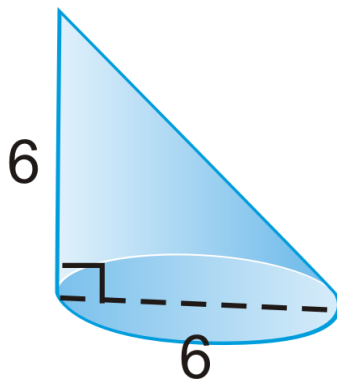

We can use the same volume formula. Find the *radius*.

$$V = \frac{1}{3}\pi(3^2)(6) = 18\pi \approx 56.55 \text{ units}^3$$



MEDIA

Click image to the left for more content.

Guided Practice

1. The surface area of a cone is 36π and the radius is 4 units. What is the slant height?
2. The volume of a cone is $484\pi \text{ cm}^3$ and the height is 12 cm. What is the radius?
3. Find the surface area and volume of the right cone. Round your answers to 2 decimal places.

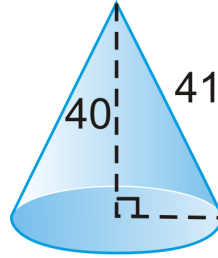
**Answers:**

1. Plug what you know into the formula for the surface area of a cone and solve for l .

$$36\pi = \pi 4^2 + \pi 4l$$

$$36 = 16 + 4l \quad \text{When each term has a } \pi, \text{ they cancel out.}$$

$$20 = 4l$$

$$5 = l$$

2. Plug what you know to the volume formula.

$$484\pi = \frac{1}{3}\pi r^2(12)$$

$$121 = r^2$$

$$11 \text{ cm} = r$$

3. First we need to find the radius. Use the Pythagorean Theorem.

$$r^2 + 40^2 = 41^2$$

$$r^2 = 81$$

$$r = 9$$

Now use the formulas to find surface area and volume. Use the π button on your calculator to help approximate your answer at the end.

$$SA = \pi r^2 + \pi r l$$

$$SA = 81\pi + 369\pi$$

$$SA = 450\pi$$

$$SA = 1413.72$$

Now for volume:

$$V = \frac{1}{3}\pi r^2 h$$

$$V = \frac{1}{3}\pi(9^2)(40)$$

$$V = 1080\pi$$

$$V = 3392.92$$

Practice

Use the cone to fill in the blanks.

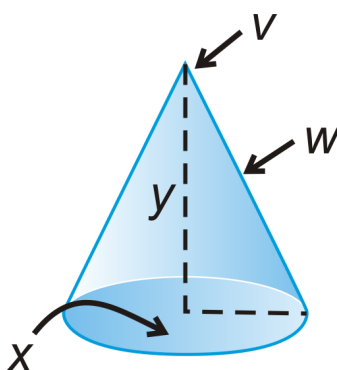

1. v is the _____.
2. The height of the cone is _____.
3. x is a _____ and it is the _____ of the cone.
4. w is the _____.

Sketch the following solid and answer the question. Your drawing should be to scale, but not one-to-one. Leave your answer in simplest radical form.

5. Draw a right cone with a radius of 5 cm and a height of 15 cm. What is the slant height?

Find the slant height, l , of one lateral face in the cone. Round your answer to the nearest hundredth.

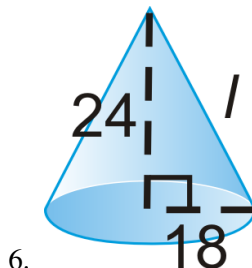

6.

Find the surface area and volume of the right cones. Round your answers to 2 decimal places.

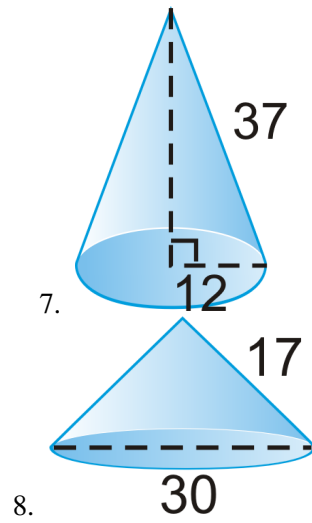

- 7.
- 8.
9. If the lateral surface area of a cone is $30\pi \text{ cm}^2$ and the radius is 5 cm, what is the slant height?
10. If the surface area of a cone is $105\pi \text{ cm}^2$ and the slant height is 8 cm, what is the radius?
11. If the volume of a cone is $30\pi \text{ cm}^3$ and the radius is 5 cm, what is the height?
12. If the volume of a cone is $105\pi \text{ cm}^3$ and the height is 35 cm, what is the radius?

11.7 Spheres

Here you'll learn what a sphere is and how to find its volume and surface area.

What if you were given a solid figure consisting of the set of all points, in three-dimensional space, that are equidistant from a point? How could you determine how much two-dimensional and three-dimensional space that figure occupies? After completing this Concept, you'll be able to find the surface area and volume of a sphere.

Watch This



MEDIA

Click image to the left for more content.

Spheres CK-12

Guidance

A **sphere** is the set of all points, in three-dimensional space, which are equidistant from a point. The **radius** has one endpoint on the sphere and the other endpoint at the center of that sphere. The **diameter** of a sphere must contain the center.

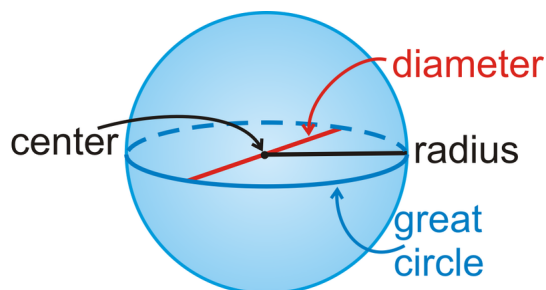

A great circle is the largest circular cross-section in a sphere. *The circumference of a sphere is the circumference of a great circle.* Every great circle divides a sphere into two congruent **hemispheres**.

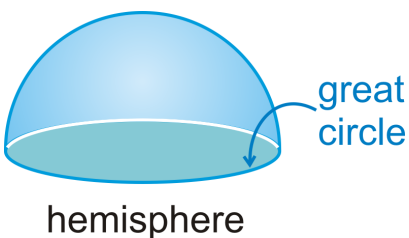

Surface Area

Surface area is a two-dimensional measurement that is the total area of all surfaces that bound a solid. The basic unit of area is the square unit. The best way to understand the surface area of a sphere is to watch the link by Russell Knightley, <http://www.rkm.com.au/ANIMATIONS/animation-Sphere-Surface-Area-Derivation.html>

Surface Area of a Sphere: $SA = 4\pi r^2$.

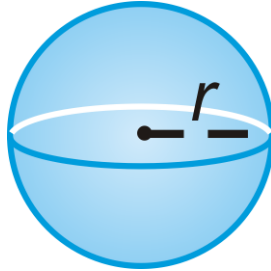
**Volume**

To find the **volume** of any solid you must figure out how much space it occupies. The basic unit of volume is the cubic unit. To see an animation of the volume of a sphere, see <http://www.rkm.com.au/ANIMATIONS/animation-Sphere-Volume-Derivation.html> by Russell Knightley.

Volume of a Sphere: $V = \frac{4}{3}\pi r^3$.

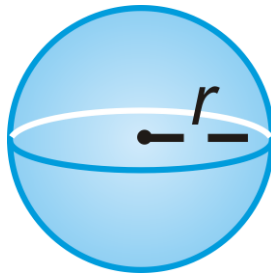
**Example A**

The circumference of a sphere is 26π feet. What is the radius of the sphere?

The circumference is referring to the circumference of a great circle. Use $C = 2\pi r$.

$$\begin{aligned} 2\pi r &= 26\pi \\ r &= 13 \text{ ft.} \end{aligned}$$

Example B

Find the surface area of a sphere with a radius of 14 feet.

Use the formula.

$$\begin{aligned} SA &= 4\pi(14)^2 \\ &= 784\pi \text{ ft}^2 \end{aligned}$$

Example C

Find the volume of a sphere with a radius of 6 m.

Use the formula for volume:

$$\begin{aligned} V &= \frac{4}{3}\pi 6^3 \\ &= \frac{4}{3}\pi(216) \\ &= 288\pi \text{ m}^3 \end{aligned}$$

**MEDIA**

Click image to the left for more content.

Spheres CK-12

Guided Practice

1. Find the surface area of the figure below, a hemisphere with a circular base added.

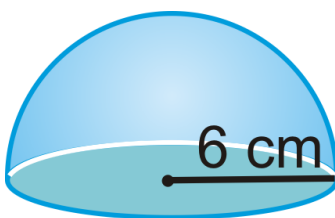

2. The surface area of a sphere is $100\pi \text{ in}^2$. What is the radius?
3. A sphere has a volume of $14,137.167 \text{ ft}^3$. What is the radius?

Answers:

1. Use the formula for surface area.

$$\begin{aligned} SA &= \pi r^2 + \frac{1}{2}4\pi r^2 \\ &= \pi(6^2) + 2\pi(6^2) \\ &= 36\pi + 72\pi = 108\pi \text{ cm}^2 \end{aligned}$$

2. Use the formula for surface area.

$$\begin{aligned}
 SA &= 4\pi r^2 \\
 100\pi &= 4\pi r^2 \\
 25 &= r^2 \\
 5 &= r
 \end{aligned}$$

3. Use the formula for volume, plug in the given volume and solve for the radius, r .

$$\begin{aligned}
 V &= \frac{4}{3}\pi r^3 \\
 14,137.167 &= \frac{4}{3}\pi r^3 \\
 \frac{3}{4\pi} \cdot 14,137.167 &= r^3 \\
 3375 &\approx r^3
 \end{aligned}$$

At this point, you will need to take the **cubed root** of 3375. Your calculator might have a button that looks like $\sqrt[3]{}$, or you can do $3375^{\frac{1}{3}}$.

$$\sqrt[3]{3375} = 15 \approx r$$

Practice

1. Are there any cross-sections of a sphere that are not a circle? Explain your answer.
2. List all the parts of a sphere that are the **same** as a circle.
3. List any parts of a sphere that a circle does not have.

Find the surface area and volume of a sphere with: (Leave your answer in terms of π)

4. a radius of 8 in.
5. a diameter of 18 cm.
6. a radius of 20 ft.
7. a diameter of 4 m.
8. a radius of 15 ft.
9. a diameter of 32 in.
10. a circumference of 26π cm.
11. a circumference of 50π yds.
12. The surface area of a sphere is 121π in². What is the radius?
13. The volume of a sphere is 47916π m³. What is the radius?
14. The surface area of a sphere is 4π ft². What is the volume?
15. The volume of a sphere is 36π mi³. What is the surface area?
16. Find the radius of the sphere that has a volume of 335 cm³. Round your answer to the nearest hundredth.
17. Find the radius of the sphere that has a surface area 225π ft².

Find the surface area and volume of the following shape. Leave your answers in terms of π .

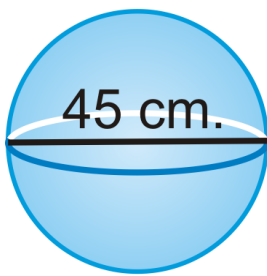

18.

11.8 Composite Solids

Here you'll learn what a composite solid is and how to find its volume and surface area.

What if you built a solid three-dimensional house model consisting of a pyramid on top of a square prism? How could you determine how much two-dimensional and three-dimensional space that model occupies? After completing this Concept, you'll be able to find the surface area and volume of composite solids like this one.

Watch This



MEDIA

Click image to the left for more content.

Composite SolidsCK-12

Guidance

A **composite solid** is a solid that is composed, or made up of, two or more solids. The solids that it is made up of are generally prisms, pyramids, cones, cylinders, and spheres. In order to find the surface area and volume of a composite solid, you need to know how to find the surface area and volume of prisms, pyramids, cones, cylinders, and spheres. For more information on any of those specific solids, consult the concept that focuses on them. This concept will assume knowledge of those five solids.

Most composite solids problems that you will see will be about volume, so most of the examples and practice problems below are about volume. There is one surface area example as well.

Example A

Find the volume of the solid below.

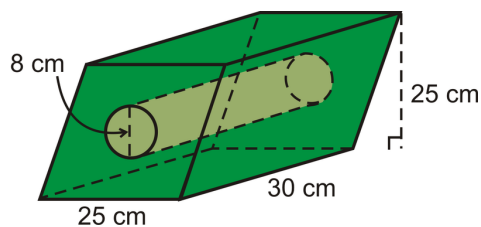

This solid is a parallelogram-based prism with a cylinder cut out of the middle.

$$V_{prism} = (25 \cdot 25)30 = 18,750 \text{ cm}^3$$

$$V_{cylinder} = \pi(4)^2(30) = 480\pi \text{ cm}^3$$

The total volume is $18750 - 480\pi \approx 17,242.04 \text{ cm}^3$.

Example B

Find the volume of the composite solid. All bases are squares.

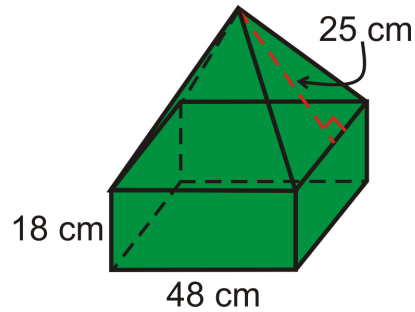

This is a square prism with a square pyramid on top. First, we need the height of the pyramid portion. Using the Pythagorean Theorem, we have, $h = \sqrt{25^2 - 24^2} = 7$.

$$V_{prism} = (48)(48)(18) = 41,472 \text{ cm}^3$$

$$V_{pyramid} = \frac{1}{3}(48^2)(7) = 5376 \text{ cm}^3$$

The total volume is $41,472 + 5376 = 46,848 \text{ cm}^3$.

Example C

Find the surface area of the following solid.

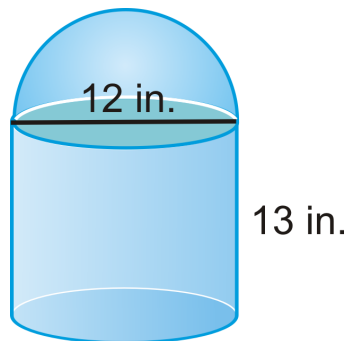

This solid is a cylinder with a hemisphere on top. It is one solid, so do not include the bottom of the hemisphere or the top of the cylinder.

$$\begin{aligned} SA &= LA_{cylinder} + LA_{hemisphere} + A_{base\ circle} \\ &= 2\pi rh + \frac{1}{2}4\pi r^2 + \pi r^2 \\ &= 2\pi(6)(13) + 2\pi 6^2 + \pi 6^2 \\ &= 156\pi + 72\pi + 36\pi \\ &= 264\pi \text{ in}^2 \end{aligned}$$

“LA” stands for *lateral area*.



MEDIA

 Click image to the left for more content.

Composite SolidsCK-12

Guided Practice

1. Find the volume of the following solid.

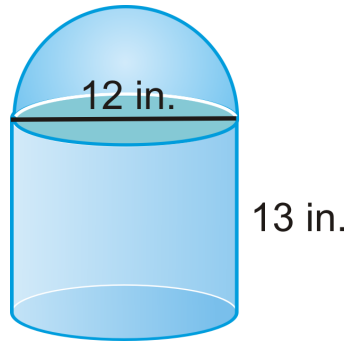

2. Find the volume of the base prism. Round your answer to the nearest hundredth.

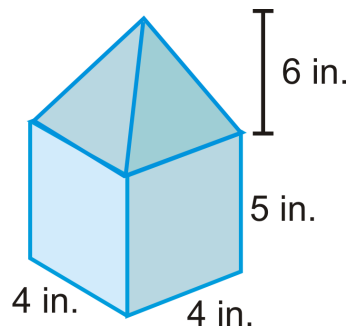

3. Using your work from #2, find the volume of the pyramid and then of the entire solid.

Answers:

1. Use what you know about cylinders and spheres. The top of the solid is a hemisphere.

$$V_{cylinder} = \pi 6^2 (13) = 468\pi$$

$$V_{hemisphere} = \frac{1}{2} \left(\frac{4}{3} \pi 6^3 \right) = 144\pi$$

$$V_{total} = 468\pi + 144\pi = 612\pi \text{ in}^3$$

2. Use what you know about prisms.

$$V_{prism} = B \cdot h$$

$$V_{prism} = (4 \cdot 4) \cdot 5$$

$$V_{prism} = 80 \text{ in}^3$$

3. Use what you know about pyramids.

$$V_{\text{pyramid}} = \frac{1}{3}B \cdot h$$

$$V_{\text{pyramid}} = \frac{1}{3}(4 \cdot 4)(6)$$

$$V_{\text{pyramid}} = 32\text{in}^3$$

Now find the total volume by finding the sum of the volumes of each solid.

$$V_{\text{total}} = V_{\text{prism}} + V_{\text{pyramid}}$$

$$V_{\text{total}} = 112\text{in}^3$$

Practice

Round your answers to the nearest hundredth. The solid below is a cube with a cone cut out.

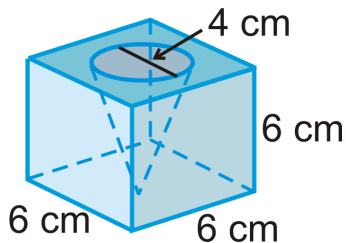

1. Find the volume of the cube.
2. Find the volume of the cone.
3. Find the volume of the entire solid.

The solid below is a cylinder with a cone on top.

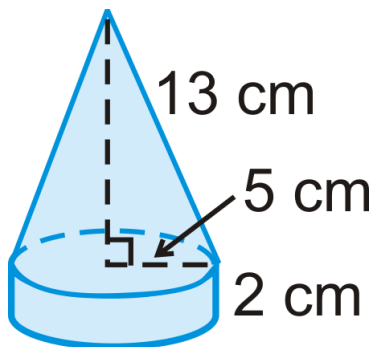

4. Find the volume of the cylinder.
5. Find the volume of the cone.
6. Find the volume of the entire solid.

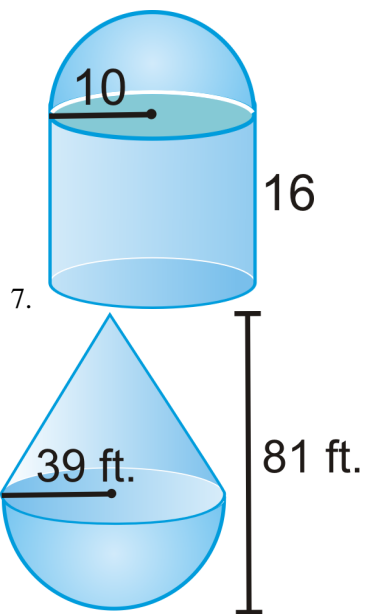

9. You may assume the bottom is *open*.

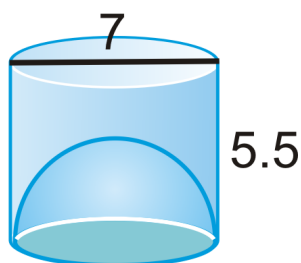

Find the volume of the following shapes. Round your answers to the nearest hundredth.

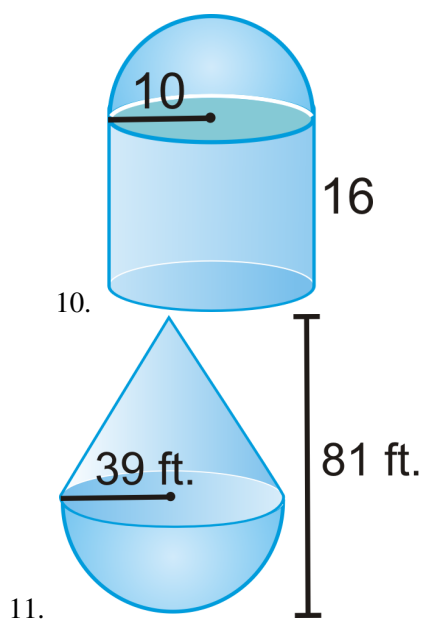

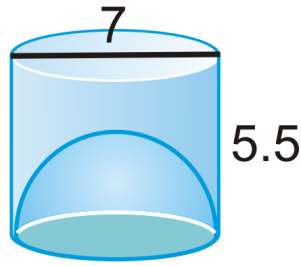

12.

13. A sphere has a radius of 5 cm. A right cylinder has the same radius and volume. Find the height of the cylinder.

The bases of the prism are squares and a cylinder is cut out of the center.

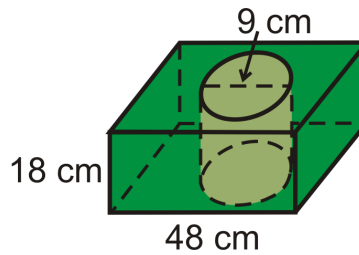

14. Find the volume of the prism.
 15. Find the volume of the cylinder in the center.
 16. Find the volume of the figure.

This is a prism with half a cylinder on the top.

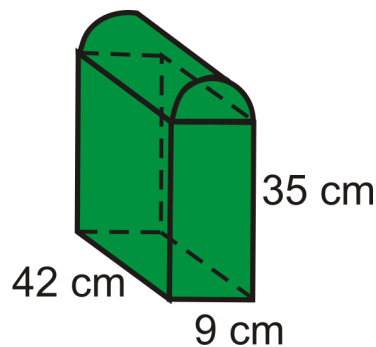

17. Find the volume of the prism.
 18. Find the volume of the half-cylinder.
 19. Find the volume of the entire figure.

Tennis balls with a 3 inch diameter are sold in cans of three. The can is a cylinder. Round your answers to the nearest hundredth.



20. What is the volume of one tennis ball?
21. What is the volume of the cylinder?
22. Assume the balls touch the can on the sides, top and bottom. What is the volume of the space *not* occupied by the tennis balls?

11.9 Area and Volume of Similar Solids

Here you'll learn that the ratio of the surface areas of similar solids is equal to the square of their scale factor and that the ratio of their volumes is equal to the cube of their scale factor.

What if you were given two similar square prisms and told what the scale factor of their sides was? How could you find the ratio of their surface areas and the ratio of their volumes? After completing this Concept, you'll be able to use the Surface Area Ratio and the Volume Ratio to solve problems like this.

Watch This



MEDIA

Click image to the left for more content.

[Similar Solids CK-12](#)

Guidance

Two shapes are similar if all their corresponding angles are congruent and all their corresponding sides are proportional. **Two solids are similar** if they are the same type of solid and their corresponding radii, heights, base lengths, widths, etc. are proportional.

Surface Areas of Similar Solids

In two dimensions, when two shapes are similar, the ratio of their areas is the square of the scale factor. This relationship holds in three dimensions as well.

Surface Area Ratio: If two solids are similar with a scale factor of $\frac{a}{b}$, then the surface areas are in a ratio of $\left(\frac{a}{b}\right)^2$.

Volumes of Similar Solids

Just like surface area, volumes of similar solids have a relationship that is related to the scale factor.

Volume Ratio: If two solids are similar with a scale factor of $\frac{a}{b}$, then the volumes are in a ratio of $\left(\frac{a}{b}\right)^3$.

Summary

TABLE 11.2:

	<i>Ratios</i>	<i>Units</i>
<i>Scale Factor</i>	$\frac{a}{b}$	in, ft, cm, m, etc.
<i>Ratio of the Surface Areas</i>	$\left(\frac{a}{b}\right)^2$	in^2, ft^2, cm^2, m^2 , etc.
<i>Ratio of the Volumes</i>	$\left(\frac{a}{b}\right)^3$	in^3, ft^3, cm^3, m^3 , etc.

Example A

Are the two rectangular prisms similar? How do you know?

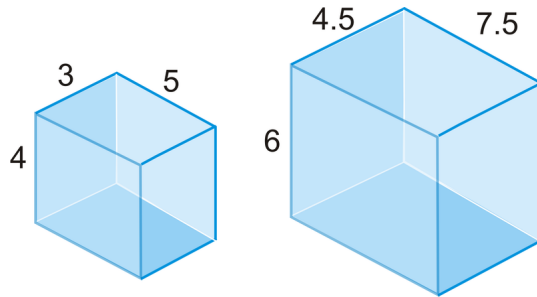

Match up the corresponding heights, widths, and lengths.

$$\frac{\text{small prism}}{\text{large prism}} : \frac{3}{4.5} = \frac{4}{6} = \frac{5}{7.5}$$

The congruent ratios tell us the two prisms are similar.

Example B

Two similar cylinders are below. If the ratio of the areas is 16:25, what is the height of the taller cylinder?

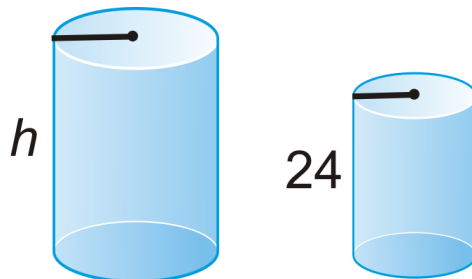

First, we need to take the square root of the area ratio to find the scale factor, $\sqrt{\frac{16}{25}} = \frac{4}{5}$. Set up a proportion to find h .

$$\begin{aligned} \frac{4}{5} &= \frac{24}{h} \\ 4h &= 120 \\ h &= 30 \text{ units} \end{aligned}$$

Example C

Two spheres have radii in a ratio of 3:4. What is the ratio of their volumes?

If we cube 3 and 4, we will have the ratio of the volumes. $3^3 : 4^3 = 27 : 64$.



MEDIA

Click image to the left for more content.

Similar Solids CK-12

Guided Practice

1. Determine if the two triangular pyramids are similar.

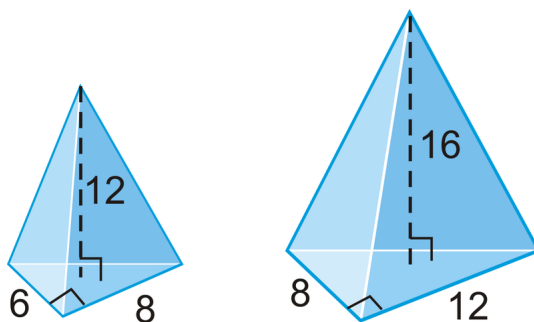

2. Using the cylinders from Example B, if the area of the smaller cylinder is $1536\pi \text{ cm}^2$, what is the area of the larger cylinder?
3. If the ratio of the volumes of two similar prisms is 125:8, what is the scale factor?
4. Two similar triangular prisms are below. If the ratio of the volumes is 343:125, find the missing sides in both triangles.

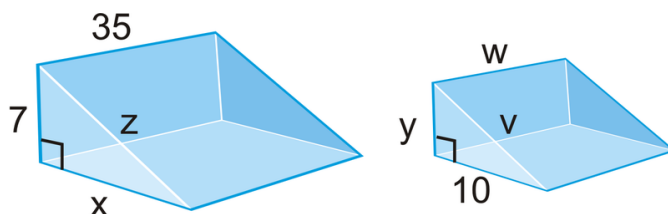

Answers:

1. Match up the corresponding parts.

$$\frac{6}{8} = \frac{3}{4} = \frac{12}{16} \text{ however, } \frac{8}{12} = \frac{2}{3}.$$

These triangle pyramids are not similar.

2. Set up a proportion using the ratio of the areas, 16:25.

$$\begin{aligned} \frac{16}{25} &= \frac{1536\pi}{A} \\ 16A &= 38,400\pi \\ A &= 2400\pi \text{ cm}^2 \end{aligned}$$

3. Take the **cube root** of 125 and 8 to find the scale factor.

$$\sqrt[3]{125} : \sqrt[3]{8} = 5 : 2$$

4. The scale factor is 7:5, the cube root of 343:125. With the scale factor, we can now set up several proportions.

$$\frac{7}{5} = \frac{7}{y}$$

$$y = 5$$

$$\frac{7}{5} = \frac{x}{10}$$

$$x = 14$$

$$\frac{7}{5} = \frac{35}{w}$$

$$w = 25$$

$$7^2 + x^2 = z^2$$

$$7^2 + 14^2 = z^2$$

$$z = \sqrt{245} = 7\sqrt{5}$$

$$\frac{7}{5} = \frac{z}{v}$$

$$\frac{7}{5} = \frac{7\sqrt{5}}{v} \rightarrow v = 5\sqrt{5}$$

Practice

Determine if each pair of right solids are similar.

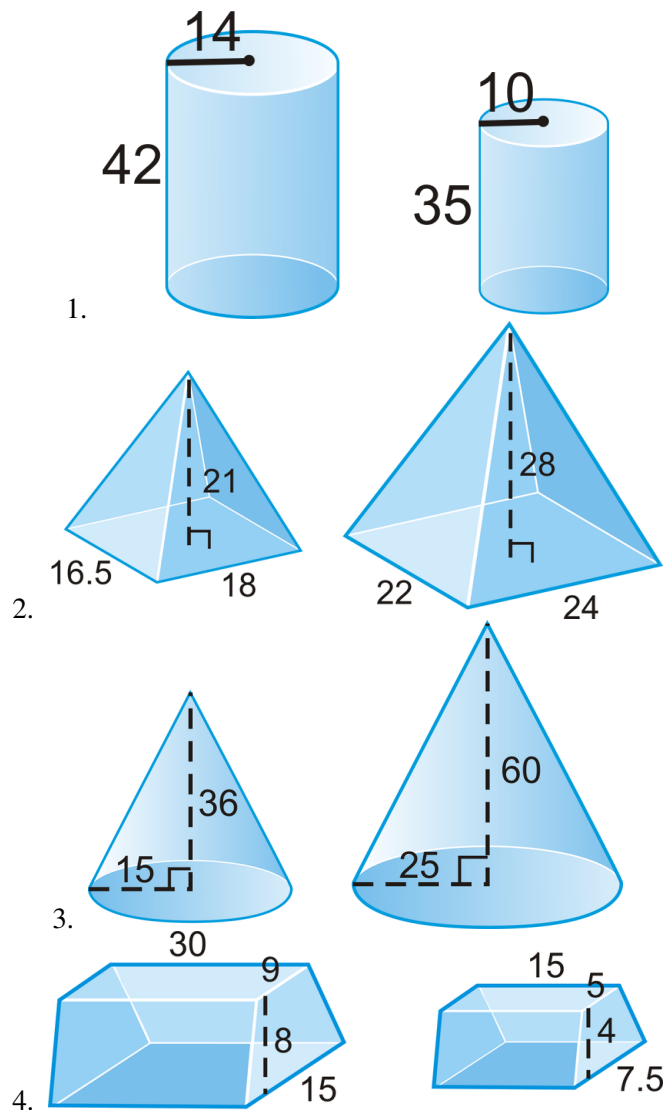

- Are all cubes similar? Why or why not?
- Two prisms have a scale factor of 1:4. What is the ratio of their surface areas?
- Two pyramids have a scale factor of 2:7. What is the ratio of their volumes?
- Two spheres have radii of 5 and 9. What is the ratio of their volumes?
- The surface area of two similar cones is in a ratio of 64:121. What is the scale factor?
- The volume of two hemispheres is in a ratio of 125:1728. What is the scale factor?

- A cone has a volume of 15π and is similar to another larger cone. If the scale factor is 5:9, what is the volume of the larger cone?
- The ratio of the volumes of two similar pyramids is 8:27. What is the ratio of their total surface areas?
- The ratio of the volumes of two tetrahedrons is 1000:1. The smaller tetrahedron has a side of length 6 cm. What is the side length of the larger tetrahedron?
- The ratio of the surface areas of two cubes is 64:225. What is the ratio of the volumes?

Below are two similar square pyramids with a volume ratio of 8:27. The base lengths are equal to the heights. Use this to answer questions 15-18.

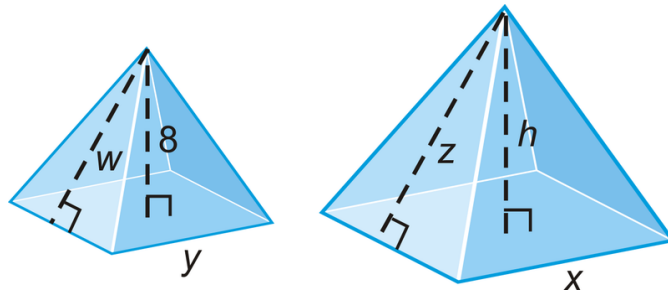

- What is the scale factor?
- What is the ratio of the surface areas?
- Find h, x and y .
- Find the volume of both pyramids.

Use the hemispheres below to answer questions 19-20.

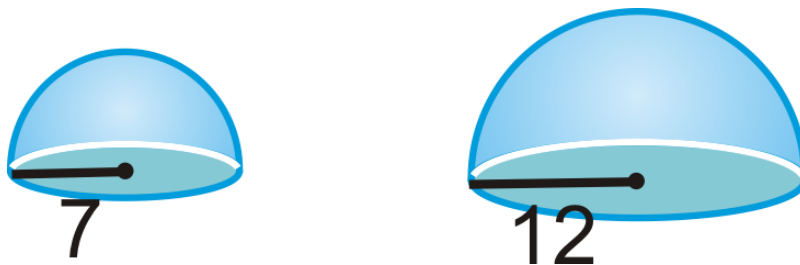

- Are the two hemispheres similar? How do you know?
 - Find the ratio of the surface areas and volumes.
- The ratio of the surface areas of two similar cylinders is 16:81. What is the ratio of the volumes?

Summary

This chapter presents three-dimensional geometric figures beginning with polyhedrons, regular polyhedrons, and an explanation of Euler's Theorem. Three-dimensional figures represented as cross sections and nets are discussed. Then the chapter branches out to the formulas for surface area and volume of prisms, cylinders, pyramids, cones, spheres and composite solids. The relationship between similar solids and their surface areas and volumes are explored.

Rigid Transformations

Chapter Outline

- 12.1 REFLECTION SYMMETRY
 - 12.2 ROTATION SYMMETRY
 - 12.3 GEOMETRIC TRANSLATIONS
 - 12.4 ROTATIONS
 - 12.5 REFLECTIONS
 - 12.6 COMPOSITION OF TRANSFORMATIONS
 - 12.7 TESSELLATIONS
-

Introduction

The final chapter of Geometry transforms a figure by moving, flipping, or rotating it. First, we will look at symmetry, followed by the different transformations.

12.1 Reflection Symmetry

Here you'll learn what reflection symmetry is and how to find lines of symmetry for a figure.

What if you had a six-pointed star, you drew a line down it, and then you folded it along that line? If the two sides of the star lined up, what would that mean about the line? After completing this Concept, you'll be able to draw the lines of symmetry for a figure like this one.

Watch This



MEDIA

Click image to the left for more content.

Reflection Symmetry CK-12

Guidance

A **line of symmetry** is a line that passes through a figure such that it splits the figure into two congruent halves such that if one half were folded across the line of symmetry it would land directly on top of the other half.

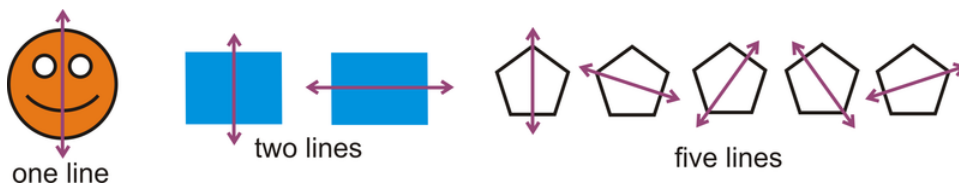

Reflection symmetry is present when a figure has one or more lines of symmetry. These figures have reflection symmetry:



These figures do not have reflection symmetry:



Example A

Find all lines of symmetry for the shape below.

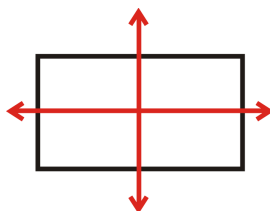

This figure has two lines of symmetry.

**Example B**

Does the figure below have reflection symmetry?



Yes, this figure has reflection symmetry.

**Example C**

Does the figure below have reflection symmetry?



Yes, this figure has reflection symmetry.

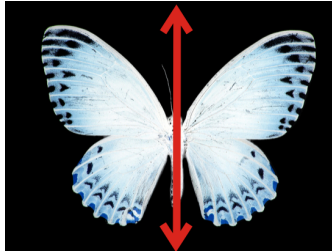

MEDIA

Click image to the left for more content.

Reflection Symmetry CK-12

Guided Practice

Find all lines of symmetry for the shapes below.

1.

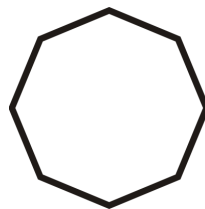

2.



3.

**Answers:**

For each figure, draw lines through the figure so that the lines perfectly cut the figure in half. Figure 1 has eight, 2 has no lines of symmetry, and 3 has one.

1.

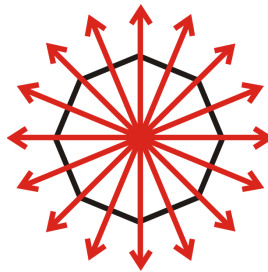

2.



3.

**Practice**

Determine whether each statement is true or false.

1. All right triangles have line symmetry.
2. All isosceles triangles have line symmetry.
3. Every rectangle has line symmetry.
4. Every rectangle has exactly two lines of symmetry.
5. Every parallelogram has line symmetry.
6. Every square has exactly two lines of symmetry.
7. Every regular polygon has three lines of symmetry.
8. Every sector of a circle has a line of symmetry.

Draw the following figures.

9. A quadrilateral that has two pairs of congruent sides and exactly one line of symmetry.

10. A figure with infinitely many lines of symmetry.

Find all lines of symmetry for the letters below.

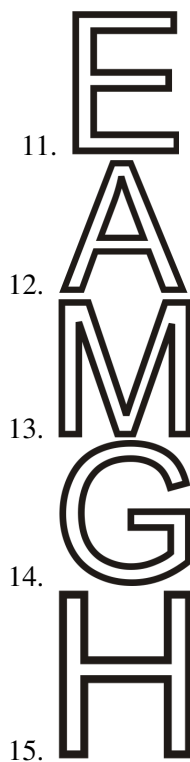

Determine if the words below have reflection symmetry.

16. **OHIO**
17. **MOW**
18. **WOW**
19. **KICK**
20. **pod**

Trace each figure and then draw in all lines of symmetry.

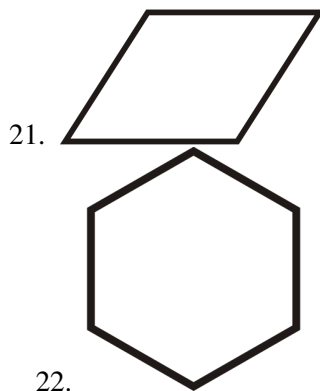

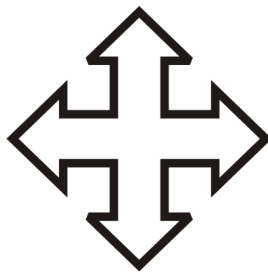

23.

Determine if the figures below have reflection symmetry. Identify all lines of symmetry.

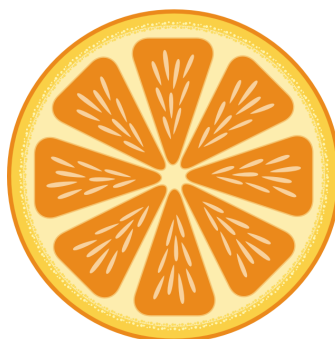

24.

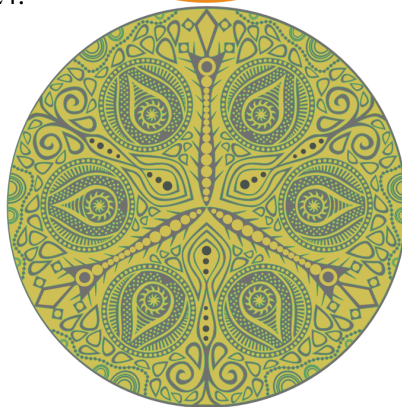

25.



26.

12.2 Rotation Symmetry

Here you'll learn what rotational symmetry is and how to find the angle of rotation for a figure.

What if you had a six-pointed star and you rotated that star less than 360° ? If the rotated star looked exactly the same as the original star, what would that say about the star? After completing this Concept, you'll be able to determine if a figure like this one has rotational symmetry.

Watch This



MEDIA

Click image to the left for more content.

[RotationSymmetry CK-12](#)

Guidance

Rotational symmetry is present when a figure can be rotated (less than 360°) such that it looks like it did before the rotation. The **center of rotation** is the point a figure is rotated around such that the rotational symmetry holds.

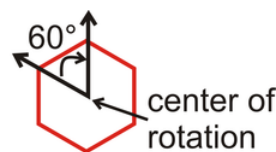
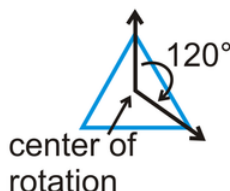

For the H , we can rotate it twice, the triangle can be rotated 3 times and still look the same and the hexagon can be rotated 6 times.

Example A

Determine if the figure below has rotational symmetry. Find the angle and how many times it can be rotated.

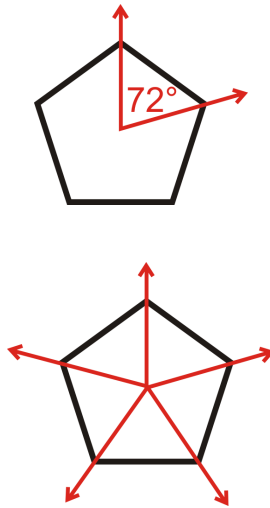

The pentagon can be rotated 5 times. Because there are 5 lines of rotational symmetry, the angle would be $\frac{360^\circ}{5} = 72^\circ$.

**Example B**

Determine if the figure below has rotational symmetry. Find the angle and how many times it can be rotated.



The *N* can be rotated twice. This means the angle of rotation is 180° .

**Example C**

Determine if the figure below has rotational symmetry. Find the angle and how many times it can be rotated.

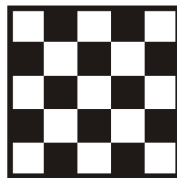

The checkerboard can be rotated 4 times. There are 4 lines of rotational symmetry, so the angle of rotation is $\frac{360^\circ}{4} = 90^\circ$.

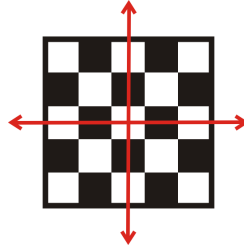
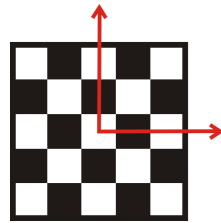

MEDIA

Click image to the left for more content.

RotationSymmetry CK-12

Guided Practice

Find the angle of rotation and the number of times each figure can rotate.

1.



2.

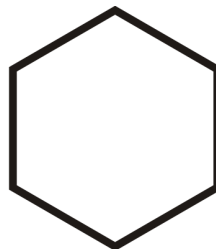

3.

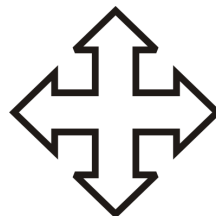

Answers:

1. The parallelogram can be rotated twice. The angle of rotation is 180° .
2. The hexagon can be rotated six times. The angle of rotation is 60° .
3. This figure can be rotated four times. The angle of rotation is 90° .

Practice

1. If a figure has 3 lines of rotational symmetry, it can be rotated _____ times.
2. If a figure can be rotated 6 times, it has _____ lines of rotational symmetry.
3. If a figure can be rotated n times, it has _____ lines of rotational symmetry.
4. To find the angle of rotation, divide 360° by the total number of _____.
5. Every square has an angle of rotation of _____.

Determine whether each statement is true or false.

6. Every parallelogram has rotational symmetry.
7. Every figure that has line symmetry also has rotational symmetry.

Determine whether the words below have rotation symmetry.

8. **OHIO**
9. **MOW**
10. **WOW**
11. **KICK**
12. **pod**

Find the angle of rotation and the number of times each figure can rotate.

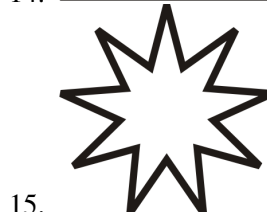
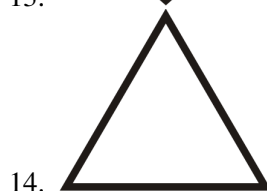
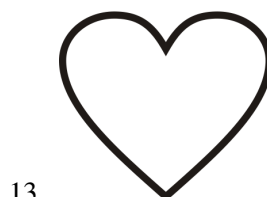

Determine if the figures below have rotation symmetry. Identify the angle of rotation.

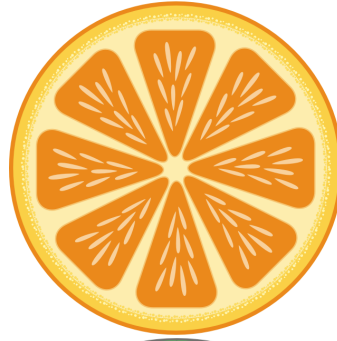

16.



17.



18.

12.3 Geometric Translations

Here you'll learn what a translation is and how to find translation rules.

What if you were given the coordinates of a quadrilateral and you were asked to move that quadrilateral 3 units to the left and 2 units down? What would its new coordinates be? After completing this Concept, you'll be able to translate a figure like this one in the coordinate plane.

Watch This



MEDIA

Click image to the left for more content.

Transformation: Translation CK-12

Guidance

A **transformation** is an operation that moves, flips, or otherwise changes a figure to create a new figure. A **rigid transformation** (also known as an **isometry** or **congruence transformation**) is a transformation that does not change the size or shape of a figure.

The rigid transformations are translations (discussed here), [Transformation: Reflection](#), and [Transformation: Rotation](#). The new figure created by a transformation is called the **image**. The original figure is called the **preimage**. If the preimage is A , then the image would be A' , said "a prime." If there is an image of A' , that would be labeled A'' , said "a double prime."

A **translation** is a transformation that moves every point in a figure the same distance in the same direction. For example, this transformation moves the parallelogram to the right 5 units and up 3 units. It is written $(x,y) \rightarrow (x+5,y+3)$.

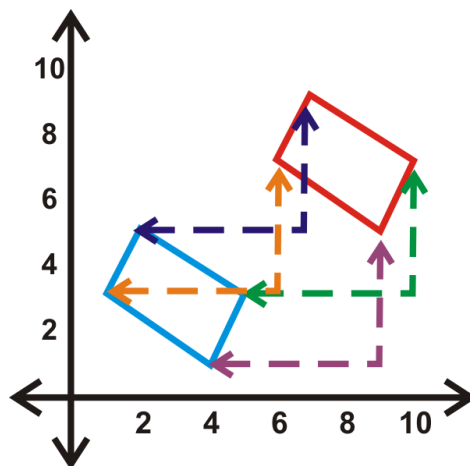

Example A

Graph square $S(1,2)$, $Q(4,1)$, $R(5,4)$ and $E(2,5)$. Find the image after the translation $(x,y) \rightarrow (x-2,y+3)$. Then, graph and label the image.

We are going to move the square to the left 2 and up 3.

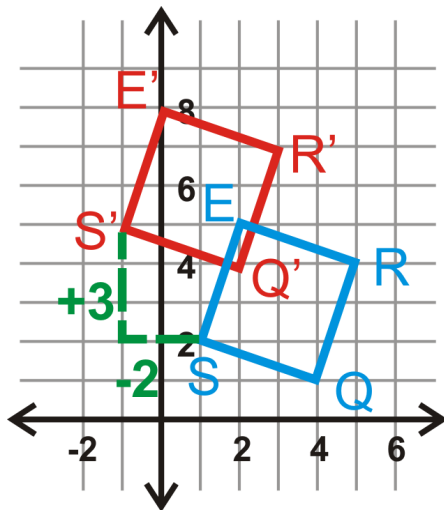

$$(x,y) \rightarrow (x-2,y+3)$$

$$S(1,2) \rightarrow S'(-1,5)$$

$$Q(4,1) \rightarrow Q'(2,4)$$

$$R(5,4) \rightarrow R'(3,7)$$

$$E(2,5) \rightarrow E'(0,8)$$

Example B

Find the translation rule for $\triangle TRI$ to $\triangle T'R'I'$.

Look at the movement from T to T' . The translation rule is $(x,y) \rightarrow (x+6,y-4)$.

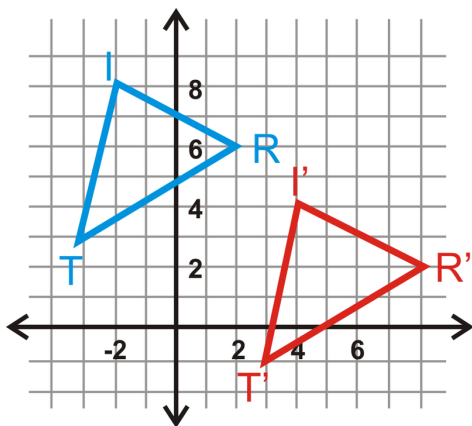

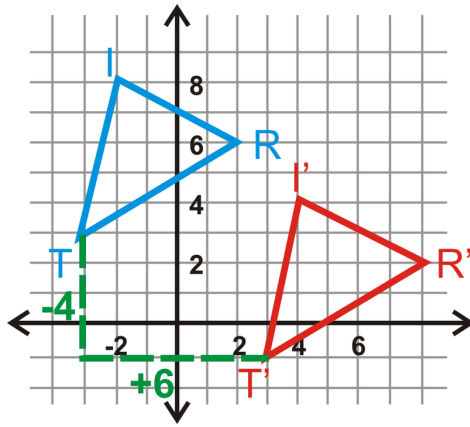

Example C

Show $\triangle TRI \cong \triangle T'R'I'$ from Example B.

Use the distance formula to find all the lengths of the sides of the two triangles.

$\triangle TRI$	$\triangle T'R'I'$
$TR = \sqrt{(-3 - 2)^2 + (3 - 6)^2} = \sqrt{34}$	$T'R' = \sqrt{(3 - 8)^2 + (-1 - 2)^2} = \sqrt{34}$
$RI = \sqrt{(2 - (-2))^2 + (6 - 8)^2} = \sqrt{20}$	$R'I' = \sqrt{(8 - 4)^2 + (2 - 4)^2} = \sqrt{20}$
$TI = \sqrt{(-3 - (-2))^2 + (3 - 8)^2} = \sqrt{26}$	$T'I' = \sqrt{(3 - 4)^2 + (-1 - 4)^2} = \sqrt{26}$

Since all three pairs of corresponding sides are congruent, the two triangles are congruent by SSS.



MEDIA

Click image to the left for more content.

Transformation: Translation CK-12

Guided Practice

1. Triangle $\triangle ABC$ has coordinates $A(3, -1)$, $B(7, -5)$ and $C(-2, -2)$. Translate $\triangle ABC$ to the left 4 units and up 5 units. Determine the coordinates of $\triangle A'B'C'$.

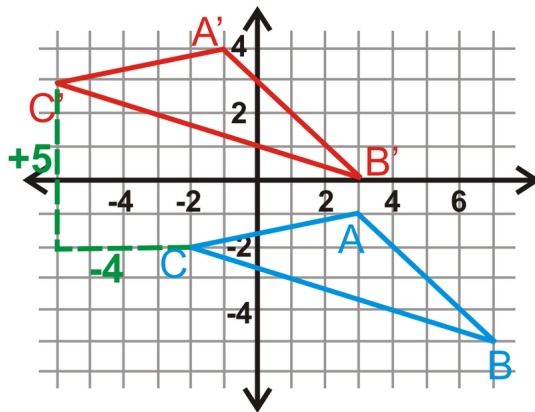

Use the translation $(x,y) \rightarrow (x+2,y-5)$ for questions 2-4.

2. What is the image of $A(-6,3)$?
3. What is the image of $B(4,8)$?
4. What is the image of $C(5,-3)$?

Answers:

1. Graph $\triangle ABC$. To translate $\triangle ABC$, subtract 4 from each x value and add 5 to each y value of its coordinates.

$$A(3, -1) \rightarrow (3 - 4, -1 + 5) = A'(-1, 4)$$

$$B(7, -5) \rightarrow (7 - 4, -5 + 5) = B'(3, 0)$$

$$C(-2, -2) \rightarrow (-2 - 4, -2 + 5) = C'(-6, 3)$$

The rule would be $(x,y) \rightarrow (x-4,y+5)$.

2. $A'(-4, -2)$
3. $B'(6, 3)$
4. $C'(7, -8)$

Practice

Use the translation $(x,y) \rightarrow (x+5,y-9)$ for questions 1-7.

1. What is the image of $A(-1, 3)$?
2. What is the image of $B(2, 5)$?
3. What is the image of $C(4, -2)$?
4. What is the image of A' ?
5. What is the preimage of $D'(12, 7)$?
6. What is the image of A'' ?
7. Plot A, A', A'' , and A''' from the questions above. What do you notice?

The vertices of $\triangle ABC$ are $A(-6, -7), B(-3, -10)$ and $C(-5, 2)$. Find the vertices of $\triangle A'B'C'$, given the translation rules below.

8. $(x,y) \rightarrow (x-2,y-7)$
9. $(x,y) \rightarrow (x+11,y+4)$

10. $(x, y) \rightarrow (x, y - 3)$
11. $(x, y) \rightarrow (x - 5, y + 8)$
12. $(x, y) \rightarrow (x + 1, y)$
13. $(x, y) \rightarrow (x + 3, y + 10)$

In questions 14-17, $\triangle A'B'C'$ is the image of $\triangle ABC$. Write the translation rule.

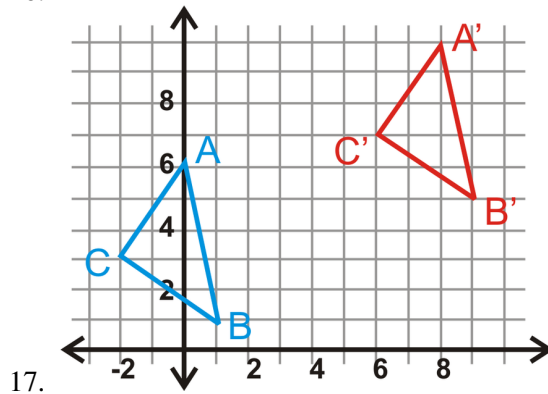
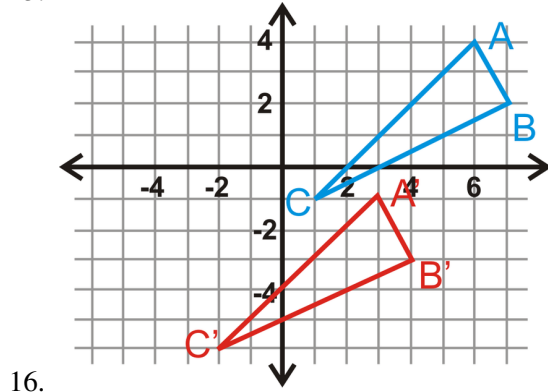
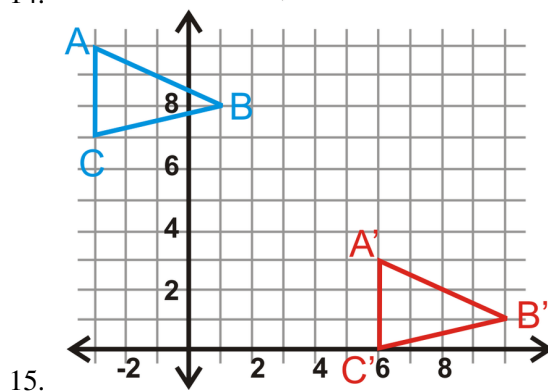
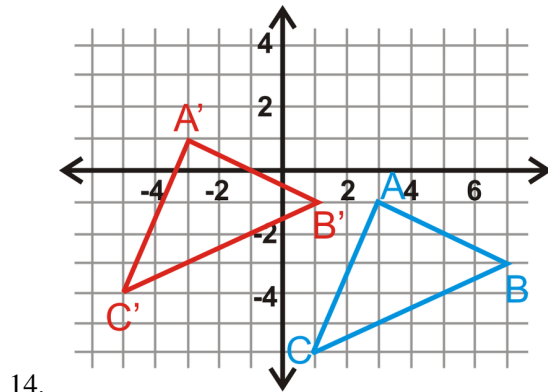

Use the triangles from #17 to answer questions 18-20.

18. Find the lengths of all the sides of $\triangle ABC$.
19. Find the lengths of all the sides of $\triangle A'B'C'$.
20. What can you say about $\triangle ABC$ and $\triangle A'B'C'$? Can you say this for any translation?
21. If $\triangle A'B'C'$ was the preimage and $\triangle ABC$ was the image, write the translation rule for #14.
22. If $\triangle A'B'C'$ was the preimage and $\triangle ABC$ was the image, write the translation rule for #15.
23. Find the translation rule that would move A to $A'(0,0)$, for #16.
24. The coordinates of $\triangle DEF$ are $D(4,-2)$, $E(7,-4)$ and $F(5,3)$. Translate $\triangle DEF$ to the right 5 units and up 11 units. Write the translation rule.
25. The coordinates of quadrilateral $QUAD$ are $Q(-6,1)$, $U(-3,7)$, $A(4,-2)$ and $D(1,-8)$. Translate $QUAD$ to the left 3 units and down 7 units. Write the translation rule.

12.4 Rotations

Here you'll learn what a rotation is and how to find the coordinates of a rotated figure.

What if you were given the coordinates of a quadrilateral and you were asked to rotate that quadrilateral 270° about the origin? What would its new coordinates be? After completing this Concept, you'll be able to rotate a figure like this one in the coordinate plane.

Watch This



MEDIA

Click image to the left for more content.

Transformation: RotationCK-12

Guidance

A **transformation** is an operation that moves, flips, or otherwise changes a figure to create a new figure. A **rigid transformation** (also known as an **isometry** or **congruence transformation**) is a transformation that does not change the size or shape of a figure.

The rigid transformations are [Transformation: Translation](#), [Transformation: Reflection](#), and rotations (discussed here). The new figure created by a transformation is called the **image**. The original figure is called the **preimage**. If the preimage is A , then the image would be A' , said "a prime." If there is an image of A' , that would be labeled A'' , said "a double prime."

A **rotation** is a transformation where a figure is turned around a fixed point to create an image. The lines drawn from the preimage to the **center of rotation** and from the center of rotation to the image form the **angle of rotation**. In this concept, we will only do *counterclockwise rotations*.

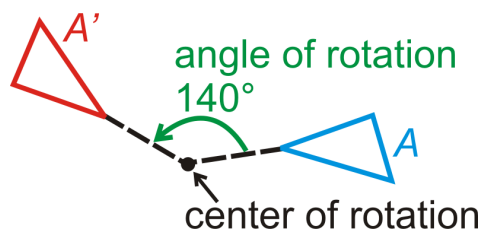

While we can rotate any image any amount of degrees, 90° , 180° and 270° rotations are common and have rules worth memorizing.

Rotation of 180° : $(x,y) \rightarrow (-x,-y)$

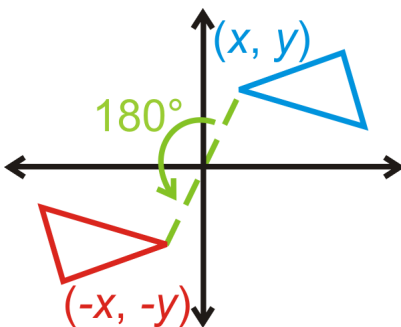

Rotation of 90° : $(x,y) \rightarrow (-y,x)$

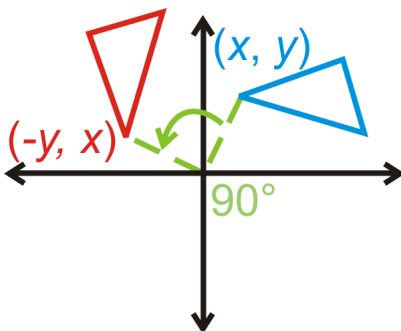

Rotation of 270° : $(x,y) \rightarrow (y,-x)$

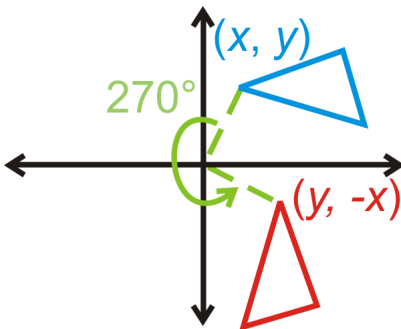

Example A

A rotation of 80° clockwise is the same as what counterclockwise rotation?

There are 360° around a point. So, an 80° rotation clockwise is the same as a $360^\circ - 80^\circ = 280^\circ$ rotation counterclockwise.

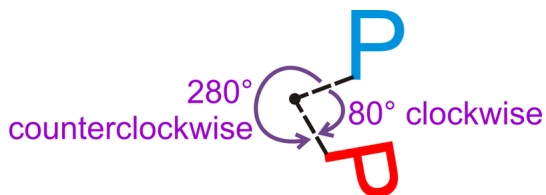

Example B

A rotation of 160° counterclockwise is the same as what clockwise rotation?

$360^\circ - 160^\circ = 200^\circ$ clockwise rotation.

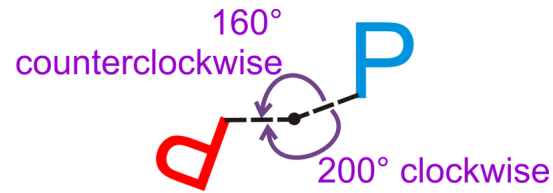

Example C

Rotate $\triangle ABC$, with vertices $A(7,4)$, $B(6,1)$, and $C(3,1)$, 180° about the origin. Find the coordinates of $\triangle A'B'C'$.

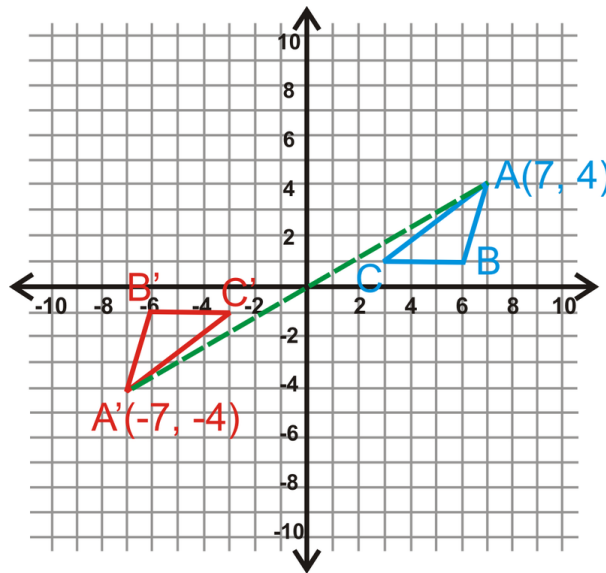

Use the rule above to find $\triangle A'B'C'$.

$$A(7,4) \rightarrow A'(-7,-4)$$

$$B(6,1) \rightarrow B'(-6,-1)$$

$$C(3,1) \rightarrow C'(-3,-1)$$



MEDIA

Click image to the left for more content.

Transformation: RotationCK-12

Guided Practice

1. Rotate \overline{ST} 90° .

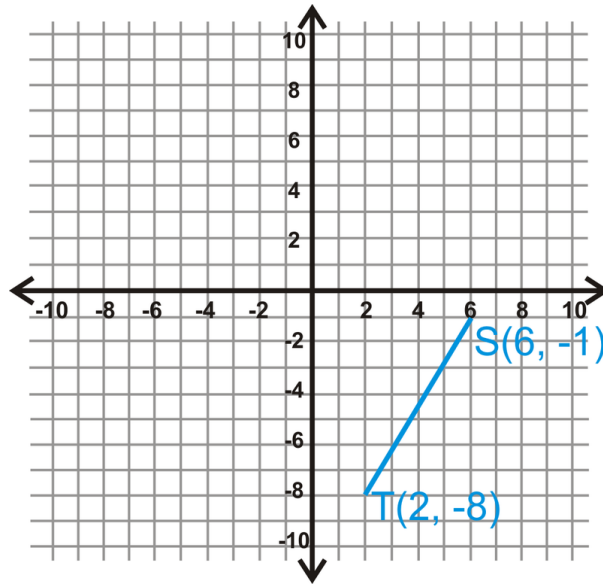

2. Find the coordinates of $ABCD$ after a 270° rotation.

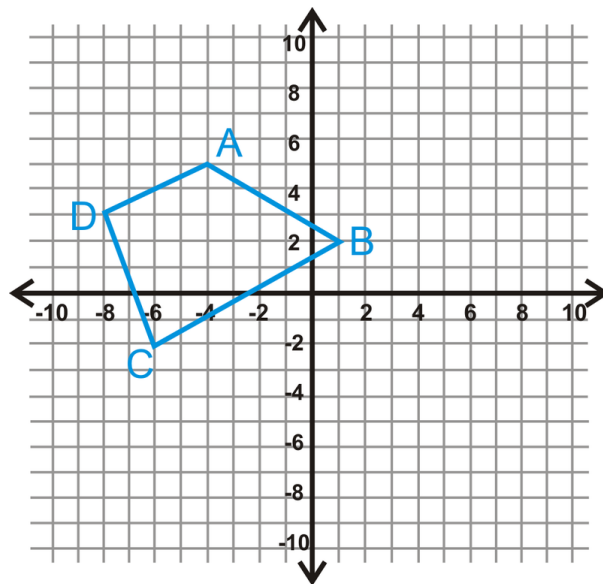

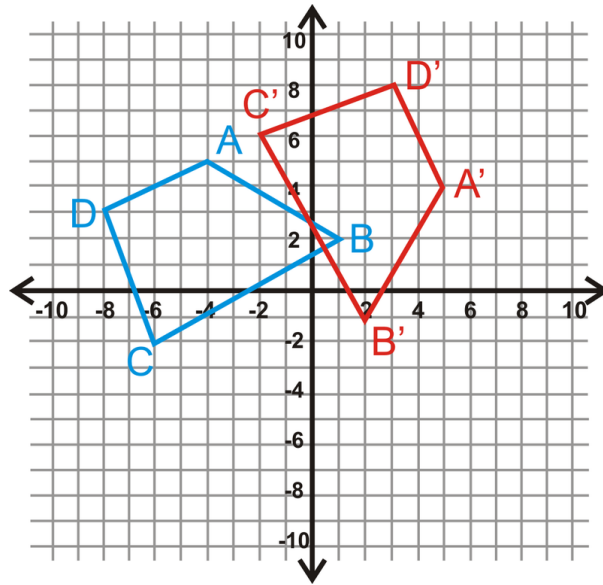

3. The rotation of a quadrilateral is shown below. What is the measure of x and y ?

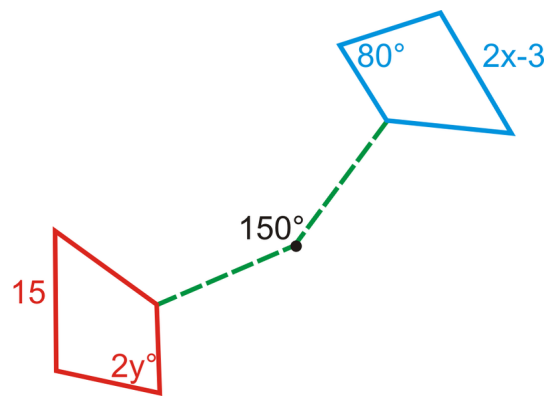

Answers:

1.

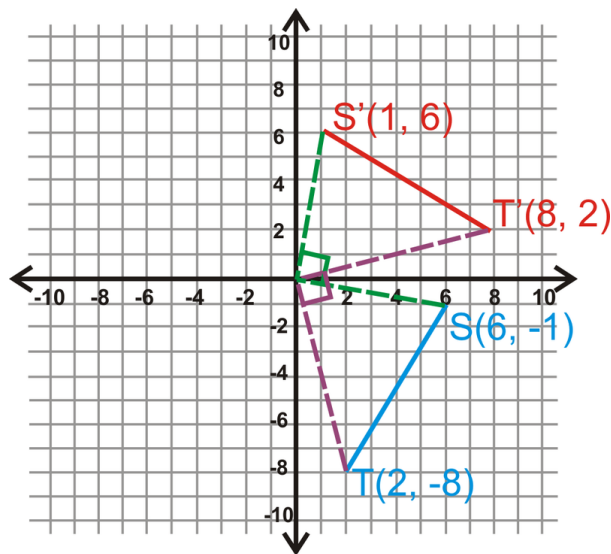

2. Using the rule, we have:

$$\begin{aligned}(x, y) &\rightarrow (y, -x) \\ A(-4, 5) &\rightarrow A'(5, 4) \\ B(1, 2) &\rightarrow B'(2, -1) \\ C(-6, -2) &\rightarrow C'(-2, 6) \\ D(-8, 3) &\rightarrow D'(3, 8)\end{aligned}$$

3. Because a rotation produces congruent figures, we can set up two equations to solve for x and y .

$$\begin{array}{rcl} 2y = 80^\circ & & 2x - 3 = 15 \\ y = 40^\circ & & 2x = 18 \\ & & x = 9 \end{array}$$

Practice

In the questions below, every rotation is counterclockwise, unless otherwise stated.

1. If you rotated the letter p 180° counterclockwise, what letter would you have?
2. If you rotated the letter p 180° clockwise, what letter would you have?
3. A 90° clockwise rotation is the same as what counterclockwise rotation?
4. A 270° clockwise rotation is the same as what counterclockwise rotation?
5. A 210° counterclockwise rotation is the same as what clockwise rotation?
6. A 120° counterclockwise rotation is the same as what clockwise rotation?
7. A 340° counterclockwise rotation is the same as what clockwise rotation?
8. Rotating a figure 360° is the same as what other rotation?
9. Does it matter if you rotate a figure 180° clockwise or counterclockwise? Why or why not?
10. When drawing a rotated figure and using your protractor, would it be easier to rotate the figure 300° counterclockwise or 60° clockwise? Explain your reasoning.

Rotate each figure in the coordinate plane the given angle measure. The center of rotation is the origin.

11. 180°

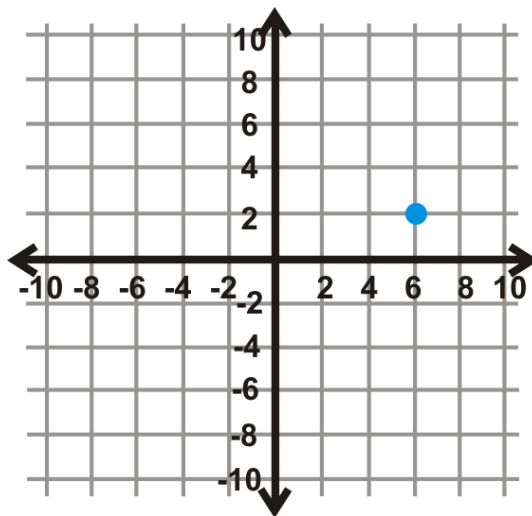

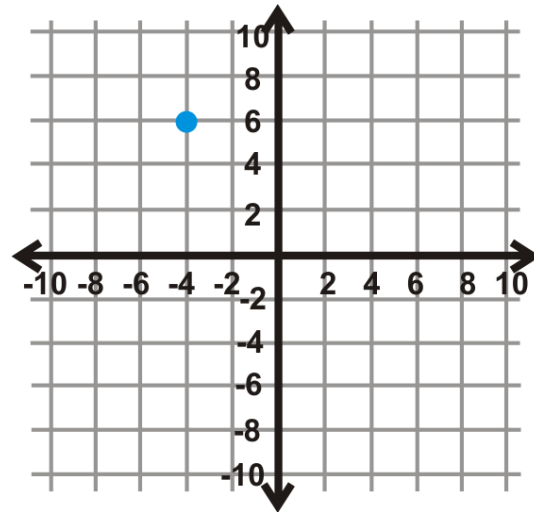
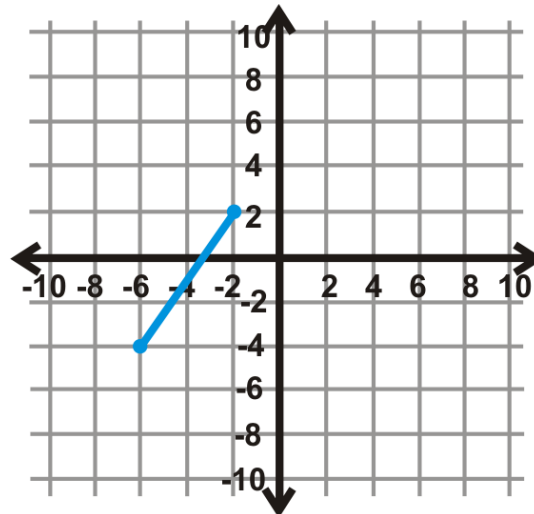
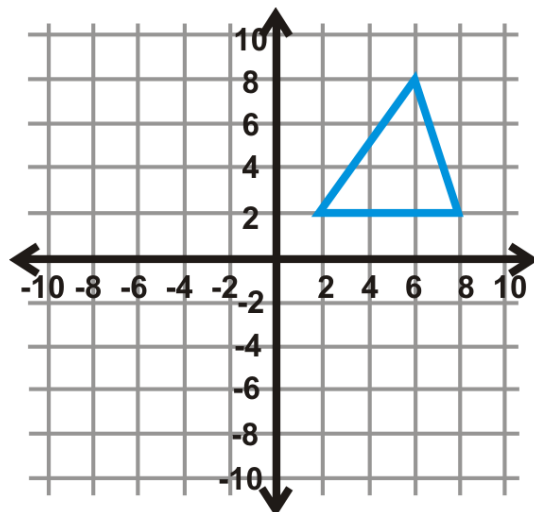
12. 90° 13. 180° 14. 270° 15. 90°

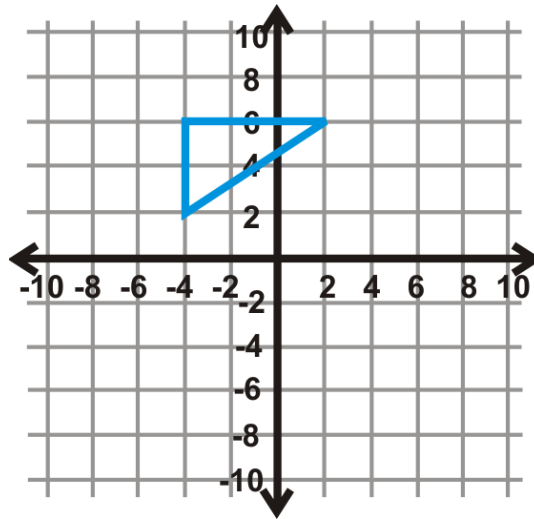

16. 270°

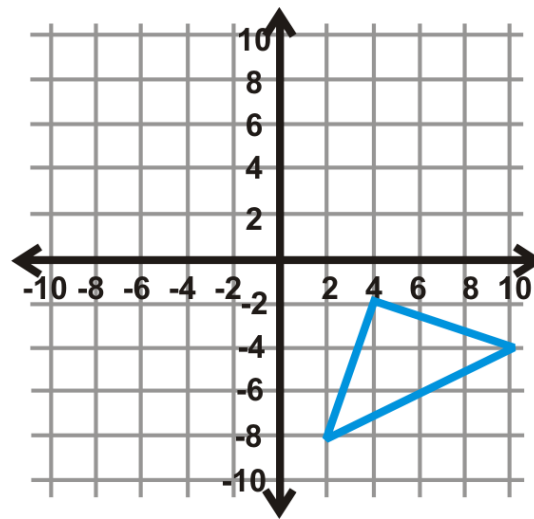

17. 180°

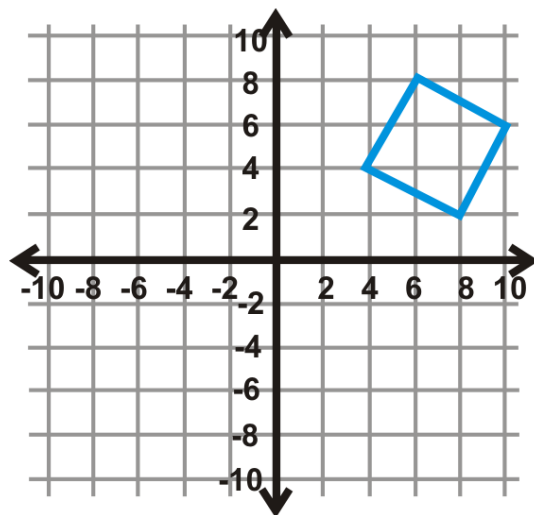

18. 270°

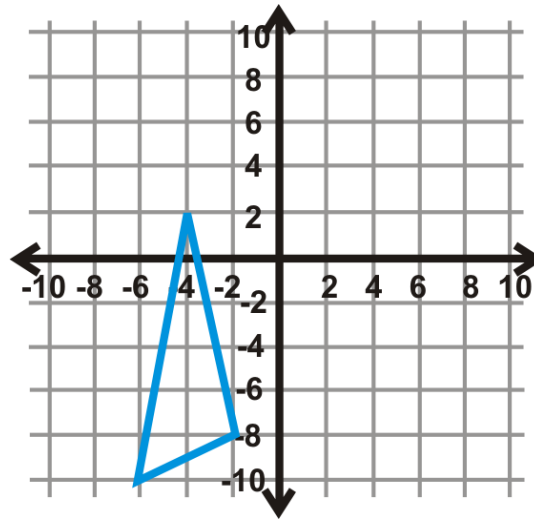

19. 90°

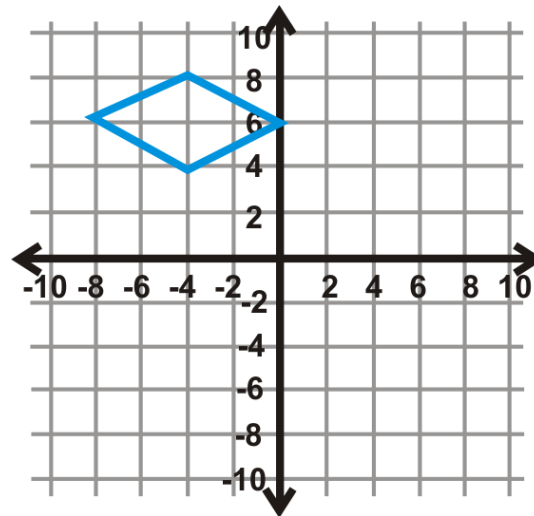

Find the measure of x in the rotations below. The blue figure is the preimage.

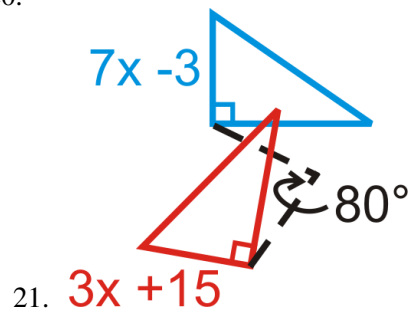
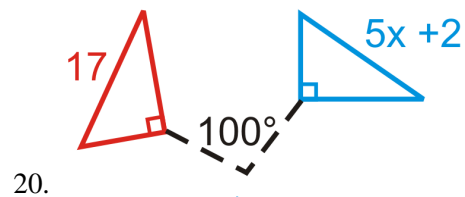

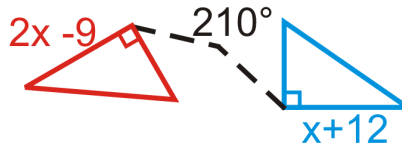

22.

Find the angle of rotation for the graphs below. The center of rotation is the origin and the blue figure is the preimage.

Your answer will be 90° , 270° , or 180° .

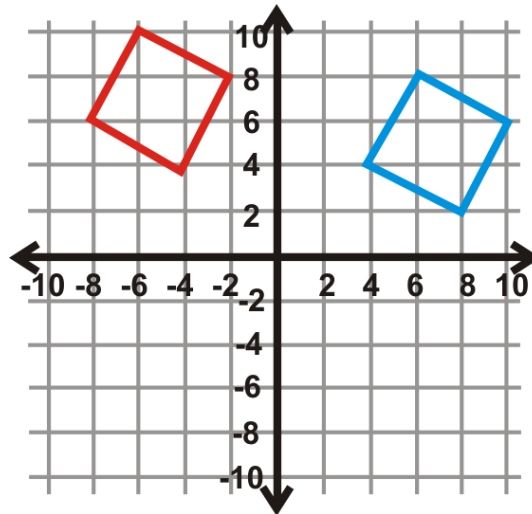

23.

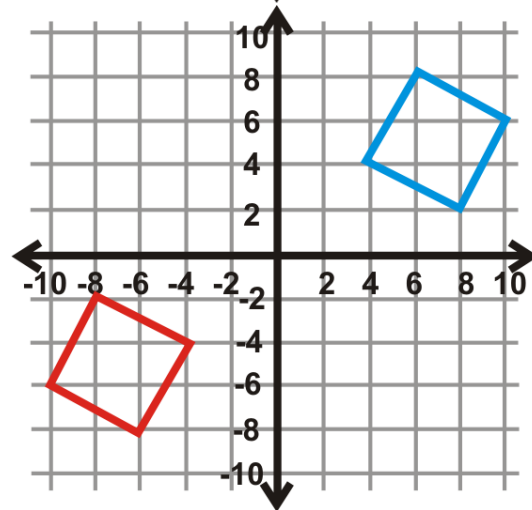

24.

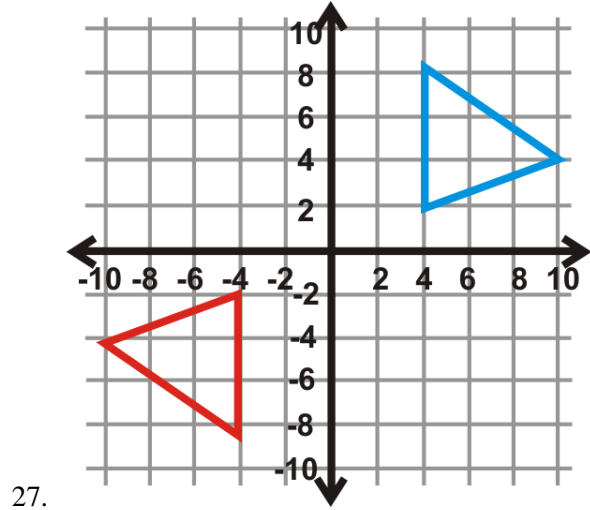
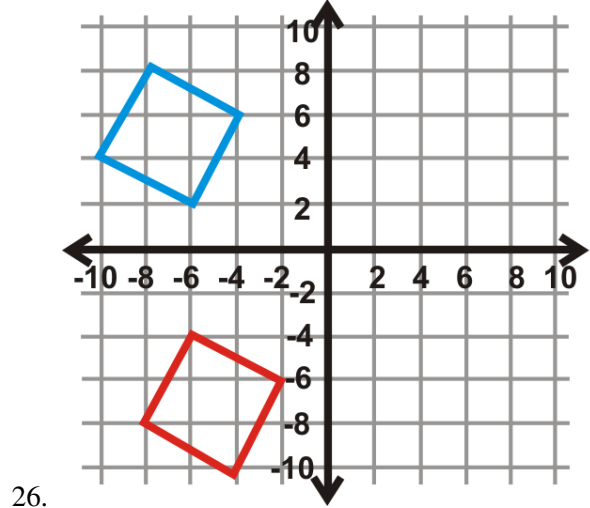
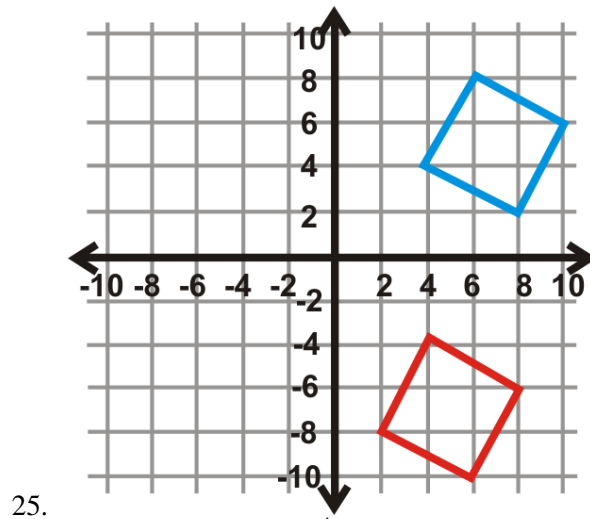

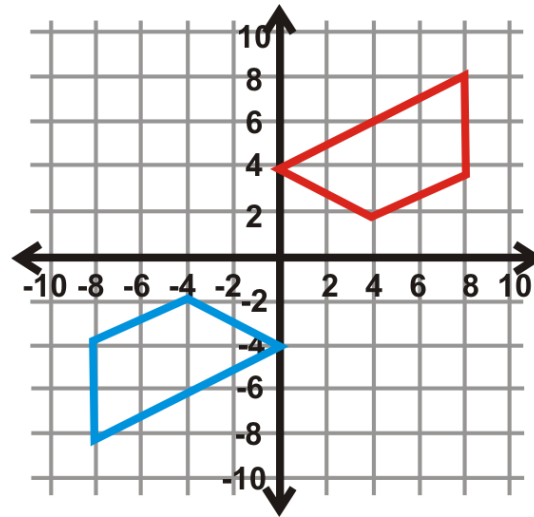

28.

12.5 Reflections

Here you'll learn what a reflection is and how to find the coordinates of a reflected figure.

What if you were given the coordinates of a quadrilateral and you were asked to reflect that quadrilateral over the y -axis? What would its new coordinates be? After completing this Concept, you'll be able to reflect a figure like this one in the coordinate plane.

Watch This



MEDIA

Click image to the left for more content.

[Transformation: Reflection CK-12](#)

Guidance

A **transformation** is an operation that moves, flips, or otherwise changes a figure to create a new figure. A **rigid transformation** (also known as an **isometry** or **congruence transformation**) is a transformation that does not change the size or shape of a figure.

The rigid transformations are [Transformation: Translation](#), reflections (discussed here), and [Transformation: Rotation](#). The new figure created by a transformation is called the **image**. The original figure is called the **preimage**. If the preimage is A , then the image would be A' , said "a prime." If there is an image of A' , that would be labeled A'' , said "a double prime."

A **reflection** is a transformation that turns a figure into its mirror image by flipping it over a line. The **line of reflection** is the line that a figure is reflected over. If a point is on the line of reflection then the image is the same as the preimage. Images are always congruent to preimages.

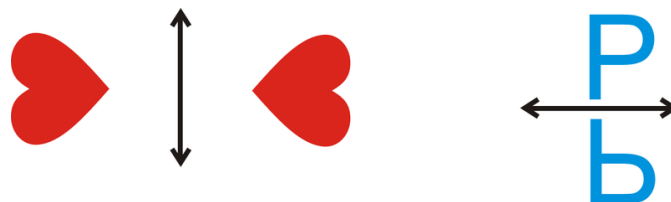

While you can reflect over any line, some common lines of reflection have rules that are worth memorizing:

Reflection over the y -axis: $(x, y) \rightarrow (-x, y)$

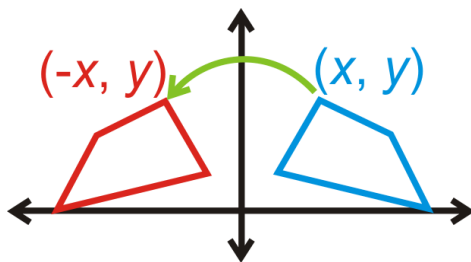

Reflection over the x -axis: $(x, y) \rightarrow (x, -y)$

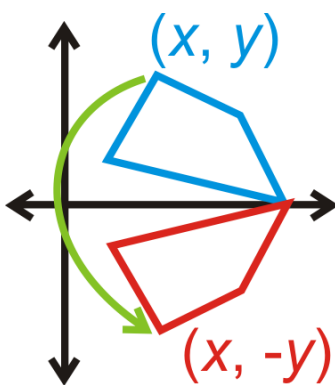

Reflection over $y = x$: $(x, y) \rightarrow (y, x)$

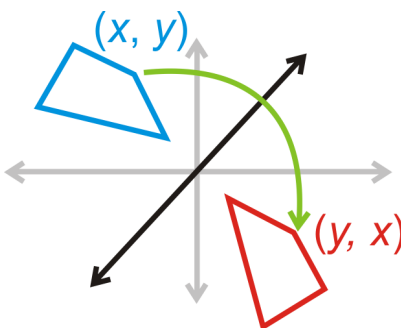

Reflection over $y = -x$: $(x, y) \rightarrow (-y, -x)$

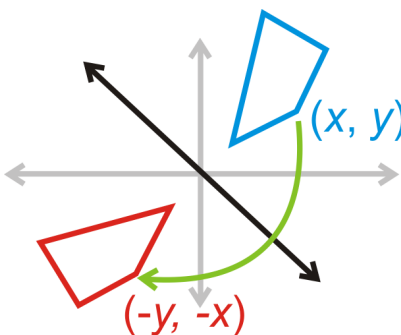

Example A

Reflect $\triangle ABC$ over the y -axis. Find the coordinates of the image.

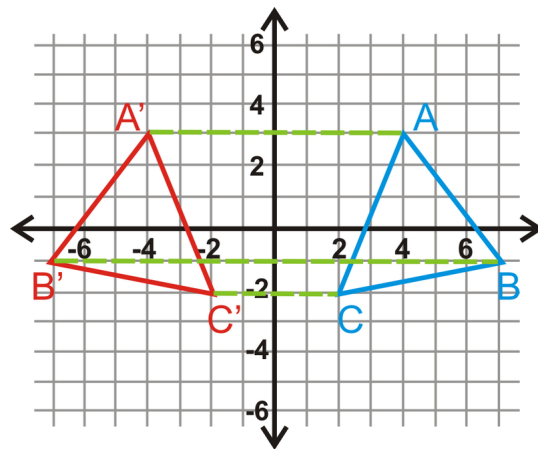
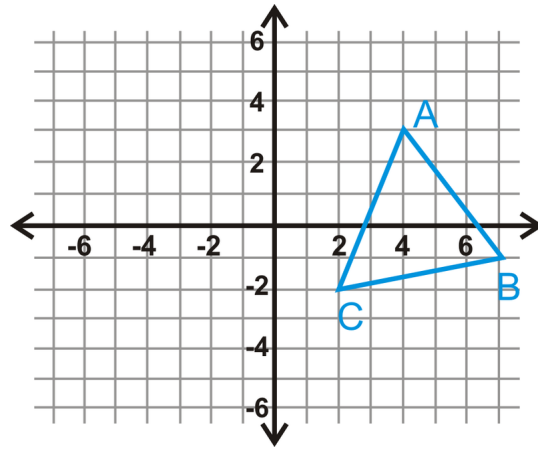

$\triangle A'B'C'$ will be the same distance away from the y -axis as $\triangle ABC$, but on the other side. Hence, their x -coordinates will be opposite.

$$A(4, 3) \rightarrow A'(-4, 3)$$

$$B(7, -1) \rightarrow B'(-7, -1)$$

$$C(2, -2) \rightarrow C'(-2, -2)$$

Example B

Reflect the letter “ F ” over the x -axis.

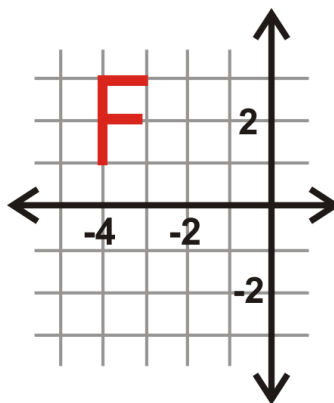

When reflecting the letter F over the x -axis, the y -coordinates will be the same distance away from the x -axis, but on the other side of the x -axis. Hence, their y -coordinates will be opposite.

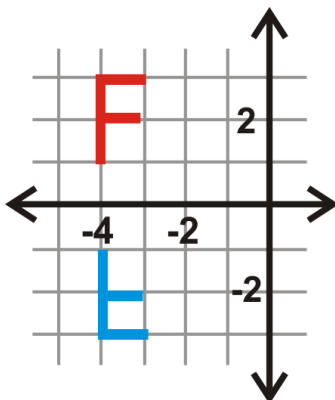

Example C

Reflect the triangle $\triangle ABC$ with vertices $A(4,5)$, $B(7,1)$ and $C(9,6)$ over the line $x = 5$. Find the coordinates of A' , B' , and C' .

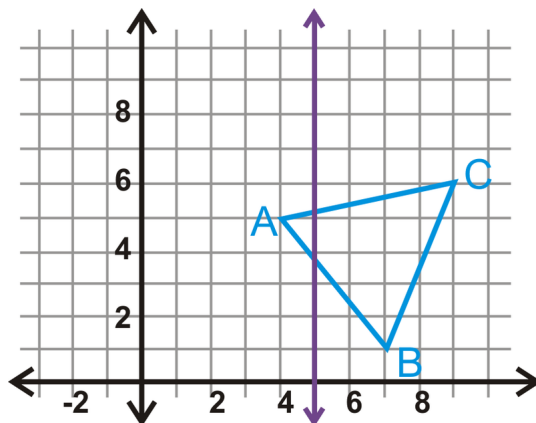

The image's vertices are the same distance away from $x = 5$ as those of the preimage.

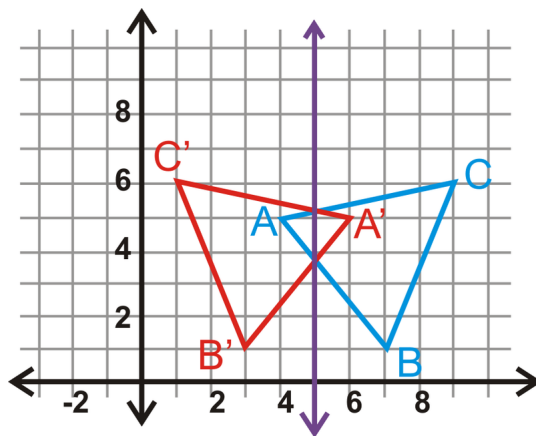

$$A(4,5) \rightarrow A'(6,5)$$

$$B(7,1) \rightarrow B'(3,1)$$

$$C(9,6) \rightarrow C'(1,6)$$



MEDIA

Click image to the left for more content.

Transformation: Reflection CK-12

Guided Practice

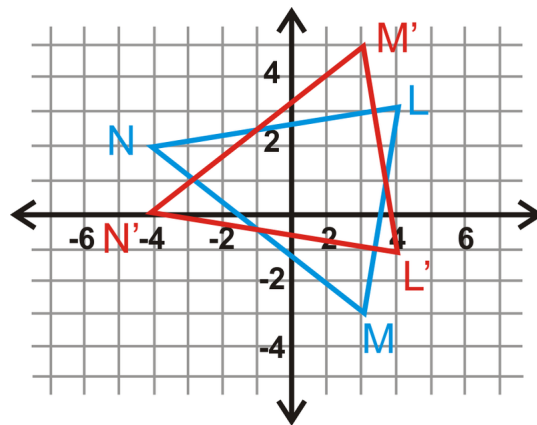
1. Reflect the line segment \overline{PQ} with endpoints $P(-1,5)$ and $Q(7,8)$ over the line $y = 5$.
2. A triangle $\triangle LMN$ and its reflection, $\triangle L'M'N'$ are below. What is the line of reflection?



3. Reflect square $ABCD$ over the line $y = x$.

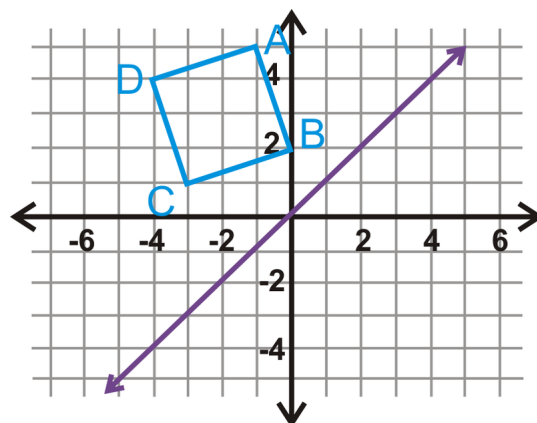

4. Reflect the trapezoid $TRAP$ over the line $y = -x$.

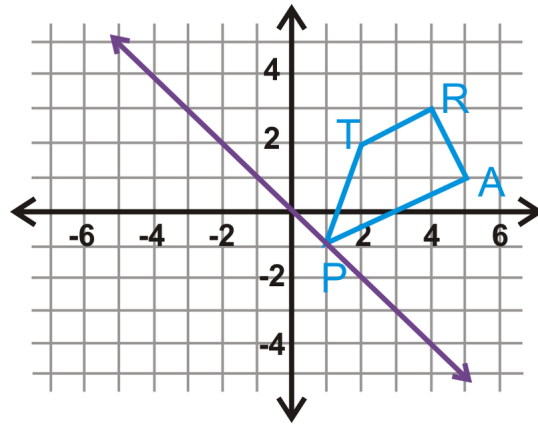

Answers:

1. P is on the line of reflection, which means P' has the same coordinates. Q' is the same distance away from $y = 5$, but on the other side.

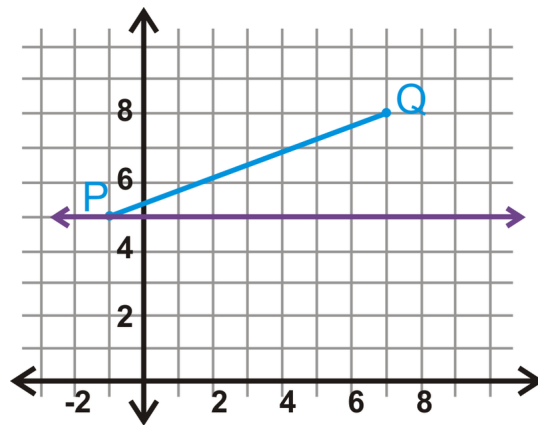

$$P(-1, 5) \rightarrow P'(-1, 5)$$

$$Q(7, 8) \rightarrow Q'(7, 2)$$

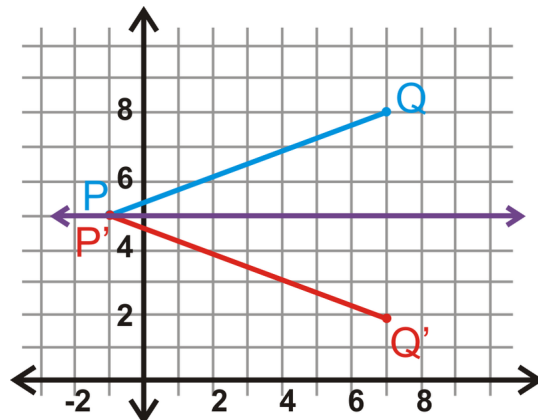

2. Looking at the graph, we see that the corresponding parts of the preimage and image intersect when $y = 1$. Therefore, this is the line of reflection.

If the image does not intersect the preimage, find the midpoint between the preimage point and its image. This point is on the line of reflection.

3. The purple line is $y = x$. Fold the graph on the line of reflection.

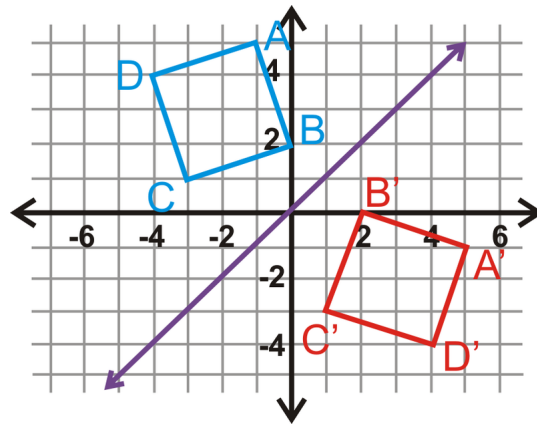

$$A(-1, 5) \rightarrow A'(5, -1)$$

$$B(0, 2) \rightarrow B'(2, 0)$$

$$C(-3, 1) \rightarrow C'(1, -3)$$

$$D(-4, 4) \rightarrow D'(4, -4)$$

4. The purple line is $y = -x$. You can reflect the trapezoid over this line.

$$T(2, 2) \rightarrow T'(-2, -2)$$

$$R(4, 3) \rightarrow R'(-3, -4)$$

$$A(5, 1) \rightarrow A'(-1, -5)$$

$$P(1, -1) \rightarrow P'(1, -1)$$

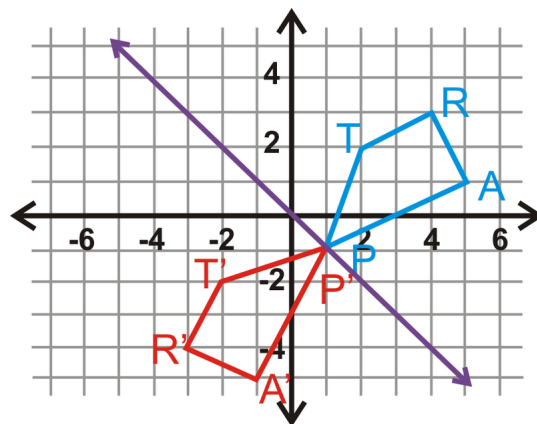

Practice

1. If $(5, 3)$ is reflected over the y -axis, what is the image?
2. If $(5, 3)$ is reflected over the x -axis, what is the image?

3. If $(5, 3)$ is reflected over $y = x$, what is the image?
4. If $(5, 3)$ is reflected over $y = -x$, what is the image?
5. Plot the four images. What shape do they make? Be specific.
6. Which letter is a reflection over a vertical line of the letter "b"?
7. Which letter is a reflection over a horizontal line of the letter "b"?

Reflect each shape over the given line.

8. y -axis

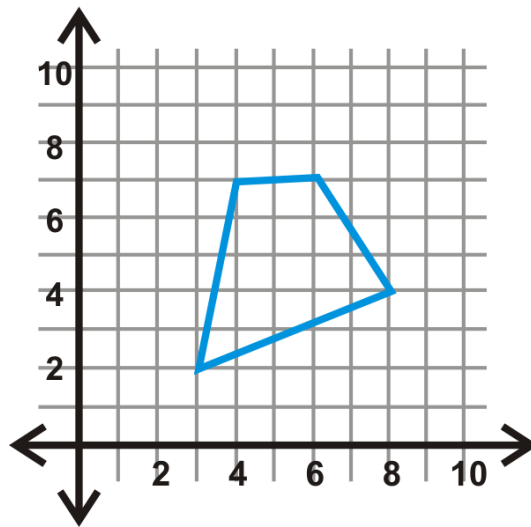

9. x -axis

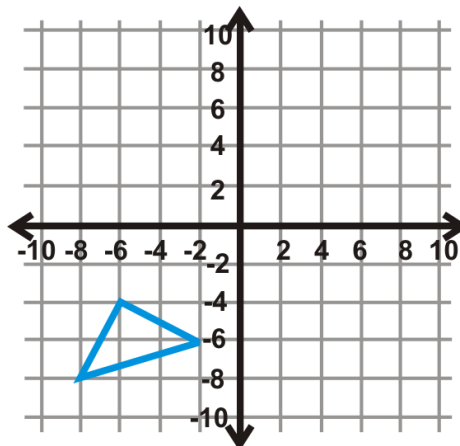

10. $y = 3$

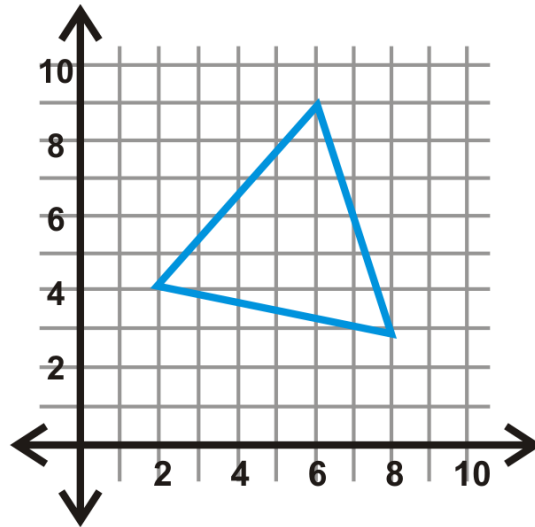
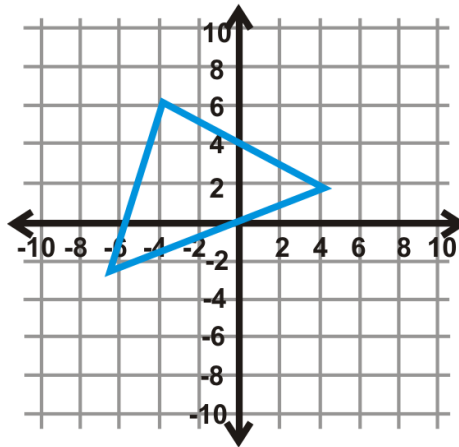
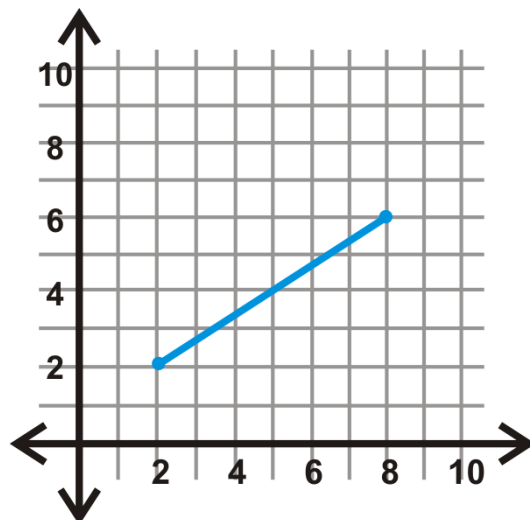
11. $x = -1$ 12. x -axis13. y -axis

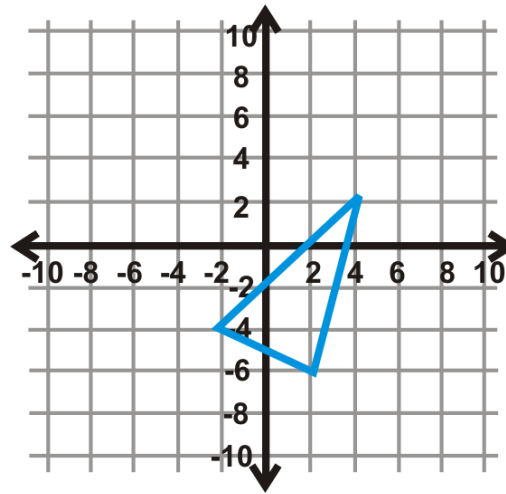

14. $y = x$

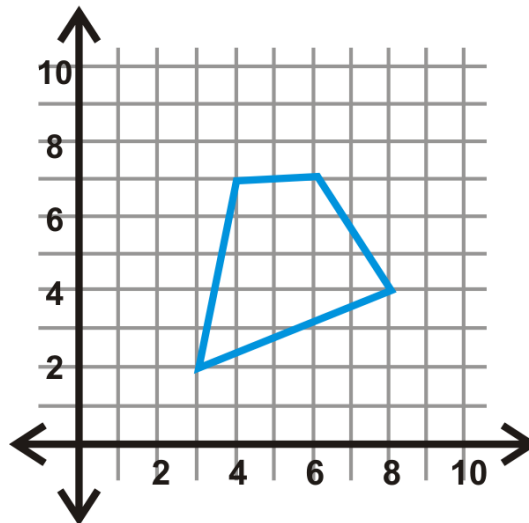

15. $y = -x$

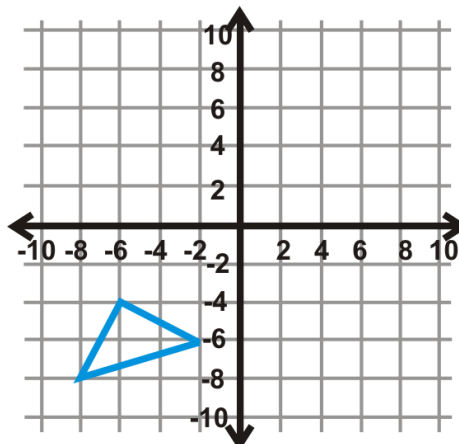

16. $x = 2$

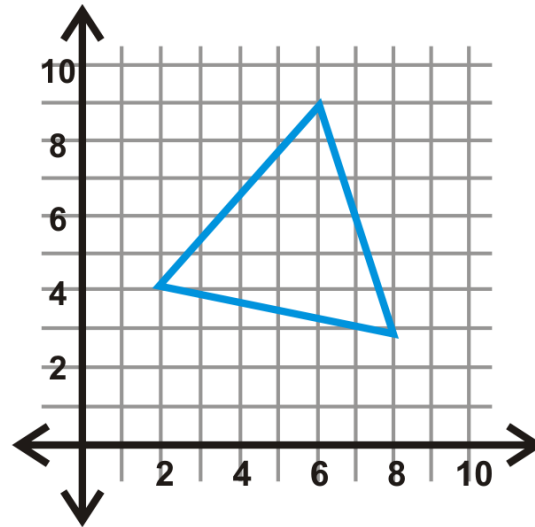

17. $y = -4$

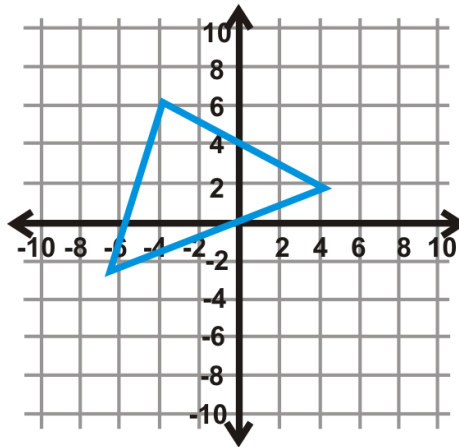

18. $y = -x$

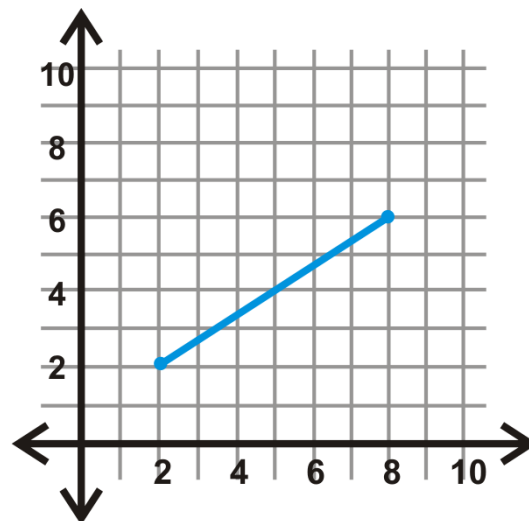

19. $y = x$

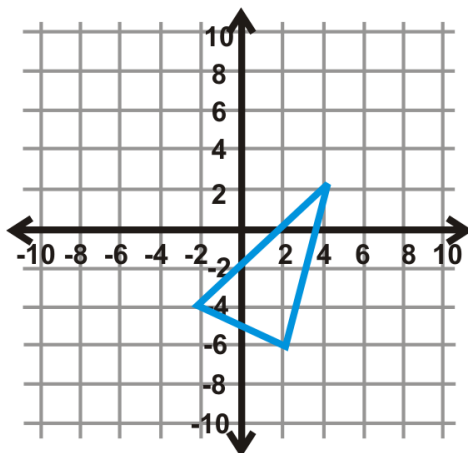

Find the line of reflection the blue triangle (preimage) and the red triangle (image).

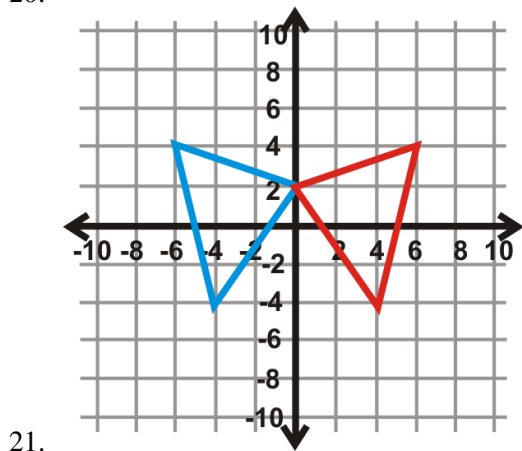
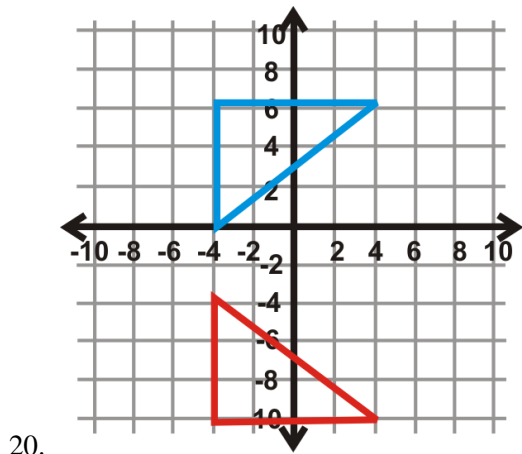

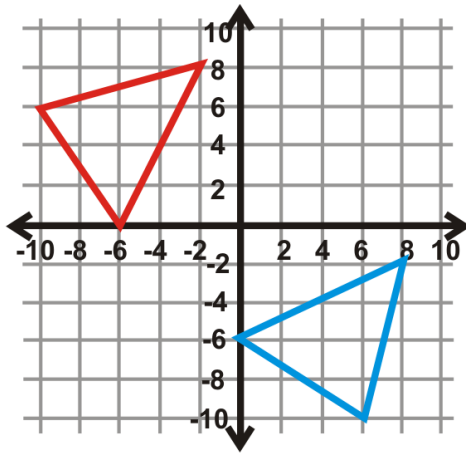

22.

12.6 Composition of Transformations

Here you'll learn how to perform a composition of transformations. You'll also learn several theorems related to composing transformations.

What if you were given the coordinates of a quadrilateral and you were asked to reflect the quadrilateral and then translate it? What would its new coordinates be? After completing this Concept, you'll be able to perform a series of transformations on a figure like this one in the coordinate plane.

Watch This



MEDIA

Click image to the left for more content.

[Composing Transformations CK-12](#)

Guidance

Transformations Summary

A **transformation** is an operation that moves, flips, or otherwise changes a figure to create a new figure. A **rigid transformation** (also known as an **isometry** or **congruence transformation**) is a transformation that does not change the size or shape of a figure. The new figure created by a transformation is called the **image**. The original figure is called the **preimage**.

There are three rigid transformations: translations, rotations and reflections. A **translation** is a transformation that moves every point in a figure the same distance in the same direction. A **rotation** is a transformation where a figure is turned around a fixed point to create an image. A **reflection** is a transformation that turns a figure into its mirror image by flipping it over a line.

Composition of Transformations

A **composition (of transformations)** is when more than one transformation is performed on a figure. Compositions can always be written as one rule. You can compose any transformations, but here are some of the most common compositions:

1) A **glide reflection** is a composition of a reflection and a translation. The translation is in a direction parallel to the line of reflection.

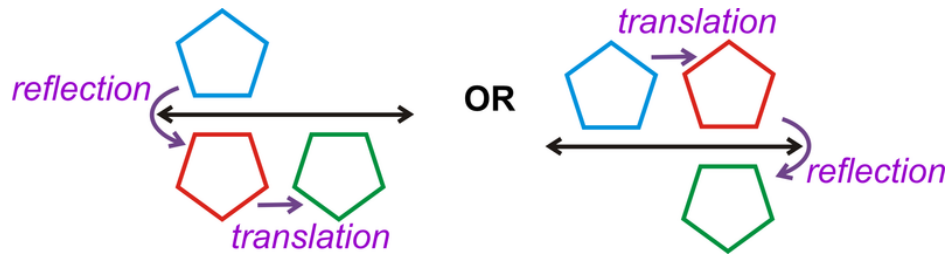

2) The composition of two reflections over parallel lines that are h units apart is the same as a translation of $2h$ units (**Reflections over Parallel Lines Theorem**).

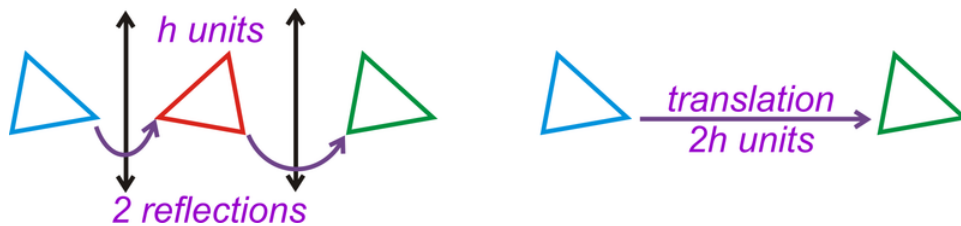

3) If you compose two reflections over each axis, then the final image is a rotation of 180° around the origin of the original (**Reflection over the Axes Theorem**).

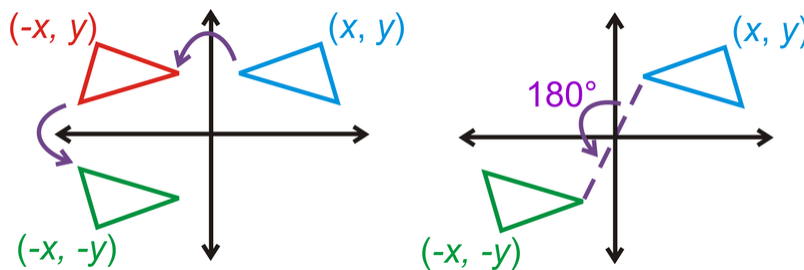

4) A composition of two reflections over lines that intersect at x° is the same as a rotation of $2x^\circ$. The center of rotation is the point of intersection of the two lines of reflection (**Reflection over Intersecting Lines Theorem**).

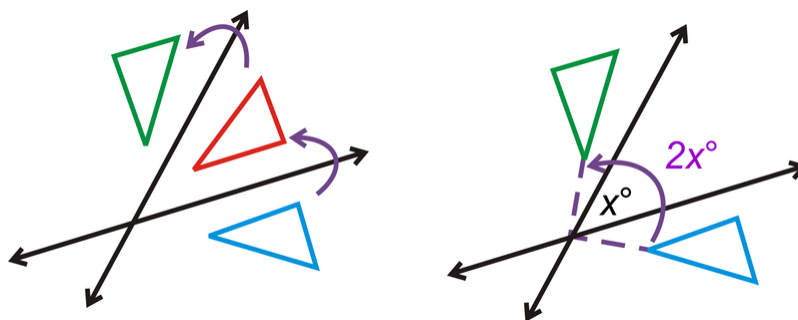

Example A

Reflect $\triangle ABC$ over the y -axis and then translate the image 8 units down.

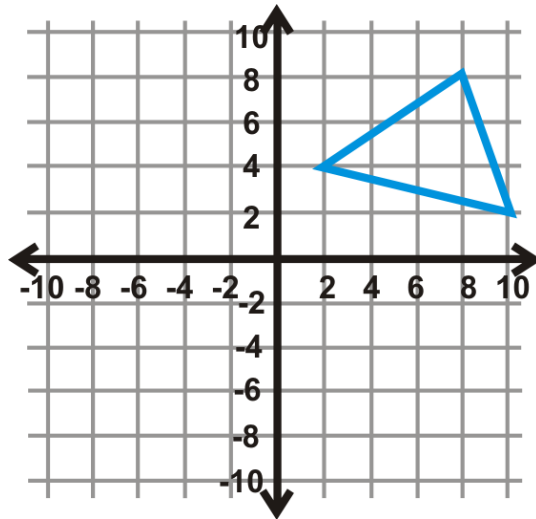

The green image to the right is the final answer.

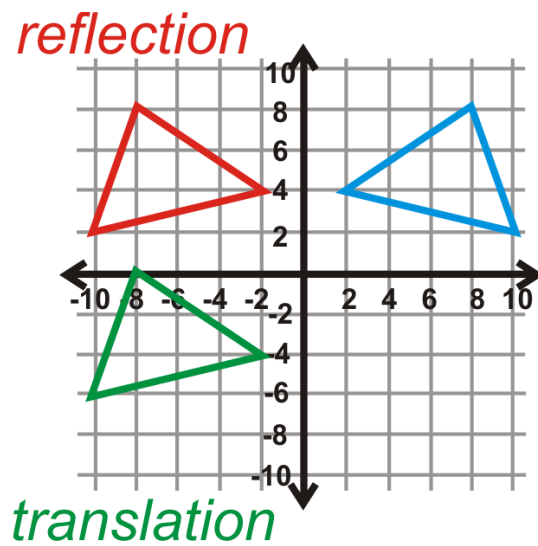

$$A(8, 8) \rightarrow A''(-8, 0)$$

$$B(2, 4) \rightarrow B''(-2, -4)$$

$$C(10, 2) \rightarrow C''(-10, -6)$$

Example B

Write a single rule for $\triangle ABC$ to $\triangle A''B''C''$ from Example A.

Looking at the coordinates of A to A'' , the x -value is the opposite sign and the y -value is $y - 8$. Therefore the rule would be $(x, y) \rightarrow (-x, y - 8)$.

Example C

Reflect $\triangle ABC$ over $y = 3$ and then reflect the image over $y = -5$.

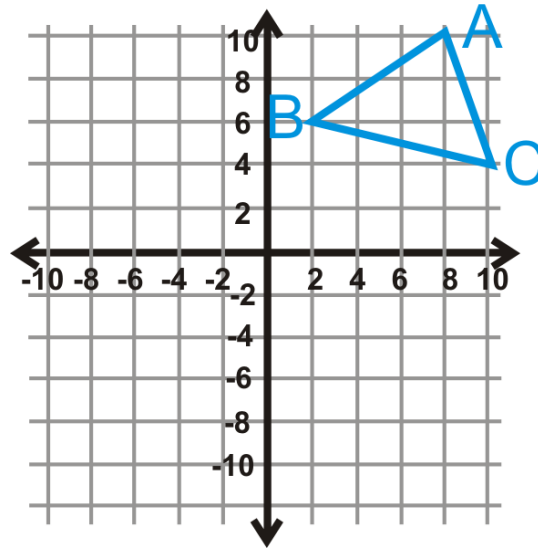

Order matters, so you would reflect over $y = 3$ first, (red triangle) then reflect it over $y = -5$ (green triangle).

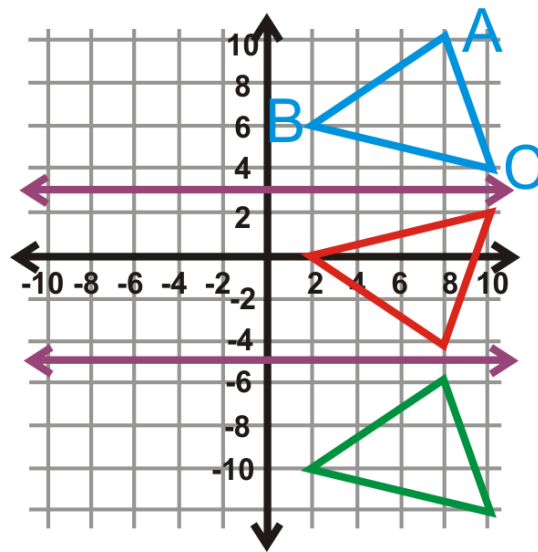

Example D

A square is reflected over two lines that intersect at a 79° angle. What one transformation will this be the same as?
From the Reflection over Intersecting Lines Theorem, this is the same as a rotation of $2 \cdot 79^\circ = 178^\circ$.



MEDIA

Click image to the left for more content.

[Composing Transformations CK-12](#)

Guided Practice

1. Write a single rule for $\triangle ABC$ to $\triangle A''B''C''$ from Example C.

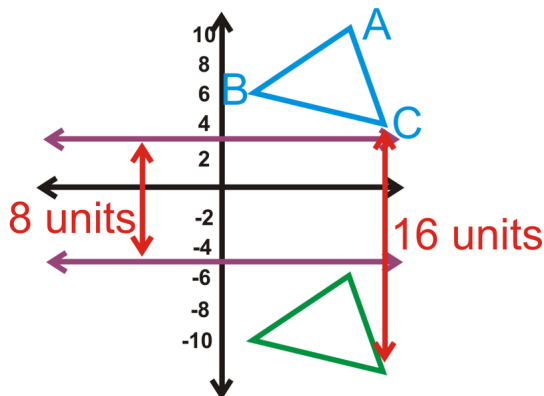

2. $\triangle DEF$ has vertices $D(3, -1)$, $E(8, -3)$, and $F(6, 4)$. Reflect $\triangle DEF$ over $x = -5$ and then $x = 1$. Determine which one translation this double reflection would be the same as.

3. Reflect $\triangle DEF$ from Question 2 over the x -axis, followed by the y -axis. Find the coordinates of $\triangle D''E''F''$ and the one transformation this double reflection is the same as.

4. Copy the figure below and reflect the triangle over l , followed by m .

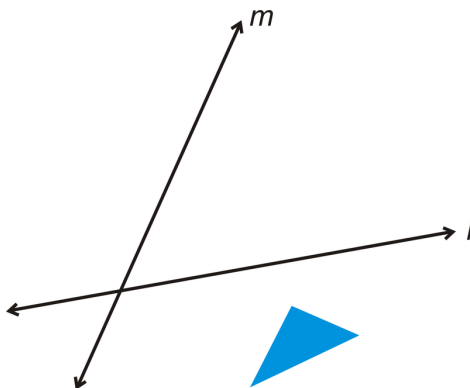

Answers:

1. In the graph, the two lines are 8 units apart ($3 - (-5) = 8$). The figures are 16 units apart. The **double** reflection is the same as a translation that is **double** the distance between the parallel lines. $(x, y) \rightarrow (x, y - 16)$.

2. From the Reflections over Parallel Lines Theorem, we know that this double reflection is going to be the same as a single translation of $2(1 - (-5))$ or 12 units.

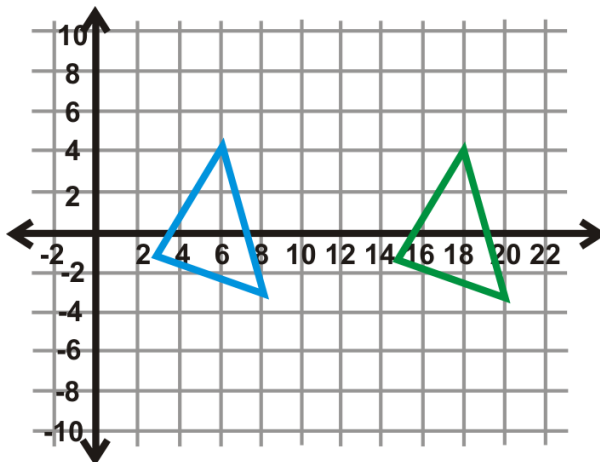

3. $\triangle D''E''F''$ is the green triangle in the graph to the left. If we compare the coordinates of it to $\triangle DEF$, we have:

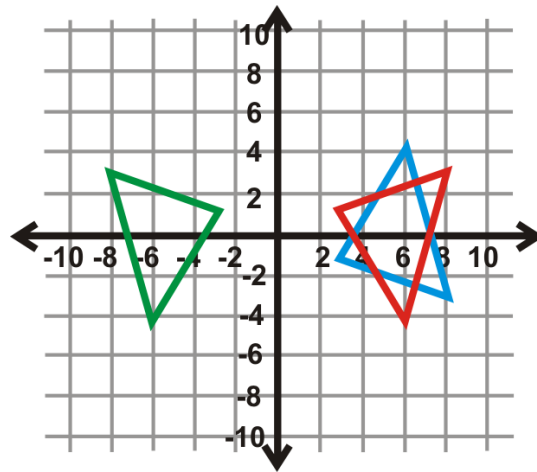

$$D(3, -1) \rightarrow D''(-3, 1)$$

$$E(8, -3) \rightarrow E''(-8, 3)$$

$$F(6, 4) \rightarrow F''(-6, -4)$$

4. The easiest way to reflect the triangle is to fold your paper on each line of reflection and draw the image. The final result should look like this (the green triangle is the final answer):

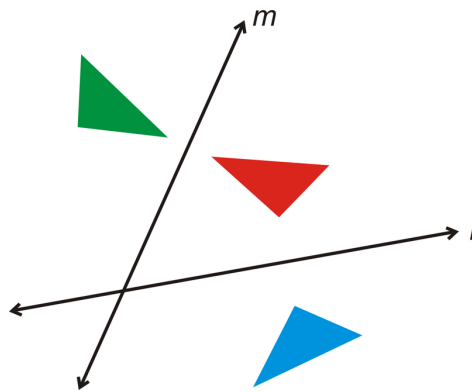

Practice

1. Explain why the composition of two or more isometries must also be an isometry.
2. What one transformation is the same as a reflection over two parallel lines?
3. What one transformation is the same as a reflection over two intersecting lines?

Use the graph of the square to the left to answer questions 4-6.

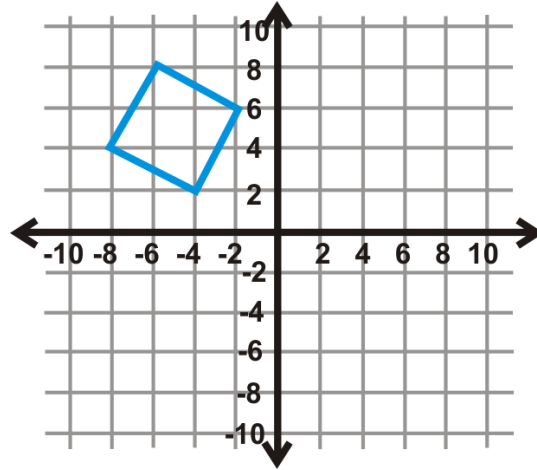

4. Perform a glide reflection over the x -axis and to the right 6 units. Write the new coordinates.
5. What is the rule for this glide reflection?
6. What glide reflection would move the image back to the preimage?

Use the graph of the square to the left to answer questions 7-9.

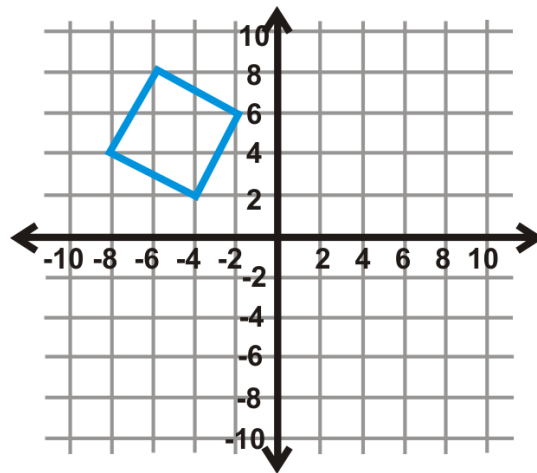

7. Perform a glide reflection to the right 6 units, then over the x -axis. Write the new coordinates.
8. What is the rule for this glide reflection?
9. Is the rule in #8 different than the rule in #5? Why or why not?

Use the graph of the triangle to the left to answer questions 10-12.

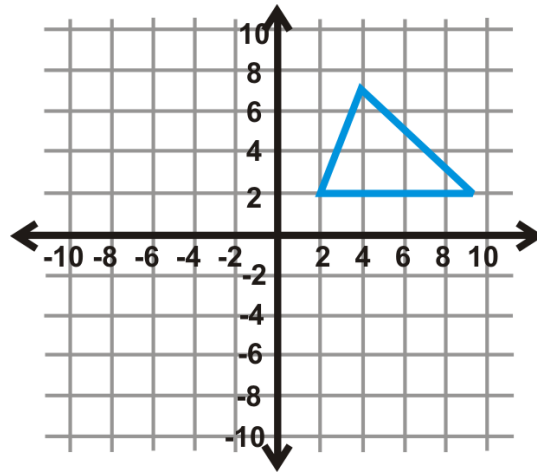

10. Perform a glide reflection over the y -axis and down 5 units. Write the new coordinates.
11. What is the rule for this glide reflection?
12. What glide reflection would move the image back to the preimage?

Use the graph of the triangle to the left to answer questions 13-15.

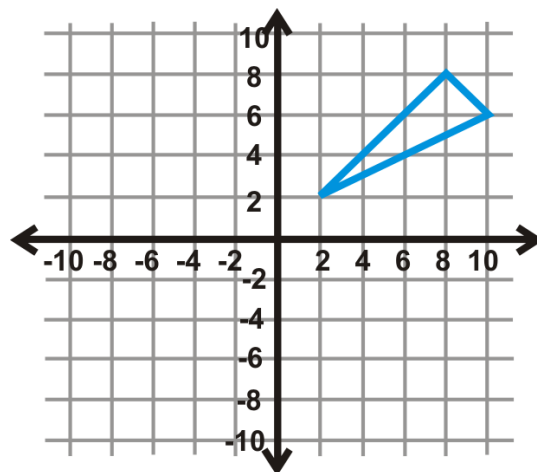

13. Reflect the preimage over $y = -1$ followed by $y = -7$. Draw the new triangle.
14. What one transformation is this double reflection the same as?
15. Write the rule.

Use the graph of the triangle to the left to answer questions 16-18.

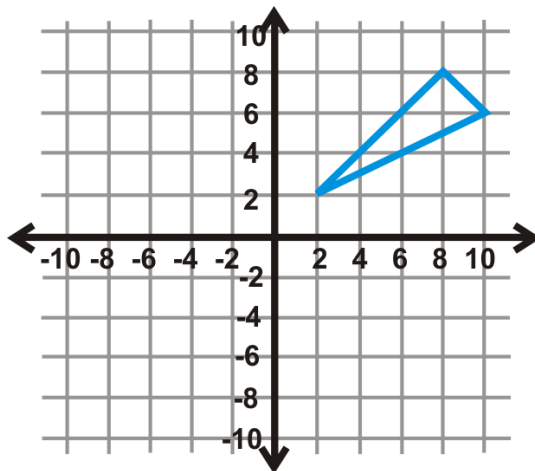

16. Reflect the preimage over $y = -7$ followed by $y = -1$. Draw the new triangle.
17. What one transformation is this double reflection the same as?
18. Write the rule.
19. How do the final triangles in #13 and #16 differ?

Use the trapezoid in the graph to the left to answer questions 20-22.

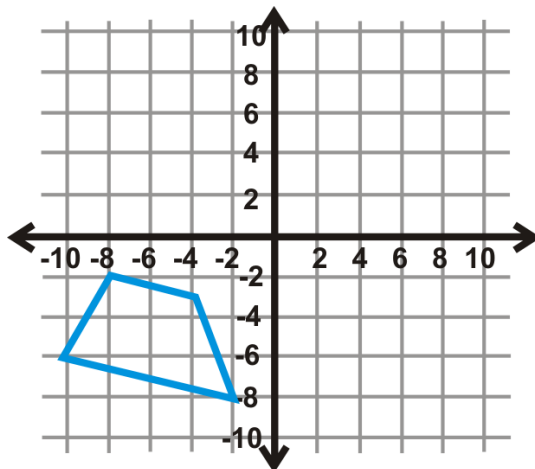

20. Reflect the preimage over the x -axis then the y -axis. Draw the new trapezoid.
21. Now, start over. Reflect the trapezoid over the y -axis then the x -axis. Draw this trapezoid.
22. Are the final trapezoids from #20 and #21 different? Why do you think that is?

Answer the questions below. Be as specific as you can.

23. Two parallel lines are 7 units apart. If you reflect a figure over both how far apart with the preimage and final image be?
24. After a double reflection over parallel lines, a preimage and its image are 28 units apart. How far apart are the parallel lines?
25. Two lines intersect at a 165° angle. If a figure is reflected over both lines, how far apart will the preimage and image be?
26. What is the center of rotation for #25?
27. Two lines intersect at an 83° angle. If a figure is reflected over both lines, how far apart will the preimage and image be?

28. A preimage and its image are 244° apart. If the preimage was reflected over two intersecting lines, at what angle did they intersect?
29. A preimage and its image are 98° apart. If the preimage was reflected over two intersecting lines, at what angle did they intersect?
30. After a double reflection over parallel lines, a preimage and its image are 62 units apart. How far apart are the parallel lines?

12.7 Tessellations

Here you'll learn what a tessellation is and how to tell whether or not a regular polygon can tessellate.

What if you were given a hexagon and asked to tile it over a plane such that it would fill the plane with no overlaps and no gaps? Could you do this? After completing this Concept, you'll be able to determine if a figure tessellates.

Watch This



MEDIA

Click image to the left for more content.

[Tessellations CK-12](#)

Guidance

A **tessellation** is a tiling over a plane with one or more figures such that the figures fill the plane with no overlaps and no gaps. You have probably seen tessellations before. Examples of a tessellation are: a tile floor, a brick or block wall, a checker or chess board, and a fabric pattern. The following pictures are also examples of tessellations.

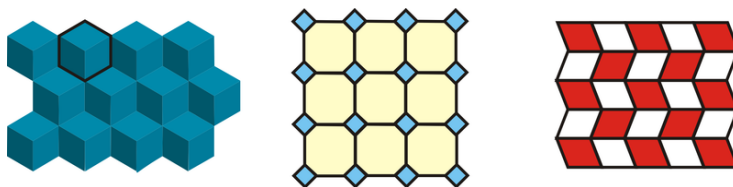

Notice the hexagon (cubes, first tessellation) and the quadrilaterals fit together perfectly. If we keep adding more, they will entirely cover the plane with no gaps or overlaps.

We are only going to worry about tessellating regular polygons. To tessellate a shape, it must be able to exactly surround a point, or the sum of the angles around each point in a tessellation must be 360° . The only regular polygons with this feature are equilateral triangles, squares, and regular hexagons.

Example A

Draw a tessellation of equilateral triangles.

In an equilateral triangle each angle is 60° . Therefore, six triangles will perfectly fit around each point.

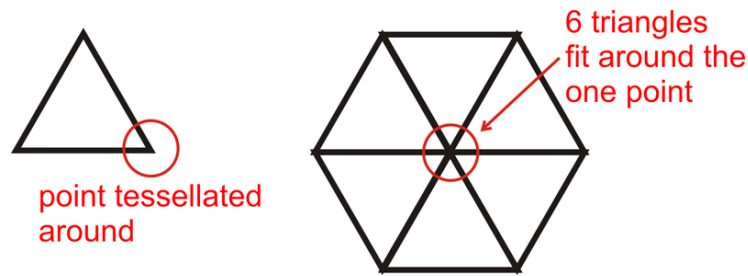

Extending the pattern, we have:

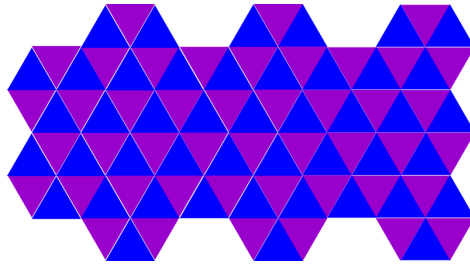

Example B

Does a regular pentagon tessellate?

First, recall that there are 540° in a pentagon. Each angle in a regular pentagon is $540^\circ \div 5 = 108^\circ$. From this, we know that a regular pentagon will not tessellate by itself because 108° times 2 or 3 does not equal 360° .

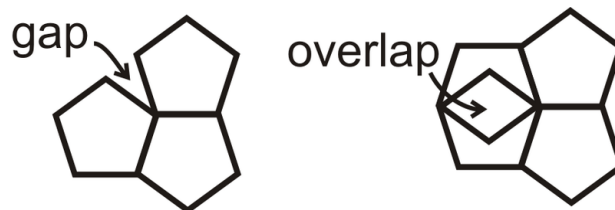

Example C

How many squares will fit around one point?

First, recall how many degrees are in a circle, and then figure out how many degrees are in each angle of a square. There are 360° in a circle and 90° in each interior angle of a square, so $\frac{360}{90} = 4$ squares will fit around one point.



MEDIA

Click image to the left for more content.

Guided Practice

1. How many regular hexagons will fit around one point?
2. Does a regular octagon tessellate?
3. Tessellations can also be much more complicated. Check out <http://www.mathsisfun.com/geometry/tessellation.html> to see other tessellations and play with the Tessellation Artist, which has a link at the bottom of the page.

Answers:

1. First, recall how many degrees are in a circle, and then figure out how many degrees are in each angle of a regular hexagon. There are 360° in a circle and 120° in each interior angle of a hexagon, so $\frac{360}{120} = 3$ hexagons will fit around one point.
2. First, recall that there are 1080° in a pentagon. Each angle in a regular pentagon is $1080^\circ \div 8 = 135^\circ$. From this, we know that a regular octagon will not tessellate by itself because 135° does not go evenly into 360° .

Practice

1. Tessellate a square. Add color to your design.
2. What is an example of a tessellated square in real life?
3. Tessellate a regular hexagon. Add color to your design.
4. You can also tessellate two regular polygons together. Try tessellating a regular hexagon and an equilateral triangle. First, determine how many of each fit around a point and then repeat the pattern. Add color to your design.
5. Does a regular dodecagon (12-sided shape) tessellate? Why or why not?
6. Does a kite tessellate? Why or why not?

Do the following figures tessellate?

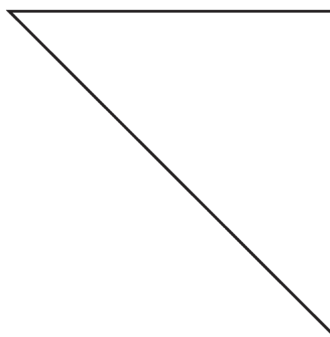

7.

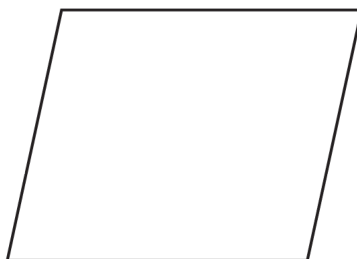

8.

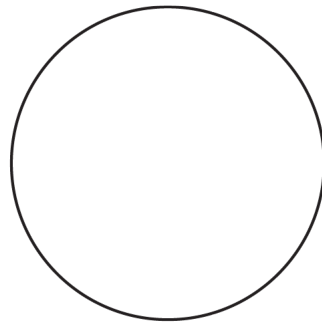

9.

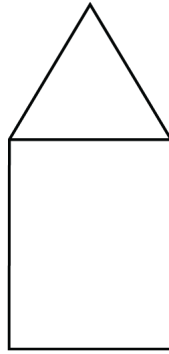

10.

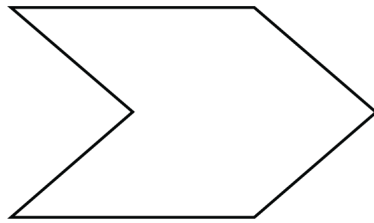

11.

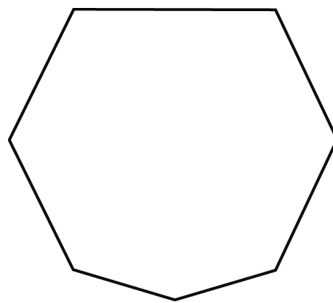

12.

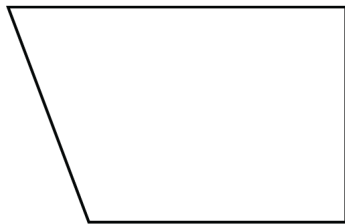

13.

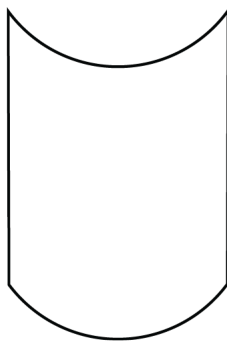

14.

Summary

This chapter discusses transformations of figures in the two-dimensional space. It begins with an explanation of reflection and rotation symmetry. The chapter then branches out to discuss the different types of transformations: translation (sliding a figure to a new position), rotation (rotating a figure with respect to an axis), and reflection (flipping a figure along a line of symmetry). Now that the different types of basic transformations are discussed, the composition of these actions to create a new type of transformation is explored. The chapter wraps up with a detailed presentation of tessellations and regular polygons.