

ck-12

flexbook
next generation textbooks

CK-12 Geometry Concepts



CK-12 Geometry Concepts

Kathryn Dirga
Lori Jordan
Bill Zahner
Jim Sconyers
Victor Cifarelli

Say Thanks to the Authors

Click <http://www.ck12.org/saythanks>

(No sign in required)

To access a customizable version of this book, as well as other interactive content, visit www.ck12.org

CK-12 Foundation is a non-profit organization with a mission to reduce the cost of textbook materials for the K-12 market both in the U.S. and worldwide. Using an open-content, web-based collaborative model termed the **FlexBook®**, CK-12 intends to pioneer the generation and distribution of high-quality educational content that will serve both as core text as well as provide an adaptive environment for learning, powered through the **FlexBook Platform®**.

Copyright © 2013 CK-12 Foundation, www.ck12.org

The names “CK-12” and “CK12” and associated logos and the terms “**FlexBook®**” and “**FlexBook Platform®**” (collectively “CK-12 Marks”) are trademarks and service marks of CK-12 Foundation and are protected by federal, state, and international laws.

Any form of reproduction of this book in any format or medium, in whole or in sections must include the referral attribution link <http://www.ck12.org/saythanks> (placed in a visible location) in addition to the following terms.

Except as otherwise noted, all CK-12 Content (including CK-12 Curriculum Material) is made available to Users in accordance with the Creative Commons Attribution/Non-Commercial/Share Alike 3.0 Unported (CC BY-NC-SA) License (<http://creativecommons.org/licenses/by-nc-sa/3.0/>), as amended and updated by Creative Commons from time to time (the “CC License”), which is incorporated herein by this reference.

Complete terms can be found at <http://www.ck12.org/terms>.

Printed: August 9, 2013

flexbook
next generation textbooks



AUTHORS

Kathryn Dirga
Lori Jordan
Bill Zahner
Jim Sconyers
Victor Cifarelli

Contents

| | | |
|----------|---|------------|
| 1 | Basics of Geometry | 1 |
| 1.1 | Basic Geometric Definitions | 2 |
| 1.2 | Distance Between Two Points | 9 |
| 1.3 | Congruent Angles and Angle Bisectors | 16 |
| 1.4 | Midpoints and Segment Bisectors | 22 |
| 1.5 | Angle Measurement | 29 |
| 1.6 | Angle Classification | 37 |
| 1.7 | Complementary Angles | 42 |
| 1.8 | Supplementary Angles | 46 |
| 1.9 | Linear Pairs | 50 |
| 1.10 | Vertical Angles | 55 |
| 1.11 | Triangle Classification | 61 |
| 1.12 | Polygon Classification | 67 |
| 2 | Reasoning and Proof | 76 |
| 2.1 | Conjectures and Counterexamples | 77 |
| 2.2 | If-Then Statements | 81 |
| 2.3 | Converse, Inverse, and Contrapositive | 85 |
| 2.4 | Inductive Reasoning from Patterns | 90 |
| 2.5 | Deductive Reasoning | 96 |
| 2.6 | Truth Tables | 102 |
| 2.7 | Properties of Equality and Congruence | 109 |
| 2.8 | Two-Column Proofs | 113 |
| 3 | Parallel and Perpendicular Lines | 122 |
| 3.1 | Parallel and Skew Lines | 123 |
| 3.2 | Perpendicular Lines | 128 |
| 3.3 | Corresponding Angles | 138 |
| 3.4 | Alternate Interior Angles | 145 |
| 3.5 | Alternate Exterior Angles | 152 |
| 3.6 | Same Side Interior Angles | 157 |
| 3.7 | Slope in the Coordinate Plane | 163 |
| 3.8 | Parallel Lines in the Coordinate Plane | 167 |
| 3.9 | Perpendicular Lines in the Coordinate Plane | 174 |
| 3.10 | Distance Formula in the Coordinate Plane | 181 |
| 3.11 | Distance Between Parallel Lines | 186 |
| 4 | Triangles and Congruence | 194 |
| 4.1 | Triangle Sum Theorem | 195 |
| 4.2 | Exterior Angles Theorems | 203 |
| 4.3 | Congruent Triangles | 211 |
| 4.4 | Congruence Statements | 217 |

| | | |
|----------|---|------------|
| 4.5 | Third Angle Theorem | 221 |
| 4.6 | SSS Triangle Congruence | 227 |
| 4.7 | SAS Triangle Congruence | 237 |
| 4.8 | ASA and AAS Triangle Congruence | 245 |
| 4.9 | HL Triangle Congruence | 254 |
| 4.10 | Isosceles Triangles | 260 |
| 4.11 | Equilateral Triangles | 268 |
| 5 | Relationships with Triangles | 280 |
| 5.1 | Midsegment Theorem | 281 |
| 5.2 | Perpendicular Bisectors | 289 |
| 5.3 | Angle Bisectors in Triangles | 297 |
| 5.4 | Medians | 306 |
| 5.5 | Altitudes | 314 |
| 5.6 | Comparing Angles and Sides in Triangles | 321 |
| 5.7 | Triangle Inequality Theorem | 329 |
| 5.8 | Indirect Proof in Algebra and Geometry | 332 |
| 6 | Polygons and Quadrilaterals | 337 |
| 6.1 | Interior Angles in Convex Polygons | 338 |
| 6.2 | Exterior Angles in Convex Polygons | 344 |
| 6.3 | Parallelograms | 349 |
| 6.4 | Quadrilaterals that are Parallelograms | 357 |
| 6.5 | Parallelogram Classification | 365 |
| 6.6 | Trapezoids | 374 |
| 6.7 | Kites | 381 |
| 6.8 | Quadrilateral Classification | 388 |
| 7 | Similarity | 396 |
| 7.1 | Forms of Ratios | 397 |
| 7.2 | Proportion Properties | 401 |
| 7.3 | Similar Polygons and Scale Factors | 407 |
| 7.4 | AA Similarity | 414 |
| 7.5 | Indirect Measurement | 420 |
| 7.6 | SSS Similarity | 425 |
| 7.7 | SAS Similarity | 431 |
| 7.8 | Triangle Proportionality | 439 |
| 7.9 | Parallel Lines and Transversals | 445 |
| 7.10 | Proportions with Angle Bisectors | 452 |
| 7.11 | Dilation | 462 |
| 7.12 | Dilation in the Coordinate Plane | 468 |
| 7.13 | Self-Similarity | 473 |
| 8 | Right Triangle Trigonometry | 479 |
| 8.1 | Pythagorean Theorem and Pythagorean Triples | 480 |
| 8.2 | Applications of the Pythagorean Theorem | 488 |
| 8.3 | Inscribed Similar Triangles | 497 |
| 8.4 | 45-45-90 Right Triangles | 505 |
| 8.5 | 30-60-90 Right Triangles | 511 |
| 8.6 | Sine, Cosine, Tangent | 518 |
| 8.7 | Trigonometric Ratios with a Calculator | 524 |
| 8.8 | Trigonometry Word Problems | 529 |

| | | |
|-----------|---|------------|
| 8.9 | Inverse Trigonometric Ratios | 535 |
| 8.10 | Laws of Sines and Cosines | 543 |
| 9 | Circles | 553 |
| 9.1 | Parts of Circles | 554 |
| 9.2 | Tangent Lines | 560 |
| 9.3 | Arcs in Circles | 569 |
| 9.4 | Chords in Circles | 577 |
| 9.5 | Inscribed Angles in Circles | 587 |
| 9.6 | Inscribed Quadrilaterals in Circles | 594 |
| 9.7 | Angles On and Inside a Circle | 600 |
| 9.8 | Angles Outside a Circle | 608 |
| 9.9 | Segments from Chords | 615 |
| 9.10 | Segments from Secants | 623 |
| 9.11 | Segments from Secants and Tangents | 632 |
| 9.12 | Circles in the Coordinate Plane | 642 |
| 10 | Perimeter and Area | 650 |
| 10.1 | Area and Perimeter of Rectangles | 651 |
| 10.2 | Area of a Parallelogram | 655 |
| 10.3 | Area and Perimeter of Triangles | 661 |
| 10.4 | Area of Composite Shapes | 665 |
| 10.5 | Area and Perimeter of Trapezoids | 672 |
| 10.6 | Area and Perimeter of Rhombuses and Kites | 678 |
| 10.7 | Area and Perimeter of Similar Polygons | 687 |
| 10.8 | Circumference | 691 |
| 10.9 | Arc Length | 696 |
| 10.10 | Area of a Circle | 703 |
| 10.11 | Area of Sectors and Segments | 708 |
| 10.12 | Area of Regular Polygons | 715 |
| 11 | Surface Area and Volume | 725 |
| 11.1 | Polyhedrons | 726 |
| 11.2 | Cross-Sections and Nets | 732 |
| 11.3 | Prisms | 738 |
| 11.4 | Cylinders | 747 |
| 11.5 | Pyramids | 753 |
| 11.6 | Cones | 762 |
| 11.7 | Spheres | 770 |
| 11.8 | Composite Solids | 776 |
| 11.9 | Area and Volume of Similar Solids | 782 |
| 12 | Rigid Transformations | 790 |
| 12.1 | Reflection Symmetry | 791 |
| 12.2 | Rotation Symmetry | 797 |
| 12.3 | Geometric Translations | 802 |
| 12.4 | Rotations | 809 |
| 12.5 | Reflections | 820 |
| 12.6 | Composition of Transformations | 829 |
| 12.7 | Tessellations | 837 |
| | | 843 |

CHAPTER

1**Basics of Geometry****Chapter Outline**

- 1.1 BASIC GEOMETRIC DEFINITIONS**
 - 1.2 DISTANCE BETWEEN TWO POINTS**
 - 1.3 CONGRUENT ANGLES AND ANGLE BISECTORS**
 - 1.4 MIDPOINTS AND SEGMENT BISECTORS**
 - 1.5 ANGLE MEASUREMENT**
 - 1.6 ANGLE CLASSIFICATION**
 - 1.7 COMPLEMENTARY ANGLES**
 - 1.8 SUPPLEMENTARY ANGLES**
 - 1.9 LINEAR PAIRS**
 - 1.10 VERTICAL ANGLES**
 - 1.11 TRIANGLE CLASSIFICATION**
 - 1.12 POLYGON CLASSIFICATION**
-

Introduction

In this chapter, students will learn about the building blocks of geometry. We will start with the basics: point, line and plane and build upon those terms. From here, students will learn about segments, midpoints, angles, bisectors, angle relationships, and how to classify polygons.

1.1 Basic Geometric Definitions

Here you'll learn the basic geometric definitions and rules you will need to succeed in geometry.

What if you were given a picture of a figure or an object, like a map with cities and roads marked on it? How could you explain that picture geometrically? After completing this Concept, you'll be able to describe such a map using geometric terms.

Watch This



MEDIA

Click image to the left for more content.

[CK-12 Foundation: Chapter 1 Basic Geometric Definitions A](#)

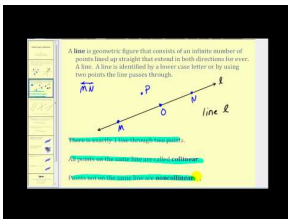

MEDIA

Click image to the left for more content.

[James Sousa: Definitions of and Postulates Involving Points, Lines, and Planes](#)

Guidance

A **point** is an exact location in space. A point describes a location, but has no size. Dots are used to represent points in pictures and diagrams. These points are said "Point A," "Point L", and "Point F." Points are labeled with a CAPITAL letter.



A **line** is a set of infinitely many points that extend forever in both directions. A line, like a point, does not take up space. It has direction, location and is always straight. Lines are one-dimensional because they only have length (no width). A line can be named or identified using any two points on that line or with a lower-case, italicized letter.



This line can be labeled \overleftrightarrow{PQ} , \overleftrightarrow{QP} or just g . You would say “line PQ ,” “line QP ,” or “line g ,” respectively. Notice that the line over the \overleftrightarrow{PQ} and \overleftrightarrow{QP} has arrows over both the P and Q . The order of P and Q does not matter.

A **plane** is infinitely many intersecting lines that extend forever in all directions. Think of a plane as a huge sheet of paper that goes on forever. Planes are considered to be two-dimensional because they have a length and a width. A plane can be classified by any three points in the plane.

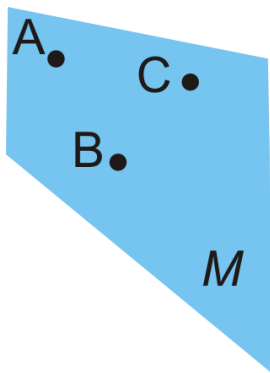

This plane would be labeled Plane ABC or Plane M . Again, the order of the letters does not matter.

We can use **point**, **line**, and **plane** to define new terms. **Space** is the set of all points extending in *three* dimensions. Think back to the plane. It extended along two different lines: up and down, and side to side. If we add a third direction, we have something that looks like three-dimensional space, or the real-world.

Points that lie on the same line are **collinear**. $P, Q, R, S,$ and T are collinear because they are all on line w . If a point U were located above or below line w , it would be **non-collinear**.



Points and/or lines within the same plane are **coplanar**. Lines h and i and points $A, B, C, D, G,$ and K are **coplanar** in Plane j . Line \overleftrightarrow{KF} and point E are **non-coplanar** with Plane j .

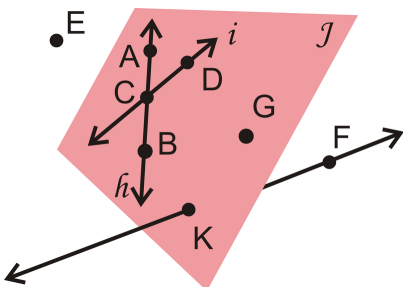

An **endpoint** is a point at the end of a line segment. Line segments are labeled by their endpoints, \overline{AB} or \overline{BA} . Notice that the bar over the endpoints has NO arrows. Order does not matter.



A **ray** is a part of a line with one endpoint that extends forever in the direction opposite that endpoint. A ray is labeled by its endpoint and one other point on the line.



Of lines, line segments and rays, rays are the only one where order matters. When labeling, always write the endpoint under the side WITHOUT the arrow, \overrightarrow{CD} or \overleftarrow{DC} .

An **intersection** is a point or set of points where lines, planes, segments, or rays cross each other.

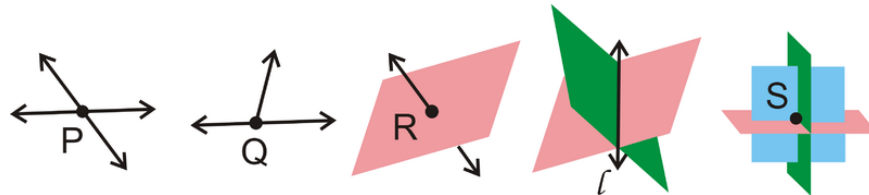

Postulates

With these new definitions, we can make statements and generalizations about these geometric figures. This section introduces a few basic postulates. Throughout this course we will be introducing Postulates and Theorems so it is important that you understand what they are and how they differ.

Postulates are basic rules of geometry. We can assume that all postulates are true, much like a definition. **Theorems** are statements that can be proven true using postulates, definitions, and other theorems that have already been proven.

The only difference between a theorem and postulate is that a postulate is *assumed* true because it cannot be shown to be false, a theorem must be *proven* true. We will prove theorems later in this course.

Postulate #1: Given any two distinct points, there is exactly one (straight) line containing those two points.

Postulate #2: Given any three non-collinear points, there is exactly one plane containing those three points.

Postulate #3: If a line and a plane share two points, then the entire line lies within the plane.

Postulate #4: If two distinct lines intersect, the intersection will be one point.

Postulate #5: If two distinct planes intersect, the intersection will be a line.

When making geometric drawings, be sure to be clear and label all points and lines.

Example A

What best describes San Diego, California on a globe?

- A. point
- B. line
- C. plane

Answer: A city is usually labeled with a dot, or point, on a globe.

Example B

Use the picture below to answer these questions.

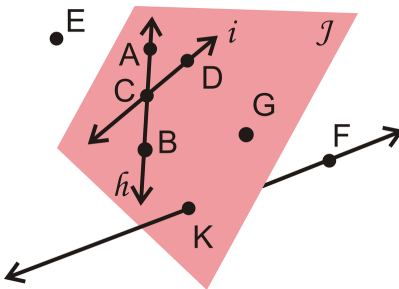

- a) List another way to label Plane j .
- b) List another way to label line h .
- c) Are K and F collinear?
- d) Are E, B and F coplanar?

Answer:

- a) Plane $B DG$. Any combination of three coplanar points that are not collinear would be correct.
- b) \overleftrightarrow{AB} . Any combination of two of the letters A, B , or C would also work.
- c) Yes
- d) Yes

Example C

Describe the picture below using all the geometric terms you have learned.

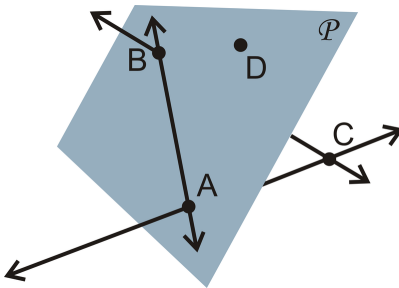

Answer:

\overleftrightarrow{AB} and D are coplanar in Plane P , while \overleftrightarrow{BC} and \overleftrightarrow{AC} intersect at point C which is non-coplanar.

Watch this video for help with the Examples above.



MEDIA
Click image to the left for more content.

Vocabulary

A **point** is an exact location in space. A **line** is infinitely many points that extend forever in both directions. A **plane** is infinitely many intersecting lines that extend forever in all directions. **Space** is the set of all points extending in three dimensions. Points that lie on the same line are **collinear**. Points and/or lines within the same plane are **coplanar**. An **endpoint** is a point at the end of part of a line. A **line segment** is a part of a line with two endpoints. A **ray** is a part of a line with one endpoint that extends forever in the direction opposite that point. An **intersection** is a point or set of points where lines, planes, segments, or rays cross. A **postulate** is a basic rule of geometry is assumed to be true. A **theorem** is a statement that can be proven true using postulates, definitions, and other theorems that have already been proven.

Guided Practice

1. What best describes the surface of a movie screen?

- A. point
- B. line
- C. plane

2. Answer the following questions about the picture.

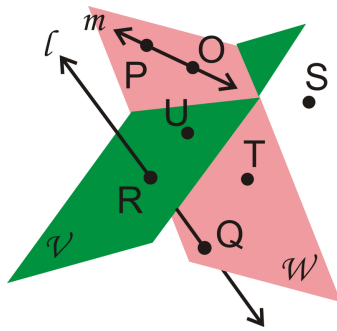

- a) Is line l coplanar with Plane \mathcal{V} , Plane \mathcal{W} , both, or neither?
 - b) Are R and Q collinear?
 - c) What point belongs to neither Plane \mathcal{V} nor Plane \mathcal{W} ?
 - d) List three points in Plane \mathcal{W} .
3. Draw and label the intersection of line \overleftrightarrow{AB} and ray \overrightarrow{CD} at point C .
4. How do the figures below intersect?

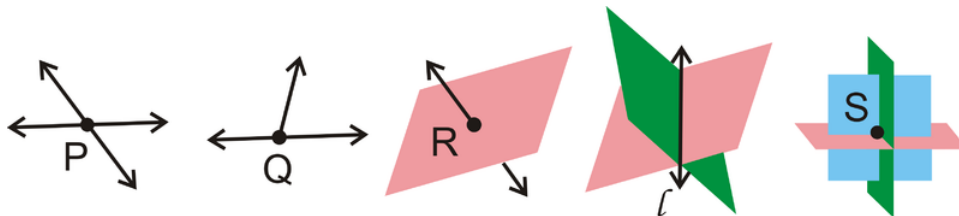

Answers:

1. The surface of a movie screen is most like a plane.

2. a) Neither
 - b) Yes
 - c) S
 - d) Any combination of P, O, T , and Q would work.
3. It does not matter the placement of A or B along the line nor the direction that \overrightarrow{CD} points.

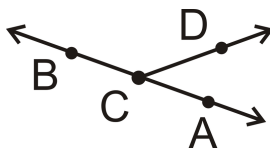

4. The first three figures intersect at a point, P, Q and R , respectively. The fourth figure, two planes, intersect in a line, l . And the last figure, three planes, intersect at one point, S .

Practice

1. Name this line in two ways.

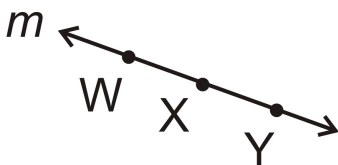

2. Name the geometric figure below in two different ways.

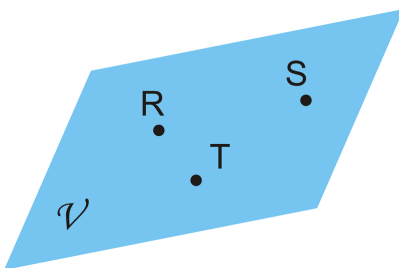

3. Draw three ways three different planes can (or cannot) intersect.
4. What type of geometric object is made by the intersection of a sphere (a ball) and a plane? Draw your answer.

Use geometric notation to explain each picture in as much detail as possible.

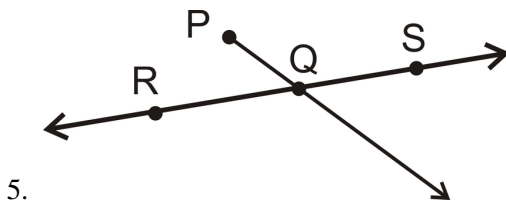

5.

For 6-15, determine if the following statements are ALWAYS true, SOMETIMES true, or NEVER true.

6. Any two distinct points are collinear.
7. Any three points determine a plane.
8. A line is composed of two rays with a common endpoint.
9. A line segment has infinitely many points between two endpoints.
10. A point takes up space.
11. A line is one-dimensional.
12. Any four distinct points are coplanar.
13. \overrightarrow{AB} could be read “ray AB ” or “ray BA .”
14. \overleftrightarrow{AB} could be read “line AB ” or “line BA .”
15. Theorems are proven true with postulates.

In Algebra you plotted points on the coordinate plane and graphed lines. For 16-20, use graph paper and follow the steps to make the diagram on the same graph.

16. Plot the point $(2, -3)$ and label it A .
17. Plot the point $(-4, 3)$ and label it B .
18. Draw the segment \overline{AB} .
19. Locate point C , the intersection of this line with the x -axis.
20. Draw the ray \overrightarrow{CD} with point $D(1, 4)$.

1.2 Distance Between Two Points

Here you'll learn how to measure using a ruler, how to add segments, and how to place line segments on a coordinate grid.

The average adult human body can be measured in "heads." For example, the average human is 7-8 heads tall. When doing this, keep in mind that each person uses their own head to measure their own body. Other interesting measurements are in the picture below.

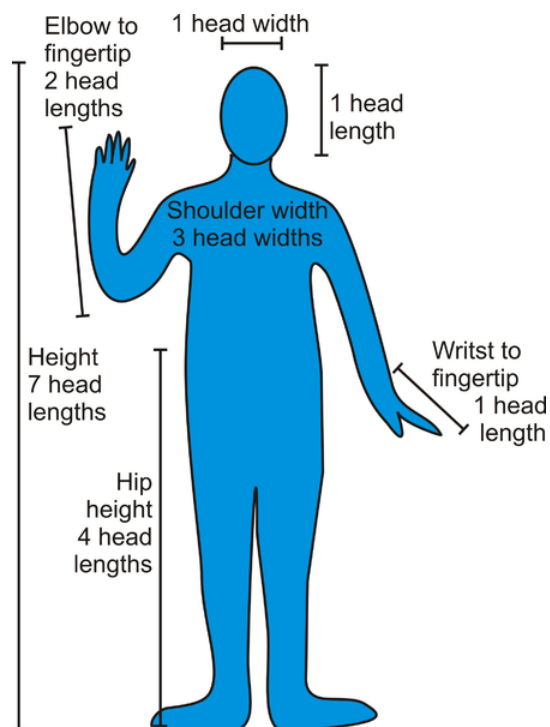

What if you wanted to determine other measurements like the length from the wrist to the elbow or the length from the top of the neck to the hip? After completing this Concept, you will know how to accurately measure using many different units of measurement.

Watch This



MEDIA

Click image to the left for more content.

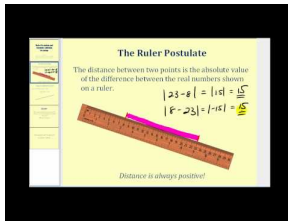

MEDIA

Click image to the left for more content.

James Sousa:Ruler PostulateandSegmentAddition Postulate

Guidance

Distance is the length between two points. To **measure** is to determine how far apart two geometric objects are. Inch-rulers are usually divided up by $\frac{1}{8}$ -in. (or 0.125 in) segments. Centimeter rulers are divided up by $\frac{1}{10}$ -centimeter (or 0.1 cm) segments.

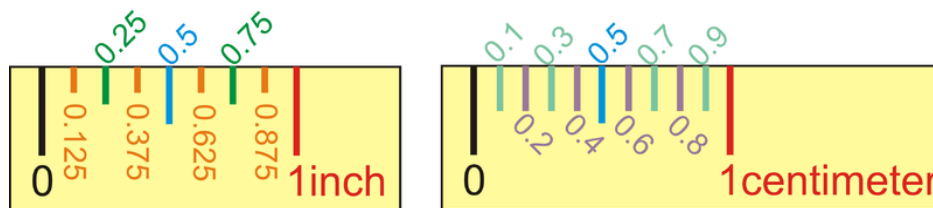

The two rulers above are NOT DRAWN TO SCALE. Anytime you see this statement, it means that the measured length is not actually the distance apart that it is labeled. You should never assume that objects are drawn to scale. Always rely on the measurements or markings given in a diagram.

The **Ruler Postulate** states that the distance between two points will be the absolute value of the difference between the numbers shown on the ruler. The ruler postulate implies that you do not need to start measuring at “0”, as long as you subtract the first number from the second. “Absolute value” is used because **distance is always positive**.

Before we introduce the next postulate, we need to address what the word “between” means in geometry.



B is between A and C in this picture. As long as B is **anywhere on the segment**, it can be considered to be **between** the endpoints.

The **Segment Addition Postulate** states that if A , B , and C are collinear and B is between A and C , then $AB + BC = AC$.

The picture above illustrates the Segment Addition Postulate. If $AB = 5$ cm and $BC = 12$ cm, then AC must equal $5 + 12$ or 17 cm. You may also think of this as the “sum of the partial lengths, will be equal to the whole length.”

In Algebra, you worked with graphing lines and plotting points in the $x - y$ plane. At this point, you can find the distances between points plotted in the $x - y$ plane if the lines are horizontal or vertical. **If the line is vertical, find the change in the y -coordinates. If the line is horizontal, find the change in the x -coordinates.**

Example A

What is the distance marked on the ruler below? The ruler is in centimeters.

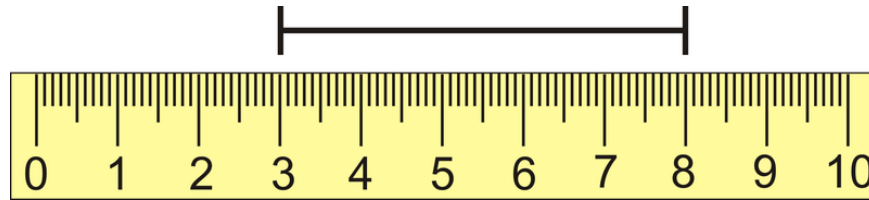

Find the absolute value of difference between the numbers shown. The line segment spans from 3 cm to 8 cm.

$$|8 - 3| = |5| = 5$$

The line segment is 5 cm long. Notice that you also could have done $|3 - 8| = |-5| = 5$.

Example B

Make a sketch of \overline{OP} , where Q is between O and P .

Draw \overline{OP} first, then place Q somewhere along the segment.



Example C

What is the distance between the two points shown below?

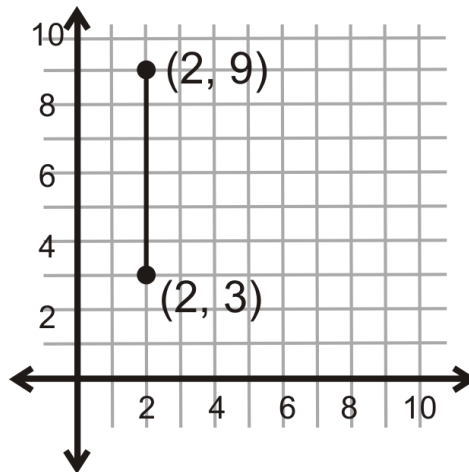

Because this line is vertical, look at the change in the y-coordinates.

$$|9 - 3| = |6| = 6$$

The distance between the two points is 6 units.

Watch this video for help with the Examples above.

MEDIA

Click image to the left for more content.

CK-12 Foundation: Chapter 1 Distance Between Two Points B

Vocabulary

Distance is the length between two points. To **measure** is to determine how far apart two geometric objects are.

Guided Practice

1. Draw \overline{CD} , such that $CD = 3.825$ in.
2. If $OP = 17$ and $QP = 6$, what is OQ ?

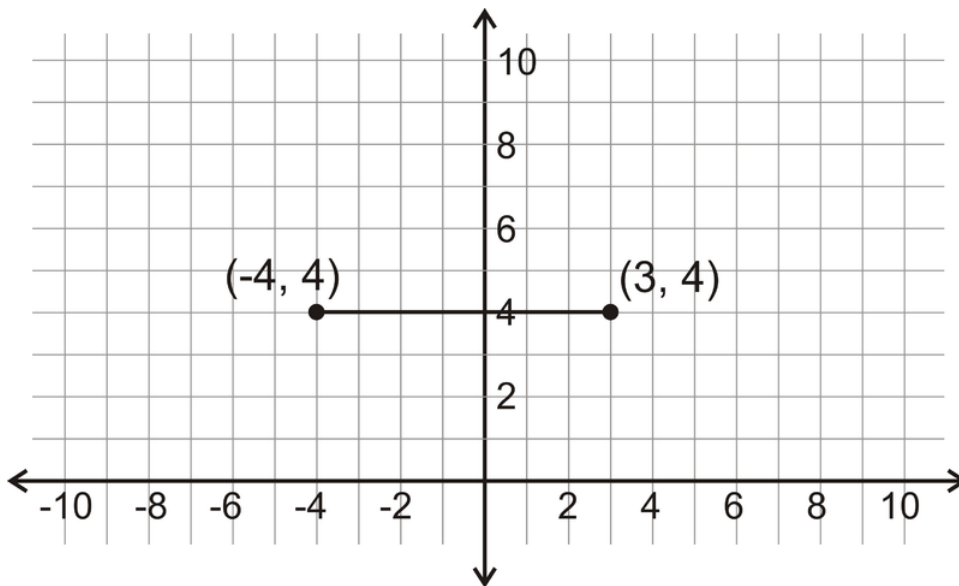

3. Make a sketch that matches the description: S is between T and V . R is between S and T . $TR = 6$ cm, $RV = 23$ cm, and $TR = SV$. Then, find SV , TS , RS and TV .
4. For \overline{HK} , suppose that J is between H and K . If $HJ = 2x + 4$, $JK = 3x + 3$, and $KH = 22$, find the lengths of HJ and JK .
5. What is the distance between the two points shown below?

Answers:

1. To draw a line segment, start at "0" and draw a segment to 3.825 in. Put points at each end and label.



- Use the Segment Addition Postulate. $OQ + QP = OP$, so $OQ + 6 = 17$, or $OQ = 17 - 6 = 11$. So, $OQ = 11$.
- Interpret the first sentence first: S is between T and V .



Then add in what we know about R : It is between S and T .



To find SV , we know it is equal to TR , so $SV = 6$ cm.

$$\underline{\text{For } RS} : RV = RS + SV$$

$$23 = RS + 6$$

$$RS = 17 \text{ cm}$$

$$\underline{\text{For } TS} : TS = TR + RS$$

$$TS = 6 + 17$$

$$TS = 23 \text{ cm}$$

$$\underline{\text{For } TV} : TV = TR + RS + SV$$

$$TV = 6 + 17 + 6$$

$$TV = 29 \text{ cm}$$

- Use the Segment Addition Postulate and then substitute what we know.

$$HJ + JK = KH$$

$$(2x + 4) + (3x + 3) = 22$$

$$5x + 7 = 22$$

$$5x = 15$$

$$x = 3$$

So, if $x = 3$, then $HJ = 10$ and $JK = 12$.

- Because this line is horizontal, look at the change in the x -coordinates.

$$|(-4) - 3| = |-7| = 7$$

The distance between the two points is 7 units.

Practice

For 1-4, use the ruler in each picture to determine the length of the line segment.

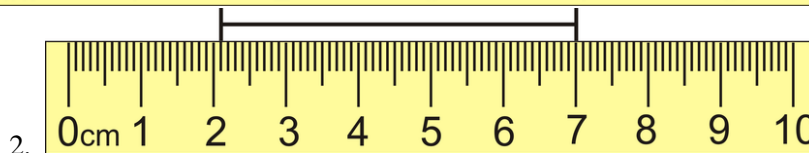
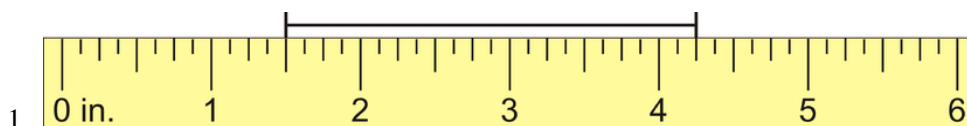

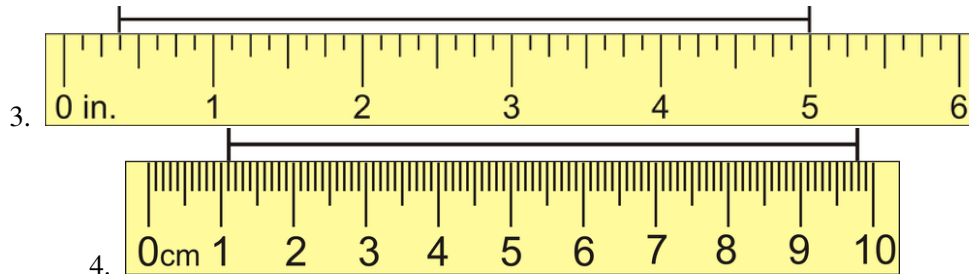

5. Make a sketch of \overline{BT} , with A between B and T .
6. If O is in the middle of \overline{LT} , where exactly is it located? If $LT = 16\text{ cm}$, what is LO and OT ?
7. For three collinear points, A between T and Q .
 - a. Draw a sketch.
 - b. Write the Segment Addition Postulate.
 - c. If $AT = 10\text{ in}$ and $AQ = 5\text{ in}$, what is TQ ?
8. For three collinear points, M between H and A .
 - a. Draw a sketch.
 - b. Write the Segment Addition Postulate.
 - c. If $HM = 18\text{ cm}$ and $HA = 29\text{ cm}$, what is AM ?
9. Make a sketch that matches the description: B is between A and D . C is between B and D . $AB = 7\text{ cm}$, $AC = 15\text{ cm}$, and $AD = 32\text{ cm}$. Find BC , BD , and CD .

For 10-14, Suppose J is between H and K . Use the Segment Addition Postulate to solve for x . Then find the length of each segment.

10. $HJ = 4x + 9$, $JK = 3x + 3$, $KH = 33$
11. $HJ = 5x - 3$, $JK = 8x - 9$, $KH = 131$
12. $HJ = 2x + \frac{1}{3}$, $JK = 5x + \frac{2}{3}$, $KH = 12x - 4$
13. $HJ = x + 10$, $JK = 9x$, $KH = 14x - 58$
14. $HJ = \frac{3}{4}x - 5$, $JK = x - 1$, $KH = 22$
15. Draw four points, A , B , C , and D such that $AB = BC = AC = AD = BD$ (HINT: A , B , C and D should NOT be collinear)

For 16-19, determine the vertical or horizontal distance between the two points.

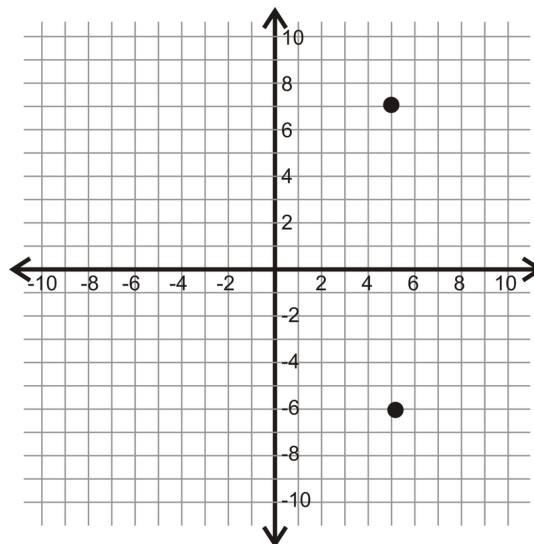

16.

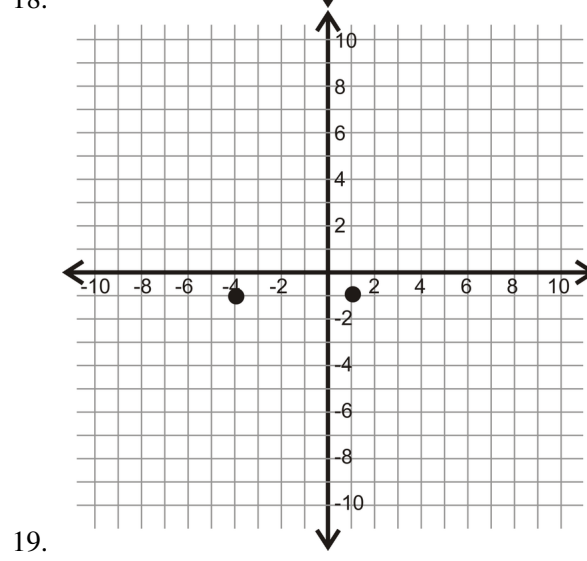
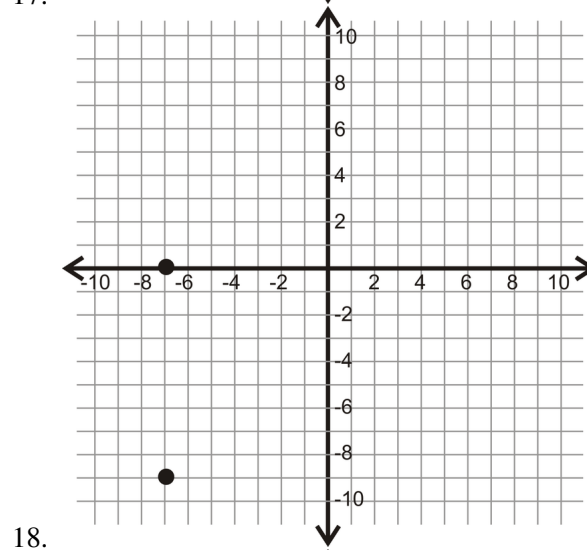
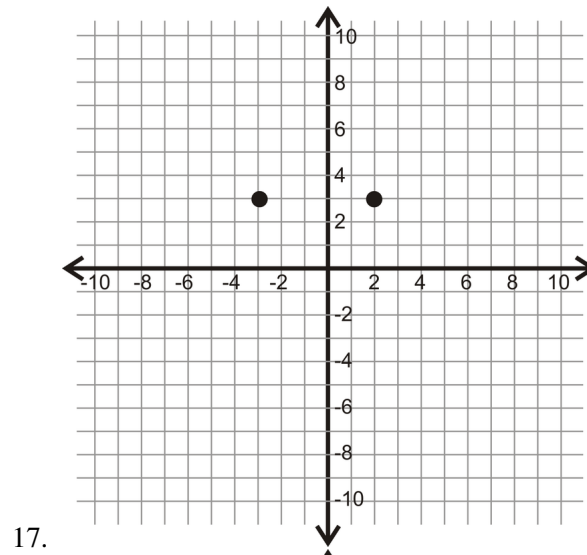

1.3 Congruent Angles and Angle Bisectors

Here you'll learn how to find unknown values using the definitions of angle congruency and angle bisector. You'll also learn how to construct an angle bisector.

What if you knew that an angle was split exactly in half? How could you use this information to help you solve problems? After completing this Concept, you'll be able to bisect an angle and solve problems related to angle bisectors.

Watch This



MEDIA

Click image to the left for more content.

CK-12 Foundation: Chapter 1 Congruent Angles and Angle Bisectors A

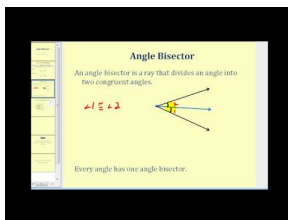

MEDIA

Click image to the left for more content.

James Sousa: Angle Bisectors

Watch the first part of this video.

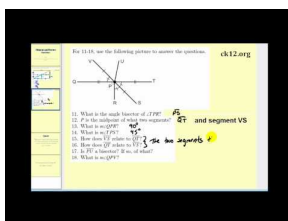

MEDIA

Click image to the left for more content.

James Sousa: Angle Bisector Exercise 2

Guidance

When two rays have the same endpoint, an angle is created.

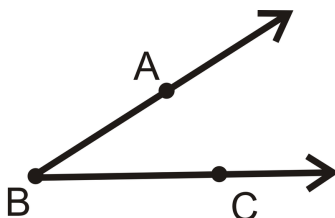

Here, \vec{BA} and \vec{BC} meet to form an angle. An angle is labeled with an “ \angle ” symbol in front of the three letters used to label it. This angle can be labeled $\angle ABC$ or $\angle CBA$. **Always put the vertex (the common endpoint of the two rays) in the middle of the three points.** It doesn’t matter which side point is written first.

An **angle bisector** is a ray that divides an angle into two congruent angles, each having a measure exactly half of the original angle. Every angle has exactly one angle bisector.

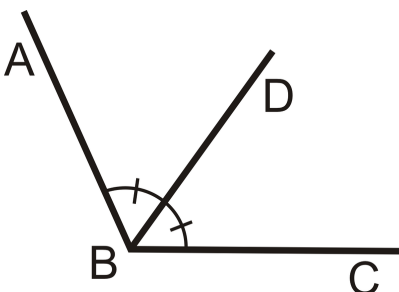

\vec{BD} is the angle bisector of $\angle ABC$

$$\angle ABD \cong \angle DBC$$

$$m\angle ABD = \frac{1}{2}m\angle ABC$$

Label equal angles with **angle markings**, as shown below.

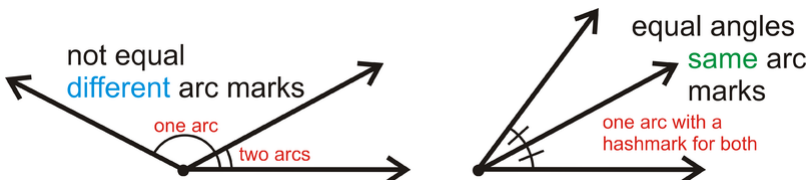

Investigation: Constructing an Angle Bisector

1. Draw an angle on your paper. Make sure one side is horizontal.

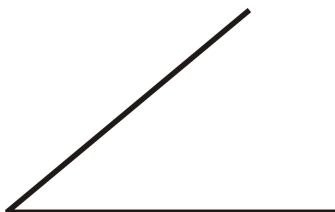

2. Place the pointer on the vertex. Draw an arc that intersects both sides.

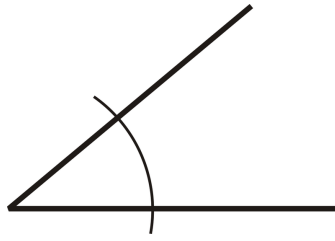

3. Move the pointer to the arc intersection with the horizontal side. Make a second arc mark on the interior of the angle. Repeat on the other side. Make sure they intersect.

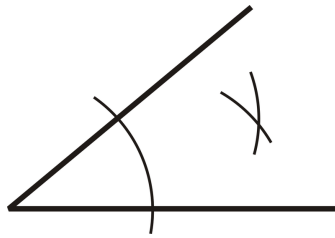

4. Connect the arc intersections from #3 with the vertex of the angle.

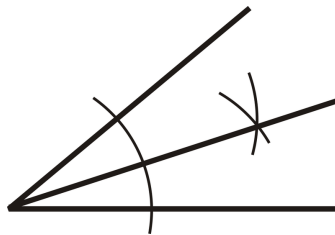

To see an animation of this construction, view <http://www.mathsisfun.com/geometry/construct-anglebisect.html>.

Example A

How many angles are in the picture below? Label each one two different ways.

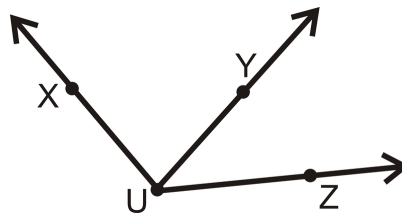

There are three angles with vertex U . It might be easier to see them all if we separate them out.

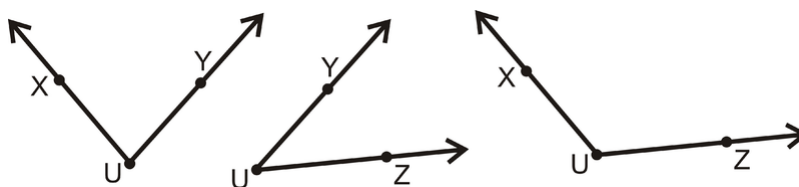

So, the three angles can be labeled, $\angle XUY$ or $\angle YUX$, $\angle YUZ$ or $\angle ZUY$, and $\angle XUZ$ or $\angle ZUX$.

Example B

What is the measure of each angle?

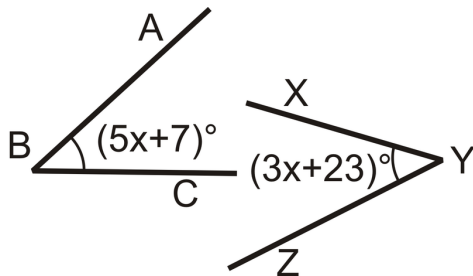

From the picture, we see that the angles are congruent, so the given measures are equal.

$$\begin{aligned}(5x + 7)^\circ &= (3x + 23)^\circ \\ 2x^\circ &= 16^\circ \\ x &= 8^\circ\end{aligned}$$

To find the measure of $\angle ABC$, plug in $x = 8^\circ$ to $(5x + 7)^\circ$.

$$\begin{aligned}(5(8) + 7)^\circ \\ (40 + 7)^\circ \\ 47^\circ\end{aligned}$$

Because $m\angle ABC = m\angle XYZ$, $m\angle XYZ = 47^\circ$ too.

Example C

Is \overline{OP} the angle bisector of $\angle SOT$? If $m\angle ROT = 165^\circ$, what is $m\angle SOP$ and $m\angle POT$?

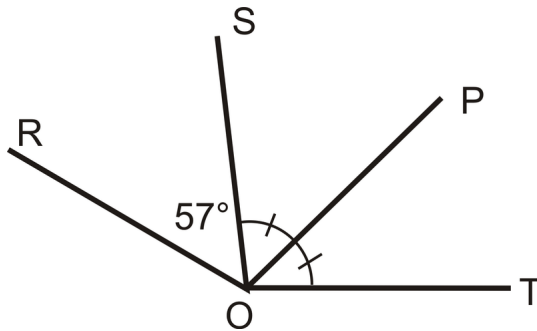

Yes, \overline{OP} is the angle bisector of $\angle SOT$ according to the markings in the picture. If $m\angle ROT = 165^\circ$ and $m\angle ROS = 57^\circ$, then $m\angle SOT = 165^\circ - 57^\circ = 108^\circ$. The $m\angle SOP$ and $m\angle POT$ are each half of 108° or 54° .

Watch this video for help with the Examples above.



MEDIA

Click image to the left for more content.

CK-12 Foundation: Chapter 1 Congruent Angles and Angle Bisectors B

Vocabulary

When two geometric figures have the same shape and size then they are **congruent**. An **angle bisector** is a ray that divides an angle into two congruent angles, each having a measure exactly half of the original angle.

Guided Practice

For exercises 1 and 2, copy the figure below and label it with the following information:

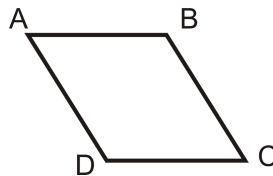

- $\angle A \cong \angle C$
- $\angle B \cong \angle D$
- Use algebra to determine the value of d :

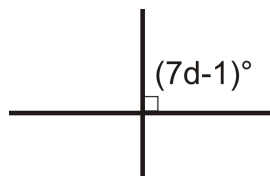

Answers:

- You should have corresponding markings on $\angle A$ and $\angle C$.
- You should have corresponding markings on $\angle B$ and $\angle D$ (that look different from the markings you made in #1).
- The square marking means it is a 90° angle, so the two angles are congruent. Set up an equation and solve:

$$\begin{aligned} 7d - 1 &= 2d + 14 \\ 5d &= 15 \\ d &= 3 \end{aligned}$$

Practice

For 1-4, use the following picture to answer the questions.

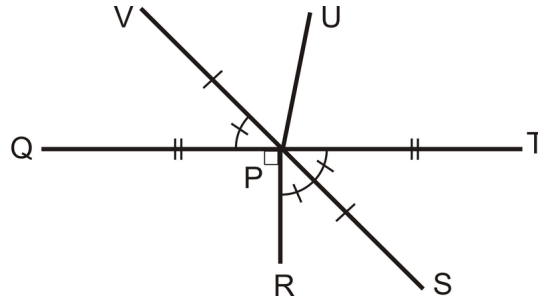

1. What is the angle bisector of $\angle TPR$?
2. What is $m\angle QPR$?
3. What is $m\angle TPS$?
4. What is $m\angle QPV$?

For 5-6, use algebra to determine the value of variable in each problem.

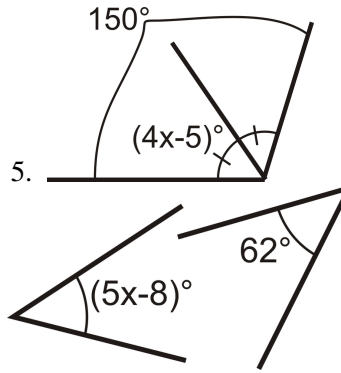

For 7-10, decide if the statement is true or false.

7. Every angle has exactly one angle bisector.
8. Any marking on an angle means that the angle is 90° .
9. An angle bisector divides an angle into three congruent angles.
10. Congruent angles have the same measure.

In Exercises 11-15, use the following information: Q is in the interior of $\angle ROS$. S is in the interior of $\angle QOP$. P is in the interior of $\angle SOT$. S is in the interior of $\angle ROT$ and $m\angle ROT = 160^\circ$, $m\angle SOT = 100^\circ$, and $m\angle ROQ = m\angle QOS = m\angle POT$.

11. Make a sketch.
12. Find $m\angle QOP$
13. Find $m\angle QOT$
14. Find $m\angle ROQ$
15. Find $m\angle SOP$

1.4 Midpoints and Segment Bisectors

Here you'll learn what a midpoint, a segment bisector, and a perpendicular bisector are and how to use their properties to solve for unknown values.

What if you were given the coordinates of two points and you wanted to find the point exactly in the middle of them? How would you find the coordinates of this third point? After completing this Concept, you'll be able to use the Midpoint Formula to find the location of such a point in the coordinate plane, and you'll be able to give specific examples of lines that create midpoints.

Watch This



MEDIA

Click image to the left for more content.

CK-12 Foundation: Chapter 1 Midpoints and Segment Bisectors A

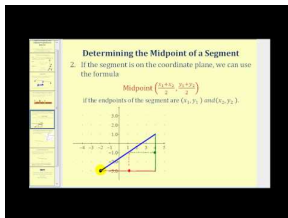

MEDIA

Click image to the left for more content.

James Sousa: Segment Midpoint and Segment Perpendicular Bisector

Then watch the first part of this video.

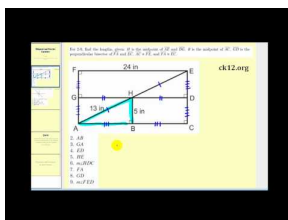

MEDIA

Click image to the left for more content.

James Sousa: Midpoint Exercise 1

Guidance

A **midpoint** is a point on a line segment that divides it into two congruent segments.



MEDIA

Click image to the left for more content.

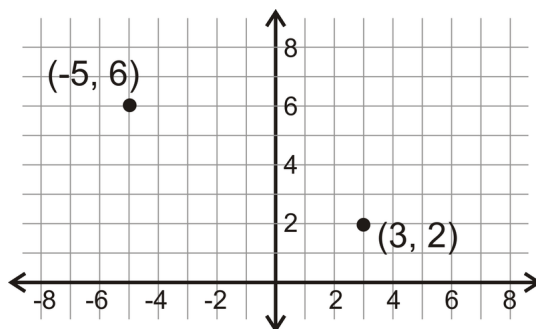
Because $AB = BC$, B is the midpoint of \overline{AC} . Any line segment will have exactly one midpoint. When points are plotted in the coordinate plane, you can use slope to find the midpoint between them. We will generate a formula here.

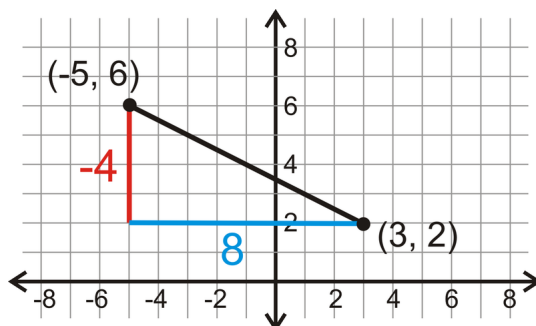

Here are two points, $(-5, 6)$ and $(3, 2)$. Draw a line between the two points and determine the vertical distance and the horizontal distance.



So, it follows that the midpoint is down and over half of each distance. The midpoint would then be down 2 (or -2) from $(-5, 6)$ and over positive 4. If we do that we find that the midpoint is $(-1, 4)$.

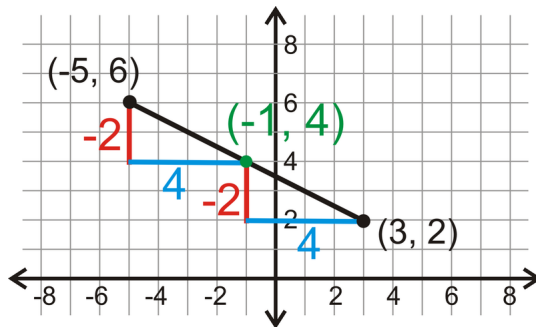

Let's create a formula from this. If the two endpoints are $(-5, 6)$ and $(3, 2)$, then the midpoint is $(-1, 4)$. -1 is *halfway* between -5 and 3 and 4 is *halfway* between 6 and 2 . Therefore, the formula for the midpoint is the average of the x -values and the average of the y -values.

Midpoint Formula: For two points, (x_1, y_1) and (x_2, y_2) , the midpoint is $\left(\frac{x_1+x_2}{2}, \frac{y_1+y_2}{2}\right)$

A line, segment, or ray that passes through a midpoint of another segment is called a **segment bisector**. A bisector cuts a line segment into two congruent parts. A specific type of segment bisector is called a **perpendicular bisector**, when the bisector intersects the segment at a right angle.

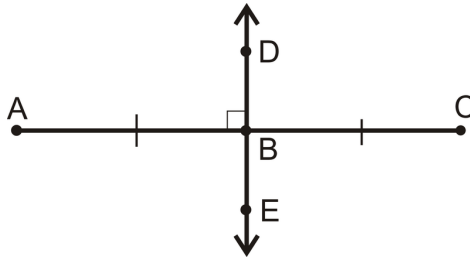

\overleftrightarrow{DE} is the perpendicular bisector of \overline{AC} , so $\overline{AB} \cong \overline{BC}$ and $\overline{AC} \perp \overleftrightarrow{DE}$.

For every line segment, there is one perpendicular bisector that passes through the midpoint. There are *infinitely many bisectors*, but only *one perpendicular bisector* for any segment.

Investigation: Constructing a Perpendicular Bisector

1. Draw a line that is at least 6 cm long, about halfway down your page.



2. Place the pointer of the compass at an endpoint. Open the compass to be greater than half of the segment. Make arc marks above and below the segment. Repeat on the other endpoint. Make sure the arc marks intersect.



3. Use your straight edge to draw a line connecting the arc intersections.

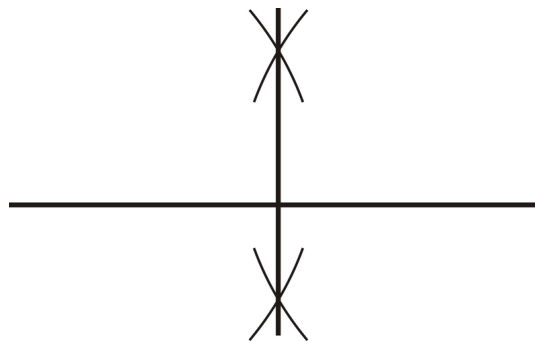

This constructed line bisects the line you drew in #1 and intersects it at 90° . So, this construction also works to create a right angle. To see an animation of this investigation, go to <http://www.mathsisfun.com/geometry/construct-linebisect.html>.

Example A

Is M a midpoint of \overline{AB} ?

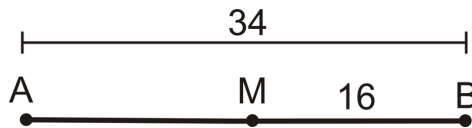

No, it is not because $MB = 16$ and $AM = 34 - 16 = 18$.

Example B

Find the midpoint between $(9, -2)$ and $(-5, 14)$.

Plug the points into the formula.

$$\left(\frac{9 + (-5)}{2}, \frac{-2 + 14}{2} \right) = \left(\frac{4}{2}, \frac{12}{2} \right) = (2, 6)$$

Example C

If $M(3, -1)$ is the midpoint of \overline{AB} and $B(7, -6)$, find A .

Plug what you know into the midpoint formula.

$$\begin{aligned} \left(\frac{7 + x_A}{2}, \frac{-6 + y_A}{2} \right) &= (3, -1) \\ \frac{7 + x_A}{2} &= 3 \text{ and } \frac{-6 + y_A}{2} = -1 && A \text{ is } (-1, 4). \\ 7 + x_A &= 6 \text{ and } -6 + y_A = -2 \\ x_A &= -1 \text{ and } y_A = 4 \end{aligned}$$

Another way to find the other endpoint is to find the difference between M and B and then duplicate it on the other side of M .

x - values: $7 - 3 = 4$, so 4 on the other side of 3 is $3 - 4 = -1$

y - values: $-6 - (-1) = -5$, so -5 on the other side of -1 is $-1 - (-5) = 4$

A is still $(-1, 4)$. You may use either method.

Example D

Use a ruler to draw a bisector of the segment below.



The first step in identifying a bisector is finding the midpoint. Measure the line segment and it is 4 cm long. To find the midpoint, divide 4 by 2.

So, the midpoint will be 2 cm from either endpoint, or halfway between. Measure 2 cm from one endpoint and draw the midpoint.



To finish, draw a line that passes through the midpoint. It doesn't matter how the line intersects \overline{XY} , as long as it passes through Z.

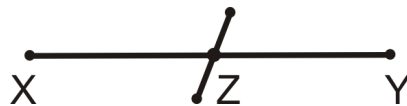

Watch this video for help with the Examples above.



MEDIA

Click image to the left for more content.

[CK-12 Foundation: Chapter1MidpointsandSegmentBisectorsB](#)

Vocabulary

A **midpoint** is a point on a line segment that divides it into two congruent segments. A line, segment, or ray that passes through a midpoint of another segment is called a **segment bisector**. When the bisector intersects the segment at a right angle, it is called a **perpendicular bisector**.

Guided Practice

1. Which line is the perpendicular bisector of \overline{MN} ?

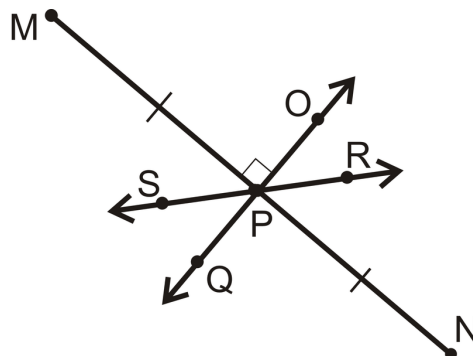

2. Find x and y .

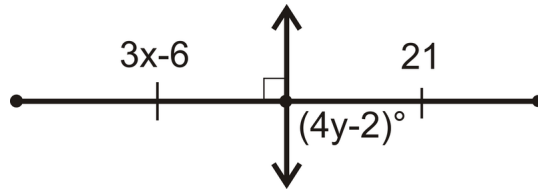

3. Find the midpoint between (3, 7) and (7, 11)

Answers:

1. The perpendicular bisector must bisect \overline{MN} and be perpendicular to it. Only \overleftrightarrow{OQ} satisfies both requirements. \overleftrightarrow{SR} is just a bisector.

2. The line shown is the perpendicular bisector. So, $3x - 6 = 21$, $3x = 27$, $x = 9$. And, $(4y - 2)^\circ = 90^\circ$, $4y^\circ = 92^\circ$, $y = 23^\circ$.

3.

$$\left(\frac{3+7}{2}, \frac{7+11}{2}\right) = \left(\frac{10}{2}, \frac{18}{2}\right) = (5, 9)$$

Practice

1. Copy the figure below and label it with the following information:

- $\angle A \cong \angle C$
- $\angle B \cong \angle D$
- $\overline{AB} \cong \overline{CD}$
- $\overline{AD} \cong \overline{BC}$

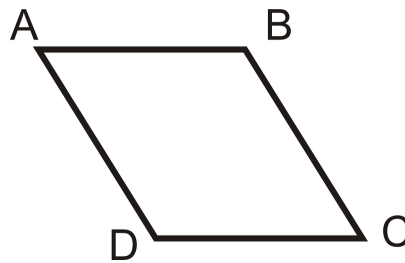

For 2-9, find the lengths, given: H is the midpoint of \overline{AE} and \overline{DG} , B is the midpoint of \overline{AC} , \overline{GD} is the perpendicular bisector of \overline{FA} and \overline{EC} , $\overline{AC} \cong \overline{FE}$, and $\overline{FA} \cong \overline{EC}$.

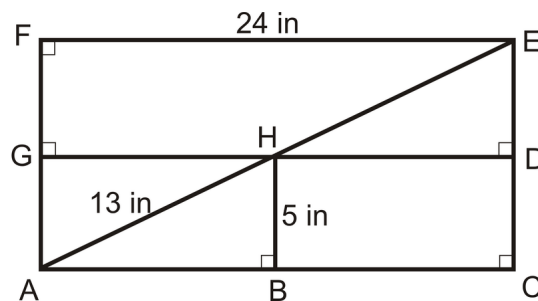

2. AB
3. GA
4. ED
5. HE
6. FA
7. GD
8. How many copies of triangle AHB can fit inside rectangle $FECA$ without overlapping?
9. **Construction** Using your ruler, draw a line segment that is 7 cm long. Then use your compass to construct the perpendicular bisector, What is the measure of each segment?
10. **Construction** Using your ruler, draw a line segment that is 4 in long. Then use your compass to construct the perpendicular bisector, What is the measure of each segment?

For questions 10-13, find the midpoint between each pair of points.

10. $(-2, -3)$ and $(8, -7)$
11. $(9, -1)$ and $(-6, -11)$
12. $(-4, 10)$ and $(14, 0)$
13. $(0, -5)$ and $(-9, 9)$

Given the midpoint (M) and either endpoint of \overline{AB} , find the other endpoint.

14. $A(-1, 2)$ and $M(3, 6)$
15. $B(-10, -7)$ and $M(-2, 1)$
16. **Error Analysis** Erica is looking at a geometric figure and trying to determine which parts are congruent. She wrote $\overline{AB} = \overline{CD}$. Is this correct? Why or why not?
17. **Construction Challenge** Use construction tools and the constructions you have learned in this section to construct two 2 in segments that bisect each other. Now connect all four endpoints with segments. What figure have you constructed?

1.5 Angle Measurement

Here you'll learn how to measure an angle with a protractor and how to apply the Angle Addition Postulate to find unknown values.

What if you needed a way to describe the size of an angle? After completing this Concept, you'll be able to use a protractor to measure an angle in degrees.

Watch This



MEDIA

Click image to the left for more content.

CK-12 Foundation: Chapter 1 Measuring Angles A

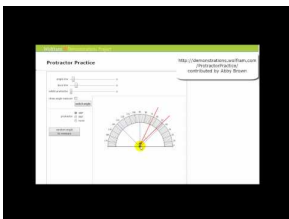

MEDIA

Click image to the left for more content.

James Sousa: Animation of Measuring Angles with a Protractor

Watch the first part of this video.

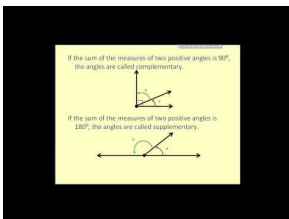

MEDIA

Click image to the left for more content.

James Sousa: Angle Basics

Guidance

We measure a line segment's *length* with a ruler. Angles are measured with something called a **protractor**. A protractor is a measuring device that measures how "open" an angle is. Angles are measured in degrees, and labeled with a $^\circ$ symbol.

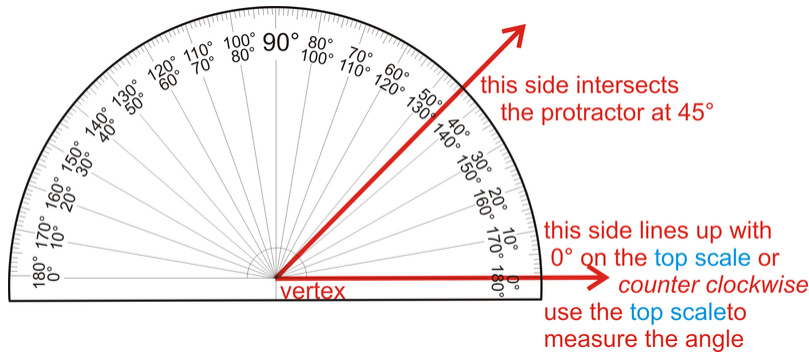

Notice that there are two sets of measurements, one opening clockwise and one opening counter-clockwise, from 0° to 180° . When measuring angles, always line up one side with 0° , and see where the other side hits the protractor. The vertex lines up in the middle of the bottom line, where all the degree lines meet.

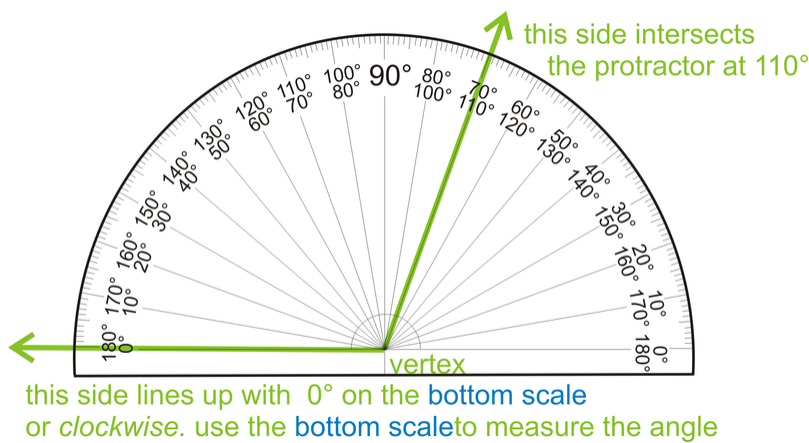

For every angle there is a number between 0° and 180° that is the measure of the angle in degrees. The angle's measure is then the absolute value of the difference of the numbers shown on the protractor where the sides of the angle intersect the protractor. In other words, you do not have to start measuring an angle at 0° , as long as you subtract one measurement from the other.

The **Angle Addition Postulate** states that if B is on the interior of $\angle ADC$, then $m\angle ADC = m\angle ADB + m\angle BDC$. See the picture below.

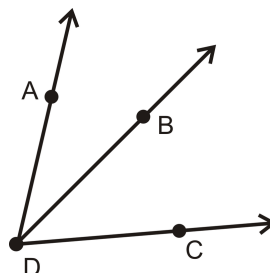

Drawing a 50° Angle with a Protractor

1. Start by drawing a horizontal line across the page, about 2 in long.
2. Place an endpoint at the left side of your line.



- Place the protractor on this point. Make sure to put the center point on the bottom line of the protractor on the vertex. Mark 50° on the appropriate scale.

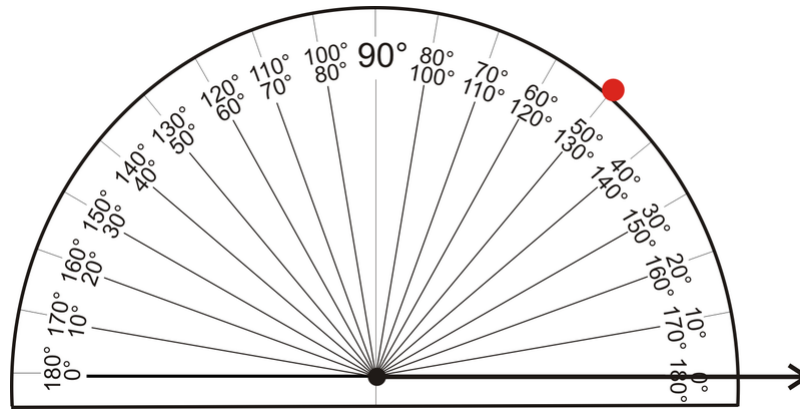

- Remove the protractor and connect the vertex and the 50° mark.

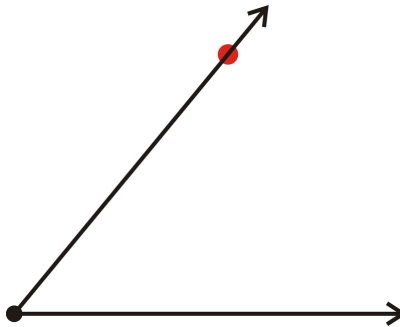

This process can be used to draw any angle between 0° and 180° . See <http://www.mathsisfun.com/geometry/protractor-using.html> for an **animation** of this investigation.

Copying an Angle with a Compass and Straightedge

- We are going to copy the angle created in the previous investigation, a 50° angle. First, draw a straight line, about 2 inches long, and place an endpoint at one end.

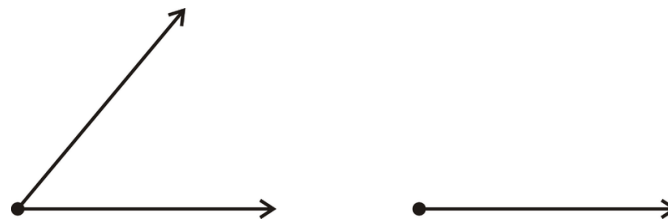

- With the point (non-pencil side) of the compass on the vertex, draw an arc that passes through both sides of the angle. Repeat this arc with the line we drew in #1.

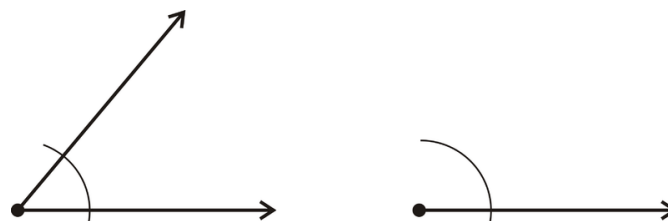

3. Move the point of the compass to the horizontal side of the angle we are copying. Place the point where the arc intersects this side. Open (or close) the “mouth” of the compass so you can draw an arc that intersects the other side of the arc drawn in #2. Repeat this on the line we drew in #1.

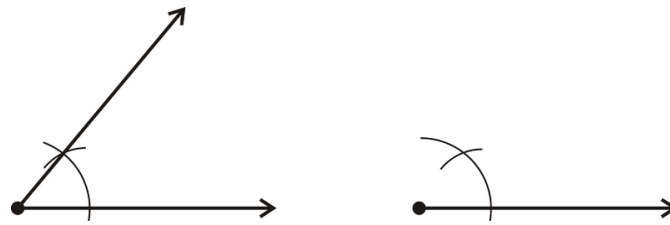

4. Draw a line from the new vertex to the arc intersections.

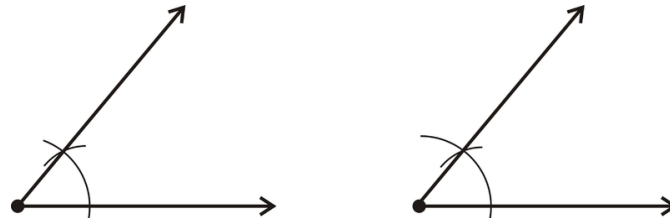

To watch an **animation** of this construction, see <http://www.mathsisfun.com/geometry/construct-anglesame.html>

Example A

Measure the three angles using a protractor.

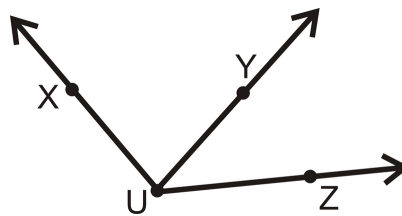

It might be easier to measure these three angles if you separate them. With measurement, we put an m in front of the \angle sign to indicate measure. So, $m\angle XUY = 84^\circ$, $m\angle YUZ = 42^\circ$ and $m\angle XUZ = 126^\circ$.

Example B

What is the measure of the angle shown below?

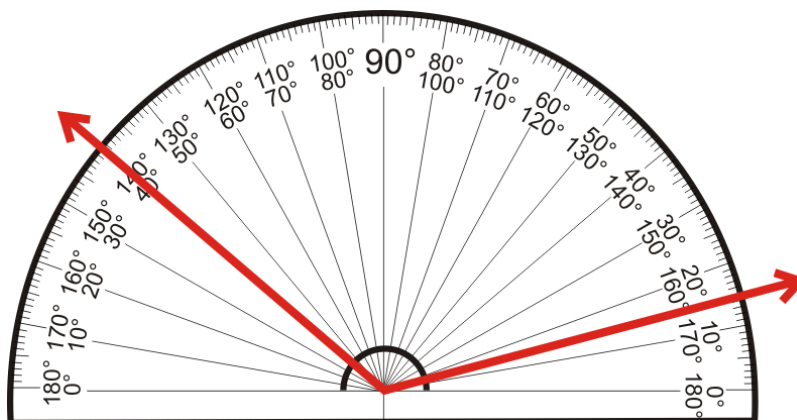

This angle is not lined up with 0° , so use subtraction to find its measure. It does not matter which scale you use.

Using the inner scale, $|140 - 25| = 125^\circ$

Using the outer scale, $|165 - 40| = 125^\circ$

Example C

What is $m\angle QRT$ in the diagram below?

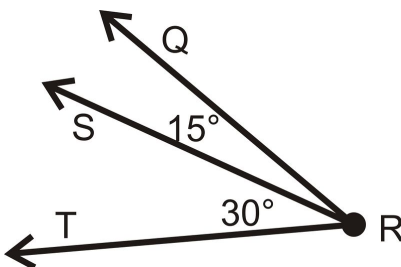

Using the Angle Addition Postulate, $m\angle QRT = 15^\circ + 30^\circ = 45^\circ$.

Example D

Draw a 135° angle.

Following the steps from above, your angle should look like this:

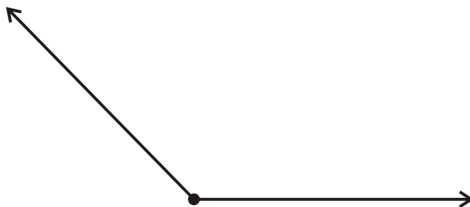

Watch this video for help with the Examples above.



MEDIA

Click image to the left for more content.

[CK-12 Foundation: Chapter1MeasuringAnglesB](#)

Vocabulary

A **protractor** is a measuring device that measures how “open” an angle is. Angles are measured in **degrees**, and labeled with a $^\circ$ symbol. A **compass** is a tool used to draw circles and arcs.

Guided Practice

1. Use a protractor to measure $\angle RST$ below.

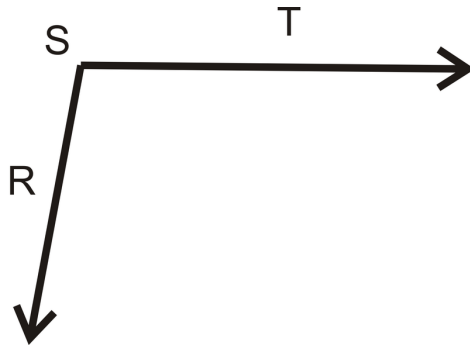

2. What is $m\angle LMN$ if $m\angle LMO = 85^\circ$ and $m\angle NMO = 53^\circ$?

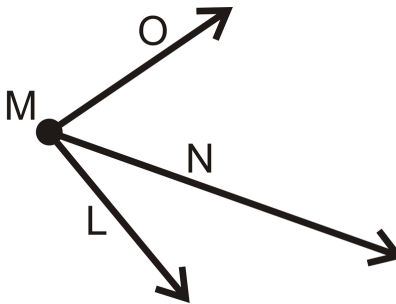

3. If $m\angle ABD = 100^\circ$, find x and $m\angle ABC$ and $m\angle CBD$?

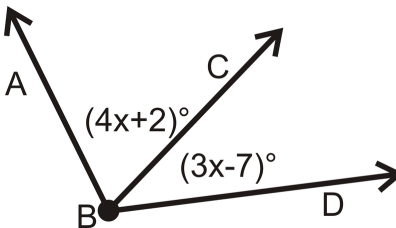

Answers:

1. The easiest way to measure any angle is to line one side up with 0° . This angle measures 100° .
2. From the Angle Addition Postulate, $m\angle LMO = m\angle NMO + m\angle LMN$. Substituting in what we know, $85^\circ = 53^\circ + m\angle LMN$, so $85^\circ - 53^\circ = m\angle LMN$ or $m\angle LMN = 32^\circ$.
3. From the Angle Addition Postulate, $m\angle ABD = m\angle ABC + m\angle CBD$. Substitute in what you know and solve the equation.

$$100^\circ = (4x + 2)^\circ + (3x - 7)^\circ$$

$$100^\circ = 7x - 5^\circ$$

$$105^\circ = 7x$$

$$15^\circ = x$$

So, $m\angle ABC = 4(15^\circ) + 2^\circ = 62^\circ$ and $m\angle CBD = 3(15^\circ) - 7^\circ = 38^\circ$.

Practice

1. What is $m\angle LMN$ if $m\angle LMO = 85^\circ$ and $m\angle NMO = 53^\circ$?

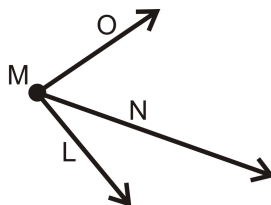

2. If $m\angle ABD = 100^\circ$, find x .

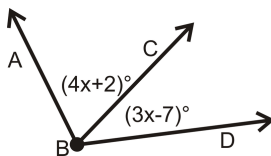

For questions 3-6, determine if the statement is true or false.

3. For an angle $\angle ABC$, C is the vertex.
4. For an angle $\angle ABC$, \overline{AB} and \overline{BC} are the sides.
5. The m in front of $m\angle ABC$ means measure.
6. The Angle Addition Postulate says that an angle is equal to the sum of the smaller angles around it.

For 7-12, draw the angle with the given degree, using a protractor and a ruler.

7. 55°
8. 92°
9. 178°
10. 5°
11. 120°
12. 73°

For 13-16, use a protractor to determine the measure of each angle.

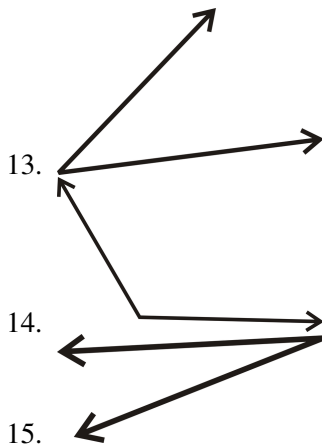

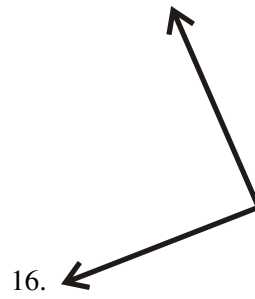

Solve for x .

17. $m\angle ADC = 56^\circ$

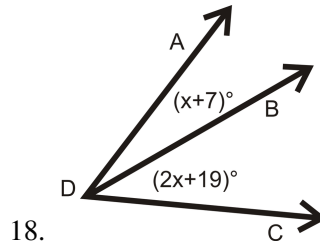

19. $m\angle ADC = 130^\circ$

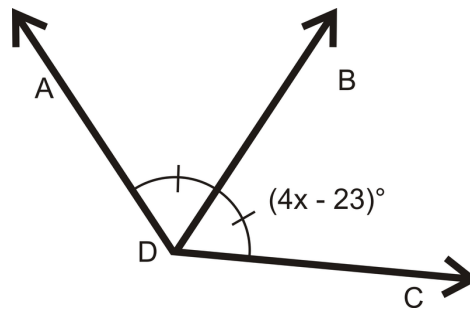

20. $m\angle ADC = (16x - 55)^\circ$

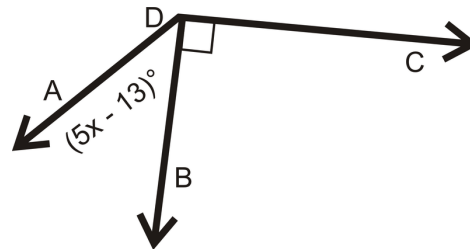

21. $m\angle ADC = (9x - 80)^\circ$

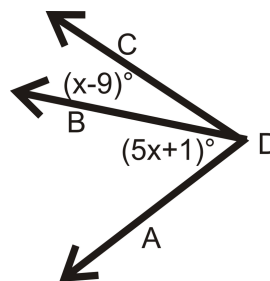

1.6 Angle Classification

Here you'll learn how to classify angles based on their measure.

What if you wanted to group different angles into different categories? After completing this Concept, you'll be able to classify angles geometrically.

Watch This



MEDIA

Click image to the left for more content.

[CK-12 Foundation: Chapter1AngleClassificationA](#)

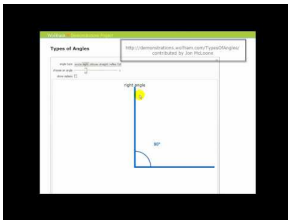

MEDIA

Click image to the left for more content.

[James Sousa:Animation of Types of Angles](#)

Guidance

By looking at the protractor we measure angles from 0° to 180° . Angles can be classified, or grouped, into four different categories.

Straight Angle: When an angle measures 180° . The angle measure of a straight line. The rays that form this angle are called opposite rays.



Right Angle: When an angle measures 90° .

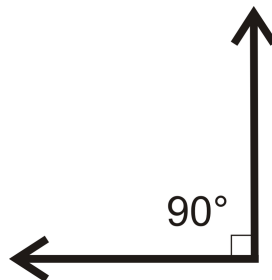

Notice the half-square, marking the angle. This marking is always used to mark right, or 90° , angles.

Acute Angles: Angles that measure between 0° and 90° .

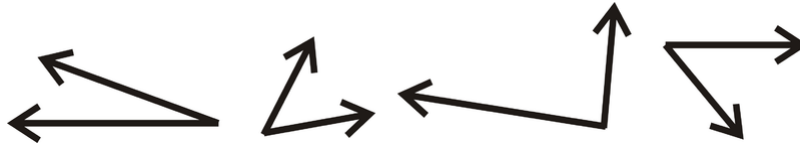

Obtuse Angles: Angles that measure between 90° and 180° .

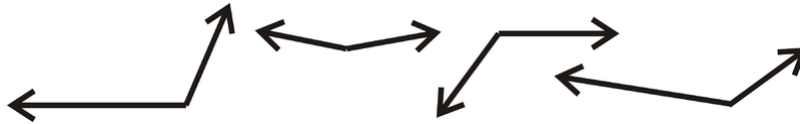

It is important to note that 90° is NOT an acute angle and 180° is NOT an obtuse angle.

Any two lines or line segments can intersect to form four angles. If the two lines intersect to form right angles, we say the lines are **perpendicular**.

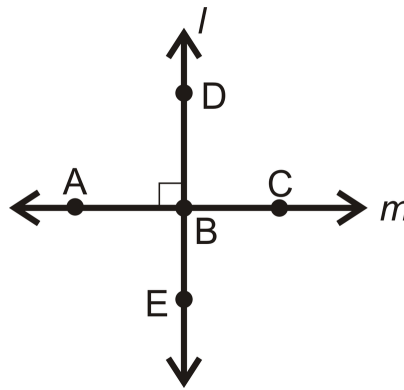

The symbol for perpendicular is \perp , so these two lines would be labeled $l \perp m$ or $\overleftrightarrow{AC} \perp \overleftrightarrow{DE}$.

There are several other ways to label these two intersecting lines. This picture shows **two perpendicular lines**, **four right angles**, **four 90° angles**, and even **two straight angles**, $\angle ABC$ and $\angle DBE$.

Example A

Name the angle and determine what type of angle it is.

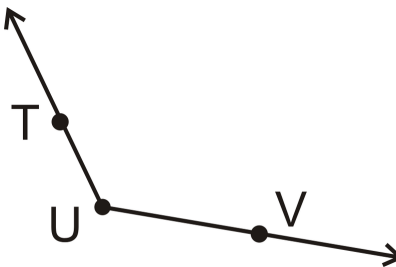

The vertex is U . So, the angle can be $\angle TUV$ or $\angle VUT$. To determine what type of angle it is, compare it to a right angle. Because it opens wider than a right angle and less than a straight angle it is **obtuse**.

Example B

What type of angle is 165° ?

165° is greater than 90° , but less than 180° , so it is **obtuse**.

Example C

What type of angle is 84° ?

84° is less than 90° , so it is **acute**.

Watch this video for help with the Examples above.



MEDIA

Click image to the left for more content.

[CK-12 Foundation: Chapter1AngleClassificationB](#)

Vocabulary

A **straight angle** is when an angle measures 180° . A **right angle** is when an angle measures 90° . **Acute angles** are angles that measure between 0° and 90° . **Obtuse angles** are angles that measure between 90° and 180° . If two lines intersect to form right angles, the lines are **perpendicular**.

Guided Practice

Name each type of angle:

1. 90°
2. 67°
3. 180°

Answers:

1. Right
2. Acute
3. Straight

Practice

For exercises 1-5, determine if the statement is true or false.

1. Two angles always add up to be greater than 90° .
2. 180° is an obtuse angle.
3. 180° is a straight angle.
4. Two perpendicular lines intersect to form four right angles.
5. A right angle and an acute angle make an obtuse angle.

For exercises 6-11, state what type of angle it is.

6. 55°
7. 92°
8. 178°
9. 5°
10. 120°
11. 73°
12. Interpret the picture to the right. Write down all equal angles, segments and if any lines are perpendicular.

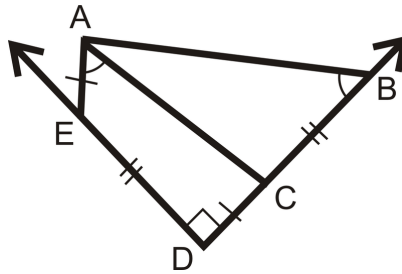

13. Draw a picture with the following requirements.

$$AB = BC = BD$$

$$m\angle ABC = m\angle CBD$$

$$m\angle ABD = 90^\circ$$

A, B, C and D are coplanar

In 14 and 15, plot and sketch $\angle ABC$. Classify the angle. Write the coordinates of a point that lies in the interior of the angle.

14. $A(5, -3), B(-3, -1), C(2, 2)$

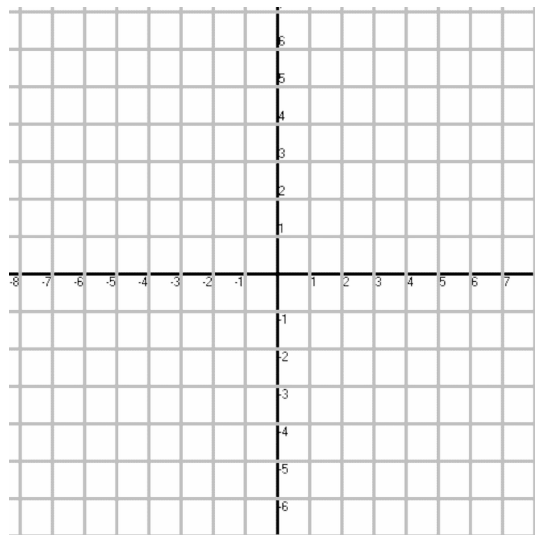

15. $A(-3, 0), B(1, 3), C(5, 0)$

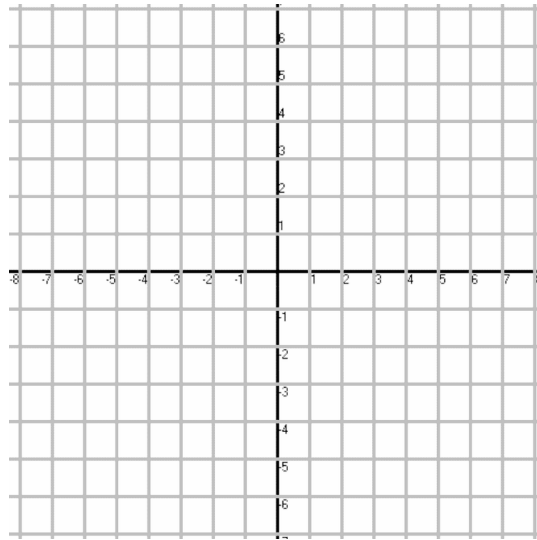

1.7 Complementary Angles

Here you'll learn what complementary angles are and how they can help you to solve problems.

What if you knew that two angles together made a right angle? After completing this Concept, you'll be able to use what you know about complementary angles to solve problems about these angles.

Watch This



MEDIA

Click image to the left for more content.

[CK-12 Foundation: Chapter 1 Complementary Angles A](#)

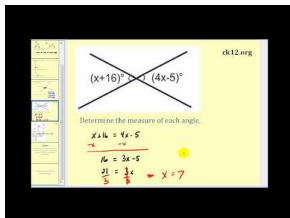

MEDIA

Click image to the left for more content.

[James Sousa: Complementary Angles](#)

Guidance

Two angles are **complementary** when they add up to 90° . Complementary angles do not have to be congruent to each other, nor do they have to be next to each other.

Example A

The two angles below are complementary. $m\angle GHI = x$. What is x ?

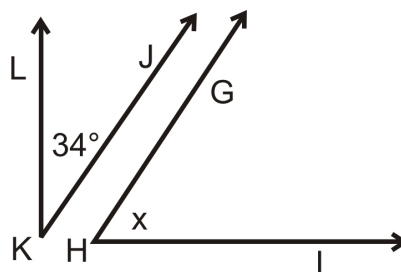

Because the two angles are complementary, they add up to 90° . Make an equation.

$$\begin{aligned}x + 34^\circ &= 90^\circ \\x &= 56^\circ\end{aligned}$$

Example B

The two angles below are complementary. Find the measure of each angle.

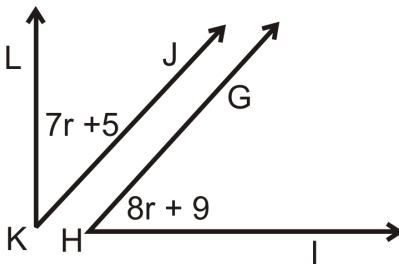

Again, the two angles add up to 90° . Make an equation.

$$\begin{aligned}8r + 9^\circ + 7r + 5^\circ &= 90^\circ \\15r + 14^\circ &= 90^\circ \\15r &= 76^\circ \\r &= 5.067^\circ\end{aligned}$$

However, this is not what the question asks for. You need to plug r back into each expression to find each angle.

$$\begin{aligned}m\angle GHI &= 8(5^\circ) + 9^\circ = 49^\circ \\m\angle JKL &= 7(5^\circ) + 6^\circ = 41^\circ\end{aligned}$$

Example C

Name one pair of complementary angles in the diagram below.

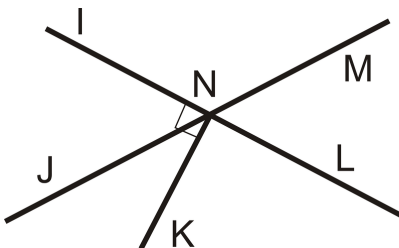

One example is $\angle INJ$ and $\angle JNK$.

Watch this video for help with the Examples above.



MEDIA

 Click image to the left for more content.

CK-12 Foundation: Chapter 1 Complementary Angles B

Vocabulary

Two angles are *complementary* when they add up to 90° .

Guided Practice

Find the measure of an angle that is complementary to $\angle ABC$ if $m\angle ABC$ is

1. 45°
2. 82°
3. 19°
4. z°

Answers:

1. 45°
2. 8°
3. 71°
4. $90 - z^\circ$

Practice

Find the measure of an angle that is complementary to $\angle ABC$ if $m\angle ABC$ is:

1. 3°
2. 82°
3. 51°
4. 30°
5. 22°
6. $(x + y)^\circ$
7. x°

Use the diagram below for exercises 8-9. Note that $\overline{NK} \perp \overleftrightarrow{IL}$.

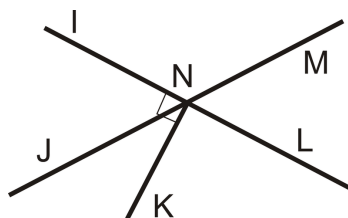

8. If $m\angle INJ = 60^\circ$, find $m\angle KNJ$.
9. If $m\angle INJ = 70^\circ$, find $m\angle KNJ$.

For 10-15, determine if the statement is true or false.

10. Complementary angles add up to 180° .
11. Complementary angles are always 45° .
12. Complementary angles are always next to each other.
13. Complementary angles add up to 90° .
14. Two angles that make a right angle are complementary.
15. The two non-right angles in a right triangle are complementary.

1.8 Supplementary Angles

Here you'll learn what supplementary angles are and how they can help you to solve problems.

What if you were given two supplementary angles? How would you determine their angle measures? After completing this Concept, you'll be able to use the definition of supplementary angles to solve problems like this one.

Watch This



MEDIA

Click image to the left for more content.

CK-12 Foundation: Chapter 1 Supplementary Angles A

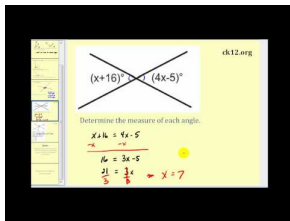

MEDIA

Click image to the left for more content.

James Sousa: Supplementary Angles

Guidance

Two angles are **supplementary** when they add up to 180° . Supplementary angles do not have to be congruent or touching.

Example A

The two angles below are supplementary. If $m\angle MNO = 78^\circ$ what is $m\angle PQR$?

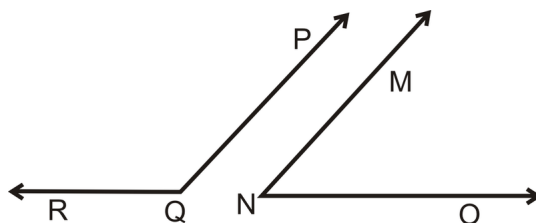

Set up an equation.

$$78^\circ + m\angle PQR = 180^\circ$$

$$m\angle PQR = 102^\circ$$

Example B

What are the measures of two congruent, supplementary angles?

Supplementary angles add up to 180° . Congruent angles have the same measure. Divide 180° by 2, to find the measure of each angle.

$$180^\circ \div 2 = 90^\circ$$

So, two congruent, supplementary angles are right angles, or 90° .

Example C

Name one pair of supplementary angles in the diagram below.

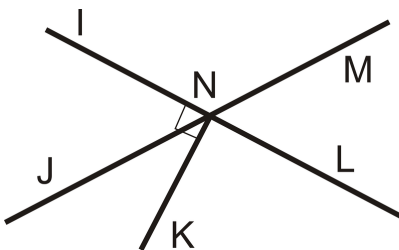

One example is $\angle INM$ and $\angle MNL$.

Watch this video for help with the Examples above.



MEDIA

Click image to the left for more content.

[CK-12 Foundation: Chapter1SupplementaryAnglesB](#)

Vocabulary

Two angles are *supplementary* when they add up to 180° .

Guided Practice

Find the measure of an angle that is supplementary to $\angle ABC$ if $m\angle ABC$ is

1. 45°
2. 118°
3. 32°
4. x°

Answers:

1. 135°
2. 62°
3. 148°
4. $180 - x^\circ$

Practice

Find the measure of an angle that is supplementary to $\angle ABC$ if $m\angle ABC$ is:

1. 112°
2. 15°
3. 97°
4. 81°
5. 57°
6. $(x - y)^\circ$
7. $(x + y)^\circ$

Use the diagram below for exercises 8-9. Note that $\overline{NK} \perp \overleftrightarrow{IL}$.

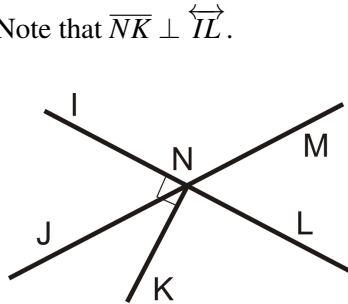

8. Name another pair of supplementary angles.
9. If $m\angle INJ = 63^\circ$, find $m\angle JNL$.

For exercises 10-13, determine if the statement is true or false.

10. Supplementary angles add up to 180° .
11. Two angles on a straight line are supplementary angles.
12. To be supplementary, two angles must be touching.
13. It's possible for two angles in a triangle to be supplementary.

For 14-15, find the value of x .

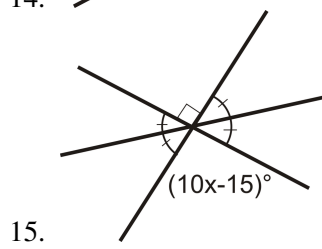
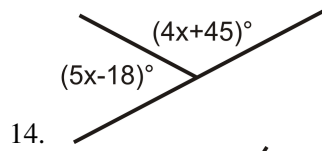

1.9 Linear Pairs

Here you'll learn what linear pairs are and how they can help you to solve problems.

What if you notice two angles in a picture that make a straight line? What information does this give you about the angles? After completing this Concept, you'll be able to apply the properties of linear pairs to help you solve problems.

Watch This



MEDIA

Click image to the left for more content.

CK-12 Foundation: Chapter 1 Linear Pairs A

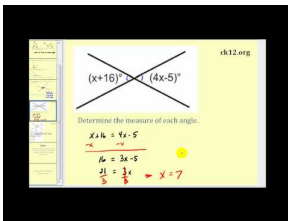

MEDIA

Click image to the left for more content.

James Sousa: Linear Pairs

Guidance

Adjacent angles are two angles that have the same vertex, share a side, and do not overlap. In the picture below, $\angle PSQ$ and $\angle QSR$ are adjacent.

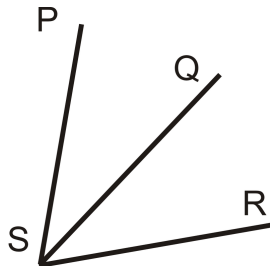

A **linear pair** is two angles that are adjacent and whose non-common sides form a straight line. If two angles are a linear pair, then they are supplementary.

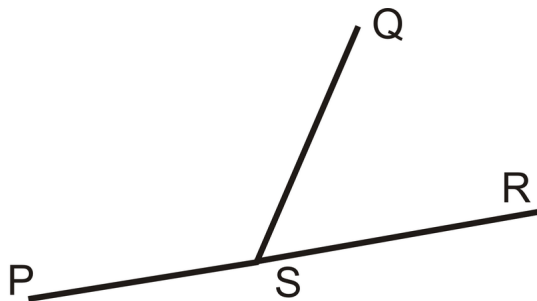

$\angle PSQ$ and $\angle QSR$ are a linear pair.

$$\begin{aligned} m\angle PSR &= 180^\circ \\ m\angle PSQ + m\angle QSR &= m\angle PSR \\ m\angle PSQ + m\angle QSR &= 180^\circ \end{aligned}$$

Example A

What is the value of each angle?

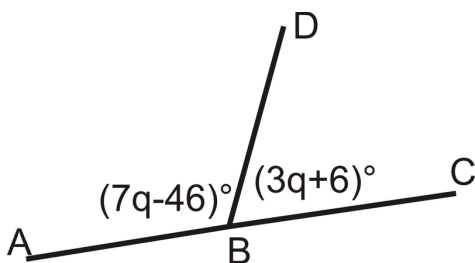

These two angles are a linear pair, so they are supplementary, or add up to 180° . Write an equation.

$$\begin{aligned} (7q - 46)^\circ + (3q + 6)^\circ &= 180^\circ \\ 10q - 40^\circ &= 180^\circ \\ 10q &= 220^\circ \\ q &= 22^\circ \end{aligned}$$

So, plug in q to get the measure of each angle.

$$m\angle ABD = 7(22^\circ) - 46^\circ = 108^\circ \quad m\angle DBC = 180^\circ - 108^\circ = 72^\circ$$

Example B

Are $\angle CDA$ and $\angle DAB$ a linear pair? Are they supplementary?

The two angles are not a linear pair because they do not have the same vertex. However, they are supplementary, $120^\circ + 60^\circ = 180^\circ$.

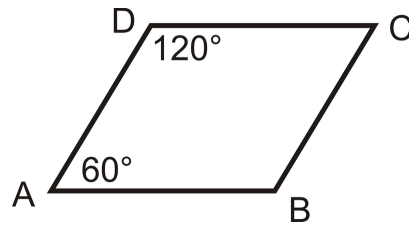
**Example C**

Name one linear pair in the diagram below.

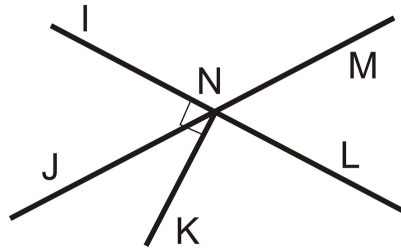

One example is $\angle INM$ and $\angle MNL$.

Watch this video for help with the Examples above.



MEDIA

Click image to the left for more content.

[CK-12 Foundation: Chapter1LinearPairsB](#)

Vocabulary

Adjacent angles are two angles that have the same vertex, share a side, and do not overlap. A **linear pair** is two angles that are adjacent and whose non-common sides form a straight line. If two angles are a linear pair, then they are **supplementary**.

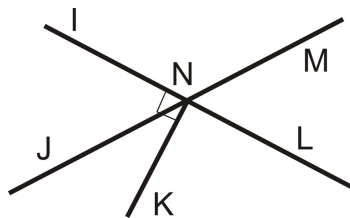
Guided Practice

1. What is $m\angle INL$?
2. What is $m\angle LNK$?

3. If $m\angle INJ = 63^\circ$, find $m\angle MNI$.

Answers:

1. 180°

2. 90°

3. $180^\circ - 63^\circ = 117^\circ$

Practice

For 1-5, determine if the statement is true or false.

1. Linear pairs are congruent.
2. Adjacent angles share a vertex.
3. Adjacent angles overlap.
4. Linear pairs are supplementary.
5. Supplementary angles form linear pairs.

Find the measure of an angle that forms a linear pair with $\angle MRS$ if $m\angle MRS$ is:

6. 54°
7. 32°
8. 104°
9. 71°
10. 149°
11. x°

For 12-16, find the value of x .

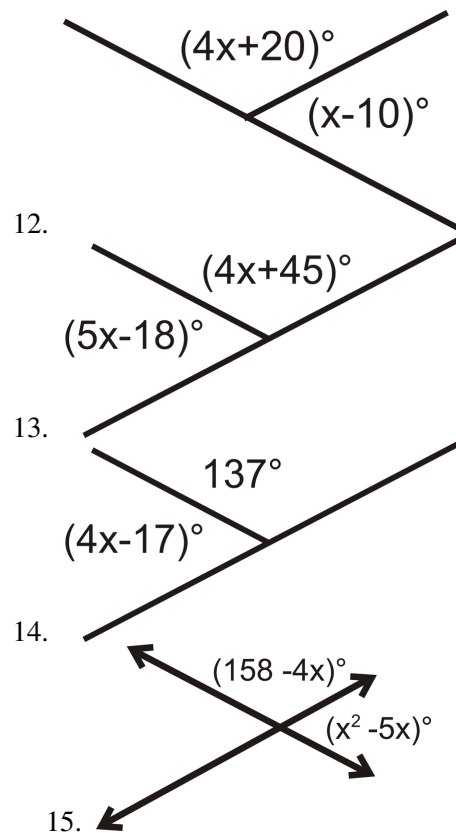

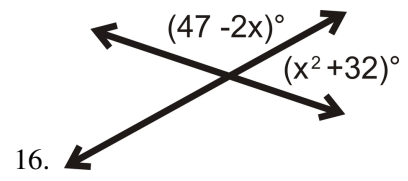

1.10 Vertical Angles

Here you'll learn about vertical angles and how they can help you to solve problems in geometry.

What if you want to know how opposite pairs of angles are related when two lines cross, forming four angles? After completing this Concept, you'll be able to apply the properties of these special angles to help you solve problems in geometry.

Watch This



MEDIA

Click image to the left for more content.

[CK-12 Foundation: Chapter1VerticalAnglesA](#)

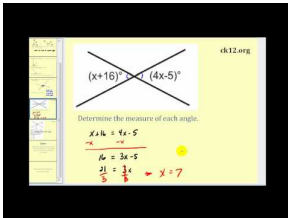

MEDIA

Click image to the left for more content.

[James Sousa:Vertical Angles](#)

Guidance

Vertical angles are two non-adjacent angles formed by intersecting lines. In the picture below, $\angle 1$ and $\angle 3$ are vertical angles and $\angle 2$ and $\angle 4$ are vertical angles.

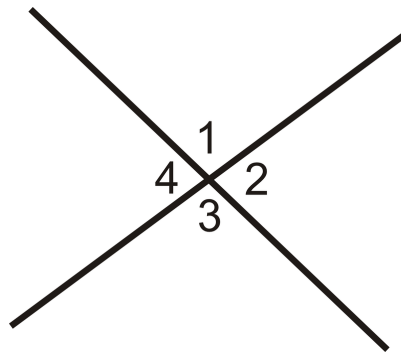

Notice that these angles are labeled with numbers. You can tell that these are labels because they do not have a degree symbol.

Investigation: Vertical Angle Relationships

1. Draw two intersecting lines on your paper. Label the four angles created $\angle 1$, $\angle 2$, $\angle 3$, and $\angle 4$. See the picture above.
2. Take your protractor and find $m\angle 1$.
3. What is the angle relationship between $\angle 1$ and $\angle 2$? Find $m\angle 2$.
4. What is the angle relationship between $\angle 1$ and $\angle 4$? Find $m\angle 4$.
5. What is the angle relationship between $\angle 2$ and $\angle 3$? Find $m\angle 3$.
6. Are any angles congruent? If so, write down the congruence statement.

From this investigation, hopefully you found out that $\angle 1 \cong \angle 3$ and $\angle 2 \cong \angle 4$. This is our first theorem. That means it must be proven true in order to use it.

Vertical Angles Theorem: If two angles are vertical angles, then they are congruent.

We can prove the Vertical Angles Theorem using the same process we used above. However, let's not use any specific values for the angles.

From the picture above:

$\angle 1$ and $\angle 2$ are a linear pair

$$m\angle 1 + m\angle 2 = 180^\circ$$

$\angle 2$ and $\angle 3$ are a linear pair

$$m\angle 2 + m\angle 3 = 180^\circ$$

$\angle 3$ and $\angle 4$ are a linear pair

$$m\angle 3 + m\angle 4 = 180^\circ$$

All of the equations = 180° , so set the first and second equation equal to each other and the second and third.

$$m\angle 1 + m\angle 2 = m\angle 2 + m\angle 3$$

AND

$$m\angle 2 + m\angle 3 = m\angle 3 + m\angle 4$$

Cancel out the like terms

$$m\angle 1 = m\angle 3, m\angle 2 = m\angle 4$$

Recall that anytime the measures of two angles are equal, the angles are also congruent.

Example A

Find $m\angle 1$ and $m\angle 2$.

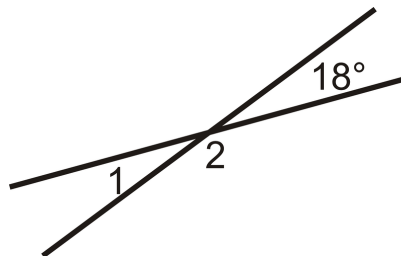

$\angle 1$ is vertical angles with 18° , so $m\angle 1 = 18^\circ$. $\angle 2$ is a linear pair with $\angle 1$ or 18° , so $18^\circ + m\angle 2 = 180^\circ$. $m\angle 2 = 180^\circ - 18^\circ = 162^\circ$.

Example B

Name one pair of vertical angles in the diagram below.

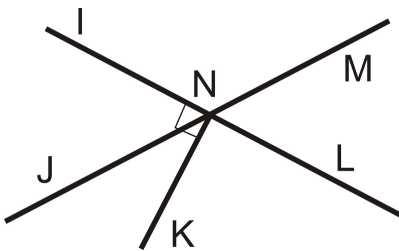

One example is $\angle INJ$ and $\angle MNL$.

Example C

If $\angle ABC$ and $\angle DBF$ are vertical angles and $m\angle ABC = (4x + 10)^\circ$ and $m\angle DBF = (5x + 2)^\circ$, what is the measure of each angle?

Vertical angles are congruent, so set the angles equal to each other and solve for x . Then go back to find the measure of each angle.

$$\begin{aligned} 4x + 10 &= 5x + 2 \\ x &= 8 \end{aligned}$$

So, $m\angle ABC = m\angle DBF = (4(8) + 10)^\circ = 42^\circ$

Watch this video for help with the Examples above.



MEDIA

Click image to the left for more content.

[CK-12 Foundation: Chapter1VerticalAnglesB](#)

Vocabulary

Vertical angles are two non-adjacent angles formed by intersecting lines. They are always congruent.

Guided Practice

Find the value of x or y .

1.

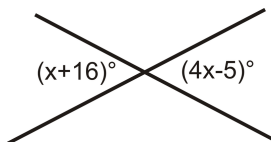

2.

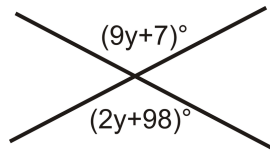

3.

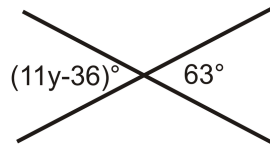
**Answers:**

1. Vertical angles are congruent, so set the angles equal to each other and solve for x .

$$\begin{aligned}x + 16 &= 4x - 5 \\3x &= 21 \\x &= 7^\circ\end{aligned}$$

2. Vertical angles are congruent, so set the angles equal to each other and solve for y .

$$\begin{aligned}9y + 7 &= 2y + 98 \\7y &= 91 \\y &= 13^\circ\end{aligned}$$

3. Vertical angles are congruent, so set the angles equal to each other and solve for y .

$$\begin{aligned}11y - 36 &= 63 \\11y &= 99 \\y &= 9^\circ\end{aligned}$$

Practice

Use the diagram below for exercises 1-2. Note that $\overline{NK} \perp \overleftrightarrow{IL}$.

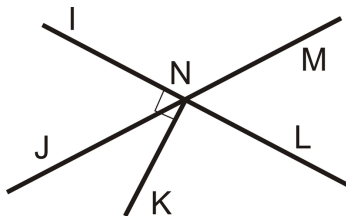

1. Name one pair of vertical angles.

2. If $m\angle INJ = 53^\circ$, find $m\angle MNL$.

For exercises 3-5, determine if the statement is true or false.

3. Vertical angles have the same vertex.
4. Vertical angles are supplementary.
5. Intersecting lines form two pairs of vertical angles.

Solve for the variables.

6. Find x .
7. Find y .

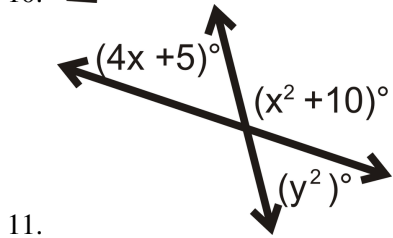
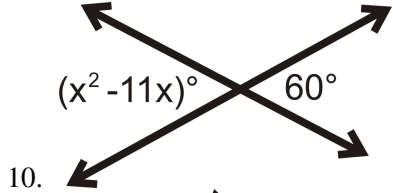
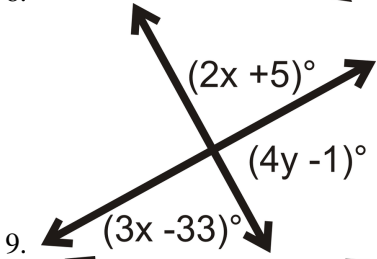
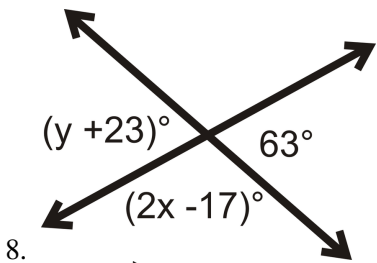
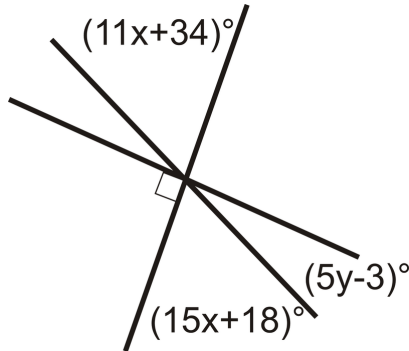

12. If $\angle ABC$ and $\angle DBF$ are vertical angles and $m\angle ABC = (4x + 1)^\circ$ and $m\angle DBF = (3x + 29)^\circ$, what is the measure of each angle?
13. If $\angle ABC$ and $\angle DBF$ are vertical angles and $m\angle ABC = (5x + 2)^\circ$ and $m\angle DBF = (6x - 32)^\circ$, what is the measure of each angle?

14. If $\angle ABC$ and $\angle DBF$ are vertical angles and $m\angle ABC = (x + 20)^\circ$ and $m\angle DBF = (4x + 2)^\circ$, what is the measure of each angle?
15. If $\angle ABC$ and $\angle DBF$ are vertical angles and $m\angle ABC = (2x + 10)^\circ$ and $m\angle DBF = (4x)^\circ$, what is the measure of each angle?

1.11 Triangle Classification

Here you'll learn how to classify a triangle based on its angles and sides.

What if you were given the angle measures or side lengths of several triangles and were asked to group them based on their properties? After completing this Concept, you'll be able to classify a triangle as right, obtuse, acute, equiangular, scalene, isosceles, and/or equilateral.

Watch This



MEDIA

Click image to the left for more content.

[CK-12 Foundation: Chapter1TriangleClassificationA](#)

Watch this video starting at around 2:30.

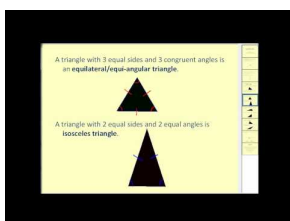

MEDIA

Click image to the left for more content.

[James Sousa:Types of Triangles](#)

Guidance

A **triangle** is any closed figure made by three line segments intersecting at their endpoints. Every triangle has three **vertices** (the points where the segments meet), three **sides** (the segments), and three **interior angles** (formed at each vertex). All of the following shapes are triangles.



You might have also learned that the sum of the interior angles in a triangle is 180° . Later we will prove this, but for now you can use this fact to find missing angles. Angles can be classified by their size: acute, obtuse or right. In any triangle, two of the angles will always be acute. The third angle can be acute, obtuse, or right. We classify each triangle by this angle.

Right Triangle: When a triangle has one right angle.

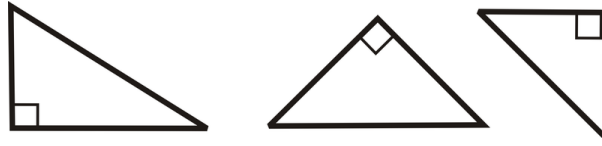

Obtuse Triangle: When a triangle has one obtuse angle.

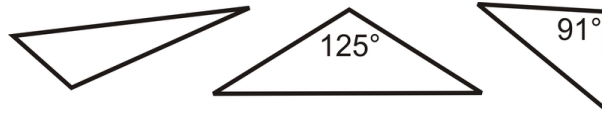

Acute Triangle: When all three angles in the triangle are acute.

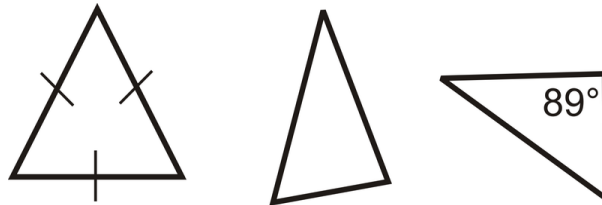

Equiangular Triangle: When all the angles in a triangle are congruent.

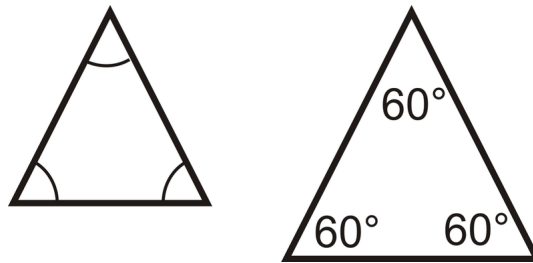

We can also classify triangles by its sides.

Scalene Triangle: When all sides of a triangle are all different lengths.

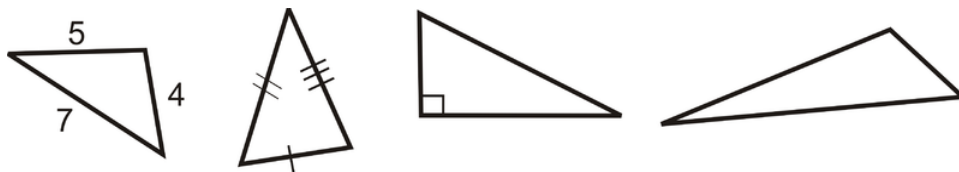

Isosceles Triangle: When *at least* two sides of a triangle are congruent.

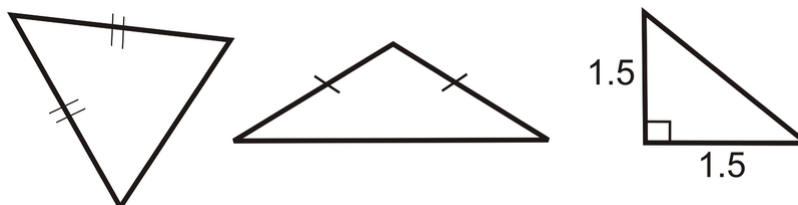

Equilateral Triangle: When all sides of a triangle are congruent.

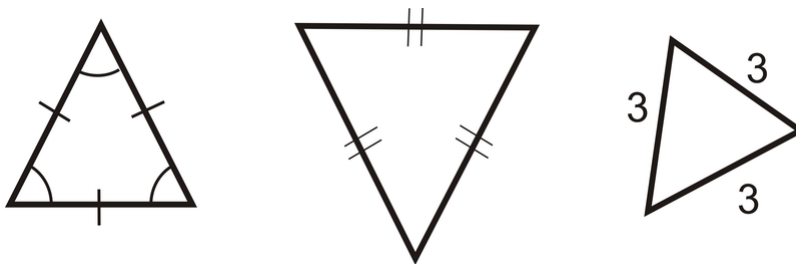

Note that by the above definitions, an equilateral triangle is also an isosceles triangle.

Example A

Which of the figures below are not triangles?

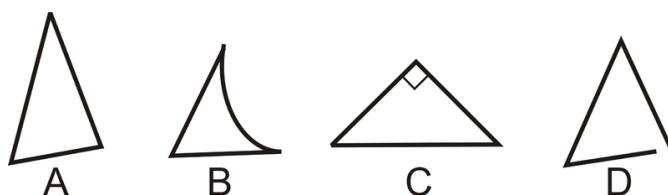

B is not a triangle because it has one curved side. *D* is not a closed shape, so it is not a triangle either.

Example B

Which term best describes $\triangle RST$ below?

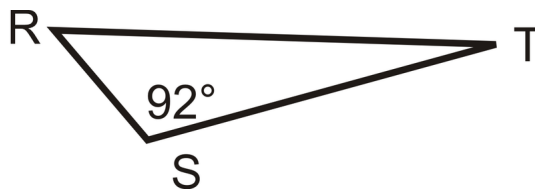

This triangle has one labeled obtuse angle of 92° . Triangles can only have one obtuse angle, so it is an obtuse triangle.

Example C

Classify the triangle by its sides and angles.

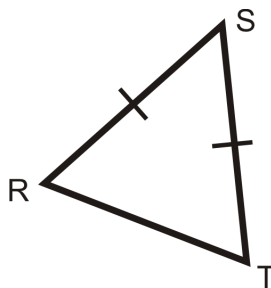

We are told there are two congruent sides, so it is an isosceles triangle. By its angles, they all look acute, so it is an acute triangle. Typically, we say this is an acute isosceles triangle.

Watch this video for help with the Examples above.



MEDIA

Click image to the left for more content.

[CK-12 Foundation: Chapter1TriangleClassificationB](#)

Vocabulary

A **triangle** is any closed figure made by three line segments intersecting at their endpoints. Every triangle has three **vertices** (the points where the segments meet), three **sides** (the segments), and three **interior angles** (formed at each vertex). A **right triangle** is a triangle with one right angle. An **obtuse triangle** is a triangle with one obtuse angle. An **acute triangle** is a triangle where all three angles are acute. An **equiangular triangle** is a triangle with all congruent angles. A **scalene triangle** is a triangle where all three sides are different lengths. An **isosceles triangle** is a triangle with at least two congruent sides. An **equilateral triangle** is a triangle with three congruent sides.

Guided Practice

1. How many triangles are in the diagram below?

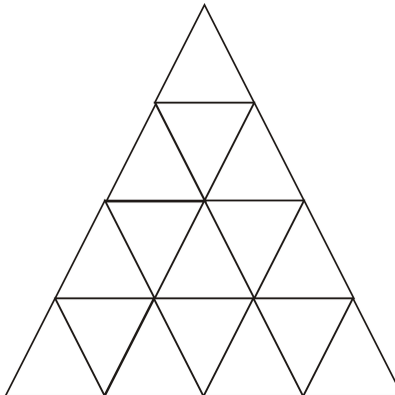

2. Classify the triangle by its sides and angles.

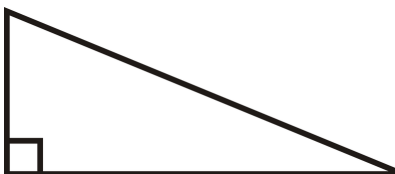

3. Classify the triangle by its sides and angles.

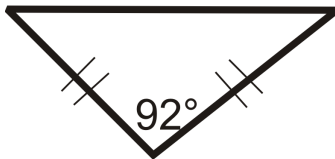

Answers:

1. Start by counting the smallest triangles, 16. Now count the triangles that are formed by four of the smaller triangles.

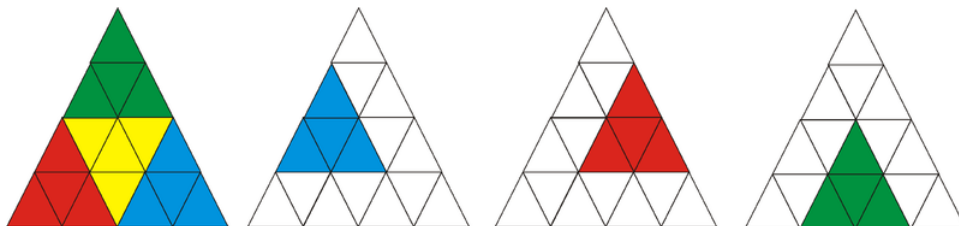

There are a total of seven triangles of this size, including the inverted one in the center of the diagram. Next, count the triangles that are formed by nine of the smaller triangles. There are three of this size. And finally, there is one triangle formed by the 16 smaller triangles. Adding these numbers together, we get $16 + 7 + 3 + 1 = 27$.

- 2. This triangle has a right angle and no sides are marked congruent. So, it is a right scalene triangle.
- 3. This triangle has an angle bigger than 90° and two sides that are marked congruent. So, it is an obtuse isosceles triangle.

Practice

For questions 1-6, classify each triangle by its sides and by its angles.

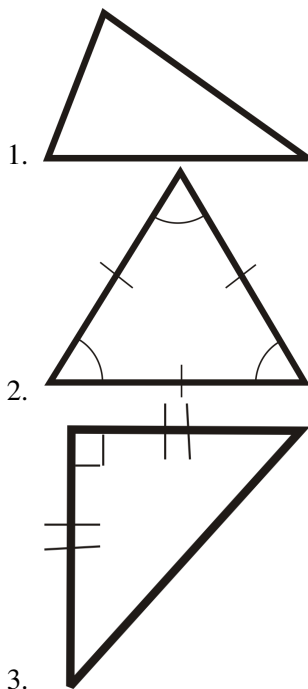

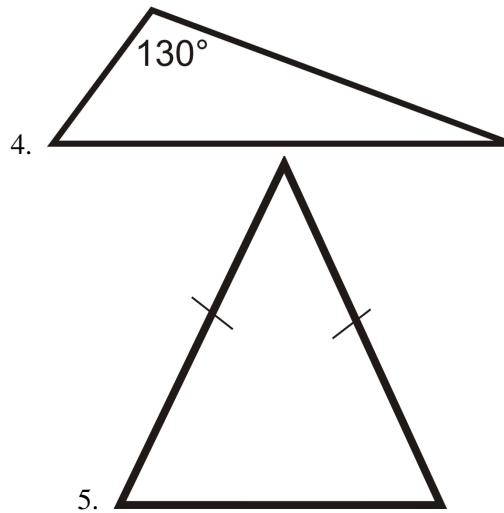

6. Can you draw a triangle with a right angle and an obtuse angle? Why or why not?
7. In an isosceles triangle, can the angles opposite the congruent sides be obtuse?
8. **Construction** Construct an equilateral triangle with sides of 3 cm. Start by drawing a horizontal segment of 3 cm and measure this side with your compass from both endpoints.
9. What must be true about the angles of your equilateral triangle from #8?

For 9-13, determine if the statement is ALWAYS true, SOMETIMES true, or NEVER true.

9. Obtuse triangles are isosceles.
10. A right triangle is acute.
11. An equilateral triangle is equiangular.
12. An isosceles triangle is equilateral.
13. Equiangular triangles are scalene.

In geometry it is important to know the difference between a sketch, a drawing and a construction. A sketch is usually drawn free-hand and marked with the appropriate congruence markings or labeled with measurement. It may or may not be drawn to scale. A drawing is made using a ruler, protractor or compass and should be made to scale. A construction is made using only a compass and ruler and should be made to scale.

For 14-15, construct the indicated figures.

14. Construct a right triangle with side lengths 3 cm, 4 cm and 5 cm.
15. Construct a 60° angle. (*Hint: Think about an equilateral triangle.*)

1.12 Polygon Classification

Here you'll learn how to classify a polygon based on its sides. You'll also learn how to decide whether a polygon is convex or concave.

What if you were told how many sides a polygon has? How would you describe the polygon based on that information? After completing this Concept, you'll be able to classify a polygon according to the number of sides it has.

Watch This



MEDIA

Click image to the left for more content.

[CK-12 Foundation: Chapter1PolygonClassificationA](#)

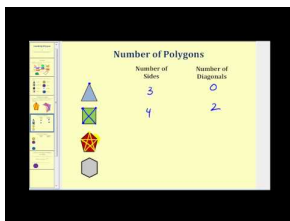

MEDIA

Click image to the left for more content.

[James Sousa:ClassifyingPolygons](#)

Guidance

A **polygon** is any closed planar figure that is made entirely of line segments that intersect at their endpoints. Polygons can have any number of sides and angles, but the sides can never be curved. The segments are called the **sides** of the polygons, and the points where the segments intersect are called **vertices**. The easiest way to identify a polygon is to look for a closed figure with no curved sides.

Polygons can be either **convex** or **concave**. Think of the term concave as referring to a cave, or “caving in”. A concave polygon has a section that “points inward” toward the middle of the shape. All stars are concave polygons.

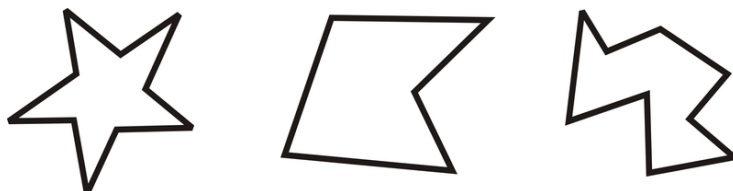

A convex polygon does not share this property.

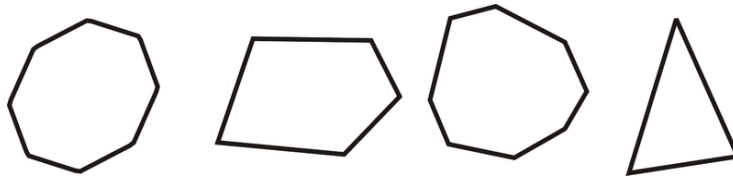

Diagonals are line segments that connect the vertices of a convex polygon that are not sides.

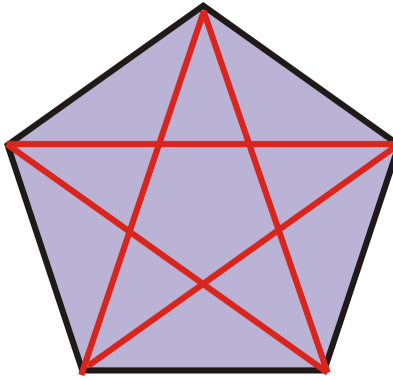

The red lines are all diagonals. This pentagon has 5 diagonals.

Whether a polygon is convex or concave, it can always be named by the number of sides. See the chart below.

TABLE 1.1:

| Polygon Name | Number of Sides | Number of Diagonals | Convex Example |
|---------------|-----------------|---------------------|---|
| Triangle | 3 | 0 |  |
| Quadrilateral | 4 | 2 |  |
| Pentagon | 5 | 5 |  |

TABLE 1.1: (continued)

| Polygon Name | Number of Sides | Number of Diagonals | Convex Example |
|-------------------------|-----------------|---------------------|---|
| Hexagon | 6 | 9 |  |
| Heptagon | 7 | 14 |  |
| Octagon | 8 | ? |  |
| Nonagon | 9 | ? |  |
| Decagon | 10 | ? |  |
| Undecagon hendecagon | or 11 | ? |  |

TABLE 1.1: (continued)

| Polygon Name | Number of Sides | Number of Diagonals | Convex Example |
|--------------|-----------------------|---------------------|---|
| Dodecagon | 12 | ? |  |
| n -gon | n (where $n > 12$) | ? |  |

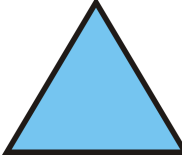
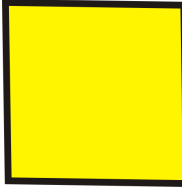
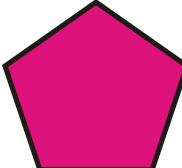
Example A

Which of the figures below is a polygon?

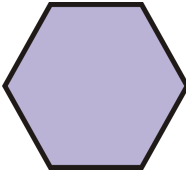
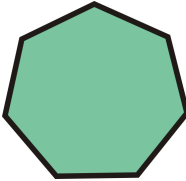
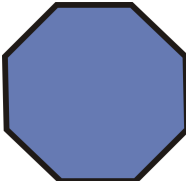
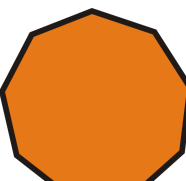
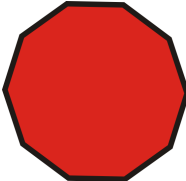
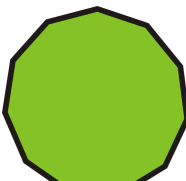
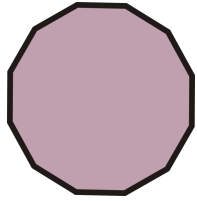
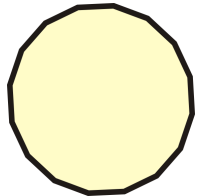
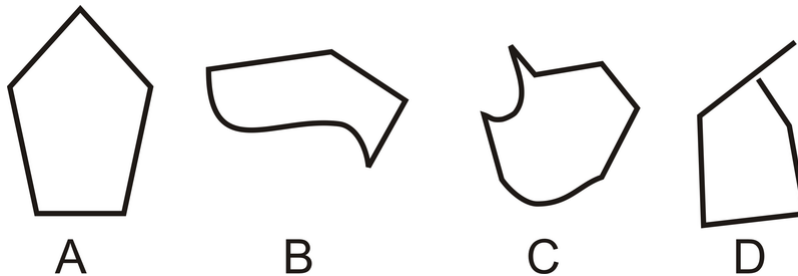

The easiest way to identify the polygon is to identify which shapes are not polygons. *B* and *C* each have at least one curved side, so they cannot be polygons. *D* has all straight sides, but one of the vertices is not at the endpoint of the adjacent side, so it is not a polygon either. *A* is the only polygon.

Example B

Determine if the shapes below are convex or concave.

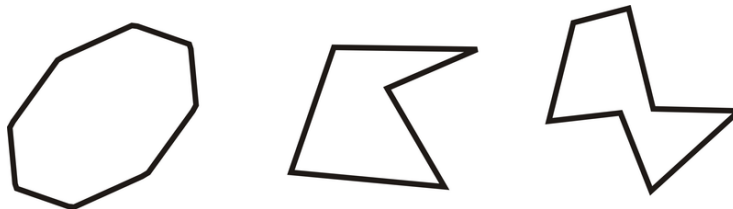

To see if a polygon is concave, look at the polygons and see if any angle “caves in” to the interior of the polygon. The first polygon does not do this, so it is convex. The other two do, so they are concave. You could add here that concave polygons have at least one diagonal outside the figure.

Example C

Which of the figures below is not a polygon?

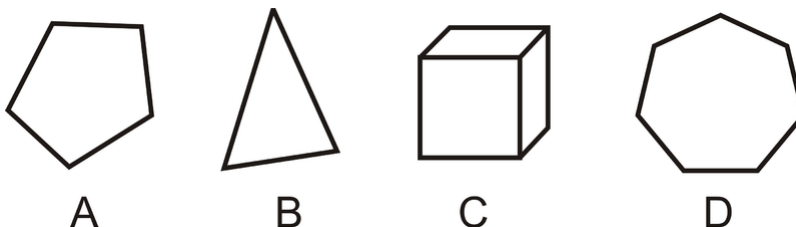

C is a three-dimensional shape, so it does not lie within one plane, so it is not a polygon.

Watch this video for help with the Examples above.



MEDIA

Click image to the left for more content.

[CK-12 Foundation: Chapter1PolygonClassificationB](#)

Vocabulary

A **polygon** is any closed planar figure that is made entirely of line segments that intersect at their endpoints. The segments are called the **sides** of the polygons, and the points where the segments intersect are called **vertices**. Polygons can be either **convex** or **concave**. A concave polygon has a section that “points inward” toward the middle of the shape. **Diagonals** are line segments that connect the vertices of a convex polygon that are not sides.

Guided Practice

Name the three polygons below by their number of sides and if it is convex or concave.

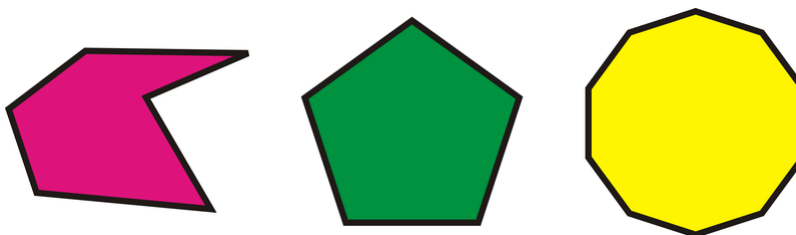
**Answers:**

- This shape has six sides and concave, so it is a concave hexagon.
- This shape has five sides and is convex, so it is a convex pentagon.
- This shape has ten sides and is convex, so it is a convex decagon.

Practice

In problems 1-6, name each polygon in as much detail as possible.

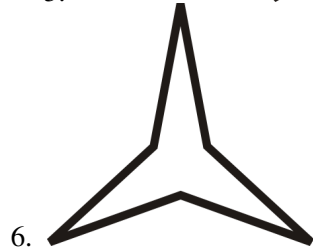
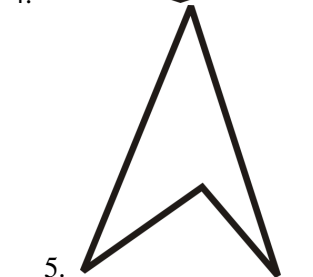
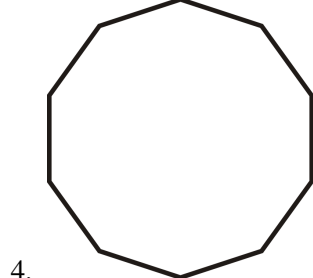
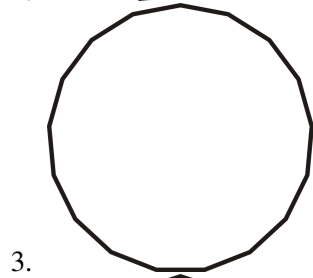
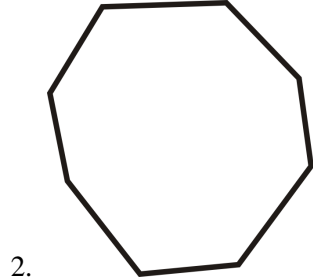

7. Explain why the following figures are NOT polygons:

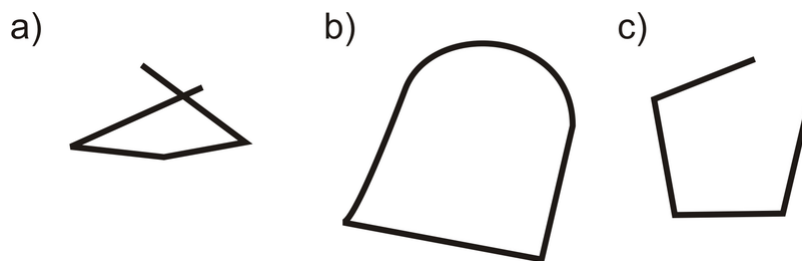

8. How many diagonals can you draw from **one vertex** of a pentagon? Draw a sketch of your answer.
9. How many diagonals can you draw from **one vertex** of an octagon? Draw a sketch of your answer.
10. How many diagonals can you draw from **one vertex** of a dodecagon?
11. Use your answers from 8-10 to figure out how many diagonals you can draw from **one vertex** of an n -gon?
12. Determine the number of total diagonals for an octagon, nonagon, decagon, undecagon, and dodecagon. Do you see a pattern? BONUS: Find the equation of the total number of diagonals for an n -gon.

For 13-17, determine if the statement is ALWAYS true, SOMETIMES true, or NEVER true.

13. A polygon must be enclosed.
14. A star is a concave polygon.
15. A quadrilateral is a square.
16. You can draw $(n - 1)$ triangles from one vertex of a polygon.
17. A decagon is a 5-point star.

In geometry it is important to know the difference between a sketch, a drawing and a construction. A sketch is usually drawn free-hand and marked with the appropriate congruence markings or labeled with measurement. It may or may not be drawn to scale. A drawing is made using a ruler, protractor or compass and should be made to scale. A construction is made using only a compass and ruler and should be made to scale.

For 18-21, draw, sketch or construct the indicated figures.

18. Sketch a convex heptagon with two sides congruent and three angles congruent.
19. Sketch a non-polygon figure.
20. Draw a concave pentagon with exactly two right angles and at least two congruent sides.
21. Draw an equilateral quadrilateral that is NOT a square.

Summary

This chapter begins with the basic components of Euclidean Geometry. From the introductory definition of points, lines, and planes it builds to a discussion of classifying figures such as angles, triangles, and polygons. Measurement of distances and angles are also covered. Different types of angle relationships are compared and explored, such as complementary angles, supplementary angles and linear pairs.

Symbol Toolbox for Chapter

\overleftrightarrow{AB} , \overrightarrow{AB} , \overline{AB} Line, ray, line segment

$\angle ABC$ Angle with vertex B

$m\overline{AB}$ or AB Distance between A and B

$m\angle ABC$ Measure of $\angle ABC$

\perp Perpendicular

$=$ Equal

\cong Congruent

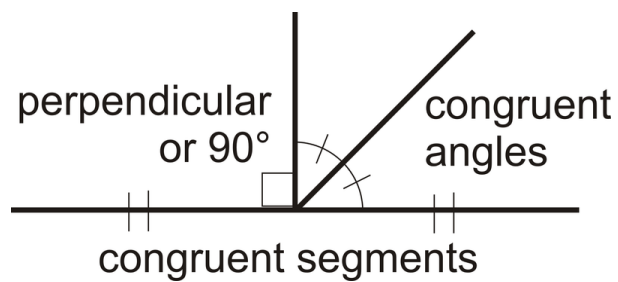

Chapter Keywords

- Geometry
- Point
- Line
- Plane
- Space
- Collinear
- Coplanar
- Endpoint:
- Line Segment
- Ray
- Intersection
- Postulates
- Theorem
- Distance
- Measure
- Ruler Postulate
- Segment Addition Postulate
- Angle
- Vertex
- Sides
- Protractor Postulate
- Straight Angle
- Right Angle
- Acute Angles
- Obtuse Angles
- Perpendicular
- Construction
- Compass
- Angle Addition Postulate
- Congruent
- Midpoint
- Midpoint Postulate
- Segment Bisector
- Perpendicular Bisector
- Perpendicular Bisector Postulate

- Angle Bisector
- Angle Bisector Postulate
- Complementary
- Supplementary
- Adjacent Angles
- Linear Pair
- Linear Pair Postulate
- Vertical Angles
- Vertical Angles Theorem
- Triangle
- Right Triangle
- Obtuse Triangle
- Acute Triangle
- Equiangular Triangle
- Scalene Triangle
- Isosceles Triangle
- Equilateral Triangle
- Polygon
- Diagonals

Chapter Review

Match the definition or description with the correct word.

TABLE 1.2: short caption

| Definition/Description | Answer |
|---|--------------------------------|
| 1. When three points lie on the same line. | A. Measure |
| 2. All vertical angles are _____. | B. Congruent |
| 3. Linear pairs add up to _____. | C. Angle Bisectors |
| 4. The m in front of $m\angle ABC$. | D. Ray |
| 5. What you use to measure an angle. | E. Collinear |
| 6. When two sides of a triangle are congruent. | F. Perpendicular. |
| 7. \perp | G. Line |
| 8. A line that passes through the midpoint of another line. | H. Protractor |
| 9. An angle that is greater than 90° . | I. Segment Addition Postulate. |
| 10. The intersection of two planes is a _____. | J. Obtuse |
| 11. $AB + BC = AC$ | K. Point |
| 12. An exact location in space. | L. 180° |
| 13. A sunbeam, for example | M. Isosceles |
| 14. Every angle has exactly one. | N. Pentagon |
| 15. A closed figure with 5 sides. | O. Hexagon |
| | P. Bisector |

Texas Instruments Resources

In the CK-12 Texas Instruments Geometry FlexBook, there are graphing calculator activities designed to supplement the objectives for some of the lessons in this chapter. See <http://www.ck12.org/flexr/chapter/9686>.

Reasoning and Proof

Chapter Outline

- 2.1 CONJECTURES AND COUNTEREXAMPLES
 - 2.2 IF-THEN STATEMENTS
 - 2.3 CONVERSE, INVERSE, AND CONTRAPOSITIVE
 - 2.4 INDUCTIVE REASONING FROM PATTERNS
 - 2.5 DEDUCTIVE REASONING
 - 2.6 TRUTH TABLES
 - 2.7 PROPERTIES OF EQUALITY AND CONGRUENCE
 - 2.8 TWO-COLUMN PROOFS
-

Introduction

This chapter explains how to reason and how to use reasoning to prove theorems about angle pairs and segments. This chapter also introduces the properties of congruence, which will also be used in proofs. Subsequent chapters will combine what you have learned in Chapters 1 and 2 and build upon them.

2.1 Conjectures and Counterexamples

Here you'll learn how to make educated guesses, or conjectures, based on patterns. You'll also learn how to disprove conjectures with counterexamples.

What if your older brother told you that all of his male friends at school play sports, so all guys must play sports. How could you prove him wrong? After completing this Concept, you will be able to make conjectures and disprove conjectures using counterexamples.

Watch This



MEDIA

Click image to the left for more content.

[CK-12 Foundation: Chapter2ConjecturesandCounterexamplesA](#)

Watch the final part of this video.

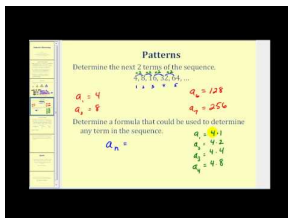

MEDIA

Click image to the left for more content.

[James Sousa:Counterexamples](#)

Guidance

A **conjecture** is an “educated guess” that is based on examples in a pattern. Numerous examples may make you believe a conjecture. However, no number of examples can actually *prove* a conjecture. It is always possible that the next example would show that the conjecture is false. A **counterexample** is an example that disproves a conjecture.

Example A

Here’s an algebraic equation and a table of values for n and with the result for t .

$$t = (n - 1)(n - 2)(n - 3)$$

TABLE 2.1:

| n | $(n-1)(n-2)(n-3)$ | t |
|-----|-------------------|-----|
| 1 | $(0)(-1)(-2)$ | 0 |
| 2 | $(1)(0)(-1)$ | 0 |
| 3 | $(2)(1)(0)$ | 0 |

After looking at the table, Pablo makes this conjecture:

The value of $(n-1)(n-2)(n-3)$ is 0 for any whole number value of n .

Is this a valid, or true, conjecture?

No, this is not a valid conjecture. If Pablo were to continue the table to $n = 4$, he would have seen that $(n-1)(n-2)(n-3) = (4-1)(4-2)(4-3) = (3)(2)(1) = 6$.

In this example $n = 4$ is a counterexample.

Example B

Arthur is making figures for a graphic art project. He drew polygons and some of their diagonals.

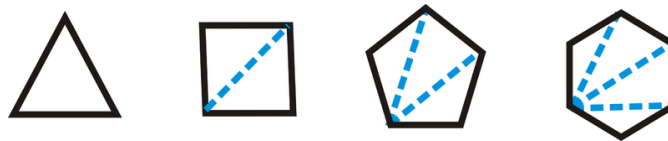

Based on these examples, Arthur made this conjecture:

If a convex polygon has n sides, then there are $n-2$ triangles drawn from any given vertex of the polygon.

Is Arthur's conjecture correct? Can you find a counterexample to the conjecture?

The conjecture appears to be correct. If Arthur draws other polygons, in every case he will be able to draw $n-2$ triangles if the polygon has n sides.

Notice that we have *not proved* Arthur's conjecture, but only found several examples that hold true. This type of conjecture would need to be proven by induction.

Example C

Give a counterexample to this statement: Every prime number is an odd number. The only counterexample is the number 2: an even number (not odd) that is prime.

Watch this video for help with the Examples above.



MEDIA

Click image to the left for more content.

Concept Problem Revisited

Your older brother made the conjecture that all guys must play sports. You could prove him wrong, or disprove his conjecture, by offering a counterexample.

Say your friend, John, is a guy and does not play sports. Just one counterexample is enough to disprove your brother's conjecture.

Vocabulary

A **conjecture** is an “educated guess” that is based on examples in a pattern. A **counterexample** is an example that disproves a conjecture.

Guided Practice

A car salesman sold 5 used cars to five different couples. He noticed that each couple was under 30 years old. The following day, he sold a new, luxury car to a couple in their 60's. The salesman determined that only younger couples buy used cars.

1. Is the salesman's conjecture logical? Why or why not?
2. Can you think of a counterexample?

Answers:

1. It is logical based on his experiences, but is not true.
2. A counterexample would be a couple that is 30 years old or older buying a used car.

Practice

Read the following examples of reasoning in the real world. Do you think the conjectures are true or can you give a counterexample?

1. For the last three days Tommy has gone for a walk in the woods near his house at the same time of day. Each time he has seen at least one deer. Tommy reasons that if he goes for a walk tomorrow at the same time, he will see deer again.
2. Maddie likes to bake. She especially likes to take recipes and make substitutions to try to make them healthier. She might substitute applesauce for butter or oat flour for white flour. She has noticed that she needs to add more baking powder or baking soda than the recipe indicates in these situations in order for the baked goods to rise appropriately.
3. One evening Juan saw a chipmunk in his backyard. He decided to leave a slice of bread with peanut butter on it for the creature to eat. The next morning the bread was gone. Juan concluded that chipmunks like to eat bread with peanut butter.
4. Sarah noticed that all her friends were in geometry class and reasoned that every 10th grade student is in geometry.
5. Describe an instance when you observed someone using invalid reasoning skills.

Give a counterexample for each of the following statements.

6. If n is an integer, then $n^2 > n$.
7. All numbers that end in 1 are prime numbers.
8. All positive fractions are between 0 and 1.

9. Any three points that are coplanar are also collinear.
10. All girls like ice cream.
11. All high school students are in choir.
12. For any angle there exists a complementary angle.
13. All teenagers can drive.
14. If n is an integer, then $n > 0$.
15. All equations have integer solutions.

2.2 If-Then Statements

Here you'll learn how to rewrite statements in if-then form and determine the hypothesis and conclusion.

Rube Goldberg was a cartoonist in the 1940s who drew crazy inventions to do very simple things. The invention below has a series of smaller tasks that leads to the machine wiping the man's face with a napkin.

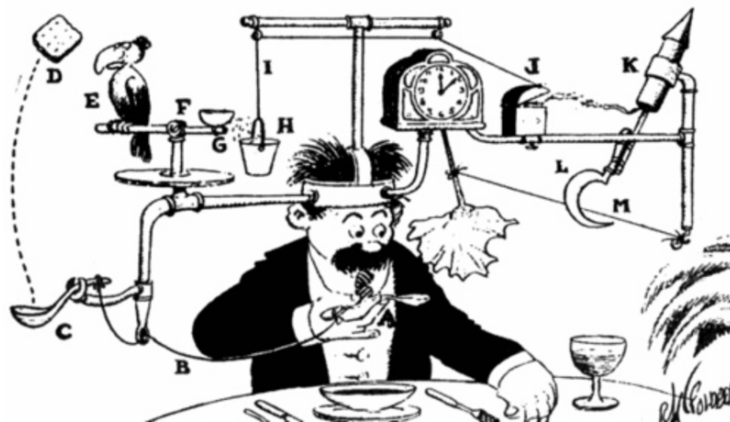

Write a series of if-then statements to that would caption this cartoon, from A to M. After completing this Concept, you'll be able to rewrite statements into if-then form.

Watch This



MEDIA

Click image to the left for more content.

[CK-12 Foundation: Chapter2IfThenStatementsA](#)

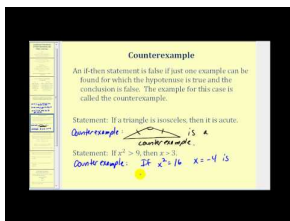

MEDIA

Click image to the left for more content.

[James Sousa:If-ThenStatements and Converses](#)

Guidance

A **conditional statement** (also called an **If-Then Statement**) is a statement with a hypothesis followed by a conclusion. Another way to define a conditional statement is to say, “If this happens, then that will happen.”

The **hypothesis** is the first, or “if,” part of a conditional statement. The **conclusion** is the second, or “then,” part of a conditional statement. The conclusion is the result of a hypothesis. Keep in mind that conditional statements might not always be written in the “if-then” form. Here are a few examples.

- **Statement 1:** If you work overtime, then you’ll be paid time-and-a-half.
- **Statement 2:** I’ll wash the car if the weather is nice.
- **Statement 3:** If 2 divides evenly into x , then x is an even number.
- **Statement 4:** I’ll be a millionaire when I win monopoly.
- **Statement 5:** All equiangular triangles are equilateral.

Statements 1 and 3 are written in the “if-then” form. The hypothesis of Statement 1 is “you work overtime.” The conclusion is “you’ll be paid time-and-a-half.” So, if Sarah works overtime, then what will happen? From Statement 1, we can conclude that she will be paid time-and-a-half. If 2 goes evenly into 16, what can you conclude? From Statement 3, we know that 16 must be an even number. Statement 2 has the hypothesis after the conclusion. Even though the word “then” is not there, the statement can be rewritten as: If the weather is nice, then I’ll wash the car. If the word “if” is in the middle of a conditional statement, the hypothesis is always after it. Statement 4 uses the word “when” instead of “if.” It should be treated like Statement 2, so it can be written as: If I win monopoly, then I will be a millionaire. In Statement 5 “if” and “then” are not there, but can be rewritten as: If a triangle is equiangular, then it is equilateral.

Example A

Rewrite the following statement in if-then form: *All students like geometry.*

Rewritten in if-then form, this statement would be *if you are a student, then you like geometry.*

Example B

Identify the hypothesis and the conclusion of the statement: Bob will go to the store if Anne tells him what to buy.

First, rewrite in if-then form. *If Anne tells Bob what to buy, then Bob will go to the store.* The hypothesis is *Anne tells Bob what to buy* because this has to come first. The conclusion, or result, is *Bob will go to the store.*

Example C

Identify the hypothesis and the conclusion of the statement: *I bring my umbrella when it is raining.*

Rewrite in if-then form, considering what causes what. In this situation, it is the rain that causes me to bring an umbrella (not bringing an umbrella that causes rain). *If it is raining, then I bring my umbrella.* The hypothesis is *it is raining* and the conclusion is *I bring my umbrella.*

Watch this video for help with the Examples above.



MEDIA

Click image to the left for more content.

CK-12 Foundation: Chapter2IfThenStatementsB

Concept Problem Revisited

The conditional statements are as follows:

$A \rightarrow B$: If the man raises his spoon, then it pulls a string.

$B \rightarrow C$: If the string is pulled, then it tugs back a spoon.

$C \rightarrow D$: If the spoon is tugged back, then it throws a cracker into the air.

$D \rightarrow E$: If the cracker is tossed into the air, the bird will eat it.

$E \rightarrow F$: If the bird eats the cracker, then it turns the pedestal.

$F \rightarrow G$: If the bird turns the pedestal, then the water tips over.

$G \rightarrow H$: If the water tips over, it goes into the bucket.

$H \rightarrow I$: If the water goes into the bucket, then it pulls down the string.

$I \rightarrow J$: If the bucket pulls down the string, then the string opens the box.

$J \rightarrow K$: If the box is opened, then a fire lights the rocket.

$K \rightarrow L$: If the rocket is lit, then the hook pulls a string.

$L \rightarrow M$: If the hook pulls the string, then the man's face is wiped with the napkin.

This is a very complicated contraption used to wipe a man's face. Purdue University liked these cartoons so much, that they started the Rube Goldberg Contest in 1949. This past year, the task was to pump hand sanitizer into someone's hand in no less than 20 steps.

**MEDIA**

Click image to the left for more content.

[Purdue University: Purdue team smashes Rube Goldbergworld record](#)

Vocabulary

A **conditional statement** (also called an **If-Then Statement**) is a statement with a hypothesis followed by a conclusion. The **hypothesis** is the first, or “if,” part of a conditional statement. The **conclusion** is the second, or “then,” part of a conditional statement.

Guided Practice

First rewrite in if-then form, then determine the hypothesis and conclusion.

1. Sally eats a snack if she is hungry.
2. The angles in a triangle add up to 180 degrees.
3. 2012 is a leap year.

Answers:

1. In if-then form, the statement is *If Sally is hungry, then she eats a snack*. The hypothesis is *Sally is hungry* and the conclusion is *she eats a snack*.
2. In if-then form, the statement is *If a shape is a triangle, then its angles add up to 180 degrees*. The hypothesis is *a shape is a triangle* and the conclusion is *its angles add up to 180 degrees*.
3. In if-then form, the statement is *If it is 2012, then it is a leap year*. The hypothesis is *it is 2012* and the conclusion is *it is a leap year*.

Practice

For questions 1-6, determine the hypothesis and the conclusion.

1. If 5 divides evenly into x , then x ends in 0 or 5.
2. If a triangle has three congruent sides, it is an equilateral triangle.
3. Three points are coplanar if they all lie in the same plane.
4. If $x = 3$, then $x^2 = 9$.
5. If you take yoga, then you are relaxed.
6. All baseball players wear hats.
7. I'll learn how to drive when I am 16 years old.
8. If you do your homework, then you can watch TV.
9. Alternate interior angles are congruent if lines are parallel.
10. All kids like ice cream.

Rewrite each statement in if-then form.

11. Susie eats pizza every Thursday.
12. Raychel always completes her homework.
13. Alex goes to school every weekday.
14. All students have a math class.
15. Squares have right angles.

2.3 Converse, Inverse, and Contrapositive

Here you'll learn how to find the converse, inverse and contrapositive of a conditional statement. You will also learn how to determine whether or not a statement is biconditional.

What if your sister told you "*if you do the dishes, then I will help you with your homework*"? What's a statement that is logically equivalent to what your sister said? After completing this Concept, you will know how to answer this question as you discover converses, inverses, and contrapositives, and how changing a conditional statement affects truth value.

Watch This



MEDIA

Click image to the left for more content.

[CK-12 Foundation: Chapter2ConverseInverseContrapositiveA](#)

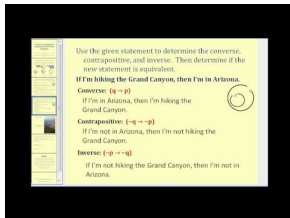

MEDIA

Click image to the left for more content.

[James Sousa:Converse, Contrapositive, and Inverse of anIf-ThenStatement](#)

Guidance

Consider the statement: *If the weather is nice, then I will wash the car.* This can be rewritten using letters to represent the hypothesis and conclusion:

If p , then q where p = the weather is nice and q = I will wash the car. Or, $p \rightarrow q$.

In addition to these positives, we can also write the negations, or “not”s of p and q . The symbolic version of not p , is $\sim p$.

$\sim p$ = the weather is not nice

$\sim q$ = I will not wash the car

Using these negations and switching the order of p and q , we can create three more conditional statements.

| | | |
|----------------|-----------------------------|---|
| Converse | $q \rightarrow p$ | If I wash the car, then the weather is nice. $\underbrace{\hspace{10em}}_q \quad \underbrace{\hspace{10em}}_p$ |
| Inverse | $\sim p \rightarrow \sim q$ | If the weather is not nice, then I won't wash the car. $\underbrace{\hspace{10em}}_{\sim p} \quad \underbrace{\hspace{10em}}_{\sim q}$ |
| Contrapositive | $\sim q \rightarrow \sim p$ | If I don't wash the car, then the weather is not nice. $\underbrace{\hspace{10em}}_{\sim q} \quad \underbrace{\hspace{10em}}_{\sim p}$ |

If we accept “If the weather is nice, then I’ll wash the car” as true, then the converse and inverse are not necessarily true. However, if we take the original statement to be true, then the contrapositive is also true. We say that the contrapositive is **logically equivalent** to the original if-then statement. It is sometimes the case that a statement and its converse will both be true. These types of statements are called **biconditional statements**. So, $p \rightarrow q$ is true and $q \rightarrow p$ is true. It is written $p \leftrightarrow q$, with a double arrow to indicate that it does not matter if p or q is first. It is said, “ p if and only if q ”. Replace the “if-then” with “if and only if” in the middle of the statement. “If and only if” can be abbreviated “iff.”

Example A

Use the statement: If $n > 2$, then $n^2 > 4$.

a) Find the converse, inverse, and contrapositive.

b) Determine if the statements from part a are true or false. If they are false, find a counterexample.

The original statement is true.

| | | |
|-------------------------|-------------------------------|---|
| <u>Converse</u> : | If $n^2 > 4$, then $n > 2$. | <i>False.</i> n could be -3 , making $n^2 = 9$. |
| <u>Inverse</u> : | If $n < 2$, then $n^2 < 4$. | <i>False.</i> Again, if $n = -3$, then $n^2 = 9$. |
| <u>Contrapositive</u> : | If $n^2 < 4$, then $n < 2$. | <i>True</i> , the only square number less than 4 is 1, which has square roots of 1 or -1, both less than 2. |

Example B

Use the statement: If I am at Disneyland, then I am in California.

a) Find the converse, inverse, and contrapositive.

b) Determine if the statements from part a are true or false. If they are false, find a counterexample.

The original statement is true.

| | |
|-------------------------|--|
| <u>Converse</u> : | If I am in California, then I am at Disneyland. <i>False.</i> I could be in San Francisco. |
| <u>Inverse</u> : | If I am not at Disneyland, then I am not in California. <i>False.</i> Again, I could be in San Francisco. |
| <u>Contrapositive</u> : | If I am not in California, then I am not at Disneyland. <i>True.</i> If I am not in the state, I couldn't be at Disneyland. |

Notice for the inverse and converse *we can use the same counterexample*. This is because the inverse and converse are also *logically equivalent*.

Example C

The following is a true statement:

$m\angle ABC > 90^\circ$ if and only if $\angle ABC$ is an obtuse angle.

Determine the two true statements within this biconditional.

Statement 1: If $m\angle ABC > 90^\circ$, then $\angle ABC$ is an obtuse angle

Statement 2: If $\angle ABC$ is an obtuse angle, then $m\angle ABC > 90^\circ$.

You should recognize this as the definition of an obtuse angle. All geometric definitions are biconditional statements.

Watch this video for help with the Examples above.



MEDIA

Click image to the left for more content.

[CK-12 Foundation: Chapter2ConverseInverseContrapositiveB](#)

Concept Problem Revisited

Your sister presented you with the if-then statement, "*If you do the dishes, then I will help you with your homework.*" If we take the original statement to be true, then the contrapositive is also true. The following contrapositive statement is *logically equivalent* to the original if-then statement:

"If I do not help you with your homework, then you will not do the dishes."

Vocabulary

A **conditional statement** (also called an **if-then statement**) is a statement with a hypothesis followed by a conclusion. The **hypothesis** is the first, or "if," part of a conditional statement. The **conclusion** is the second, or "then," part of a conditional statement. The conclusion is the result of a hypothesis. The **converse** of a conditional statement is when the hypothesis and conclusion are switched. The **inverse** of a conditional statement is when both the hypothesis and conclusions are negated. The **contrapositive** of a conditional statement is when the hypothesis and conclusions have been both switched and negated. When the original statement and converse are both true then the statement is a **biconditional statement**.

Guided Practice

- Use the statement: Any two points are collinear.
 - Find the converse, inverse, and contrapositive.
 - Determine if the statements from part a are true or false. If they are false, find a counterexample.
- $p : x < 10$ $q : 2x < 50$

- Is $p \rightarrow q$ true? If not, find a counterexample.
- Is $q \rightarrow p$ true? If not, find a counterexample.
- Is $\sim p \rightarrow \sim q$ true? If not, find a counterexample.
- Is $\sim q \rightarrow \sim p$ true? If not, find a counterexample.

Answers:

- First, change the statement into an “if-then” statement: If two points are on the same line, then they are collinear.

| | |
|-------------------------|---|
| <u>Converse</u> : | If two points are collinear, then they are on the same line. <i>True</i> . |
| <u>Inverse</u> : | If two points are not on the same line, then they are not collinear. <i>True</i> . |
| <u>Contrapositive</u> : | If two points are not collinear, then they do not lie on the same line. <i>True</i> . |

2.

| | |
|-------------------------------|---|
| $p \rightarrow q$: | If $x < 10$, then $2x < 50$. <i>True</i> . |
| $q \rightarrow p$: | If $2x < 50$, then $x < 10$. <i>False</i> , $x = 15$ would be a counterexample. |
| $\sim p \rightarrow \sim q$: | If $x > 10$, then $2x > 50$. <i>False</i> , $x = 15$ would also work here. |
| $\sim q \rightarrow \sim p$: | If $2x > 50$, then $x > 10$. <i>True</i> . |

Practice

For questions 1-4, use the statement: If $AB = 5$ and $BC = 5$, then B is the midpoint of \overline{AC} .

- If this is the converse, what is the original statement? Is it true?
- If this is the original statement, what is the inverse? Is it true?
- Find a counterexample of the statement.
- Find the contrapositive of the original statement from #1.
- What is the inverse of the inverse of $p \rightarrow q$? HINT: Two wrongs make a right in math!
- What is the one-word name for the converse of the inverse of an if-then statement?
- What is the one-word name for the inverse of the converse of an if-then statement?
- What is the contrapositive of the contrapositive of an if-then statement?

For questions 9-12, determine the two true conditional statements from the given biconditional statements.

- A U.S. citizen can vote if and only if he or she is 18 or more years old.
- A whole number is prime if and only if it has exactly two distinct factors.
- Points are collinear if and only if there is a line that contains the points.
- $2x = 18$ if and only if $x = 9$.
- $p : x = 4$ $q : x^2 = 16$
 - Is $p \rightarrow q$ true? If not, find a counterexample.
 - Is $q \rightarrow p$ true? If not, find a counterexample.
 - Is $\sim p \rightarrow \sim q$ true? If not, find a counterexample.
 - Is $\sim q \rightarrow \sim p$ true? If not, find a counterexample.
- $p : x = -2$ $q : -x + 3 = 5$
 - Is $p \rightarrow q$ true? If not, find a counterexample.

- b. Is $q \rightarrow p$ true? If not, find a counterexample.
 - c. Is $\sim p \rightarrow \sim q$ true? If not, find a counterexample.
 - d. Is $\sim q \rightarrow \sim p$ true? If not, find a counterexample.
15. p : the measure of $\angle ABC = 90^\circ$ q : $\angle ABC$ is a right angle
- a. Is $p \rightarrow q$ true? If not, find a counterexample.
 - b. Is $q \rightarrow p$ true? If not, find a counterexample.
 - c. Is $\sim p \rightarrow \sim q$ true? If not, find a counterexample.
 - d. Is $\sim q \rightarrow \sim p$ true? If not, find a counterexample.
16. p : the measure of $\angle ABC = 45^\circ$ q : $\angle ABC$ is an acute angle
- a. Is $p \rightarrow q$ true? If not, find a counterexample.
 - b. Is $q \rightarrow p$ true? If not, find a counterexample.
 - c. Is $\sim p \rightarrow \sim q$ true? If not, find a counterexample.
 - d. Is $\sim q \rightarrow \sim p$ true? If not, find a counterexample.
17. Write a conditional statement. Write the converse, inverse and contrapositive of your statement. Are they true or false? If they are false, write a counterexample.
18. Write a true biconditional statement. Separate it into the two true conditional statements.

2.4 Inductive Reasoning from Patterns

Here you'll learn how to inductively draw conclusions from patterns in order to make predictions and solve problems.

The Locker Problem: What if a new high school has just been completed? There are 1000 lockers in the school and they have been numbered from 1 through 1000. During recess, the students decide to try an experiment. When recess is over each student walks into the school one at a time. The first student will open all of the locker doors. The second student will close all of the locker doors with even numbers. The third student will change all of the locker doors that are multiples of 3 (*change means closing lockers that are open, and opening lockers that are closed*). The fourth student will change the position of all locker doors numbered with multiples of four and so on. Imagine that this continues until the 1000 students have followed the pattern with the 1000 lockers. At the end, which lockers will be open and which will be closed? After completing this Concept, you will be able to use inductive reasoning solve this problem.

Watch This



MEDIA

Click image to the left for more content.

CK-12 Foundation: Chapter2InductiveReasoningA

Watch the first two parts of this video.

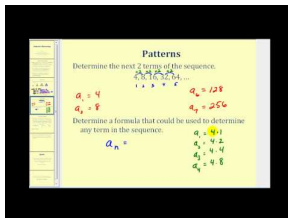

MEDIA

Click image to the left for more content.

James Sousa:Inductive Reasoning

Guidance

Inductive reasoning is making conclusions based upon observations and patterns. Visual patterns and number patterns provide good examples of inductive reasoning. Let's look at some patterns to get a feel for what inductive reasoning is.

Example A

A dot pattern is shown below. How many dots would there be in the bottom row of the 4th figure? What would the *total number* of dots be in the 6th figure?

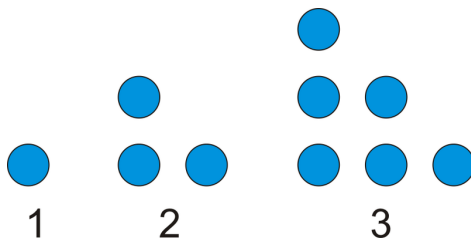

There will be 4 dots in the bottom row of the 4th figure. There is one more dot in the bottom row of each figure than in the previous figure.

There would be a total of 21 dots in the 6th figure, $6 + 5 + 4 + 3 + 2 + 1$.

Example B

How many *triangles* would be in the 10th figure?

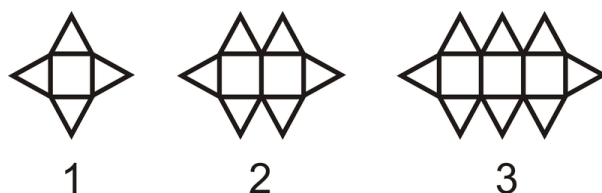

There are 10 squares, with a triangle above and below each square. There is also a triangle on each end of the figure. That makes $10 + 10 + 2 = 22$ triangles in all.

Example C

For two points, there is one line segment between them. For three non-collinear points, there are three line segments with those points as endpoints. For four points, no three points being collinear, how many line segments are between them? If you add a fifth point, how many line segments are between the five points?

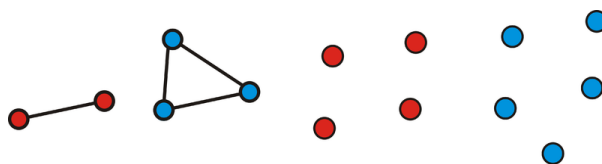

Draw a picture of each and count the segments.

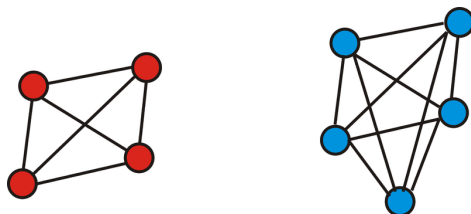

For 4 points there are 6 line segments and for 5 points there are 10 line segments.

Example D

Look at the pattern 2, 4, 6, 8, 10,...

- What is the 19th term in the pattern?
- Describe the pattern and try and find an equation that works for every term in the pattern.

For part a, each term is 2 more than the previous term.

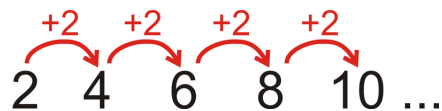

You could count out the pattern until the 19th term, but that could take a while. The easier way is to recognize the pattern. Notice that the 1st term is $2 \cdot 1$, the 2nd term is $2 \cdot 2$, the 3rd term is $2 \cdot 3$, and so on. So, the 19th term would be $2 \cdot 19$ or 38.

For part b, we can use this pattern to generate a formula. Typically with number patterns we use n to represent the term number. So, this pattern is 2 times the term number, or $2n$.

Example E

Look at the pattern: 3, 6, 12, 24, 48,...

- What is the next term in the pattern? The 10th term?
- Make a rule for the n^{th} term.

This pattern is different than the previous two examples. Here, each term is multiplied by 2 to get the next term.

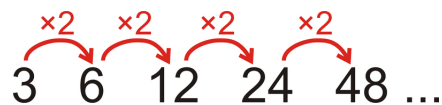

Therefore, the next term will be $48 \cdot 2$ or 96. To find the 10th term, we need to work on the pattern, let's break apart each term into the factors to see if we can find the rule.

TABLE 2.2:

| n | Pattern | Factors | Simplify |
|-----|---------|-------------------------------------|---------------|
| 1 | 3 | 3 | $3 \cdot 2^0$ |
| 2 | 6 | $3 \cdot 2$ | $3 \cdot 2^1$ |
| 3 | 12 | $3 \cdot 2 \cdot 2$ | $3 \cdot 2^2$ |
| 4 | 24 | $3 \cdot 2 \cdot 2 \cdot 2$ | $3 \cdot 2^3$ |
| 5 | 48 | $3 \cdot 2 \cdot 2 \cdot 2 \cdot 2$ | $3 \cdot 2^4$ |

Using this equation, the 10th term will be $3 \cdot 2^9$, or 1536. Notice that the exponent is one less than the term number. So, for the n^{th} term, the equation would be $3 \cdot 2^{n-1}$.

Watch this video for help with the Examples above.



MEDIA

 Click image to the left for more content.

[CK-12 Foundation: Chapter2InductiveReasoningB](#)

The Locker Problem Revisited

Start by looking at the pattern. Red numbers are OPEN lockers.

Student 1 changes every locker:

1, 2, 3, 4, 5, 6, 7, 8,... 1000

Student 2 changes every 2nd locker:

1, 2, 3, 4, 5, 6, 7, 8, 9, 10, 11, 12,... 1000

Student 3 changes every 3rd locker:

1, 2, 3, 4, 5, 6, 7, 8, 9, 10, 11, 12,... 1000

Student 4 changes every 4th locker:

1, 2, 3, 4, 5, 6, 7, 8, 9, 10, 11, 12,... 1000

If you continue on in this way, the only lockers that will be left open are the numbers with an odd number of factors, or the square numbers: 1, 4, 9, 16, 25, 36, 49, 64, 81, 100, 121, 144, 169, 196, 225, 256, 289, 324, 361, 400, 441, 484, 529, 576, 625, 676, 729, 784, 841, 900, and 961.

Vocabulary

Inductive reasoning is making conclusions based upon observations and patterns.

Guided Practice

1. If one of these figures contains 34 triangles, how many *squares* would be in that figure?

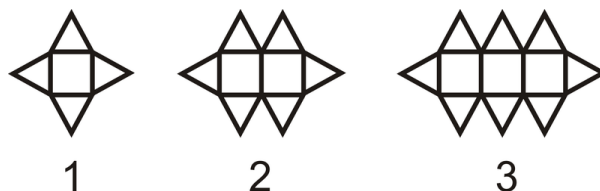

2. How can we find the number of triangles if we know the figure number?

3. Look at the pattern 1, 3, 5, 7, 9, 11,...

a) What is the 34th term in the pattern?

b) What is the n^{th} term?

4. Find the 8th term in the list of numbers as well as the rule.

$$2, \frac{3}{4}, \frac{4}{9}, \frac{5}{16}, \frac{6}{25} \dots$$

Answers:

1. First, the pattern has a triangle on each end. Subtracting 2, we have 32 triangles. Now, divide 32 by 2 because there is a row of triangles above and below each square. $32 \div 2 = 16$ squares.

2. Let n be the figure number. This is also the number of squares. $2n$ is the number of triangles above and below the squares. Add 2 for the triangles on the ends.

If the figure number is n , then there are $2n + 2$ triangles in all.

3. The pattern increases by 2 and is odd. From the previous example, we know that if a pattern increases by 2, you would multiply n by 2. However, this pattern is odd, so we need to add or subtract a number. Let's put what we know into a table:

TABLE 2.3:

| n | $2n$ | -1 | Pattern |
|-----|------|----|---------|
| 1 | 2 | -1 | 1 |
| 2 | 4 | -1 | 3 |
| 3 | 6 | -1 | 5 |
| 4 | 8 | -1 | 7 |
| 5 | 10 | -1 | 9 |
| 6 | 12 | -1 | 11 |

From this we can reason that the 34^{th} term would be $34 \cdot 2$ minus 1, which is 67. Therefore, the n^{th} term would be $2n - 1$.

4. First, change 2 into a fraction, or $\frac{2}{1}$. So, the pattern is now $\frac{2}{1}, \frac{3}{4}, \frac{4}{9}, \frac{5}{16}, \frac{6}{25} \dots$ Separate the top and the bottom of the fractions into two different patterns. The top is 2, 3, 4, 5, 6. It increases by 1 each time, so the 8^{th} term's numerator is 9. The denominators are the square numbers, so the 8^{th} term's denominator is 10^2 or 100. Therefore, the 8^{th} term is $\frac{9}{100}$. The rule for this pattern is $\frac{n+1}{n^2}$.

Practice

For questions 1 and 2, determine how many dots there would be in the 4^{th} and the 10^{th} pattern of each figure below.



3. Use the pattern below to answer the questions.



- Draw the next figure in the pattern.
- How does the number of points in each star relate to the figure number?
- Use part *b* to determine a formula for the n^{th} figure.

4. Use the pattern below to answer the questions. All the triangles are equilateral triangles.

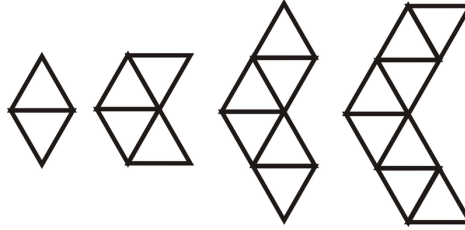

- Draw the next figure in the pattern. How many triangles does it have?
- Determine how many triangles are in the 24th figure.
- How many triangles are in the n^{th} figure?

For questions 5-12, determine: 1) the next two terms in the pattern, 2) the 35th term and 3) the formula for the n^{th} term.

- 5, 8, 11, 14, 17,...
- 6, 1, -4, -9, -14,...
- 2, 4, 8, 16, 32,...
- 67, 56, 45, 34, 23,...
- $\frac{1}{2}, \frac{2}{3}, \frac{3}{4}, \frac{4}{5}, \frac{5}{6}, \dots$
- $\frac{2}{3}, \frac{4}{7}, \frac{6}{11}, \frac{8}{15}, \frac{10}{19}, \dots$
- 1, 4, 9, 16, 25,...

For the following patterns find a) the next two terms, b) the 40th term and c) the n^{th} term rule. You will need to think about each of these in a different way. *Hint: Double all the values and look for a pattern in their factors. Once you come up with the rule remember to divide it by two to undo the doubling.*

- 2, 5, 9, 14,...
- 3, 6, 10, 15,...
- 3, 12, 30, 60,...
- Plot the values of the terms in the sequence 3, 8, 13, ... against the term numbers in the coordinate plane. In other words, plot the points (1, 3), (2, 8), and (3, 13). What do you notice? Could you use algebra to figure out the “rule” or equation which maps each term number (x) to the correct term value (y)? Try it.
- Which sequences in problems 5-11 follow a similar pattern to the one you discovered in #15? Can you use inductive reasoning to make a conclusion about which sequences follow the same type of rule?

2.5 Deductive Reasoning

Here you'll learn how to deductively draw conclusions from facts using the Law of Detachment, the Law of Contrapositive, and the Law of Syllogism.

What if, in a fictitious far-away land, a poor peasant were awaiting his fate from the king? He is standing in a stadium, filled with spectators pointing and wondering what is going to happen. Finally, the king directs everyone's attention to two doors, at the floor level with the peasant. Both doors have signs on them, which are below:

TABLE 2.4:

Door A

IN THIS ROOM THERE IS A LADY, AND IN THE OTHER ROOM THERE IS A TIGER.

Door B

IN ONE OF THESE ROOMS THERE IS A LADY, AND IN ONE OF THE OTHER ROOMS THERE IS A TIGER.

The king states, "Only one of these statements is true. If you pick correctly, you will find the lady. If not, the tiger will be waiting for you." Which door should the peasant pick? After completing this Concept, you'll be able to use deductive reasoning to solve this problem.

Watch This



MEDIA

Click image to the left for more content.

[CK-12 Foundation: Chapter2DeductiveReasoningA](#)

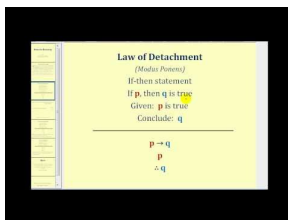

MEDIA

Click image to the left for more content.

[James Sousa:Introduction toDeductive Reasoning](#)

Guidance

Logic is the study of reasoning. **Deductive reasoning** draws conclusions from facts. Typically, conclusions are drawn from general statements about something more specific.

Law of Detachment

Here are two true statements:

- *Every odd number is the sum of an even and an odd number.*
- *5 is an odd number.*

What can you conclude? Based on only these two true statements, there is one conclusion: *5 is the sum of an even and an odd number.* (This is true, $5 = 3 + 2$ or $4 + 1$). Let's change this example into symbolic form.

p : A number is odd q : It is the sum of an even and odd number

So, the first statement is $p \rightarrow q$. The second statement, "5 is an odd number," is a specific example of p . "A number" is 5. The conclusion is q . Again it is a specific example, such as $4 + 1$ or $2 + 3$. The symbolic form is:

$$\begin{array}{l} p \rightarrow q \\ p \\ \therefore q \end{array} \quad \therefore \text{symbol for "therefore"}$$

All deductive arguments that follow this pattern have a special name, the Law of Detachment. The **Law of Detachment** says that if $p \rightarrow q$ is a true statement and given p , then you can conclude q . Another way to say the Law of Detachment is: "If $p \rightarrow q$ is true, and p is true, then q is true."

Law of Contrapositive

The following two statements are true:

- *If a student is in Geometry, then he or she has passed Algebra I.*
- *Daniel has not passed Algebra I.*

What can you conclude from these two statements? These statements are in the form:

$$\begin{array}{l} p \rightarrow q \\ \sim q \end{array}$$

$\sim q$ is the beginning of the contrapositive ($\sim q \rightarrow \sim p$), therefore the logical conclusion is $\sim p$: *Daniel is not in Geometry.* This example is called the Law of Contrapositive. The **Law of Contrapositive** says that if $p \rightarrow q$ is a true statement and given $\sim q$, then you can conclude $\sim p$. Recall that the logical equivalent to a conditional statement is its contrapositive. Therefore, the Law of Contrapositive is a logical argument.

Law of Syllogism

Determine the conclusion from the following true statements.

- *If Pete is late, Mark will be late.*

- If Mark is late, Karl will be late.

So, if Pete is late, what will happen? If Pete is late, this starts a domino effect of lateness. Mark will be late and Karl will be late too. So, if Pete is late, then *Karl will be late*, is the logical conclusion. Each “then” becomes the next “if” in a chain of statements. The chain can consist of any number of connected statements. This is called the Law of Syllogism. The **Law of Syllogism** says that if $p \rightarrow q$ and $q \rightarrow r$ are true, then $p \rightarrow r$ is the logical conclusion.

Typically, when there are more than two linked statements, we continue to use the next letter(s) in the alphabet to represent the next statement(s); $r \rightarrow s, s \rightarrow t$, and so on.

Example A

Suppose Bea makes the following statements, which are known to be true.

If Central High School wins today, they will go to the regional tournament.

Central High School won today.

What is the logical conclusion?

This is an example of deductive reasoning. There is one logical conclusion if these two statements are true: *Central High School will go to the regional tournament.*

Example B

Here are two true statements. *Be careful!*

If $\angle A$ and $\angle B$ are a linear pair, then $m\angle A + m\angle B = 180^\circ$.

$m\angle 1 = 90^\circ$ and $m\angle 2 = 90^\circ$.

What conclusion can you draw from these two statements?

Here there is NO conclusion. These statements are in the form:

$$p \rightarrow q$$

$$q$$

We **cannot** conclude that $\angle 1$ and $\angle 2$ are a linear pair. We are told that $m\angle 1 = 90^\circ$ and $m\angle 2 = 90^\circ$ and while $90^\circ + 90^\circ = 180^\circ$, this does not mean they are a linear pair. Here are two counterexamples.

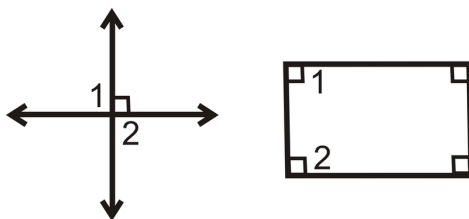

In both of these counterexamples, $\angle 1$ and $\angle 2$ are right angles. In the first, they are vertical angles and in the second, they are two angles in a rectangle.

This is called the *Converse Error* because the second statement is the conclusion of the first, like the converse of a statement.

Example C

Determine the conclusion from the true statements below.

Babies wear diapers.

My little brother does not wear diapers.

The second statement is the equivalent of $\sim q$. Therefore, the conclusion is $\sim p$, or: *My little brother is not a baby.*

Watch this video for help with the Examples above.



MEDIA

Click image to the left for more content.

[CK-12 Foundation: Chapter2DeductiveReasoningB](#)

Concept Problem Revisited

Analyze the two statements on the doors.

Door A: IN THIS ROOM THERE IS A LADY, AND IN THE OTHER ROOM THERE IS A TIGER.

Door B: IN ONE OF THESE ROOMS THERE IS A LADY, AND IN ONE OF THE OTHER ROOMS THERE IS A TIGER.

We know that one door is true, so the other one must be false. Let's assume that Door A is true. That means the lady is behind Door A and the tiger is behind Door B. However, if we read Door B carefully, it says "in one of these rooms," which means the lady could be behind either door, which is actually the true statement. So, because Door B is the true statement, Door A is false and the tiger is actually behind it. Therefore, the peasant should pick Door B.

Vocabulary

Logic is the study of reasoning. **Deductive reasoning** draws conclusions from facts.

Guided Practice

1. Here are two true statements.

If $\angle A$ and $\angle B$ are a linear pair, then $m\angle A + m\angle B = 180^\circ$.

$\angle ABC$ and $\angle CBD$ are a linear pair.

What conclusion can you draw from this?

2. Determine the conclusion from the true statements below.

If you are not in Chicago, then you can't be on the L.

Bill is in Chicago.

3. Determine the conclusion from the true statements below.

If you are not in Chicago, then you can't be on the L.

Sally is on the L.

Answers:

1. This is an example of the Law of Detachment, therefore:

$$m\angle ABC + m\angle CBD = 180^\circ$$

2. If we were to rewrite this symbolically, it would look like:

$$\begin{array}{c} \sim p \rightarrow \sim q \\ p \end{array}$$

This is not in the form of the Law of Contrapositive or the Law of Detachment, so there is no logical conclusion. You cannot conclude that Bill is on the *L* because he could be anywhere in Chicago. This is an example of the *Inverse Error* because the second statement is the negation of the hypothesis, like the beginning of the inverse of a statement.

3. If we were to rewrite this symbolically, it would look like:

$$\begin{array}{c} \sim p \rightarrow \sim q \\ q \end{array}$$

Even though it looks a little different, this is an example of the Law of Contrapositive. Therefore, the logical conclusion is: *Sally is in Chicago*.

Practice

Determine the logical conclusion and state which law you used (Law of Detachment, Law of Contrapositive, or Law of Syllogism). If no conclusion can be drawn, write “no conclusion.”

1. People who vote for Jane Wannabe are smart people. I voted for Jane Wannabe.
2. If Rae is the driver today then Maria is the driver tomorrow. Ann is the driver today.
3. If a shape is a circle, then it never ends. If it never ends, then it never starts. If it never starts, then it doesn't exist. If it doesn't exist, then we don't need to study it.
4. If you text while driving, then you are unsafe. You are a safe driver.
5. If you wear sunglasses, then it is sunny outside. You are wearing sunglasses.
6. If you wear sunglasses, then it is sunny outside. It is cloudy.
7. I will clean my room if my mom asks me to. I am not cleaning my room.
8. If I go to the park, I bring my dog. If I bring my dog, we play fetch with a stick. If we play fetch, my dog gets dirty. If my dog gets dirty, I give him a bath.
9. Write the symbolic representation of #3. Include your conclusion. Is this a sound argument? Does it make sense?
10. Write the symbolic representation of #1. Include your conclusion.
11. Write the symbolic representation of #7. Include your conclusion.

For questions 12 and 13, rearrange the order of the statements (you may need to use the Law of Contrapositive too) to discover the logical conclusion.

12. If I shop, then I will buy shoes. If I don't shop, then I didn't go to the mall. If I need a new watch battery, then I go to the mall.

13. If Anna's parents don't buy her ice cream, then she didn't get an *A* on her test. If Anna's teacher gives notes, Anna writes them down. If Anna didn't get an *A* on her test, then she couldn't do the homework. If Anna writes down the notes, she can do the homework.

Determine if the problems below represent inductive or deductive reasoning. Briefly explain your answer.

14. John is watching the weather. As the day goes on it gets more and more cloudy and cold. He concludes that it is going to rain.
15. Beth's 2-year-old sister only eats hot dogs, blueberries and yogurt. Beth decides to give her sister some yogurt because she is hungry.
16. Nolan Ryan has the most strikeouts of any pitcher in Major League Baseball. Jeff debates that he is the best pitcher of all-time for this reason.
17. Ocean currents and waves are dictated by the weather and the phase of the moon. Surfers use this information to determine when it is a good time to hit the water.
18. As Rich is driving along the 405, he notices that as he gets closer to LAX the traffic slows down. As he passes it, it speeds back up. He concludes that anytime he drives past an airport, the traffic will slow down.
19. Amani notices that the milk was left out on the counter. Amani remembers that she put it away after breakfast so it couldn't be her who left it out. She also remembers hearing her mother tell her brother on several occasions to put the milk back in the refrigerator. She concludes that he must have left it out.
20. At a crime scene, the DNA of four suspects is found to be present. However, three of them have an alibi for the time of the crime. The detectives conclude that the fourth possible suspect must have committed the crime.

2.6 Truth Tables

Here you'll learn how to use a truth table to analyze logic.

What if you needed to analyze a complex logical argument? How could you do this in an organized way, making sure to account for everything? After completing this Concept, you'll be able to use truth tables as a way to organize and analyze logic.

Watch This



MEDIA

Click image to the left for more content.

[CK-12 Foundation: Chapter2TruthTablesA](#)

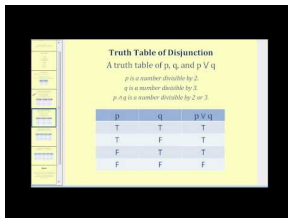

MEDIA

Click image to the left for more content.

[James Sousa:Truth Tables](#)

Guidance

So far we know these symbols for logic:

- \sim not (negation)
- \rightarrow if-then
- \therefore therefore

Two more symbols are:

- \wedge and
- \vee or

We would write “ p and q ” as $p \wedge q$ and “ p or q ” as $p \vee q$.

Truth tables use these symbols and are another way to analyze logic. First, let’s relate p and $\sim p$. To make it easier, set p as: *An even number*. Therefore, $\sim p$ is *An odd number*. Make a truth table to find out if they are both true. Begin with all the “truths” of p , true (T) or false (F).

TABLE 2.5:

p
 T
 F

Next we write the corresponding truth values for $\sim p$. $\sim p$ has the opposite truth values of p . So, if p is true, then $\sim p$ is false and vice versa.

TABLE 2.6:

| | |
|-----|----------|
| p | $\sim p$ |
| T | F |
| F | T |

To Recap:

- Start truth tables with all the possible combinations of truths. For 2 variables there are 4 combinations for 3 variables there are 8. **You always start a truth table this way.**
- Do any negations on the any of the variables.
- Do any combinations in parenthesis.
- Finish with completing what the problem was asking for.

Example A

Draw a truth table for p, q and $p \wedge q$.

First, make columns for p and q . Fill the columns with all the possible true and false combinations for the two.

TABLE 2.7:

| | |
|-----|-----|
| p | q |
| T | T |
| T | F |
| F | T |
| F | F |

Notice all the combinations of p and q . **Anytime we have truth tables with two variables, this is always how we fill out the first two columns.**

Next, we need to figure out when $p \wedge q$ is true, based upon the first two columns. $p \wedge q$ can only be true if **BOTH p and q are true**. So, the completed table looks like this:

| | | | |
|-----|-----|--------------|---|
| p | q | $p \wedge q$ | |
| T | T | T | p and q are true , $p \wedge q$ is true . |
| T | F | F | p or q are true , $p \wedge q$ is false . |
| F | T | F | p or q are true , $p \wedge q$ is false . |
| F | F | F | p and q are false , $p \wedge q$ is false . |

This is how a truth table with two variables and their “and” column is always filled out.

Example B

Draw a truth table for p, q and $p \vee q$.

First, make columns for p and q , just like Example A.

TABLE 2.8:

| | |
|-----|-----|
| p | q |
| T | T |
| T | F |
| F | T |
| F | F |

Next, we need to figure out when $p \vee q$ is true, based upon the first two columns. $p \vee q$ is true if p OR q are true, or both are true. So, the completed table looks like this:

| p | q | $p \vee q$ | |
|-----|-----|------------|--|
| T | T | T | <div style="border: 1px solid black; padding: 5px; display: inline-block;"> <p>p and q are true, $p \vee q$ is true.</p> </div> |
| T | F | T | <div style="border: 1px solid black; padding: 5px; display: inline-block;"> <p>p or q are true, $p \vee q$ is true.</p> </div> |
| F | T | T | <div style="border: 1px solid black; padding: 5px; display: inline-block;"> <p>p or q are true, $p \vee q$ is true.</p> </div> |
| F | F | F | <div style="border: 1px solid black; padding: 5px; display: inline-block;"> <p>p and q are false, $p \vee q$ is false.</p> </div> |

The difference between $p \wedge q$ and $p \vee q$ is the second and third rows. For “and” both p and q have to be true, but for “or” only one has to be true.

Example C

Determine the truths for $p \wedge (\sim q \vee r)$.

First, there are three variables, so we are going to need all the combinations of their truths. **For three variables, there are always 8 possible combinations.**

TABLE 2.9:

| | | |
|-----|-----|-----|
| p | q | r |
| T | T | T |
| T | T | F |
| T | F | T |
| T | F | F |
| F | T | T |
| F | T | F |
| F | F | T |
| F | F | F |

Next, address the $\sim q$. It will just be the opposites of the q column.

TABLE 2.10:

| p | q | r | $\sim q$ |
|-----|-----|-----|----------|
| T | T | T | F |
| T | T | F | F |
| T | F | T | T |
| T | F | F | T |
| F | T | T | F |
| F | T | F | F |
| F | F | T | T |
| F | F | F | T |

Now, let's do what's in the parenthesis, $\sim q \vee r$. Remember, for "or" only $\sim q$ OR r has to be true. Only use the $\sim q$ and r columns to determine the values in this column.

TABLE 2.11:

| p | q | r | $\sim q$ | $\sim q \vee r$ |
|-----|-----|-----|----------|-----------------|
| T | T | T | F | T |
| T | T | F | F | F |
| T | F | T | T | T |
| T | F | F | T | T |
| F | T | T | F | T |
| F | T | F | F | F |
| F | F | T | T | T |
| F | F | F | T | T |

Finally, we can address the entire problem, $p \wedge (\sim q \vee r)$. Use the p and $\sim q \vee r$ to determine the values. Remember, for "and" both p and $\sim q \vee r$ must be true.

TABLE 2.12:

| p | q | r | $\sim q$ | $\sim q \vee r$ | $p \wedge (\sim q \vee r)$ |
|-----|-----|-----|----------|-----------------|----------------------------|
| T | T | T | F | T | T |
| T | T | F | F | F | F |
| T | F | T | T | T | T |
| T | F | F | T | T | T |
| F | T | T | F | T | F |
| F | T | F | F | F | F |
| F | F | T | T | T | F |
| F | F | F | T | T | F |

Watch this video for help with the Examples above.



MEDIA

Click image to the left for more content.

Vocabulary

Truth tables use symbols to analyze logic.

Guided Practice

Write a truth table for the following variables.

- $p \wedge \sim p$
- $\sim p \vee \sim q$
- $p \wedge (q \vee \sim q)$

Answers:

- First, make columns for p , then add in $\sim p$ and finally, evaluate $p \wedge \sim p$.

TABLE 2.13:

| p | $\sim p$ | $p \wedge \sim p$ |
|-----|----------|-------------------|
| T | F | F |
| F | T | F |

- First, make columns for p and q , then add in $\sim p$ and $\sim q$. Finally, evaluate $\sim p \vee \sim q$.

TABLE 2.14:

| p | q | $\sim p$ | $\sim q$ | $\sim p \vee \sim q$ |
|-----|-----|----------|----------|----------------------|
| T | T | F | F | F |
| T | F | F | T | T |
| F | T | T | F | T |
| F | F | T | T | T |

- First, make columns for p and q , then add in $\sim q$ and $q \vee \sim q$. Finally, evaluate $p \wedge (q \vee \sim q)$.

TABLE 2.15:

| p | q | $\sim q$ | $(q \vee \sim q)$ | $p \wedge (q \vee \sim q)$ |
|-----|-----|----------|-------------------|----------------------------|
| T | T | F | T | T |
| T | F | T | T | T |
| F | T | F | T | F |
| F | F | T | T | F |

Practice

Write a truth table for the following variables.

- $(p \wedge q) \vee \sim r$
- $p \vee (\sim q \vee r)$
- $p \wedge (q \vee \sim r)$
- The only difference between #1 and #3 is the placement of the parenthesis. How do the truth tables differ?
- When is $p \vee q \vee r$ true?
- $p \vee q \vee r$

7. $(p \vee q) \vee \sim r$
8. $(\sim p \wedge \sim q) \wedge r$
9. $(\sim p \vee \sim q) \wedge r$

Is the following a valid argument? If so, what law is being used? HINT: Statements could be out of order.

10.

$$\begin{array}{l} p \rightarrow q \\ r \rightarrow p \\ \therefore r \rightarrow q \end{array}$$

11.

$$\begin{array}{l} p \rightarrow q \\ r \rightarrow q \\ \therefore p \rightarrow r \end{array}$$

12.

$$\begin{array}{l} p \rightarrow \sim r \\ r \\ \therefore \sim p \end{array}$$

13.

$$\begin{array}{l} \sim q \rightarrow r \\ q \\ \therefore \sim r \end{array}$$

14.

$$\begin{array}{l} p \rightarrow (r \rightarrow s) \\ p \\ \therefore r \rightarrow s \end{array}$$

15.

$$\begin{array}{l} r \rightarrow q \\ r \rightarrow s \\ \therefore q \rightarrow s \end{array}$$

2.7 Properties of Equality and Congruence

Here you'll review the properties of equality you learned in previous concepts, be introduced to the properties of congruence, and learn how to use these properties.

What if you wanted to solve an equation and justify each step? What mathematical properties could you use in your justification? After completing this Concept, you be able to see how the properties of equality from Algebra I relate to geometric properties of congruence.

Watch This



MEDIA
Click image to the left for more content.

[CK-12 Foundation: Chapter2PropertiesofEqualityandCongruenceA](#)

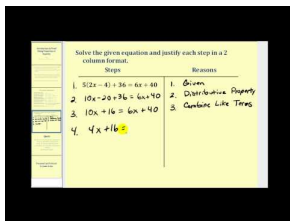

MEDIA
Click image to the left for more content.

[James Sousa:Introduction toProof UsingProperties of Equality](#)

Guidance

The basic properties of equality were introduced to you in Algebra I. Here they are again:

For all real numbers $a, b,$ and c :

TABLE 2.16:

Reflexive Property of Equality

$$a = a$$

Symmetric Property of Equality

$$a = b \text{ and } b = a$$

Transitive Property of Equality

$$a = b \text{ and } b = c, \text{ then } a = c$$

Substitution Property of Equality

If $a = b$, then b can be used in place of a and vice versa.

Addition Property of Equality

$$\text{If } a = b, \text{ then } a + c = b + c.$$

Subtraction Property of Equality

$$\text{If } a = b, \text{ then } a - c = b - c.$$

Examples

$$25 = 25$$

$$m\angle P = 90^\circ \text{ or } 90^\circ = m\angle P$$

$$a + 4 = 10 \text{ and } 10 = 6 + 4, \text{ then } a + 4 = 6 + 4$$

$$\text{If } a = 9 \text{ and } a - c = 5, \text{ then } 9 - c = 5$$

$$\text{If } 2x = 6, \text{ then } 2x + 5 = 6 + 5$$

$$\text{If } m\angle x + 15^\circ = 65^\circ, \text{ then } m\angle x + 15^\circ - 15^\circ = 65^\circ - 15^\circ$$

TABLE 2.16: (continued)

| | | <i>Examples</i> |
|--|---|---|
| Multiplication Property of Equality | If $a = b$, then $ac = bc$. | If $y = 8$, then $5 \cdot y = 5 \cdot 8$ |
| Division Property of Equality | If $a = b$, then $\frac{a}{c} = \frac{b}{c}$. | If $3b = 18$, then $\frac{3b}{3} = \frac{18}{3}$ |
| Distributive Property | $a(b + c) = ab + ac$ | $5(2x - 7) = 5(2x) - 5(7) = 10x - 35$ |

Recall that $\overline{AB} \cong \overline{CD}$ if and only if $AB = CD$. \overline{AB} and \overline{CD} represent segments, while AB and CD are lengths of those segments, which means that AB and CD are numbers. The properties of equality apply to AB and CD .

This also holds true for angles and their measures. $\angle ABC \cong \angle DEF$ if and only if $m\angle ABC = m\angle DEF$. Therefore, the properties of equality apply to $m\angle ABC$ and $m\angle DEF$.

Just like the properties of equality, there are properties of congruence. These properties hold for figures and shapes.

TABLE 2.17:

| | <i>For Line Segments</i> | <i>For Angles</i> |
|--|---|---|
| Reflexive Property of Congruence | $\overline{AB} \cong \overline{AB}$ | $\angle ABC \cong \angle CBA$ |
| Symmetric Property of Congruence | If $\overline{AB} \cong \overline{CD}$, then $\overline{CD} \cong \overline{AB}$ | If $\angle ABC \cong \angle DEF$, then $\angle DEF \cong \angle ABC$ |
| Transitive Property of Congruence | If $\overline{AB} \cong \overline{CD}$ and $\overline{CD} \cong \overline{EF}$, then $\overline{AB} \cong \overline{EF}$ | If $\angle ABC \cong \angle DEF$ and $\angle DEF \cong \angle GHI$, then $\angle ABC \cong \angle GHI$ |

When you solve equations in algebra you use properties of equality. You might not write out the logical justification for each step in your solution, but you should know that there is an equality property that justifies that step. We will abbreviate “Property of Equality” “PoE” and “Property of Congruence” “PoC.”

Example A

Solve $2(3x - 4) + 11 = x - 27$ and justify each step.

| | |
|--------------------------------|-----------------------|
| $2(3x - 4) + 11 = x - 27$ | |
| $6x - 8 + 11 = x - 27$ | Distributive Property |
| $6x + 3 = x - 27$ | Combine like terms |
| $6x + 3 - 3 = x - 27 - 3$ | Subtraction PoE |
| $6x = x - 30$ | Simplify |
| $6x - x = x - x - 30$ | Subtraction PoE |
| $5x = -30$ | Simplify |
| $\frac{5x}{5} = \frac{-30}{5}$ | Division PoE |
| $x = -6$ | Simplify |

Example B

Given points A , B , and C , with $AB = 8$, $BC = 17$, and $AC = 20$. Are A , B , and C collinear?

Set up an equation using the Segment Addition Postulate.

| | |
|----------------|----------------------------|
| $AB + BC = AC$ | Segment Addition Postulate |
| $8 + 17 = 20$ | Substitution PoE |
| $25 \neq 20$ | Combine like terms |

Because the two sides are not equal, A , B and C are not collinear.

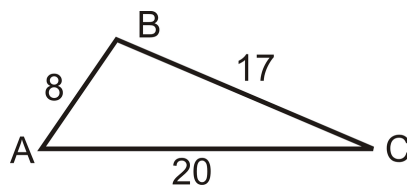

Example C

If $m\angle A + m\angle B = 100^\circ$ and $m\angle B = 40^\circ$, prove that $\angle A$ is an acute angle.

We will use a two-column format, with statements in one column and their corresponding reasons in the next. This is formally called a two-column proof.

TABLE 2.18:

| <i>Statement</i> | <i>Reason</i> |
|---|---|
| 1. $m\angle A + m\angle B = 100^\circ$ and $m\angle B = 40^\circ$ | Given (always the reason for using facts that are told to us in the problem) |
| 2. $m\angle A + 40^\circ = 100^\circ$ | Substitution PoE |
| 3. $m\angle A = 60^\circ$ | Subtraction PoE |
| 4. $\angle A$ is an acute angle | Definition of an acute angle, $m\angle A < 90^\circ$ |

Watch this video for help with the Examples above.



MEDIA

Click image to the left for more content.

[CK-12 Foundation: Chapter2PropertiesofEqualityandCongruenceB](#)

Vocabulary

The *properties of equality* and *properties of congruence* are the logical rules that allow equations to be manipulated and solved.

Guided Practice

Use the given property or properties of equality to fill in the blank. x , y , and z are real numbers.

1. Symmetric: If $x = 3$, then _____.

2. Distributive: If $4(3x - 8)$, then _____.

3. Transitive: If $y = 12$ and $x = y$, then _____.

Answers:

1. $3 = x$

2. $12x - 32$

3. $x = 12$

Practice

For questions 1-8, solve each equation and justify each step.

1. $3x + 11 = -16$

2. $7x - 3 = 3x - 35$

3. $\frac{2}{3}g + 1 = 19$

4. $\frac{1}{2}MN = 5$

5. $5m\angle ABC = 540^\circ$

6. $10b - 2(b + 3) = 5b$

7. $\frac{1}{4}y + \frac{5}{6} = \frac{1}{3}$

8. $\frac{1}{4}AB + \frac{1}{3}AB = 12 + \frac{1}{2}AB$

For questions 9-12, use the given property or properties of equality to fill in the blank. $x, y,$ and z are real numbers.

9. Symmetric: If $x + y = y + z$, then _____.

10. Transitive: If $AB = 5$ and $AB = CD$, then _____.

11. Substitution: If $x = y - 7$ and $x = z + 4$, then _____.

12. Distributive: If $3(2x - 4) = y$, then _____.

13. Given points $E, F,$ and G and $EF = 16, FG = 7$ and $EG = 23$. Determine if E, F and G are collinear.

14. Given points H, I and J and $HI = 9, IJ = 9$ and $HJ = 16$. Are the three points collinear? Is I the midpoint?

15. If $m\angle KLM = 56^\circ$ and $m\angle KLM + m\angle NOP = 180^\circ$, explain how $\angle NOP$ must be an obtuse angle.

2.8 Two-Column Proofs

Here you'll learn how to write a two-column geometric proof.

What if you wanted to prove that two angles are congruent? After completing this Concept, you'll be able to formally prove geometric ideas with two-column proofs.

Watch This



MEDIA

Click image to the left for more content.

[CK-12 Foundation: Chapter2TwoColumnProofsA](#)

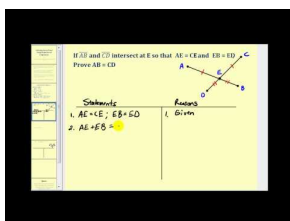

MEDIA

Click image to the left for more content.

[James Sousa:Introduction toProof UsingProperties of Congruence](#)

Guidance

A **two-column proof** is one common way to organize a proof in geometry. Two-column proofs always have two columns- statements and reasons. The best way to understand two-column proofs is to read through examples.

When writing your own two-column proof, keep these things in mind:

- **Number each step.**
- **Start with the given information.**
- **Statements with the same reason can be combined into one step.** It is up to you.
- **Draw a picture and mark it with the given information.**
- **You must have a reason for EVERY statement.**
- **The order of the statements in the proof is not always fixed, but make sure the order makes logical sense.**
- **Reasons will be definitions, postulates, properties and previously proven theorems.** “Given” is only used as a reason if the information in the statement column was told in the problem.
- **Use symbols and abbreviations for words within proofs.** For example, \cong can be used in place of the word *congruent*. You could also use \angle for the word angle.

Example A

Write a two-column proof for the following:

If $A, B, C,$ and D are points on a line, in the given order, and $AB = CD,$ then $AC = BD.$

First of all, when the statement is given in this way, the “if” part is the given and the “then” part is what we are trying to prove.

Always start with drawing a picture of what you are given.

Plot the points in the order A, B, C, D on a line.



Add the corresponding markings, $AB = CD,$ to the line.



Draw the two-column proof and start with the given information. From there, we can use deductive reasoning to reach the next statement and what we want to prove. **Reasons will be definitions, postulates, properties and previously proven theorems.**

TABLE 2.19:

| <i>Statement</i> | <i>Reason</i> |
|---|-----------------------------------|
| 1. $A, B, C,$ and D are collinear, in that order. | 1. Given |
| 2. $AB = CD$ | 2. Given |
| 3. $BC = BC$ | 3. Reflexive PoE |
| 4. $AB + BC = BC + CD$ | 4. Addition PoE |
| 5. $AB + BC = AC, BC + CD = BD$ | 5. Segment Addition Postulate |
| 6. $AC = BD$ | 6. Substitution or Transitive PoE |

When you reach what it is that you wanted to prove, you are done.

Example B

Write a two-column proof.

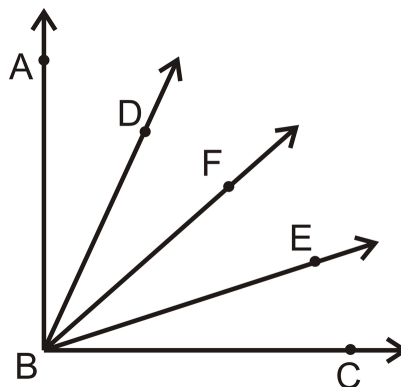

Given: \vec{BF} bisects $\angle ABC$; $\angle ABD \cong \angle CBE$

Prove: $\angle DBF \cong \angle EBF$

First, put the appropriate markings on the picture. Recall, that bisect means “to cut in half.” Therefore, if \vec{BF} bisects $\angle ABC$, then $m\angle ABF = m\angle FBC$. Also, because the word “bisect” was used in the given, the definition will probably be used in the proof.

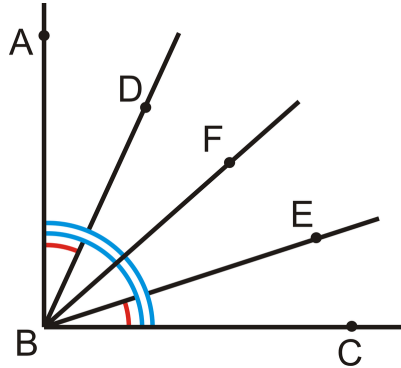

TABLE 2.20:

| Statement | Reason |
|--|---|
| 1. \vec{BF} bisects $\angle ABC$, $\angle ABD \cong \angle CBE$ | 1. Given |
| 2. $m\angle ABF = m\angle FBC$ | 2. Definition of an Angle Bisector |
| 3. $m\angle ABD = m\angle CBE$ | 3. If angles are \cong , then their measures are equal. |
| 4. $m\angle ABF = m\angle ABD + m\angle DBF$, $m\angle FBC = m\angle EBF + m\angle CBE$ | 4. Angle Addition Postulate |
| 5. $m\angle ABD + m\angle DBF = m\angle EBF + m\angle CBE$ | 5. Substitution PoE |
| 6. $m\angle ABD + m\angle DBF = m\angle EBF + m\angle ABD$ | 6. Substitution PoE |
| 7. $m\angle DBF = m\angle EBF$ | 7. Subtraction PoE |
| 8. $\angle DBF \cong \angle EBF$ | 8. If measures are equal, the angles are \cong . |

Example C

The **Right Angle Theorem** states that if two angles are right angles, then the angles are congruent. Prove this theorem.

To prove this theorem, set up your own drawing and name some angles so that you have specific angles to talk about.

Given: $\angle A$ and $\angle B$ are right angles

Prove: $\angle A \cong \angle B$

TABLE 2.21:

| Statement | Reason |
|--|-----------------------------------|
| 1. $\angle A$ and $\angle B$ are right angles | 1. Given |
| 2. $m\angle A = 90^\circ$ and $m\angle B = 90^\circ$ | 2. Definition of right angles |
| 3. $m\angle A = m\angle B$ | 3. Transitive PoE |
| 4. $\angle A \cong \angle B$ | 4. \cong angles have = measures |

Any time right angles are mentioned in a proof, you will need to use this theorem to say the angles are congruent.

Example D

The **Same Angle Supplements Theorem** states that if two angles are supplementary to the same angle then the two angles are congruent. Prove this theorem.

Given: $\angle A$ and $\angle B$ are supplementary angles. $\angle B$ and $\angle C$ are supplementary angles.

Prove: $\angle A \cong \angle C$

TABLE 2.22:

| <i>Statement</i> | <i>Reason</i> |
|---|---------------------------------------|
| 1. $\angle A$ and $\angle B$ are supplementary $\angle B$ and $\angle C$ are supplementary | 1. Given |
| 2. $m\angle A + m\angle B = 180^\circ$ $m\angle B + m\angle C = 180^\circ$ | 2. Definition of supplementary angles |
| 3. $m\angle A + m\angle B = m\angle B + m\angle C$ | 3. Substitution <i>PoE</i> |
| 4. $m\angle A = m\angle C$ | 4. Subtraction <i>PoE</i> |
| 5. $\angle A \cong \angle C$ | 5. \cong angles have = measures |

Example E

The **Vertical Angles Theorem** states that vertical angles are congruent. Prove this theorem.

Given: Lines k and m intersect.

Prove: $\angle 1 \cong \angle 3$

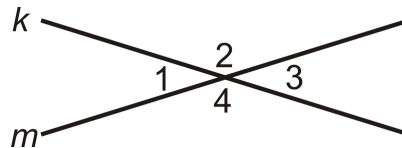
**TABLE 2.23:**

| <i>Statement</i> | <i>Reason</i> |
|---|---------------------------------------|
| 1. Lines k and m intersect | 1. Given |
| 2. $\angle 1$ and $\angle 2$ are a linear pair $\angle 2$ and $\angle 3$ are a linear pair | 2. Definition of a Linear Pair |
| 3. $\angle 1$ and $\angle 2$ are supplementary $\angle 2$ and $\angle 3$ are supplementary | 3. Linear Pair Postulate |
| 4. $m\angle 1 + m\angle 2 = 180^\circ$ $m\angle 2 + m\angle 3 = 180^\circ$ | 4. Definition of Supplementary Angles |
| 5. $m\angle 1 + m\angle 2 = m\angle 2 + m\angle 3$ | 5. Substitution <i>PoE</i> |
| 6. $m\angle 1 = m\angle 3$ | 6. Subtraction <i>PoE</i> |
| 7. $\angle 1 \cong \angle 3$ | 7. \cong angles have = measures |

Watch this video for help with the Examples above.



MEDIA

Click image to the left for more content.

CK-12 Foundation: Chapter2TwoColumnProofsB

Vocabulary

A **two-column proof** is one common way to organize a proof in geometry. Two-column proofs always have two columns: statements and reasons.

Guided Practice

1. Write a two-column proof for the following:

Given: $\overline{AC} \perp \overline{BD}$ and $\angle 1 \cong \angle 4$

Prove: $\angle 2 \cong \angle 3$

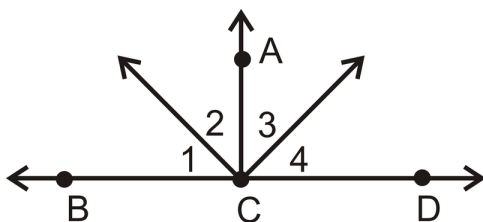

2. Write a two-column proof for the following:

Given: $\angle L$ is supplementary to $\angle M$, $\angle P$ is supplementary to $\angle O$, $\angle L \cong \angle O$

Prove: $\angle P \cong \angle M$

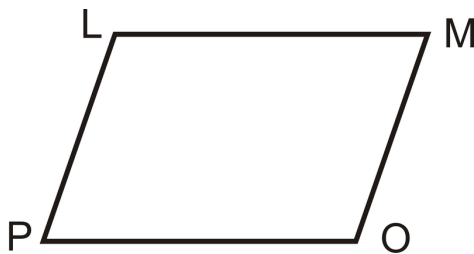

Answers:

1.

TABLE 2.24:

Statement

1. $\overline{AC} \perp \overline{BD}$
2. $\angle BCA$ and $\angle DCA$ are right angles
3. $\angle BCA \cong \angle DCA$
4. $\angle 1 \cong \angle 4$
5. $\angle 2 \cong \angle 3$

Reason

1. Given
2. Definition of a Perpendicular Lines
3. Right Angle Theorem
4. Given
5. Subtraction *PoE*

2.

TABLE 2.25:

| <i>Statement</i> | <i>Reason</i> |
|--|---------------------------------------|
| 1. $\angle L$ is supplementary to $\angle M$, $\angle P$ is supplementary to $\angle O$ | 1. Given |
| 2. $\angle L + \angle M = 180$, $\angle P + \angle O = 180$ | 2. Definition of Supplementary Angles |
| 3. $\angle L + \angle M = \angle P + \angle O$ | 3. Substitution <i>PoE</i> |
| 4. $\angle L \cong \angle O$ | 4. Given |
| 5. $\angle O + \angle M = \angle P + \angle O$ | 5. Substitution <i>PoE</i> |
| 6. $\angle M = \angle P$ | 6. Subtraction <i>PoE</i> |

Practice

Write a two-column proof for questions 1-5.

- 1.
- Given:
- $\angle MLN \cong \angle OLP$
- Prove:
- $\angle MLO \cong \angle NLP$

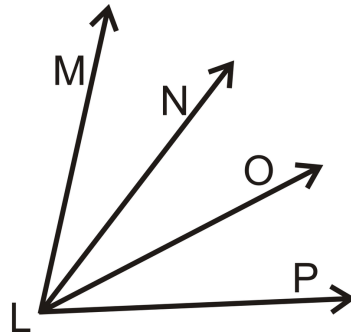

- 2.
- Given:
- $\overline{AE} \perp \overline{EC}$
- and
- $\overline{BE} \perp \overline{ED}$
- Prove:
- $\angle 1 \cong \angle 3$

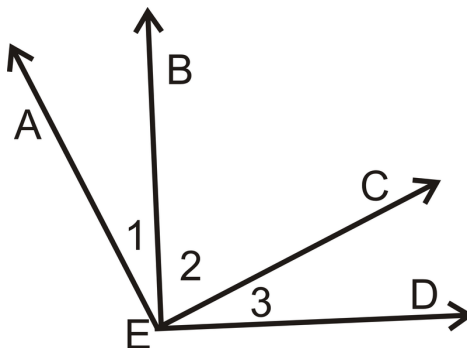

- 3.
- Given:
- $\angle 1 \cong \angle 4$
- Prove:
- $\angle 2 \cong \angle 3$

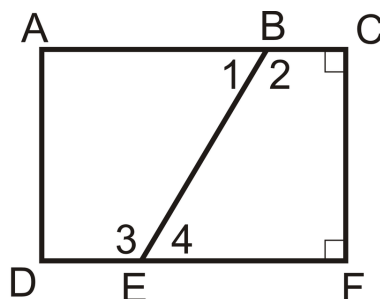

- 4.
- Given:
- $l \perp m$
- Prove:
- $\angle 1 \cong \angle 2$

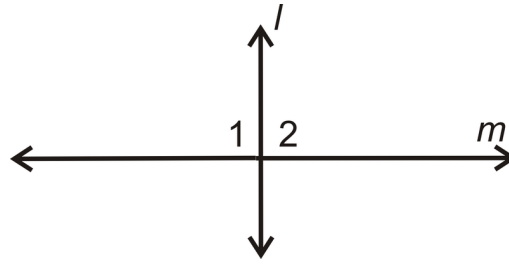

5. Given: $l \perp m$ Prove: $\angle 1$ and $\angle 2$ are complements

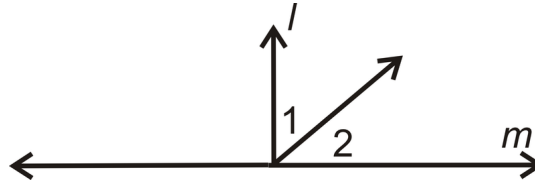

Use the picture for questions 6-15.

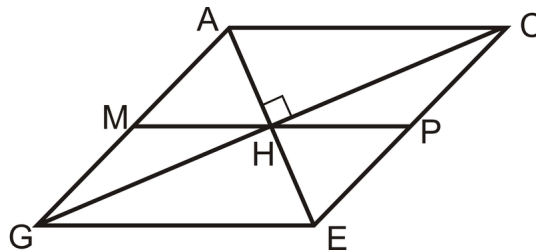

Given: H is the midpoint of \overline{AE} , \overline{MP} and \overline{GC}

M is the midpoint of \overline{GA}

P is the midpoint of \overline{CE}

$\overline{AE} \perp \overline{GC}$

6. List two pairs of vertical angles.
7. List all the pairs of congruent segments.
8. List two linear pairs that do not have H as the vertex.
9. List a right angle.
10. List two pairs of adjacent angles that are NOT linear pairs.
11. What is the perpendicular bisector of \overline{AE} ?
12. List two bisectors of \overline{MP} .
13. List a pair of complementary angles.
14. If \overline{GC} is an angle bisector of $\angle AGE$, what two angles are congruent?
15. Fill in the blanks for the proof below.

Given: Picture above and $\angle ACH \cong \angle ECH$

Prove: \overline{CH} is the angle bisector of $\angle ACE$

TABLE 2.26:

| <i>Statement</i> | <i>Reason</i> |
|--|---------------|
| 1. $\angle ACH \cong \angle ECH$ | 1. |
| \overline{CH} is on the interior of $\angle ACE$ | |

TABLE 2.26: (continued)

| <i>Statement</i> | <i>Reason</i> |
|---------------------------------|-----------------------------|
| 2. $m\angle ACH = m\angle ECH$ | 2. |
| 3. | 3. Angle Addition Postulate |
| 4. | 4. Substitution |
| 5. $m\angle ACE = 2m\angle ACH$ | 5. |
| 6. | 6. Division PoE |
| 7. | 7. |

Summary

This chapter teaches students how to make conjectures and provide counterexamples. From there, it focuses on rewriting statements in if-then form and finding converses, inverses, and contrapositives. Two types of reasoning, inductive and deductive, are explored. Finally, the properties of equality and congruence are reviewed and practice for completing two-column proofs is provided.

Symbol Toolbox for Chapter

\rightarrow if-then

\wedge and

\therefore therefore

\sim not

\vee or

Chapter Keywords

- Inductive Reasoning
- Conjecture
- Counterexample
- Conditional Statement (If-Then Statement)
- Hypothesis
- Conclusion
- Converse
- Inverse
- Contrapositive
- Biconditional Statement
- Logic
- Deductive Reasoning
- Law of Detachment
- Law of Contrapositive
- Law of Syllogism
- Right Angle Theorem
- Same Angle Supplements Theorem
- Same Angle Complements Theorem
- Reflexive Property of Equality
- Symmetric Property of Equality

- Transitive Property of Equality
- Substitution Property of Equality
- Addition Property of Equality
- Subtraction Property of Equality
- Multiplication Property of Equality
- Division Property of Equality
- Distributive Property
- Reflexive Property
- of Congruence
- Symmetric Property
- of Congruence
- Transitive Property of Congruence

Chapter Review

Match the definition or description with the correct word.

1. $5 = x$ and $y + 4 = x$, then $5 = y + 4$ — A. Law of Contrapositive
2. An educated guess — B. Inductive Reasoning
3. $6(2a + 1) = 12a + 12$ — C. Inverse
4. 2, 4, 8, 16, 32,... — D. Transitive Property of Equality
5. $\overline{AB} \cong \overline{CD}$ and $\overline{CD} \cong \overline{AB}$ — E. Counterexample
6. $\sim p \rightarrow \sim q$ — F. Conjecture
7. Conclusions drawn from facts. — G. Deductive Reasoning
8. If I study, I will get an “A” on the test. I did not get an A. Therefore, I didn’t study. — H. Distributive Property
9. $\angle A$ and $\angle B$ are right angles, therefore $\angle A \cong \angle B$. — I. Symmetric Property of Congruence
10. 2 disproves the statement: “All prime numbers are odd.” — J. Right Angle Theorem — K. Definition of Right Angles

Texas Instruments Resources

In the CK-12 Texas Instruments Geometry FlexBook, there are graphing calculator activities designed to supplement the objectives for some of the lessons in this chapter. See <http://www.ck12.org/flexr/chapter/9687>.

Parallel and Perpendicular Lines

Chapter Outline

- 3.1 PARALLEL AND SKEW LINES
 - 3.2 PERPENDICULAR LINES
 - 3.3 CORRESPONDING ANGLES
 - 3.4 ALTERNATE INTERIOR ANGLES
 - 3.5 ALTERNATE EXTERIOR ANGLES
 - 3.6 SAME SIDE INTERIOR ANGLES
 - 3.7 SLOPE IN THE COORDINATE PLANE
 - 3.8 PARALLEL LINES IN THE COORDINATE PLANE
 - 3.9 PERPENDICULAR LINES IN THE COORDINATE PLANE
 - 3.10 DISTANCE FORMULA IN THE COORDINATE PLANE
 - 3.11 DISTANCE BETWEEN PARALLEL LINES
-

Introduction

In this chapter, you will explore the different relationships formed by parallel and perpendicular lines and planes. Different angle relationships will also be explored and what happens to these angles when lines are parallel. You will continue to use proofs, to prove that lines are parallel or perpendicular. There will also be a review of equations of lines and slopes and how we show algebraically that lines are parallel and perpendicular.

3.1 Parallel and Skew Lines

Here you'll learn about parallel and skew lines.

What if you were given a pair of lines that never intersect and were asked to describe them? What terminology would you use? After completing this Concept, you will be able to define the terms parallel line, skew line, and transversal. You'll also be able to apply the properties associated with parallel lines.

Watch This



MEDIA

Click image to the left for more content.

[CK-12 Foundation: Chapter3ParallelandSkewLinesA](#)

Watch the portions of this video dealing with parallel lines.

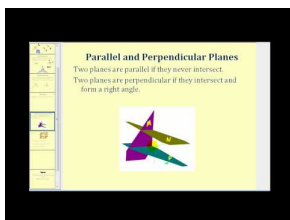

MEDIA

Click image to the left for more content.

[James Sousa:Parallel Lines](#)

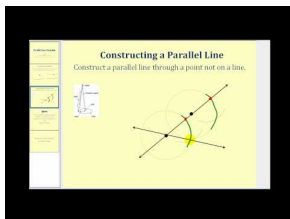

MEDIA

Click image to the left for more content.

[James Sousa:Parallel Line Postulate](#)

Guidance

Two or more lines are **parallel** when they lie in the same plane and never intersect. The symbol for parallel is \parallel . To mark lines parallel, draw arrows ($>$) on each parallel line. If there are more than one pair of parallel lines, use two arrows ($>>$) for the second pair. The two lines below would be labeled $\overleftrightarrow{AB} \parallel \overleftrightarrow{MN}$ or $l \parallel m$.

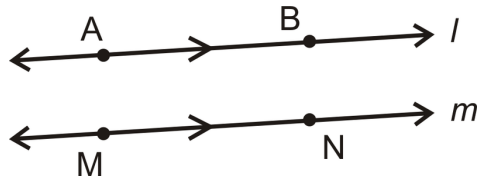

For a line and a point not on the line, there is exactly one line parallel to this line through the point. There are infinitely many lines that pass through A , but only one is parallel to l .

Skew lines are lines that are in different planes and never intersect. The difference between parallel lines and skew lines is parallel lines lie in the same plane while skew lines lie in different planes.

A **transversal** is a line that intersects two distinct lines. These two lines may or may not be parallel. The area between l and m is called the *interior*. The area outside l and m is called the *exterior*.

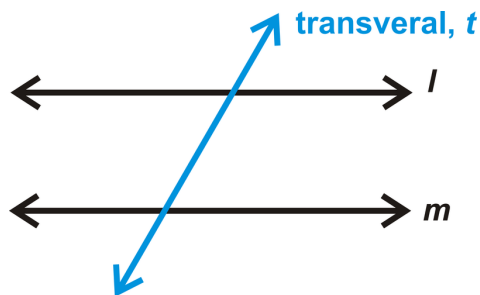

The **Parallel Lines Property** is a transitive property that can be applied to parallel lines. It states that if lines $l \parallel m$ and $m \parallel n$, then $l \parallel n$.

Example A

Are lines q and r parallel?

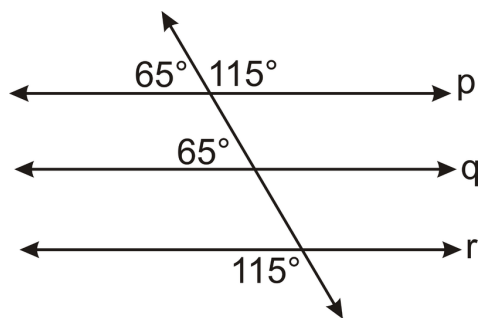

First find if $p \parallel q$, followed by $p \parallel r$. If so, then $q \parallel r$.

$p \parallel q$ by the Converse of the Corresponding Angles Postulate, the corresponding angles are 65° . $p \parallel r$ by the Converse of the Alternate Exterior Angles Theorem, the alternate exterior angles are 115° . Therefore, by the Parallel Lines Property, $q \parallel r$.

Example B

In the cube below, list 3 pairs of parallel planes.

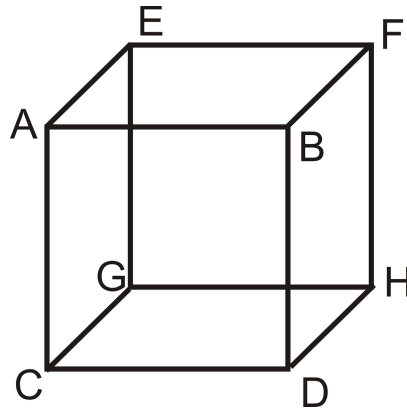

Planes ABC and EFG , Planes AEG and FBH , Planes AEB and CDH

Example C

In the cube below, list 3 pairs of skew line segments.

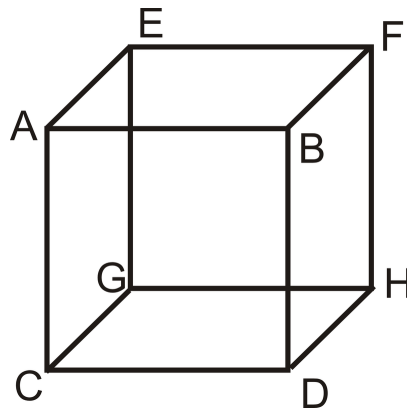

\overline{BD} and \overline{CG} , \overline{BF} and \overline{EG} , \overline{GH} and \overline{AE} (there are others, too)

Watch this video for help with the Examples above.



MEDIA

Click image to the left for more content.

[CK-12 Foundation: Chapter3ParallelandSkewLinesB](#)

Vocabulary

Two or more lines are **parallel** when they lie in the same plane and never intersect. **Skew lines** are lines that are in different planes and never intersect. A **transversal** is a line that intersects two distinct lines.

Guided Practice

Use the figure below to answer the questions. The two pentagons are parallel and all of the rectangular sides are perpendicular to both of them.

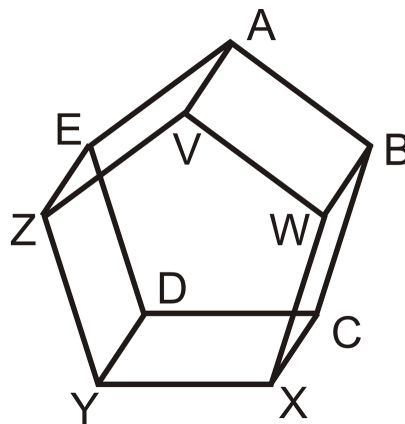

1. Find two pairs of skew lines.
2. List a pair of parallel lines.
3. For \overline{XY} , how many parallel lines would pass through point D ? Name this/these line(s).

Answers:

1. \overline{ZV} and \overline{WB} . \overline{YD} and \overline{VW}
2. \overline{ZV} and \overline{EA} .
3. One line, \overline{CD}

Practice

1. Which of the following is the best example of parallel lines?
 - a. Railroad Tracks
 - b. Lamp Post and a Sidewalk
 - c. Longitude on a Globe
 - d. Stonehenge (the stone structure in Scotland)
2. Which of the following is the best example of skew lines?
 - a. Roof of a Home
 - b. Northbound Freeway and an Eastbound Overpass
 - c. Longitude on a Globe
 - d. The Golden Gate Bridge

For 3-10, determine whether the statement is true or false.

3. If $p \parallel q$ and $q \parallel r$, then $p \parallel r$.
4. Skew lines are never in the same plane.
5. Skew lines can be perpendicular.
6. Planes can be parallel.
7. Parallel lines are never in the same plane.
8. Skew lines never intersect.

9. Skew lines can be in the same plane.
10. Parallel lines can intersect.
11. Come up with your own example of parallel lines in the real world.
12. Come up with your own example of skew lines in the real world.
13. What type of shapes do you know that have parallel line segments in them?
14. What type of objects do you know that have skew line segments in them?
15. If two lines segments are not in the same plane, are they skew?

3.2 Perpendicular Lines

Here you'll learn about perpendicular lines, including their properties and how to construct them.

What if you were given a pair of lines that intersect each other at a right angle? What terminology would you use to describe such lines? After completing this Concept, you will be able to define perpendicular lines. You'll also be able to apply the properties associated with such lines to solve for unknown angles

Watch This



MEDIA

Click image to the left for more content.

CK-12 Foundation: Chapter3PerpendicularLinesA

Watch the portions of this video dealing with perpendicular lines.

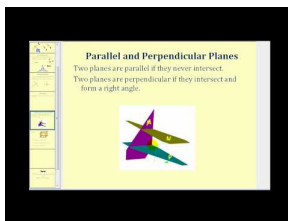

MEDIA

Click image to the left for more content.

James Sousa:Perpendicular Lines

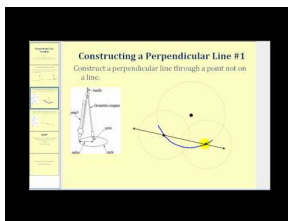

MEDIA

Click image to the left for more content.

James Sousa:Perpendicular Line Postulate

Guidance

Two lines are **perpendicular** if they meet at a 90° , or **right**, angle. For a line and a point not on the line, there is exactly one line perpendicular to the line that passes through the point. There are infinitely many lines that pass through A , but only one that is perpendicular to l . Recall that complementary angles add up to 90° . If complementary angles are adjacent, their nonadjacent sides are perpendicular rays. What you learn about perpendicular lines can also be applied to this situation.

Investigation: Perpendicular Line Construction; through a Point NOT on the Line

1. Draw a horizontal line and a point above that line.

Label the line l and the point A .

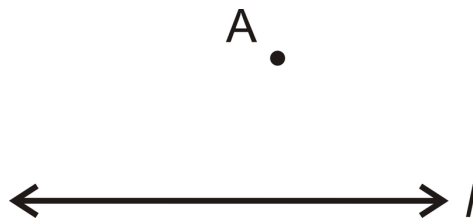

2. Take the compass and put the pointer on A . Open the compass so that it reaches beyond line l . Draw an arc that intersects the line twice.

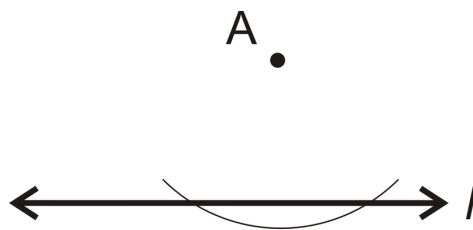

3. Move the pointer to one of the arc intersections. Widen the compass a little and draw an arc below the line. Repeat this on the other side so that the two arc marks intersect.

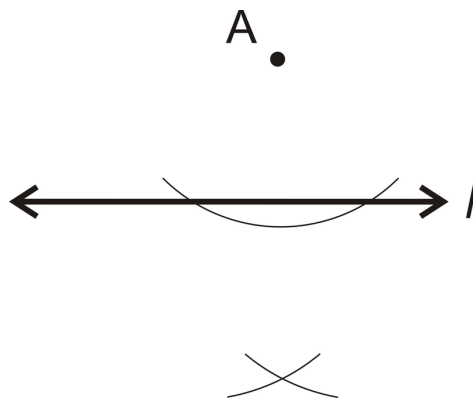

4. Take your straightedge and draw a line from point A to the arc intersections below the line. This line is perpendicular to l and passes through A .

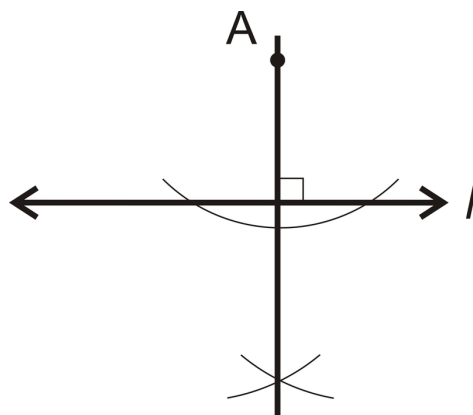

Notice that this is a different construction from a perpendicular bisector.

To see a demonstration of this construction, go to: <http://www.mathsisfun.com/geometry/construct-perpnotline.html>

Investigation: Perpendicular Line Construction; through a Point on the Line

1. Draw a horizontal line and a point on that line.

Label the line l and the point A .



2. Take the compass and put the pointer on A . Open the compass so that it reaches out horizontally along the line. Draw two arcs that intersect the line on either side of the point.



3. Move the pointer to one of the arc intersections. Widen the compass a little and draw an arc above or below the line. Repeat this on the other side so that the two arc marks intersect.



4. Take your straightedge and draw a line from point A to the arc intersections above the line. This line is perpendicular to l and passes through A .

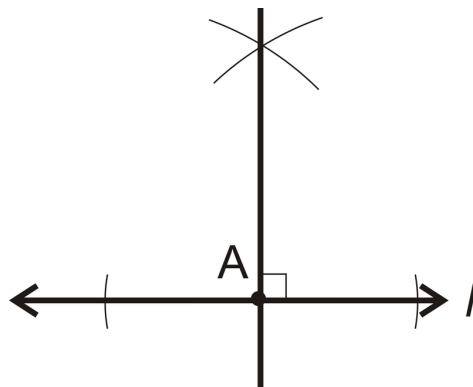

Notice that this is a different construction from a perpendicular bisector.

To see a demonstration of this construction, go to: <http://www.mathsisfun.com/geometry/construct-perponline.html>

Perpendicular Transversals

Recall that when two lines intersect, four angles are created. If the two lines are perpendicular, then all four angles are right angles, even though only one needs to be marked with the square. Therefore, all four angles are 90° .

When a parallel line is added, then there are eight angles formed. If $l \parallel m$ and $n \perp l$, is $n \perp m$? Let's prove it here.

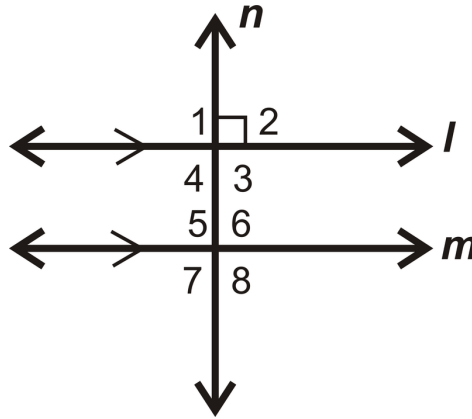

Given: $l \parallel m, l \perp n$

Prove: $n \perp m$

TABLE 3.1:

| <i>Statement</i> | <i>Reason</i> |
|--|-----------------------------------|
| 1. $l \parallel m, l \perp n$ | Given |
| 2. $\angle 1, \angle 2, \angle 3,$ and $\angle 4$ are right angles | Definition of perpendicular lines |
| 3. $m\angle 1 = 90^\circ$ | Definition of a right angle |
| 4. $m\angle 1 = m\angle 5$ | Corresponding Angles Postulate |
| 5. $m\angle 5 = 90^\circ$ | Transitive PoE |
| 6. $m\angle 6 = m\angle 7 = 90^\circ$ | Congruent Linear Pairs |
| 7. $m\angle 8 = 90^\circ$ | Vertical Angles Theorem |
| 8. $\angle 5, \angle 6, \angle 7,$ and $\angle 8$ are right angles | Definition of right angle |
| 9. $n \perp m$ | Definition of perpendicular lines |

Theorem #1: If two lines are parallel and a third line is perpendicular to one of the parallel lines, it is also perpendicular to the other parallel line.

Or, if $l \parallel m$ and $l \perp n$, then $n \perp m$.

Theorem #2: If two lines are perpendicular to the same line, they are parallel to each other.

Or, if $l \perp n$ and $n \perp m$, then $l \parallel m$. You will prove this theorem in the review questions.

From these two theorems, we can now assume that any angle formed by two parallel lines and a perpendicular transversal will always be 90° .

Example A

Find $m\angle CTA$.

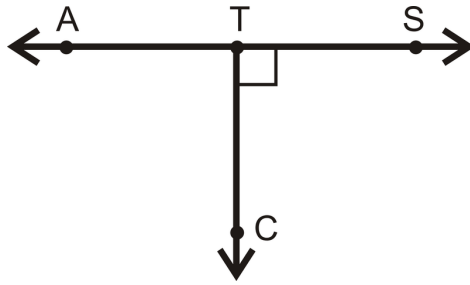

First, these two angles form a linear pair. Second, from the marking, we know that $\angle STC$ is a right angle. Therefore, $m\angle STC = 90^\circ$. So, $m\angle CTA$ is also 90° .

Example B

Determine the measure of $\angle 1$.

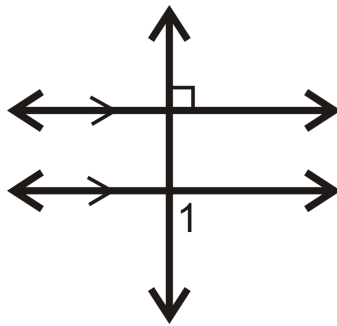

From Theorem #1, we know that the lower parallel line is also perpendicular to the transversal. Therefore, $m\angle 1 = 90^\circ$.

Example C

Find $m\angle 1$.

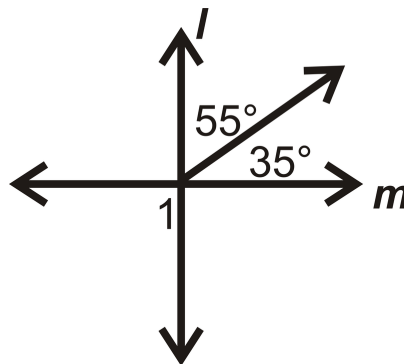

The two adjacent angles add up to 90° , so $l \perp m$. Therefore, $m\angle 1 = 90^\circ$.

Watch this video for help with the Examples above.



MEDIA

Click image to the left for more content.

CK-12 Foundation: Chapter3PerpendicularLinesB

Vocabulary

Two lines are *perpendicular* if they meet at a 90° , or *right*, angle.

Guided Practice

1. Is $l \perp m$? Explain why or why not.

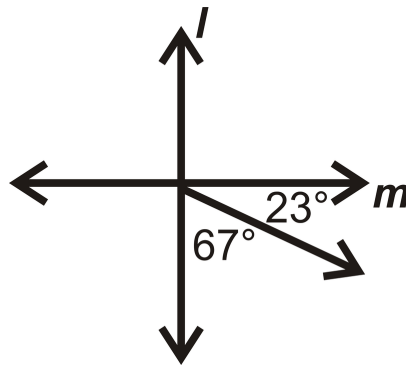

2. Find the value of x .

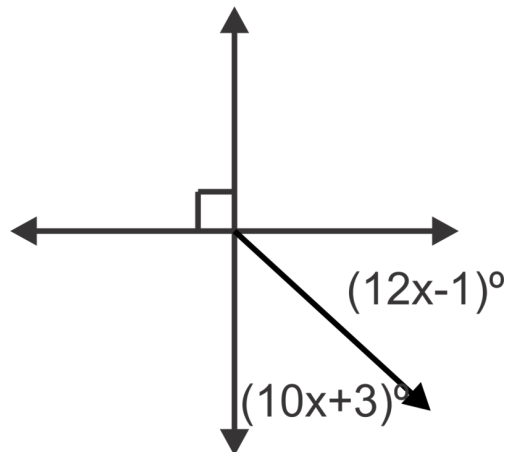

3. Find the value of x .

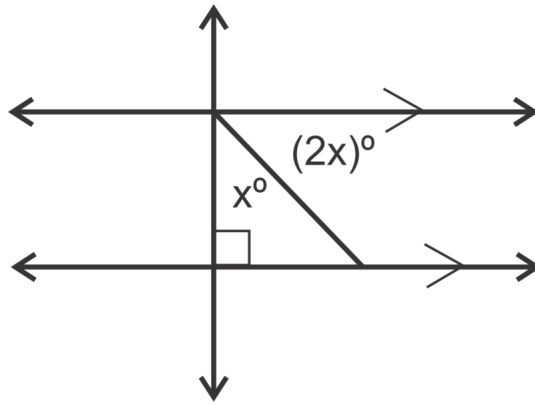
**Answers:**

1. If the two adjacent angles add up to 90° , then l and m are perpendicular.

$23^\circ + 67^\circ = 90^\circ$. Therefore, $l \perp m$.

2. The two angles together make a right angle. Set up an equation and solve for x .

$(12x - 1)^\circ + (10x + 3)^\circ = 90^\circ$ so $x = 4^\circ$.

3. The two angles together make a right angle. Set up an equation and solve for x .

$(2x)^\circ + x^\circ = 90^\circ$ so $x = 30^\circ$.

Practice

Find the measure of $\angle 1$ for each problem below.

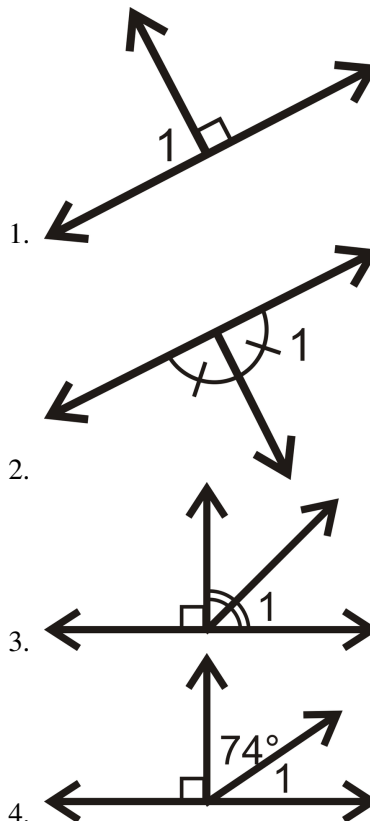

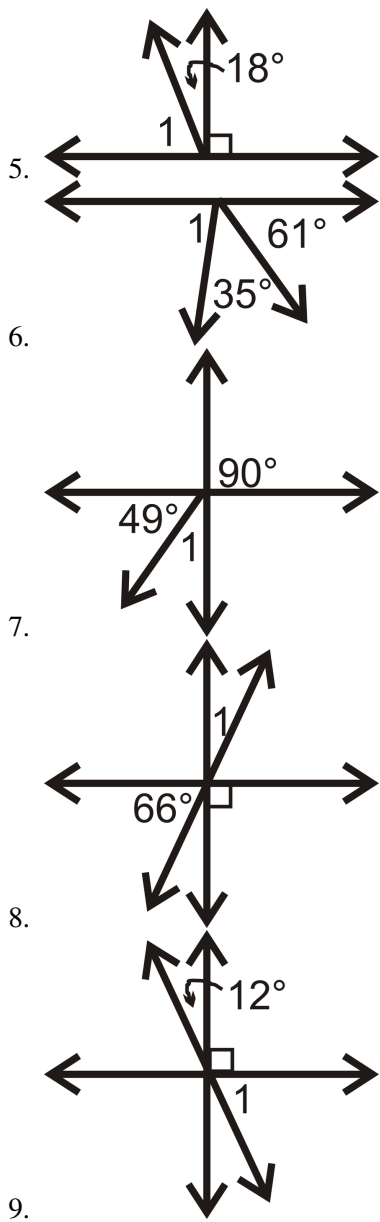

In questions 10-13, determine if $l \perp m$.

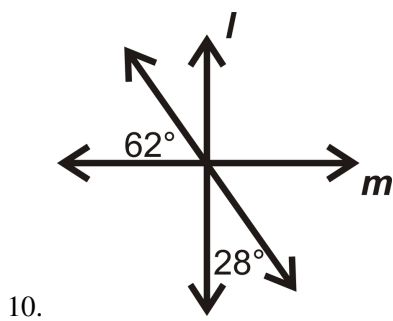

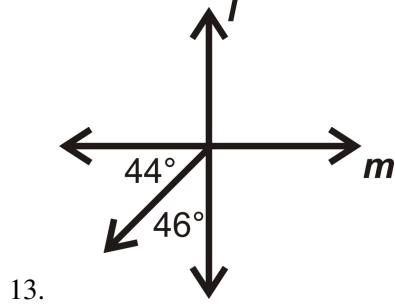
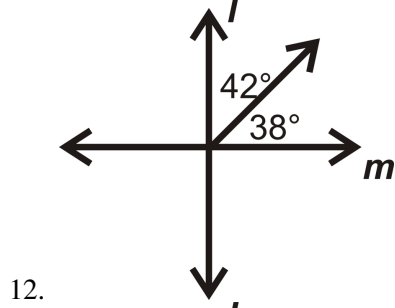
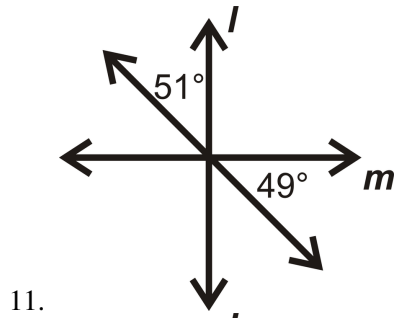

Find the value of x .

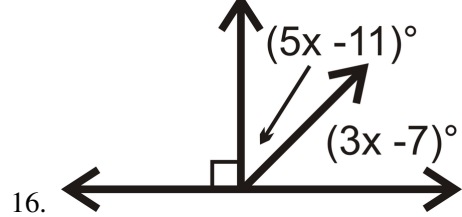
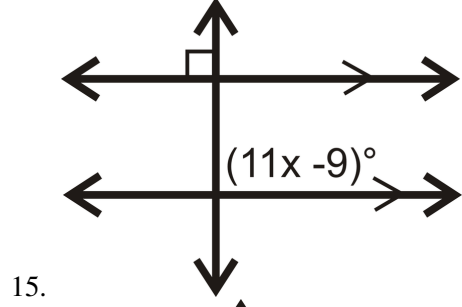
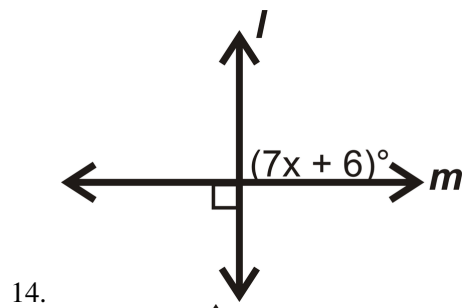

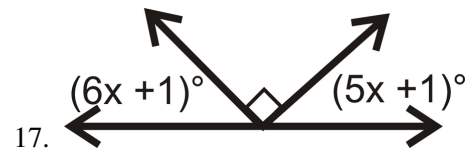

3.3 Corresponding Angles

Here you'll learn what corresponding angles are and their relationship with parallel lines.

What if you were presented with two angles that are in the same place with respect to the transversal but on different lines? How would you describe these angles and what could you conclude about their measures? After completing this Concept, you'll be able to answer these questions using your knowledge of corresponding angles.

Watch This



MEDIA

Click image to the left for more content.

CK-12 Foundation: Chapter3CorrespondingAnglesA

Watch the portions of this video dealing with corresponding angles.

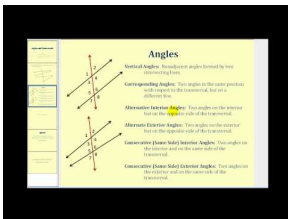

MEDIA

Click image to the left for more content.

James Sousa:Angles and Transversals

Watch this video beginning at the 4:50 mark.

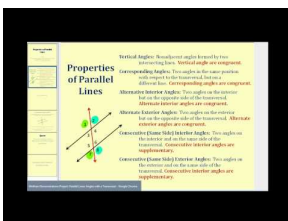

MEDIA

Click image to the left for more content.

James Sousa:Corresponding Angles Postulate

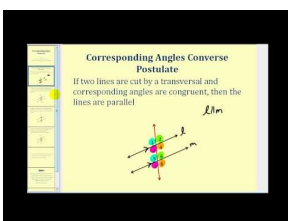

MEDIA

Click image to the left for more content.

James Sousa:Corresponding Angles Converse

Guidance

Corresponding Angles are two angles that are in the “same place” with respect to the transversal, but on different lines. Imagine sliding the four angles formed with line l down to line m . The angles which match up are corresponding. $\angle 2$ and $\angle 6$ are corresponding angles.

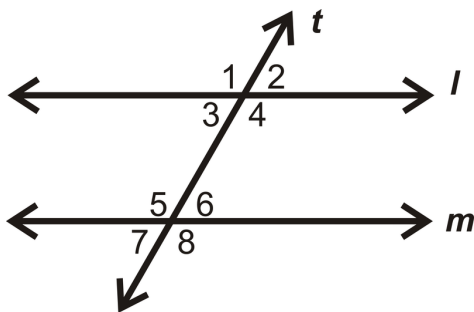

Corresponding Angles Postulate: If two parallel lines are cut by a transversal, then the corresponding angles are congruent.

If $l \parallel m$ and both are cut by t , then $\angle 1 \cong \angle 5$, $\angle 2 \cong \angle 6$, $\angle 3 \cong \angle 7$, and $\angle 4 \cong \angle 8$.

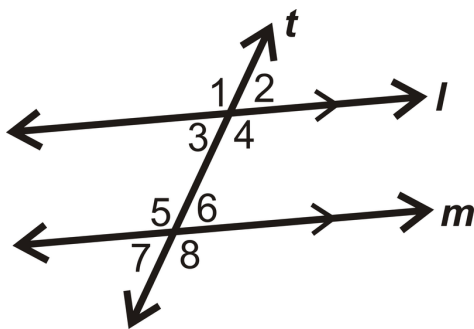

Converse of Corresponding Angles Postulate: If corresponding angles are congruent when two lines are cut by a transversal, then the lines are parallel.

Investigation: Corresponding Angles Exploration

You will need: paper, ruler, protractor

1. Place your ruler on the paper. On either side of the ruler, draw lines, 3 inches long. This is the easiest way to ensure that the lines are parallel.

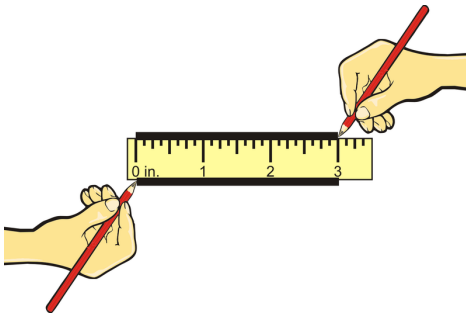

- Remove the ruler and draw a transversal. Label the eight angles as shown.

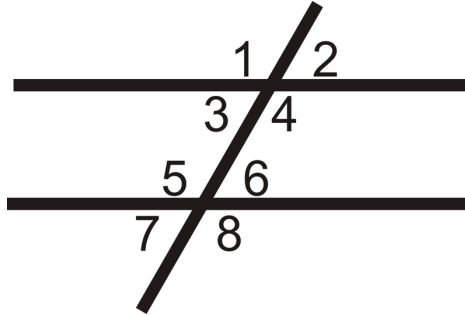

- Using your protractor, measure all of the angles. What do you notice?

In this investigation, you should see that $m\angle 1 = m\angle 4 = m\angle 5 = m\angle 8$ and $m\angle 2 = m\angle 3 = m\angle 6 = m\angle 7$. $\angle 1 \cong \angle 4$, $\angle 5 \cong \angle 8$ by the Vertical Angles Theorem. By the Corresponding Angles Postulate, we can say $\angle 1 \cong \angle 5$ and therefore $\angle 1 \cong \angle 8$ by the Transitive Property.

Investigation: Creating Parallel Lines using Corresponding Angles

- Draw two intersecting lines. Make sure they are not perpendicular. Label them l and m , and the point of intersection, A , as shown.

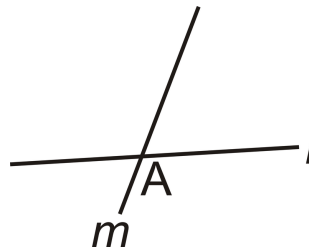

- Create a point, B , on line m , above A .

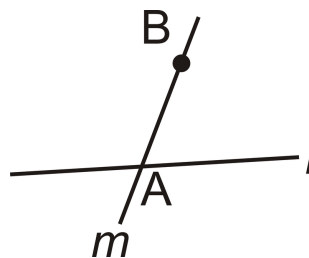

- Copy the acute angle at A (the angle to the right of m) at point B . See Investigation 2-2 in Chapter 2 for the directions on how to copy an angle.

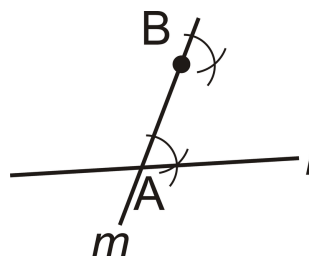

- Draw the line from the arc intersections to point B .

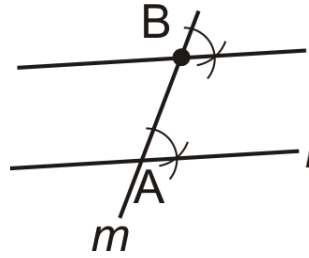

From this construction, we can see that the lines are parallel.

Example A

If $m\angle 8 = 110^\circ$ and $m\angle 4 = 110^\circ$, then what do we know about lines l and m ?

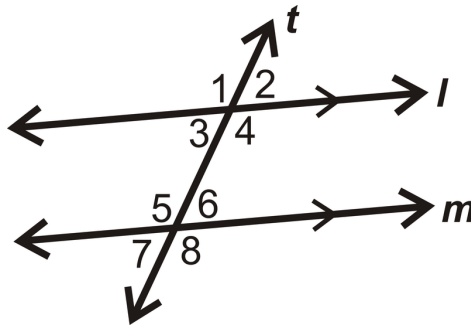

$\angle 8$ and $\angle 4$ are corresponding angles. Since $m\angle 8 = m\angle 4$, we can conclude that $l \parallel m$.

Example B

If $m\angle 2 = 76^\circ$, what is $m\angle 6$?

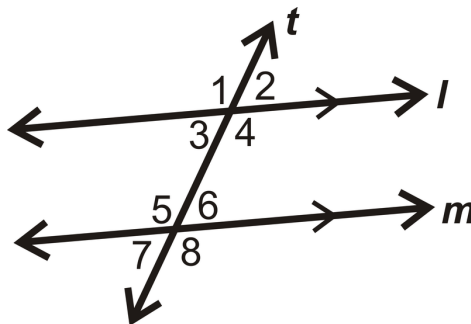

$\angle 2$ and $\angle 6$ are corresponding angles and $l \parallel m$, from the markings in the picture. By the Corresponding Angles Postulate the two angles are equal, so $m\angle 6 = 76^\circ$.

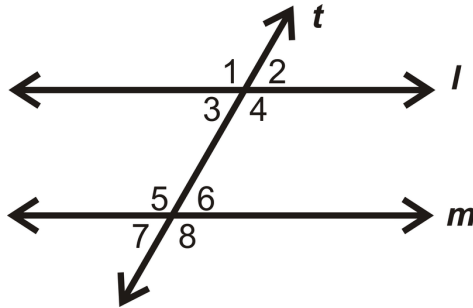
Example C

Using the picture above, list pairs of corresponding angles.

Corresponding Angles: $\angle 3$ and $\angle 7$, $\angle 1$ and $\angle 5$, $\angle 4$ and $\angle 8$

Watch this video for help with the Examples above.



MEDIA

Click image to the left for more content.

[CK-12 Foundation: Chapter3CorrespondingAnglesB](#)

Vocabulary

Corresponding Angles are two angles that are in the “same place” with respect to the transversal, but on different lines.

Guided Practice

Lines l and m are parallel:

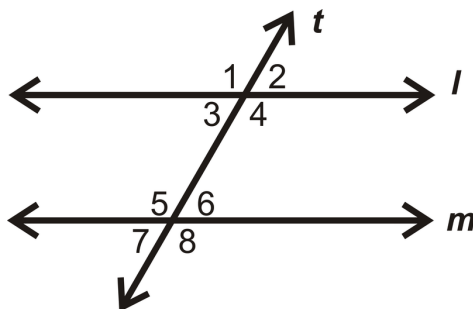

1. If $\angle 1 = 3x + 1$ and $\angle 5 = 4x - 3$, solve for x .
2. If $\angle 2 = 5x + 2$ and $\angle 6 = 3x + 10$, solve for x .
3. If $\angle 7 = 5x + 6$ and $\angle 3 = 8x - 10$, solve for x .

Answers:

1. Since they are corresponding angles and the lines are parallel, they must be congruent. Set the expressions equal to each other and solve for x . $3x + 1 = 4x - 3$ so $x = 4$.
2. Since they are corresponding angles and the lines are parallel, they must be congruent. Set the expressions equal to each other and solve for x . $5x + 2 = 3x + 10$ so $x = 4$.
3. Since they are corresponding angles and the lines are parallel, they must be congruent. Set the expressions equal to each other and solve for x . $5x + 5 = 8x - 10$ so $x = 5$.

Practice

1. Determine if the angle pair $\angle 4$ and $\angle 2$ is congruent, supplementary or neither:

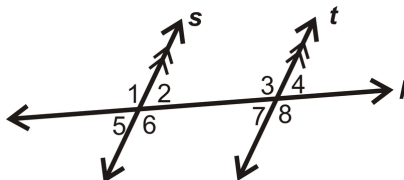

2. Give two examples of corresponding angles in the diagram:

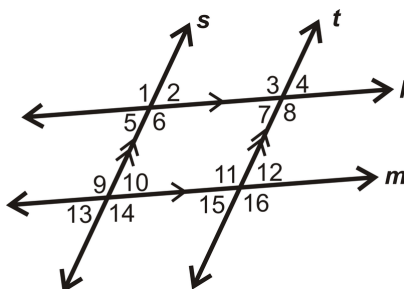

3. Find the value of x :

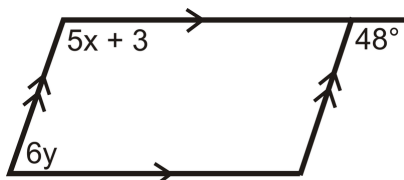

4. Are the lines parallel? Why or why not?

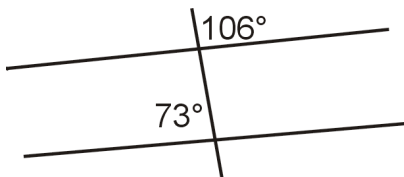

5. Are the lines parallel? Justify your answer.

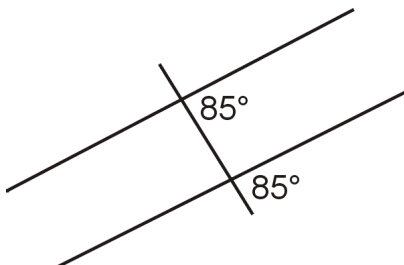

For 6-10, what does the value of x have to be to make the lines parallel?

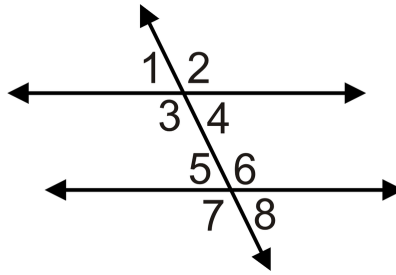

6. If $m\angle 1 = (6x - 5)^\circ$ and $m\angle 5 = (5x + 7)^\circ$.
7. If $m\angle 2 = (3x - 4)^\circ$ and $m\angle 6 = (4x - 10)^\circ$.
8. If $m\angle 3 = (7x - 5)^\circ$ and $m\angle 7 = (5x + 11)^\circ$.
9. If $m\angle 4 = (5x - 5)^\circ$ and $m\angle 8 = (3x + 15)^\circ$.
10. If $m\angle 2 = (2x + 4)^\circ$ and $m\angle 6 = (5x - 2)^\circ$.

For questions 11-15, use the picture below.

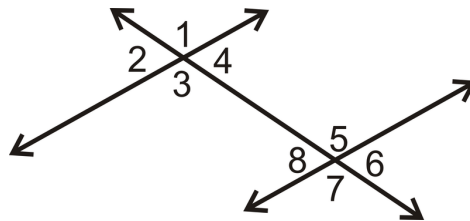

11. What is the corresponding angle to $\angle 4$?
12. What is the corresponding angle to $\angle 1$?
13. What is the corresponding angle to $\angle 2$?
14. What is the corresponding angle to $\angle 3$?
15. Are the two lines parallel? Explain.

3.4 Alternate Interior Angles

Here you'll learn what alternate interior angles are and their relationship with parallel lines.

What if you were presented with two angles that are on opposite sides of a transversal, but inside the lines? How would you describe these angles and what could you conclude about their measures? After completing this Concept, you'll be able to answer these questions using your knowledge of alternate interior angles.

Watch This



MEDIA

Click image to the left for more content.

CK-12 Foundation: Chapter3AlternateInteriorAnglesA

Watch the portions of this video dealing with alternate interior angles.

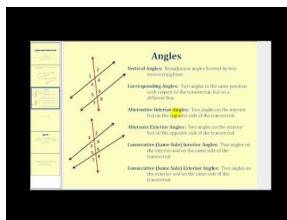

MEDIA

Click image to the left for more content.

James Sousa:Angles and Transversals

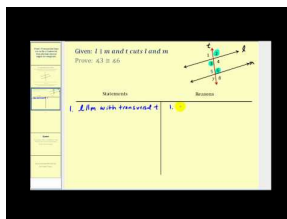

MEDIA

Click image to the left for more content.

James Sousa:Proof that Alternate Interior Angles Are Congruent

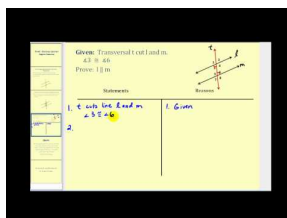

MEDIA

Click image to the left for more content.

James Sousa:Proof of Alternate Interior Angles Converse

Guidance

Alternate Interior Angles are two angles that are on the interior of l and m , but on opposite sides of the transversal. $\angle 3$ and $\angle 6$ are *alternate interior angles*.

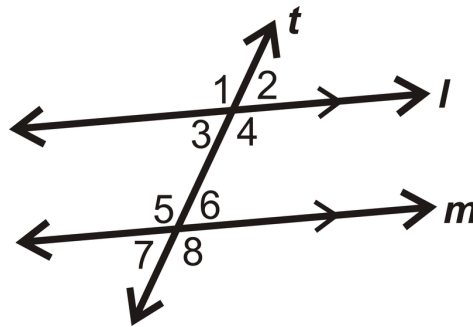

Alternate Interior Angles Theorem: If two parallel lines are cut by a transversal, then the alternate interior angles are congruent.

Proof of Alternate Interior Angles Theorem:

Given: $l \parallel m$

Prove: $\angle 3 \cong \angle 6$

TABLE 3.2:

| <i>Statement</i> | <i>Reason</i> |
|------------------------------|--------------------------------|
| 1. $l \parallel m$ | Given |
| 2. $\angle 3 \cong \angle 7$ | Corresponding Angles Postulate |
| 3. $\angle 7 \cong \angle 6$ | Vertical Angles Theorem |
| 4. $\angle 3 \cong \angle 6$ | Transitive PoC |

There are several ways we could have done this proof. For example, Step 2 could have been $\angle 2 \cong \angle 6$ for the same reason, followed by $\angle 2 \cong \angle 3$. We could have also proved that $\angle 4 \cong \angle 5$.

Converse of Alternate Interior Angles Theorem: If two lines are cut by a transversal and alternate interior angles are congruent, then the lines are parallel.

Example A

Find $m\angle 1$.

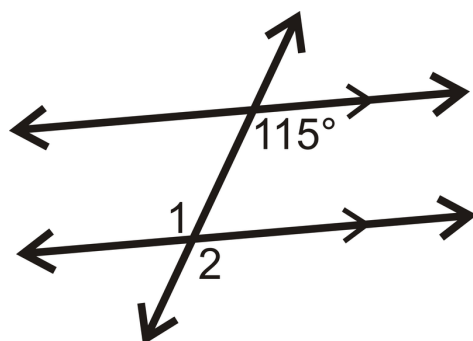

$m\angle 2 = 115^\circ$ because they are corresponding angles and the lines are parallel. $\angle 1$ and $\angle 2$ are vertical angles, so $m\angle 1 = 115^\circ$ also.

$\angle 1$ and the 115° angle are alternate interior angles.

Example B

Find the measure of the angle and x .

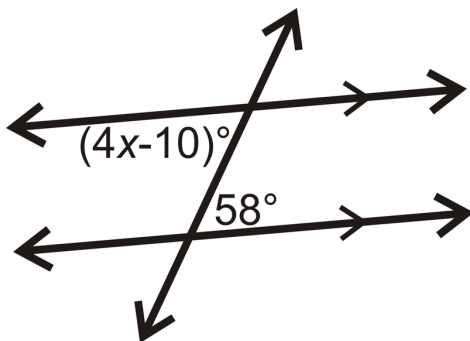

The two given angles are alternate interior angles so, they are equal. Set the two expressions equal to each other and solve for x .

$$(4x - 10)^\circ = 58^\circ$$

$$4x = 68^\circ$$

$$x = 17^\circ$$

Example C

Prove the Converse of the Alternate Interior Angles Theorem.

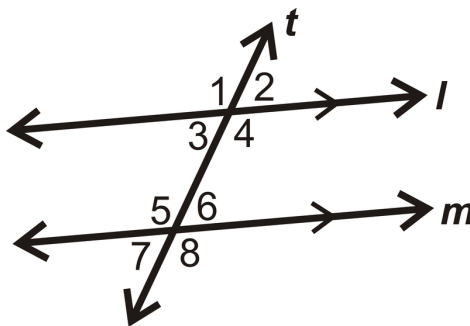

Given: l and m and transversal t

$\angle 3 \cong \angle 6$

Prove: $l \parallel m$

TABLE 3.3:

Statement

1. l and m and transversal t $\angle 3 \cong \angle 6$

Reason

Given

TABLE 3.3: (continued)

| <i>Statement</i> | <i>Reason</i> |
|------------------------------|--|
| 2. $\angle 3 \cong \angle 2$ | Vertical Angles Theorem |
| 3. $\angle 2 \cong \angle 6$ | Transitive PoC |
| 4. $l \parallel m$ | Converse of the Corresponding Angles Postulate |

Watch this video for help with the Examples above.



MEDIA

Click image to the left for more content.

CK-12 Foundation: Chapter3AlternateInteriorAnglesB

Vocabulary

Alternate Interior Angles are two angles that are on the interior of l and m , but on opposite sides of the transversal.

Guided Practice

1. Is $l \parallel m$?

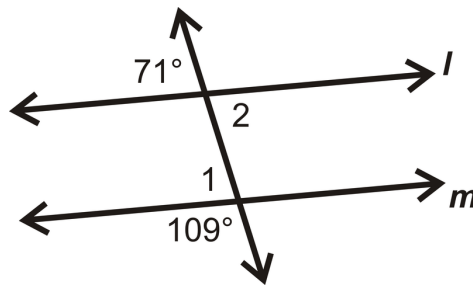

2. What does x have to be to make $a \parallel b$?

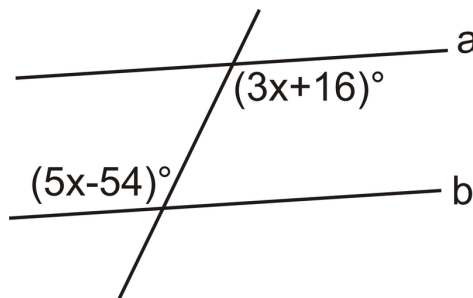

3. List the pairs of alternate interior angles:

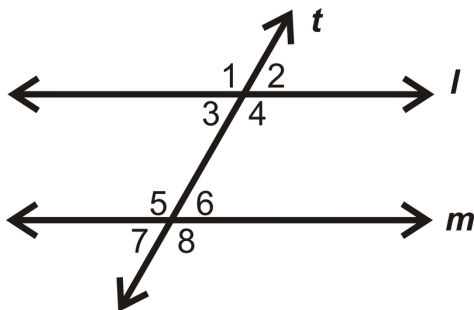

Answers:

1. First, find $m\angle 1$. We know its linear pair is 109° . By the Linear Pair Postulate, these two angles add up to 180° , so $m\angle 1 = 180^\circ - 109^\circ = 71^\circ$. This means that $l \parallel m$, by the Converse of the Corresponding Angles Postulate.
2. Because these are alternate interior angles, they must be equal for $a \parallel b$. Set the expressions equal to each other and solve.

$$\begin{aligned}
 3x + 16^\circ &= 5x - 54^\circ \\
 70^\circ &= 2x \\
 35^\circ &= x \quad \text{To make } a \parallel b, x = 35^\circ.
 \end{aligned}$$

3. Alternate Interior Angles: $\angle 4$ and $\angle 5$, $\angle 3$ and $\angle 6$.

Practice

1. Is the angle pair $\angle 6$ and $\angle 3$ congruent, supplementary or neither?

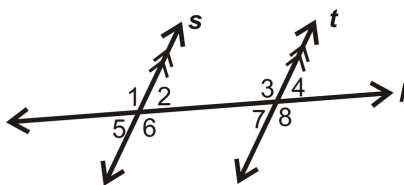

2. Give two examples of alternate interior angles in the diagram:

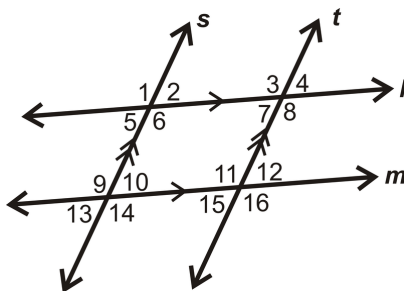

For 3-4, find the values of x .

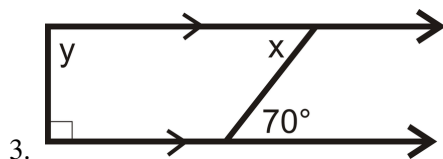

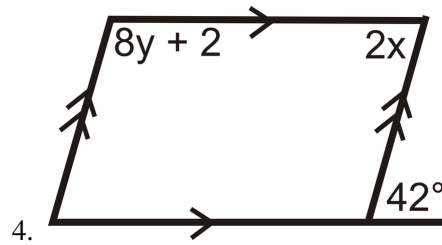

For question 5, use the picture below. Find the value of x .

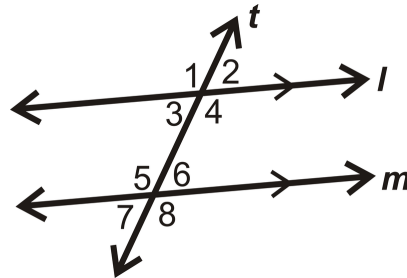

5. $m\angle 4 = (5x - 33)^\circ$, $m\angle 5 = (2x + 60)^\circ$

6. Are lines l and m parallel? If yes, how do you know?

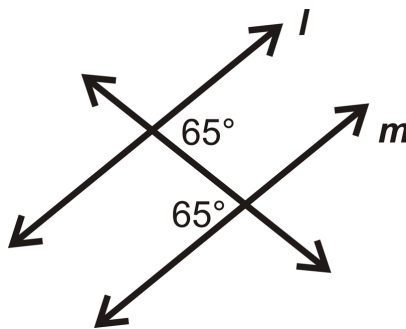

For 7-12, what does the value of x have to be to make the lines parallel?

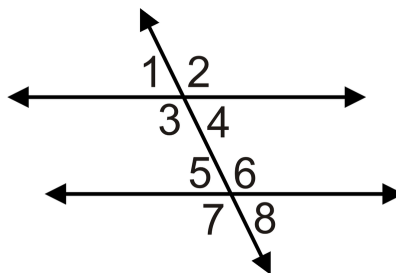

7. $m\angle 4 = (3x - 7)^\circ$ and $m\angle 5 = (5x - 21)^\circ$
8. $m\angle 3 = (2x - 1)^\circ$ and $m\angle 6 = (4x - 11)^\circ$
9. $m\angle 3 = (5x - 2)^\circ$ and $m\angle 6 = (3x)^\circ$
10. $m\angle 4 = (x - 7)^\circ$ and $m\angle 5 = (5x - 31)^\circ$
11. $m\angle 3 = (8x - 12)^\circ$ and $m\angle 6 = (7x)^\circ$
12. $m\angle 4 = (4x - 17)^\circ$ and $m\angle 5 = (5x - 29)^\circ$

For questions 13-15, use the picture below.

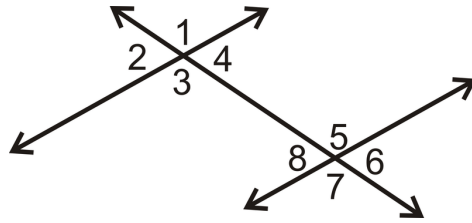

13. What is the alternate interior angle to $\angle 4$?
14. What is the alternate interior angle to $\angle 5$?
15. Are the two lines parallel? Explain.

3.5 Alternate Exterior Angles

Here you'll learn what alternate exterior angles are and their relationship with parallel lines.

What if you were presented with two angles that are on opposite sides of a transversal, but outside the lines? How would you describe these angles and what could you conclude about their measures? After completing this Concept, you'll be able to answer these questions using your knowledge of alternate exterior angles.

Watch This



MEDIA

Click image to the left for more content.

CK-12 Foundation: Chapter3AlternateExteriorAnglesA

Watch the portions of this video dealing with alternate exterior angles.

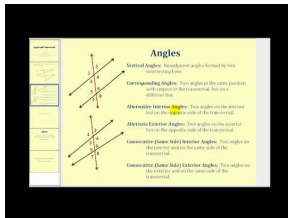

MEDIA

Click image to the left for more content.

James Sousa:Angles and Transversals

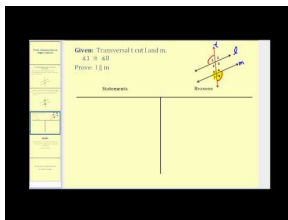

MEDIA

Click image to the left for more content.

James Sousa:Proof of Alternate Exterior Angles Converse

Guidance

Alternate Exterior Angles are two angles that are on the exterior of l and m , but on opposite sides of the transversal. $\angle 1$ and $\angle 8$ are *alternate exterior angles*.

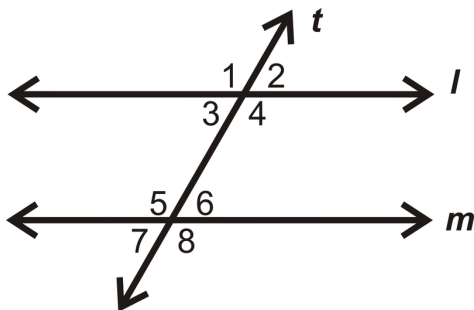

Alternate Exterior Angles Theorem: If two parallel lines are cut by a transversal, then the alternate exterior angles are congruent.

The proof of this theorem is very similar to that of the Alternate Interior Angles Theorem.

Converse of the Alternate Exterior Angles Theorem: If two lines are cut by a transversal and the alternate exterior angles are congruent, then the lines are parallel.

Example A

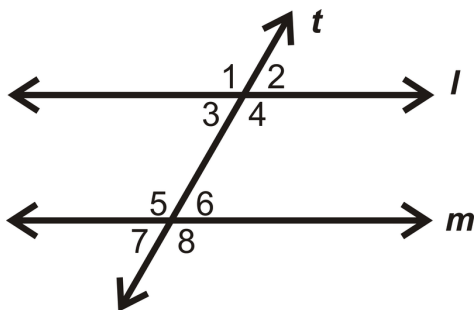

Using the picture above, list all the pairs of alternate exterior angles.

Alternate Exterior Angles: $\angle 2$ and $\angle 7$, $\angle 1$ and $\angle 8$.

Example B

Find $m\angle 1$ and $m\angle 3$.

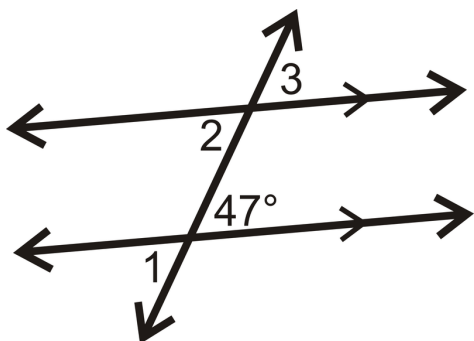

$m\angle 1 = 47^\circ$ because they are vertical angles. Because the lines are parallel, $m\angle 3 = 47^\circ$ by the Corresponding Angles Theorem. Therefore, $m\angle 2 = 47^\circ$.

$\angle 1$ and $\angle 3$ are alternate exterior angles.

Example C

The map below shows three roads in Julio's town.

Julio used a surveying tool to measure two angles at the intersections in this picture he drew (NOT to scale). **Julio wants to know if Franklin Way is parallel to Chavez Avenue.**

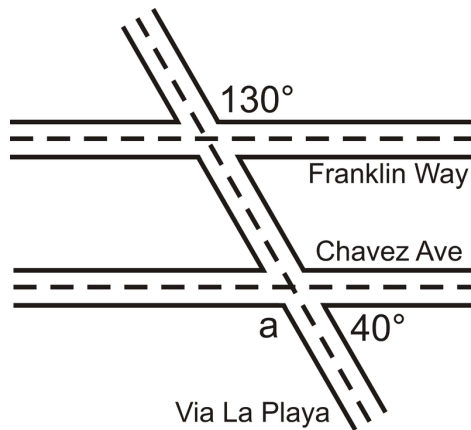

The labeled 130° angle and $\angle a$ are alternate exterior angles. If $m\angle a = 130^\circ$, then the lines are parallel. To find $m\angle a$, use the other labeled angle which is 40° , and its linear pair. Therefore, $\angle a + 40^\circ = 180^\circ$ and $\angle a = 140^\circ$. $140^\circ \neq 130^\circ$, so Franklin Way and Chavez Avenue are not parallel streets.

Watch this video for help with the Examples above.

**MEDIA**

Click image to the left for more content.

[CK-12 Foundation: Chapter3AlternateExteriorAnglesB](#)

Vocabulary

Alternate Exterior Angles are two angles that are on the exterior of l and m , but on opposite sides of the transversal.

Guided Practice

1. Find the measure of each angle and the value of y .

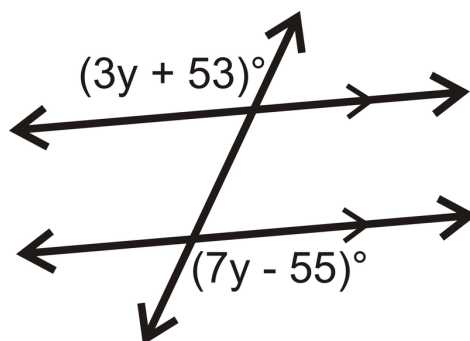

2. Give THREE examples of pairs of alternate exterior angles in the diagram below:

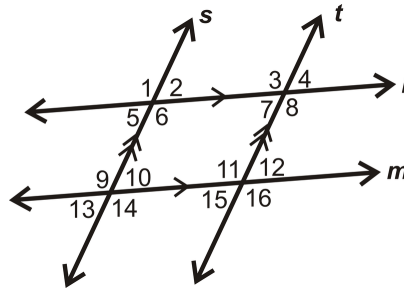

Answers:

1. The given angles are alternate exterior angles. Because the lines are parallel, we can set the expressions equal to each other to solve the problem.

$$\begin{aligned} (3y + 53)^\circ &= (7y - 55)^\circ \\ 108^\circ &= 4y \\ 27^\circ &= y \end{aligned}$$

If $y = 27^\circ$, then each angle is $3(27^\circ) + 53^\circ$, or 134° .

2. There are many examples of alternate exterior angles in the diagram. Here are some possible answers:

- $\angle 1$ and $\angle 14$
- $\angle 2$ and $\angle 13$
- $\angle 12$ and $\angle 13$

Practice

1. Find the value of x if $m\angle 1 = (4x + 35)^\circ$, $m\angle 8 = (7x - 40)^\circ$:

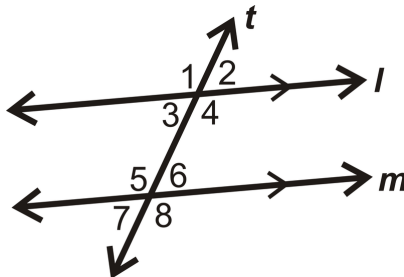

2. Are lines 1 and 2 parallel? Why or why not?

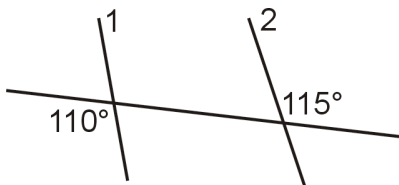

For 3-6, what does the value of x have to be to make the lines parallel?

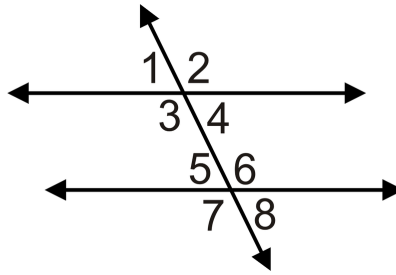

3. $m\angle 2 = (8x)^\circ$ and $m\angle 7 = (11x - 36)^\circ$
4. $m\angle 1 = (3x + 5)^\circ$ and $m\angle 8 = (4x - 3)^\circ$
5. $m\angle 2 = (6x - 4)^\circ$ and $m\angle 7 = (5x + 10)^\circ$
6. $m\angle 1 = (2x - 5)^\circ$ and $m\angle 8 = (x)^\circ$
7. $m\angle 2 = (3x + 50)^\circ$ and $m\angle 7 = (10x + 1)^\circ$
8. $m\angle 1 = (2x - 12)^\circ$ and $m\angle 8 = (x + 1)^\circ$

For 9-12, determine whether the statement is true or false.

9. Alternate exterior angles are always congruent.
10. If alternate exterior angles are congruent then lines are parallel.
11. Alternate exterior angles are on the interior of two lines.
12. Alternate exterior angles are on opposite sides of the transversal.

For questions 13-15, use the picture below.

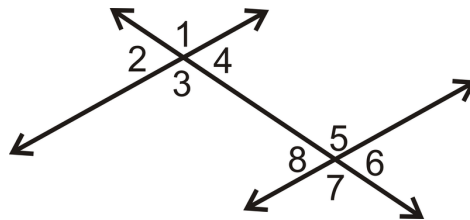

13. What is the alternate exterior angle with $\angle 2$?
14. What is the alternate exterior angle with $\angle 7$?
15. Are the two lines parallel? Explain.

3.6 Same Side Interior Angles

Here you'll learn what same side interior angles are and their relationship with parallel lines.

What if you were presented with two angles that are on the same side of a transversal, but inside the lines? How would you describe these angles and what could you conclude about their measures? After completing this Concept, you'll be able to answer these questions using your knowledge of same side interior angles.

Watch This



MEDIA

Click image to the left for more content.

CK-12 Foundation: Chapter3SameSideInteriorAnglesA

Watch the portions of this video dealing with same side interior angles.

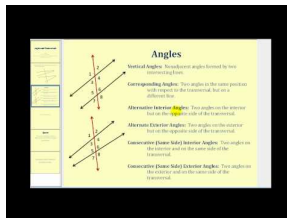

MEDIA

Click image to the left for more content.

James Sousa:Angles and Transversals

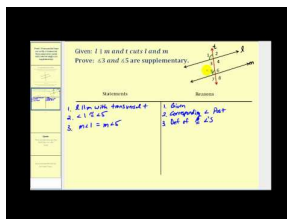

MEDIA

Click image to the left for more content.

James Sousa:Proof that Consecutive Interior Angles Are Supplementary

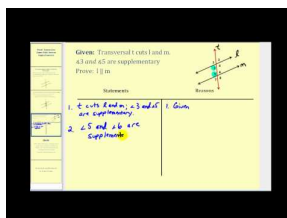

MEDIA

Click image to the left for more content.

James Sousa:Proof of Consecutive Interior Angles Converse

Guidance

Same Side Interior Angles are two angles that are on the same side of the transversal and on the interior of the two lines. $\angle 3$ and $\angle 5$ are *same side interior angles*.

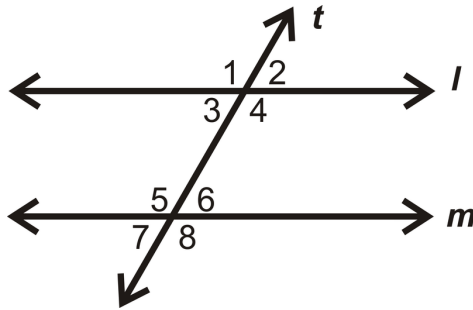

Same Side Interior Angles Theorem: If two parallel lines are cut by a transversal, then the same side interior angles are supplementary.

So, if $l \parallel m$ and both are cut by t , then $m\angle 3 + m\angle 5 = 180^\circ$ and $m\angle 4 + m\angle 6 = 180^\circ$.

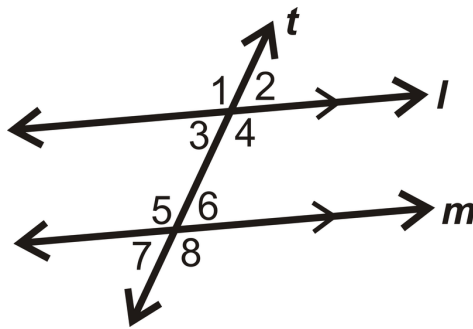

Converse of the Same Side Interior Angles Theorem: If two lines are cut by a transversal and the consecutive interior angles are supplementary, then the lines are parallel.

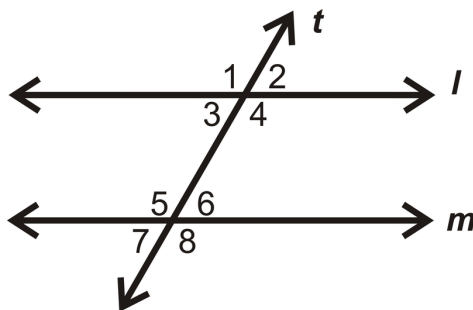
Example A

Using the picture above, list all the pairs of same side interior angles.

Same Side Interior Angles: $\angle 4$ and $\angle 6$, $\angle 5$ and $\angle 3$.

Example B

Find $m\angle 2$.

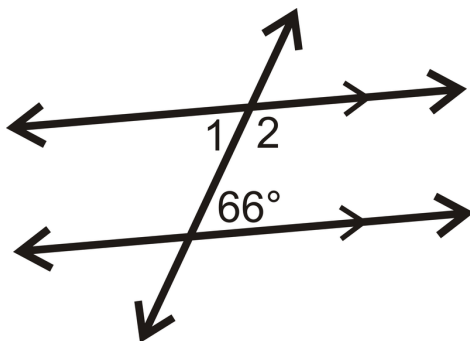

Here, $m\angle 1 = 66^\circ$ because they are alternate interior angles. $\angle 1$ and $\angle 2$ are a linear pair, so they are supplementary.

$$m\angle 1 + m\angle 2 = 180^\circ$$

$$66^\circ + m\angle 2 = 180^\circ$$

$$m\angle 2 = 114^\circ$$

This example shows why if two parallel lines are cut by a transversal, the same side interior angles are supplementary.

Example C

Find the measure of x .

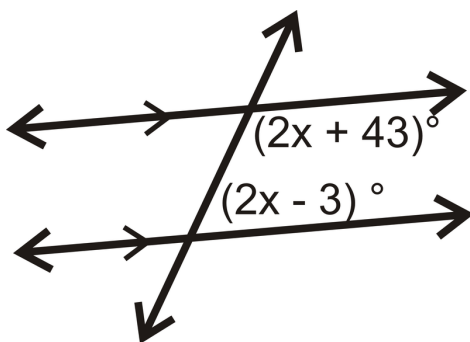

The given angles are same side interior angles. The lines are parallel, therefore the angles add up to 180° . Write an equation.

$$(2x + 43)^\circ + (2x - 3)^\circ = 180^\circ$$

$$(4x + 40)^\circ = 180^\circ$$

$$4x = 140^\circ$$

$$x = 35^\circ$$

Watch this video for help with the Examples above.



MEDIA

Click image to the left for more content.

CK-12 Foundation: Chapter3SameSideInteriorAnglesB

Vocabulary

Same Side Interior Angles are two angles that are on the same side of the transversal and on the interior of the two lines. Two angles are **supplementary** if they add to 180° .

Guided Practice

1. Is $l \parallel m$? How do you know?

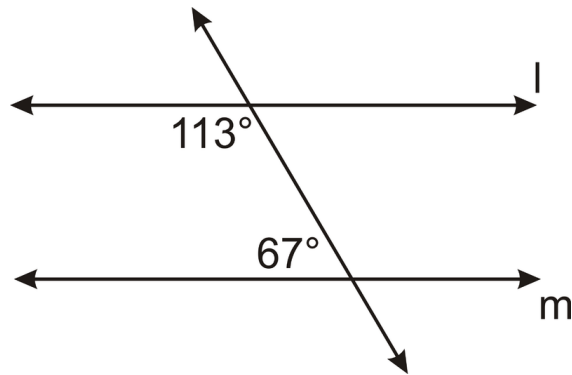

2. Find the value of x .

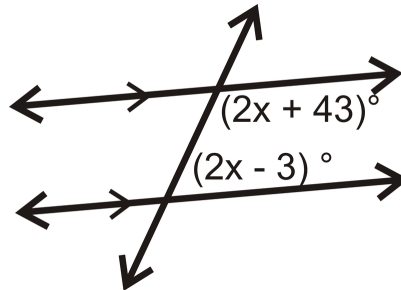

3. Find the value of x if $m\angle 3 = (3x + 12)^\circ$ and $m\angle 5 = (5x + 8)^\circ$.

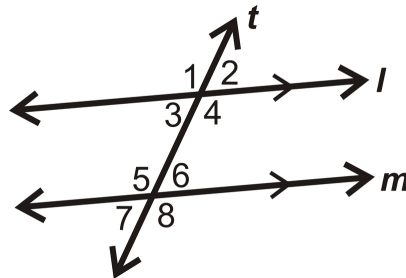

Answers:

1. These are Same Side Interior Angles. So, if they add up to 180° , then $l \parallel m$. $113^\circ + 67^\circ = 180^\circ$, therefore $l \parallel m$.
2. The given angles are same side interior angles. Because the lines are parallel, the angles add up to 180° .

$$\begin{aligned} (2x + 43)^\circ + (2x - 3)^\circ &= 180^\circ \\ (4x + 40)^\circ &= 180^\circ \\ 4x &= 140 \\ x &= 35 \end{aligned}$$

3. These are same side interior angles so set up an equation and solve for x . Remember that same side interior angles add up to 180° .

$$\begin{aligned} (3x + 12)^\circ + (5x + 8)^\circ &= 180^\circ \\ (8x + 20)^\circ &= 180^\circ \\ 8x &= 160 \\ x &= 20 \end{aligned}$$

Practice

For questions 1-2, determine if each angle pair below is congruent, supplementary or neither.

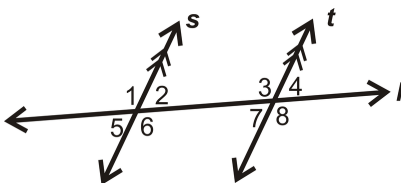

1. $\angle 5$ and $\angle 8$
2. $\angle 2$ and $\angle 3$
3. Are the lines below parallel? Justify your answer.

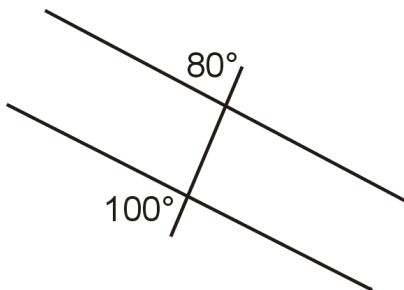

In 4-5, use the given information to determine which lines are parallel. If there are none, write none. Consider each question individually.

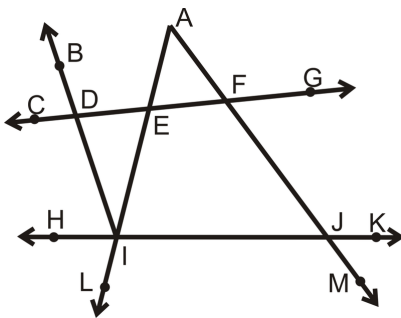

4. $\angle AFD$ and $\angle BDF$ are supplementary
5. $\angle DIJ$ and $\angle FJI$ are supplementary

For 6-11, what does the value of x have to be to make the lines parallel?

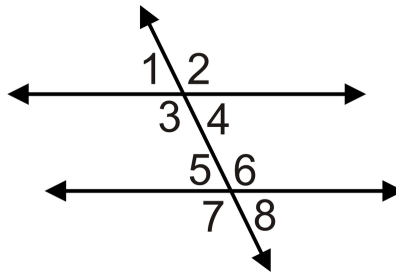

6. $m\angle 3 = (3x + 25)^\circ$ and $m\angle 5 = (4x - 55)^\circ$
7. $m\angle 4 = (2x + 15)^\circ$ and $m\angle 6 = (3x - 5)^\circ$
8. $m\angle 3 = (x + 17)^\circ$ and $m\angle 5 = (3x - 5)^\circ$
9. $m\angle 4 = (3x + 12)^\circ$ and $m\angle 6 = (4x - 1)^\circ$
10. $m\angle 3 = (2x + 14)^\circ$ and $m\angle 5 = (3x - 2)^\circ$
11. $m\angle 4 = (5x + 16)^\circ$ and $m\angle 6 = (7x - 4)^\circ$

For 12-13, determine whether the statement is true or false.

12. Same side interior angles are on the same side of the transversal.
13. Same side interior angles are congruent when lines are parallel.

For questions 14-15, use the picture below.

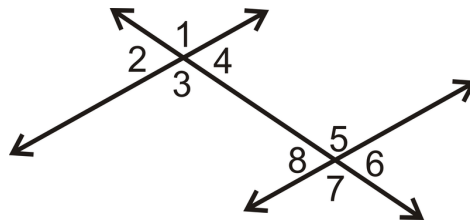

14. What is the same side interior angle with $\angle 3$?
15. Are the lines parallel? Explain.

3.7 Slope in the Coordinate Plane

Here you'll review how to calculate the slope of a line given two points on the line.

What if you wanted to compare the steepness of two roofs? After completing this Concept, you'll be able to determine the steepness of lines in the coordinate plane using what you learned in Algebra I about slope.

Watch This



MEDIA

Click image to the left for more content.

[CK-12 Foundation: Chapter3SlopeintheCoordinatePlaneA](#)

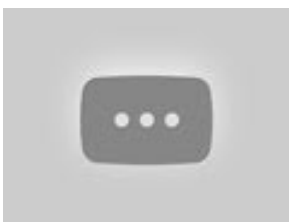

MEDIA

Click image to the left for more content.

[KhanAcademy: The Slope of aLine](#)

Guidance

Recall from Algebra I, the slope of the line between two points (x_1, y_1) and (x_2, y_2) is $m = \frac{(y_2 - y_1)}{(x_2 - x_1)}$.

Different Types of Slope:

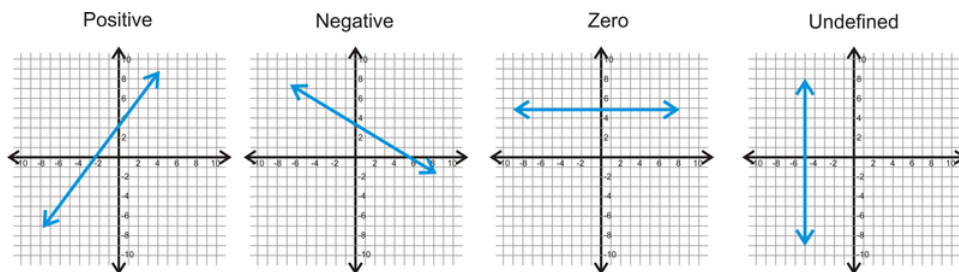

Example A

What is the slope of the line through $(2, 2)$ and $(4, 6)$?

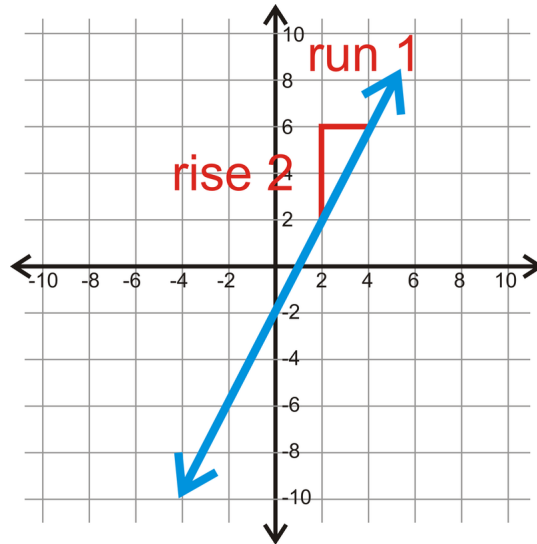

Use the slope formula to determine the slope. Use (2, 2) as (x_1, y_1) and (4, 6) as (x_2, y_2) .

$$m = \frac{6 - 2}{4 - 2} = \frac{4}{2} = 2$$

Therefore, the slope of this line is 2. This slope is positive.

Example B

Find the slope between (-8, 3) and (2, -2).

$$m = \frac{-2 - 3}{2 - (-8)} = \frac{-5}{10} = -\frac{1}{2}$$

This is a negative slope.

Example C

Find the slope between (-5, -1) and (3, -1).

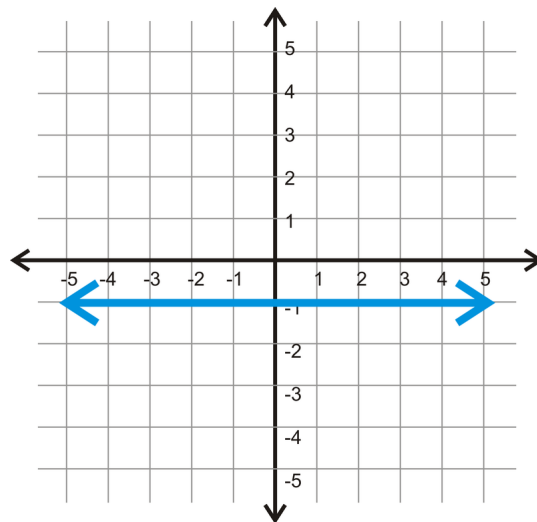

$$m = \frac{-1 - (-1)}{3 - (-5)} = \frac{0}{8} = 0$$

Therefore, the slope of this line is 0, which means that it is a horizontal line. Horizontal lines always pass through the y -axis. Notice that the y -coordinate for both points is -1 . In fact, the y -coordinate for *any* point on this line is -1 . This means that the horizontal line must cross $y = -1$.

Example D

What is the slope of the line through $(3, 2)$ and $(3, 6)$?

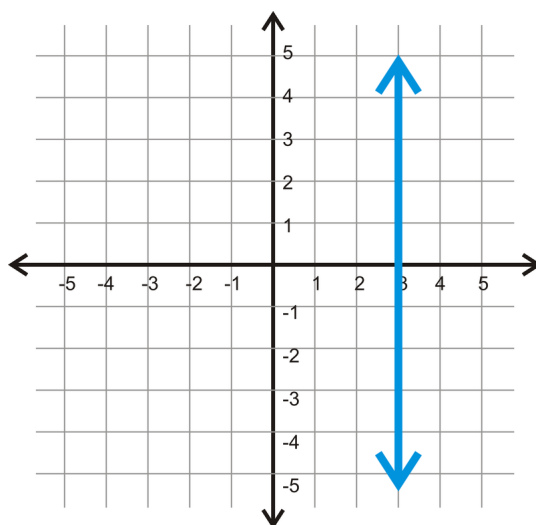

$$m = \frac{6 - 2}{3 - 3} = \frac{4}{0} = \text{undefined}$$

Therefore, the slope of this line is undefined, which means that it is a *vertical* line. Vertical lines always pass through the x -axis. Notice that the x -coordinate for both points is 3 . In fact, the x -coordinate for *any* point on this line is 3 . This means that the vertical line must cross $x = 3$.

Watch this video for help with the Examples above.



MEDIA

Click image to the left for more content.

[CK-12 Foundation: Chapter3SlopeintheCoordinatePlaneB](#)

Vocabulary

Slope is the steepness of a line. Two points (x_1, y_1) and (x_2, y_2) have a slope of $m = \frac{(y_2 - y_1)}{(x_2 - x_1)}$.

Guided Practice

Find the slope between the two given points:

1. (3, -4) and (3, 7)
2. (6, 1) and (4, 2)
3. (5, 7) and (11, 7)

Answers:

1. These two points create a vertical line, so the slope is undefined.
2. The slope is $\frac{2-1}{4-6} = -\frac{1}{2}$.
3. These two points create a horizontal line, so the slope is zero.

Practice

Find the slope between the two given points.

1. (4, -1) and (-2, -3)
2. (-9, 5) and (-6, 2)
3. (7, 2) and (-7, -2)
4. (-6, 0) and (-1, -10)
5. (1, -2) and (3, 6)
6. (-4, 5) and (-4, -3)
7. (-2, 3) and (-2, -3)
8. (4, 1) and (7, 1)
9. (22, 37) and (-34, 56)
10. (13, 12) and (-23, 14)
11. (-4, 2) and (-16, 12)

For 12-15, determine if the statement is true or false.

12. If you know the slope of a line you will know whether it is pointing up or down from left to right.
13. Vertical lines have a slope of zero.
14. Horizontal lines have a slope of zero.
15. The larger the absolute value of the slope, the less steep the line.

3.8 Parallel Lines in the Coordinate Plane

Here you'll learn properties of parallel lines in the coordinate plane, and how slope can help you to determine whether or not two lines are parallel.

What if you wanted to figure out if two lines in a shape were truly parallel? How could you do this? After completing this Concept, you'll be able to use slope to help you to determine whether or not lines are parallel.

Watch This



MEDIA

Click image to the left for more content.

[CK-12 Foundation: Chapter3ParallelLinesintheCoordinatePlaneA](#)

Watch the portion of this video that deals with Parallel Lines

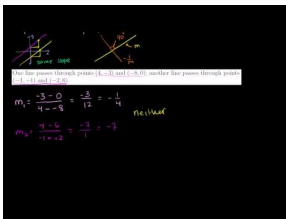

MEDIA

Click image to the left for more content.

[KhanAcademy: Equations of Parallel and Perpendicular Lines](#)

Guidance

Recall that parallel lines are two lines that never intersect. In the coordinate plane, that would look like this:

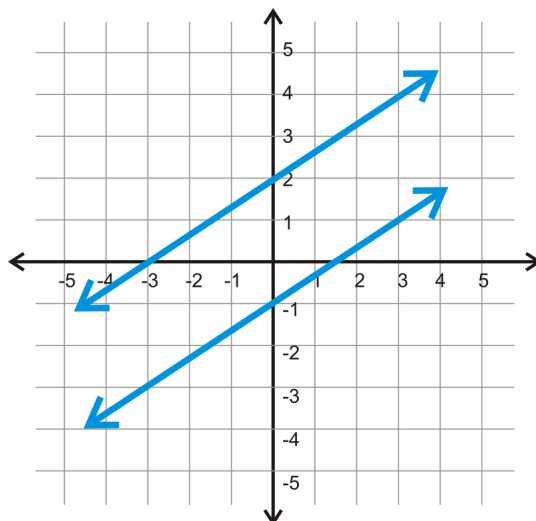

If we take a closer look at these two lines, we see that the slopes of both are $\frac{2}{3}$.

This can be generalized to any pair of parallel lines in the coordinate plane. **Parallel lines have the same slope.**

Example A

Find the equation of the line that is parallel to $y = -\frac{1}{3}x + 4$ and passes through $(9, -5)$.

Recall that the equation of a line in this form is called the slope-intercept form and is written as $y = mx + b$ where m is the slope and b is the y -intercept. Here, x and y represent any coordinate pair, (x, y) on the line.

We know that parallel lines have the same slope, so the line we are trying to find also has $m = -\frac{1}{3}$. Now, we need to find the y -intercept. 4 is the y -intercept of the given line, *not our new line*. We need to plug in 9 for x and -5 for y (this is our given coordinate pair that needs to be on the line) to solve for the *new* y -intercept (b).

$$-5 = -\frac{1}{3}(9) + b$$

$$-5 = -3 + b \quad \text{Therefore, the equation of line is } y = -\frac{1}{3}x - 2.$$

$$-2 = b$$

Example B

Which of the following pairs of lines are parallel?

- $y = -2x + 3$ and $y = \frac{1}{2}x + 3$
- $y = 4x - 2$ and $y = 4x + 5$
- $y = -x + 5$ and $y = x + 1$

Because all the equations are in $y = mx + b$ form, you can easily compare the slopes by looking at the values of m . To be parallel, the lines must have equal values for m . The **second** pair of lines is the only one that is parallel.

Example C

Find the equation of the line that is parallel to the line through the point marked with a blue dot.

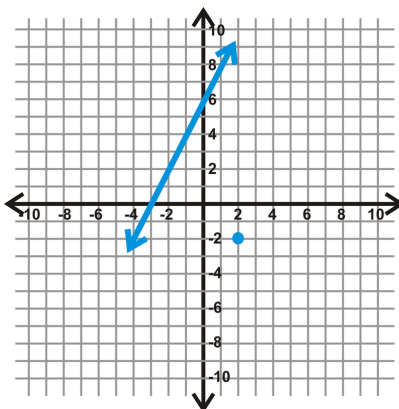

First, notice that the equation of the line is $y = 2x + 6$ and the point is $(2, -2)$. The parallel would have the same slope and pass through $(2, -2)$.

$$\begin{aligned} y &= 2x + b \\ -2 &= 2(2) + b \\ -2 &= 4 + b \\ -6 &= b \end{aligned}$$

The equation of the parallel line is $y = 2x - 6$.

Watch this video for help with the Examples above.

**MEDIA**

Click image to the left for more content.

[CK-12 Foundation: Chapter3ParallelLinesintheCoordinatePlaneB](#)

Vocabulary

Two lines in the coordinate plane with the same slope are *parallel* and never intersect. *Slope* measures the steepness of a line.

Guided Practice

1. Which of the following pairs of lines are parallel?

- $y = -3x + 1$ and $y = 3x - 1$
- $2x - 3y = 6$ and $3x + 2y = 6$

- $5x + 2y = -4$ and $5x + 2y = 8$
- $x - 3y = -3$ and $x + 3y = 9$
- $x + y = 6$ and $4x + 4y = -16$

2. Find the equation of the line that is parallel to $y = \frac{1}{4}x + 3$ and passes through $(8, -7)$.
3. Find the equation of the lines below and determine if they are parallel.

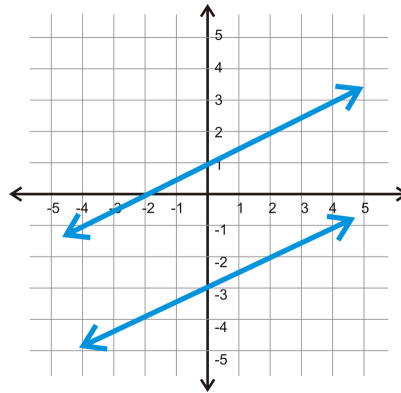
**Answers:**

1. First change all equations into $y = mx + b$ form so that you can easily compare the slopes by looking at the values of m . The *third* and *fifth* pair of lines are the only ones that are parallel.
2. We know that parallel lines have the same slope, so the line will have a slope of $\frac{1}{4}$. Now, we need to find the y -intercept. Plug in 8 for x and -7 for y to solve for the *new* y -intercept (b).

$$\begin{aligned} -7 &= \frac{1}{4}(8) + b \\ -7 &= 2 + b \\ -9 &= b \end{aligned}$$

The equation of the parallel line is $y = \frac{1}{4}x - 9$.

3. The top line has a y -intercept of 1. From there, use “rise over run” to find the slope. From the y -intercept, if you go up 1 and over 2, you hit the line again, $m = \frac{1}{2}$. The equation is $y = \frac{1}{2}x + 1$.

For the second line, the y -intercept is -3. The “rise” is 1 and the “run” is 2 making the slope $\frac{1}{2}$. The equation of this line is $y = \frac{1}{2}x - 3$.

The lines are **parallel** because they have the same slope.

Practice

Determine the equation of the line that is **parallel** to the given line, through the given point.

1. $y = -5x + 1$; $(-2, 3)$
2. $y = \frac{2}{3}x - 2$; $(9, 1)$
3. $x - 4y = 12$; $(-16, -2)$

4. $3x + 2y = 10$; $(8, -11)$
5. $2x - y = 15$; $(3, 7)$
6. $y = x - 5$; $(9, -1)$
7. $y = 3x - 4$; $(2, -3)$

Then, determine if the two lines are parallel or not.

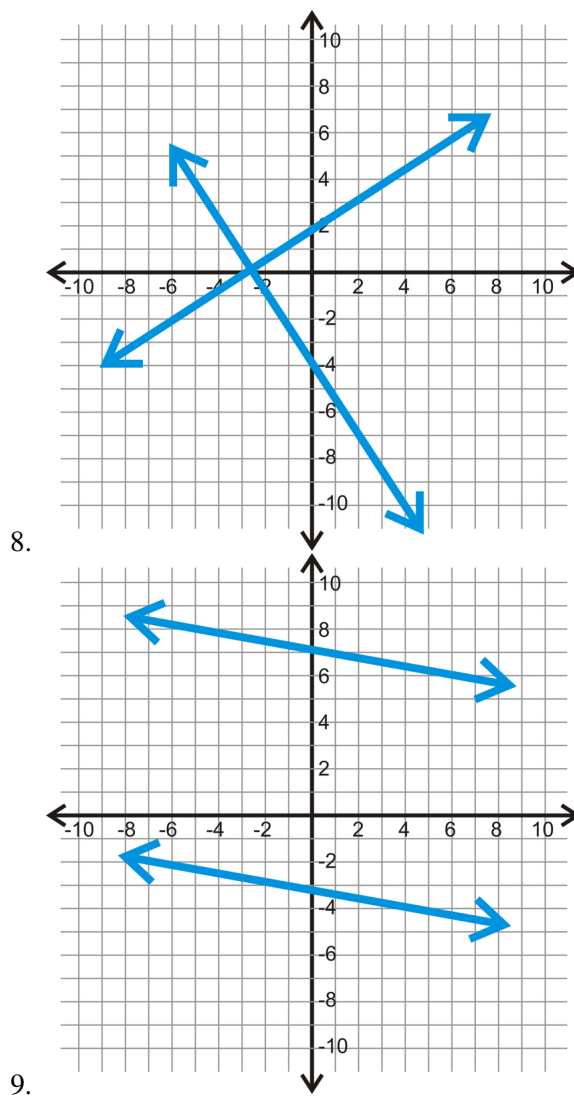

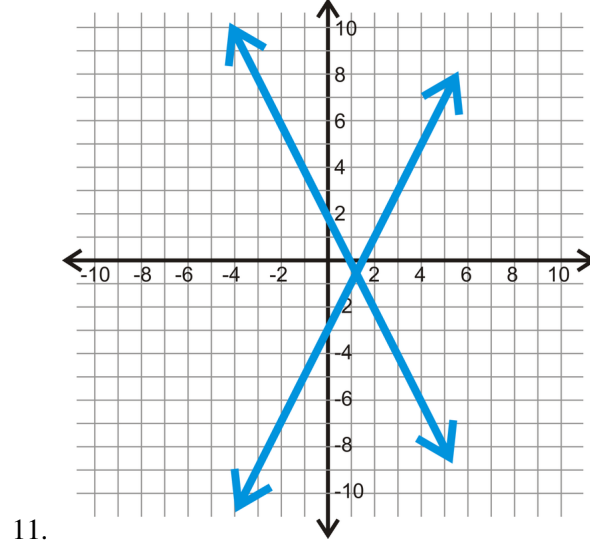
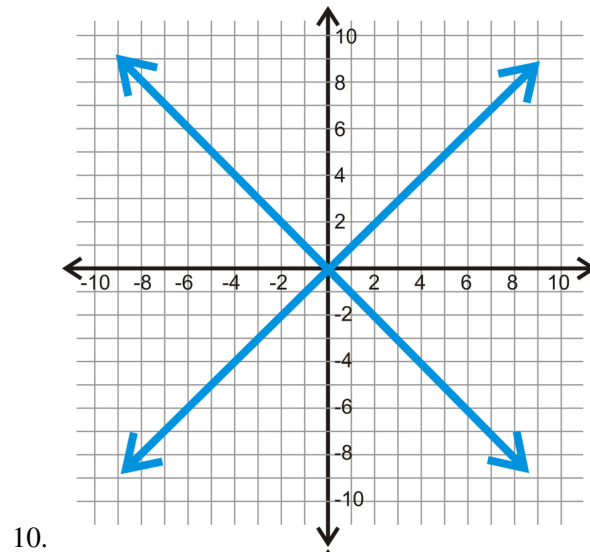

For the line and point below, find a parallel line, through the given point.

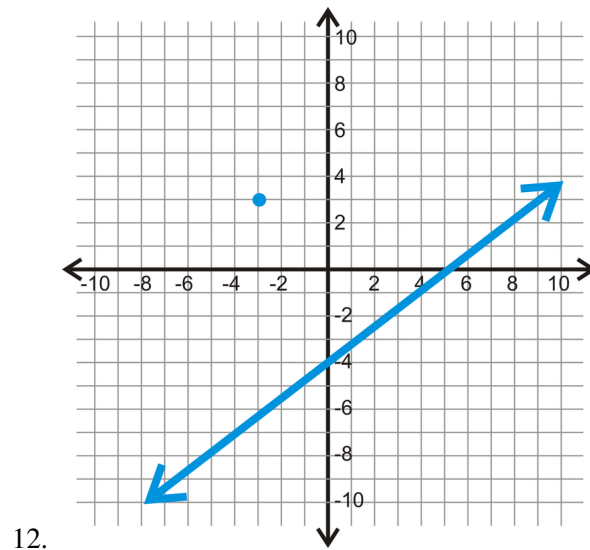

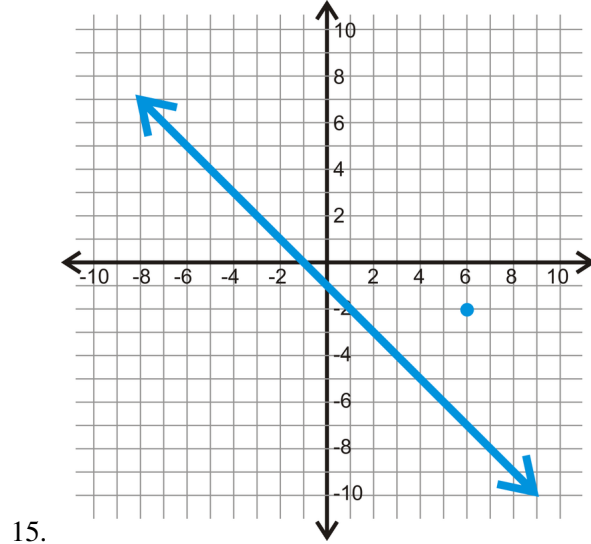
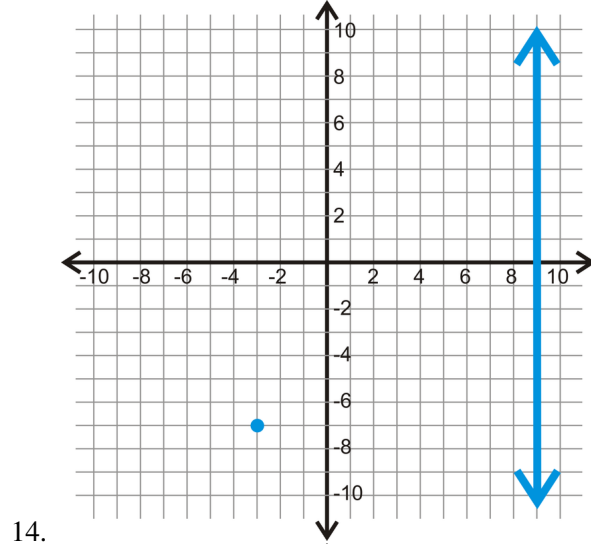
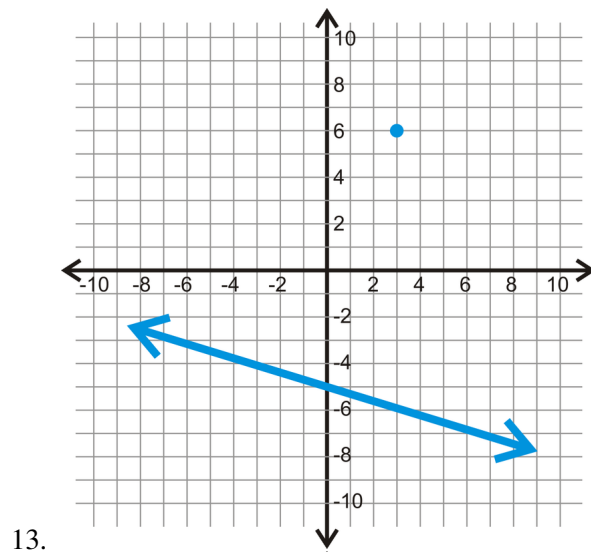

3.9 Perpendicular Lines in the Coordinate Plane

Here you'll learn properties of perpendicular lines in the coordinate plane, and how slope can help you to determine whether or not two lines are perpendicular.

What if you wanted to figure out if two lines in a shape met at right angles? How could you do this? After completing this Concept, you'll be able to use slope to help you determine whether or not lines are perpendicular.

Watch This



MEDIA

Click image to the left for more content.

[CK-12 Foundation: Chapter3PerpendicularLinesintheCoordinatePlaneA](#)

Watch the portion of this video that deals with Perpendicular Lines

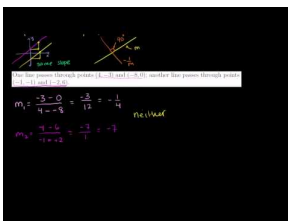

MEDIA

Click image to the left for more content.

[KhanAcademy: Equations of Parallel and Perpendicular Lines](#)

Guidance

Recall that the definition of **perpendicular** is two lines that intersect at a 90° , or right, angle. In the coordinate plane, that would look like this:

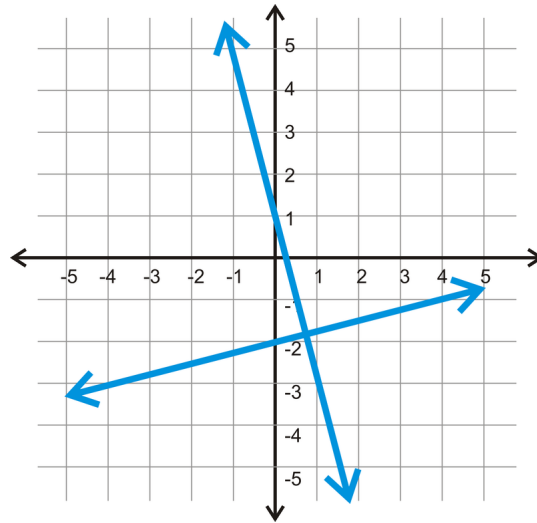

If we take a closer look at these two lines, we see that the slope of one is -4 and the other is $\frac{1}{4}$. This can be generalized to any pair of perpendicular lines in the coordinate plane. ***The slopes of perpendicular lines are opposite signs and reciprocals of each other.***

Example A

Find the slope of the perpendicular lines to the lines below.

a) $y = 2x + 3$

b) $y = -\frac{2}{3}x - 5$

c) $y = x + 2$

We are only concerned with the slope for each of these.

a) $m = 2$, so m_{\perp} is the reciprocal and negative, $m_{\perp} = -\frac{1}{2}$.

b) $m = -\frac{2}{3}$, take the reciprocal and make the slope positive, $m_{\perp} = \frac{3}{2}$.

c) Because there is no number in front of x , the slope is 1. The reciprocal of 1 is 1, so the only thing to do is make it negative, $m_{\perp} = -1$.

Example B

Find the equation of the line that is perpendicular to $y = -\frac{1}{3}x + 4$ and passes through $(9, -5)$.

First, the slope is the reciprocal and opposite sign of $-\frac{1}{3}$. So, $m = 3$. Now, we need to find the y -intercept. 4 is the y -intercept of the given line, *not our new line*. We need to plug in 9 for x and -5 for y to solve for the *new* y -intercept (b).

$$\begin{aligned} -5 &= 3(9) + b \\ -5 &= 27 + b && \text{Therefore, the equation of line is } y = 3x - 32. \\ -32 &= b \end{aligned}$$

Example C

Graph $3x - 4y = 8$ and $4x + 3y = 15$. Determine if they are perpendicular.

First, we have to change each equation into slope-intercept form. In other words, we need to solve each equation for y .

$$3x - 4y = 8$$

$$-4y = -3x + 8$$

$$y = \frac{3}{4}x - 2$$

$$4x + 3y = 15$$

$$3y = -4x + 15$$

$$y = -\frac{4}{3}x + 5$$

Now that the lines are in slope-intercept form (also called y -intercept form), we can tell they are perpendicular because their slopes are opposite reciprocals.

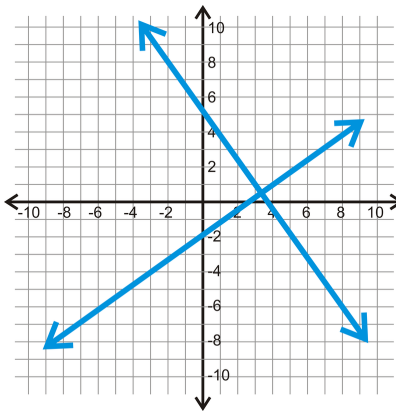

Watch this video for help with the Examples above.



MEDIA

Click image to the left for more content.

[CK-12 Foundation: Chapter3PerpendicularLinesintheCordinatePlaneB](#)

Vocabulary

Two lines in the coordinate plane with slopes that are opposite signs and reciprocals of each other are **perpendicular** and intersect at a 90° , or right, angle. **Slope** measures the steepness of a line.

Guided Practice

1. Determine which of the following pairs of lines are perpendicular.

- $y = -2x + 3$ and $y = \frac{1}{2}x + 3$

- $y = 4x - 2$ and $y = 4x + 5$

- $y = -x + 5$ and $y = x + 1$

- Find the equation of the line that is perpendicular to the line $y = 2x + 7$ and goes through the point $(2, -2)$.
- Give an example of a line that is perpendicular to the line $y = \frac{2}{3}x - 4$.

Answers:

- Two lines are perpendicular if their slopes are opposite reciprocals. The only pairs of lines this is true for is the *first* pair, because -2 and $\frac{1}{2}$ are opposites and reciprocals.
- The perpendicular line goes through $(2, -2)$, but the slope is $-\frac{1}{2}$ because we need to take the opposite reciprocal of 2.

$$\begin{aligned}y &= -\frac{1}{2}x + b \\-2 &= -\frac{1}{2}(2) + b \\-2 &= -1 + b \\-1 &= b\end{aligned}$$

The equation is $y = -\frac{1}{2}x - 1$.

- Any line perpendicular to $y = \frac{2}{3}x - 4$ will have a slope of $-\frac{3}{2}$. Any equation of the form $y = -\frac{3}{2}x + b$ will work.

Practice

- Determine which of the following pairs of lines are perpendicular.

- $y = -3x + 1$ and $y = 3x - 1$
- $2x - 3y = 6$ and $3x + 2y = 6$
- $5x + 2y = -4$ and $5x + 2y = 8$
- $x - 3y = -3$ and $x + 3y = 9$
- $x + y = 6$ and $4x + 4y = -16$

Determine the equation of the line that is **perpendicular** to the given line, through the given point.

- $y = x - 1$; $(-6, 2)$
- $y = 3x + 4$; $(9, -7)$
- $5x - 2y = 6$; $(5, 5)$
- $y = 4$; $(-1, 3)$
- $x = -3$; $(1, 8)$
- $x - 3y = 11$; $(0, 13)$

Determine if each pair of lines is perpendicular or not.

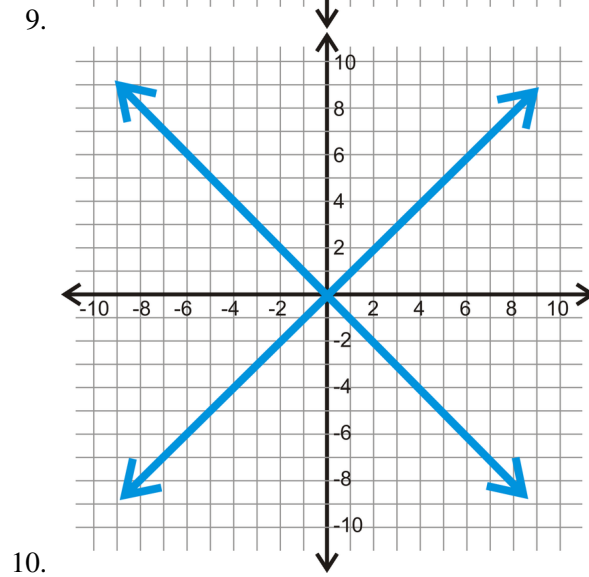
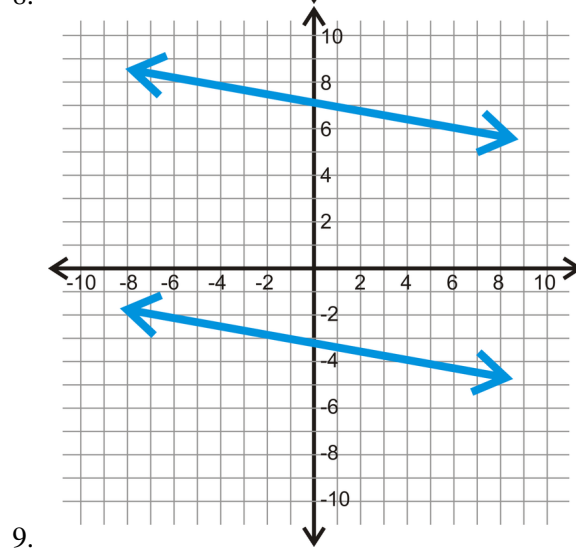
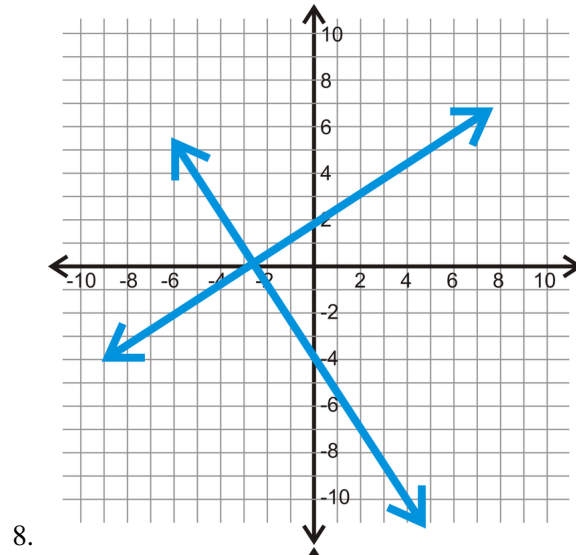

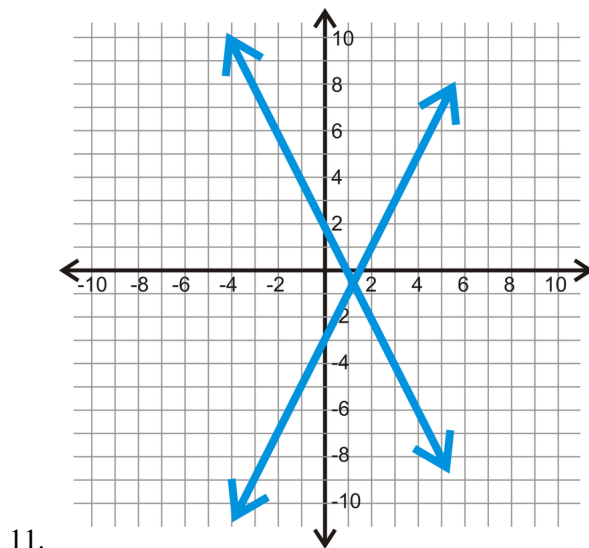

For the line and point below, find a perpendicular line, through the given point.

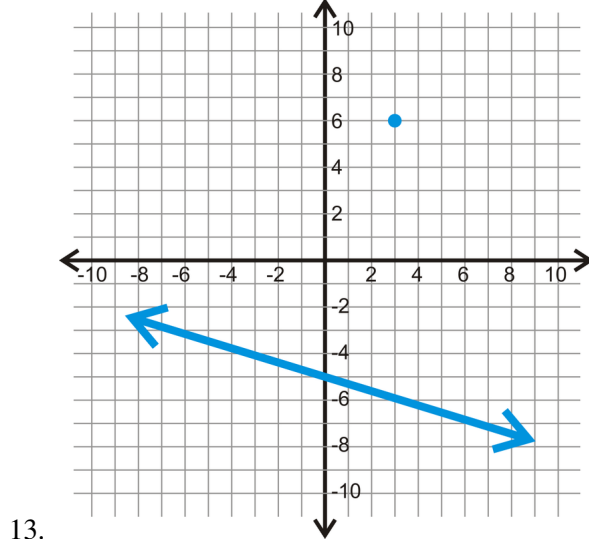
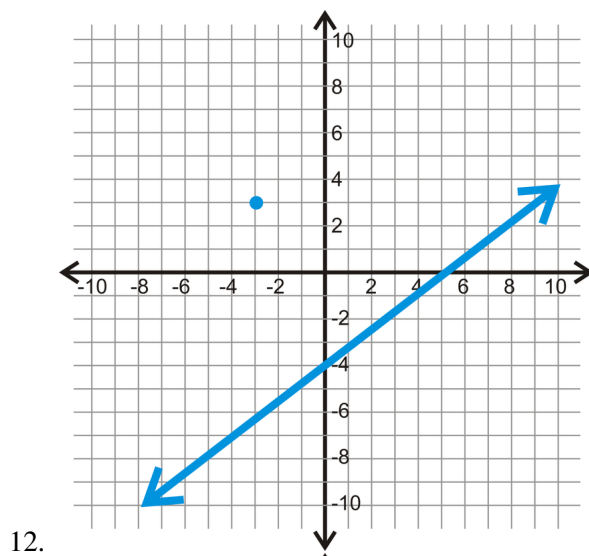

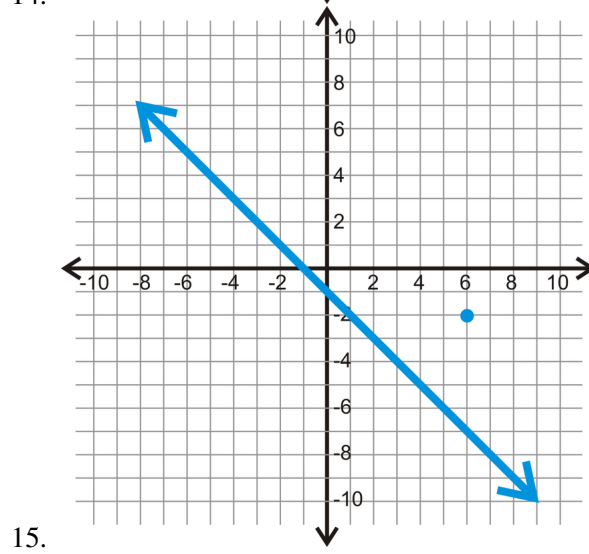
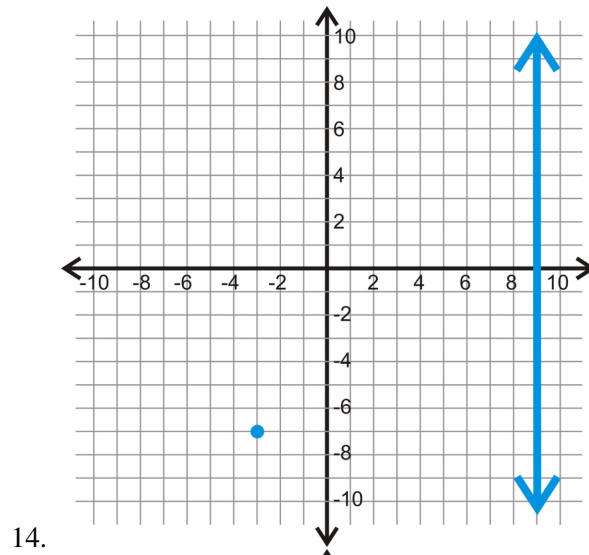

3.10 Distance Formula in the Coordinate Plane

Here you'll learn the Distance Formula and you'll use it to find the distance between two points.

What if you were given the coordinates of two points? How could you find how far apart these two points are? After completing this Concept, you'll be able to find the distance between two points in the coordinate plane using the Distance Formula.

Watch This



MEDIA

Click image to the left for more content.

CK-12 Foundation: [Chapter3DistanceFormulaintheCoordinatePlaneA](#)

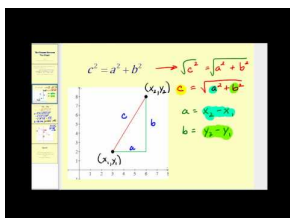

MEDIA

Click image to the left for more content.

James Sousa: [TheDistance Formula](#)

Guidance

The shortest distance between two points is a straight line. This distance can be calculated by using the distance formula. The distance between two points (x_1, y_1) and (x_2, y_2) can be defined as $d = \sqrt{(x_2 - x_1)^2 + (y_2 - y_1)^2}$. Let's extend this concept to the shortest distance between a point and a line.

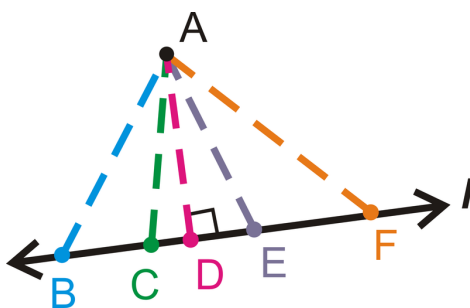

Just by looking at a few line segments from A to line l , we can tell that the shortest distance between a point and a line is the **perpendicular line** between them. Therefore, AD is the shortest distance between A and line l .

Example A

Find the distance between (4, -2) and (-10, 3).

Plug in (4, -2) for (x_1, y_1) and (-10, 3) for (x_2, y_2) and simplify.

$$\begin{aligned} d &= \sqrt{(-10 - 4)^2 + (3 + 2)^2} \\ &= \sqrt{(-14)^2 + (5)^2} && \text{Distances are always positive!} \\ &= \sqrt{196 + 25} \\ &= \sqrt{221} \approx 14.87 \text{ units} \end{aligned}$$

Example B

The distance between two points is 4 units. One point is (1, -6). What is the second point? You may assume that the second point is made up of integers.

We will still use the distance formula for this problem, however, we know d and need to solve for (x_2, y_2) .

$$\begin{aligned} 4 &= \sqrt{(1 - x_2)^2 + (-6 - y_2)^2} \\ 16 &= (1 - x_2)^2 + (-6 - y_2)^2 \end{aligned}$$

At this point, we need to figure out two square numbers that add up to 16. The only two square numbers that add up to 16 are $16 + 0$.

$$\begin{array}{l} 16 = \underbrace{(1 - x_2)^2}_{4^2} + \underbrace{(-6 - y_2)^2}_{0^2} \\ 1 - x_2 = \pm 4 \qquad -6 - y_2 = 0 \\ -x_2 = -5 \text{ or } 3 \quad \text{and} \quad -y_2 = 6 \\ x_2 = 5 \text{ or } -3 \qquad y_2 = -6 \end{array} \qquad \begin{array}{l} \text{or} \\ 16 = \underbrace{(1 - x_2)^2}_{0^2} + \underbrace{(-6 - y_2)^2}_{4^2} \\ 1 - x_2 = 0 \qquad -6 - y_2 = \pm 4 \\ -x_2 = -1 \quad \text{and} \quad y_2 = 10 \text{ or } 2 \\ x_2 = 1 \qquad y_2 = -10 \text{ or } -2 \end{array}$$

Therefore, the second point could have 4 possibilities: (5, -6), (-3, -6), (1, -10), and (1, -2).

Example C

Determine the shortest distance between the point (1, 5) and the line $y = \frac{1}{3}x - 2$.

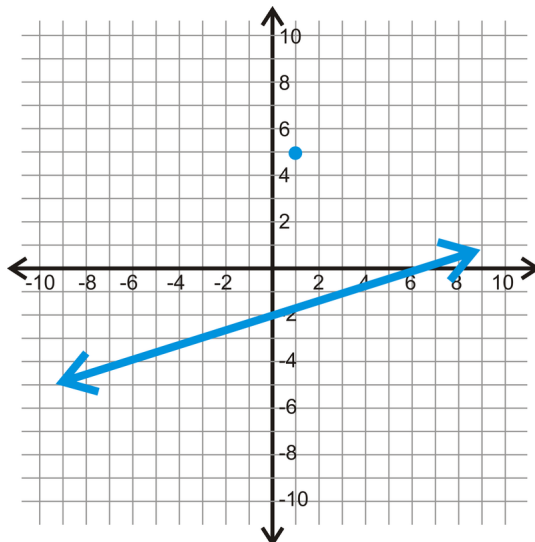

First, graph the line and point. Second determine the equation of the perpendicular line. The opposite sign and reciprocal of $\frac{1}{3}$ is -3 , so that is the slope. We know the line must go through the given point, $(1, 5)$, so use that to find the y -intercept.

$$\begin{aligned}
 y &= -3x + b \\
 5 &= -3(1) + b && \text{The equation of the line is } y = -3x + 8. \\
 8 &= b
 \end{aligned}$$

Next, we need to find the point of intersection of these two lines. By graphing them on the same axes, we can see that the point of intersection is $(3, -1)$, the green point.

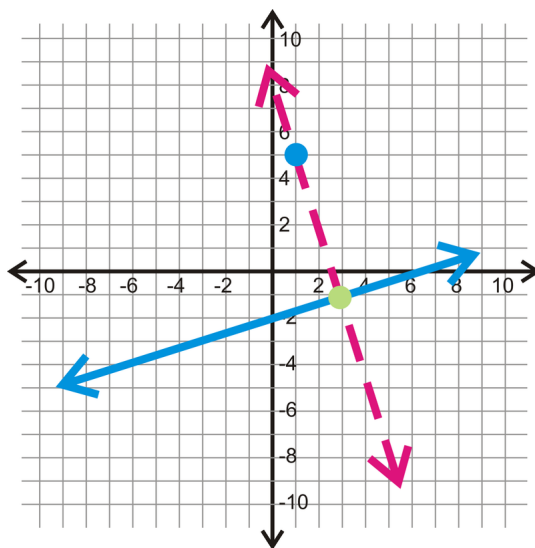

Finally, plug $(1, 5)$ and $(3, -1)$ into the distance formula to find the shortest distance.

$$\begin{aligned}
 d &= \sqrt{(3-1)^2 + (-1-5)^2} \\
 &= \sqrt{(2)^2 + (-6)^2} \\
 &= \sqrt{2+36} \\
 &= \sqrt{38} \approx 6.16 \text{ units}
 \end{aligned}$$

Watch this video for help with the Examples above.



MEDIA

Click image to the left for more content.

[CK-12 Foundation: Chapter3DistanceFormulaintheCoordinatePlaneB](#)

Vocabulary

The **distance formula** tells us that the distance between two points (x_1, y_1) and (x_2, y_2) can be defined as $d = \sqrt{(x_2 - x_1)^2 + (y_2 - y_1)^2}$.

Guided Practice

1. Find the distance between $(-2, -3)$ and $(3, 9)$.
2. Find the distance between $(12, 26)$ and $(8, 7)$.
3. Find the shortest distance between $(2, -5)$ and $y = -\frac{1}{2}x + 1$

Answers:

1. Use the distance formula, plug in the points, and simplify.

$$\begin{aligned}
 d &= \sqrt{(3 - (-2))^2 + (9 - (-3))^2} \\
 &= \sqrt{(5)^2 + (12)^2} \\
 &= \sqrt{25 + 144} \\
 &= \sqrt{169} = 13 \text{ units}
 \end{aligned}$$

2. Use the distance formula, plug in the points, and simplify.

$$\begin{aligned}
 d &= \sqrt{(8 - 12)^2 + (7 - 26)^2} \\
 &= \sqrt{(-4)^2 + (-19)^2} \\
 &= \sqrt{16 + 361} \\
 &= \sqrt{377} \approx 19.42 \text{ units}
 \end{aligned}$$

3. Find the slope of the perpendicular line. The opposite reciprocal of $-\frac{1}{2}$ is 2. We know the perpendicular line has a slope of 2 and contains the point (2, -5), so $-5 = 2(2) + b$ and therefore $b = -9$. Next, we need to figure out where the lines $y = -\frac{1}{2}x + 1$ and $y = 2x - 9$ intersect:

$$\begin{aligned} 2x - 9 &= -\frac{1}{2}x + 1 \\ 2.5x &= 10 \\ x &= 4, \text{ and therefore } y = -1 \end{aligned}$$

So the lines intersect at the point (4, -1). Now, use the distance formula to find the distance between (4, -1) and (2, -5): $\sqrt{(2-4)^2 + (-5-(-1))^2} = \sqrt{4+36} = \sqrt{40} \approx 6.32$ units.

Practice

Find the distance between each pair of points. Round your answer to the nearest hundredth.

1. (4, 15) and (-2, -1)
2. (-6, 1) and (9, -11)
3. (0, 12) and (-3, 8)
4. (-8, 19) and (3, 5)
5. (3, -25) and (-10, -7)
6. (-1, 2) and (8, -9)
7. (5, -2) and (1, 3)
8. (-30, 6) and (-23, 0)

Determine the shortest distance between the given line and point. Round your answers to the nearest hundredth.

9. $y = \frac{1}{3}x + 4$; (5, -1)
10. $y = 2x - 4$; (-7, -3)
11. $y = -4x + 1$; (4, 2)
12. $y = -\frac{2}{3}x - 8$; (7, 9)
13. The distance between two points is 5 units. One point is (2, 2). How many possibilities are there for the second point? You may assume that the second point is made up of integers.
14. What if in the previous question the second point was not necessarily made up of integers? What shape would be created by plotting all of the possibilities for the second point?
15. Find one possibility for the equation of a line that is exactly 6 units away from the point (-3, 2).

3.11 Distance Between Parallel Lines

Here you'll learn that the shortest distance between two parallel lines is the length of a perpendicular line between them.

What if you were given two parallel lines? How could you find how far apart these two lines are? After completing this Concept, you'll be able to find the distance between parallel lines using the distance formula.

Watch This



MEDIA

Click image to the left for more content.

[CK-12 Foundation: Chapter3DistanceBetweenParallelLinesA](#)

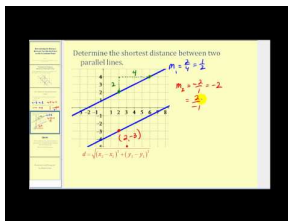

MEDIA

Click image to the left for more content.

[James Sousa:DeterminingtheDistance Between Two Parallel Lines](#)

Guidance

The shortest distance between two parallel lines is the length of the perpendicular segment between them. It doesn't matter which perpendicular line you choose, as long as the two points are on the lines. Recall that there are infinitely many perpendicular lines between two parallel lines.

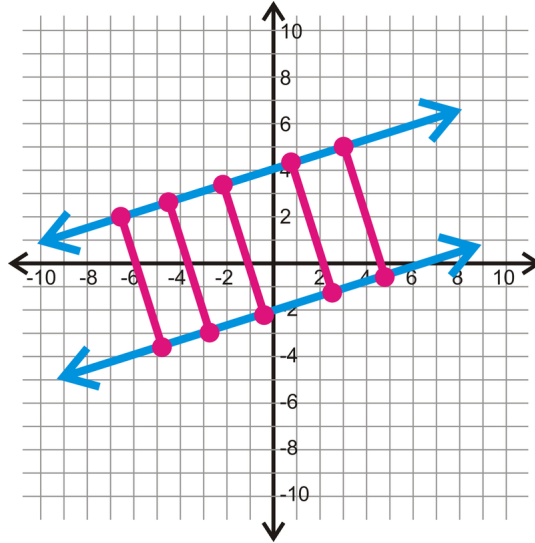

Notice that all of the pink segments are the same length. So, when picking a perpendicular segment, be sure to pick one with endpoints that are integers.

Example A

Find the distance between $x = 3$ and $x = -5$.

Any line with $x = a$ number is a vertical line. In this case, we can just count the squares between the two lines. The two lines are $3 - (-5)$ units apart, or 8 units.

You can use this same method with horizontal lines as well. For example, $y = -1$ and $y = 3$ are $3 - (-1)$ units, or 4 units apart.

Example B

What is the shortest distance between $y = 2x + 4$ and $y = 2x - 1$?

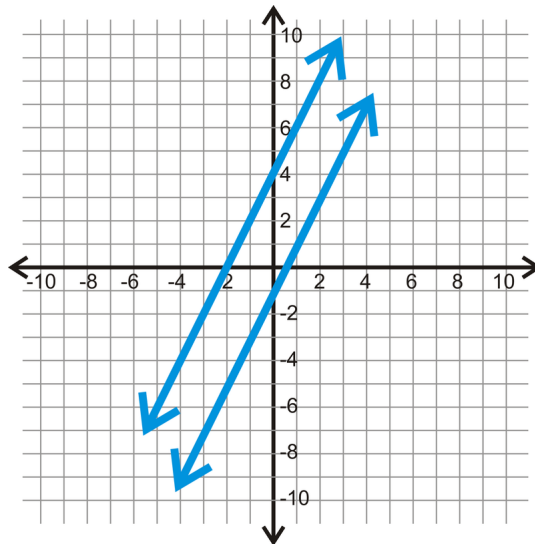

Graph the two lines and determine the perpendicular slope, which is $-\frac{1}{2}$. Find a point on $y = 2x + 4$, let's say $(-1, 2)$. From here, use the slope of the perpendicular line to find the corresponding point on $y = 2x - 1$. If you move

down 1 from 2 and over to the right 2 from -1, you will hit $y = 2x - 1$ at $(1, 1)$. Use these two points to determine the distance between the two lines.

$$\begin{aligned} d &= \sqrt{(1+1)^2 + (1-2)^2} \\ &= \sqrt{2^2 + (-1)^2} \\ &= \sqrt{4+1} \\ &= \sqrt{5} \approx 2.24 \text{ units} \end{aligned}$$

The lines are about 2.24 units apart.

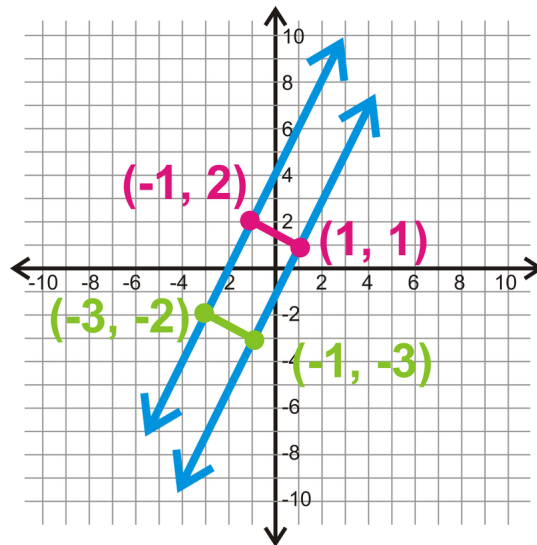

Notice that you could have used any two points, as long as they are on the same perpendicular line. For example, you could have also used $(-3, -2)$ and $(-1, -3)$ and you still would have gotten the same answer.

$$\begin{aligned} d &= \sqrt{(-1+3)^2 + (-3+2)^2} \\ &= \sqrt{2^2 + (-1)^2} \\ &= \sqrt{4+1} \\ &= \sqrt{5} \approx 2.24 \text{ units} \end{aligned}$$

Example C

Find the distance between the two parallel lines below.

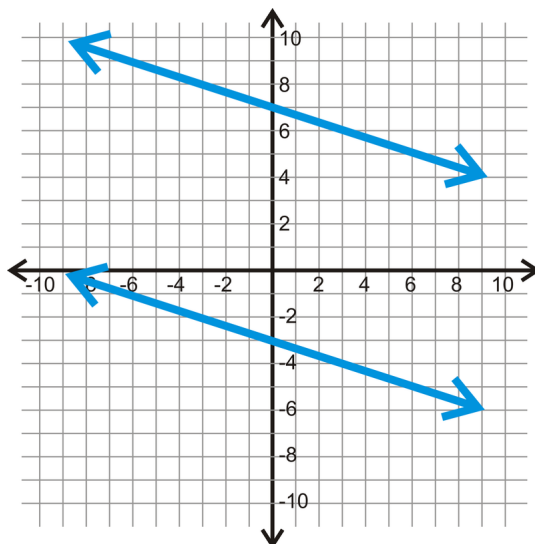

First you need to find the slope of the two lines. Because they are parallel, they are the same slope, so if you find the slope of one, you have the slope of both.

Start at the y -intercept of the top line, 7. From there, you would go down 1 and over 3 to reach the line again. Therefore the slope is $-\frac{1}{3}$ and the perpendicular slope would be 3.

Next, find two points on the lines. Let's use the y -intercept of the bottom line, $(0, -3)$. Then, rise 3 and go over 1 until you reach the second line. Doing this three times, you would hit the top line at $(3, 6)$. Use these two points in the distance formula to find how far apart the lines are.

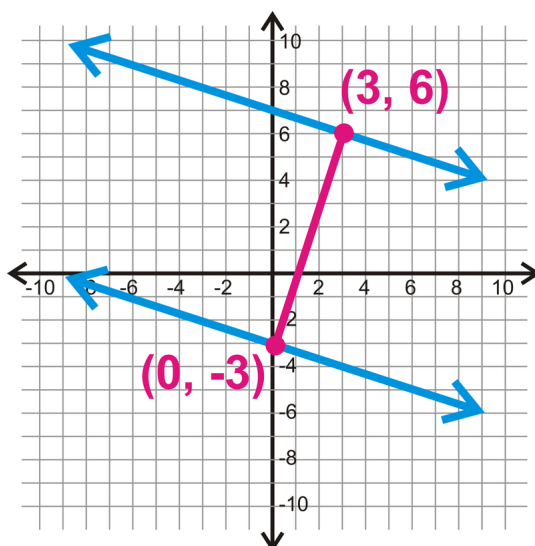

$$\begin{aligned}
 d &= \sqrt{(0-3)^2 + (-3-6)^2} \\
 &= \sqrt{(-3)^2 + (-9)^2} \\
 &= \sqrt{9+81} \\
 &= \sqrt{90} \approx 9.49 \text{ units}
 \end{aligned}$$

Watch this video for help with the Examples above.

MEDIA

Click image to the left for more content.

CK-12 Foundation: Chapter3DistanceBetweenParallelLinesB

Vocabulary

The **distance formula** tells us that the distance between two points (x_1, y_1) and (x_2, y_2) can be defined as $d = \sqrt{(x_2 - x_1)^2 + (y_2 - y_1)^2}$.

Guided Practice

- Find the distance between $x = 7$ and $x = -1$.
- Find the distance between $y = x + 6$ and $y = x - 2$.

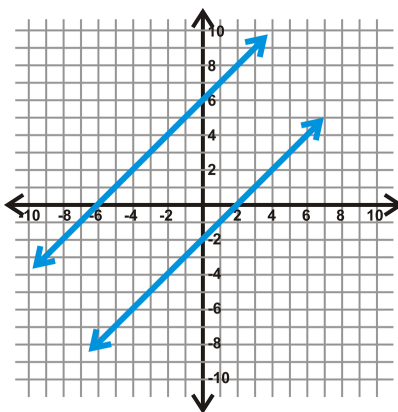

- Find the distance between $y = 5$ and $y = -6$.

Answers:

- These are vertical lines, so we can just count the squares between the two lines. The two lines are $7 - (-1)$ units apart, or 8 units.
- Find the perpendicular slope: $m = 1$, so $m_{\perp} = -1$. Then, find the y -intercept of the top line, $y = x + 6$: $(0, 6)$. Use the slope and count down 1 and to the right 1 until you hit $y = x - 2$ at the point $(4, 2)$. Use these two points in the distance formula to determine how far apart the lines are.

$$\begin{aligned}
 d &= \sqrt{(0 - 4)^2 + (6 - 2)^2} \\
 &= \sqrt{(-4)^2 + (4)^2} \\
 &= \sqrt{16 + 16} \\
 &= \sqrt{32} = 5.66 \text{ units}
 \end{aligned}$$

- These are horizontal lines, so we can just count the squares between the two lines. The two lines are $5 - (-6)$ units apart, or 11 units.

Practice

Use each graph below to determine how far apart each the parallel lines are. Round your answers to the nearest hundredth.

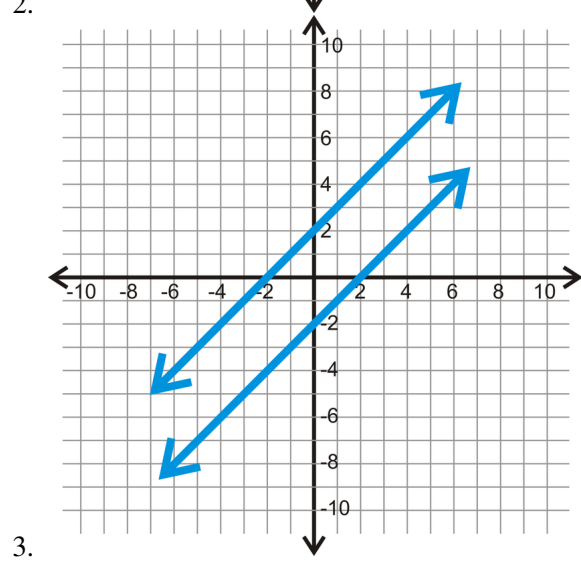
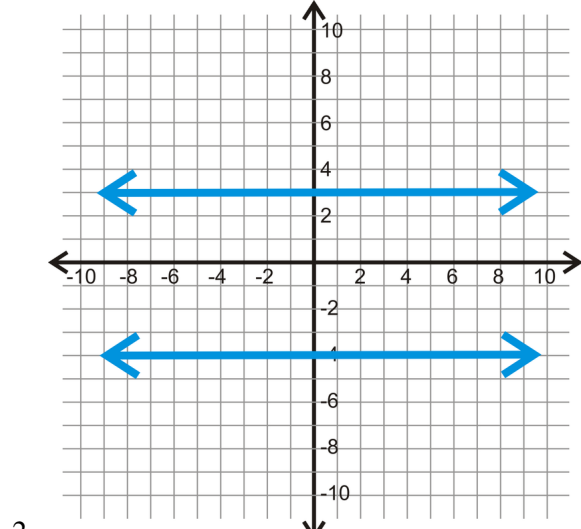
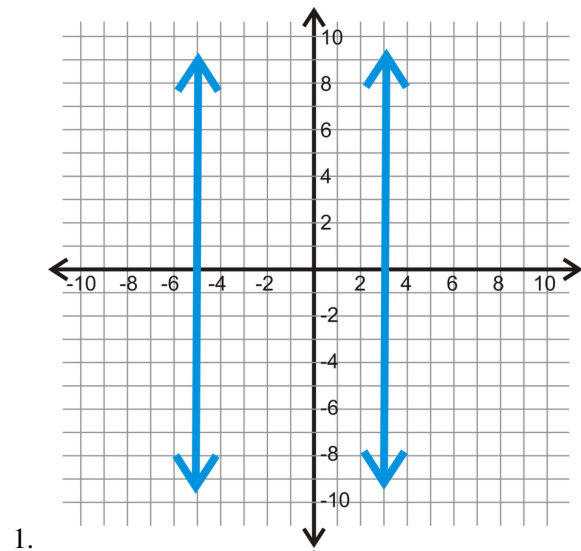

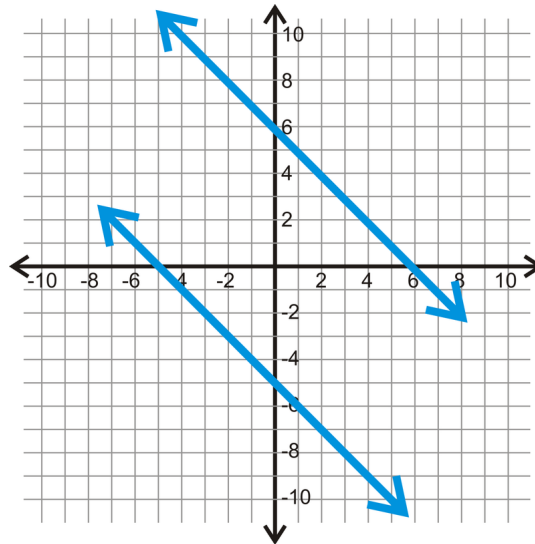

4.

Determine the shortest distance between the each pair of parallel lines. Round your answer to the nearest hundredth.

5. $x = 5, x = 1$
6. $y = -2, y = 7$
7. $x = -4, x = 11$
8. $y = -6, y = 4$
9. $x = 22, x = 16$
10. $y = -14, y = 2$
11. $y = x + 5, y = x - 3$
12. $y = 2x + 1, y = 2x - 4$
13. $y = -\frac{1}{3}x + 2, y = -\frac{1}{3}x - 8$
14. $y = 4x + 9, y = 4x - 8$
15. $y = \frac{1}{2}x, y = \frac{1}{2}x - 5$

Summary

This chapter begins by comparing parallel and skew lines and presenting some of the basic properties of parallel lines. Perpendicular lines are then introduced and some basic properties and theorems related to perpendicular lines are explored. Building on the discussion of parallel lines, perpendicular lines, and transversals, the different angles formed when parallel lines are cut by a transversal are displayed. Corresponding angles, alternate interior angles, alternate exterior angles and their properties are presented. The algebra topics of equations of lines, slope, and distance are tied to the geometric concepts of parallel and perpendicular lines.

Chapter Keywords

- Parallel
- Skew Lines
- Parallel Postulate
- Perpendicular Line Postulate
- Transversal
- Corresponding Angles
- Alternate Interior Angles
- Alternate Exterior Angles

- Same Side Interior Angles
- Corresponding Angles Postulate
- Alternate Interior Angles Theorem
- Alternate Exterior Angles Theorem
- Same Side Interior Angles Theorem
- Converse of Corresponding Angles Postulate
- Converse of Alternate Interior Angles Theorem
- Converse of the Alternate Exterior Angles Theorem
- Converse of the Same Side Interior Angles Theorem
- Parallel Lines Property
- Theorem 3-1
- Theorem 3-2
- Distance Formula: $d = \sqrt{(x_2 - x_1)^2 + (y_2 - y_1)^2}$

Chapter Review

Find the value of each of the numbered angles below.

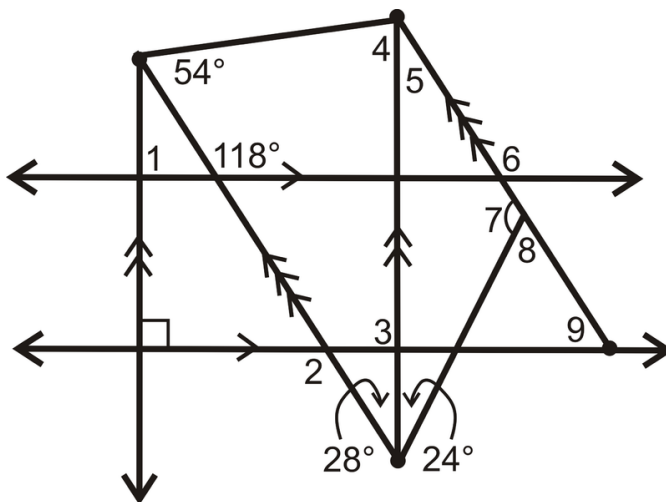

Texas Instruments Resources

In the CK-12 Texas Instruments Geometry FlexBook, there are graphing calculator activities designed to supplement the objectives for some of the lessons in this chapter. See <http://www.ck12.org/flexr/chapter/9688>.

Chapter Outline

- 4.1 TRIANGLE SUM THEOREM
 - 4.2 EXTERIOR ANGLES THEOREMS
 - 4.3 CONGRUENT TRIANGLES
 - 4.4 CONGRUENCE STATEMENTS
 - 4.5 THIRD ANGLE THEOREM
 - 4.6 SSS TRIANGLE CONGRUENCE
 - 4.7 SAS TRIANGLE CONGRUENCE
 - 4.8 ASA AND AAS TRIANGLE CONGRUENCE
 - 4.9 HL TRIANGLE CONGRUENCE
 - 4.10 ISOSCELES TRIANGLES
 - 4.11 EQUILATERAL TRIANGLES
-

Introduction

In this chapter, you will learn all about triangles. First, we will learn about the properties of triangles and the angles within a triangle. Second, we will use that information to determine if two different triangles are congruent. After proving two triangles are congruent, we will use that information to prove other parts of the triangles are congruent as well as the properties of equilateral and isosceles triangles.

4.1 Triangle Sum Theorem

Here you'll learn that the sum of the angles in any triangle is the same, due to the Triangle Sum Theorem.

What if you wanted to classify the Bermuda Triangle by its sides and angles? You are probably familiar with the myth of this triangle; how several ships and planes passed through and mysteriously disappeared.

The measurements of the sides of the triangle from a map are in the image. What type of triangle is this? Using a protractor, find the measure of each angle in the Bermuda Triangle. What do they add up to? Do you think the three angles in this image are the same as the three angles in the *actual* Bermuda triangle? Why or why not? After completing this Concept, you'll be able to determine how the three angles in any triangle are related in order to help you answer these questions.

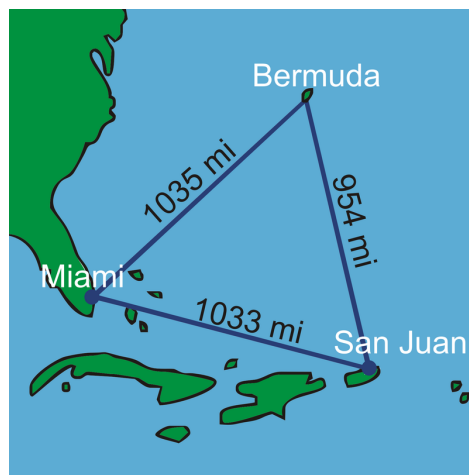

Watch This



MEDIA

Click image to the left for more content.

[CK-12 Foundation: Chapter4TriangleSumTheoremA](#)

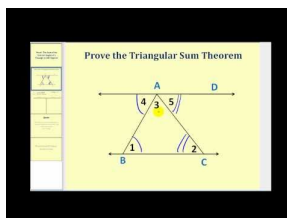

MEDIA

Click image to the left for more content.

[James Sousa:ProvingtheTriangle Sum Theorem](#)

Guidance

In polygons, **interior angles** are the angles inside of a closed figure with straight sides. The **vertex** is the point where the sides of a polygon meet.

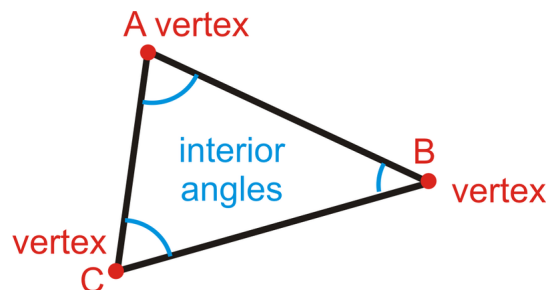

Triangles have three interior angles, three vertices and three sides. A triangle is labeled by its vertices with a \triangle . This triangle can be labeled $\triangle ABC$, $\triangle ACB$, $\triangle BCA$, $\triangle BAC$, $\triangle CBA$ or $\triangle CAB$. Order does not matter. The angles in any polygon are measured in degrees. Each polygon has a different sum of degrees, depending on the number of angles in the polygon. How many degrees are in a triangle?

Investigation: Triangle Tear-Up

Tools Needed: paper, ruler, pencil, colored pencils

1. Draw a triangle on a piece of paper. Try to make all three angles different sizes. Color the three interior angles three different colors and label each one, $\angle 1$, $\angle 2$, and $\angle 3$.

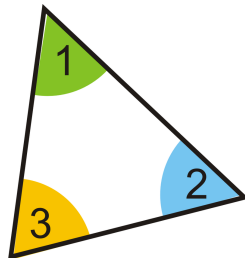

2. Tear off the three colored angles, so you have three separate angles.



3. Attempt to line up the angles so their points all match up. What happens? What measure do the three angles add up to?



This investigation shows us that the sum of the angles in a triangle is 180° because the three angles fit together to form a straight line. Recall that a line is also a straight angle and all straight angles are 180° .

The **Triangle Sum Theorem** states that the interior angles of a triangle add up to 180° . The above investigation is one way to show that the angles in a triangle add up to 180° . However, it is not a two-column proof. Here we will prove the Triangle Sum Theorem.

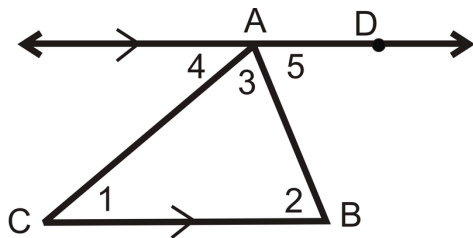

Given: $\triangle ABC$ with $\overleftrightarrow{AD} \parallel \overline{BC}$

Prove: $m\angle 1 + m\angle 2 + m\angle 3 = 180^\circ$

TABLE 4.1:

| <i>Statement</i> | <i>Reason</i> |
|---|-----------------------------------|
| 1. $\triangle ABC$ above with $\overleftrightarrow{AD} \parallel \overline{BC}$ | Given |
| 2. $\angle 1 \cong \angle 4, \angle 2 \cong \angle 5$ | Alternate Interior Angles Theorem |
| 3. $m\angle 1 = m\angle 4, m\angle 2 = m\angle 5$ | \cong angles have = measures |
| 4. $m\angle 4 + m\angle CAD = 180^\circ$ | Linear Pair Postulate |
| 5. $m\angle 3 + m\angle 5 = m\angle CAD$ | Angle Addition Postulate |
| 6. $m\angle 4 + m\angle 3 + m\angle 5 = 180^\circ$ | Substitution PoE |
| 7. $m\angle 1 + m\angle 3 + m\angle 2 = 180^\circ$ | Substitution PoE |

There are two theorems that we can prove as a result of the Triangle Sum Theorem and our knowledge of triangles.

Theorem #1: Each angle in an equiangular triangle measures 60° .

Theorem #2: The acute angles in a right triangle are always complementary.

Example A

What is the $m\angle T$?

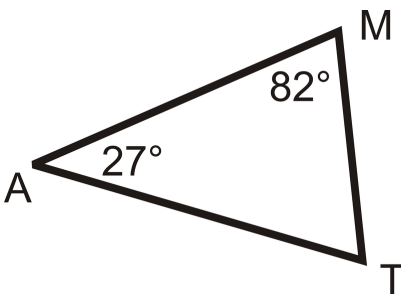

From the Triangle Sum Theorem, we know that the three angles add up to 180° . Set up an equation to solve for $\angle T$.

$$\begin{aligned}
 m\angle M + m\angle A + m\angle T &= 180^\circ \\
 82^\circ + 27^\circ + m\angle T &= 180^\circ \\
 109^\circ + m\angle T &= 180^\circ \\
 m\angle T &= 71^\circ
 \end{aligned}$$

Example B

Show why Theorem #1 is true.

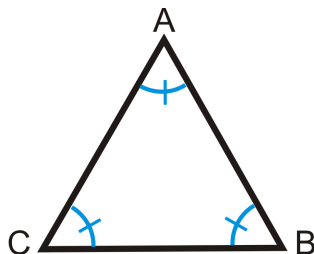

$\triangle ABC$ above is an example of an equiangular triangle, where all three angles are equal. Write an equation.

$$m\angle A + m\angle B + m\angle C = 180^\circ$$

$$m\angle A + m\angle A + m\angle A = 180^\circ$$

$$3m\angle A = 180^\circ$$

$$m\angle A = 60^\circ$$

If $m\angle A = 60^\circ$, then $m\angle B = 60^\circ$ and $m\angle C = 60^\circ$.

Example C

Use the picture below to show why Theorem #2 is true.

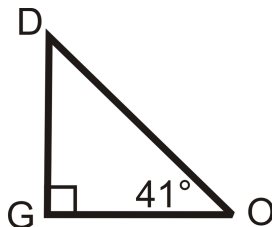

$m\angle O = 41^\circ$ and $m\angle G = 90^\circ$ because it is a right angle.

$$m\angle D + m\angle O + m\angle G = 180^\circ$$

$$m\angle D + 41^\circ + 90^\circ = 180^\circ$$

$$m\angle D + 41^\circ = 90^\circ$$

$$m\angle D = 49^\circ$$

Notice that $m\angle D + m\angle O = 90^\circ$ because $\angle G$ is a right angle.

Watch this video for help with the Examples above.



MEDIA

Click image to the left for more content.

CK-12 Foundation: Chapter4TriangleSumTheoremB

Concept Problem Revisited

The Bermuda Triangle is an acute scalene triangle. The angle measures are in the picture below. Your measured angles should be within a degree or two of these measures. The angles should add up to 180° . However, because your measures are estimates using a protractor, they might not exactly add up.

The angle measures in the picture are the measures from a map (which is flat). Because the earth is curved, in real life the measures will be slightly different.

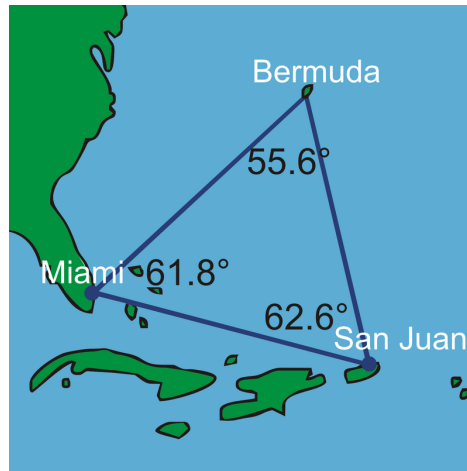
**Vocabulary**

A **triangle** is a three sided shape. All triangles have three **interior angles**, which are the inside angles connecting the sides of the triangle. The **vertex** is the point where the sides of a polygon meet. Special types of triangles are listed below:

Scalene: All three sides are different lengths.

Isosceles: At least two sides are congruent.

Equilateral: All three sides are congruent.

Right: One right angle.

Acute: All three angles are less than 90° .

Obtuse: One angle is greater than 90° .

Equiangular: All three angles are congruent.

Guided Practice

1. Determine $m\angle 1$ in this triangle:

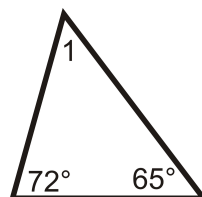

- Two interior angles of a triangle measure 50° and 70° . What is the third interior angle of the triangle?
- Find the value of x and the measure of each angle.

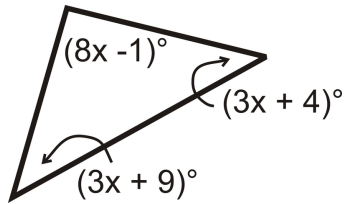
**Answers:**

- $72^\circ + 65^\circ + m\angle 1 = 180^\circ$.

Solve this equation and you find that $m\angle 1 = 43^\circ$.

- $50^\circ + 70^\circ + x = 180^\circ$.

Solve this equation and you find that the third angle is 60° .

- All the angles add up to 180° .

$$\begin{aligned} (8x - 1)^\circ + (3x + 9)^\circ + (3x + 4)^\circ &= 180^\circ \\ (14x + 12)^\circ &= 180^\circ \\ 14x &= 168 \\ x &= 12 \end{aligned}$$

Substitute in 12 for x to find each angle.

$$[3(12) + 9]^\circ = 45^\circ$$

$$[3(12) + 4]^\circ = 40^\circ$$

$$[8(12) - 1]^\circ = 95^\circ$$

Practice

Determine $m\angle 1$ in each triangle.

- A triangle with interior angles 94° and 45° , and an angle labeled 1.

- An isosceles triangle with one angle labeled 47° and two angles labeled 1. The two base angles are marked with blue tick marks to indicate they are congruent.

-

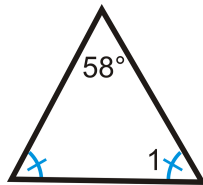

4.

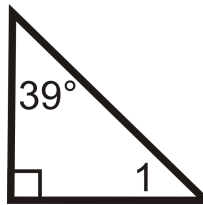

5.



6.

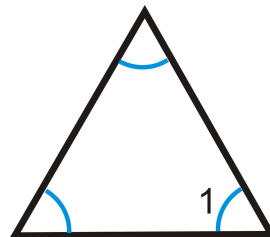

7.



8. Two interior angles of a triangle measure 32° and 64° . What is the third interior angle of the triangle?

9. Two interior angles of a triangle measure 111° and 12° . What is the third interior angle of the triangle?

10. Two interior angles of a triangle measure 2° and 157° . What is the third interior angle of the triangle?

Find the value of x and the measure of each angle.

11.

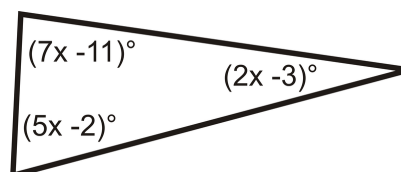

12.

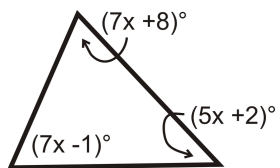

13.

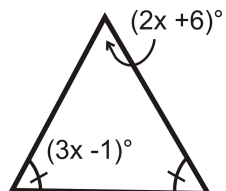

14.

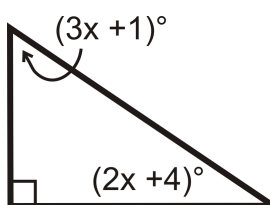

15.

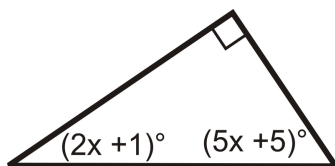

4.2 Exterior Angles Theorems

Here you'll learn what an exterior angle is as well as two theorems involving exterior angles: that the sum of the exterior angles is always 360° and that in a triangle, an exterior angle is equal to the sum of its remote interior angles.

What if you knew that two of the exterior angles of a triangle measured 130° ? How could you find the measure of the third exterior angle? After completing this Concept, you'll be able to apply the Exterior Angle Sum Theorem to solve problems like this one.

Watch This



MEDIA

Click image to the left for more content.

CK-12 Foundation: Chapter4ExteriorAnglesTheoremsA

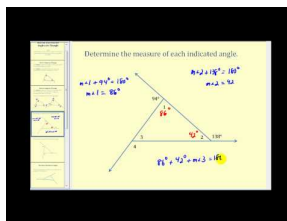

MEDIA

Click image to the left for more content.

James Sousa:Introduction totheExterior Anglesof a Triangle

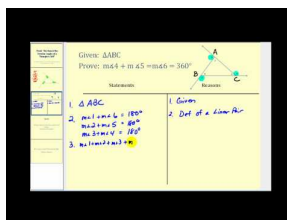

MEDIA

Click image to the left for more content.

James Sousa:Proof that the Sum of the Exterior Angles of a Triangle is 360 Degrees

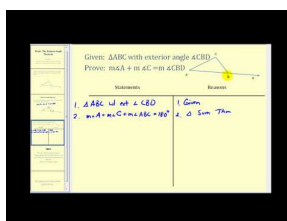

MEDIA

Click image to the left for more content.

James Sousa:Proof of the Exterior Angles Theorem

Guidance

An **exterior angle** is the angle formed by one side of a polygon and the extension of the adjacent side. In all polygons, there are **two** sets of exterior angles, one going around the polygon clockwise and the other goes around the polygon counterclockwise. By the definition, the interior angle and its adjacent exterior angle form a linear pair.

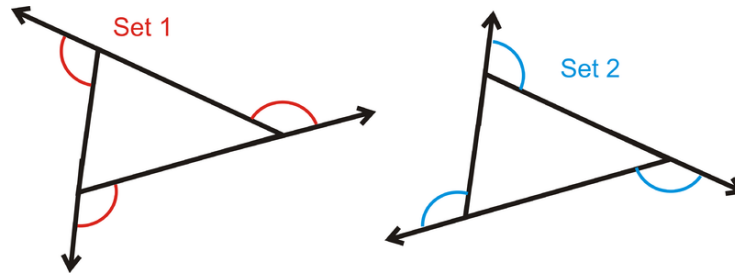

The **Exterior Angle Sum Theorem** states that each set of exterior angles of a polygon add up to 360° .

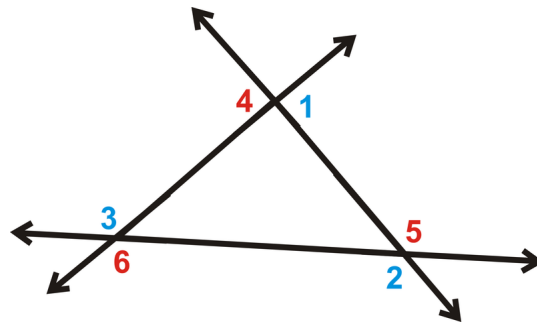

$$m\angle 1 + m\angle 2 + m\angle 3 = 360^\circ$$

$$m\angle 4 + m\angle 5 + m\angle 6 = 360^\circ$$

Remote interior angles are the two angles in a triangle that are not adjacent to the indicated exterior angle. $\angle A$ and $\angle B$ are the remote interior angles for exterior angle $\angle ACD$.

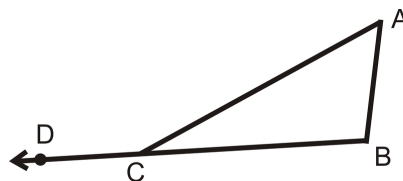

The **Exterior Angle Theorem** states that the sum of the remote interior angles is equal to the non-adjacent exterior angle. From the picture above, this means that $m\angle A + m\angle B = m\angle ACD$. Here is the proof of the Exterior Angle Theorem. From the proof, you can see that this theorem is a combination of the Triangle Sum Theorem and the Linear Pair Postulate.

Given: $\triangle ABC$ with exterior angle $\angle ACD$

Prove: $m\angle A + m\angle B = m\angle ACD$

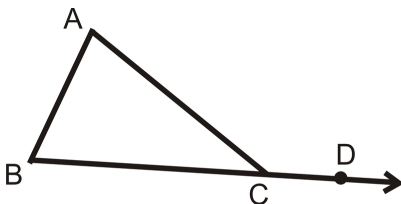
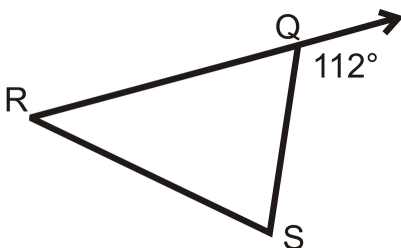

TABLE 4.2:

| <i>Statement</i> | <i>Reason</i> |
|--|-----------------------|
| 1. $\triangle ABC$ with exterior angle $\angle ACD$ | Given |
| 2. $m\angle A + m\angle B + m\angle ACB = 180^\circ$ | Triangle Sum Theorem |
| 3. $m\angle ACB + m\angle ACD = 180^\circ$ | Linear Pair Postulate |
| 4. $m\angle A + m\angle B + m\angle ACB = m\angle ACB + m\angle ACD$ | Transitive PoE |
| 5. $m\angle A + m\angle B = m\angle ACD$ | Subtraction PoE |

Example A

Find the measure of $\angle RQS$.



112° is an exterior angle of $\triangle RQS$. Therefore, it is supplementary to $\angle RQS$ because they are a linear pair.

$$112^\circ + m\angle RQS = 180^\circ$$

$$m\angle RQS = 68^\circ$$

If we draw both sets of exterior angles on the same triangle, we have the following figure:

Notice, at each vertex, the exterior angles are also vertical angles, therefore they are congruent.

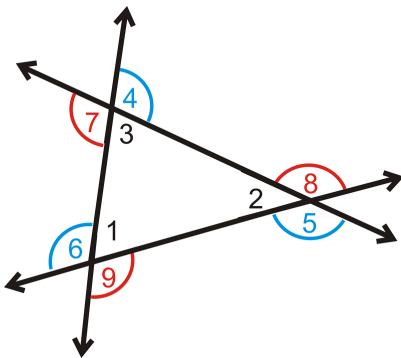

$$\angle 4 \cong \angle 7$$

$$\angle 5 \cong \angle 8$$

$$\angle 6 \cong \angle 9$$

Example B

Find the measure of the numbered interior and exterior angles in the triangle.

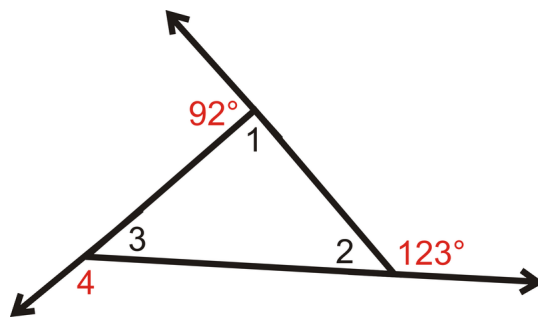

$m\angle 1 + 92^\circ = 180^\circ$ by the Linear Pair Postulate, so $m\angle 1 = 88^\circ$.

$m\angle 2 + 123^\circ = 180^\circ$ by the Linear Pair Postulate, so $m\angle 2 = 57^\circ$.

$m\angle 1 + m\angle 2 + m\angle 3 = 180^\circ$ by the Triangle Sum Theorem, so $88^\circ + 57^\circ + m\angle 3 = 180^\circ$ and $m\angle 3 = 35^\circ$.

$m\angle 3 + m\angle 4 = 180^\circ$ by the Linear Pair Postulate, so $m\angle 4 = 145^\circ$.

Example C

What is the value of p in the triangle below?

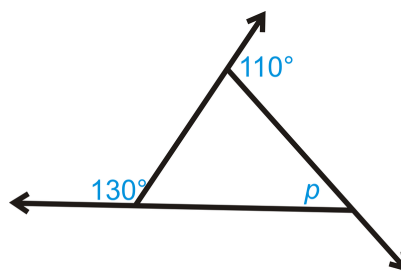

First, we need to find the missing exterior angle, we will call it x . Set up an equation using the Exterior Angle Sum Theorem.

$$130^\circ + 110^\circ + x = 360^\circ$$

$$x = 360^\circ - 130^\circ - 110^\circ$$

$$x = 120^\circ$$

x and p are supplementary and add up to 180° .

$$\begin{aligned}x + p &= 180^\circ \\120^\circ + p &= 180^\circ \\p &= 60^\circ\end{aligned}$$

Watch this video for help with the Examples above.



MEDIA

Click image to the left for more content.

[CK-12 Foundation: Chapter4TriangleSumTheoremA](#)

Concept Problem Revisited

The third exterior angle of the triangle below is $\angle 1$.

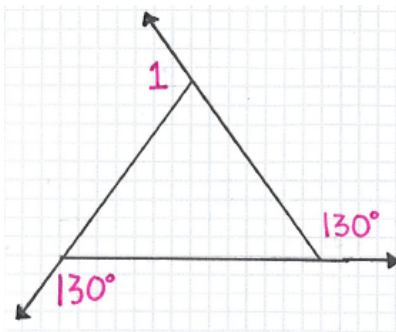

By the Exterior Angle Sum Theorem:

$$\begin{aligned}m\angle 1 + 130^\circ + 130^\circ &= 360^\circ \\m\angle 1 &= 100^\circ\end{aligned}$$

Vocabulary

Interior angles are the angles on the inside of a polygon while **exterior angles** are the angles on the outside of a polygon. **Remote interior angles** are the two angles in a triangle that are not adjacent to the indicated exterior angle. Two angles that make a straight line form a **linear pair** and thus add up to 180° . The **Triangle Sum Theorem** states that the three interior angles of any triangle will always add up to 180° . The **Exterior Angle Sum Theorem** states that each set of exterior angles of a polygon add up to 360° .

Guided Practice

1. Find $m\angle A$.

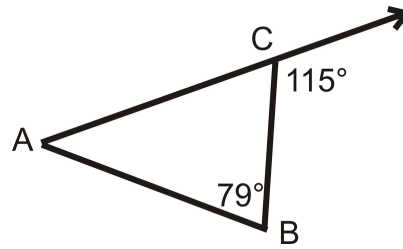

2. Find $m\angle C$.

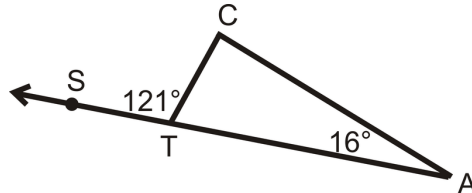

3. Find the value of x and the measure of each angle.

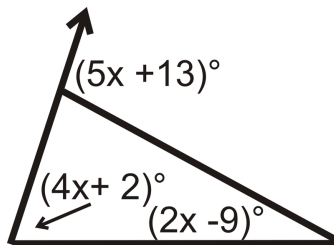

Answers:

- Set up an equation using the Exterior Angle Theorem. $m\angle A + 79^\circ = 115^\circ$. Therefore, $m\angle A = 36^\circ$.
- Using the Exterior Angle Theorem, $m\angle C + 16^\circ = 121^\circ$. Subtracting 16° from both sides, $m\angle C = 105^\circ$.
- Set up an equation using the Exterior Angle Theorem.

$$\begin{array}{ccc}
 (4x + 2)^\circ + (2x - 9)^\circ = (5x + 13)^\circ \\
 \uparrow \quad \nearrow \qquad \qquad \qquad \uparrow \\
 \text{interior angles} \qquad \qquad \text{exterior angle} \\
 (6x - 7)^\circ = (5x + 13)^\circ \\
 x = 20^\circ
 \end{array}$$

Substituting 20° back in for x , the two interior angles are $(4(20) + 2)^\circ = 82^\circ$ and $(2(20) - 9)^\circ = 31^\circ$. The exterior angle is $(5(20) + 13)^\circ = 113^\circ$. Double-checking our work, notice that $82^\circ + 31^\circ = 113^\circ$. If we had done the problem incorrectly, this check would not have worked.

Practice

Determine $m\angle 1$.

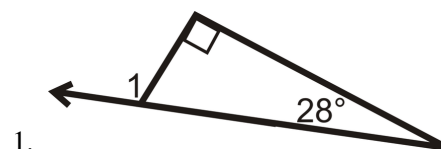

1.

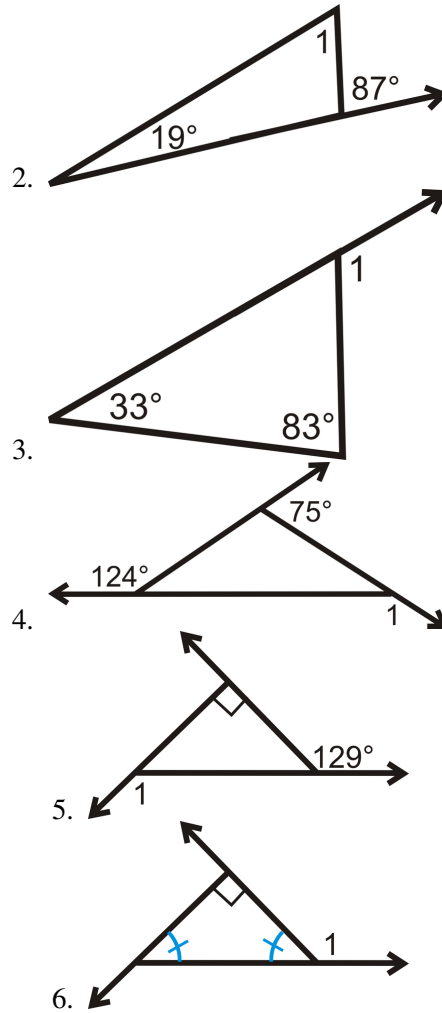

Use the following picture for the next three problems:

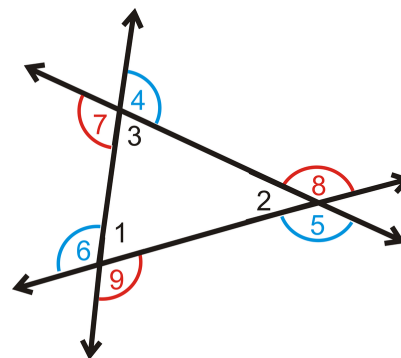

7. What is $m\angle 1 + m\angle 2 + m\angle 3$?
8. What is $m\angle 4 + m\angle 5 + m\angle 6$?
9. What is $m\angle 7 + m\angle 8 + m\angle 9$?

Solve for x .

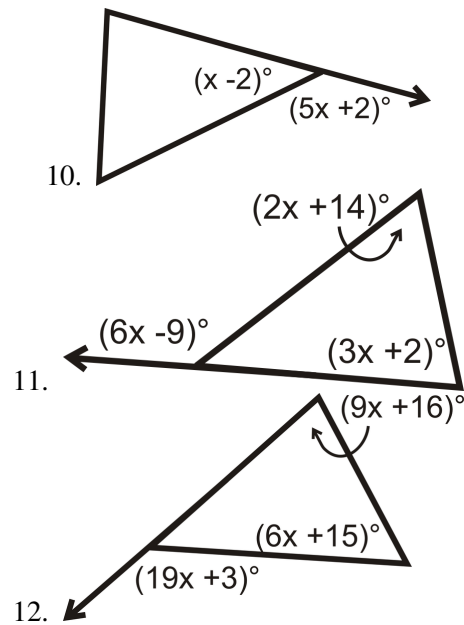

13. Suppose the measures of the three angles of a triangle are x , y , and z . Explain why $x + y + z = 180$.
14. Suppose the measures of the three angles of a triangle are x , y , and z . Explain why the expression $(180 - x) + (180 - y) + (180 - z)$ represents the sum of the exterior angles of the triangle.
15. Use your answers to the previous two problems to help justify why the sum of the exterior angles of a triangle is 360 degrees. Hint: Use algebra to show that $(180 - x) + (180 - y) + (180 - z)$ must equal 360 if $x + y + z = 180$.

4.3 Congruent Triangles

Here you'll learn what it means for two triangles to be congruent, and how to find the corresponding parts of congruent triangles.

What if you had a quilt whose pattern was geometric and made up of several congruent figures? In order for these patterns to come together, the quilter rotates and flips each block (in this case, a large triangle, smaller triangle, and a smaller square) to get new patterns and arrangements.

How many different sets of colored congruent triangles are there? How many triangles are in each set? How do you know these triangles are congruent? After completing this Concept, you'll be able to use your knowledge of congruent triangles in order to answer these questions.

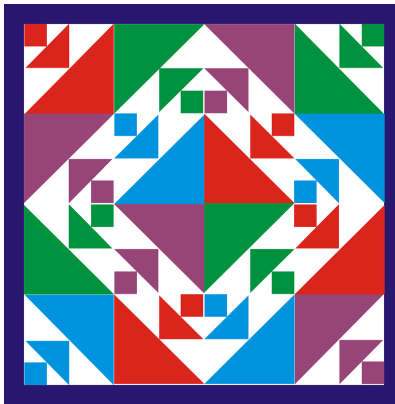

Watch This



MEDIA

Click image to the left for more content.

[CK-12 Foundation: Chapter4CongruentTrianglesA](#)

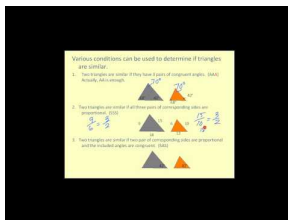

MEDIA

Click image to the left for more content.

[James Sousa:Congruent Triangles](#)

Guidance

Recall that two figures are congruent if and only if they have exactly the same size and shape. If two triangles are congruent, they will have exactly the same three sides and exactly the same three angles. In other words, two triangles are congruent if you can turn, flip, and/or slide one so it fits exactly on the other.

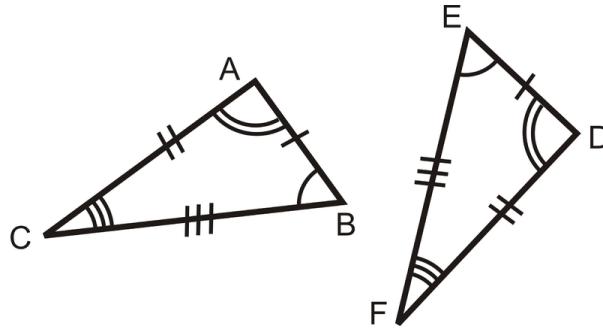

$\triangle ABC$ and $\triangle DEF$ are congruent because

$$\begin{array}{ll} \overline{AB} \cong \overline{DE} & \angle A \cong \angle D \\ \overline{BC} \cong \overline{EF} & \text{and } \angle B \cong \angle E \\ \overline{AC} \cong \overline{DF} & \angle C \cong \angle F \end{array}$$

Notice that when two triangles are congruent their three pairs of corresponding angles and their three pairs of corresponding sides are congruent.

When referring to corresponding congruent parts of congruent triangles, you can use the phrase Corresponding Parts of Congruent Triangles are Congruent, or its abbreviation CPCTC.

Properties of Congruence Review

Recall the Properties of Congruence:

Reflexive Property of Congruence: Any shape is congruent to itself.

$$\overline{AB} \cong \overline{AB} \text{ or } \triangle ABC \cong \triangle ABC$$

Symmetric Property of Congruence: If two shapes are congruent, the statement can be written with either shape on either side of the \cong sign.

$$\angle EFG \cong \angle XYZ \text{ and } \angle XYZ \cong \angle EFG \text{ or } \triangle ABC \cong \triangle DEF \text{ and } \triangle DEF \cong \triangle ABC$$

Transitive Property of Congruence: If two shapes are congruent and one of those is congruent to a third, the first and third shapes are also congruent.

$$\triangle ABC \cong \triangle DEF \text{ and } \triangle DEF \cong \triangle GHI, \text{ then } \triangle ABC \cong \triangle GHI$$

These three properties will be very important when you begin to prove that two triangles are congruent.

Example A

Are the two triangles below congruent?

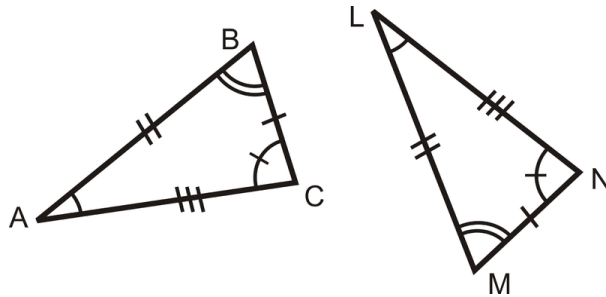

To determine if the triangles are congruent, each pair of corresponding sides and angles must be congruent.

Start with the sides and match up sides with the same number of tic marks. Using the tic marks: $\overline{BC} \cong \overline{MN}$, $\overline{AB} \cong \overline{LM}$, $\overline{AC} \cong \overline{LN}$.

Next match the angles with the same markings; $\angle A \cong \angle L$, $\angle B \cong \angle M$, and $\angle C \cong \angle N$. Because all six parts are congruent, the two triangles are congruent.

Example B

In order to say that $\triangle ABD \cong \triangle ABC$, you must determine that the three corresponding angles and sides are congruent. Which pair of sides is congruent by the Reflexive Property?

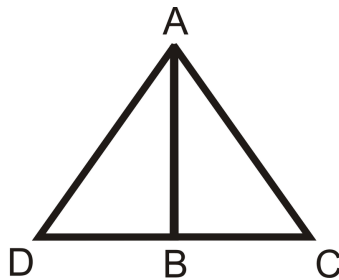

The side \overline{AB} is shared by both triangles. So, in a geometric proof, $\overline{AB} \cong \overline{AB}$ by the Reflexive Property of Congruence.

Example C

If all three pairs of angles for two given triangles are congruent does that mean that the triangles are congruent?

Without knowing anything about the lengths of the sides you cannot tell whether or not two triangles are congruent. The two triangles described above *might* be congruent, but we would need more information to know for sure.

Watch this video for help with the Examples above.



MEDIA

Click image to the left for more content.

Concept Problem Revisited

There are 16 “A” triangles and they are all congruent. There are 16 “B” triangles and they are all congruent. The quilt pattern is made from dividing up the square into smaller squares. The “A” triangles are all $\frac{1}{32}$ of the overall square and the “B” triangles are each $\frac{1}{128}$ of the large square. Both the “A” and “B” triangles are right triangles.

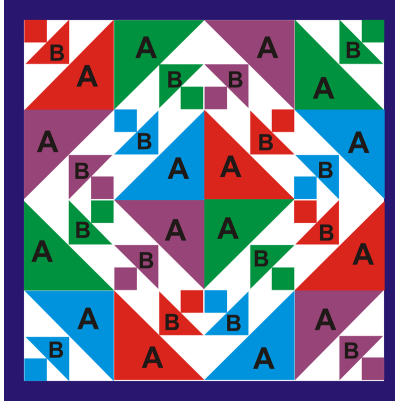

Vocabulary

Two figures are **congruent** if they have exactly the same size and shape. Two triangles are **congruent** if their three pairs of corresponding angles and three pairs of corresponding sides are congruent.

Guided Practice

- Determine if the triangles are congruent using the definition of congruent triangles.

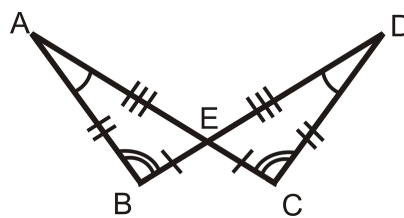

- Determine if the triangles are congruent using the definition of congruent triangles.

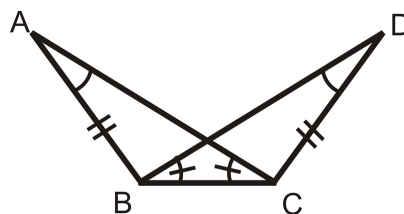

- Determine if the triangles are congruent using the definition of congruent triangles.

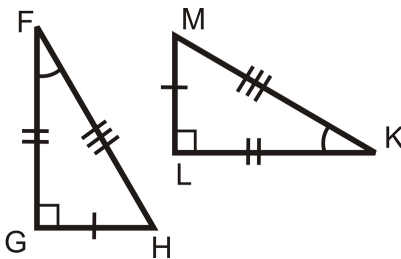

Answers:

1. We can see from the markings that $\angle B \cong \angle C$, $\angle A \cong \angle D$, and $\angle AEB \cong \angle DEC$ because they are vertical angles. Also, we know that $\overline{BA} \cong \overline{CD}$, $\overline{EA} \cong \overline{ED}$, and $\overline{BE} \cong \overline{CE}$. Because three pairs of sides and three pairs of angles are all congruent and they are corresponding parts, this means that the two triangles are congruent.
2. While there are congruent corresponding parts, there are only two pairs of congruent sides, the marked ones and the shared side. Without knowing whether or not the third pair of sides is congruent we cannot say if the triangles are congruent using the definition of congruent triangles. Note, this does not mean that the triangles are **not congruent**, it just means that we need more information in order to say they are congruent using the *definition of congruent triangles* (congruent triangles have three pairs of congruent angles and three pairs of congruent sides).
3. We can see from the markings that $\angle G \cong \angle L$, $\angle F \cong \angle K$, and therefore $\angle H \cong \angle M$ by the Third Angle Theorem. Also, we know that $\overline{MK} \cong \overline{FH}$, $\overline{GF} \cong \overline{LK}$, and $\overline{GH} \cong \overline{LM}$. Because three pairs of sides and three pairs of angles are all congruent and they are corresponding parts, this means that the two triangles are congruent.

Practice

The following illustrations show two parallel lines cut by a transversal. Are the triangles formed definitively congruent?

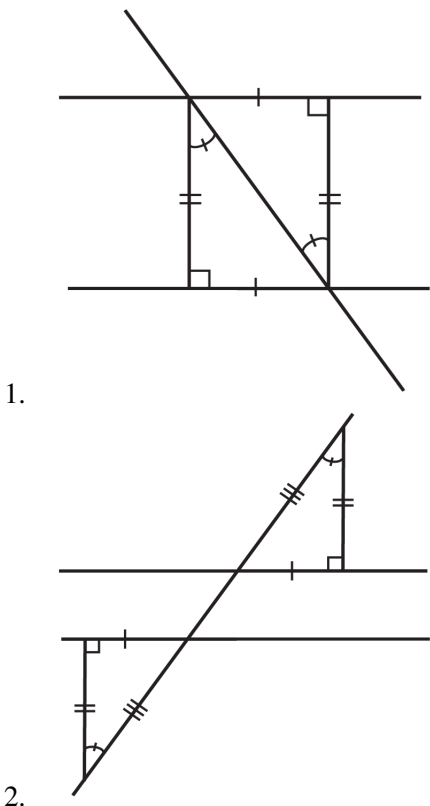

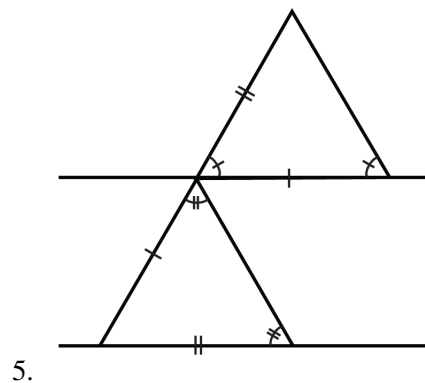
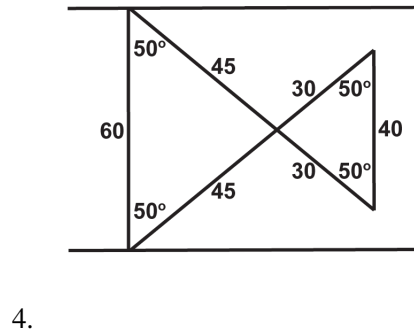
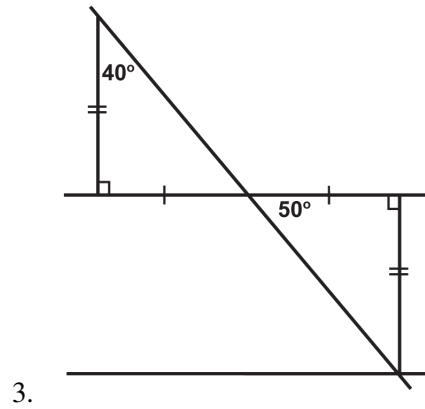

Based on the following details, are the triangles definitively congruent?

6. Both triangles are right triangles in which one angle measures 55° . All of their corresponding sides are congruent.
7. Both triangles are equiangular triangles.
8. Both triangles are equilateral triangles. All sides are 5 inches in length.
9. Both triangles are obtuse triangles in which one angle measures 35° . Two of their corresponding sides are congruent.
10. Both triangles are obtuse triangles in which two of their angles measure 40° and 20° . All of their corresponding sides are congruent.
11. Both triangles are isosceles triangles in which one angle measures 15° .
12. Both triangles are isosceles triangles with two equal angles of 55° . All corresponding sides are congruent.
13. Both triangles are acute triangles in which two of their angles measure 40° and 80° . All of their corresponding sides are congruent.
14. Both triangles are acute triangles in which one angle measures 60° . Two of their corresponding sides are congruent.
15. Both triangles are equilateral triangles.

4.4 Congruence Statements

Here you'll learn how to write a congruence statement and use congruence statements in order to identify corresponding parts.

What if you were told that

$$\triangle ABC \cong \triangle XYZ$$

? How could you determine which side in $\triangle XYZ$ is congruent to \overline{BA} and which angle is congruent to $\angle C$? After completing this Concept, you'll be able to use congruence statements to state which sides and angles are congruent in congruent triangles.

Watch This



MEDIA

Click image to the left for more content.

[CK-12 Foundation: Chapter4CreatingCongruenceStatementsA](#)

Watch the first part of this video.

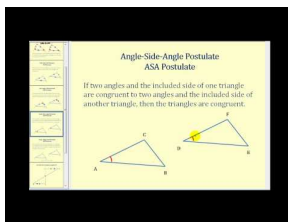

MEDIA

Click image to the left for more content.

[James Sousa:Introduction toCongruent Triangles](#)

Guidance

When stating that two triangles are congruent, use a **congruence statement**. The order of the letters is very important, as corresponding parts must be written in the same order. Notice that the congruent sides also line up within the congruence statement.

$$\begin{array}{c} \angle A \text{ and } \angle L \text{ are } \cong \quad \angle C \text{ and } \angle N \text{ are } \cong \\ \triangle ABC \cong \triangle LMN \\ \angle B \text{ and } \angle M \text{ are } \cong \end{array}$$

$$\overline{AB} \cong \overline{LM}, \overline{BC} \cong \overline{MN}, \overline{AC} \cong \overline{LN}$$

We can also write this congruence statement several other ways, as long as the congruent angles match up. For example, we can also write $\triangle ABC \cong \triangle LMN$ as:

$$\begin{array}{ll} \triangle ACB \cong \triangle LNM & \triangle BCA \cong \triangle MNL \\ \triangle BAC \cong \triangle MLN & \triangle CBA \cong \triangle NML \\ \triangle CAB \cong \triangle NLM & \end{array}$$

One congruence statement can always be written six ways. Any of the six ways above would be correct.

Example A

Write a congruence statement for the two triangles below.

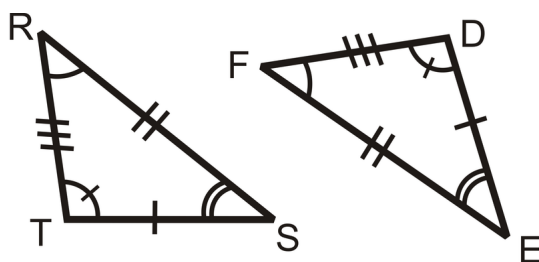

To write the congruence statement, you need to line up the corresponding parts in the triangles: $\angle R \cong \angle F$, $\angle S \cong \angle E$, and $\angle T \cong \angle D$. Therefore, the triangles are $\triangle RST \cong \triangle FED$.

Example B

If $\triangle CAT \cong \triangle DOG$, what else do you know?

From this congruence statement, we can conclude three pairs of angles and three pairs of sides are congruent.

$$\begin{array}{lll} \angle C \cong \angle D & \angle A \cong \angle O & \angle T \cong \angle G \\ \overline{CA} \cong \overline{DO} & \overline{AT} \cong \overline{OG} & \overline{CT} \cong \overline{DG} \end{array}$$

Example C

If $\triangle BUG \cong \triangle ANT$, what angle is congruent to $\angle N$?

Since the order of the letters in the congruence statement tells us which angles are congruent, $\angle N \cong \angle U$ because they are each the second of the three letters.

Watch this video for help with the Examples above.

MEDIA

Click image to the left for more content.

CK-12 Foundation: Chapter4CreatingCongruenceStatementsB

Concept Problem Revisited

 If $\triangle ABC \cong \triangle XYZ$, then $\overline{BA} \cong \overline{YX}$ and $\angle C \cong \angle Z$.

Vocabulary

 To be **congruent** means to be the same size and shape. Two triangles are **congruent** if their corresponding angles and sides are congruent. The symbol \cong means **congruent**.

Guided Practice

- If $\triangle ABC \cong \triangle DEF$, what else do you know?
- If $\triangle KBP \cong \triangle MRS$, what else do you know?
- If $\triangle EWN \cong \triangle MAP$, what else do you know?

Answers:

- From this congruence statement, we know three pairs of angles and three pairs of sides are congruent. $\angle A \cong \angle D$, $\angle B \cong \angle E$, $\angle C \cong \angle F$, $\overline{AB} \cong \overline{DE}$, $\overline{BC} \cong \overline{EF}$, $\overline{AC} \cong \overline{DF}$.
- From this congruence statement, we know three pairs of angles and three pairs of sides are congruent. $\angle K \cong \angle M$, $\angle B \cong \angle R$, $\angle P \cong \angle S$, $\overline{KB} \cong \overline{MR}$, $\overline{BP} \cong \overline{RS}$, $\overline{KP} \cong \overline{MS}$.
- From this congruence statement, we know three pairs of angles and three pairs of sides are congruent. $\angle E \cong \angle M$, $\angle W \cong \angle A$, $\angle N \cong \angle P$, $\overline{EW} \cong \overline{MA}$, $\overline{WN} \cong \overline{AP}$, $\overline{EN} \cong \overline{MP}$.

Practice

For questions 1-4, determine if the triangles are congruent using the definition of congruent triangles. If they are, write the congruence statement.

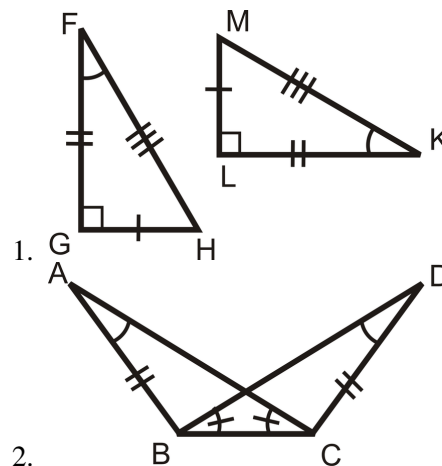

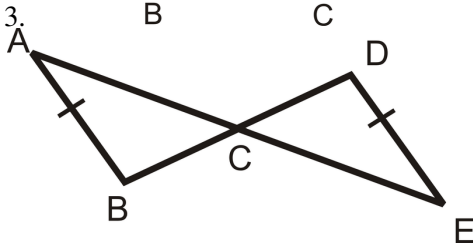
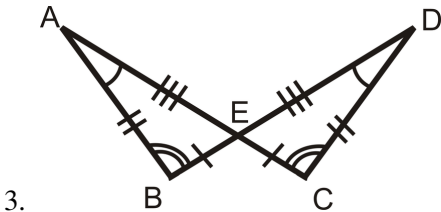

5. Suppose the two triangles to the right are congruent. Write a congruence statement for these triangles.

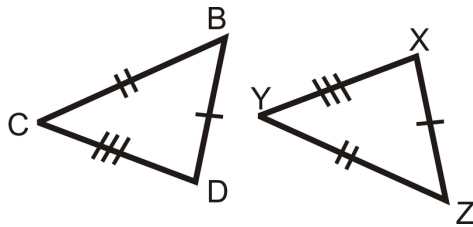

6. Explain how we know that if the two triangles are congruent, then $\angle B \cong \angle Z$.

Suppose $\triangle TBS \cong \triangle FAM$.

7. What angle is congruent to $\angle B$?
8. What side is congruent to \overline{FM} ?
9. What side is congruent to \overline{SB} ?

Suppose $\triangle INT \cong \triangle WEB$.

10. What side is congruent to \overline{IT} ?
11. What angle is congruent to $\angle W$?
12. What angle is congruent to $\angle I$?

Suppose $\triangle ADG \cong \triangle BCE$.

13. What side is congruent to \overline{CE} ?
14. What side is congruent to \overline{DA} ?
15. What angle is congruent to $\angle G$?

4.5 Third Angle Theorem

Here you'll learn the Third Angle Theorem and how to use it to determine information about two triangles with two pairs of angles that are congruent.

What if you were given $\triangle FGH$ and $\triangle XYZ$ and you were told that

$$\angle F \cong \angle X$$

and

$$\angle G \cong \angle Y$$

? What conclusion could you draw about $\angle H$ and $\angle Z$? After completing this Concept, you'll be able to make such a conclusion.

Watch This



MEDIA

Click image to the left for more content.

[CK-12 Foundation: Chapter4TheThirdAngleTheoremA](#)

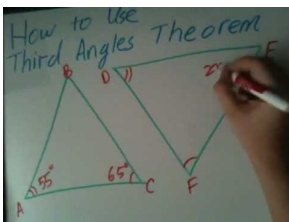

MEDIA

Click image to the left for more content.

Guidance

Find $m\angle C$ and $m\angle J$.

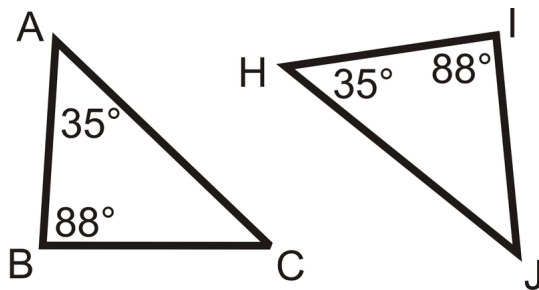

The sum of the angles in each triangle is 180° by the Triangle Sum Theorem. So, for $\triangle ABC$, $35^\circ + 88^\circ + m\angle C = 180^\circ$ and $m\angle C = 57^\circ$. For $\triangle HIJ$, $35^\circ + 88^\circ + m\angle J = 180^\circ$ and $m\angle J$ is also 57° .

Notice that we were given that $m\angle A = m\angle H$ and $m\angle B = m\angle I$ and we found out that $m\angle C = m\angle J$. This can be generalized into the Third Angle Theorem.

Third Angle Theorem: If two angles in one triangle are congruent to two angles in another triangle, then the third pair of angles must also be congruent.

In other words, for triangles $\triangle ABC$ and $\triangle DEF$, if $\angle A \cong \angle D$ and $\angle B \cong \angle E$, then $\angle C \cong \angle F$.

Notice that this theorem does not state that the triangles are congruent. That is because if two sets of angles are congruent, the sides could be different lengths. See the picture below.

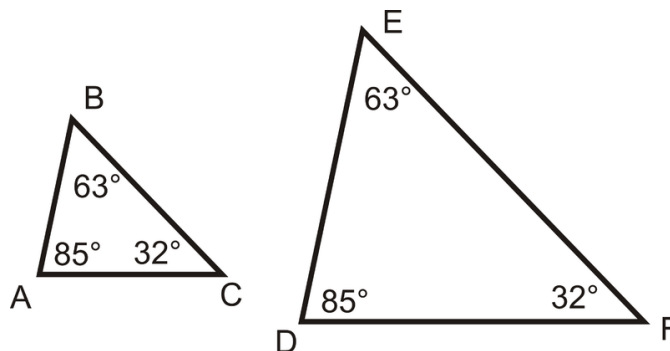

Example A

Determine the measure of the missing angles.

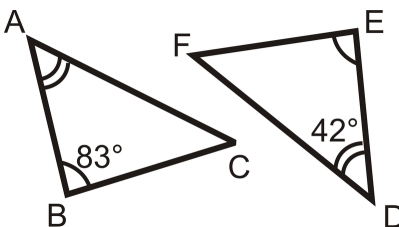

From the markings, we know that $\angle A \cong \angle E$ and $\angle B \cong \angle D$. Therefore, the Third Angle Theorem tells us that $\angle C \cong \angle F$. So,

$$m\angle A + m\angle B + m\angle C = 180^\circ$$

$$m\angle D + m\angle B + m\angle C = 180^\circ$$

$$42^\circ + 83^\circ + m\angle C = 180^\circ$$

$$m\angle C = 55^\circ = m\angle F$$

Example B

The Third Angle Theorem states that if two angles in one triangle are congruent to two angles in another triangle, then the third pair of angles must also be congruent. What additional information would you need to know in order to be able to determine that the triangles are congruent?

In order for the triangles to be congruent, you need some information about the sides. If you know two pairs of angles are congruent and at least one pair of corresponding sides are congruent, then the triangles will be congruent.

Example C

Determine the measure of all the angles in the triangle:

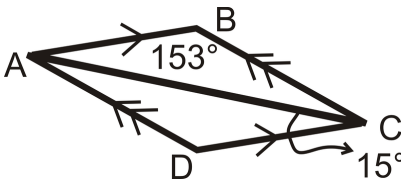

First we can see that $m\angle DCA = 15^\circ$. This means that $m\angle BAC = 15^\circ$ also because they are alternate interior angles. $m\angle ABC = 153^\circ$ was given. This means by the Triangle Sum Theorem that $m\angle BCA = 12^\circ$. This means that $m\angle CAD = 12^\circ$ also because they are alternate interior angles. Finally, $m\angle ADC = 153^\circ$ by the Triangle Sum Theorem.

Watch this video for help with the Examples above.



MEDIA
Click image to the left for more content.

[CK-12 Foundation: Chapter4TheThirdAngleTheoremB](#)

Concept Problem Revisited

For two given triangles $\triangle FGH$ and $\triangle XYZ$, you were told that $\angle F \cong \angle X$ and $\angle G \cong \angle Y$.

By the Third Angle Theorem, $\angle H \cong \angle Z$.

Vocabulary

Two figures are **congruent** if they have exactly the same size and shape. Two triangles are **congruent** if the three corresponding angles and sides are congruent. The **Triangle Sum Theorem** states that the measure of the three interior angles of any triangle will add up to 180° . The **Third Angle Theorem** states that if two angles in one triangle are congruent to two angles in another triangle, then the third pair of angles must also be congruent.

Guided Practice

Determine the measure of all the angles in the each triangle.

1.

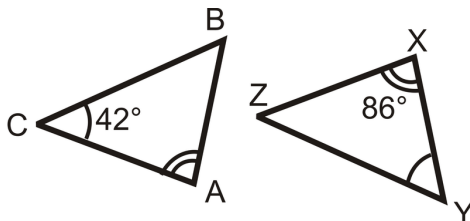

2.

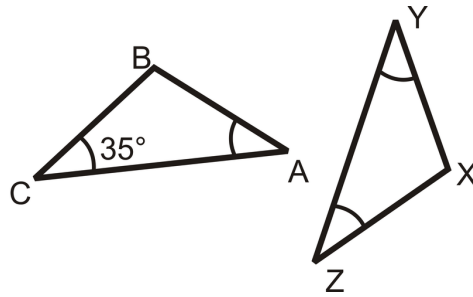

3.

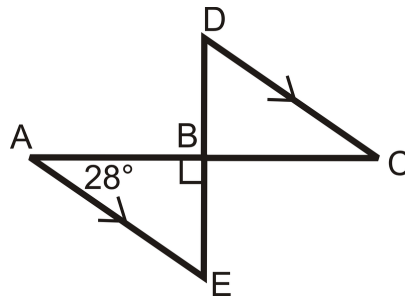
**Answers:**

1. $m\angle A = 86$, $m\angle C = 42$ and by the Triangle Sum Theorem $m\angle B = 52$.

$m\angle Y = 42$, $m\angle X = 86$ and by the Triangle Sum Theorem, $m\angle Z = 52$.

2. $m\angle C = m\angle A = m\angle Y = m\angle Z = 35$. By the Triangle Sum Theorem $m\angle B = m\angle X = 110$.

3. $m\angle A = 28$, $m\angle ABE = 90$ and by the Triangle Sum Theorem, $m\angle E = 62$. $m\angle D = m\angle E = 62$ because they are alternate interior angles and the lines are parallel. $m\angle C = m\angle A = 28$ because they are alternate interior angles and the lines are parallel. $m\angle DBC = m\angle ABE = 90$ because they are vertical angles.

Practice

Determine the measures of the unknown angles.

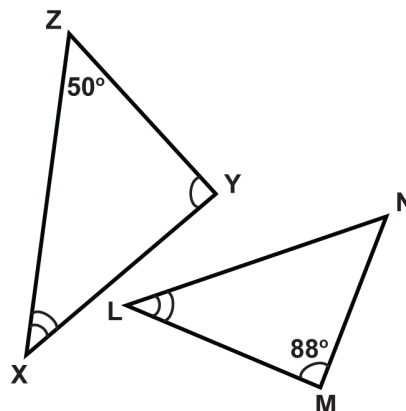

1. $\angle XYZ$
2. $\angle ZXY$

3. $\angle LNM$
4. $\angle MLN$

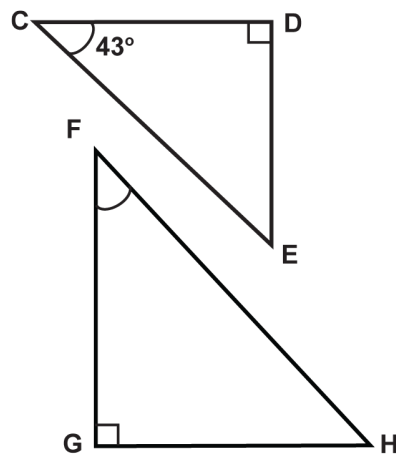

5. $\angle CED$
6. $\angle GFH$
7. $\angle FHG$

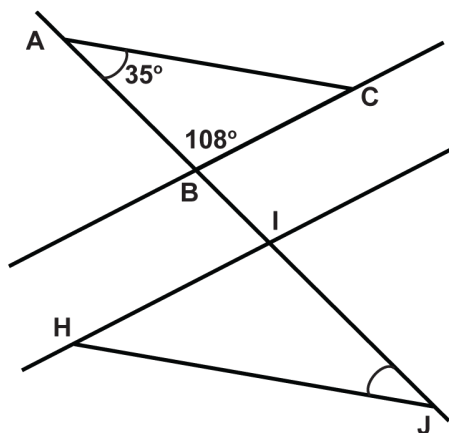

8. $\angle ACB$
9. $\angle HIJ$
10. $\angle HJI$
11. $\angle IHJ$

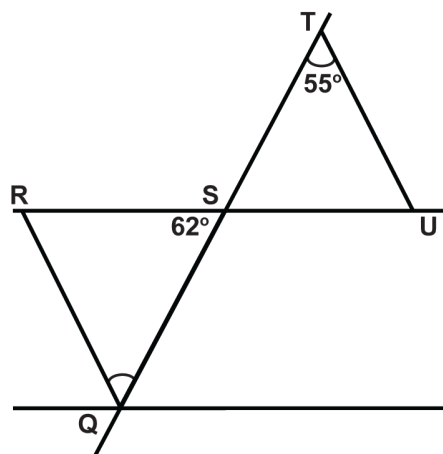

12. $\angle RQS$
13. $\angle SRQ$
14. $\angle TSU$
15. $\angle TUS$

4.6 SSS Triangle Congruence

Here you'll learn how to prove that two triangles are congruent given only information about the side lengths of the triangles.

What if your parents were remodeling their kitchen so that measurements between the sink, refrigerator, and oven were as close to an equilateral triangle as possible? The measurements are in the picture at the left, below. Your neighbor's kitchen has the measurements on the right, below. Are the two triangles congruent? After completing this Concept, you'll be able to determine whether or not two triangles are congruent given only their side lengths.

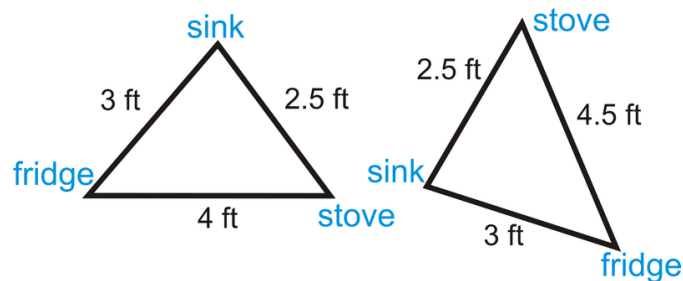

Watch This



MEDIA

Click image to the left for more content.

CK-12 Foundation: Chapter4SSSTriangleCongruenceA

Watch the portions of the following two videos that deal with SSS triangle congruence.

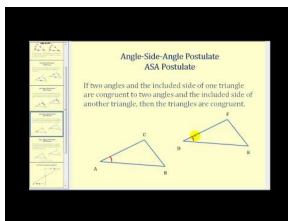

MEDIA

Click image to the left for more content.

James Sousa:Introduction toCongruent Triangles

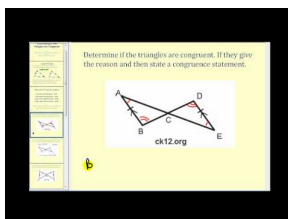

MEDIA

Click image to the left for more content.

James Sousa: Determining If Two Triangles are Congruent

Guidance

Consider the question: If I have three lengths, 3 in, 4 in, and 5 in, can I construct more than one triangle with these measurements? In other words, can I construct two different triangles with these same three lengths?

Investigation: Constructing a Triangle Given Three Sides

Tools Needed: compass, pencil, ruler, and paper

1. Draw the longest side (5 in) horizontally, halfway down the page. *The drawings in this investigation are to scale.*



2. Take the compass and, using the ruler, widen the compass to measure 4 in, the next side.

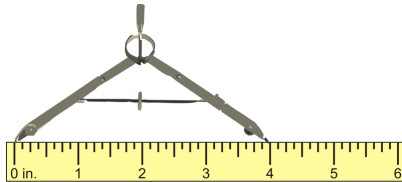

3. Using the measurement from Step 2, place the pointer of the compass on the left endpoint of the side drawn in Step 1. Draw an arc mark above the line segment.

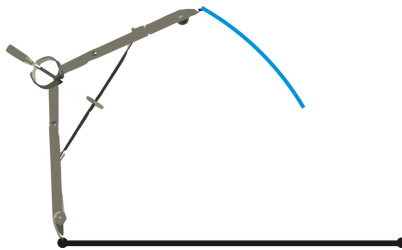

4. Repeat Step 2 with the last measurement, 3 in. Then, place the pointer of the compass on the right endpoint of the side drawn in Step 1. Draw an arc mark above the line segment. Make sure it intersects the arc mark drawn in Step 3.

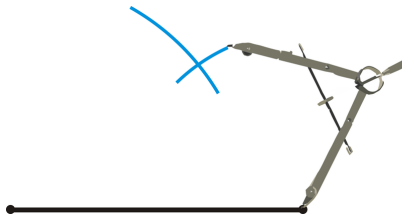

5. Draw lines from each endpoint to the arc intersections. These lines will be the other two sides of the triangle.

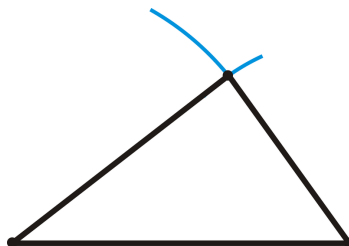

Can you draw another triangle, with these measurements that looks different? The answer is NO. Only one triangle can be created from any given three lengths.

An animation of this investigation can be found at: <http://www.mathsisfun.com/geometry/construct-ruler-compass-1.html>

Side-Side-Side (SSS) Triangle Congruence Postulate: If three sides in one triangle are congruent to three sides in another triangle, then the triangles are congruent.

Now, we only need to show that all three sides in a triangle are congruent to the three sides in another triangle. This is a postulate so we accept it as true without proof. Think of the SSS Postulate as a shortcut. You no longer have to show 3 sets of angles are congruent and 3 sets of sides are congruent in order to say that the two triangles are congruent.

In the coordinate plane, the easiest way to show two triangles are congruent is to find the lengths of the 3 sides in each triangle. Finding the measure of an angle in the coordinate plane can be a little tricky, so we will avoid it in this text. Therefore, you will only need to apply SSS in the coordinate plane. To find the lengths of the sides, you will need to use the distance formula, $\sqrt{(x_2 - x_1)^2 + (y_2 - y_1)^2}$.

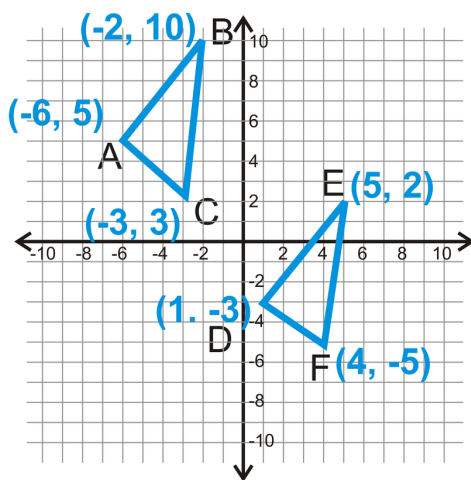

Example A

Write a triangle congruence statement based on the diagram below:

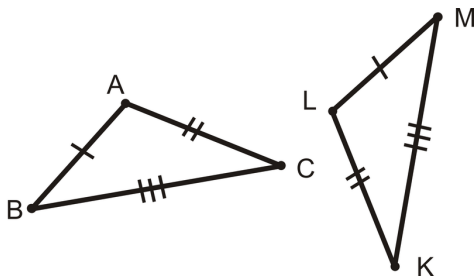

From the tic marks, we know $\overline{AB} \cong \overline{LM}$, $\overline{AC} \cong \overline{LK}$, $\overline{BC} \cong \overline{MK}$. Using the SSS Postulate we know the two triangles are congruent. Lining up the corresponding sides, we have $\triangle ABC \cong \triangle LMK$.

Don't forget ORDER MATTERS when writing triangle congruence statements. Here, we lined up the sides with one tic mark, then the sides with two tic marks, and finally the sides with three tic marks.

Example B

Write a two-column proof to show that the two triangles are congruent.

Given: $\overline{AB} \cong \overline{DE}$

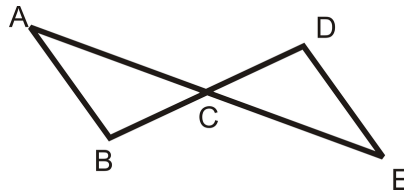

C is the midpoint of \overline{AE} and \overline{DB} .

Prove: $\triangle ACB \cong \triangle ECD$

TABLE 4.3:

Statement

1. $\overline{AB} \cong \overline{DE}$

C is the midpoint of \overline{AE} and \overline{DB}

2. $\overline{AC} \cong \overline{CE}$, $\overline{BC} \cong \overline{CD}$

3. $\triangle ACB \cong \triangle ECD$

Reason

Given

Definition of a midpoint

SSS Postulate

Make sure that you clearly state the three sets of congruent sides BEFORE stating that the triangles are congruent.

Prove Move: Feel free to mark the picture with the information you are given as well as information that you can infer (vertical angles, information from parallel lines, midpoints, angle bisectors, right angles).

Example C

Find the distances of all the line segments from both triangles to see if the two triangles are congruent.

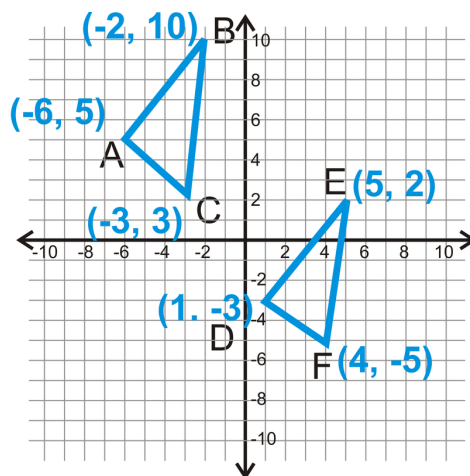

Begin with $\triangle ABC$ and its sides.

$$\begin{aligned}
 AB &= \sqrt{(-6 - (-2))^2 + (5 - 10)^2} \\
 &= \sqrt{(-4)^2 + (-5)^2} \\
 &= \sqrt{16 + 25} \\
 &= \sqrt{41}
 \end{aligned}$$

$$\begin{aligned}
 BC &= \sqrt{(-2 - (-3))^2 + (10 - 3)^2} \\
 &= \sqrt{(1)^2 + (7)^2} \\
 &= \sqrt{1 + 49} \\
 &= \sqrt{50} = 5\sqrt{2}
 \end{aligned}$$

$$\begin{aligned}
 AC &= \sqrt{(-6 - (-3))^2 + (5 - 3)^2} \\
 &= \sqrt{(-3)^2 + (2)^2} \\
 &= \sqrt{9 + 4} \\
 &= \sqrt{13}
 \end{aligned}$$

Now, find the distances of all the sides in $\triangle DEF$.

$$\begin{aligned}
 DE &= \sqrt{(1 - 5)^2 + (-3 - 2)^2} \\
 &= \sqrt{(-4)^2 + (-5)^2} \\
 &= \sqrt{16 + 25} \\
 &= \sqrt{41}
 \end{aligned}$$

$$\begin{aligned}
 EF &= \sqrt{(5 - 4)^2 + (2 - (-5))^2} \\
 &= \sqrt{(1)^2 + (7)^2} \\
 &= \sqrt{1 + 49} \\
 &= \sqrt{50} = 5\sqrt{2}
 \end{aligned}$$

$$\begin{aligned}
 DF &= \sqrt{(1 - 4)^2 + (-3 - (-5))^2} \\
 &= \sqrt{(-3)^2 + (2)^2} \\
 &= \sqrt{9 + 4} \\
 &= \sqrt{13}
 \end{aligned}$$

We see that $AB = DE$, $BC = EF$, and $AC = DF$. Recall that if two lengths are equal, then they are also congruent. Therefore, $\overline{AB} \cong \overline{DE}$, $\overline{BC} \cong \overline{EF}$, and $\overline{AC} \cong \overline{DF}$. Because the corresponding sides are congruent, we can say that $\triangle ABC \cong \triangle DEF$ by SSS.

Watch this video for help with the Examples above.



MEDIA

Click image to the left for more content.

CK-12 Foundation: Chapter4SSSTriangleCongruenceB

Concept Problem Revisited

From what we have learned in this section, the two triangles are not congruent because the distance from the fridge to the stove in your house is 4 feet and in your neighbor's it is 4.5 ft. The SSS Postulate tells us that all three sides have to be congruent.

Vocabulary

Two figures are **congruent** if they have exactly the same size and shape. By definition, two triangles are **congruent** if the three corresponding angles and sides are congruent. The symbol \cong means congruent. There are shortcuts for proving that triangles are congruent. The **SSS Triangle Congruence Postulate** states that if three sides in one triangle are congruent to three sides in another triangle, then the triangles are congruent.

Guided Practice

- Determine if the two triangles are congruent.

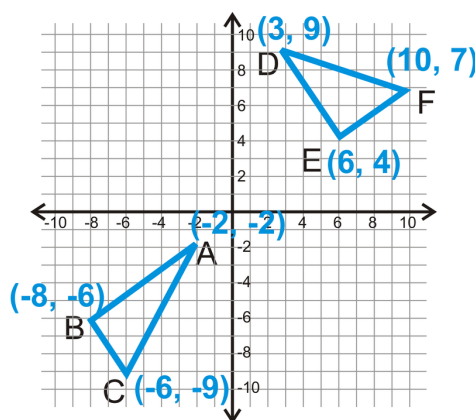

- Fill in the blanks in the proof below.

Given: $\overline{AB} \cong \overline{DC}$, $\overline{AC} \cong \overline{DB}$

Prove: $\triangle ABC \cong \triangle DCB$

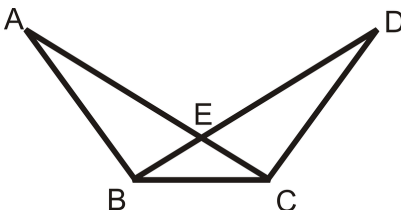
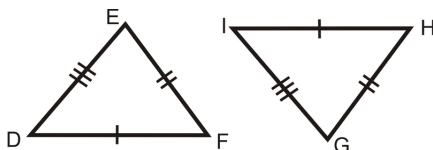

TABLE 4.4:

| <i>Statement</i> | <i>Reason</i> |
|--|------------------|
| 1. | 1. |
| 2. | 2. Reflexive PoC |
| 3. $\triangle ABC \cong \triangle DCB$ | 3. |

3. Is the pair of triangles congruent? If so, write the congruence statement and why.

**Answers:**

1. Start with $\triangle ABC$.

$$\begin{aligned}
 AB &= \sqrt{(-2 - (-8))^2 + (-2 - (-6))^2} \\
 &= \sqrt{(6)^2 + (4)^2} \\
 &= \sqrt{36 + 16} \\
 &= \sqrt{52} = 2\sqrt{13}
 \end{aligned}$$

$$\begin{aligned}
 BC &= \sqrt{(-8 - (-6))^2 + (-6 - (-9))^2} \\
 &= \sqrt{(-2)^2 + (3)^2} \\
 &= \sqrt{4 + 9} \\
 &= \sqrt{13}
 \end{aligned}$$

$$\begin{aligned}
 AC &= \sqrt{(-2 - (-6))^2 + (-2 - (-9))^2} \\
 &= \sqrt{(4)^2 + (7)^2} \\
 &= \sqrt{16 + 49} \\
 &= \sqrt{65}
 \end{aligned}$$

Now find the sides of $\triangle DEF$.

$$\begin{aligned}
 DE &= \sqrt{(3-6)^2 + (9-4)^2} \\
 &= \sqrt{(-3)^2 + (5)^2} \\
 &= \sqrt{9+25} \\
 &= \sqrt{34}
 \end{aligned}$$

$$\begin{aligned}
 EF &= \sqrt{(6-10)^2 + (4-7)^2} \\
 &= \sqrt{(-4)^2 + (-3)^2} \\
 &= \sqrt{16+9} \\
 &= \sqrt{25} = 5
 \end{aligned}$$

$$\begin{aligned}
 DF &= \sqrt{(3-10)^2 + (9-7)^2} \\
 &= \sqrt{(-7)^2 + (2)^2} \\
 &= \sqrt{49+4} \\
 &= \sqrt{53}
 \end{aligned}$$

No sides have equal measures, so the triangles are not congruent.

2.

TABLE 4.5:

| <i>Statement</i> | <i>Reason</i> |
|--|------------------|
| 1. $\overline{AB} \cong \overline{DC}$, $\overline{AC} \cong \overline{DB}$ | 1. Given |
| 2. $\overline{BC} \cong \overline{CB}$ | 2. Reflexive PoC |
| 3. $\triangle ABC \cong \triangle DCB$ | 3. SSS Postulate |

3. The triangles are congruent because they have three pairs of sides congruent. $\triangle DEF \cong \triangle IGH$.

Practice

Are the pairs of triangles congruent? If so, write the congruence statement and why.

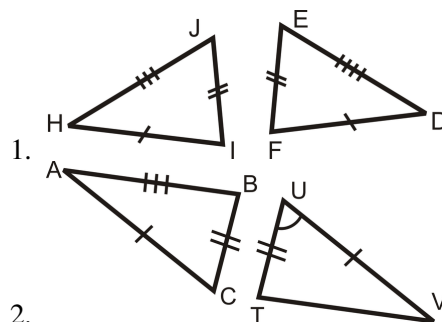

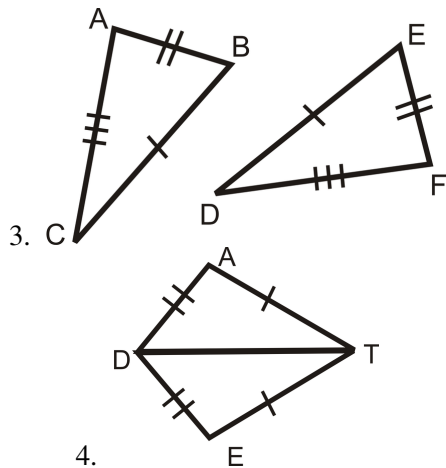

State the additional piece of information needed to show that each pair of triangles is congruent.

5. Use SSS

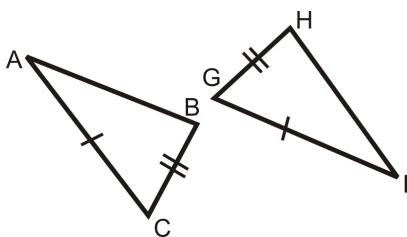

6. Use SSS

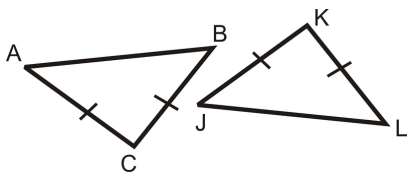

Fill in the blanks in the proofs below.

7. Given: B is the midpoint of \overline{DC} Prove: $\triangle ABD \cong \triangle ABC$

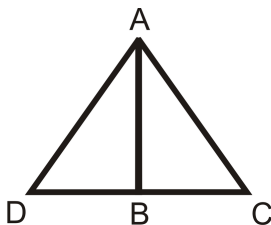

TABLE 4.6:

Statement

- 1.
- 2.
- 3.
4. $\triangle ABD \cong \triangle ABC$

Reason

- 1.
2. Definition of a Midpoint
3. Reflexive PoC
- 4.

Find the lengths of the sides of each triangle to see if the two triangles are congruent.

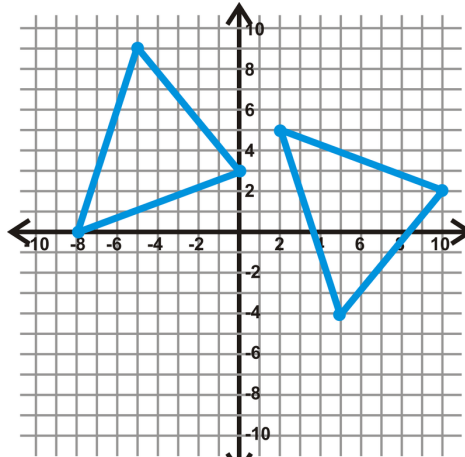

8.

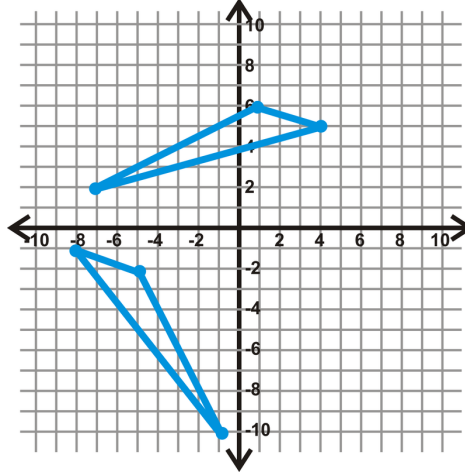

9.

10. $\triangle ABC$: $A(-1,5)$, $B(-4,2)$, $C(2,-2)$ and $\triangle DEF$: $D(7,-5)$, $E(4,2)$, $F(8,-9)$
11. $\triangle ABC$: $A(-8,-3)$, $B(-2,-4)$, $C(-5,-9)$ and $\triangle DEF$: $D(-7,2)$, $E(-1,3)$, $F(-4,8)$
12. $\triangle ABC$: $A(0,5)$, $B(3,2)$, $C(1,4)$ and $\triangle DEF$: $D(1,2)$, $E(4,4)$, $F(7,1)$
13. $\triangle ABC$: $A(1,7)$, $B(2,2)$, $C(4,6)$ and $\triangle DEF$: $D(4,10)$, $E(5,5)$, $F(7,9)$
14. Draw an example to show why SS is not enough to prove that two triangles are congruent.
15. If you know that two triangles are similar, how many pairs of corresponding sides do you need to know are congruent in order to know that the triangles are congruent?

4.7 SAS Triangle Congruence

Here you'll learn how to prove that two triangles are congruent given only information about two pairs of sides and included angles.

What if you were given two triangles and provided with only two of their side lengths and the measure of the angle between those two sides? How could you determine if the two triangles were congruent? After completing this Concept, you'll be able to use the Side-Angle-Side (SAS) shortcut to prove triangles are congruent.

Watch This



MEDIA

Click image to the left for more content.

[CK-12 Foundation: Chapter4SASTriangleCongruenceA](#)

Watch the portions of the following two videos that deal with SAS triangle congruence.

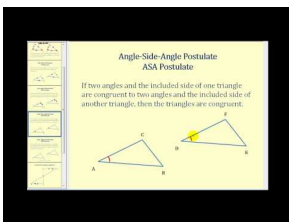

MEDIA

Click image to the left for more content.

[James Sousa:Introduction toCongruent Triangles](#)

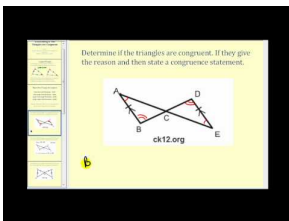

MEDIA

Click image to the left for more content.

[James Sousa:DeterminingIf Two Triangles are Congruent](#)

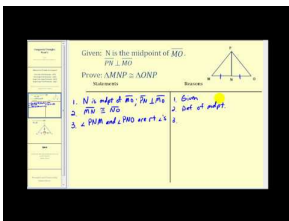

MEDIA

Click image to the left for more content.

James Sousa:Example1: Prove Two Triangles are Congruent

Guidance

An **included angle** is when an angle is between two given sides of a triangle (or polygon). In the picture below, the markings indicate that \overline{AB} and \overline{BC} are the given sides, so $\angle B$ would be the included angle.

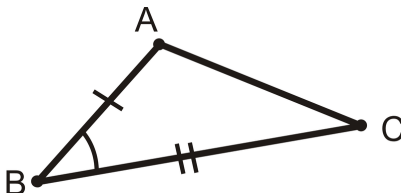

Consider the question: If I have two sides of length 2 in and 5 in and the angle between them is 45° , can I construct only one triangle?

Investigation: Constructing a Triangle Given Two Sides and Included Angle

Tools Needed: protractor, pencil, ruler, and paper

1. Draw the longest side (5 in) horizontally, halfway down the page. *The drawings in this investigation are to scale.*



2. At the left endpoint of your line segment, use the protractor to measure a 45° angle. Mark this measurement.

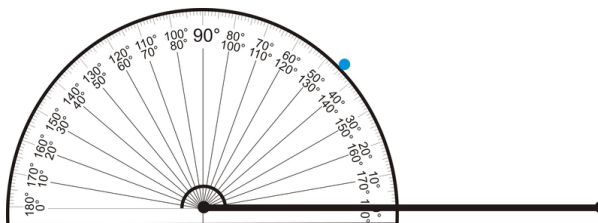

3. Connect your mark from Step 2 with the left endpoint. Make your line 2 in long, the length of the second side.



4. Connect the two endpoints by drawing the third side.



Can you draw another triangle, with these measurements that looks different? The answer is NO. Only one triangle can be created from any given two lengths and the INCLUDED angle.

Side-Angle-Side (SAS) Triangle Congruence Postulate: If two sides and the included angle in one triangle are congruent to two sides and the included angle in another triangle, then the two triangles are congruent.

The markings in the picture are enough to say that $\triangle ABC \cong \triangle XYZ$.

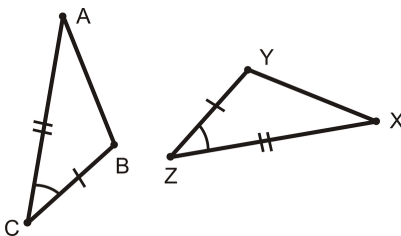

Example A

What additional piece of information would you need to prove that these two triangles are congruent using the SAS Postulate?

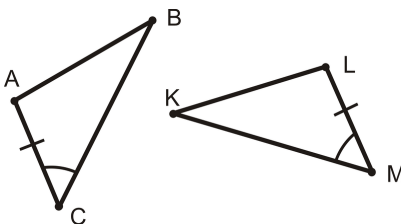

- a) $\angle ABC \cong \angle LKM$
- b) $\overline{AB} \cong \overline{LK}$
- c) $\overline{BC} \cong \overline{KM}$
- d) $\angle BAC \cong \angle KLM$

For the SAS Postulate, you need two sides and the included angle in both triangles. So, you need the side on the other side of the angle. In $\triangle ABC$, that is \overline{BC} and in $\triangle LKM$ that is \overline{KM} . The correct answer is c.

Example B

Write a two-column proof to show that the two triangles are congruent.

Given: C is the midpoint of \overline{AE} and \overline{DB}

Prove: $\triangle ACB \cong \triangle ECD$

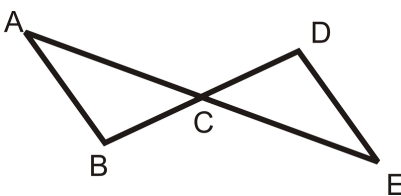
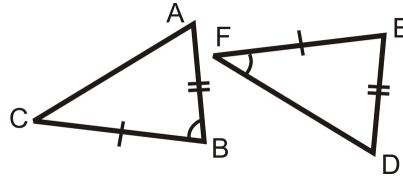

TABLE 4.7:

| <i>Statement</i> | <i>Reason</i> |
|---|---------------------------|
| 1. C is the midpoint of \overline{AE} and \overline{DB} | Given |
| 2. $\overline{AC} \cong \overline{CE}, \overline{BC} \cong \overline{CD}$ | Definition of a midpoint |
| 3. $\angle ACB \cong \angle DCE$ | Vertical Angles Postulate |
| 4. $\triangle ACB \cong \triangle ECD$ | SAS Postulate |

Example C

Is the pair of triangles congruent? If so, write the congruence statement and why.



While the triangles have two pairs of sides and one pair of angles that are congruent, the angle is not in the same place in both triangles. The first triangle fits with SAS, but the second triangle is SSA. There is not enough information for us to know whether or not these triangles are congruent.

Watch this video for help with the Examples above.

**MEDIA**

Click image to the left for more content.

[CK-12 Foundation: Chapter4SASTriangleCongruenceB](#)

Vocabulary

Two figures are **congruent** if they have exactly the same size and shape. By definition, two triangles are **congruent** if the three corresponding angles and sides are congruent. The symbol \cong means congruent. There are shortcuts for proving that triangles are congruent. The **SAS Triangle Postulate** states that if two sides and the included angle in one triangle are congruent to two sides and the included angle in another triangle, then the two triangles are congruent.

Guided Practice

1. Is the pair of triangles congruent? If so, write the congruence statement and why.

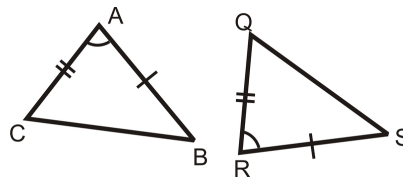

2. State the additional piece of information needed to show that each pair of triangles is congruent.

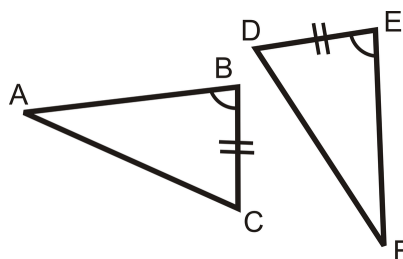

3. Fill in the blanks in the proof below.

Given:

$$\overline{AB} \cong \overline{DC}, \overline{BE} \cong \overline{CE}$$

Prove: $\triangle ABE \cong \triangle ACE$

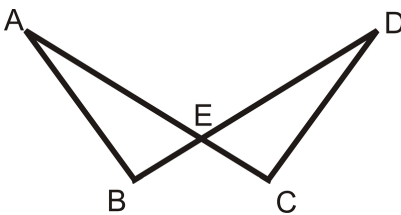

TABLE 4.8:

| <i>Statement</i> | <i>Reason</i> |
|--|---------------|
| 1. | 1. |
| 2. $\angle AEB \cong \angle DEC$ | 2. |
| 3. $\triangle ABE \cong \triangle ACE$ | 3. |

Answers:

- The pair of triangles is congruent by the SAS postulate. $\triangle CAB \cong \triangle QRS$.
- We know that one pair of sides and one pair of angles are congruent from the diagram. In order to know that the triangles are congruent by SAS we need to know that the pair of sides on the other side of the angle are congruent. So, we need to know that $\overline{EF} \cong \overline{BA}$.
-

TABLE 4.9:

| <i>Statement</i> | <i>Reason</i> |
|---|---------------------------|
| 1. $\overline{AB} \cong \overline{DC}, \overline{BE} \cong \overline{CE}$ | 1. Given |
| 2. $\angle AEB \cong \angle DEC$ | 2. Vertical Angle Theorem |
| 3. $\triangle ABE \cong \triangle ACE$ | 3. SAS postulate |

Practice

Are the pairs of triangles congruent? If so, write the congruence statement and why.

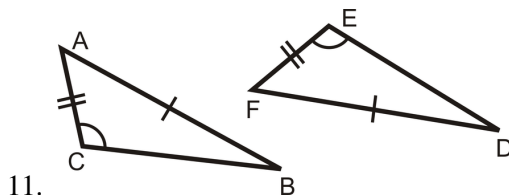

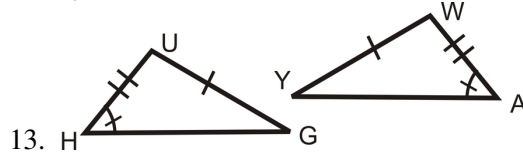
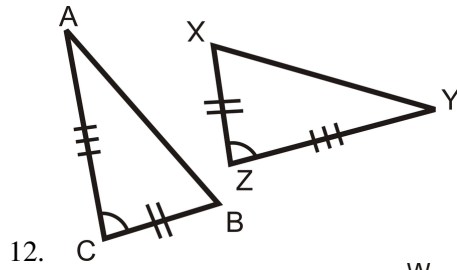

State the additional piece of information needed to show that each pair of triangles is congruent.

4. Use SAS

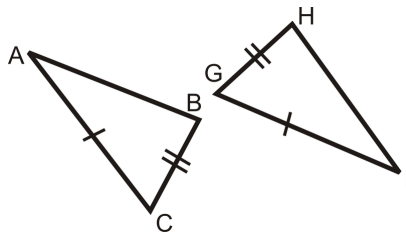

5. Use SAS

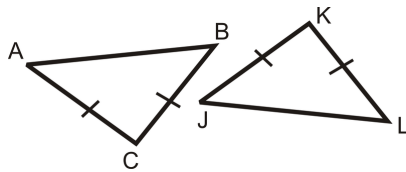

6. Use SAS

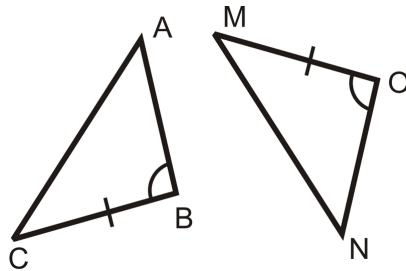

Complete the proofs below.

7. Given: B is a midpoint of \overline{DC} $\perp \overline{AB}$ Prove: $\triangle ABD \cong \triangle ABC$

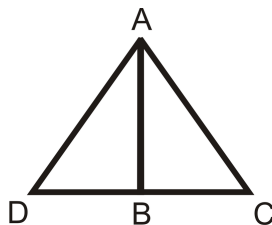

8. Given: \overline{AB} is an angle bisector of $\angle DAC$ $\overline{AD} \cong \overline{AC}$ Prove: $\triangle ABD \cong \triangle ABC$

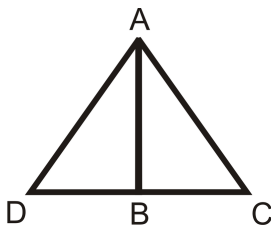

9. Given: B is the midpoint of \overline{DE} and $\overline{AC} \perp \overline{ABE}$ is a right angle Prove: $\triangle ABE \cong \triangle CBD$

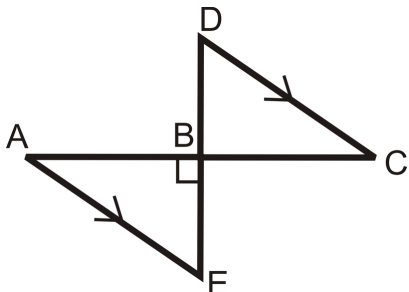

10. Given: \overline{DB} is the angle bisector of $\angle ADC$ $\overline{AD} \cong \overline{DC}$ Prove: $\triangle ABD \cong \triangle CBD$

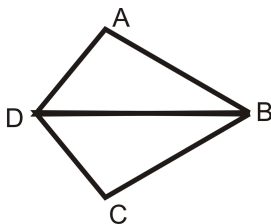

For each pair of triangles, write what needs to be congruent in order for the triangles to be congruent by SAS. Then, write the congruence statement for the triangles.

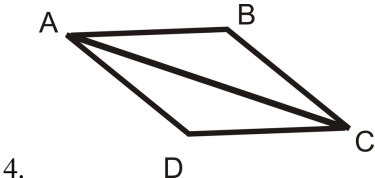
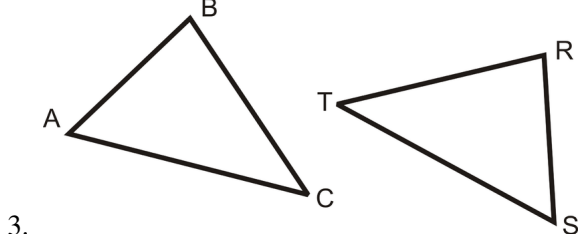
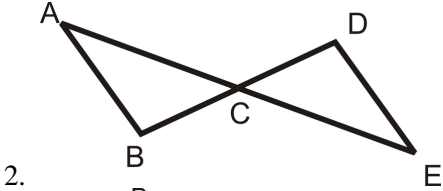
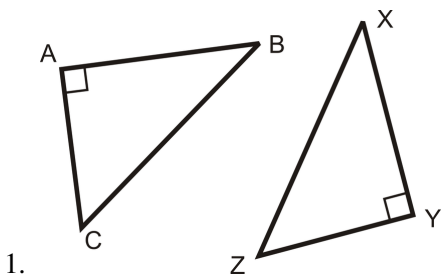

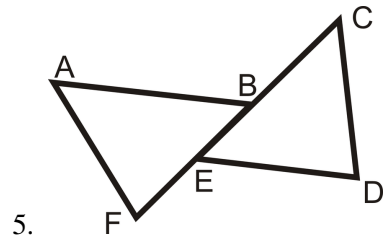

4.8 ASA and AAS Triangle Congruence

Here you'll learn how to prove that two triangles are congruent given only information about two pairs of angles and a pair of sides.

What if your parents changed their minds at the last second about their kitchen layout? Now, they have decided they to have the distance between the sink and the fridge be 3 ft, the angle at the sink 71° and the angle at the fridge is 50° . You used your protractor to measure the angle at the stove and sink at your neighbor's house. Are the kitchen triangles congruent now? After completing this Concept, you'll be able to use a congruence shortcut to help you answer this question.

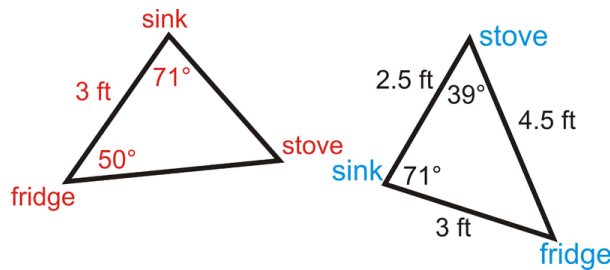

Watch This



MEDIA

Click image to the left for more content.

CK-12 Foundation: Chapter4ASAandAASTriangleCongruenceA

Watch the portions of the following two videos that deal with ASA and AAS triangle congruence.

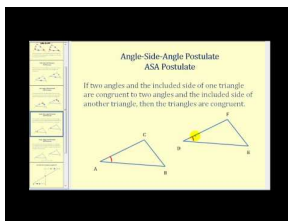

MEDIA

Click image to the left for more content.

James Sousa:Introduction toCongruent Triangles

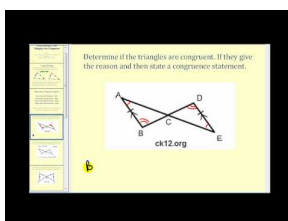

MEDIA

Click image to the left for more content.

James Sousa: Determining If Two Triangles are Congruent

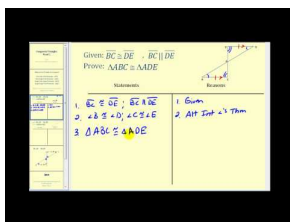

MEDIA

Click image to the left for more content.

James Sousa: Example 2: Prove Two Triangles are Congruent

Guidance

Consider the question: If I have two angles that are 45° and 60° and the side between them is 5 in, can I construct only one triangle? We will investigate it here.

Investigation: Constructing a Triangle Given Two Angles and Included Side

Tools Needed: protractor, pencil, ruler, and paper

1. Draw the side (5 in) horizontally, halfway down the page. *The drawings in this investigation are to scale.*



2. At the left endpoint of your line segment, use the protractor to measure the 45° angle. Mark this measurement and draw a ray from the left endpoint through the 45° mark.

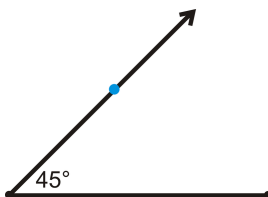

3. At the right endpoint of your line segment, use the protractor to measure the 60° angle. Mark this measurement and draw a ray from the right endpoint through the 60° mark. Extend this ray so that it crosses through the ray from Step 2.

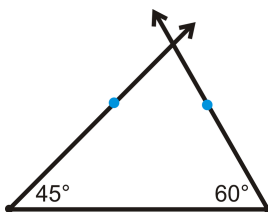

4. Erase the extra parts of the rays from Steps 2 and 3 to leave only the triangle.

Can you draw another triangle, with these measurements that looks different? The answer is NO. Only one triangle can be created from any given two angle measures and the INCLUDED side.

Angle-Side-Angle (ASA) Triangle Congruence Postulate: If two angles and the included side in one triangle are congruent to two angles and the included side in another triangle, then the two triangles are congruent.

The markings in the picture are enough to say $\triangle ABC \cong \triangle XYZ$.

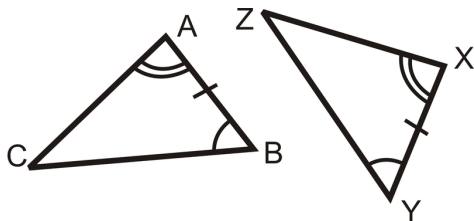

A variation on ASA is AAS, which is Angle-Angle-Side. Recall that for ASA you need two angles and the side between them. But, if you know two pairs of angles are congruent, then the third pair will also be congruent by the Third Angle Theorem. Therefore, you can prove a triangle is congruent whenever you have any two angles and a side.

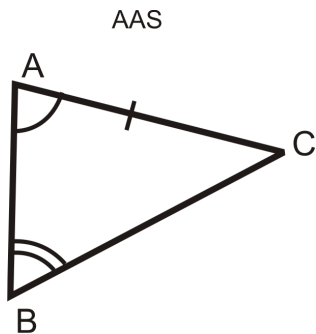
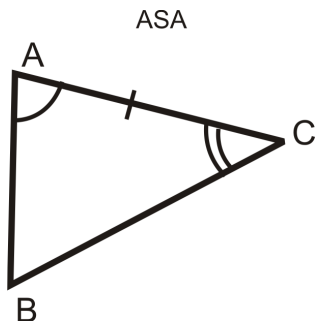

Be careful to note the placement of the side for ASA and AAS. As shown in the pictures above, the side is *between* the two angles for ASA and it is not for AAS.

Angle-Angle-Side (AAS or SAA) Triangle Congruence Theorem: If two angles and a non-included side in one triangle are congruent to two corresponding angles and a non-included side in another triangle, then the triangles are congruent.

Proof of AAS Theorem:

Given: $\angle A \cong \angle Y$, $\angle B \cong \angle Z$, $\overline{AC} \cong \overline{XY}$

Prove: $\triangle ABC \cong \triangle YZX$

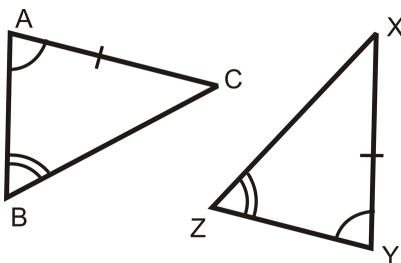
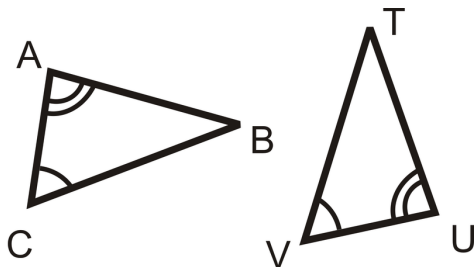

TABLE 4.10:

| <i>Statement</i> | <i>Reason</i> |
|--|---------------------|
| 1. $\angle A \cong \angle Y, \angle B \cong \angle Z, \overline{AC} \cong \overline{XY}$ | Given |
| 2. $\angle C \cong \angle X$ | Third Angle Theorem |
| 3. $\triangle ABC \cong \triangle YZX$ | ASA |

Example A

What information would you need to prove that these two triangles are congruent using the ASA Postulate?



- a) $\overline{AB} \cong \overline{UT}$
- b) $\overline{AC} \cong \overline{UV}$
- c) $\overline{BC} \cong \overline{TV}$
- d) $\angle B \cong \angle T$

For ASA, we need the side between the two given angles, which is \overline{AC} and \overline{UV} . The answer is b.

Example B

Write a two-column proof.

Given: $\angle C \cong \angle E, \overline{AC} \cong \overline{AE}$

Prove: $\triangle ACF \cong \triangle AEB$

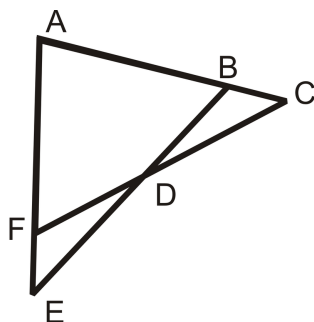

TABLE 4.11:

| <i>Statement</i> | <i>Reason</i> |
|---|---------------|
| 1. $\angle C \cong \angle E, \overline{AC} \cong \overline{AE}$ | Given |
| 2. $\angle A \cong \angle A$ | Reflexive PoC |
| 3. $\triangle ACF \cong \triangle AEB$ | ASA |

Example C

What information do you need to prove that these two triangles are congruent using:

- a) ASA?
- b) AAS?

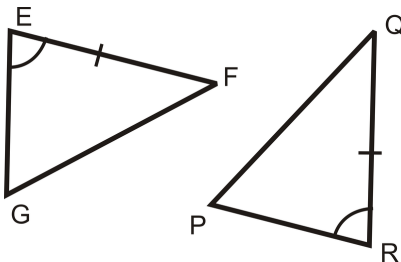

a) For ASA, we need the angles on the other side of \overline{EF} and \overline{QR} . Therefore, we would need $\angle F \cong \angle Q$.

b) For AAS, we would need the angle on the other side of $\angle E$ and $\angle R$. $\angle G \cong \angle P$.

Watch this video for help with the Examples above.

**MEDIA**

Click image to the left for more content.

[CK-12 Foundation: Chapter4ASAandAASTriangleCongruenceB](#)

Concept Problem Revisited

Even though we do not know all of the angle measures in the two kitchens, we can find the missing angles by using the Third Angle Theorem. In your parents' kitchen, the missing angle is 39° . The missing angle in your neighbor's kitchen is 50° . From this, we can conclude that the two kitchens are now congruent, either by ASA or AAS.

Vocabulary

Two figures are **congruent** if they have exactly the same size and shape. By definition, two triangles are **congruent** if the three corresponding angles and sides are congruent. The symbol \cong means congruent. There are shortcuts for proving that triangles are congruent. The **ASA Triangle Congruence Postulate** states that if two angles and the included side in one triangle are congruent to two angles and the included side in another triangle, then the two triangles are congruent. The **AAS Triangle Congruence Theorem** states that if two angles and a non-included side in one triangle are congruent to two corresponding angles and a non-included side in another triangle, then the triangles are congruent. **CPCTC** refers to **Corresponding Parts of Congruent Triangles are Congruent**. It is used to show two sides or two angles in triangles are congruent after having proved that the triangles are congruent.

Guided Practice

1. Can you prove that the following triangles are congruent? Why or why not?

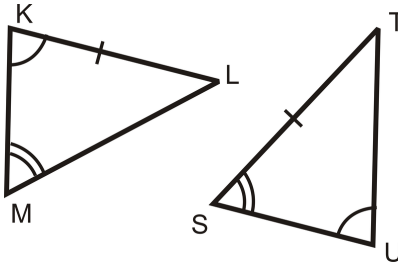

2. Write a 2-column proof.

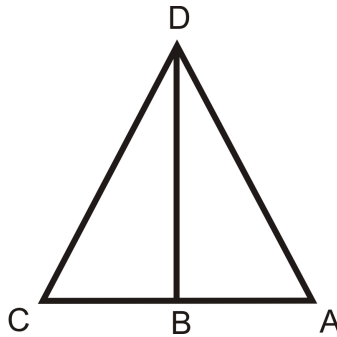

Given: \overline{BD} is an angle bisector of $\angle CDA$, $\angle C \cong \angle A$

Prove: $\triangle CBD \cong \triangle ABD$

3. Write a two-column proof.

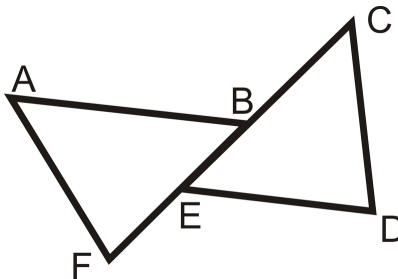

Given: $\overline{AB} \parallel \overline{ED}$, $\angle C \cong \angle F$, $\overline{AB} \cong \overline{ED}$

Prove: $\overline{AF} \cong \overline{CD}$

Answers:

1. Even though $\overline{KL} \cong \overline{ST}$, they are not corresponding. Look at the angles around \overline{KL} , $\angle K$ and $\angle L$. $\angle K$ has **one** arc and $\angle L$ is unmarked. The angles around \overline{ST} are $\angle S$ and $\angle T$. $\angle S$ has **two** arcs and $\angle T$ is unmarked. In order to use AAS, $\angle S$ needs to be congruent to $\angle K$. They are not congruent because the arcs marks are different. Therefore, we cannot conclude that these two triangles are congruent.

2. Here is the proof:

TABLE 4.12:

| <i>Statement</i> | <i>Reason</i> |
|---|---------------------------------|
| 1. \overline{BD} is an angle bisector of $\angle CDA$, $\angle C \cong \angle A$ | Given |
| 2. $\angle CDB \cong \angle ADB$ | Definition of an Angle Bisector |
| 3. $\overline{DB} \cong \overline{DB}$ | Reflexive PoC |
| 3. $\triangle CBD \cong \triangle ABD$ | AAS |

3. First, prove that the triangles are congruent. Once you have proved they are congruent, you need one more step to show that the corresponding pair of sides must be congruent. Remember that CPCTC stands for *corresponding parts of congruent triangles are congruent*.

TABLE 4.13:

| <i>Statement</i> | <i>Reason</i> |
|--|-----------------------------------|
| 1. $\overline{AB} \parallel \overline{ED}, \angle C \cong \angle F, \overline{AB} \cong \overline{ED}$ | Given |
| 2. $\angle ABE \cong \angle DEB$ | Alternate Interior Angles Theorem |
| 3. $\triangle ABF \cong \triangle DEC$ | ASA |
| 4. $\overline{AF} \cong \overline{CD}$ | CPCTC |

Practice

For questions 1-3, determine if the triangles are congruent. If they are, write the congruence statement and which congruence postulate or theorem you used.

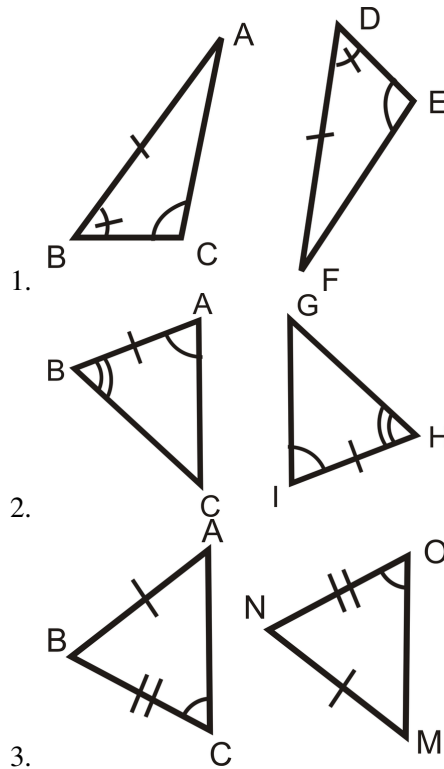

For questions 4-8, use the picture and the given information below.

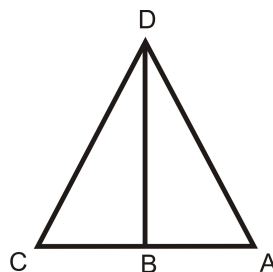

Given: $\overline{DB} \perp \overline{AC}$, \overline{DB} is the angle bisector of $\angle CDA$

4. From $\overline{DB} \perp \overline{AC}$, which angles are congruent and why?
5. Because \overline{DB} is the angle bisector of $\angle CDA$, what two angles are congruent?
6. From looking at the picture, what additional piece of information are you given? Is this enough to prove the two triangles are congruent?
7. Write a two-column proof to prove $\triangle CDB \cong \triangle ADB$, using #4-6.
8. What would be your reason for $\angle C \cong \angle A$?

For questions 9-13, use the picture and the given information.

Given: $\overline{LP} \parallel \overline{NO}$, $\overline{LP} \cong \overline{NO}$

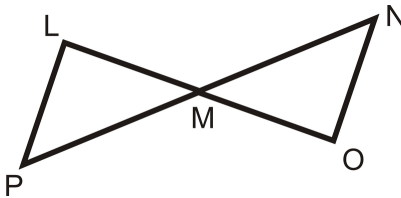

9. From $\overline{LP} \parallel \overline{NO}$, which angles are congruent and why?
10. From looking at the picture, what additional piece of information can you conclude?
11. Write a two-column proof to prove $\triangle LMP \cong \triangle ONM$.
12. What would be your reason for $\overline{LM} \cong \overline{MO}$?
13. Fill in the blanks for the proof below. Prove: M is the midpoint of \overline{PN} .

TABLE 4.14:

Statement

1. $\overline{LP} \parallel \overline{NO}$, $\overline{LP} \cong \overline{NO}$

2.

3.

4. $\overline{LM} \cong \overline{MO}$

5. M is the midpoint of \overline{PN} .

Reason

1. Given

2. Alternate Interior Angles

3. ASA

4.

5.

Determine the additional piece of information needed to show the two triangles are congruent by the given postulate.

14. AAS

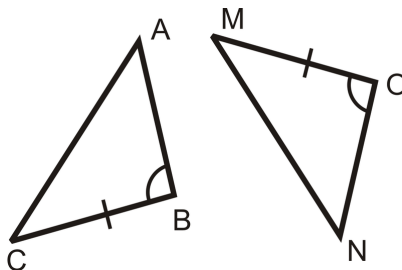

15. ASA

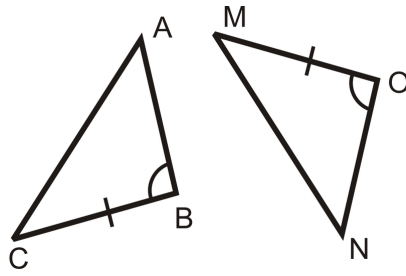

16. ASA

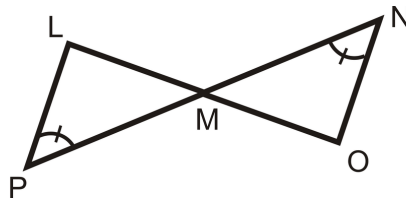

17. AAS

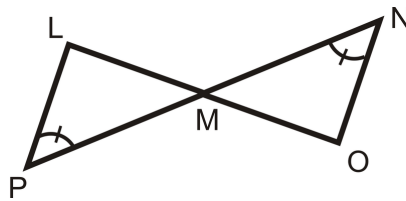

4.9 HL Triangle Congruence

Here you'll learn how to prove that right triangles are congruent given the length of only their hypotenuses and one of their legs.

What if you were given two right triangles and provided with only the measure of their hypotenuses and one of their legs? How could you determine if the two right triangles were congruent? After completing this Concept, you'll be able to use the Hypotenuse-Leg (HL) shortcut to prove right triangles are congruent.

Watch This



MEDIA

Click image to the left for more content.

[CK-12 Foundation: Chapter4HLTriangleCongruenceA](#)

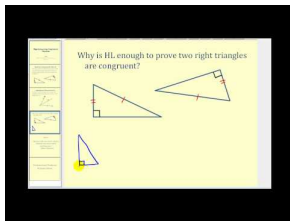

MEDIA

Click image to the left for more content.

[James Sousa:Hypotenuse-Leg Congruence Theorem](#)

Guidance

Recall that a right triangle has exactly one right angle. The two sides adjacent to the right angle are called legs and the side opposite the right angle is called the hypotenuse.

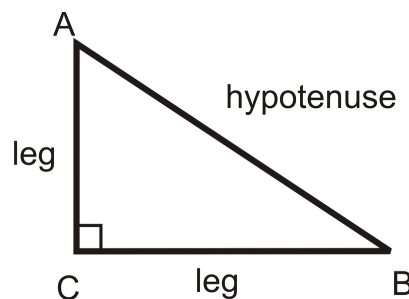

The Pythagorean Theorem says, for any **right** triangle, $(leg)^2 + (leg)^2 = (hypotenuse)^2$. What this means is that if you are given two sides of a right triangle, you can always find the third. Therefore, if you know that two sides

of a *right* triangle are congruent to two sides of another *right* triangle, you can conclude that third sides are also congruent.

HL Triangle Congruence Theorem: If the hypotenuse and leg in one right triangle are congruent to the hypotenuse and leg in another right triangle, then the two triangles are congruent.

The markings in the picture are enough to say $\triangle ABC \cong \triangle XYZ$.

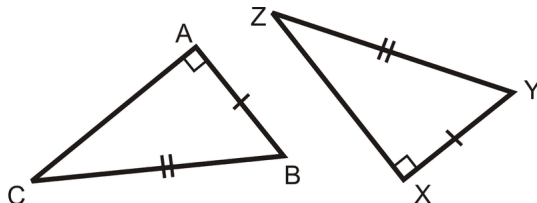

Notice that this theorem is only used with a hypotenuse and a leg. If you know that the two legs of a right triangle are congruent to two legs of another triangle, the two triangles would be congruent by SAS, because the right angle would be between them.

Example A

What information would you need to prove that these two triangles are congruent using the HL Theorem?

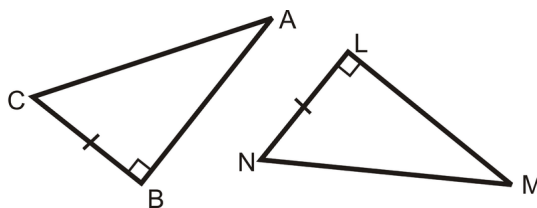

For HL, you need the hypotenuses to be congruent. So, $\overline{AC} \cong \overline{MN}$.

Example B

Determine if the triangles are congruent. If they are, write the congruence statement and which congruence postulate or theorem you used.

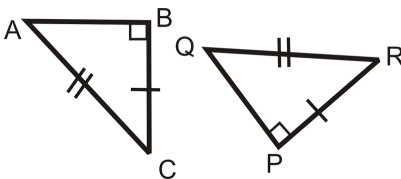

We know the two triangles are right triangles. They have one pair of legs that is congruent and their hypotenuses are congruent. This means that $\triangle ABC \cong \triangle RQP$ by HL.

Example C

Determine the additional piece of information needed to show the two triangles are congruent by HL.

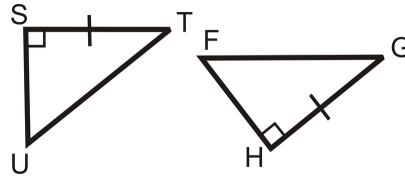

We already know one pair of legs is congruent and that they are right triangles. The additional piece of information we need is that the two hypotenuses are congruent, $\overline{UT} \cong \overline{FG}$.

Watch this video for help with the Examples above.



MEDIA

Click image to the left for more content.

[CK-12 Foundation: Chapter4HLTriangleCongruenceB](#)

Vocabulary

Two figures are **congruent** if they have exactly the same size and shape. By definition, two triangles are **congruent** if the three corresponding angles and sides are congruent. The symbol \cong means congruent. There are shortcuts for proving that triangles are congruent. The **HL Triangle Congruence Theorem** states that if the hypotenuse and leg in one right triangle are congruent to the hypotenuse and leg in another right triangle, then the two triangles are congruent. A **right triangle** has exactly one right (90°) angle. The two sides adjacent to the right angle are called **legs** and the side opposite the right angle is called the **hypotenuse**. HL can only be used with right triangles.

Guided Practice

1. Determine if the triangles are congruent. If they are, write the congruence statement and which congruence postulate or theorem you used.

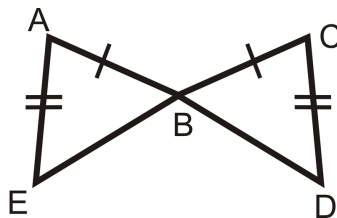

2. Fill in the blanks in the proof below.

Given:

$$\overline{SV} \perp \overline{WU}$$

T is the midpoint of \overline{SV} and \overline{WU}

Prove: $\overline{WS} \cong \overline{UV}$

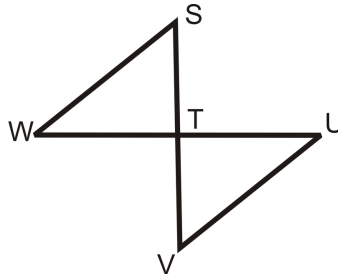

TABLE 4.15:

| <i>Statement</i> | <i>Reason</i> |
|--|---------------|
| 1. | 1. |
| 2. $\angle STW$ and $\angle UTV$ are right angles | 2. |
| 3. | 3. |
| 4. $\overline{ST} \cong \overline{TV}$, $\overline{WT} \cong \overline{TU}$ | 4. |
| 5. $\triangle STW \cong \triangle UTV$ | 5. |
| 6. $\overline{WS} \cong \overline{UV}$ | 6. |

3. If two right triangles have congruent hypotenuses and one pair of non-right angles that are congruent, are the two right triangles definitively congruent?

Answers:

1. All we know is that two pairs of sides are congruent. Since we do not know if these are right triangles, we cannot use HL. We do not know if these triangles are congruent.

2.

TABLE 4.16:

| <i>Statement</i> | <i>Reason</i> |
|--|---------------------------------------|
| 1. $\overline{SV} \perp \overline{WU}$ | 1. Given |
| 2. $\angle STW$ and $\angle UTV$ are right angles | 2. Definition of perpendicular lines. |
| 3. T is the midpoint of \overline{SV} and \overline{WU} | 3. Given |
| 4. $\overline{ST} \cong \overline{TV}$, $\overline{WT} \cong \overline{TU}$ | 4. Definition of midpoint |
| 5. $\triangle STW \cong \triangle UTV$ | 5. SAS |
| 6. $\overline{WS} \cong \overline{UV}$ | 6. CPCTC |

Note that even though these were right triangles, we did not use the HL congruence shortcut because we were not originally given that the two hypotenuses were congruent. The SAS congruence shortcut was quicker in this case.

3. Yes, by the AAS Congruence shortcut. One pair of congruent angles is the right angles, and another pair is given. The congruent pair of sides are the hypotenuses that are congruent. Note that just like in #2, even though the triangles are right triangles, it is possible to use a congruence shortcut other than HL to prove the triangles are congruent.

Practice

Using the HL Theorem, what information do you need to prove the two triangles are congruent?

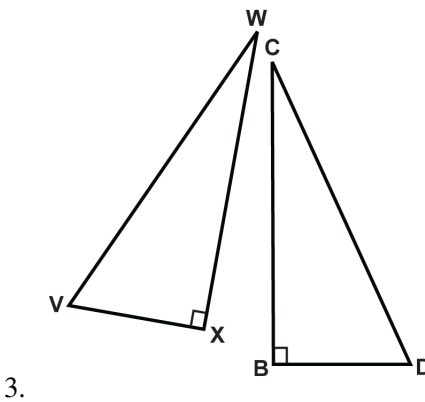
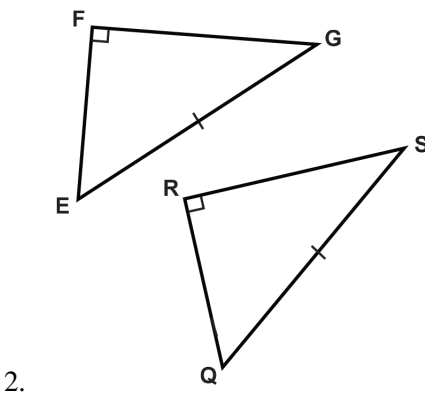
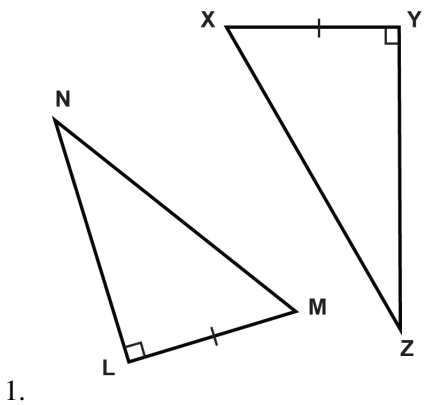

The triangles are formed by two parallel lines cut by a perpendicular transversal. C is the midpoint of \overline{AD} . Complete the proof to show the two triangles are congruent.

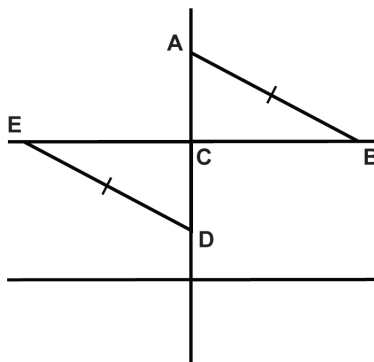

TABLE 4.17:

| Statement | Reason |
|--|------------------------|
| 1. $\angle ACB$ and $\angle DCE$ are right angles. | (4.) |
| 2. (5.) | Definition of midpoint |
| 3. (6.) | Given |
| 4. $\triangle ACD \cong \triangle DCE$ | (7.) |

Based on the following details, are the two right triangles definitively congruent?

8. The hypotenuses of two right triangles are congruent.
9. Both sets of legs in the two right triangles are congruent.
10. One set of legs are congruent in the two right triangles.
11. The hypotenuses and one pair of legs are congruent in the two right triangles.
12. One of the non right angles of the two right triangles is congruent.
13. All of the angles of the two right triangles are congruent.
14. All of the sides of the two right triangles are congruent.
15. Both triangles have one leg that is twice the length of the other.

4.10 Isosceles Triangles

Here you'll learn the definition of an isosceles triangle as well as two theorems about isosceles triangles.

What if you were presented with an isosceles triangle and told that its base angles measure x° and y° ? What could you conclude about x and y ? After completing this Concept, you'll be able to apply important properties about isosceles triangles to help you solve problems like this one.

Watch This



MEDIA

Click image to the left for more content.

CK-12 Foundation: Chapter4IsoscelesTrianglesA

Watch the first part of this video.

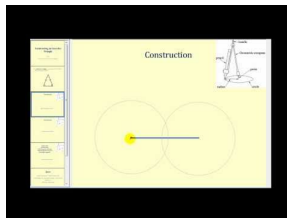

MEDIA

Click image to the left for more content.

James Sousa:HowTo Construct AnIsosceles Triangle

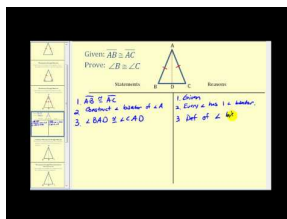

MEDIA

Click image to the left for more content.

James Sousa:Proof of the Isosceles TriangleTheorem

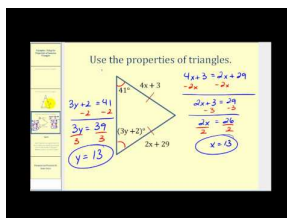

MEDIA

Click image to the left for more content.

James Sousa:Using the Properties ofIsosceles Trianglesto Determine Values

Guidance

An isosceles triangle is a triangle that has *at least* two congruent sides. The congruent sides of the isosceles triangle are called the *legs*. The other side is called the *base* and the angles between the base and the congruent sides are called *base angles*. The angle made by the two legs of the isosceles triangle is called the *vertex angle*.

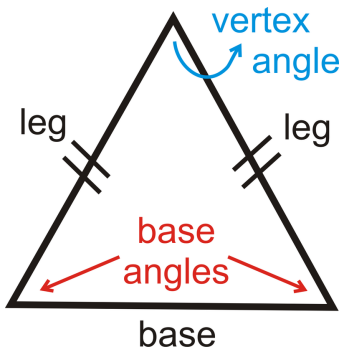

Investigation: Isosceles Triangle Construction

Tools Needed: pencil, paper, compass, ruler, protractor

- Using your compass and ruler, draw an isosceles triangle with sides of 3 in, 5 in and 5 in. Draw the 3 in side (the base) horizontally 6 inches from the top of the page.

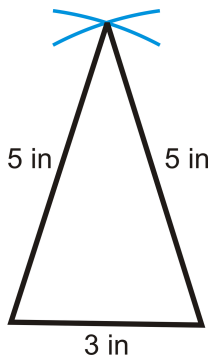

- Now that you have an isosceles triangle, use your protractor to measure the base angles and the vertex angle.

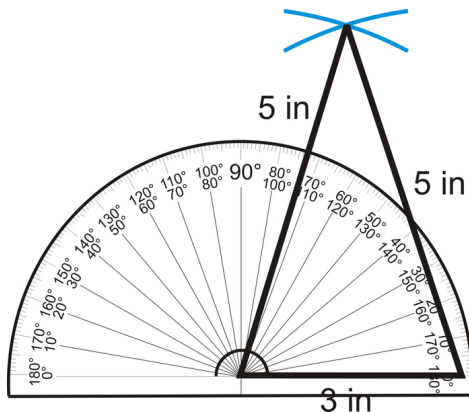

The base angles should each be 72.5° and the vertex angle should be 35° .

We can generalize this investigation into the Base Angles Theorem.

Base Angles Theorem: The base angles of an isosceles triangle are congruent.

To prove the Base Angles Theorem, we will construct the angle bisector through the vertex angle of an isosceles triangle.

Given: Isosceles triangle $\triangle DEF$ with $\overline{DE} \cong \overline{EF}$

Prove: $\angle D \cong \angle F$

TABLE 4.18:

Statement

1. Isosceles triangle $\triangle DEF$ with $\overline{DE} \cong \overline{EF}$
2. Construct angle bisector \overline{EG} for $\angle E$

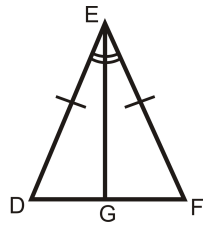

Reason

- Given
Every angle has one angle bisector

3. $\angle DEG \cong \angle FEG$
4. $\overline{EG} \cong \overline{EG}$
5. $\triangle DEG \cong \triangle FEG$
6. $\angle D \cong \angle F$

- Definition of an angle bisector
Reflexive PoC
SAS
CPCTC

By constructing the angle bisector, \overline{EG} , we designed two congruent triangles and then used CPCTC to show that the base angles are congruent. Now that we have proven the Base Angles Theorem, you do not have to construct the angle bisector every time. It can now be assumed that base angles of any isosceles triangle are always equal. Let's further analyze the picture from step 2 of our proof.

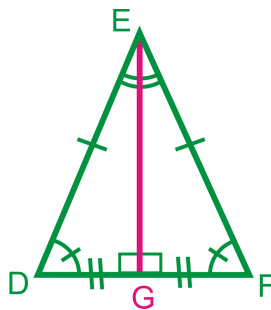

Because $\triangle DEG \cong \triangle FEG$, we know that $\angle EGD \cong \angle EGF$ by CPCTC. These two angles are also a linear pair, so they are congruent supplements, or 90° each. Therefore, $\overline{EG} \perp \overline{DF}$. Additionally, $\overline{DG} \cong \overline{GF}$ by CPCTC, so G is the midpoint of \overline{DF} . This means that \overline{EG} is the **perpendicular bisector** of \overline{DF} , in addition to being the angle bisector of $\angle DEF$.

Isosceles Triangle Theorem: The angle bisector of the vertex angle in an isosceles triangle is also the perpendicular bisector to the base.

The converses of the Base Angles Theorem and the Isosceles Triangle Theorem are both true.

Base Angles Theorem Converse: If two angles in a triangle are congruent, then the opposite sides are also congruent.

So, for a triangle $\triangle ABC$, if $\angle A \cong \angle B$, then $\overline{CB} \cong \overline{CA}$. $\angle C$ would be the vertex angle.

Isosceles Triangle Theorem Converse: The perpendicular bisector of the base of an isosceles triangle is also the angle bisector of the vertex angle.

In other words, if $\triangle ABC$ is isosceles, $\overline{AD} \perp \overline{CB}$ and $\overline{CD} \cong \overline{DB}$, then $\angle CAD \cong \angle BAD$.

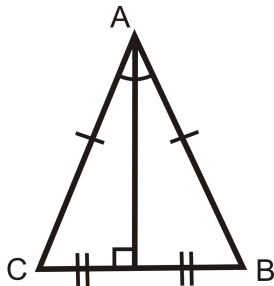

Example A

Which two angles are congruent?

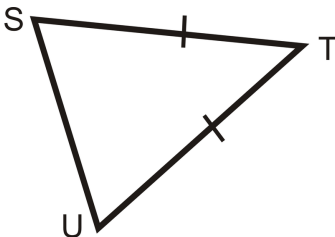

This is an isosceles triangle. The congruent angles, are opposite the congruent sides.

From the arrows we see that $\angle S \cong \angle U$.

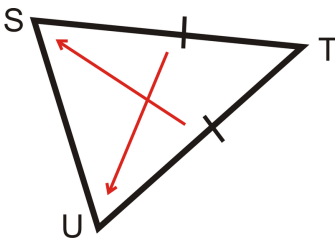

Example B

If an isosceles triangle has base angles with measures of 47° , what is the measure of the vertex angle?

Draw a picture and set up an equation to solve for the vertex angle, v .

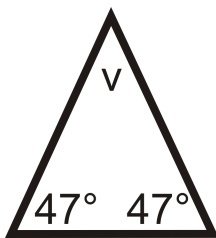

$$\begin{aligned}
 47^\circ + 47^\circ + v &= 180^\circ \\
 v &= 180^\circ - 47^\circ - 47^\circ \\
 v &= 86^\circ
 \end{aligned}$$

Example C

If an isosceles triangle has a vertex angle with a measure of 116° , what is the measure of each base angle? Draw a picture and set up an equation to solve for the base angles, b . Recall that the base angles are equal.

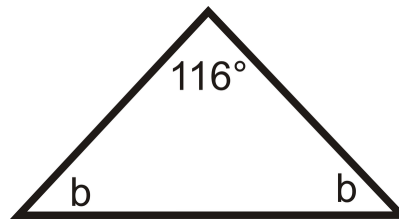

$$\begin{aligned}
 116^\circ + b + b &= 180^\circ \\
 2b &= 64^\circ \\
 b &= 32^\circ
 \end{aligned}$$

Watch this video for help with the Examples above.



MEDIA

Click image to the left for more content.

[CK-12 Foundation: Chapter4IsoscelesTrianglesB](#)

Vocabulary

An isosceles triangle is a triangle that has **at least** two congruent sides. The congruent sides of the isosceles triangle are called the **legs**. The other side is called the **base**. The angles between the base and the legs are called **base angles**. The angle made by the two legs is called the **vertex angle**.

Guided Practice

1. Find the value of x and the measure of each angle.

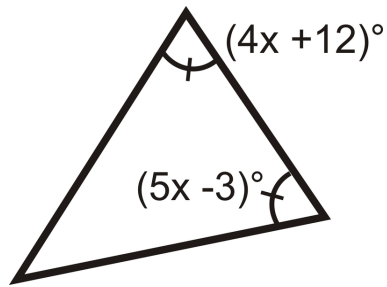

2. Find the measure of x .

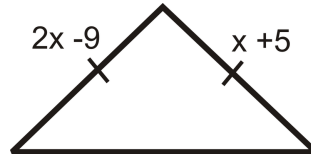

3. True or false: Base angles of an isosceles triangle can be right angles.

Answers:

1. Set the angles equal to each other and solve for x .

$$\begin{aligned}(4x + 12)^\circ &= (5x - 3)^\circ \\ 15^\circ &= x\end{aligned}$$

If $x = 15^\circ$, then the base angles are $4(15^\circ) + 12^\circ$, or 72° . The vertex angle is $180^\circ - 72^\circ - 72^\circ = 36^\circ$.

2. The two sides are equal, so set them equal to each other and solve for x .

$$\begin{aligned}2x - 9 &= x + 5 \\ x &= 14\end{aligned}$$

3. This statement is false. Because the base angles of an isosceles triangle are congruent, if one base angle is a right angle then both base angles must be right angles. It is impossible to have a triangle with two right (90°) angles. The Triangle Sum Theorem states that the sum of the three angles in a triangle is 180° . If two of the angles in a triangle are right angles, then the third angle must be 0° and the shape is no longer a triangle.

Practice

Find the measures of x and/or y .

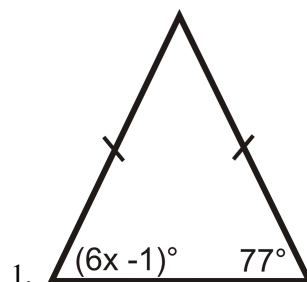

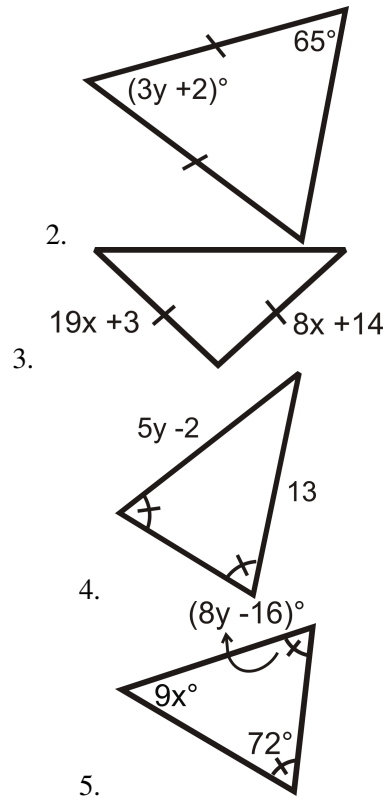

Determine if the following statements are true or false.

6. Base angles of an isosceles triangle are congruent.
7. Base angles of an isosceles triangle are complementary.
8. Base angles of an isosceles triangle can be equal to the vertex angle.
9. Base angles of an isosceles triangle are acute.

Complete the proofs below.

10. Given: Isosceles $\triangle CIS$, with base angles $\angle C$ and $\angle S$ $\overline{SI\overline{O}}$ is the angle bisector of $\angle CIS$ Prove: \overline{IO} is the perpendicular bisector of \overline{CS}

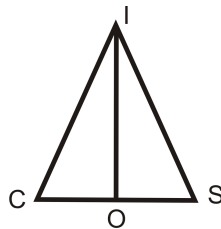

11. Given: Isosceles $\triangle ICS$ with $\angle C$ and $\angle S$ $\overline{SI\overline{O}}$ is the perpendicular bisector of \overline{CS} Prove: \overline{IO} is the angle bisector of $\angle CIS$

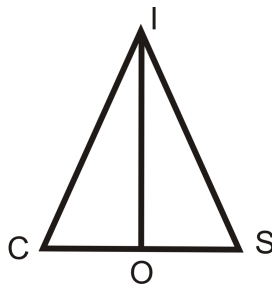

On the $x - y$ plane, plot the coordinates and determine if the given three points make a scalene or isosceles triangle.

12. $(-2, 1), (1, -2), (-5, -2)$
13. $(-2, 5), (2, 4), (0, -1)$
14. $(6, 9), (12, 3), (3, -6)$
15. $(-10, -5), (-8, 5), (2, 3)$
16. $(-1, 2), (7, 2), (3, 9)$

4.11 Equilateral Triangles

Here you'll learn the definition of an equilateral triangle as well as an important theorem about equilateral triangles. What if your parents want to redo the bathroom? Below is the tile they would like to place in the shower. The blue and green triangles are all equilateral. What type of polygon is dark blue outlined figure? Can you determine how many degrees are in each of these figures? Can you determine how many degrees are around a point? After completing this Concept, you'll be able to apply important properties about equilateral triangles to help you solve problems like this one.

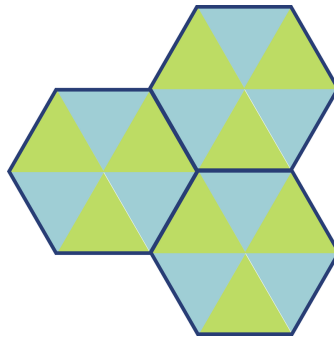

Watch This



MEDIA

Click image to the left for more content.

CK-12 Foundation: Chapter4EquilateralTrianglesA

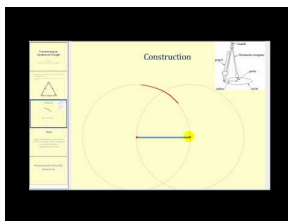

MEDIA

Click image to the left for more content.

James Sousa:Constructing anEquilateralTriangle

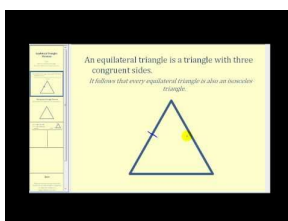

MEDIA

Click image to the left for more content.

James Sousa:EquilateralTriangles Theorem

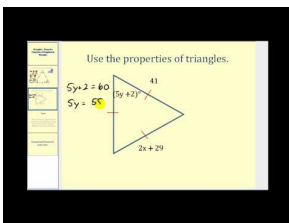

MEDIA

Click image to the left for more content.

James Sousa:Using the Properties ofEquilateralTriangles

Guidance

By definition, all sides in an equilateral triangle have exactly the same length.

Investigation: Constructing an Equilateral Triangle

Tools Needed: pencil, paper, compass, ruler, protractor

1. Because all the sides of an equilateral triangle are equal, pick a length to be all the sides of the triangle. Measure this length and draw it horizontally on your paper.



2. Put the pointer of your compass on the left endpoint of the line you drew in Step 1. Open the compass to be the same width as this line. Make an arc above the line.

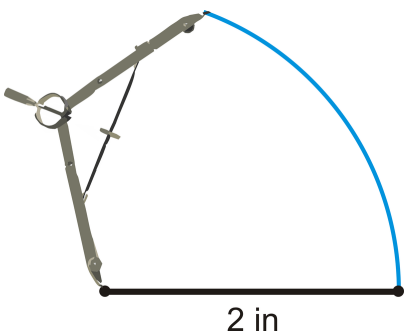

3. Repeat Step 2 on the right endpoint.

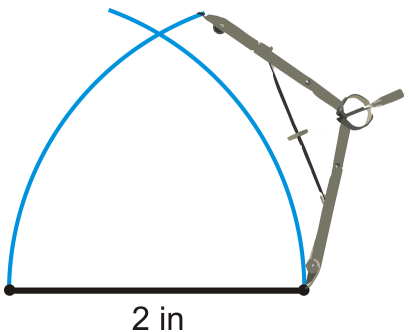

4. Connect each endpoint with the arc intersections to make the equilateral triangle.

Use the protractor to measure each angle of your constructed equilateral triangle. What do you notice?

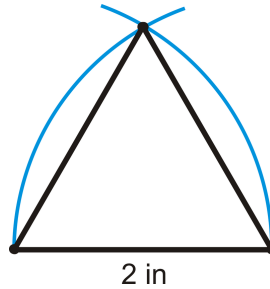

From the Base Angles Theorem, the angles opposite congruent sides in an isosceles triangle are congruent. So, if all three sides of the triangle are congruent, then all of the angles are congruent or 60° each.

Equilateral Triangles Theorem: All equilateral triangles are also equiangular. Also, all equiangular triangles are also equilateral.

Example A

Find the value of x .

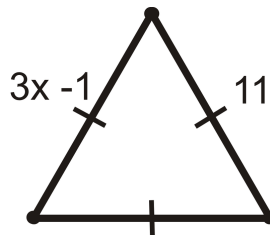

Because this is an equilateral triangle $3x - 1 = 11$. Now, we have an equation, solve for x .

$$3x - 1 = 11$$

$$3x = 12$$

$$x = 4$$

Example B

Find the values of x and y .

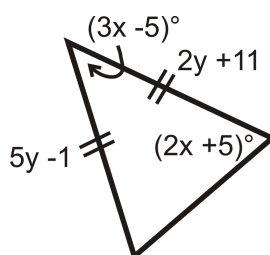

Let's start with y . Both sides are equal, so set the two expressions equal to each other and solve for y .

$$\begin{aligned}5y - 1 &= 2y + 11 \\3y &= 12 \\y &= 4\end{aligned}$$

For x , we need to use two $(2x + 5)^\circ$ expressions because this is an isosceles triangle and that is the base angle measurement. Set all the angles equal to 180° and solve.

$$\begin{aligned}(2x + 5)^\circ + (2x + 5)^\circ + (3x - 5)^\circ &= 180^\circ \\(7x + 5)^\circ &= 180^\circ \\7x &= 175^\circ \\x &= 25^\circ\end{aligned}$$

Example C

Two sides of an equilateral triangle are $2x + 5$ units and $x + 13$ units. How long is each side of this triangle?

The two given sides must be equal because this is an equilateral triangle. Write and solve the equation for x .

$$\begin{aligned}2x + 5 &= x + 13 \\x &= 8\end{aligned}$$

To figure out how long each side is, plug in 8 for x in either of the original expressions. $2(8) + 5 = 21$. Each side is 21 units.

Watch this video for help with the Examples above.



MEDIA

Click image to the left for more content.

[CK-12 Foundation: Chapter4EquilateralTrianglesB](#)

Concept Problem Revisited

Let's focus on one tile. First, these triangles are all equilateral, so this is an equilateral hexagon (6 sided polygon). Second, we now know that every equilateral triangle is also equiangular, so every triangle within this tile has 360° angles. This makes our equilateral hexagon also equiangular, with each angle measuring 120° . Because there are 6 angles, the sum of the angles in a hexagon are $6 \cdot 120^\circ$ or 720° . Finally, the point in the center of this tile, has 660° angles around it. That means there are 360° around a point.

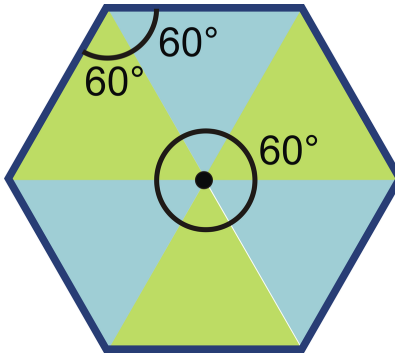

Vocabulary

An *isosceles triangle* is a triangle that has **at least** two congruent sides. The congruent sides of the isosceles triangle are called the *legs*. The other side is called the *base*. The angles between the base and the legs are called *base angles* and are always congruent by the **Base Angles Theorem**. The angle made by the two legs is called the *vertex angle*. An *equilateral triangle* is a triangle with three congruent sides. **Equiangular** means all angles are congruent. All equilateral triangles are equiangular.

Guided Practice

- Find the measure of y .

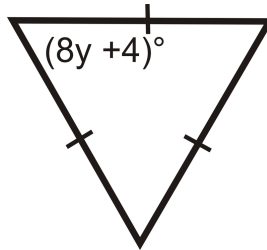

- Fill in the proof:

Given: Equilateral $\triangle RST$ with

$$\overline{RT} \cong \overline{ST} \cong \overline{RS}$$

Prove: $\triangle RST$ is equiangular

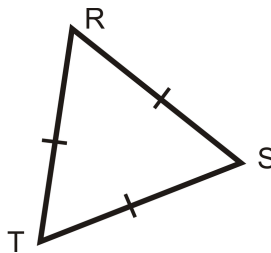

TABLE 4.19:

Statement

1.

Reason

1. Given

TABLE 4.19: (continued)

| <i>Statement</i> | <i>Reason</i> |
|-----------------------------------|------------------------|
| 2. | 2. Base Angles Theorem |
| 3. | 3. Base Angles Theorem |
| 4. | 4. Transitive PoC |
| 5. $\triangle RST$ is equiangular | 5. |

3. True or false: All equilateral triangles are isosceles triangles.

Answers:

1. The markings show that all angles are congruent. Since all three angles must add up to 180° this means that each angle must equal 60° . Write and solve an equation:

$$8y + 4 = 60$$

$$8y = 56$$

$$y = 7$$

2.

TABLE 4.20:

| <i>Statement</i> | <i>Reason</i> |
|--|-------------------------------|
| 1. $\overline{RT} \cong \overline{ST} \cong \overline{RS}$ | 1. Given |
| 2. $\angle R \cong \angle S$ | 2. Base Angles Theorem |
| 3. $\angle T \cong \angle R$ | 3. Base Angles Theorem |
| 4. $\angle T \cong \angle S$ | 4. Transitive PoC |
| 5. $\triangle RST$ is equiangular | 5. Definition of equiangular. |

3. This statement is true. The definition of an isosceles triangle is a triangle with at least two congruent sides. Since all equilateral triangles have three congruent sides, they fit the definition of an isosceles triangle.

Practice

The following triangles are equilateral triangles. Solve for the unknown variables.

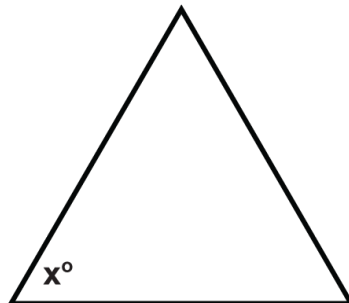

1.

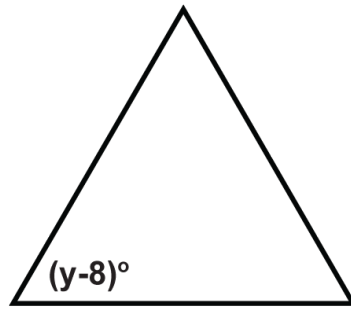

2.

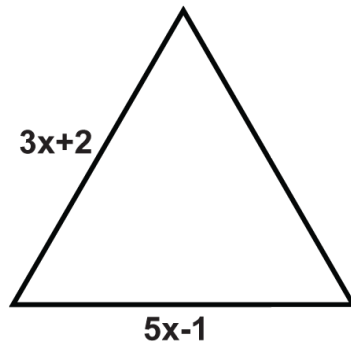

3.

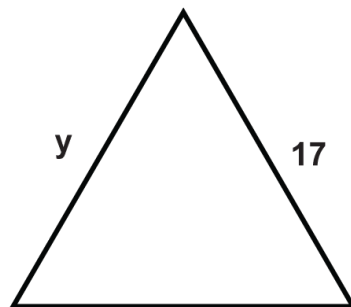

4.

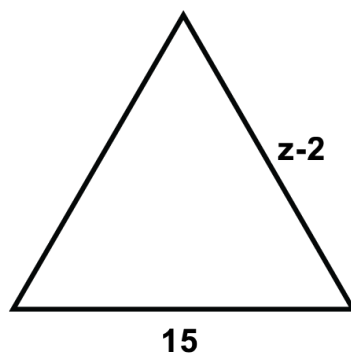

5.

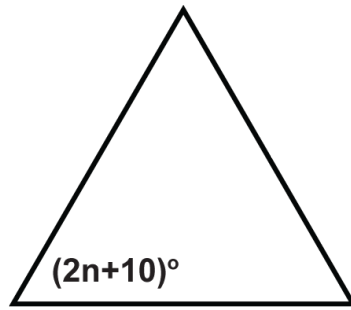

6.

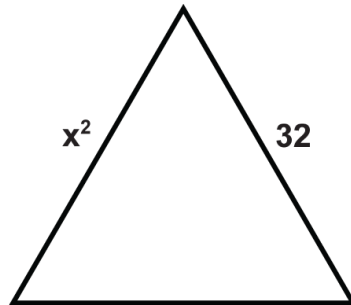

7.

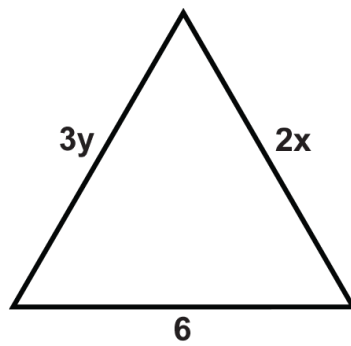

8.

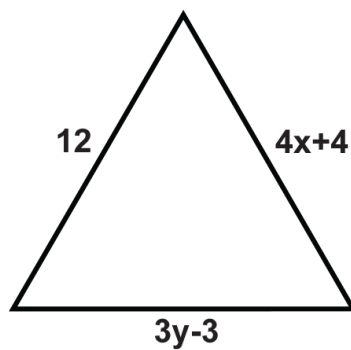

9.

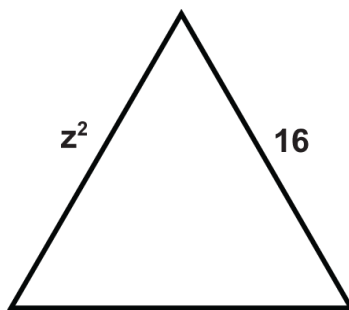

10.

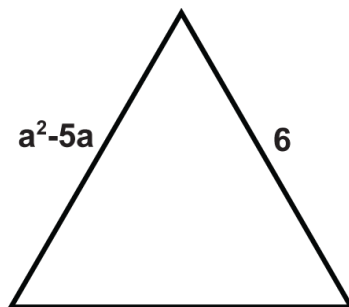

11.

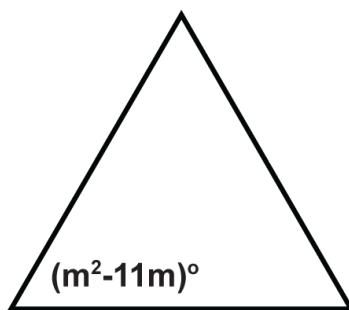

12.

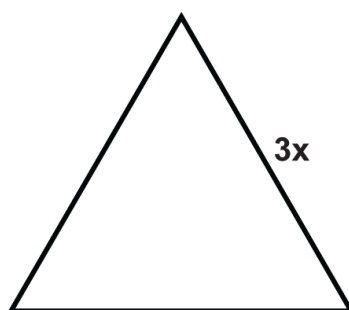

13.

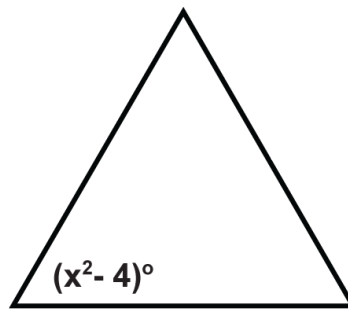

14.

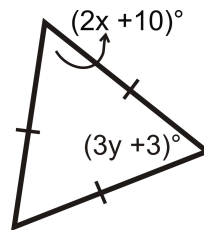
15. Find the measures of x and y .

Summary

This chapter begins with the Triangle Sum Theorem, showing that the sum of the angles in a triangle is a constant. The definition of congruency is presented and from that foundation the chapter presents other important theorems related to congruent triangles, such as the Third Angle Theorem and the SSS, SAS, ASA, AAS and HL Triangle Congruence Theorems.

Chapter Keywords

- Interior Angles
- Vertex
- Triangle Sum Theorem
- Exterior Angle
- Exterior Angle Sum Theorem
- Remote Interior Angles
- Exterior Angle Theorem
- Congruent Triangles
- Third Angle Theorem
- Reflexive Property of Congruence
- Symmetric Property of Congruence
- Transitive Property of Congruence
- Side-Side-Side (SSS) Triangle Congruence Postulate
- Included Angle
- Side-Angle-Side (SAS) Triangle Congruence Postulate
- Angle-Side-Angle (ASA) Congruence Postulate
- Angle-Angle-Side (AAS or SAA) Congruence Theorem
- HL Congruence Theorem
- Base Angles Theorem

- Isosceles Triangle Theorem
- Base Angles Theorem Converse
- Isosceles Triangle Theorem Converse
- Equilateral Triangles Theorem

Chapter Review

For each pair of triangles, write what needs to be congruent in order for the triangles to be congruent. Then, write the congruence statement for the triangles.

1. HL

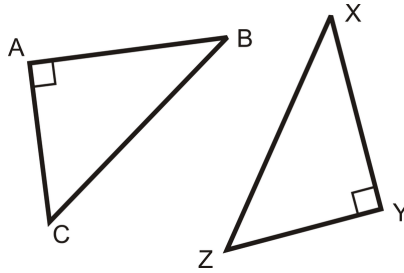

2. ASA

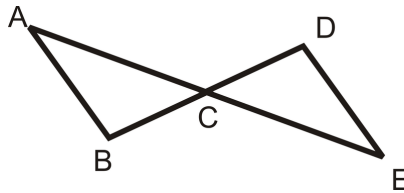

3. AAS

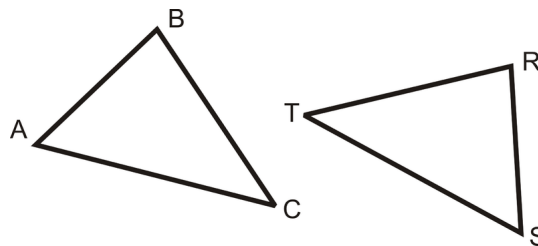

4. SSS

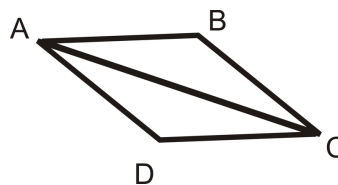

5. SAS

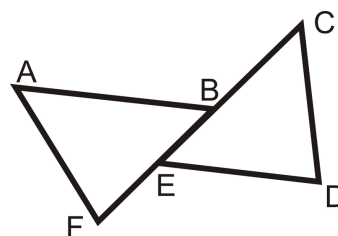

Using the pictures below, determine which theorem, postulate or definition that supports each statement below.

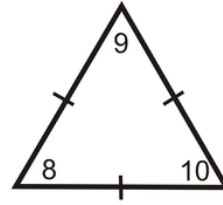
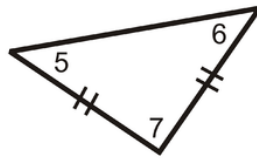
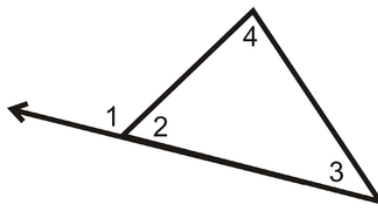

6. $m\angle 1 + m\angle 2 = 180^\circ$
7. $\angle 5 \cong \angle 6$
8. $m\angle 1 = m\angle 4 + m\angle 3$
9. $m\angle 8 = 60^\circ$
10. $m\angle 5 + m\angle 6 + m\angle 7 = 180^\circ$
11. $\angle 8 \cong \angle 9 \cong \angle 10$
12. If $m\angle 7 = 90^\circ$, then $m\angle 5 = m\angle 6 = 45^\circ$

Texas Instruments Resources

In the CK-12 Texas Instruments Geometry FlexBook, there are graphing calculator activities designed to supplement the objectives for some of the lessons in this chapter. See <http://www.ck12.org/flexr/chapter/9689>.

Relationships with Triangles

Chapter Outline

- 5.1 MIDSEGMENT THEOREM
 - 5.2 PERPENDICULAR BISECTORS
 - 5.3 ANGLE BISECTORS IN TRIANGLES
 - 5.4 MEDIANS
 - 5.5 ALTITUDES
 - 5.6 COMPARING ANGLES AND SIDES IN TRIANGLES
 - 5.7 TRIANGLE INEQUALITY THEOREM
 - 5.8 INDIRECT PROOF IN ALGEBRA AND GEOMETRY
-

Introduction

This chapter introduces different segments within triangles and how they relate to each other. We will explore the properties of midsegments, perpendicular bisectors, angle bisectors, medians, and altitudes. Next, we will look at the relationship of the sides of a triangle, how they relate to each other and how the sides of one triangle can compare to another.

5.1 Midsegment Theorem

Here you'll learn what a midsegment is, and how midsegments in triangles relate to the triangles.

What if you created a repeated design using the same shape (or shapes) of different sizes? This would be called a fractal. Below, is an example of the first few steps of one. What does the next figure look like? How many triangles are in each figure (green and white triangles)? Is there a pattern? After completing this Concept, you'll be able to better understand how these fractals are created.



Watch This



MEDIA

Click image to the left for more content.

[CK-12 Foundation: Chapter5MidsegmentTheoremA](#)

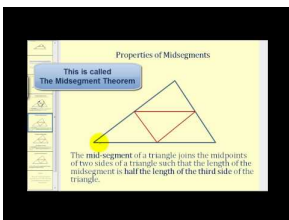

MEDIA

Click image to the left for more content.

[James Sousa:Introduction totheMidsegmentsof a Triangle](#)

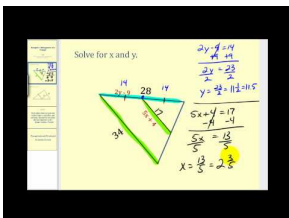

MEDIA

Click image to the left for more content.

[James Sousa:DeterminingUnknownValues Using Propertiesof the Midsegments of aTriangle](#)

Guidance

A **midsegment** is a line segment that connects two midpoints of adjacent sides of a triangle. For every triangle there are three midsegments. The **Midsegment Theorem** states that the midsegment of a triangle is half the length of the side it is parallel to.

Example A

Draw the midsegment \overline{DF} between \overline{AB} and \overline{BC} . Use appropriate tic marks.

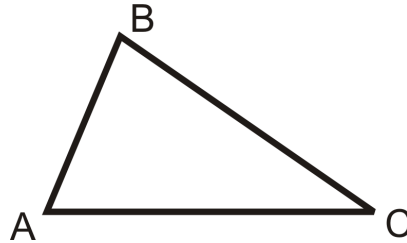

Find the midpoints of \overline{AB} and \overline{BC} using your ruler. Label these points D and F . Connect them to create the midsegment.

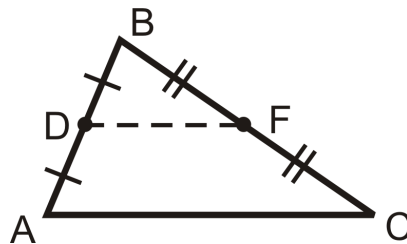

Don't forget to put the tic marks, indicating that D and F are midpoints, $\overline{AD} \cong \overline{DB}$ and $\overline{BF} \cong \overline{FC}$.

Example B

Find the midpoint of \overline{AC} from $\triangle ABC$. Label it E and find the other two midsegments of the triangle.

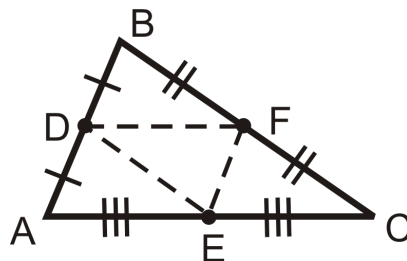

Example C

Mark everything you have learned from the Midsegment Theorem on $\triangle ABC$.

Let's draw two different triangles, one for the congruent sides, and one for the parallel lines.

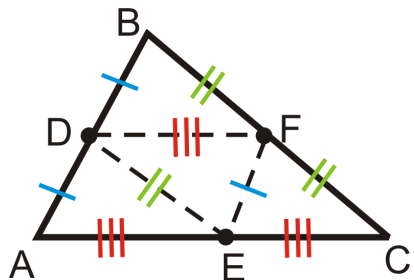

Because the midsegments are half the length of the sides they are parallel to, they are congruent to half of each of those sides (as marked). Also, this means that all four of the triangles in $\triangle ABC$, created by the midsegments are congruent by SSS.

As for the parallel midsegments and sides, several congruent angles are formed. In the picture to the right, the pink and teal angles are congruent because they are corresponding or alternate interior angles. Then, the purple angles are congruent by the 3rd Angle Theorem.

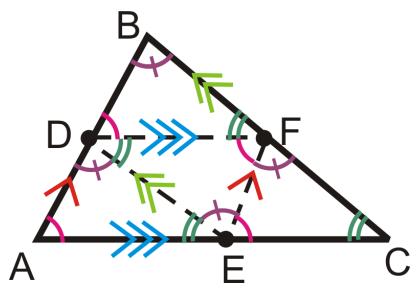

To play with the properties of midsegments, go to <http://www.mathopenref.com/trianglemidsegment.html>.

Example D

$M, N,$ and O are the midpoints of the sides of the triangle.

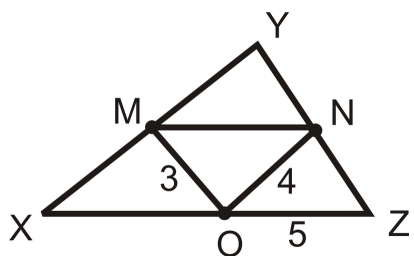

Find

- a) MN
- b) XY
- c) The perimeter of $\triangle XYZ$

Use the Midsegment Theorem.

- a) $MN = OZ = 5$
- b) $XY = 2(ON) = 2 \cdot 4 = 8$
- c) The perimeter is the sum of the three sides of $\triangle XYZ$.

$$XY + YZ + XZ = 2 \cdot 4 + 2 \cdot 3 + 2 \cdot 5 = 8 + 6 + 10 = 24$$

Watch this video for help with the Examples above.



MEDIA

Click image to the left for more content.

[CK-12 Foundation: Chapter5MidsegmentTheoremB](#)

Concept Problem Revisited

To the left is a picture of the 4th figure in the fractal pattern. The number of triangles in each figure is 1, 4, 13, and 40. The pattern is that each term increase by the next power of 3.

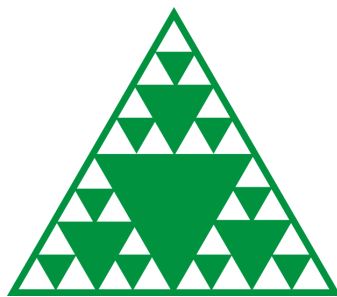

$$\begin{array}{c}
 +3^2 \\
 \curvearrowright \\
 1, 4, 13, 40, \dots \\
 \curvearrowleft \quad \curvearrowright \\
 +3^1 \quad +3^3
 \end{array}$$

Vocabulary

A line segment that connects two midpoints of the sides of a triangle is called a **midsegment**. A **midpoint** is a point that divides a segment into two equal pieces. Two lines are **parallel** if they never intersect. Parallel lines have slopes that are equal. In a triangle, midsegments are always parallel to one side of the triangle.

Guided Practice

The vertices of $\triangle LMN$ are $L(4,5)$, $M(-2,-7)$ and $N(-8,3)$.

1. Find the midpoints of all three sides, label them O , P and Q . Then, graph the triangle, its midpoints and draw in the midsegments.
2. Find the slopes of \overline{NM} and \overline{QO} .
3. Find NM and QO .

4. If the midpoints of the sides of a triangle are $A(1, 5)$, $B(4, -2)$, and $C(-5, 1)$, find the vertices of the triangle.

Answers:

1. Use the midpoint formula 3 times to find all the midpoints.

$$L \text{ and } M = \left(\frac{4+(-2)}{2}, \frac{5+(-7)}{2} \right) = (1, -1), \text{ point } O$$

$$L \text{ and } N = \left(\frac{4+(-8)}{2}, \frac{5+3}{2} \right) = (-2, 4), \text{ point } Q$$

$$M \text{ and } N = \left(\frac{-2+(-8)}{2}, \frac{-7+3}{2} \right) = (-5, -2), \text{ point } P$$

The graph would look like the graph below.

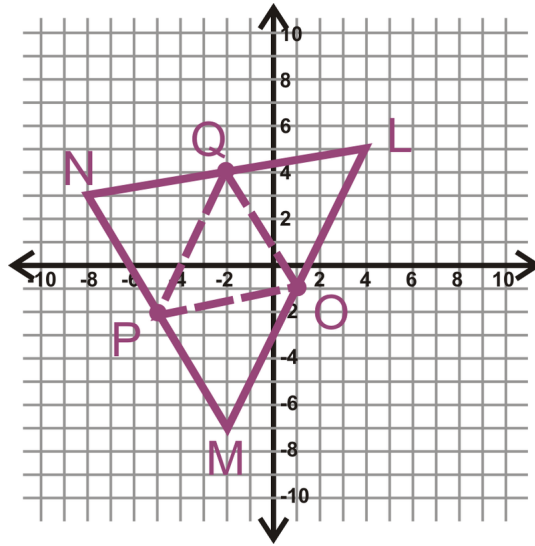

2. The slope of \overline{NM} is $\frac{-7-3}{-2-(-8)} = \frac{-10}{6} = -\frac{5}{3}$.

The slope of \overline{QO} is $\frac{-1-4}{1-(-2)} = -\frac{5}{3}$.

From this we can conclude that $\overline{NM} \parallel \overline{QO}$. If we were to find the slopes of the other sides and midsegments, we would find $\overline{LM} \parallel \overline{QP}$ and $\overline{NL} \parallel \overline{PO}$. **This is a property of all midsegments.**

3. Now, we need to find the lengths of \overline{NM} and \overline{QO} . Use the distance formula.

$$NM = \sqrt{(-7-3)^2 + (-2-(-8))^2} = \sqrt{(-10)^2 + 6^2} = \sqrt{100 + 36} = \sqrt{136} \approx 11.66$$

$$QO = \sqrt{(1-(-2))^2 + (-1-4)^2} = \sqrt{3^2 + (-5)^2} = \sqrt{9 + 25} = \sqrt{34} \approx 5.83$$

Note that QO is **half** of NM .

4. The easiest way to solve this problem is to graph the midpoints and then apply what we know from the Midpoint Theorem.

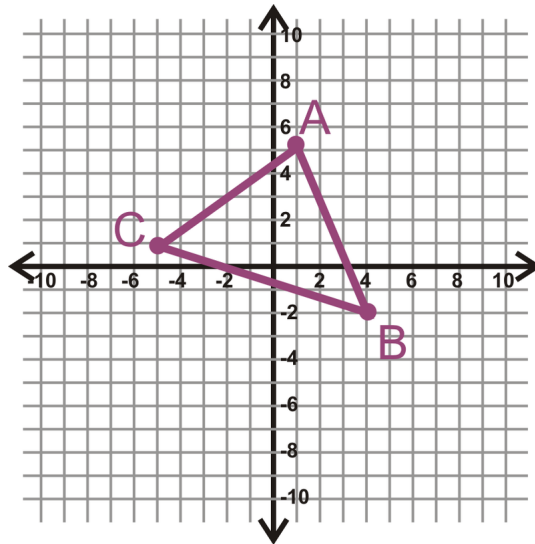

Now that the points are plotted, find the slopes between all three.

$$\text{slope } AB = \frac{5+2}{1-4} = -\frac{7}{3}$$

$$\text{slope } BC = \frac{-2-1}{4+5} = \frac{-3}{9} = -\frac{1}{3}$$

$$\text{slope } AC = \frac{5-1}{1+5} = \frac{4}{6} = \frac{2}{3}$$

Using the slope between two of the points and the third, plot the slope triangle on either side of the third point and extend the line. Repeat this process for all three midpoints. For example, use the slope of AB with point C .

The green lines in the graph to the left represent the slope triangles of each midsegment. The three dotted lines represent the sides of the triangle. Where they intersect are the vertices of the triangle (the blue points), which are $(-8, 8)$, $(10, 2)$ and $(-2, 6)$.

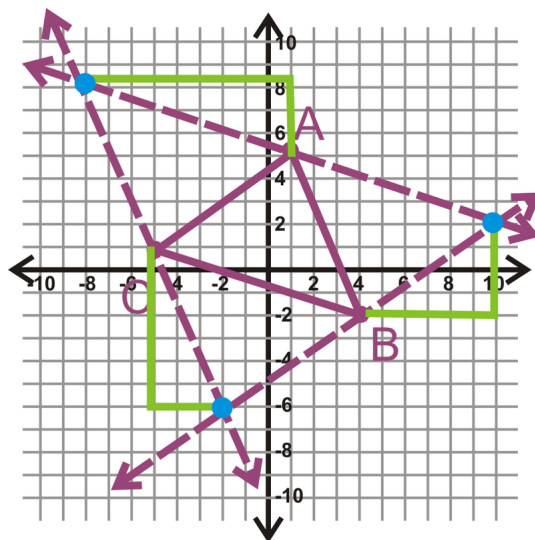

Practice

R, S, T , and U are midpoints of the sides of $\triangle XPO$ and $\triangle YPO$.

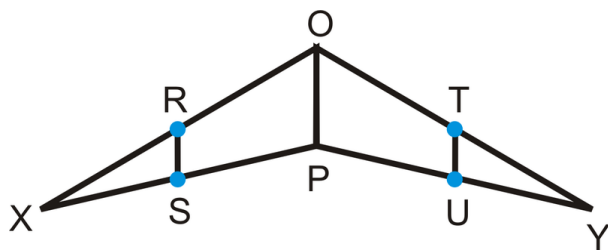

1. If $OP = 12$, find RS and TU .
2. If $RS = 8$, find TU .
3. If $RS = 2x$, and $OP = 20$, find x and TU .
4. If $OP = 4x$ and $RS = 6x - 8$, find x .
5. Is $\triangle XOP \cong \triangle YOP$? Why or why not?

For questions 6-13, find the indicated variable(s). You may assume that all line segments within a triangle are midsegments.

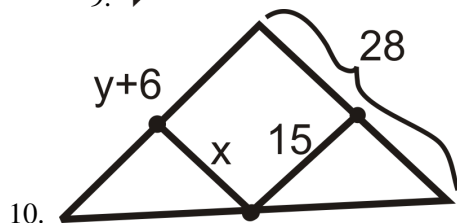
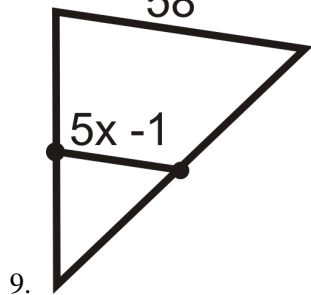
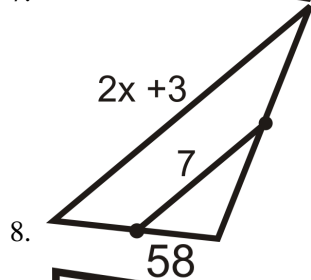
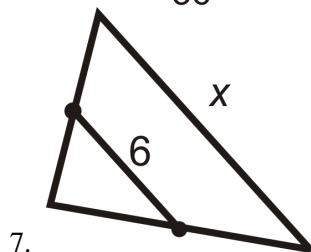
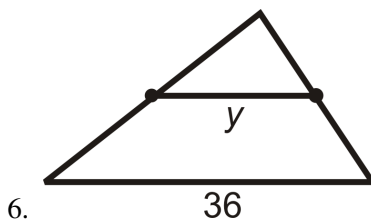

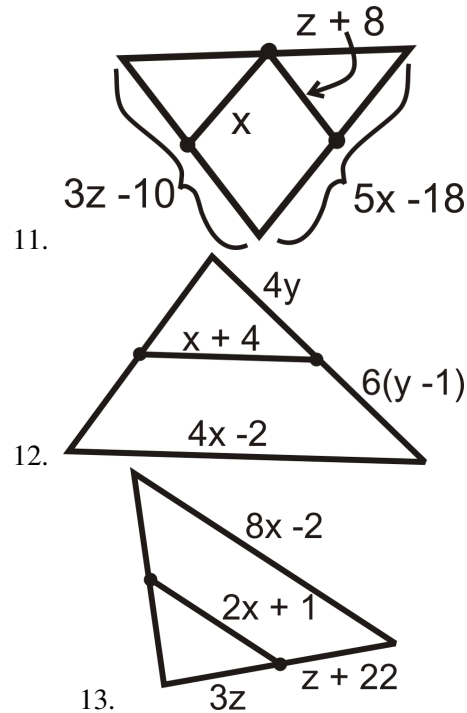

14. The sides of $\triangle XYZ$ are 26, 38, and 42. $\triangle ABC$ is formed by joining the midpoints of $\triangle XYZ$.
- Find the perimeter of $\triangle ABC$.
 - Find the perimeter of $\triangle XYZ$.
 - What is the relationship between the perimeter of a triangle and the perimeter of the triangle formed by connecting its midpoints?

Coordinate Geometry Given the vertices of $\triangle ABC$ below, find the midpoints of each side.

- $A(5, -2)$, $B(9, 4)$ and $C(-3, 8)$
- $A(-10, 1)$, $B(4, 11)$ and $C(0, -7)$
- $A(0, 5)$, $B(4, -1)$ and $C(-2, -3)$
- $A(2, 4)$, $B(8, -4)$ and $C(2, -4)$

For questions 19-22, $\triangle CAT$ has vertices $C(x_1, y_1)$, $A(x_2, y_2)$ and $T(x_3, y_3)$.

- Find the midpoints of sides \overline{CA} and \overline{AT} . Label them L and M respectively.
- Find the slopes of \overline{LM} and \overline{CT} .
- Find the lengths of \overline{LM} and \overline{CT} .
- What have you just proven algebraically?

5.2 Perpendicular Bisectors

Here you'll learn what a perpendicular bisector is and the Perpendicular Bisector Theorem, which states that if a point is on the perpendicular bisector of a segment, then it is equidistant from the endpoints of the segment.

What if an archeologist found three bones in Cairo, Egypt buried 4 meters, 7 meters, and 9 meters apart (to form a triangle)? The likelihood that more bones are in this area is very high. The archeologist wants to dig in an appropriate circle around these bones. If these bones are on the edge of the digging circle, where is the center of the circle? Can you determine how far apart each bone is from the center of the circle? What is this length? After completing this Concept, you'll be able to answer questions like these.

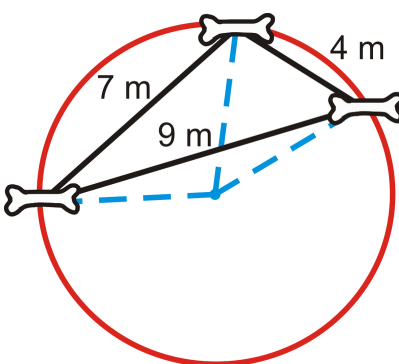

Watch This



MEDIA

Click image to the left for more content.

[CK-12 Foundation: Chapter5PerpendicularBisectorsA](#)

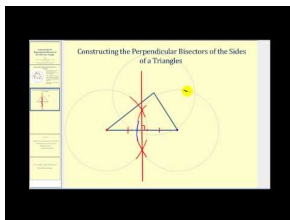

MEDIA

Click image to the left for more content.

[James Sousa:Constructing Perpendicular Bisectors](#)

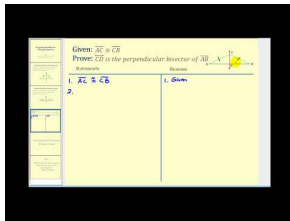

MEDIA

Click image to the left for more content.

James Sousa:Proof of the Perpendicular Bisector Theorem Converse

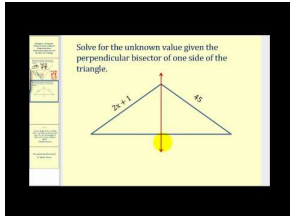

MEDIA

Click image to the left for more content.

James Sousa:Determining Values Using Perpendicular Bisectors

Guidance

Recall that a **perpendicular bisector** intersects a line segment at its midpoint and is perpendicular. Let's analyze this figure.

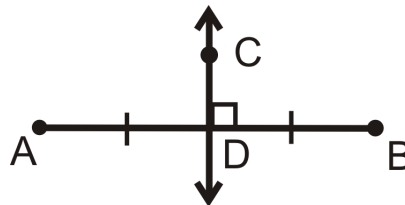

\overleftrightarrow{CD} is the perpendicular bisector of \overline{AB} . If we were to draw in \overline{AC} and \overline{CB} , we would find that they are equal. Therefore, any point on the perpendicular bisector of a segment is the same distance from each endpoint.

Perpendicular Bisector Theorem: If a point is on the perpendicular bisector of a segment, then it is equidistant from the endpoints of the segment.

In addition to the Perpendicular Bisector Theorem, we also know that its converse is true.

Perpendicular Bisector Theorem Converse: If a point is equidistant from the endpoints of a segment, then the point is on the perpendicular bisector of the segment.

Proof of the Perpendicular Bisector Theorem Converse:

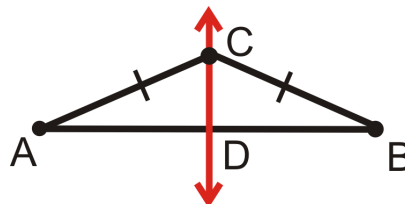

Given: $\overline{AC} \cong \overline{CB}$

Prove: \overleftrightarrow{CD} is the perpendicular bisector of \overline{AB}

TABLE 5.1:

| <i>Statement</i> | <i>Reason</i> |
|--|---|
| 1. $\overline{AC} \cong \overline{CB}$ | Given |
| 2. $\triangle ACB$ is an isosceles triangle | Definition of an isosceles triangle |
| 3. $\angle A \cong \angle B$ | Isosceles Triangle Theorem |
| 4. Draw point D , such that D is the midpoint of \overline{AB} . | Every line segment has exactly one midpoint |
| 5. $\overline{AD} \cong \overline{DB}$ | Definition of a midpoint |
| 6. $\triangle ACD \cong \triangle BCD$ | SAS |
| 7. $\angle CDA \cong \angle CDB$ | CPCTC |
| 8. $m\angle CDA = m\angle CDB = 90^\circ$ | Congruent Supplements Theorem |
| 9. $\overleftrightarrow{CD} \perp \overline{AB}$ | Definition of perpendicular lines |
| 10. \overleftrightarrow{CD} is the perpendicular bisector of \overline{AB} | Definition of perpendicular bisector |

Two lines intersect at a point. If more than two lines intersect at the same point, it is called a **point of concurrency**.

Investigation: Constructing the Perpendicular Bisectors of the Sides of a Triangle

Tools Needed: paper, pencil, compass, ruler

1. Draw a scalene triangle.
2. Construct the perpendicular bisector for all three sides.

The three perpendicular bisectors all intersect at the same point, called the circumcenter.

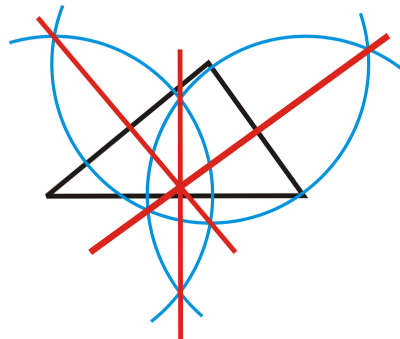

Circumcenter: The point of concurrency for the perpendicular bisectors of the sides of a triangle.

3. Erase the arc marks to leave only the perpendicular bisectors. Put the pointer of your compass on the circumcenter. Open the compass so that the pencil is on one of the vertices. Draw a circle. What happens?

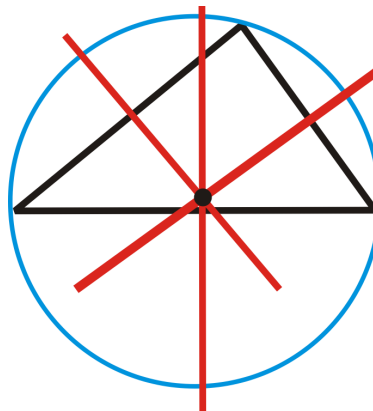

The circumcenter is the center of a circle that passes through all the vertices of the triangle. We say that this circle *circumscribes* the triangle. This means that *the circumcenter is equidistant to the vertices*.

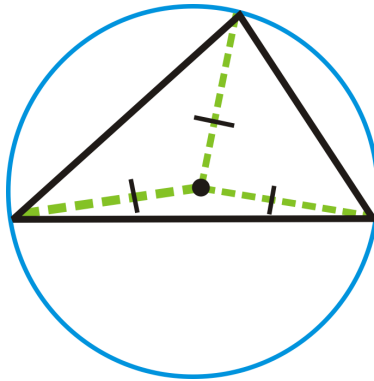

Concurrency of Perpendicular Bisectors Theorem: The perpendicular bisectors of the sides of a triangle intersect in a point that is equidistant from the vertices.

If \overline{PC} , \overline{QC} , and \overline{RC} are perpendicular bisectors, then $LC = MC = OC$.

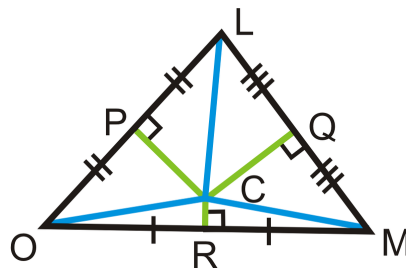

Example A

Find x and the length of each segment.

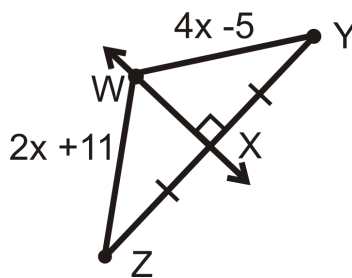

From the markings, we know that \overleftrightarrow{WX} is the perpendicular bisector of \overline{YZ} . Therefore, we can use the Perpendicular Bisector Theorem to conclude that $WZ = WY$. Write an equation.

$$\begin{aligned} 2x + 11 &= 4x - 5 \\ 16 &= 2x \\ 8 &= x \end{aligned}$$

To find the length of WZ and WY , substitute 8 into either expression, $2(8) + 11 = 16 + 11 = 27$.

Example B

\overleftrightarrow{OQ} is the perpendicular bisector of \overline{MP} .

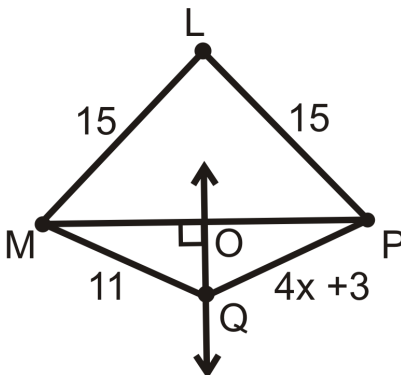

- Which segments are equal?
- Find x .
- Is L on \overleftrightarrow{OQ} ? How do you know?

Answer:

a) $ML = LP$ because they are both 15.

$MO = OP$ because O is the midpoint of \overline{MP}

$MQ = QP$ because Q is on the perpendicular bisector of \overline{MP} .

b)

$$4x + 3 = 11$$

$$4x = 8$$

$$x = 2$$

c) Yes, L is on \overleftrightarrow{OQ} because $ML = LP$ (Perpendicular Bisector Theorem Converse).

Example C

For further exploration, try the following:

- Cut out an acute triangle from a sheet of paper.
- Fold the triangle over one side so that the side is folded in half. Crease.
- Repeat for the other two sides. What do you notice?

The folds (blue dashed lines) are the perpendicular bisectors and cross at the circumcenter.

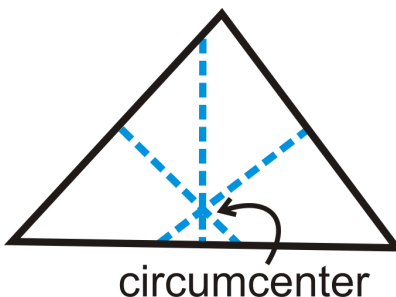

Watch this video for help with the Examples above.



MEDIA

Click image to the left for more content.

[CK-12 Foundation: Chapter5PerpendicularBisectorsB](#)

Concept Problem Revisited

The center of the circle will be the circumcenter of the triangle formed by the three bones. Construct the perpendicular bisector of at least two sides to find the circumcenter. After locating the circumcenter, the archeologist can measure the distance from each bone to it, which would be the radius of the circle. This length is approximately 4.7 meters.

Vocabulary

Perpendicular lines are lines that meet at right (90°) angles. A **midpoint** is the point on a segment that divides the segment into two equal parts. A **perpendicular bisector** is a line that intersects a line segment at its midpoint and is perpendicular to that line segment. When we construct perpendicular bisectors for the sides of a triangle, they meet in one point. This point is called the **circumcenter** of the triangle.

Guided Practice

1. Find the value of x . m is the perpendicular bisector of AB .

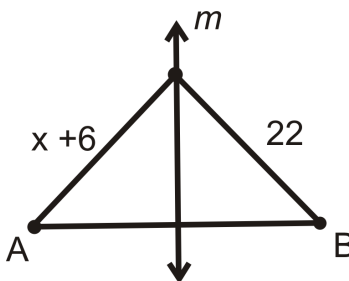

2. Determine if \overleftrightarrow{ST} is the perpendicular bisector of \overline{XY} . Explain why or why not.

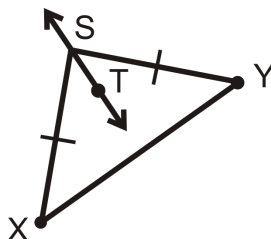

Answers:

1. By the Perpendicular Bisector Theorem, both segments are equal. Set up and solve an equation.

$$x + 6 = 22$$

$$x = 16$$

2. \overleftrightarrow{ST} is not necessarily the perpendicular bisector of \overline{XY} because not enough information is given in the diagram. There is no way to know from the diagram if \overleftrightarrow{ST} will extend to make a right angle with \overline{XY} .

Practice

1. m is the perpendicular bisector of \overline{AB} .
 - a. List all the congruent segments.
 - b. Is C on \overline{AB} ? Why or why not?
 - c. Is D on \overline{AB} ? Why or why not?

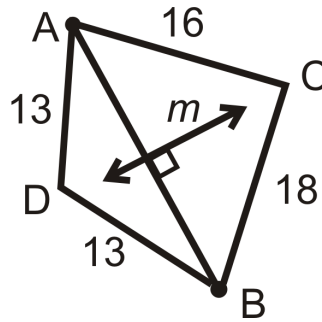

For Question 2, determine if \overleftrightarrow{ST} is the perpendicular bisector of \overline{XY} . Explain why or why not.

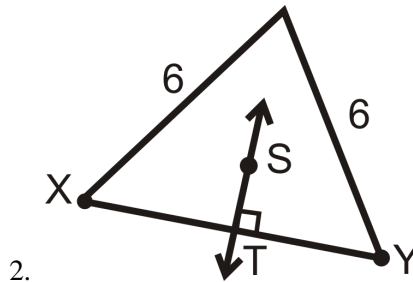

For Questions 3-7, consider line segment \overline{AB} with endpoints $A(2, 1)$ and $B(6, 3)$.

3. Find the slope of AB .
4. Find the midpoint of AB .
5. Find the equation of the perpendicular bisector of AB .
6. Find AB . Simplify the radical, if needed.
7. Plot A, B , and the perpendicular bisector. Label it m . How could you find a point C on m , such that C would be the third vertex of equilateral triangle $\triangle ABC$? *You do not have to find the coordinates, just describe how you would do it.*

For Questions 8-12, consider $\triangle ABC$ with vertices $A(7, 6), B(7, -2)$ and $C(0, 5)$. Plot this triangle on graph paper.

8. Find the midpoint and slope of \overline{AB} and use them to draw the perpendicular bisector of \overline{AB} . You do not need to write the equation.

9. Find the midpoint and slope of \overline{BC} and use them to draw the perpendicular bisector of \overline{BC} . You do not need to write the equation.
10. Find the midpoint and slope of \overline{AC} and use them to draw the perpendicular bisector of \overline{AC} . You do not need to write the equation.
11. Are the three lines concurrent? What are the coordinates of their point of intersection (what is the circumcenter of the triangle)?
12. Use your compass to draw the circumscribed circle about the triangle with your point found in question 11 as the center of your circle.
13. Fill in the blanks: There is exactly _____ circle which contains any _____ points.
14. Fill in the blanks of the proof of the Perpendicular Bisector Theorem.

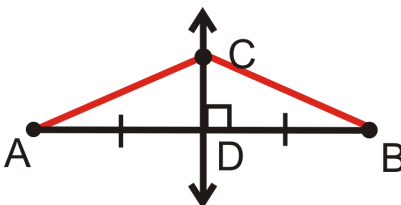

Given: \overleftrightarrow{CD} is the perpendicular bisector of \overline{AB}

Prove: $\overline{AC} \cong \overline{CB}$

TABLE 5.2:

Statement

Reason

- | | |
|---|--------------------------|
| 1. | |
| 2. D is the midpoint of \overline{AB} | |
| 3. | Definition of a midpoint |
| 4. $\angle CDA$ and $\angle CDB$ are right angles | |
| 5. $\angle CDA \cong \angle CDB$ | |
| 6. | Reflexive PoC |
| 7. $\triangle CDA \cong \triangle CDB$ | |
| 8. $\overline{AC} \cong \overline{CB}$ | |
-

15. Write a two column proof.

Given: $\triangle ABC$ is a right isosceles triangle and \overline{BD} is the \perp bisector of \overline{AC}

Prove: $\triangle ABD$ and $\triangle CBD$ are congruent.

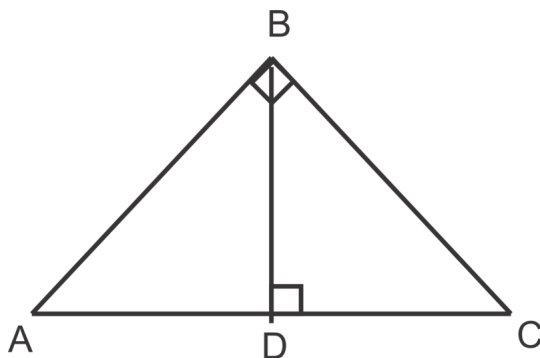

5.3 Angle Bisectors in Triangles

Here you'll learn what an angle bisector is as well as the Angle Bisector Theorem, which states that if a point is on the bisector of an angle, then the point is equidistant from the sides of the angle.

What if the cities of Verticville, Triopolis, and Angletown were joining their city budgets together to build a centrally located airport? There are freeways between the three cities and they want to have the freeway on the interior of these freeways. Where is the best location to put the airport so that they have to build the least amount of road? In the picture below, the blue lines are the proposed roads. After completing this Concept, you'll be able to use angle bisectors to help answer this question.

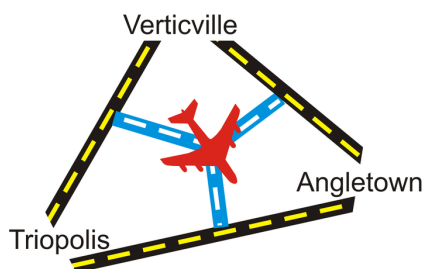

Watch This



MEDIA

Click image to the left for more content.

[CK-12 Foundation: Chapter5AngleBisectorsA](#)

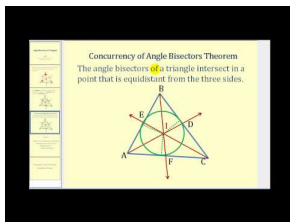

MEDIA

Click image to the left for more content.

[James Sousa:Introduction toAngle Bisectors](#)

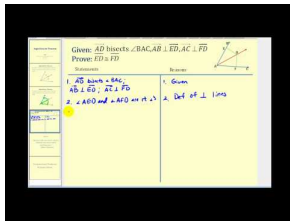

MEDIA
 Click image to the left for more content.

James Sousa:Proof of the Angle Bisector Theorem

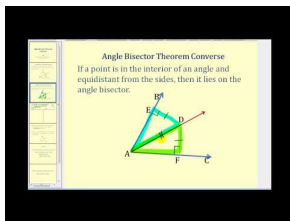

MEDIA
 Click image to the left for more content.

James Sousa:Proof of the Angle Bisector Theorem Converse

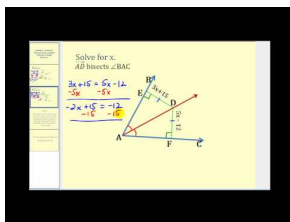

MEDIA
 Click image to the left for more content.

James Sousa:Solving For Unknown Values Using Angle Bisectors

Guidance

Recall that an **angle bisector** cuts an angle exactly in half. Let's analyze this figure.

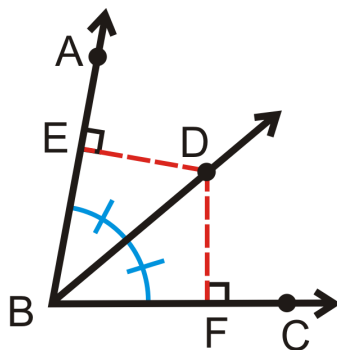

\overrightarrow{BD} is the angle bisector of $\angle ABC$. Looking at point D , if we were to draw \overline{ED} and \overline{DF} , we would find that they are equal. Recall that the shortest distance from a point to a line is the perpendicular length between them. ED and DF are the shortest lengths between D , which is on the angle bisector, and each side of the angle.

Angle Bisector Theorem: If a point is on the bisector of an angle, then the point is equidistant from the sides of the angle.

In other words, if \overrightarrow{BD} bisects $\angle ABC$, $\overline{BE} \perp \overline{ED}$, and $\overline{BF} \perp \overline{DF}$, then $ED = DF$.

Proof of the Angle Bisector Theorem:

Given: \overrightarrow{BD} bisects $\angle ABC$, $\overrightarrow{BA} \perp \overrightarrow{AD}$, and $\overrightarrow{BC} \perp \overrightarrow{DC}$

Prove: $\overline{AD} \cong \overline{DC}$

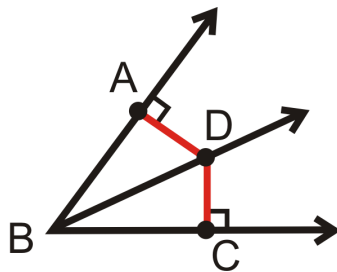

TABLE 5.3:

| Statement | Reason |
|---|-----------------------------------|
| 1. \overrightarrow{BD} bisects $\angle ABC$, $\overrightarrow{BA} \perp \overrightarrow{AD}$, $\overrightarrow{BC} \perp \overrightarrow{DC}$ | Given |
| 2. $\angle ABD \cong \angle DBC$ | Definition of an angle bisector |
| 3. $\angle DAB$ and $\angle DCB$ are right angles | Definition of perpendicular lines |
| 4. $\angle DAB \cong \angle DCB$ | All right angles are congruent |
| 5. $\overline{BD} \cong \overline{BD}$ | Reflexive PoC |
| 6. $\triangle ABD \cong \triangle CBD$ | AAS |
| 7. $\overline{AD} \cong \overline{DC}$ | CPCTC |

The converse of this theorem is also true.

Angle Bisector Theorem Converse: If a point is in the interior of an angle and equidistant from the sides, then it lies on the bisector of the angle.

Because the Angle Bisector Theorem and its converse are both true we have a biconditional statement. We can put the two conditional statements together using if and only if. *A point is on the angle bisector of an angle if and only if it is equidistant from the sides of the triangle.* Like perpendicular bisectors, the point of concurrency for angle bisectors has interesting properties.

Investigation: Constructing Angle Bisectors in Triangles

Tools Needed: compass, ruler, pencil, paper

1. Draw a scalene triangle. Construct the angle bisector of each angle. Use Investigation 1-4 and #1 from the Review Queue to help you.

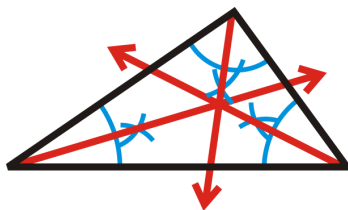

Incenter: The point of concurrency for the angle bisectors of a triangle.

2. Erase the arc marks and the angle bisectors after the incenter. Draw or construct the perpendicular lines to each side, through the incenter.

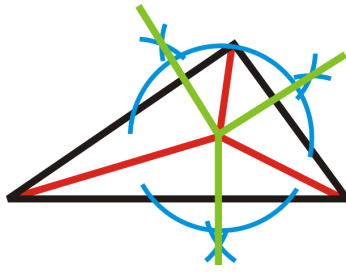

3. Erase the arc marks from #2 and the perpendicular lines beyond the sides of the triangle. Place the pointer of the compass on the incenter. Open the compass to intersect one of the three perpendicular lines drawn in #2. Draw a circle.



Notice that the circle touches all three sides of the triangle. We say that this circle is *inscribed* in the triangle because it touches all three sides. The incenter is on all three angle bisectors, so *the incenter is equidistant from all three sides of the triangle*.

Concurrency of Angle Bisectors Theorem: The angle bisectors of a triangle intersect in a point that is equidistant from the three sides of the triangle.

If \overline{AG} , \overline{BG} , and \overline{CG} are the angle bisectors of the angles in the triangle, then $EG = FG = GD$.

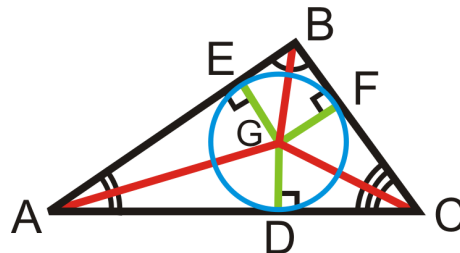

In other words, \overline{EG} , \overline{FG} , and \overline{DG} are the radii of the inscribed circle.

Example A

Is Y on the angle bisector of $\angle XWZ$?

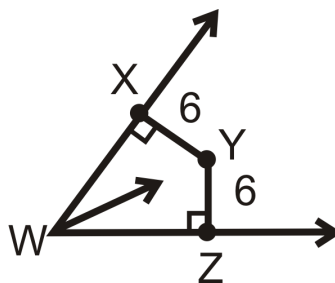

In order for Y to be on the angle bisector XY needs to be equal to YZ and they both need to be perpendicular to the sides of the angle. From the markings we know $\overline{XY} \perp \overline{WX}$ and $\overline{YZ} \perp \overline{WZ}$. Second, $XY = YZ = 6$. From this we can conclude that Y is on the angle bisector.

Example B

If $J, E,$ and G are midpoints and $KA = AD = AH$ what are points A and B called?

A is the incenter because $KA = AD = AH$, which means that it is equidistant to the sides. B is the circumcenter because $\overline{JB}, \overline{BE},$ and \overline{BG} are the perpendicular bisectors to the sides.

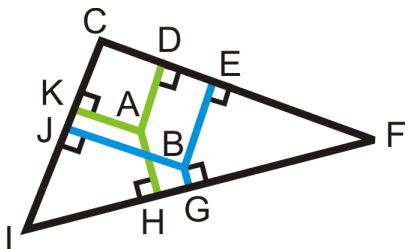

Example C

\overrightarrow{AB} is the angle bisector of $\angle CAD$. Solve for the missing variable.

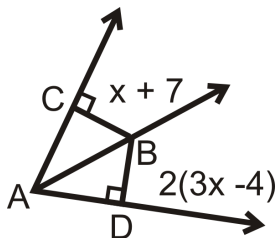

$CB = BD$ by the Angle Bisector Theorem, so we can set up and solve an equation for x .

$$\begin{aligned}
 x + 7 &= 2(3x - 4) \\
 x + 7 &= 6x - 8 \\
 15 &= 5x \\
 x &= 3
 \end{aligned}$$

Watch this video for help with the Examples above.



MEDIA

Click image to the left for more content.

[CK-12 Foundation: Chapter5AngleBisectorsB](#)

Concept Problem Revisited

The airport needs to be equidistant to the three highways between the three cities. Therefore, the roads are all perpendicular to each side and congruent. The airport should be located at the incenter of the triangle.

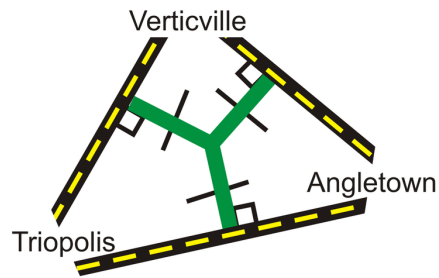

Vocabulary

An *angle bisector* cuts an angle exactly in half. *Equidistant* means the same distance from. A point is equidistant from two lines if it is the same distance from both lines. When we construct angle bisectors for the angles of a triangle, they meet in one point. This point is called the *incenter* of the triangle.

Guided Practice

1. Is there enough information to determine if \overrightarrow{AB} is the angle bisector of $\angle CAD$? Why or why not?

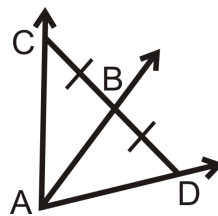

2. \overrightarrow{MO} is the angle bisector of $\angle LMN$. Find the measure of x .

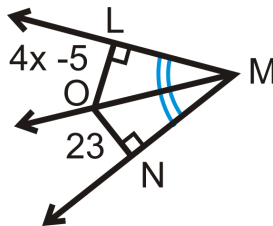

3. A 100° angle is bisected. What are the measures of the resulting angles?

Answers:

1. No because B is not necessarily equidistant from \overline{AC} and \overline{AD} . We do not know if the angles in the diagram are right angles.
2. $LO = ON$ by the Angle Bisector Theorem.

$$\begin{aligned} 4x - 5 &= 23 \\ 4x &= 28 \\ x &= 7 \end{aligned}$$

3. We know that to bisect means to cut in half, so each of the resulting angles will be half of 100. The measure of each resulting angle is 50° .

Practice

For questions 1-6, \overrightarrow{AB} is the angle bisector of $\angle CAD$. Solve for the missing variable.

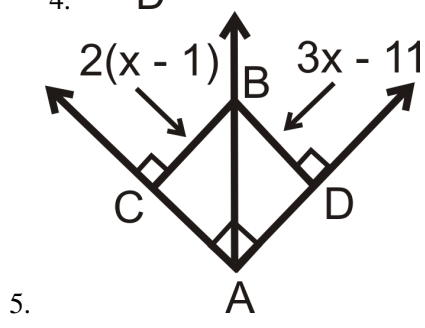
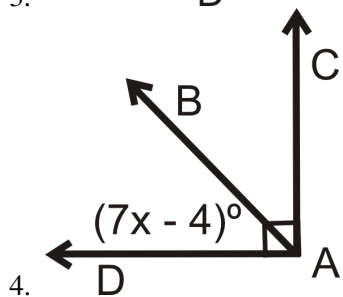
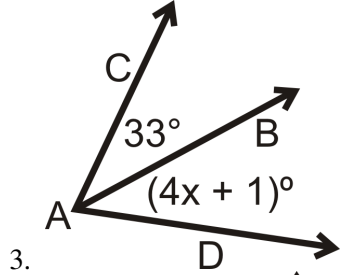
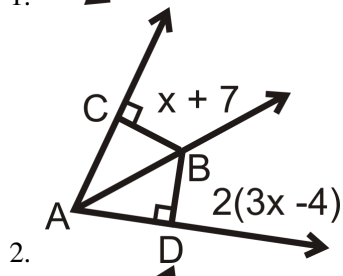
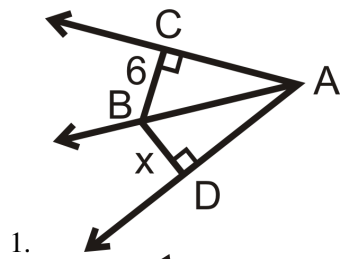

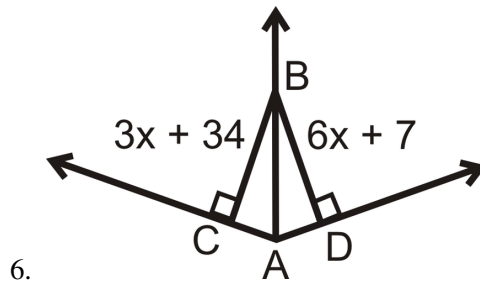

Is there enough information to determine if \vec{AB} is the angle bisector of $\angle CAD$? Why or why not?

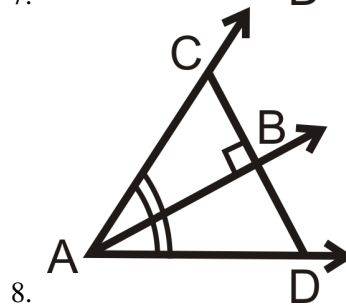
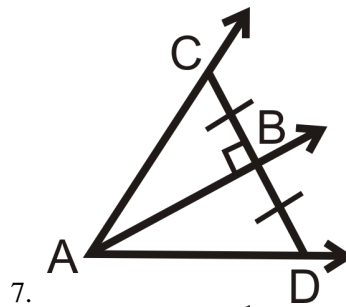

9. Fill in the blanks in the Angle Bisector Theorem Converse.

Given: $\overline{AD} \cong \overline{DC}$, such that AD and DC are the shortest distances to \vec{BA} and \vec{BC}

Prove: \vec{BD} bisects $\angle ABC$

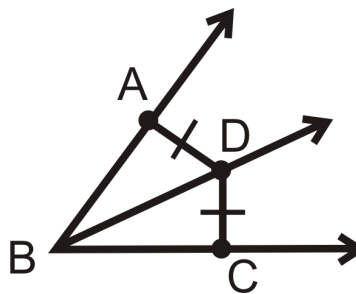

TABLE 5.4:

Statement

- 1.
- 2.
3. $\angle DAB$ and $\angle DCB$ are right angles
4. $\angle DAB \cong \angle DCB$
5. $\overline{BD} \cong \overline{BD}$

Reason

The shortest distance from a point to a line is perpendicular.

TABLE 5.4: (continued)

| <i>Statement</i> | <i>Reason</i> |
|---|---------------|
| 6. $\triangle ABD \cong \triangle CBD$ | |
| 7. | CPCTC |
| 8. \overrightarrow{BD} bisects $\angle ABC$ | |

Determine if the following descriptions refer to the incenter or circumcenter of the triangle.

10. A lighthouse on a triangular island is equidistant to the three coastlines.
11. A hospital is equidistant to three cities.
12. A circular walking path passes through three historical landmarks.
13. A circular walking path connects three other straight paths.

Multi- Step Problem

14. Draw $\angle ABC$ through $A(1,3)$, $B(3,-1)$ and $C(7,1)$.
15. Use slopes to show that $\angle ABC$ is a right angle.
16. Use the distance formula to find AB and BC .
17. Construct a line perpendicular to AB through A .
18. Construct a line perpendicular to BC through C .
19. These lines intersect in the interior of $\angle ABC$. Label this point D and draw \overrightarrow{BD} .
20. Is \overrightarrow{BD} the angle bisector of $\angle ABC$? Justify your answer.

5.4 Medians

Here you'll learn the definitions of median and centroid and how to apply them.

What if your art teacher assigned an art project involving triangles? You decide to make a series of hanging triangles of all different sizes from one long piece of wire. Where should you hang the triangles from so that they balance horizontally?

You decide to plot one triangle on the coordinate plane to find the location of this point. The coordinates of the vertices are $(0, 0)$, $(6, 12)$ and $(18, 0)$. What is the coordinate of this point? After completing this Concept, you'll be able to use medians to help you answer these questions.

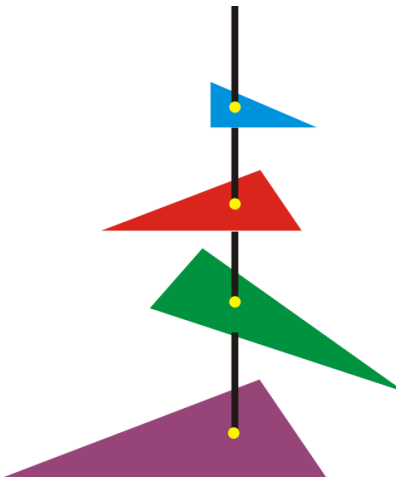

Watch This



MEDIA

Click image to the left for more content.

CK-12 Foundation: Chapter5MediansA

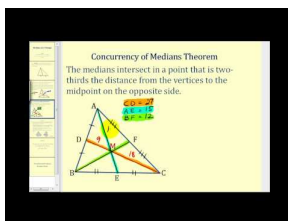

MEDIA

Click image to the left for more content.

James Sousa:Medians of a Triangle

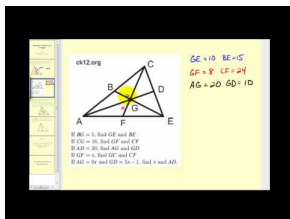

MEDIA

Click image to the left for more content.

James Sousa:Using the Properties of Mediansto Solve for Unknown Values

Guidance

A **median** is the line segment that joins a vertex and the midpoint of the opposite side (of a triangle). The three medians of a triangle intersect at one point, just like the perpendicular bisectors and angle bisectors. This point is called the **centroid**, and is the point of concurrency for the medians of a triangle. Unlike the circumcenter and incenter, the centroid does not have anything to do with circles. It has a different property.

Investigation: Properties of the Centroid

Tools Needed: pencil, paper, ruler, compass

1. Construct a scalene triangle with sides of length 6 cm, 10 cm, and 12 cm (Investigation 4-2). Use the ruler to measure each side and mark the midpoint.

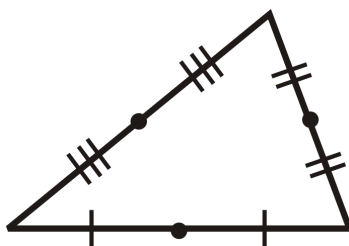

2. Draw in the medians and mark the centroid.

Measure the length of each median. Then, measure the length from each vertex to the centroid and from the centroid to the midpoint. Do you notice anything?

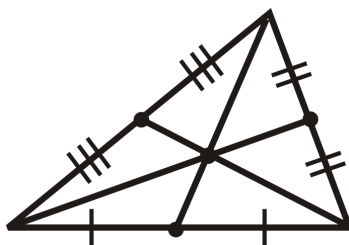

3. Cut out the triangle. Place the centroid on either the tip of the pencil or the pointer of the compass. What happens?

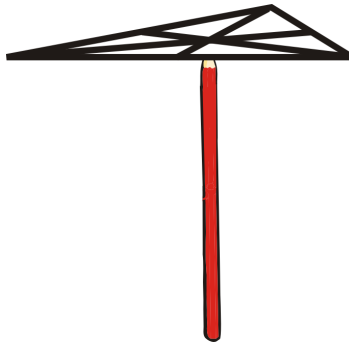

From this investigation, we have discovered the properties of the centroid. They are summarized below.

Concurrency of Medians Theorem: The medians of a triangle intersect in a point that is two-thirds of the distance from the vertices to the midpoint of the opposite side. The centroid is also the “balancing point” of a triangle.

If G is the centroid, then we can conclude:

$$AG = \frac{2}{3}AD, CG = \frac{2}{3}CF, EG = \frac{2}{3}BE$$

$$DG = \frac{1}{3}AD, FG = \frac{1}{3}CF, BG = \frac{1}{3}BE$$

And, combining these equations, we can also conclude:

$$DG = \frac{1}{2}AG, FG = \frac{1}{2}CG, BG = \frac{1}{2}EG$$

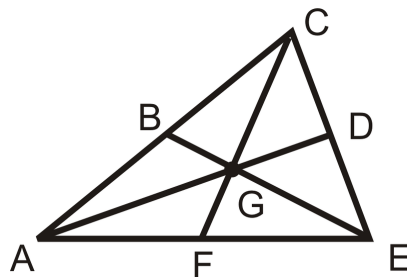

In addition to these ratios, G is also the balance point of $\triangle ACE$. This means that the triangle will balance when placed on a pencil at this point.

Example A

Draw the median \overline{LO} for $\triangle LMN$ below.

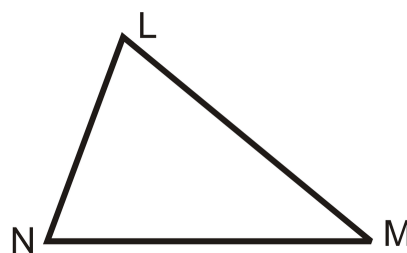

From the definition, we need to locate the midpoint of \overline{NM} . We were told that the median is \overline{LO} , which means that it will connect the vertex L and the midpoint of \overline{NM} , to be labeled O . Measure NM and make a point halfway between N and M . Then, connect O to L .

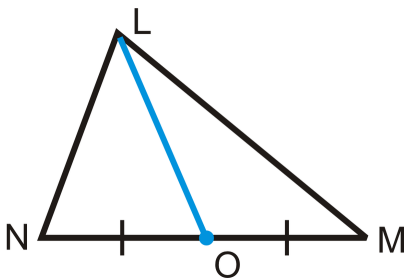

Example B

Find the other two medians of $\triangle LMN$.

Repeat the process from Example A for sides \overline{LN} and \overline{LM} . Be sure to always include the appropriate tick marks to indicate midpoints.

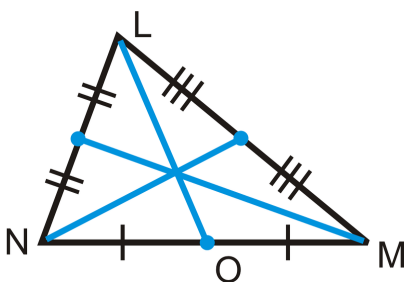

Example C

I , K , and M are midpoints of the sides of $\triangle HJL$.

- If $JM = 18$, find JN and NM .
- If $HN = 14$, find NK and NK .

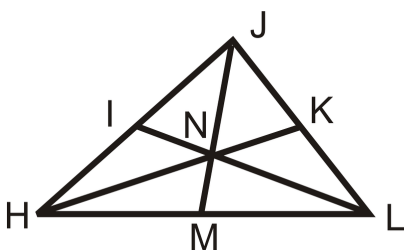

- JN is two-thirds of JM . So, $JN = \frac{2}{3} \cdot 18 = 12$. NM is either half of 12, a third of 18 or $18 - 12$. $NM = 6$.
- HN is two-thirds of HK . So, $14 = \frac{2}{3} \cdot HK$ and $HK = 14 \cdot \frac{3}{2} = 21$. NK is a third of 21, half of 14, or $21 - 14$. $NK = 7$.

Watch this video for help with the Examples above.



MEDIA

Click image to the left for more content.

CK-12 Foundation: Chapter5MediansB

Concept Problem Revisited

The point that you should put the wire through is the centroid. That way, each triangle will balance on the wire.

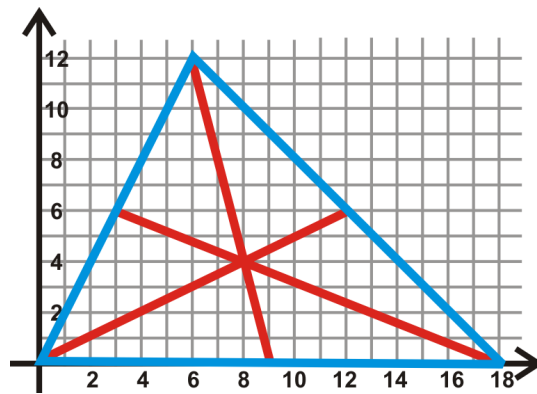

The triangle that we wanted to plot on the $x - y$ plane is to the right. Drawing all the medians, it looks like the centroid is $(8, 4)$. To verify this, you could find the equation of two medians and set them equal to each other and solve for x . Two equations are $y = \frac{1}{2}x$ and $y = -4x + 36$. Setting them equal to each other, we find that $x = 8$ and then $y = 4$.

Vocabulary

A **median** is the line segment that joins a vertex and the midpoint of the opposite side in a triangle. A **midpoint** is a point that divides a segment into two equal pieces. A **centroid** is the point of intersection for the medians of a triangle.

Guided Practice

1. Find the equation of the median from B to the midpoint of \overline{AC} for the triangle in the $x - y$ plane below.

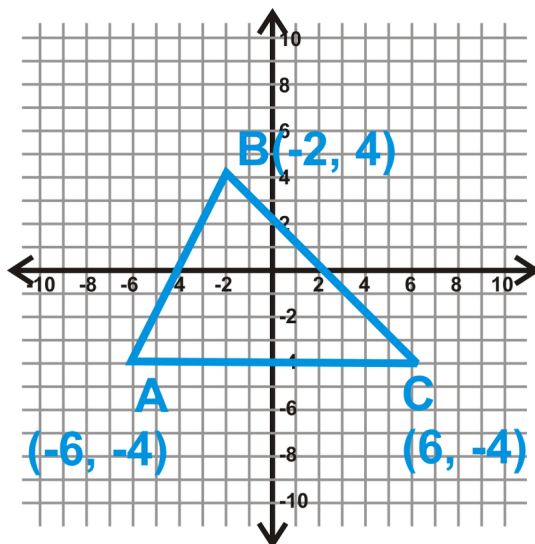

2. H is the centroid of $\triangle ABC$ and $DC = 5y - 16$. Find x and y .

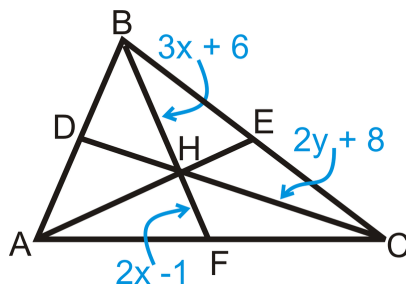

3. True or false: The median bisects the side it intersects.

Answers:

1. To find the equation of the median, first we need to find the midpoint of \overline{AC} , using the Midpoint Formula.

$$\left(\frac{-6+6}{2}, \frac{-4+(-4)}{2} \right) = \left(\frac{0}{2}, \frac{-8}{2} \right) = (0, -4)$$

Now, we have two points that make a line, B and the midpoint. Find the slope and y -intercept.

$$m = \frac{-4 - 4}{0 - (-2)} = \frac{-8}{2} = -4$$

$$y = -4x + b$$

$$-4 = -4(0) + b$$

$$-4 = b$$

The equation of the median is $y = -4x - 4$

2. HF is half of BH . Use this information to solve for x . For y , HC is two-thirds of DC . Set up an equation for both.

$$\frac{1}{2}BH = HF \text{ or } BH = 2HF$$

$$3x + 6 = 2(2x - 1)$$

$$3x + 6 = 4x - 2$$

$$8 = x$$

$$HC = \frac{2}{3}DC \text{ or } \frac{3}{2}HC = DC$$

$$\frac{3}{2}(2y + 8) = 5y - 16$$

$$3y + 12 = 5y - 16$$

$$28 = 2y$$

3. This statement is true. By definition, a median intersects a side of a triangle at its midpoint. Midpoints divide segments into two equal parts.

Practice

For questions 1-4, find the equation of each median, from vertex A to the opposite side, \overline{BC} .

1. $A(9, 5), B(2, 5), C(4, 1)$
2. $A(-2, 3), B(-3, -7), C(5, -5)$
3. $A(-1, 5), B(0, -1), C(6, 3)$
4. $A(6, -3), B(-5, -4), C(-1, -8)$

For questions 5-9, $B, D,$ and F are the midpoints of each side and G is the centroid. Find the following lengths.

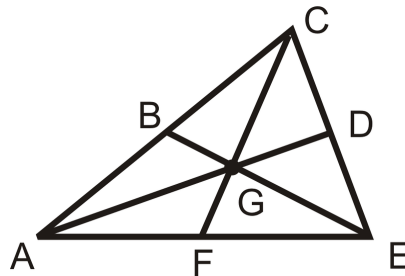

5. If $BG = 5$, find GE and BE
6. If $CG = 16$, find GF and CF
7. If $AD = 30$, find AG and GD
8. If $GF = x$, find GC and CF
9. If $AG = 9x$ and $GD = 5x - 1$, find x and AD .

Use $\triangle ABC$ with $A(-2, 9), B(6, 1)$ and $C(-4, -7)$ for questions 10-15.

10. Find the midpoint of \overline{AB} and label it M .
11. Write the equation of \overleftrightarrow{CM} .
12. Find the midpoint of \overline{BC} and label it N .
13. Write the equation of \overleftrightarrow{AN} .
14. Find the intersection of \overleftrightarrow{CM} and \overleftrightarrow{AN} .
15. What is this point called?

Another way to find the centroid of a triangle in the coordinate plane is to find the midpoint of one side and then find the point two thirds of the way from the third vertex to this point. To find the point two thirds of the way from point $A(x_1, y_1)$ to $B(x_2, y_2)$ use the formula: $\left(\frac{x_1 + 2x_2}{3}, \frac{y_1 + 2y_2}{3}\right)$. Use this method to find the centroid in the following problems.

16. $(-1, 3)$, $(5, -2)$ and $(-1, -4)$
17. $(1, -2)$, $(-5, 4)$ and $(7, 7)$
18. $(2, -7)$, $(-5, 1)$ and $(6, -9)$

5.5 Altitudes

Here you'll learn the definition of altitude and how to determine where a triangle's altitude will be found.

What if you were given one or more of a triangle's angle measures? How would you determine where the triangle's altitude would be found? After completing this Concept, you'll be able to answer this type of question.

Watch This



MEDIA

Click image to the left for more content.

[CK-12 Foundation: Chapter5AltitudesA](#)

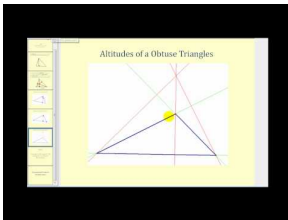

MEDIA

Click image to the left for more content.

[James Sousa:Altitudes of a Triangle](#)

Guidance

An **altitude** is a line segment in a triangle from a vertex and perpendicular to the opposite side, it is also known as the height of a triangle. All of the red lines are examples of altitudes:



As you can see, an altitude can be a side of a triangle or outside of the triangle. When a triangle is a right triangle, the altitude, or height, is the leg. To construct an altitude, construct a perpendicular line through a point not on the given line. Think of the vertex as the point and the given line as the opposite side.

Investigation: Constructing an Altitude for an Obtuse Triangle

Tools Needed: pencil, paper, compass, ruler

1. Draw an obtuse triangle. Label it $\triangle ABC$, like the picture to the right. Extend side \overline{AC} , beyond point A.

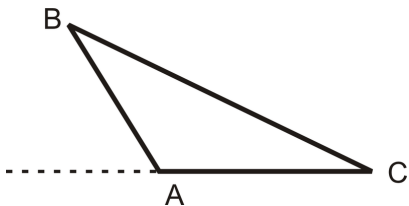

2. Construct a perpendicular line to \overline{AC} , through B.

The altitude does not have to extend past side \overline{AC} , as it does in the picture. Technically the height is only the vertical distance from the highest vertex to the opposite side.

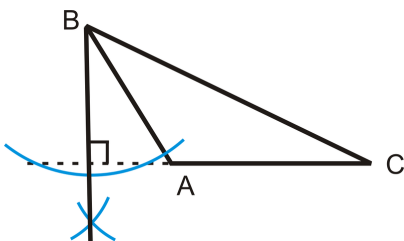

As was true with perpendicular bisectors, angle bisectors, and medians, the altitudes of a triangle are also concurrent. Unlike the other three, the point does not have any special properties.

Orthocenter: The point of concurrency for the altitudes of triangle.

Here is what the orthocenter looks like for the three triangles. It has three different locations, much like the perpendicular bisectors.

TABLE 5.5:

Acute Triangle

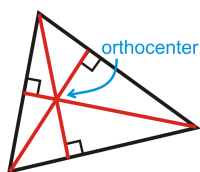

The orthocenter is inside the triangle.

Right Triangle

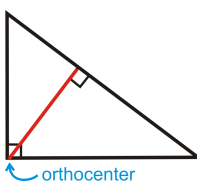

The legs of the triangle are two of the altitudes. The orthocenter is the vertex of the right angle.

Obtuse Triangle

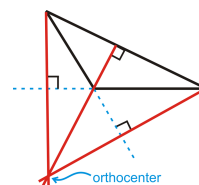

The orthocenter is outside the triangle.

Example A

Which line segment is an altitude of $\triangle ABC$?

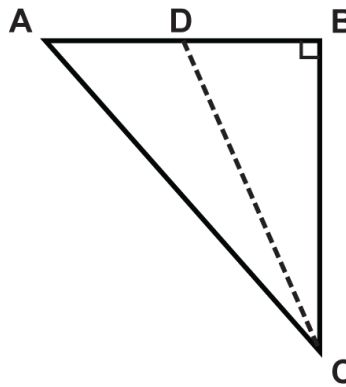

In a right triangle, the altitude, or the height, is the leg. If we rotate the triangle so that the right angle is in the lower left corner, we see that leg BC is an altitude.

Example B

A triangle has angles that measure 55° , 60° , and 65° . Where will the orthocenter be found?

Because all of the angle measures are less than 90° , the triangle is an acute triangle. The orthocenter of any acute triangle is inside the triangle.

Example C

A triangle has an angle that measures 95° . Where will the orthocenter be found?

Because $95^\circ > 90^\circ$, the triangle is an obtuse triangle. The orthocenter will be outside the triangle.

Watch this video for help with the Examples above.



MEDIA

Click image to the left for more content.

[CK-12 Foundation: Chapter5AltitudesB](#)

Vocabulary

The **altitude** of a triangle, also known as the height, is a line segment from a vertex and perpendicular to the opposite side. **Perpendicular** lines are lines that meet at right (90°) angles. The **orthocenter** of a triangle is the point of concurrency for the altitudes of triangle (the point where all of the altitudes meet).

Guided Practice

1. True or false: The altitudes of an obtuse triangle are inside the triangle.
2. Draw the altitude for the triangle shown.

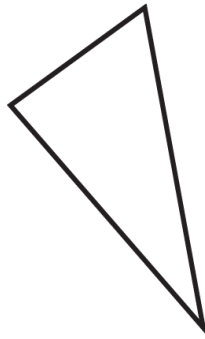

3. Draw the altitude for the triangle shown.

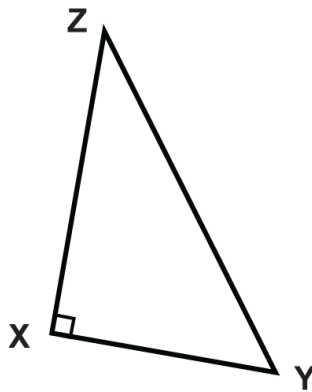

Answers:

1. Every triangle has three altitudes. For an obtuse triangle, at least one of the altitudes will be outside of the triangle, as shown in the picture at the beginning of this concept.
2. The triangle is an acute triangle, so the altitude is inside the triangle as shown below so that it is perpendicular to the base.

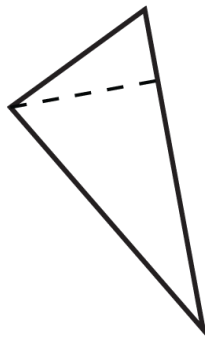

3. The triangle is a right triangle, so the altitude is already drawn. The altitude is \overline{XZ} .

Practice

Write a two-column proof.

1. Given: Isosceles $\triangle ABC$ with legs \overline{AB} and \overline{AC} , $\overline{BD} \perp \overline{AC}$ and $\overline{CE} \perp \overline{AB}$. Prove: $\overline{BD} \cong \overline{CE}$

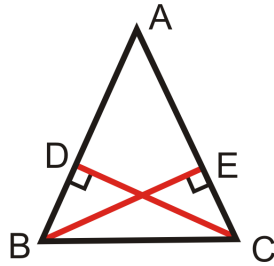

For the following triangles, will the altitudes be inside the triangle, outside the triangle, or at the leg of the triangle?

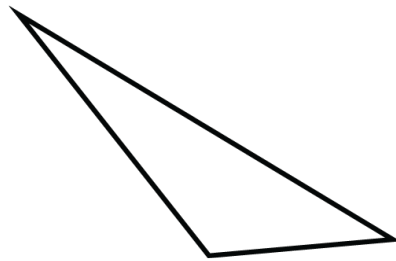

2.

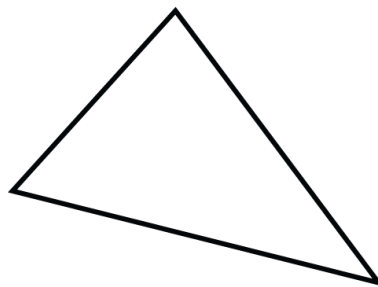

3.

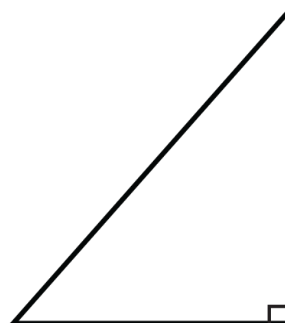

4.

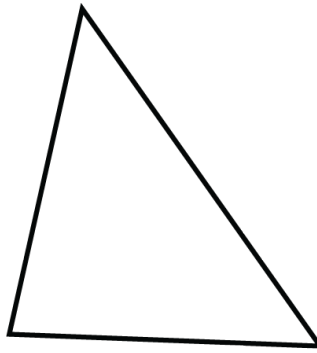

5.

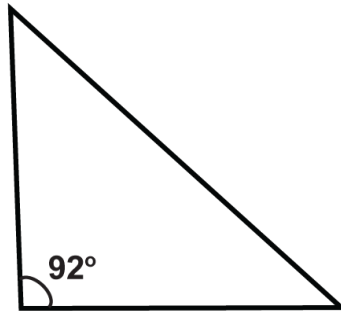

6.

- 7. $\triangle JKL$ is an equiangular triangle.
- 8. $\triangle MNO$ is a triangle in which two the angles measure 30° and 60° .
- 9. $\triangle PQR$ is an isosceles triangle in which two of the angles measure 25° .
- 10. $\triangle STU$ is an isosceles triangle in which two angles measures 45° .

Given the following triangles, which line segment is the altitude?

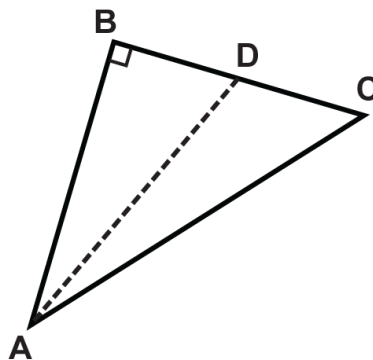

11.

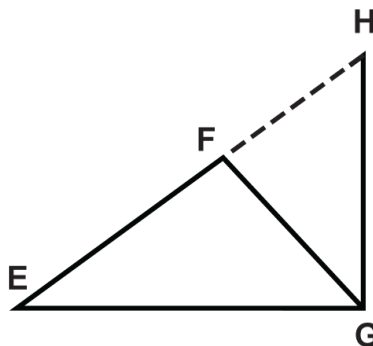

12.

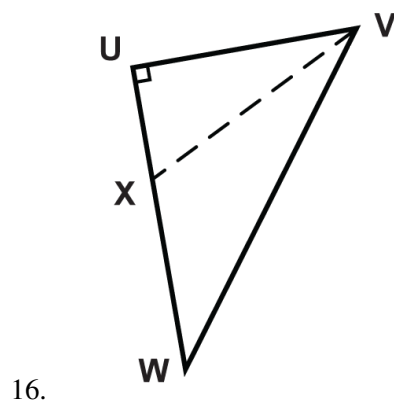
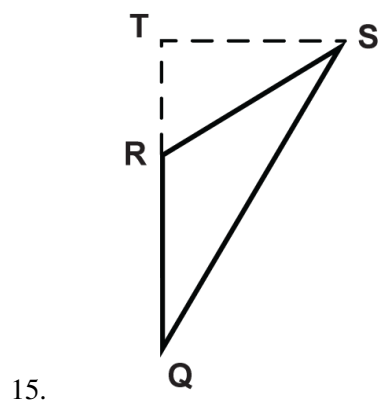
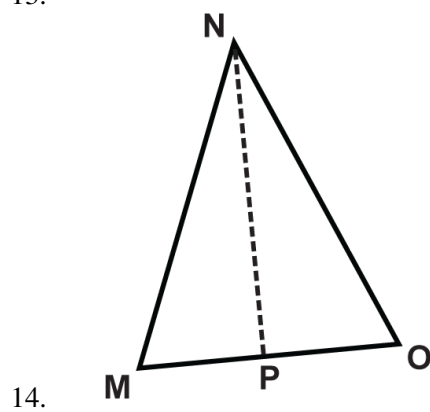
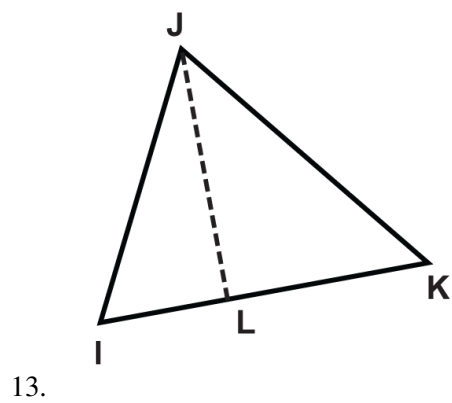

5.6 Comparing Angles and Sides in Triangles

Here you'll learn how to compare sides and angles in triangles. Specifically, you'll learn how to order the angles of a triangle from largest to smallest based on the length of their opposite sides.

What if two mountain bikers leave from the same parking lot and head in opposite directions on two different trails? The first rider goes 8 miles due west, then rides due south for 15 miles. The second rider goes 6 miles due east, then changes direction and rides 20° east of due north for 17 miles. Both riders have been traveling for 23 miles, but which one is further from the parking lot? After completing this Concept, you will be able to compare triangles in order to answer questions like this one.

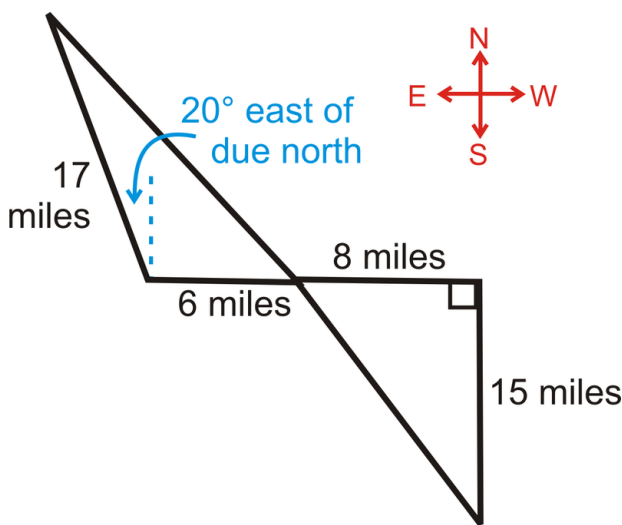

Watch This



MEDIA
Click image to the left for more content.

CK-12 Foundation: Chapter5ComparingAnglesandSidesA

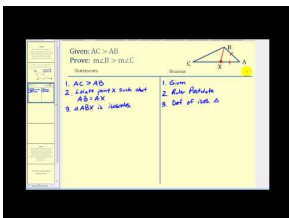

MEDIA
Click image to the left for more content.

James Sousa:Proof that the Angle of a Triangle Opposite the Longest Side is the Largest Angle

Guidance

Look at the triangle below. The sides of the triangle are given. Can you determine which angle is the largest? As you might guess, the largest angle will be opposite 18 because it is the longest side. Similarly, the smallest angle will be opposite the shortest side, 7. Therefore, the angle measure in the middle will be opposite 13.

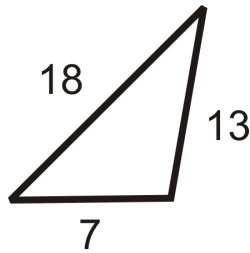

Theorem: If one side of a triangle is longer than another side, then the angle opposite the longer side will be larger than the angle opposite the shorter side.

Converse: If one angle in a triangle is larger than another angle in a triangle, then the side opposite the larger angle will be longer than the side opposite the smaller angle.

Proof of Theorem:

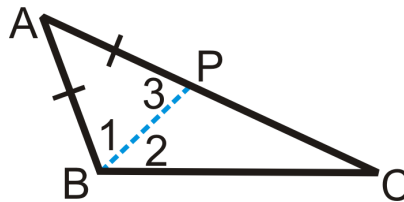

Given: $AC > AB$

Prove: $m\angle ABC > m\angle C$

TABLE 5.6:

| <i>Statement</i> | <i>Reason</i> |
|--|--|
| 1. $AC > AB$ | Given |
| 2. Locate point P such that $AB = AP$ | Ruler Postulate |
| 3. $\triangle ABP$ is an isosceles triangle | Definition of an isosceles triangle |
| 4. $m\angle 1 = m\angle 3$ | Base Angles Theorem |
| 5. $m\angle 3 = m\angle 2 + m\angle C$ | Exterior Angle Theorem |
| 6. $m\angle 1 = m\angle 2 + m\angle C$ | Substitution PoE |
| 7. $m\angle ABC = m\angle 1 + m\angle 2$ | Angle Addition Postulate |
| 8. $m\angle ABC = m\angle 2 + m\angle 2 + m\angle C$ | Substitution PoE |
| 9. $m\angle ABC > m\angle C$ | Definition of “greater than” (from step 8) |

We have two congruent triangles $\triangle ABC$ and $\triangle DEF$, marked below:

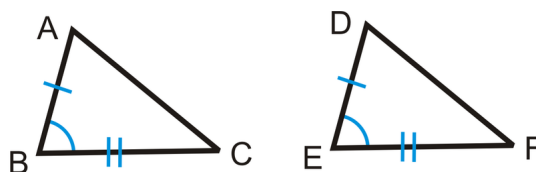

Therefore, if $AB = DE$ and $BC = EF$ and $m\angle B > m\angle E$, then $AC > DF$. Now, let's adjust $m\angle B > m\angle E$. Would that make $AC > DF$? Yes. See the picture below.

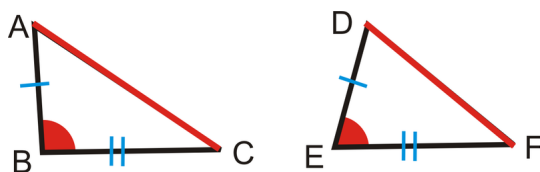

The SAS Inequality Theorem (Hinge Theorem): If two sides of a triangle are congruent to two sides of another triangle, but the included angle of one triangle has greater measure than the included angle of the other triangle, then the third side of the first triangle is longer than the third side of the second triangle.

SSS Inequality Theorem (also called the Converse of the Hinge Theorem): If two sides of a triangle are congruent to two sides of another triangle, but the third side of the first triangle is longer than the third side of the second triangle, then the included angle of the first triangle is greater in measure than the included angle of the second triangle.

Example A

List the sides in order, from shortest to longest.

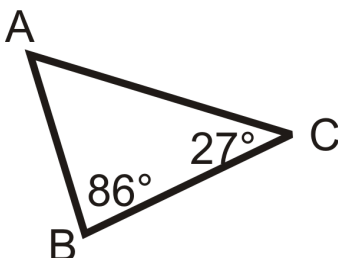

First, we need to find $m\angle A$. From the Triangle Sum Theorem, $m\angle A + 86^\circ + 27^\circ = 180^\circ$. So, $m\angle A = 67^\circ$. Therefore, we can conclude that the longest side is opposite the largest angle. 86° is the largest angle, so AC is the longest side. The next largest angle is 67° , so BC would be the next longest side. 27° is the smallest angle, so AB is the shortest side. In order from shortest to longest, the answer is: AB, BC, AC .

Example B

List the angles in order, from largest to smallest.

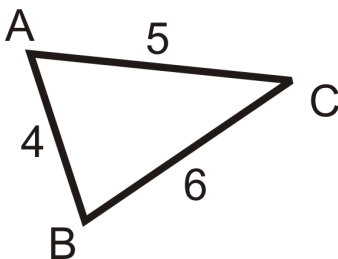

Just like with the sides, the largest angle is opposite the longest side. The longest side is BC , so the largest angle is $\angle A$. Next would be $\angle B$ and finally $\angle C$ is the smallest angle.

Example C

List the sides in order, from least to greatest.

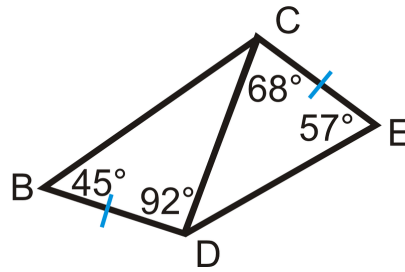

Let's start with $\triangle DCE$. The missing angle is 55° . Therefore the sides, in order are CE, CD , and DE . For $\triangle BCD$, the missing angle is 43° . The order of the sides is BD, CD , and BC . By the SAS Inequality Theorem, we know that $BC > DE$, so the order of all the sides would be: $BD = CE, CD, DE, BC$.

Watch this video for help with the Examples above.

**MEDIA**

Click image to the left for more content.

[CK-12 Foundation: Chapter5ComparingAnglesandSidesB](#)

Concept Problem Revisited

Even though the two sets of lengths are not equal, they both add up to 23. Therefore, the second rider is further away from the parking lot because $110^\circ > 90^\circ$.

Vocabulary

The **Triangle Sum Theorem** states that the three angles in a triangle always add up to 180° . The **median** in a triangle connects the midpoint of one side to the opposite vertex. An **isosceles triangle** is a triangle with at least two congruent sides.

Guided Practice

1. If \overline{XM} is a median of $\triangle XYZ$ and $XY > XZ$, what can we say about $m\angle 1$ and $m\angle 2$?

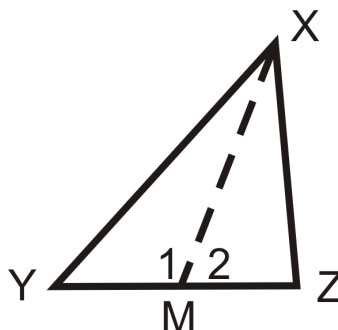

2. List the sides of the two triangles in order, from least to greatest.

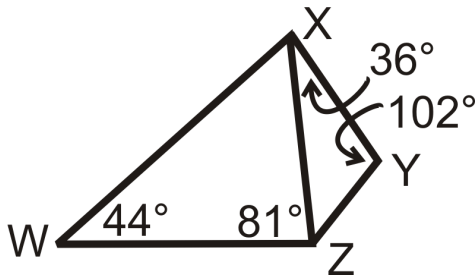

3. Below is isosceles triangle $\triangle ABC$. List everything you can about the triangle and why.

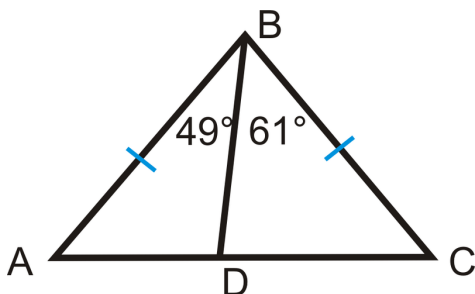

Answers:

1. By the definition of a median, M is the midpoint of \overline{YZ} . This means that $YM = MZ$. $MX = MX$ by the Reflexive Property and we know that $XY > XZ$. Therefore, we can use the SSS Inequality Theorem to conclude that $m\angle 1 > m\angle 2$.

2. Here we have no congruent sides or angles. So, let's look at each triangle separately. Start with $\triangle XYZ$. First the missing angle is 42° . The order of the sides is YZ, XY , and XZ . For $\triangle WXZ$, the missing angle is 55° . The order of these sides is XZ, WZ , and WX . Because the longest side in $\triangle XYZ$ is the shortest side in $\triangle WXZ$, we can put all the sides together in one list: YZ, XY, XZ, WZ, WX .

3. $AB = BC$ because it is given, $m\angle A = m\angle C$ by the Base Angle Theorem, and $AD < DC$ because $m\angle ABD < m\angle CBD$ and the SAS Triangle Inequality Theorem.

Practice

For questions 1-3, list the sides in order from shortest to longest.

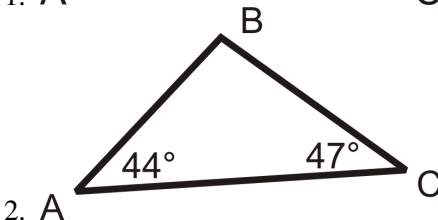
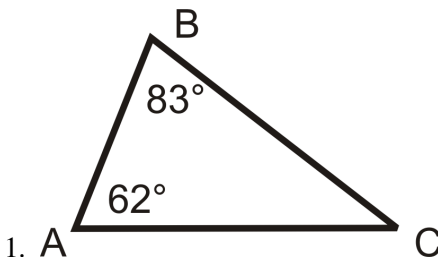

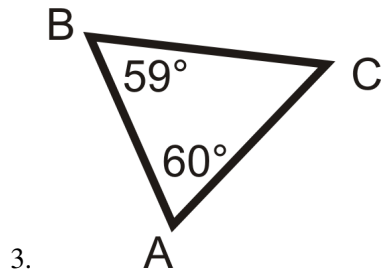

For questions 4-6, list the angles from largest to smallest.

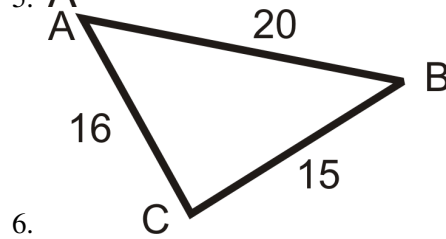
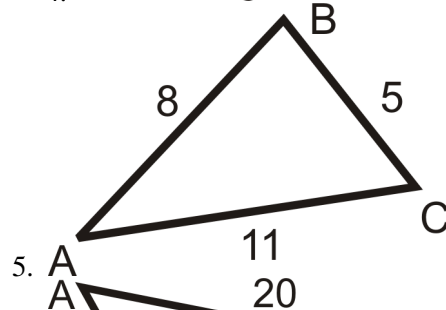
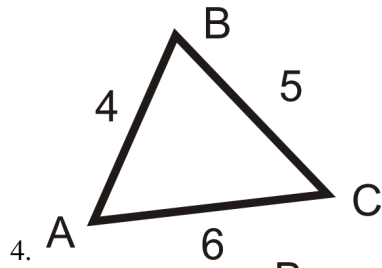

7. Compare $m\angle 1$ and $m\angle 2$.

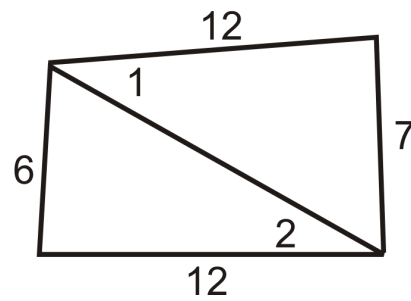

8. List the sides from shortest to longest.

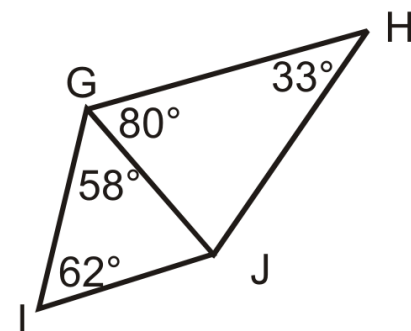

9. Compare $m\angle 1$ and $m\angle 2$. What can you say about $m\angle 3$ and $m\angle 4$?

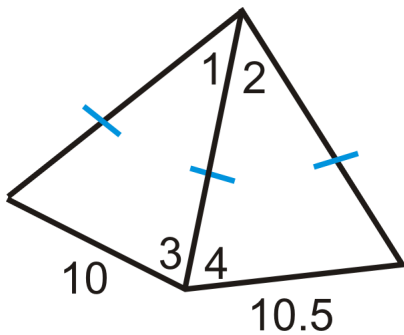

In questions 10-12, compare the measures of a and b .

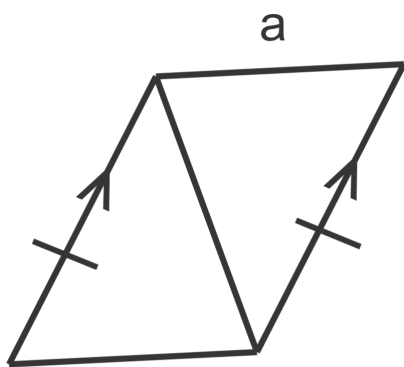

11.

b

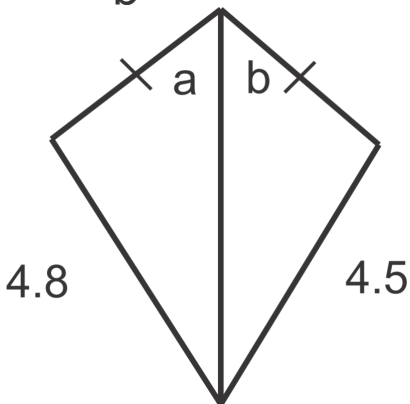

12.

3.2

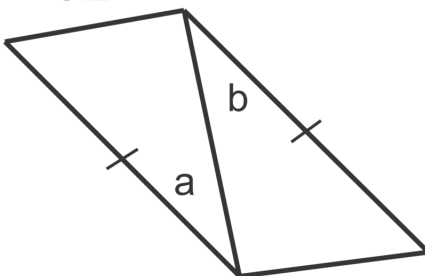

13.

3.3

In questions 13 and 14, list the measures of the sides in order from least to greatest

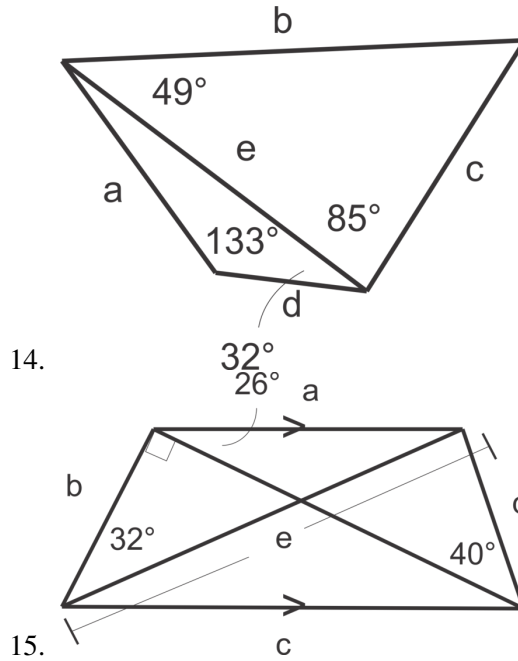

In questions 15 and 16 is the conclusion true or false?

16. Conclusion: $m\angle C < m\angle B < m\angle A$

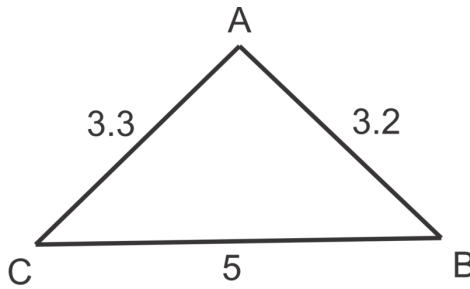

17. Conclusion: $AB < DC$

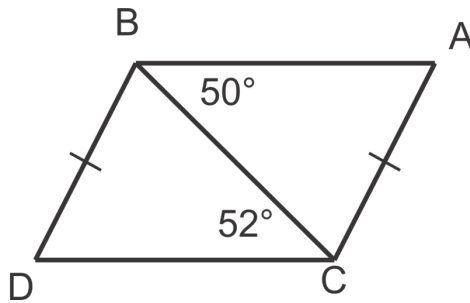

18. If \overline{AB} is a median of $\triangle CAT$ and $CA > AT$, explain why $\angle ABT$ is acute. You may wish to draw a diagram.

5.7 Triangle Inequality Theorem

Here you'll learn the Triangle Inequality Theorem, which will help you to determine whether three side lengths will create a triangle or not.

What if you had to determine whether the three lengths 5, 7 and 10 make a triangle? After completing this Concept, you'll be able to use the Triangle Inequality Theorem to determine if any three side lengths make a triangle.

Watch This



MEDIA

Click image to the left for more content.

[CK-12 Foundation: Chapter5TriangleInequalityTheoremA](#)

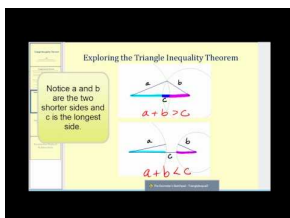

MEDIA

Click image to the left for more content.

[James Sousa:Triangle InequalityTheorem](#)

Guidance

Can any three lengths make a triangle? The answer is no. There are limits on what the lengths can be. For example, the lengths 1, 2, 3 cannot make a triangle because $1 + 2 = 3$, so they would all lie on the same line. The lengths 4, 5, 10 also cannot make a triangle because $4 + 5 = 9$.

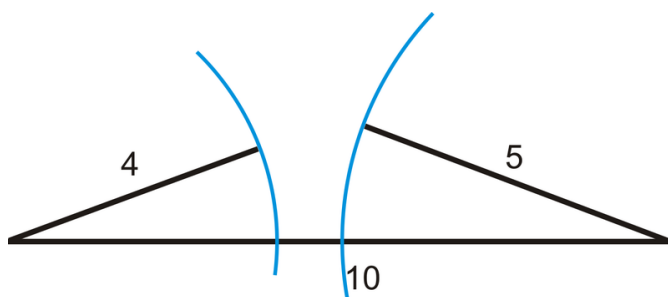

The arc marks show that the two sides would never meet to form a triangle. The **Triangle Inequality Theorem** states that the sum of the lengths of any two sides of a triangle must be greater than the length of the third.

Example A

Do the lengths 4, 11, 8 make a triangle?

To solve this problem, check to make sure that the smaller two numbers add up to be greater than the biggest number. $4 + 8 = 12$ and $12 > 11$ so **yes** these lengths make a triangle.

Example B

Find the length of the third side of a triangle if the other two sides are 10 and 6.

The Triangle Inequality Theorem can also help you find the range of the third side. The two given sides are 6 and 10, so the third side, s , can either be the shortest side or the longest side. For example s could be 5 because $6 + 5 > 10$. It could also be 15 because $6 + 10 > 15$. Therefore, the range of values for s is $4 < s < 16$.



Notice the range is no less than 4, and **not equal** to 4. The third side could be 4.1 because $4.1 + 6 > 10$. For the same reason, s cannot be greater than 16, but it could 15.9, $10 + 6 > 15.9$.

Example C

The base of an isosceles triangle has length 24. What can you say about the length of each leg?

To solve this problem, remember that an isosceles triangle has two congruent sides (the legs). We have to make sure that the sum of the lengths of the legs is greater than 24. In other words, if x is the length of a leg:

$$x + x > 24$$

$$2x > 24$$

$$x > 12$$

Each leg must have a length greater than 12.

Watch this video for help with the Examples above.



MEDIA

Click image to the left for more content.

[CK-12 Foundation: Chapter5TriangleInequalityTheoremB](#)

Concept Problem Revisited

The three lengths 5, 7, and 10 do make a triangle. The sum of the lengths of any two sides is greater than the length of the third.

Vocabulary

An *isosceles triangle* is a triangle with two congruent sides. The congruent sides are called the *legs* and the third side is called the *base*. The *Triangle Inequality Theorem* states that to make a triangle, two sides must add up to be **greater** than the third side.

Guided Practice

Do the lengths below make a triangle?

1. 4.1, 3.5, 7.5
2. 4, 4, 8
3. 6, 7, 8

Answers:

Use the Triangle Inequality Theorem. Test to see if the smaller two numbers add up to be greater than the largest number.

1. $4.1 + 3.5 > 7.5$. Yes this is a triangle because $7.6 > 7.5$.
2. $4 + 4 = 8$. No this is not a triangle because two lengths *cannot equal* the third.
3. $6 + 7 > 8$. Yes this is a triangle because $13 > 8$.

Practice

Determine if the sets of lengths below can make a triangle. If not, state why.

1. 6, 6, 13
2. 1, 2, 3
3. 7, 8, 10
4. 5, 4, 3
5. 23, 56, 85
6. 30, 40, 50
7. 7, 8, 14
8. 7, 8, 15
9. 7, 8, 14.99

If two lengths of the sides of a triangle are given, determine the range of the length of the third side.

10. 8 and 9
11. 4 and 15
12. 20 and 32
13. 2 and 5
14. 10 and 8
15. x and $2x$
16. The legs of an isosceles triangle have a length of 12 each. What can you say about the length of the base?

5.8 Indirect Proof in Algebra and Geometry

Here you'll learn how to write indirect proofs, or proofs by contradiction, by assuming a hypothesis is false.

What if you know something is true but cannot figure out how to prove it directly? After completing this Concept, you'll be able to indirectly prove a statement by way of contradiction.

Watch This



MEDIA

Click image to the left for more content.

[CK-12 Foundation: Chapter5IndirectProofA](#)

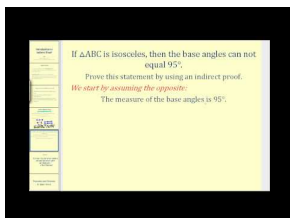

MEDIA

Click image to the left for more content.

[James Sousa:Introduction toIndirect Proof](#)

Guidance

Until now, we have proved theorems true by direct reasoning, where conclusions are drawn from a series of facts and previously proven theorems. However, we cannot always use direct reasoning to prove every theorem.

Indirect Proof or Proof by Contradiction: When the conclusion from a hypothesis is assumed false (or opposite of what it states) and then a contradiction is reached from the given or deduced statements.

In other words, if you are trying to show that something is true, show that if it was not true there would be a contradiction (something else would not make sense).

The steps to follow when proving indirectly are:

- Assume the *opposite* of the conclusion (second half) of the statement.
- Proceed as if this assumption is true to find the *contradiction*.
- Once there is a contradiction, the original statement is true.
- **DO NOT use specific examples.** Use variables so that the contradiction can be generalized.

The easiest way to understand indirect proofs is by example.

Example A (Algebra Example)

If $x = 2$, then $3x - 5 \neq 10$. Prove this statement is true by contradiction.

Remember that in an indirect proof the first thing you do is assume the conclusion of the statement is *false*. In this case, we will assume the *opposite* of "If $x = 2$, then $3x - 5 \neq 10$ ":

If $x = 2$, then $3x - 5 = 10$.

Take this statement as true and solve for x .

$$3x - 5 = 10$$

$$3x = 15$$

$$x = 5$$

But $x = 5$ *contradicts* the given statement that $x = 2$. Hence, our *assumption is incorrect* and $3x - 5 \neq 10$ is *true*.

Example B (Geometry Example)

If $\triangle ABC$ is isosceles, then the measure of the base angles cannot be 92° . Prove this indirectly.

Remember, to start assume the *opposite* of the conclusion.

The measure of the base angles are 92° .

If the base angles are 92° , then they add up to 184° . This *contradicts* the Triangle Sum Theorem that says the three angle measures of all triangles add up to 180° . Therefore, the base angles cannot be 92° .

Example C (Geometry Example)

If $\angle A$ and $\angle B$ are complementary then $\angle A \leq 90^\circ$. Prove this by contradiction.

Assume the *opposite* of the conclusion.

$\angle A > 90^\circ$.

Consider first that the measure of $\angle B$ cannot be negative. So if $\angle A > 90^\circ$ this contradicts the definition of complementary, which says that two angles are complementary if they add up to 90° . Therefore, $\angle A \leq 90^\circ$.

Watch this video for help with the Examples above.



MEDIA

Click image to the left for more content.

[CK-12 Foundation: Chapter5IndirectProofB](#)

Vocabulary

An *Indirect Proof or Proof by Contradiction* is a method of proof where the conclusion from a hypothesis is assumed to be false (or opposite of what it states) and then a contradiction is reached from the given or deduced statements.

Guided Practice

1. If n is an integer and n^2 is odd, then n is odd. Prove this is true indirectly.
2. Prove the SSS Inequality Theorem is true by contradiction. (The SSS Inequality Theorem says: “If two sides of a triangle are congruent to two sides of another triangle, but the third side of the first triangle is longer than the third side of the second triangle, then the included angle of the first triangle’s two congruent sides is greater in measure than the included angle of the second triangle’s two congruent sides.”)
3. If $x = 3$, then $4x + 1 \neq 17$. Prove this statement is true by contradiction.

Answers:

1. First, assume the *opposite* of “ n is odd.”

n is even.

Now, square n and see what happens.

If n is even, then $n = 2a$, where a is any integer.

$$n^2 = (2a)^2 = 4a^2$$

This means that n^2 is a multiple of 4. No odd number can be divided evenly by an even number, so this *contradicts our assumption* that n is even. Therefore, n must be odd if n^2 is odd.

2. First, assume the opposite of the conclusion.

The included angle of the first triangle is less than or equal to the included angle of the second triangle.

If the included angles are equal then the two triangles would be congruent by SAS and the third sides would be congruent by CPCTC. This contradicts the hypothesis of the original statement “the third side of the first triangle is longer than the third side of the second.” Therefore, the included angle of the first triangle must be larger than the included angle of the second.

3. In an indirect proof the first thing you do is assume the conclusion of the statement is *false*. In this case, we will assume the *opposite* of “If $x = 3$, then $4x + 1 \neq 17$ ”:

If $x = 3$, then $4x + 1 = 17$

Take this statement as true and solve for x .

$$4x + 1 = 17$$

$$4x = 16$$

$$x = 4$$

$x = 4$ *contradicts* the given statement that $x = 3$. Hence, our *assumption is incorrect* and $4x + 1 \neq 17$ is *true*.

Practice

Prove the following statements true indirectly.

1. If n is an integer and n^2 is even, then n is even.
2. If $m\angle A \neq m\angle B$ in $\triangle ABC$, then $\triangle ABC$ is not equilateral.
3. If $x > 3$, then $x^2 > 9$.
4. The base angles of an isosceles triangle are congruent.

5. If x is even and y is odd, then $x + y$ is odd.
6. In $\triangle ABE$, if $\angle A$ is a right angle, then $\angle B$ cannot be obtuse.
7. If A , B , and C are collinear, then $AB + BC = AC$ (Segment Addition Postulate).
8. If a collection of nickels and dimes is worth 85 cents, then there must be an odd number of nickels.
9. Hugo is taking a true/false test in his Geometry class. There are five questions on the quiz. The teacher gives her students the following clues: The last answer on the quiz is not the same as the fourth answer. The third answer is true. If the fourth answer is true, then the one before it is false. Use an indirect proof to prove that the last answer on the quiz is true.
10. On a test of 15 questions, Charlie claims that his friend Suzie must have gotten at least 10 questions right. Another friend, Larry, does not agree and suggests that Suzie could not have gotten that many correct. Rebecca claims that Suzie certainly got at least one question correct. If *only one* of these statements is true, how many questions did Suzie get right?
11. If one angle in a triangle is obtuse, then each other angle is acute.
12. If $3x + 7 \geq 13$, then $x \geq 2$.
13. If segment AD is perpendicular to segment BC , then $\angle ABC$ is not a straight angle.
14. If two alternate interior angles are not congruent, then the lines are not parallel.
15. In an isosceles triangle, the median that connects the vertex angle to the midpoint of the base bisects the vertex angle.

Summary

This chapter begins with an introduction to the Midsegment Theorem. The definition of a perpendicular bisector is presented and the Perpendicular Bisector Theorem and its converse are explored. Now that the bisectors of segments have been discussed, the definition of an angle bisector is next and the Angle Bisector Theorem and its converse are presented. The properties of medians and altitudes of triangles are discussed in detail. The entire chapter builds to a discovery of the relationships between the angles and sides in triangles as a foundation for the Triangle Inequality Theorem. The chapter ends with a presentation of indirect proofs.

Chapter Keywords

- Midsegment
- Midsegment Theorem
- Perpendicular Bisector Theorem
- Perpendicular Bisector Theorem Converse
- Point of Concurrency
- Circumcenter
- Concurrency of Perpendicular Bisectors Theorem
- Angle Bisector Theorem
- Angle Bisector Theorem Converse
- Incenter
- Concurrency of Angle Bisectors Theorem
- Median
- Centroid
- Concurrency of Medians Theorem
- Altitude
- Orthocenter
- Triangle Inequality Theorem
- SAS Inequality Theorem
- SSS Inequality Theorem

- Indirect Proof

Chapter Review

If C and E are the midpoints of the sides they lie on, find:

1. The perpendicular bisector of \overline{FD} .
2. The median of \overline{FD} .
3. The angle bisector of $\angle FAD$.
4. A midsegment.
5. An altitude.

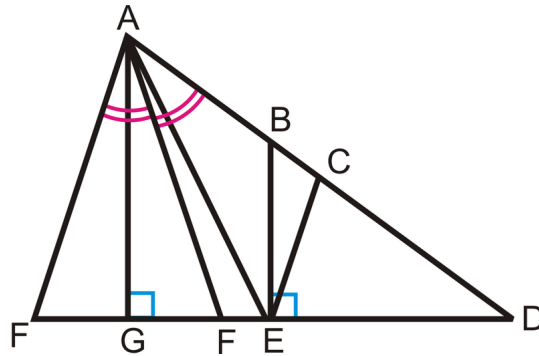

6. Trace $\triangle FAD$ onto a piece of paper with the perpendicular bisector. Construct another perpendicular bisector. What is the point of concurrency called? Use this information to draw the appropriate circle.
7. Trace $\triangle FAD$ onto a piece of paper with the angle bisector. Construct another angle bisector. What is the point of concurrency called? Use this information to draw the appropriate circle.
8. Trace $\triangle FAD$ onto a piece of paper with the median. Construct another median. What is the point of concurrency called? What are its properties?
9. Trace $\triangle FAD$ onto a piece of paper with the altitude. Construct another altitude. What is the point of concurrency called? Which points of concurrency can lie outside a triangle?
10. A triangle has sides with length $x + 6$ and $2x - 1$. Find the range of the third side.

Texas Instruments Resources

In the CK-12 Texas Instruments Geometry FlexBook, there are graphing calculator activities designed to supplement the objectives for some of the lessons in this chapter. See <http://www.ck12.org/flexr/chapter/9690>.

CHAPTER 6

Polygons and Quadrilaterals

Chapter Outline

- 6.1 INTERIOR ANGLES IN CONVEX POLYGONS**
 - 6.2 EXTERIOR ANGLES IN CONVEX POLYGONS**
 - 6.3 PARALLELOGRAMS**
 - 6.4 QUADRILATERALS THAT ARE PARALLELOGRAMS**
 - 6.5 PARALLELOGRAM CLASSIFICATION**
 - 6.6 TRAPEZOIDS**
 - 6.7 KITES**
 - 6.8 QUADRILATERAL CLASSIFICATION**
-

Introduction

This chapter starts with the properties of polygons and narrows to focus on quadrilaterals. We will study several different types of quadrilaterals: parallelograms, rhombi, rectangles, squares, kites and trapezoids. Then, we will prove that different types of quadrilaterals are parallelograms or something more specific.

6.1 Interior Angles in Convex Polygons

Here you'll learn how to find the sum of the interior angles of a polygon and the measure of one interior angle of a regular polygon.

Below is a picture of Devil's Post pile, near Mammoth Lakes, California. These posts are cooled lava (called columnar basalt) and as the lava pools and cools, it ideally would form regular hexagonal columns. However, variations in cooling caused some columns to either not be perfect or pentagonal.

First, define regular in your own words. Then, what is the sum of the angles in a regular hexagon? What would each angle be? After completing this Concept you'll be able to answer questions like these.



Watch This



MEDIA

Click image to the left for more content.

[CK-12 Foundation: Chapter6InteriorAnglesinConvexPolygonsA](#)

Watch the first half of this video.

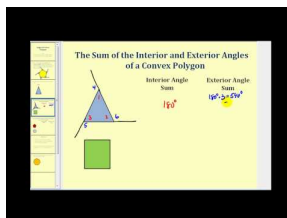

MEDIA

Click image to the left for more content.

[James Sousa:Angles of Convex Polygons](#)

Guidance

Recall that interior angles are the angles inside a closed figure with straight sides. As you can see in the images below, a polygon has the same number of interior angles as it does sides.

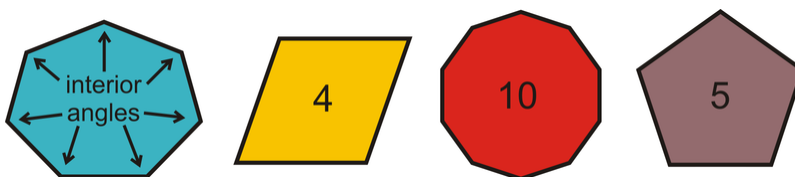

A diagonal connects two non-adjacent vertices of a convex polygon. Also, recall that the sum of the angles in a triangle is 180° . What about other polygons?

Investigation: Polygon Sum Formula

Tools Needed: paper, pencil, ruler, colored pencils (optional)

1. Draw a quadrilateral, pentagon, and hexagon.

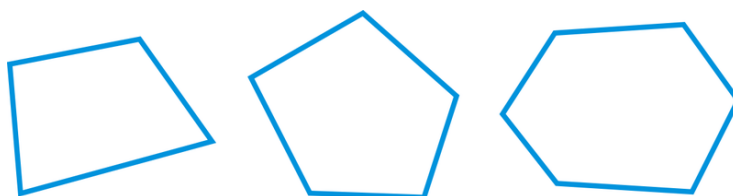

2. Cut each polygon into triangles by drawing all the diagonals from one vertex. Count the number of triangles.

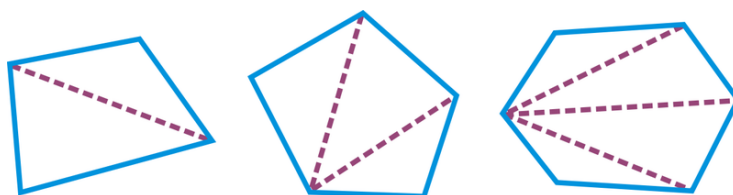

Make sure none of the triangles overlap.

3. Make a table with the information below.

TABLE 6.1:

| <i>Name of Polygon</i> | <i>Number of Sides</i> | <i>Number of \triangles from one vertex</i> | <i>(Column 3) \times ($^\circ$ in a \triangle)</i> | <i>Total Number of Degrees</i> |
|------------------------|------------------------|--|---|--------------------------------|
| Quadrilateral | 4 | 2 | $2 \times 180^\circ$ | 360° |
| Pentagon | 5 | 3 | $3 \times 180^\circ$ | 540° |
| Hexagon | 6 | 4 | $4 \times 180^\circ$ | 720° |

4. Do you see a pattern? Notice that the total number of degrees goes up by 180° . So, if the number sides is n , then the number of triangles from one vertex is $n - 2$. Therefore, the formula would be $(n - 2) \times 180^\circ$.

Polygon Sum Formula: For any n -gon, the sum of the interior angles is $(n - 2) \times 180^\circ$.

A **regular polygon** is a polygon where all sides are congruent and all interior angles are congruent.

Regular Polygon Formula: For any equiangular n -gon, the measure of each angle is $\frac{(n-2) \times 180^\circ}{n}$.

Example A

Find the sum of the interior angles of an octagon.

Use the Polygon Sum Formula and set $n = 8$.

$$(8 - 2) \times 180^\circ = 6 \times 180^\circ = 1080^\circ$$

Example B

The sum of the interior angles of a polygon is 1980° . How many sides does this polygon have?

Use the Polygon Sum Formula and solve for n .

$$\begin{aligned}(n - 2) \times 180^\circ &= 1980^\circ \\ 180^\circ n - 360^\circ &= 1980^\circ \\ 180^\circ n &= 2340^\circ \\ n &= 13 \quad \text{The polygon has 13 sides.}\end{aligned}$$

Example C

How many degrees does each angle in an equiangular nonagon have?

First we need to find the sum of the interior angles in a nonagon, set $n = 9$.

$$(9 - 2) \times 180^\circ = 7 \times 180^\circ = 1260^\circ$$

Second, because the nonagon is equiangular, every angle is equal. Dividing 1260° by 9 we get each angle is 140° .

Watch this video for help with the Examples above.



MEDIA

Click image to the left for more content.

[CK-12 Foundation: Chapter6InteriorAnglesinConvexPolygonsB](#)

Concept Problem Revisited

A regular polygon has congruent sides and angles. A regular hexagon has $(6 - 2)180^\circ = 4 \cdot 180^\circ = 720^\circ$ total degrees. Each angle would be 720° divided by 6 or 120° .

Vocabulary

The *interior angle* of a polygon is one of the angles on the inside. A *regular polygon* is a polygon that is *equilateral* (has all congruent sides) and *equiangular* (has all congruent angles).

Guided Practice

- Find the measure of x .

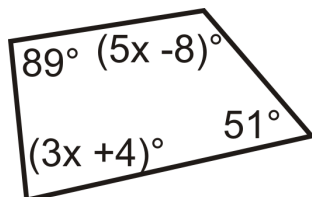

- The interior angles of a pentagon are $x^\circ, x^\circ, 2x^\circ, 2x^\circ$, and $2x^\circ$. What is x ?
- What is the sum of the interior angles in a 100-gon?

Answers:

- From the Polygon Sum Formula we know that a quadrilateral has interior angles that sum to $(4 - 2) \times 180^\circ = 360^\circ$. Write an equation and solve for x .

$$\begin{aligned} 89^\circ + (5x - 8)^\circ + (3x + 4)^\circ + 51^\circ &= 360^\circ \\ 8x &= 224 \\ x &= 28 \end{aligned}$$

- From the Polygon Sum Formula we know that a pentagon has interior angles that sum to $(5 - 2) \times 180^\circ = 540^\circ$. Write an equation and solve for x .

$$\begin{aligned} x^\circ + x^\circ + 2x^\circ + 2x^\circ + 2x^\circ &= 540^\circ \\ 8x &= 540 \\ x &= 67.5 \end{aligned}$$

- Use the Polygon Sum Formula. $(100 - 2) \times 180^\circ = 17,640^\circ$.

Practice

- Fill in the table.

TABLE 6.2:

| # of sides | Sum of the Interior Angles | Measure of Each Interior Angle in a Regular n -gon |
|------------|----------------------------|--|
| 3 | | 60° |

TABLE 6.2: (continued)

| # of sides | Sum of the Interior Angles | Measure of Each Interior Angle in a Regular n -gon |
|------------|----------------------------|--|
| 4 | 360° | |
| 5 | 540° | 108° |
| 6 | | 120° |
| 7 | | |
| 8 | | |
| 9 | | |
| 10 | | |
| 11 | | |
| 12 | | |

- What is the sum of the angles in a 15-gon?
- What is the sum of the angles in a 23-gon?
- The sum of the interior angles of a polygon is 4320° . How many sides does the polygon have?
- The sum of the interior angles of a polygon is 3240° . How many sides does the polygon have?
- What is the measure of each angle in a regular 16-gon?
- What is the measure of each angle in an equiangular 24-gon?
- Each interior angle in a regular polygon is 156° . How many sides does it have?
- Each interior angle in an equiangular polygon is 90° . How many sides does it have?

For questions 10-18, find the value of the missing variable(s).

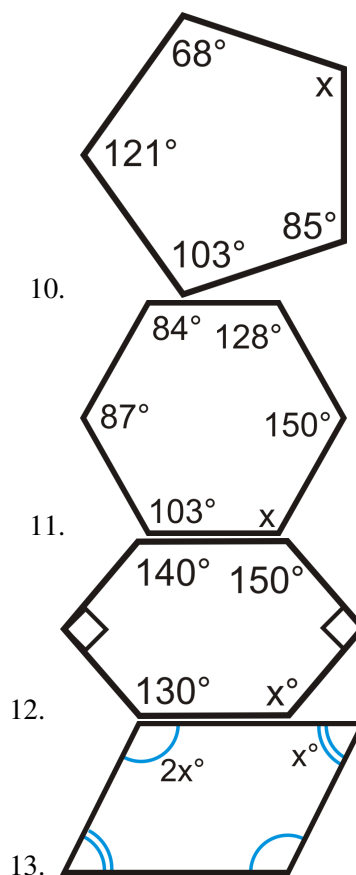

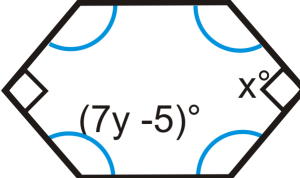
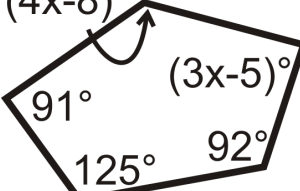
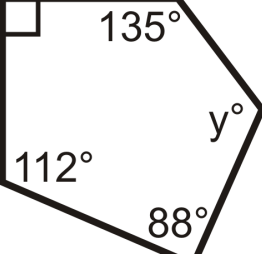
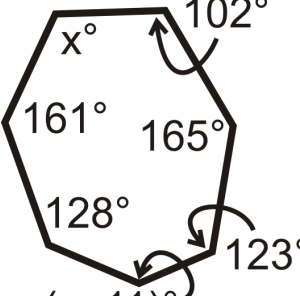
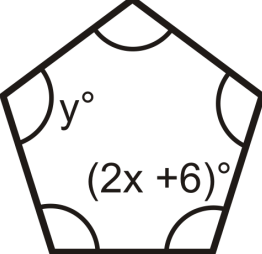
14. 
15. 
16. 
17. 
18. 

19. The interior angles of a hexagon are x° , $(x + 1)^\circ$, $(x + 2)^\circ$, $(x + 3)^\circ$, $(x + 4)^\circ$, and $(x + 5)^\circ$. What is x ?

6.2 Exterior Angles in Convex Polygons

Here you'll learn the Exterior Angle Sum Theorem that states that the exterior angles of a polygon always add up to 360° .

What if you were given a twelve-sided regular polygon? How could you determine the measure of each of its exterior angles? After completing this Concept, you'll be able to use the Exterior Angle Sum Theorem to solve problems like this one.

Watch This



MEDIA

Click image to the left for more content.

[CK-12 Foundation: Chapter6ExteriorAnglesinConvexPolygonsA](#)

Watch the second half of this video.

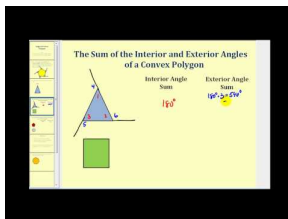

MEDIA

Click image to the left for more content.

[James Sousa:Angles of Convex Polygons](#)

Guidance

Recall that an **exterior angle** is an angle on the outside of a polygon and is formed by extending a side of the polygon.

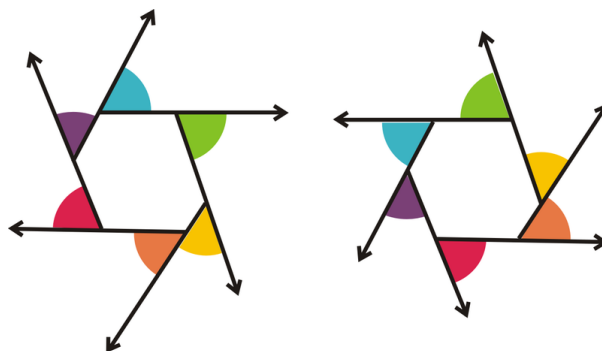

As you can see, there are two sets of exterior angles for any vertex on a polygon. It does not matter which set you use because one set is just the vertical angles of the other, making the measurement equal. In the picture above, the color-matched angles are vertical angles and congruent. The **Exterior Angle Sum Theorem** stated that the exterior angles of a triangle add up to 360° . Let's extend this theorem to all polygons.

Investigation: Exterior Angle Tear-Up

Tools Needed: pencil, paper, colored pencils, scissors

1. Draw a hexagon like the hexagons above. Color in the exterior angles as well.
2. Cut out each exterior angle and label them 1-6.



3. Fit the six angles together by putting their vertices together. What happens?



The angles all fit around a point, meaning that the exterior angles of a hexagon add up to 360° , just like a triangle. We can say this is true for all polygons.

Exterior Angle Sum Theorem: The sum of the exterior angles of any polygon is 360° .

Proof of the Exterior Angle Sum Theorem:

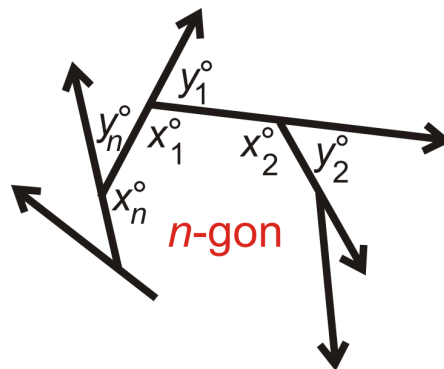

Given: Any n -gon with n sides, n interior angles and n exterior angles.

Prove: n exterior angles add up to 360°

NOTE: The interior angles are x_1, x_2, \dots, x_n .

The exterior angles are y_1, y_2, \dots, y_n .

TABLE 6.3:

| Statement | Reason |
|--|--------|
| 1. Any n -gon with n sides, n interior angles and n exterior angles. | Given |

TABLE 6.3: (continued)

| <i>Statement</i> | <i>Reason</i> |
|--|--|
| 2. x_n° and y_n° are a linear pair | Definition of a linear pair |
| 3. x_n° and y_n° are supplementary | Linear Pair Postulate |
| 4. $x_n^\circ + y_n^\circ = 180^\circ$ | Definition of supplementary angles |
| 5. $(x_1^\circ + x_2^\circ + \dots + x_n^\circ) + (y_1^\circ + y_2^\circ + \dots + y_n^\circ) = 180^\circ n$ | Sum of all interior and exterior angles in an n -gon |
| 6. $(n - 2)180^\circ = (x_1^\circ + x_2^\circ + \dots + x_n^\circ)$ | Polygon Sum Formula |
| 7. $180^\circ n = (n - 2)180^\circ + (y_1^\circ + y_2^\circ + \dots + y_n^\circ)$ | Substitution PoE |
| 8. $180^\circ n = 180^\circ n - 360^\circ + (y_1^\circ + y_2^\circ + \dots + y_n^\circ)$ | Distributive PoE |
| 9. $360^\circ = (y_1^\circ + y_2^\circ + \dots + y_n^\circ)$ | Subtraction PoE |

Example A

What is y ?

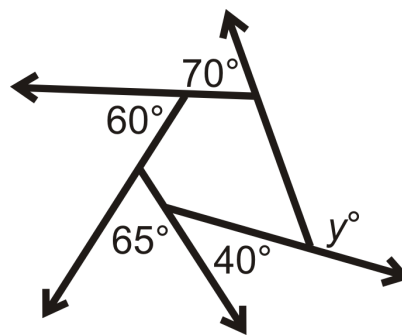

y is an exterior angle, as well as all the other given angle measures. Exterior angles add up to 360° , so set up an equation.

$$70^\circ + 60^\circ + 65^\circ + 40^\circ + y = 360^\circ$$

$$y = 125^\circ$$

Example B

What is the measure of each exterior angle of a regular heptagon?

Because the polygon is regular, each interior angle is equal. This also means that all the exterior angles are equal. The exterior angles add up to 360° , so each angle is $\frac{360^\circ}{7} \approx 51.43^\circ$.

Example C

What is the sum of the exterior angles in a regular 15-gon?

The sum of the exterior angles in any convex polygon, including a regular 15-gon, is 360° .

Watch this video for help with the Examples above.



MEDIA

 Click image to the left for more content.

CK-12 Foundation: Chapter6ExteriorAnglesinConvexPolygonsB

Concept Problem Revisited

The exterior angles of a regular polygon sum to 360° . The measure of each exterior angle in a dodecagon (twelve-sided regular polygon) is $\frac{360^\circ}{12} = 30^\circ$.

Vocabulary

An **exterior angle** is an angle that is formed by extending a side of the polygon. A **regular** polygon is a polygon in which all of its sides and all of its angles are congruent.

Guided Practice

Find the measure of each exterior angle for each regular polygon below:

- 12-gon
- 100-gon
- 36-gon

Answers:

For each, divide 360° by the given number of sides.

- 30°
- 3.6°
- 10°

Practice

- What is the measure of each exterior angle of a regular decagon?
- What is the measure of each exterior angle of a regular 30-gon?
- What is the sum of the exterior angles of a regular 27-gon?

Find the measure of the missing variables:

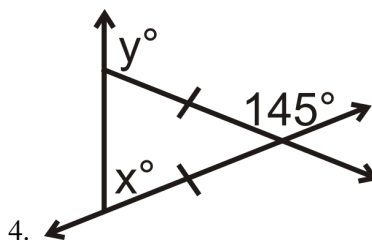

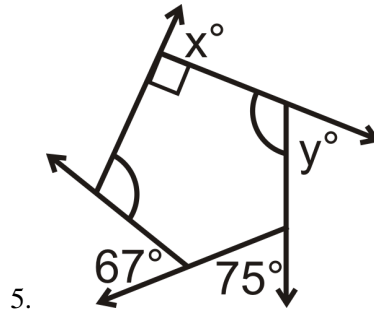

6. The exterior angles of a quadrilateral are x° , $2x^\circ$, $3x^\circ$, and $4x^\circ$. What is x ?

Find the measure of each exterior angle for each regular polygon below:

7. octagon
8. nonagon
9. triangle
10. pentagon
11. 50-gon
12. heptagon
13. 34-gon
14. **Challenge** Each interior angle forms a linear pair with an exterior angle. In a regular polygon you can use two different formulas to find the measure of each exterior angle. One way is $\frac{360^\circ}{n}$ and the other is $180^\circ - \frac{(n-2)180^\circ}{n}$ (180° minus Equiangular Polygon Formula). Use algebra to show these two expressions are equivalent.
15. **Angle Puzzle** Find the measures of the lettered angles below given that $m \parallel n$.

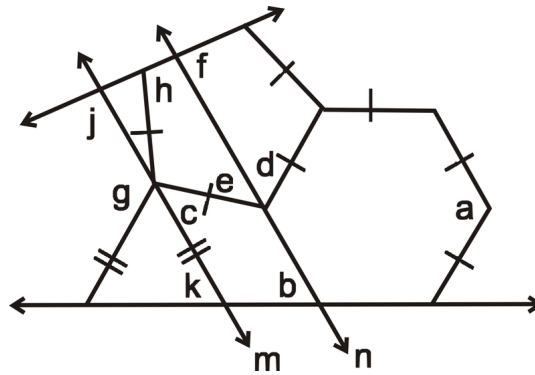

6.3 Parallelograms

Here you'll learn what a parallelogram is and how to apply theorems about its sides, angles, and diagonals.

What if a college wanted to build two walkways through a parallelogram-shaped courtyard between two buildings? The walkways would be 50 feet and 68 feet long and would be built on the diagonals of the parallelogram with a fountain where they intersect. Where would the fountain be? After completing this Concept, you'll be able to answer questions like this by applying your knowledge of parallelograms.

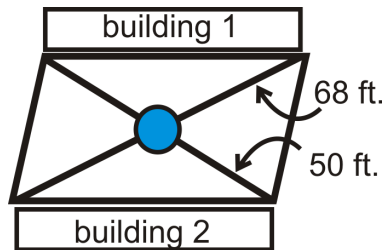

Watch This



MEDIA

Click image to the left for more content.

[CK-12 Foundation: Chapter6ParallelogramsA](#)

Learn more about parallelogram properties by watching the video at this link.

Guidance

A **parallelogram** is a quadrilateral with two pairs of parallel sides. Here are some examples:

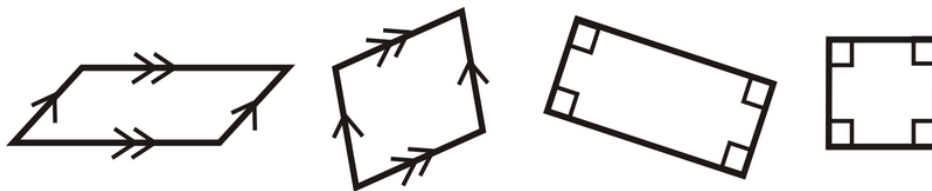

Notice that each pair of sides is marked parallel. As is the case with the rectangle and square, recall that two lines are parallel when they are perpendicular to the same line. Once we know that a quadrilateral is a parallelogram, we can discover some additional properties.

Investigation: Properties of Parallelograms

Tools Needed: Paper, pencil, ruler, protractor

1. Draw a set of parallel lines by placing your ruler on the paper and drawing a line on either side of it. Make your lines 3 inches long.

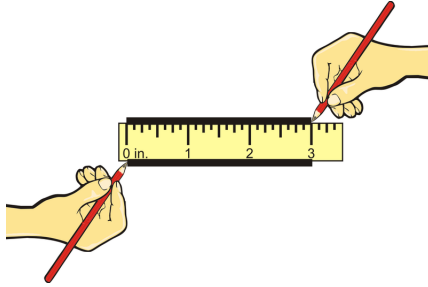

2. Rotate the ruler and repeat this so that you have a parallelogram. Your second set of parallel lines can be any length. If you have colored pencils, outline the parallelogram in another color.

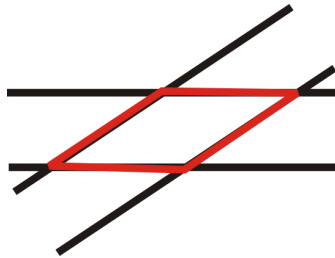

3. Measure the four interior angles of the parallelogram as well as the length of each side. Can you conclude anything about parallelograms, other than opposite sides are parallel?
4. Draw the diagonals. Measure each and then measure the lengths from the point of intersection to each vertex.

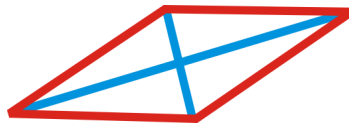

To continue to explore the properties of a parallelogram, see the website:

<http://www.mathwarehouse.com/geometry/quadrilaterals/parallelograms/interactive-parallelgram.php>

In the above investigation, we drew a parallelogram. From this investigation we can conclude:

Opposite Sides Theorem: If a quadrilateral is a parallelogram, then the opposite sides are congruent.

Opposite Angles Theorem: If a quadrilateral is a parallelogram, then the opposite angles are congruent.

Consecutive Angles Theorem: If a quadrilateral is a parallelogram, then the consecutive angles are supplementary.

Parallelogram Diagonals Theorem: If a quadrilateral is a parallelogram, then the diagonals bisect each other.

To prove the first three theorems, one of the diagonals must be added to the figure and then the two triangles can be proved congruent.

Proof of Opposite Sides Theorem:

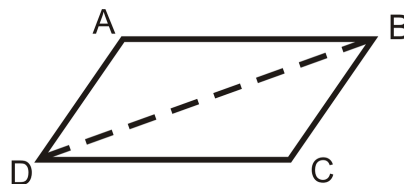

Given: $ABCD$ is a parallelogram with diagonal \overline{BD}

Prove: $\overline{AB} \cong \overline{DC}$, $\overline{AD} \cong \overline{BC}$

TABLE 6.4:

| <i>Statement</i> | <i>Reason</i> |
|--|-----------------------------------|
| 1. $ABCD$ is a parallelogram with diagonal \overline{BD} | Given |
| 2. $\overline{AB} \parallel \overline{DC}$, $\overline{AD} \parallel \overline{BC}$ | Definition of a parallelogram |
| 3. $\angle ABD \cong \angle BDC$, $\angle ADB \cong \angle DBC$ | Alternate Interior Angles Theorem |
| 4. $\overline{DB} \cong \overline{DB}$ | Reflexive PoC |
| 5. $\triangle ABD \cong \triangle CDB$ | ASA |
| 6. $\overline{AB} \cong \overline{DC}$, $\overline{AD} \cong \overline{BC}$ | CPCTC |

Example A

$ABCD$ is a parallelogram. If $m\angle A = 56^\circ$, find the measure of the other three angles.

Draw a picture. When labeling the vertices, the letters are listed, in order, clockwise.

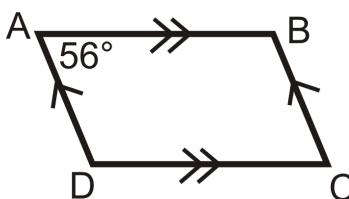

If $m\angle A = 56^\circ$, then $m\angle C = 56^\circ$ because they are opposite angles. $\angle B$ and $\angle D$ are consecutive angles with $\angle A$, so they are both supplementary to $\angle A$. $m\angle A + m\angle B = 180^\circ$, $56^\circ + m\angle B = 180^\circ$, $m\angle B = 124^\circ$. $m\angle D = 124^\circ$.

Example B

Find the values of x and y .

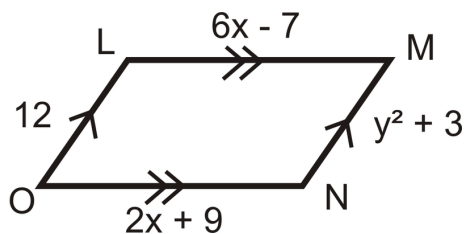

Opposite sides are congruent, so we can set each pair equal to each other and solve both equations.

$$\begin{aligned}
 6x - 7 &= 2x + 9 \\
 4x &= 16 \\
 x &= 4
 \end{aligned}$$

$$\begin{aligned}
 y^2 + 3 &= 12 \\
 y^2 &= 9 \\
 y &= 3 \text{ or } -3
 \end{aligned}$$

Even though $y = 3$ or -3 , lengths cannot be negative, so $y = 3$.

Example C

Show that the diagonals of $FGHJ$ bisect each other.

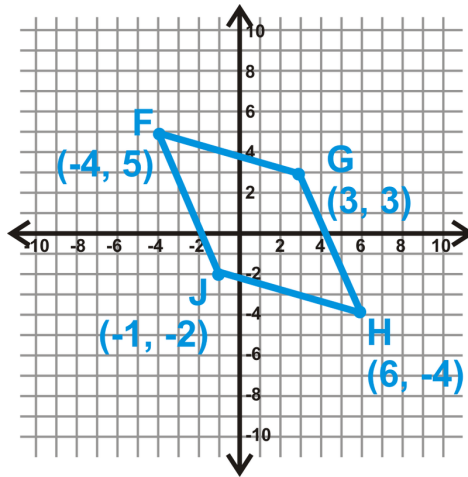

The easiest way to show this is to find the midpoint of each diagonal. If it is the same point, you know they intersect at each other's midpoint and, by definition, cuts a line in half.

$$\text{Midpoint of } \overline{FH} : \left(\frac{-4+6}{2}, \frac{5-4}{2} \right) = (1, 0.5)$$

$$\text{Midpoint of } \overline{GJ} : \left(\frac{3-1}{2}, \frac{3-2}{2} \right) = (1, 0.5)$$

Watch this video for help with the Examples above.



MEDIA

Click image to the left for more content.

[CK-12 Foundation: Chapter6ParallelogramsB](#)

Concept Problem Revisited

By the Parallelogram Diagonals Theorem, the fountain is going to be 34 feet from either endpoint on the 68 foot diagonal and 25 feet from either endpoint on the 50 foot diagonal.

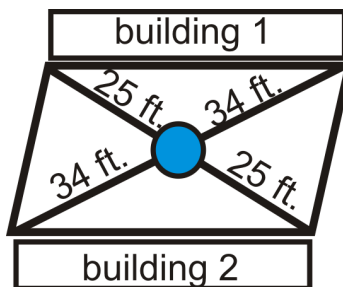

Vocabulary

A *parallelogram* is a quadrilateral with two pairs of parallel sides.

Guided Practice

1. $SAND$ is a parallelogram, $SY = 4x - 11$ and $YN = x + 10$. Solve for x .

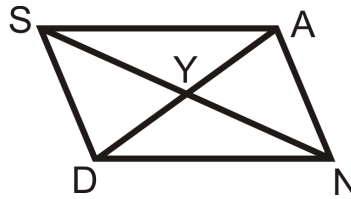

2. Find the measures of a and b in the parallelogram below:

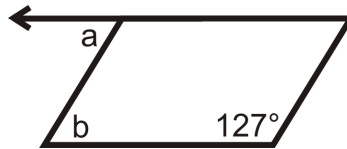

3. If $m\angle B = 72^\circ$ in parallelogram $ABCD$, find the other three angles.

Answers:

1. Because this is a parallelogram, the diagonals bisect each other and $SY \cong YN$.

$$\begin{aligned} SY &= YN \\ 4x - 11 &= x + 10 \\ 3x &= 21 \\ x &= 7 \end{aligned}$$

2. Consecutive angles are supplementary so $127^\circ + m\angle b = 180^\circ$ which means that $m\angle b = 53^\circ$. a and b are alternate interior angles and since the lines are parallel (since its a parallelogram), that means that $m\angle a = m\angle b = 53^\circ$.
3. $m\angle D = 72^\circ$ as well, because opposite angles are congruent. $\angle A$ and $\angle C$ are supplementary with $\angle D$, so $m\angle A = m\angle C = 108^\circ$.

Practice

- If $m\angle S = 143^\circ$ in parallelogram $PQRS$, find the other three angles.
- If $\overline{AB} \perp \overline{BC}$ in parallelogram $ABCD$, find the measure of all four angles.
- If $m\angle F = x^\circ$ in parallelogram $EFGH$, find expressions for the other three angles in terms of x .

For questions 4-11, find the measures of the variable(s). All the figures below are parallelograms.

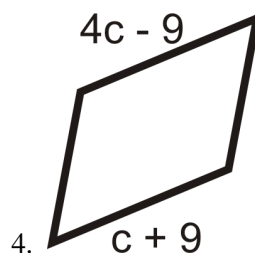

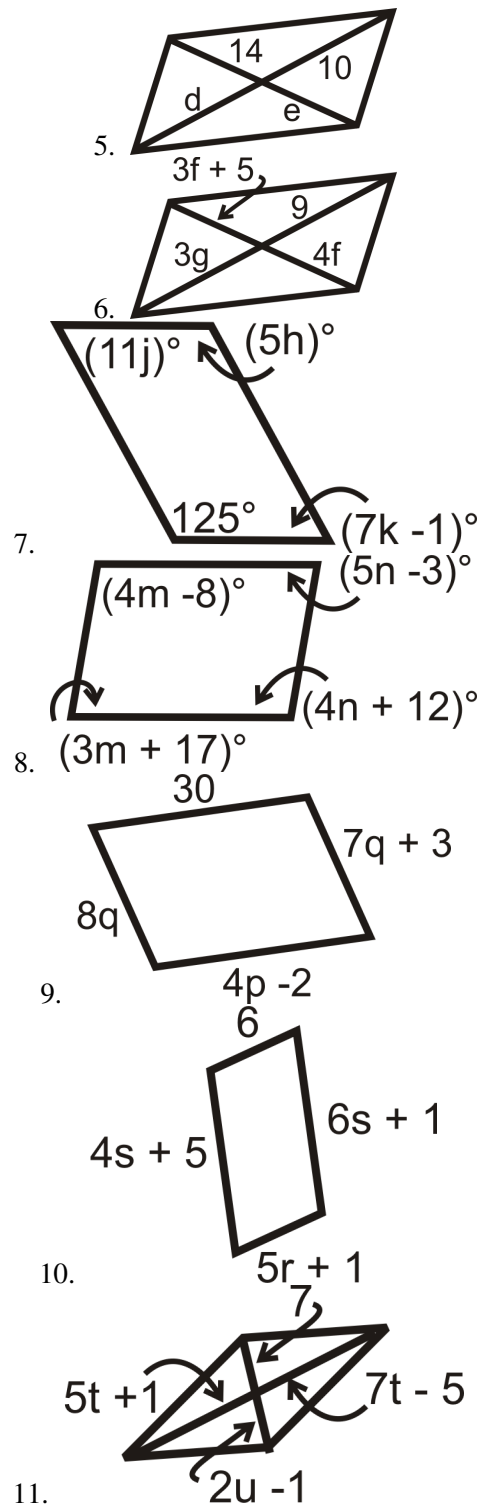

Use the parallelogram *WAVE* to find:

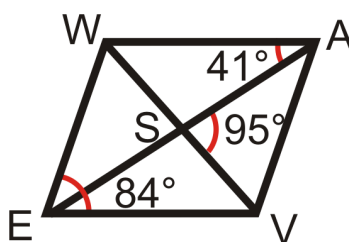

12. $m\angle AWE$
13. $m\angle ESV$
14. $m\angle WEA$
15. $m\angle AVW$

In the parallelogram $SNOW$, $ST = 6$, $NW = 4$, $m\angle OSW = 36^\circ$, $m\angle SNW = 58^\circ$ and $m\angle NTS = 80^\circ$. (*diagram is not drawn to scale*)

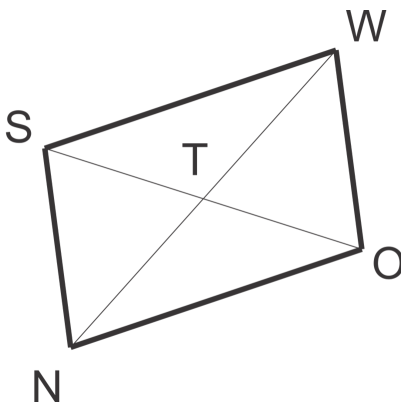

16. SO
17. NT
18. $m\angle NWS$
19. $m\angle SOW$

Plot the points $E(-1, 3)$, $F(3, 4)$, $G(5, -1)$, $H(1, -2)$ and use parallelogram $EFGH$ for problems 20-23.

20. Find the coordinates of the point at which the diagonals intersect. How did you do this?
21. Find the slopes of all four sides. What do you notice?
22. Use the distance formula to find the lengths of all four sides. What do you notice?
23. Make a conjecture about how you might determine whether a quadrilateral in the coordinate is a parallelogram.

Write a two-column proof.

24. ***Opposite Angles Theorem***

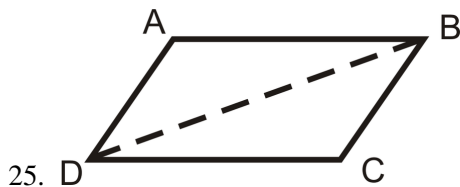

25. D
26. Given
27. :
28. $ABCD$
29. is a parallelogram with diagonal
30. \overline{BD}
31. Prove
32. :
33. $\angle A \cong \angle C$
34. ***Parallelogram Diagonals Theorem***

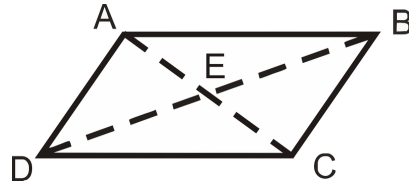

Given: $ABCD$ is a parallelogram with diagonals \overline{BD} and \overline{AC}

Prove: $\overline{AE} \cong \overline{EC}$, $\overline{DE} \cong \overline{EB}$

Use the diagram below to find the indicated lengths or angle measures for problems 26-29. The two quadrilaterals that share a side are parallelograms.

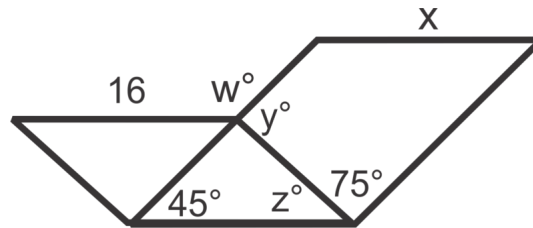

26. w
27. x
28. y
29. z

6.4 Quadrilaterals that are Parallelograms

Here you'll learn how to prove that a quadrilateral is a parallelogram.

What if four friends, Geo, Trig, Algie, and Calc were marking out a baseball diamond? Geo is standing at home plate. Trig is 90 feet away at 3rd base, Algie is 127.3 feet away at 2nd base, and Calc is 90 feet away at 1st base. The angle at home plate is 90°, from 1st to 3rd is 90°. Find the length of the other diagonal and determine if the baseball diamond is a parallelogram. After completing this Concept, you'll be able to answer questions like this based on your knowledge of parallelograms.

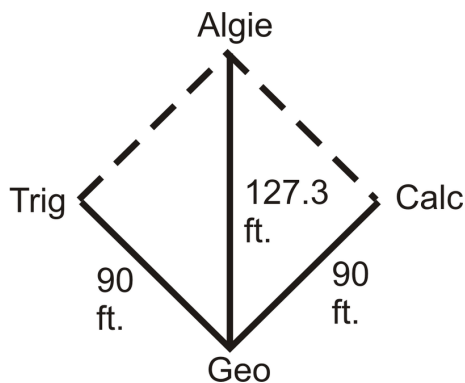

Watch This



MEDIA

Click image to the left for more content.

CK-12 Foundation: Chapter6QuadrilateralsthatareParallelogramsA

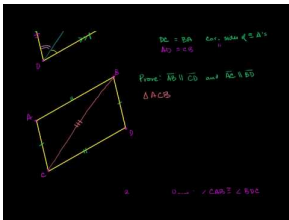

MEDIA

Click image to the left for more content.

KhanAcademy: Opposite Sides of a Parallelogram Congruent

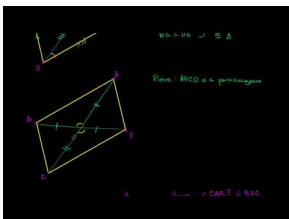

MEDIA

Click image to the left for more content.

[KhanAcademy: Diagonals of aParallelogram Bisect Each Other](#)

Guidance

Recall that a parallelogram is a quadrilateral with two pairs of parallel sides. Even if a quadrilateral is not marked with having two pairs of sides, it still might be a parallelogram. The following is a list of theorems that will help you decide if a quadrilateral is a parallelogram or not.

Opposite Sides Theorem Converse: If the opposite sides of a quadrilateral are congruent, then the figure is a parallelogram.

Opposite Angles Theorem Converse: If the opposite angles of a quadrilateral are congruent, then the figure is a parallelogram.

Parallelogram Diagonals Theorem Converse: If the diagonals of a quadrilateral bisect each other, then the figure is a parallelogram.

Theorem: If a quadrilateral has one set of parallel lines that are also congruent, then it is a parallelogram.

Each of these theorems can be a way to show that a quadrilateral is a parallelogram.

Proof of the Opposite Sides Theorem Converse:

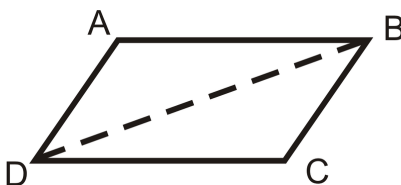

Given: $\overline{AB} \cong \overline{DC}$, $\overline{AD} \cong \overline{BC}$

Prove: $ABCD$ is a parallelogram

TABLE 6.5:

| <i>Statement</i> | <i>Reason</i> |
|--|------------------------------------|
| 1. $\overline{AB} \cong \overline{DC}$, $\overline{AD} \cong \overline{BC}$ | Given |
| 2. $\overline{DB} \cong \overline{DB}$ | Reflexive PoC |
| 3. $\triangle ABD \cong \triangle CDB$ | SSS |
| 4. $\angle ABD \cong \angle BDC$, $\angle ADB \cong \angle DBC$ | CPCTC |
| 5. $\overline{AB} \parallel \overline{DC}$, $\overline{AD} \parallel \overline{BC}$ | Alternate Interior Angles Converse |
| 6. $ABCD$ is a parallelogram | Definition of a parallelogram |

To show that a quadrilateral is a parallelogram in the $x - y$ plane, you will need to use a combination of the slope formulas, the distance formula and the midpoint formula. For example, to use the Definition of a Parallelogram, you would need to *find the slope of all four sides* to see if the opposite sides are parallel. To use the Opposite Sides Converse, you would have to find the length (*using the distance formula*) of each side to see if the opposite sides

are congruent. To use the Parallelogram Diagonals Converse, you would need to use the *midpoint formula* for each diagonal to see if the midpoint is the same for both. Finally, you can use the last Theorem in this Concept (that if one pair of opposite sides is both congruent and parallel then the quadrilateral is a parallelogram) in the coordinate plane. To use this theorem, you would need to show that one pair of opposite sides has the same slope (*slope formula*) and the same length (*distance formula*).

Example A

Write a two-column proof.

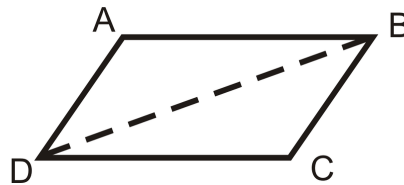

Given: $\overline{AB} \parallel \overline{DC}$ and $\overline{AB} \cong \overline{DC}$

Prove: $ABCD$ is a parallelogram

TABLE 6.6:

| <i>Statement</i> | <i>Reason</i> |
|--|---------------------------|
| 1. $\overline{AB} \parallel \overline{DC}$ and $\overline{AB} \cong \overline{DC}$ | Given |
| 2. $\angle ABD \cong \angle BDC$ | Alternate Interior Angles |
| 3. $\overline{DB} \cong \overline{DB}$ | Reflexive PoC |
| 4. $\triangle ABD \cong \triangle CDB$ | SAS |
| 5. $\overline{AD} \cong \overline{BC}$ | CPCTC |
| 6. $ABCD$ is a parallelogram | Opposite Sides Converse |

Example B

Is quadrilateral $EFGH$ a parallelogram? How do you know?

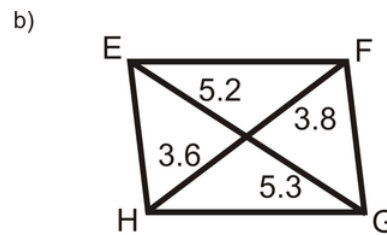
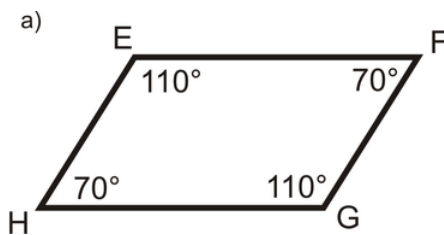

For part a, the opposite angles are equal, so by the Opposite Angles Theorem Converse, $EFGH$ is a parallelogram. In part b, the diagonals do not bisect each other, so $EFGH$ is not a parallelogram.

Example C

Is the quadrilateral $ABCD$ a parallelogram?

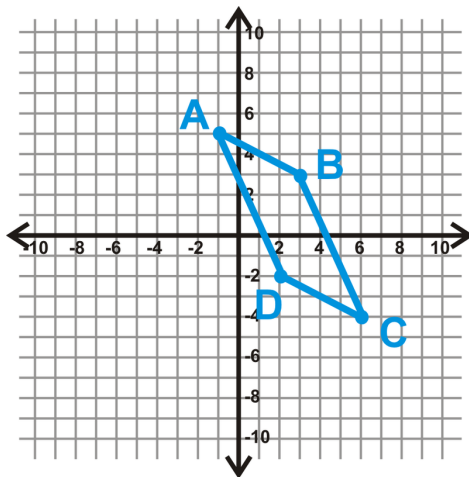

First, find the length of AB and CD .

$$\begin{aligned} AB &= \sqrt{(-1-3)^2 + (5-3)^2} \\ &= \sqrt{(-4)^2 + 2^2} \\ &= \sqrt{16+4} \\ &= \sqrt{20} \end{aligned}$$

$$\begin{aligned} CD &= \sqrt{(2-6)^2 + (-2+4)^2} \\ &= \sqrt{(-4)^2 + 2^2} \\ &= \sqrt{16+4} \\ &= \sqrt{20} \end{aligned}$$

$AB = CD$, so if the two lines have the same slope, $ABCD$ is a parallelogram.

$$\text{Slope } AB = \frac{5-3}{-1-3} = \frac{2}{-4} = -\frac{1}{2} \quad \text{Slope } CD = \frac{-2+4}{2-6} = \frac{2}{-4} = -\frac{1}{2}$$

Therefore, $ABCD$ is a parallelogram.

Watch this video for help with the Examples above.



MEDIA

Click image to the left for more content.

[CK-12 Foundation: Chapter6QuadrilateralsthatareParallelogramsB](#)

Concept Problem Revisited

First, we can use the Pythagorean Theorem to find the length of the second diagonal.

$$\begin{aligned} 90^2 + 90^2 &= d^2 \\ 8100 + 8100 &= d^2 \\ 16200 &= d^2 \\ d &= 127.3 \end{aligned}$$

This means that the diagonals are equal. If the diagonals are equal, the other two sides of the diamond are also 90 feet. Therefore, the baseball diamond is a parallelogram.

Vocabulary

A **parallelogram** is a quadrilateral with two pairs of parallel sides.

Guided Practice

1. What value of x would make $ABCD$ a parallelogram?

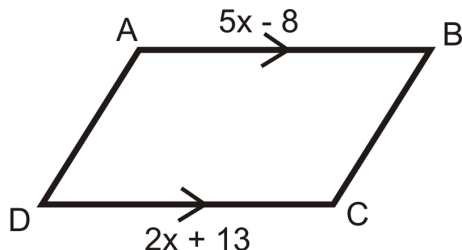

2. Is the quadrilateral $RSTU$ a parallelogram?

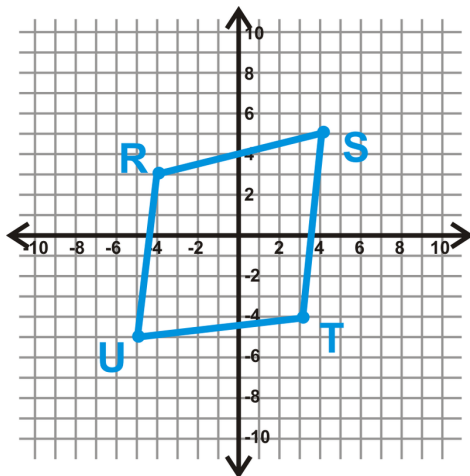

3. If a quadrilateral has one pair of parallel sides is it a parallelogram?

Answers:

1. $\overline{AB} \parallel \overline{DC}$ from the markings. Therefore, $ABCD$ would be a parallelogram if $AB = DC$ as well.

$$5x - 8 = 2x + 13$$

$$3x = 21$$

$$x = 7$$

In order for $ABCD$ to be a parallelogram, x must equal 7.

2. Let's use the Parallelogram Diagonals Converse to determine if $RSTU$ is a parallelogram. Find the midpoint of each diagonal.

$$\text{Midpoint of } RT = \left(\frac{-4+3}{2}, \frac{3-4}{2} \right) = (-0.5, -0.5)$$



$$\text{Midpoint of } SU = \left(\frac{4-5}{2}, \frac{5-5}{2} \right) = (-0.5, 0)$$

Because the midpoint is not the same, $RSTU$ is not a parallelogram.

3. Although it has one pair of parallel sides, this quadrilateral is not a parallelogram because its opposite sides are not necessarily congruent.

Practice

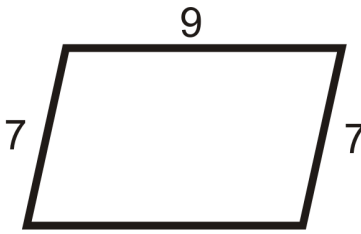
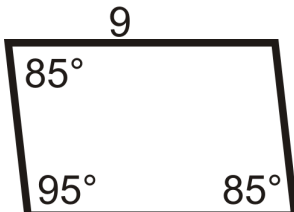
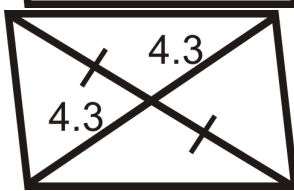
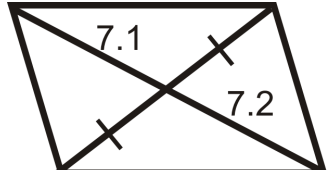
For questions 1-11, determine if the quadrilaterals are parallelograms. If they are, write a reason.

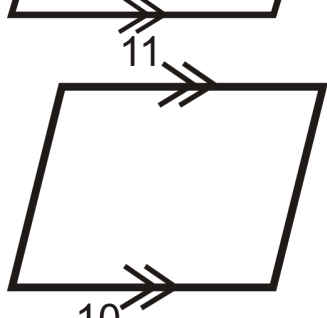
1. 
2. 
3. 
4. 
5. 
6. 
7. 

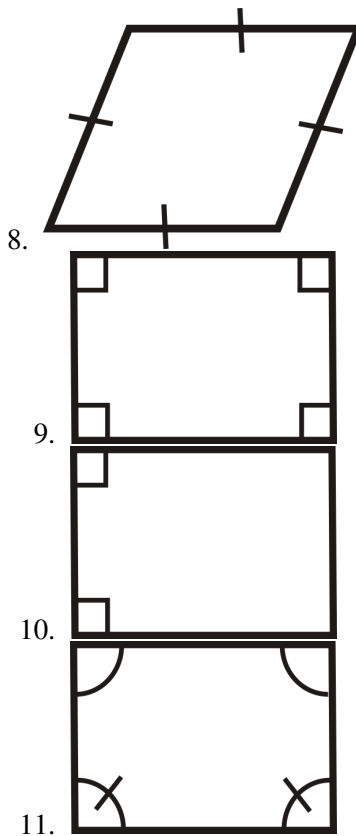

For questions 12-14, determine the value of x and y that would make the quadrilateral a parallelogram.

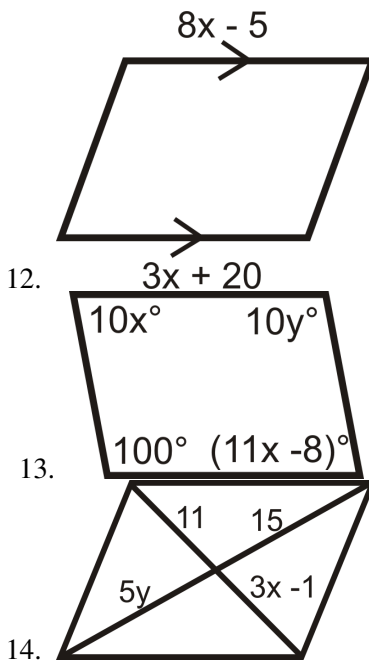

For questions 15-17, determine if $ABCD$ is a parallelogram.

- 15. $A(8, -1), B(6, 5), C(-7, 2), D(-5, -4)$
- 16. $A(-5, 8), B(-2, 9), C(3, 4), D(0, 3)$
- 17. $A(-2, 6), B(4, -4), C(13, -7), D(4, -10)$

Write a two-column proof.

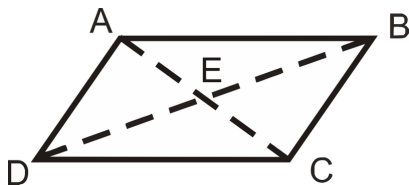
18. *Parallelogram Diagonals Theorem Converse*

Given: $\overline{AE} \cong \overline{EC}$, $\overline{DE} \cong \overline{EB}$ Prove: $ABCD$ is a parallelogram

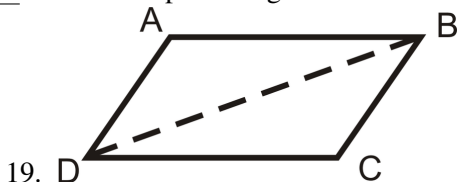

19. Given: $\angle ADB \cong \angle CBD$, $\overline{AD} \cong \overline{BC}$ Prove: $ABCD$ is a parallelogram

Suppose that $A(-2, 3)$, $B(3, 3)$ and $C(1, -3)$ are three of four vertices of a parallelogram.

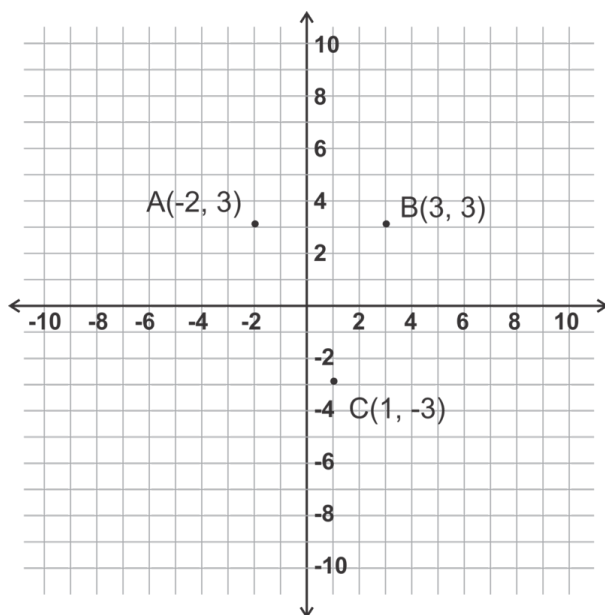

20. Depending on where you choose to put point D , the name of the parallelogram you draw will change. Sketch a picture to show all possible parallelograms. How many can you draw?
21. If you know the parallelogram is named $ABDC$, what is the slope of side parallel to \overline{AC} ?
22. Again, assuming the parallelogram is named $ABDC$, what is the length of \overline{BD} ?

The points $Q(-1, 1)$, $U(7, 1)$, $A(1, 7)$ and $D(-1, 5)$ are the vertices of quadrilateral $QUAD$. Plot the points on graph paper to complete problems 23-26.

23. Find the midpoints of sides \overline{QU} , \overline{UA} , \overline{AD} and \overline{DQ} . Label them W , X , Y and Z respectively.
24. Connect the midpoints to form quadrilateral $WXYZ$. What does this quadrilateral appear to be?
25. Use slopes to verify your answer to problem 24.
26. Use midpoints to verify your answer to problem 24.

6.5 Parallelogram Classification

Here you'll learn what properties differentiate the three special parallelograms: rhombuses, rectangles, and squares.

What if you were designing a patio for your backyard? You decide to mark it off using your tape measure. Two sides are *21 feet* long and two sides are *28 feet* long. Explain how you would only use the tape measure to make your patio a rectangle. After completing this Concept, you'll be able to answer this question using properties of special parallelograms.

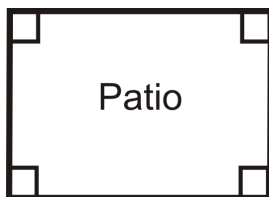

Watch This



MEDIA

Click image to the left for more content.

[CK-12 Foundation: Chapter6ParallelogramClassificationA](#)

Watch the video at this link to learn more about rectangle and square properties.

Follow this link to watch a video about rhombus properties.

Guidance

Rectangles, rhombuses (the plural is also rhombi) and **squares** are all more specific versions of parallelograms.

Rectangle Theorem: A quadrilateral is a rectangle if and only if it has four right (congruent) angles.



Rhombus Theorem: A quadrilateral is a rhombus if and only if it has four congruent sides.

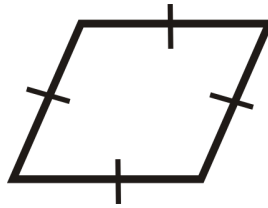

Square Theorem: A quadrilateral is a square if and only if it has four right angles and four congruent sides.

From the Square Theorem, we can also conclude that a *square is a rectangle and a rhombus*.

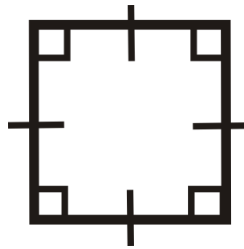

Recall that *diagonals in a parallelogram bisect each other*. Therefore, the diagonals of a rectangle, square and rhombus also bisect each other. The diagonals of these parallelograms also have additional properties.

Investigation: Drawing a Rectangle

Tools Needed: pencil, paper, protractor, ruler

1. Draw two lines on either side of your ruler, to ensure they are parallel. Make these lines 3 inches long.

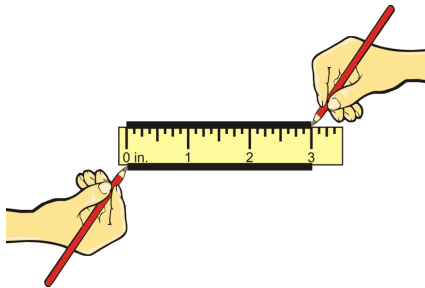

2. Remove the ruler and mark two 90° angles, 2.5 inches apart on the bottom line drawn in Step 1. Then, draw the angles to intersect the top line. This will ensure that all four angles are 90° . Depending on your ruler, the sides should be 2.5 inches and 1 inch.

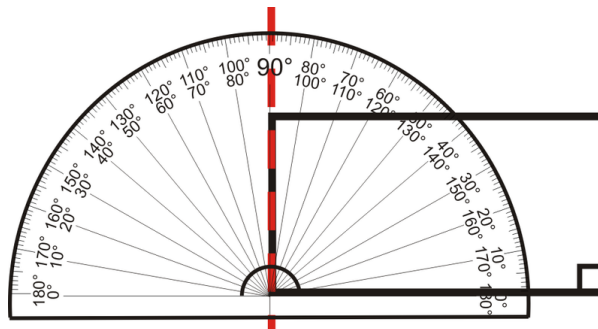

3. Draw in the diagonals and measure them. What do you discover?

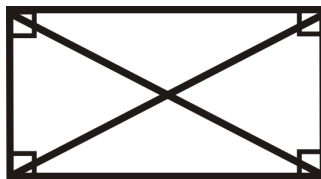

Theorem: A parallelogram is a rectangle if and only if the diagonals are congruent.

Investigation: Drawing a Rhombus

Tools Needed: pencil, paper, protractor, ruler

1. Draw two lines on either side of your ruler, to ensure they are parallel. Make these lines 3 inches long.
2. Remove the ruler and mark a 50° angle, at the left end of the bottom line drawn in Step 1. Draw the other side of the angle and make sure it intersects the top line. Measure the length of this side.



3. The measure of the diagonal (red) side should be about 1.3 inches (if your ruler is 1 inch wide). Mark this length on the bottom line and the top line from the point of intersection with the 50° angle. Draw in the fourth side. It will connect the two endpoints of these lengths.



4. By the way we drew this parallelogram; it is a rhombus because all four sides are 1.3 inches long. Draw in the diagonals.

Measure the angles created by the diagonals: the angles at their point of intersection and the angles created by the sides and each diagonal. You should find the measure of 12 angles total. What do you discover?

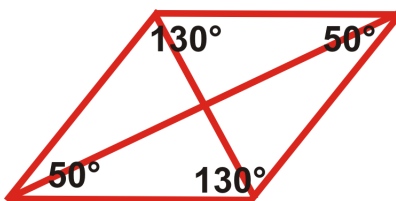

Theorem: A parallelogram is a rhombus if and only if the diagonals are perpendicular.

Theorem: A parallelogram is a rhombus if and only if the diagonals bisect each angle.

We know that a square is a rhombus and a rectangle. So, the diagonals of a square have the properties of a rhombus and a rectangle.

Example A

What type of parallelogram are the ones below?

a)

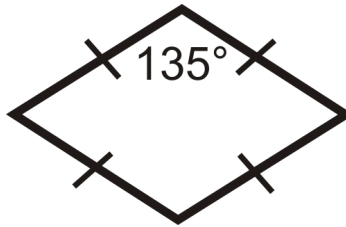

b)

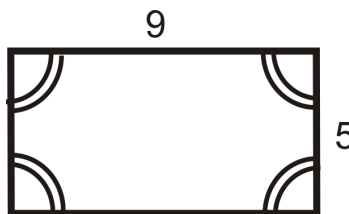
**Answers:**

a) All sides are congruent and one angle is 135° , meaning that the angles are not congruent. By the Rhombus Theorem, this is a rhombus.

b) This quadrilateral has four congruent angles and all the sides are not congruent. By the Rectangle Theorem, this is a rectangle.

Example B

Is a rhombus **SOMETIMES**, **ALWAYS**, or **NEVER** a square? Explain your reasoning.

A rhombus has four congruent sides, while a square has four congruent sides and angles. Therefore, a rhombus is only a square when it also has congruent angles. So, a rhombus is **SOMETIMES** a square.

Example C

List everything you know about the square *SQRE*.

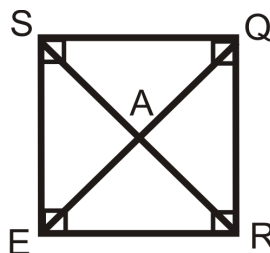

A square has all the properties of a parallelogram, rectangle and rhombus.

TABLE 6.7:

Properties of Parallelograms

- $\overline{SQ} \parallel \overline{ER}$
- $\overline{SE} \parallel \overline{QR}$
- $\overline{SQ} \cong \overline{ER}$
- $\overline{SE} \cong \overline{QR}$
- $\overline{SA} \cong \overline{AR}$
- $\overline{QA} \cong \overline{AE}$
- $\angle SER \cong \angle SQR$
- $\angle QSE \cong \angle QRE$

Properties of Rhombuses

- $\overline{SQ} \cong \overline{ER} \cong \overline{SE} \cong \overline{QR}$
- $\overline{SR} \perp \overline{QE}$
- $\angle SEQ \cong \angle QER \cong \angle SQE \cong \angle EQR$
- $\angle QSR \cong \angle RSE \cong \angle QRS \cong \angle SRE$

Properties of Rectangles

- $\angle SER \cong \angle SQR \cong \angle QSE \cong \angle QRE$
- $\overline{SR} \cong \overline{QE}$
- $\overline{SA} \cong \overline{AR} \cong \overline{QA} \cong \overline{AE}$

Watch this video for help with the Examples above.



MEDIA

Click image to the left for more content.

[CK-12 Foundation: Chapter6ParallelogramClassificationB](#)

Concept Problem Revisited

In order for the patio to be a rectangle, first the opposite sides must be congruent. So, two sides are 21ft and two are 28 ft. To ensure that the parallelogram is a rectangle *without* measuring the angles, the diagonals must be equal.

You can find the length of the diagonals by using the Pythagorean Theorem.

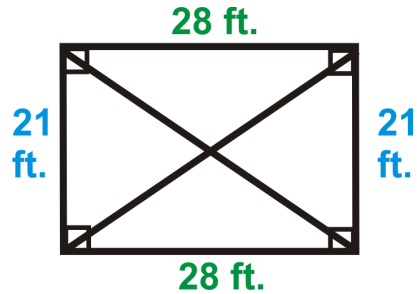

$$d^2 = 21^2 + 28^2 = 441 + 784 = 1225$$

$$d = \sqrt{1225} = 35 \text{ ft}$$

Vocabulary

A **parallelogram** is a quadrilateral with two pairs of parallel sides.

A quadrilateral is a **rectangle** if and only if it has four right (congruent) angles:

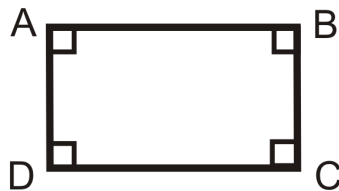

A quadrilateral is a **rhombus** if and only if it has four congruent sides:

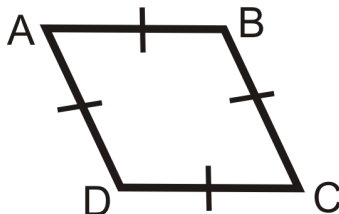

A quadrilateral is a **square** if and only if it has four right angles and four congruent sides.

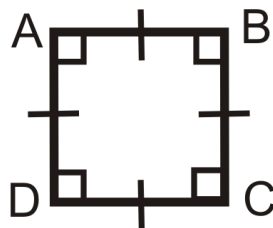

Guided Practice

1. Is a rectangle **SOMETIMES**, **ALWAYS**, or **NEVER** a parallelogram? Explain why.

- Is a rhombus **SOMETIMES**, **ALWAYS**, or **NEVER** equiangular? Explain why.
- Is a quadrilateral **SOMETIMES**, **ALWAYS**, or **NEVER** a pentagon? Explain why.

Answers:

- A rectangle has two sets of parallel sides, so it is **ALWAYS** a parallelogram.
- Any quadrilateral, including a rhombus, is only equiangular if all its angles are 90° . This means a rhombus is **SOMETIMES** equiangular, only when it is a square.
- A quadrilateral has four sides, so it will **NEVER** be a pentagon with five sides.

Practice

- $RACE$ is a rectangle. Find:

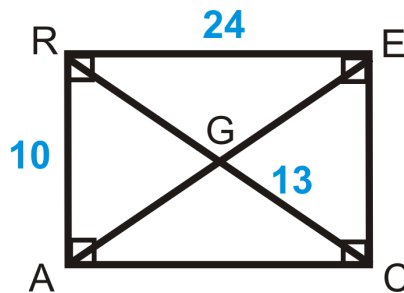

- RG
 - AE
 - AC
 - EC
 - $m\angle RAC$
- $DIAM$ is a rhombus. Find:

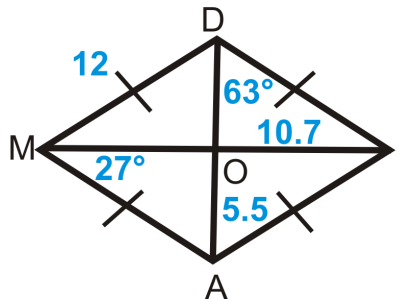

- MA
 - MI
 - DA
 - $m\angle DIA$
 - $m\angle MOA$
- Draw a square and label it $CUBE$. Mark the point of intersection of the diagonals Y . Find:
 - $m\angle UCE$
 - $m\angle EYB$
 - $m\angle UBY$
 - $m\angle UEB$

For questions 4-12, determine if the quadrilateral is a parallelogram, rectangle, rhombus, square or none. Explain your reasoning.

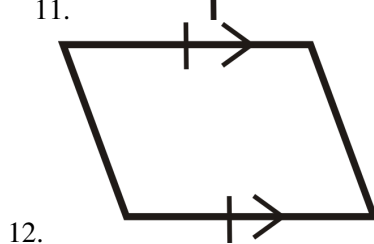
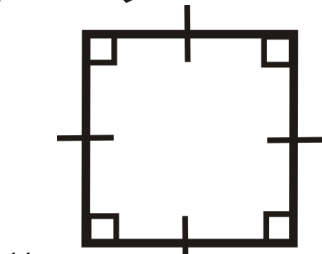
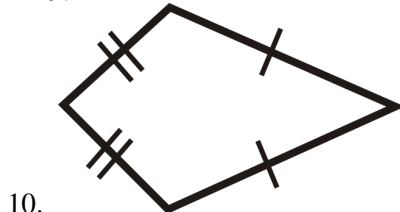
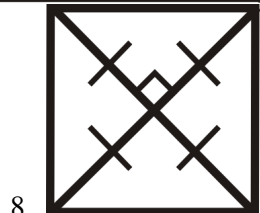
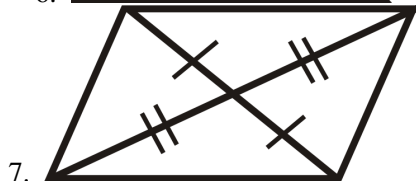
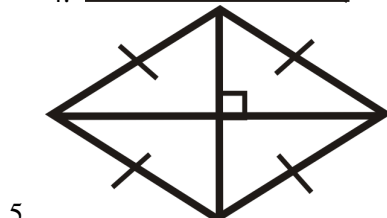
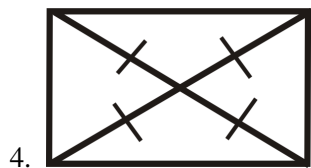

For problems 13-15, find the value of each variable in the figures.

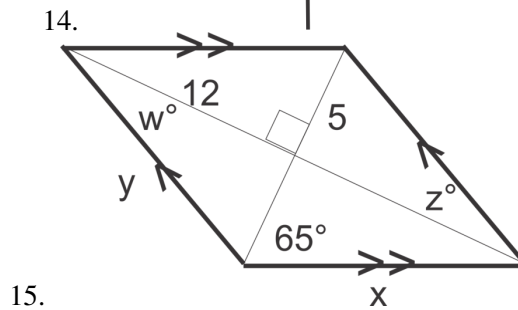
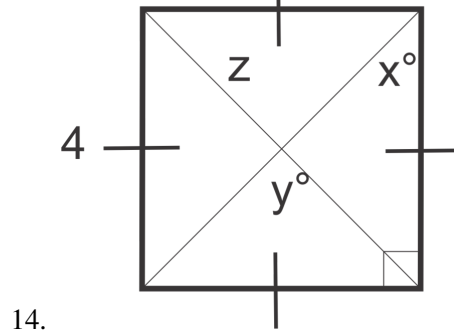
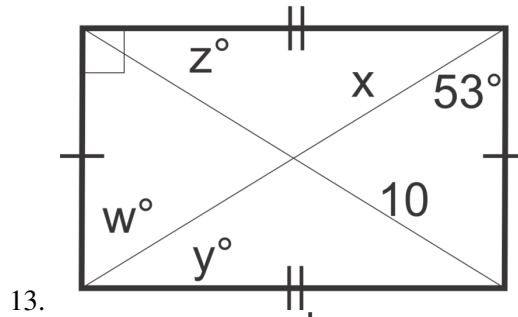

For questions 16-19 determine if the following are ALWAYS, SOMETIMES, or NEVER true. Explain your reasoning.

- 16. A rectangle is a rhombus.
- 17. A square is a parallelogram.
- 18. A parallelogram is regular.
- 19. A square is a rectangle.

6.6 Trapezoids

Here you'll learn the properties of trapezoids and how to apply them.

What if you were told that the polygon ABCD is an isosceles trapezoid and that one of its base angles measures 38° ? What can you conclude about its other angles? After completing this Concept, you'll be able to find the value of a trapezoid's unknown angles and sides given your knowledge of the properties of trapezoids.

Watch This



MEDIA

Click image to the left for more content.

CK-12 Foundation: Chapter6TrapezoidsA

Learn more about trapezoid properties by watching the video at this link.

Guidance

A **trapezoid** is a quadrilateral with exactly one pair of parallel sides. Examples look like:

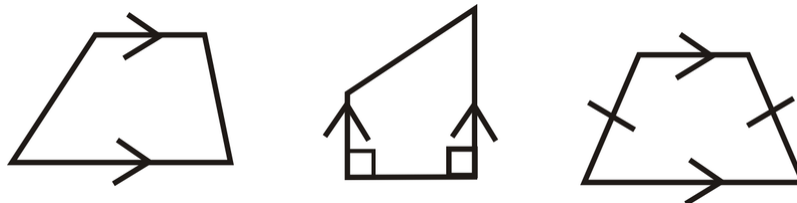

An **isosceles trapezoid** is a trapezoid where the non-parallel sides are congruent. The third trapezoid above is an example of an isosceles trapezoid. Think of it as an isosceles triangle with the top cut off. Isosceles trapezoids also have parts that are labeled much like an isosceles triangle. Both parallel sides are called bases.

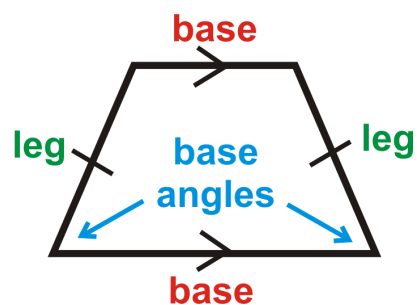

Recall that in an isosceles triangle, the two base angles are congruent. This property holds true for isosceles trapezoids.

Theorem: The base angles of an isosceles trapezoid are congruent.

The converse is also true: If a trapezoid has congruent base angles, then it is an isosceles trapezoid. Next, we will investigate the diagonals of an isosceles trapezoid. Recall, that the diagonals of a rectangle are congruent AND they bisect each other. The diagonals of an isosceles trapezoid are also congruent, but they do NOT bisect each other.

Isosceles Trapezoid Diagonals Theorem: The diagonals of an isosceles trapezoid are congruent.

The **midsegment (of a trapezoid)** is a line segment that connects the midpoints of the non-parallel sides. There is only one midsegment in a trapezoid. It will be parallel to the bases because it is located halfway between them. Similar to the midsegment in a triangle, where it is half the length of the side it is parallel to, the midsegment of a trapezoid also has a link to the bases.

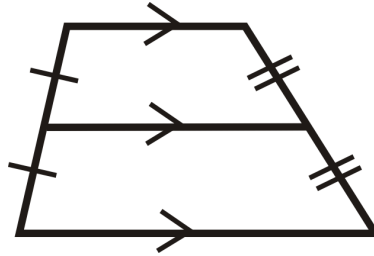

Investigation: Midsegment Property

Tools Needed: graph paper, pencil, ruler

1. Draw a trapezoid on your graph paper with vertices $A(-1,5)$, $B(2,5)$, $C(6,1)$ and $D(-3,1)$. Notice this is NOT an isosceles trapezoid.

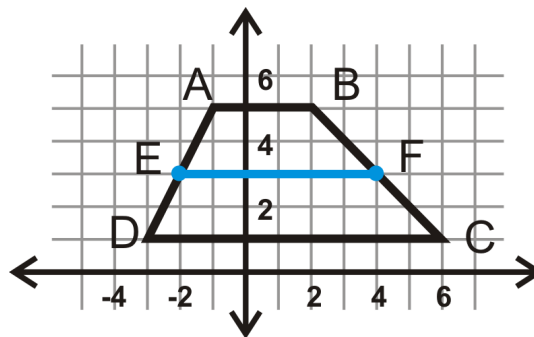

2. Find the midpoint of the non-parallel sides either by using slopes or the midpoint formula. Label them E and F . Connect the midpoints to create the midsegment.
3. Find the lengths of AB , EF , and CD . Can you write a formula to find the midsegment?

Midsegment Theorem: The length of the midsegment of a trapezoid is the average of the lengths of the bases, or $EF = \frac{AB+CD}{2}$.

Example A

Look at trapezoid $TRAP$ below. What is $m\angle A$?

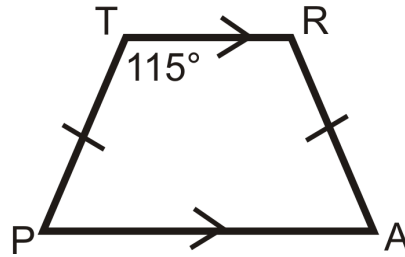

$TRAP$ is an isosceles trapezoid. So, $m\angle R = 115^\circ$. To find $m\angle A$, set up an equation.

$$\begin{aligned} 115^\circ + 115^\circ + m\angle A + m\angle P &= 360^\circ \\ 230^\circ + 2m\angle A &= 360^\circ \rightarrow m\angle A = m\angle P \\ 2m\angle A &= 130^\circ \\ m\angle A &= 65^\circ \end{aligned}$$

Notice that $m\angle R + m\angle A = 115^\circ + 65^\circ = 180^\circ$. These angles will always be supplementary because of the Consecutive Interior Angles Theorem. Therefore, the two angles along the same leg (or non-parallel side) are always going to be supplementary. Only in isosceles trapezoids will opposite angles also be supplementary.

Example B

Write a two-column proof.

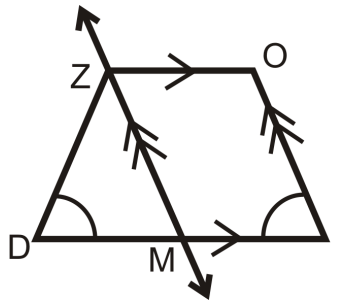

Given: Trapezoid $ZOID$ and parallelogram $ZOIM$

$\angle D \cong \angle I$

Prove: $\overline{ZD} \cong \overline{OI}$

TABLE 6.8:

Statement

1. Trapezoid $ZOID$ and parallelogram $ZOIM$, $\angle D \cong \angle I$
2. $\overline{ZM} \cong \overline{OI}$
3. $\angle I \cong \angle ZMD$
4. $\angle D \cong \angle ZMD$
5. $\overline{ZM} \cong \overline{ZD}$
6. $\overline{ZD} \cong \overline{OI}$

Reason

- Given
 Opposite Sides Theorem
 Corresponding Angles Postulate
 Transitive PoC
 Base Angles Converse
 Transitive PoC

Example C

Find x . All figures are trapezoids with the midsegment.

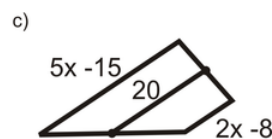
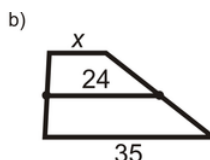
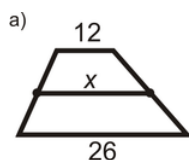
**Answers:**

1. a) x is the average of 12 and 26. $\frac{12+26}{2} = \frac{38}{2} = 19$

b) 24 is the average of x and 35.

$$\begin{aligned}\frac{x+35}{2} &= 24 \\ x+35 &= 48 \\ x &= 13\end{aligned}$$

c) 20 is the average of $5x - 15$ and $2x - 8$.

$$\begin{aligned}\frac{5x-15+2x-8}{2} &= 20 \\ 7x-23 &= 40 \\ 7x &= 63 \\ x &= 9\end{aligned}$$

Watch this video for help with the Examples above.

**MEDIA**

Click image to the left for more content.

[CK-12 Foundation: Chapter6TrapezoidsB](#)

Concept Problem Revisited

Given an isosceles trapezoid with $m\angle B = 38^\circ$, find the missing angles.

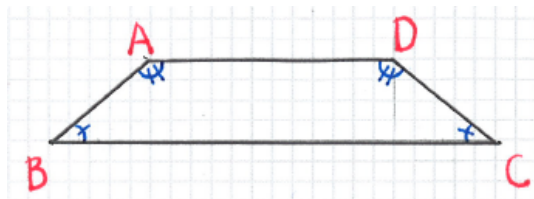

In an isosceles trapezoid, base angles are congruent.

$$\angle B \cong \angle C \text{ and } \angle A \cong \angle D$$

$$\begin{aligned} m\angle B &= m\angle C = 38^\circ \\ 38^\circ + 38^\circ + m\angle A + m\angle D &= 360^\circ \\ m\angle A &= m\angle D = 142^\circ \end{aligned}$$

Vocabulary

A **trapezoid** is a quadrilateral with exactly one pair of parallel sides. An **isosceles trapezoid** is a trapezoid where the non-parallel sides and base angles are congruent. The **midsegment (of a trapezoid)** is a line segment that connects the midpoints of the non-parallel sides.

Guided Practice

TRAP an isosceles trapezoid.

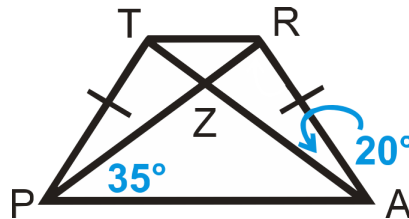

Find:

1. $m\angle TPA$
2. $m\angle PTR$
3. $m\angle PZA$
4. $m\angle ZRA$

Answers:

1. $\angle TPZ \cong \angle RAZ$ so $m\angle TPA = 20^\circ + 35^\circ = 55^\circ$.
2. $\angle TPA$ is supplementary with $\angle PTR$, so $m\angle PTR = 125^\circ$.
3. By the Triangle Sum Theorem, $35^\circ + 35^\circ + m\angle PZA = 180^\circ$, so $m\angle PZA = 110^\circ$.
4. Since $m\angle PZA = 110^\circ$, $m\angle RZA = 70^\circ$ because they form a linear pair. By the Triangle Sum Theorem, $m\angle ZRA = 90^\circ$.

Practice

1. Can the parallel sides of a trapezoid be congruent? Why or why not?

For questions 2-7, find the length of the midsegment or missing side.

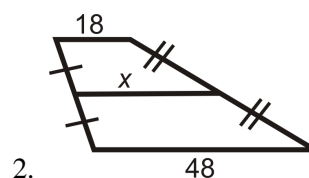

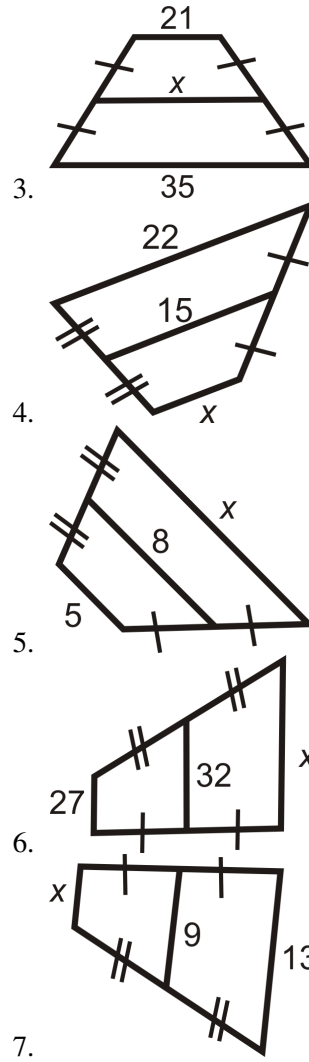

Find the value of the missing variable(s).

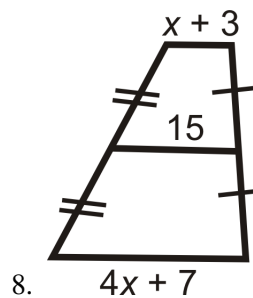

Find the lengths of the diagonals of the trapezoids below to determine if it is isosceles.

- 9. $A(-3, 2), B(1, 3), C(3, -1), D(-4, -2)$
- 10. $A(-3, 3), B(2, -2), C(-6, -6), D(-7, 1)$
- 11. $A(1, 3), B(4, 0), C(2, -4), D(-3, 1)$
- 12. $A(1, 3), B(3, 1), C(2, -4), D(-3, 1)$

13. Write a two-column proof of the Isosceles Trapezoid Diagonals Theorem using congruent triangles.

Given: $TRAP$ is an isosceles trapezoid with $\overline{TR} \parallel \overline{AP}$.

Prove: $\overline{TA} \cong \overline{RP}$

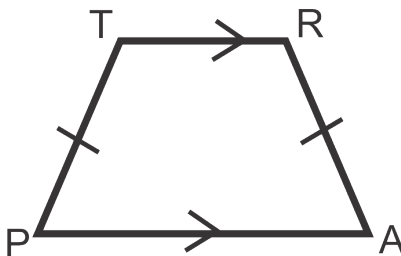

14. How are the opposite angles in an isosceles trapezoid related?
15. List all the properties of a trapezoid.

6.7 Kites

Here you'll learn the properties of kites and how to apply them.

What if you made a traditional kite, seen below, by placing two pieces of wood perpendicular to each other (one bisected by the other)? The typical dimensions are included in the picture. If you have two pieces of wood, 36 inches and 54 inches, determine the values of x and $2x$. Then, determine how large a piece of canvas you would need to make the kite (find the perimeter of the kite). After completing this Concept, you'll be able to answer these questions using your knowledge of kites.

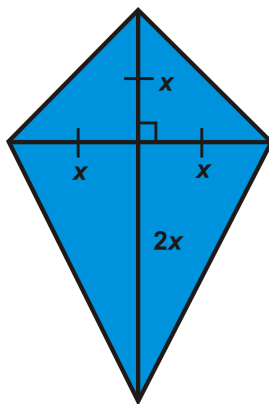

Watch This



MEDIA

Click image to the left for more content.

CK-12 Foundation: [Chapter6KitesA](#)

Learn more aboutkite propertiesby watchingthevideo at this link.

Guidance

A **kite** is a quadrilateral with two sets of distinct, adjacent congruent sides. A few examples:

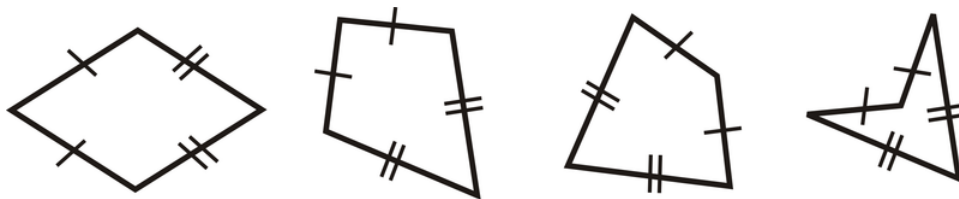

From the definition, a kite is the only quadrilateral that we have discussed that could be concave, as with the case of the last kite. If a kite is concave, it is called a *dart*. The angles between the congruent sides are called *vertex angles*.

The other angles are called *non-vertex angles*. If we draw the diagonal through the vertex angles, we would have two congruent triangles.

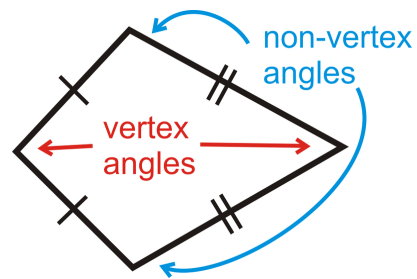

Theorem: The non-vertex angles of a kite are congruent.

Proof:

Given: $KITE$ with $\overline{KE} \cong \overline{TE}$ and $\overline{KI} \cong \overline{TI}$

Prove: $\angle K \cong \angle T$

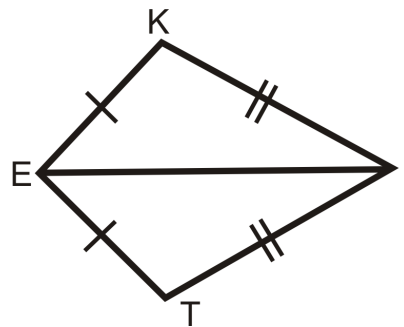

TABLE 6.9:

Statement

1. $\overline{KE} \cong \overline{TE}$ and $\overline{KI} \cong \overline{TI}$
2. $\overline{EI} \cong \overline{EI}$
3. $\triangle KEI \cong \triangle TEI$
4. $\angle K \cong \angle T$

Reason

- Given
 Reflexive PoC
 SSS
 CPCTC

Theorem: The diagonal through the vertex angles is the angle bisector for both angles.

The proof of this theorem is very similar to the proof above for the first theorem. If we draw in the other diagonal in $KITE$ we find that the two diagonals are perpendicular.

Kite Diagonals Theorem: The diagonals of a kite are perpendicular.

To prove that the diagonals are perpendicular, look at $\triangle KET$ and $\triangle KIT$. Both of these triangles are isosceles triangles, which means \overline{EI} is the perpendicular bisector of \overline{KT} (the Isosceles Triangle Theorem). Use this information to help you prove the diagonals are perpendicular in the practice questions.

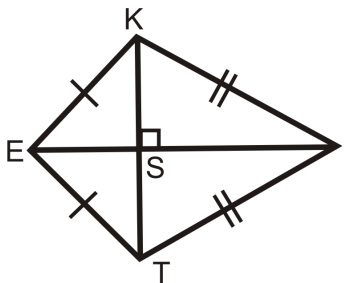

Example A

Find the other two angle measures in the kite below.

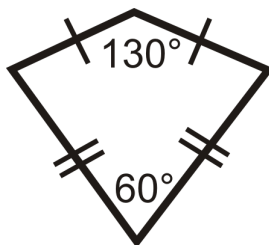

The two angles left are the non-vertex angles, which are congruent.

$$\begin{aligned}
 130^\circ + 60^\circ + x + x &= 360^\circ \\
 2x &= 170^\circ \\
 x &= 85^\circ \quad \text{Both angles are } 85^\circ.
 \end{aligned}$$

Example B

Use the Pythagorean Theorem to find the length of the sides of the kite.

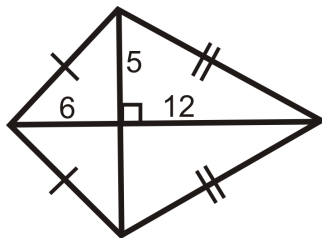

Recall that the Pythagorean Theorem is $a^2 + b^2 = c^2$, where c is the hypotenuse. In this kite, the sides are all hypotenuses.

$$\begin{aligned}
 6^2 + 5^2 &= h^2 & 12^2 + 5^2 &= j^2 \\
 36 + 25 &= h^2 & 144 + 25 &= j^2 \\
 61 &= h^2 & 169 &= j^2 \\
 \sqrt{61} &= h & 13 &= j
 \end{aligned}$$

Example C

Find the other two angle measures in the kite below.

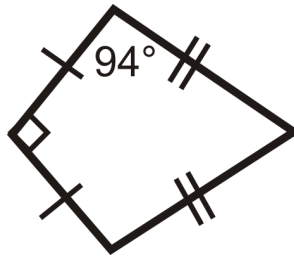

The other non-vertex angle is also 94° . To find the fourth angle, subtract the other three angles from 360° .

$$\begin{aligned} 90^\circ + 94^\circ + 94^\circ + x &= 360^\circ \\ x &= 82^\circ \end{aligned}$$

Watch this video for help with the Examples above.



MEDIA

Click image to the left for more content.

[CK-12 Foundation: Chapter6KitesB](#)

Concept Problem Revisited

If the diagonals (pieces of wood) are 36 inches and 54 inches, x is half of 36, or 18 inches. Then, $2x$ is 36. To determine how large a piece of canvas to get, find the length of each side of the kite using the Pythagorean Theorem.

$$\begin{aligned} 18^2 + 18^2 &= s^2 \\ 324 &= s^2 \\ 18\sqrt{2} &\approx 25.5 \approx s \end{aligned}$$

$$\begin{aligned} 18^2 + 36^2 &= t^2 \\ 1620 &= t^2 \\ 18\sqrt{5} &\approx 40.25 \approx t \end{aligned}$$

The perimeter of the kite would be $25.5 + 25.5 + 40.25 + 40.25 = 131.5$ inches or 11 ft, 10.5 in.

Vocabulary

A **kite** is a quadrilateral with two distinct sets of adjacent congruent sides. The angles between the congruent sides are called **vertex angles**. The other angles are called **non-vertex angles**.

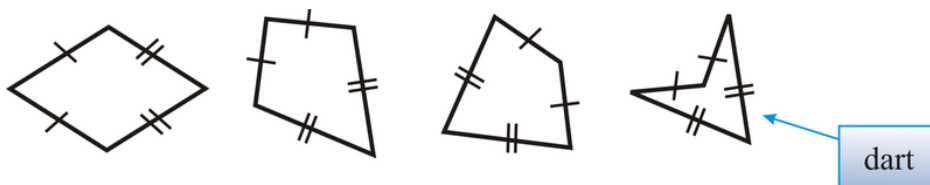

If a kite is concave, it is called a *dart*.

Guided Practice

KITE is a kite.

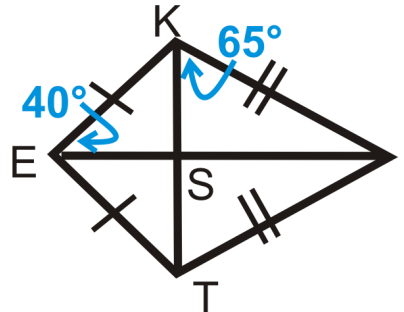

Find:

1. $m\angle KIS$
2. $m\angle IST$
3. $m\angle SIT$

Answers:

1. $m\angle KIS = 25^\circ$ by the Triangle Sum Theorem (remember that $\angle KSI$ is a right angle because the diagonals are perpendicular.)
2. $m\angle IST = 90^\circ$ because the diagonals are perpendicular.
3. $m\angle SIT = 25^\circ$ because it is congruent to $\angle KIS$.

Practice

For questions 1-6, find the value of the missing variable(s). All figures are kites.

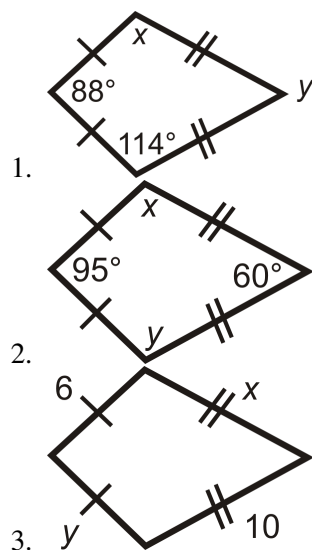

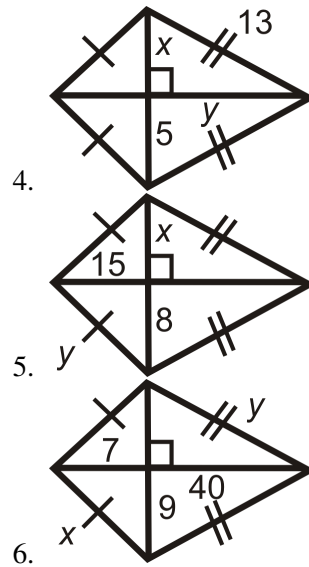

For questions 7-11, find the value of the missing variable(s).

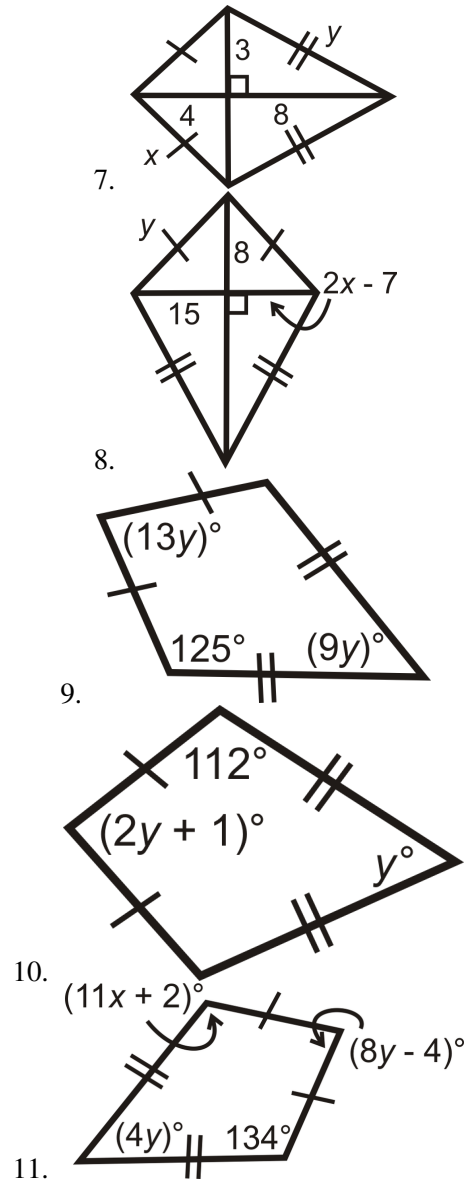

12. Prove that the long diagonal of a kite bisects its angles.

Given: $\overline{KE} \cong \overline{TE}$ and $\overline{KI} \cong \overline{TI}$

Prove: \overline{EI} is the angle bisector of $\angle KET$ and $\angle KIT$

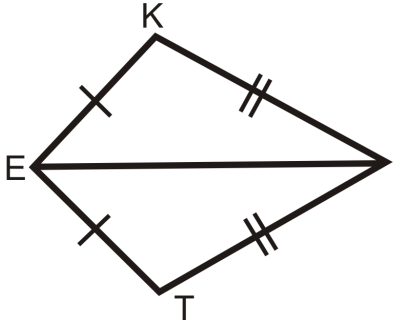

13. Prove the Kite Diagonal Theorem.

Given: $\overline{EK} \cong \overline{ET}$, $\overline{KI} \cong \overline{IT}$

Prove: $\overline{KT} \perp \overline{EI}$

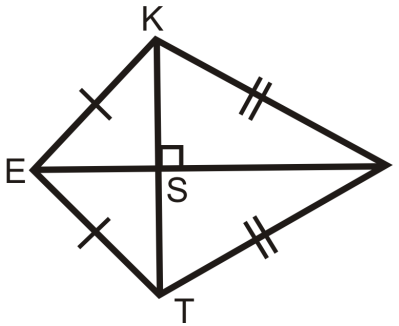

14. **Writing** Besides a kite and a rhombus, can you find another quadrilateral with perpendicular diagonals? Explain and draw a picture.

15. **Writing** Describe how you would draw or construct a kite.

6.8 Quadrilateral Classification

Here you'll learn how to classify quadrilaterals in the coordinate plane.

What if you were given a quadrilateral in the coordinate plane? How could you determine if that quadrilateral qualifies as one of the special quadrilaterals: parallelograms, squares, rectangles, rhombuses, kites, or trapezoids? After completing this Concept, you'll be able to make such a determination.

Watch This



MEDIA

Click image to the left for more content.

CK-12 Foundation: Chapter6QuadrilateralClassificationA

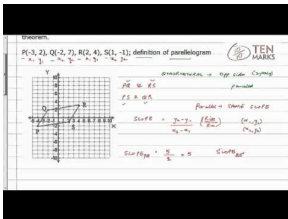

MEDIA

Click image to the left for more content.

Ten Marks: Parallelograms in a Coordinate Plane

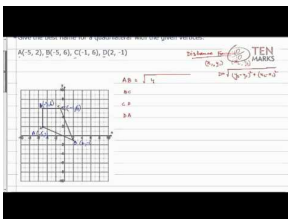

MEDIA

Click image to the left for more content.

Ten Marks: Kites and Trapezoids

Guidance

When working in the coordinate plane, you will sometimes want to know what type of shape a given shape is. You should easily be able to tell that it is a quadrilateral if it has four sides. But how can you classify it beyond that?

First you should graph the shape if it has not already been graphed. Look at it and see if it looks like any special quadrilateral. Do the sides appear to be congruent? Do they meet at right angles? This will give you a place to start.

Once you have a guess for what type of quadrilateral it is, your job is to prove your guess. To prove that a quadrilateral is a parallelogram, rectangle, rhombus, square, kite or trapezoid, you must show that it meets the definition of that shape OR that it has properties that only that shape has.

If it turns out that your guess was wrong because the shape does not fulfill the necessary properties, you can guess again. If it appears to be no type of special quadrilateral then it is simply a *quadrilateral*.

The examples below will help you to see what this process might look like.

Example A

Determine what type of parallelogram $TUNE$ is: $T(0, 10)$, $U(4, 2)$, $N(-2, -1)$, and $E(-6, 7)$.

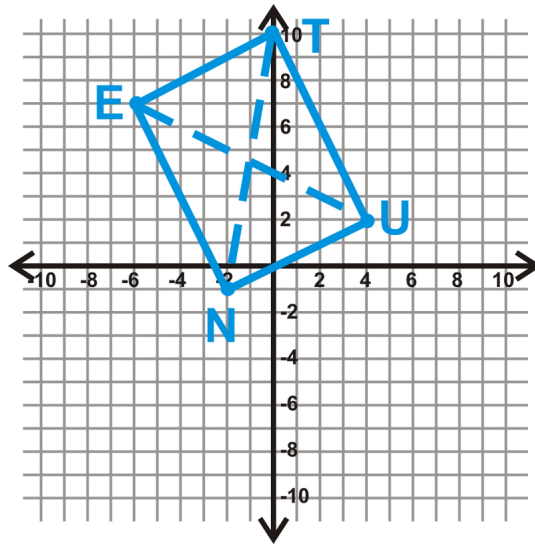

This *looks* like a rectangle. Let's see if the diagonals are equal. If they are, then $TUNE$ is a rectangle.

$$\begin{aligned} EU &= \sqrt{(-6-4)^2 + (7-2)^2} \\ &= \sqrt{(-10)^2 + 5^2} \\ &= \sqrt{100 + 25} \\ &= \sqrt{125} \end{aligned}$$

$$\begin{aligned} TN &= \sqrt{(0+2)^2 + (10+1)^2} \\ &= \sqrt{2^2 + 11^2} \\ &= \sqrt{4 + 121} \\ &= \sqrt{125} \end{aligned}$$

If the diagonals are also perpendicular, then $TUNE$ is a square.

$$\text{Slope of } EU = \frac{7-2}{-6-4} = -\frac{5}{10} = -\frac{1}{2} \quad \text{Slope of } TN = \frac{10-(-1)}{0-(-2)} = \frac{11}{2}$$

The slope of $EU \neq$ slope of TN , so $TUNE$ is a rectangle.

Example B

A quadrilateral is defined by the four lines $y = 2x + 1$, $y = -x + 5$, $y = 2x - 4$, and $y = -x - 5$. Is this quadrilateral a parallelogram?

To check if its a parallelogram we have to check that it has two pairs of parallel sides. From the equations we can see that the slopes of the lines are 2, -1 , 2 and -1 . Because two pairs of slopes match, this shape has two pairs of parallel sides and is a parallelogram.

Example C

Determine what type of quadrilateral $RSTV$ is. Simplify all radicals.

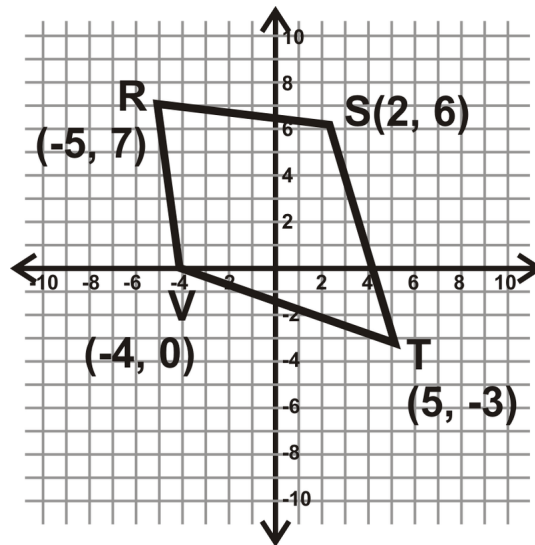

There are two directions you could take here. First, you could determine if the diagonals bisect each other. If they do, then it is a parallelogram. Or, you could find the lengths of all the sides. Let's do this option.

$$\begin{aligned} RS &= \sqrt{(-5-2)^2 + (7-6)^2} \\ &= \sqrt{(-7)^2 + 1^2} \\ &= \sqrt{50} = 5\sqrt{2} \end{aligned}$$

$$\begin{aligned} ST &= \sqrt{(2-5)^2 + (6-(-3))^2} \\ &= \sqrt{(-3)^2 + 9^2} \\ &= \sqrt{90} = 3\sqrt{10} \end{aligned}$$

$$\begin{aligned} RV &= \sqrt{(-5-(-4))^2 + (7-0)^2} \\ &= \sqrt{(-1)^2 + 7^2} \\ &= \sqrt{50} = 5\sqrt{2} \end{aligned}$$

$$\begin{aligned} VT &= \sqrt{(-4-5)^2 + (0-(-3))^2} \\ &= \sqrt{(-9)^2 + 3^2} \\ &= \sqrt{90} = 3\sqrt{10} \end{aligned}$$

From this we see that the adjacent sides are congruent. Therefore, $RSTV$ is a kite.

Algebra Review: When asked to “simplify the radical,” pull all square numbers (1, 4, 9, 16, 25, ...) out of the radical. Above $\sqrt{50} = \sqrt{25 \cdot 2}$. We know $\sqrt{25} = 5$, so $\sqrt{50} = \sqrt{25 \cdot 2} = 5\sqrt{2}$.

Watch this video for help with the Examples above.

**MEDIA**

Click image to the left for more content.

Example D

Is the quadrilateral $ABCD$ a parallelogram?

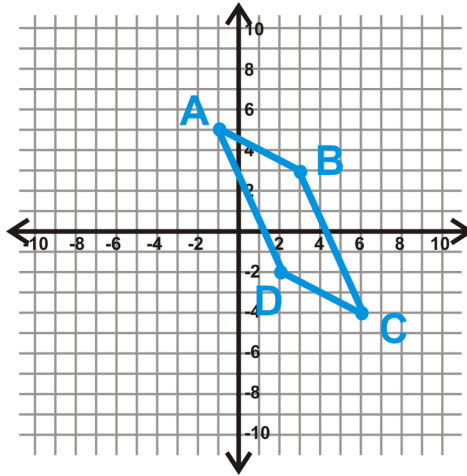

We have determined there are four different ways to show a quadrilateral is a parallelogram in the $x - y$ plane. Let's check if a pair of opposite sides are congruent and parallel. First, find the length of AB and CD .

$$\begin{aligned} AB &= \sqrt{(-1-3)^2 + (5-3)^2} \\ &= \sqrt{(-4)^2 + 2^2} \\ &= \sqrt{16+4} \\ &= \sqrt{20} \end{aligned}$$

$$\begin{aligned} CD &= \sqrt{(2-6)^2 + (-2+4)^2} \\ &= \sqrt{(-4)^2 + 2^2} \\ &= \sqrt{16+4} \\ &= \sqrt{20} \end{aligned}$$

$AB = CD$, so if the two lines have the same slope, $ABCD$ is a parallelogram.

$$\text{Slope } AB = \frac{5-3}{-1-3} = \frac{2}{-4} = -\frac{1}{2} \quad \text{Slope } CD = \frac{-2+4}{2-6} = \frac{2}{-4} = -\frac{1}{2}$$

Therefore, $ABCD$ is a parallelogram.

Vocabulary

A **parallelogram** is a quadrilateral with two pairs of parallel sides. A quadrilateral is a **rectangle** if and only if it has four right (congruent) angles. A quadrilateral is a **rhombus** if and only if it has four congruent sides. A quadrilateral is a **square** if and only if it has four right angles and four congruent sides. A **trapezoid** is a quadrilateral with exactly one pair of parallel sides. An **isosceles trapezoid** is a trapezoid where the non-parallel sides are congruent. A **kite** is a quadrilateral with two distinct sets of adjacent congruent sides. If a kite is concave, it is called a **dart**.

Guided Practice

1. A quadrilateral is defined by the four lines $y = 2x + 1$, $y = -2x + 5$, $y = 2x - 4$, and $y = -2x - 5$. Is this quadrilateral a rectangle?
2. Determine what type of quadrilateral $ABCD$ is. $A(-3, 3)$, $B(1, 5)$, $C(4, -1)$, $D(1, -5)$. Simplify all radicals.
3. Determine what type of quadrilateral $EFGH$ is. $E(5, -1)$, $F(11, -3)$, $G(5, -5)$, $H(-1, -3)$

Answers:

1. To be a rectangle a shape must have four right angles. This means that the sides must be perpendicular to each other. From the given equations we see that the slopes are 2, -2 , 2 and -2 . Because the slopes are not opposite reciprocals of each other, the sides are not perpendicular, and the shape is not a rectangle.

2. First, graph $ABCD$. This will make it easier to figure out what type of quadrilateral it is. From the graph, we can tell this is not a parallelogram. Find the slopes of \overline{BC} and \overline{AD} to see if they are parallel.

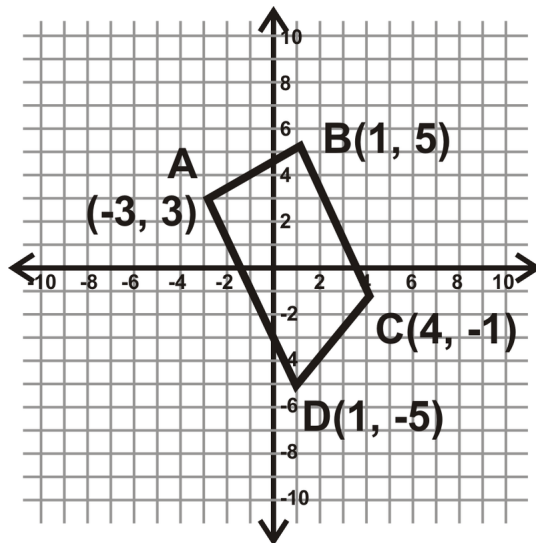

$$\text{Slope of } \overline{BC} = \frac{5 - (-1)}{1 - 4} = \frac{6}{-3} = -2$$

$$\text{Slope of } \overline{AD} = \frac{3 - (-5)}{-3 - 1} = \frac{8}{-4} = -2$$

We now know $\overline{BC} \parallel \overline{AD}$. This is a trapezoid. To determine if it is an isosceles trapezoid, find AB and CD .

$$\begin{aligned} AB &= \sqrt{(-3 - 1)^2 + (3 - 5)^2} \\ &= \sqrt{(-4)^2 + (-2)^2} \\ &= \sqrt{20} = 2\sqrt{5} \end{aligned}$$

$$\begin{aligned} ST &= \sqrt{(4 - 1)^2 + (-1 - (-5))^2} \\ &= \sqrt{3^2 + 4^2} \\ &= \sqrt{25} = 5 \end{aligned}$$

$AB \neq CD$, therefore this is only a trapezoid.

3. We will not graph this example. Let's find the length of all four sides.

$$\begin{aligned} EF &= \sqrt{(5 - 11)^2 + (-1 - (-3))^2} \\ &= \sqrt{(-6)^2 + 2^2} \\ &= \sqrt{40} = 2\sqrt{10} \end{aligned}$$

$$\begin{aligned} FG &= \sqrt{(11 - 5)^2 + (-3 - (-5))^2} \\ &= \sqrt{6^2 + 2^2} \\ &= \sqrt{40} = 2\sqrt{10} \end{aligned}$$

$$\begin{aligned} GH &= \sqrt{(5 - (-1))^2 + (-5 - (-3))^2} \\ &= \sqrt{6^2 + (-2)^2} \\ &= \sqrt{40} = 2\sqrt{10} \end{aligned}$$

$$\begin{aligned} HE &= \sqrt{(-1 - 5)^2 + (-3 - (-1))^2} \\ &= \sqrt{(-6)^2 + (-2)^2} \\ &= \sqrt{40} = 2\sqrt{10} \end{aligned}$$

All four sides are equal. That means, this quadrilateral is either a rhombus or a square. The difference between the two is that a square has four 90° angles and congruent diagonals. Let's find the length of the diagonals.

$$\begin{aligned} EG &= \sqrt{(5-5)^2 + (-1-(-5))^2} \\ &= \sqrt{0^2 + 4^2} \\ &= \sqrt{16} = 4 \end{aligned}$$

$$\begin{aligned} FH &= \sqrt{(11-(-1))^2 + (-3-(-3))^2} \\ &= \sqrt{12^2 + 0^2} \\ &= \sqrt{144} = 12 \end{aligned}$$

The diagonals are not congruent, so $EFGH$ is a rhombus.

Practice

1. If a quadrilateral has exactly one pair of parallel sides, what type of quadrilateral is it?
2. If a quadrilateral has two pairs of parallel sides and one right angle, what type of quadrilateral is it?
3. If a quadrilateral has perpendicular diagonals, what type of quadrilateral is it?
4. If a quadrilateral has diagonals that are perpendicular and congruent, what type of quadrilateral is it?
5. If a quadrilateral has four congruent sides and one right angle, what type of quadrilateral is it?

Determine what type of quadrilateral $ABCD$ is.

6. $A(-2, 4), B(-1, 2), C(-3, 1), D(-4, 3)$
7. $A(-2, 3), B(3, 4), C(2, -1), D(-3, -2)$
8. $A(1, -1), B(7, 1), C(8, -2), D(2, -4)$
9. $A(10, 4), B(8, -2), C(2, 2), D(4, 8)$
10. $A(0, 0), B(5, 0), C(0, 4), D(5, 4)$
11. $A(-1, 0), B(0, 1), C(1, 0), D(0, -1)$
12. $A(2, 0), B(3, 5), C(5, 0), D(6, 5)$

$SRUE$ is a rectangle and $PRUC$ is a square.

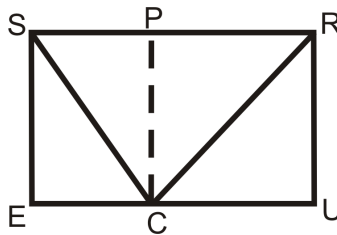

13. What type of quadrilateral is $SPCE$?
14. If $SR = 20$ and $RU = 12$, find CE .
15. Find SC and RC based on the information from part b. Round your answers to the nearest hundredth.

Summary

This chapter starts by introducing interior and exterior angles in polygons. Then, all special types of quadrilaterals are explored and classified, both on and off the coordinate plane.

Chapter Keywords

- Polygon Sum Formula
- Equiangular Polygon Formula
- Regular Polygon
- Exterior Angle Sum Theorem
- Parallelogram
- Opposite Sides Theorem
- Opposite Angles Theorem
- Consecutive Angles Theorem
- Parallelogram Diagonals Theorem
- Opposite Sides Theorem Converse
- Opposite Angles Theorem Converse
- Consecutive Angles Theorem Converse
- Parallelogram Diagonals Theorem Converse
- Rectangle Theorem
- Rhombus Theorem
- Square Theorem
- Trapezoid
- Isosceles Trapezoid
- Isosceles Trapezoid Diagonals Theorem
- Midsegment (of a trapezoid)
- Midsegment Theorem
- Kite
- Kite Diagonals Theorem

Chapter Review

Fill in the flow chart according to what you know about the quadrilaterals we have learned in this chapter.

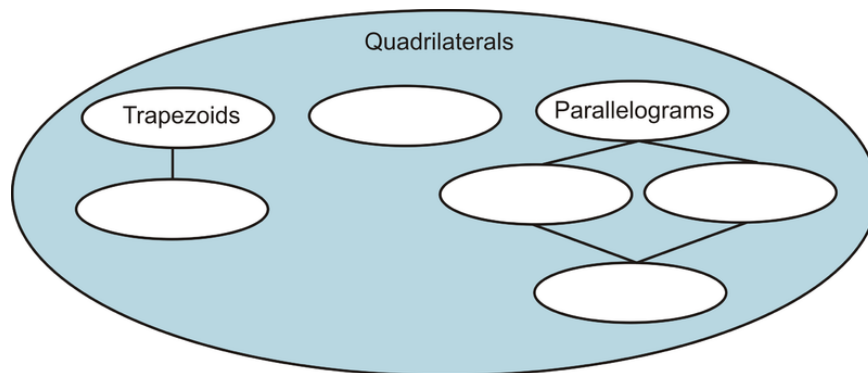

Determine if the following statements are sometimes, always or never true.

1. A trapezoid is a kite.
2. A square is a parallelogram.
3. An isosceles trapezoid is a quadrilateral.
4. A rhombus is a square.
5. A parallelogram is a square.
6. A square is a kite.
7. A square is a rectangle.

8. A quadrilateral is a rhombus.

Table Summary

Determine if each quadrilateral has the given properties. If so, write yes or state how many sides (or angles) are congruent, parallel, or perpendicular.

TABLE 6.10:

| | Opposite sides \parallel | Diagonals bisect each other | Diagonals \perp | Opposite sides \cong | Opposite angles \cong | Consecutive Angles add up to 180° |
|---------------------|----------------------------|-----------------------------|-------------------|------------------------|-------------------------|--|
| Trapezoid | | | | | | |
| Isosceles Trapezoid | | | | | | |
| Kite | | | | | | |
| Parallelogram | | | | | | |
| Rectangle | | | | | | |
| Rhombus | | | | | | |
| Square | | | | | | |

Find the measure of all the lettered angles below. The bottom angle in the pentagon (at the bottom of the drawing) is 138° .

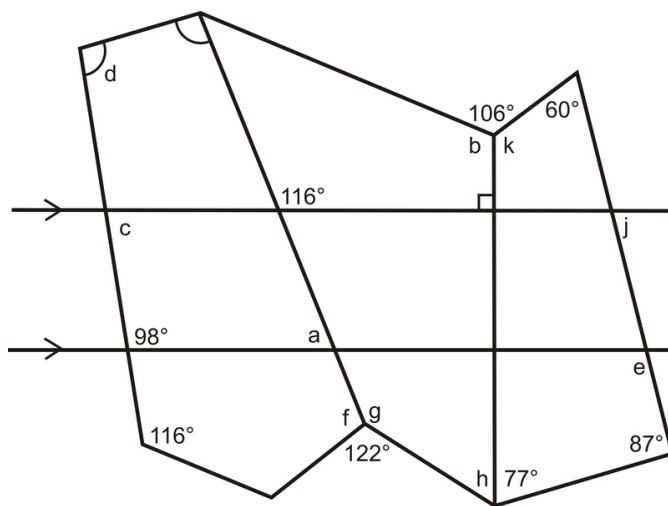

Texas Instruments Resources

In the CK-12 Texas Instruments Geometry FlexBook, there are graphing calculator activities designed to supplement the objectives for some of the lessons in this chapter. See <http://www.ck12.org/flexr/chapter/9691>.

CHAPTER 7**Similarity****Chapter Outline**

- 7.1 FORMS OF RATIOS**
 - 7.2 PROPORTION PROPERTIES**
 - 7.3 SIMILAR POLYGONS AND SCALE FACTORS**
 - 7.4 AA SIMILARITY**
 - 7.5 INDIRECT MEASUREMENT**
 - 7.6 SSS SIMILARITY**
 - 7.7 SAS SIMILARITY**
 - 7.8 TRIANGLE PROPORTIONALITY**
 - 7.9 PARALLEL LINES AND TRANSVERSALS**
 - 7.10 PROPORTIONS WITH ANGLE BISECTORS**
 - 7.11 DILATION**
 - 7.12 DILATION IN THE COORDINATE PLANE**
 - 7.13 SELF-SIMILARITY**
-

Introduction

In this chapter, we will start with a review of ratios and proportions. Second, we will introduce the concept of similarity. Two figures are similar if they have the same shape, but not the same size. We will apply similarity to polygons, quadrilaterals and triangles. Then, we will extend this concept to proportionality with parallel lines and dilations. Finally, there is an extension about self-similarity, or fractals, at the end of the chapter.

7.1 Forms of Ratios

Here you'll learn what a ratio is and the different ways you can write one. You'll also learn how to use ratios to solve problems.

What if you wanted to make a scale drawing of your room and furniture for a little redecorating? Your room measures 12 feet by 12 feet. Also in your room is a twin bed (36 in by 75 in), a desk (4 feet by 2 feet), and a chair (3 feet by 3 feet). You decide to scale down your room to 8 in by 8 in, so the drawing fits on a piece of paper. What size should the bed, desk and chair be? Draw an appropriate layout for the furniture within the room. *Do not round your answers.* After completing this Concept, you'll be able to use ratios to answer this question.

Watch This



MEDIA

Click image to the left for more content.

[CK-12 Foundation: Chapter7FormsofRatiosA](#)

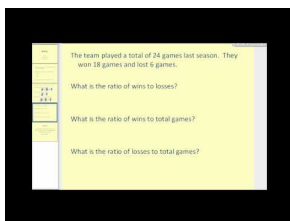

MEDIA

Click image to the left for more content.

[James Sousa:Ratios](#)

Guidance

A **ratio** is a way to compare two numbers. Ratios can be written: $\frac{a}{b}$, $a : b$, and a to b . Let's look at some examples

Example A

There are 12 girls and 15 boys in your math class. What is the ratio of girls to boys?

Remember that order matters. The question asked for the ratio of *girls* to *boys*. The ratio would be 12:15. This can be simplified to 4:5.

Example B

Simplify the following ratios.

a) $\frac{7 \text{ ft}}{14 \text{ in}}$

b) 9m:900cm

c) $\frac{4 \text{ gal}}{16 \text{ gal}}$

First, change each ratio so that each part is in the same units. Remember that there are 12 inches in a foot.

a)

$$\frac{7 \cancel{\text{ft}}}{14 \cancel{\text{in}}} \cdot \frac{12 \cancel{\text{in}}}{1 \cancel{\text{ft}}} = \frac{84}{14} = \frac{6}{1}$$

The inches and feet cancel each other out. **Simplified ratios do not have units.**

b) It is easier to simplify a ratio when written as a fraction.

$$\frac{9 \cancel{\text{m}}}{900 \cancel{\text{cm}}} \cdot \frac{100 \cancel{\text{cm}}}{1 \cancel{\text{m}}} = \frac{900}{900} = \frac{1}{1}$$

c)

$$\frac{4 \cancel{\text{gal}}}{16 \cancel{\text{gal}}} = \frac{1}{4}$$

Example C

A talent show has dancers and singers. The ratio of dancers to singers is 3:2. There are 30 performers total, how many of each are there?

To solve, notice that 3:2 is a reduced ratio, so there is a number, n , that we can multiply both by to find the total number in each group. Represent dancers and singers as expressions in terms of n . Then set up and solve an equation.

$$\begin{aligned} \text{dancers} = 3n, \text{ singers} = 2n &\longrightarrow 3n + 2n = 30 \\ 5n &= 30 \\ n &= 6 \end{aligned}$$

There are $3 \cdot 6 = 18$ dancers and $2 \cdot 6 = 12$ singers.

Watch this video for help with the Examples above.



MEDIA

Click image to the left for more content.

[CK-12 Foundation: Chapter7FormsofRatiosB](#)

Concept Problem Revisited

Everything needs to be scaled down by a factor of $\frac{1}{18}$ ($144 \text{ in} \div 8 \text{ in}$). Change everything into inches and then multiply by the scale factor.

Bed: 36 in by 75 in \rightarrow 2 in by 4.167 in

Desk: 48 in by 24 in \rightarrow 2.67 in by 1.33 in

Chair: 36 in by 36 in \rightarrow 2 in by 2 in

There are several layout options for these three pieces of furniture. Draw an 8 in by 8 in square and then the appropriate rectangles for the furniture. Then, cut out the rectangles and place inside the square.

Vocabulary

A *ratio* is a way to compare two numbers. Ratios can be written in three ways: $\frac{a}{b}$, $a : b$, and a to b .

Guided Practice

The total bagel sales at a bagel shop for Monday is in the table below.

TABLE 7.1:

| <i>Type of Bagel</i> | <i>Number Sold</i> |
|----------------------|--------------------|
| Plain | 80 |
| Cinnamon Raisin | 30 |
| Sesame | 25 |
| Jalapeno Cheddar | 20 |
| Everything | 45 |
| Honey Wheat | 50 |

1. What is the ratio of cinnamon raisin bagels to plain bagels?
2. What is the ratio of honey wheat bagels to total bagels sold?
3. What is the ratio of cinnamon raisin bagels to sesame bagels to jalapeno cheddar bagels?

Answers:

1. The ratio is 30:80. Reducing the ratio by 10, we get 3:8.
2. Order matters. Honey wheat is listed first, so that number comes first in the ratio (or on the top of the fraction). Find the total number of bagels sold, $80 + 30 + 25 + 20 + 45 + 50 = 250$.

The ratio is $\frac{50}{250} = \frac{1}{5}$.

3. You can have ratios that compare more than two numbers and they work just the same way. The ratio for this problem is 30:25:20, which reduces to 6:5:4.

Practice

1. The votes for president in a club election were: Smith : 24 Munoz : 32 Park : 20 Find the following ratios and write in simplest form.
 - a. Votes for Munoz to Smith
 - b. Votes for Park to Munoz
 - c. Votes for Smith to total votes
 - d. Votes for Smith to Munoz to Park

Use the picture to write the following ratios for questions 2-6.

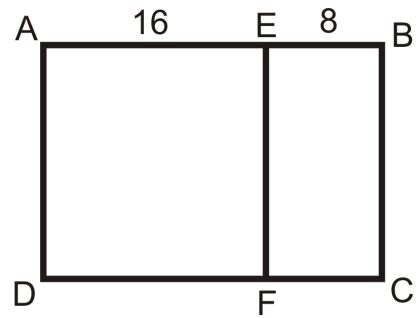

$AEFD$ is a square

$ABCD$ is a rectangle

2. $AE : EF$
3. $EB : AB$
4. $DF : FC$
5. $EF : BC$
6. Perimeter $ABCD$: Perimeter $AEFD$: Perimeter $EBCF$
7. The measures of the angles of a triangle are have the ratio 3:3:4. What are the measures of the angles?
8. The lengths of the sides in a triangle are in a 3:4:5 ratio. The perimeter of the triangle is 36. What are the lengths of the sides?
9. The length and width of a rectangle are in a 3:5 ratio. The perimeter of the rectangle is 64. What are the length and width?
10. The length and width of a rectangle are in a 4:7 ratio. The perimeter of the rectangle is 352. What are the length and width?
11. The ratio of the short side to the long side in a parallelogram is 5:9. The perimeter of the parallelogram is 112. What are the lengths of the sides?
12. The length and width of a rectangle are in a 3:11 ratio. The area of the rectangle is 528. What are the length and width of the rectangle?
13. The length and width of a rectangle are in a 2:15 ratio. The area of the rectangle is 3630. What are the length and width of the rectangle?
14. Two squares have areas of 4cm^2 and 16cm^2 . What is the ratio of the side length of the smaller square to the side length of the larger square?
15. Two triangles are congruent. What is the ratio between their side lengths?

7.2 Proportion Properties

Here you'll learn how to set up and solve proportions.

What if you were told that a scale model of a python is in the ratio of 1:24? If the model measures 0.75 feet long, how long is the real python? After completing this Concept, you'll be able to solve problems like this one by using a proportion.



Watch This



MEDIA

Click image to the left for more content.

CK-12 Foundation: Chapter7ProportionPropertiesA

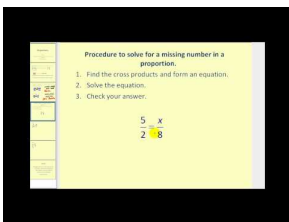

MEDIA

Click image to the left for more content.

James Sousa:Proportions

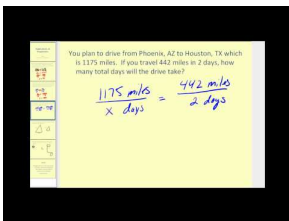

MEDIA

Click image to the left for more content.

James Sousa: Applications of Proportions

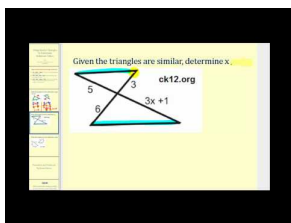

MEDIA

Click image to the left for more content.

James Sousa: Using Similar Triangles to Determine Unknown Values

Guidance

A **proportion** is when two ratios are set equal to each other.

Cross-Multiplication Theorem: Let $a, b, c,$ and d be real numbers, with $b \neq 0$ and $d \neq 0$. If $\frac{a}{b} = \frac{c}{d}$, then $ad = bc$.

The proof of the Cross-Multiplication Theorem is an algebraic proof. Recall that multiplying by $\frac{2}{2}$, $\frac{b}{b}$, or $\frac{d}{d} = 1$ because it is the same number divided by itself ($b \div b = 1$).

Proof of the Cross-Multiplication Theorem:

$$\begin{aligned} \frac{a}{b} &= \frac{c}{d} && \text{Multiply the left side by } \frac{d}{d} \text{ and the right side by } \frac{b}{b}. \\ \frac{a}{b} \cdot \frac{d}{d} &= \frac{c}{d} \cdot \frac{b}{b} \\ \frac{ad}{bd} &= \frac{bc}{bd} && \text{The denominators are the same, so the numerators are equal.} \\ ad &= bc \end{aligned}$$

Think of the Cross-Multiplication Theorem as a shortcut. Without this theorem, you would have to go through all of these steps every time to solve a proportion. The Cross-Multiplication Theorem has several sub-theorems that follow from its proof. The formal term is **corollary**.

Corollary #1: If $a, b, c,$ and d are nonzero and $\frac{a}{b} = \frac{c}{d}$, then $\frac{a}{c} = \frac{b}{d}$.

Corollary #2: If $a, b, c,$ and d are nonzero and $\frac{a}{b} = \frac{c}{d}$, then $\frac{d}{b} = \frac{c}{a}$.

Corollary #3: If $a, b, c,$ and d are nonzero and $\frac{a}{b} = \frac{c}{d}$, then $\frac{b}{a} = \frac{d}{c}$.

Corollary #4: If $a, b, c,$ and d are nonzero and $\frac{a}{b} = \frac{c}{d}$, then $\frac{a+b}{b} = \frac{c+d}{d}$.

Corollary #5: If $a, b, c,$ and d are nonzero and $\frac{a}{b} = \frac{c}{d}$, then $\frac{a-b}{b} = \frac{c-d}{d}$.

Example A

Solve the proportions.

a) $\frac{4}{5} = \frac{x}{30}$

b) $\frac{y+1}{8} = \frac{5}{20}$

c) $\frac{6}{5} = \frac{2x+4}{x-2}$

To solve a proportion, you need to **cross-multiply**.

a)

$$\frac{4}{5} = \frac{x}{30}$$

$$4 \cdot 30 = 5 \cdot x$$

$$120 = 5x$$

$$24 = x$$

b)

$$\frac{y+1}{8} = \frac{5}{20}$$

$$(y+1) \cdot 20 = 5 \cdot 8$$

$$20y + 20 = 40$$

$$20y = 20$$

$$y = 1$$

c)

$$\frac{6}{5} = \frac{2x+4}{x-2}$$

$$6 \cdot (x-2) = 5 \cdot (2x+4)$$

$$6x-12 = 10x+20$$

$$-32 = 4x$$

$$-8 = x$$

Example B

Your parents have an architect's drawing of their home. On the paper, the house's dimensions are 36 in by 30 in. If the shorter length of your parents' house is actually 50 feet, what is the longer length?

Set up a proportion. If the shorter length is 50 feet, then it will line up with 30 in. It does not matter which numbers you put in the numerators of the fractions, as long as they line up correctly.

$$\frac{30}{36} = \frac{50}{x} \rightarrow 1800 = 30x$$

$$60 = x$$

So, the dimension of your parents' house is 50 ft by 60 ft.

Example C

Suppose we have the proportion $\frac{2}{5} = \frac{14}{35}$. Write down the other three true proportions that follow from this one.

First of all, we know this is a true proportion because you would multiply $\frac{2}{5}$ by $\frac{7}{7}$ to get $\frac{14}{35}$. Using the three corollaries, we would get:

1. $\frac{2}{14} = \frac{5}{35}$
2. $\frac{35}{5} = \frac{14}{2}$
3. $\frac{5}{2} = \frac{35}{14}$

If you cross-multiply all four of these proportions, you would get $70 = 70$ for each one.

Watch this video for help with the Examples above.



MEDIA

Click image to the left for more content.

[CK-12 Foundation: Chapter7ProportionPropertiesB](#)

Concept Problem Revisited

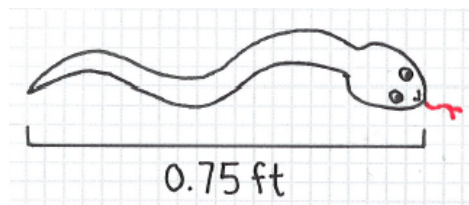

The scale model of a python is 0.75 ft long and in the ratio 1:24. If x is the length of the real python in ft:

$$\frac{1}{24} = \frac{0.75}{x} \rightarrow x = 24(0.75)$$

$$x = 18$$

The real python is 18 ft long.

Vocabulary

A **ratio** is a way to compare two numbers. Ratios can be written in three ways: $\frac{a}{b}$, $a : b$, and a to b . A **proportion** is two ratios that are set equal to each other. To solve a proportion you should **cross-multiply**, which means to set the product of the numerator of the first fraction and the denominator of the second fraction equal to the product of the denominator of the first fraction and the numerator of the second fraction. A **corollary** is a theorem that follows directly from another theorem.

Guided Practice

1. In the picture, $\frac{AB}{XY} = \frac{BC}{YZ} = \frac{AC}{XZ}$.

Find the measures of AC and XY .

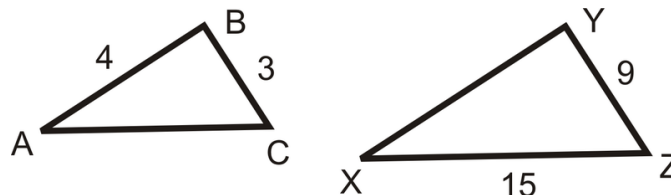

2. In the picture, $\frac{ED}{AD} = \frac{BC}{AC}$. Find y .

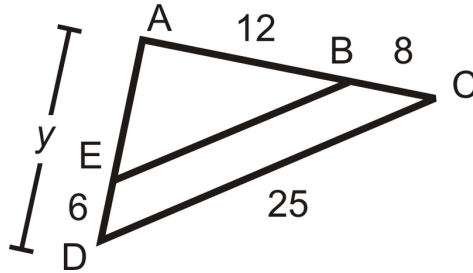

3. If $\frac{AB}{BE} = \frac{AC}{CD}$ in the picture above, find BE .

Answers:

1. This is an example of an *extended* proportion. Substituting in the numbers for the sides we know, we have $\frac{4}{XY} = \frac{3}{9} = \frac{AC}{15}$. Separate this into two different proportions and solve for XY and AC .

$$\begin{aligned} \frac{4}{XY} &= \frac{3}{9} & \frac{3}{9} &= \frac{AC}{15} \\ 36 &= 3(XY) & 9(AC) &= 45 \\ XY &= 12 & AC &= 5 \end{aligned}$$

2. Substituting in the numbers for the sides we know, we have

$$\begin{aligned} \frac{6}{y} &= \frac{8}{12+8} \rightarrow 8y = 6(20) \\ y &= 15 \end{aligned}$$

3.

$$\begin{aligned} \frac{12}{BE} &= \frac{20}{25} \rightarrow 20(BE) = 12(25) \\ BE &= 15 \end{aligned}$$

Practice

Solve each proportion.

1. $\frac{x}{10} = \frac{42}{35}$

2. $\frac{x}{x-2} = \frac{5}{7}$

3. $\frac{6}{9} = \frac{y}{24}$

4. $\frac{x}{9} = \frac{16}{x}$

5. $\frac{y-3}{8} = \frac{y+6}{5}$

6. $\frac{20}{z+5} = \frac{16}{7}$

7. Shawna drove 245 miles and used 8.2 gallons of gas. At the same rate, if she drove 416 miles, how many gallons of gas will she need? Round to the nearest tenth.

8. The president, vice-president, and financial officer of a company divide the profits in a 4:3:2 ratio. If the company made \$1,800,000 last year, how much did each person receive?

9. Many recipes describe ratios between ingredients. For example, one recipe for paper mache paste suggests 3 parts flour to 5 parts water. If we have one cup of flour, how much water should we add to make the paste?
10. A recipe for krispy rice treats calls for 6 cups of rice cereal and 40 large marshmallows. You want to make a larger batch of goodies and have 9 cups of rice cereal. How many large marshmallows do you need? However, you only have the miniature marshmallows at your house. You find a list of substitution quantities on the internet that suggests 10 large marshmallows are equivalent to 1 cup miniatures. How many cups of miniatures do you need?

Given the true proportion, $\frac{10}{6} = \frac{15}{d} = \frac{x}{y}$ and $d, x,$ and y are nonzero, determine if the following proportions are also true.

11. $\frac{10}{y} = \frac{x}{6}$
12. $\frac{15}{10} = \frac{d}{6}$
13. $\frac{6+10}{10} = \frac{y+x}{x}$
14. $\frac{15}{x} = \frac{y}{d}$

For questions 15-18, $\frac{AE}{ED} = \frac{BC}{CD}$ and $\frac{ED}{AD} = \frac{CD}{DB} = \frac{EC}{AB}$.

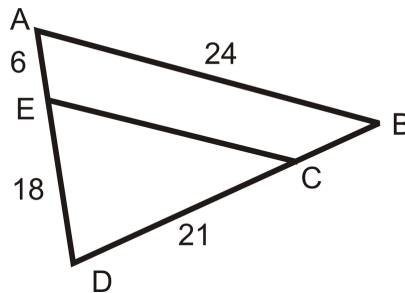

15. Find DB .
 16. Find EC .
 17. Find CB .
 18. Find AD .
19. **Writing** Explain why $\frac{a+b}{b} = \frac{c+d}{d}$ is a valid proportion. HINT: Cross-multiply and see if it equals $ad = bc$.
 20. **Writing** Explain why $\frac{a-b}{b} = \frac{c-d}{d}$ is a valid proportion. HINT: Cross-multiply and see if it equals $ad = bc$.

7.3 Similar Polygons and Scale Factors

Here you'll learn how to identify similar polygons and how to use scale factors to solve for missing sides of similar polygons.

What if you were comparing a baseball diamond and a softball diamond? A baseball diamond is a square with 90 foot sides. A softball diamond is a square with 60 foot sides. Are the two diamonds similar? If so, what is the scale factor? After completing this Concept, you'll be able to use your knowledge of similar polygons to answer these questions.

Watch This



MEDIA

Click image to the left for more content.

[CK-12 Foundation: Chapter7SimilarPolygonsandScaleFactorsA](#)

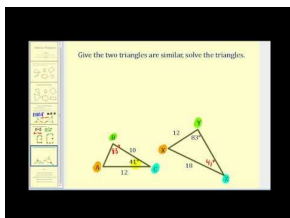

MEDIA

Click image to the left for more content.

[James Sousa:SimilarPolygons](#)

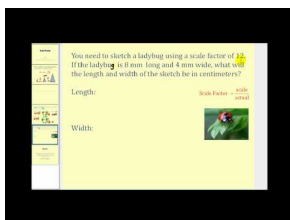

MEDIA

Click image to the left for more content.

[James Sousa:Scale Factor](#)

Guidance

Similar polygons are two polygons with the same shape, but not necessarily the same size. Similar polygons have corresponding angles that are **congruent**, and corresponding sides that are **proportional**.

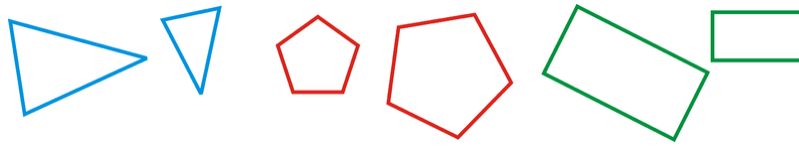

These polygons are not similar:

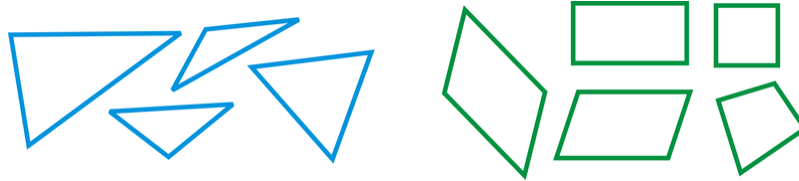

Think about similar polygons as enlarging or shrinking the same shape. The symbol \sim is used to represent similarity. Specific types of triangles, quadrilaterals, and polygons will always be similar. For example, ***all equilateral triangles are similar*** and ***all squares are similar***. If two polygons are similar, we know the lengths of corresponding sides are proportional. In similar polygons, the ratio of one side of a polygon to the corresponding side of the other is called the **scale factor**. The ratio of all parts of a polygon (including the perimeters, diagonals, medians, midsegments, altitudes) is the same as the ratio of the sides.

Example A

Suppose $\triangle ABC \sim \triangle JKL$. Based on the similarity statement, which angles are congruent and which sides are proportional?

Just like in a congruence statement, the congruent angles line up within the similarity statement. So, $\angle A \cong \angle J$, $\angle B \cong \angle K$, and $\angle C \cong \angle L$. Write the sides in a proportion: $\frac{AB}{JK} = \frac{BC}{KL} = \frac{AC}{JL}$. Note that the proportion could be written in different ways. For example, $\frac{AB}{BC} = \frac{JK}{KL}$ is also true.

Example B

$MNPQ \sim RSTU$. What are the values of x , y and z ?

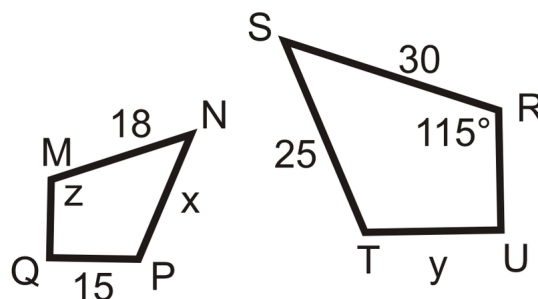

In the similarity statement, $\angle M \cong \angle R$, so $z = 115^\circ$. For x and y , set up proportions.

$$\begin{aligned}\frac{18}{30} &= \frac{x}{25} \\ 450 &= 30x \\ x &= 15\end{aligned}$$

$$\begin{aligned}\frac{18}{30} &= \frac{15}{y} \\ 18y &= 450 \\ y &= 25\end{aligned}$$

Example C

$ABCD \sim AMNP$. Find the scale factor and the length of BC .

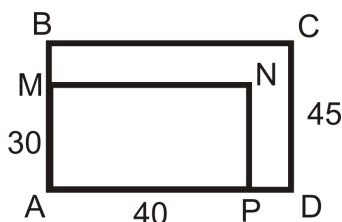

Line up the corresponding sides, AB and $AM = CD$, so the scale factor is $\frac{30}{45} = \frac{2}{3}$ or $\frac{3}{2}$. Because BC is in the bigger rectangle, we will multiply 40 by $\frac{3}{2}$ because $\frac{3}{2}$ is greater than 1. $BC = \frac{3}{2}(40) = 60$.

Watch this video for help with the Examples above.

**MEDIA**

Click image to the left for more content.

[CK-12 Foundation: Chapter7SimilarPolygonsandScaleFactorsB](#)

Concept Problem Revisited

All of the sides in the baseball diamond are 90 feet long and 60 feet long in the softball diamond. This means all the sides are in a $\frac{90}{60} = \frac{3}{2}$ ratio. All the angles in a square are congruent, all the angles in both diamonds are congruent. The two squares are similar and the scale factor is $\frac{3}{2}$.

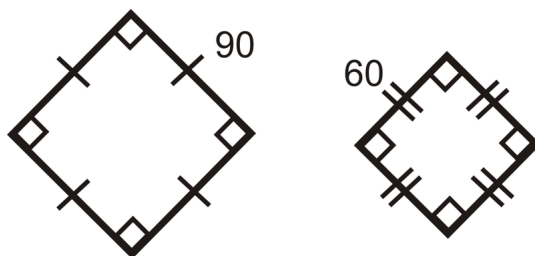
**Vocabulary**

Similar polygons are two polygons with the same shape, but not necessarily the same size. The corresponding angles of similar polygons are **congruent** (exactly the same) and the corresponding sides are **proportional** (in the same ratio). In similar polygons, the ratio of one side of a polygon to the corresponding side of the other is called the **scale factor**.

Guided Practice

1. $ABCD$ and $UVWX$ are below. Are these two rectangles similar?

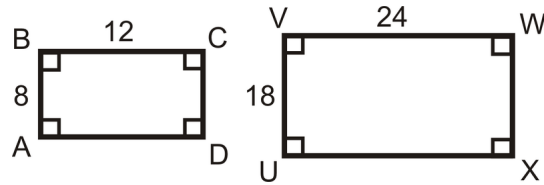

2. What is the scale factor of $\triangle ABC$ to $\triangle XYZ$? Write the similarity statement.

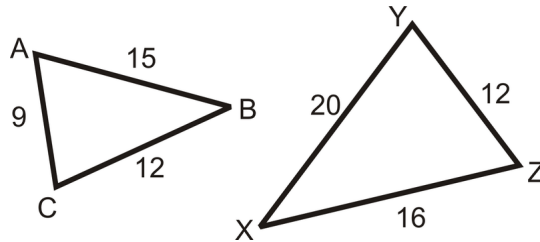

3. $\triangle ABC \sim \triangle MNP$. The perimeter of $\triangle ABC$ is 150, $AB = 32$ and $MN = 48$. Find the perimeter of $\triangle MNP$.

Answers:

1. All the corresponding angles are congruent because the shapes are rectangles.

Let's see if the sides are proportional. $\frac{8}{12} = \frac{2}{3}$ and $\frac{18}{24} = \frac{3}{4}$. $\frac{2}{3} \neq \frac{3}{4}$, so the sides are **not** in the same proportion, and the rectangles are **not** similar.

2. All the sides are in the same ratio. Pick the two largest (or smallest) sides to find the ratio.

$$\frac{15}{20} = \frac{3}{4}$$

For the similarity statement, line up the proportional sides. $AB \rightarrow XY, BC \rightarrow XZ, AC \rightarrow YZ$, so $\triangle ABC \sim \triangle YXZ$.

3. From the similarity statement, AB and MN are corresponding sides. The scale factor is $\frac{32}{48} = \frac{2}{3}$ or $\frac{3}{2}$. $\triangle ABC$ is the smaller triangle, so the perimeter of $\triangle MNP$ is $\frac{3}{2}(150) = 225$.

Practice

Determine if the following statements are true or false.

- All equilateral triangles are similar.
- All isosceles triangles are similar.
- All rectangles are similar.
- All rhombuses are similar.
- All squares are similar.
- All congruent polygons are similar.
- All similar polygons are congruent.
- All regular pentagons are similar.
- $\triangle BIG \sim \triangle HAT$. List the congruent angles and proportions for the sides.
- If $BI = 9$ and $HA = 15$, find the scale factor.
- If $BG = 21$, find HT .
- If $AT = 45$, find IG .
- Find the perimeter of $\triangle BIG$ and $\triangle HAT$. What is the ratio of the perimeters?

Use the picture to the right to answer questions 14-18.

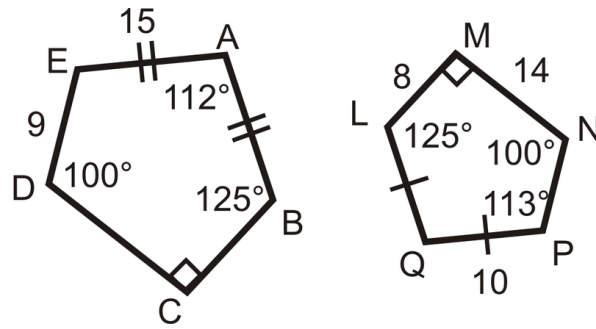

14. Find $m\angle E$ and $m\angle Q$.
15. $ABCDE \sim QLMNP$, find the scale factor.
16. Find BC .
17. Find CD .
18. Find NP .

Determine if the following triangles and quadrilaterals are similar. If they are, write the similarity statement.

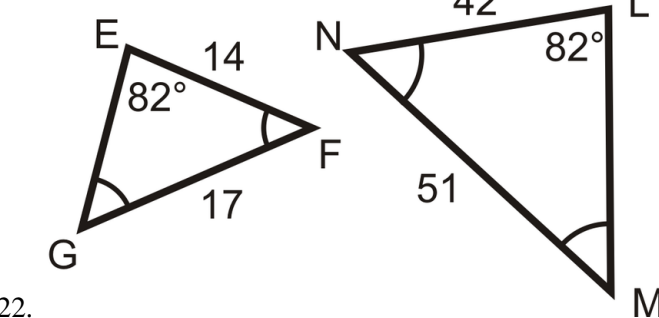
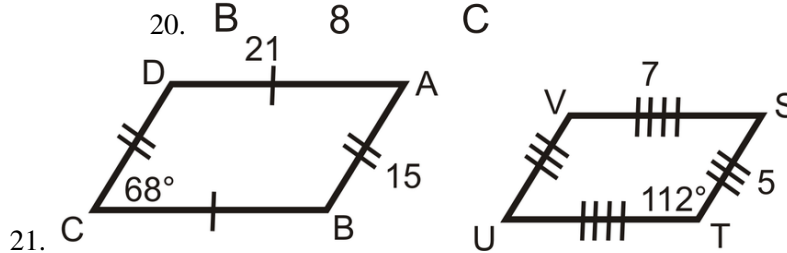
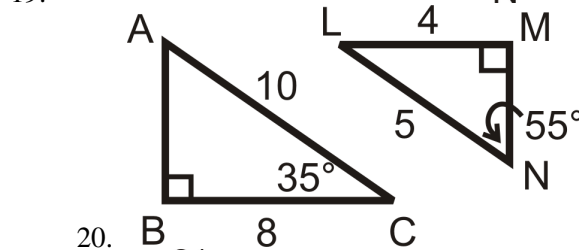
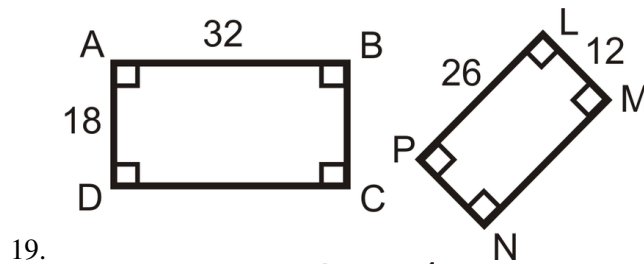

23. $\triangle ABC \sim \triangle DEF$ Solve for x and y .

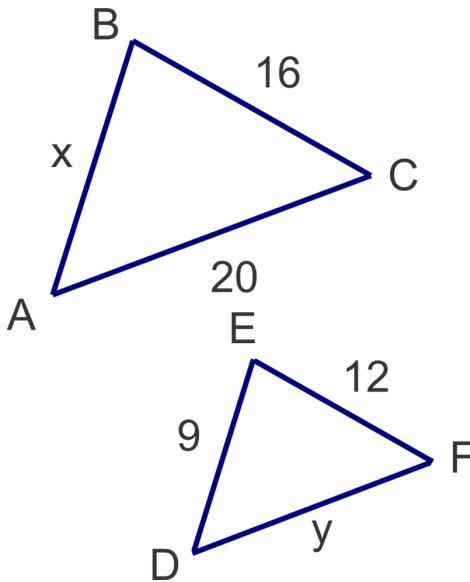

24. $QUAD \sim KENT$ Find the perimeter of $QUAD$.

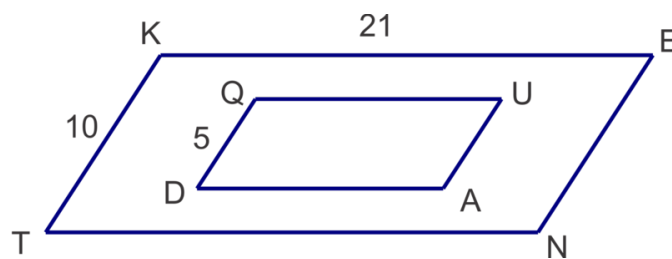

25. $\triangle CAT \sim \triangle DOG$ Solve for x and y .

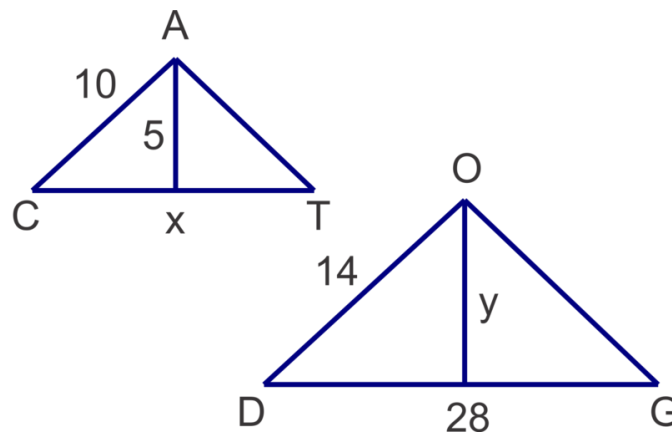

26. $PENTA \sim FIVER$ Solve for x .

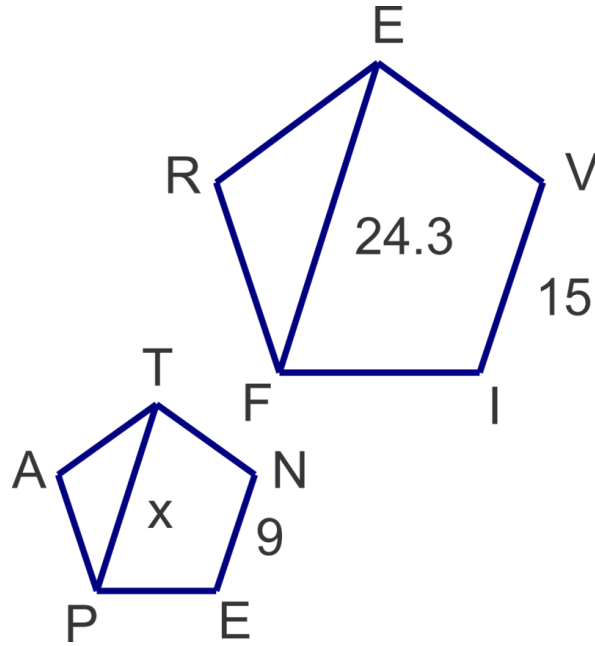

27. $\triangle MNO \sim \triangle XNY$ Solve for a and b .

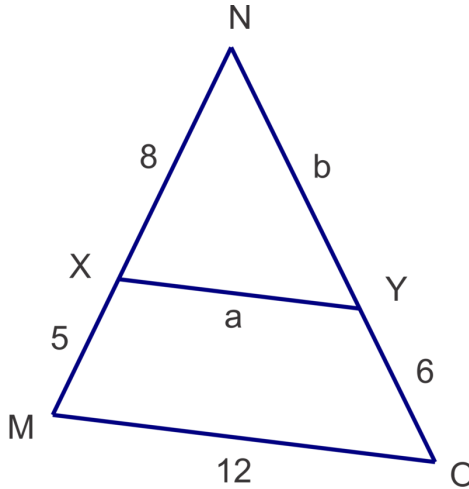

28. Trapezoids $HAVE \sim KNOT$ Solve for x and y .

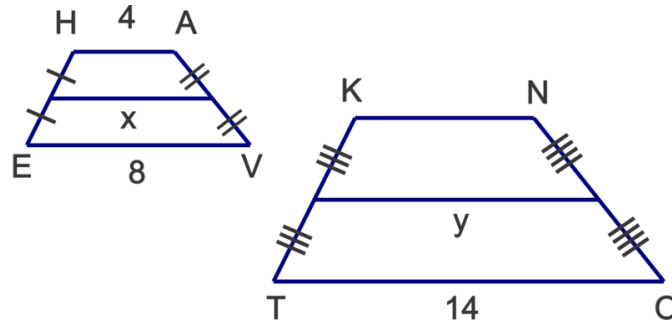

29. Two similar octagons have a scale factor of $\frac{9}{11}$. If the perimeter of the smaller octagon is 99 meters, what is the perimeter of the larger octagon?
30. Two right triangles are similar. The legs of one of the triangles are 5 and 12. The second right triangle has a hypotenuse of length 39. What is the scale factor between the two triangles?
31. What is the area of the smaller triangle in problem 30? What is the area of the larger triangle in problem 30? What is the ratio of the areas? How does it compare to the ratio of the lengths (or scale factor)? Recall that the area of a triangle is $A = \frac{1}{2}bh$.

7.4 AA Similarity

Here you'll learn how to determine whether or not two triangles are similar using AA Similarity.

What if you were given a pair of triangles and the angle measures for two of their angles? How could you use this information to determine if the two triangles are similar? After completing this Concept, you'll be able to use AA Similarity to decide if two triangles are similar.

Watch This



MEDIA

Click image to the left for more content.

[CK-12 Foundation: Chapter7AASimilarityA](#)

Watch this video beginning at the 2:09 mark.

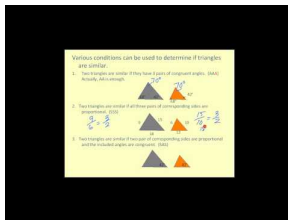

MEDIA

Click image to the left for more content.

[James Sousa:SimilarTriangles](#)

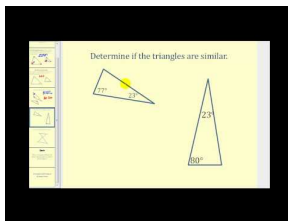

MEDIA

Click image to the left for more content.

[James Sousa:SimilarTriangles by AA](#)

Guidance

The Third Angle Theorem states if two angles are congruent to two angles in another triangle, the third angles are congruent too. Because a triangle has 180° , the third angle in any triangle is 180° minus the other two angle measures. Let's investigate what happens when two different triangles have the same angle measures.

Investigation: Constructing Similar Triangles

Tools Needed: pencil, paper, protractor, ruler

1. Draw a 45° angle. Extend the horizontal side and then draw a 60° angle on the other side of this side. Extend the other side of the 45° angle and the 60° angle so that they intersect to form a triangle. What is the measure of the third angle? Measure the length of each side.

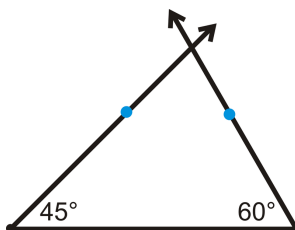

2. Repeat Step 1 and make the horizontal side between the 45° and 60° angle at least 1 inch longer than in Step 1. This will make the entire triangle larger. Find the measure of the third angle and measure the length of each side.

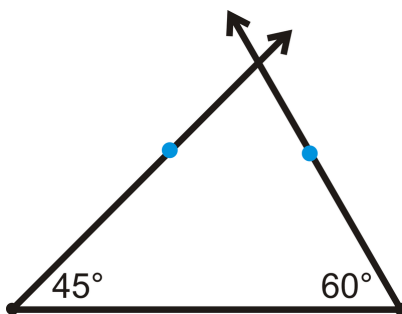

3. Find the ratio of the sides. Put the sides opposite the 45° angles over each other, the sides opposite the 60° angles over each other, and the sides opposite the third angles over each other. What happens?

AA Similarity Postulate: If two angles in one triangle are congruent to two angles in another triangle, the two triangles are similar.

The AA Similarity Postulate is a shortcut for showing that two *triangles* are similar. If you know that two angles in one triangle are congruent to two angles in another, which is now enough information to show that the two triangles are similar. Then, you can use the similarity to find the lengths of the sides.

Example A

Determine if the following two triangles are similar. If so, write the similarity statement.

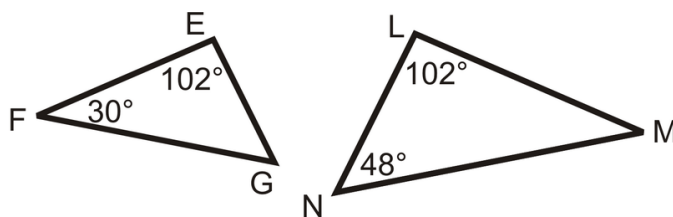

Find the measure of the third angle in each triangle. $m\angle G = 48^\circ$ and $m\angle M = 30^\circ$ by the Triangle Sum Theorem. Therefore, all three angles are congruent, so the two triangles are similar. $\triangle FEG \sim \triangle MLN$.

Example B

Determine if the following two triangles are similar. If so, write the similarity statement.

$m\angle C = 39^\circ$ and $m\angle F = 59^\circ$. The angles are not equal, $\triangle ABC$ and $\triangle DEF$ are not similar.

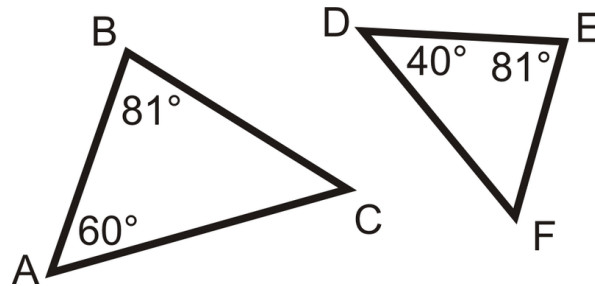
**Example C**

Are the following triangles similar? If so, write the similarity statement.

Because $\overline{AE} \parallel \overline{CD}$, $\angle A \cong \angle D$ and $\angle C \cong \angle E$ by the Alternate Interior Angles Theorem. Therefore, by the AA Similarity Postulate, $\triangle ABE \sim \triangle DBC$.

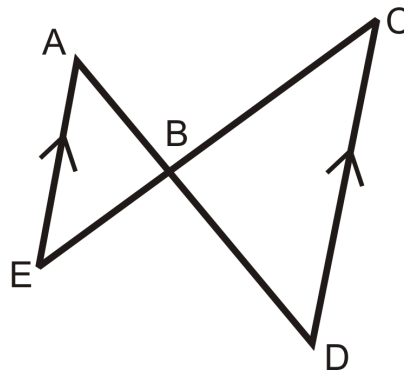

Watch this video for help with the Examples above.



MEDIA

Click image to the left for more content.

[CK-12 Foundation: Chapter7AASimilarityB](#)

Vocabulary

Two triangles are **similar** if all their corresponding angles are **congruent** (exactly the same) and their corresponding sides are **proportional** (in the same ratio).

Guided Practice

Are the following triangles similar? If so, write a similarity statement.

1.

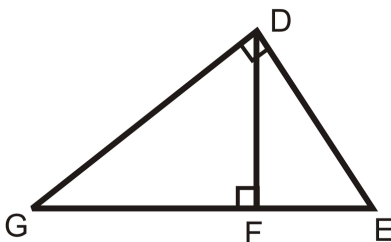

2.

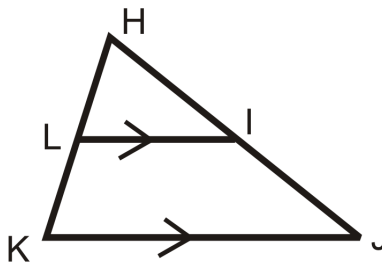

3.

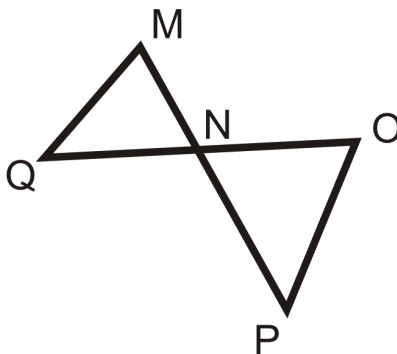

Answers:

1. Yes, $\triangle DGE \sim \triangle FGD \sim \triangle FDE$.

2. Yes, $\triangle HLI \sim \triangle HMJ$.

3. No, though $\angle MNQ \cong \angle ONP$ because they are vertical angles, we need to have two pairs of congruent angles in order to be able to say that the triangles are similar.

Practice

Use the diagram to complete each statement.

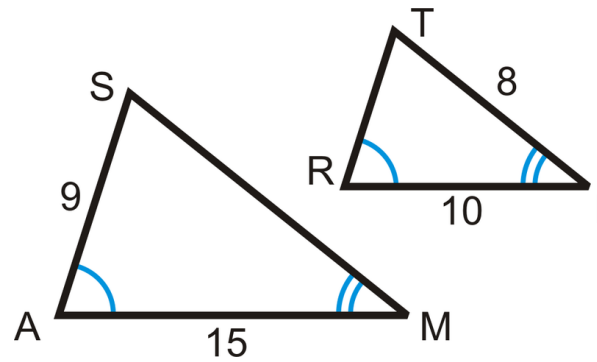

1. $\triangle SAM \sim \triangle$ _____
2. $\frac{SA}{?} = \frac{SM}{?} = \frac{?}{RI}$
3. $SM =$ _____
4. $TR =$ _____
5. $\frac{9}{?} = \frac{?}{8}$

Answer questions 6-9 about trapezoid $ABCD$.

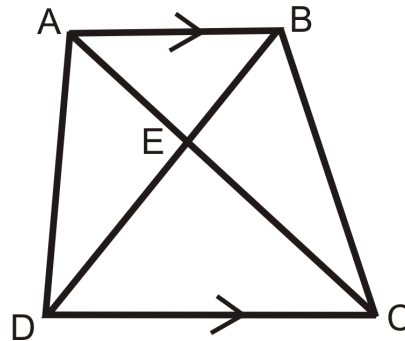

6. Name two similar triangles. How do you know they are similar?
7. Write a true proportion.
8. Name two other triangles that might *not* be similar.
9. If $AB = 10$, $AE = 7$, and $DC = 22$, find AC . Be careful!
10. **Writing** How many angles need to be congruent to show that two triangles are similar? Why?
11. **Writing** How do congruent triangles and similar triangles differ? How are they the same?

Use the triangles below for questions 12-15.

$AB = 20$, $DE = 15$, and $BC = k$.

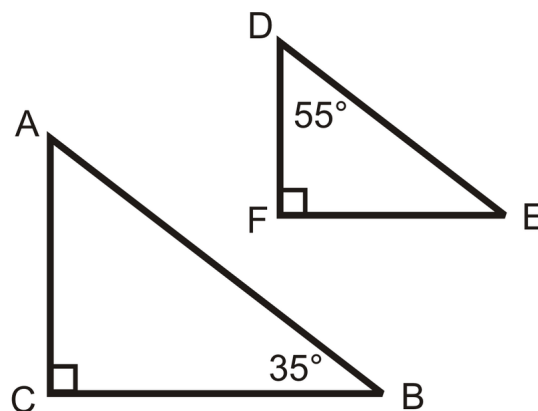

12. Are the two triangles similar? How do you know?
13. Write an expression for FE in terms of k .
14. If $FE = 12$, what is k ?
15. Fill in the blanks: If an acute angle of a _____ triangle is congruent to an acute angle in another _____-triangle, then the two triangles are _____.

Use the diagram below to answer questions 16-20.

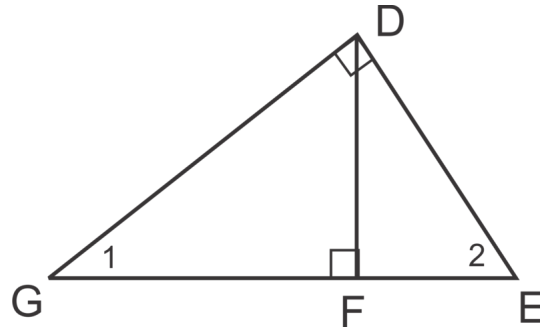

16. Draw the three separate triangles in the diagram.
17. Explain why $\triangle GDE \sim \triangle DFE \sim \triangle GFD$.

Complete the following proportionality statements.

18. $\frac{GF}{DF} = \frac{?}{FE}$
19. $\frac{GF}{GD} = \frac{?}{GE}$
20. $\frac{GE}{DE} = \frac{DE}{?}$

7.5 Indirect Measurement

Here you'll learn how to apply your knowledge of similar triangles and proportions to model real-life situations and to find unknown measurements indirectly.

What if you wanted to measure the height of a flagpole using your friend George? He is 6 feet tall and his shadow is 10 feet long. At the same time, the shadow of the flagpole was 85 feet long. How tall is the flagpole? After completing this Concept, you'll be able to use indirect measurement to help you answer this question.

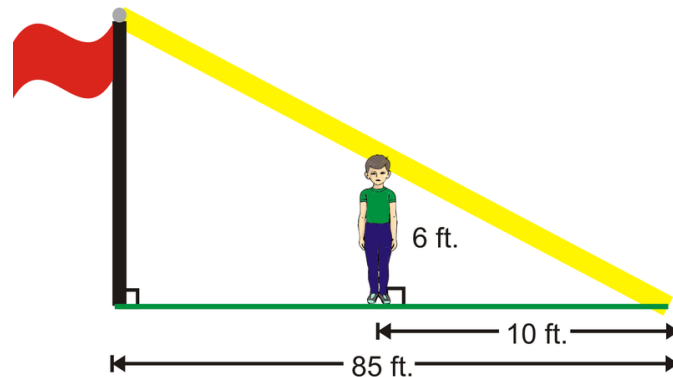

Watch This



MEDIA

Click image to the left for more content.

CK-12 Foundation: Chapter7IndirectMeasurementA

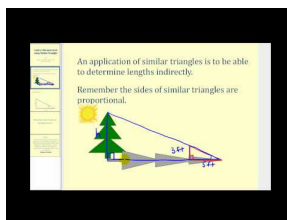

MEDIA

Click image to the left for more content.

James Sousa:Indirect MeasurementUsing Similar Triangles

Guidance

An application of similar triangles is to measure lengths *indirectly*. The length to be measured would be some feature that was not easily accessible to a person, such as the width of a river or canyon and the height of a tall object. To measure something indirectly, you need to set up a pair of similar triangles.

Example A

A tree outside Ellie's building casts a 125 foot shadow. At the same time of day, Ellie casts a 5.5 foot shadow. If Ellie is 4 feet 10 inches tall, how tall is the tree?

Draw a picture. From the picture to the right, we see that the tree and Ellie are parallel, therefore the two triangles are similar to each other. Write a proportion.

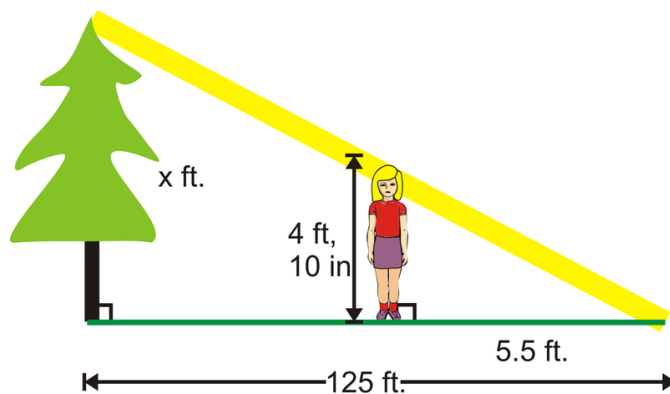

$$\frac{4\text{ft}, 10\text{in}}{x\text{ft}} = \frac{5.5\text{ft}}{125\text{ft}}$$

Notice that our measurements are not all in the same units. Change both numerators to inches and then we can cross multiply.

$$\begin{aligned} \frac{58\text{in}}{x\text{ft}} &= \frac{66\text{in}}{125\text{ft}} \rightarrow 58(125) = 66(x) \\ 7250 &= 66x \\ x &\approx 109.85\text{ft} \end{aligned}$$

Example B

Cameron is 5 ft tall and casts a 12 ft shadow. At the same time of day, a nearby building casts a 78 ft shadow. How tall is the building?

To solve, set up a proportion that compares height to shadow length for Cameron and the building. Then solve the equation to find the height of the building. Let x represent the height of the building.

$$\begin{aligned} \frac{5\text{ft}}{12\text{ft}} &= \frac{x}{78\text{ft}} \\ 12x &= 390 \\ x &= 32.5\text{ft} \end{aligned}$$

The building is 32.5 feet tall.

Example C

The Empire State Building is 1250 ft. tall. At 3:00, Pablo stands next to the building and has an 8 ft. shadow. If he is 6 ft tall, how long is the Empire State Building's shadow at 3:00?

Similar to Example B, solve by setting up a proportion that compares height to shadow length. Then solve the equation to find the length of the shadow. Let x represent the length of the shadow.

$$\begin{aligned}\frac{6ft}{8ft} &= \frac{1250ft}{x} \\ 6x &= 10000 \\ x &= 1666.67ft\end{aligned}$$

The shadow is approximately 1666.67 feet long.

Watch this video for help with the Examples above.

**MEDIA**

Click image to the left for more content.

[CK-12 Foundation: Chapter7IndirectMeasurementB](#)

Concept Problem Revisited

It is safe to assume that George and the flagpole stand vertically, making right angles with the ground. Also, the angle where the sun's rays hit the ground is the same for both. The two triangles are similar. Set up a proportion.

$$\begin{aligned}\frac{10}{85} &= \frac{6}{x} \longrightarrow 10x = 510 \\ x &= 51 \text{ ft.}\end{aligned}$$

The height of the flagpole is 51 feet.

Vocabulary

Two triangles are *similar* if all their corresponding angles are *congruent* (exactly the same) and their corresponding sides are *proportional* (in the same ratio). Solve proportions by *cross-multiplying*.

Guided Practice

In order to estimate the width of a river, the following technique can be used. Use the diagram.

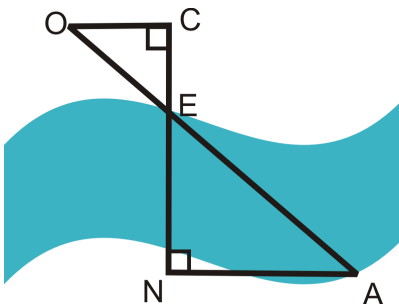

Place three markers, O, C , and E on the upper bank of the river. E is on the edge of the river and $\overline{OC} \perp \overline{CE}$. Go across the river and place a marker, N so that it is collinear with C and E . Then, walk along the lower bank of the river and place marker A , so that $\overline{CN} \perp \overline{NA}$. $OC = 50$ feet, $CE = 30$ feet, $NA = 80$ feet.

1. Is $\triangle OCE \sim \triangle ANE$? How do you know?
2. Is $\overline{OC} \parallel \overline{NA}$? How do you know?
3. What is the width of the river? Find EN .

Answers:

1. Yes. $\angle C \cong \angle N$ because they are both right angles. $\angle OEC \cong \angle AEN$ because they are vertical angles. This means $\triangle OCE \sim \triangle ANE$ by the AA Similarity Postulate.
2. Since the two triangles are similar, we must have $\angle EOC \cong \angle EAN$. These are alternate interior angles. When alternate interior angles are congruent then lines are parallel, so $\overline{OC} \parallel \overline{NA}$.
3. Set up a proportion and solve by cross-multiplying.

$$\frac{30\text{ft}}{EN} = \frac{50\text{ft}}{80\text{ft}}$$

$$50(EN) = 2400$$

$$EN = 48$$

The river is 48 feet wide.

Practice

The technique from the guided practice section was used to measure the distance across the Grand Canyon. Use the picture below and $OC = 72$ ft, $CE = 65$ ft, and $NA = 14,400$ ft for problems 1 - 3.

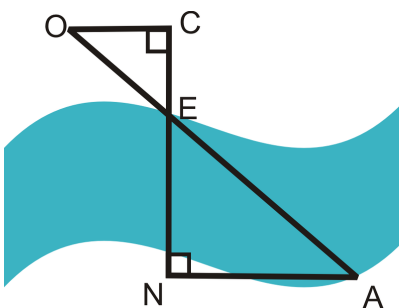

1. Find EN (the distance across the Grand Canyon).
2. Find OE .

3. Find EA .
4. Janet wants to measure the height of her apartment building. She places a pocket mirror on the ground 20 ft from the building and steps backwards until she can see the top of the build in the mirror. She is 18 in from the mirror and her eyes are 5 ft 3 in above the ground. The angle formed by her line of sight and the ground is congruent to the angle formed by the reflection of the building and the ground. You may wish to draw a diagram to illustrate this problem. How tall is the building?
5. Sebastian is curious to know how tall the announcer's box is on his school's football field. On a sunny day he measures the shadow of the box to be 45 ft and his own shadow is 9 ft. Sebastian is 5 ft 10 in tall. Find the height of the box.
6. Juanita wonders how tall the mast of a ship she spots in the harbor is. The deck of the ship is the same height as the pier on which she is standing. The shadow of the mast is on the pier and she measures it to be 18 ft long. Juanita is 5 ft 4 in tall and her shadow is 4 ft long. How tall is the ship's mast?
7. Evan is 6 ft tall and casts a 15 ft shadow. At the same time of day, a nearby building casts a 30 ft shadow. How tall is the building?
8. Priya and Meera are standing next to each other. Priya casts a 10 ft shadow and Meera casts an 8 ft shadow. Who is taller? How do you know?
9. Billy is 5 ft 9 inches tall and Bobby is 6 ft tall. Bobby's shadow is 13 feet long. How long is Billy's shadow?
10. Sally and her little brother are walking to school. Sally is 4 ft tall and has a shadow that is 3 ft long. Her little brother's shadow is 2 ft long. How tall is her little brother?
11. Ray is outside playing basketball. He is 5 ft tall and at this time of day is casting a 12 ft shadow. The basketball hoop is 10 ft tall. How long is the basketball hoop's shadow?
12. Jack is standing next to a very tall tree and wonders just how tall it is. He knows that he is 6 ft tall and at this moment his shadow is 8 ft long. He measures the shadow of the tree and finds it is 90 ft. How tall is the tree?
13. Jason, who is 4 ft 9 inches tall is casting a 6 ft shadow. A nearby building is casting a 42 ft shadow. How tall is the building?
14. Alexandra, who is 5 ft 8 in tall is casting a 12 ft shadow. A nearby lamppost is casting a 20 ft shadow. How tall is the lamppost?
15. Use shadows or a mirror to measure the height of an object in your yard or on the school grounds. Draw a picture to illustrate your method.

7.6 SSS Similarity

Here you'll learn how to decide whether or not two triangles are similar using SSS Similarity.

What if you were given a pair of triangles and the side lengths for all three of their sides? How could you use this information to determine if the two triangles are similar? After completing this Concept, you'll be able to use the SSS Similarity Theorem to decide if two triangles are similar.

Watch This



MEDIA

Click image to the left for more content.

[CK-12 Foundation: Chapter7SSSSimilarityA](#)

Watch this video beginning at the 2:09 mark.

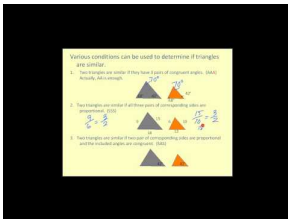

MEDIA

Click image to the left for more content.

[James Sousa:SimilarTriangles](#)

Watch the first part of this video.

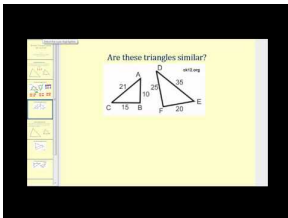

MEDIA

Click image to the left for more content.

[James Sousa:SimilarTriangles UsingSSSandSAS](#)

Guidance

If you do not know any angle measures, can you say two triangles are similar? Let's investigate this to see.

Investigation: SSS Similarity

Tools Needed: ruler, compass, protractor, paper, pencil

1. Construct a triangle with sides 6 cm, 8 cm, and 10 cm.

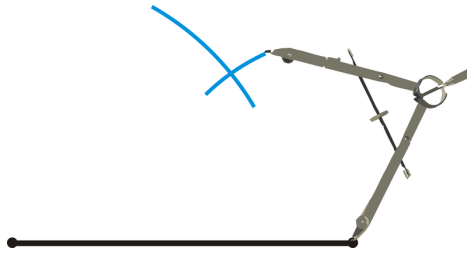

2. Construct a second triangle with sides 9 cm, 12 cm, and 15 cm.
3. Using your protractor, measure the angles in both triangles. What do you notice?
4. Line up the corresponding sides. Write down the ratios of these sides. What happens?

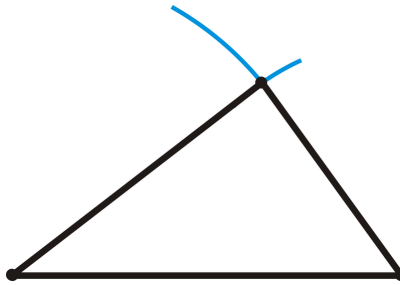

To see an animated construction of this, click: <http://www.mathsisfun.com/geometry/construct-ruler-compass-1.html>

From #3, you should notice that the angles in the two triangles are equal. Second, when the corresponding sides are lined up, the sides are all in the same proportion, $\frac{6}{9} = \frac{8}{12} = \frac{10}{15}$. If you were to repeat this activity, for a 3-4-5 or 12-16-20 triangle, you will notice that they are all similar. That is because, each of these triangles are multiples of 3-4-5. If we generalize what we found in this investigation, we have the SSS Similarity Theorem.

SSS Similarity Theorem: If the corresponding sides of two triangles are proportional, then the two triangles are similar.

Example A

Determine if the following triangles are similar. If so, explain why and write the similarity statement.

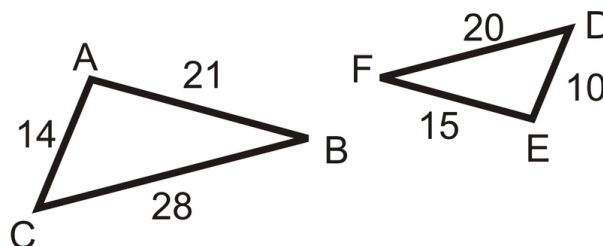

We will need to find the ratios for the corresponding sides of the triangles and see if they are all the same. Start with the longest sides and work down to the shortest sides.

$$\frac{BC}{FD} = \frac{28}{20} = \frac{7}{5}$$

$$\frac{BA}{FE} = \frac{21}{15} = \frac{7}{5}$$

$$\frac{AC}{ED} = \frac{14}{10} = \frac{7}{5}$$

Since all the ratios are the same, $\triangle ABC \sim \triangle EFD$ by the SSS Similarity Theorem.

Example B

Find x and y , such that $\triangle ABC \sim \triangle DEF$.

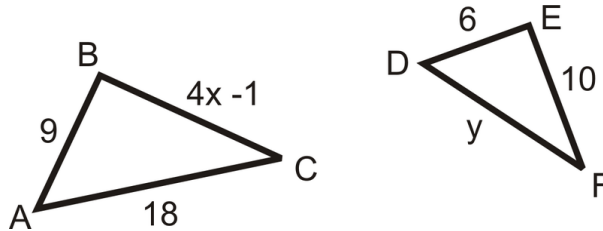

According to the similarity statement, the corresponding sides are: $\frac{AB}{DE} = \frac{BC}{EF} = \frac{AC}{DF}$. Substituting in what we know, we have $\frac{9}{6} = \frac{4x-1}{10} = \frac{18}{y}$.

$$\begin{aligned} \frac{9}{6} &= \frac{4x-1}{10} & \frac{9}{6} &= \frac{18}{y} \\ 9(10) &= 6(4x-1) & 9y &= 18(6) \\ 90 &= 24x-6 & 9y &= 108 \\ 96 &= 24x & y &= 12 \\ x &= 4 \end{aligned}$$

Example C

Determine if the following triangles are similar. If so, explain why and write the similarity statement.

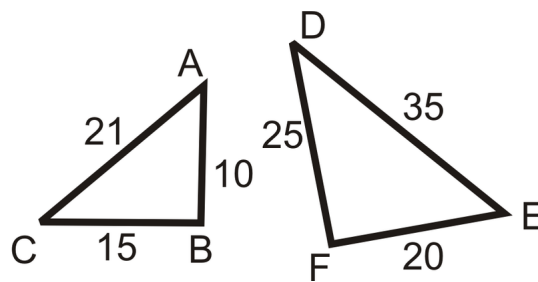

We will need to find the ratios for the corresponding sides of the triangles and see if they are all the same. Start with the longest sides and work down to the shortest sides.

$$\frac{AC}{ED} = \frac{21}{35} = \frac{3}{5}$$

$$\frac{BC}{FD} = \frac{15}{25} = \frac{3}{5}$$

$$\frac{AB}{EF} = \frac{10}{20} = \frac{1}{2}$$

Since the ratios are not all the same, the triangles are not similar.

Watch this video for help with the Examples above.



MEDIA

Click image to the left for more content.

CK-12 Foundation: Chapter7SSSSimilarityB

Vocabulary

Two triangles are *similar* if all their corresponding angles are *congruent* (exactly the same) and their corresponding sides are *proportional* (in the same ratio).

Guided Practice

Determine if any of the triangles below are similar. Compare two triangles at a time.

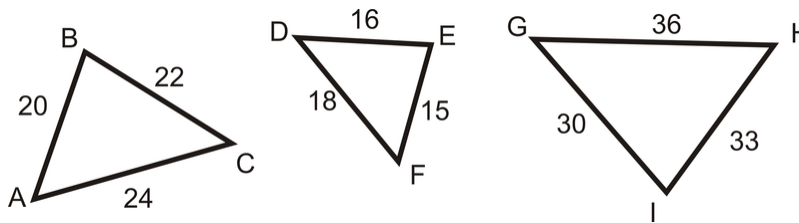

1. Is $\triangle ABC \sim \triangle DEF$?
2. Is $\triangle DEF \sim \triangle GHI$?
3. Is $\triangle ABC \sim \triangle GHI$?

Answers:

1. $\triangle ABC$ and $\triangle DEF$: Is $\frac{20}{15} = \frac{22}{16} = \frac{24}{18}$?

Reduce each fraction to see if they are equal. $\frac{20}{15} = \frac{4}{3}$, $\frac{22}{16} = \frac{11}{8}$, and $\frac{24}{18} = \frac{4}{3}$.

$\frac{4}{3} \neq \frac{11}{8}$, $\triangle ABC$ and $\triangle DEF$ are **not** similar.

2. $\triangle DEF$ and $\triangle GHI$: Is $\frac{15}{30} = \frac{16}{33} = \frac{18}{36}$?

$\frac{15}{30} = \frac{1}{2}$, $\frac{16}{33} = \frac{16}{33}$, and $\frac{18}{36} = \frac{1}{2}$. $\frac{1}{2} \neq \frac{16}{33}$, $\triangle DEF$ is **not** similar to $\triangle GHI$.

3. $\triangle ABC$ and $\triangle GHI$: Is $\frac{20}{30} = \frac{22}{33} = \frac{24}{36}$?

$\frac{20}{30} = \frac{2}{3}$, $\frac{22}{33} = \frac{2}{3}$, and $\frac{24}{36} = \frac{2}{3}$. All three ratios reduce to $\frac{2}{3}$, $\triangle ABC \sim \triangle GHI$.

Practice

Fill in the blanks.

1. If all three sides in one triangle are _____ to the three sides in another, then the two triangles are similar.
2. Two triangles are similar if the corresponding sides are _____.

Use the following diagram for questions 3-5. *The diagram is to scale.*

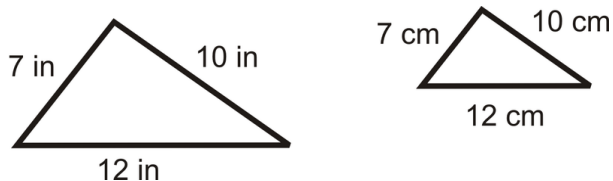

3. Are the two triangles similar? Explain your answer.
4. Are the two triangles congruent? Explain your answer.
5. What is the scale factor for the two triangles?

Fill in the blanks in the statements below. Use the diagram to the left.

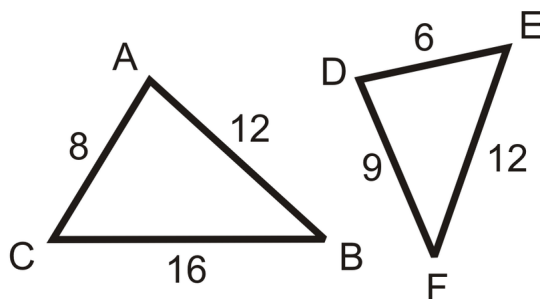

6. $\triangle ABC \sim \triangle$ _____
7. $\frac{AB}{?} = \frac{BC}{?} = \frac{AC}{?}$
8. If $\triangle ABC$ had an altitude, $AG = 10$, what would be the length of altitude \overline{DH} ?
9. Find the perimeter of $\triangle ABC$ and $\triangle DEF$. Find the ratio of the perimeters.

Use the diagram to the right for questions 10-15.

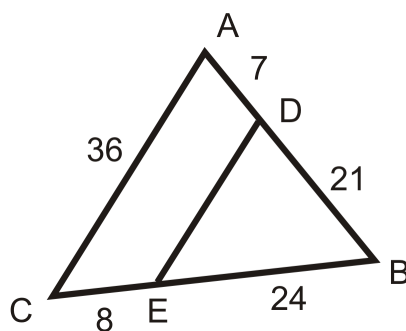

10. $\triangle ABC \sim \triangle$ _____
11. Why are the two triangles similar?
12. Find ED .
13. $\frac{BD}{?} = \frac{?}{BC} = \frac{DE}{?}$
14. Is $\frac{AD}{DB} = \frac{CE}{EB}$ true?
15. Is $\frac{AD}{DB} = \frac{AC}{DE}$ true?

Find the value of the missing variable(s) that makes the two triangles similar.

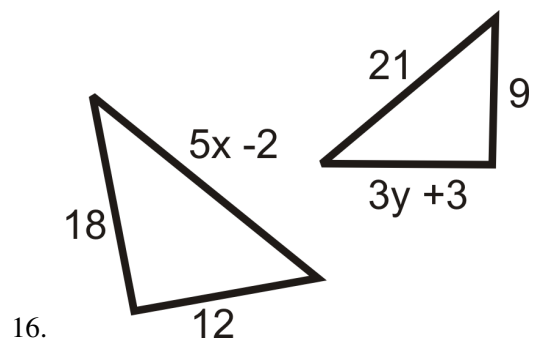

7.7 SAS Similarity

Here you'll learn how to decide whether or not two triangles are similar using SAS Similarity.

What if you were given a pair of triangles, the lengths of two of their sides, and the measure of the angle between those two sides? How could you use this information to determine if the two triangles are similar? After completing this Concept, you'll be able to use the SAS Similarity Theorem to decide if two triangles are similar.

Watch This



MEDIA

Click image to the left for more content.

CK-12 Foundation: Chapter7SASSimilarityA

Watch this video beginning at the 2:09 mark.

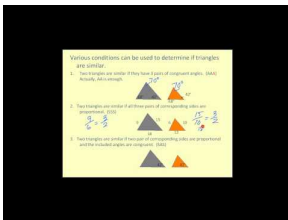

MEDIA

Click image to the left for more content.

James Sousa:SimilarTriangles

Watch the second part of this video.

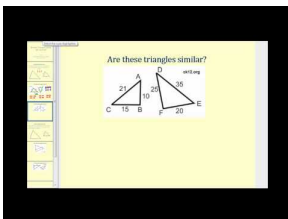

MEDIA

Click image to the left for more content.

James Sousa:SimilarTriangles UsingSSSandSAS

Guidance

If we know that two sides are proportional AND the included angles are congruent, then are the two triangles are similar? Let's investigate.

Investigation: SAS Similarity

Tools Needed: paper, pencil, ruler, protractor, compass

1. Construct a triangle with sides 6 cm and 4 cm and the *included* angle is 45° .

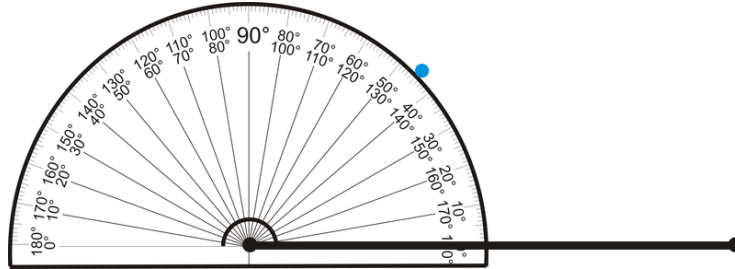

2. Repeat Step 1 and construct another triangle with sides 12 cm and 8 cm and the included angle is 45° .
3. Measure the other two angles in both triangles. What do you notice?

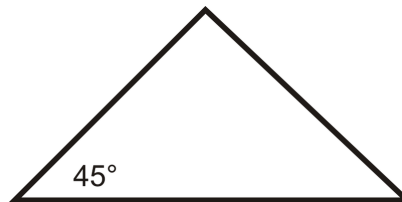

4. Measure the third side in each triangle. Make a ratio. Is this ratio the same as the ratios of the sides you were given?

SAS Similarity Theorem: If two sides in one triangle are proportional to two sides in another triangle and the included angle in the first triangle is congruent to the included angle in the second, then the two triangles are similar.

In other words, if $\frac{AB}{XY} = \frac{AC}{XZ}$ and $\angle A \cong \angle X$, then $\triangle ABC \sim \triangle XYZ$.

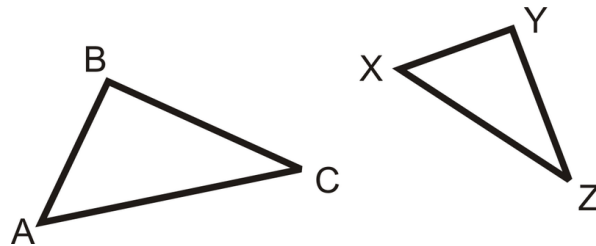
**Example A**

Are the two triangles similar? How do you know?

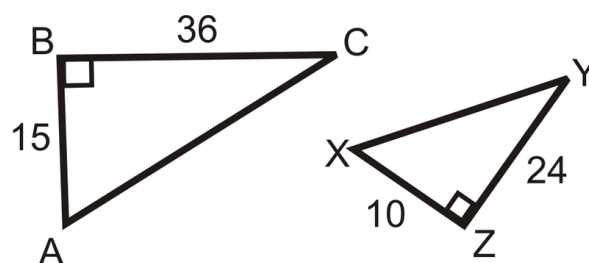

$\angle B \cong \angle Z$ because they are both right angles. Second, $\frac{10}{15} = \frac{24}{36}$ because they both reduce to $\frac{2}{3}$. Therefore, $\frac{AB}{XZ} = \frac{BC}{ZY}$ and $\triangle ABC \sim \triangle XZY$.

Notice with this example that we can find the third sides of each triangle using the Pythagorean Theorem. If we were to find the third sides, $AC = 39$ and $XY = 26$. The ratio of these sides is $\frac{26}{39} = \frac{2}{3}$.

Example B

Are there any similar triangles? How do you know?

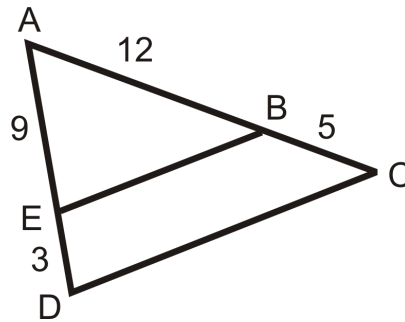

$\angle A$ is shared by $\triangle EAB$ and $\triangle DAC$, so it is congruent to itself. If $\frac{AE}{AD} = \frac{AB}{AC}$ then, by SAS Similarity, the two triangles would be similar.

$$\frac{9}{9+3} = \frac{12}{12+5}$$

$$\frac{9}{12} = \frac{3}{4} \neq \frac{12}{17}$$

Because the proportion is not equal, the two triangles are not similar.

Example C

From Example B, what should BC equal for $\triangle EAB \sim \triangle DAC$?

The proportion we ended up with was $\frac{9}{12} = \frac{3}{4} \neq \frac{12}{17}$. AC needs to equal 16, so that $\frac{12}{16} = \frac{3}{4}$. Therefore, $AC = AB + BC$ and $16 = 12 + BC$. BC should equal 4 in order for $\triangle EAB \sim \triangle DAC$.

Watch this video for help with the Examples above.



MEDIA

Click image to the left for more content.

[CK-12 Foundation: Chapter7SASSimilarityB](#)

Vocabulary

Two triangles are **similar** if all their corresponding angles are **congruent** (exactly the same) and their corresponding sides are **proportional** (in the same ratio).

Guided Practice

Determine if the following triangles are similar. If so, write the similarity theorem and statement.

1.

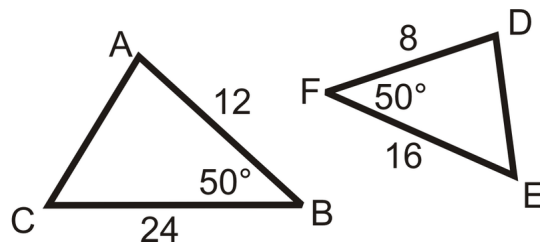

2.

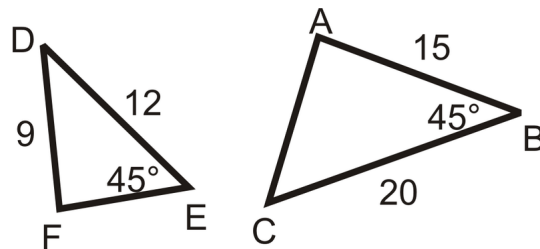

3.

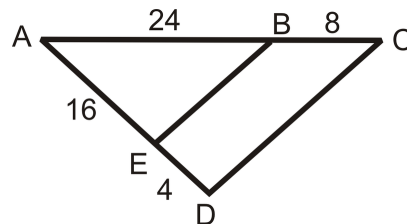

Answers:

1. We can see that $\angle B \cong \angle F$ and these are both included angles. We just have to check that the sides around the angles are proportional.

$$\frac{AB}{DF} = \frac{12}{8} = \frac{3}{2}$$

$$\frac{BC}{FE} = \frac{24}{16} = \frac{3}{2}$$

Since the ratios are the same $\triangle ABC \sim \triangle DFE$ by the SAS Similarity Theorem.

2. The triangles are not similar because the angle is not the included angle for both triangles.

3. $\angle A$ is the included angle for both triangles, so we have a pair of congruent angles. Now we have to check that the sides around the angles are proportional.

$$\frac{AE}{AD} = \frac{16}{16+4} = \frac{16}{20} = \frac{4}{5}$$

$$\frac{AB}{AC} = \frac{24}{24+8} = \frac{24}{32} = \frac{3}{4}$$

The ratios are not the same so the triangles are not similar.

Practice

Fill in the blanks.

1. If two sides in one triangle are _____ to two sides in another and the _____ angles are _____, then the triangles are _____.

Determine if the following triangles are similar. If so, write the similarity theorem and statement.

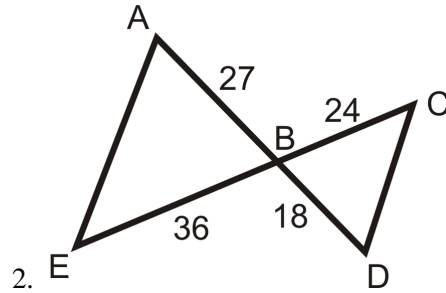

Find the value of the missing variable(s) that makes the two triangles similar.

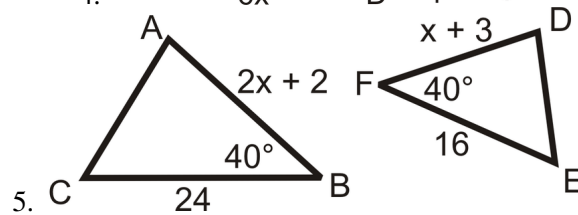
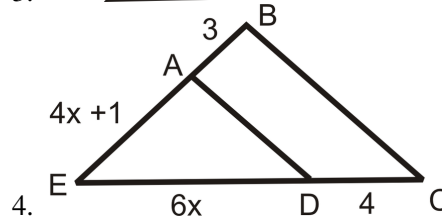
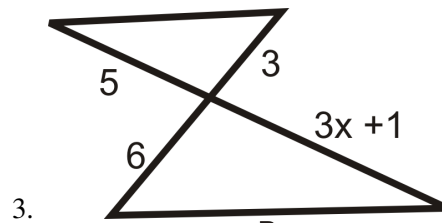

Determine if the triangles are similar.

6. $\triangle ABC$ is a right triangle with legs that measure 3 and 4. $\triangle DEF$ is a right triangle with legs that measure 6 and 8.
7. $\triangle GHI$ is a right triangle with a leg that measures 12 and a hypotenuse that measures 13. $\triangle JKL$ is a right triangle with legs that measure 1 and 2.

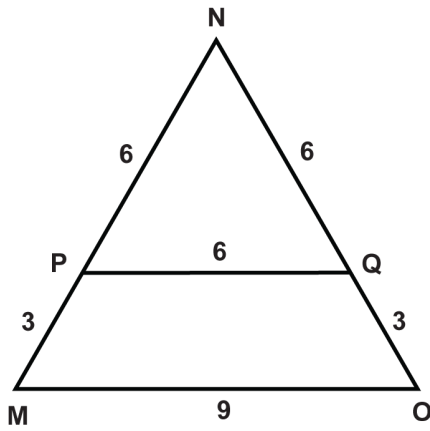

8.

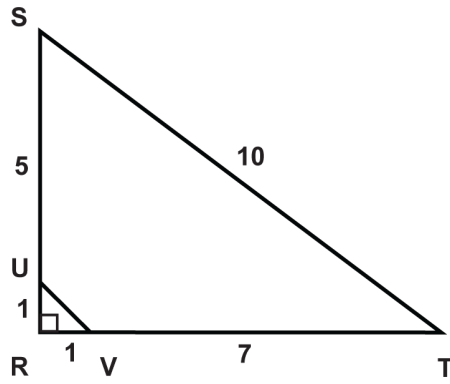

9.

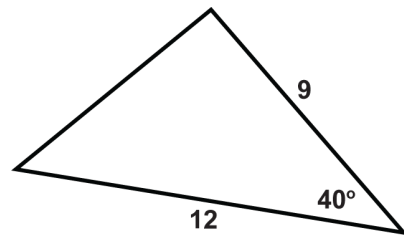
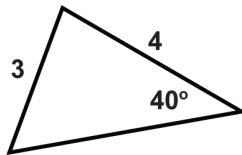

10.

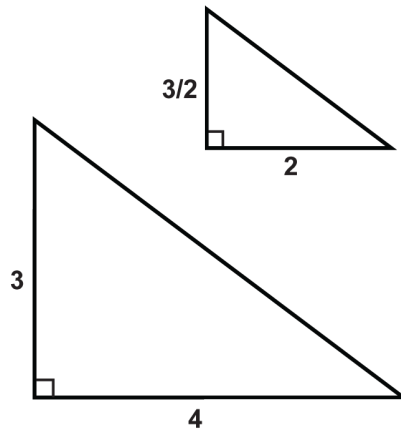

11.

12. $\overline{AC} = 3$

$\overline{DF} = 6$

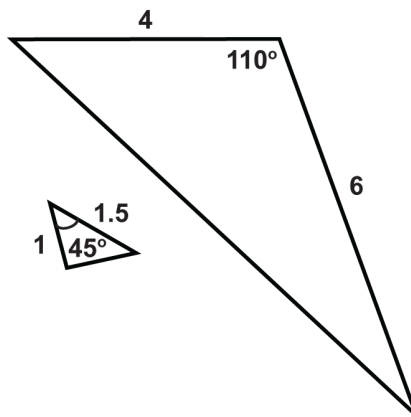
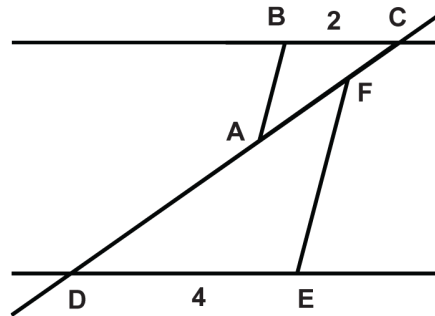

13.

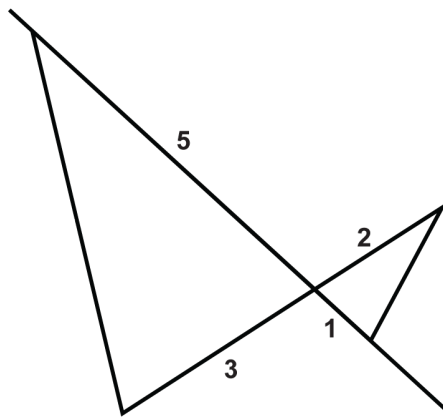

14.

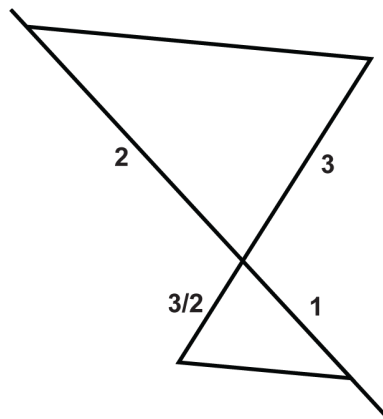

15.

7.8 Triangle Proportionality

Here you'll learn how to apply both the Triangle Proportionality Theorem, which states that if a line that is parallel to one side of a triangle intersects the other two sides, then it divides those sides proportionally.

What if you were given a triangle with a line segment drawn through it from one side to the other? How could you use information about the triangle's side lengths to determine if that line segment is parallel to the third side? After completing this Concept, you'll be able to answer questions like this one.

Watch This



MEDIA

Click image to the left for more content.

[CK-12 Foundation: Chapter7TriangleProportionalityA](#)

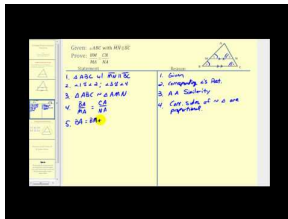

MEDIA

Click image to the left for more content.

[James Sousa:Triangle Proportionality Theorem](#)

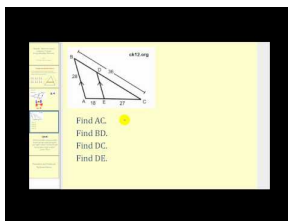

MEDIA

Click image to the left for more content.

[James Sousa:Using the Triangle Proportionality Theorem to SolveforUnknownValues](#)

Guidance

Think about a midsegment of a triangle. A midsegment is parallel to one side of a triangle and divides the other two sides into congruent halves. The midsegment divides those two sides **proportionally**.

Investigation: Triangle Proportionality

Tools Needed: pencil, paper, ruler

1. Draw $\triangle ABC$. Label the vertices.
2. Draw \overline{XY} so that X is on \overline{AB} and Y is on \overline{BC} . X and Y can be *anywhere* on these sides.

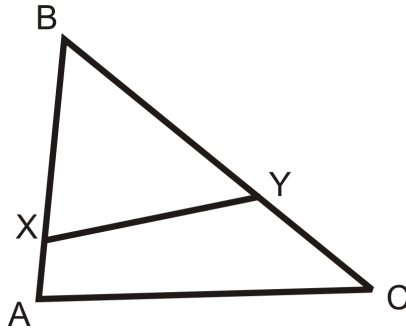

3. Is $\triangle XBY \sim \triangle ABC$? Why or why not? Measure AX , XB , BY , and YC . Then set up the ratios $\frac{AX}{XB}$ and $\frac{YC}{YB}$. Are they equal?
4. Draw a second triangle, $\triangle DEF$. Label the vertices.
5. Draw \overline{XY} so that X is on \overline{DE} and Y is on \overline{EF} AND $\overline{XY} \parallel \overline{DF}$.
6. Is $\triangle XEY \sim \triangle DEF$? Why or why not? Measure DX , XE , EY , and YF . Then set up the ratios $\frac{DX}{XE}$ and $\frac{FY}{YE}$. Are they equal?

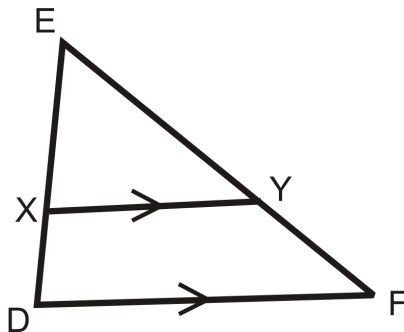

From this investigation, it is clear that if the line segments are parallel, then \overline{XY} divides the sides proportionally.

Triangle Proportionality Theorem: If a line parallel to one side of a triangle intersects the other two sides, then it divides those sides proportionally.

Triangle Proportionality Theorem Converse: If a line divides two sides of a triangle proportionally, then it is parallel to the third side.

Proof of the Triangle Proportionality Theorem:

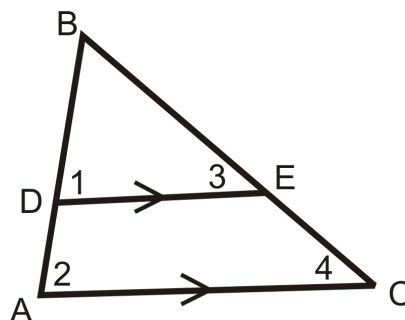

Given: $\triangle ABC$ with $\overline{DE} \parallel \overline{AC}$

Prove: $\frac{AD}{DB} = \frac{CE}{EB}$

TABLE 7.2:

| Statement | Reason |
|--|---|
| 1. $\overline{DE} \parallel \overline{AC}$ | Given |
| 2. $\angle 1 \cong \angle 2, \angle 3 \cong \angle 4$ | Corresponding Angles Postulate |
| 3. $\triangle ABC \sim \triangle DBE$ | AA Similarity Postulate |
| 4. $AD + DB = AB, EC + EB = BC$ | Segment Addition Postulate |
| 5. $\frac{AB}{BD} = \frac{BC}{BE}$ | Corresponding sides in similar triangles are proportional |
| 6. $\frac{AD+DB}{BD} = \frac{EC+EB}{BE}$ | Substitution PoE |
| 7. $\frac{AD}{BD} + \frac{DB}{DB} = \frac{EC}{BE} + \frac{BE}{BE}$ | Separate the fractions |
| 8. $\frac{AD}{BD} + 1 = \frac{EC}{BE} + 1$ | Substitution PoE (something over itself always equals 1) |
| 9. $\frac{AD}{BD} = \frac{EC}{BE}$ | Subtraction PoE |

Example A

A triangle with its midsegment is drawn below. What is the ratio that the midsegment divides the sides into?

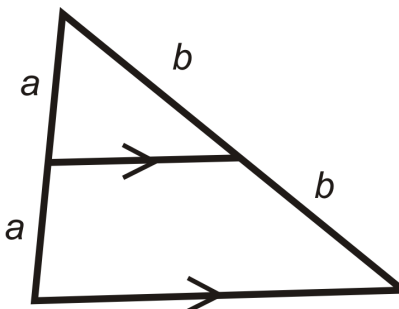

The midsegment's endpoints are the midpoints of the two sides it connects. The midpoints split the sides evenly. Therefore, the ratio would be $a : a$ or $b : b$. Both of these reduce to 1:1.

Example B

In the diagram below, $\overline{EB} \parallel \overline{CD}$. Find BC .

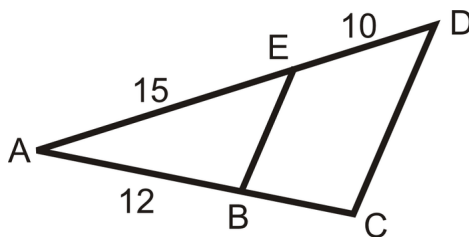

Use the Triangle Proportionality Theorem.

$$\frac{10}{15} = \frac{BC}{12} \rightarrow 15(BC) = 120$$

$$BC = 8$$

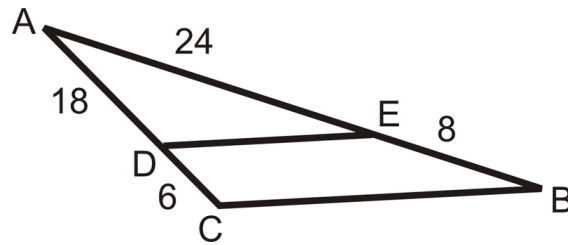
Example CIs $\overline{DE} \parallel \overline{CB}$?

Use the Triangle Proportionality Converse. If the ratios are equal, then the lines are parallel.

$$\frac{6}{18} = \frac{1}{3} \text{ and } \frac{8}{24} = \frac{1}{3}$$

Because the ratios are equal, $\overline{DE} \parallel \overline{CB}$.

Watch this video for help with the Examples above.

**MEDIA**

Click image to the left for more content.

[CK-12 Foundation: Chapter7TriangleProportionalityB](#)

Vocabulary

A line segment that connects two midpoints of the sides of a triangle is called a **midsegment**. A midpoint is a point that divides a segment into two equal pieces. Pairs of numbers are **proportional** if they are in the same ratio.

Guided Practice

Use the diagram to answer questions 1-5. $\overline{DB} \parallel \overline{FE}$.

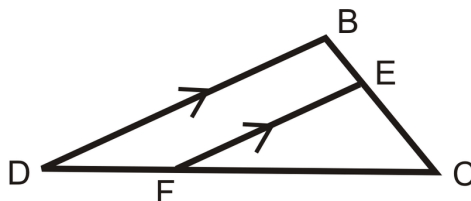

1. Name the similar triangles. Write the similarity statement.

2. $\frac{BE}{EC} = \frac{?}{FC}$
3. $\frac{EC}{CB} = \frac{CF}{?}$
4. $\frac{DB}{?} = \frac{BC}{EC}$
5. $\frac{FC+?}{FC} = \frac{?}{FE}$

Answers:

1. $\triangle DBC \sim \triangle FEC$
2. DF
3. DC
4. FE
5. DF; DB

Practice

Use the diagram to answer questions 1-5. $\overline{AB} \parallel \overline{DE}$.

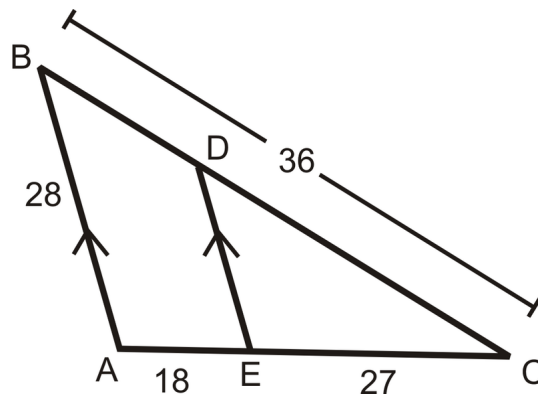

1. Find BD .
2. Find DC .
3. Find DE .
4. Find AC .
5. What is $BD : DC$?
6. What is $DC : BC$?
7. We know that $\frac{BD}{DC} = \frac{AE}{EC}$ and $\frac{BA}{DE} = \frac{BC}{DC}$. Why is $\frac{BA}{DE} \neq \frac{BD}{DC}$?

Use the given lengths to determine if $\overline{AB} \parallel \overline{DE}$.

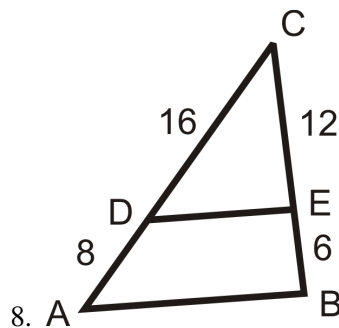

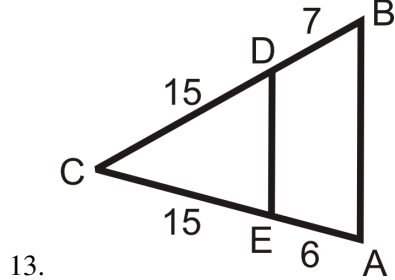
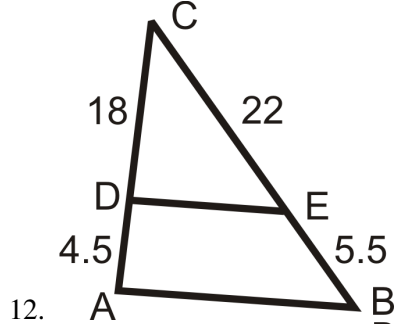
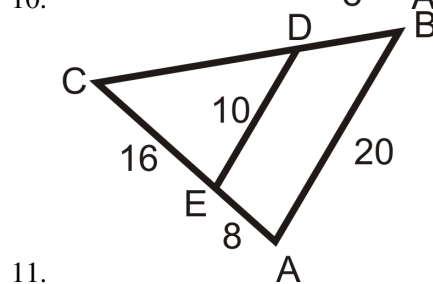
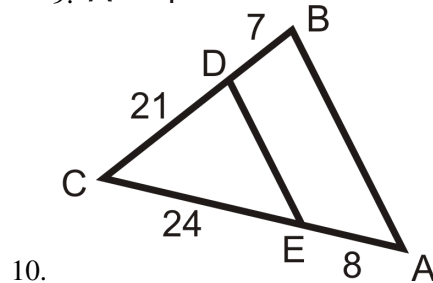
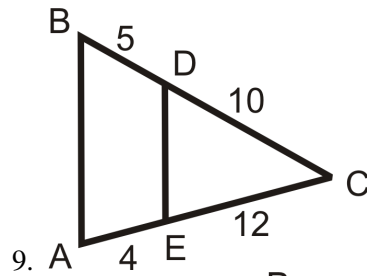

Find the unknown length.

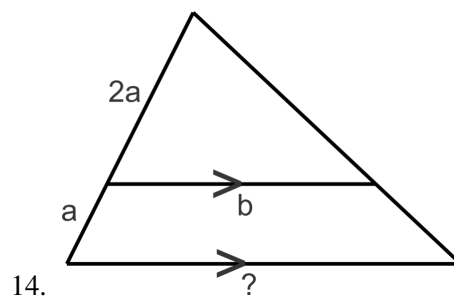

15. What is the ratio that the midsegment divides the sides into?

7.9 Parallel Lines and Transversals

Here you'll learn how to use the Triangle Proportionality Theorem with multiple parallel lines.

What if you were given the street map, below, of Washington DC and told to find the missing street lengths? *R* Street, *Q* Street, and *O* Street are parallel and 7th Street is perpendicular to all three. *R* and *Q* are one “city block” (usually $\frac{1}{4}$ mile or 1320 feet) apart. The other given measurements are on the map. What are x and y ? After completing this Concept, you'll be able to solve problems like this one.

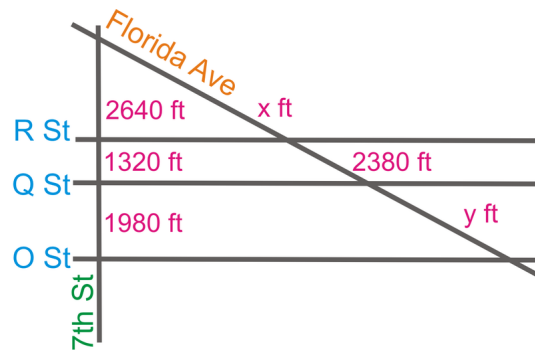

Watch This



MEDIA

Click image to the left for more content.

CK-12 Foundation: Chapter7ParallelLinesandTransversalsA

Learn more aboutproportional segments between parallel lines bywatching the video at this link.

Guidance

The **Triangle Proportionality Theorem** states that if a line parallel to one side of a triangle intersects the other two sides, then it divides those sides proportionally. We can extend this theorem to a situation outside of triangles where we have multiple parallel lines cut by transversals.

Theorem: If three or more parallel lines are cut by two transversals, then they divide the transversals proportionally.

Example A

Find a .

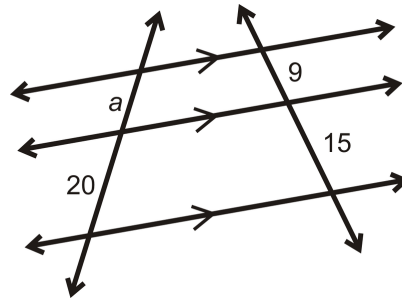

The three lines are marked parallel, so you can set up a proportion.

$$\begin{aligned}\frac{a}{20} &= \frac{9}{15} \\ 180 &= 15a \\ a &= 12\end{aligned}$$

Example B

Find b .

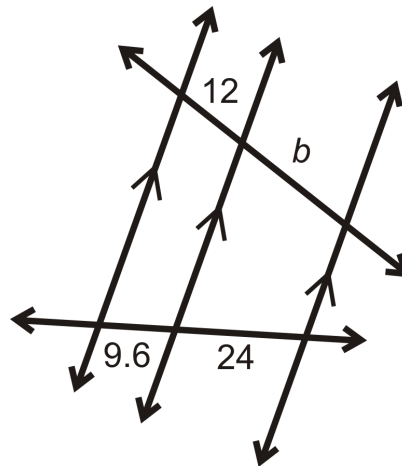

To solve, set up a proportion.

$$\begin{aligned}\frac{12}{9.6} &= \frac{b}{24} \\ 288 &= 9.6b \\ b &= 30\end{aligned}$$

Example C

Find the value of x that makes the lines parallel.

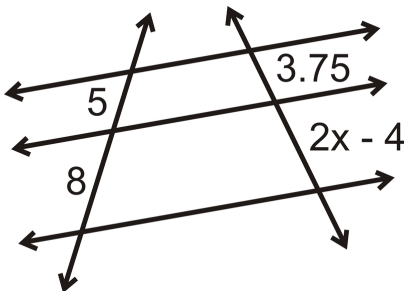

To solve, set up a proportion and solve for x .

$$\begin{aligned} \frac{5}{8} &= \frac{3.75}{2x-4} \rightarrow 5(2x-4) = 8(3.75) \\ 10x - 20 &= 30 \\ 10x &= 50 \\ x &= 5 \end{aligned}$$

Watch this video for help with the Examples above.



MEDIA

Click image to the left for more content.

[CK-12 Foundation: Chapter7ParallelLinesandTransversalsB](#)

Concept Problem Revisited

To find x and y , you need to set up a proportion using parallel the parallel lines.

$$\frac{2640}{x} = \frac{1320}{2380} = \frac{1980}{y}$$

From this, $x = 4760$ ft and $y = 3570$ ft.

To find a , b , and c , use the Pythagorean Theorem.

$$\begin{aligned} 2640^2 + a^2 &= 4760^2 \\ 3960^2 + b^2 &= 7140^2 \\ 5940^2 + c^2 &= 10710^2 \end{aligned}$$

$$a = 3960.81, b = 5941.21, c = 8911.82$$

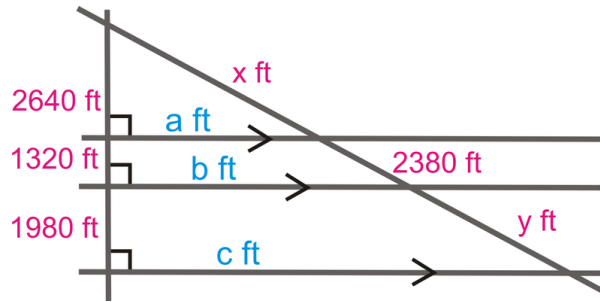

Vocabulary

Pairs of numbers are **proportional** if they are in the same ratio. Two lines are **parallel** if they have the same slope and thus never intersect. A **transversal** is a line intersecting a system of lines.

Guided Practice

Find a , b , and c .

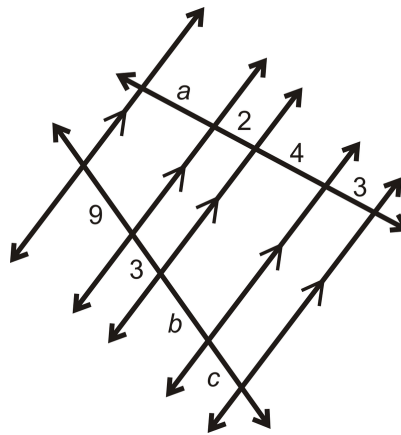

Look at the corresponding segments. Only the segment marked “2” is opposite a number, all the other segments are opposite variables. That means we will be using this ratio, 2:3 in all of our proportions.

$$\begin{array}{l} \frac{a}{2} = \frac{9}{3} \\ 3a = 18 \\ a = 6 \end{array} \qquad \begin{array}{l} \frac{2}{4} = \frac{3}{b} \\ 2b = 12 \\ b = 6 \end{array} \qquad \begin{array}{l} \frac{2}{3} = \frac{3}{c} \\ 2c = 9 \\ c = 4.5 \end{array}$$

There are several ratios you can use to solve this example. To solve for b , you could have used the proportion $\frac{6}{4} = \frac{9}{b}$, which will still give you the same answer.

Practice

Find the value of each variable in the pictures below.

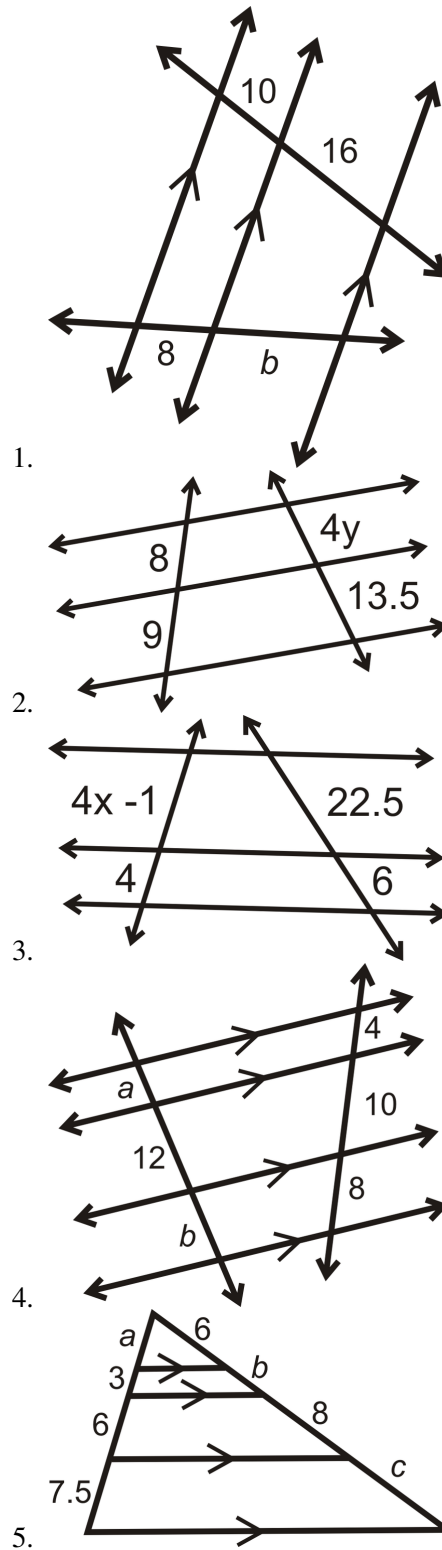

The street map shows part of New Orleans. Burgundy St., Dauphine St. and Royal St. are parallel to each other. If Spain St. is perpendicular to all three, find the indicated distances.

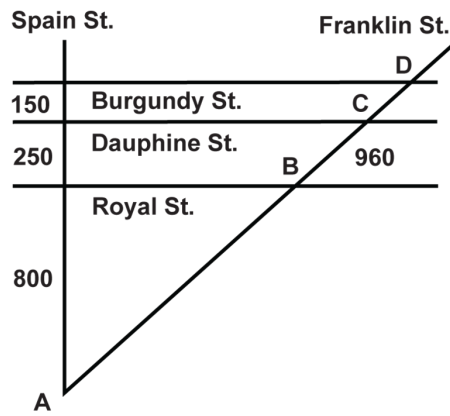

6. What is the distance between points A and B ?
7. What is the distance between points C and D ?
8. What is the distance between points A and D ?

Using the diagram, answer the questions.

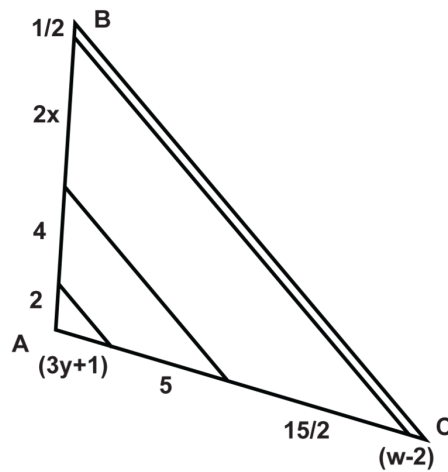

9. What is the value of w ?
10. What is the value of x ?
11. What is the value of y ?
12. What is the length of \overline{AB} ?
13. What is the length of \overline{AC} ?

Using the diagram, fill in the blank.

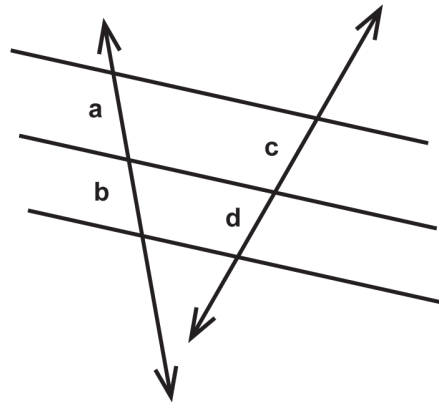

14. If b is one-third d , then a is _____.
15. If c is two times a , then b is _____.

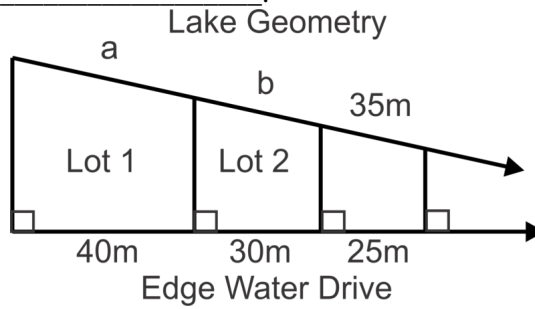

This is a map of lake front properties. Find a and b , the length of the edge of Lot 1 and Lot 2 that is adjacent to the lake.

7.10 Proportions with Angle Bisectors

Here you'll learn how to set up and solve proportions with angle bisectors.

What if you were told that a ray was an angle bisector of a triangle? How would you use this fact to find unknown values regarding the triangle's side lengths? After completing this Concept, you'll be able to solve such problems.

Watch This



MEDIA

Click image to the left for more content.

CK-12 Foundation: Chapter7ProportionswithAngleBisectorsA

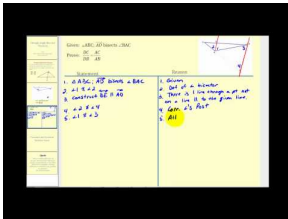

MEDIA

Click image to the left for more content.

James Sousa:Triangle Angle BisectorTheorem

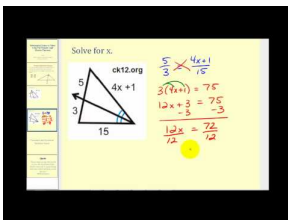

MEDIA

Click image to the left for more content.

James Sousa:Using the Triangle Angle Bisector Theorem to Determine Unknown Values

Guidance

When an angle within a triangle is bisected, the bisector divides the triangle proportionally

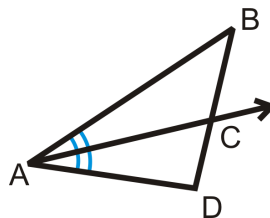

By definition, \overrightarrow{AC} divides $\angle BAD$ equally, so $\angle BAC \cong \angle CAD$. The proportional relationship is $\frac{BC}{CD} = \frac{AB}{AD}$.

Theorem: If a ray bisects an angle of a triangle, then it divides the opposite side into segments that are proportional to the lengths of the other two sides.

Example A

Find x .

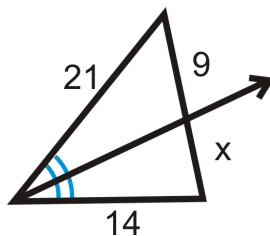

Because the ray is the angle bisector it splits the opposite side in the same ratio as the sides. So, the proportion is:

$$\begin{aligned}\frac{9}{x} &= \frac{21}{14} \\ 21x &= 126 \\ x &= 6\end{aligned}$$

Example B

Determine the value of x that would make the proportion true.

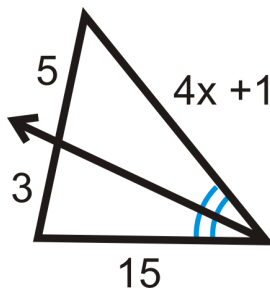

You can set up this proportion just like the previous example.

$$\begin{aligned}\frac{5}{3} &= \frac{4x+1}{15} \\ 75 &= 3(4x+1) \\ 75 &= 12x+3 \\ 72 &= 12x \\ 6 &= x\end{aligned}$$

Example C

Find the missing variable:

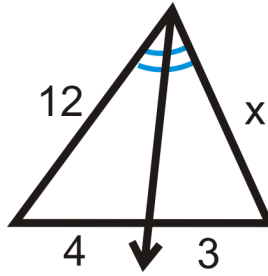

Set up a proportion and solve like in the previous examples.

$$\begin{aligned}\frac{12}{4} &= \frac{x}{3} \\ 36 &= 4x \\ x &= 9\end{aligned}$$

Watch this video for help with the Examples above.



MEDIA

Click image to the left for more content.

[CK-12 Foundation: Chapter7ProportionswithAngleBisectorsB](#)

Vocabulary

Pairs of numbers are *proportional* if they are in the same ratio. An *angle bisector* is a ray that divides an angle into two congruent angles.

Guided Practice

Find the missing variables:

1.

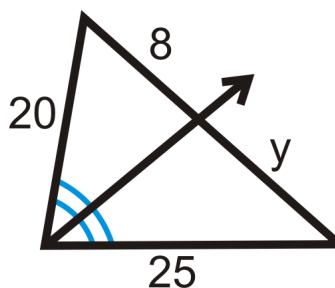

2.

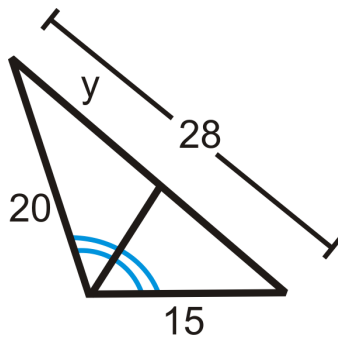

3.

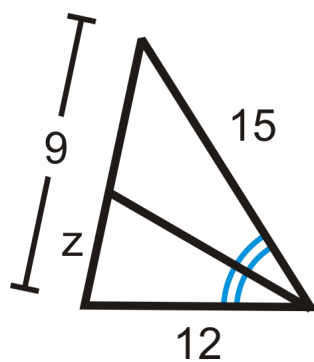
**Answers:**

1. Set up a proportion and solve.

$$\begin{aligned}\frac{20}{8} &= \frac{25}{y} \\ 20y &= 200 \\ y &= 10\end{aligned}$$

2. Set up a proportion and solve.

$$\begin{aligned}\frac{20}{y} &= \frac{15}{28-y} \\ 15y &= 20(28-y) \\ 15y &= 560 - 20y \\ 35y &= 560 \\ y &= 16\end{aligned}$$

3. Set up a proportion and solve.

$$\frac{12}{z} = \frac{15}{9-z}$$

$$15z = 12(9-z)$$

$$15z = 108 = 12z$$

$$27z = 108$$

$$z = 4$$

Practice

Find the value of the missing variable(s).

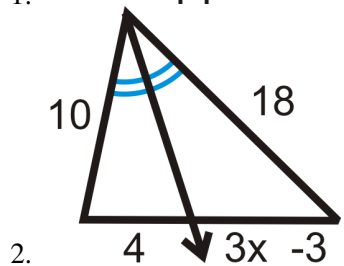
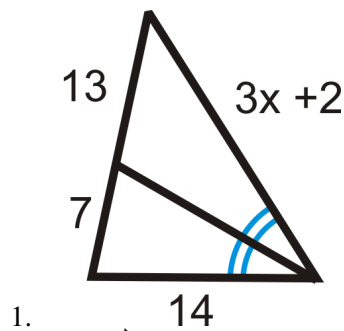

Find the value of each variable in the pictures below.

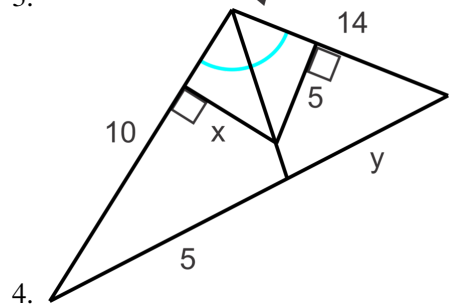
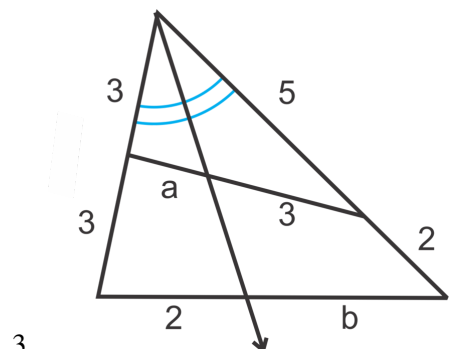

Find the unknown lengths.

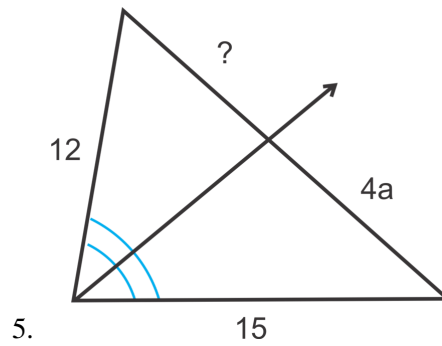

6. *Error Analysis*

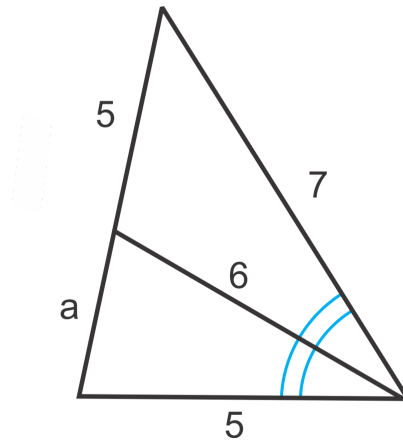

Casey attempts to solve for a in the diagram using the proportion $\frac{5}{a} = \frac{6}{5}$. What did Casey do wrong? Write the correct proportion and solve for a .

Solve for the unknown variable.

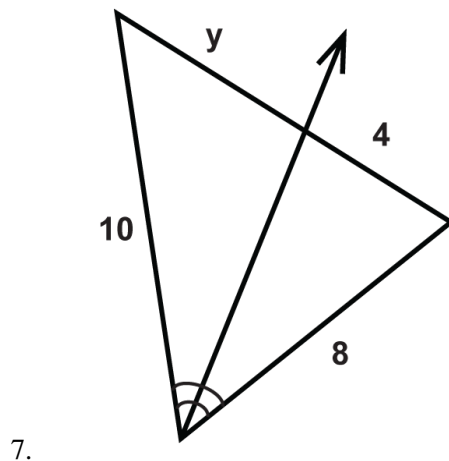

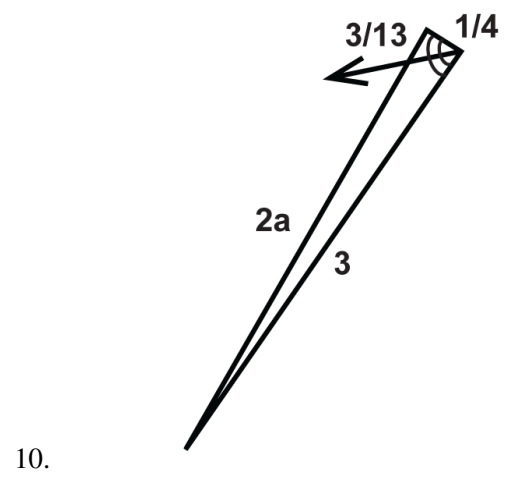
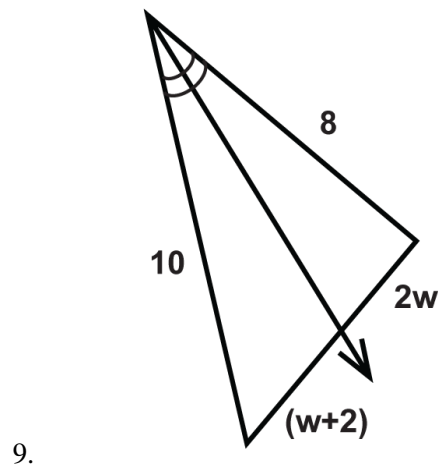
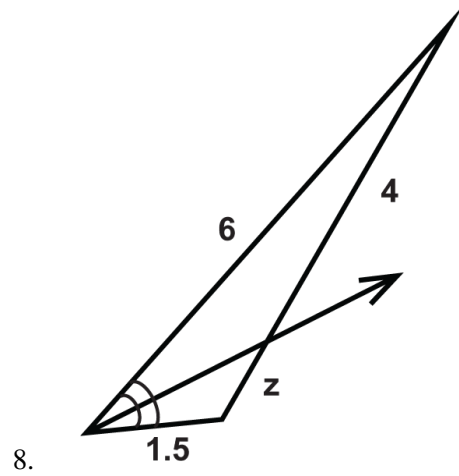

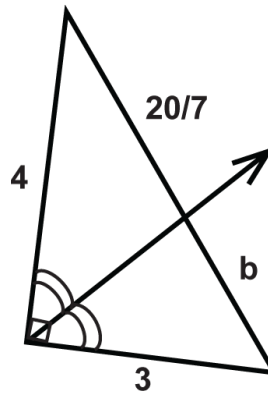

11.

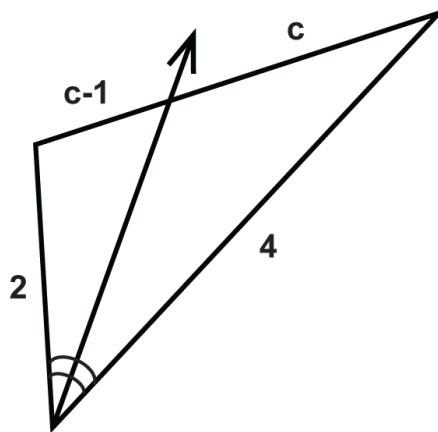

12.

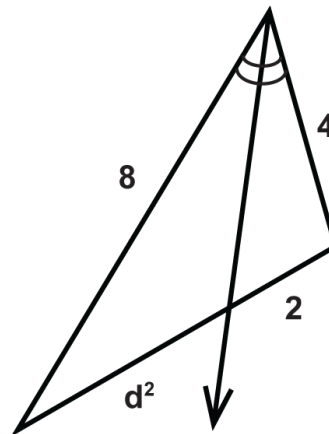

13.

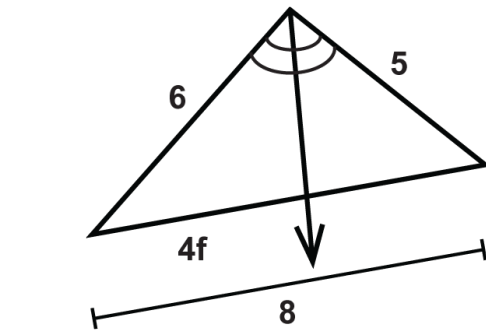
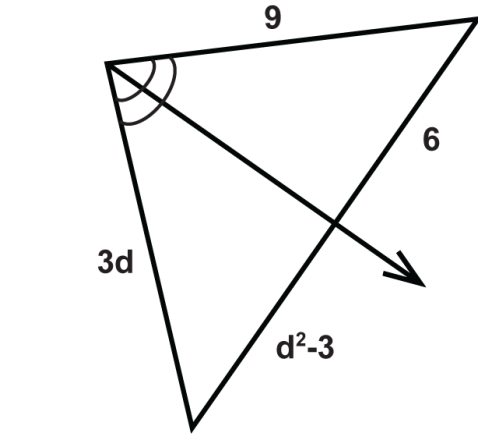
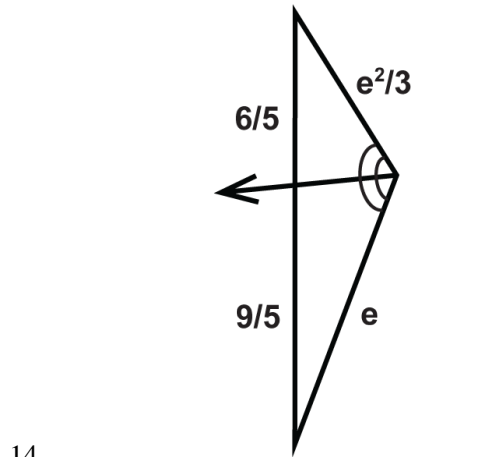

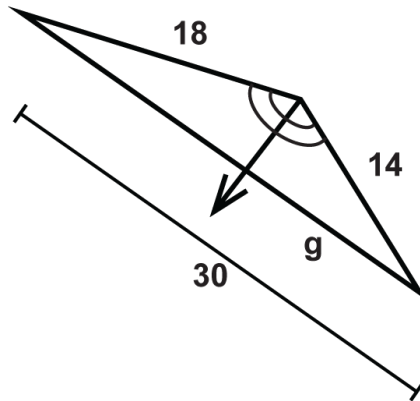

17.

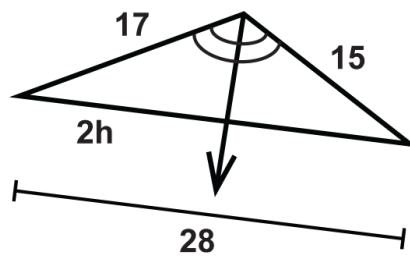

18.

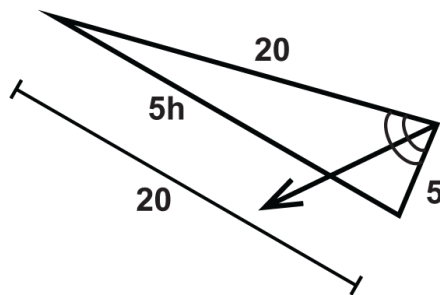

19.

7.11 Dilation

Here you'll learn what a dilation is, how to dilate a figure, and how to find the scale factor by which the figure is dilated.

What if you enlarged or reduced a triangle without changing its shape? How could you find the scale factor by which the triangle was stretched or shrunk? After completing this Concept, you'll be able to use the corresponding sides of dilated figures to solve problems like this one.

Watch This



MEDIA

Click image to the left for more content.

[CK-12 Foundation: Chapter7DilationA](#)

Learn more about dilations by watching the video at [this link](#).

Guidance

A **transformation** is an operation that moves, flips, or changes a figure to create a new figure. Transformations that preserve size are **rigid** and ones that do not are **non-rigid**. A **dilation** makes a figure larger or smaller, but has the same shape as the original. In other words, the dilation is similar to the original. All dilations have a **center** and a **scale factor**. The center is the point of reference for the dilation (like the vanishing point in a perspective drawing) and scale factor tells us how much the figure stretches or shrinks. A scale factor is typically labeled k and is always greater than zero. Also, if the original figure is labeled $\triangle ABC$, for example, the dilation would be $\triangle A'B'C'$. The ' indicates that it is a copy. This tic mark is said "prime," so A' is read "A prime." A second dilation would be A'' , read "A double-prime."

If the dilated image is smaller than the original, then the scale factor is $0 < k < 1$.

If the dilated image is larger than the original, then the scale factor is $k > 1$.

Example A

The center of dilation is P and the scale factor is 3. Find Q' .

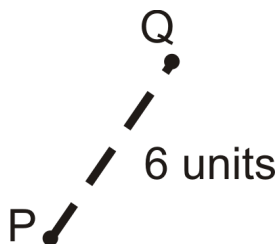

If the scale factor is 3 and Q is 6 units away from P , then Q' is going to be $6 \times 3 = 18$ units away from P . Because we are only dilating a point, the dilation will be collinear with the original and center.

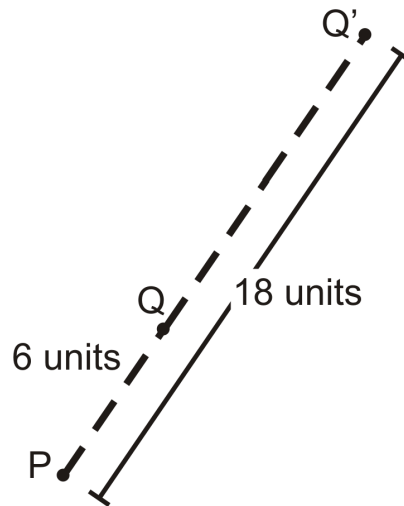

Example B

Using the picture above, change the scale factor to $\frac{1}{3}$. Find Q'' .

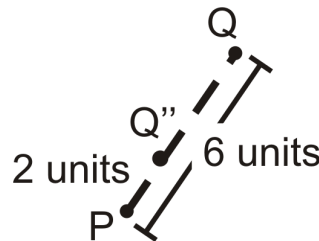

Now the scale factor is $\frac{1}{3}$, so Q'' is going to be $\frac{1}{3}$ the distance away from P as Q is. In other words, Q'' is going to be $6 \times \frac{1}{3} = 2$ units away from P . Q'' will also be collinear with Q and center.

Example C

$KLMN$ is a rectangle with length 12 and width 8. If the center of dilation is K with a scale factor of 2, draw $K'L'M'N'$.

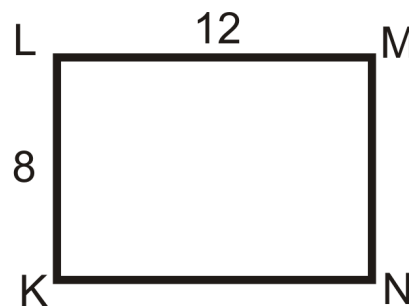

If K is the center of dilation, then K and K' will be the same point. From there, L' will be 8 units above L and N' will be 12 units to the right of N .

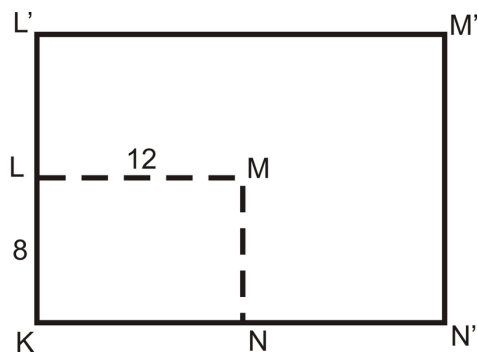

Watch this video for help with the Examples above.



MEDIA

Click image to the left for more content.

[CK-12 Foundation: Chapter7DilationB](#)

Vocabulary

A **dilation** is an enlargement or reduction of a figure that preserves shape but not size. All dilations are similar to the original figure. **Similar** figures are the same shape but not necessarily the same size. The **center of a dilation** is the point of reference for the dilation and the **scale factor** for a dilation tells us how much the figure stretches or shrinks.

Guided Practice

1. Find the perimeters of $KLMN$ and $K'L'M'N'$. Compare this ratio to the scale factor.

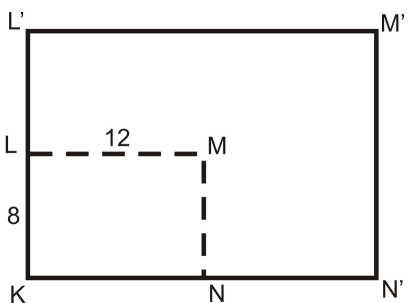
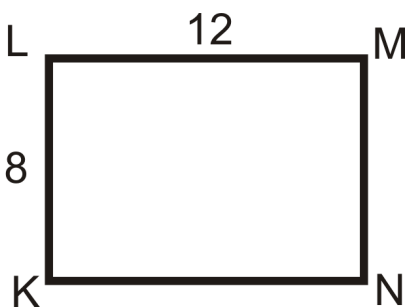

2. $\triangle ABC$ is a dilation of $\triangle DEF$. If P is the center of dilation, what is the scale factor?

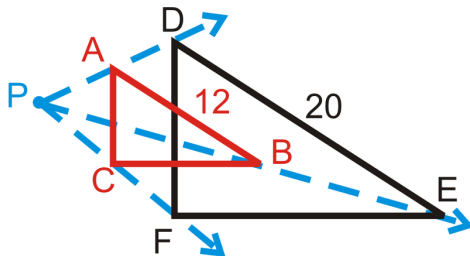

3. Find the scale factor, given the corresponding sides. In the diagram, the **black** figure is the original and P is the center of dilation.

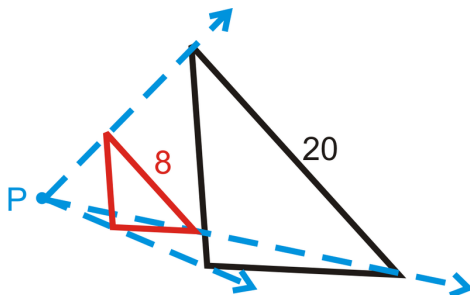

Answers:

1. The perimeter of $KLMN = 12 + 8 + 12 + 8 = 40$. The perimeter of $K'L'M'N' = 24 + 16 + 24 + 16 = 80$. The ratio is $80:40$, which reduces to $2:1$, which is the same as the scale factor.

2. Because $\triangle ABC$ is a dilation of $\triangle DEF$, then $\triangle ABC \sim \triangle DEF$. The scale factor is the ratio of the sides. Since $\triangle ABC$ is smaller than the original, $\triangle DEF$, the scale factor is going to be less than one, $\frac{12}{20} = \frac{3}{5}$.

If $\triangle DEF$ was the dilated image, the scale factor would have been $\frac{5}{3}$.

3. Since the dilation is smaller than the original, the scale factor is going to be less than one. $\frac{8}{20} = \frac{2}{5}$

Practice

In the two questions below, you are told the scale factor. Determine the dimensions of the dilation. In each diagram, the **black** figure is the original and P is the center of dilation.

1. $k = 4$

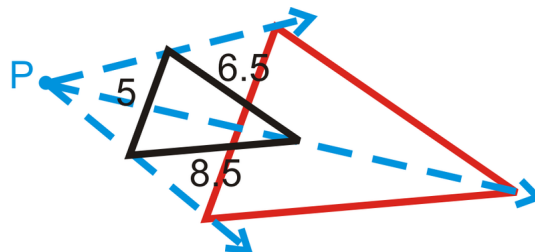

2. $k = \frac{1}{3}$

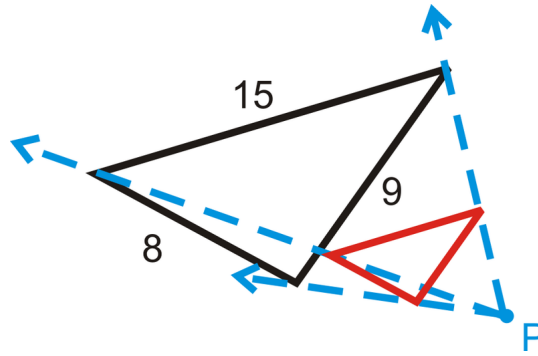

In the question below, find the scale factor, given the corresponding sides. In the diagram, the **black** figure is the original and P is the center of dilation.

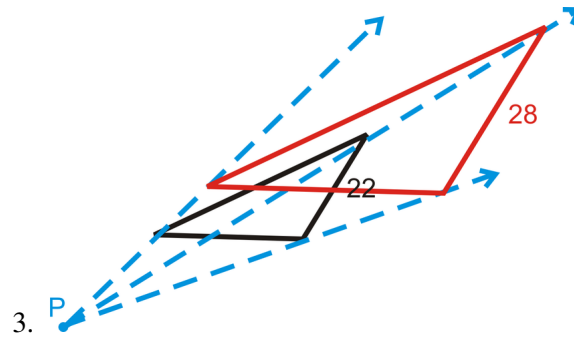

- 3.
4. Find the perimeter of both triangles in #1. What is the ratio of the perimeters?
5. **Writing** What happens if $k = 1$?

Construction We can use a compass and straight edge to construct a dilation as well. Copy the diagram below.

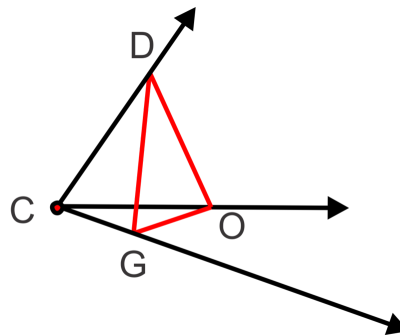

6. Set your compass to be CG and use this setting to mark off a point 3 times as far from C as G is. Label this point G' . Repeat this process for CO and CD to find O' and D' .
7. Connect G' , O' and D' to make $\triangle D'O'G'$. Find the ratios, $\frac{D'O'}{DO}$, $\frac{O'G'}{OG}$ and $\frac{G'D'}{GD}$.
8. What is the scale factor of this dilation?
9. Describe how you would dilate the figure by a scale factor of 4.
10. Describe how you would dilate the figure by a scale factor of $\frac{1}{2}$.
11. The scale factor between two shapes is 1.5. What is the ratio of their perimeters?
12. The scale factor between two shapes is 1.5. What is the ratio of their areas? *Hint: Draw an example and calculate what happens.*
13. Suppose you dilate a triangle with side lengths 3, 7, and 9 by a scale factor of 3. What are the side lengths of the image?

14. Suppose you dilate a rectangle with a width of 10 and a length of 12 by a scale factor of $\frac{1}{2}$. What are the dimensions of the image?
15. Find the areas of the rectangles in #14. What is the ratio of their areas?

7.12 Dilation in the Coordinate Plane

Here you'll learn how to draw dilated figures in the coordinate plane given starting coordinates and the scale factor. You'll also learn how to use dilated figures in the coordinate plane to find scale factors.

What if you were given the coordinates of a figure and were asked to dilate that figure by a scale factor of 2? How could you find the coordinates of the dilated figure? After completing this Concept, you'll be able to solve problems like this one.

Watch This



MEDIA

Click image to the left for more content.

CK-12 Foundation: Chapter7DilationintheCoordinatePlaneA

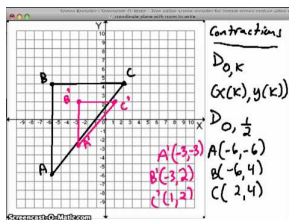

MEDIA

Click image to the left for more content.

Dilations

Guidance

A **dilation** makes a figure larger or smaller, but has the same shape as the original. In other words, the dilation is similar to the original. All dilations have a **center** and a **scale factor**. The center is the point of reference for the dilation (like the vanishing point in a perspective drawing) and scale factor tells us how much the figure stretches or shrinks. A scale factor is typically labeled k and is always greater than zero. Also, if the original figure is labeled $\triangle ABC$, for example, the dilation would be $\triangle A'B'C'$. The ' indicates that it is a copy. This tic mark is said "prime," so A' is read "A prime." A second dilation would be A'' , read "A double-prime."

If the dilated image is smaller than the original, then the scale factor is $0 < k < 1$.

If the dilated image is larger than the original, then the scale factor is $k > 1$.

To dilate something in the coordinate plane, multiply each coordinate by the scale factor. This is called **mapping**. For any dilation the mapping will be $(x, y) \rightarrow (kx, ky)$. In this Concept, the center of dilation will always be the origin, unless otherwise stated.

Example A

Determine the coordinates of $\triangle ABC$ and $\triangle A'B'C'$ and find the scale factor.

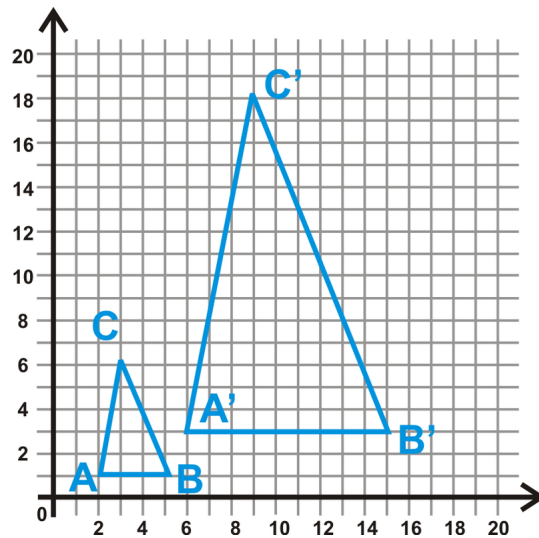

The coordinates of $\triangle ABC$ are $A(2, 1)$, $B(5, 1)$ and $C(3, 6)$. The coordinates of $\triangle A'B'C'$ are $A'(6, 3)$, $B'(15, 3)$ and $C'(9, 18)$. By looking at the corresponding coordinates, each is three times the original. That means $k = 3$.

Again, the center, original point, and dilated point are collinear. Therefore, you can draw a ray from the origin to C' , B' , and A' such that the rays pass through C , B , and A , respectively.

Example B

Show that dilations preserve shape by using the distance formula. Find the lengths of the sides of both triangles in Example A.

$$\begin{aligned} \triangle ABC \\ AB &= \sqrt{(2-5)^2 + (1-1)^2} = \sqrt{9} = 3 \end{aligned}$$

$$AC = \sqrt{(2-3)^2 + (1-6)^2} = \sqrt{26}$$

$$CB = \sqrt{(3-5)^2 + (6-1)^2} = \sqrt{29}$$

$$\begin{aligned} \triangle A'B'C' \\ A'B' &= \sqrt{(6-15)^2 + (3-3)^2} = \sqrt{81} = 9 \end{aligned}$$

$$A'C' = \sqrt{(6-9)^2 + (3-18)^2} = \sqrt{234} = 3\sqrt{26}$$

$$C'B' = \sqrt{(9-15)^2 + (18-3)^2} = \sqrt{261} = 3\sqrt{29}$$

From this, we also see that all the sides of $\triangle A'B'C'$ are three times larger than $\triangle ABC$.

Example C

Quadrilateral $EFGH$ has vertices $E(-4, -2)$, $F(1, 4)$, $G(6, 2)$ and $H(0, -4)$. Draw the dilation with a scale factor of 1.5.

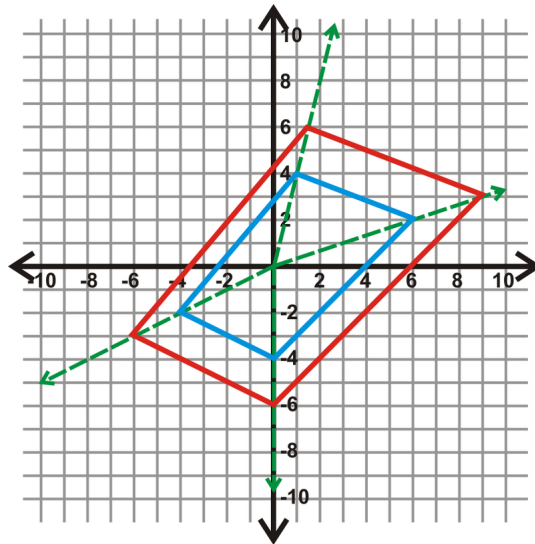

Remember that to dilate something in the coordinate plane, multiply each coordinate by the scale factor. For this dilation, the mapping will be $(x, y) \rightarrow (1.5x, 1.5y)$.

$$\text{amp}; E(-4, -2) \rightarrow (1.5(-4), 1.5(-2)) \rightarrow E'(-6, -3)$$

$$\text{amp}; F(1, 4) \rightarrow (1.5(1), 1.5(4)) \rightarrow F'(1.5, 6)$$

$$\text{amp}; G(6, 2) \rightarrow (1.5(6), 1.5(2)) \rightarrow G'(9, 3)$$

$$\text{amp}; H(0, -4) \rightarrow (1.5(0), 1.5(-4)) \rightarrow H'(0, -6)$$

Watch this video for help with the Examples above.



MEDIA

Click image to the left for more content.

[CK-12 Foundation: Chapter7DilationintheCoordinatePlaneB](#)

Vocabulary

In the graph above, the blue quadrilateral is the original and the red image is the dilation. A **dilation** is an enlargement or reduction of a figure that preserves shape but not size. All dilations are similar to the original figure. **Similar** figures are the same shape but not necessarily the same size. The **center of dilation** is the point of reference for the dilation and the **scale factor** for a dilation tells us how much the figure stretches or shrinks.

Guided Practice

Given A and the scale factor, determine the coordinates of the dilated point, A' . You may assume the center of dilation is the origin.

- $A(3, 9), k = \frac{2}{3}$

2. $A(-4, 6), k = 2$
3. $A(9, -13), k = \frac{1}{2}$

Answers

Remember that the mapping will be $(x, y) \rightarrow (kx, ky)$.

1. $A'(2, 6)$
2. $A'(-8, 12)$
3. $A'(4.5, -6.5)$

Practice

Given A and A' , find the scale factor. You may assume the center of dilation is the origin.

1. $A(8, 2), A'(12, 3)$
2. $A(-5, -9), A'(-45, -81)$
3. $A(22, -7), A'(11, -3.5)$

The origin is the center of dilation. Find the coordinates of the dilation of each figure, given the scale factor.

4. $A(2, 4), B(-3, 7), C(-1, -2); k = 3$
5. $A(12, 8), B(-4, -16), C(0, 10); k = \frac{3}{4}$

Multi-Step Problem Questions 6-12 build upon each other.

6. Plot $A(1, 2), B(12, 4), C(10, 10)$. Connect to form a triangle.
7. Make the origin the center of dilation. Draw 4 rays from the origin to each point from #6. Then, plot $A'(2, 4), B'(24, 8), C'(20, 20)$. What is the scale factor?
8. Use $k = 4$, to find $A''B''C''$. Plot these points.
9. What is the scale factor from $A'B'C'$ to $A''B''C''$?
10. Find (O is the origin):
 - a. OA
 - b. AA'
 - c. AA''
 - d. OA'
 - e. OA''
11. Find:
 - a. AB
 - b. $A'B'$
 - c. $A''B''$
12. Compare the ratios:
 - a. $OA : OA'$ and $AB : A'B'$
 - b. $OA : OA''$ and $AB : A''B''$

For questions 13-18, use quadrilateral $ABCD$ with $A(1, 5), B(2, 6), C(3, 3)$ and $D(1, 3)$ and its transformation $A'B'C'D'$ with $A'(-3, 1), B'(0, 4), C'(3, -5)$ and $D'(-3, -5)$.

13. Plot the two quadrilaterals in the coordinate plane.
14. Find the equation of $\overleftrightarrow{CC'}$.

15. Find the equation of $\overleftrightarrow{DD'}$.
16. Find the intersection of these two lines algebraically or graphically.
17. What is the significance of this point?
18. What is the scale factor of the dilation?

7.13 Self-Similarity

Here you'll learn what it means for an object to be self-similar and you'll be introduced to some common examples of self-similarity.

What if you were given an object, like a triangle or a snowflake, in which a part of it could be enlarged (or shrunk) to look like the whole object? What would each successive iteration of that object look like? After completing this Concept, you'll be able to use the idea of self-similarity to answer questions like this one.

Watch This



MEDIA

Click image to the left for more content.

CK-12 Foundation: Chapter7SelfSimilarityA

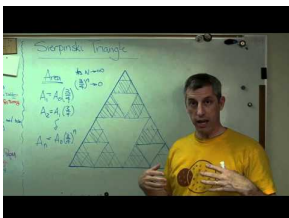

MEDIA

Click image to the left for more content.

Brain Waves: Sierpinski Triangle

Guidance

When one part of an object can be enlarged (or shrunk) to look like the whole object it is **self-similar**.

To explore self-similarity, we will go through some examples. Typically, each step of a process is called an *iteration*. The first level is called *Stage 0*.

Example A (Sierpinski Triangle)

The Sierpinski triangle iterates a triangle by connecting the midpoints of the sides and shading the central triangle (Stage 1). Repeat this process for the unshaded triangles in Stage 1 to get Stage 2.

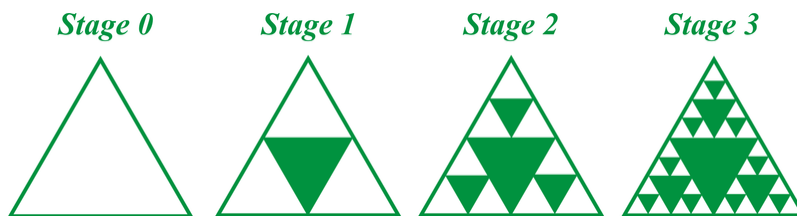

Example B (Fractals)

Like the Sierpinski triangle, a fractal is another self-similar object that is repeated at smaller scales. Below are the first three stages of the Koch snowflake.

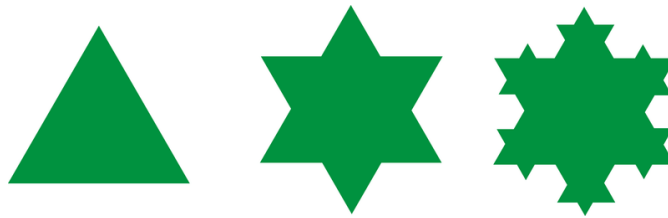
**Example C (The Cantor Set)**

The Cantor set is another example of a fractal. It consists of dividing a segment into thirds and then erasing the middle third.

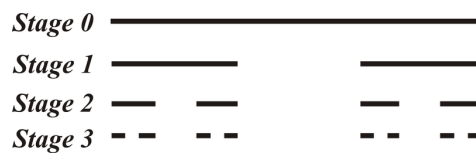

Watch this video for help with the Examples above.



MEDIA

Click image to the left for more content.

[CK-12 Foundation: Chapter7SelfSimilarityB](#)

Vocabulary

When one part of an object can be enlarged (or shrunk) to look like the whole object it is *self-similar*.

Guided Practice

1. Determine the number of edges and the perimeter of each snowflake shown in Example B. Assume that the length of one side of the original (stage 0) equilateral triangle is 1.
2. Determine the number of shaded and unshaded triangles in each stage of the Sierpinski triangle. Determine if there is a pattern.
3. Determine the number of segments in each stage of the Cantor Set. Is there a pattern?

Answers:

1.

TABLE 7.3:

| | <i>Stage 0</i> | <i>Stage 1</i> | <i>Stage 2</i> |
|------------------------|----------------|----------------|-------------------------------|
| <i>Number of Edges</i> | 3 | 12 | 48 |
| <i>Edge Length</i> | 1 | $\frac{1}{3}$ | $\frac{1}{9}$ |
| <i>Perimeter</i> | 3 | 4 | $\frac{48}{9} = \frac{16}{3}$ |

2.

TABLE 7.4:

| | <i>Stage 0</i> | <i>Stage 1</i> | <i>Stage 2</i> | <i>Stage 3</i> |
|-----------------|----------------|----------------|----------------|----------------|
| <i>Unshaded</i> | 1 | 3 | 9 | 27 |
| <i>Shaded</i> | 0 | 1 | 4 | 13 |

The number of unshaded triangles seems to be powers of 3 : $3^0, 3^1, 3^2, 3^3, \dots$. The number of shaded triangles is the sum the the number of shaded and unshaded triangles from the previous stage. For Example, the number of shaded triangles in Stage 4 would equal $27 + 13 = 40$.

3. Starting from Stage 0, the number of segments is 1, 2, 4, 8, 16, \dots . These are the powers of 2. $2^0, 2^1, 2^2, \dots$

Practice

1. Draw Stage 4 of the Cantor set.

Use the Cantor Set to fill in the table below.

TABLE 7.5:

| | <i>Number of Segments</i> | <i>Length of each Segment</i> | <i>Total Length of the Segments</i> |
|----------------|---------------------------|-------------------------------|-------------------------------------|
| <i>Stage 0</i> | 1 | 1 | 1 |
| <i>Stage 1</i> | 2 | $\frac{1}{3}$ | $\frac{2}{3}$ |
| <i>Stage 2</i> | 4 | $\frac{1}{9}$ | $\frac{4}{9}$ |
| <i>Stage 3</i> | (2) | (3) | (4) |
| <i>Stage 4</i> | (5) | (6) | (7) |
| <i>Stage 5</i> | (8) | (9) | (10) |

11. How many segments are in Stage n ?
12. What is the total length of the segments in Stage n ?
13. A variation on the Sierpinski triangle is the Sierpinski carpet, which splits a square into 9 equal squares, coloring the middle one only. Then, split the uncolored squares to get the next stage. Draw the first 3 stages of this fractal.
14. How many colored vs. uncolored squares are in each stage?
15. Use the internet to explore fractals further. Write a paragraph about another example of a fractal in music, art or another field that interests you.

Summary

This chapter is all about proportional relationships. It begins by introducing the concept of ratio and proportion and detailing properties of proportions. It then focuses on the geometric relationships of similar polygons. Applications of similar polygons and scale factors are covered. The AA, SSS, and SAS methods of determining similar triangles are presented and the Triangle Proportionality Theorem is explored. The chapter wraps up with the proportional relationships formed when parallel lines are cut by a transversal, similarity and dilated figures, and self-similarity.

Chapter Keywords

- Ratio
- Proportion
- Means
- Extremes
- Cross-Multiplication Theorem
- Similar Polygons
- Scale Factor
- AA Similarity Postulate
- Indirect Measurement
- SSS Similarity Theorem
- SAS Similarity Theorem
- Triangle Proportionality Theorem
- Triangle Proportionality Theorem Converse
- Transformation
- Rigid Transformation
- Non-rigid Transformation
- Dilation
- Self-Similar
- Fractal

Chapter Review

1. Solve the following proportions.

a. $\frac{x+3}{3} = \frac{10}{2}$

b. $\frac{8}{5} = \frac{2x-1}{x+3}$

2. The extended ratio of the angle in a triangle are 5:6:7. What is the measure of each angle?

3. Rewrite 15 quarts in terms of gallons.

Determine if the following pairs of polygons are similar. If it is two triangles, write *why* they are similar.

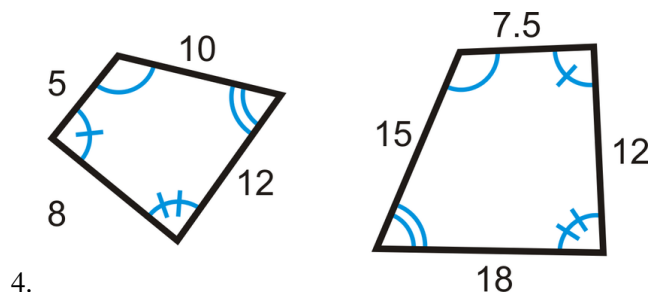

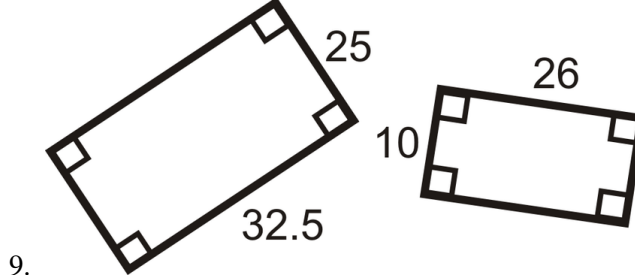
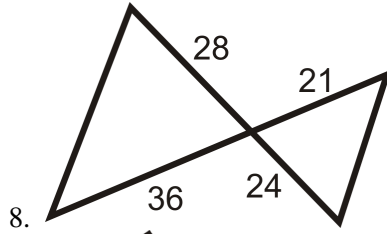
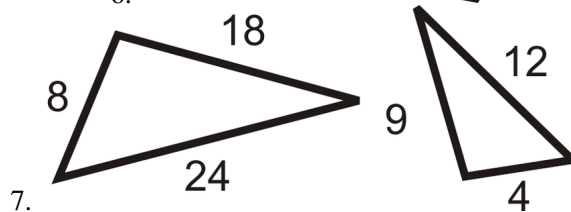
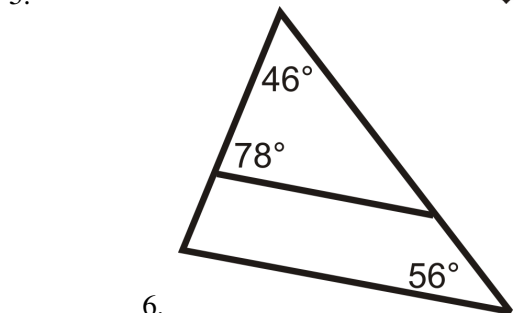
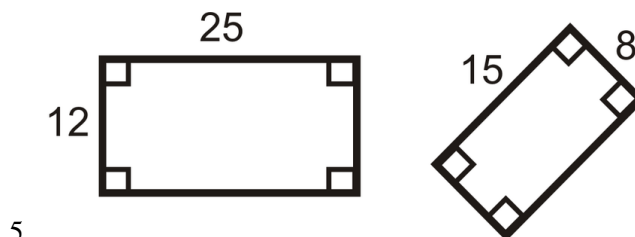

10. Draw a dilation of $A(7, 2)$, $B(4, 9)$, and $C(-1, 4)$ with $k = \frac{3}{2}$.

Algebra Connection Find the value of the missing variable(s).

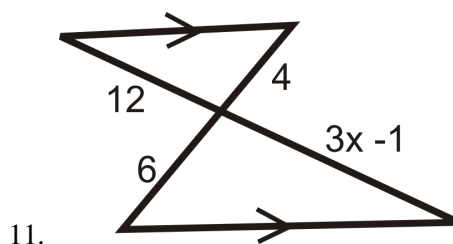

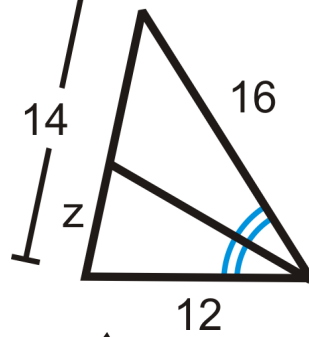
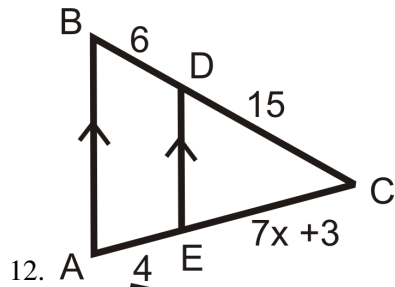

13.

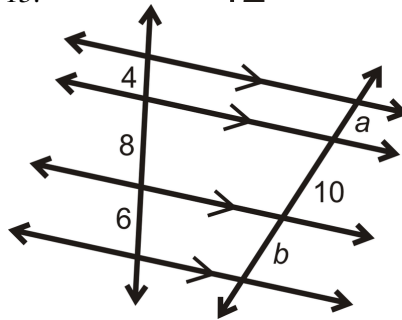

14.

Texas Instruments Resources

In the *CK-12 Texas Instruments Geometry FlexBook*, there are graphing calculator activities designed to supplement the objectives for some of the lessons in this chapter. See <http://www.ck12.org/flexr/chapter/9692>.

CHAPTER 8 Right Triangle Trigonometry

Chapter Outline

- 8.1 PYTHAGOREAN THEOREM AND PYTHAGOREAN TRIPLES
 - 8.2 APPLICATIONS OF THE PYTHAGOREAN THEOREM
 - 8.3 INSCRIBED SIMILAR TRIANGLES
 - 8.4 45-45-90 RIGHT TRIANGLES
 - 8.5 30-60-90 RIGHT TRIANGLES
 - 8.6 SINE, COSINE, TANGENT
 - 8.7 TRIGONOMETRIC RATIOS WITH A CALCULATOR
 - 8.8 TRIGONOMETRY WORD PROBLEMS
 - 8.9 INVERSE TRIGONOMETRIC RATIOS
 - 8.10 LAWS OF SINES AND COSINES
-

Introduction

Chapter 8 explores right triangles in far more depth than Chapters 4 and 5. Recall that a right triangle is a triangle with exactly one right angle. In this chapter, we will first prove the Pythagorean Theorem and its converse, followed by analyzing the sides of certain types of triangles. Then, we will introduce trigonometry, which starts with the tangent, sine and cosine ratios. Finally, we will extend sine and cosine to any triangle, through the Law of Sines and the Law of Cosines.

8.1 Pythagorean Theorem and Pythagorean Triples

Here you'll learn the Pythagorean Theorem and how to apply it in order to find missing sides of right triangles and determine whether or not triangles are right triangles.

What if a friend of yours wanted to design a rectangular building with one wall 65 ft long and the other wall 72 ft long? How can he ensure the walls are going to be perpendicular? After completing this Concept, you'll be able to apply the Pythagorean Theorem in order to solve problems like these.

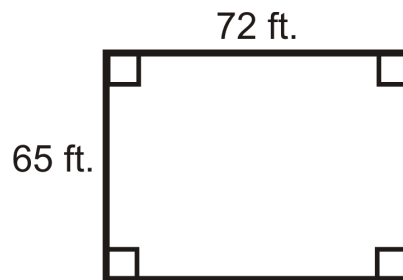

Watch This



MEDIA

Click image to the left for more content.

CK-12 Foundation: Chapter8ThePythagoreanTheoremandPythagoreanTriplesA

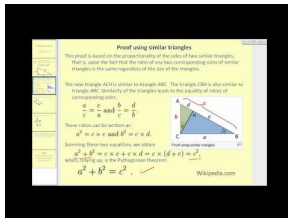

MEDIA

Click image to the left for more content.

James Sousa:PythagoreanTheorem

Guidance

The sides of a right triangle are called legs (the sides of the right angle) and the side opposite the right angle is the hypotenuse. For the Pythagorean Theorem, the legs are “ a ” and “ b ” and the hypotenuse is “ c ”.

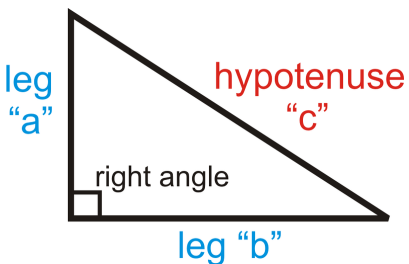

Pythagorean Theorem: Given a right triangle with legs of lengths a and b and a hypotenuse of length c , then $a^2 + b^2 = c^2$.

Pythagorean Theorem Converse: If the square of the longest side of a triangle is equal to the sum of the squares of the other two sides, then the triangle is a right triangle.

There are several proofs of the Pythagorean Theorem, shown below.

Investigation: Proof of the Pythagorean Theorem

Tools Needed: pencil, 2 pieces of graph paper, ruler, scissors, colored pencils (optional)

1. On the graph paper, draw a 3 in. square, a 4 in. square, a 5 in square and a right triangle with legs of 3 and 4 inches.
2. Cut out the triangle and square and arrange them like the picture on the right.

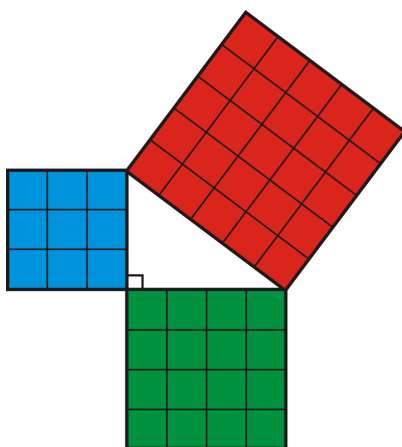

3. This theorem relies on area. Recall from a previous math class, that the area of a square is length times width. But, because the sides are the same you can rewrite this formula as $A_{square} = length \times width = side \times side = side^2$. So, the Pythagorean Theorem can be interpreted as $(square\ with\ side\ a)^2 + (square\ with\ side\ b)^2 = (square\ with\ side\ c)^2$. In this Investigation, the sides are 3, 4 and 5 inches. What is the area of each square?
4. Now, we know that $9 + 16 = 25$, or $3^2 + 4^2 = 5^2$. Cut the smaller squares to fit into the larger square, thus proving the areas are equal.

Another Proof of the Pythagorean Theorem

This proof is “more formal,” meaning that we will use letters, a , b , and c to represent the sides of the right triangle. In this particular proof, we will take four right triangles, with legs a and b and hypotenuse c and make the areas equal.

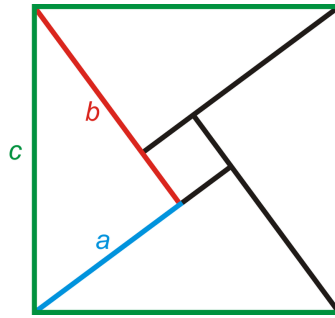

$$\begin{aligned}
 A_{\text{green square}} &= c^2 \\
 A_{\text{green square}} &= 4\left(\frac{1}{2}ab\right) + (b-a)^2 \\
 &= 2ab + b^2 - 2ab + a^2 \\
 &= b^2 + a^2
 \end{aligned}$$

↙ area of the four triangles
 ↙ area of small, central square
↙ FOIL (b-a)²

For two animated proofs, go to <http://www.mathsisfun.com/pythagoras.html> and scroll down to “And You Can Prove the Theorem Yourself.”

Pythagorean Triples

A **Pythagorean Triple** is a set of three whole numbers that makes the Pythagorean Theorem true. The most frequently used Pythagorean triple is 3, 4, 5, as in Investigation 8-1. Any multiple of a Pythagorean triple is also considered a triple because it would still be three whole numbers. Therefore, 6, 8, 10 and 9, 12, 15 are also sides of a right triangle. Other Pythagorean triples are:

3, 4, 5 5, 12, 13 7, 24, 25 8, 15, 17

There are infinitely many Pythagorean triples. To see if a set of numbers makes a triple, plug them into the Pythagorean Theorem.

Example A

Do 6, 7, and 8 make the sides of a right triangle?

Plug in the three numbers into the Pythagorean Theorem. **The largest length will always be the hypotenuse.** $6^2 + 7^2 = 36 + 49 = 85 \neq 8^2$. Therefore, these lengths do not make up the sides of a right triangle.

Example B

Find the length of the hypotenuse of the triangle below.

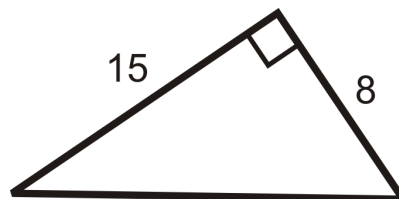

Let's use the Pythagorean Theorem. Set a and b equal to 8 and 15 and solve for c , the hypotenuse.

$$\begin{aligned} 8^2 + 15^2 &= c^2 \\ 64 + 225 &= c^2 \\ 289 &= c^2 && \text{Take the square root of both sides.} \\ 17 &= c \end{aligned}$$

When you take the square root of an equation, usually the answer is $+17$ or -17 . Because we are looking for length, we only use the positive answer. **Length is never negative.**

Example C

Is 20, 21, 29 a Pythagorean triple?

If $20^2 + 21^2$ is equal to 29^2 , then the set is a triple.

$$\begin{aligned} 20^2 + 21^2 &= 400 + 441 = 841 \\ 29^2 &= 841 \end{aligned}$$

Therefore, 20, 21, and 29 is a Pythagorean triple.

Example D

Determine if the triangle below is a right triangle.

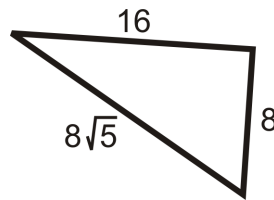

Check to see if the three lengths satisfy the Pythagorean Theorem. Let the longest sides represent c , in the equation.

$$\begin{aligned} a^2 + b^2 &= c^2 \\ 8^2 + 16^2 &= (8\sqrt{5})^2 \\ 64 + 256 &= 64 \cdot 5 \\ 320 &= 320 \end{aligned}$$

The triangle is a right triangle.

Watch this video for help with the Examples above.

MEDIA

Click image to the left for more content.

CK-12 Foundation: Chapter8PythagoreanTheoremandPythagoreanTriplesB

Concept Problem Revisited

To make the walls perpendicular, find the length of the diagonal.

$$\begin{aligned} 65^2 + 72^2 &= c^2 \\ 4225 + 5184 &= c^2 \\ 9409 &= c^2 \\ 97 &= c \end{aligned}$$

In order to make the building rectangular, both diagonals must be 97 feet.

Vocabulary

The two shorter sides of a right triangle (the sides that form the right angle) are the *legs* and the longer side (the side opposite the right angle) is the *hypotenuse*. The *Pythagorean Theorem* states that $a^2 + b^2 = c^2$, where the legs are “ a ” and “ b ” and the hypotenuse is “ c ”. A combination of three numbers that makes the Pythagorean Theorem true is called a *Pythagorean triple*.

Guided Practice

1. Find the missing side of the right triangle below.

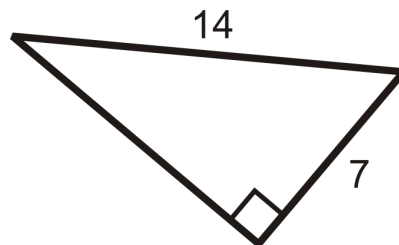

2. What is the diagonal of a rectangle with sides 10 and $16\sqrt{5}$?

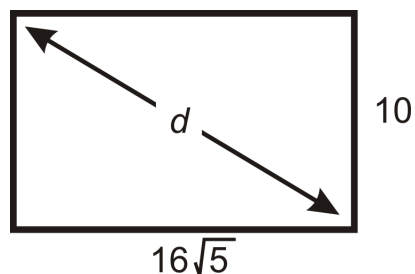

3. Determine if the triangle below is a right triangle.

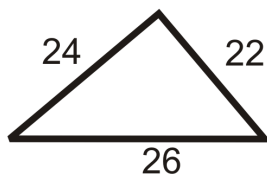

Answers:

1. Here, we are given the hypotenuse and a leg. Let's solve for b .

$$7^2 + b^2 = 14^2$$

$$49 + b^2 = 196$$

$$b^2 = 147$$

$$b = \sqrt{147} = \sqrt{7 \cdot 7 \cdot 3} = 7\sqrt{3}$$

2. For any square and rectangle, you can use the Pythagorean Theorem to find the length of a diagonal. Plug in the sides to find d .

$$10^2 + (16\sqrt{5})^2 = d^2$$

$$100 + 1280 = d^2$$

$$1380 = d^2$$

$$d = \sqrt{1380} = 2\sqrt{345}$$

3. Check to see if the three lengths satisfy the Pythagorean Theorem. Let the longest sides represent c , in the equation.

$$a^2 + b^2 = c^2$$

$$22^2 + 24^2 = 26^2$$

$$484 + 576 = 676$$

$$1060 \neq 676$$

The triangle is not a right triangle.

Practice

Find the length of the missing side. Simplify all radicals.

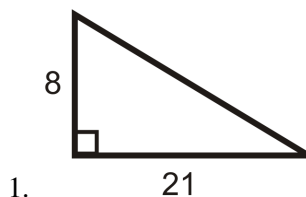

1.

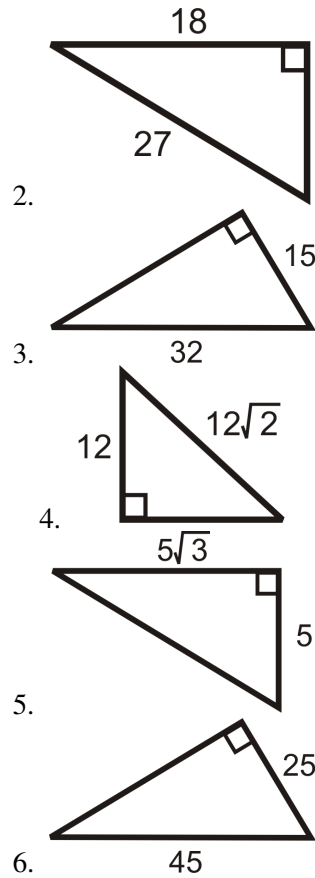

7. If the legs of a right triangle are 10 and 24, then the hypotenuse is _____.
8. If the sides of a rectangle are 12 and 15, then the diagonal is _____.
9. If the legs of a right triangle are x and y , then the hypotenuse is _____.
10. If the sides of a square are 9, then the diagonal is _____.

Determine if the following sets of numbers are Pythagorean Triples.

11. 12, 35, 37
 12. 9, 17, 18
 13. 10, 15, 21
 14. 11, 60, 61
 15. 15, 20, 25
 16. 18, 73, 75

Pythagorean Theorem Proofs

The first proof below is similar to the one done earlier in this Concept. Use the picture below to answer the following questions.

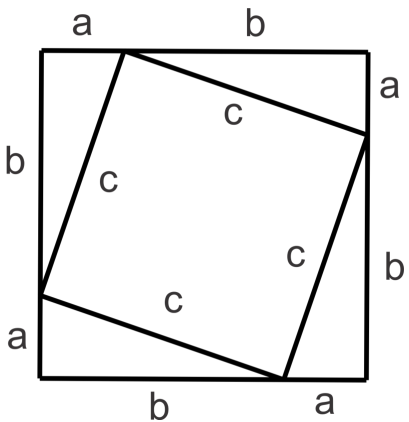

17. Find the area of the square with sides $(a + b)$.
18. Find the sum of the areas of the square with sides c and the right triangles with legs a and b .
19. The areas found in the previous two problems should be the same value. Set the expressions equal to each other and simplify to get the Pythagorean Theorem.

Major General James A. Garfield (and former President of the U.S) is credited with deriving this next proof of the Pythagorean Theorem using a trapezoid.

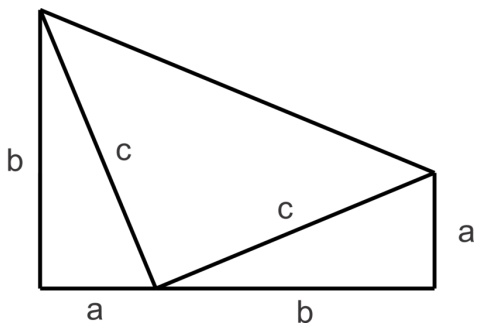

20. Find the area of the trapezoid using the trapezoid area formula: $A = \frac{1}{2}(b_1 + b_2)h$
21. Find the sum of the areas of the three right triangles in the diagram.
22. The areas found in the previous two problems should be the same value. Set the expressions equal to each other and simplify to get the Pythagorean Theorem.

8.2 Applications of the Pythagorean Theorem

Here you'll learn several applications of the Pythagorean Theorem.

What if you had a 52" High Definition Television (52" being the length of the diagonal of the rectangular viewing area)? High Definition Televisions (HDTVs) have sides in the ratio of 16:9. What is the length and width of a 52" HDTV? What is the length and width of an HDTV with a y " long diagonal?

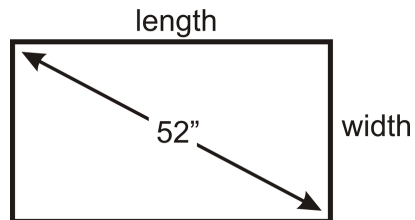

Watch This



MEDIA

Click image to the left for more content.

[CK-12 Foundation: Chapter8ApplicationsofthePythagoreanTheoremA](#)

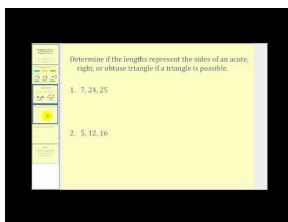

MEDIA

Click image to the left for more content.

[James Sousa:PythagoreanTheoremAndItsConverse](#)

Guidance

There are many different applications of the Pythagorean Theorem. Three applications are explored below.

Find the Height of an Isosceles Triangle

One way to use The Pythagorean Theorem is to identify the heights in isosceles triangles so you can calculate the area. The area of a triangle is $\frac{1}{2}bh$, where b is the base and h is the height (or altitude).

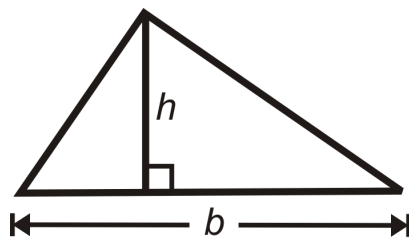

If you are given the base and the sides of an isosceles triangle, you can use the Pythagorean Theorem to calculate the height.

Prove the Distance Formula

Another application of the Pythagorean Theorem is the Distance Formula.

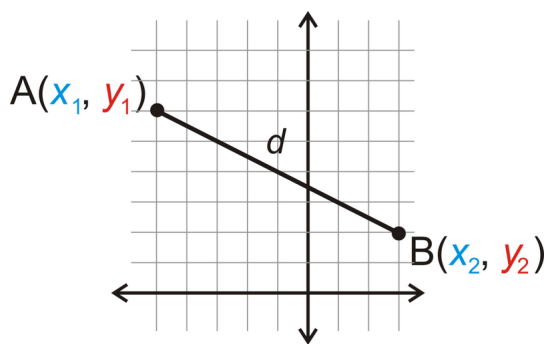

First, draw the vertical and horizontal lengths to make a right triangle. Then, use the differences to find these distances.

Now that we have a right triangle, we can use the Pythagorean Theorem to find d .

A coordinate plane with a grid. Two points are plotted: $A(x_1, y_1)$ and $B(x_2, y_2)$. A line segment connects the two points, and its length is labeled d . A right triangle is formed by drawing a horizontal line segment from A to the right and a vertical line segment from that point down to B . The horizontal leg is labeled $x_1 - x_2$ and the vertical leg is labeled $y_1 - y_2$. A right-angle symbol is shown at the vertex of the horizontal and vertical legs. A blue arrow points from the equation below to the horizontal leg, and a red arrow points from the equation below to the vertical leg.

$$d^2 = (x_1 - x_2)^2 + (y_1 - y_2)^2$$

$$d = \sqrt{(x_1 - x_2)^2 + (y_1 - y_2)^2}$$

Distance Formula: The distance $A(x_1, y_1)$ and $B(x_2, y_2)$ is $d = \sqrt{(x_1 - x_2)^2 + (y_1 - y_2)^2}$.

Determine if a Triangle is Acute, Obtuse, or Right

We can extend the converse of the Pythagorean Theorem to determine if a triangle has an obtuse angle or is acute. We know that if the sum of the squares of the two smaller sides equals the square of the larger side, then the triangle is right. We can also interpret the outcome if the sum of the squares of the smaller sides does not equal the square of the third.

Theorem: (1) If the sum of the squares of the two shorter sides in a right triangle is *greater* than the square of the longest side, then the triangle is *acute*. (2) If the sum of the squares of the two shorter sides in a right triangle is *less* than the square of the longest side, then the triangle is *obtuse*.

In other words: The sides of a triangle are a, b , and c and $c > b$ and $c > a$.

If $a^2 + b^2 > c^2$, then the triangle is acute.

If $a^2 + b^2 = c^2$, then the triangle is right.

If $a^2 + b^2 < c^2$, then the triangle is obtuse.

Proof of Part 1:

Given: In $\triangle ABC$, $a^2 + b^2 > c^2$, where c is the longest side.

In $\triangle LMN$, $\angle N$ is a right angle.

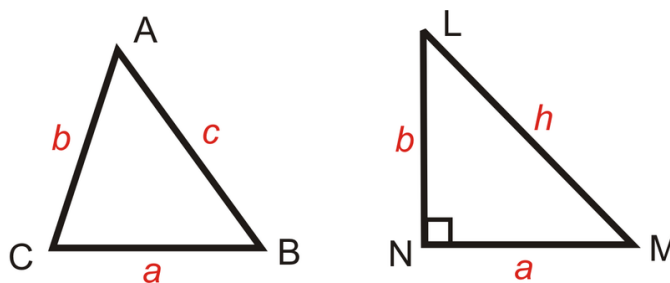

Prove: $\triangle ABC$ is an acute triangle. (all angles are less than 90°)

TABLE 8.1:

| Statement | Reason |
|--|---|
| 1. In $\triangle ABC$, $a^2 + b^2 > c^2$, and c is the longest side. In $\triangle LMN$, $\angle N$ is a right angle. | Given |
| 2. $a^2 + b^2 = h^2$ | Pythagorean Theorem |
| 3. $c^2 < h^2$ | Transitive PoE |
| 4. $c < h$ | Take the square root of both sides |
| 5. $\angle C$ is the largest angle in $\triangle ABC$. | The largest angle is opposite the longest side. |
| 6. $m\angle N = 90^\circ$ | Definition of a right angle |
| 7. $m\angle C < m\angle N$ | SSS Inequality Theorem |
| 8. $m\angle C < 90^\circ$ | Transitive PoE |
| 9. $\angle C$ is an acute angle. | Definition of an acute angle |
| 10. $\triangle ABC$ is an acute triangle. | If the largest angle is less than 90° , then all the angles are less than 90° . |

Example A

What is the area of the isosceles triangle?

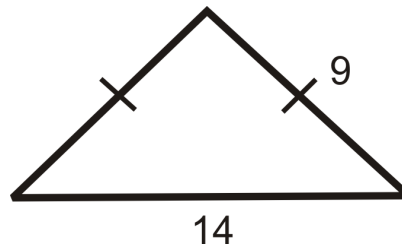

First, draw the altitude from the vertex between the congruent sides, which will bisect the base (Isosceles Triangle Theorem). Then, find the length of the altitude using the Pythagorean Theorem.

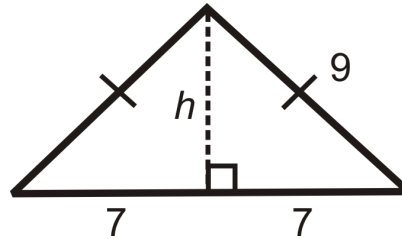

$$\begin{aligned}7^2 + h^2 &= 9^2 \\49 + h^2 &= 81 \\h^2 &= 32 \\h &= \sqrt{32} = 4\sqrt{2}\end{aligned}$$

Now, use h and b in the formula for the area of a triangle.

$$A = \frac{1}{2}bh = \frac{1}{2}(14)(4\sqrt{2}) = 28\sqrt{2} \text{ units}^2$$

Example B

Find the distance between $(1, 5)$ and $(5, 2)$.

Make $A(1, 5)$ and $B(5, 2)$. Plug into the distance formula.

$$\begin{aligned}d &= \sqrt{(1-5)^2 + (5-2)^2} \\&= \sqrt{(-4)^2 + (3)^2} \\&= \sqrt{16+9} = \sqrt{25} = 5\end{aligned}$$

You might recall that the distance formula was presented as $d = \sqrt{(x_2 - x_1)^2 + (y_2 - y_1)^2}$, with the first and second points switched. It does not matter which point is first as long as x and y are both first in each parenthesis. In Example 7, we could have switched A and B and would still get the same answer.

$$\begin{aligned}
 d &= \sqrt{(5-1)^2 + (2-5)^2} \\
 &= \sqrt{(4)^2 + (-3)^2} \\
 &= \sqrt{16+9} = \sqrt{25} = 5
 \end{aligned}$$

Also, just like the lengths of the sides of a triangle, distances are always positive.

Example C

Determine if the following triangles are acute, right or obtuse.

a)

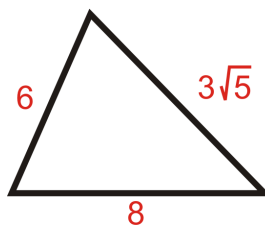

b)

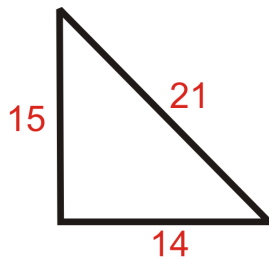

Set the shorter sides in each triangle equal to a and b and the longest side equal to c .

a)

$$\begin{aligned}
 6^2 + (3\sqrt{5})^2 &? 8^2 \\
 36 + 45 &? 64 \\
 81 &> 64
 \end{aligned}$$

The triangle is acute.

b)

$$\begin{aligned}
 15^2 + 14^2 &? 21^2 \\
 225 + 196 &? 441 \\
 421 &< 441
 \end{aligned}$$

The triangle is obtuse.

Watch this video for help with the Examples above.



MEDIA

Click image to the left for more content.

CK-12 Foundation: Chapter8ApplicationsofthePythagoreanTheoremB

Concept Problem Revisited

To find the length and width of a 52" HDTV, plug in the ratios and 52 into the Pythagorean Theorem. We know that the sides are going to be a multiple of 16 and 9, which we will call n .

$$\begin{aligned}(16n)^2 + (9n)^2 &= 52^2 \\ 256n^2 + 81n^2 &= 2704 \\ 337n^2 &= 2704 \\ n^2 &= 8.024 \\ n &= 2.83\end{aligned}$$

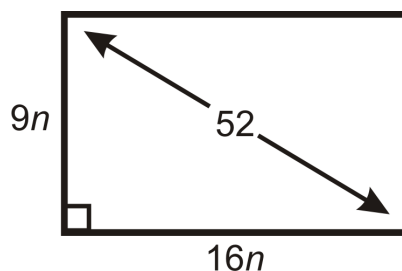

Therefore, the dimensions of the TV are $16(2.83'')$ by $9(2.83'')$, or $45.3''$ by $25.5''$. If the diagonal is y'' long, it would be $n\sqrt{337}''$ long. The extended ratio is $9 : 16 : \sqrt{337}$.

Vocabulary

The two shorter sides of a right triangle (the sides that form the right angle) are the **legs** and the longer side (the side opposite the right angle) is the **hypotenuse**. The **Pythagorean Theorem** states that $a^2 + b^2 = c^2$, where the legs are " a " and " b " and the hypotenuse is " c ". **Acute** triangles are triangles where all angles are less than 90° . **Right** triangles are triangles with one 90° angle. **Obtuse** triangles are triangles with one angle that is greater than 90° .

Guided Practice

- Graph $A(-4, 1)$, $B(3, 8)$, and $C(9, 6)$. Determine if $\triangle ABC$ is acute, obtuse, or right.
- Do the lengths 7, 8, 9 make a triangle that is right, acute, or obtuse? 3. Do the lengths 14, 48, 50 make a triangle that is right, acute, or obtuse?

Answers:

- This looks like an obtuse triangle, but we need proof to draw the correct conclusion. Use the distance formula to find the length of each side.

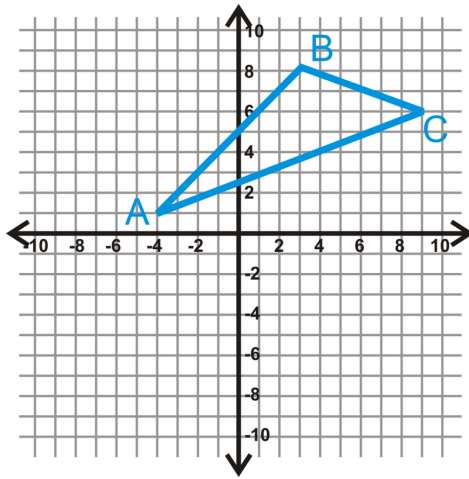

$$AB = \sqrt{(-4 - 3)^2 + (1 - 8)^2} = \sqrt{49 + 49} = \sqrt{98} = 7\sqrt{2}$$

$$BC = \sqrt{(3 - 9)^2 + (8 - 6)^2} = \sqrt{36 + 4} = \sqrt{40} = 2\sqrt{10}$$

$$AC = \sqrt{(-4 - 9)^2 + (1 - 6)^2} = \sqrt{169 + 25} = \sqrt{194}$$

Now, let's plug these lengths into the Pythagorean Theorem.

$$\begin{aligned} (\sqrt{98})^2 + (\sqrt{40})^2 &? (\sqrt{194})^2 \\ 98 + 40 &? 194 \\ 138 &< 194 \end{aligned}$$

$\triangle ABC$ is an obtuse triangle.

2. Acute because $7^2 + 8^2 > 9^2$.

3. Right because $14^2 + 48^2 = 50^2$

Practice

Find the area of each triangle below. Round your answers to the nearest tenth.

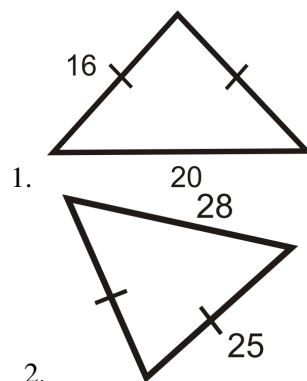

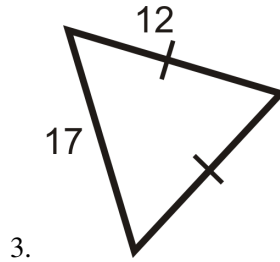

Find the length between each pair of points.

4. (-1, 6) and (7, 2)
5. (10, -3) and (-12, -6)
6. (1, 3) and (-8, 16)
7. What are the length and width of a 42" HDTV? Round your answer to the nearest tenth.
8. Standard definition TVs have a length and width ratio of 4:3. What are the length and width of a 42" Standard definition TV? Round your answer to the nearest tenth.
9. **Challenge** An equilateral triangle is an isosceles triangle. If all the sides of an equilateral triangle are s , find the area, using the technique learned in this section. Leave your answer in simplest radical form.

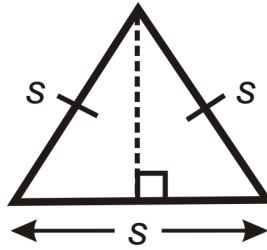

10. Find the area of an equilateral triangle with sides of length 8.
11. The two *shorter* sides of a triangle are 9 and 12.
 - a. What would be the length of the third side to make the triangle a right triangle?
 - b. What is a possible length of the third side to make the triangle acute?
 - c. What is a possible length of the third side to make the triangle obtuse?
12. The two *longer* sides of a triangle are 24 and 25.
 - a. What would be the length of the third side to make the triangle a right triangle?
 - b. What is a possible length of the third side to make the triangle acute?
 - c. What is a possible length of the third side to make the triangle obtuse?
13. The lengths of the sides of a triangle are $8x$, $15x$, and $17x$. Determine if the triangle is acute, right, or obtuse.

Determine if the following triangles are acute, right or obtuse.

14. 5, 12, 15
15. 13, 84, 85
16. 20, 20, 24
17. 35, 40, 51
18. 39, 80, 89
19. 20, 21, 38
20. 48, 55, 76

Graph each set of points and determine if $\triangle ABC$ is acute, right, or obtuse.

21. $A(3, -5), B(-5, -8), C(-2, 7)$
22. $A(5, 3), B(2, -7), C(-1, 5)$
23. **Writing** Explain the two different ways you can show that a triangle in the coordinate plane is a right triangle.

8.3 Inscribed Similar Triangles

Here you'll learn how inscribed right triangles are similar and how to apply this in order to solve for missing information.

What if you were told that, in California, the average home price increased 21.3% in 2004 and another 16.0% in 2005? What is the average rate of increase for these two years? After completing this Concept, you will be able to use the geometric mean to help solve this problem.

Watch This



MEDIA

Click image to the left for more content.

[CK-12 Foundation: Chapter8InscribedSimilarTrianglesA](#)

Learn more about similar triangles in right triangles by watching the second part of this video.

Guidance

If two objects are similar, corresponding angles are congruent and their sides are proportional in length. Let's look at a right triangle, with an altitude drawn from the right angle. There are three right triangles in this picture, $\triangle ADB$, $\triangle CDA$, and $\triangle CAB$. Both of the two smaller triangles are similar to the larger triangle because they each share an angle with $\triangle ADB$. That means all three triangles are similar to each other.

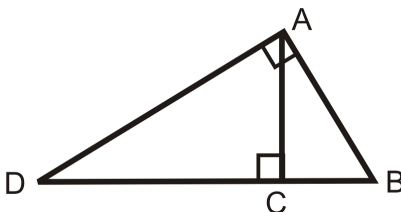

Inscribed Triangle Theorem: If an altitude is drawn from the right angle of any right triangle, then the two triangles formed are similar to the original triangle and all three triangles are similar to each other.

You are probably familiar with the arithmetic mean, which *divides the sum* of n numbers by n . This is commonly used to determine the average test score for a group of students. The geometric mean is a different sort of average, which takes the *n^{th} root of the product* of n numbers. In this text, we will primarily compare two numbers, so we would be taking the square root of the product of two numbers. This mean is commonly used with rates of increase or decrease.

Geometric Mean: The geometric mean of two positive numbers a and b is the number x , such that $\frac{a}{x} = \frac{x}{b}$ or $x^2 = ab$ and $x = \sqrt{ab}$.

Geometric Mean Theorem #1: In a right triangle, the altitude drawn from the right angle to the hypotenuse divides the hypotenuse into two segments. The length of the altitude is the geometric mean of these two segments. In other words, $\frac{BC}{AC} = \frac{AC}{DC}$.

Geometric Mean Theorem #2: In a right triangle, the altitude drawn from the right angle to the hypotenuse divides the hypotenuse into two segments. The length of each leg of the right triangle is the geometric mean of the lengths of the hypotenuse and the segment of the hypotenuse that is adjacent to the leg. In other words, $\frac{BC}{AB} = \frac{AB}{DB}$ and $\frac{DC}{AD} = \frac{AD}{DB}$.

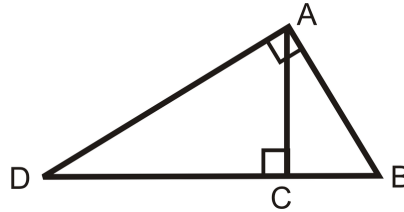

Both of these theorems are proved using similar triangles.

Example A

Write the similarity statement for the triangles below.

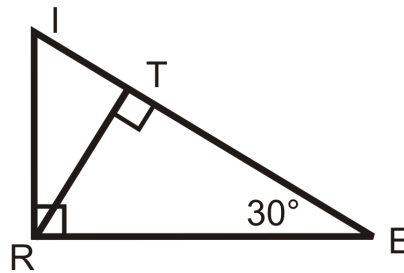

If $m\angle E = 30^\circ$, then $m\angle I = 60^\circ$ and $m\angle TRE = 60^\circ$. $m\angle IRT = 30^\circ$ because it is complementary to $\angle TRE$. Line up the congruent angles in the similarity statement. $\triangle IRE \sim \triangle ITR \sim \triangle RTE$

We can also use the side proportions to find the length of the altitude.

Example B

Find the value of x .

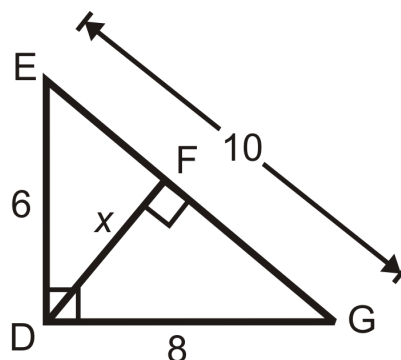

First, let's separate the triangles to find the corresponding sides.

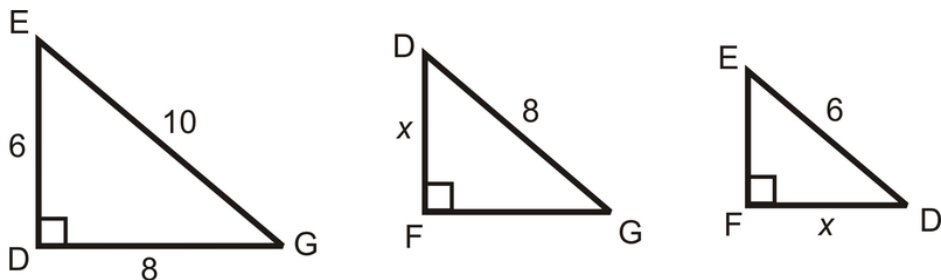

Now we can set up a proportion.

$$\begin{aligned} \frac{\text{shorter leg in } \triangle EDG}{\text{shorter leg in } \triangle DFG} &= \frac{\text{hypotenuse in } \triangle EDG}{\text{hypotenuse in } \triangle DFG} \\ \frac{6}{x} &= \frac{10}{8} \\ 48 &= 10x \\ 4.8 &= x \end{aligned}$$

Example C

Find the geometric mean of 24 and 36.

$$x = \sqrt{24 \cdot 36} = \sqrt{12 \cdot 2 \cdot 12 \cdot 3} = 12\sqrt{6}$$

Example D

Find the value of x .

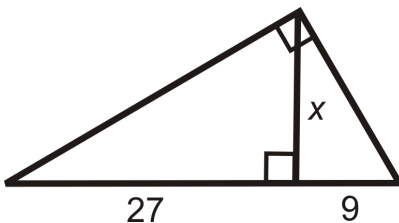

Using similar triangles, we have the proportion

$$\begin{aligned} \frac{\text{shortest leg of smallest } \triangle}{\text{shortest leg of middle } \triangle} &= \frac{\text{longer leg of smallest } \triangle}{\text{longer leg of middle } \triangle} \\ \frac{9}{x} &= \frac{x}{27} \\ x^2 &= 243 \\ x &= \sqrt{243} = 9\sqrt{3} \end{aligned}$$

Watch this video for help with the Examples above.



MEDIA

Click image to the left for more content.

CK-12 Foundation: Chapter8InscribedSimilarTrianglesB

Concept Problem Revisited

The average rate of increase can be found by using the geometric mean.

$$x = \sqrt{0.213 \cdot 0.16} = 0.1846$$

Over the two year period, housing prices increased 18.46%.

Vocabulary

If two objects are *similar*, they are the same shape but not necessarily the same size. The corresponding angles of similar polygons are congruent and their sides are proportional in length. The *geometric mean* of two positive numbers a and b is the number x , such that $\frac{a}{x} = \frac{x}{b}$ or $x^2 = ab$ and $x = \sqrt{ab}$.

Guided Practice

1. Find the value of x .

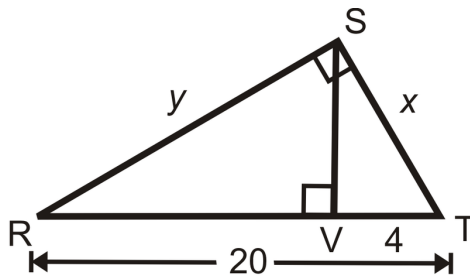

2. Find the value of y in $\triangle RST$ above.
3. Find the geometric mean of 18 and 54.
4. Find the value of x and y .

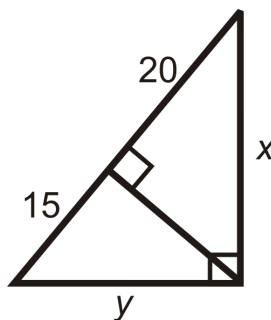

Answers:

1. Let's set up a proportion.

$$\begin{aligned}\frac{\text{shorter leg in } \triangle SVT}{\text{shorter leg in } \triangle RST} &= \frac{\text{hypotenuse in } \triangle SVT}{\text{hypotenuse in } \triangle RST} \\ \frac{4}{x} &= \frac{x}{20} \\ x^2 &= 80 \\ x &= \sqrt{80} = 4\sqrt{5}\end{aligned}$$

2. Use the Pythagorean Theorem.

$$\begin{aligned}y^2 + (4\sqrt{5})^2 &= 20^2 \\ y^2 + 80 &= 400 \\ y^2 &= 320 \\ y &= \sqrt{320} = 8\sqrt{5}\end{aligned}$$

$$3. x = \sqrt{18 \cdot 54} = \sqrt{18 \cdot 18 \cdot 3} = 18\sqrt{3}$$

4. Use the Geometric Mean Theorems to solve for x and y .

$$\begin{array}{ll}\frac{20}{x} = \frac{x}{35} & \frac{15}{y} = \frac{y}{35} \\ x^2 = 20 \cdot 35 & y^2 = 15 \cdot 35 \\ x = \sqrt{20 \cdot 35} & y = \sqrt{15 \cdot 35} \\ x = 10\sqrt{7} & y = 5\sqrt{21}\end{array}$$

You could also use the Pythagorean Theorem to solve for y , once x has been solved for.

$$\begin{aligned}(10\sqrt{7})^2 + y^2 &= 35^2 \\ 700 + y^2 &= 1225 \\ y &= \sqrt{525} = 5\sqrt{21}\end{aligned}$$

Either method is acceptable.

Practice

Use the diagram to answer questions 1-4.

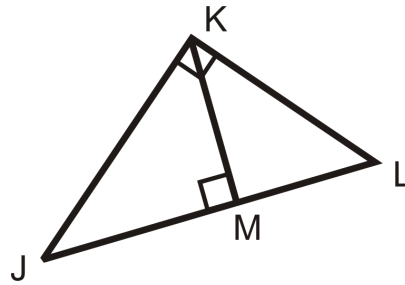

1. Write the similarity statement for the three triangles in the diagram.
2. If $JM = 12$ and $ML = 9$, find KM .
3. Find JK .
4. Find KL .

Find the geometric mean between the following two numbers. Simplify all radicals.

5. 16 and 32
6. 45 and 35
7. 10 and 14
8. 28 and 42
9. 40 and 100
10. 51 and 8

Find the length of the missing variable(s). Simplify all radicals.

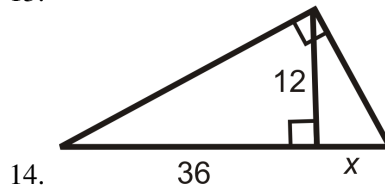
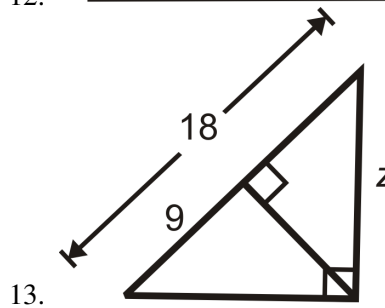
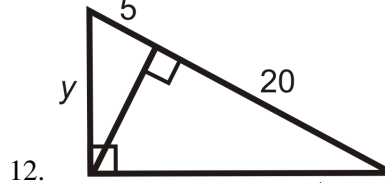
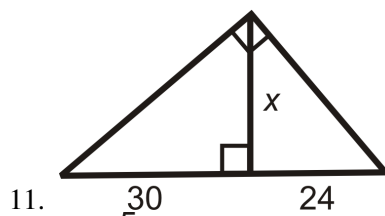

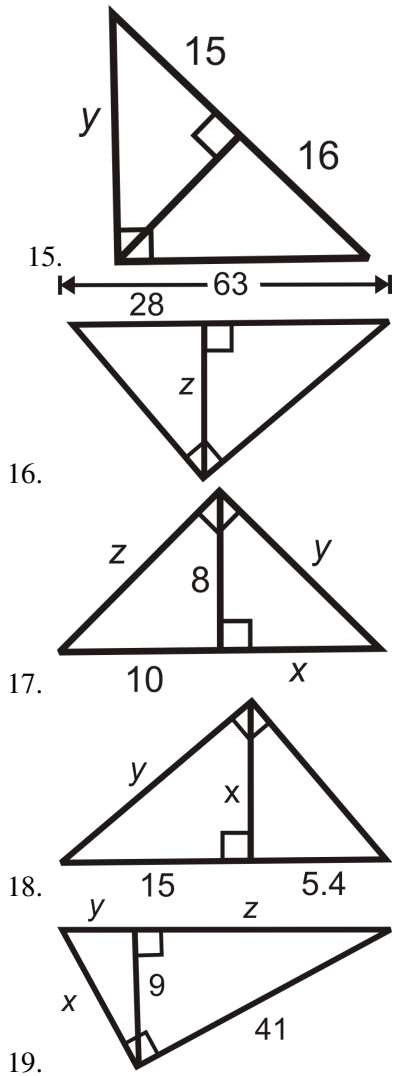

20. Last year Poorva’s rent increased by 5% and this year her landlord wanted to raise her rent by 7.5%. What is the average rate at which her landlord has raised her rent over the course of these two years?
21. Mrs. Smith teaches AP Calculus. Between the first and second years she taught the course her students’ average score improved by 12%. Between the second and third years, the scores increased by 9%. What is the average rate of improvement in her students’ scores?
22. According to the US Census Bureau, <http://www.census.gov/ipc/www/idb/country.php> the rate of growth of the US population was 0.8% and in 2009 it was 1.0%. What was the average rate of population growth during that time period?

Algebra Connection A geometric sequence is a sequence of numbers in which each successive term is determined by multiplying the previous term by the common ratio. An example is the sequence 1, 3, 9, 27, ... Here each term is multiplied by 3 to get the next term in the sequence. Another way to look at this sequence is to compare the ratios of the consecutive terms.

23. Find the ratio of the 2^{nd} to 1^{st} terms and the ratio of the 3^{rd} to 2^{nd} terms. What do you notice? Is this true for the next set (4^{th} to 3^{rd} terms)?
24. Given the sequence 4, 8, 16, ..., if we equate the ratios of the consecutive terms we get: $\frac{8}{4} = \frac{16}{8}$. This means that 8 is the _____ of 4 and 16. We can generalize this to say that every term in a geometric sequence is the _____ of the previous and subsequent terms.

Use what you discovered in problem 24 to find the middle term in the following geometric sequences.

25. 5, _____, 20

26. 4, _____, 100

27. 2, _____, $\frac{1}{2}$

8.4 45-45-90 Right Triangles

Here you'll learn that the sides of a 45-45-90 right triangle are in the ratio $x : x : x\sqrt{2}$.

What if you were given an isosceles right triangle and the length of one of its sides? How could you figure out the lengths of its other sides? After completing this Concept, you'll be able to use the 45-45-90 Theorem to solve problems like this one.

Watch This



MEDIA

Click image to the left for more content.

CK-12 Foundation: Chapter8454590RightTrianglesA

Watch the second half of this video.

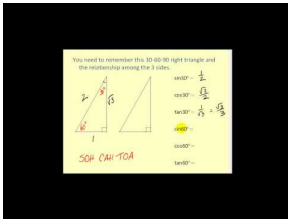

MEDIA

Click image to the left for more content.

James Sousa:Trigonometric Function Values of Special Angles

Watch the second half of this video.

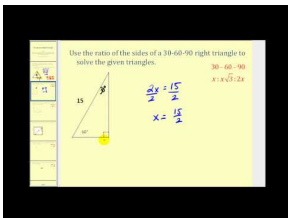

MEDIA

Click image to the left for more content.

James Sousa:SolvingSpecialRight Triangles

Guidance

There are two types of special right triangles, based on their angle measures. The first is an isosceles right triangle. Here, the legs are congruent and, by the Base Angles Theorem, the base angles will also be congruent. Therefore, the angle measures will be 90° , 45° , and 45° . You will also hear an isosceles right triangle called a 45-45-90 triangle. Because the three angles are always the same, all isosceles right triangles are similar.

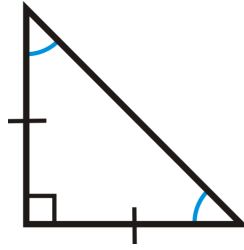

Investigation: Properties of an Isosceles Right Triangle

Tools Needed: Pencil, paper, compass, ruler, protractor

1. Construct an isosceles right triangle with 2 in legs. Use the SAS construction that you learned in Chapter 4.

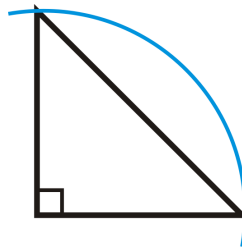

2. Find the measure of the hypotenuse. What is it? Simplify the radical.
3. Now, let's say the legs are of length x and the hypotenuse is h . Use the Pythagorean Theorem to find the hypotenuse. What is it? How is this similar to your answer in #2?

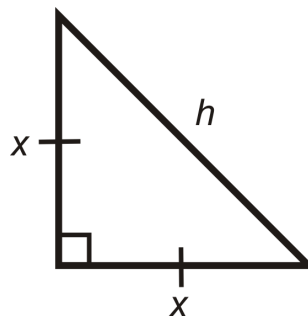

$$x^2 + x^2 = h^2$$

$$2x^2 = h^2$$

$$x\sqrt{2} = h$$

45-45-90 Corollary: If a triangle is an isosceles right triangle, then its sides are in the extended ratio $x : x : x\sqrt{2}$.

Step 3 in the above investigation proves the 45-45-90 Triangle Theorem. So, anytime you have a right triangle with congruent legs or congruent angles, then the sides will always be in the ratio $x : x : x\sqrt{2}$. The hypotenuse is always $x\sqrt{2}$ because that is the longest length. This is a specific case of the Pythagorean Theorem, so it will still work, if for some reason you forget this corollary.

Example A

Find the length of the missing sides.

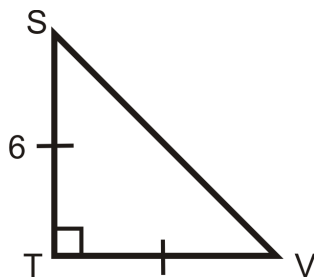

Use the $x : x : x\sqrt{2}$ ratio.

$TV = 6$ because it is equal to ST . So, $SV = 6\sqrt{2}$.

Example B

Find the length of x .

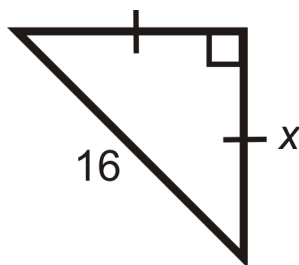

Again, use the $x : x : x\sqrt{2}$ ratio. We are given the hypotenuse, so we need to solve for x in the ratio.

$$\begin{aligned} x\sqrt{2} &= 16 \\ x &= \frac{16}{\sqrt{2}} \cdot \frac{\sqrt{2}}{\sqrt{2}} \\ x &= \frac{16\sqrt{2}}{2} \\ x &= 8\sqrt{2} \end{aligned}$$

Note that we *rationalized the denominator*. Whenever there is a radical in the denominator of a fraction, multiply the top and bottom by that radical. This will cancel out the radical from the denominator and reduce the fraction.

Example C

A square has a diagonal with length 10, what are the lengths of the sides?

Draw a picture.

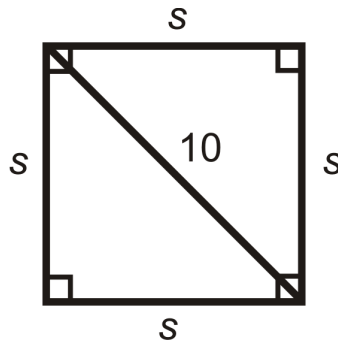

We know half of a square is a 45-45-90 triangle, so $10 = s\sqrt{2}$.

$$s\sqrt{2} = 10$$

$$s = \frac{10}{\sqrt{2}} \cdot \frac{\sqrt{2}}{\sqrt{2}} = \frac{10\sqrt{2}}{2} = 5\sqrt{2}$$

Watch this video for help with the Examples above.



MEDIA

Click image to the left for more content.

[CK-12 Foundation: Chapter8454590RightTrianglesB](#)

Vocabulary

A *right triangle* is a triangle with a 90° angle. A *45-45-90 triangle* is a right triangle with angle measures of 45° , 45° , and 90° .

Guided Practice

- Find the length of the missing sides.

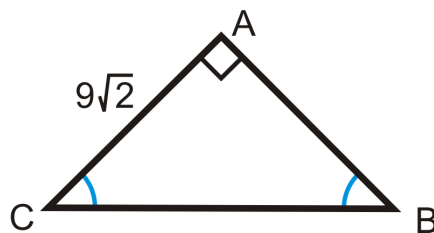

- Find the length of x .

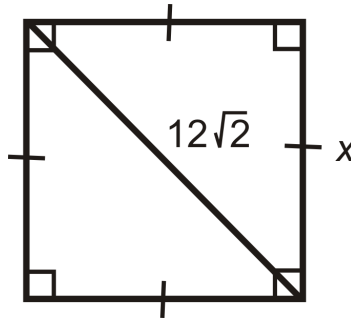

3. x is the hypotenuse of a 45-45-90 triangle with leg lengths of $5\sqrt{3}$.

Answers:

1. Use the $x : x : x\sqrt{2}$ ratio. $AB = 9\sqrt{2}$ because it is equal to AC . So, $BC = 9\sqrt{2} \cdot \sqrt{2} = 9 \cdot 2 = 18$.
2. Use the $x : x : x\sqrt{2}$ ratio. We need to solve for x in the ratio.

$$12\sqrt{2} = x\sqrt{2}$$

$$12 = x$$

3. $x = 5\sqrt{3} \cdot \sqrt{2} = 5\sqrt{6}$

Practice

1. In an isosceles right triangle, if a leg is x , then the hypotenuse is _____.
2. In an isosceles right triangle, if the hypotenuse is x , then each leg is _____.
3. A square has sides of length 15. What is the length of the diagonal?
4. A square's diagonal is 22. What is the length of each side?
5. A square has sides of length $6\sqrt{2}$. What is the length of the diagonal?
6. A square has sides of length $4\sqrt{3}$. What is the length of the diagonal?
7. A baseball diamond is a square with 90 foot sides. What is the distance from home base to second base? (HINT: It's the length of the diagonal).
8. Four isosceles triangles are formed when both diagonals are drawn in a square. If the length of each side in the square is s , what are the lengths of the legs of the isosceles triangles?

Find the lengths of the missing sides. Simplify all radicals.

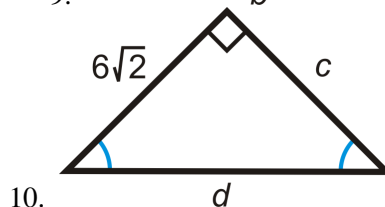
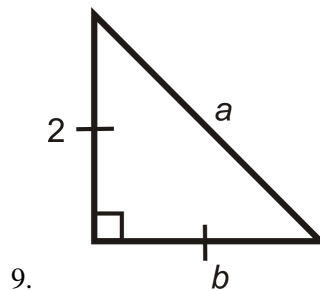

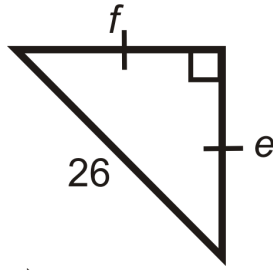

11.

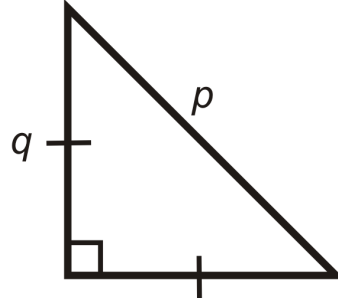

12.

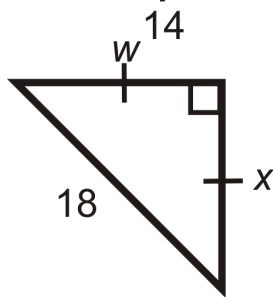

13.

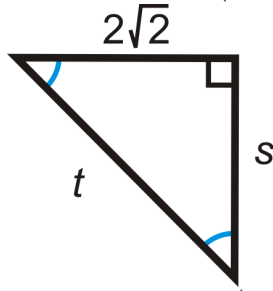

14.

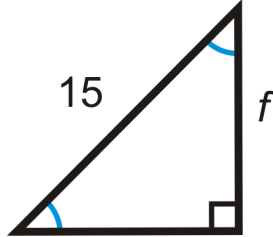

15.

8.5 30-60-90 Right Triangles

Here you'll learn that the sides of a 30-60-90 right triangle are in the ratio $x : x\sqrt{3} : 2x$.

What if you were given a 30-60-90 right triangle and the length of one of its side? How could you figure out the lengths of its other sides? After completing this Concept, you'll be able to use the 30-60-90 Theorem to solve problems like this one.

Watch This



MEDIA

Click image to the left for more content.

[CK-12 Foundation: Chapter8306090RightTrianglesA](#)

Watch the first half of this video.

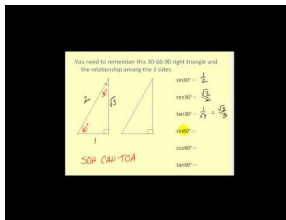

MEDIA

Click image to the left for more content.

[James Sousa:Trigonometric Function Values of Special Angles](#)

Now watch the first half of this video.

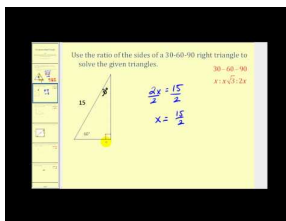

MEDIA

Click image to the left for more content.

[James Sousa:SolvingSpecialRight Triangles](#)

Guidance

One of the special right triangles is called a 30-60-90 triangle, after its three angles. To construct a 30-60-90 triangle, start with an equilateral triangle.

Investigation: Properties of a 30-60-90 Triangle

Tools Needed: Pencil, paper, ruler, compass

1. Construct an equilateral triangle with 2 in sides.

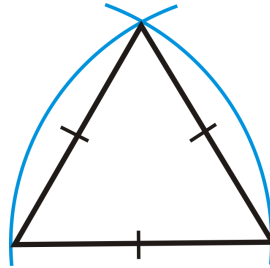

2. Draw or construct the altitude from the top vertex to the base for two congruent triangles.
3. Find the measure of the two angles at the top vertex and the length of the shorter leg.

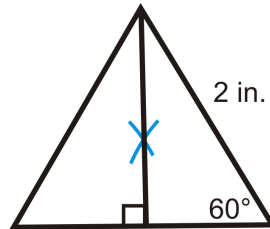

The top angles are each 30° and the shorter leg is 1 in because the altitude of an equilateral triangle is also the angle and perpendicular bisector.

4. Find the length of the longer leg, using the Pythagorean Theorem. Simplify the radical.
5. Now, let's say the shorter leg is length x and the hypotenuse is $2x$. Use the Pythagorean Theorem to find the longer leg. What is it? How is this similar to your answer in #4?

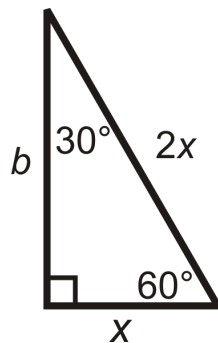

$$x^2 + b^2 = (2x)^2$$

$$x^2 + b^2 = 4x^2$$

$$b^2 = 3x^2$$

$$b = x\sqrt{3}$$

30-60-90 Corollary: If a triangle is a 30-60-90 triangle, then its sides are in the extended ratio $x : x\sqrt{3} : 2x$.

Step 5 in the above investigation proves the 30-60-90 Corollary. The shortest leg is always x , the longest leg is always $x\sqrt{3}$, and the hypotenuse is always $2x$. If you ever forget this corollary, then you can still use the Pythagorean Theorem.

Example A

Find the length of the missing sides.

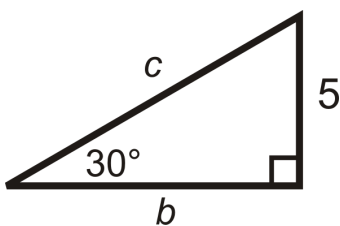

We are given the shortest leg. If $x = 5$, then the longer leg, $b = 5\sqrt{3}$, and the hypotenuse, $c = 2(5) = 10$.

Example B

Find the value of x and y .

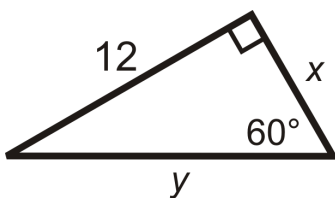

We are given the longer leg.

$$\begin{aligned} x\sqrt{3} &= 12 \\ x &= \frac{12}{\sqrt{3}} \cdot \frac{\sqrt{3}}{\sqrt{3}} \\ x &= \frac{12\sqrt{3}}{3} \\ x &= 4\sqrt{3} \end{aligned}$$

Then, the hypotenuse would be $y = 2(4\sqrt{3}) = 8\sqrt{3}$.

Example C

Find the measure of x .

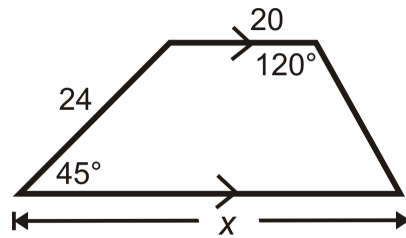

Think of this trapezoid as a rectangle, between a 45-45-90 triangle and a 30-60-90 triangle.

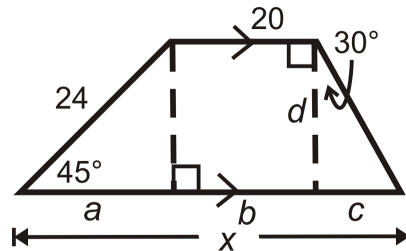

From this picture, $x = a + b + c$. First, find a , which is a leg of an isosceles right triangle.

$$a = \frac{24}{\sqrt{2}} \cdot \frac{\sqrt{2}}{\sqrt{2}} = \frac{24\sqrt{2}}{2} = 12\sqrt{2}$$

$a = d$, so we can use this to find c , which is the shorter leg of a 30-60-90 triangle.

$$c = \frac{12\sqrt{2}}{\sqrt{3}} \cdot \frac{\sqrt{3}}{\sqrt{3}} = \frac{12\sqrt{6}}{3} = 4\sqrt{6}$$

$b = 20$, so $x = 12\sqrt{2} + 20 + 4\sqrt{6}$. Nothing simplifies, so this is how we leave our answer.

Watch this video for help with the Examples above.



MEDIA

Click image to the left for more content.

[CK-12 Foundation: Chapter8306090RightTrianglesB](#)

Vocabulary

A **right triangle** is a triangle with a 90° angle. A **30-60-90 triangle** is a right triangle with angle measures of 30° , 60° , and 90° .

Guided Practice

1. Find the length of the missing sides.

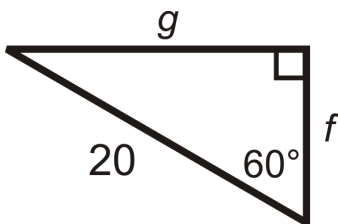

2. Find the value of x and y .

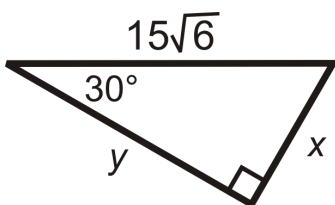

3. x is the hypotenuse of a 30-60-90 triangle and y is the longer leg of the same triangle. The shorter leg has a length of 6.

Answers:

1. We are given the hypotenuse. $2x = 20$, so the shorter leg, $f = 10$, and the longer leg, $g = 10\sqrt{3}$.
 2. We are given the hypotenuse.

$$2x = 15\sqrt{6}$$

$$x = \frac{15\sqrt{6}}{2}$$

The, the longer leg would be $y = \left(\frac{15\sqrt{6}}{2}\right) \cdot \sqrt{3} = \frac{15\sqrt{18}}{2} = \frac{45\sqrt{2}}{2}$

3. We are given the shorter leg.

$$x = 2(6)$$

$$x = 12$$

The longer leg is

$$\text{and } y = 6 \cdot \sqrt{3} = 6\sqrt{3}$$

Practice

1. In a 30-60-90 triangle, if the shorter leg is 5, then the longer leg is _____ and the hypotenuse is _____.

2. In a 30-60-90 triangle, if the shorter leg is x , then the longer leg is _____ and the hypotenuse is _____.
3. A rectangle has sides of length 6 and $6\sqrt{3}$. What is the length of the diagonal?
4. Two (opposite) sides of a rectangle are 10 and the diagonal is 20. What is the length of the other two sides?

For questions 5-12, find the lengths of the missing sides. Simplify all radicals.

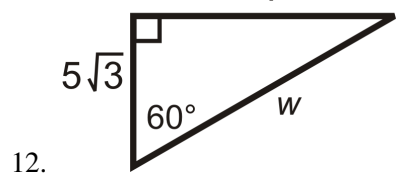
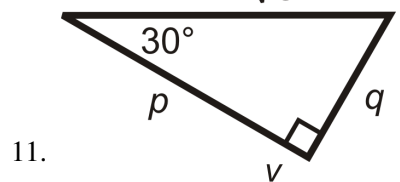
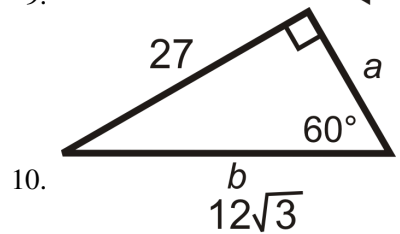
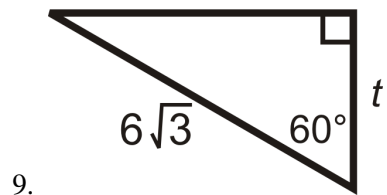
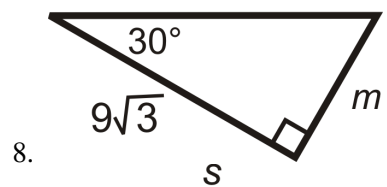
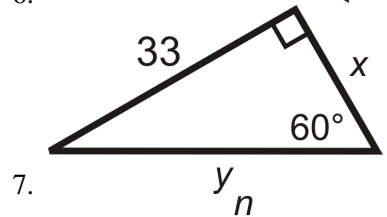
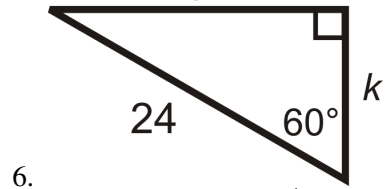
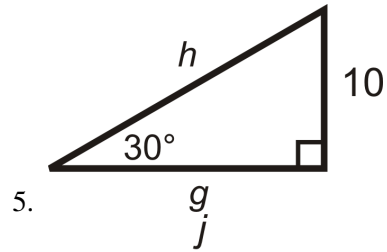

13. What is the height of an equilateral triangle with sides of length 3 in?
14. What is the area of an equilateral triangle with sides of length 5 ft?
15. A regular hexagon has sides of length 3 in. What is the area of the hexagon? (*Hint: the hexagon is made up a 6 equilateral triangles.*)
16. The area of an equilateral triangle is $36\sqrt{3}$. What is the length of a side?
17. If a road has a grade of 30° , this means that its angle of elevation is 30° . If you travel 1.5 miles on this road, how much elevation have you gained in feet (5280 ft = 1 mile)?

8.6 Sine, Cosine, Tangent

Here you'll learn what the three trigonometric ratios are and how to find their value for a right triangle's non-right angle.

What if you were given a right triangle and told that its sides measure 3, 4, and 5 inches? How could you find the sine, cosine, and tangent of one of the triangle's non-right angles? After completing this Concept, you'll be able to solve for these trigonometric ratios.

Watch This



MEDIA

Click image to the left for more content.

CK-12 Foundation: Chapter8SoneCosineTangentA

Watch the parts of the video dealing with the sine, cosine, and tangent.

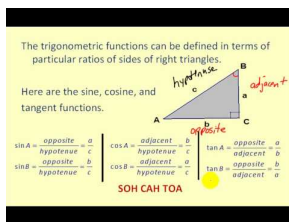

MEDIA

Click image to the left for more content.

James Sousa:Introduction toTrigonometric FunctionsUsing Triangles

Guidance

The word trigonometry comes from two words meaning *triangle* and *measure*. In this lesson we will define three trigonometric (or trig) functions.

Trigonometry: The study of the relationships between the sides and angles of right triangles.

In trigonometry, sides are named in reference to a particular angle. The hypotenuse of a triangle is always the same, but the terms **adjacent** and **opposite** depend on which angle you are referencing. A side adjacent to an angle is the leg of the triangle that helps form the angle. A side opposite to an angle is the leg of the triangle that does not help form the angle. We never reference the right angle when referring to trig ratios.

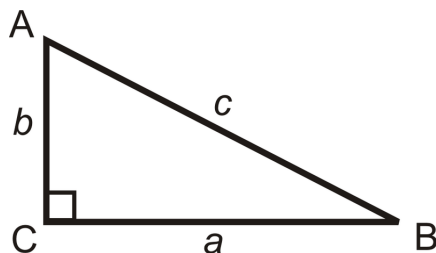

The three basic trig ratios are called, sine, cosine and tangent. At this point, we will only take the sine, cosine and tangent of acute angles. However, you will learn that you can use these ratios with obtuse angles as well.

Sine Ratio: For an acute angle x in a right triangle, the $\sin x$ is equal to the ratio of the side opposite the angle over the hypotenuse of the triangle. Using the triangle above, $\sin A = \frac{a}{c}$ and $\sin B = \frac{b}{c}$.

Cosine Ratio: For an acute angle x in a right triangle, the $\cos x$ is equal to the ratio of the side adjacent to the angle over the hypotenuse of the triangle. Using the triangle above, $\cos A = \frac{b}{c}$ and $\cos B = \frac{a}{c}$.

Tangent Ratio: For an acute angle x , in a right triangle, the $\tan x$ is equal to the ratio of the side opposite to the angle over the side adjacent to x . Using the triangle above, $\tan A = \frac{a}{b}$ and $\tan B = \frac{b}{a}$.

There are a few important things to note about the way we write these ratios. First, keep in mind that the abbreviations $\sin x$, $\cos x$, and $\tan x$ are all functions. Second, be careful when using the abbreviations that you still pronounce the full name of each function. When we write $\sin x$ it is still pronounced *sine*, with a long “i”. When we write $\cos x$, we still say co-sine. And when we write $\tan x$, we still say tangent. An easy way to remember ratios is to use the pneumonic SOH-CAH-TOA.

$$\text{Sine} = \frac{\text{Opposite}}{\text{Hypotenuse}} \quad \text{Cosine} = \frac{\text{Adjacent}}{\text{Hypotenuse}} \quad \text{Tangent} = \frac{\text{Opposite}}{\text{Adjacent}}$$

A few important points:

- Always reduce ratios when you can.
- Use the Pythagorean Theorem to find the missing side (if there is one).
- The tangent ratio can be bigger than 1 (the other two cannot).
- If two right triangles are similar, then their sine, cosine, and tangent ratios will be the same (because they will reduce to the same ratio).
- If there is a radical in the denominator, rationalize the denominator.
- The sine, cosine and tangent for an angle are fixed.

Example A

Find the sine, cosine and tangent ratios of $\angle A$.

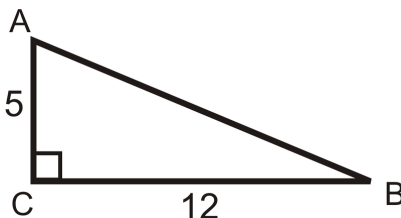

First, we need to use the Pythagorean Theorem to find the length of the hypotenuse.

$$5^2 + 12^2 = h^2$$

$$13 = h$$

So, $\sin A = \frac{12}{13}$, $\cos A = \frac{5}{13}$, and $\tan A = \frac{12}{5}$.

Example B

Find the sine, cosine, and tangent of $\angle B$.

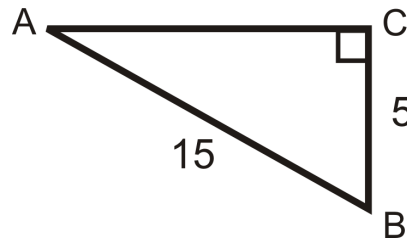

Find the length of the missing side.

$$AC^2 + 5^2 = 15^2$$

$$AC^2 = 200$$

$$AC = 10\sqrt{2}$$

Therefore, $\sin B = \frac{10\sqrt{2}}{15} = \frac{2\sqrt{2}}{3}$, $\cos B = \frac{5}{15} = \frac{1}{3}$, and $\tan B = \frac{10\sqrt{2}}{5} = 2\sqrt{2}$.

Example C

Find the sine, cosine and tangent of 30° .

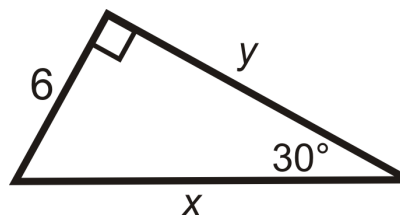

This is a special right triangle, a 30-60-90 triangle. So, if the short leg is 6, then the long leg is $6\sqrt{3}$ and the hypotenuse is 12.

$$\sin 30^\circ = \frac{6}{12} = \frac{1}{2}, \cos 30^\circ = \frac{6\sqrt{3}}{12} = \frac{\sqrt{3}}{2}, \text{ and } \tan 30^\circ = \frac{6}{6\sqrt{3}} = \frac{1}{\sqrt{3}} \cdot \frac{\sqrt{3}}{\sqrt{3}} = \frac{\sqrt{3}}{3}.$$

Watch this video for help with the Examples above.



MEDIA

Click image to the left for more content.

CK-12 Foundation: Chapter8SineCosineTangentB

Concept Problem Revisited

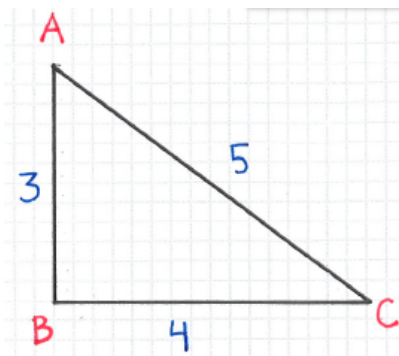

The trigonometric ratios for the non-right angles in the triangle above are:

$$\sin A = \frac{4}{5}, \cos A = \frac{3}{5}, \tan A = \frac{4}{3}, \sin B = \frac{3}{5}, \cos B = \frac{4}{5}, \text{ and } \tan B = \frac{3}{4}.$$

Vocabulary

Trigonometry is the study of the relationships between the sides and angles of right triangles. The legs are called *adjacent* or *opposite* depending on which *acute* angle is being used. The three trigonometric (or trig) ratios are *sine*, *cosine*, and *tangent*.

Guided Practice

Answer the questions about the following image. Reduce all fractions.

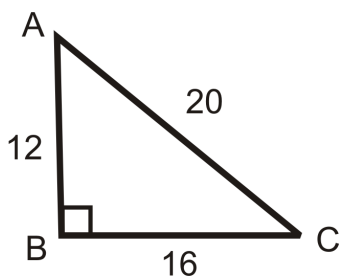

1. What is $\sin A$?
2. What is $\cos A$?
3. What is $\tan A$?

Answers:

1. $\sin A = \frac{16}{20} = \frac{4}{5}$
2. $\cos A = \frac{12}{20} = \frac{3}{5}$
3. $\tan A = \frac{16}{12} = \frac{4}{3}$

Practice

Use the diagram to fill in the blanks below.

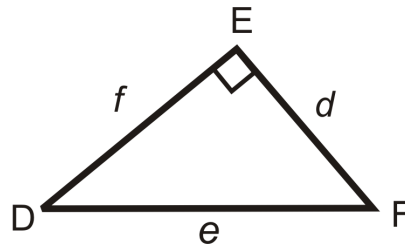

1. $\tan D = \frac{?}{?}$
2. $\sin F = \frac{?}{?}$
3. $\tan F = \frac{?}{?}$
4. $\cos F = \frac{?}{?}$
5. $\sin D = \frac{?}{?}$
6. $\cos D = \frac{?}{?}$

From questions 1-6, we can conclude the following. Fill in the blanks.

7. $\cos \underline{\quad} = \sin F$ and $\sin \underline{\quad} = \cos F$.
8. $\tan D$ and $\tan F$ are of each other.

Find the sine, cosine and tangent of $\angle A$. Reduce all fractions and radicals.

- 9.
- 10.
- 11.

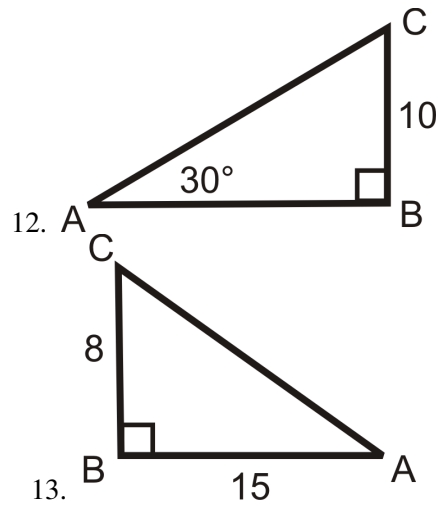

14. Explain why the sine of an angle will never be greater than 1.
15. Explain why the tangent of a 45° angle will always be 1.
16. As the degree of an angle increases, will the tangent of the angle increase or decrease? Explain.

8.7 Trigonometric Ratios with a Calculator

Here you'll learn how to solve for missing sides in right triangles that are not one of the special right triangles.

What if you wanted to find the missing sides of a right triangle with angles of 20° and 70° and a hypotenuse length of 10 inches? How could you use trigonometry to help you? After completing this Concept, you'll be able to solve problems like this one.

Watch This



MEDIA

Click image to the left for more content.

CK-12 Foundation: Chapter8TrigonometricRatioswithaCalculatorA

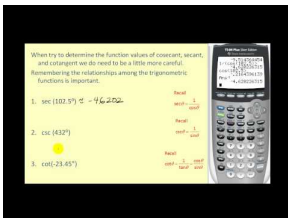

MEDIA

Click image to the left for more content.

James Sousa:DeterminingTrigonometric Function Values on the Calculator

Guidance

The trigonometric ratios are not dependent on the exact side lengths, but the angles. There is one fixed value for every angle, from 0° to 90° . Your scientific (or graphing) calculator knows the values of the sine, cosine and tangent of all of these angles. Depending on your calculator, you should have [SIN], [COS], and [TAN] buttons. Use these to find the sine, cosine, and tangent of any acute angle. One application of the trigonometric ratios is to use them to find the missing sides of a right triangle. All you need is one angle, other than the right angle, and one side.

Example A

Find the trigonometric value, using your calculator. Round to 4 decimal places.

- $\sin 78^\circ$
- $\cos 60^\circ$
- $\tan 15^\circ$

Depending on your calculator, you enter the degree and then press the trig button or the other way around. Also, make sure the mode of your calculator is in *DEGREES*.

a) $\sin 78^\circ = 0.97815$

b) $\cos 60^\circ = 0.5$

c) $\tan 15^\circ = 0.26795$

Example B

Find the value of each variable. Round your answer to the nearest tenth.

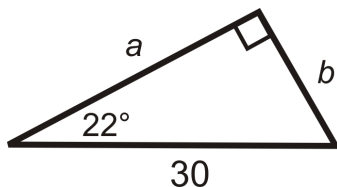

We are given the hypotenuse. Use *sine* to find b , and *cosine* to find a . Use your calculator to evaluate the sine and cosine of the angles.

$$\begin{aligned} \sin 22^\circ &= \frac{b}{30} & \cos 22^\circ &= \frac{a}{30} \\ 30 \cdot \sin 22^\circ &= b & 30 \cdot \cos 22^\circ &= a \\ b &\approx 11.2 & a &\approx 27.8 \end{aligned}$$

Example C

Find the value of each variable. Round your answer to the nearest tenth.

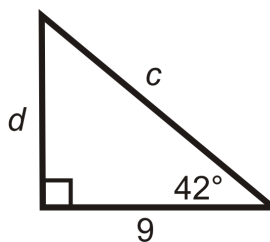

We are given the adjacent leg to 42° . To find c , use *cosine* and use *tangent* to find d .

$$\begin{aligned} \cos 42^\circ &= \frac{\text{adjacent}}{\text{hypotenuse}} = \frac{9}{c} & \tan 42^\circ &= \frac{\text{opposite}}{\text{adjacent}} = \frac{d}{9} \\ c \cdot \cos 42^\circ &= 9 & 9 \cdot \tan 42^\circ &= d \\ c &= \frac{9}{\cos 42^\circ} \approx 12.1 & d &\approx 27.0 \end{aligned}$$

Any time you use trigonometric ratios, use only the information that you are given. This will result in the most accurate answers.

Watch this video for help with the Examples above.



MEDIA

 Click image to the left for more content.

CK-12 Foundation: Chapter8TrigonometricRatioswithaCalculatorB

Concept Problem Revisited

Use trigonometric ratios to find the missing sides. Round to the nearest tenth.

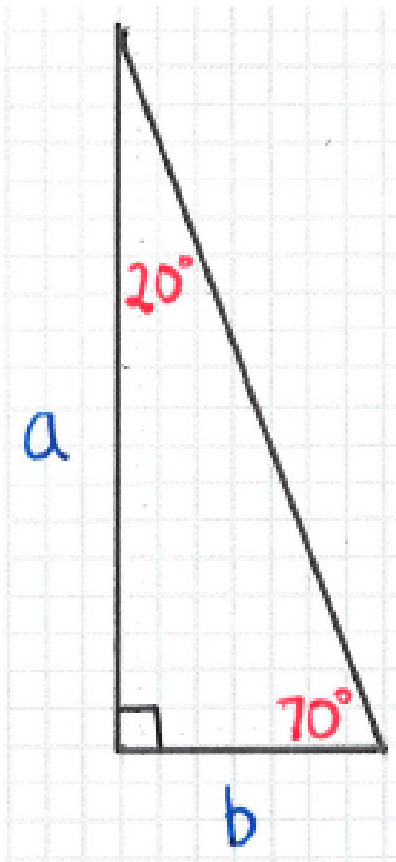

Find the length of a and b using sine or cosine ratios:

$$\begin{aligned}\cos 20^\circ &= \frac{a}{10} \\ 10 \cdot \cos 20^\circ &= a \\ a &\approx 9.4\end{aligned}$$

$$\begin{aligned}\sin 20^\circ &= \frac{b}{10} \\ 10 \cdot \sin 20^\circ &= b \\ b &\approx 3.4\end{aligned}$$

$$\begin{aligned}\sin 70^\circ &= \frac{a}{10} \\ 10 \cdot \sin 70^\circ &= a \\ a &\approx 9.4\end{aligned}$$

$$\begin{aligned}\cos 70^\circ &= \frac{b}{10} \\ 10 \cdot \cos 70^\circ &= b \\ b &\approx 3.4\end{aligned}$$

Vocabulary

Trigonometry is the study of the relationships between the sides and angles of right triangles. The legs are called *adjacent* or *opposite* depending on which *acute* angle is being used. The three trigonometric (or trig) ratios are *sine*, *cosine*, and *tangent*.

Guided Practice

1. What is $\tan 45^\circ$?
2. Find the length of the missing sides and round your answers to the nearest tenth:

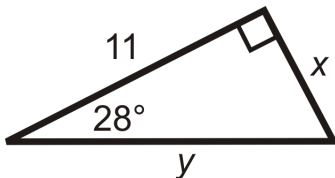

3. Find the length of the missing sides and round your answers to the nearest tenth:

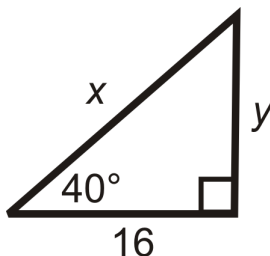

Answers:

1. Using your calculator, you should find that $\tan 45^\circ = 1$?
2. Use tangent for x and cosine for y .

$$\begin{aligned}\tan 28^\circ &= \frac{x}{11} \\ 11 \cdot \tan 28^\circ &= x \\ x &\approx 5.8\end{aligned}$$

$$\begin{aligned}\cos 28^\circ &= \frac{11}{y} \\ \frac{11}{\cos 28^\circ} &= y \\ y &\approx 12.5\end{aligned}$$

3. Use tangent for y and cosine for x .

$$\begin{aligned}\tan 40^\circ &= \frac{y}{16} \\ 16 \cdot \tan 40^\circ &= y \\ y &\approx 13.4\end{aligned}$$

$$\begin{aligned}\cos 40^\circ &= \frac{16}{x} \\ \frac{16}{\cos 40^\circ} &= x \\ x &\approx 20.9\end{aligned}$$

Practice

Use your calculator to find the value of each trig function below. Round to four decimal places.

1. $\sin 24^\circ$
2. $\cos 45^\circ$
3. $\tan 88^\circ$
4. $\sin 43^\circ$
5. $\tan 12^\circ$
6. $\cos 79^\circ$
7. $\sin 82^\circ$

Find the length of the missing sides. Round your answers to the nearest tenth.

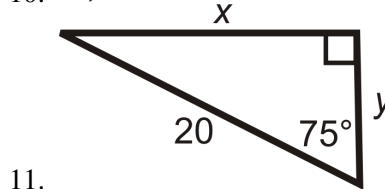
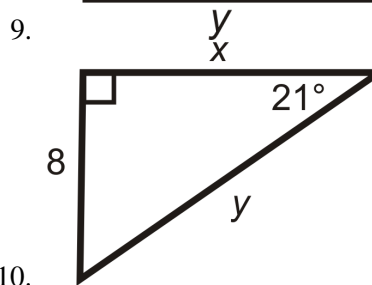
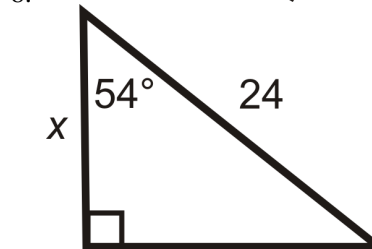
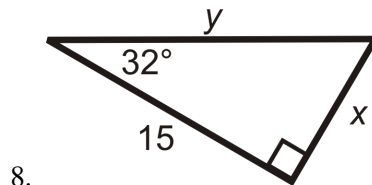

12. Find $\sin 80^\circ$ and $\cos 10^\circ$.
13. Use your knowledge of where the trigonometric ratios come from to explain your result to the previous question.
14. Generalize your result to the previous two questions. If $\sin \theta = x$, then $\cos ? = x$.
15. How are $\tan \theta$ and $\tan(90 - \theta)$ related? Explain.

8.8 Trigonometry Word Problems

Here you'll learn how to use the trigonometric ratios to solve word problems.

What if a restaurant needed to build a wheelchair ramp for its customers? The angle of elevation for a ramp is recommended to be 5° . If the vertical distance from the sidewalk to the front door is two feet, what is the horizontal distance that the ramp will take up (x)? How long will the ramp be (y)? Round your answers to the nearest hundredth. After completing this Concept, you'll be able to use trigonometry to solve this problem.

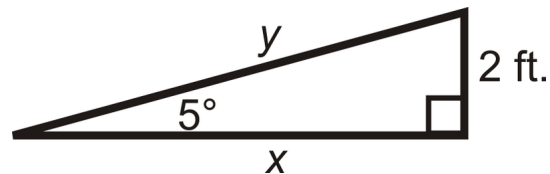

Watch This



MEDIA

Click image to the left for more content.

CK-12 Foundation: Chapter8TrigonometryWordProblemsA

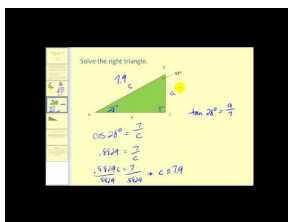

MEDIA

Click image to the left for more content.

James Sousa:SolvingRight Triangles- The Basics

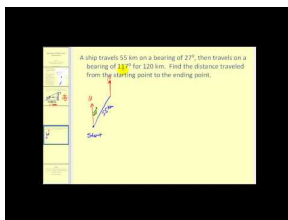

MEDIA

Click image to the left for more content.

James Sousa:SolvingRight Triangles- Applications

Guidance

A practical application of the trigonometric functions is to find the measure of lengths that you cannot measure. Very frequently, angles of depression and elevation are used in these types of problems.

Angle of Depression: The angle measured from the horizon or horizontal line, down.



Angle of Elevation: The angle measure from the horizon or horizontal line, up.

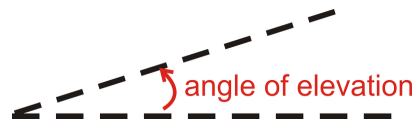

Example A

An inquisitive math student is standing 25 feet from the base of the Washington Monument. The angle of elevation from her horizontal line of sight is 87.4° . If her “eye height” is 5ft, how tall is the monument?



Solution: We can find the height of the monument by using the tangent ratio and then adding the eye height of the student.

$$\tan 87.4^\circ = \frac{h}{25}$$

$$h = 25 \cdot \tan 87.4^\circ = 550.54$$

Adding 5 ft, the total height of the Washington Monument is 555.54 ft.

According to Wikipedia, the actual height of the monument is 555.427 ft.

Example B

A 25 foot tall flagpole casts a 42 foot shadow. What is the angle that the sun hits the flagpole?

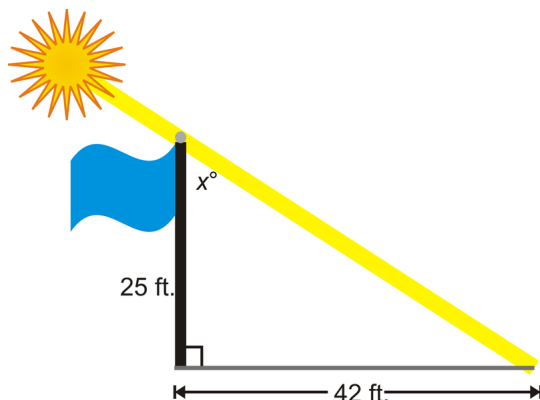

Draw a picture. The angle that the sun hits the flagpole is x° . We need to use the inverse tangent ratio.

$$\tan x = \frac{42}{25}$$

$$\tan^{-1} \frac{42}{25} \approx 59.2^\circ = x$$

Example C

Elise is standing on top of a 50 foot building and sees her friend, Molly. If Molly is 30 feet away from the base of the building, what is the angle of depression from Elise to Molly? Elise's eye height is 4.5 feet.

Because of parallel lines, the angle of depression is equal to the angle at Molly, or x° . We can use the inverse tangent ratio.

$$\tan^{-1} \left(\frac{54.5}{30} \right) = 61.2^\circ = x$$

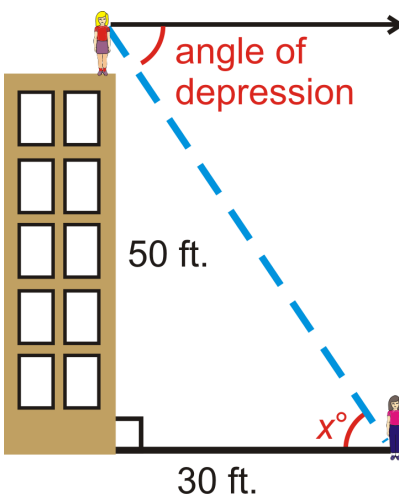

Watch this video for help with the Examples above.



MEDIA

 Click image to the left for more content.

CK-12 Foundation: Chapter8TrigonometryWordProblemsB

Concept Problem Revisited

To find the horizontal length and the actual length of the ramp, we need to use the tangent and sine.

$$\begin{aligned}\tan 5^\circ &= \frac{2}{x} \\ x &= \frac{2}{\tan 5^\circ} = 22.86\end{aligned}$$

$$\begin{aligned}\sin 5^\circ &= \frac{2}{y} \\ y &= \frac{2}{\sin 5^\circ} = 22.95\end{aligned}$$

Vocabulary

Trigonometry is the study of the relationships between the sides and angles of right triangles. The legs are called *adjacent* or *opposite* depending on which *acute* angle is being used. The three trigonometric (or trig) ratios are *sine*, *cosine*, and *tangent*. The *angle of depression* is the angle measured down from the horizon or a horizontal line. The *angle of elevation* is the angle measured up from the horizon or a horizontal line.

Guided Practice

1. Mark is flying a kite and realizes that 300 feet of string are out. The angle of the string with the ground is 42.5° . How high is Mark's kite above the ground?
2. A 20 foot ladder rests against a wall. The base of the ladder is 7 feet from the wall. What angle does the ladder make with the ground?
3. A 20 foot ladder rests against a wall. The ladder makes a 55° angle with the ground. How far from the wall is the base of the ladder?

Answers

1. It might help to draw a picture. Then write and solve a trig equation.

$$\begin{aligned}\sin 42.5^\circ &= \frac{x}{300} \\ 300 \cdot \sin 42.5^\circ &= x \\ x &\approx 202.7\end{aligned}$$

The kite is about 202.7 feet off of the ground.

2. It might help to draw a picture.

$$\cos x = \frac{7}{20}$$

$$x = \cos^{-1} \frac{7}{20}$$

$$x \approx 69.5^\circ$$

3. It might help to draw a picture.

$$\cos 55^\circ = \frac{x}{20}$$

$$20 \cdot \cos 55^\circ = x$$

$$x \approx 11.5 \text{ ft}$$

Practice

- Kristin is swimming in the ocean and notices a coral reef below her. The angle of depression is 35° and the depth of the ocean, at that point is 250 feet. How far away is she from the reef?

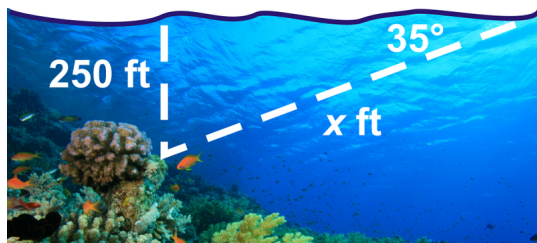

- The Leaning Tower of Pisa currently “leans” at a 4° angle and has a vertical height of 55.86 meters. How tall was the tower when it was originally built?

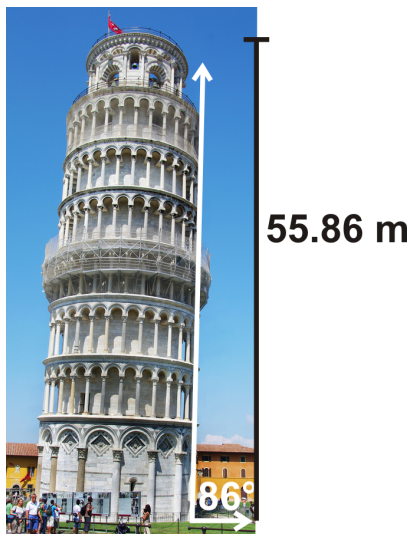

- The angle of depression from the top of an apartment building to the base of a fountain in a nearby park is 72° . If the building is 78 ft tall, how far away is the fountain?

4. William spots a tree directly across the river from where he is standing. He then walks 20 ft upstream and determines that the angle between his previous position and the tree on the other side of the river is 65° . How wide is the river?
5. Diego is flying his kite one afternoon and notices that he has let out the entire 120 ft of string. The angle his string makes with the ground is 52° . How high is his kite at this time?
6. A tree struck by lightning in a storm breaks and falls over to form a triangle with the ground. The tip of the tree makes a 36° angle with the ground 25 ft from the base of the tree. What was the height of the tree to the nearest foot?
7. Upon descent an airplane is 20,000 ft above the ground. The air traffic control tower is 200 ft tall. It is determined that the angle of elevation from the top of the tower to the plane is 15° . To the nearest mile, find the ground distance from the airplane to the tower.
8. A 75 foot building casts an 82 foot shadow. What is the angle that the sun hits the building?
9. Over 2 miles (horizontal), a road rises 300 feet (vertical). What is the angle of elevation?
10. A boat is sailing and spots a shipwreck 650 feet below the water. A diver jumps from the boat and swims 935 feet to reach the wreck. What is the angle of depression from the boat to the shipwreck?
11. Elizabeth wants to know the angle at which the sun hits a tree in her backyard at 3 pm. She finds that the length of the tree's shadow is 24 ft at 3 pm. At the same time of day, her shadow is 6 ft 5 inches. If Elizabeth is 4 ft 8 inches tall, find the height of the tree and hence the angle at which the sunlight hits the tree.
12. Alayna is trying to determine the angle at which to aim her sprinkler nozzle to water the top of a 5 ft bush in her yard. Assuming the water takes a straight path and the sprinkler is on the ground 4 ft from the tree, at what angle of inclination should she set it?
13. Tommy was solving the triangle below and made a mistake. What did he do wrong?

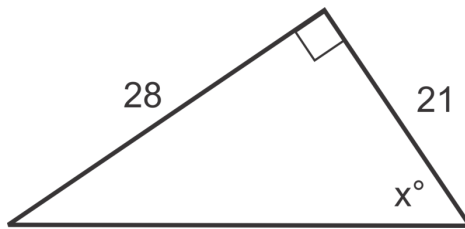

$$\tan^{-1}\left(\frac{21}{28}\right) \approx 36.9^\circ$$

14. Tommy then continued the problem and set up the equation: $\cos 36.9^\circ = \frac{21}{h}$. By solving this equation he found that the hypotenuse was 26.3 units. Did he use the correct trigonometric ratio here? Is his answer correct? Why or why not?
15. How could Tommy have found the hypotenuse in the triangle another way and avoided making his mistake?

8.9 Inverse Trigonometric Ratios

Here you'll learn how to use inverse trigonometric ratios to solve for missing angles in right triangles.

What if you were told that the longest escalator in North America is at the Wheaton Metro Station in Maryland and is 230 feet long and is 115 ft high? What is the angle of elevation, x° , of this escalator? After completing this Concept, you'll be able use inverse trigonometry to answer this question.



Watch This



MEDIA

Click image to the left for more content.

[CK-12 Foundation: Chapter8InverseTrigonometricRatiosA](#)

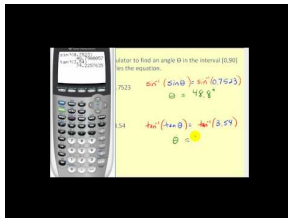

MEDIA

Click image to the left for more content.

[James Sousa:Introduction toInverseTrigonometric Functions](#)

Guidance

The word *inverse* is probably familiar to you. In mathematics, once you learn how to do an operation, you also learn how to “undo” it. For example, you may remember that addition and subtraction are considered inverse operations. Multiplication and division are also inverse operations. In algebra you used inverse operations to solve equations

and inequalities. When we apply the word inverse to the trigonometric ratios, we can find the acute angle measures within a right triangle. Normally, if you are given an angle and a side of a right triangle, you can find the other two sides, using sine, cosine or tangent. With the inverse trig ratios, you can find the angle measure, given two sides.

Inverse Tangent: If you know the opposite side and adjacent side of an angle in a right triangle, you can use inverse tangent to find the measure of the angle. Inverse tangent is also called arctangent and is labeled \tan^{-1} or *arctan*. The “-1” indicates inverse.

Inverse Sine: If you know the opposite side of an angle and the hypotenuse in a right triangle, you can use inverse sine to find the measure of the angle. Inverse sine is also called arcsine and is labeled \sin^{-1} or *arcsin*.

Inverse Cosine: If you know the adjacent side of an angle and the hypotenuse in a right triangle, you can use inverse cosine to find the measure of the angle. Inverse cosine is also called arccosine and is labeled \cos^{-1} or *arccos*.

Using the triangle below, the inverse trigonometric ratios look like this:

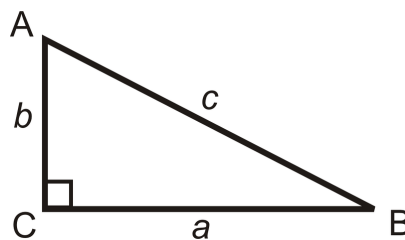

$$\tan^{-1}\left(\frac{b}{a}\right) = m\angle B$$

$$\tan^{-1}\left(\frac{a}{b}\right) = m\angle A$$

$$\sin^{-1}\left(\frac{b}{c}\right) = m\angle B$$

$$\sin^{-1}\left(\frac{a}{c}\right) = m\angle A$$

$$\cos^{-1}\left(\frac{a}{c}\right) = m\angle B$$

$$\cos^{-1}\left(\frac{b}{c}\right) = m\angle A$$

In order to actually find the measure of the angles, you will need you use your calculator. On most scientific and graphing calculators, the buttons look like $[\text{SIN}^{-1}]$, $[\text{COS}^{-1}]$, and $[\text{TAN}^{-1}]$. Typically, you might have to hit a shift or 2nd button to access these functions. For example, on the TI-83 and 84, $[2^{\text{nd}}][\text{SIN}]$ is $[\text{SIN}^{-1}]$. Again, make sure the mode is in degrees.

Now that we know how to use inverse trigonometric ratios to find the measure of the acute angles in a right triangle, we can solve right triangles. To solve a right triangle, you would need to find all sides and angles in a right triangle, using any method. When solving a right triangle, you could use sine, cosine or tangent, inverse sine, inverse cosine, or inverse tangent, or the Pythagorean Theorem. Remember when solving right triangles to only use the values that you are given.

Example A

Use the sides of the triangle and your calculator to find the value of $\angle A$. Round your answer to the nearest tenth of a degree.

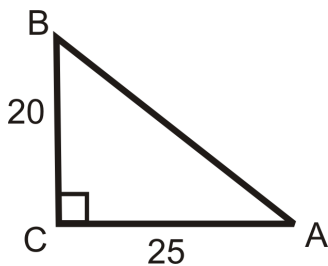

In reference to $\angle A$, we are given the *opposite* leg and the *adjacent* leg. This means we should use the *tangent* ratio.

$\tan A = \frac{20}{25} = \frac{4}{5}$, therefore $\tan^{-1}\left(\frac{4}{5}\right) = m\angle A$. Use your calculator.

If you are using a TI-83 or 84, the keystrokes would be: $[2^{nd}][\text{TAN}]\left(\frac{4}{5}\right)[\text{ENTER}]$ and the screen looks like:

So, $m\angle A = 38.7^\circ$

Example B

$\angle A$ is an acute angle in a right triangle. Use your calculator to find $m\angle A$ to the nearest tenth of a degree.

- a) $\sin A = 0.68$
- b) $\cos A = 0.85$
- c) $\tan A = 0.34$

Solutions:

- a) $m\angle A = \sin^{-1} 0.68 = 42.8^\circ$
- b) $m\angle A = \cos^{-1} 0.85 = 31.8^\circ$
- c) $m\angle A = \tan^{-1} 0.34 = 18.8^\circ$

Example C

Solve the right triangle.

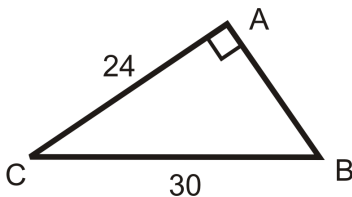

To solve this right triangle, we need to find AB , $m\angle C$ and $m\angle B$. Use AC and CB to give the most accurate answers.

AB : Use the Pythagorean Theorem.

$$\begin{aligned}24^2 + AB^2 &= 30^2 \\576 + AB^2 &= 900 \\AB^2 &= 324 \\AB &= \sqrt{324} = 18\end{aligned}$$

$m\angle B$: Use the inverse sine ratio.

$$\begin{aligned}\sin B &= \frac{24}{30} = \frac{4}{5} \\ \sin^{-1}\left(\frac{4}{5}\right) &= 53.1^\circ = m\angle B\end{aligned}$$

$m\angle C$: Use the inverse cosine ratio.

$$\begin{aligned}\cos C &= \frac{24}{30} = \frac{4}{5} \\ \cos^{-1}\left(\frac{4}{5}\right) &= 36.9^\circ = m\angle C\end{aligned}$$

Watch this video for help with the Examples above.



MEDIA

Click image to the left for more content.

[CK-12 Foundation: Chapter8InverseTrigonometricRatiosB](#)

Concept Problem Revisited

To find the escalator's angle of elevation, we need to use the inverse sine ratio.

$$\sin^{-1}\left(\frac{115}{230}\right) = 30^\circ \quad \text{The angle of elevation is } 30^\circ.$$

Vocabulary

Trigonometry is the study of the relationships between the sides and angles of right triangles. The legs are called *adjacent* or *opposite* depending on which *acute* angle is being used. The three trigonometric (or trig) ratios are *sine*, *cosine*, and *tangent*. The *inverse* trig ratios, \sin^{-1} , \cos^{-1} , and \tan^{-1} , allow us to find missing angles when we are given sides.

Guided Practice

1. Solve the right triangle.

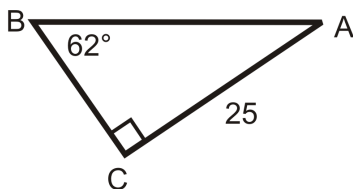

2. Solve the right triangle.

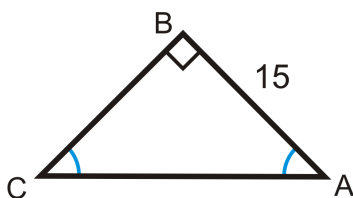
**Answers:**

1. To solve this right triangle, we need to find AB , BC and $m\angle A$.

AB : Use sine ratio.

$$\begin{aligned}\sin 62^\circ &= \frac{25}{AB} \\ AB &= \frac{25}{\sin 62^\circ} \\ AB &\approx 28.31\end{aligned}$$

BC : Use tangent ratio.

$$\begin{aligned}\tan 62^\circ &= \frac{25}{BC} \\ BC &= \frac{25}{\tan 62^\circ} \\ BC &\approx 13.30\end{aligned}$$

$m\angle A$: Use Triangle Sum Theorem

$$\begin{aligned}62^\circ + 90^\circ + m\angle A &= 180^\circ \\ m\angle A &= 28^\circ\end{aligned}$$

2. Even though, there are no angle measures given, we know that the two acute angles are congruent, making them both 45° . Therefore, this is a 45-45-90 triangle. You can use the trigonometric ratios or the special right triangle ratios.

Trigonometric Ratios

$$\tan 45^\circ = \frac{15}{BC}$$

$$BC = \frac{15}{\tan 45^\circ} = 15$$

$$\sin 45^\circ = \frac{15}{AC}$$

$$AC = \frac{15}{\sin 45^\circ} \approx 21.21$$

45-45-90 Triangle Ratios

$$BC = AB = 15, AC = 15\sqrt{2} \approx 21.21$$

Practice

Use your calculator to find $m\angle A$ to the nearest tenth of a degree.

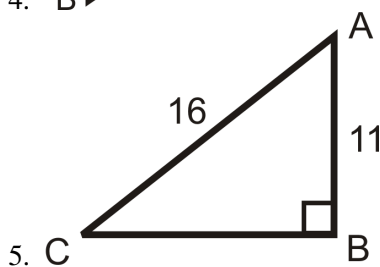
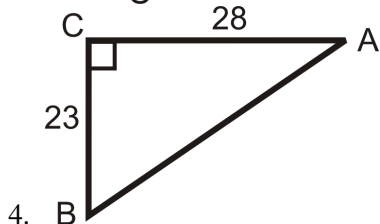
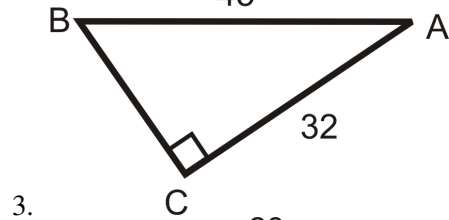
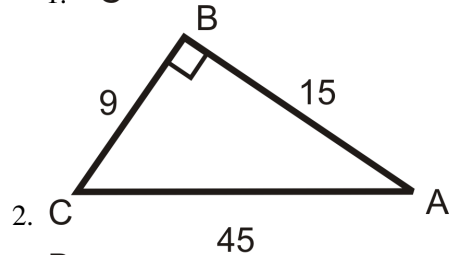
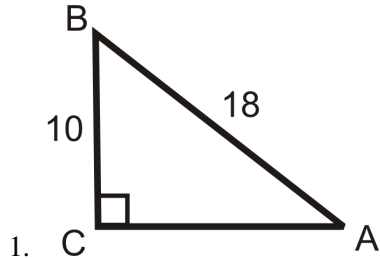

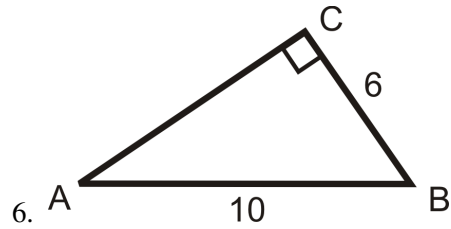

Let $\angle A$ be an acute angle in a right triangle. Find $m\angle A$ to the nearest tenth of a degree.

7. $\sin A = 0.5684$

8. $\cos A = 0.1234$

9. $\tan A = 2.78$

Solve the following right triangles. Find all missing sides and angles.

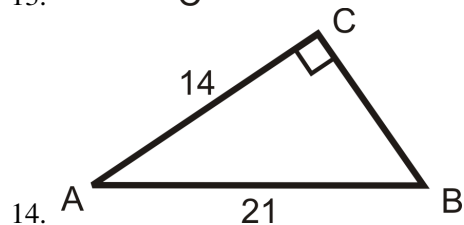
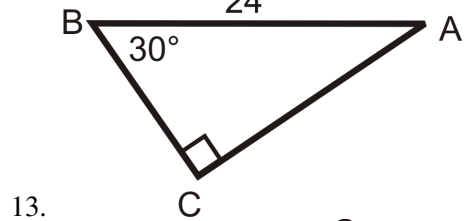
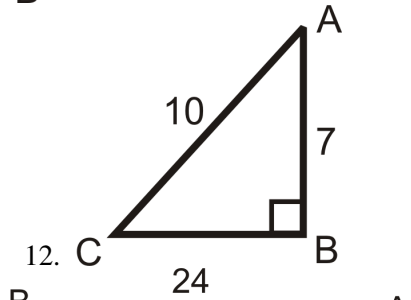
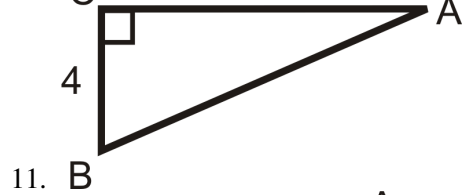
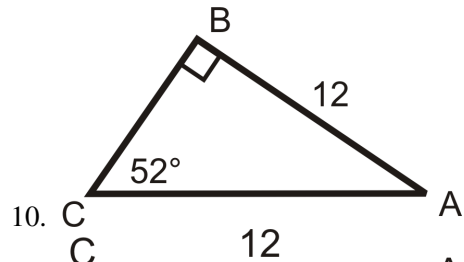

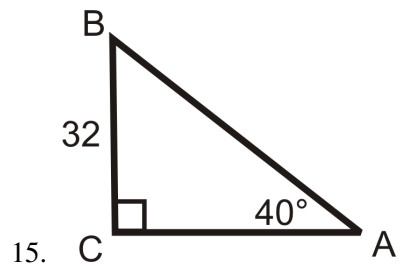

15. C
16. **Writing** Explain when to use a trigonometric ratio to find a side length of a right triangle and when to use the Pythagorean Theorem.

8.10 Laws of Sines and Cosines

Here you'll learn how to solve for missing sides and angles in non-right triangles using the Laws of Sines and Cosines.

What if you wanted to solve for a missing side in a non-right triangle? How could you use trigonometry to help you? After completing this Concept, you'll be able to use the Law of Sines and the Law of Cosines to answer questions like these.

Watch This



MEDIA

Click image to the left for more content.

CK-12 Foundation: Chapter8LawsOfSinesandCosinesA

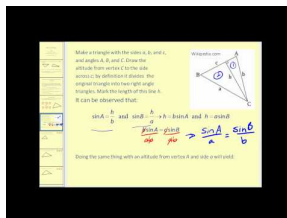

MEDIA

Click image to the left for more content.

James Sousa: The Law of Sines

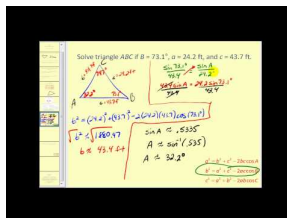

MEDIA

Click image to the left for more content.

James Sousa: The Law of Cosines

Guidance

Law of Sines: If $\triangle ABC$ has sides of length, a , b , and c , then $\frac{\sin A}{a} = \frac{\sin B}{b} = \frac{\sin C}{c}$.

Looking at a triangle, the lengths a , b , and c are opposite the angles of the same letter.

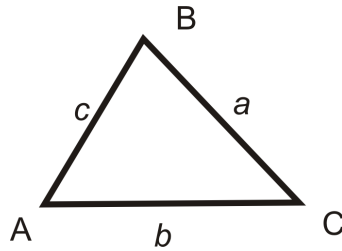

Use Law of Sines when given:

- An angle and its opposite side.
- Any two angles and one side.
- Two sides and the non-included angle.

Law of Cosines: If $\triangle ABC$ has sides of length $a, b,$ and $c,$ then:

$$a^2 = b^2 + c^2 - 2bc \cos A$$

$$b^2 = a^2 + c^2 - 2ac \cos B$$

$$c^2 = a^2 + b^2 - 2ab \cos C$$

Even though there are three formulas, they are all very similar. First, notice that whatever angle is in the cosine, the opposite side is on the other side of the equal sign.

Use Law of Cosines when given:

- Two sides and the included angle.
- All three sides.

Example A

Solve the triangle using the Law of Sines. Round decimal answers to the nearest tenth.

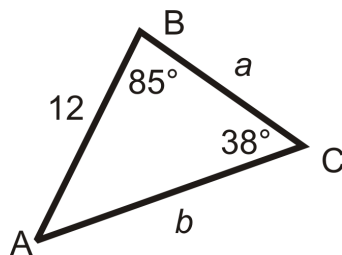

First, to find $m\angle A,$ we can use the Triangle Sum Theorem.

$$m\angle A + 85^\circ + 38^\circ = 180^\circ$$

$$m\angle A = 57^\circ$$

Now, use the Law of Sines to set up ratios for a and $b.$

$$\frac{\sin 57^\circ}{a} = \frac{\sin 85^\circ}{b} = \frac{\sin 38^\circ}{12}$$

$$\frac{\sin 57^\circ}{a} = \frac{\sin 38^\circ}{12}$$

$$a \cdot \sin 38^\circ = 12 \cdot \sin 57^\circ$$

$$a = \frac{12 \cdot \sin 57^\circ}{\sin 38^\circ} \approx 16.4$$

$$\frac{\sin 85^\circ}{b} = \frac{\sin 38^\circ}{12}$$

$$b \cdot \sin 38^\circ = 12 \cdot \sin 85^\circ$$

$$b = \frac{12 \cdot \sin 85^\circ}{\sin 38^\circ} \approx 19.4$$

Example B

Solve the triangle using the Law of Sines. Round decimal answers to the nearest tenth.

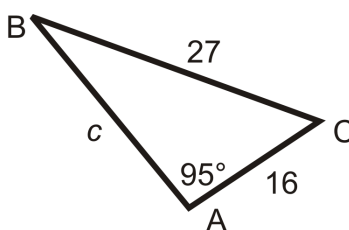

Set up the ratio for $\angle B$ using Law of Sines.

$$\frac{\sin 95^\circ}{27} = \frac{\sin B}{16}$$

$$27 \cdot \sin B = 16 \cdot \sin 95^\circ$$

$$\sin B = \frac{16 \cdot \sin 95^\circ}{27} \rightarrow \sin^{-1} \left(\frac{16 \cdot \sin 95^\circ}{27} \right) = 36.2^\circ$$

To find $m\angle C$ use the Triangle Sum Theorem. $m\angle C + 95^\circ + 36.2^\circ = 180^\circ \rightarrow m\angle C = 48.8^\circ$

To find c , use the Law of Sines again. $\frac{\sin 95^\circ}{27} = \frac{\sin 48.8^\circ}{c}$

$$c \cdot \sin 95^\circ = 27 \cdot \sin 48.8^\circ$$

$$c = \frac{27 \cdot \sin 48.8^\circ}{\sin 95^\circ} \approx 20.4$$

Example C

Solve the triangle using Law of Cosines. Round your answers to the nearest hundredth.

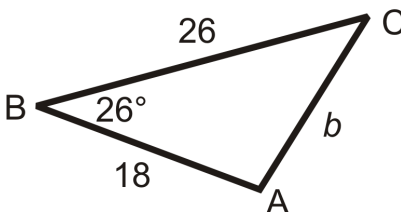

Use the second equation to solve for $\angle B$.

$$b^2 = 26^2 + 18^2 - 2(26)(18)\cos 26^\circ$$

$$b^2 = 1000 - 936\cos 26^\circ$$

$$b^2 = 158.7288$$

$$b \approx 12.60$$

To find $m\angle A$ or $m\angle C$, you can use either the Law of Sines or Law of Cosines. Let's use the Law of Sines.

$$\frac{\sin 26^\circ}{12.60} = \frac{\sin A}{18}$$

$$12.60 \cdot \sin A = 18 \cdot \sin 26^\circ$$

$$\sin A = \frac{18 \cdot \sin 26^\circ}{12.60}$$

$\sin^{-1}\left(\frac{18 \cdot \sin 26^\circ}{12.60}\right) \approx 38.77^\circ$ To find $m\angle C$, use the Triangle Sum Theorem.

$$26^\circ + 38.77^\circ + m\angle C = 180^\circ$$

$$m\angle C = 115.23^\circ$$

Watch this video for help with the Examples above.



MEDIA

Click image to the left for more content.

[CK-12 Foundation: Chapter8LawsOfSinesandCosinesB](#)

Vocabulary

The **Law of Sines** says $\frac{\sin A}{a} = \frac{\sin B}{b} = \frac{\sin C}{c}$ for any triangle (including non-right triangles). The **Law of Cosines** says $a^2 = b^2 + c^2 - 2bc \cos A$ for any triangle.

Guided Practice

Find the following angles in the triangle below. Round your answers to the nearest hundredth.

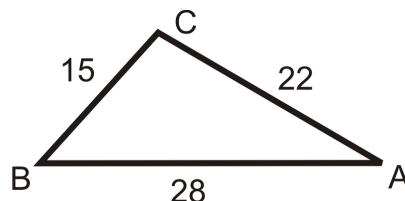

- $m\angle A$
- $m\angle B$
- $m\angle C$

Answers:

1. When you are given only the sides, you have to use the Law of Cosines to find one angle and then you can use the Law of Sines to find another.

$$\begin{aligned} 15^2 &= 22^2 + 28^2 - 2(22)(28)\cos A \\ 225 &= 1268 - 1232\cos A \\ -1043 &= -1232\cos A \\ \frac{-1043}{-1232} &= \cos A \rightarrow \cos^{-1}\left(\frac{1043}{1232}\right) \approx 32.16^\circ \end{aligned}$$

2. Now that we have an angle and its opposite side, we can use the Law of Sines.

$$\begin{aligned} \frac{\sin 32.16^\circ}{15} &= \frac{\sin B}{22} \\ 15 \cdot \sin B &= 22 \cdot \sin 32.16^\circ \\ \sin B &= \frac{22 \cdot \sin 32.16^\circ}{15} \end{aligned}$$

$$\sin^{-1}\left(\frac{22 \cdot \sin 32.16^\circ}{15}\right) \approx 51.32^\circ.$$

3. To find $m\angle C$, use the Triangle Sum Theorem.

$$\begin{aligned} 32.16^\circ + 51.32^\circ + m\angle C &= 180^\circ \\ m\angle C &= 96.52^\circ \end{aligned}$$

Practice

Use the Law of Sines or Cosines to solve $\triangle ABC$. If you are not given a picture, draw one. Round all decimal answers to the nearest tenth.

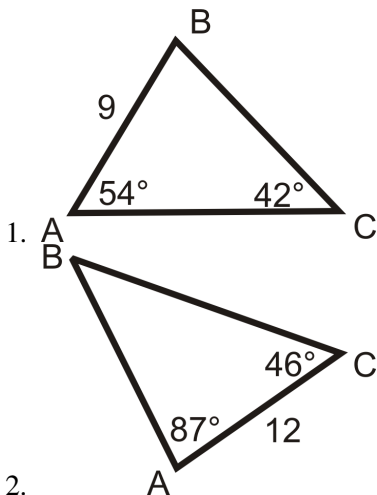

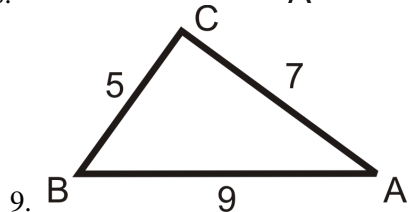
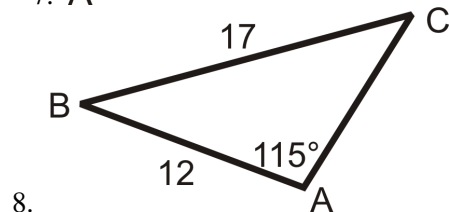
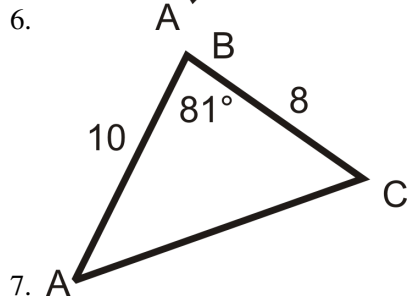
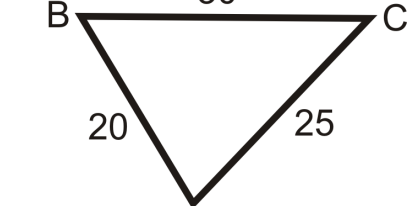
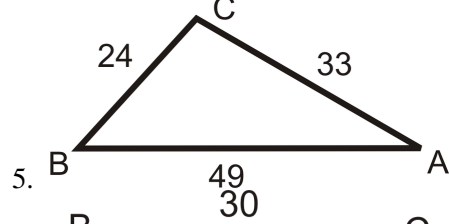
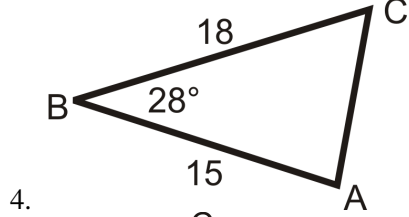
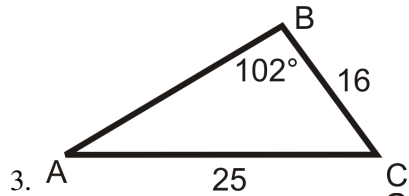

10. $m\angle A = 74^\circ, m\angle B = 11^\circ, BC = 16$
 11. $m\angle A = 64^\circ, AB = 29, AC = 34$
 12. $m\angle C = 133^\circ, m\angle B = 25^\circ, AB = 48$

Use the Law of Sines to solve $\triangle ABC$ below.

13. $m\angle A = 20^\circ, AB = 12, BC = 5$

Recall that when we learned how to prove that triangles were congruent we determined that SSA (two sides and an angle not included) did not determine a unique triangle. When we are using the Law of Sines to solve a triangle and we are given two sides and the angle not included, we may have two possible triangles. Problem 14 illustrates this.

14. Let's say we have $\triangle ABC$ as we did in problem 13. In problem 13 you were given two sides and the not included angle. This time, you have two angles and the side between them (ASA). Solve the triangle given that $m\angle A = 20^\circ$, $m\angle C = 125^\circ$, $AC = 8.4$
15. Does the triangle that you found in problem 14 meet the requirements of the given information in problem 13? How are the two different $m\angle C$ related? Draw the two possible triangles overlapping to visualize this relationship.

Summary

This chapter begins with the Pythagorean Theorem, its converse, and Pythagorean triples. Applications of the Pythagorean Theorem are explored including finding heights of isosceles triangles, proving the distance formula, and determining whether a triangle is right, acute, or obtuse. The chapter then branches out into special right triangles, 45-45-90 and 30-60-90. Trigonometric ratios, trigonometry word problems, inverse trigonometric ratios, and the Law of Sines and Law of Cosines are explored at the end of this chapter.

Chapter Keywords

- Pythagorean Theorem
- Pythagorean Triple
- Distance Formula
- Pythagorean Theorem Converse
- Geometric Mean
- 45-45-90 Corollary
- 30-60-90 Corollary
- Trigonometry
- Adjacent (Leg)
- Opposite (Leg)
- Sine Ratio
- Cosine Ratio
- Tangent Ratio
- Angle of Depression
- Angle of Elevation
- Inverse Tangent
- Inverse Sine
- Inverse Cosine
- Law of Sines
- Law of Cosines

Chapter Review

Solve the following right triangles using the Pythagorean Theorem, the trigonometric ratios, and the inverse trigonometric ratios. When possible, simplify the radical. If not, round all decimal answers to the nearest tenth.

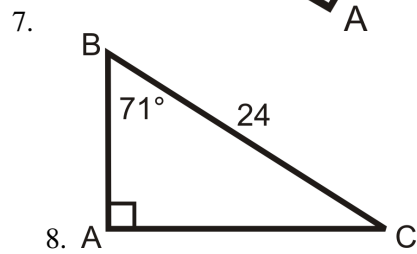
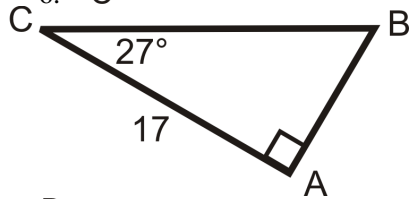
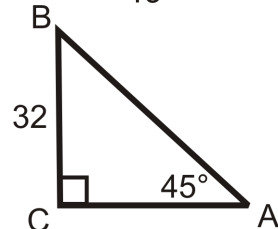
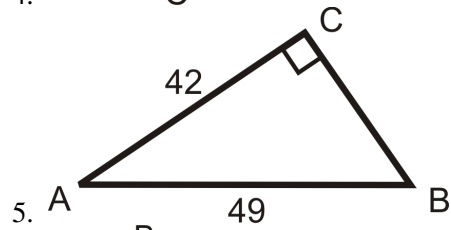
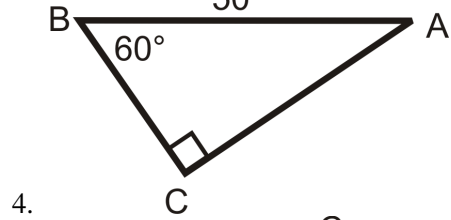
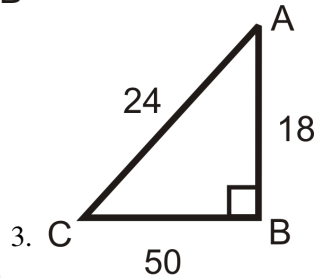
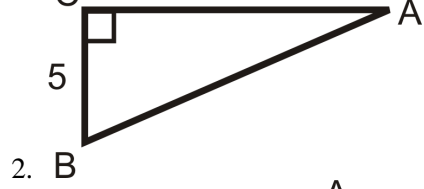
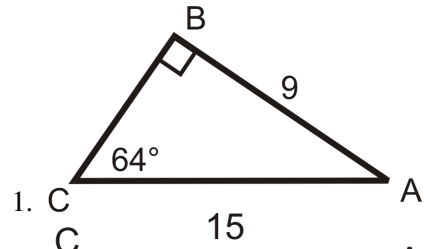

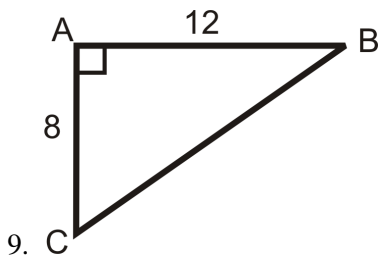

Determine if the following lengths make an acute, right, or obtuse triangle. If they make a right triangle, determine if the lengths are a Pythagorean triple.

- 10. 11, 12, 13
- 11. 16, 30, 34
- 12. 20, 25, 42
- 13. $10\sqrt{6}, 30, 10\sqrt{15}$
- 14. 22, 25, 31
- 15. 47, 27, 35

Find the value of x .

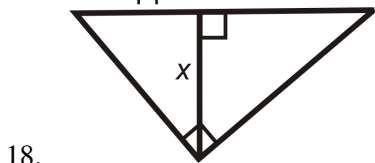
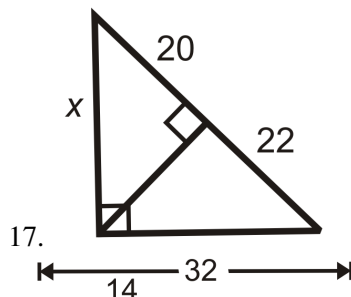
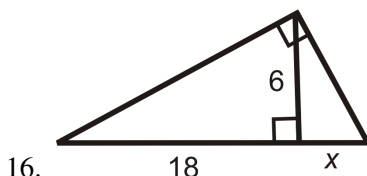

- 19. The angle of elevation from the base of a mountain to its peak is 76° . If its height is 2500 feet, what is the distance a person would climb to reach the top? Round your answer to the nearest tenth.
- 20. Taylor is taking an aerial tour of San Francisco in a helicopter. He spots ATT Park (baseball stadium) at a horizontal distance of 850 feet and down (vertical) 475 feet. What is the angle of depression from the helicopter to the park? Round your answer to the nearest tenth.

Use the Law of Sines and Cosines to solve the following triangles. Round your answers to the nearest tenth.

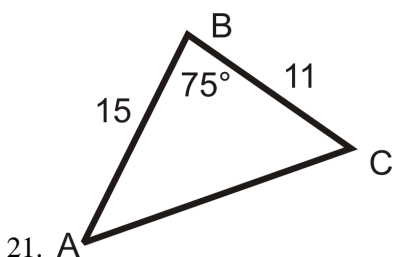

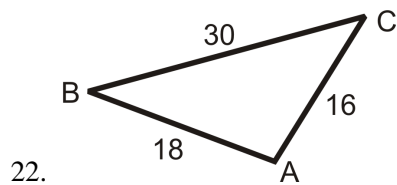

Texas Instruments Resources

In the CK-12 Texas Instruments Geometry FlexBook, there are graphing calculator activities designed to supplement the objectives for some of the lessons in this chapter. See <http://www.ck12.org/flexr/chapter/9693>.

CHAPTER 9**Circles****Chapter Outline**

- 9.1 PARTS OF CIRCLES**
 - 9.2 TANGENT LINES**
 - 9.3 ARCS IN CIRCLES**
 - 9.4 CHORDS IN CIRCLES**
 - 9.5 INSCRIBED ANGLES IN CIRCLES**
 - 9.6 INSCRIBED QUADRILATERALS IN CIRCLES**
 - 9.7 ANGLES ON AND INSIDE A CIRCLE**
 - 9.8 ANGLES OUTSIDE A CIRCLE**
 - 9.9 SEGMENTS FROM CHORDS**
 - 9.10 SEGMENTS FROM SECANTS**
 - 9.11 SEGMENTS FROM SECANTS AND TANGENTS**
 - 9.12 CIRCLES IN THE COORDINATE PLANE**
-

Introduction

Finally, we dive into a different shape, circles. First, we will define all the parts of circles and then explore the properties of tangent lines, arcs, inscribed angles, and chords. Next, we will learn about the properties of angles within circles that are formed by chords, tangents and secants. Lastly, we will place circles in the coordinate plane, find the equations of, and graph circles.

9.1 Parts of Circles

Here you'll learn the vocabulary associated with the parts of circles.

What if you were asked to geometrically consider the ancient astronomical clock in Prague, pictured below? It has a large background circle that tells the local time and the “ancient time” and then the smaller circle rotates around on the orange line to show the current astrological sign. The yellow point is the center of the larger clock. How does the orange line relate to the small and larger circle? How does the hand with the moon on it (black hand with the circle) relate to both circles? Are the circles concentric or tangent? After completing this Concept, you'll be able to use your knowledge of parts of circles to answer questions like these.



For more information on this clock, see: http://en.wikipedia.org/wiki/Prague_Astronomical_Clock

Watch This



MEDIA

Click image to the left for more content.

CK-12 Foundation: Chapter9PartsofCirclesA

Watch the first half of this video.

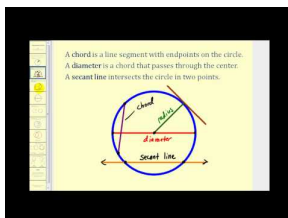

MEDIA

Click image to the left for more content.

James Sousa:Introduction toCircles

Guidance

A **circle** is the set of all points in the plane that are the same distance away from a specific point, called the **center**. The center of the circle below is point *A*. We call this circle “circle *A*,” and it is labeled $\odot A$.

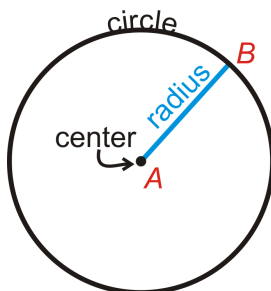

Important Circle Parts

Radius: The distance from the center of the circle to its outer rim.

Chord: A line segment whose endpoints are on a circle.

Diameter: A chord that passes through the center of the circle. The length of a diameter is two times the length of a radius.

Secant: A line that intersects a circle in two points.

Tangent: A line that intersects a circle in exactly one point.

Point of Tangency: The point where a tangent line touches the circle.

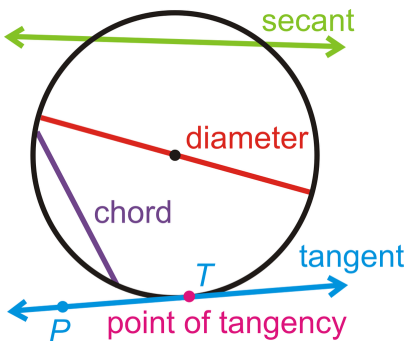

The tangent ray \overrightarrow{TP} and tangent segment \overline{TP} are also called tangents.

Tangent Circles: Two or more circles that intersect at one point.

Two circles can be tangent to each other in two different ways, either *internally* tangent or *externally* tangent.

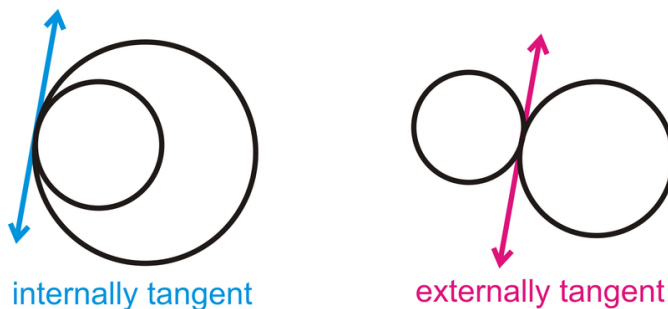

If the circles are not tangent, they can share a tangent line, called a *common tangent*. Common tangents can be internally tangent and externally tangent too. Notice that the common internal tangent passes through the space between the two circles. Common external tangents stay on the top or bottom of both circles.

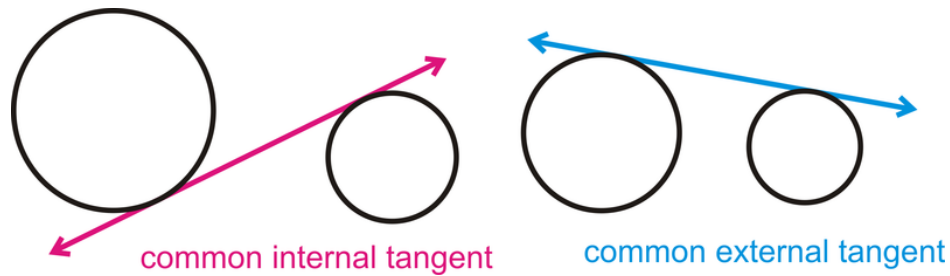

Concentric Circles: Two or more circles that have the same center, but different radii.

Congruent Circles: Two or more circles with the same radius, but different centers.

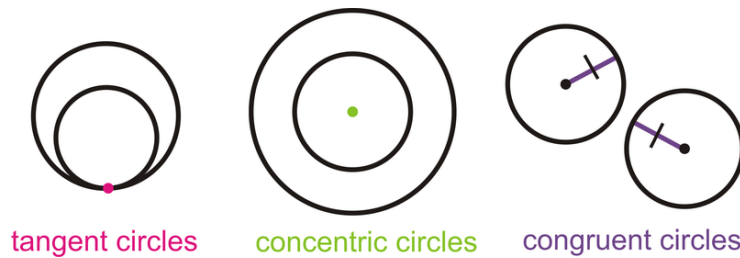

Example A

Find the parts of $\odot A$ that best fit each description.

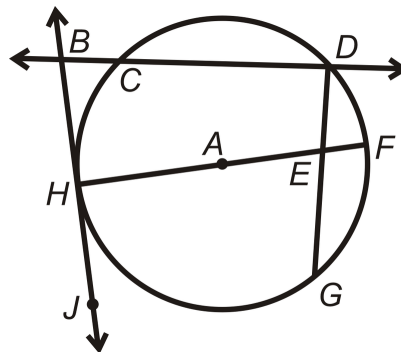

- A radius
- A chord
- A tangent line
- A point of tangency
- A diameter
- A secant

Answers:

- \overline{HA} or \overline{AF}

b) \overline{CD} , \overline{HF} , or \overline{DG} c) \overleftrightarrow{BJ} d) *Point H*e) \overline{HF} f) \overleftrightarrow{BD} **Example B**

Draw an example of how two circles can intersect with no, one and two points of intersection. You will make three separate drawings.

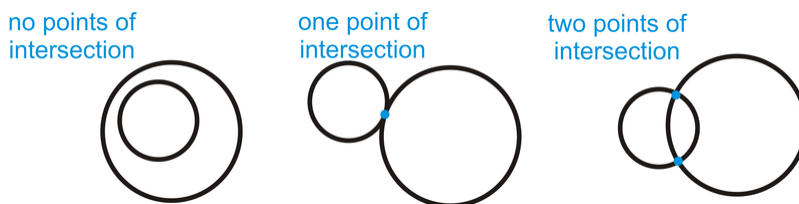
**Example C**

Determine if any of the following circles are congruent.

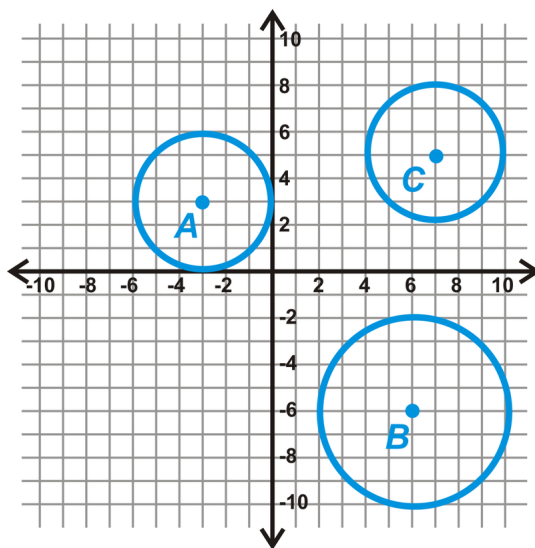

From each center, count the units to the outer rim of the circle. It is easiest to count vertically or horizontally. Doing this, we have:

Radius of $\odot A = 3$ units

Radius of $\odot B = 4$ units

Radius of $\odot C = 3$ units

From these measurements, we see that $\odot A \cong \odot C$.

Notice the *circles are congruent*. The *lengths of the radii* are *equal*.

Watch this for help with the Examples above.



MEDIA

Click image to the left for more content.

[CK-12 Foundation: Chapter9PartsofCirclesB](#)

Concept Problem Revisited

Refer to the photograph in the “Concept” section at the beginning of this Concept. The orange line (which is normally black, but outlined for the purpose of this exercise) is a diameter of the smaller circle. Since this line passes through the center of the larger circle (yellow point, also outlined), it is part of one of its diameters. The “moon” hand is a diameter of the larger circle, but a secant of the smaller circle. The circles are not concentric because they do not have the same center and are not tangent because the sides of the circles do not touch.

Vocabulary

A *circle* is the set of all points that are the same distance away from a specific point, called the *center*. A *radius* is the distance from the center to the outer rim of a circle. A *chord* is a line segment whose endpoints are on a circle. A *diameter* is a chord that passes through the center of the circle. The length of a diameter is two times the length of a radius. A *secant* is a line that intersects a circle in two points. A *tangent* is a line that intersects a circle in exactly one point. The *point of tangency* is the point where the tangent line touches the circle. *Tangent circles* are two or more circles that intersect at one point. *Concentric circles* are two or more circles that have the same center, but different radii. *Congruent circles* are two or more circles with the same radius, but different centers.

Guided Practice

1. If the diameter of a circle is 10 inches, how long is the radius?
2. Is it possible to have a line that intersects a circle three times? If so, draw one. If not, explain.
3. Are all circles similar?

Answers:

1. The radius is always half the length of the diameter, so it is 5 inches.
2. It is not possible. By definition, all lines are *straight*. The maximum number of times a line can intersect a circle is twice.
3. Yes. All circles are the same shape, but not necessarily the same size, so they are similar.

Practice

Determine which term best describes each of the following parts of $\odot P$.

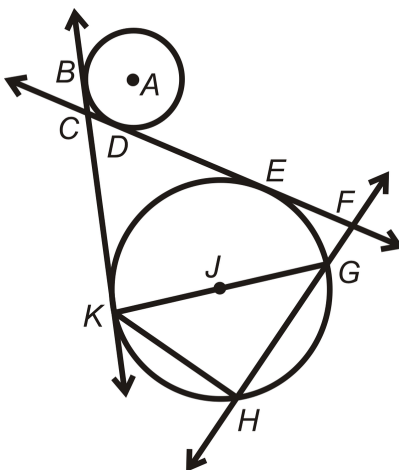

1. \overline{KG}
2. \overline{FH}
3. \overline{KH}
4. \overline{E}
5. \overline{BK}
6. \overline{CF}
7. A
8. \overline{JG}
9. \overline{HG}
10. What is the longest chord in any circle?

Use the graph below to answer the following questions.

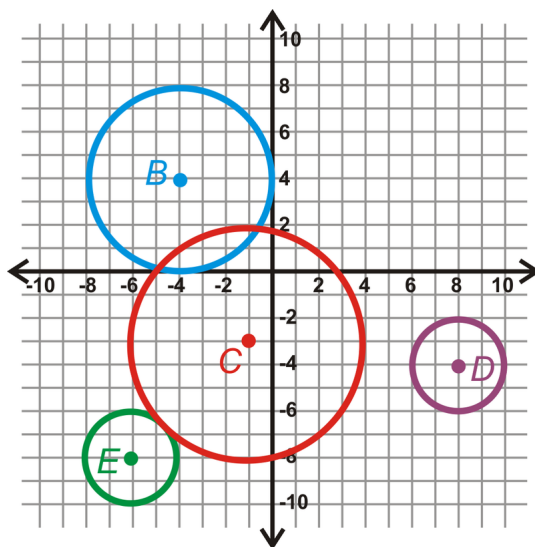

11. Find the radius of each circle.
12. Are any circles congruent? How do you know?
13. How are $\odot C$ and $\odot E$ related?
14. Find the equation of \overline{CE} .
15. Find the length of \overline{CE} .

9.2 Tangent Lines

Here you'll learn two theorems about tangent lines and how to apply them.

What if a line were drawn outside a circle that appeared to touch the circle at only one point? How could you determine if that line were actually a tangent? After completing this Concept, you'll be able to apply theorems to solve tangent problems like this one.

Watch This



MEDIA

Click image to the left for more content.

CK-12 Foundation: Chapter9TangentLinesA

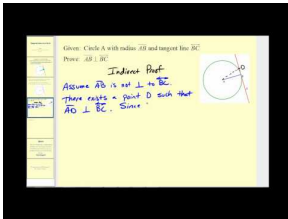

MEDIA

Click image to the left for more content.

James Sousa:TangentLines to a Circle

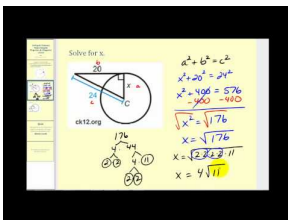

MEDIA

Click image to the left for more content.

James Sousa:TangentLines to a Circle Example Problems

Guidance

The tangent line and the radius drawn to the point of tangency have a unique relationship. Let's investigate it here.

Investigation: Tangent Line and Radius Property

Tools needed: compass, ruler, pencil, paper, protractor

- Using your compass, draw a circle. Locate the center and draw a radius. Label the radius \overline{AB} , with A as the center.

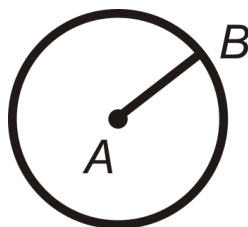

- Draw a tangent line, \overleftrightarrow{BC} , where B is the point of tangency. To draw a tangent line, take your ruler and line it up with point B . Make sure that B is the only point on the circle that the line passes through.

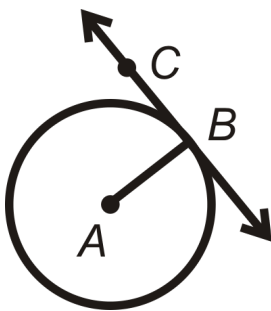

- Using your protractor, find $m\angle ABC$.

Tangent to a Circle Theorem: A line is tangent to a circle if and only if the line is perpendicular to the radius drawn to the point of tangency.

To prove this theorem, the easiest way to do so is indirectly (proof by contradiction). Also, notice that this theorem uses the words “if and only if,” making it a biconditional statement. Therefore, the converse of this theorem is also true. Now let’s look at two tangent segments, drawn from the same external point. If we were to measure these two segments, we would find that they are equal.

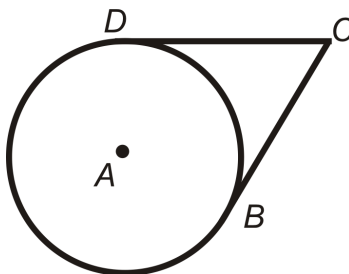

Two Tangents Theorem: If two tangent segments are drawn from the same external point, then the segments are equal.

Example A

In $\odot A$, \overline{CB} is tangent at point B . Find AC . Reduce any radicals.

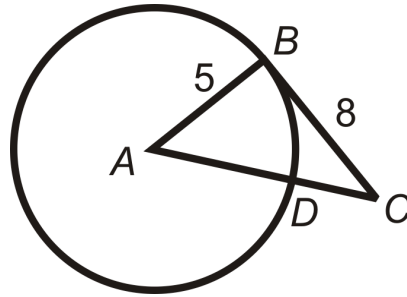

Solution: Because \overline{CB} is tangent, $\overline{AB} \perp \overline{CB}$, making $\triangle ABC$ a right triangle. We can use the Pythagorean Theorem to find AC .

$$\begin{aligned} 5^2 + 8^2 &= AC^2 \\ 25 + 64 &= AC^2 \\ 89 &= AC^2 \\ AC &= \sqrt{89} \end{aligned}$$

Example B

Find DC , in $\odot A$. Round your answer to the nearest hundredth.

Solution:

$$\begin{aligned} DC &= AC - AD \\ DC &= \sqrt{89} - 5 \approx 4.43 \end{aligned}$$

Example C

Find the perimeter of $\triangle ABC$.

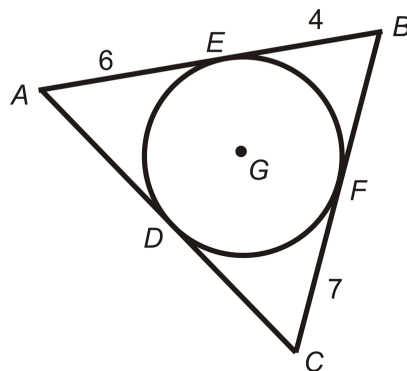

Solution: $AE = AD$, $EB = BF$, and $CF = CD$. Therefore, the perimeter of $\triangle ABC = 6 + 6 + 4 + 4 + 7 + 7 = 34$.

We say that $\odot G$ is *inscribed* in $\triangle ABC$. A circle is inscribed in a polygon, if every side of the polygon is tangent to the circle.

Example D

Find the value of x .

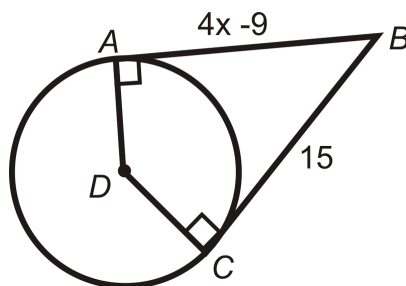

Because $\overline{AB} \perp \overline{AD}$ and $\overline{DC} \perp \overline{CB}$, \overline{AB} and \overline{CB} are tangent to the circle and also congruent. Set $AB = CB$ and solve for x .

$$4x - 9 = 15$$

$$4x = 24$$

$$x = 6$$

Watch this video for help with the Examples above.



MEDIA

Click image to the left for more content.

[CK-12 Foundation: Chapter9TangentLinesB](#)

Vocabulary

A **circle** is the set of all points that are the same distance away from a specific point, called the **center**. A **radius** is the distance from the center to the outer rim of a circle. A **diameter** is a chord that passes through the center of the circle. The length of a diameter is two times the length of a radius. A **tangent** is a line that intersects a circle in exactly one point. The **point of tangency** is the point where the tangent line touches the circle.

Guided Practice

1. Determine if the triangle below is a right triangle. Explain why or why not.

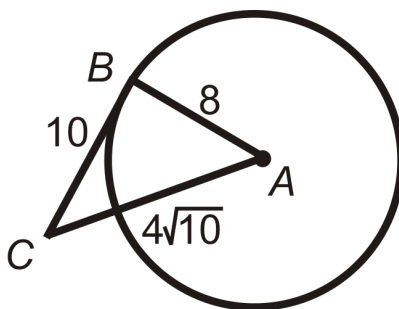

2. Find the distance between the centers of the two circles. Reduce all radicals.

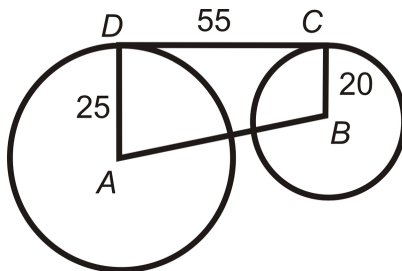

3. If D and A are the centers and AE is tangent to both circles, find DC .

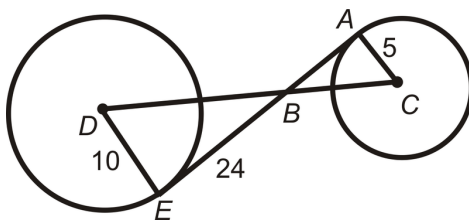

Answers:

1. To determine if the triangle is a right triangle, use the Pythagorean Theorem. $4\sqrt{10}$ is the longest length, so we will set it equal to c in the formula.

$$8^2 + 10^2 \stackrel{?}{=} (4\sqrt{10})^2$$

$$64 + 100 \neq 160$$

$\triangle ABC$ is not a right triangle. And, from the converse of the Tangent to a Circle Theorem, \overline{CB} is not tangent to $\odot A$.

2. The distance between the two circles is AB . They are not tangent, however, $\overline{AD} \perp \overline{DC}$ and $\overline{DC} \perp \overline{CB}$. Let's add \overline{BE} , such that $EDCB$ is a rectangle. Then, use the Pythagorean Theorem to find AB .

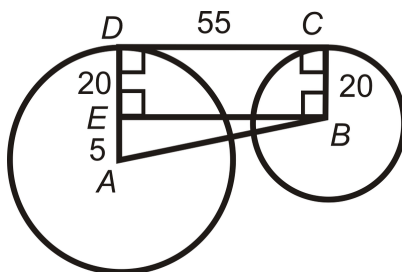

$$5^2 + 55^2 = AC^2$$

$$25 + 3025 = AC^2$$

$$3050 = AC^2$$

$$AC = \sqrt{3050} = 5\sqrt{122}$$

3. Because AE is tangent to both circles, it is perpendicular to both radii and $\triangle ABC$ and $\triangle DBE$ are similar. To find DB , use the Pythagorean Theorem.

$$10^2 + 24^2 = DB^2$$

$$100 + 576 = 676$$

$$DB = \sqrt{676} = 26$$

To find BC , use similar triangles.

$$\frac{5}{10} = \frac{BC}{26} \rightarrow BC = 13$$

$$DC = AB + BC = 26 + 13 = 39$$

Practice

Determine whether the given segment is tangent to $\odot K$.

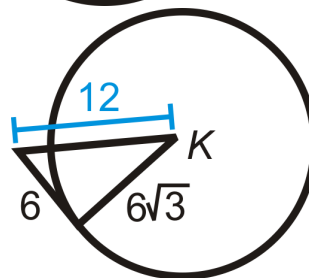
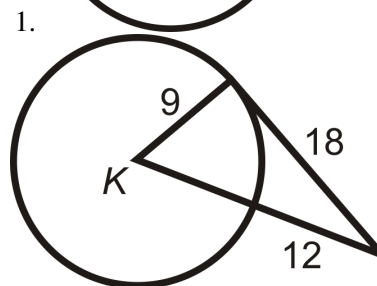
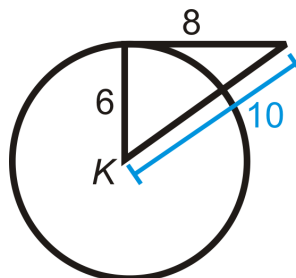

Algebra Connection Find the value of the indicated length(s) in $\odot C$. A and B are points of tangency. Simplify all radicals.

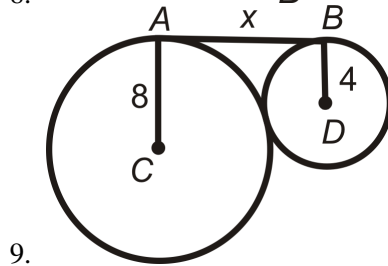
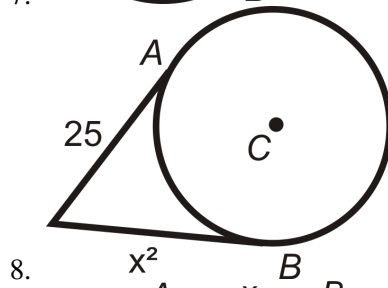
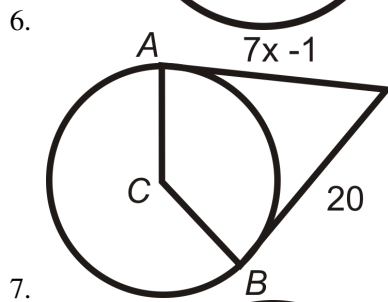
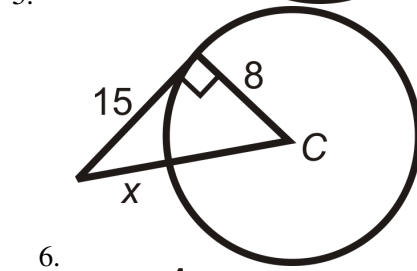
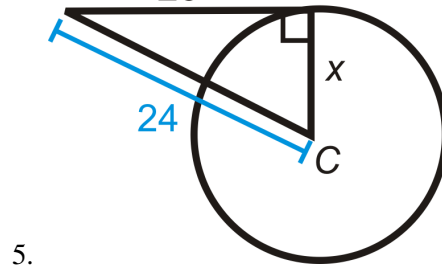
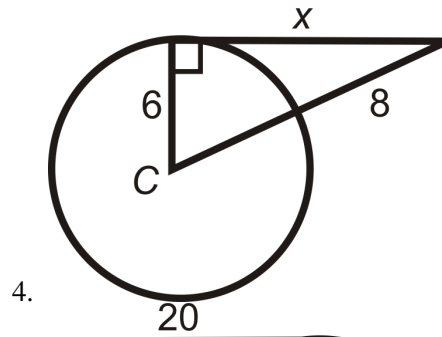

10. A and B are points of tangency for $\odot C$ and $\odot D$, respectively.

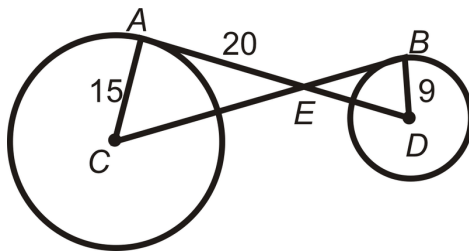

- a. Is $\triangle AEC \sim \triangle BED$? Why?
- b. Find BC .
- c. Find AD .
- d. Using the trigonometric ratios, find $m\angle C$. Round to the nearest tenth of a degree.

11. Fill in the blanks in the proof of the Two Tangents Theorem. Given: \overline{AB} and \overline{CB} with points of tangency at A and C. \overline{AD} and \overline{DC} are radii. Prove: $\overline{AB} \cong \overline{CB}$

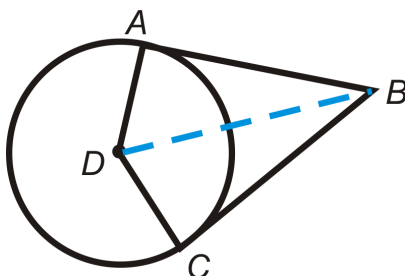

TABLE 9.1:

Statement

Reason

| | |
|--|-----------------------------------|
| 1. | |
| 2. $\overline{AD} \cong \overline{DC}$ | |
| 3. $\overline{DA} \perp \overline{AB}$ and $\overline{DC} \perp \overline{CB}$ | |
| 4. | Definition of perpendicular lines |
| 5. | Connecting two existing points |
| 6. $\triangle ADB$ and $\triangle DCB$ are right triangles | |
| 7. $\overline{DB} \cong \overline{DB}$ | |
| 8. $\triangle ABD \cong \triangle CBD$ | |
| 9. $\overline{AB} \cong \overline{CB}$ | |

12. From the above proof, we can also conclude (fill in the blanks):

- a. $ABCD$ is a _____ (type of quadrilateral).
- b. The line that connects the _____ and the external point B _____ $\angle ADC$ and $\angle ABC$.

13. Points A, B, C, and D are all points of tangency for the three tangent circles. Explain why $\overline{AT} \cong \overline{BT} \cong \overline{CT} \cong \overline{DT}$.

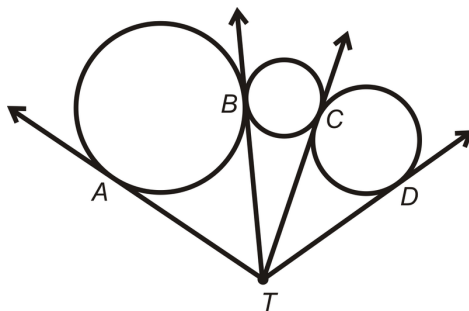

14. Circles tangent at T are centered at M and N . \overline{ST} is tangent to both circles at T . Find the radius of the smaller circle if $\overline{SN} \perp \overline{SM}$, $SM = 22$, $TN = 25$ and $m\angle SNT = 40^\circ$.

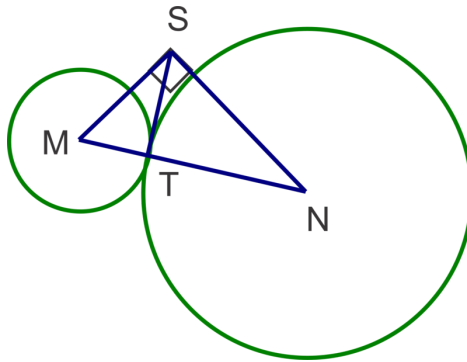

15. Four circles are arranged inside an equilateral triangle as shown. If the triangle has sides equal to 16 cm, what is the radius of the bigger circle?

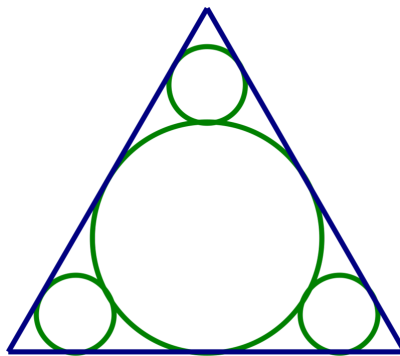

16. Circles centered at A and B are tangent at W . Explain why A, B and W are collinear.

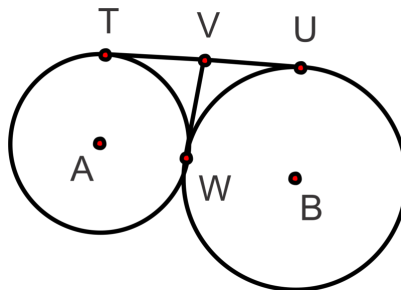

9.3 Arcs in Circles

Here you'll learn the properties of arcs and central angles of circles and how to apply them.

What if the Ferris wheel below had equally spaced seats, such that the central angle were 20° . How many seats are there? Why do you think it is important to have equally spaced seats on a Ferris wheel?



If the radius of this Ferris wheel is 25 ft., how far apart are two adjacent seats? Round your answer to the nearest tenth. *The shortest distance between two points is a straight line.* After completing this Concept, you'll be able to answer questions like these.

Watch This



MEDIA

Click image to the left for more content.

[CK-12 Foundation: Chapter9ArcsinCirclesA](#)

[Learn more about central angles by watching the video at this link.](#)

Guidance

A **central angle** is the angle formed by two radii of the circle with its vertex at the center of the circle. In the picture below, the central angle would be $\angle BAC$. Every central angle divides a circle into two **arcs** (an **arc** is a section of the circle). In this case the arcs are \widehat{BC} and \widehat{BDC} . Notice the arc above the letters. To label an arc, always use this curve above the letters. Do not confuse \overline{BC} and \widehat{BC} .

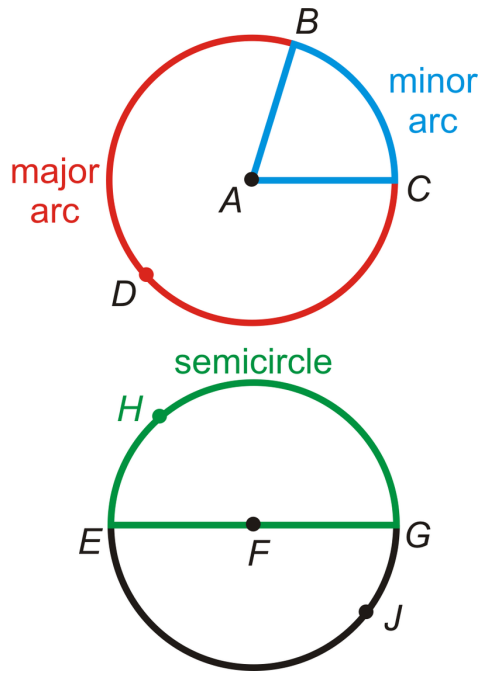

If D was not on the circle, we would not be able to tell the difference between \widehat{BC} and \widehat{BDC} . There are 360° in a circle, where a semicircle is half of a circle, or 180° . $m\angle EFG = 180^\circ$, because it is a straight angle, so $m\widehat{EHG} = 180^\circ$ and $m\widehat{EJJG} = 180^\circ$.

- **Semicircle:** An arc that measures 180° .
- **Minor Arc:** An arc that is less than 180° .
- **Major Arc:** An arc that is greater than 180° . *Always* use 3 letters to label a major arc.

Two arcs are **congruent** if their central angles are congruent. The measure of the arc formed by two adjacent arcs is the sum of the measures of the two arcs (**Arc Addition Postulate**). An arc can be measured in degrees or in a linear measure (cm, ft, etc.). In this chapter we will use degree measure. *The measure of the minor arc is the same as the measure of the central angle* that corresponds to it. The measure of the major arc equals to 360° minus the measure of the minor arc. In order to prevent confusion, major arcs are always named with three letters; the letters that denote the endpoints of the arc and any other point on the major arc. When referring to the measure of an arc, always place an “ m ” in front of the label.

Example A

Find $m\widehat{AB}$ and $m\widehat{ADB}$ in $\odot C$.

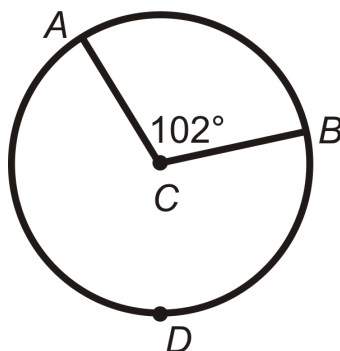

$m\widehat{AB} = m\angle ACB$. So, $m\widehat{AB} = 102^\circ$.

$$m\widehat{ADB} = 360^\circ - m\widehat{AB} = 360^\circ - 102^\circ = 258^\circ$$

Example B

Find the measures of the minor arcs in $\odot A$. \overline{EB} is a diameter.

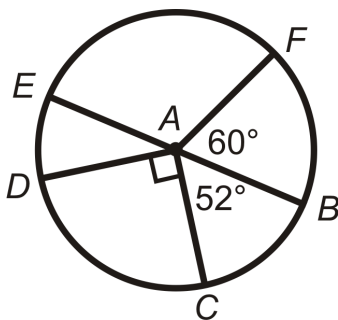

Because \overline{EB} is a diameter, $m\angle EAB = 180^\circ$. Each arc has the same measure as its corresponding central angle.

$$m\widehat{BF} = m\angle FAB = 60^\circ$$

$$m\widehat{EF} = m\angle EAF = 120^\circ \rightarrow 180^\circ - 60^\circ$$

$$m\widehat{ED} = m\angle EAD = 38^\circ \rightarrow 180^\circ - 90^\circ - 52^\circ$$

$$m\widehat{DC} = m\angle DAC = 90^\circ$$

$$m\widehat{BC} = m\angle BAC = 52^\circ$$

Example C

Find the measures of the indicated arcs in $\odot A$. \overline{EB} is a diameter.

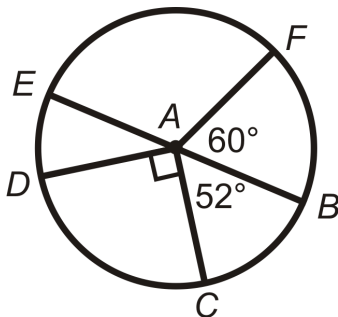

a) $m\widehat{FED}$

b) $m\widehat{CDF}$

c) $m\widehat{DFC}$

Use the Arc Addition Postulate.

$$a) m\widehat{FED} = m\widehat{FE} + m\widehat{ED} = 120^\circ + 38^\circ = 158^\circ$$

$$b) m\widehat{CDF} = m\widehat{CD} + m\widehat{DE} + m\widehat{EF} = 90^\circ + 38^\circ + 120^\circ = 248^\circ$$

$$c) m\widehat{DFC} = m\widehat{ED} + m\widehat{EF} + m\widehat{FB} + m\widehat{BC} = 38^\circ + 120^\circ + 60^\circ + 52^\circ = 270^\circ$$

Watch this video for help with the Examples above.



MEDIA

Click image to the left for more content.

CK-12 Foundation: Chapter9ArcsinCirclesB

Concept Problem Revisited

Because the seats are 20° apart, there will be $\frac{360^\circ}{20^\circ} = 18$ seats. It is important to have the seats evenly spaced for balance. To determine how far apart the adjacent seats are, use the triangle to the right. We will need to use sine to find x and then multiply it by 2.

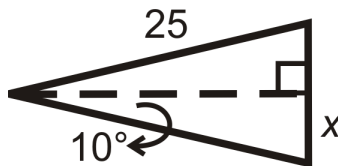

$$\sin 10^\circ = \frac{x}{25}$$

$$x = 25 \sin 10^\circ = 4.3 \text{ ft.}$$

The total distance apart is 8.6 feet.

Vocabulary

A **circle** is the set of all points that are the same distance away from a specific point, called the **center**. An **arc** is a section of the circle. A **semicircle** is an arc that measures 180° . A **central angle** is the angle formed by two radii with its vertex at the center of the circle. A **minor arc** is an arc that is less than 180° . A **major arc** is an arc that is greater than 180° .

Guided Practice

- List the congruent arcs in $\odot C$ below. \overline{AB} and \overline{DE} are diameters.

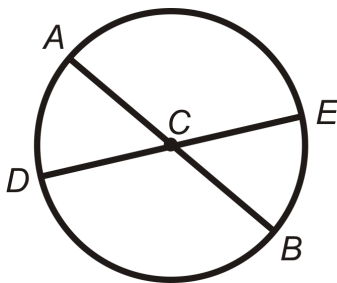

2. Are the blue arcs congruent? Explain why or why not.

a)

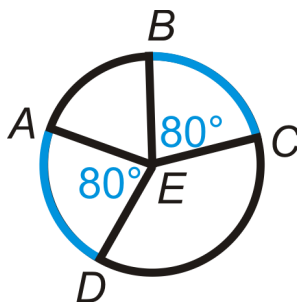

b)

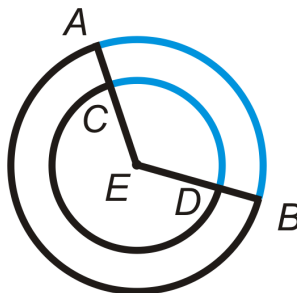

3. Find the value of x for $\odot C$ below.

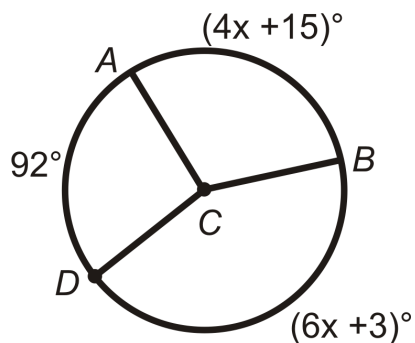

Answers:

1. $\angle ACD \cong \angle ECB$ because they are vertical angles. $\angle DCB \cong \angle ACE$ because they are also vertical angles.

$\widehat{AD} \cong \widehat{EB}$ and $\widehat{AE} \cong \widehat{DB}$

2. a) $\widehat{AD} \cong \widehat{BC}$ because they have the same central angle measure and are in the same circle.

- b) The two arcs have the same measure, but are not congruent because the circles have different radii.
3. The sum of the measure of the arcs is 360° because they make a full circle.

$$\begin{aligned} m\widehat{AB} + m\widehat{AD} + m\widehat{DB} &= 360^\circ \\ (4x + 15)^\circ + 92^\circ + (6x + 3)^\circ &= 360^\circ \\ 10x + 110^\circ &= 360^\circ \\ 10x &= 250 \\ x &= 25 \end{aligned}$$

Practice

Determine if the arcs below are a minor arc, major arc, or semicircle of $\odot G$. \overline{EB} is a diameter.

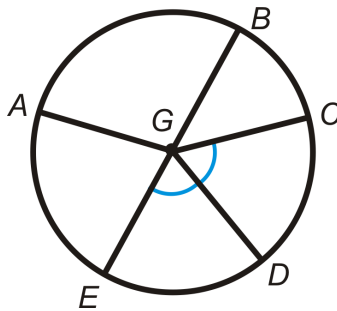

- \widehat{AB}
- \widehat{ABD}
- \widehat{BCE}
- \widehat{CAE}
- \widehat{ABC}
- \widehat{EAB}
- Are there any congruent arcs? If so, list them.
- If $m\widehat{BC} = 48^\circ$, find $m\widehat{CD}$.
- Using #8, find $m\widehat{CAE}$.

Determine if the blue arcs are congruent. If so, state why.

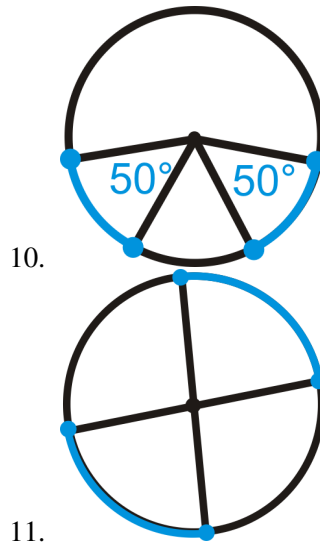

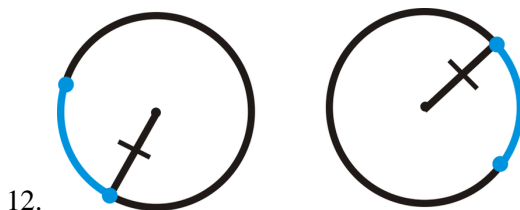

Find the measure of the indicated arcs or central angles in $\odot A$. \overline{DG} is a diameter.

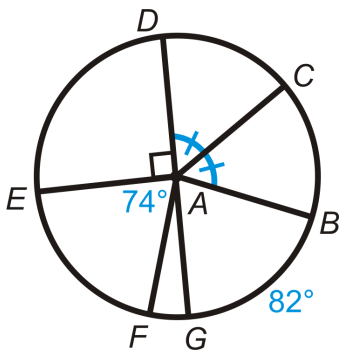

13. \widehat{DE}
14. \widehat{DC}
15. $\angle GAB$
16. \widehat{FG}
17. \widehat{EDB}
18. $\angle EAB$
19. \widehat{DCF}
20. \widehat{DBE}

Algebra Connection Find the measure of x in $\odot P$.

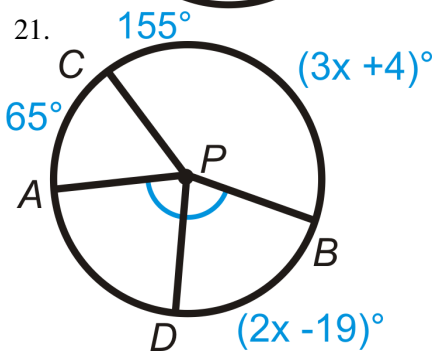
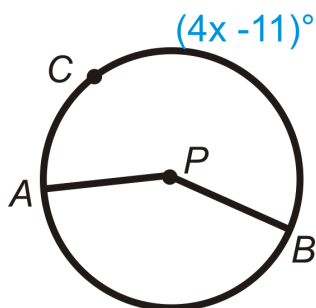

22.

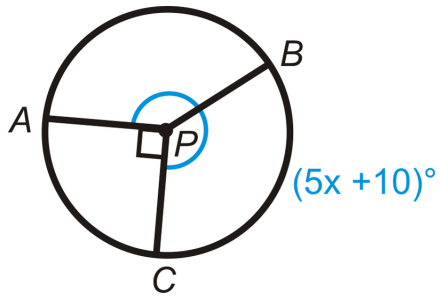

23.

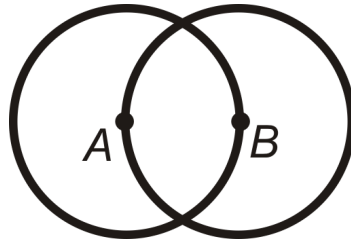
24. What can you conclude about $\odot A$ and $\odot B$?

9.4 Chords in Circles

Here you'll learn theorems about chords in circles and how to apply them.

What if you were asked to geometrically consider the Gran Teatro Falla, in Cadiz, Andalucía, Spain, pictured below? This theater was built in 1905 and hosts several plays and concerts. It is an excellent example of circles in architecture. Notice the five windows, $A - E$. $\odot A \cong \odot E$ and $\odot B \cong \odot C \cong \odot D$. Each window is topped with a 240° arc. The gold chord in each circle connects the rectangular portion of the window to the circle. Which chords are congruent? How do you know? After completing this Concept, you'll be able to use properties of chords to answer questions like these.



Watch This



MEDIA

Click image to the left for more content.

[CK-12 Foundation: Chapter9ChordsinCirclesA](#)

Learn more about chords and a circle's center by watching the video at this link.

Guidance

A **chord** is a line segment whose endpoints are on a circle. A diameter is the longest chord in a circle. There are several theorems that explore the properties of chords.

Chord Theorem #1: In the same circle or congruent circles, minor arcs are congruent if and only if their corresponding chords are congruent.

Notice the “if and only if” in the middle of the theorem. This means that Chord Theorem #1 is a biconditional statement. Taking this theorem one step further, any time two central angles are congruent, the chords and arcs from the endpoints of the sides of the central angles are also congruent. In both of these pictures, $\overline{BE} \cong \overline{CD}$ and $\widehat{BE} \cong \widehat{CD}$. In the second picture, we have $\triangle BAE \cong \triangle CAD$ because the central angles are congruent and $\overline{BA} \cong \overline{AC} \cong \overline{AD} \cong \overline{AE}$ because they are all radii (SAS). By CPCTC, $\overline{BE} \cong \overline{CD}$.

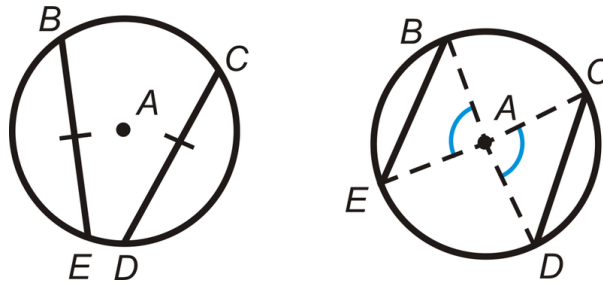

Investigation: Perpendicular Bisector of a Chord

Tools Needed: paper, pencil, compass, ruler

1. Draw a circle. Label the center A .

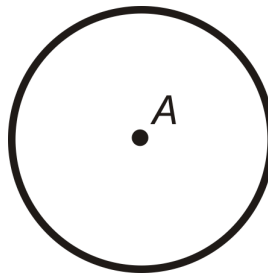

2. Draw a chord in $\odot A$. Label it \overline{BC} .

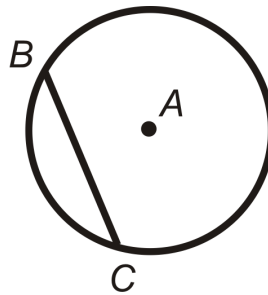

3. Find the midpoint of \overline{BC} by using a ruler. Label it D .

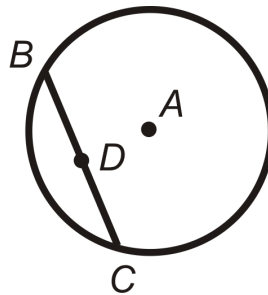

4. Connect A and D to form a diameter. How does \overline{AD} relate to the chord, \overline{BC} ?

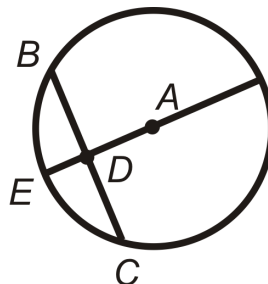

Chord Theorem #2: The perpendicular bisector of a chord is also a diameter.

In the picture to the left, $\overline{AD} \perp \overline{BC}$ and $\overline{BD} \cong \overline{DC}$. From this theorem, we also notice that \overline{AD} also bisects the corresponding arc at E , so $\widehat{BE} \cong \widehat{EC}$.

Chord Theorem #3: If a diameter is perpendicular to a chord, then the diameter bisects the chord and its corresponding arc.

Investigation: Properties of Congruent Chords

Tools Needed: pencil, paper, compass, ruler

1. Draw a circle with a radius of 2 inches and two chords that are both 3 inches. Label as in the picture to the right. *This diagram is drawn to scale.*

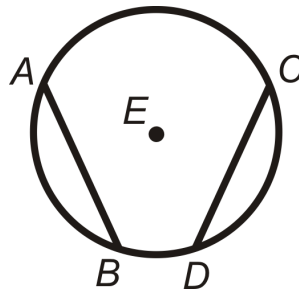

2. From the center, draw the perpendicular segment to \overline{AB} and \overline{CD} .

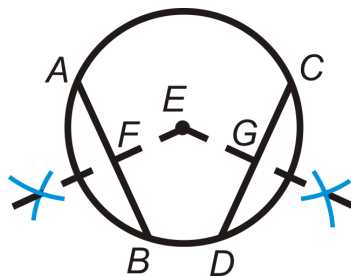

1. Erase the arc marks and lines beyond the points of intersection, leaving \overline{FE} and \overline{GE} . Find the measure of these segments. What do you notice?

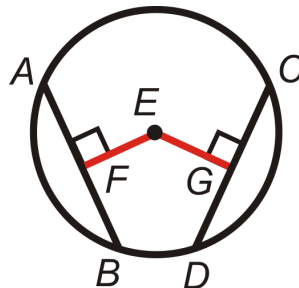

Chord Theorem #4: In the same circle or congruent circles, two chords are congruent if and only if they are equidistant from the center.

Recall that two lines are equidistant from the same point if and only if the shortest distance from the point to the line is congruent. The shortest distance from any point to a line is the perpendicular line between them. In this theorem, the fact that $FE = EG$ means that \overline{AB} and \overline{CD} are equidistant to the center and $\overline{AB} \cong \overline{CD}$.

Example A

Use $\odot A$ to answer the following.

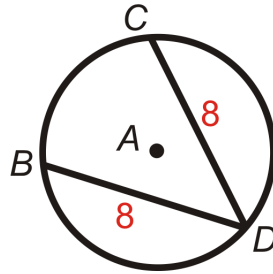

a) If $m\widehat{BD} = 125^\circ$, find $m\widehat{CD}$.

b) If $m\widehat{BC} = 80^\circ$, find $m\widehat{CD}$.

Solutions:

a) From the picture, we know $BD = CD$. Because the chords are equal, the arcs are too. $m\widehat{CD} = 125^\circ$.

b) To find $m\widehat{CD}$, subtract 80° from 360° and divide by 2. $m\widehat{CD} = \frac{360^\circ - 80^\circ}{2} = \frac{280^\circ}{2} = 140^\circ$

Example B

Find the value of x and y .

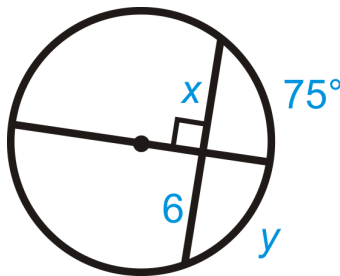

The diameter here is also perpendicular to the chord. From Chord Theorem #3, $x = 6$ and $y = 75^\circ$.

Example C

Find the value of x and y .

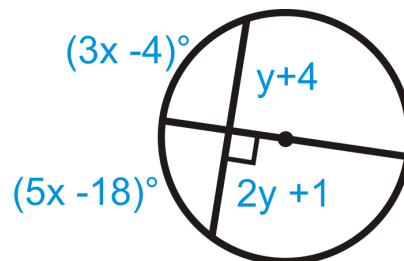

Because the diameter is perpendicular to the chord, it also bisects the chord and the arc. Set up an equation for x and y .

$$(3x - 4)^\circ = (5x - 18)^\circ$$

$$14^\circ = 2x$$

$$7^\circ = x$$

$$y + 4 = 2y + 1$$

$$3 = y$$

Watch this video for help with the Examples above.



MEDIA
Click image to the left for more content.

CK-12 Foundation: Chapter9ChordsinCirclesB

Concept Problem Revisited

In the picture, the chords from $\odot A$ and $\odot E$ are congruent and the chords from $\odot B, \odot C,$ and $\odot D$ are also congruent. We know this from Chord Theorem #1. All five chords are not congruent because all five circles are not congruent, even though the central angle for the circles is the same.

Vocabulary

A **circle** is the set of all points that are the same distance away from a specific point, called the **center**. A **radius** is the distance from the center to the outer rim of a circle. A **chord** is a line segment whose endpoints are on a circle. A **diameter** is a chord that passes through the center of the circle.

Guided Practice

1. Is the converse of Chord Theorem #2 true?
2. Find the value of x .

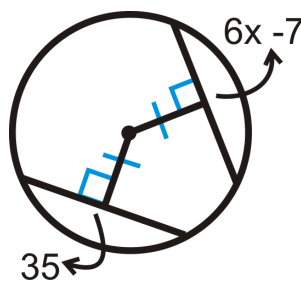

3. $BD = 12$ and $AC = 3$ in $\odot A$. Find the radius and $m\widehat{BD}$.

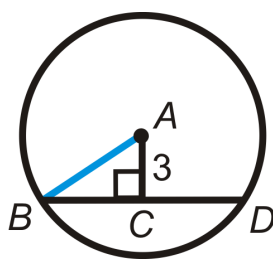

Answers:

1. The converse of Chord Theorem #2 would be: A diameter is also the perpendicular bisector of a chord. This is not a true statement, see the counterexample to the right.

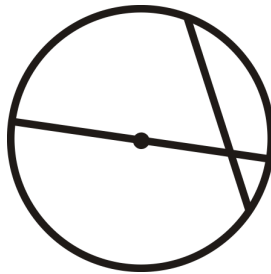

2. Because the distance from the center to the chords is congruent and perpendicular to the chords, then the chords are equal.

$$\begin{aligned}6x - 7 &= 35 \\6x &= 42 \\x &= 7\end{aligned}$$

3. First find the radius. In the picture, \overline{AB} is a radius, so we can use the right triangle $\triangle ABC$, such that \overline{AB} is the hypotenuse. From Chord Theorem #3, $BC = 6$.

$$\begin{aligned}3^2 + 6^2 &= AB^2 \\9 + 36 &= AB^2 \\AB &= \sqrt{45} = 3\sqrt{5}\end{aligned}$$

In order to find $m\widehat{BD}$, we need the corresponding central angle, $\angle BAD$. We can find half of $\angle BAD$ because it is an acute angle in $\triangle ABC$. Then, multiply the measure by 2 for $m\widehat{BD}$.

$$\begin{aligned}\tan^{-1}\left(\frac{6}{3}\right) &= m\angle BAC \\m\angle BAC &\approx 63.43^\circ\end{aligned}$$

This means that $m\angle BAD \approx 126.9^\circ$ and $m\widehat{BD} \approx 126.9^\circ$ as well.

Practice

Find the value of the indicated arc in $\odot A$.

1. $m\widehat{BC}$

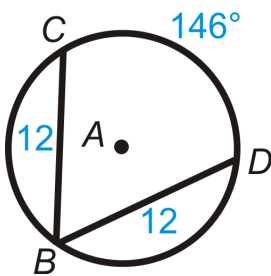

2. $m\widehat{BD}$

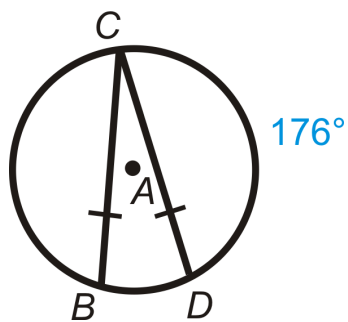

3. $m\widehat{BC}$

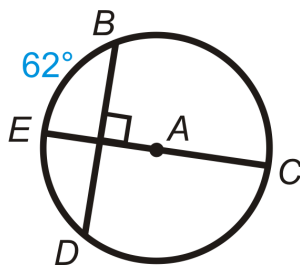

4. $m\widehat{BD}$

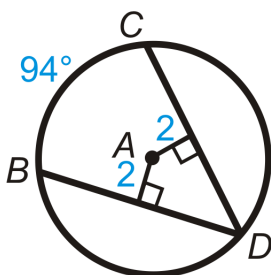

5. $m\widehat{BD}$

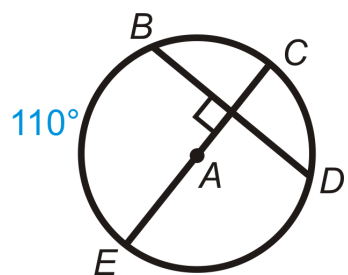

6. $m\widehat{BD}$

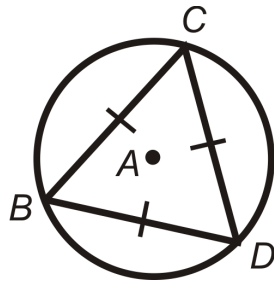

Algebra Connection Find the value of x and/or y .

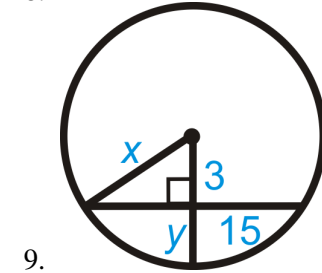
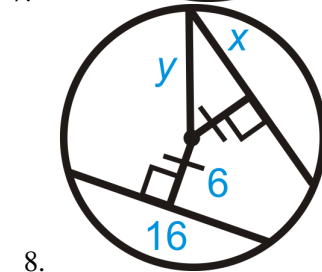
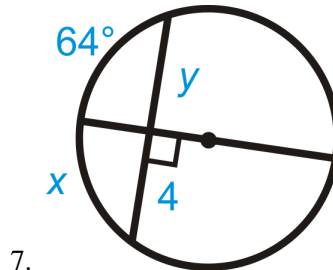

10. $AB = 32$

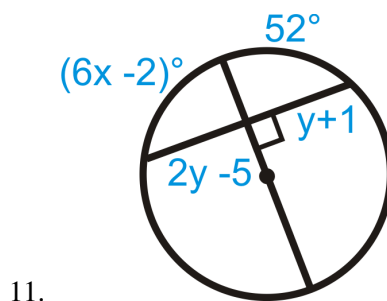
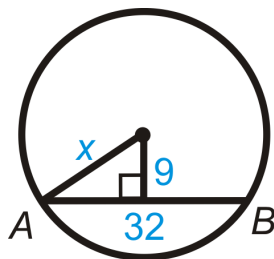

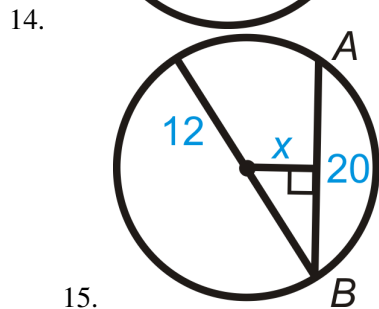
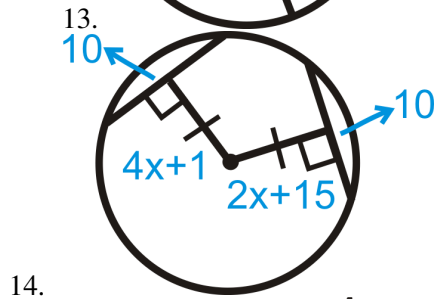
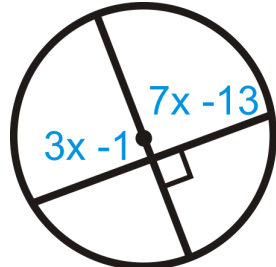
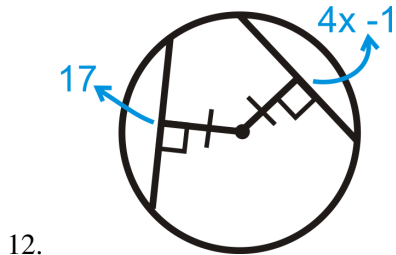

- 15.
16. Find $m\widehat{AB}$ in Question 10. Round your answer to the nearest tenth of a degree.
17. Find $m\widehat{AB}$ in Question 15. Round your answer to the nearest tenth of a degree.

In problems 18-20, what can you conclude about the picture? State a theorem that justifies your answer. You may assume that A is the center of the circle.

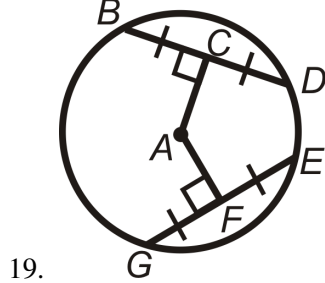
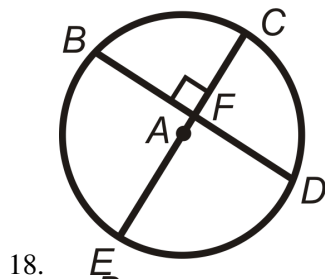

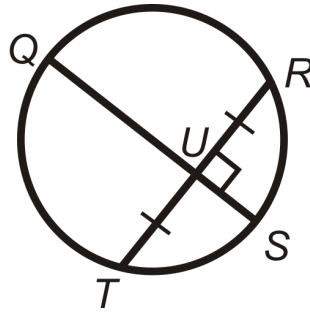

20.

21. Find the measure of \widehat{AB} in each diagram below.

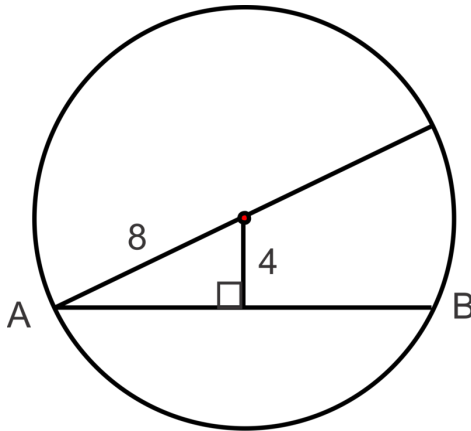

a.

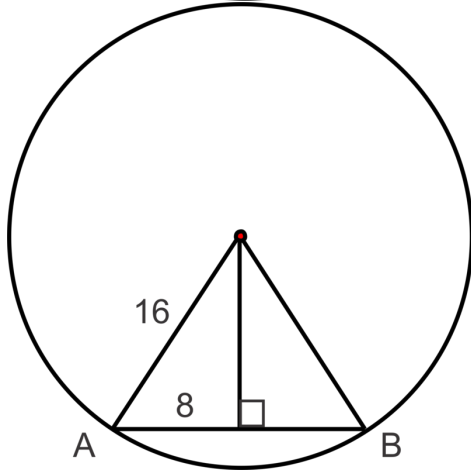

b.

9.5 Inscribed Angles in Circles

Here you'll learn the properties of inscribed angles and how to apply them.

What if your family went to Washington DC over the summer and saw the White House? The closest you can get to the White House are the walking trails on the far right. You got as close as you could (on the trail) to the fence to take a picture (you were not allowed to walk on the grass). Where else could you have taken your picture from to get the same frame of the White House? Where do you think the best place to stand would be? *Your line of sight in the camera is marked in the picture as the grey lines. The white dotted arcs do not actually exist, but were added to help with this problem.* After completing this Concept, you will be able to use inscribed angles to answer this question.

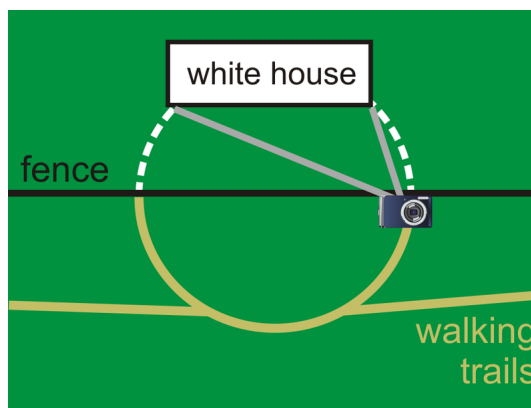

Watch This



MEDIA

Click image to the left for more content.

[CK-12 Foundation: Chapter9InscribedAnglesinCirclesA](#)

Learn more about inscribed angles by watching the video at this link.

Guidance

An **inscribed angle** is an angle with its vertex is the circle and its sides contain chords. The **intercepted arc** is the arc that is on the interior of the inscribed angle and whose endpoints are on the angle. The vertex of an inscribed angle can be anywhere on the circle as long as its sides intersect the circle to form an intercepted arc.

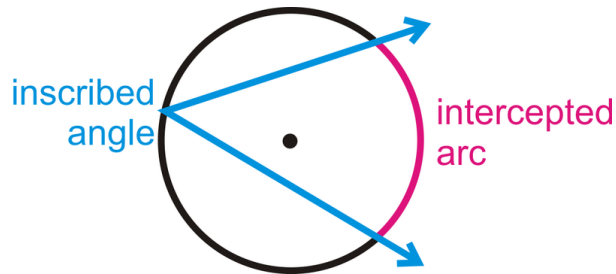

Let's investigate the relationship between the inscribed angle, the central angle and the arc they intercept.

Investigation: Measuring an Inscribed Angle

Tools Needed: pencil, paper, compass, ruler, protractor

1. Draw three circles with three different inscribed angles. For $\odot A$, make one side of the inscribed angle a diameter, for $\odot B$, make B inside the angle and for $\odot C$ make C outside the angle. Try to make all the angles different sizes.

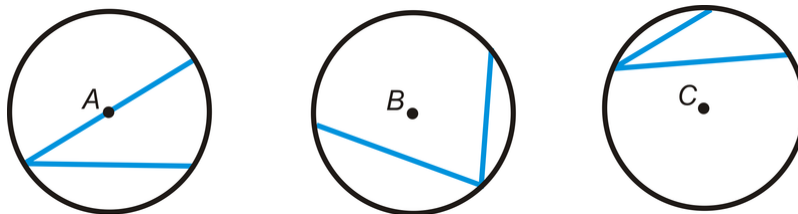

2. Using your ruler, draw in the corresponding central angle for each angle and label each set of endpoints.

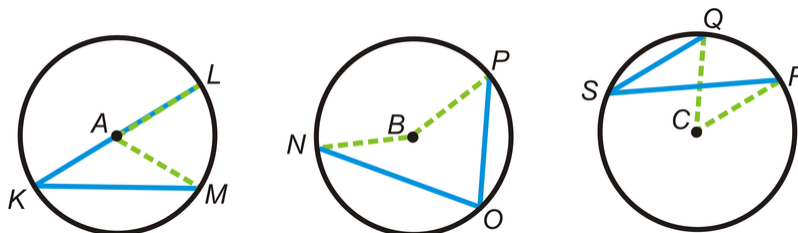

3. Using your protractor measure the six angles and determine if there is a relationship between the central angle, the inscribed angle, and the intercepted arc.

$$m\angle LAM = \underline{\hspace{2cm}}$$

$$m\angle NBP = \underline{\hspace{2cm}}$$

$$m\angle QCR = \underline{\hspace{2cm}}$$

$$m\widehat{LM} = \underline{\hspace{2cm}}$$

$$m\widehat{NP} = \underline{\hspace{2cm}}$$

$$m\widehat{QR} = \underline{\hspace{2cm}}$$

$$m\angle LKM = \underline{\hspace{2cm}}$$

$$m\angle NOP = \underline{\hspace{2cm}}$$

$$m\angle QSR = \underline{\hspace{2cm}}$$

Inscribed Angle Theorem: The measure of an inscribed angle is half the measure of its intercepted arc.

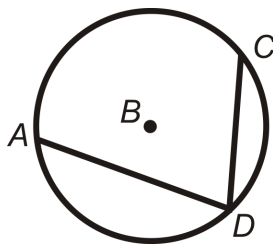

In the picture, $m\angle ADC = \frac{1}{2}m\widehat{AC}$. If we had drawn in the central angle $\angle ABC$, we could also say that $m\angle ADC = \frac{1}{2}m\angle ABC$ because the measure of the central angle is equal to the measure of the intercepted arc. To prove the Inscribed Angle Theorem, you would need to split it up into three cases, like the three different angles drawn from the Investigation.

Congruent Inscribed Angle Theorem: Inscribed angles that intercept the same arc are congruent.

Inscribed Angle Semicircle Theorem: An angle that intercepts a semicircle is a right angle.

In the Inscribed Angle Semicircle Theorem we could also say that the angle is inscribed in a semicircle. Anytime a right angle is inscribed in a circle, the endpoints of the angle are the endpoints of a diameter. Therefore, the converse of the Inscribed Angle Semicircle Theorem is also true.

Example A

Find $m\widehat{DC}$ and $m\angle ADB$.

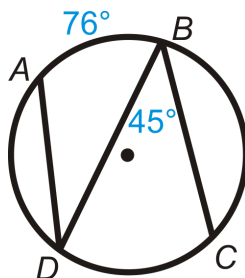

From the Inscribed Angle Theorem, $m\widehat{DC} = 2 \cdot 45^\circ = 90^\circ$. $m\angle ADB = \frac{1}{2} \cdot 76^\circ = 38^\circ$.

Example B

Find $m\angle ADB$ and $m\angle ACB$.

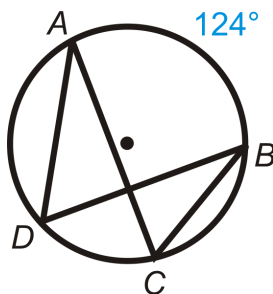

The intercepted arc for both angles is \widehat{AB} . Therefore, $m\angle ADB = m\angle ACB = \frac{1}{2} \cdot 124^\circ = 62^\circ$

Example C

Find $m\angle DAB$ in $\odot C$.

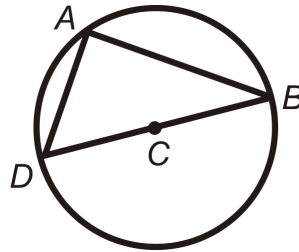

Because C is the center, \overline{DB} is a diameter. Therefore, $\angle DAB$ inscribes semicircle, or 180° . $m\angle DAB = \frac{1}{2} \cdot 180^\circ = 90^\circ$.

Watch this video for help with the Examples above.



MEDIA

Click image to the left for more content.

[CK-12 Foundation: Chapter9InscribedAnglesinCirclesB](#)

Concept Problem Revisited

You can take the picture from anywhere on the semicircular walking path. The best place to take the picture is subjective, but most would think the pale green frame, straight-on, would be the best view.

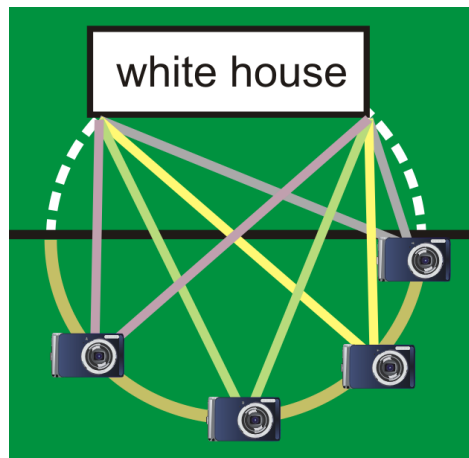
**Vocabulary**

A **circle** is the set of all points that are the same distance away from a specific point, called the **center**. A **radius** is the distance from the center to the circle. A **chord** is a line segment whose endpoints are on a circle. A **diameter** is a chord that passes through the center of the circle. The length of a diameter is two times the length of a radius. A **central angle** is an angle formed by two radii and whose vertex is at the center of the circle. An **inscribed angle** is an angle with its vertex on the circle and whose sides are chords. The **intercepted arc** is the arc that is inside the inscribed angle and whose endpoints are on the angle.

Guided Practice

Find $m\angle PMN$, $m\widehat{PN}$, $m\angle MNP$, $m\angle LNP$, and $m\widehat{LN}$.

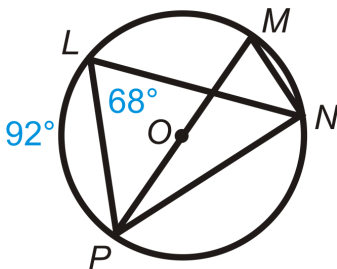

Answers:

$m\angle PMN = m\angle PLN = 68^\circ$ by the Congruent Inscribed Angle Theorem.

$m\widehat{PN} = 2 \cdot 68^\circ = 136^\circ$ from the Inscribed Angle Theorem.

$m\angle MNP = 90^\circ$ by the Inscribed Angle Semicircle Theorem.

$m\angle LNP = \frac{1}{2} \cdot 92^\circ = 46^\circ$ from the Inscribed Angle Theorem.

To find $m\widehat{LN}$, we need to find $m\angle LPN$. $\angle LPN$ is the third angle in $\triangle LPN$, so $68^\circ + 46^\circ + m\angle LPN = 180^\circ$. $m\angle LPN = 66^\circ$, which means that $m\widehat{LN} = 2 \cdot 66^\circ = 132^\circ$.

Practice

Fill in the blanks.

1. An angle inscribed in a _____ is 90° .
2. Two inscribed angles that intercept the same arc are _____.
3. The sides of an inscribed angle are _____.
4. Draw inscribed angle $\angle JKL$ in $\odot M$. Then draw central angle $\angle JML$. How do the two angles relate?

Find the value of x and/or y in $\odot A$.

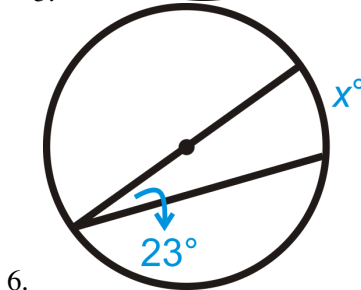
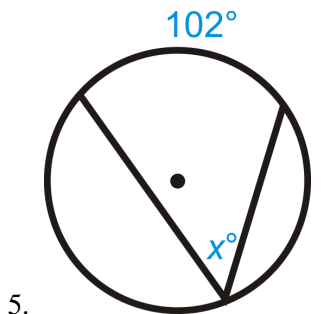

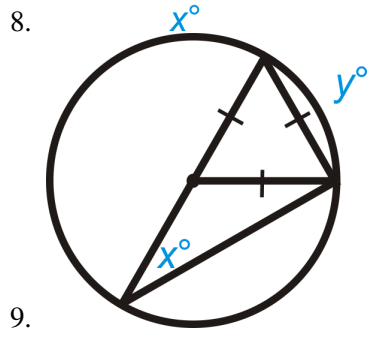
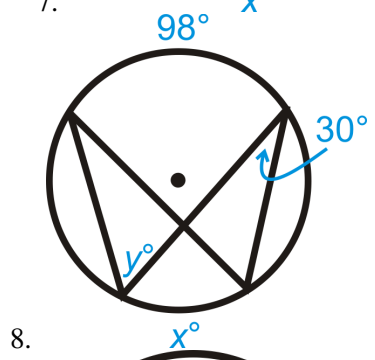
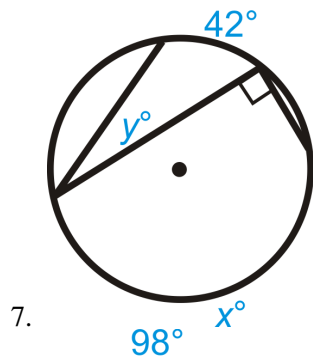

Solve for x .

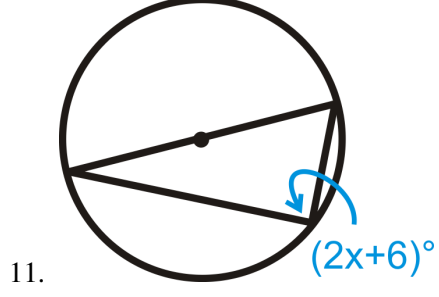
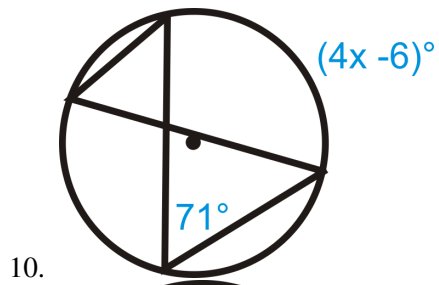

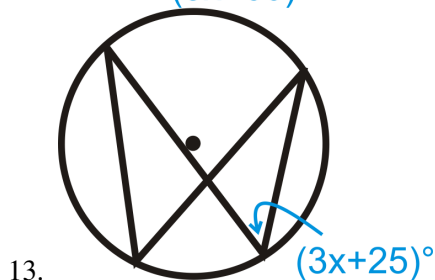
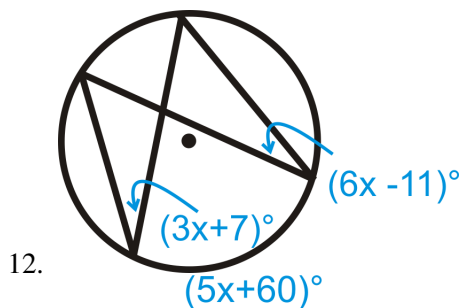

14. Suppose that \overline{AB} is a diameter of a circle centered at O , and C is any other point on the circle. Draw the line through O that is parallel to \overline{AC} , and let D be the point where it meets \widehat{BC} . Explain why D is the midpoint of \widehat{BC} .
15. Fill in the blanks of the Inscribed Angle Theorem proof.

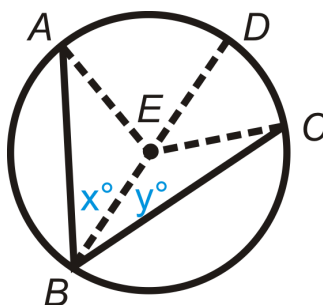

Given: Inscribed $\angle ABC$ and diameter \overline{BD}

Prove: $m\angle ABC = \frac{1}{2}m\widehat{AC}$

TABLE 9.2:

Statement

1. Inscribed $\angle ABC$ and diameter \overline{BD}

$m\angle ABE = x^\circ$ and $m\angle CBE = y^\circ$

2. $x^\circ + y^\circ = m\angle ABC$

3.

4.

5. $m\angle EAB = x^\circ$ and $m\angle ECB = y^\circ$

6. $m\angle AED = 2x^\circ$ and $m\angle CED = 2y^\circ$

7. $m\widehat{AD} = 2x^\circ$ and $m\widehat{DC} = 2y^\circ$

8.

9. $m\widehat{AC} = 2x^\circ + 2y^\circ$

10.

11. $m\widehat{AC} = 2m\angle ABC$

12. $m\angle ABC = \frac{1}{2}m\widehat{AC}$

Reason

All radii are congruent

Definition of an isosceles triangle

Arc Addition Postulate

Distributive PoE

9.6 Inscribed Quadrilaterals in Circles

Here you'll learn properties of inscribed quadrilaterals in circles and how to apply them.

What if you were given a circle with a quadrilateral inscribed in it? How could you use information about the arcs formed by the quadrilateral and/or the quadrilateral's angle measures to find the measure of the unknown quadrilateral angles? After completing this Concept, you'll be able to apply the Inscribed Quadrilateral Theorem to solve problems like this one.

Watch This



MEDIA

Click image to the left for more content.

[CK-12 Foundation: Chapter9InscribedQuadrilateralsinCirclesA](#)

Learn more about cyclic quadrilaterals and parallel lines in circles by watching the video at this link.

Guidance

An **inscribed polygon** is a polygon where every vertex is on a circle. Note, that not every quadrilateral or polygon can be inscribed in a circle. Inscribed quadrilaterals are also called *cyclic quadrilaterals*. For these types of quadrilaterals, they must have one special property. We will investigate it here.

Investigation: Inscribing Quadrilaterals

Tools Needed: pencil, paper, compass, ruler, colored pencils, scissors

1. Draw a circle. Mark the center point A .

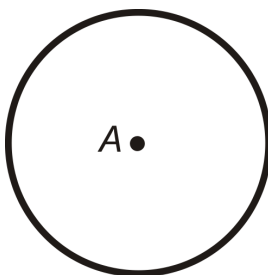

2. Place four points on the circle. Connect them to form a quadrilateral. Color the 4 angles of the quadrilateral 4 different colors.

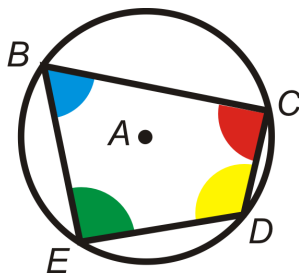

3. Cut out the quadrilateral. Then cut the quadrilateral into two triangles, by cutting on a diagonal.

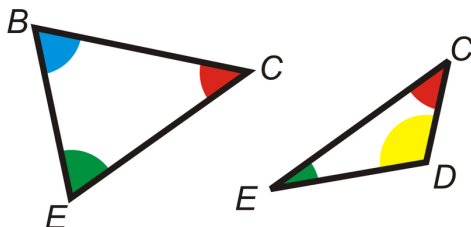

4. Line up $\angle B$ and $\angle D$ so that they are adjacent angles. What do you notice? What does this show?

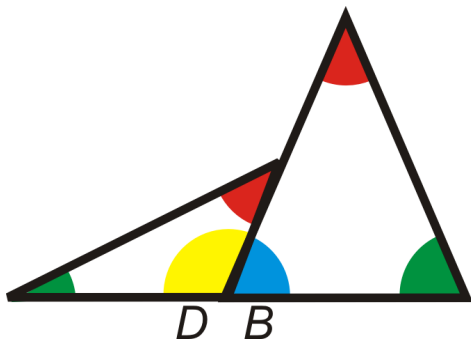

This investigation shows that the opposite angles in an inscribed quadrilateral are supplementary. By cutting the quadrilateral in half, through the diagonal, we were able to show that the other two angles (that we did not cut through) formed a linear pair when matched up.

Inscribed Quadrilateral Theorem: A quadrilateral is inscribed in a circle if and only if the opposite angles are supplementary.

Example A

Find the value of the missing variable.

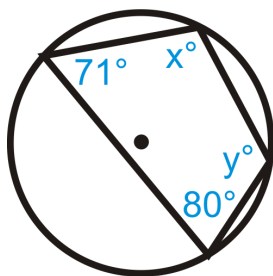

$x + 80^\circ = 180^\circ$ by the Inscribed Quadrilateral Theorem. $x = 100^\circ$.

$y + 71^\circ = 180^\circ$ by the Inscribed Quadrilateral Theorem. $y = 109^\circ$.

Example B

Find the value of the missing variable.

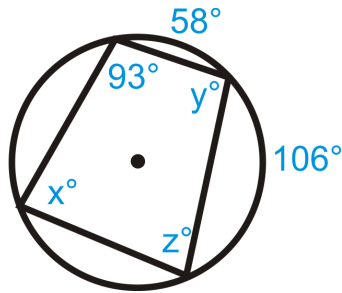

It is easiest to figure out z first. It is supplementary with 93° , so $z = 87^\circ$. Second, we can find x . x is an inscribed angle that intercepts the arc $58^\circ + 106^\circ = 164^\circ$. Therefore, by the Inscribed Angle Theorem, $x = 82^\circ$. y is supplementary with x , so $y = 98^\circ$. Find the value of the missing variables.

Example C

Find x and y in the picture below.

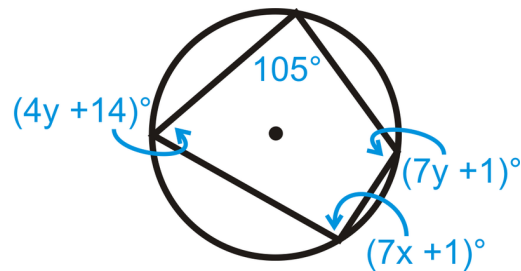

The opposite angles are supplementary. Set up an equation for x and y .

$$(7x + 1)^\circ + 105^\circ = 180^\circ$$

$$7x + 106^\circ = 180^\circ$$

$$7x = 84^\circ$$

$$x = 12^\circ$$

$$(4y + 14)^\circ + (7y + 1)^\circ = 180^\circ$$

$$11y + 15^\circ = 180^\circ$$

$$11y = 165^\circ$$

$$y = 15^\circ$$

Watch this video for help with the Examples above.



MEDIA

Click image to the left for more content.

Vocabulary

A **circle** is the set of all points that are the same distance away from a specific point, called the **center**. A **radius** is the distance from the center to the circle. A **chord** is a line segment whose endpoints are on a circle. A **diameter** is a chord that passes through the center of the circle. The length of a diameter is two times the length of a radius. A **central angle** is an angle formed by two radii and whose vertex is at the center of the circle. An **inscribed angle** is an angle with its vertex on the circle and whose sides are chords. The **intercepted arc** is the arc that is inside the inscribed angle and whose endpoints are on the angle. An **inscribed polygon** is a polygon where every vertex is on the circle.

Guided Practice

Quadrilateral $ABCD$ is inscribed in $\odot E$. Find:

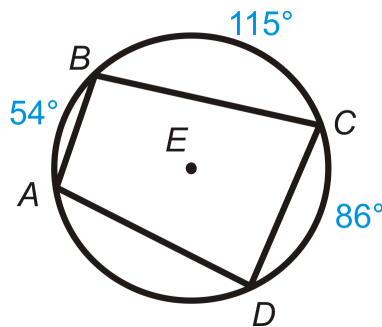

1. $m\angle A$
2. $m\angle B$
3. $m\angle C$
4. $m\angle D$

Answers:

First, note that $m\widehat{AD} = 105^\circ$ because the complete circle must add up to 360° .

1. $m\angle A = \frac{1}{2}m\widehat{BD} = \frac{1}{2}(115 + 86) = 100.5^\circ$
2. $m\angle B = \frac{1}{2}m\widehat{AC} = \frac{1}{2}(86 + 105) = 95.5^\circ$
3. $m\angle C = 180^\circ - m\angle A = 180^\circ - 100.5^\circ = 79.5^\circ$
4. $m\angle D = 180^\circ - m\angle B = 180^\circ - 95.5^\circ = 84.5^\circ$

Practice

Fill in the blanks.

1. A(n) _____ polygon has all its vertices on a circle.
2. The _____ angles of an inscribed quadrilateral are _____.

Quadrilateral $ABCD$ is inscribed in $\odot E$. Find:

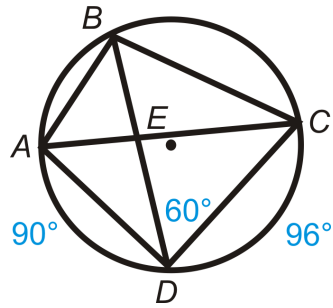

3. $m\angle DBC$
4. $m\widehat{BC}$
5. $m\widehat{AB}$
6. $m\angle ACD$
7. $m\angle ADC$
8. $m\angle ACB$

Find the value of x and/or y in $\odot A$.

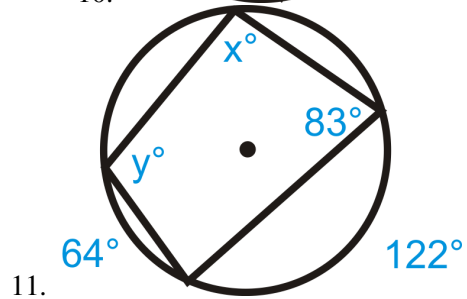
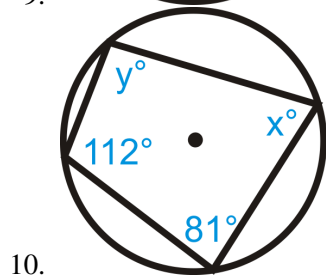
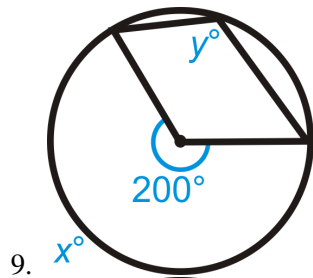

Solve for x .

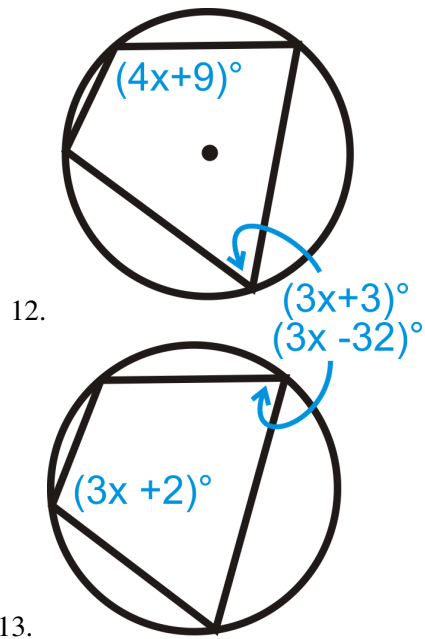

Use the diagram below to find the measures of the indicated angles and arcs in problems 14-19.

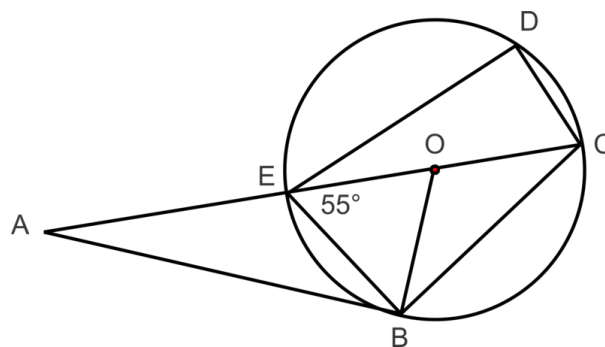

14. $m\angle EBO$
15. $m\angle EOB$
16. $m\widehat{BC}$
17. $m\angle ABO$
18. $m\angle A$
19. $m\angle EDC$

9.7 Angles On and Inside a Circle

Here you'll learn how to solve problems containing angles that are on or inside a circle.

What if you were given a circle with either a chord and a tangent or two chords that meet at a common point? How could you use the measure of the arc(s) formed by those circle parts to find the measure of the angles they make on or inside the circle? After completing this Concept, you'll be able to apply the Chord/Tangent Angle Theorem and the Intersecting Chords Angle Theorem to solve problems like this one.

Watch This



MEDIA

Click image to the left for more content.

[CK-12 Foundation: Chapter9AnglesOnandInsideaCircleA](#)

Learn more about chords and tangents by watching the second part of the video at this link.

Follow this link to watch a video about secants.

Guidance

When an angle is on a circle, the vertex is on the circumference of the circle. One type of angle *on* a circle is one formed by a tangent and a chord.

Investigation: The Measure of an Angle formed by a Tangent and a Chord

Tools Needed: pencil, paper, ruler, compass, protractor

1. Draw $\odot A$ with chord \overline{BC} and tangent line \overleftrightarrow{ED} with point of tangency C .

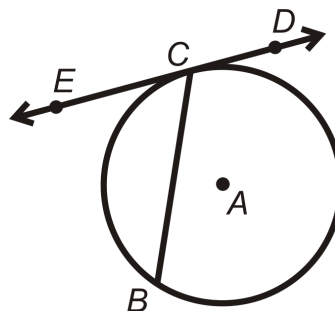

2. Draw in central angle $\angle CAB$. Then, using your protractor, find $m\angle CAB$ and $m\angle BCE$.

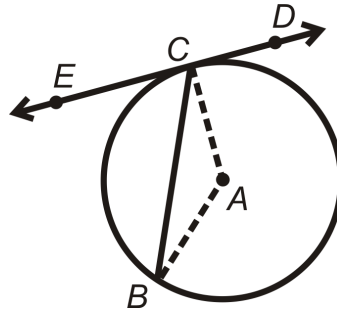

- Find $m\widehat{BC}$ (the minor arc). How does the measure of this arc relate to $m\angle BCE$?

This investigation proves the Chord/Tangent Angle Theorem.

Chord/Tangent Angle Theorem: The measure of an angle formed by a chord and a tangent that intersect on the circle is half the measure of the intercepted arc.

From the Chord/Tangent Angle Theorem, we now know that there are two types of angles that are half the measure of the intercepted arc; an inscribed angle and an angle formed by a chord and a tangent. Therefore, **any angle with its vertex on a circle will be half the measure of the intercepted arc.**

An angle is considered *inside* a circle when the vertex is somewhere inside the circle, but not on the center. All angles inside a circle are formed by two intersecting chords.

Investigation: Find the Measure of an Angle *inside* a Circle

Tools Needed: pencil, paper, compass, ruler, protractor, colored pencils (optional)

- Draw $\odot A$ with chord \overline{BC} and \overline{DE} . Label the point of intersection P .

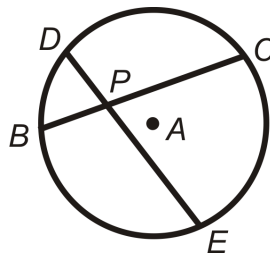

- Draw central angles $\angle DAB$ and $\angle CAE$. Use colored pencils, if desired.

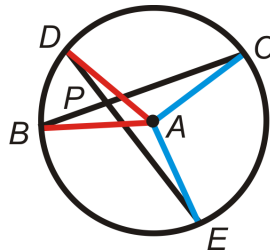

- Using your protractor, find $m\angle DPB$, $m\angle DAB$, and $m\angle CAE$. What is $m\widehat{DB}$ and $m\widehat{CE}$?
- Find $\frac{m\widehat{DB} + m\widehat{CE}}{2}$.
- What do you notice?

Intersecting Chords Angle Theorem: The measure of the angle formed by two chords that intersect *inside* a circle is the average of the measure of the intercepted arcs.

In the picture below:

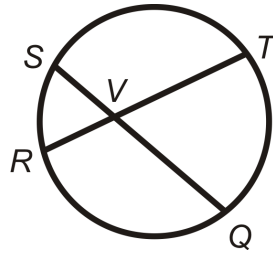

$$m\angle SVR = \frac{1}{2} (m\widehat{SR} + m\widehat{TQ}) = \frac{m\widehat{SR} + m\widehat{TQ}}{2} = m\angle TVQ$$

$$m\angle SVT = \frac{1}{2} (m\widehat{ST} + m\widehat{RQ}) = \frac{m\widehat{ST} + m\widehat{RQ}}{2} = m\angle RVQ$$

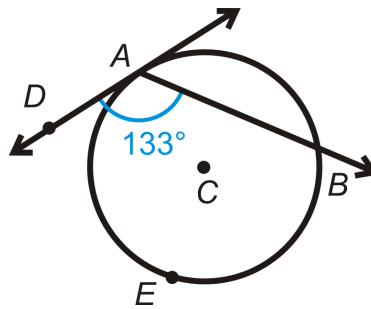
Example AFind $m\widehat{AEB}$ 

Use the Chord/Tangent Angle Theorem.

$$m\widehat{AEB} = 2 \cdot m\angle DAB = 2 \cdot 133^\circ = 266^\circ$$

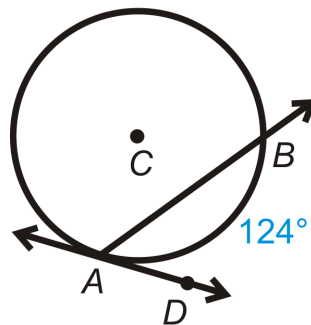
Example BFind $m\angle BAD$.

Use the Chord/Tangent Angle Theorem.

$$m\angle BAD = \frac{1}{2} m\widehat{AB} = \frac{1}{2} \cdot 124^\circ = 62^\circ$$

Example C

Find a , b , and c .

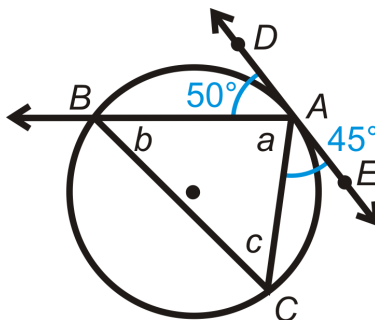

To find a , it is in line with 50° and 45° . The three angles add up to 180° . $50^\circ + 45^\circ + m\angle a = 180^\circ, m\angle a = 85^\circ$.

b is an inscribed angle, so its measure is half of $m\widehat{AC}$. From the Chord/Tangent Angle Theorem, $m\widehat{AC} = 2 \cdot m\angle EAC = 2 \cdot 45^\circ = 90^\circ$.

$$m\angle b = \frac{1}{2} \cdot m\widehat{AC} = \frac{1}{2} \cdot 90^\circ = 45^\circ.$$

To find c , you can either use the Triangle Sum Theorem or the Chord/Tangent Angle Theorem. We will use the Triangle Sum Theorem. $85^\circ + 45^\circ + m\angle c = 180^\circ, m\angle c = 50^\circ$.

Watch this video for help with the Examples above.

**MEDIA**

Click image to the left for more content.

[CK-12 Foundation: Chapter9AnglesOnandInsideaCircleB](#)

Vocabulary

A **circle** is the set of all points that are the same distance away from a specific point, called the **center**. A **radius** is the distance from the center to the circle. A **chord** is a line segment whose endpoints are on a circle. A **diameter** is a chord that passes through the center of the circle. The length of a diameter is two times the length of a radius. A **central angle** is the angle formed by two radii and whose vertex is at the center of the circle. An **inscribed angle** is an angle with its vertex on the circle and whose sides are chords. The **intercepted arc** is the arc that is inside the inscribed angle and whose endpoints are on the angle. A **tangent** is a line that intersects a circle in exactly one point. The **point of tangency** is the point where the tangent line touches the circle.

Guided Practice

Find x .

1.

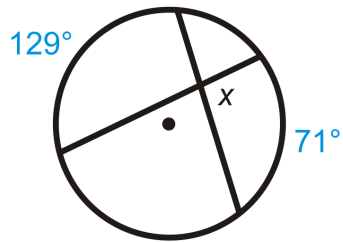

2.

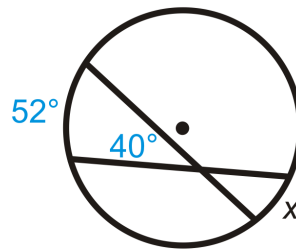

3.

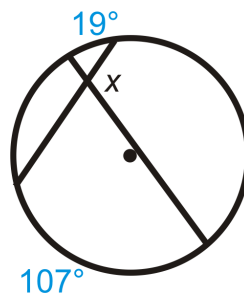
**Answers:**

Use the Intersecting Chords Angle Theorem and write an equation.

1. The intercepted arcs for x are 129° and 71° .

$$x = \frac{129^\circ + 71^\circ}{2} = \frac{200^\circ}{2} = 100^\circ$$

2. Here, x is one of the intercepted arcs for 40° .

$$40^\circ = \frac{52^\circ + x}{2}$$

$$80^\circ = 52^\circ + x$$

$$38^\circ = x$$

3. x is supplementary to the angle that the average of the given intercepted arcs. We will call this supplementary angle y .

$$y = \frac{19^\circ + 107^\circ}{2} = \frac{126^\circ}{2} = 63^\circ \text{ This means that } x = 117^\circ; 180^\circ - 63^\circ$$

Practice

Find the value of the missing variable(s).

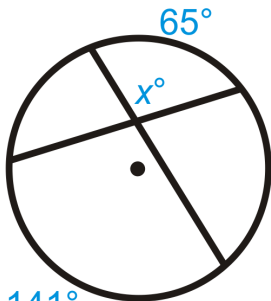

1. 141°
 200°

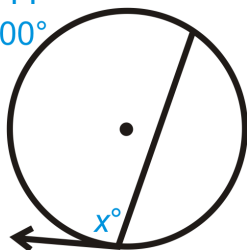

- 2.

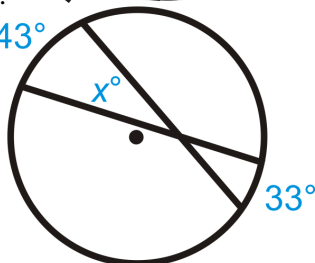

- 3.

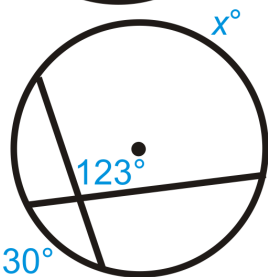

4. 30°

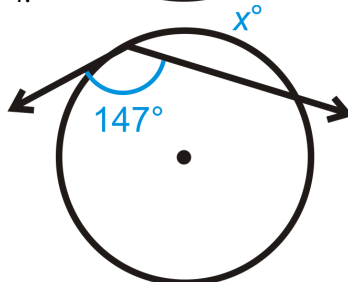

- 5.

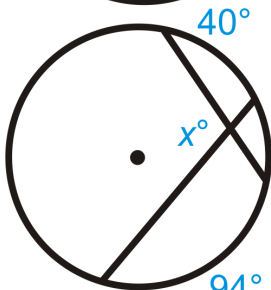

- 6.

7. $y \neq 60^\circ$

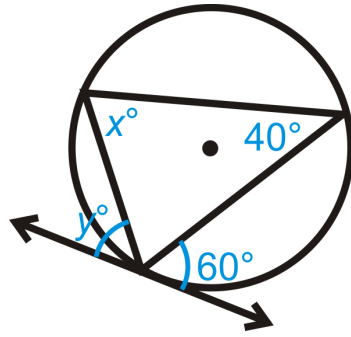

Solve for x .

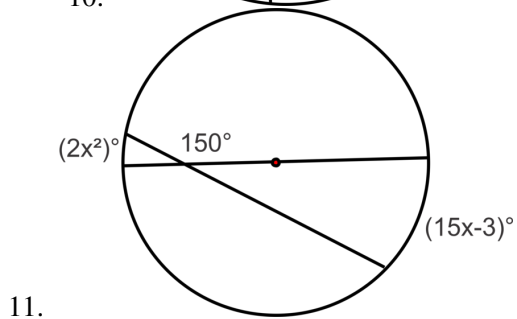
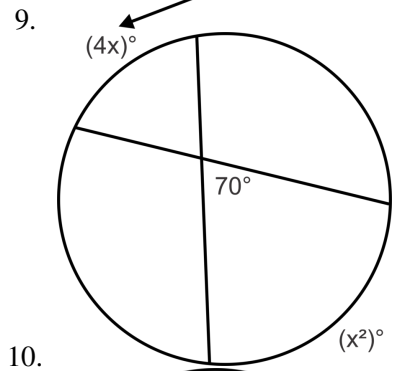
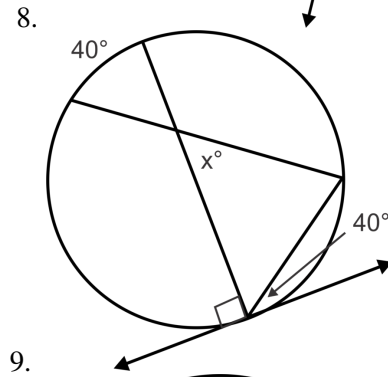
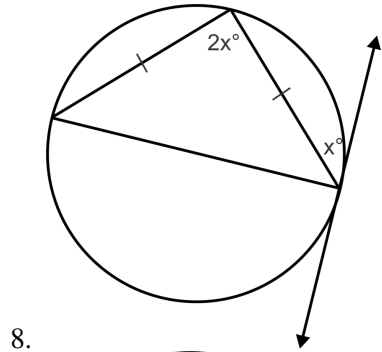

12. Prove the Intersecting Chords Angle Theorem.

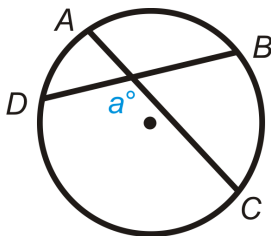

Given: Intersecting chords \overline{AC} and \overline{BD} .

Prove: $m\angle a = \frac{1}{2} (m\widehat{DC} + m\widehat{AB})$

Fill in the blanks.

13. If the vertex of an angle is _____ a circle, then its measure is the average of the _____ - _____ arcs.
14. If the vertex of an angle is _____ a circle, then its measure is _____ the intercepted arc.
15. Can two tangent lines intersect inside a circle? Why or why not?

9.8 Angles Outside a Circle

Here you'll learn how to calculate angles formed outside a circle by tangent and secant lines.

What if you wanted to figure out the angle at which the sun's rays hit the earth? The sun's rays hit the earth such that the tangent rays determine when daytime and night time are. The time and Earth's rotation determine when certain locations have sun. If the arc that is exposed to sunlight is 178° , what is the angle at which the sun's rays hit the earth (x°)? After completing this Concept, you'll be able to use properties of angles created by tangent lines to answer this question.



Watch This



MEDIA

Click image to the left for more content.

CK-12 Foundation: [Chapter9AnglesOutsideaCircleA](#)

Learn more aboutsecantsby watchingthesecond halfof thisvideo.

Guidance

An angle is considered to be outside a circle if the vertex of the angle is outside the circle and the sides are tangents or secants. There are three types of angles that are outside a circle: an angle formed by two tangents, an angle formed by a tangent and a secant, and an angle formed by two secants. Just like an angle inside or on a circle, an angle outside a circle has a specific formula, involving the intercepted arcs.

Investigation: Find the Measure of an Angle outside a Circle

Tools Needed: pencil, paper, ruler, compass, protractor, colored pencils (optional)

1. Draw three circles and label the centers $A, B,$ and C . In $\odot A$ draw two secant rays with the same endpoint, \overrightarrow{DE} and \overrightarrow{DF} . In $\odot B$, draw two tangent rays with the same endpoint, \overrightarrow{LM} and \overrightarrow{LN} . In $\odot C$, draw a tangent ray and a secant ray with the same endpoint, \overrightarrow{QR} and \overrightarrow{QS} . Label the points of intersection with the circles like they are in the pictures below.

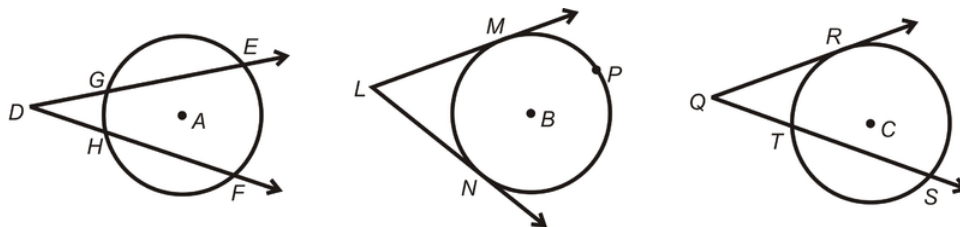

2. Draw in all the central angles: $\angle GAH, \angle EAF, \angle MBN, \angle RCT, \angle RCS$. Then, find the measures of each of these angles using your protractor. Use color to differentiate.

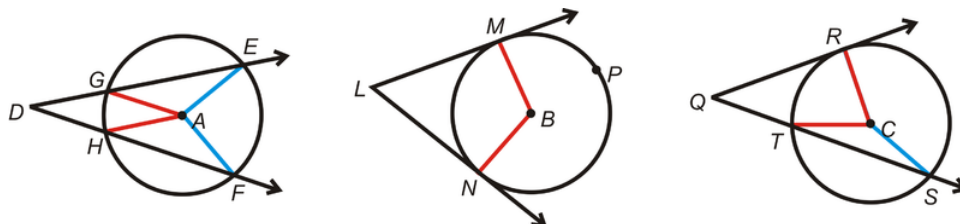

- Find $m\angle EDF, m\angle MLN$, and $m\angle RQS$.
- Find $\frac{m\widehat{EF} - m\widehat{GH}}{2}, \frac{m\widehat{MPN} - m\widehat{MN}}{2}$, and $\frac{m\widehat{RS} - m\widehat{RT}}{2}$. What do you notice?

Outside Angle Theorem: The measure of an angle formed by two secants, two tangents, or a secant and a tangent drawn from a point outside the circle is equal to half the difference of the measures of the intercepted arcs.

Example A

Find the value of x . You may assume lines that look tangent, are.

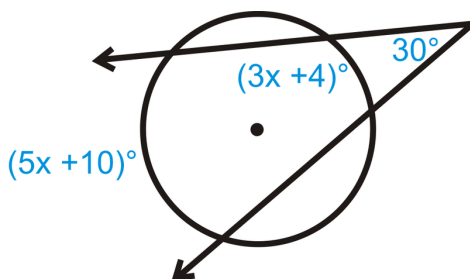

Set up an equation using the Outside Angle Theorem.

$$\begin{aligned} \frac{(5x + 10)^\circ - (3x + 4)^\circ}{2} &= 30^\circ \\ (5x + 10)^\circ - (3x + 4)^\circ &= 60^\circ \\ 5x + 10^\circ - 3x - 4^\circ &= 60^\circ \\ 2x + 6^\circ &= 60^\circ \\ 2x &= 54^\circ \\ x &= 27^\circ \end{aligned}$$

Example B

Find the value of x .

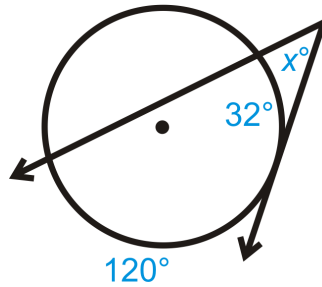

$$x = \frac{120^\circ - 32^\circ}{2} = \frac{88^\circ}{2} = 44^\circ.$$

Example C

Find the value of x .

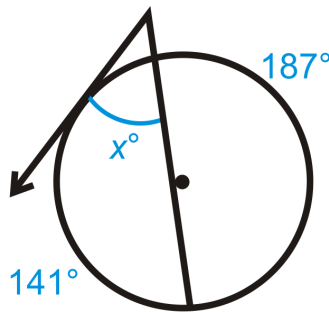

First note that the missing arc by angle x measures 32° because the complete circle must make 360° . Then, $x = \frac{141^\circ - 32^\circ}{2} = \frac{109^\circ}{2} = 54.5^\circ$.

Watch this video for help with the Examples above.



MEDIA

Click image to the left for more content.

[CK-12 Foundation: Chapter9AnglesOutsideaCircleB](#)

Concept Problem Revisited

If 178° of the Earth is exposed to the sun, then the angle at which the sun's rays hit the Earth is 2° . From the Outside Angle Theorem, these two angles are supplementary. From this, we also know that the other 182° of the Earth is not exposed to sunlight and it is probably night time.

Vocabulary

A **circle** is the set of all points that are the same distance away from a specific point, called the **center**. A **radius** is the distance from the center to the circle. A **chord** is a line segment whose endpoints are on a circle. A **diameter** is a chord that passes through the center of the circle. The length of a diameter is two times the length of a radius. A **central angle** is the angle formed by two radii and whose vertex is at the center of the circle. An **inscribed angle**

is an angle with its vertex on the circle and whose sides are chords. The *intercepted arc* is the arc that is inside the inscribed angle and whose endpoints are on the angle. A *tangent* is a line that intersects a circle in exactly one point. The *point of tangency* is the point where the tangent line touches the circle. A *secant* is a line that intersects a circle in two points.

Guided Practice

Find the measure of x .

1.

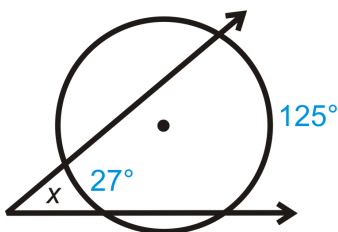

2.

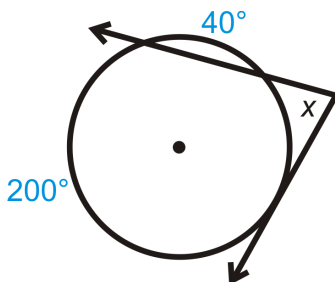

3.

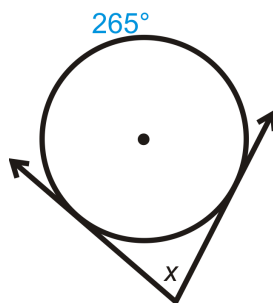

Answers:

For all of the above problems we can use the Outside Angle Theorem.

$$1. x = \frac{125^\circ - 27^\circ}{2} = \frac{98^\circ}{2} = 49^\circ$$

$$2. 40^\circ \text{ is not the intercepted arc. Be careful! The intercepted arc is } 120^\circ, (360^\circ - 200^\circ - 40^\circ). \text{ Therefore, } x = \frac{200^\circ - 120^\circ}{2} = \frac{80^\circ}{2} = 40^\circ.$$

$$3. \text{ First, we need to find the other intercepted arc, } 360^\circ - 265^\circ = 95^\circ. x = \frac{265^\circ - 95^\circ}{2} = \frac{170^\circ}{2} = 85^\circ$$

Practice

Find the value of the missing variable(s).

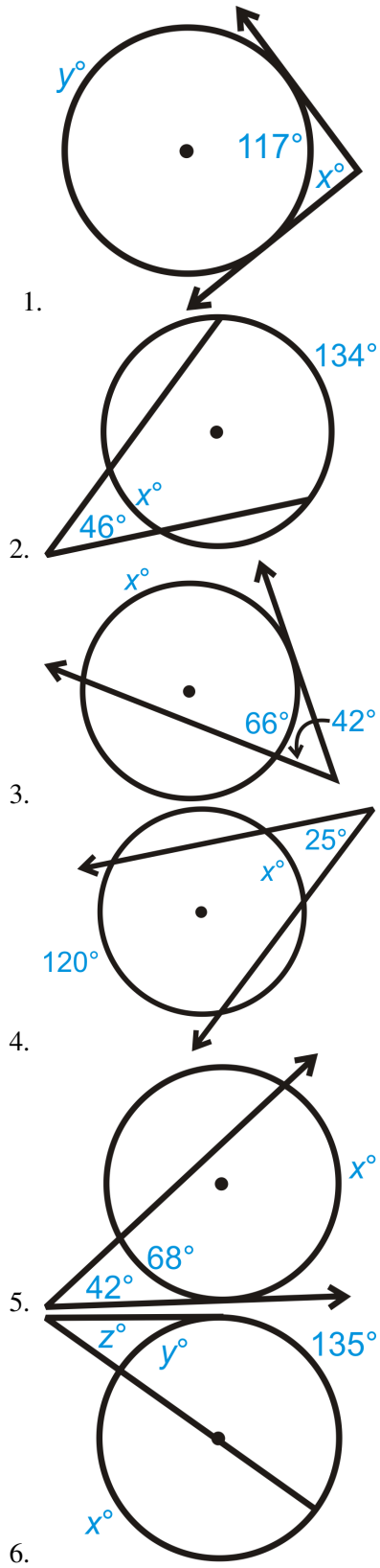

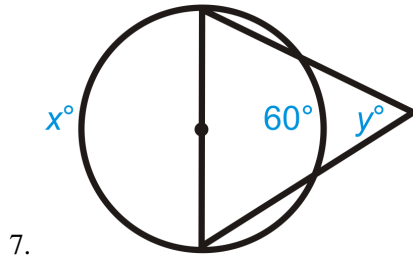

Solve for x .

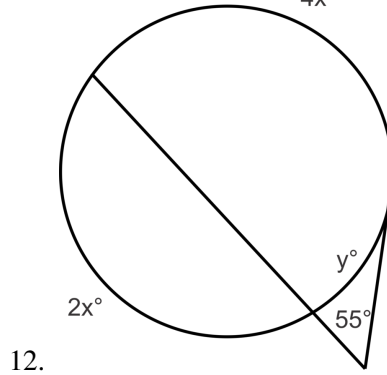
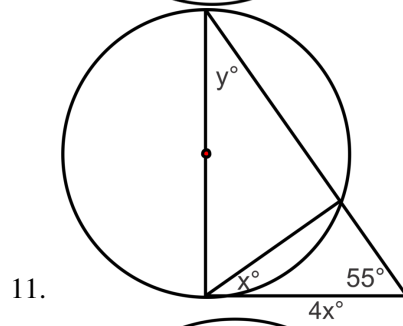
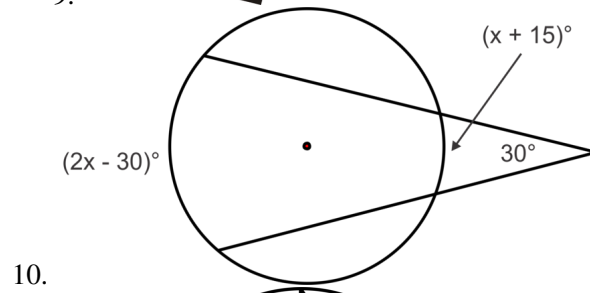
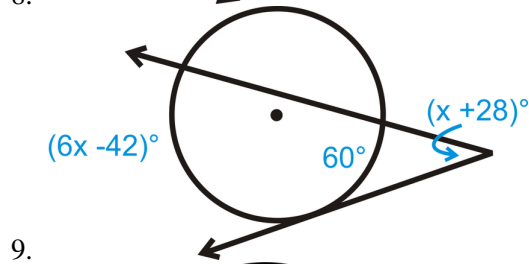
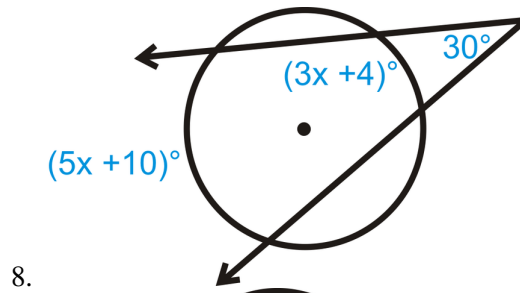

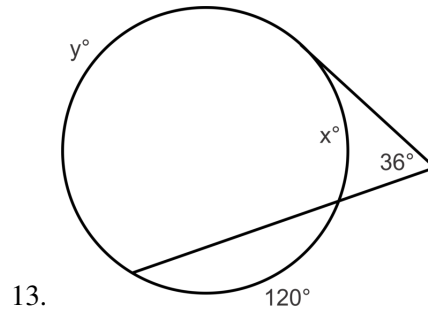

14. Prove the Outside Angle Theorem

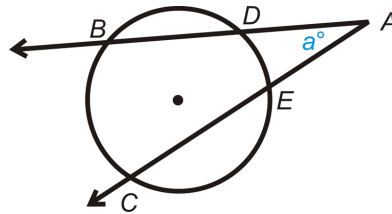

Given: Secant rays \overrightarrow{AB} and \overrightarrow{AC}

Prove: $m\angle a = \frac{1}{2} (m\widehat{BC} - m\widehat{DE})$

15. Draw two secants that intersect:

- inside a circle.
- on a circle.
- outside a circle.

9.9 Segments from Chords

Here you'll learn how to solve for missing segments from chords in circles.

What if Ishmael wanted to know the diameter of a CD from his car? He found a broken piece of one in his car and took some measurements. He places a ruler across two points on the rim, and the length of the chord is 9.5 cm. The distance from the midpoint of this chord to the nearest point on the rim is 1.75 cm. Find the diameter of the CD. After completing this Concept, you'll be able to use your knowledge of chords to solve this problem.

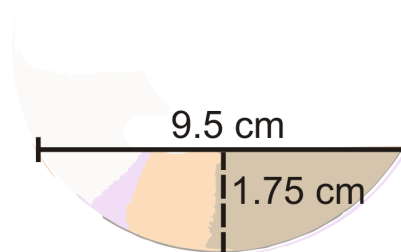

Watch This



MEDIA

Click image to the left for more content.

[CK-12 Foundation: Chapter9SegmentsfromChordsA](#)

[Learn more aboutsecantsby watchingthevideo at this link.](#)

Guidance

When two chords intersect inside a circle, the two triangles they create are similar, making the sides of each triangle in proportion with each other. If we remove \overline{AD} and \overline{BC} the ratios between \overline{AE} , \overline{EC} , \overline{DE} , and \overline{EB} will still be the same.

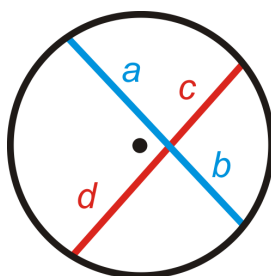

Intersecting Chords Theorem: If two chords intersect inside a circle so that one is divided into segments of length a and b and the other into segments of length c and d then $ab = cd$. In other words, the product of the segments of one chord is equal to the product of segments of the second chord.

Example A

Find x in the diagram below.

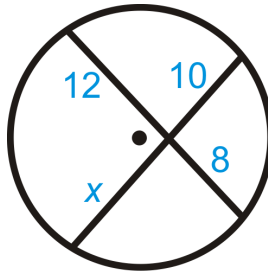

Use the ratio from the Intersecting Chords Theorem. The product of the segments of one chord is equal to the product of the segments of the other.

$$\begin{aligned} 12 \cdot 8 &= 10 \cdot x \\ 96 &= 10x \\ 9.6 &= x \end{aligned}$$

Example B

Find x in the diagram below.

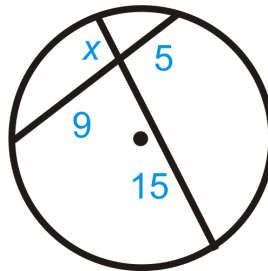

Use the ratio from the Intersecting Chords Theorem. The product of the segments of one chord is equal to the product of the segments of the other.

$$\begin{aligned} x \cdot 15 &= 5 \cdot 9 \\ 15x &= 45 \\ x &= 3 \end{aligned}$$

Example C

Solve for x .

a)

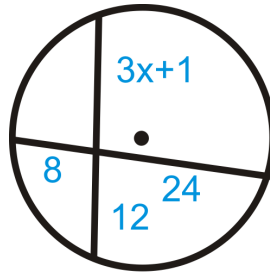

b)

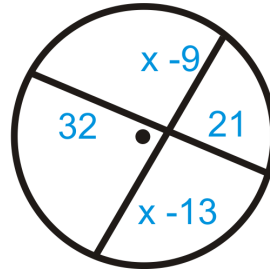

Again, we can use the Intersecting Chords Theorem. Set up an equation and solve for x .

a)

$$\begin{aligned} 8 \cdot 24 &= (3x + 1) \cdot 12 \\ 192 &= 36x + 12 \\ 180 &= 36x \\ 5 &= x \end{aligned}$$

b)

$$\begin{aligned} 32 \cdot 21 &= (x - 9)(x - 13) \\ 672 &= x^2 - 22x + 117 \\ 0 &= x^2 - 22x - 555 \\ 0 &= (x - 37)(x + 15) \\ x &= 37, -15 \end{aligned}$$

However, $x \neq -15$ because length cannot be negative, so $x = 37$.

Watch this video for help with the Examples above.



MEDIA

Click image to the left for more content.

Concept Problem Revisited

Think of this as two chords intersecting each other. If we were to extend the 1.75 cm segment, it would be a diameter. So, if we find x in the diagram below and add it to 1.75 cm, we would find the diameter.

$$4.25 \cdot 4.25 = 1.75 \cdot x$$

$$18.0625 = 1.75x$$

$$x \approx 10.3 \text{ cm, making the diameter } 10.3 + 1.75 \approx 12 \text{ cm, which is the actual diameter of a CD.}$$

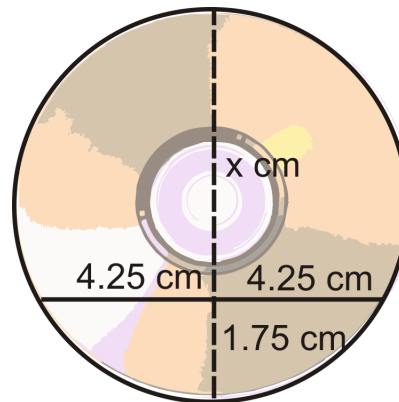

Vocabulary

A **circle** is the set of all points that are the same distance away from a specific point, called the **center**. A **radius** is the distance from the center to the circle. A **chord** is a line segment whose endpoints are on a circle. A **diameter** is a chord that passes through the center of the circle. The length of a diameter is two times the length of a radius. A **central angle** is the angle formed by two radii and whose vertex is at the center of the circle. An **inscribed angle** is an angle with its vertex on the circle and whose sides are chords. The **intercepted arc** is the arc that is inside the inscribed angle and whose endpoints are on the angle.

Guided Practice

Find x in each diagram below. Simplify any radicals.

1.

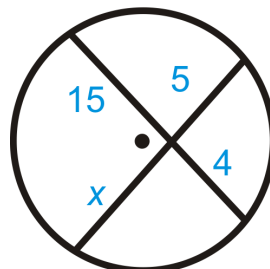

2.

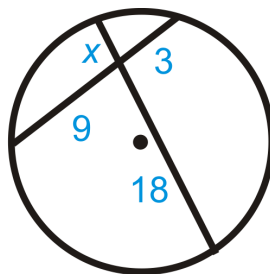

3.

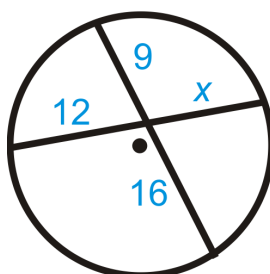
**Answers**

For all problems, use the Intersecting Chords Theorem.

1.

$$\begin{aligned} 15 \cdot 4 &= 5 \cdot x \\ 60 &= 5x \\ x &= 12 \end{aligned}$$

2.

$$\begin{aligned} 18 \cdot x &= 9 \cdot 3 \\ 18x &= 27 \\ x &= 1.5 \end{aligned}$$

3.

$$\begin{aligned} 12 \cdot x &= 9 \cdot 16 \\ 12x &= 144 \\ x &= 12 \end{aligned}$$

Practice

Answer true or false.

1. If two chords bisect one another then they are diameters.
2. Tangent lines can create chords inside circles.

3. If two chords intersect and you know the length of one chord, you will be able to find the length of the second chord.

Solve for the missing segment.

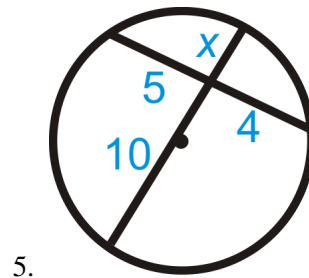
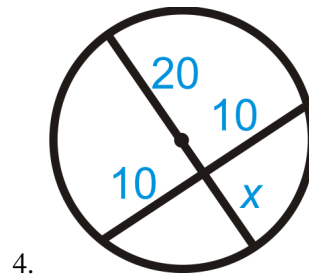

Find x in each diagram below. Simplify any radicals.

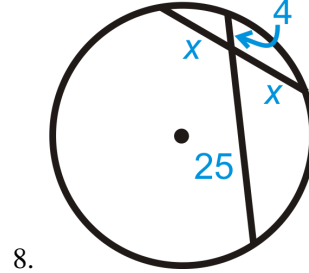
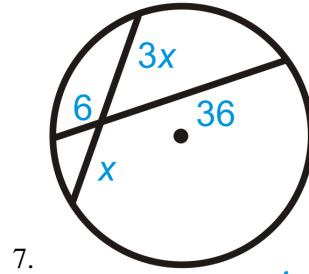
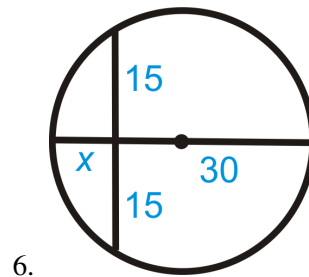

Find the value of x .

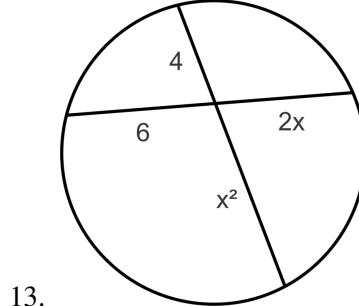
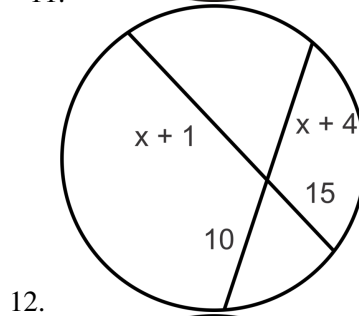
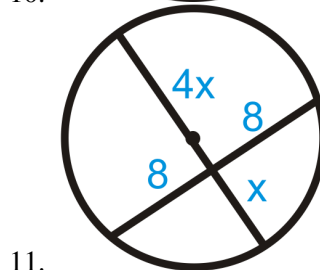
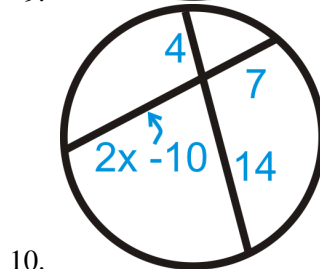
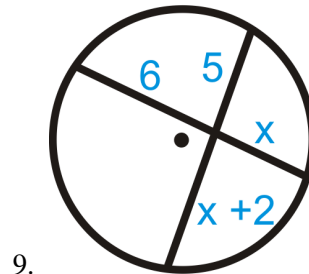

14. Suzie found a piece of a broken plate. She places a ruler across two points on the rim, and the length of the chord is 6 inches. The distance from the midpoint of this chord to the nearest point on the rim is 1 inch. Find the diameter of the plate.
15. Prove the Intersecting Chords Theorem.

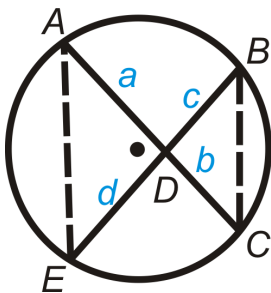

Given: Intersecting chords \overline{AC} and \overline{BE} .

Prove: $ab = cd$

9.10 Segments from Secants

Here you'll learn how to solve for missing segments from secants intersecting circles.

What if you wanted to figure out the distance from the orbiting moon to different locations on Earth? At a particular time, the moon is 238,857 miles from Beijing, China. On the same line, Yukon is 12,451 miles from Beijing. Drawing another line from the moon to Cape Horn (the southernmost point of South America), we see that Jakarta, Indonesia is collinear. If the distance from Cape Horn to Jakarta is 9849 miles, what is the distance from the moon to Jakarta? After completing this Concept, you'll be able to solve problems like this.



Watch This



MEDIA

Click image to the left for more content.

CK-12 Foundation: Chapter9SegmentsfromSecantsA

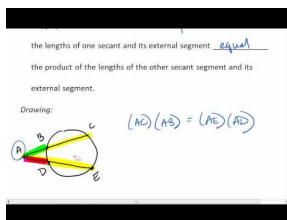

MEDIA

Click image to the left for more content.

Guidance

In addition to forming an angle outside of a circle, the circle can divide the secants into segments that are proportional with each other.

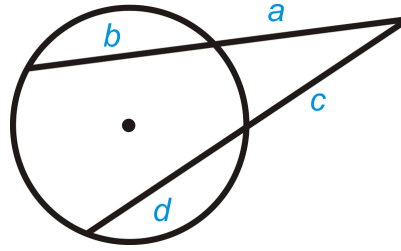

If we draw in the intersecting chords, we will have two similar triangles.

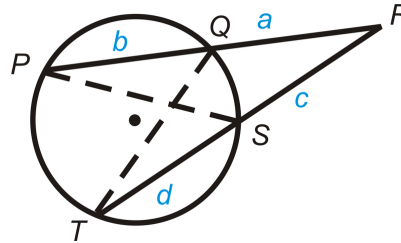

From the inscribed angles and the Reflexive Property ($\angle R \cong \angle R$), $\triangle PRS \sim \triangle TRQ$. Because the two triangles are similar, we can set up a proportion between the corresponding sides. Then, cross-multiply. $\frac{a}{c+d} = \frac{c}{a+b} \Rightarrow a(a+b) = c(c+d)$

Two Secants Segments Theorem: If two secants are drawn from a common point outside a circle and the segments are labeled as above, then $a(a+b) = c(c+d)$. In other words, the product of the outer segment and the whole of one secant is equal to the product of the outer segment and the whole of the other secant.

Example A

Find the value of the missing variable.

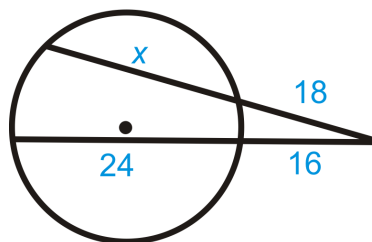

Use the Two Secants Segments Theorem to set up an equation. For both secants, you multiply the outer portion of the secant by the whole.

$$\begin{aligned} 18 \cdot (18 + x) &= 16 \cdot (16 + 24) \\ 324 + 18x &= 256 + 384 \\ 18x &= 316 \\ x &= 17\frac{5}{9} \end{aligned}$$

Example B

Find the value of the missing variable.

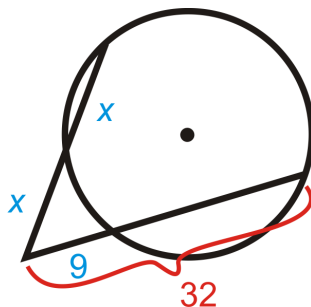

Use the Two Secants Segments Theorem to set up an equation. For both secants, you multiply the outer portion of the secant by the whole.

$$x \cdot (x + x) = 9 \cdot 32$$

$$2x^2 = 288$$

$$x^2 = 144$$

$$x = 12$$

$x \neq -12$ because length cannot be negative.

Example C

True or False: Two secants will always intersect outside of a circle.

This is false. If the two secants are parallel, they will never intersect. It's also possible for two secants to intersect inside a circle.

Watch this video for help with the Examples above.



MEDIA

Click image to the left for more content.

[CK-12 Foundation: Chapter9SegmentsfromSecantsB](#)

Concept Problem Revisited

The given information is to the left. Let's set up an equation using the Two Secants Segments Theorem.

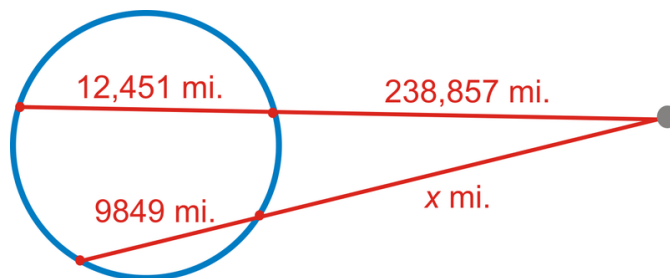

$$238857 \cdot 251308 = x \cdot (x + 9849)$$

$$60026674956 = x^2 + 9849x$$

$$0 = x^2 + 9849x - 60026674956$$

$$\text{Use the Quadratic Formula } x \approx \frac{-9849 \pm \sqrt{9849^2 - 4(-60026674956)}}{2}$$

$$x \approx 240128.4 \text{ miles}$$

Vocabulary

A **circle** is the set of all points that are the same distance away from a specific point, called the **center**. A **radius** is the distance from the center to the circle. A **chord** is a line segment whose endpoints are on a circle. A **diameter** is a chord that passes through the center of the circle. The length of a diameter is two times the length of a radius. A **central angle** is the angle formed by two radii and whose vertex is at the center of the circle. An **inscribed angle** is an angle with its vertex on the circle and whose sides are chords. The **intercepted arc** is the arc that is inside the inscribed angle and whose endpoints are on the angle. A **tangent** is a line that intersects a circle in exactly one point. The **point of tangency** is the point where the tangent line touches the circle. A **secant** is a line that intersects a circle in two points.

Guided Practice

Find x in each diagram below. Simplify any radicals.

1.

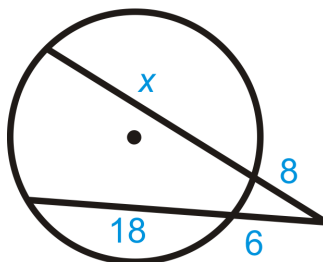

2.

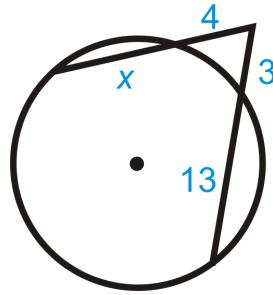

3.

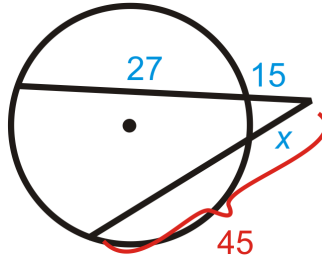
**Answers:**

Use the Two Secants Segments Theorem.

1.

$$\begin{aligned} 8(8+x) &= 6(6+18) \\ 64+8x &= 144 \\ 8x &= 80 \\ x &= 10 \end{aligned}$$

2.

$$\begin{aligned} 4(4+x) &= 3(3+13) \\ 16+4x &= 48 \\ 4x &= 32 \\ x &= 8 \end{aligned}$$

3.

$$\begin{aligned} 15(15+27) &= x \cdot 45 \\ 630 &= 45x \\ x &= 14 \end{aligned}$$

Practice

Solve for the missing segment.

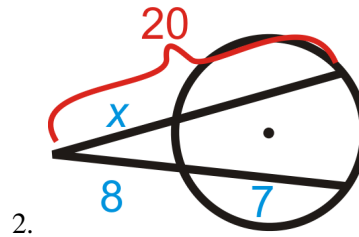
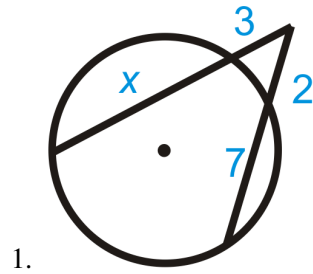

Find x in each diagram below. Simplify any radicals.

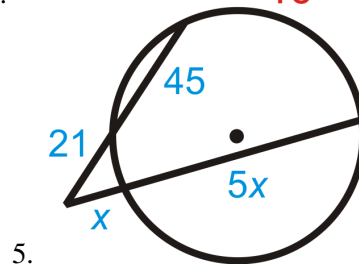
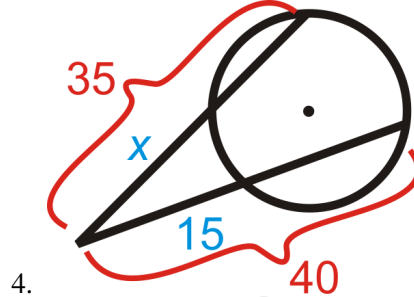
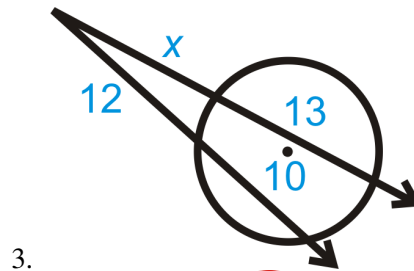

6. Prove the Two Secants Segments Theorem.

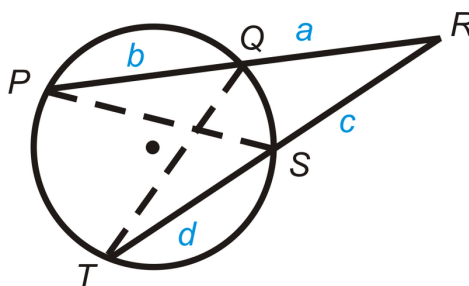

Given: Secants \overline{PR} and \overline{RT}

Prove: $a(a + b) = c(c + d)$

Solve for the unknown variable.

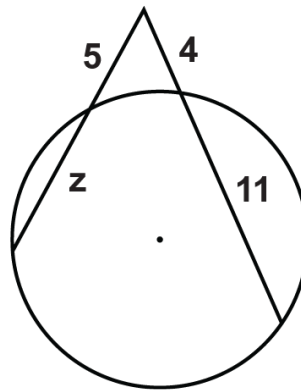

7.

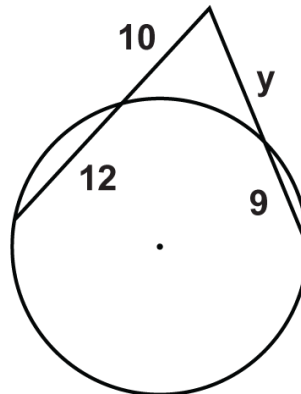

8.

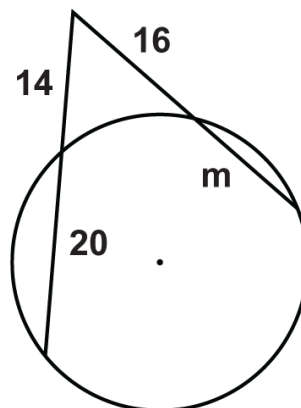

9.

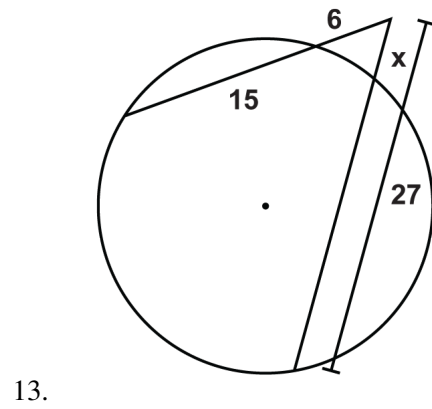
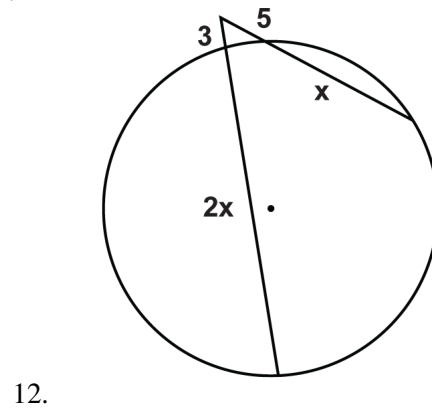
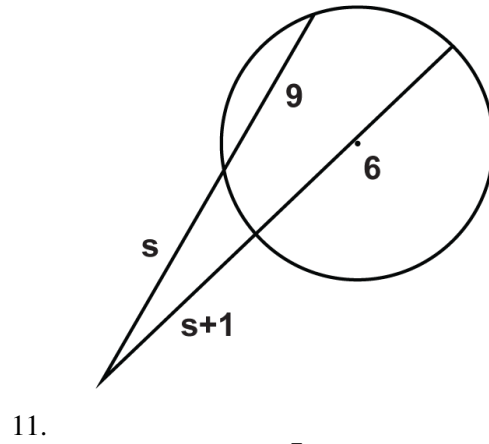
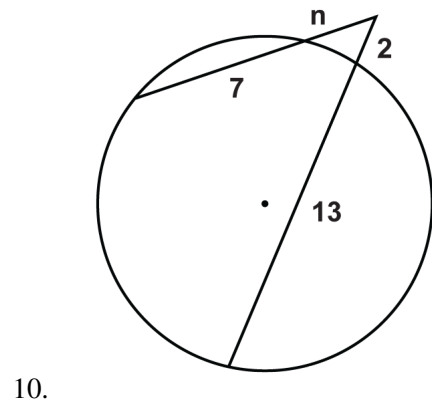

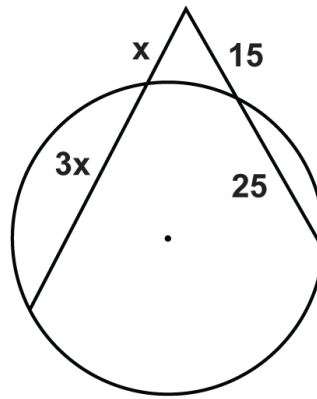

14.

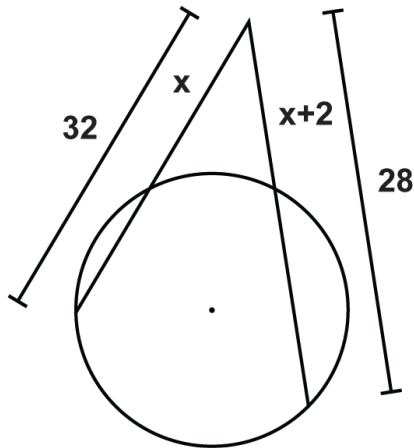

15.

9.11 Segments from Secants and Tangents

Here you'll learn how to solve for missing segments created by a tangent line and a secant line intersecting outside a circle.

What if you were given a circle with a tangent and a secant that intersect outside the circle? How could you use the length of some of the segments formed by their intersection to determine the lengths of the unknown segments? After completing this Concept, you'll be able to use the Tangent Secant Segment Theorem to solve problems like this one.

Watch This



MEDIA

Click image to the left for more content.

CK-12 Foundation: Chapter9SegmentsfromSecantsandTangentsA

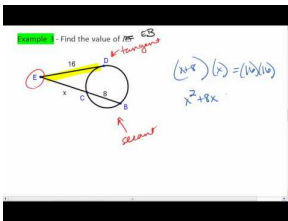

MEDIA

Click image to the left for more content.

Guidance

If a tangent and secant meet at a common point outside a circle, the segments created have a similar relationship to that of two secant rays. Recall that the product of the outer portion of a secant and the whole is equal to the same of the other secant. If one of these segments is a tangent, it will still be the product of the outer portion and the whole. However, for a tangent line, the outer portion and the whole are equal.

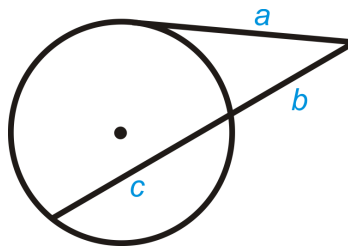

Tangent Secant Segment Theorem: If a tangent and a secant are drawn from a common point outside the circle (and the segments are labeled like the picture to the left), then $a^2 = b(b + c)$. This means that the product of the outside segment of the secant and the whole is equal to the square of the tangent segment.

Example A

Find the value of the missing segment.

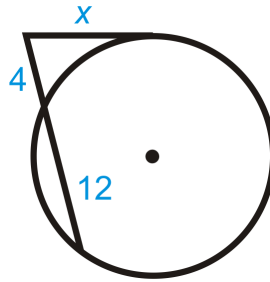

Use the Tangent Secant Segment Theorem. Square the tangent and set it equal to the outer part times the whole secant.

$$\begin{aligned}x^2 &= 4(4 + 12) \\x^2 &= 4 \cdot 16 = 64 \\x &= 8\end{aligned}$$

Example B

Find the value of the missing segment.

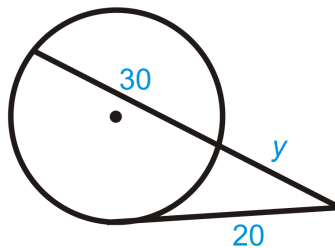

Use the Tangent Secant Segment Theorem. Square the tangent and set it equal to the outer part times the whole secant.

$$\begin{aligned}20^2 &= y(y + 30) \\400 &= y^2 + 30y \\0 &= y^2 + 30y - 400 \\0 &= (y + 40)(y - 10) \\y &= \cancel{40}, 10\end{aligned}$$

Example C

Fill in the blank and then solve for the missing segment.

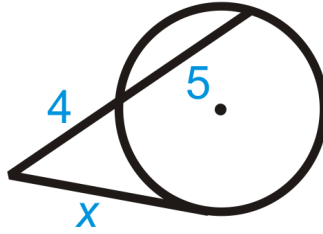

$$___ = ___(4 + 5)$$

$$x^2 = 4(4 + 5)$$

$$x^2 = 36$$

$$x = 6$$

Watch this video for help with the Examples above.



MEDIA

Click image to the left for more content.

[CK-12 Foundation: Chapter9SegmentsfromSecantsandTangentsB](#)

Vocabulary

A **circle** is the set of all points that are the same distance away from a specific point, called the **center**. A **radius** is the distance from the center to the circle. A **chord** is a line segment whose endpoints are on a circle. A **diameter** is a chord that passes through the center of the circle. The length of a diameter is two times the length of a radius. A **central angle** is the angle formed by two radii and whose vertex is at the center of the circle. An **inscribed angle** is an angle with its vertex on the circle and whose sides are chords. The **intercepted arc** is the arc that is inside the inscribed angle and whose endpoints are on the angle. A **tangent** is a line that intersects a circle in exactly one point. The **point of tangency** is the point where the tangent line touches the circle. A **secant** is a line that intersects a circle in two points.

Guided Practice

Find x in each diagram below. Simplify any radicals.

1.

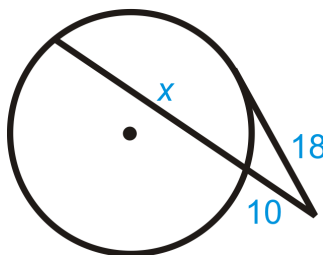

2.

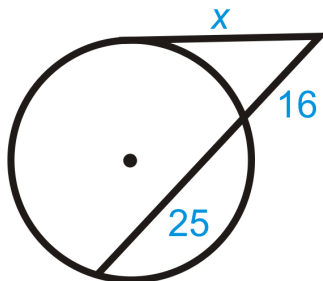

3.

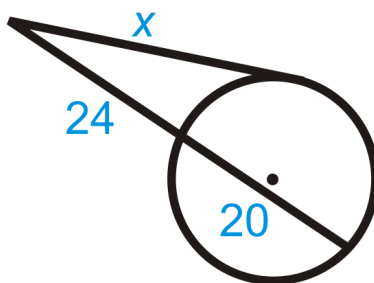
**Answers:**

Use the Tangent Secant Segment Theorem.

1.

$$18^2 = 10(10 + x)$$

$$324 = 100 + 10x$$

$$224 = 10x$$

$$x = 22.4$$

2.

$$x^2 = 16(16 + 25)$$

$$x^2 = 656$$

$$x = 4\sqrt{41}$$

3.

$$x^2 = 24(24 + 20)$$

$$x^2 = 1056$$

$$x = 4\sqrt{66}$$

Practice

Solve for the missing segment.

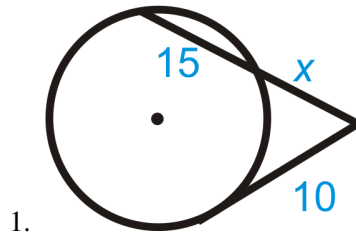

Find x in each diagram below. Simplify any radicals.

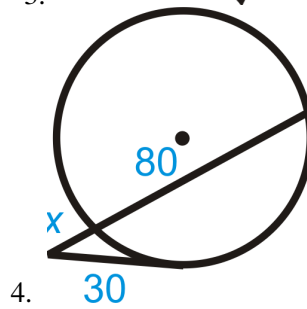
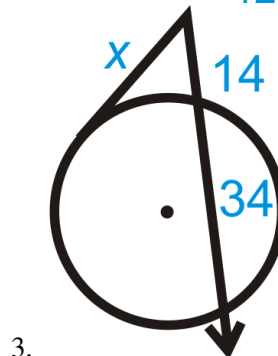
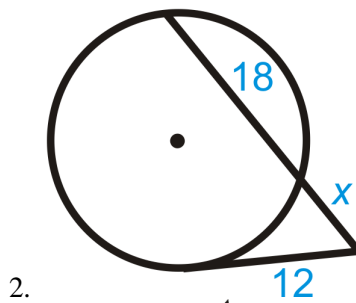

5. Describe and correct the error in finding y .

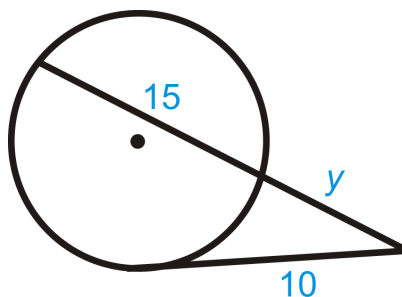

$$10 \cdot 10 = y \cdot 15y$$

$$100 = 15y^2$$

$$\frac{20}{3} = y^2$$

$$\frac{2\sqrt{15}}{3} = y \quad \leftarrow y \text{ is not correct}$$

Solve for the unknown variable.

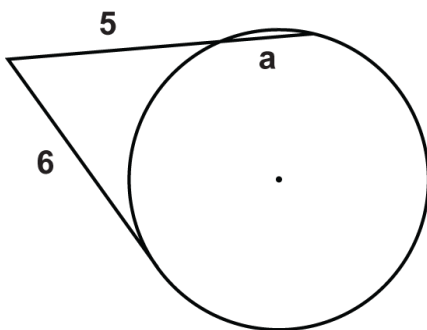

6.

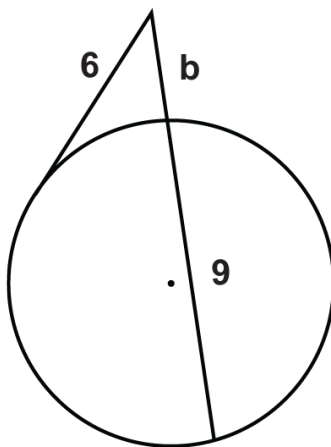

7.

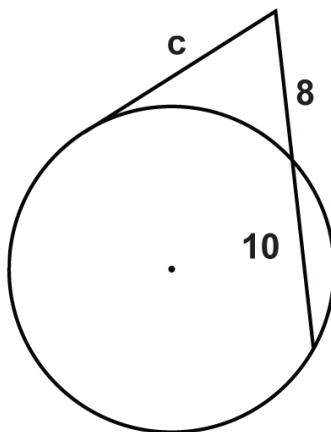

8.

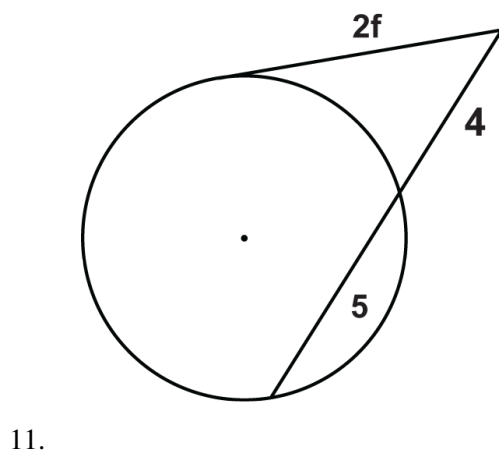
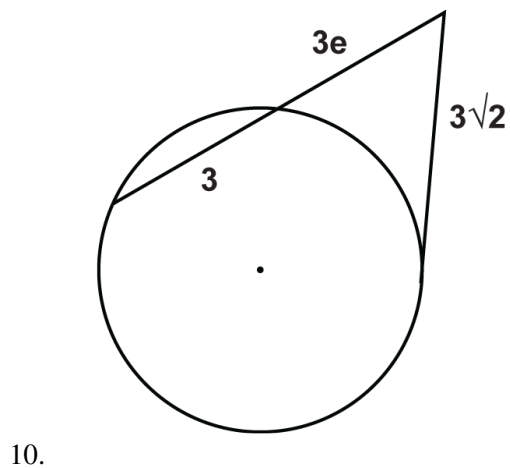
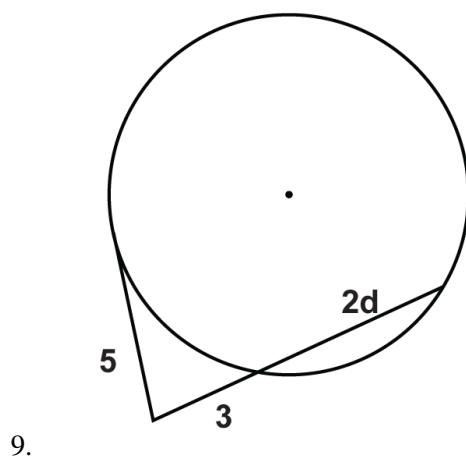

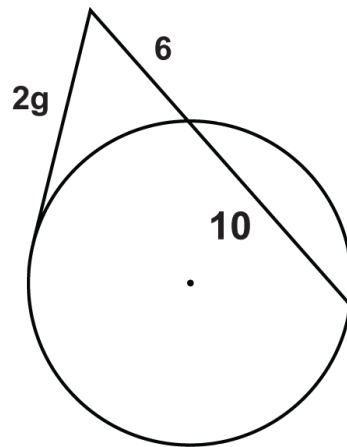

12.

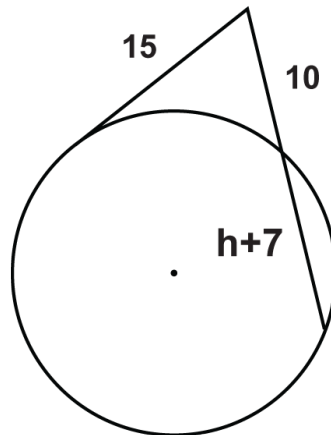

13.

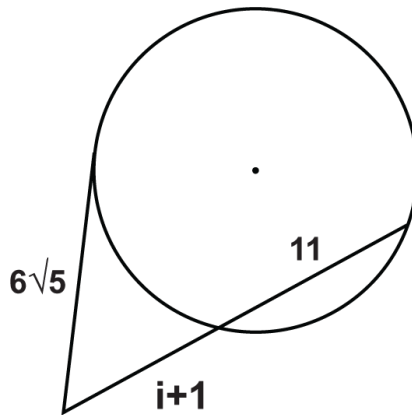

14.

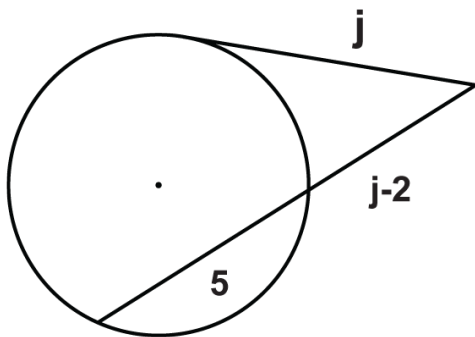

15.

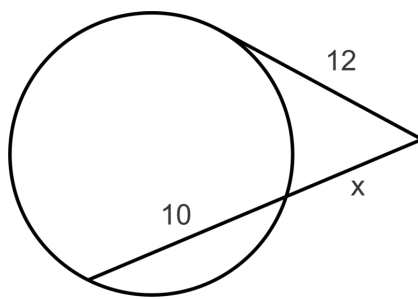

16.

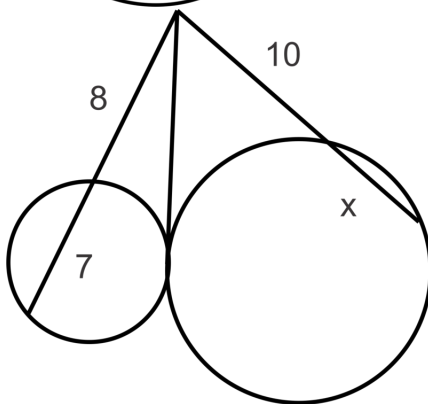

17.

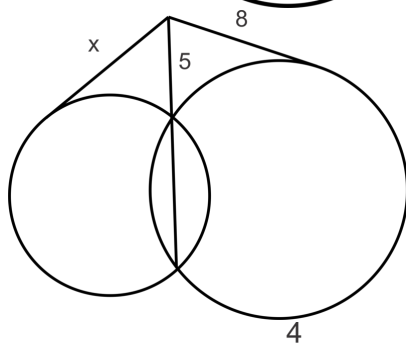

18.

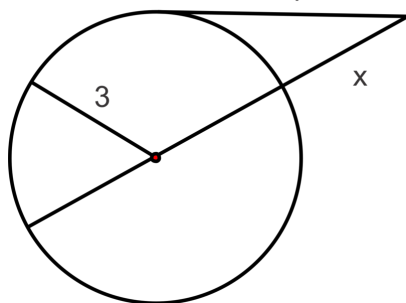

19.

20. Find x and y .

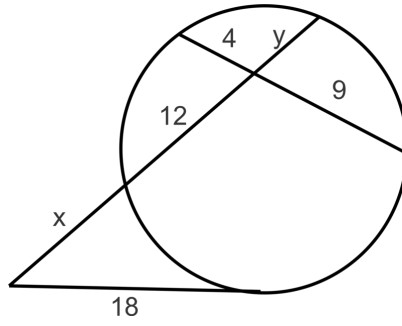

9.12 Circles in the Coordinate Plane

Here you'll learn how to find the standard equation for circles given their radius and center. You'll also graph circles in the coordinate plane.

What if you were given the length of the radius of a circle and the coordinates of its center? How could you write the equation of the circle in the coordinate plane? After completing this Concept, you'll be able to write the standard equation of a circle.

Watch This



MEDIA

Click image to the left for more content.

CK-12 Foundation: Chapter9CirclesintheCoordinatePlaneA

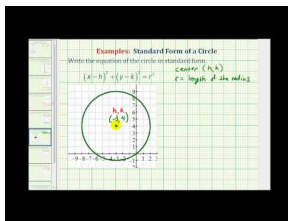

MEDIA

Click image to the left for more content.

James Sousa: Write the Standard Form of a Circle

Guidance

Recall that a circle is the set of all points in a plane that are the same distance from the center. This definition can be used to find an equation of a circle in the coordinate plane.

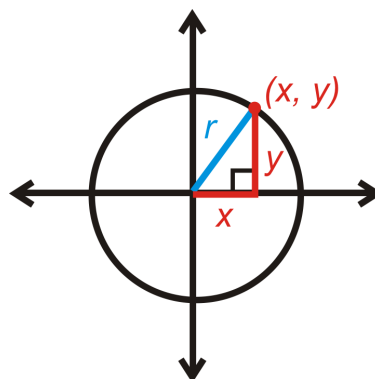

Let's start with the circle centered at $(0, 0)$. If (x, y) is a point on the circle, then the distance from the center to this point would be the radius, r . x is the horizontal distance and y is the vertical distance. This forms a right triangle. From the Pythagorean Theorem, the equation of a circle *centered at the origin* is $x^2 + y^2 = r^2$.

The center does not always have to be on $(0, 0)$. If it is not, then we label the center (h, k) . We would then use the Distance Formula to find the length of the radius.

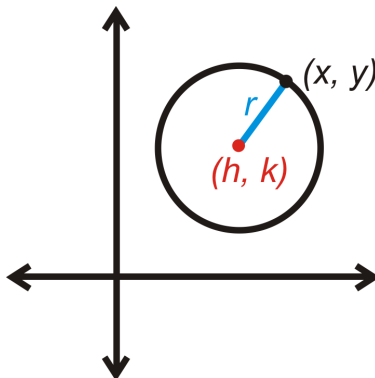

$$r = \sqrt{(x - h)^2 + (y - k)^2}$$

If you square both sides of this equation, then you would have the standard equation of a circle. **The standard equation of a circle with center (h, k) and radius r is $r^2 = (x - h)^2 + (y - k)^2$.**

Example A

Graph $x^2 + y^2 = 9$.

The center is $(0, 0)$. Its radius is the square root of 9, or 3. Plot the center, plot the points that are 3 units to the right, left, up, and down from the center and then connect these four points to form a circle.

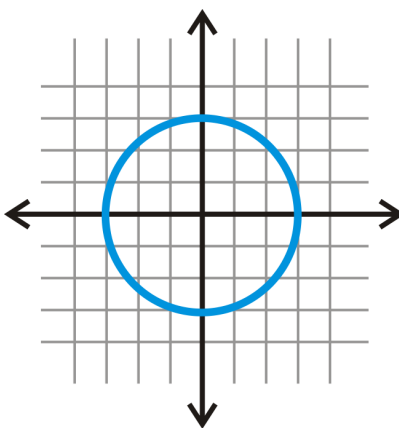

Example B

Find the equation of the circle below.

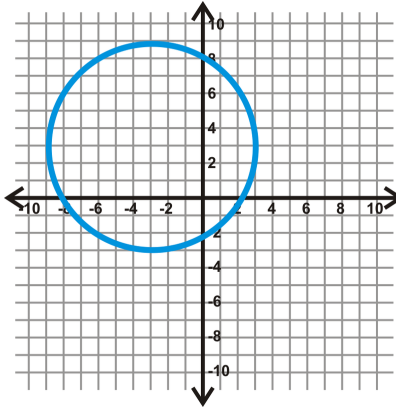

First locate the center. Draw in the horizontal and vertical diameters to see where they intersect.

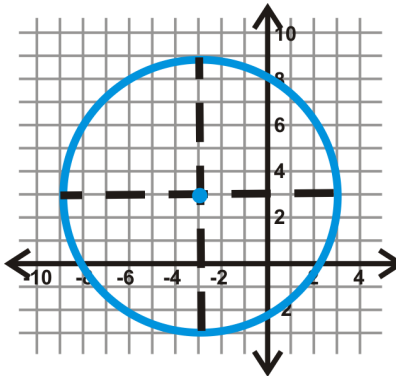

From this, we see that the center is $(-3, 3)$. If we count the units from the center to the circle on either of these diameters, we find $r = 6$. Plugging this into the equation of a circle, we get: $(x - (-3))^2 + (y - 3)^2 = 6^2$ or $(x + 3)^2 + (y - 3)^2 = 36$.

Example C

Determine if the following points are on $(x + 1)^2 + (y - 5)^2 = 50$.

a) $(8, -3)$

b) $(-2, -2)$

Plug in the points for x and y in $(x + 1)^2 + (y - 5)^2 = 50$.

a)

$$(8 + 1)^2 + (-3 - 5)^2 = 50$$

$$9^2 + (-8)^2 = 50$$

$$81 + 64 \neq 50$$

$(8, -3)$ is not on the circle

b)

$$(-2 + 1)^2 + (-2 - 5)^2 = 50$$

$$(-1)^2 + (-7)^2 = 50$$

$$1 + 49 = 50$$

$(-2, -2)$ is on the circle

Watch this video for help with the Examples above.



MEDIA

Click image to the left for more content.

[CK-12 Foundation: Chapter9CirclesintheCoordinatePlaneB](#)

Vocabulary

A **circle** is the set of all points that are the same distance away from a specific point, called the center. A **radius** is the distance from the center to the circle.

Guided Practice

Find the center and radius of the following circles.

- $(x - 3)^2 + (y - 1)^2 = 25$
- $(x + 2)^2 + (y - 5)^2 = 49$

3. Find the equation of the circle with center $(4, -1)$ and which passes through $(-1, 2)$.

Answers:

- Rewrite the equation as $(x - 3)^2 + (y - 1)^2 = 5^2$. The center is $(3, 1)$ and $r = 5$.
- Rewrite the equation as $(x - (-2))^2 + (y - 5)^2 = 7^2$. The center is $(-2, 5)$ and $r = 7$.

Keep in mind that, due to the minus signs in the formula, the coordinates of the center have the **opposite signs** of what they may initially appear to be.

3. First plug in the center to the standard equation.

$$\begin{aligned}(x - 4)^2 + (y - (-1))^2 &= r^2 \\(x - 4)^2 + (y + 1)^2 &= r^2\end{aligned}$$

Now, plug in $(-1, 2)$ for x and y and solve for r .

$$\begin{aligned}(-1 - 4)^2 + (2 + 1)^2 &= r^2 \\(-5)^2 + (3)^2 &= r^2 \\25 + 9 &= r^2 \\34 &= r^2\end{aligned}$$

Substituting in 34 for r^2 , the equation is $(x - 4)^2 + (y + 1)^2 = 34$.

Practice

Find the center and radius of each circle. Then, graph each circle.

1. $(x+5)^2 + (y-3)^2 = 16$
2. $x^2 + (y+8)^2 = 4$
3. $(x-7)^2 + (y-10)^2 = 20$
4. $(x+2)^2 + y^2 = 8$

Find the equation of the circles below.

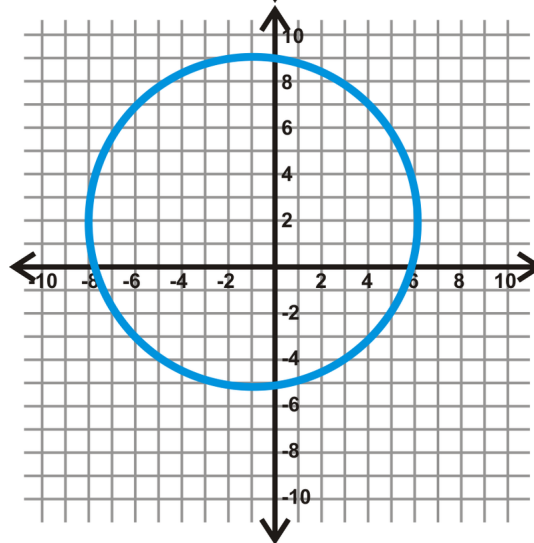
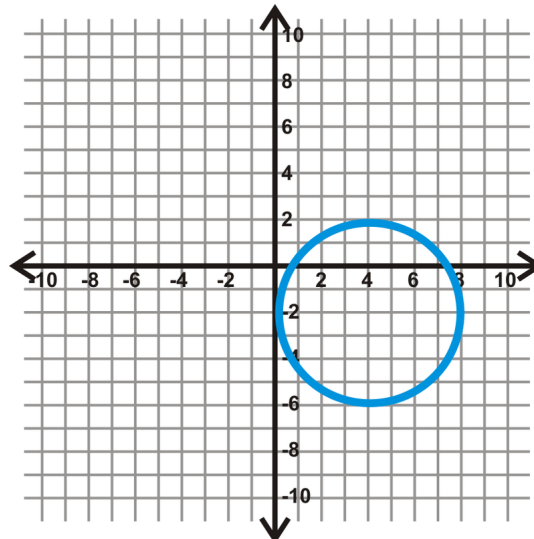

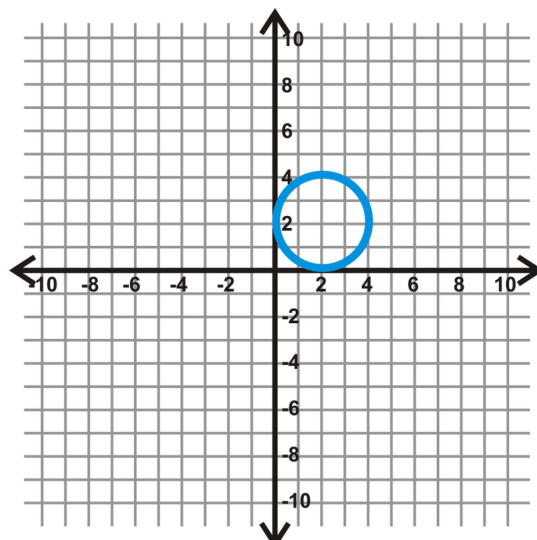

7.

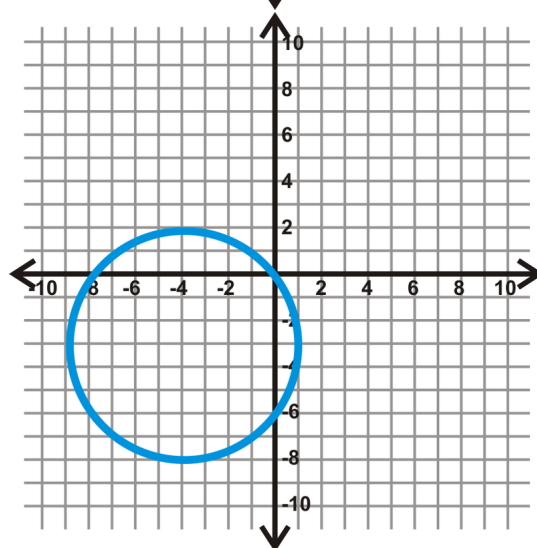

8.

9. Determine if the following points are on $(x + 1)^2 + (y - 6)^2 = 45$.
- a. (2, 0)
 - b. (-3, 4)
 - c. (-7, 3)

Find the equation of the circle with the given center and point on the circle.

- 10. center: (2, 3), point: (-4, -1)
- 11. center: (10, 0), point: (5, 2)
- 12. center: (-3, 8), point: (7, -2)
- 13. center: (6, -6), point: (-9, 4)
- 14. Now let's find the equation of a circle using three points on the circle. Given the points $A(-12, -21)$, $B(2, 27)$ and $C(19, 10)$ on the circle (an arc could be drawn through these points from A to C), follow the steps below.
 - a. Since the perpendicular bisector passes through the midpoint of a segment we must first find the midpoint between A and C .
 - b. Now the perpendicular line must have a slope that is the opposite reciprocal of the slope of \overleftrightarrow{AC} . Find the slope of \overleftrightarrow{AC} and then its opposite reciprocal.
 - c. Finally, you can write the equation of the perpendicular bisector of \overline{AC} using the point you found in part a and the slope you found in part b.
 - d. Repeat steps a-c for chord \overline{BC} .

- e. Now that we have the two perpendicular bisectors of the chord we can find their intersection. Solve the system of linear equations to find the center of the circle.
- f. Find the radius of the circle by finding the distance from the center (point found in part *e*) to any of the three given points on the circle.
- g. Now, use the center and radius to write the equation of the circle.

Find the equations of the circles which contain the three points.

15. $A(-2, 5)$, $B(5, 6)$ and $C(6, -1)$
16. $A(-11, -14)$, $B(5, 16)$ and $C(12, 9)$

Summary

This chapter begins with vocabulary associated with the parts of circles. It then branches into theorems about tangent lines; properties of arcs and central angles; and theorems about chords and how to apply them. Inscribed angles and inscribed quadrilaterals and their properties are explored. Angles on, inside, and outside a circle are presented in detail and the subsequent relationships are used in problem solving. Relationships among chords, secants, and tangents are discovered and applied. The chapter ends with the connection between algebra and geometry as the equations of circles are discussed.

Chapter Keywords

- Circle
- Center
- Radius
- Chord
- Diameter
- Secant
- Tangent
- Point of Tangency
- Congruent Circles
- Concentric Circles
- Tangent to a Circle Theorem
- Central Angle
- Arc
- Semicircle
- Minor Arc
- Major Arc
- Congruent Arcs
- Arc Addition Postulate
- Inscribed Angle
- Intercepted Arc
- Inscribed Angle Theorem
- Inscribed Polygon
- Standard Equation of a Circle

Chapter Review

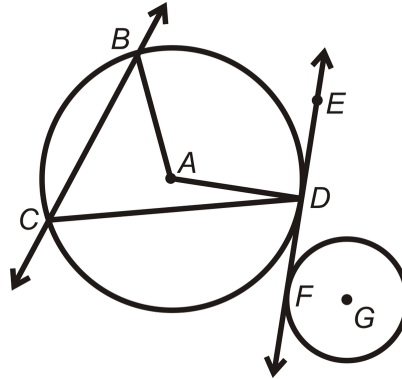

Match the description with the correct label.

1. minor arc - A. \overline{CD}
2. chord - B. \overline{AD}
3. tangent line - C. \overleftrightarrow{CB}
4. central angle - D. \overleftrightarrow{EF}
5. secant - E. A
6. radius - F. D
7. inscribed angle - G. $\angle BAD$
8. center - H. $\angle BCD$
9. major arc - I. \widehat{BD}
10. point of tangency - J. \widehat{BCD}

Texas Instruments Resources

In the CK-12 Texas Instruments Geometry FlexBook, there are graphing calculator activities designed to supplement the objectives for some of the lessons in this chapter. See <http://www.ck12.org/flexr/chapter/9694>.

Chapter Outline

- 10.1 AREA AND PERIMETER OF RECTANGLES
 - 10.2 AREA OF A PARALLELOGRAM
 - 10.3 AREA AND PERIMETER OF TRIANGLES
 - 10.4 AREA OF COMPOSITE SHAPES
 - 10.5 AREA AND PERIMETER OF TRAPEZOIDS
 - 10.6 AREA AND PERIMETER OF RHOMBUSES AND KITES
 - 10.7 AREA AND PERIMETER OF SIMILAR POLYGONS
 - 10.8 CIRCUMFERENCE
 - 10.9 ARC LENGTH
 - 10.10 AREA OF A CIRCLE
 - 10.11 AREA OF SECTORS AND SEGMENTS
 - 10.12 AREA OF REGULAR POLYGONS
-

Introduction

Now that we have explored triangles, quadrilaterals, polygons, and circles, we are going to learn how to find the perimeter and area of each. First we will derive each formula and then apply them to different types of polygons and circles. In addition, we will explore the properties of similar polygons, their perimeters and their areas.

10.1 Area and Perimeter of Rectangles

Here you'll learn how to find the area and perimeter of rectangles and squares.

What if Ed's parents were getting him a new bed, and he had to decide what size bed is best for him? Initially he decided that he would like a king bed. Upon further research, Ed discovered there are two types of king beds, an Eastern (or standard) King and a California King. The Eastern King has $76'' \times 80''$ dimensions, while the California King is $72'' \times 84''$ (both dimensions are *width* \times *length*). Which bed has a larger area to lie on? Which one has a larger perimeter? If Ed is 6'4", which bed makes more sense for him to buy? After completing this Concept, you'll be able to use your knowledge of rectangles to answer these questions.

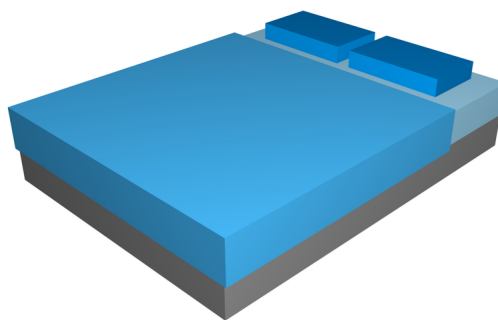

Watch This



MEDIA

Click image to the left for more content.

[CK-12 Foundation: Chapter10AreaandPerimeterofRectanglesA](#)

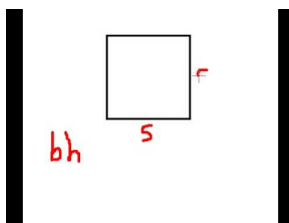

MEDIA

Click image to the left for more content.

[MathMade Easy: Finding the Areaof Rectangles](#)

Guidance

To find the **area of a rectangle** calculate the product of its base (width) and height (length) $A = bh$. The **perimeter of a rectangle** is $P = 2b + 2h$, where b is the base (or width) and h is the height (or length). If a rectangle is a

square, with sides of length s , the formula for **perimeter** is $P_{\text{square}} = 2s + 2s = 4s$ and the formula for **area** is $A_{\text{square}} = s \cdot s = s^2$.

Example A

Find the area and perimeter of a rectangle with sides 4 cm by 9 cm.

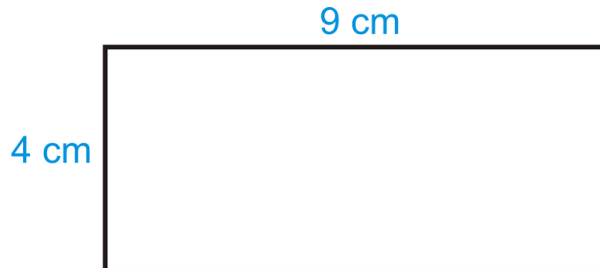

The perimeter is $4 + 9 + 4 + 9 = 26 \text{ cm}$. The area is $A = 9 \cdot 4 = 36 \text{ cm}^2$.

Example B

The area of a square is 75 in^2 . Find the perimeter.

To find the perimeter, we need to find the length of the sides.

$$A = s^2 = 75 \text{ in}^2$$

$$s = \sqrt{75} = 5\sqrt{3} \text{ in}$$

$$\text{From this, } P = 4(5\sqrt{3}) = 20\sqrt{3} \text{ in.}$$

Example C

Find the area and perimeter of a rectangle with sides 13 m and 12 m.

The perimeter is $2(13) + 2(12) = 50 \text{ m}$. The area is $13(12) = 156 \text{ m}^2$.

Watch this video for help with the Examples above.



MEDIA

Click image to the left for more content.

[CK-12 Foundation: Chapter10AreaandPerimeterofRectanglesB](#)

Concept Problem Revisited

The area of an Eastern King is 6080 in^2 and the California King is 6048 in^2 . The perimeter of both beds is 312 in. Because Ed is 6'4", he should probably get the California King because it is 4 inches longer.

Vocabulary

Perimeter is the distance around a shape. The perimeter of any figure must have a unit of measurement attached to it. If no specific units are given (feet, inches, centimeters, etc), write “units.” **Area** is the amount of space inside a figure. Area is measured in square units.

Guided Practice

1. Find the area and perimeter of a square with side 5 in.
2. Draw two different rectangles with an area of 36 cm^2 .
3. Find the area and perimeter of a rectangle with sides 7 in and 10 in.

Answers:

1. The perimeter is $4(5) = 20 \text{ in}$ and the area is $5^2 = 25 \text{ in}^2$.
2. Think of all the different factors of 36. These can all be dimensions of the different rectangles.

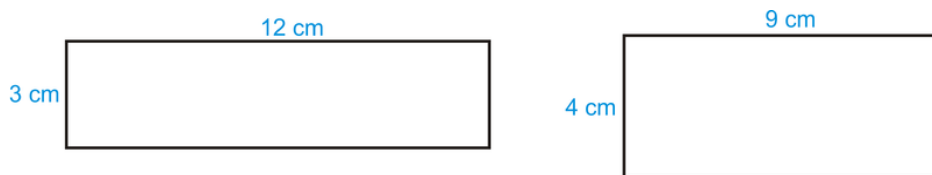

Other possibilities could be 6×6 , 2×18 , and 1×36 .

3. Area is $7(10) = 70 \text{ in}^2$. Perimeter is $2(7) + 2(10) = 34 \text{ in}$.

Practice

1. Find the area and perimeter of a square with sides of length 12 in.
2. Find the area and perimeter of a rectangle with height of 9 cm and base of 16 cm.
3. Find the area and perimeter of a rectangle if the height is 8 and the base is 14.
4. Find the area and perimeter of a square if the sides are 18 ft.
5. If the area of a square is 81 ft^2 , find the perimeter.
6. If the perimeter of a square is 24 in, find the area.
7. The perimeter of a rectangle is 32. Find two different dimensions that the rectangle could be.
8. Draw two different rectangles that have an area of 90 mm^2 .
9. True or false: For a rectangle, the bigger the perimeter, the bigger the area.
10. Find the perimeter and area of a rectangle with sides 17 in and 21 in.

For problems 11 and 12 find the dimensions of the rectangles with the given information.

11. A rectangle with a perimeter of 20 units and an area of 24 units^2 .
12. A rectangle with a perimeter of 72 units and an area of 288 units^2 .
13. A rectangle with perimeter 138 units is divided into 8 congruent rectangles as shown in the diagram below. Find the perimeter and area of one of the 8 congruent rectangles.

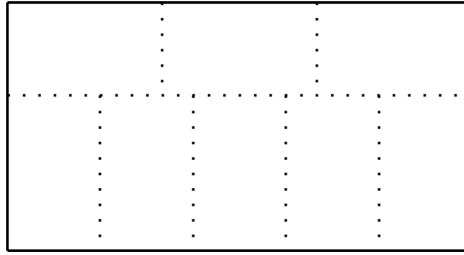

14. The length of a rectangle is 2 more than 3 times the width. The perimeter of the rectangle is 44 units. What is the area of the rectangle?
15. The length of a rectangle is 2 less than 2 times the width. The area of the rectangle is 84 units^2 . What is the perimeter of the rectangle?

10.2 Area of a Parallelogram

Here you'll learn how to find the area of a parallelogram.

What if you wanted to find the area of a parallelogram? How does the area of a parallelogram relate to the area of a rectangle? After completing this Concept, you'll be able to solve problems like these.

Watch This



MEDIA

Click image to the left for more content.

[CK-12 Foundation: Chapter10AreaofaParallelogramA](#)

Learn more about the area of parallelograms by watching the video at this link.

Guidance

Recall that a parallelogram is a quadrilateral whose opposite sides are parallel.

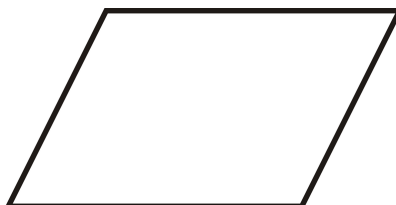

To find the area of a parallelogram, make it into a rectangle.

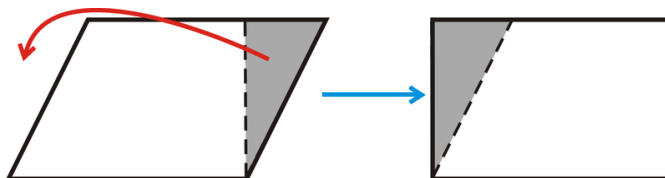

From this, we see that the area of a parallelogram is the same as the area of a rectangle. The **area of a parallelogram** is $A = bh$. Be careful! The height of a parallelogram is always perpendicular to the base. This means that the sides are *not* the height.

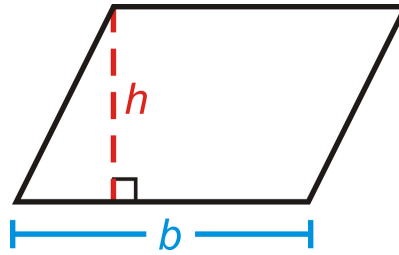
**Example A**

Find the area of the parallelogram.

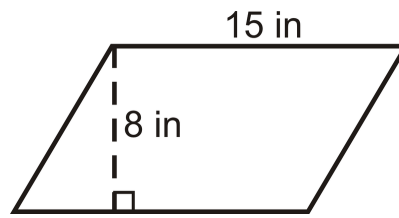

$$A = 15 \cdot 8 = 120 \text{ in}^2$$

Example B

If the area of a parallelogram is 56 units^2 and the base is 4 units, what is the height?
Plug in what we know to the area formula and solve for the height.

$$56 = 4h$$

$$14 = h$$

Example C

If the height of a parallelogram is 12 m and the area is 60 m^2 , how wide is the base?
Solve for the base in $A = bh$.

$$60 \text{ units} = 12b$$

$$5 \text{ units} = b$$

Watch this video for help with the Examples above.



MEDIA

Click image to the left for more content.

Vocabulary

Perimeter is the distance around a shape. The perimeter of any figure must have a unit of measurement attached to it. If no specific units are given (feet, inches, centimeters, etc), write “units.” **Area** is the amount of space inside a figure. Area is measured in square units. A **parallelogram** is a quadrilateral whose opposite sides are parallel.

Guided Practice

Find the area of the following shapes.

1.

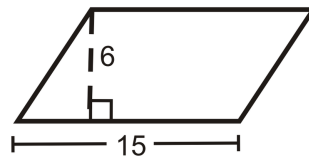

2.

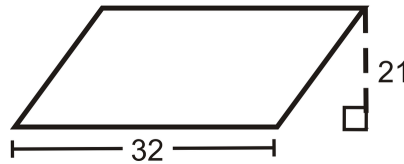

3. A parallelogram with a base of 10 m and a height of 12 m.

Answers:

1. Area is $15(6) = 90 \text{ un}^2$.
2. Area is $32(12) = 672 \text{ un}^2$.
3. Area is $10(12) = 120 \text{ m}^2$.

Practice

1. Find the area of a parallelogram with height of 20 m and base of 18 m.
2. Find the area of a parallelogram with height of 12 m and base of 15 m.
3. Find the area of a parallelogram with height of 40 m and base of 33 m.
4. Find the area of a parallelogram with height of 32 m and base of 21 m.
5. Find the area of a parallelogram with height of 25 m and base of 10 m.

Find the area of the parallelogram.

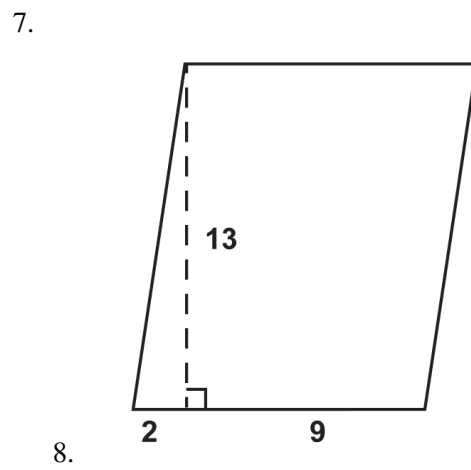
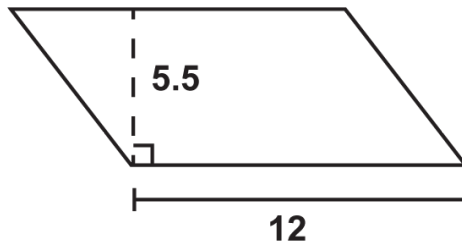
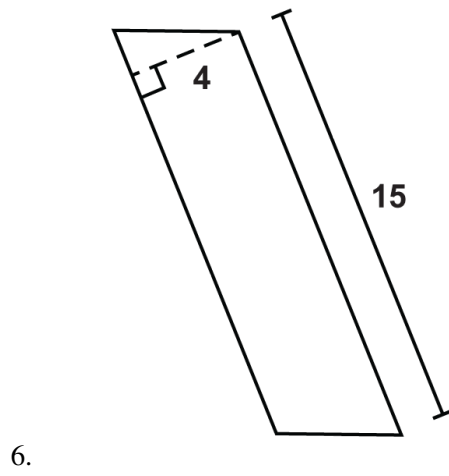

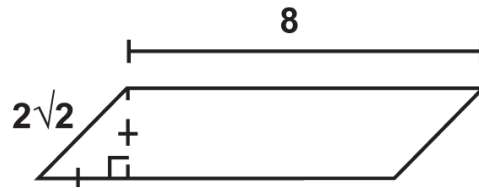

9.

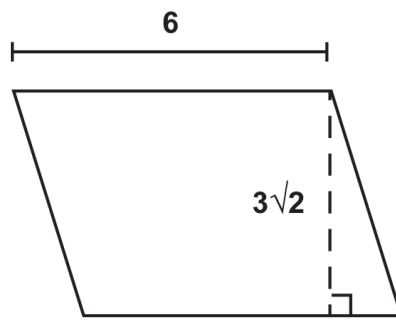

10.

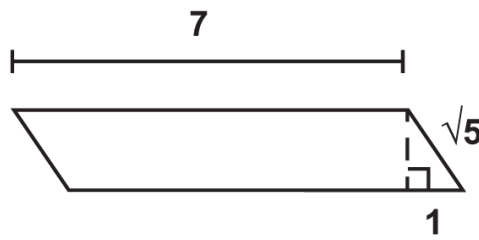

11.

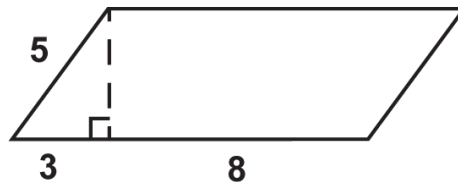

12.

13. If the area of a parallelogram is 42 units^2 and the base is 6 units, what is the height?
14. If the area of a parallelogram is 48 units^2 and the height is 6 units, what is the base?
15. If the base of a parallelogram is 9 units and the area is 108 units^2 , what is the height?
16. If the height of a parallelogram is 11 units and the area is 27.5 units^2 , what is the base?

10.3 Area and Perimeter of Triangles

Here you'll learn how to calculate the area and perimeter of a triangle and how the area of triangles relates to the area of parallelograms.

What if you wanted to find the area of a triangle? How does this relate to the area of a parallelogram? After completing this Concept, you'll be able to answer questions like these.

Watch This



MEDIA

Click image to the left for more content.

CK-12 Foundation: Chapter10AreaandPerimeterofTrianglesA

Learn more about the area of triangles by watching the video at this link.

Guidance

If we take a parallelogram and cut it in half, along a diagonal, we would have two congruent triangles. Therefore, the formula for the area of a triangle is the same as the formula for area of a parallelogram, but cut in half.

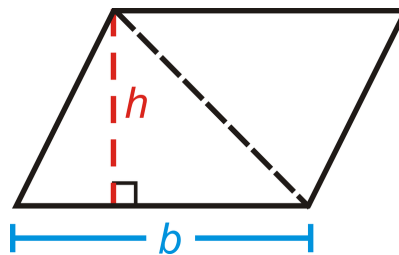

The **area of a triangle** is $A = \frac{1}{2}bh$ or $A = \frac{bh}{2}$. In the case that the triangle is a right triangle, then the height and base would be the legs of the right triangle. If the triangle is an obtuse triangle, the altitude, or height, could be outside of the triangle.

Example A

Find the area of the triangle.

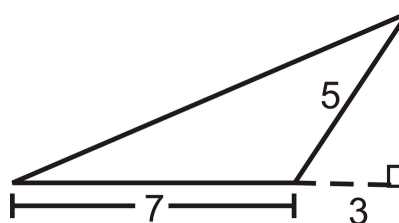

This is an obtuse triangle. To find the area, we need to find the height of the triangle. We are given the two sides of the small right triangle, where the hypotenuse is also the short side of the obtuse triangle. From these values, we see that the height is 4 because this is a 3-4-5 right triangle. The area is $A = \frac{1}{2}(4)(7) = 14 \text{ units}^2$.

Example B

Find the perimeter of the triangle from Example A.

To find the perimeter, we would need to find the longest side of the obtuse triangle. If we used the dotted lines in the picture, we would see that the longest side is also the hypotenuse of the right triangle with legs 4 and 10. Use the Pythagorean Theorem.

$$4^2 + 10^2 = c^2$$

$$16 + 100 = c^2$$

$$c = \sqrt{116} \approx 10.77 \quad \text{The perimeter is } 7 + 5 + 10.77 = 22.77 \text{ units}$$

Example C

Find the area of a triangle with base of length 28 cm and height of 15 cm.

The area is $\frac{1}{2}(28)(15) = 210 \text{ cm}^2$.

Watch this video for help with the Examples above.



MEDIA

Click image to the left for more content.

[CK-12 Foundation: Chapter10AreaandPerimeterofTrianglesB](#)

Vocabulary

Perimeter is the distance around a shape. The perimeter of any figure must have a unit of measurement attached to it. If no specific units are given (feet, inches, centimeters, etc), write “units.” **Area** is the amount of space inside a figure. Area is measured in square units.

Guided Practice

Use the triangle to answer the following questions.

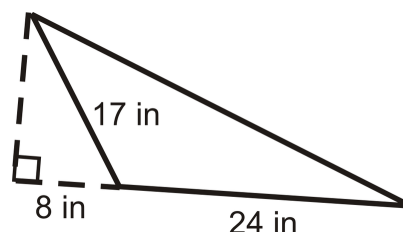

1. Find the height of the triangle.
2. Find the perimeter.
3. Find the area.

Answers:

1. Use the Pythagorean Theorem to find the height.

$$\begin{aligned}8^2 + h^2 &= 17^2 \\h^2 &= 225 \\h &= 15 \text{ in}\end{aligned}$$

2. We need to find the hypotenuse. Use the Pythagorean Theorem again.

$$\begin{aligned}(8 + 24)^2 + 15^2 &= h^2 \\h^2 &= 1249 \\h &\approx 35.3 \text{ in}\end{aligned}$$

The perimeter is $24 + 35.3 + 17 \approx 76.3 \text{ in}$.

3. The area is $\frac{1}{2}(24)(15) = 180 \text{ in}^2$.

Practice

Use the triangle to answer the following questions.

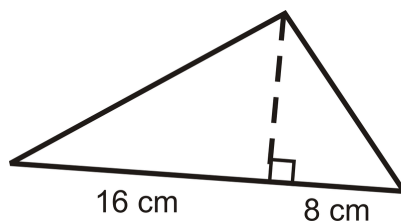

1. Find the height of the triangle by using the geometric mean.
2. Find the perimeter.
3. Find the area.

Find the area of the following shape.

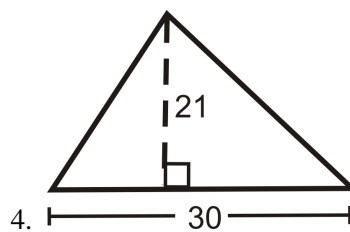

4. What is the area of a triangle with area 144 m^2 and a base of 24 m ?

For problems 6 and 7 find the height and area of the equilateral triangle with the given perimeter.

6. Perimeter 18 units.
7. Perimeter 30 units.
8. Generalize your results from problems 6 and 7 into a formula to find the height and area of an equilateral triangle with side length x .

Find the area of each triangle.

9. Find the area of a triangle with a base of 10 in and a height of 12 in.
10. Find the area of a triangle with a base of 5 in and a height of 3 in.
11. An equilateral triangle with a height of $6\sqrt{3}$ units.
12. A 45-45-90 triangle with a hypotenuse of $5\sqrt{2}$ units.
13. A 45-45-90 triangle with a leg of 12 units.
14. A 30-60-90 triangle with a hypotenuse of 24 units.
15. A 30-60-90 triangle with a short leg of 5 units.

10.4 Area of Composite Shapes

Here you'll learn how to find the area of a composite shape.

What if you wanted to find the area of a shape that was made up of other shapes? How could you use your knowledge of the area of rectangles, parallelograms, and triangles to help you? After completing this Concept, you'll be able to answer questions like these.

Watch This



MEDIA

Click image to the left for more content.

[CK-12 Foundation: Chapter10AreaofCompositeShapesA](#)

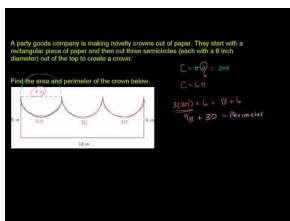

MEDIA

Click image to the left for more content.

[KhanAcademy: Area and Perimeter of Composite Figures](#)

Guidance

Perimeter is the distance around a shape. The perimeter of any figure must have a unit of measurement attached to it. If no specific units are given (feet, inches, centimeters, etc), write “units.” **Area** is the amount of space inside a figure. If two figures are congruent, they have the same area. This is the **congruent areas postulate**. This postulate needs no proof because congruent figures have the same amount of space inside them. Keep in mind that two figures with the same area are not necessarily congruent.

A **composite shape** is a shape made up of other shapes. To find the area of such a shape, simply find the area of each part and add them up. The **area addition postulate** states that if a figure is composed of two or more parts that do not overlap each other, then the area of the figure is the sum of the areas of the parts.

Example A

Find the area of the figure below. You may assume all sides are perpendicular.

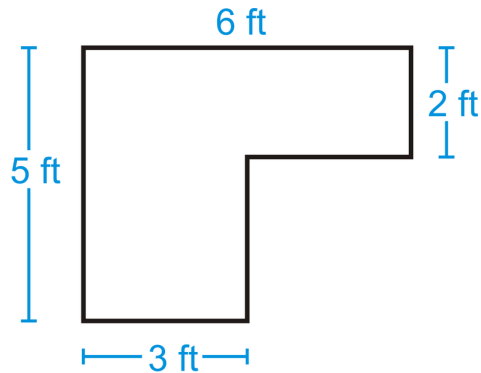

Split the shape into two rectangles and find the area of each.

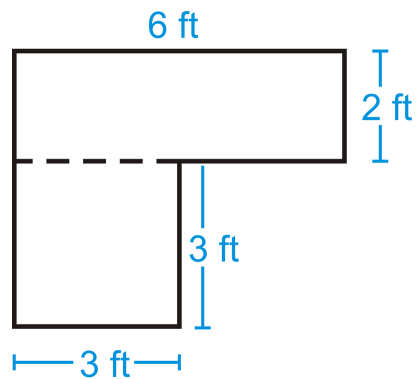

$$A_{\text{top rectangle}} = 6 \cdot 2 = 12 \text{ ft}^2$$

$$A_{\text{bottom square}} = 3 \cdot 3 = 9 \text{ ft}^2$$

The total area is $12 + 9 = 21 \text{ ft}^2$.

Example B

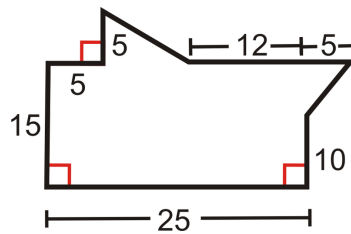

- Divide the shape into two triangles and one rectangle.
- Find the area of the two triangles and rectangle.
- Find the area of the entire shape.

Solution:

- One triangle on the top and one on the right. Rectangle is the rest.
- Area of triangle on top is $\frac{8(5)}{2} = 20 \text{ units}^2$. Area of triangle on right is $\frac{5(5)}{2} = 12.5 \text{ units}^2$. Area of rectangle is 375 units^2 .
- Total area is 407.5 units^2 .

Example C

Find the area of the figure below.

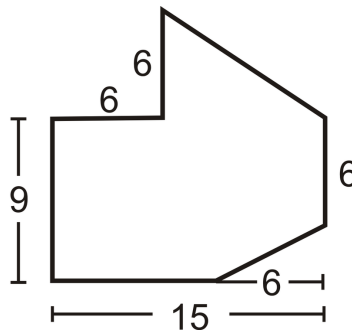

Divide the figure into a triangle and a rectangle with a small rectangle cut out of the lower right-hand corner.

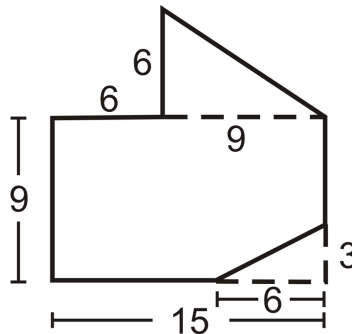

$$A = A_{\text{top triangle}} + A_{\text{rectangle}} - A_{\text{small triangle}}$$

$$A = \left(\frac{1}{2} \cdot 6 \cdot 9 \right) + (9 \cdot 15) - \left(\frac{1}{2} \cdot 3 \cdot 6 \right)$$

$$A = 27 + 135 - 9$$

$$A = 153 \text{ units}^2$$

Watch this video for help with the Examples above.



MEDIA

Click image to the left for more content.

[CK-12 Foundation: Chapter10AreaofCompositeShapesB](#)

Vocabulary

Perimeter is the distance around a shape. The perimeter of any figure must have a unit of measurement attached to it. If no specific units are given (feet, inches, centimeters, etc), write “units.” **Area** is the amount of space inside a figure and is measured in square units. A **composite shape** is a shape made up of other shapes.

Guided Practice

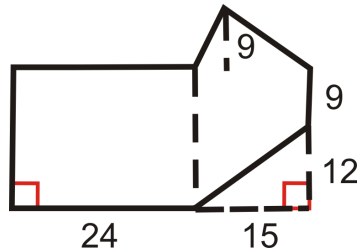

1. Find the area of the rectangles and triangle.
2. Find the area of the whole shape.

Answers:

1. Rectangle #1: Area = $24(9 + 12) = 504 \text{ units}^2$. Rectangle #2: Area = $15(9 + 12) = 315 \text{ units}^2$. Triangle: Area = $\frac{15(9)}{2} = 67.5 \text{ units}^2$.
2. You need to subtract the area of the triangle from the bottom right corner. Total Area = $504 + 315 + 67.5 - \frac{15(12)}{2} = 796.5 \text{ units}^2$

Practice

Use the picture below for questions 1-2. Both figures are squares.

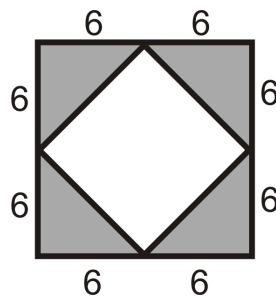

1. Find the area of the unshaded region.
2. Find the area of the shaded region.

Find the area of the figure below. You may assume all sides are perpendicular.

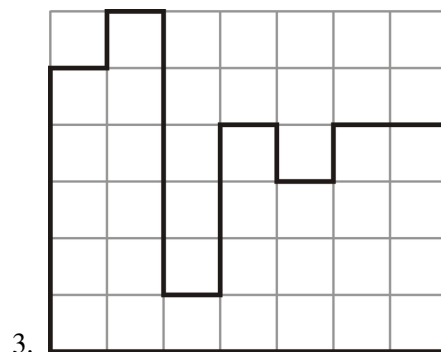

Find the areas of the composite figures.

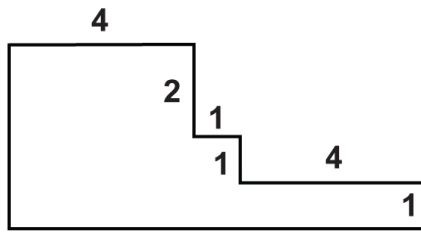

4.

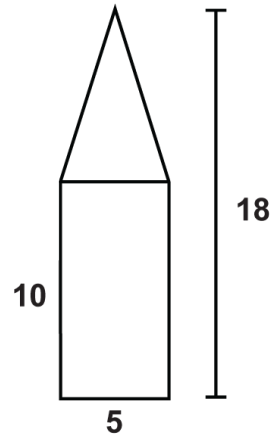

5.

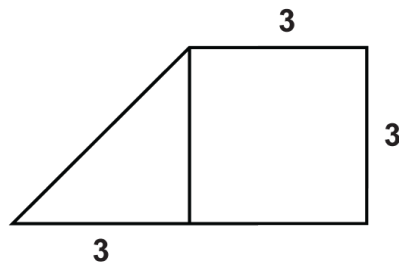

6.

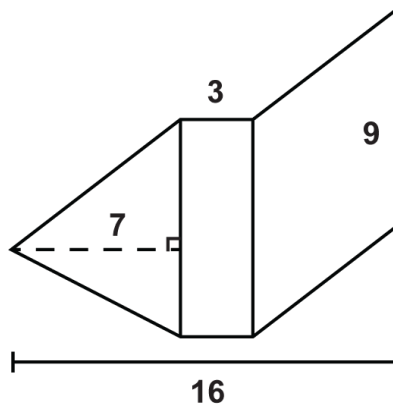

7.

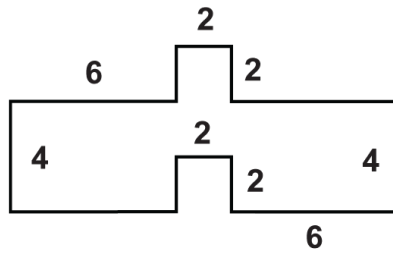

8.

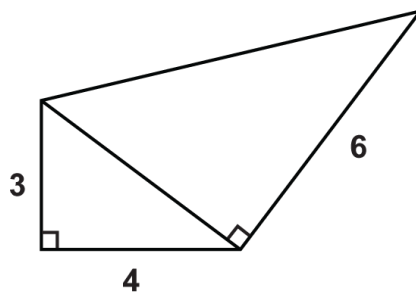

9.

Use the figure to answer the questions.

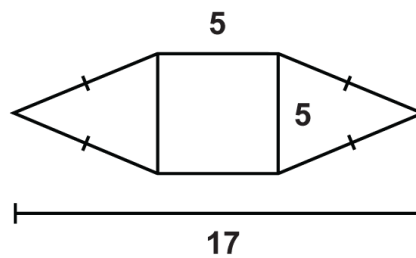

10. What is the area of the square?
11. What is the area of the triangle on the left?
12. What is the area of the composite figure?

Find the area of the following figures.

13. Find the area of the unshaded region.

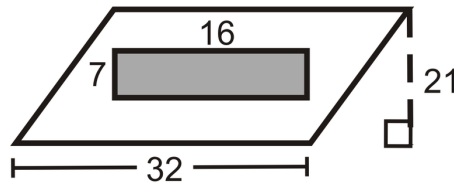

14. Lin bought a tract of land for a new apartment complex. The drawing below shows the measurements of the sides of the tract. Approximately how many acres of land did Lin buy? You may assume any angles that look like right angles are 90° . (1 acre \approx 40,000 square feet)

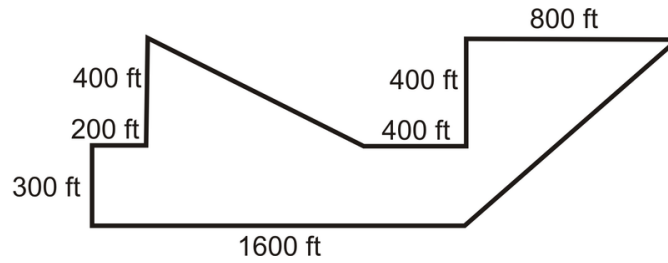

15. Linus has 100 ft of fencing to use in order to enclose a 1200 square foot rectangular pig pen. The pig pen is adjacent to the barn so he only needs to form three sides of the rectangular area as shown below. What dimensions should the pen be?

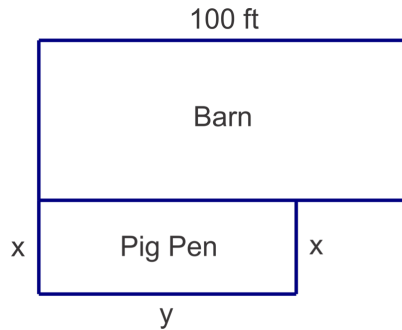

10.5 Area and Perimeter of Trapezoids

Here you'll learn how to calculate the area and perimeter of a trapezoid.

What if you were given the dimensions of a trapezoid and asked to calculate its area? How does calculating the area of a trapezoid relate to calculating the area of a parallelogram? After completing this Concept, you'll be able to answer questions like these.

Watch This



MEDIA

Click image to the left for more content.

[CK-12 Foundation: Chapter10AreaandPerimeterofTrapezoidsA](#)

Learn more about the area of trapezoids by watching the video at this link.

Guidance

Recall that a trapezoid is a quadrilateral with one pair of parallel sides. The lengths of the parallel sides are the bases. The perpendicular distance between the parallel sides is the height, or altitude, of the trapezoid.

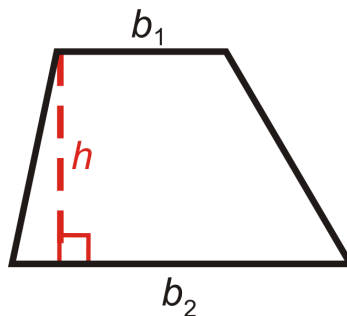

To find the area of the trapezoid, let's turn it into a parallelogram. To do this, make a copy of the trapezoid and then rotate the copy 180° . Now, this is a parallelogram with height h and base $b_1 + b_2$. Let's find the area of this shape.

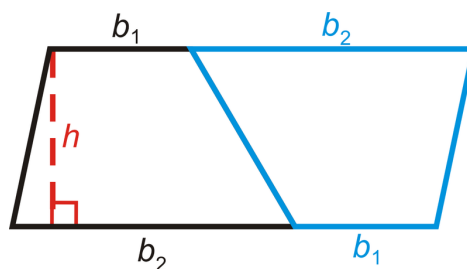

$$A = h(b_1 + b_2)$$

Because the area of this parallelogram is made up of two congruent trapezoids, the **area of one trapezoid** would be $A = \frac{1}{2}h(b_1 + b_2)$. The formula for the area of a trapezoid could also be written as *the average of the bases time the height*.

Example A

Find the area of the trapezoid below.

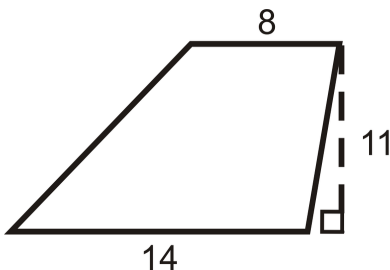

$$A = \frac{1}{2}(11)(14 + 8)$$

$$A = \frac{1}{2}(11)(22)$$

$$A = 121 \text{ units}^2$$

Example B

Find the area of the trapezoid below.

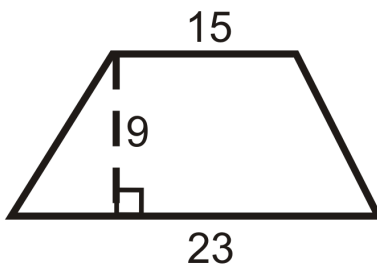

$$A = \frac{1}{2}(9)(15 + 23)$$

$$A = \frac{1}{2}(9)(38)$$

$$A = 171 \text{ units}^2$$

Example C

Find the perimeter and area of the trapezoid.

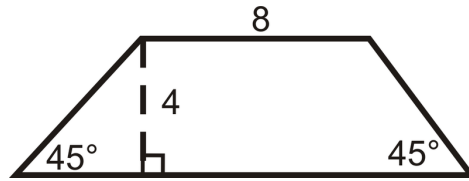

Even though we are not told the length of the second base, we can find it using special right triangles. Both triangles at the ends of this trapezoid are isosceles right triangles, so the hypotenuses are $4\sqrt{2}$ and the other legs are of length 4.

$$P = 8 + 4\sqrt{2} + 16 + 4\sqrt{2}$$

$$P = 24 + 8\sqrt{2} \approx 35.3 \text{ units}$$

$$A = \frac{1}{2}(4)(8 + 16)$$

$$A = 48 \text{ units}^2$$

Watch this video for help with the Examples above.



MEDIA

Click image to the left for more content.

[CK-12 Foundation: Chapter10AreaandPerimeterofTrapezoidsB](#)

Vocabulary

Perimeter is the distance around a shape. The perimeter of any figure must have a unit of measurement attached to it. If no specific units are given (feet, inches, centimeters, etc), write “units.” **Area** is the amount of space inside a figure. Area is measured in square units. A **trapezoid** is a quadrilateral with one pair of parallel sides.

Guided Practice

Find the area of the following shapes. Round your answers to the nearest hundredth.

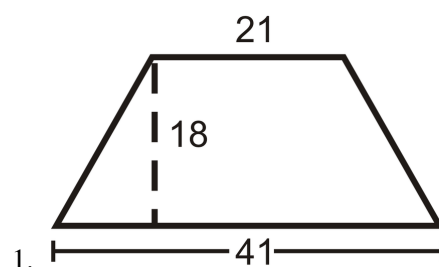

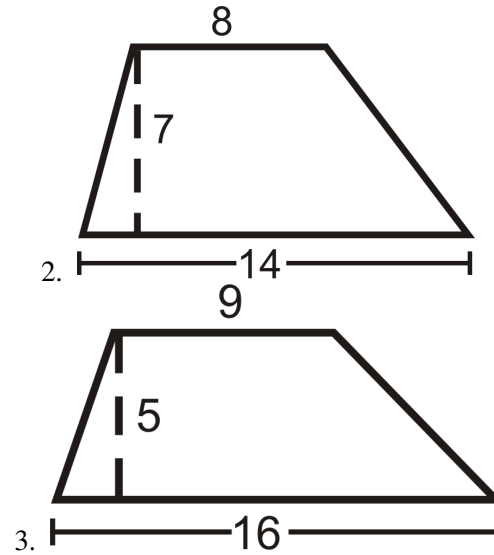

Answers

Use the formula for the area of a trapezoid.

- $\frac{1}{2}(18)(41 + 21) = 558 \text{ units}^2$.
- $\frac{1}{2}(7)(14 + 8) = 77 \text{ units}^2$.
- $\frac{1}{2}(5)(16 + 9) = 62.5 \text{ units}^2$.

Practice

Find the area and perimeter of the following shapes. Round your answers to the nearest hundredth.

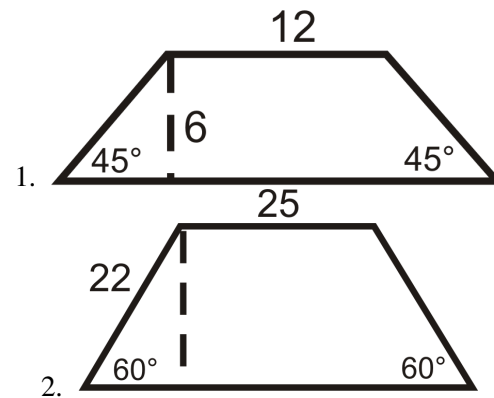

Find the area of the following trapezoids.

- Trapezoid with bases 3 in and 7 in and height of 3 in.
- Trapezoid with bases 6 in and 8 in and height of 5 in.
- Trapezoid with bases 10 in and 26 in and height of 2 in.
- Trapezoid with bases 15 in and 12 in and height of 10 in.
- Trapezoid with bases 4 in and 23 in and height of 21 in.
- Trapezoid with bases 9 in and 4 in and height of 1 in.
- Trapezoid with bases 12 in and 8 in and height of 16 in.
- Trapezoid with bases 26 in and 14 in and height of 19 in.

Use the given figures to answer the questions.

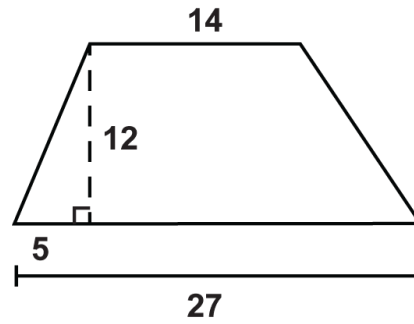

11. What is the perimeter of the trapezoid?
12. What is the area of the trapezoid?

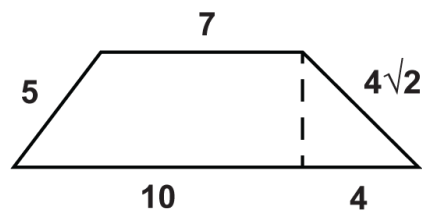

13. What is the perimeter of the trapezoid?
14. What is the area of the trapezoid?

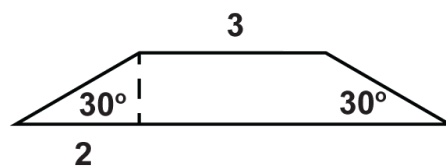

15. What is the perimeter of the trapezoid?
16. What is the area of the trapezoid?

17. Use the isosceles trapezoid to show that the area of this trapezoid can also be written as the sum of the area of the two triangles and the rectangle in the middle. Write the formula and then reduce it to equal $\frac{1}{2}h(b_1 + b_2)$ or $\frac{h}{2}(b_1 + b_2)$.

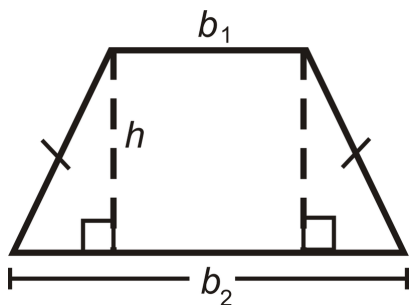

18. Quadrilateral $ABCD$ has vertices $A(-2,0)$, $B(0,2)$, $C(4,2)$, and $D(0,-2)$. Show that $ABCD$ is a trapezoid and find its area. *Leave your answer in simplest radical form.*

10.6 Area and Perimeter of Rhombuses and Kites

Here you'll learn how to calculate the area and perimeter of rhombuses and kites.

What if you wanted to find the areas of different shapes on the Brazilian flag, pictured below? The flag has dimensions of 20×14 (units vary depending on the size, so we will not use any here). The vertices of the yellow rhombus in the middle are 1.7 units from the midpoint of each side.



Find the total area of the flag and the area of the rhombus (including the circle). *Do not round your answers.* After completing this Concept, you'll be able to answer this question using your knowledge of rhombuses.

Watch This



MEDIA

Click image to the left for more content.

[CK-12 Foundation: Chapter10AreaandPerimeterofRhombusesandKitesA](#)

Learn more about the area of kites and rhombuses by watching the video at this link.

Guidance

Recall that a rhombus is an equilateral quadrilateral and a kite has adjacent congruent sides. Both of these quadrilaterals have perpendicular diagonals, which is how we are going to find their areas.

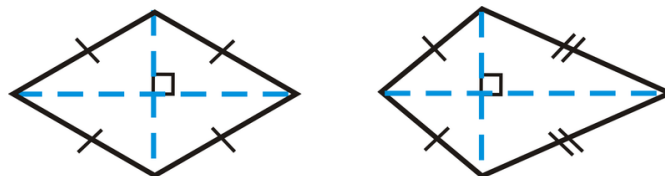

Notice that the diagonals divide each quadrilateral into 4 triangles. In the rhombus, all 4 triangles are congruent and in the kite there are two sets of congruent triangles. If we move the two triangles on the bottom of each quadrilateral so that they match up with the triangles above the horizontal diagonal, we would have two rectangles.

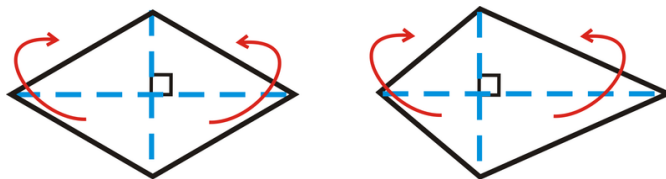

So, the height of these rectangles is half of one of the diagonals and the base is the length of the other diagonal.

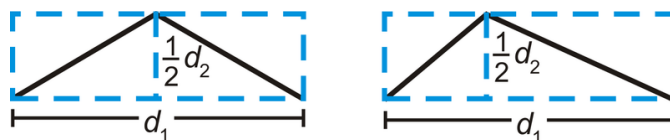

The **area of a rhombus or a kite** is $A = \frac{1}{2}d_1d_2$ if the diagonals of the rhombus or kite are d_1 and d_2 . You could also say that the area of a kite and rhombus are *half the product of the diagonals*.

Example A

Find the perimeter and area of the rhombus below.

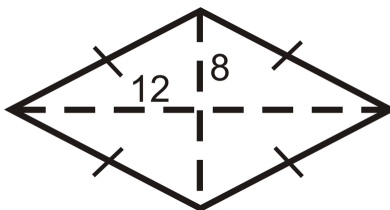

In a rhombus, all four triangles created by the diagonals are congruent. To find the perimeter, you must find the length of each side, which would be the hypotenuse of one of the four triangles. Use the Pythagorean Theorem.

$$12^2 + 8^2 = \textit{side}^2$$

$$144 + 64 = \textit{side}^2$$

$$\textit{side} = \sqrt{208} = 4\sqrt{13}$$

$$P = 4(4\sqrt{13}) = 16\sqrt{13}$$

$$A = \frac{1}{2} \cdot 16 \cdot 24$$

$$A = 192$$

Example B

Find the perimeter and area of the rhombus below.

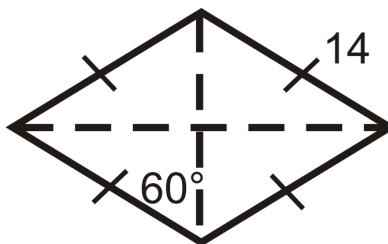

In a rhombus, all four triangles created by the diagonals are congruent.

Here, each triangle is a 30-60-90 triangle with a hypotenuse of 14. From the special right triangle ratios the short leg is 7 and the long leg is $7\sqrt{3}$.

$$P = 4 \cdot 14 = 56 \qquad A = \frac{1}{2} \cdot 7 \cdot 7\sqrt{3} = \frac{49\sqrt{3}}{2} \approx 42.44$$

Example C

The vertices of a quadrilateral are $A(2, 8)$, $B(7, 9)$, $C(11, 2)$, and $D(3, 3)$. Determine the type of quadrilateral and find its area.

For this problem, it might be helpful to plot the points. From the graph we can see this is probably a kite. Upon further review of the sides, $AB = AD$ and $BC = DC$ (you can do the distance formula to verify). Let's see if the diagonals are perpendicular by calculating their slopes.

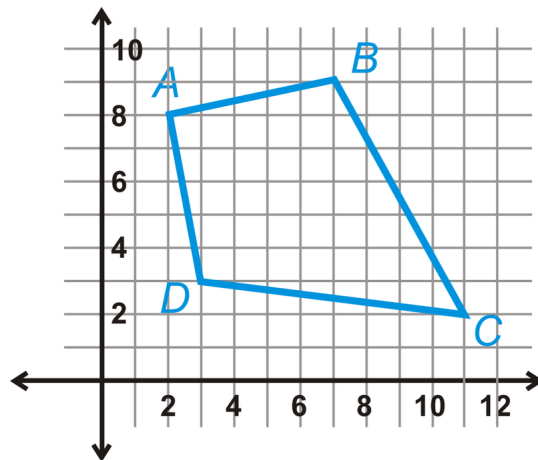

$$m_{AC} = \frac{2-8}{11-2} = -\frac{6}{9} = -\frac{2}{3}$$

$$m_{BD} = \frac{9-3}{7-3} = \frac{6}{4} = \frac{3}{2}$$

Yes, the diagonals are perpendicular because the slopes are opposite signs and reciprocals. $ABCD$ is a kite. To find the area, we need to find the length of the diagonals. Use the distance formula.

$$\begin{aligned} d_1 &= \sqrt{(2-11)^2 + (8-2)^2} & d_2 &= \sqrt{(7-3)^2 + (9-3)^2} \\ &= \sqrt{(-9)^2 + 6^2} & &= \sqrt{4^2 + 6^2} \\ &= \sqrt{81 + 36} = \sqrt{117} = 3\sqrt{13} & &= \sqrt{16 + 36} = \sqrt{52} = 2\sqrt{13} \end{aligned}$$

Now, plug these lengths into the area formula for a kite.

$$A = \frac{1}{2} (3\sqrt{13}) (2\sqrt{13}) = 39 \text{ units}^2$$

Watch this video for help with the Examples above.



MEDIA

Click image to the left for more content.

CK-12 Foundation: Chapter10AreaandPerimeterofRhombusesandKitesB

Concept Problem Revisited

The total area of the Brazilian flag is $A = 14 \cdot 20 = 280 \text{ units}^2$. To find the area of the rhombus, we need to find the length of the diagonals. One diagonal is $20 - 1.7 - 1.7 = 16.6 \text{ units}$ and the other is $14 - 1.7 - 1.7 = 10.6 \text{ units}$. The area is $A = \frac{1}{2}(16.6)(10.6) = 87.98 \text{ units}^2$.

Vocabulary

Perimeter is the distance around a shape. The perimeter of any figure must have a unit of measurement attached to it. If no specific units are given (feet, inches, centimeters, etc), write “units.” **Area** is the amount of space inside a figure. Area is measured in square units. A **rhombus** is a quadrilateral with four congruent sides and a **kite** is a quadrilateral with distinct adjacent congruent sides.

Guided Practice

Find the perimeter and area of the kites below.

1.

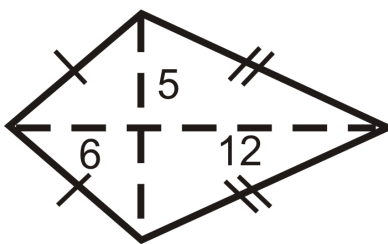

2.

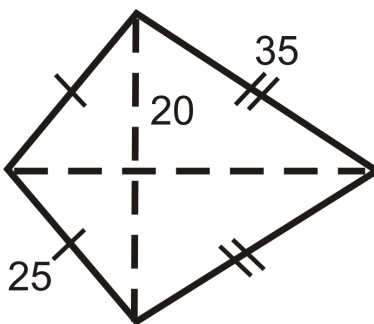

3. Find the area of a rhombus with diagonals of 6 in and 8 in.

Answers:

In a kite, there are two pairs of congruent triangles. You will need to use the Pythagorean Theorem in both problems to find the length of sides or diagonals.

- 1.

Shorter sides of kite

$$6^2 + 5^2 = s_1^2$$

$$36 + 25 = s_1^2$$

$$s_1 = \sqrt{61}$$

$$P = 2(\sqrt{61}) + 2(13) = 2\sqrt{61} + 26 \approx 41.6$$

$$A = \frac{1}{2}(10)(18) = 90$$

Longer sides of kite

$$12^2 + 5^2 = s_2^2$$

$$144 + 25 = s_2^2$$

$$s_2 = \sqrt{169} = 13$$

- 2.

Smaller diagonal portion

$$20^2 + d_s^2 = 25^2$$

$$d_s^2 = 225$$

$$d_s = 15$$

$$P = 2(25) + 2(35) = 120$$

$$A = \frac{1}{2}(15 + 5\sqrt{33})(40) \approx 874.5$$

Larger diagonal portion

$$20^2 + d_l^2 = 35^2$$

$$d_l^2 = 825$$

$$d_l = 5\sqrt{33}$$

3. The area is $\frac{1}{2}(8)(6) = 24 \text{ in}^2$.

Practice

- Do you think all rhombi and kites with the same diagonal lengths have the same area? *Explain* your answer.
- Use this picture of a rhombus to show that the area of a rhombus is equal to the sum of the areas of the four congruent triangles. Write a formula and reduce it to equal $\frac{1}{2}d_1d_2$.

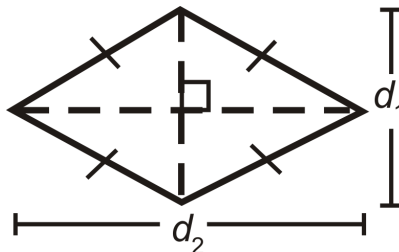

- Use this picture of a kite to show that the area of a kite is equal to the sum of the areas of the two pairs of congruent triangles. Recall that d_1 is bisected by d_2 . Write a formula and reduce it to equal $\frac{1}{2}d_1d_2$.

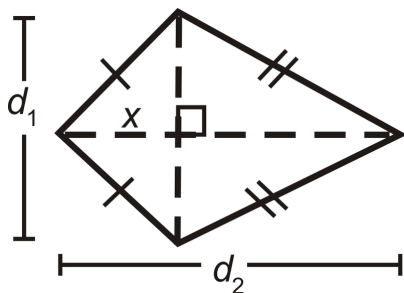

4. The area of a kite is 54 units^2 . What are two possibilities for the lengths of the diagonals?
5. Sherry designed the logo for a new company. She used three congruent kites. What is the area of the entire logo?

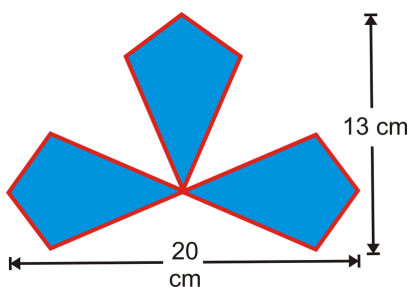

For problems 6-8, determine what kind of quadrilateral $ABCD$ is and find its area.

6. $A(-2, 2), B(5, 6), C(6, -2), D(-1, -6)$
7. Given that the lengths of the diagonals of a kite are in the ratio 4:7 and the area of the kite is 56 square units, find the lengths of the diagonals.
8. Given that the lengths of the diagonals of a rhombus are in the ratio 3:4 and the area of the rhombus is 54 square units, find the lengths of the diagonals.
9. Sasha drew this plan for a wood inlay he is making. 10 is the length of the slanted side and 16 is the length of the horizontal line segment as shown in the diagram. Each shaded section is a rhombus. What is the total area of the shaded sections?

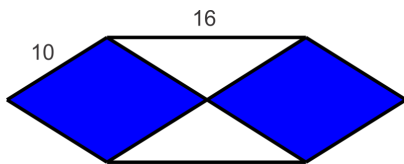

10. In the figure to the right, $ABCD$ is a square. $AP = PB = BQ$ and $DC = 20 \text{ ft}$.
 - a. What is the area of $PBQD$?
 - b. What is the area of $ABCD$?
 - c. What fractional part of the area of $ABCD$ is $PBQD$?

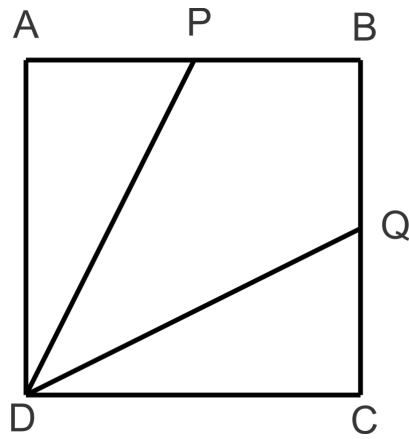

11. In the figure to the right, $ABCD$ is a square. $AP = 20$ ft and $PB = BQ = 10$ ft.
- What is the area of $PBQD$?
 - What is the area of $ABCD$?
 - What fractional part of the area of $ABCD$ is $PBQD$?

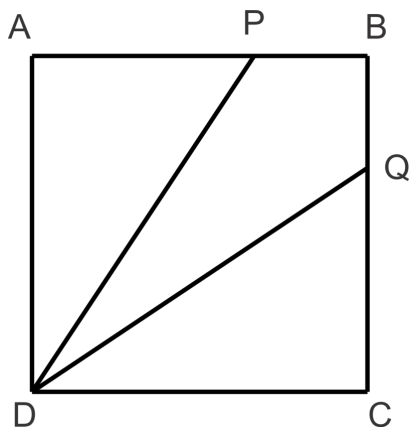

Find the area of the following shapes. Round your answers to the nearest hundredth.

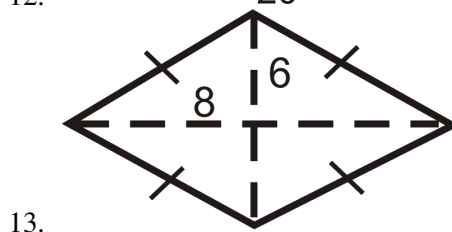
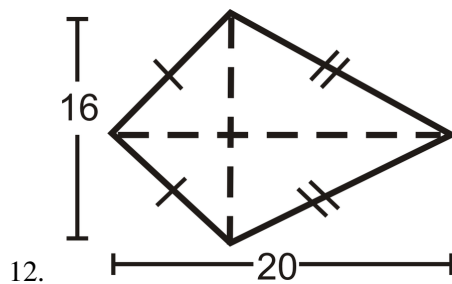

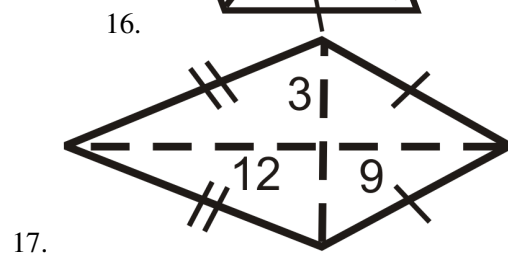
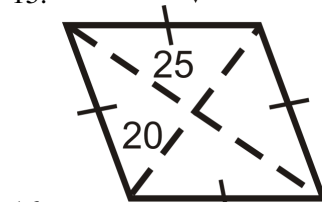
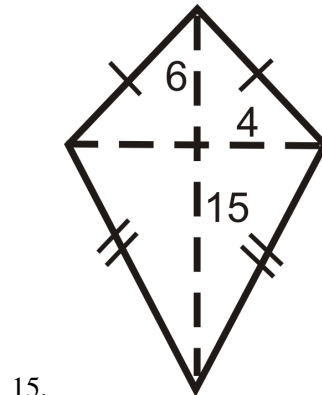
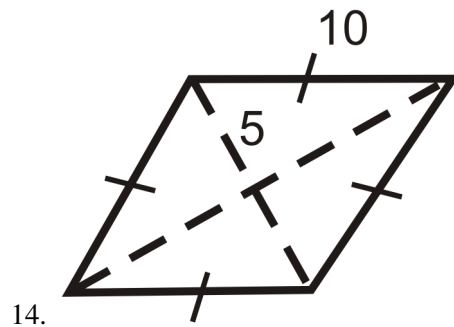

Find the area and perimeter of the following shapes. Round your answers to the nearest hundredth.

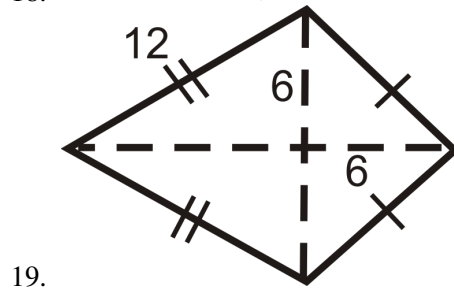
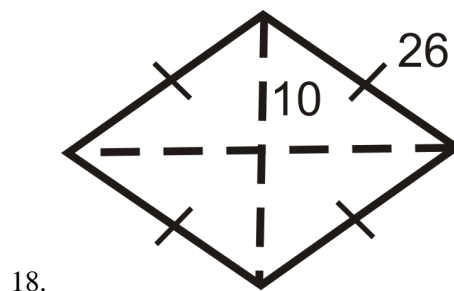

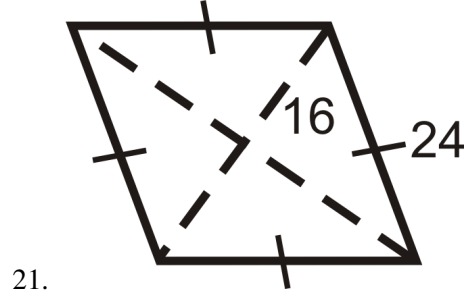
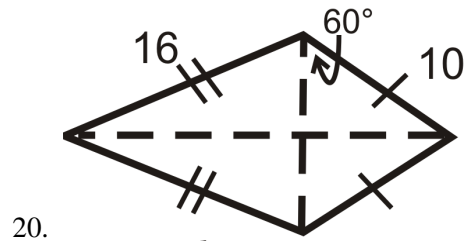

10.7 Area and Perimeter of Similar Polygons

Here you'll learn how to calculate the area and perimeter of similar polygons using ratios.

What if you wanted to create a scale drawing using scale factors? This technique takes a small object, like the handprint below, divides it up into smaller squares and then blows up the individual squares. Either trace your hand or stamp it on a piece of paper. Then, divide your hand into 9 squares, like the one to the right, probably $2\text{ in} \times 2\text{ in}$. Take a larger piece of paper and blow up each square to be $6\text{ in} \times 6\text{ in}$ (meaning you need at least an 18 in square piece of paper). Once you have your $6\text{ in} \times 6\text{ in}$ squares drawn, use the proportions and area to draw in your enlarged handprint. After completing this Concept, you'll be able to explain the results of this technique.

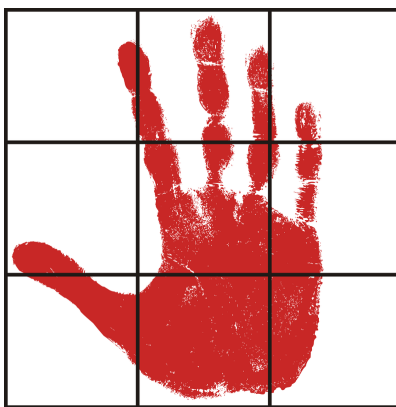

Watch This



MEDIA

Click image to the left for more content.

CK-12 Foundation: [Chapter10AreaandPerimeterofSimilarPolygonsA](#)

Watch more about similarity and area ratios by watching the video at this link.

Guidance

Polygons are similar when the corresponding angles are equal and the corresponding sides are in the same proportion. The scale factor for the sides of two similar polygons is the same as the ratio of the perimeters. In fact, the ratio of any part of two similar shapes (diagonals, medians, midsegments, altitudes, etc.) is the same as the scale factor. The ratio of the areas is the *square* of the scale factor. An easy way to remember this is to think about the units of area, which are always *squared*. Therefore, you would always *square* the scale factor to get the ratio of the areas.

Area of Similar Polygons Theorem: If the scale factor of the sides of two similar polygons is $\frac{m}{n}$, then the ratio of the areas would be $\left(\frac{m}{n}\right)^2$.

Example A

The two rectangles below are similar. Find the scale factor and the ratio of the perimeters.

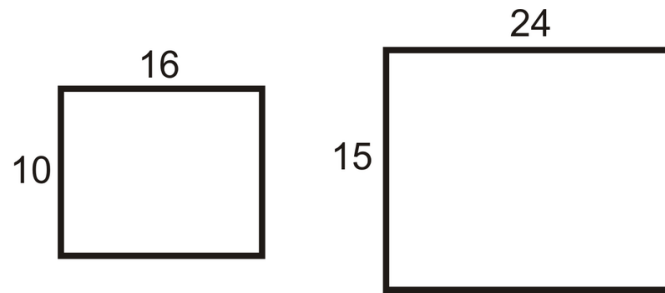

The scale factor is $\frac{16}{24}$, which reduces to $\frac{2}{3}$. The perimeter of the smaller rectangle is 52 units. The perimeter of the larger rectangle is 78 units. The ratio of the perimeters is $\frac{52}{78} = \frac{2}{3}$.

Example B

Find the area of each rectangle from Example A. Then, find the ratio of the areas.

$$A_{small} = 10 \cdot 16 = 160 \text{ units}^2$$

$$A_{large} = 15 \cdot 24 = 360 \text{ units}^2$$

The ratio of the areas would be $\frac{160}{360} = \frac{4}{9}$.

The ratio of the sides, or scale factor was $\frac{2}{3}$ and the ratio of the areas is $\frac{4}{9}$.

Example C

Find the ratio of the areas of the rhombi below. The rhombi are similar.

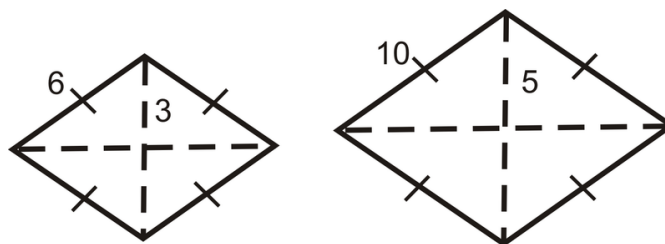

There are two ways to approach this problem. One way would be to use the Pythagorean Theorem to find the length of the 3rd side in the triangle and then apply the area formulas and make a ratio. The second, and easier way, would be to find the ratio of the sides and then square that. $(\frac{3}{5})^2 = \frac{9}{25}$

Watch this video for help with the Examples above.



MEDIA

Click image to the left for more content.

CK-12 Foundation: Chapter10AreaandPerimeterofSimilarPolygonsB

Concept Problem Revisited

You should end up with an $18 \text{ in} \times 18 \text{ in}$ drawing of your handprint.

Vocabulary

Perimeter is the distance around a shape. The perimeter of any figure must have a unit of measurement attached to it. If no specific units are given (feet, inches, centimeters, etc), write “units.” **Area** is the amount of space inside a figure. Area is measured in square units. Polygons are **similar** when their corresponding angles are equal and their corresponding sides are in the same proportion. Similar polygons are the same shape but not necessarily the same size.

Guided Practice

- Two trapezoids are similar. If the scale factor is $\frac{3}{4}$ and the area of the smaller trapezoid is 81 cm^2 , what is the area of the larger trapezoid?
- Two triangles are similar. The ratio of the areas is $\frac{25}{64}$. What is the scale factor?
- Using the ratios from #2, find the length of the base of the smaller triangle if the length of the base of the larger triangle is 24 units.

Answers:

1. First, the ratio of the areas would be $(\frac{3}{4})^2 = \frac{9}{16}$. Now, we need the area of the larger trapezoid. To find this, we would multiply the area of the smaller trapezoid by the scale factor. However, we would need to flip the scale factor over to be $\frac{16}{9}$ because we want the larger area. This means we need to multiply by a scale factor that is larger than one. $A = \frac{16}{9} \cdot 81 = 144 \text{ cm}^2$.

2. The scale factor is $\sqrt{\frac{25}{64}} = \frac{5}{8}$.

3. All you would need to do is multiply the scale factor we found in #2 by 24.

$$b = \frac{5}{8} \cdot 24 = 15 \text{ units}$$

Practice

Determine the ratio of the areas, given the ratio of the sides of a polygon.

- $\frac{3}{5}$
- $\frac{1}{4}$
- $\frac{7}{2}$
- $\frac{6}{11}$

Determine the ratio of the sides of a polygon, given the ratio of the areas.

- $\frac{1}{36}$
- $\frac{4}{81}$

7. $\frac{49}{9}$
8. $\frac{25}{144}$

This is an equilateral triangle made up of 4 congruent equilateral triangles.

9. What is the ratio of the areas of the large triangle to one of the small triangles?

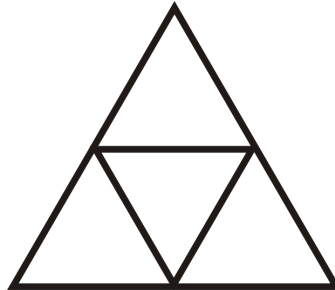

10. What is the scale factor of large to small triangle?
11. If the area of the large triangle is 20 units^2 , what is the area of a small triangle?
12. If the length of the altitude of a small triangle is $2\sqrt{3}$, find the perimeter of the large triangle.
13. Carol drew two equilateral triangles. Each side of one triangle is 2.5 times as long as a side of the other triangle. The perimeter of the smaller triangle is 40 cm. What is the perimeter of the larger triangle?
14. If the area of the smaller triangle is 75 cm^2 , what is the area of the larger triangle from #13?
15. Two rectangles are similar with a scale factor of $\frac{4}{7}$. If the area of the larger rectangle is 294 in^2 , find the area of the smaller rectangle.
16. Two triangles are similar with a scale factor of $\frac{1}{3}$. If the area of the smaller triangle is 22 ft^2 , find the area of the larger triangle.
17. The ratio of the areas of two similar squares is $\frac{16}{81}$. If the length of a side of the smaller square is 24 units, find the length of a side in the larger square.
18. The ratio of the areas of two right triangles is $\frac{2}{3}$. If the length of the hypotenuse of the larger triangle is 48 units, find the length of the smaller triangle's hypotenuse.

Questions 19-22 build off of each other. You may assume the problems are connected.

19. Two similar rhombi have areas of 72 units^2 and 162 units^2 . Find the ratio of the areas.
20. Find the scale factor.
21. The diagonals in these rhombi are congruent. Find the length of the diagonals and the sides.
22. What type of rhombi are these quadrilaterals?
23. The area of one square on a game board is exactly twice the area of another square. Each side of the larger square is 50 mm long. How long is each side of the smaller square?

10.8 Circumference

Here you'll learn how to calculate the circumference of a circle.

What if you wanted to find the "length" of the crust for an entire pizza? A typical large pizza has a diameter of 14 inches and is cut into 8 or 10 pieces. Think of the crust as the circumference of the pizza. Find the circumference. After completing this Concept, you'll be able to solve this problem.



Watch This



MEDIA

Click image to the left for more content.

[CK-12 Foundation: Chapter10CircumferenceA](#)

Learn more aboutcircumference by watching the videoat thislink.

Guidance

Circumference is the distance around a circle. The circumference can also be called the perimeter of a circle. However, we use the term circumference for circles because they are round. The term perimeter is reserved for figures with straight sides. In order to find the formula for the circumference of a circle, we first need to determine the ratio between the circumference and diameter of a circle.

Investigation: Finding π (π)

Tools Needed: paper, pencil, compass, ruler, string, and scissors

1. Draw three circles with radii of 2 in, 3 in, and 4 in. Label the centers of each A , B , and C .
2. Draw in the diameters and determine their lengths. Are all the diameter lengths the same in $\odot A$? $\odot B$? $\odot C$?

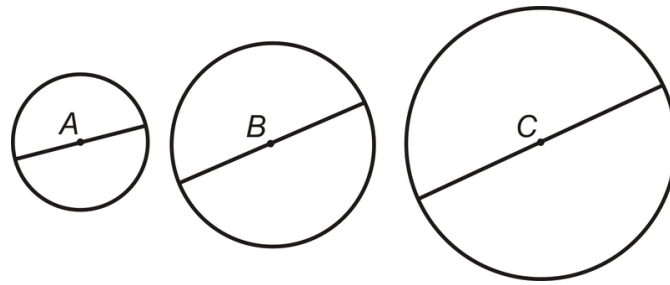

3. Take the string and outline each circle with it. The string represents the circumference of the circle. Cut the string so that it perfectly outlines the circle. Then, lay it out straight and measure, in inches. Round your answer to the nearest $\frac{1}{8}$ -inch. Repeat this for the other two circles.

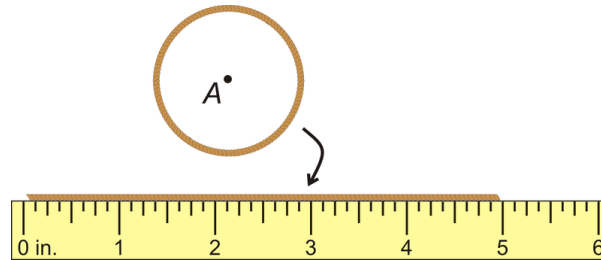

4. Find $\frac{\text{circumference}}{\text{diameter}}$ for each circle. Record your answers to the nearest thousandth. What do you notice?

From this investigation, you should see that $\frac{\text{circumference}}{\text{diameter}}$ approaches 3.14159... The bigger the diameter, the closer the ratio was to this number. We call this number π , the Greek letter “pi.” It is an irrational number because the decimal never repeats itself. Pi has been calculated out to the millionth place and there is still no pattern in the sequence of numbers. When finding the circumference and area of circles, we must use π . π , or “pi” is the ratio of the circumference of a circle to its diameter. It is approximately equal to 3.14159265358979323846... To see more digits of π , go to <http://www.eveandersson.com/pi/digits/>.

From this Investigation, we found that $\frac{\text{circumference}}{\text{diameter}} = \pi$. In other words, $C = \pi d$. We can also say $C = 2\pi r$ because $d = 2r$.

Example A

Find the circumference of a circle with a radius of 7 cm.

Plug the radius into the formula.

$$C = 2\pi(7) = 14\pi \approx 44 \text{ cm}$$

Depending on the directions in a given problem, you can either leave the answer in terms of π or multiply it out and get an approximation. Make sure you read the directions.

Example B

The circumference of a circle is 64π . Find the diameter.

Again, you can plug in what you know into the circumference formula and solve for d .

$$64\pi = \pi d = 14\pi$$

Example C

A circle is inscribed in a square with 10 in. sides. What is the circumference of the circle? Leave your answer in terms of π .

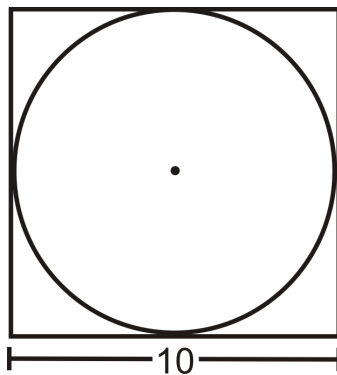

From the picture, we can see that the diameter of the circle is equal to the length of a side. Use the circumference formula.

$$C = 10\pi \text{ in.}$$

Watch this video for help with the Examples above.



MEDIA

Click image to the left for more content.

[CK-12 Foundation: Chapter10CircumferenceB](#)

Concept Problem Revisited

The entire length of the crust, or the circumference of the pizza is $14\pi \approx 44 \text{ in.}$

Vocabulary

A **circle** is the set of all points that are the same distance away from a specific point, called the **center**. A **radius** is the distance from the center to the outer rim of the circle. A **chord** is a line segment whose endpoints are on a circle. A **diameter** is a chord that passes through the center of the circle. The length of a diameter is two times the length of a radius. **Circumference** is the distance around a circle. π , or "**pi**" is the ratio of the circumference of a circle to its diameter.

Guided Practice

1. Find the perimeter of the square. Is it more or less than the circumference of the circle? Why?

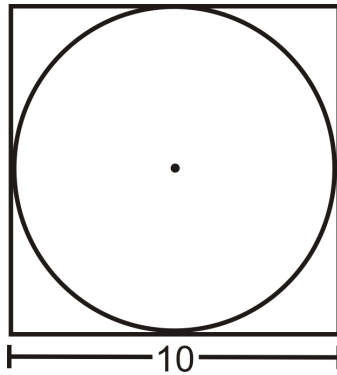

2. The tires on a compact car are 18 inches in diameter. How far does the car travel after the tires turn once? How far does the car travel after 2500 rotations of the tires?



3. Find the radius of circle with circumference 88 in.

Answers:

1. The perimeter is $P = 4(10) = 40$ in. In order to compare the perimeter with the circumference we should change the circumference into a decimal.

$C = 10\pi \approx 31.42$ in. This is less than the perimeter of the square, which makes sense because the circle is smaller than the square.

2. One turn of the tire is the circumference. This would be $C = 18\pi \approx 56.55$ in. 2500 rotations would be $2500 \cdot 56.55 \text{ in} \approx 141,375$ in, 11,781 ft, or 2.23 miles.

3. Use the formula for circumference and solve for the radius.

$$\begin{aligned} C &= 2\pi r \\ 88 &= 2\pi r \\ \frac{44}{\pi} &= r \\ r &\approx 14 \text{ in} \end{aligned}$$

Practice

Fill in the following table. Leave all answers in terms of π .

TABLE 10.1:

| | <i>diameter</i> | <i>radius</i> | <i>circumference</i> |
|----|-----------------|---------------|----------------------|
| 1. | 15 | | |
| 2. | | 4 | |
| 3. | 6 | | |
| 4. | | | 84π |
| 5. | | 9 | |
| 6. | | | 25π |
| 7. | | | 2π |
| 8. | 36 | | |

9. Find the radius of circle with circumference 88 in.
 10. Find the circumference of a circle with $d = \frac{20}{\pi} \text{ cm}$.

Square $PQSR$ is inscribed in $\odot T$. $RS = 8\sqrt{2}$.

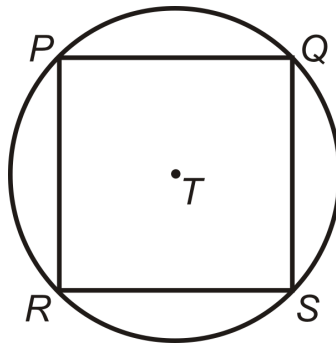

11. Find the length of the diameter of $\odot T$.
 12. How does the diameter relate to $PQSR$?
 13. Find the perimeter of $PQSR$.
 14. Find the circumference of $\odot T$.
15. A truck has tires with a 26 in diameter.
- How far does the truck travel every time a tire turns exactly once?
 - How many times will the tire turn after the truck travels 1 mile? (1 mile = 5280 feet)
16. Jay is decorating a cake for a friend's birthday. They want to put gumdrops around the edge of the cake which has a 12 in diameter. Each gumdrop is has a diameter of 1.25 cm. To the nearest gumdrop, how many will they need?
17. Bob wants to put new weather stripping around a semicircular window above his door. The base of the window (diameter) is 36 inches. How much weather stripping does he need?
18. Each car on a Ferris wheel travels 942.5 ft during the 10 rotations of each ride. How high is each car at the highest point of each rotation?

10.9 Arc Length

Here you'll learn how to find the length of an arc.

What if you wanted to find the "length" of the crust for an individual slice of pizza? A typical large pizza has a diameter of 14 inches and is cut into 8 or 10 pieces. If the "length" of the entire crust is the circumference of the pizza, find the "length" of the crust for one piece of pizza when the entire pizza is cut into a) 8 pieces or b) 10 pieces. After completing this Concept, you'll be able to answer these questions.



Watch This



MEDIA

Click image to the left for more content.

[CK-12 Foundation: Chapter10ArcLengthA](#)

Learn more about arc length by watching the video at this link.

Guidance

One way to measure arcs is in degrees. This is called the "arc measure" or "degree measure." Arcs can also be measured in length, as a portion of the circumference. **Arc length** is the length of an arc or a portion of a circle's circumference. The arc length is directly related to the degree arc measure.

Arc Length Formula: If d is the diameter or r is the radius, the length of $\widehat{AB} = \frac{m\widehat{AB}}{360^\circ} \cdot \pi d$ or $\frac{m\widehat{AB}}{360^\circ} \cdot 2\pi r$.

Example A

Find the length of \widehat{PQ} . Leave your answer in terms of π .

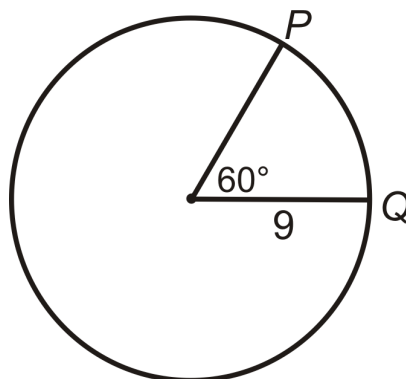

In the picture, the central angle that corresponds with \widehat{PQ} is 60° . This means that $m\widehat{PQ} = 60^\circ$ as well. So, think of the arc length as a portion of the circumference. There are 360° in a circle, so 60° would be $\frac{1}{6}$ of that ($\frac{60^\circ}{360^\circ} = \frac{1}{6}$). Therefore, the length of \widehat{PQ} is $\frac{1}{6}$ of the circumference.

$$\text{length of } \widehat{PQ} = \frac{1}{6} \cdot 2\pi(9) = 3\pi$$

Example B

The arc length of $\widehat{AB} = 6\pi$ and is $\frac{1}{4}$ the circumference. Find the radius of the circle.

If 6π is $\frac{1}{4}$ the circumference, then the total circumference is $4(6\pi) = 24\pi$. To find the radius, plug this into the circumference formula and solve for r .

$$24\pi = 2\pi r$$

$$12 = r$$

Example C

Find the measure of the central angle or \widehat{PQ} .

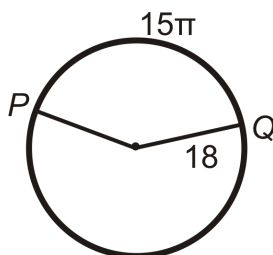

Let's plug in what we know to the Arc Length Formula.

$$15\pi = \frac{m\widehat{PQ}}{360^\circ} \cdot 2\pi(18)$$

$$15 = \frac{m\widehat{PQ}}{10^\circ}$$

$$150^\circ = m\widehat{PQ}$$

Watch this video for help with the Examples above.

MEDIA

Click image to the left for more content.

[CK-12 Foundation: Chapter10ArcLengthB](#)

Concept Problem Revisited

In the picture below, the top piece of pizza is if it is cut into 8 pieces. Therefore, for $\frac{1}{8}$ of the pizza, one piece would have $\frac{44}{8} \approx 5.5$ inches of crust. The bottom piece of pizza is if the pizza is cut into 10 pieces. For $\frac{1}{10}$ of the crust, one piece would have $\frac{44}{10} \approx 4.4$ inches of crust.



Vocabulary

Circumference is the distance around a circle. **Arc length** is the length of an arc or a portion of a circle's circumference.

Guided Practice

Find the arc length of \widehat{PQ} in $\odot A$. Leave your answers in terms of π .

1.

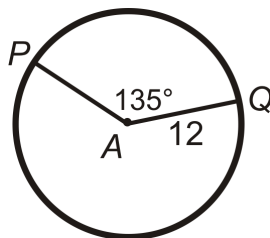

2.

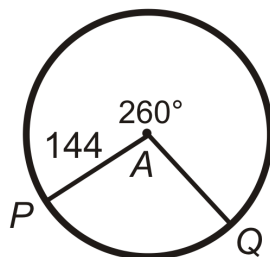

3. An extra large pizza has a diameter of 20 inches and is cut into 12 pieces. Find the length of the crust for one piece of pizza.

**Answers:**

1. Use the Arc Length formula.

$$\widehat{PQ} = \frac{135}{360} \cdot 2\pi(12)$$

$$\widehat{PQ} = \frac{3}{8} \cdot 24\pi$$

$$\widehat{PQ} = 9\pi$$

2. Use the Arc Length formula.

$$\widehat{PQ} = \frac{360 - 260}{360} \cdot 2\pi(144)$$

$$\widehat{PQ} = \frac{5}{18} \cdot 288\pi$$

$$\widehat{PQ} = 80\pi$$

3. The entire length of the crust, or the circumference of the pizza, is $20\pi \approx 62.83$ in. In $\frac{1}{12}$ of the pizza, one piece would have $\frac{62.83}{12} \approx 5.24$ inches of crust.

Practice

Find the arc length of \widehat{PQ} in $\odot A$. Leave your answers in terms of π .

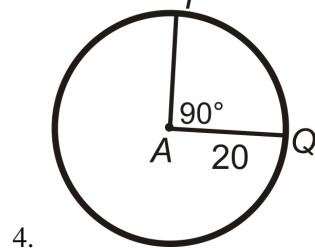
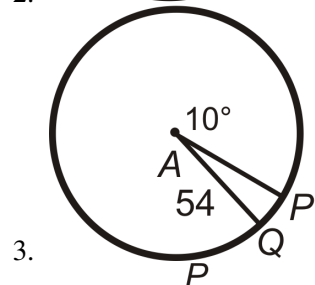
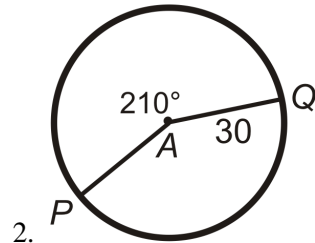
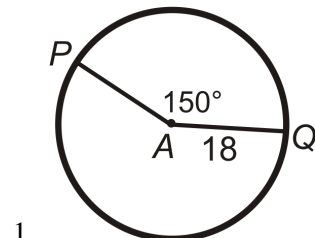

Find PA (the radius) in $\odot A$. Leave your answer in terms of π .

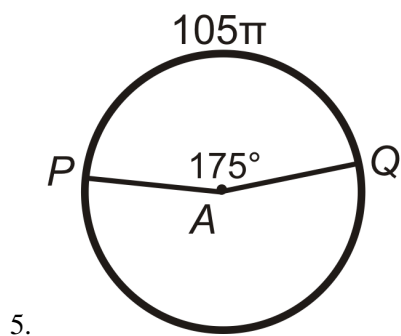

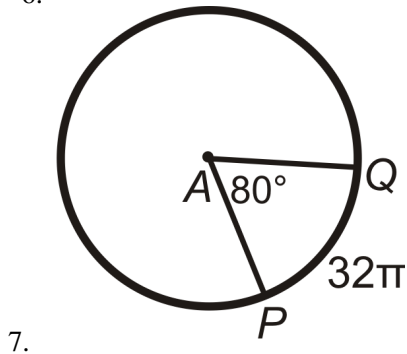
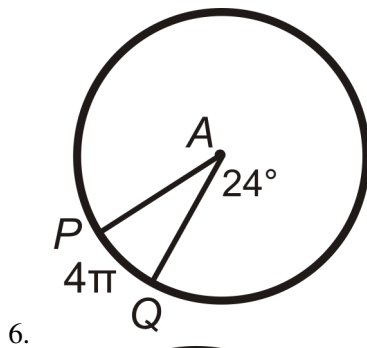

Find the central angle or $m\widehat{PQ}$ in $\odot A$. Round any decimal answers to the nearest tenth.

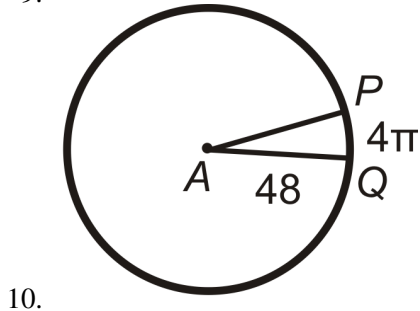
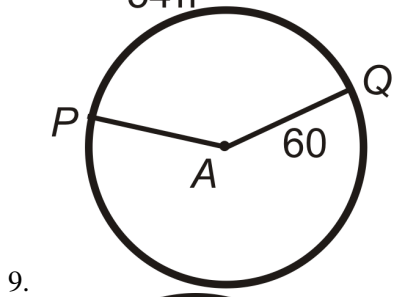
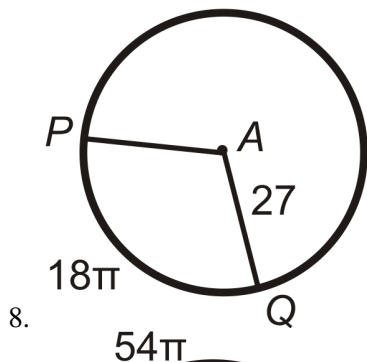

11. The Olympics symbol is five congruent circles arranged as shown below. Assume the top three circles are tangent to each other. Brad is tracing the entire symbol for a poster. How far will his pen point travel?

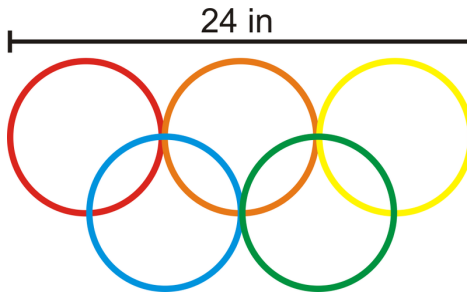

Mario's Pizza Palace offers a stuffed crust pizza in three sizes (diameter length) for the indicated prices:

The Little Cheese, 8 in, \$7.00

The Big Cheese, 10 in, \$9.00

The Cheese Monster, 12 in, \$12.00

12. What is the crust (in) to price (\$) ratio for The Little Cheese?
13. What is the crust (in) to price (\$) ratio for The Little Cheese?
14. What is the crust (in) to price (\$) ratio for The Little Cheese?
15. Michael thinks the cheesy crust is the best part of the pizza and wants to get the most crust for his money. Which pizza should he buy?

10.10 Area of a Circle

Here you'll learn how to calculate the area of a circle.

What if you wanted to figure out the area of a circle with a radius of 5 inches? After completing this Concept, you'll be able to answer questions like this.

Watch This



MEDIA

Click image to the left for more content.

[CK-12 Foundation: Chapter10AreaofaCircleA](#)

Learn more about area of circles by watching the video at this link.

Guidance

Recall that π is the ratio between the circumference of a circle and its diameter. We are going to use the formula for circumference to derive the formula for area.

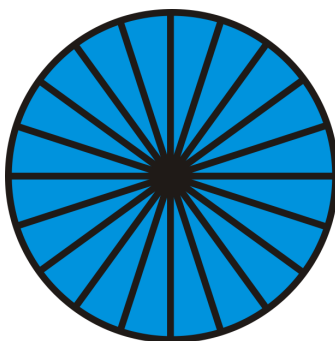

First, take a circle and divide it up into several wedges, or sectors. Then, unfold the wedges so they are all on one line, with the points at the top.

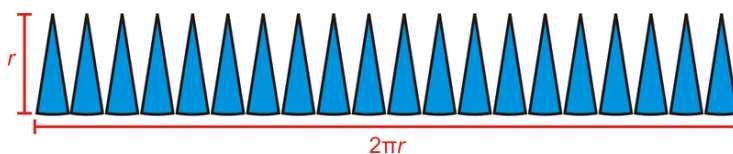

Notice that the height of the wedges is r , the radius, and the length is the circumference of the circle. Now, we need to take half of these wedges and flip them upside-down and place them in the other half so they all fit together.

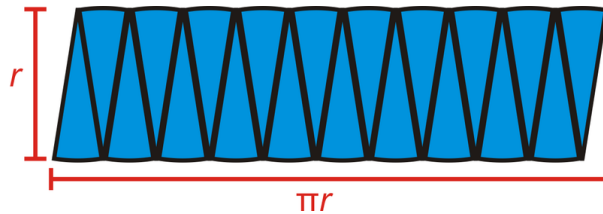

Now our circle looks like a parallelogram. The area of this parallelogram is $A = bh = \pi r \cdot r = \pi r^2$.

To see an animation of this derivation, see <http://www.rkm.com.au/ANIMATIONS/animation-Circle-Area-Derivation.html>, by Russell Knightley.

The formula for the **area of a circle** is $A = \pi r^2$ where r is the radius of the circle.

Example A

Find the area of a circle with a diameter of 12 cm.

If the diameter is 12 cm, then the radius is 6 cm. The area is $A = \pi(6^2) = 36\pi \text{ cm}^2$.

Example B

If the area of a circle is 20π , what is the radius?

Work backwards on this problem. Plug in the area and solve for the radius.

$$\begin{aligned} 20\pi &= \pi r^2 \\ 20 &= r^2 \\ r &= \sqrt{20} = 2\sqrt{5} \end{aligned}$$

Just like the circumference, we will leave our answers in terms of π , unless otherwise specified. In Example 2, the radius could be $\pm 2\sqrt{5}$, however the radius is always positive, so we do not need the negative answer.

Example C

A circle is inscribed in a square. Each side of the square is 10 cm long. What is the area of the circle?

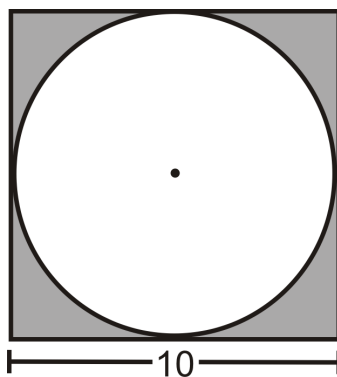

The diameter of the circle is the same as the length of a side of the square. Therefore, the radius is half the length of the side, or 5 cm.

$$A = \pi 5^2 = 25\pi \text{ cm}$$

Watch this video for help with the Examples above.



MEDIA

Click image to the left for more content.

[CK-12 Foundation: Chapter10AreaofaCircleB](#)

Concept Problem Revisited

A circle with a radius of 5 inches has area $\pi 5^2 = 25\pi \text{ in}^2$.

Vocabulary

A **circle** is the set of all points that are the same distance away from a specific point, called the **center**. A **radius** is the distance from the center to the outer rim of the circle. A **chord** is a line segment whose endpoints are on a circle. A **diameter** is a chord that passes through the center of the circle. The length of a diameter is two times the length of a radius. **Area** is the amount of space inside a figure and is measured in square units. π , or “**pi**” is the ratio of the circumference of a circle to its diameter.

Guided Practice

1. Find the area of the shaded region from Example C.
2. Find the diameter of a circle with area 36π .
3. Find the area of a circle with diameter 20 inches.

Answers:

1. The area of the shaded region would be the area of the square minus the area of the circle.

$$A = 10^2 - 25\pi = 100 - 25\pi \approx 21.46 \text{ cm}^2$$

2. First, use the formula for the area of a circle to solve for the radius of the circle.

$$\begin{aligned} A &= \pi r^2 \\ 36\pi &= \pi r^2 \\ 36 &= r^2 \\ r &= 6 \end{aligned}$$

If the radius is 6 units, then the diameter is 12 units.

3. If the diameter is 20 inches that means that the radius is 10 inches. Now we can use the formula for the area of a circle. $A = \pi(10)^2 = 100\pi \text{ in}^2$.

Practice

Fill in the following table. Leave all answers in terms of π .

TABLE 10.2:

| | <i>radius</i> | <i>area</i> | <i>diameter</i> |
|-----|-----------------|-------------|-----------------|
| 1. | 2 | | |
| 2. | | 16π | |
| 3. | | | 10 |
| 4. | | | 24 |
| 5. | 9 | | |
| 6. | | 90π | |
| 7. | | | 35 |
| 8. | $\frac{7}{\pi}$ | | |
| 9. | | | 60 |
| 10. | | 36π | |

Find the area of the shaded region. Round your answer to the nearest hundredth.

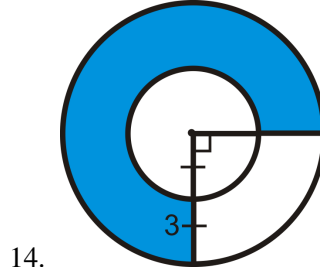
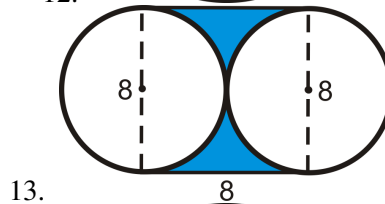
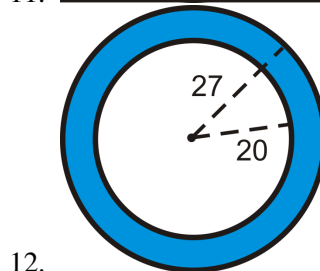
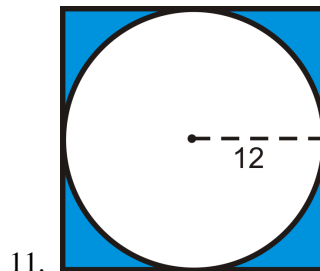

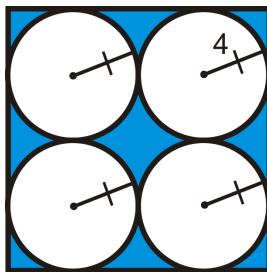

15.

16. Carlos has 400 ft of fencing to completely enclose an area on his farm for an animal pen. He could make the area a square or a circle. If he uses the entire 400 ft of fencing, how much area is contained in the square and the circle? Which shape will yield the greatest area?

10.11 Area of Sectors and Segments

Here you'll learn how to find the area of a sector or a segment of a circle.

What if you wanted to find the area of a pizza, this time taking into consideration the area of the crust? In another Concept, we found the length of the crust for a 14 in pizza. However, crust typically takes up some area on a pizza. Leave your answers in terms of π and reduced improper fractions.



- Find the area of the crust of a deep-dish 16 in pizza. A typical deep-dish pizza has 1 in of crust around the toppings.
 - A thin crust pizza has $\frac{1}{2}$ - in of crust around the edge of the pizza. Find the area of a thin crust 16 in pizza.
 - Which piece of pizza has more crust? A twelfth of the deep dish pizza or a fourth of the thin crust pizza?
- After completing this Concept, you will be able to answer these questions.

Watch This



MEDIA

Click image to the left for more content.

[CK-12 Foundation: Chapter10AreaofSectorsandSegmentsA](#)

[Learn more about the area of a sector by watching the video at this link.](#)

[Watch this video to learn even more about the area of a sector.](#)

Guidance

A **sector of a circle** is the area bounded by two radii and the arc between the endpoints of the radii.



The area of a sector is a fractional part of the area of the circle, just like arc length is a fractional portion of the circumference. The **Area of a sector** is $A = \frac{m\widehat{AB}}{360^\circ} \cdot \pi r^2$ where r is the radius and \widehat{AB} is the arc bounding the sector. Another way to write the sector formula is $A = \frac{\text{central angle}}{360^\circ} \cdot \pi r^2$.

The last part of a circle that we can find the area of is called a segment, not to be confused with a line segment. A **segment of a circle** is the area of a circle that is bounded by a chord and the arc with the same endpoints as the chord. The **area** of a segment is $A_{\text{segment}} = A_{\text{sector}} - A_{\triangle ABC}$

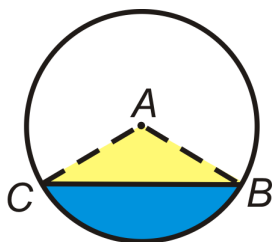

Example A

Find the area of the blue sector. Leave your answer in terms of π .

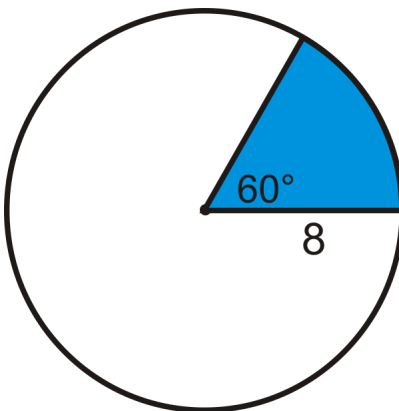

In the picture, the central angle that corresponds with the sector is 60° . 60° would be $\frac{1}{6}$ of 360° , so this sector is $\frac{1}{6}$ of the total area.

$$\text{area of blue sector} = \frac{1}{6} \cdot \pi 8^2 = \frac{32}{3} \pi$$

Example B

Find the area of the blue segment below.

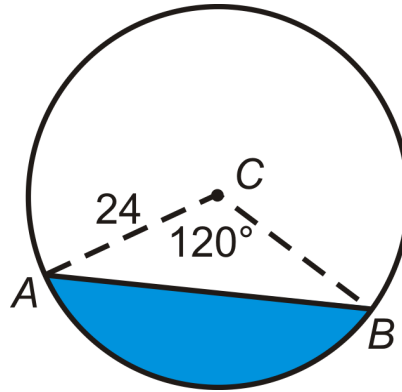

As you can see from the picture, the area of the segment is the area of the sector minus the area of the isosceles triangle made by the radii. If we split the isosceles triangle in half, we see that each half is a 30-60-90 triangle, where the radius is the hypotenuse. Therefore, the height of $\triangle ABC$ is 12 and the base would be $2(12\sqrt{3}) = 24\sqrt{3}$.

$$\begin{aligned} A_{\text{sector}} &= \frac{120}{360}\pi \cdot 24^2 \\ &= 192\pi \end{aligned}$$

$$\begin{aligned} A_{\triangle} &= \frac{1}{2}(24\sqrt{3})(12) \\ &= 144\sqrt{3} \end{aligned}$$

The area of the segment is $A = 192\pi - 144\sqrt{3} \approx 353.8$.

Example C

The area of a sector of circle is 50π and its arc length is 5π . Find the radius of the circle.

First substitute what you know to both the sector formula and the arc length formula. In both equations we will call the central angle, "CA."

$$\begin{aligned} 50\pi &= \frac{CA}{360}\pi r^2 \\ 50 \cdot 360 &= CA \cdot r^2 \\ 18000 &= CA \cdot r^2 \end{aligned}$$

$$\begin{aligned} 5\pi &= \frac{CA}{360}2\pi r \\ 5 \cdot 180 &= CA \cdot r \\ 900 &= CA \cdot r \end{aligned}$$

Now, we can use substitution to solve for either the central angle or the radius. Because the problem is asking for the radius we should solve the second equation for the central angle and substitute that into the first equation for the central angle. Then, we can solve for the radius. Solving the second equation for CA, we have: $CA = \frac{900}{r}$. Plug this into the first equation.

$$\begin{aligned} 18000 &= \frac{900}{r} \cdot r^2 \\ 18000 &= 900r \\ r &= 20 \end{aligned}$$

Watch this video for help with the Examples above.



MEDIA

Click image to the left for more content.

CK-12 Foundation: Chapter10AreaofSectorsandSegmentsB

Concept Problem Revisited

The area of the crust for a deep-dish pizza is $8^2\pi - 7^2\pi = 15\pi$. The area of the crust of the thin crust pizza is $8^2\pi - 7.5^2\pi = \frac{31}{4}\pi$. One-twelfth of the deep dish pizza has $\frac{15}{12}\pi$ or $\frac{5}{4}\pi \text{ in}^2$ of crust. One-fourth of the thin crust pizza has $\frac{31}{16}\pi \text{ in}^2$. To compare the two measurements, it might be easier to put them both into decimals. $\frac{5}{4}\pi \approx 3.93 \text{ in}^2$ and $\frac{31}{16}\pi \approx 6.09 \text{ in}^2$. From this, we see that one-fourth of the thin-crust pizza has more crust than one-twelfth of the deep dish pizza.

Vocabulary

A **circle** is the set of all points that are the same distance away from a specific point, called the **center**. A **radius** is the distance from the center to the outer rim of the circle. A **chord** is a line segment whose endpoints are on a circle. A **diameter** is a chord that passes through the center of the circle. The length of a diameter is two times the length of a radius. **Area** is the amount of space inside a figure and is measured in square units. π , or “**pi**” is the ratio of the circumference of a circle to its diameter. A **sector of a circle** is the area bounded by two radii and the arc between the endpoints of the radii. A **segment of a circle** is the area of a circle that is bounded by a chord and the arc with the same endpoints as the chord.

Guided Practice

- The area of a sector is 135π and the arc measure is 216° . What is the radius of the circle?

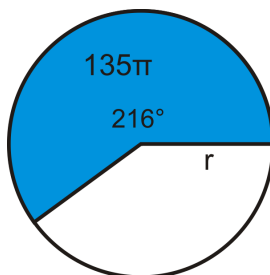

- Find the area of the shaded region. The quadrilateral is a square.

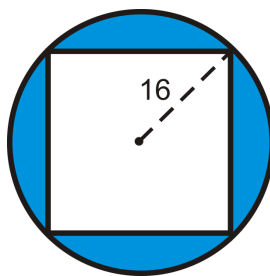

3. Find the area of the blue sector of $\odot A$.

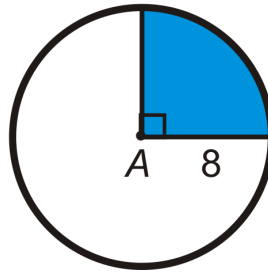

Answers:

1. Plug in what you know to the sector area formula and solve for r .

$$\begin{aligned} 135\pi &= \frac{216^\circ}{360^\circ} \cdot \pi r^2 \\ 135 &= \frac{3}{5} \cdot r^2 \\ \frac{5}{3} \cdot 135 &= r^2 \\ 225 &= r^2 \rightarrow r = \sqrt{225} = 15 \end{aligned}$$

2. The radius of the circle is 16, which is also half of the diagonal of the square. So, the diagonal is 32 and the sides would be $\frac{32}{\sqrt{2}} \cdot \frac{\sqrt{2}}{\sqrt{2}} = 16\sqrt{2}$ because each half of a square is a 45-45-90 triangle.

$$\begin{aligned} A_{\text{circle}} &= 16^2\pi = 256\pi \\ A_{\text{square}} &= (16\sqrt{2})^2 = 256 \cdot 2 = 512 \end{aligned}$$

The area of the shaded region is $256\pi - 512 \approx 292.25$

3. The right angle tells us that this sector represents $\frac{1}{4}$ of the circle. The area of the whole circle is $A = \pi r^2 = 64\pi$. So, the area of the sector is $\frac{1}{4}64\pi = 16\pi$.

Practice

Find the area of the blue sector or segment in $\odot A$. Leave your answers in terms of π . You may use decimals or fractions in your answers, but do not round.

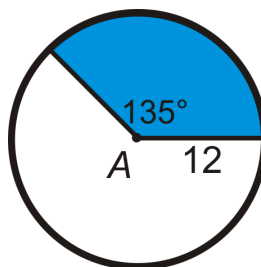

1.

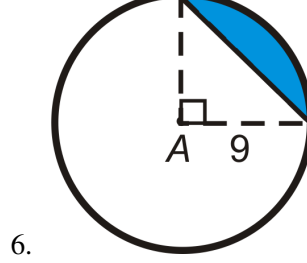
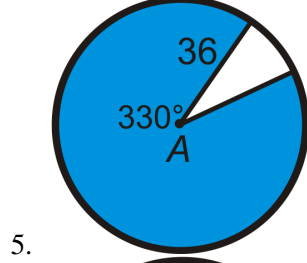
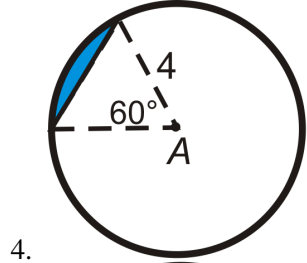
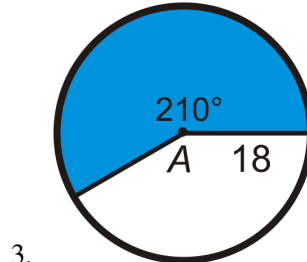
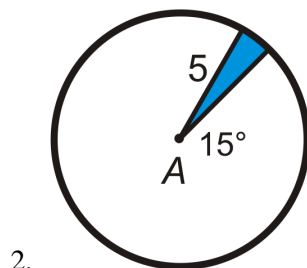

Find the radius of the circle. Leave your answer in simplest radical form.

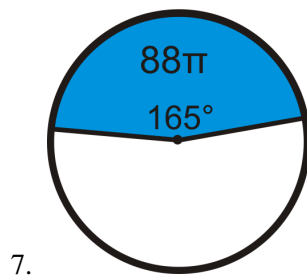

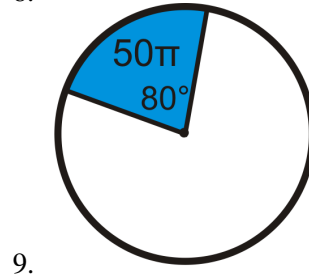
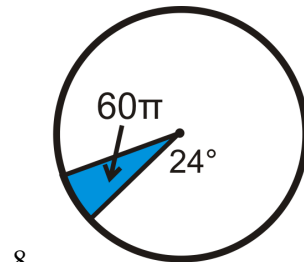

Find the central angle of each blue sector. Round any decimal answers to the nearest tenth.

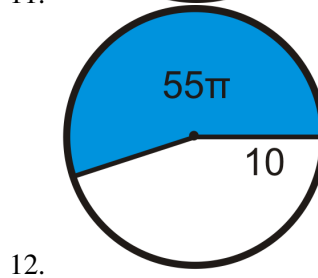
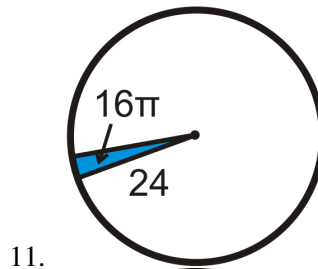
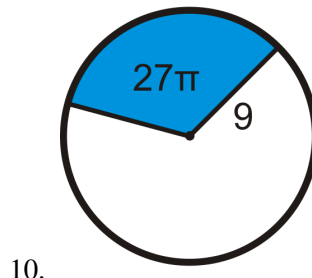

13. The area of a sector of a circle is 54π and its arc length is 6π . Find the radius of the circle.
14. Find the central angle of the sector from #13.
15. The area of a sector of a circle is 2304π and its arc length is 32π . Find the central angle of the sector.

10.12 Area of Regular Polygons

Here you'll learn how to calculate the area and perimeter of a regular polygon.

What if you were asked to find the distance across The Pentagon in Arlington, VA? The Pentagon, which also houses the Department of Defense, is composed of two regular pentagons with the same center. The entire area of the building is 29 acres (40,000 square feet in an acre), with an additional 5 acre courtyard in the center. The length of each outer wall is 921 feet. What is the total distance across the pentagon? Round your answer to the nearest hundredth. After completing this Concept, you'll be able to answer questions like this.



Watch This



MEDIA

Click image to the left for more content.

[CK-12 Foundation: Chapter10AreaofRegularPolygonsA](#)

Learn more about the area of regular polygons by watching the video at this link.

Guidance

A regular polygon is a polygon with congruent sides and angles. Recall that the perimeter of a square is 4 times the length of a side because each side is congruent. We can extend this concept to any regular polygon.

Perimeter of a Regular Polygon: If the length of a side is s and there are n sides in a regular polygon, then the perimeter is $P = ns$.

In order to find the area of a regular polygon, we need to define some new terminology. First, all regular polygons can be inscribed in a circle. So, regular polygons have a **center** and **radius**, which are the center and radius of the circumscribed circle. Also like a circle, a regular polygon will have a central angle formed. In a regular polygon, however, the central angle is the angle formed by two radii drawn to consecutive vertices of the polygon. In the picture below, the central angle is $\angle BAD$. Also, notice that $\triangle BAD$ is an isosceles triangle. Every regular polygon with n sides is formed by n isosceles triangles. The height of these isosceles triangles is called the **apothem**.

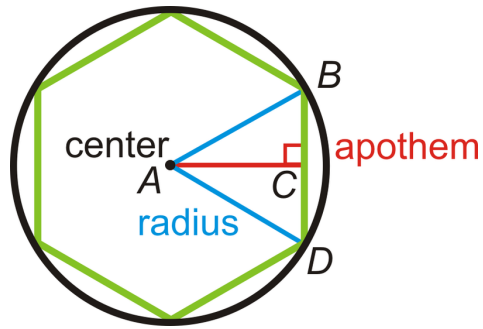

The area of each triangle is $A_{\triangle} = \frac{1}{2}bh = \frac{1}{2}sa$, where s is the length of a side and a is the apothem. If there are n sides in the regular polygon, then it is made up of n congruent triangles.

Area of a Regular Polygon: If there are n sides with length s in a regular polygon and a is the apothem, then $A = \frac{1}{2}asn$ or $A = \frac{1}{2}aP$, where P is the perimeter.

Example A

What is the perimeter of a regular octagon with 4 inch sides?

If each side is 4 inches and there are 8 sides, that means the perimeter is $8(4 \text{ in}) = 32$ inches.

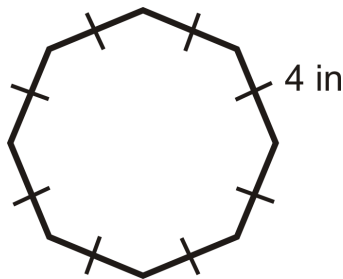

Example B

The perimeter of a regular heptagon is 35 cm. What is the length of each side?

If $P = ns$, then $35 \text{ cm} = 7s$. Therefore, $s = 5 \text{ cm}$.

Example C

Find the length of the apothem in the regular octagon. Round your answer to the nearest hundredth.

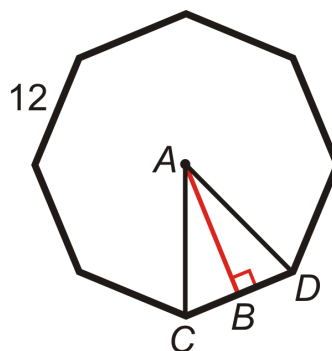

To find the length of the apothem, AB , you will need to use the trig ratios. First, find $m\angle CAD$. There are 360° around a point, so $m\angle CAD = \frac{360^\circ}{8} = 45^\circ$. Now, we can use this to find the other two angles in $\triangle CAD$. $m\angle ACB$ and $m\angle ADC$ are equal because $\triangle CAD$ is a right triangle.

$$\begin{aligned} m\angle CAD + m\angle ACB + m\angle ADC &= 180^\circ \\ 45^\circ + 2m\angle ACB &= 180^\circ \\ 2m\angle ACB &= 135^\circ \\ m\angle ACB &= 67.5^\circ \end{aligned}$$

To find AB , we must use the tangent ratio. You can use either acute angle.

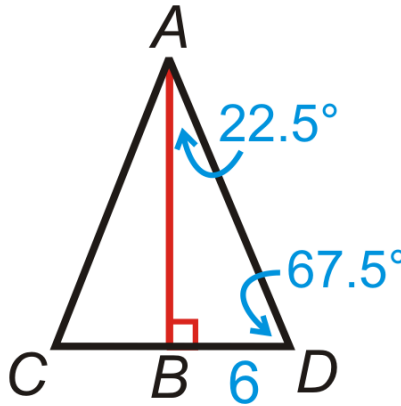

$$\begin{aligned} \tan 67.5^\circ &= \frac{AB}{6} \\ AB &= 6 \cdot \tan 67.5^\circ \approx 14.49 \end{aligned}$$

Watch this video for help with the Examples above.



MEDIA

Click image to the left for more content.

[CK-12 Foundation: Chapter10AreaofRegularPolygonsB](#)

Concept Problem Revisited

From the picture below, we can see that the total distance across the Pentagon is the length of the apothem plus the length of the radius. If the total area of the Pentagon is 34 acres, that is 2,720,000 square feet. Therefore, the area equation is $2720000 = \frac{1}{2}a(921)(5)$ and the apothem is 590.66 ft. To find the radius, we can either use the Pythagorean Theorem, with the apothem and half the length of a side or the sine ratio. Recall from Example 5, that each central angle in a pentagon is 72° , so we would use half of that for the right triangle.

$$\sin 36^\circ = \frac{460.5}{r} \rightarrow r = \frac{460.5}{\sin 36^\circ} \approx 783.45 \text{ ft.}$$

Therefore, the total distance across is $590.66 + 783.45 = 1374.11$ ft.

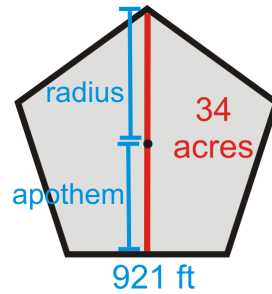

Vocabulary

Perimeter is the distance around a shape. The perimeter of any figure must have a unit of measurement attached to it. If no specific units are given (feet, inches, centimeters, etc), write "units." **Area** is the amount of space inside a figure. Area is measured in square units. The **center** and **radius** of a regular polygon is the center and radius of the circumscribed circle. An **apothem** is a line segment drawn from the center of a regular polygon to the midpoint of one of its sides.

Guided Practice

- Find the area of the regular octagon in Example C.

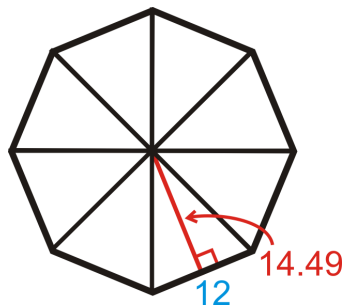

- Find the area of the regular polygon with radius 4.

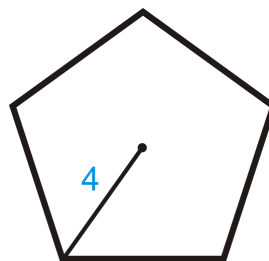

- The area of a regular hexagon is $54\sqrt{3}$ and the perimeter is 36. Find the length of the sides and the apothem.

Answers:

- The octagon can be split into 8 congruent triangles. So, if we find the area of one triangle and multiply it by 8, we will have the area of the entire octagon.

$$A_{\text{octagon}} = 8 \left(\frac{1}{2} \cdot 12 \cdot 14.49 \right) = 695.52 \text{ units}^2$$

2. In this problem we need to find the apothem and the length of the side before we can find the area of the entire polygon. Each central angle for a regular pentagon is $\frac{360^\circ}{5} = 72^\circ$. So, half of that, to make a right triangle with the apothem, is 36° . We need to use sine and cosine.

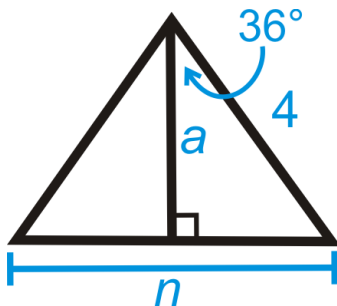

$$\begin{aligned} \sin 36^\circ &= \frac{.5n}{4} & \cos 36^\circ &= \frac{a}{4} \\ 4 \sin 36^\circ &= \frac{1}{2}n & 4 \cos 36^\circ &= a \\ 8 \sin 36^\circ &= n & a &\approx 3.24 \\ n &\approx 4.7 \end{aligned}$$

Using these two pieces of information, we can now find the area. $A = \frac{1}{2}(3.24)(5)(4.7) \approx 38.07 \text{ units}^2$.

3. Plug in what you know into both the area and the perimeter formulas to solve for the length of a side and the apothem.

$$\begin{aligned} P &= sn & A &= \frac{1}{2}aP \\ 36 &= 6s & 54\sqrt{3} &= \frac{1}{2}a(36) \\ s &= 6 & 54\sqrt{3} &= 18a \\ & & 3\sqrt{3} &= a \end{aligned}$$

Practice

Use the regular hexagon below to answer the following questions. Each side is 10 cm long.

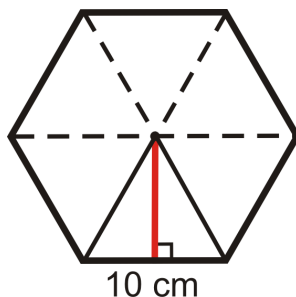

- Each dashed line segment is $a(n)$ _____.
- The red line segment is $a(n)$ _____.
- There are _____ congruent triangles in a regular hexagon.
- In a regular hexagon, all the triangles are _____.
- Find the radius of this hexagon.
- Find the apothem.
- Find the perimeter.
- Find the area.

Find the area and perimeter of each of the following regular polygons. Round your answer to the nearest hundredth.

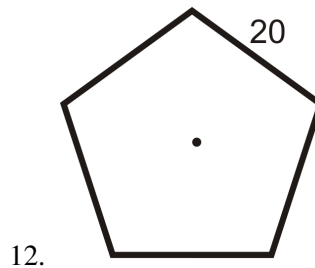
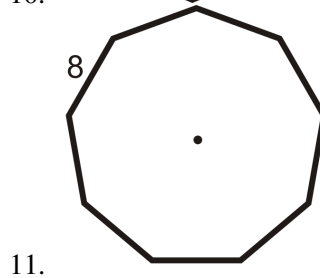
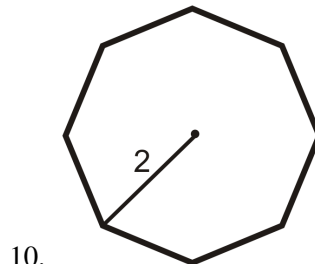
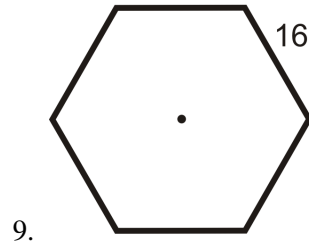

- If the perimeter of a regular decagon is 65, what is the length of each side?
- A regular polygon has a perimeter of 132 and the sides are 11 units long. How many sides does the polygon have?
- The area of a regular pentagon is 440.44 in^2 and the perimeter is 80 in. Find the length of the apothem of the pentagon.
- The area of a regular octagon is 695.3 cm^2 and the sides are 12 cm. What is the length of the apothem?

A regular 20-gon and a regular 40-gon are inscribed in a circle with a radius of 15 units.

- Challenge** Derive a formula for the area of a regular hexagon with sides of length s . Your only variable will be s . HINT: Use 30-60-90 triangle ratios.

18. **Challenge** in the following steps you will derive an alternate formula for finding the area of a regular polygon with n sides.

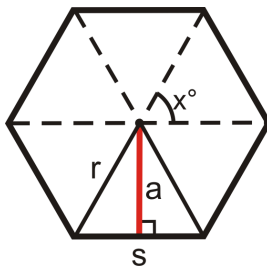

We are going to start by thinking of a polygon with n sides as n congruent isosceles triangles. We will find the sum of the areas of these triangles using trigonometry. First, the area of a triangle is $\frac{1}{2}bh$. In the diagram to the right, this area formula would be $\frac{1}{2}sa$, where s is the length of a side and a is the length of the apothem. In the diagram, x represents the measure of the vertex angle of each isosceles triangle.

- The apothem, a , divides the triangle into two congruent right triangles. The top angle in each is $\frac{x^\circ}{2}$. Find $\sin\left(\frac{x^\circ}{2}\right)$ and $\cos\left(\frac{x^\circ}{2}\right)$.
- Solve your sin equation to find an expression for s in terms of r and x .
- Solve your cos equation to find an expression for a in terms of r and x .
- Substitute these expressions into the equation for the area of one of the triangles, $\frac{1}{2}sa$.
- Since there will be n triangles in an n -gon, you need to multiply your expression from part d by n to get the total area.
- How would you tell someone to find the value of x for a regular n -gon?

Use the formula you derived in problem 18 to find the area of the regular polygons described in problems 19-22. Round your answers to the nearest hundredth.

- Decagon with radius 12 cm.
- 20-gon with radius 5 in.
- 15-gon with radius length 8 cm.
- 45-gon with radius length 7 in.

Summary

This chapter covers perimeter and area of all the basic geometric figures. Perimeter and area are compared and calculated for rectangles, parallelograms, triangles, and then for composite shapes of those figures. The chapter then branches into perimeter and area for other special geometric figures, namely trapezoids, rhombuses, and kites, as well as similar polygons. The chapter wraps up with the circumference of circles and arc length followed by the area of a circle and the area of sectors and segments.

Chapter Keywords

- Perimeter
- Area of a Rectangle: $A = bh$
- Perimeter of a Rectangle $P = 2b + 2h$
- Perimeter of a Square: $P = 4s$
- Area of a Square: $A = s^2$
- Congruent Areas Postulate
- Area Addition Postulate

- Area of a Parallelogram: $A = bh$.
- Area of a Triangle: $A = \frac{1}{2}bh$ or $A = \frac{bh}{2}$
- Area of a Trapezoid: $A = \frac{1}{2}h(b_1 + b_2)$
- Area of a Rhombus: $A = \frac{1}{2}d_1d_2$
- Area of a Kite: $A = \frac{1}{2}d_1d_2$
- Area of Similar Polygons Theorem
- π
- Circumference: $C = \pi d$ or $C = 2\pi r$
- Arc Length
- Arc Length Formula: length of $\widehat{AB} = \frac{m\widehat{AB}}{360^\circ} \cdot \pi d$ or $\frac{m\widehat{AB}}{360^\circ} \cdot 2\pi r$
- Area of a Circle: $A = \pi r^2$
- Sector of a Circle
- Area of a Sector: $A = \frac{m\widehat{AB}}{360^\circ} \cdot \pi r^2$
- Segment of a Circle
- Perimeter of a Regular Polygon: $P = ns$
- Apothem
- Area of a Regular Polygon: $A = \frac{1}{2}asn$ or $A = \frac{1}{2}aP$

Chapter Review

Find the area and perimeter of the following figures. Round your answers to the nearest hundredth.

1. square

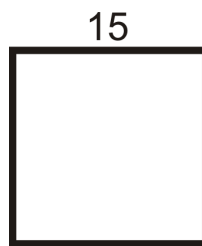

2. rectangle

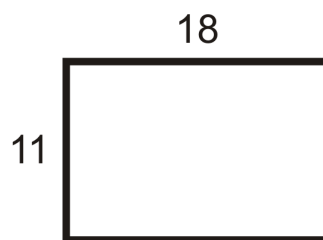

3. rhombus

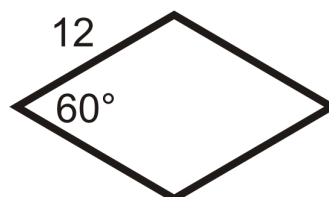

4. regular pentagon

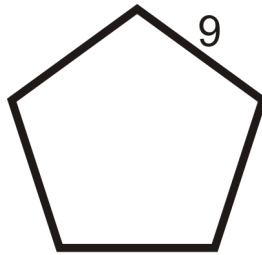

5. parallelogram

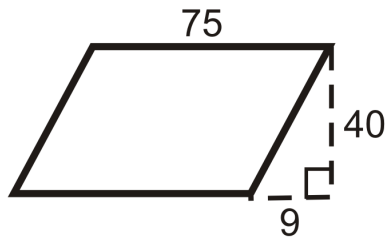

6. regular dodecagon

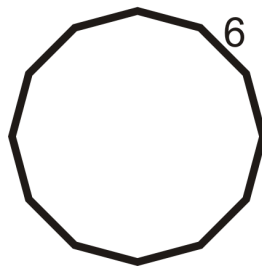

Find the area of the following figures. Leave your answers in simplest radical form.

7. triangle

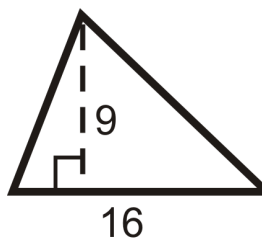

8. kite

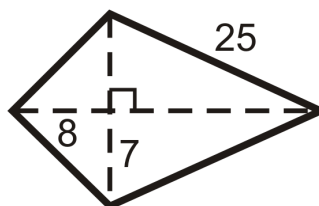

9. isosceles trapezoid

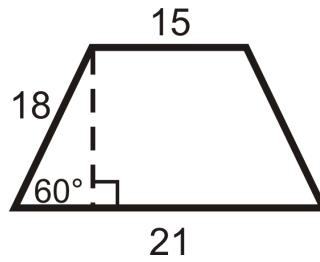

10. Find the area and circumference of a circle with radius 17.
11. Find the area and circumference of a circle with diameter 30.
12. Two similar rectangles have a scale factor $\frac{4}{3}$. If the area of the larger rectangle is 96 units^2 , find the area of the smaller rectangle.

Find the area of the following figures. Round your answers to the nearest hundredth.

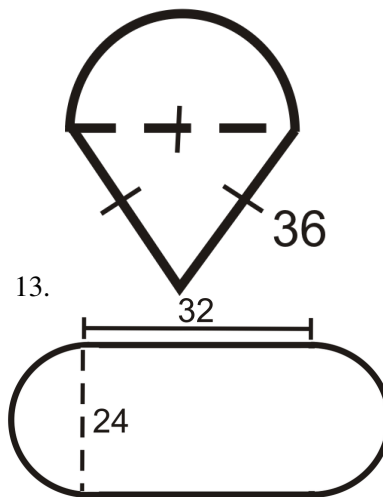

14.

15. find the shaded area (figure is a rhombus)

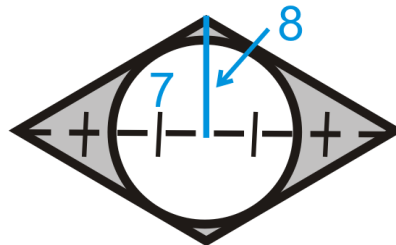

Texas Instruments Resources

In the CK-12 Texas Instruments Geometry FlexBook, there are graphing calculator activities designed to supplement the objectives for some of the lessons in this chapter. See <http://www.ck12.org/flexr/chapter/9695>.

CHAPTER **11** Surface Area and Volume

Chapter Outline

- 11.1 POLYHEDRONS**
 - 11.2 CROSS-SECTIONS AND NETS**
 - 11.3 PRISMS**
 - 11.4 CYLINDERS**
 - 11.5 PYRAMIDS**
 - 11.6 CONES**
 - 11.7 SPHERES**
 - 11.8 COMPOSITE SOLIDS**
 - 11.9 AREA AND VOLUME OF SIMILAR SOLIDS**
-

Introduction

In this chapter we extend what we know about two-dimensional figures to three-dimensional shapes. First, we will determine the parts and different types of 3D shapes. Then, we will find the surface area and volume of prisms, cylinders, pyramids, cones, and spheres. Lastly, we will expand what we know about similar shapes and their areas to similar solids and their volumes.

11.1 Polyhedrons

Here you'll learn how to identify polyhedron and regular polyhedron and the connections between the numbers of faces, edges, and vertices in polyhedron.

What if you were given a solid three-dimensional figure, like a carton of ice cream? How could you determine how the faces, vertices, and edges of that figure are related? After completing this Concept, you'll be able to use Euler's Theorem to answer that question.

Watch This



MEDIA

Click image to the left for more content.

[CK-12 Foundation: Chapter 11 Polyhedrons A](#)

Learn more about 3-D Solid Properties by watching the video at this link.

Guidance

A **polyhedron** is a 3-dimensional figure that is formed by polygons that enclose a region in space. Each polygon in a polyhedron is called a **face**. The line segment where two faces intersect is called an **edge** and the point of intersection of two edges is a **vertex**. There are no gaps between the edges or vertices in a polyhedron. Examples of polyhedrons include a cube, prism, or pyramid. Non-polyhedrons are cones, spheres, and cylinders because they have sides that are not polygons.

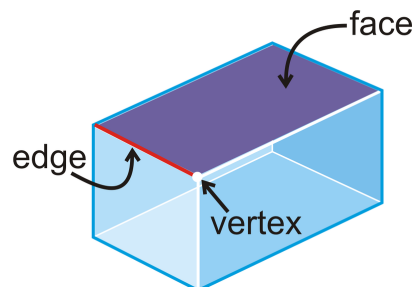

A **prism** is a polyhedron with two congruent bases, in parallel planes, and the lateral sides are rectangles. Prisms are explored in further detail in another Concept.

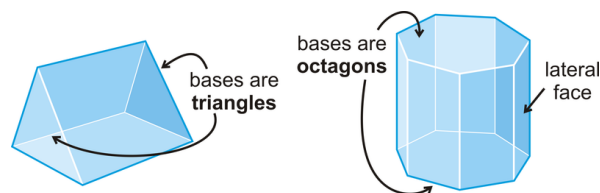

A **pyramid** is a polyhedron with one base and all the lateral sides meet at a common vertex. The lateral sides are triangles. Pyramids are explored in further detail in another Concept.

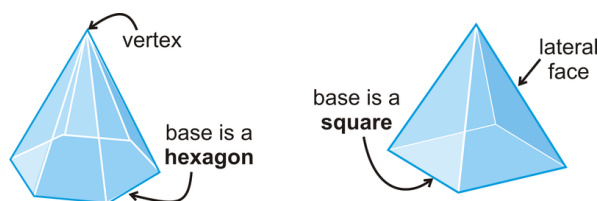

All prisms and pyramids are named by their bases. So, the first prism would be a triangular prism and the second would be an octagonal prism. The first pyramid would be a hexagonal pyramid and the second would be a square pyramid. The lateral faces of a pyramid are always triangles.

Euler's Theorem states that the number of faces (F), vertices (V), and edges (E) of a polyhedron can be related such that $F + V = E + 2$.

A **regular polyhedron** is a polyhedron where all the faces are congruent regular polygons. There are five regular polyhedra called the Platonic solids, after the Greek philosopher Plato. These five solids are significant because they are the only five regular polyhedra. There are only five because the sum of the measures of the angles that meet at each vertex must be less than 360° . Therefore the only combinations are 3, 4 or 5 triangles at each vertex, 3 squares at each vertex or 3 pentagons. Each of these polyhedra have a name based on the number of sides, except the cube.

- **Regular Tetrahedron:** A 4-faced polyhedron where all the faces are equilateral triangles.
- **Cube:** A 6-faced polyhedron where all the faces are squares.
- **Regular Octahedron:** An 8-faced polyhedron where all the faces are equilateral triangles.
- **Regular Dodecahedron:** A 12-faced polyhedron where all the faces are regular pentagons.
- **Regular Icosahedron:** A 20-faced polyhedron where all the faces are equilateral triangles.

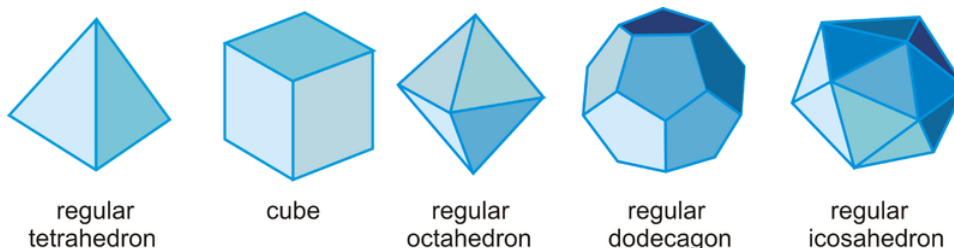

Example A

Determine if the following solids are polyhedrons. If the solid is a polyhedron, name it and determine the number of faces, edges and vertices each has.

a)

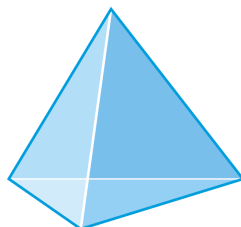

b)

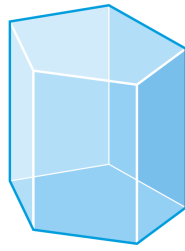

c)

**Solutions:**

- a) The base is a triangle and all the sides are triangles, so this is a polyhedron, a triangular pyramid. There are 4 faces, 6 edges and 4 vertices.
- b) This solid is also a polyhedron because all the faces are polygons. The bases are both pentagons, so it is a pentagonal prism. There are 7 faces, 15 edges, and 10 vertices.
- c) This is a cylinder and has bases that are circles. Circles are not polygons, so it is not a polyhedron.

Example B

Find the number of faces, vertices, and edges in the octagonal prism.

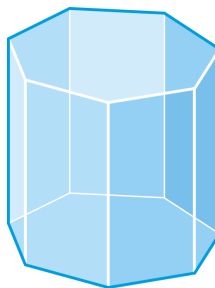

Because this is a polyhedron, we can use Euler's Theorem to find either the number of faces, vertices or edges. It is easiest to count the faces, there are 10 faces. If we count the vertices, there are 16. Using this, we can solve for E in Euler's Theorem.

$$\begin{aligned}
 F + V &= E + 2 \\
 10 + 16 &= E + 2 \\
 24 &= E \quad \text{There are 24 edges.}
 \end{aligned}$$

Example C

In a six-faced polyhedron, there are 10 edges. How many vertices does the polyhedron have?

Solve for V in Euler's Theorem.

$$F + V = E + 2$$

$$6 + V = 10 + 2$$

$$V = 6 \quad \text{There are 6 vertices.}$$

Watch this video for help with the Examples above.

**MEDIA**

Click image to the left for more content.

[CK-12 Foundation: Chapter 11 Polyhedrons B](#)

Vocabulary

A **polyhedron** is a 3-dimensional figure that is formed by polygons that enclose a region in space. Each polygon in a polyhedron is a **face**. The line segment where two faces intersect is an **edge**. The point of intersection of two edges is a **vertex**. A **regular polyhedron** is a polyhedron where all the faces are congruent regular polygons.

Guided Practice

1. In a six-faced polyhedron, there are 10 edges. How many vertices does the polyhedron have?
2. Markus counts the edges, faces, and vertices of a polyhedron. He comes up with 10 vertices, 5 faces, and 12 edges. Did he make a mistake?
3. Is this a polyhedron? Explain.

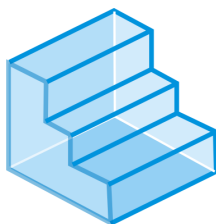
**Answers:**

1. Solve for V in Euler's Theorem.

$$F + V = E + 2$$

$$6 + V = 10 + 2$$

$$V = 6$$

Therefore, there are 6 vertices.

2. Plug all three numbers into Euler's Theorem.

$$F + V = E + 2$$

$$5 + 10 = 12 + 2$$

$$15 \neq 14$$

Because the two sides are not equal, Markus made a mistake.

3. All of the faces are polygons, so this is a polyhedron. Notice that even though not all of the faces are regular polygons, the number of faces, vertices, and edges still works with Euler's Theorem.

Practice

Complete the table using Euler's Theorem.

TABLE 11.1:

| | <i>Name</i> | <i>Faces</i> | <i>Edges</i> | <i>Vertices</i> |
|----|---------------------|--------------|--------------|-----------------|
| 1. | Rectangular Prism | 6 | 12 | |
| 2. | Octagonal Pyramid | | 16 | 9 |
| 3. | Regular Icosahedron | 20 | | 12 |
| 4. | Cube | | 12 | 8 |
| 5. | Triangular Pyramid | 4 | | 4 |
| 6. | Octahedron | 8 | 12 | |
| 7. | Heptagonal Prism | | 21 | 14 |
| 8. | Triangular Prism | 5 | 9 | |

Determine if the following figures are polyhedra. If so, name the figure and find the number of faces, edges, and vertices.

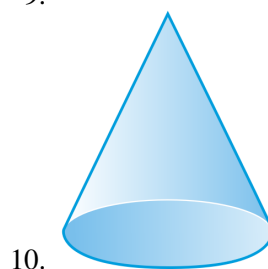
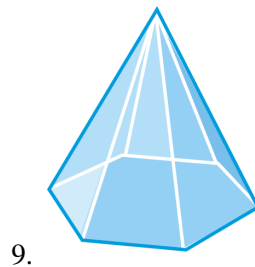

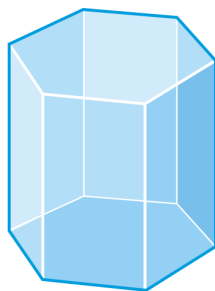

11.



12.



13.

14. A truncated icosahedron is a polyhedron with 12 regular pentagonal faces and 20 regular hexagonal faces and 90 edges. This icosahedron closely resembles a soccer ball. How many vertices does it have? Explain your reasoning.



For problems 15-17, we are going to connect the Platonic Solids to probability. A six sided die is the shape of a cube. The probability of any one side landing face up is $\frac{1}{6}$ because each of the six faces is congruent to each other.

15. What shape would we make a die with 12 faces? If we number these faces 1 to 12, and each face has the same likelihood of landing face up, what is the probability of rolling a multiple of three?
16. I have a die that is a regular octahedron. Each face is labeled with a consecutive prime number starting with 2. What is the largest prime number on my die?
17. **Challenge** Rebecca wants to design a new die. She wants it to have one red face. The other faces will be yellow, blue or green. How many faces should her die have and how many of each color does it need so that: the probability of rolling yellow is eight times the probability of rolling red, the probability of rolling green is half the probability of rolling yellow and the probability of rolling blue is seven times the probability of rolling red?

11.2 Cross-Sections and Nets

Here you'll learn how to view three-dimensional figures in a two-dimensional plane using cross-sections and nets.

What if you wanted to expand your thinking of geometric shapes beyond the flat two-dimensional ones to three dimensional (3D) ones? In this chapter we are going to expand to 3D. Copy the equilateral triangle to the right onto a piece of paper and cut it out. Fold on the dotted lines. What shape do these four equilateral triangles make? If we place two of these equilateral triangles next to each other (like in the far right) what shape do these 8 equilateral triangles make? After completing this Concept, you'll be able to answer questions like these.

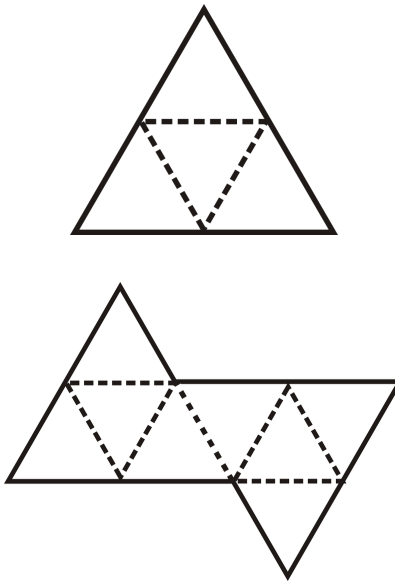

Watch This



MEDIA

Click image to the left for more content.

CK-12 Foundation: Chapter 11 Cross Sections and Nets A

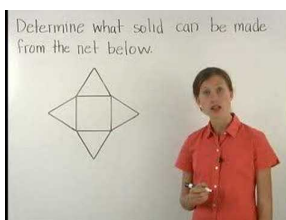

MEDIA

Click image to the left for more content.

Guidance

While our world is three dimensional, we are used to modeling and thinking about three dimensional objects on paper (in two dimensions). There are a few common ways to help think about three dimensions in two dimensions. One way to “view” a three-dimensional figure in a two-dimensional plane, like this text, is to use cross-sections. A **cross-section** is the intersection of a plane with a solid. Another way to represent a three-dimensional figure in a two dimensional plane is to use a net. A **net** is an unfolded, flat representation of the sides of a three-dimensional shape.

Example A

What kind of figure does this net create?

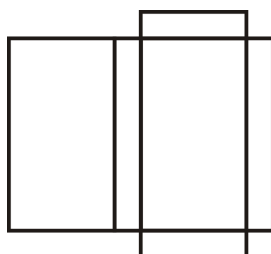

The net creates a rectangular prism.

Example B

Draw a net of the right triangular prism below.

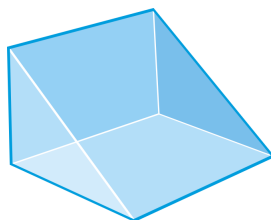

This net will have two triangles and three rectangles. The rectangles are all different sizes and the two triangles are congruent.

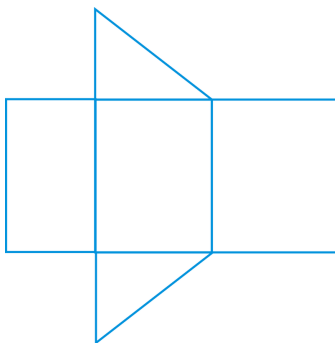

Notice that there could be a couple different interpretations of this, or any, net. For example, this net could have the triangles anywhere along the top or bottom of the three rectangles. Most prisms have multiple nets.

Example C

Describe the cross section formed by the intersection of the plane and the solid.

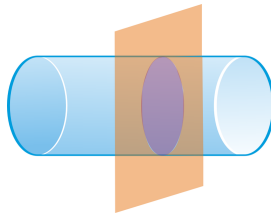

The cross-section is a circle.

Watch this video for help with the Examples above.



MEDIA

Click image to the left for more content.

[CK-12 Foundation: Chapter1CrossSectionsandNetsB](#)

Concept Problem Revisited

The net of the first shape is a regular tetrahedron and the second is the net of a regular octahedron.

Vocabulary

A **cross-section** is the intersection of a plane with a solid. A **net** is an unfolded, flat representation of the sides of a three-dimensional shape.

Guided Practice

Describe the shape formed by the intersection of the plane and the regular octahedron.

1.

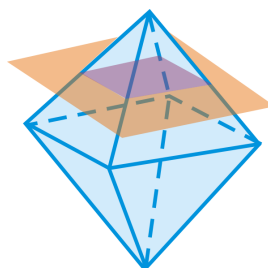

2.

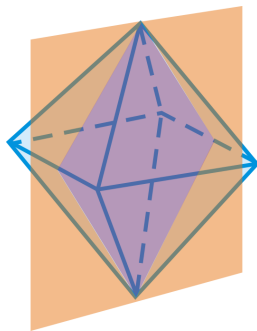

3.

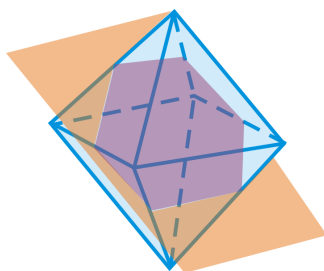

Answers:

1. Square
2. Rhombus
3. Hexagon

Practice

Describe the cross section formed by the intersection of the plane and the solid.

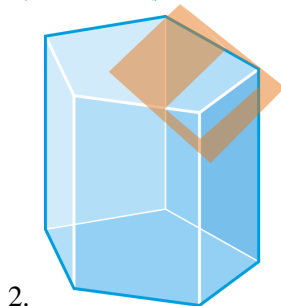
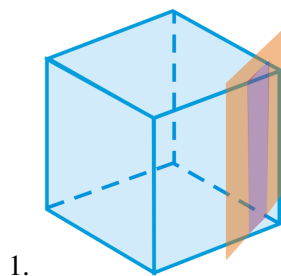

Draw the net for the following solids.

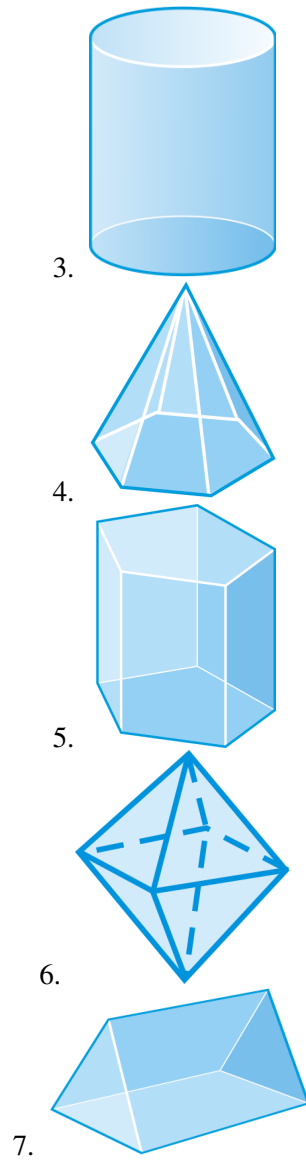

Determine what shape is formed by the following nets.

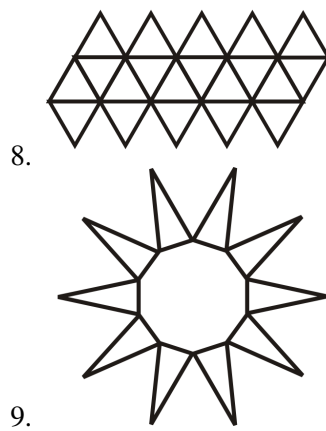

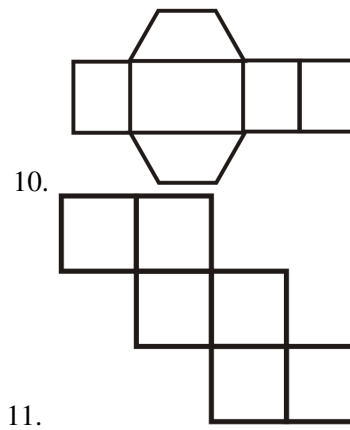

12. A cube has 11 unique nets. Draw 5 different nets of a cube.
13. Use construction tools to construct a large equilateral triangle. Construct the three midsegments of the triangle. Cut out the equilateral triangle and fold along the midsegments. What net have you constructed?
14. Describe a method to construct a net for a regular octahedron.
15. Can you tell what a polyhedron looks like from looking at one cross section?

11.3 Prisms

Here you'll learn what a prism is and how to find its volume and surface area.

What if your family were ready to fill the new pool with water and they didn't know how much water would be needed? The shallow end is 4 ft. and the deep end is 8 ft. The pool is 10 ft. wide by 25 ft. long. How many gallons of water will it take to fill the pool? There are approximately 7.48 gallons in a cubic foot. After completing this Concept, you'll be able to answer this question.

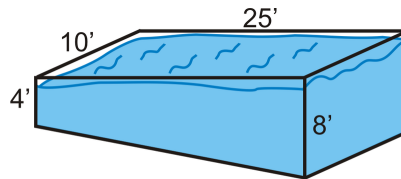

Watch This



MEDIA

Click image to the left for more content.

CK-12 Foundation: Chapter11PrismsA

Learn more about the surface area of prisms by watching the video at this link.

Watch this video to learn about the volume of prisms.

Guidance

A prism is a 3-dimensional figure with 2 congruent bases, in parallel planes with rectangular lateral faces. The edges between the **lateral faces** are called **lateral edges**. All prisms are named by their bases, so the prism below is a pentagonal prism.

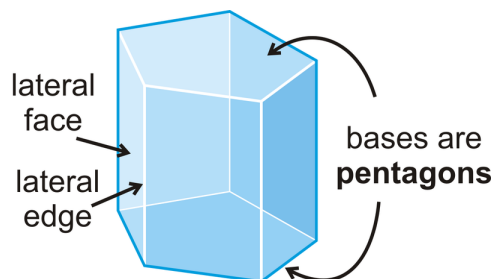

This particular prism is called a **right prism** because the lateral faces are perpendicular to the bases. **Oblique prisms** lean to one side or the other and the height is outside the prism.

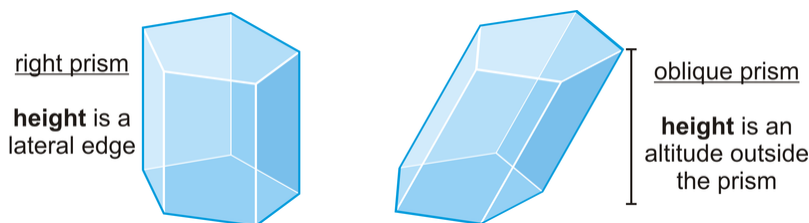

Surface Area

Surface area is the sum of the areas of the faces of a solid.

Surface Area of a Right Prism: The surface area of a right prism is the sum of the area of the bases and the area of each rectangular lateral face.

Volume

Volume is the measure of how much space a three-dimensional figure occupies. The basic unit of volume is the cubic unit: cubic centimeter (cm^3), cubic inch (in^3), cubic meter (m^3), cubic foot (ft^3), etc. Each basic cubic unit has a measure of one for each: length, width, and height.

Volume of a Rectangular Prism: If a rectangular prism is h units high, w units wide, and l units long, then its volume is $V = l \cdot w \cdot h$.

If we further analyze the formula for the volume of a rectangular prism, we would see that $l \cdot w$ is equal to the area of the base of the prism, a rectangle. If the bases are not rectangles, this would still be true, however we would have to rewrite the equation a little.

Volume of a Prism: If the area of the base of a prism is B and the height is h , then the volume is $V = B \cdot h$.

Recall that earlier in this Concept we talked about oblique prisms. These are prisms that lean to one side and the height is outside the prism. What would be the area of an oblique prism? To answer this question, we need to introduce Cavalieri's Principle.

Cavalieri's Principle: If two solids have the same height and the same cross-sectional area at every level, then they will have the same volume.

Basically, if an oblique prism and a right prism have the same base area and height, then they will have the same volume.

Example A

Find the surface area of the prism below.

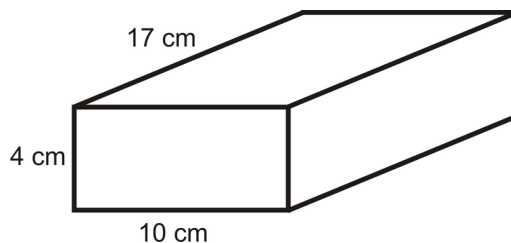

Open up the prism and draw the net. Determine the measurements for each rectangle in the net.

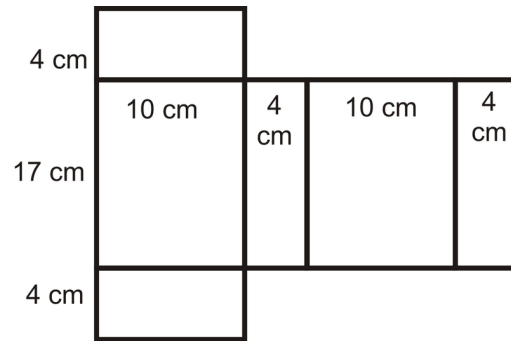

Using the net, we have:

$$\begin{aligned} SA_{prism} &= 2(4)(10) + 2(10)(17) + 2(17)(4) \\ &= 80 + 340 + 136 \\ &= 556 \text{ cm}^2 \end{aligned}$$

Because this is still area, the units are squared.

Example B

Find the surface area of the prism below.

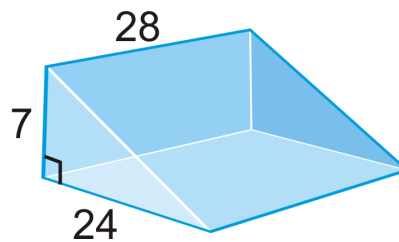

This is a right triangular prism. To find the surface area, we need to find the length of the hypotenuse of the base because it is the width of one of the lateral faces. Using the Pythagorean Theorem, the hypotenuse is

$$\begin{aligned} 7^2 + 24^2 &= c^2 \\ 49 + 576 &= c^2 \\ 625 &= c^2 \\ c &= 25 \end{aligned}$$

Looking at the net, the surface area is:

$$\begin{aligned} SA &= 28(7) + 28(24) + 28(25) + 2\left(\frac{1}{2} \cdot 7 \cdot 24\right) \\ SA &= 196 + 672 + 700 + 168 = 1736 \end{aligned}$$

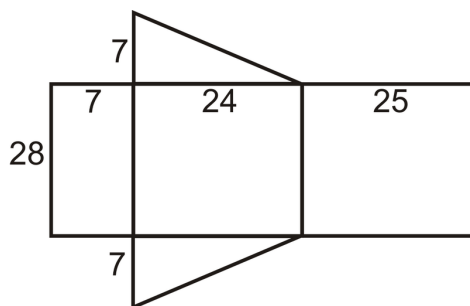

Example C

A typical shoe box is 8 in by 14 in by 6 in. What is the volume of the box?

We can assume that a shoe box is a rectangular prism. Therefore, we can use the formula above.

$$V = (8)(14)(6) = 672 \text{ in}^3$$

Example D

You have a small, triangular prism shaped tent. How much volume does it have, once it is set up?

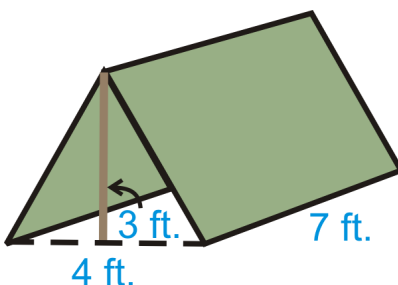

First, we need to find the area of the base. That is going to be $B = \frac{1}{2}(3)(4) = 6 \text{ ft}^2$. Multiplying this by 7 we would get the entire volume. The volume is 42 ft^3 .

Even though the height in this problem does not look like a “height,” it is, when referencing the formula. Usually, the height of a prism is going to be the last length you need to use.

Watch this video for help with the Examples above.



MEDIA

Click image to the left for more content.

[CK-12 Foundation: Chapter11PrismsB](#)

Concept Problem Revisited

Even though it doesn't look like it, the trapezoid is considered the base of this prism. The area of the trapezoids are $\frac{1}{2}(4+8)25 = 150 \text{ ft}^2$. Multiply this by the height, 10 ft, and we have that the volume is 1500 ft^3 . To determine the number of gallons that are needed, divide 1500 by 7.48. $\frac{1500}{7.48} \approx 200.53$ gallons are needed to fill the pool.

Vocabulary

A **prism** is a 3-dimensional figure with 2 congruent bases, in parallel planes, and in which the other faces are rectangles.

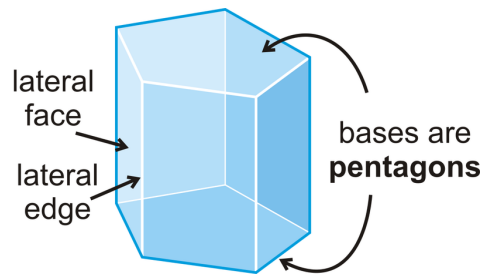

The non-base faces are **lateral faces**. The edges between the lateral faces are **lateral edges**. A **right prism** is a prism where all the lateral faces are perpendicular to the bases. An **oblique prism** is a prism that leans to one side and whose height is perpendicular to the base's plane.

Surface area is a two-dimensional measurement that is the sum of the area of the faces of a solid. **Volume** is a three-dimensional measurement that is a measure of how much three-dimensional space a solid occupies.

Guided Practice

- Find the surface area of the regular pentagonal prism.

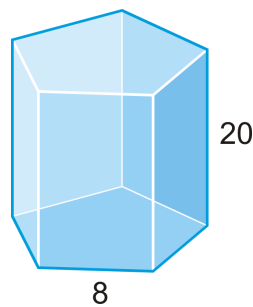

- Find the volume of the right rectangular prism below.

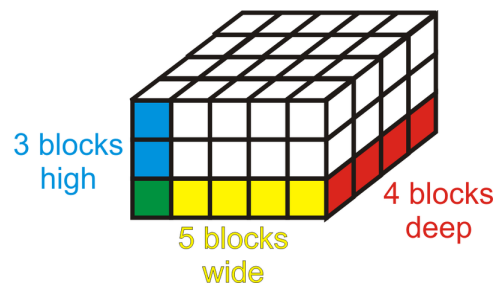

- Find the volume of the regular hexagonal prism below.

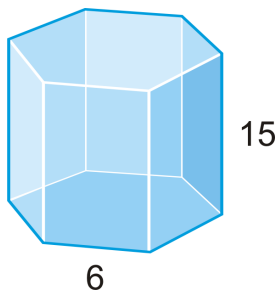

4. Find the area of the oblique prism below.

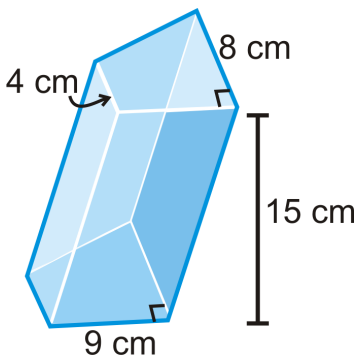

Answers:

1. For this prism, each lateral face has an area of 160 units^2 . Then, we need to find the area of the regular pentagonal bases. Recall that the area of a regular polygon is $\frac{1}{2}asn$. $s = 8$ and $n = 5$, so we need to find a , the apothem.

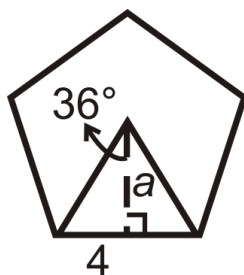

$$\tan 36^\circ = \frac{4}{a}$$

$$a = \frac{4}{\tan 36^\circ} \approx 5.51$$

$$SA = 5(160) + 2\left(\frac{1}{2} \cdot 5.51 \cdot 8 \cdot 5\right) = 1020.4$$

2. A rectangular prism can be made from any square cubes. To find the volume, we would simply count the cubes. The bottom layer has 20 cubes, or 4 times 5, and there are 3 layers, or the same as the height. Therefore there are 60 cubes in this prism and the volume would be 60 units^3 .

3. Recall that a regular hexagon is divided up into six equilateral triangles. The height of one of those triangles would be the apothem. If each side is 6, then half of that is 3 and half of an equilateral triangle is a 30-60-90 triangle. Therefore, the apothem is going to be $3\sqrt{3}$. The area of the base is:

$$B = \frac{1}{2} (3\sqrt{3})(6)(6) = 54\sqrt{3} \text{ units}^2$$

And the volume will be:

$$V = Bh = (54\sqrt{3})(15) = 810\sqrt{3} \text{ units}^3$$

4. This is an oblique right trapezoidal prism. First, find the area of the trapezoid.

$$B = \frac{1}{2}(9)(8+4) = 9(6) = 54 \text{ cm}^2$$

Then, multiply this by the height.

$$V = 54(15) = 810 \text{ cm}^3$$

Practice

Use the right triangular prism to answer questions 1-5.

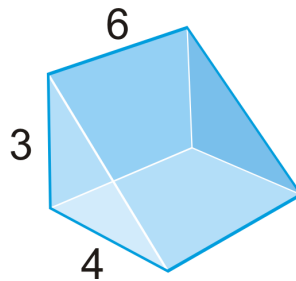

1. What shape are the bases of this prism? What are their areas?
2. What are the dimensions of each of the lateral faces? What are their areas?
3. Find the lateral surface area of the prism.
4. Find the total surface area of the prism.
5. Find the total volume of the prism.
6. **Writing** Describe the difference between lateral surface area and total surface area.
7. Fuzzy dice are cubes with 4 inch sides.



- a. What is the surface area of one die?
- b. Typically, the dice are sold in pairs. What is the surface area of two dice?
- c. What is the volume of both dice?

Find the surface area and volume of the following solids.

8. bases are isosceles trapezoids

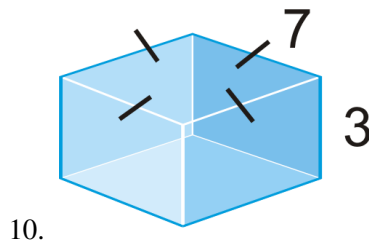
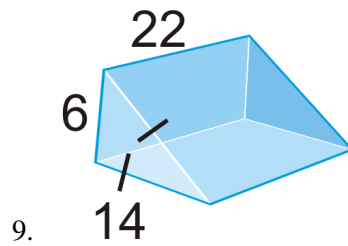
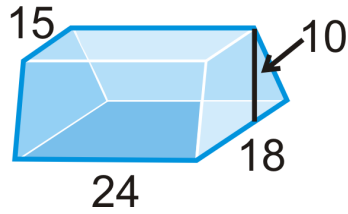

Find the value of x , given the surface area.

11. $SA = 432 \text{ units}^2$

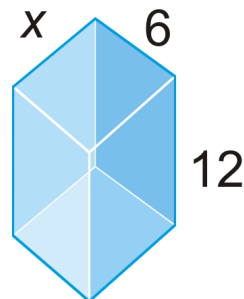

12. $SA = 1568 \text{ units}^2$

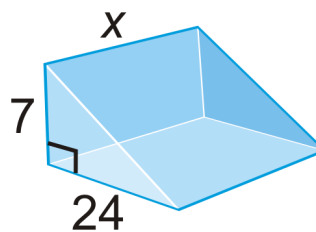

Use the diagram below for questions 13-16. The barn is shaped like a pentagonal prism with dimensions shown in feet.

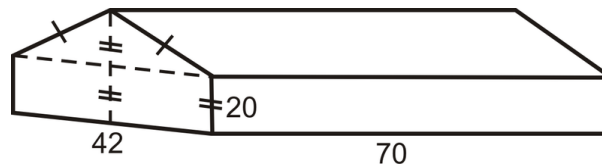

13. What is the area of the roof? (Both sides)
14. What is the floor area of the barn?
15. What is the area of the sides of the barn?
16. What is the total volume of the barn?
17. An open top box is made by cutting out 2 in by 2 in squares from the corners of a large square piece of cardboard. Using the picture as a guide, find an expression for the surface area of the box. If the surface area is 609 in^2 , find the length of x . Remember, there is no top.

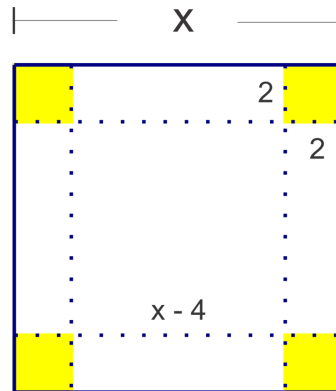

18. How many one-inch cubes can fit into a box that is 8 inches wide, 10 inches long, and 12 inches tall? Is this the same as the volume of the box?
19. A cereal box is 2 inches wide, 10 inches long and 14 inches tall. How much cereal does the box hold?
20. A cube holds 216 in^3 . What is the length of each edge?

11.4 Cylinders

Here you'll learn how to calculate the surface area and volume of cylinders.

What if you wanted to figure out how much paper you needed for the label of a can? How could you use the surface area of a cylinder to help you? After completing this Concept, you'll be able to answer questions like this one.

Watch This



MEDIA

Click image to the left for more content.

[CK-12 Foundation: Chapter11CylindersA](#)

Learn more about the surface area of cylinders by watching the video at this link.

Watch this video to learn about the volume of cylinders.

Guidance

A **cylinder** is a solid with congruent circular bases that are in parallel planes. The space between the circles is enclosed. Just like a circle, the cylinder has a radius for each of the circular bases. Also, like a prism, a cylinder can be oblique, like the one to the right.

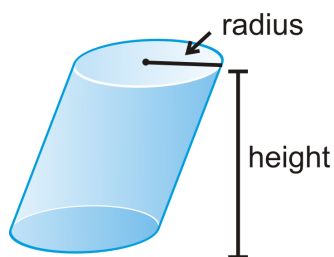
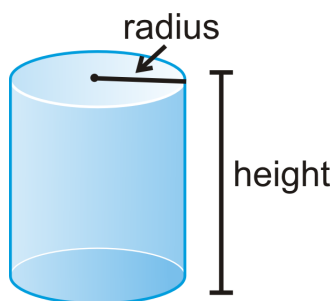

Surface Area

Surface area is the sum of the areas of the faces. Let's find the net of a right cylinder. One way for you to do this is to take a label off of a soup can or can of vegetables. When you take this label off, we see that it is a rectangle where the height is the height of the cylinder and the base is the circumference of the base. This rectangle and the two circular bases make up the net of a cylinder.

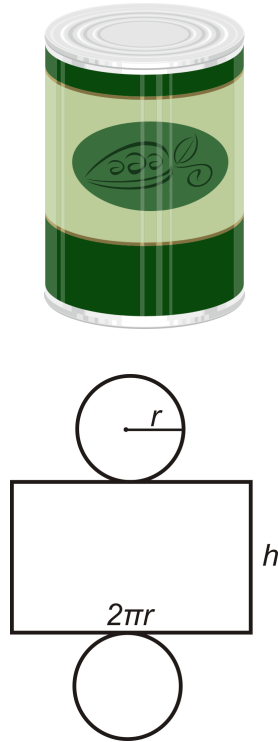

From the net, we can see that the surface area of a right cylinder is

$$\underbrace{2\pi r^2}_{\text{area of both circles}} + \underbrace{2\pi r h}_{\text{length of rectangle}}$$

Surface Area of a Right Cylinder: If r is the radius of the base and h is the height of the cylinder, then the surface area is $SA = 2\pi r^2 + 2\pi r h$.

To see an animation of the surface area, click <http://www.rkm.com.au/ANIMATIONS/animation-Cylinder-Surface-Area-Derivation.html>, by Russell Knightley.

Volume

Volume is the measure of how much space a three-dimensional figure occupies. The basic unit of volume is the cubic unit: cubic centimeter (cm^3), cubic inch (in^3), cubic meter (m^3), cubic foot (ft^3), etc. Each basic cubic unit has a measure of one for each: length, width, and height. The volume of a cylinder is $V = (\pi r^2)h$, where πr^2 is the area of the base.

Volume of a Cylinder: If the height of a cylinder is h and the radius is r , then the volume would be $V = \pi r^2 h$.

If an oblique cylinder has the same base area and height as another cylinder, then it will have the same volume. This is due to Cavalieri's Principle, which states that if two solids have the same height and the same cross-sectional area at every level, then they will have the same volume.

Example A

Find the surface area of the cylinder.

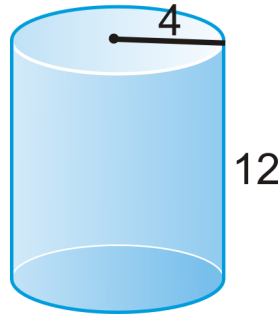

$r = 4$ and $h = 12$. Plug these into the formula.

$$\begin{aligned} SA &= 2\pi(4)^2 + 2\pi(4)(12) \\ &= 32\pi + 96\pi \\ &= 128\pi \end{aligned}$$

Example B

The circumference of the base of a cylinder is 16π and the height is 21. Find the surface area of the cylinder.

If the circumference of the base is 16π , then we can solve for the radius.

$$\begin{aligned} 2\pi r &= 16\pi \\ r &= 8 \end{aligned}$$

Now, we can find the surface area.

$$\begin{aligned} SA &= 2\pi(8)^2 + (16\pi)(21) \\ &= 128\pi + 336\pi \\ &= 464\pi \end{aligned}$$

Example C

Find the volume of the cylinder.

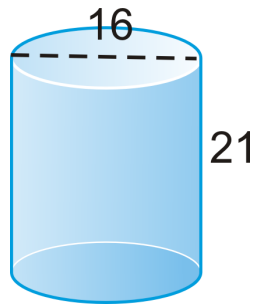

If the diameter is 16, then the radius is 8.

$$V = \pi 8^2(21) = 1344\pi \text{ units}^3$$

Watch this video for help with the Examples above.



MEDIA

Click image to the left for more content.

[CK-12 Foundation: Chapter11CylindersB](#)

Vocabulary

A **cylinder** is a solid with congruent circular bases that are in parallel planes. The space between the circles is enclosed. A cylinder has a **radius** and a **height** and can also be **oblique** (slanted).

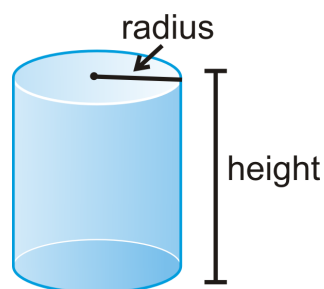

Surface area is a two-dimensional measurement that is the sum of the area of the faces of a solid. **Volume** is a three-dimensional measurement that is a measure of how much three-dimensional space a solid occupies.

Guided Practice

1. Find the volume of the cylinder.

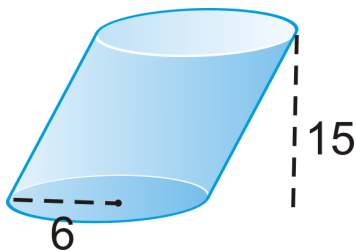

- If the volume of a cylinder is $484\pi \text{ in}^3$ and the height is 4 in, what is the radius?
- Find the volume of the solid below.

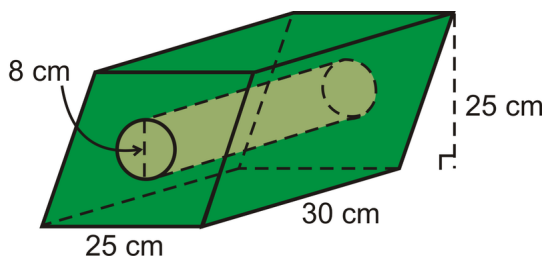

Answers:

- $V = \pi 6^2(15) = 540\pi \text{ units}^3$
- Substitute what you know to the volume formula and solve for r .

$$484\pi = \pi r^2(4)$$

$$121 = r^2$$

$$11 = r$$

- This solid is a parallelogram-based prism with a cylinder cut out of the middle. To find the volume, we need to find the volume of the prism and then subtract the volume of the cylinder.

$$V_{prism} = (25 \cdot 25)30 = 18750 \text{ cm}^3$$

$$V_{cylinder} = \pi(4)^2(30) = 480\pi \text{ cm}^3$$

The total volume is $18750 - 480\pi \approx 17242.04 \text{ cm}^3$.

Practice

- The lateral surface area of a cylinder is what shape? What is the area of this shape?
- A right cylinder has a 7 cm radius and a height of 18 cm. Find the surface area and volume.

Find the surface area and volume of the following solids. Leave answers in terms of π .

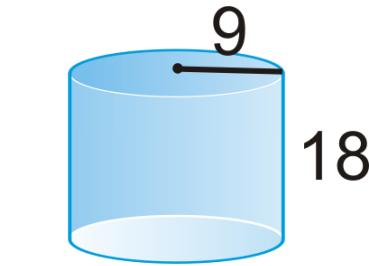

Find the value of x , given the surface area.

5. $SA = 1536\pi \text{ units}^2$

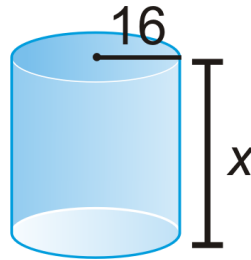

6. The area of the base of a cylinder is $25\pi \text{ in}^2$ and the height is 6 in. Find the *lateral* surface area.
7. The circumference of the base of a cylinder is $80\pi \text{ cm}$ and the height is 36 cm. Find the total surface area.
8. The lateral surface area of a cylinder is $30\pi \text{ m}^2$. What is one possibility for height of the cylinder?
9. Charlie started a business canning artichokes. His cans are 5 in tall and have diameter 4 in. If the label must cover the entire lateral surface of the can and the ends must overlap by at least one inch, what are the dimensions and area of the label?
10. Find an expression for the surface area of a cylinder in which the ratio of the height to the diameter is 2:1. If x is the diameter, use your expression to find x if the surface area is 160π .
11. Two cylinders have the same surface area. Do they have the same volume? How do you know?
12. A can of soda is 4 inches tall and has a diameter of 2 inches. How much soda does the can hold? Round your answer to the nearest hundredth.
13. A cylinder has a volume of $486\pi \text{ ft.}^3$. If the height is 6 ft., what is the diameter?
14. The area of the base of a cylinder is $49\pi \text{ in}^2$ and the height is 6 in. Find the volume.
15. The circumference of the base of a cylinder is $80\pi \text{ cm}$ and the height is 15 cm. Find the volume.
16. The lateral surface area of a cylinder is $30\pi \text{ m}^2$ and the circumference is $10\pi \text{ m}$. What is the volume of the cylinder?

11.5 Pyramids

Here you'll learn how to calculate the surface area and volume of a pyramid.

What if you wanted to know the volume of an Egyptian Pyramid? The Khafre Pyramid is the second largest pyramid of the Ancient Egyptian Pyramids in Giza. It is a square pyramid with a base edge of 706 feet and an original height of 407.5 feet. What was the original volume of the Khafre Pyramid? After completing this Concept, you'll be able to answer this question.



Watch This



MEDIA

Click image to the left for more content.

[CK-12 Foundation: Chapter11PyramidsA](#)

Learn more about the surface area of pyramids by watching the video at this link.

Follow this link to watch a video about the volume of pyramids.

Guidance

A pyramid has one **base** and all the **lateral faces** meet at a common **vertex**. The edges between the lateral faces are **lateral edges**. The edges between the base and the lateral faces are called **base edges**. If we were to draw the height of the pyramid to the right, it would be off to the left side.

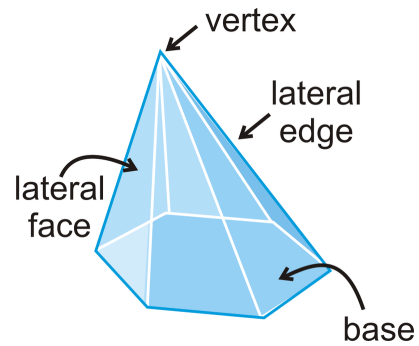

When a pyramid has a height that is directly in the center of the base, the pyramid is said to be **regular**. These pyramids have a regular polygon as the base. All regular pyramids also have a **slant height** that is the height of a lateral face. Because of the nature of regular pyramids, all slant heights are congruent. A non-regular pyramid does not have a slant height.

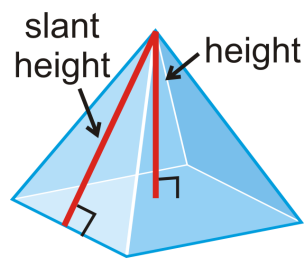

Surface Area

Using the slant height, which is usually labeled l , the area of each triangular face is $A = \frac{1}{2}bl$.

Surface Area of a Regular Pyramid: If B is the area of the base and P is the perimeter of the base and l is the slant height, then $SA = B + \frac{1}{2}Pl$.

If you ever forget this formula, use the net. Each triangular face is congruent, plus the area of the base. This way, you do not have to remember a formula, just a process, which is the same as finding the area of a prism.

Volume

Recall that the volume of a prism is Bh , where B is the area of the base. The volume of a pyramid is closely related to the volume of a prism with the same sized base. **Investigation: Finding the Volume of a Pyramid**

Tools needed: pencil, paper, scissors, tape, ruler, dry rice or sand.

1. Make an open net (omit one base) of a cube, with 2 inch sides.

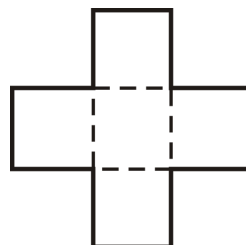

2. Cut out the net and tape up the sides to form an open cube.

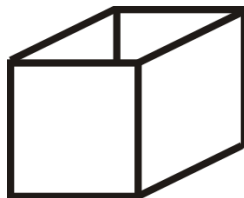

3. Make an open net (no base) of a square pyramid, with lateral edges of 2.45 inches and base edges of 2 inches. This will make the overall height 2 inches.

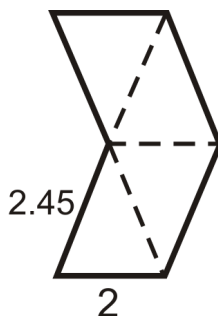

4. Cut out the net and tape up the sides to form an open pyramid.

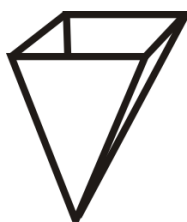

5. Fill the pyramid with dry rice. Then, dump the rice into the open cube. How many times do you have to repeat this to fill the cube?

Volume of a Pyramid: If B is the area of the base and h is the height, then the volume of a pyramid is $V = \frac{1}{3}Bh$.

The investigation showed us that you would need to repeat this process three times to fill the cube. This means that the pyramid is one-third the volume of a prism with the same base.

Example A

Find the slant height of the square pyramid.

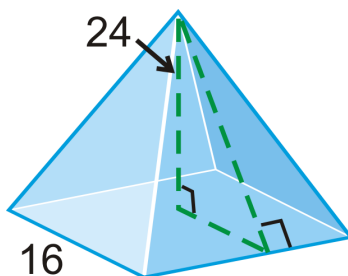

Notice that the slant height is the hypotenuse of a right triangle formed by the height and half the base length. Use the Pythagorean Theorem.

$$\begin{aligned}
 8^2 + 24^2 &= l^2 \\
 64 + 576 &= l^2 \\
 640 &= l^2 \\
 l &= \sqrt{640} = 8\sqrt{10}
 \end{aligned}$$

Example B

Find the surface area of the pyramid from Example A.

The surface area of the four triangular faces are $4\left(\frac{1}{2}bl\right) = 2(16)\left(8\sqrt{10}\right) = 256\sqrt{10}$. To find the total surface area, we also need the area of the base, which is $16^2 = 256$. The total surface area is $256\sqrt{10} + 256 \approx 1065.54$.

Example C

Find the volume of the pyramid.

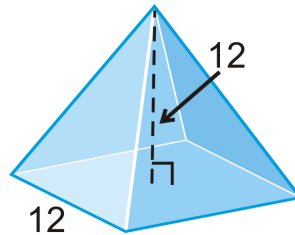

$$V = \frac{1}{3}(12^2)12 = 576 \text{ units}^3$$

Watch this video for help with the Examples above.



MEDIA

Click image to the left for more content.

[CK-12 Foundation: Chapter11PyramidsB](#)

Concept Problem Revisited

The original volume of the pyramid is $\frac{1}{3}(706^2)(407.5) \approx 67,704,223.33 \text{ ft}^3$.

Vocabulary

A *pyramid* is a solid with one *base* and *lateral faces* that meet at a common *vertex*. The edges between the lateral faces are *lateral edges*. The edges between the base and the lateral faces are *base edges*.

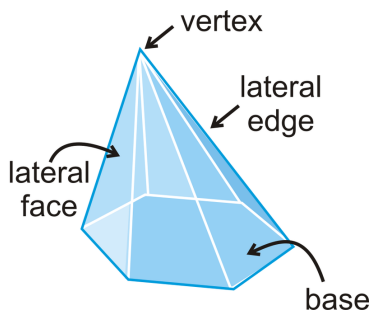

A **regular pyramid** is a pyramid where the base is a regular polygon. All regular pyramids also have a **slant height**, which is the height of a lateral face.

Surface area is a two-dimensional measurement that is the total area of all surfaces that bound a solid. **Volume** is a three-dimensional measurement that is a measure of how much three-dimensional space a solid occupies.

Guided Practice

1. Find the area of the regular triangular pyramid.

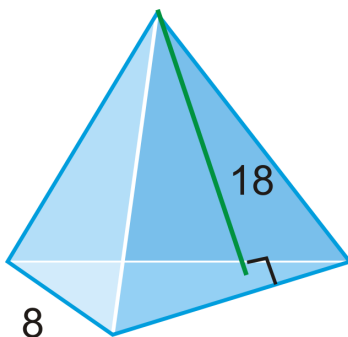

2. If the lateral surface area of a square pyramid is 72 ft^2 and the base edge is equal to the slant height, what is the length of the base edge?
3. Find the area of the regular hexagonal pyramid below.

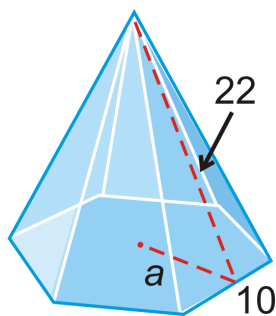

4. Find the volume of the pyramid.

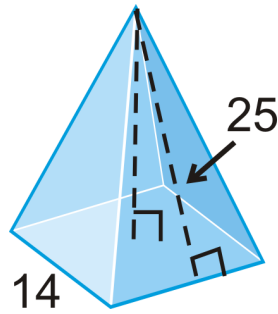

5. Find the volume of the pyramid.

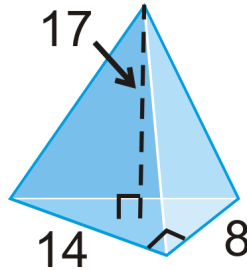

6. A rectangular pyramid has a base area of 56 cm^2 and a volume of 224 cm^3 . What is the height of the pyramid?

Answers:

1. The area of the base is $A = \frac{1}{4}s^2 \sqrt{3}$ because it is an equilateral triangle.

$$B = \frac{1}{4}8^2 \sqrt{3} = 16 \sqrt{3}$$

$$SA = 16 \sqrt{3} + \frac{1}{2}(24)(18) = 16 \sqrt{3} + 216 \approx 243.71$$

2. In the formula for surface area, the lateral surface area is $\frac{1}{2}Pl$ or $\frac{1}{2}nbl$. We know that $n = 4$ and $b = l$. Let's solve for b .

$$\frac{1}{2}nbl = 72 \text{ ft}^2$$

$$\frac{1}{2}(4)b^2 = 72$$

$$2b^2 = 72$$

$$b^2 = 36$$

$$b = 6$$

Therefore, the base edges are all 6 units and the slant height is also 6 units.

3. To find the area of the base, we need to find the apothem. If the base edges are 10 units, then the apothem is $5\sqrt{3}$ for a regular hexagon. The area of the base is $\frac{1}{2}asn = \frac{1}{2}(5\sqrt{3})(10)(6) = 150\sqrt{3}$. The total surface area is:

$$\begin{aligned} SA &= 150\sqrt{3} + \frac{1}{2}(6)(10)(22) \\ &= 150\sqrt{3} + 660 \approx 919.81 \text{ units}^2 \end{aligned}$$

4. In this example, we are given the slant height. For volume, we need the height, so we need to use the Pythagorean Theorem to find it.

$$7^2 + h^2 = 25^2$$

$$h^2 = 576$$

$$h = 24$$

Using the height, the volume is $\frac{1}{3}(14^2)(24) = 1568 \text{ units}^3$.

5. The base of this pyramid is a right triangle. So, the area of the base is $\frac{1}{2}(14)(8) = 56 \text{ units}^2$.

$$V = \frac{1}{3}(56)(17) \approx 317.33 \text{ units}^3$$

6. The formula for the volume of a pyramid works for any pyramid, as long as you can find the area of the base.

$$224 = 56h$$

$$4 = h$$

Practice

Fill in the blanks about the diagram below.

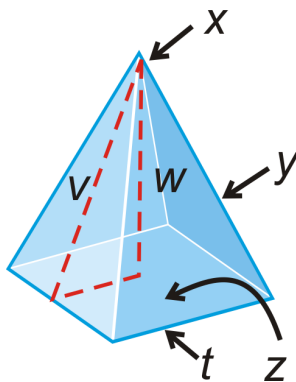

1. x is the _____.
2. The slant height is _____.
3. y is the _____.
4. The height is _____.
5. The base is _____.
6. The base edge is _____.

Find the area of a lateral face and the volume of the regular pyramid. Leave your answer in simplest radical form.

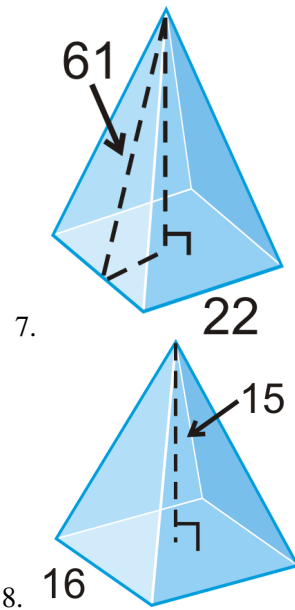

Find the surface area and volume of the regular pyramids. Round your answers to 2 decimal places.

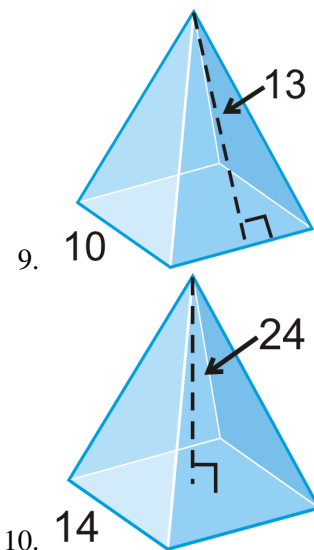

11. A **regular tetrahedron** has four equilateral triangles as its faces. Find the surface area of a regular tetrahedron with edge length of 6 units.
12. Using the formula for the area of an equilateral triangle, what is the surface area of a regular tetrahedron, with edge length s ?

For questions 13-15 consider a square with diagonal length $10\sqrt{2}$ in.

13. What is the length of a side of the square?
14. If this square is the base of a right pyramid with height 12, what is the slant height of the pyramid?
15. What is the surface area of the pyramid?

A **regular tetrahedron** has four equilateral triangles as its faces. Use the diagram to answer questions 16-19.

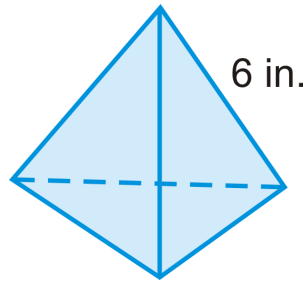

16. What is the area of the base of this regular tetrahedron?
17. What is the height of this figure? Be careful!
18. Find the volume. Leave your answer in simplest radical form.
19. **Challenge** If the sides are length s , what is the volume?

A **regular octahedron** has eight equilateral triangles as its faces. Use the diagram to answer questions 20-22.

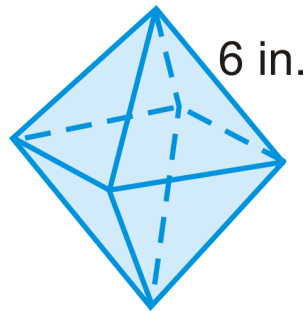

20. *Describe* how you would find the volume of this figure.
21. Find the volume. Leave your answer in simplest radical form.
22. **Challenge** If the sides are length s , what is the volume?

11.6 Cones

Here you'll learn what a cone is and how to find its volume and surface area.

What if you wanted to use your mathematical prowess to figure out exactly how much waffle cone your friend Jeff is eating? This happens to be your friend Jeff's favorite part of his ice cream dessert. A typical waffle cone is 6 inches tall and has a diameter of 2 inches. What is the surface area of the waffle cone? (You may assume that the cone is straight across at the top). Jeff decides he wants a "king size" cone, which is 8 inches tall and has a diameter of 4 inches. What is the surface area of this cone? After completing this Concept, you'll be able to answer questions like these.



Watch This



MEDIA

Click image to the left for more content.

[CK-12 Foundation: Chapter11ConesA](#)

Learn more about the surface area of cones by watching the video at [this link](#).

Watch this video to learn about the volume of cones.

Guidance

A **cone** is a solid with a circular base and sides taper up towards a common vertex.

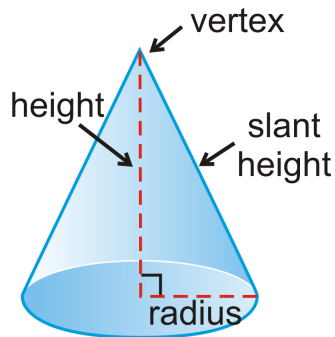

It is said that a cone is generated from rotating a right triangle around one leg in a circle. Notice that a cone has a slant height, just like a pyramid.

Surface Area

We know that the base is a circle, but we need to find the formula for the curved side that tapers up from the base. Unfolding a cone, we have the net:

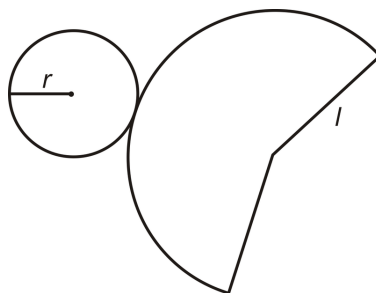

From this, we can see that the lateral face's edge is $2\pi r$ and the sector of a circle with radius l . We can find the area of the sector by setting up a proportion.

$$\frac{\text{Area of circle}}{\text{Area of sector}} = \frac{\text{Circumference}}{\text{Arc length}}$$

$$\frac{\pi l^2}{\text{Area of sector}} = \frac{2\pi l}{2\pi r} = \frac{l}{r}$$

Cross multiply:

$$l(\text{Area of sector}) = \pi r l^2$$

$$\text{Area of sector} = \pi r l$$

Surface Area of a Right Cone: The surface area of a right cone with slant height l and base radius r is $SA = \pi r^2 + \pi r l$.

Volume

If the bases of a cone and a cylinder are the same, then the volume of a cone will be one-third the volume of the cylinder.

Volume of a Cone: If r is the radius of a cone and h is the height, then the volume is $V = \frac{1}{3}\pi r^2 h$.

Example A

What is the surface area of the cone?

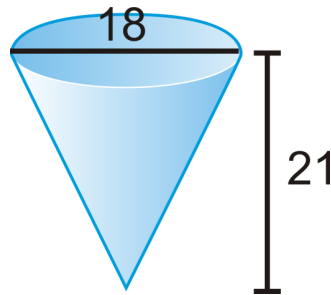

In order to find the surface area, we need to find the slant height. Recall from a pyramid, that the slant height forms a right triangle with the height and the radius. Use the Pythagorean Theorem.

$$\begin{aligned} l^2 &= 9^2 + 21^2 \\ &= 81 + 441 \\ l &= \sqrt{522} \approx 22.85 \end{aligned}$$

The surface area would be $SA = \pi 9^2 + \pi(9)(22.85) \approx 900.54 \text{ units}^2$.

Example B

The surface area of a cone is 36π and the slant height is 5 units. What is the radius?

Plug in what you know into the formula for the surface area of a cone and solve for r .

$$\begin{aligned} 36\pi &= \pi r^2 + \pi r(5) \\ 36 &= r^2 + 5r \\ r^2 + 5r - 36 &= 0 \\ (r - 4)(r + 9) &= 0 \end{aligned}$$

Because every term has π , we can cancel it out.

Set one side equal to zero, and this becomes a factoring problem.

The possible answers for r are 4 and -9 . The radius must be positive, so our answer is 4.

Example C

Find the volume of the cone.

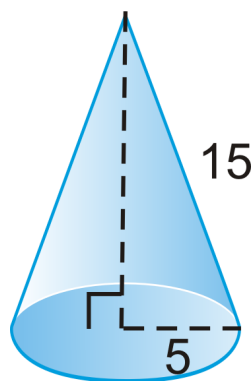

To find the volume, we need the height, so we have to use the Pythagorean Theorem.

$$\begin{aligned}5^2 + h^2 &= 15^2 \\h^2 &= 200 \\h &= 10\sqrt{2}\end{aligned}$$

Now, we can find the volume.

$$V = \frac{1}{3}(5^2)(10\sqrt{2})\pi \approx 370.24$$

Watch this video for help with the Examples above.



MEDIA

Click image to the left for more content.

[CK-12 Foundation: Chapter11ConesB](#)

Concept Problem Revisited

The standard cone has a surface area of $\pi + 6\pi = 7\pi \approx 21.99 \text{ in}^2$. The “king size” cone has a surface area of $4\pi + 16\pi = 20\pi \approx 62.83$, almost three times as large as the standard cone.

Vocabulary

A **cone** is a solid with a circular base and sides that taper up towards a vertex. A cone has a **slant height**.

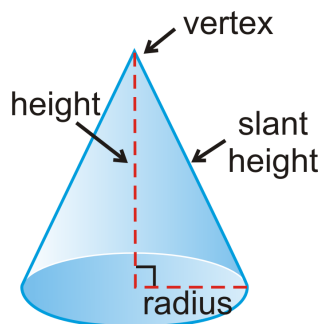

Surface area is a two-dimensional measurement that is the total area of all surfaces that bound a solid. **Volume** is a three-dimensional measurement that is a measure of how much three-dimensional space a solid occupies.

Guided Practice

1. Find the volume of the cone.

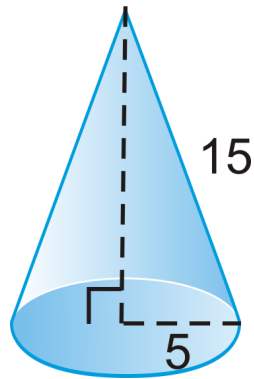

2. Find the volume of the cone.

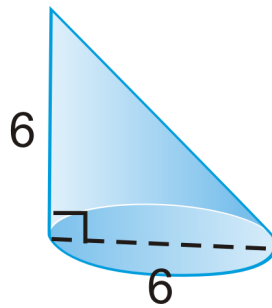

3. The volume of a cone is $484\pi \text{ cm}^3$ and the height is 12 cm. What is the radius?

Answers:

1. To find the volume, we need the height, so we have to use the Pythagorean Theorem.

$$\begin{aligned}5^2 + h^2 &= 15^2 \\h^2 &= 200 \\h &= 10\sqrt{2}\end{aligned}$$

Now, we can find the volume.

$$V = \frac{1}{3}(5^2)(10\sqrt{2})\pi \approx 370.24$$

2. Use the *radius* in the formula.

$$V = \frac{1}{3}\pi(3^2)(6) = 18\pi \approx 56.55$$

3. Plug in what you know to the volume formula.

$$\begin{aligned}484\pi &= \frac{1}{3}\pi r^2(12) \\121 &= r^2 \\11 &= r\end{aligned}$$

Practice

Find the surface area and volume of the right cones. Leave your answers in terms of π .

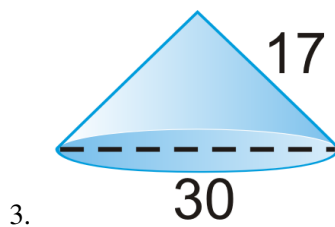
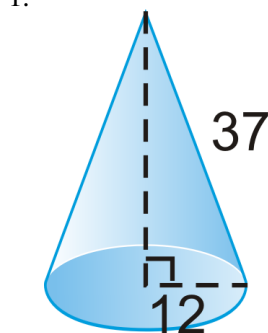
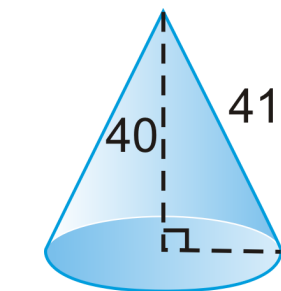

Challenge Find the surface area of the traffic cone with the given information. The cone is cut off at the top (4 inch cone) and the base is a square with sides of length 24 inches. Round answers to the nearest hundredth.

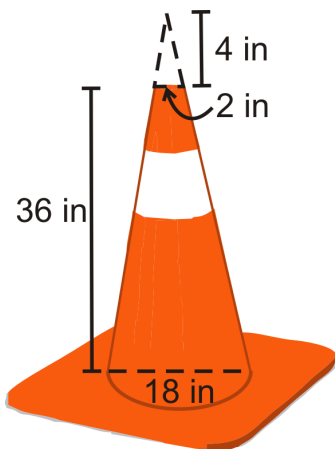

- Find the area of the entire square. Then, subtract the area of the base of the cone.
- Find the lateral area of the cone portion (include the 4 inch cut off top of the cone).
- Now, subtract the cut-off top of the cone, to only have the lateral area of the cone portion of the traffic cone.
- Combine your answers from #4 and #6 to find the entire surface area of the traffic cone.

For questions 8-11, consider the sector of a circle with radius 25 cm and arc length 14π .

8. What is the central angle of this sector?
9. If this sector is rolled into a cone, what are the radius and area of the base of the cone?
10. What is the height of this cone?
11. What is the total surface area of the cone?

Find the volume of the following cones. Leave your answers in terms of π .

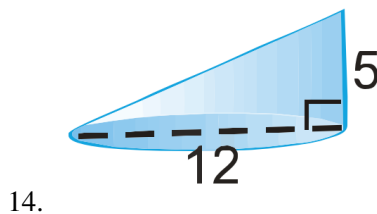
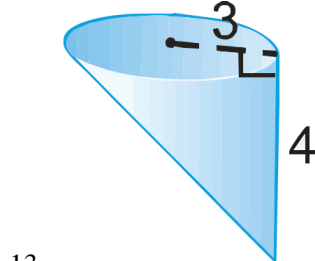
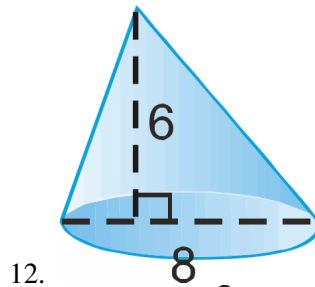

15. If the volume of a cone is $30\pi \text{ cm}^2$ and the radius is 5 cm, what is the height?
16. If the volume of a cone is $105\pi \text{ cm}^2$ and the height is 35 cm, what is the radius?
17. A teepee is to be built such that there is a minimal cylindrical shaped central living space contained within the cone shape of diameter 6 ft and height 6 ft. If the radius of the entire teepee is 5 ft, find the total height of the teepee.

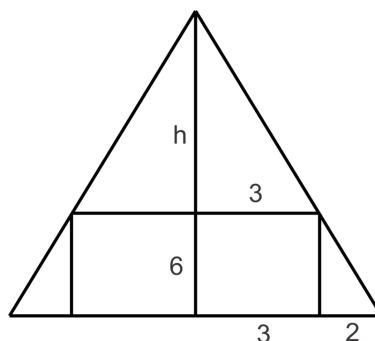



11.7 Spheres

Here you'll learn how to calculate the volume and surface area of a sphere.

What if you were asked to geometrically consider a bowling ball? A regulation bowling ball is a sphere that weighs between 12 and 16 pounds. The maximum circumference of a bowling ball is 27 inches. Using this number, find the radius, surface area, and volume of the bowling ball. You may assume the bowling ball does not have any finger holes. Round your answers to the nearest hundredth. After completing this Concept, you'll be able to answer questions like these.

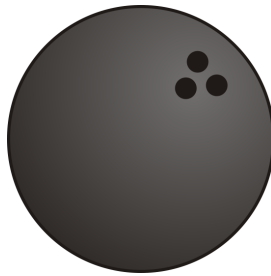

Watch This



MEDIA

Click image to the left for more content.

[CK-12 Foundation: Chapter 11 Spheres A](#)

[Watch this video to learn more about the surface area of spheres.](#)

[Follow this link to watch a video about the volume of a sphere.](#)

Guidance

A **sphere** is the set of all points, in three-dimensional space, which are equidistant from a point. You can think of a sphere as a three-dimensional circle. A sphere has a **center**, **radius** and **diameter**, just like a circle. The **radius** has an endpoint on the sphere and the other is on the center. The **diameter** must contain the center. If it does not, it is a **chord**. The **great circle** is a plane that contains the diameter. It is the largest circle cross section in a sphere. There are infinitely many great circles. The circumference of a sphere is the circumference of a great circle. Every great circle divides a sphere into two congruent hemispheres, or two half spheres. Also like a circle, spheres can have tangent lines and secants. These are defined just like they are in a circle.

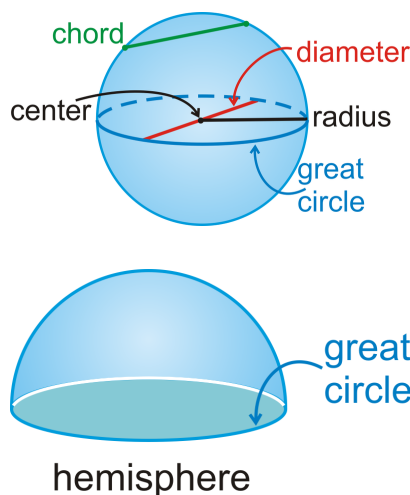

Surface Area

Surface area is a two-dimensional measurement that is the total area of all surfaces that bound a solid. The basic unit of area is the square unit. One way to find the formula for the surface area of a sphere is to look at a baseball. We can best *approximate* the cover of the baseball by 4 circles. The area of a circle is πr^2 , so the surface area of a sphere is $4\pi r^2$. While the covers of a baseball are not four perfect circles, they are stretched and skewed.



Another way to show the surface area of a sphere is to watch the link by Russell Knightley, <http://www.rkm.com.au/ANIMATIONS/animation-Sphere-Surface-Area-Derivation.html>. It is a great visual interpretation of the formula.

Surface Area of a Sphere: If r is the radius, then the surface area of a sphere is $SA = 4\pi r^2$.

Volume

To find the volume of any solid you must figure out how much space it occupies. The basic unit of volume is the cubic unit. A sphere can be thought of as a regular polyhedron with an infinite number of congruent regular polygon faces. As n , the number of faces increases to an infinite number, the figure approaches becoming a sphere. So a sphere can be thought of as a polyhedron with an infinite number faces. Each of those faces is the base of a pyramid whose vertex is located at the center of the sphere. Each of the pyramids that make up the sphere would be congruent to the pyramid shown. The volume of this pyramid is given by $V = \frac{1}{3}Bh$.



To find the volume of the sphere, you need to add up the volumes of an infinite number of infinitely small pyramids.

$$\begin{aligned} V(\text{all pyramids}) &= V_1 + V_2 + V_3 + \dots + V_n \\ &= \frac{1}{3}(B_1h + B_2h + B_3h + \dots + B_nh) \\ &= \frac{1}{3}h(B_1 + B_2 + B_3 + \dots + B_n) \end{aligned}$$

The sum of all of the bases of the pyramids is the surface area of the sphere. Since you know that the surface area of the sphere is $4\pi r^2$, you can substitute this quantity into the equation above.

$$= \frac{1}{3}h(4\pi r^2)$$

In the picture above, we can see that the height of each pyramid is the radius, so $h = r$.

$$\begin{aligned} &= \frac{4}{3}r(\pi r^2) \\ &= \frac{4}{3}\pi r^3 \end{aligned}$$

To see an animation of the volume of a sphere, see <http://www.rkm.com.au/ANIMATIONS/animation-Sphere-Volume-Derivation.html> by Russell Knightley. It is a slightly different interpretation than our derivation.

Volume of a Sphere: If a sphere has a radius r , then the volume of a sphere is $V = \frac{4}{3}\pi r^3$.

Example A

The circumference of a sphere is 26π feet. What is the radius of the sphere?

The circumference is referring to the circumference of a great circle. Use $C = 2\pi r$.

$$\begin{aligned} 2\pi r &= 26\pi \\ r &= 13 \text{ ft.} \end{aligned}$$

Example B

Find the surface area of a sphere with a radius of 14 feet.

Use the formula, $r = 14$ ft.

$$\begin{aligned} SA &= 4\pi(14)^2 \\ &= 784\pi \text{ ft}^2 \end{aligned}$$

Example C

Find the volume of a sphere with a radius of 6 m.

Use the formula for the volume of a sphere.

$$\begin{aligned} V &= \frac{4}{3}\pi 6^3 \\ &= \frac{4}{3}\pi(216) \\ &= 288\pi \end{aligned}$$

Watch this video for help with the Examples above.

**MEDIA**

Click image to the left for more content.

[CK-12 Foundation: Chapter11SpheresB](#)

Concept Problem Revisited

If the maximum circumference of a bowling ball is 27 inches, then the maximum radius would be $27 = 2\pi r$, or $r = 4.30$ inches. Therefore, the surface area would be $4\pi 4.3^2 \approx 232.35 \text{ in}^2$, and the volume would be $\frac{4}{3}\pi 4.3^3 \approx 333.04 \text{ in}^3$. The weight of the bowling ball refers to its density, how heavy something is. The volume of the ball tells us how much it can hold.

Vocabulary

A **sphere** is the set of all points, in three-dimensional space, which are equidistant from a point. The **radius** has one endpoint on the sphere and the other endpoint at the center of that sphere. The **diameter** of a sphere must contain the center. The **great circle** is a plane that contains the diameter. A **hemisphere** is half of a sphere.

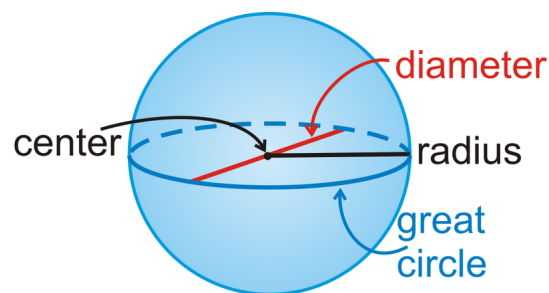

Surface area is a two-dimensional measurement that is the total area of all surfaces that bound a solid. **Volume** is a three-dimensional measurement that is a measure of how much three-dimensional space a solid occupies.

Guided Practice

1. Find the surface area of the figure below.

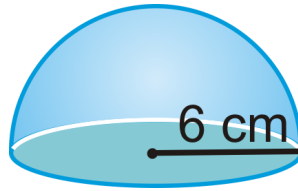

2. The surface area of a sphere is $100\pi \text{ in}^2$. What is the radius?
 3. A sphere has a volume of 14137.167 ft^3 , what is the radius?

Answers:

1. This is a hemisphere. Be careful when finding the surface area of a hemisphere because you need to include the area of the base. If the question asked for the *lateral surface area*, then your answer would *not* include the bottom.

$$\begin{aligned} SA &= \pi r^2 + \frac{1}{2}4\pi r^2 \\ &= \pi(6^2) + 2\pi(6^2) \\ &= 36\pi + 72\pi = 108\pi \text{ cm}^2 \end{aligned}$$

2. Plug in what you know to the formula and solve for r .

$$\begin{aligned} 100\pi &= 4\pi r^2 \\ 25 &= r^2 \\ 5 &= r \end{aligned}$$

3. Because we have a decimal, our radius might be an approximation. Plug in what you know to the formula and solve for r .

$$\begin{aligned} 14137.167 &= \frac{4}{3}\pi r^3 \\ \frac{3}{4\pi} \cdot 14137.167 &= r^3 \\ 3375 &= r^3 \end{aligned}$$

At this point, you will need to take the **cubed root** of 3375. Depending on your calculator, you can use the $\sqrt[3]{x}$ function or $\wedge (\frac{1}{3})$. The cubed root is the inverse of cubing a number, just like the square root is the inverse, or how you undo, the square of a number.

$$\sqrt[3]{3375} = 15 = r \quad \text{The radius is } 15 \text{ ft.}$$

Practice

1. Are there any cross-sections of a sphere that are not a circle? Explain your answer.

Find the surface area and volume of a sphere with: (Leave your answer in terms of π)

2. a radius of 8 in.
3. a diameter of 18 cm.
4. a radius of 20 ft.
5. a diameter of 4 m.
6. a radius of 15 ft.
7. a diameter of 32 in.
8. a circumference of 26π cm.
9. a circumference of 50π yds.
10. The surface area of a sphere is 121π in². What is the radius?
11. The volume of a sphere is 47916π m³. What is the radius?
12. The surface area of a sphere is 4π ft². What is the volume?
13. The volume of a sphere is 36π mi³. What is the surface area?
14. Find the radius of the sphere that has a volume of 335 cm³. Round your answer to the nearest hundredth.
15. Find the radius of the sphere that has a surface area 225π ft².
16. At the age of 81, Mr. Luke Roberts began collecting string. He had a ball of string 3 feet in diameter.
 - a. Find the volume of Mr. Roberts' ball of string in cubic inches.
 - b. Assuming that each cubic inch weighs 0.03 pounds, find the weight of his ball of string.
 - c. To the nearest inch, how big (diameter) would a 1 ton ball of string be? (1 ton = 2000 lbs)

For problems 17-19, use the fact that the earth's radius is approximately 4,000 miles.

17. Find the length of the equator.
18. Find the surface area of earth, rounding your answer to the nearest million square miles.
19. Find the volume of the earth, rounding your answer to the nearest billion cubic miles.

11.8 Composite Solids

Here you'll learn what a composite solid is and how to find its volume and surface area.

What if you built a solid three-dimensional house model consisting of a pyramid on top of a square prism? How could you determine how much two-dimensional and three-dimensional space that model occupies? After completing this Concept, you'll be able to find the surface area and volume of composite solids like this one.

Watch This



MEDIA

Click image to the left for more content.

[CK-12 Foundation: Chapter 11 Composite Solids A](#)

Learn more about the surface area of joined solids by watching the video at [this link](#).

Guidance

A **composite solid** is a solid that is composed, or made up of, two or more solids. The solids that it is made up of are generally prisms, pyramids, cones, cylinders, and spheres. In order to find the surface area and volume of a composite solid, you need to know how to find the surface area and volume of prisms, pyramids, cones, cylinders, and spheres. For more information on any of those specific solids, consult the Concept that focuses on them. This Concept will assume knowledge of those five solids.

Example A

Find the volume of the solid below.

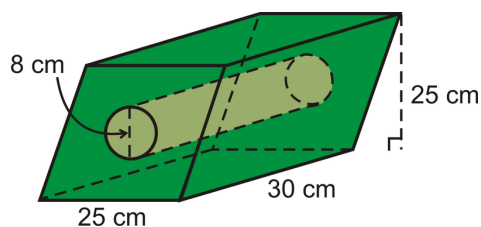

This solid is a parallelogram-based prism with a cylinder cut out of the middle.

$$V_{prism} = (25 \cdot 25)30 = 18,750 \text{ cm}^3$$

$$V_{cylinder} = \pi(4)^2(30) = 480\pi \text{ cm}^3$$

The total volume is $18750 - 480\pi \approx 17,242.04 \text{ cm}^3$.

Example B

Find the surface area of the following solid.

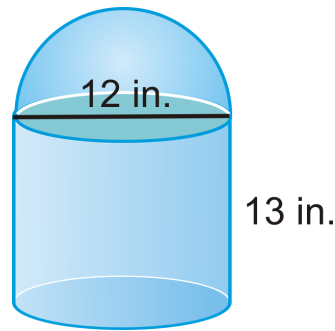

This solid is a cylinder with a hemisphere on top. Because it is one fluid solid, we would not include the bottom of the hemisphere or the top of the cylinder because they are no longer on the surface of the solid. Below, “*LA*” stands for *lateral area*.

$$\begin{aligned}
 SA &= LA_{cylinder} + LA_{hemisphere} + A_{base\ circle} \\
 &= \pi r h + \frac{1}{2} 4\pi r^2 + \pi r^2 \\
 &= \pi(6)(13) + 2\pi 6^2 + \pi 6^2 \\
 &= 78\pi + 72\pi + 36\pi \\
 &= 186\pi\ in^2
 \end{aligned}$$

Example C

Find the volume of the following solid.

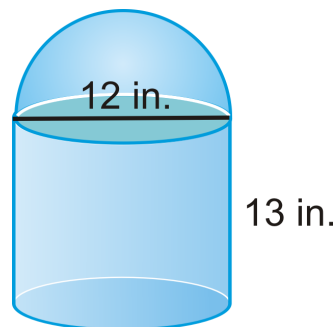

To find the volume of this solid, we need the volume of a cylinder and the volume of the hemisphere.

$$\begin{aligned}
 V_{cylinder} &= \pi 6^2(13) = 78\pi \\
 V_{hemisphere} &= \frac{1}{2} \left(\frac{4}{3} \pi 6^3 \right) = 36\pi \\
 V_{total} &= 78\pi + 36\pi = 114\pi\ in^3
 \end{aligned}$$

Watch this video for help with the Examples above.



MEDIA

Click image to the left for more content.

CK-12 Foundation: Chapter 11 Composite Solids B

Vocabulary

A **composite solid** is a solid that is composed, or made up of, two or more solids. **Surface area** is a two-dimensional measurement that is the total area of all surfaces that bound a solid. **Volume** is a three-dimensional measurement that is a measure of how much three-dimensional space a solid occupies.

Guided Practice

1. Find the volume of the composite solid. All bases are squares.

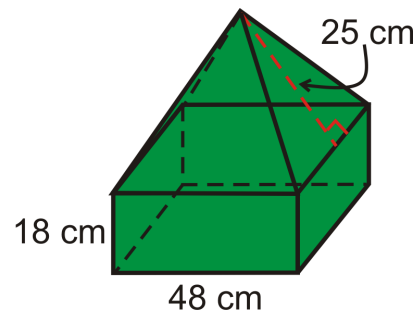

2. Find the volume of the base prism. Round your answer to the nearest hundredth.

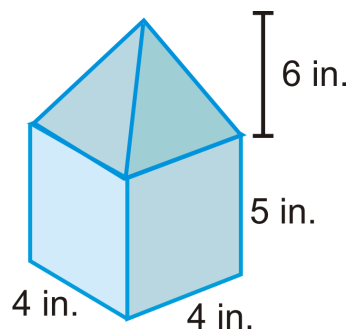

3. Using your work from #2, find the volume of the pyramid and then of the entire solid.

Answers:

1. This is a square prism with a square pyramid on top. Find the volume of each separately and then add them together to find the total volume. First, we need to find the height of the pyramid portion. The slant height is 25 and the edge is 48. Using half of the edge, we have a right triangle and we can use the Pythagorean Theorem.

$$h = \sqrt{25^2 - 24^2} = 7$$

$$V_{prism} = (48)(48)(18) = 41472 \text{ cm}^3$$

$$V_{pyramid} = \frac{1}{3}(48^2)(7) = 5376 \text{ cm}^3$$

The total volume is $41472 + 5376 = 46,848 \text{ cm}^3$.

2. Use what you know about prisms.

$$V_{prism} = B \cdot h$$

$$V_{prism} = (4 \cdot 4) \cdot 5$$

$$V_{prism} = 80 \text{ in}^3$$

3. Use what you know about pyramids.

$$V_{pyramid} = \frac{1}{3} B \cdot h$$

$$V_{pyramid} = \frac{1}{3} (4 \cdot 4) (6)$$

$$V_{pyramid} = 32 \text{ in}^3$$

Now find the total volume by finding the sum of the volumes of each solid.

$$V_{total} = V_{prism} + V_{pyramid}$$

$$V_{total} = 112 \text{ in}^3$$

Practice

Find the volume of the composite solids below. Round your answers to the nearest hundredth.

1. The bases are squares. Find the volume of the green part.

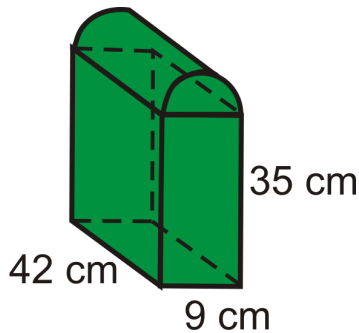
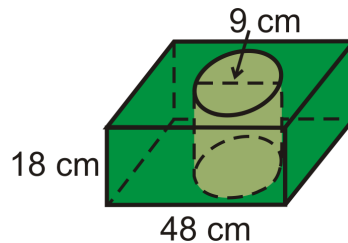

3. A cylinder fits tightly inside a rectangular prism with dimensions in the ratio 5:5:7 and volume 1400 in^3 . Find the volume of the space inside the prism that is not contained in the cylinder.

Find the surface area and volume of the following shapes. Leave your answers in terms of π .

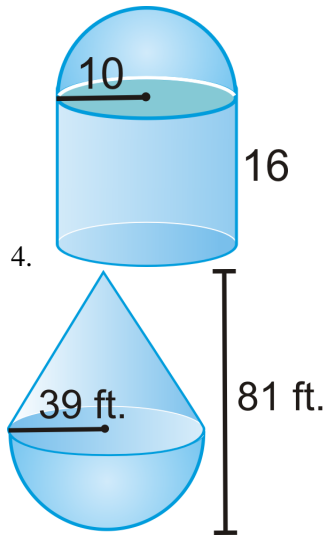

6. You may assume the bottom is *open*.

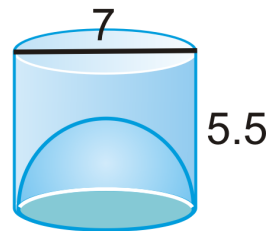

7. A sphere has a radius of 5 cm. A right cylinder has the same radius and volume. Find the height and total surface area of the cylinder.

Tennis balls with a 3 inch diameter are sold in cans of three. The can is a cylinder. Assume the balls touch the can on the sides, top and bottom.



8. What is the volume of one tennis ball?

9. What is the volume of the space *not* occupied by the tennis balls? Round your answer to the nearest hundredth.

One hot day at a fair you buy yourself a snow cone. The height of the cone shaped container is 5 in and its radius is 2 in. The shaved ice is perfectly rounded on top forming a hemisphere.

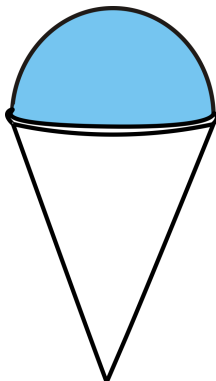

10. What is the volume of the ice in your frozen treat?
11. If the ice melts at a rate of 2 in^3 per minute, how long do you have to eat your treat before it all melts? Give your answer to the nearest minute.

Find the volume of the composite solids. Round your answer to the nearest hundredth.

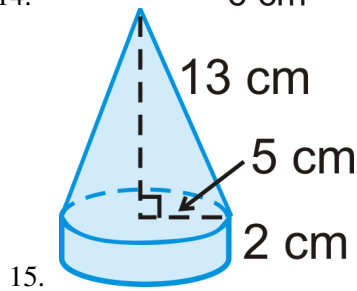
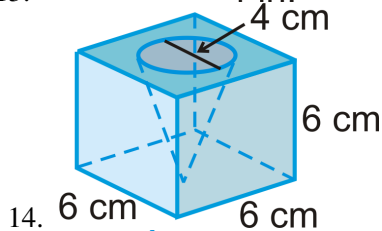
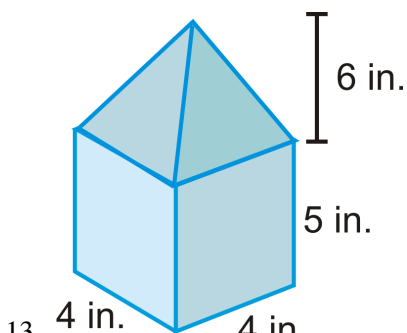

11.9 Area and Volume of Similar Solids

Here you'll learn how to use the ratios between similar solids to solve problems.

What if you had to compare your parents' cylindrical coffee mugs with different dimensions, pictured below? Are the mugs similar? (You may ignore the handles.) If the mugs are similar, find the volume of each, the scale factor and the ratio of the volumes. After completing this Concept, you'll be able to solve problems like these.

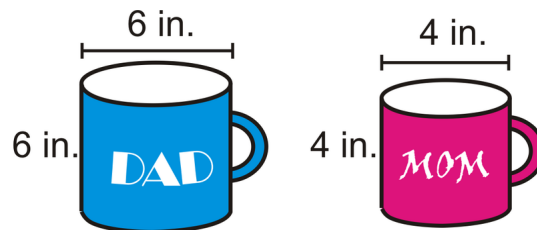

Watch This



MEDIA

Click image to the left for more content.

[CK-12 Foundation: Chapter 11 Area and Volume of Similar Solids A](#)

Learn more about similarity and volume ratios by watching the video at this link.

Guidance

Two solids are **similar** if and only if they are the same type of solid and their corresponding linear measures (radii, heights, base lengths, etc.) are proportional.

Surface Area

Recall that when two shapes are similar, the ratio of the area is a square of the scale factor.

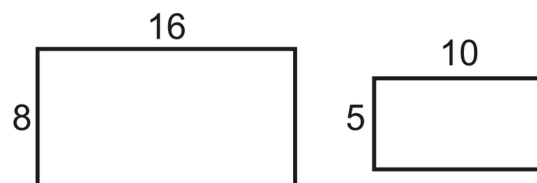

For example, the two rectangles above are similar because their sides are in a ratio of 5:8. The area of the larger rectangle is $8(16) = 128 \text{ units}^2$ and the area of the smaller rectangle is $5(10) = 50 \text{ units}^2$. If we compare the areas in a ratio, it is $50 : 128 = 25 : 64 = 5^2 : 8^2$.

Surface Area Ratio: If two solids are similar with a scale factor of $\frac{a}{b}$, then the surface areas are in a ratio of $\left(\frac{a}{b}\right)^2$.

Volume

Let's look at what we know about similar solids so far.

TABLE 11.2:

| | <i>Ratios</i> | <i>Units</i> |
|-----------------------------------|------------------------------|--------------------------------|
| <i>Scale Factor</i> | $\frac{a}{b}$ | in, ft, cm, m, etc. |
| <i>Ratio of the Surface Areas</i> | $\left(\frac{a}{b}\right)^2$ | in^2, ft^2, cm^2, m^2 , etc. |
| <i>Ratio of the Volumes</i> | ?? | in^3, ft^3, cm^3, m^3 , etc. |

It looks as though there is a pattern. If the ratio of the volumes follows the pattern from above, it should be the cube of the scale factor.

Volume Ratio: If two solids are similar with a scale factor of $\frac{a}{b}$, then the volumes are in a ratio of $\left(\frac{a}{b}\right)^3$.

Example A

Are the two rectangular prisms similar? How do you know?

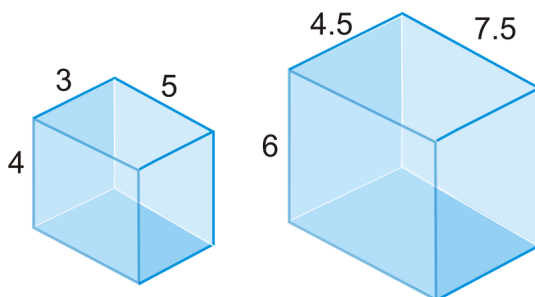

Match up the corresponding heights, widths, and lengths to see if the rectangular prisms are proportional.

$$\frac{\text{small prism}}{\text{large prism}} = \frac{3}{4.5} = \frac{4}{6} = \frac{5}{7.5}$$

The congruent ratios tell us the two prisms are similar.

Example B

Two similar cylinders are below. If the ratio of the areas is 16:25, what is the height of the taller cylinder?

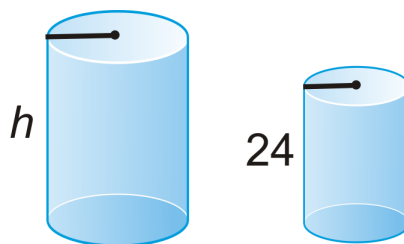

First, we need to take the square root of the area ratio to find the scale factor, $\sqrt{\frac{16}{25}} = \frac{4}{5}$. Now we can set up a proportion to find h .

$$\frac{4}{5} = \frac{24}{h}$$

$$4h = 120$$

$$h = 30$$

Example C

Two spheres have radii in a ratio of 3:4. What is the ratio of their volumes?

If we cube 3 and 4, we will have the ratio of the volumes. Therefore, $3^3 : 4^3$ or 27:64 is the ratio of the volumes.

Watch this video for help with the Examples above.

**MEDIA**

Click image to the left for more content.

[CK-12 Foundation: Chapter 11 Area and Volume of Similar Solids B](#)

Concept Problem Revisited

The coffee mugs are similar because the heights and radii are in a ratio of 2:3, which is also their scale factor. The volume of Dad's mug is $54\pi \text{ in}^3$ and Mom's mug is $16\pi \text{ in}^3$. The ratio of the volumes is $54\pi : 16\pi$, which reduces to 8:27.

Vocabulary

Two solids are *similar* if they are the same type of solid and their corresponding radii, heights, base lengths, widths, etc. are proportional.

Guided Practice

- Determine if the two triangular pyramids similar.

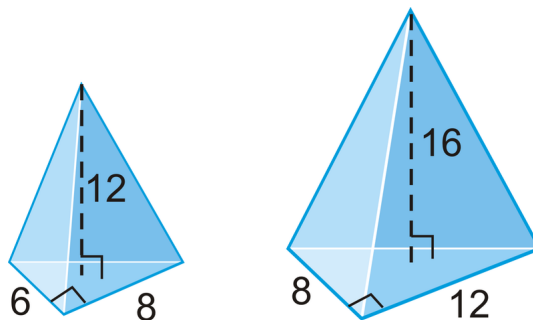

- If the ratio of the volumes of two similar prisms is 125:8, what is their scale factor?
- Two similar right triangle prisms are below. If the ratio of the volumes is 343:125, find the missing sides in both figures.

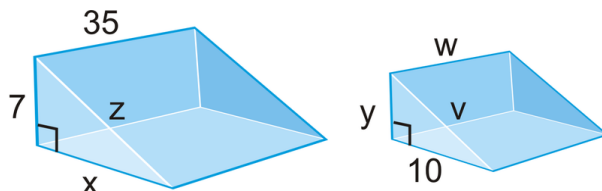

4. The ratio of the surface areas of two similar cylinders is 16:81. If the volume of the smaller cylinder is $96\pi \text{ in}^3$, what is the volume of the larger cylinder?

Answers:

1. Let's match up the corresponding parts.

$$\frac{6}{8} = \frac{12}{16} = \frac{3}{4} \text{ however, } \frac{8}{12} = \frac{2}{3}.$$

Because one of the base lengths is not in the same proportion as the other two lengths, these right triangle pyramids are not similar.

2. We need to take the cubed root of 125 and 8 to find the scale factor.

$$\sqrt[3]{125} : \sqrt[3]{8} = 5 : 2$$

3. If the ratio of the volumes is 343:125, then the scale factor is 7:5, the cubed root of each. With the scale factor, we can now set up several proportions.

$$\begin{array}{cccccc} \frac{7}{5} = \frac{7}{y} & \frac{7}{5} = \frac{x}{10} & \frac{7}{5} = \frac{35}{w} & 7^2 + x^2 = z^2 & \frac{7}{5} = \frac{z}{v} \\ y = 5 & x = 14 & w = 25 & 7^2 + 14^2 = z^2 & \\ & & & z = \sqrt{245} = 7\sqrt{5} & \frac{7}{5} = \frac{7\sqrt{5}}{v} \rightarrow v = 5\sqrt{5} \end{array}$$

4. First we need to find the scale factor from the ratio of the surface areas. If we take the square root of both numbers, we have that the ratio is 4:9. Now, we need cube this to find the ratio of the volumes, $4^3 : 9^3 = 64 : 729$. At this point we can set up a proportion to solve for the volume of the larger cylinder.

$$\begin{aligned} \frac{64}{729} &= \frac{96\pi}{V} \\ 64V &= 69984\pi \\ V &= 1093.5\pi \text{ in}^3 \end{aligned}$$

Practice

Determine if each pair of right solids are similar. *Explain* your reasoning.

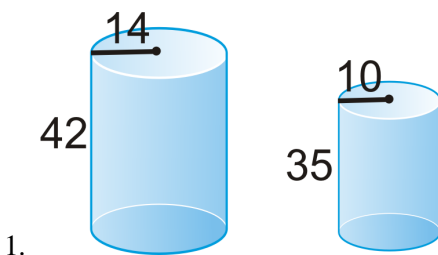

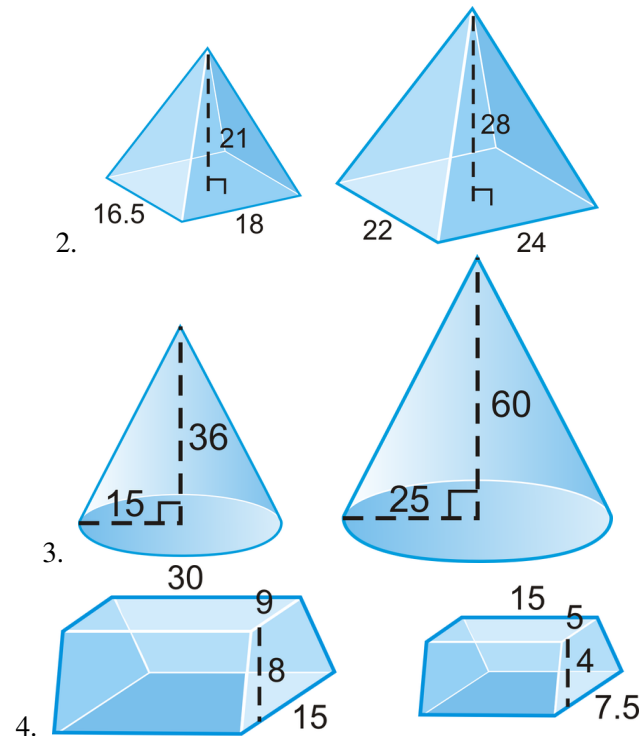

- Are all cubes similar? Why or why not?
- Two prisms have a scale factor of 1:4. What is the ratio of their surface areas?
- Two pyramids have a scale factor of 2:7. What is the ratio of their volumes?
- Two spheres have radii of 5 and 9. What is the ratio of their volumes?
- The surface area of two similar cones is in a ratio of 64:121. What is the scale factor?
- The volume of two hemispheres is in a ratio of 125:1728. What is the scale factor?
- A cone has a volume of 15π and is similar to another larger cone. If the scale factor is 5:9, what is the volume of the larger cone?
- A cube has sides of length x and is enlarged so that the sides are $4x$. How does the volume change?
- The ratio of the volumes of two similar pyramids is 8:27. What is the ratio of their total surface areas?
- The ratio of the volumes of two tetrahedrons is 1000:1. The smaller tetrahedron has a side of length 6 cm. What is the side length of the larger tetrahedron?
- The ratio of the surface areas of two cubes is 64:225. If the volume of the smaller cube is $13824 m^3$, what is the volume of the larger cube?

Below are two similar square pyramids with a volume ratio of 8:27. The base lengths are equal to the heights. Use this to answer questions 16-21.

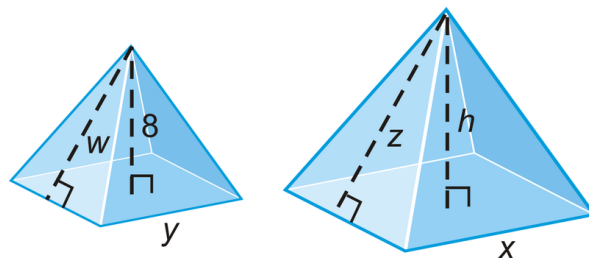

- What is the scale factor?
- What is the ratio of the surface areas?
- Find h, x and y .
- Find w and z .

20. Find the volume of both pyramids.
21. Find the *lateral* surface area of both pyramids.

Animal A and animal B are similar (meaning the size and shape of their bones and bodies are similar) and *the strength of their respective bones are proportional to the cross sectional area of their bones*. Answer the following questions given that the ratio of the height of animal A to the height of animal B is 3:5. You may assume the lengths of their bones are in the same ratio.

22. Find the ratio of the strengths of the bones. How much stronger are the bones in animal B?
23. If their weights are proportional to their volumes, find the ratio of their weights.

Summary

This chapter presents three-dimensional geometric figures beginning with polyhedrons, regular polyhedrons, and an explanation of Euler's Theorem. Three-dimensional figures represented as cross sections and nets are discussed. Then the chapter branches out to the formulas for surface area and volume of prisms, cylinders, pyramids, cones, spheres and composite solids. The relationship between similar solids and their surface areas and volumes are explored.

Chapter Keywords

- Polyhedron
- Face
- Edge
- Vertex
- Prism
- Pyramid
- Euler's Theorem
- Regular Polyhedron
- Regular Tetrahedron
- Cube
- Regular Octahedron
- Regular Dodecahedron
- Regular Icosahedron
- Cross-Section
- Net
- Lateral Face
- Lateral Edge
- Base Edge
- Right Prism
- Oblique Prism
- Surface Area
- Lateral Area
- Surface Area of a Right Prism
- Cylinder
- Surface Area of a Right Cylinder:
- Surface Area of a Regular Pyramid
- Cone

- Slant Height
- Surface Area of a Right Cone
- Volume
- Volume of a Cube Postulate
- Volume Congruence Postulate
- Volume Addition Postulate
- Volume of a Rectangular Prism
- Volume of a Prism
- Cavalieri's Principle
- Volume of a Cylinder
- Volume of a Pyramid
- Volume of a Cone
- Sphere
- Great Circle
- Surface Area of a Sphere
- Volume of a Sphere
- Similar Solids
- Surface Area Ratio
- Volume Ratio

Chapter Review

Match the shape with the correct name.

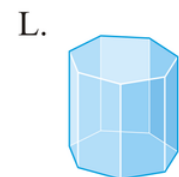
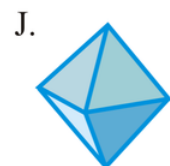
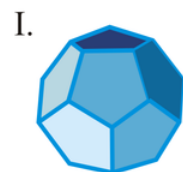
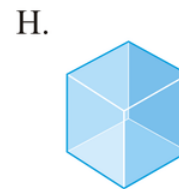
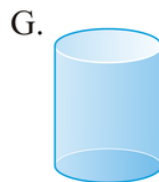
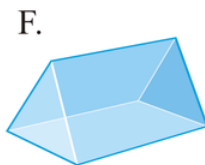
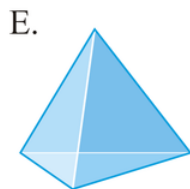
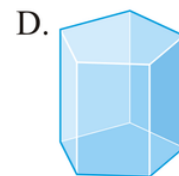
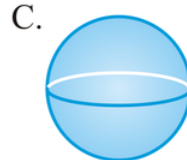
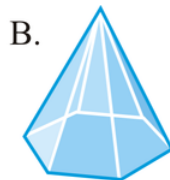

1. Triangular Prism
2. Icosahedron
3. Cylinder
4. Cone
5. Tetrahedron
6. Pentagonal Prism
7. Octahedron
8. Hexagonal Pyramid

9. Octagonal Prism
10. Sphere
11. Cube
12. Dodecahedron

Match the formula with its description.

13. Volume of a Prism - A. $\frac{1}{3}\pi r^2 h$
14. Volume of a Pyramid - B. $\pi r^2 h$
15. Volume of a Cone - C. $4\pi r^2$
16. Volume of a Cylinder - D. $\frac{4}{3}\pi r^3$
17. Volume of a Sphere - E. $\pi r^2 + \pi r l$
18. Surface Area of a Prism - F. $2\pi r^2 + 2\pi r h$
19. Surface Area of a Pyramid - G. $\frac{1}{3}Bh$
20. Surface Area of a Cone - H. Bh
21. Surface Area of a Cylinder - I. $B + \frac{1}{2}Pl$
22. Surface Area of a Sphere - J. The sum of the area of the bases and the area of each rectangular lateral face.

Texas Instruments Resources

In the CK-12 Texas Instruments Geometry FlexBook, there are graphing calculator activities designed to supplement the objectives for some of the lessons in this chapter. See <http://www.ck12.org/flexr/chapter/9696>.

Rigid Transformations

Chapter Outline

- 12.1 REFLECTION SYMMETRY
 - 12.2 ROTATION SYMMETRY
 - 12.3 GEOMETRIC TRANSLATIONS
 - 12.4 ROTATIONS
 - 12.5 REFLECTIONS
 - 12.6 COMPOSITION OF TRANSFORMATIONS
 - 12.7 TESSELLATIONS
-

Introduction

The final chapter of Geometry explores transformations. A transformation is a move, flip, or rotation of an image. First, we will look at different types of symmetry and then discuss the different types of transformations. Finally, we will compose transformations and look at tessellations.

12.1 Reflection Symmetry

Here you'll learn how to determine whether or not a shape has reflection symmetry and how to draw lines of symmetry.

What if you were asked to consider the presence of symmetry in nature? The starfish, below, is one example of symmetry in nature. Draw in the line(s) of symmetry. After completing this Concept, you'll be able to draw lines of symmetry through shapes and objects like this one.



Watch This



MEDIA

Click image to the left for more content.

[CK-12 Foundation: Chapter12ReflectionSymmetryA](#)

Learn more about reflectional symmetry by watching the video at [this link](#).

Guidance

A **line of symmetry** is a line that passes through a figure such that it splits the figure into two congruent halves. Many figures have a line of symmetry, but some do not have any lines of symmetry. Figures can also have more than one line of symmetry. A shape has **reflection symmetry** when it has one or more lines of symmetry.

Example A

Find all lines of symmetry for the shape below.

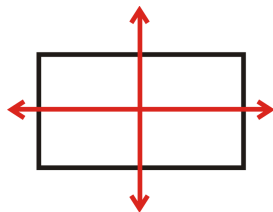

This figure has two lines of symmetry.

**Example B**

Does the figure below have reflection symmetry?



Yes, this figure has reflection symmetry.

**Example C**

Does the figure below have reflection symmetry?



Yes, this figure has reflection symmetry.

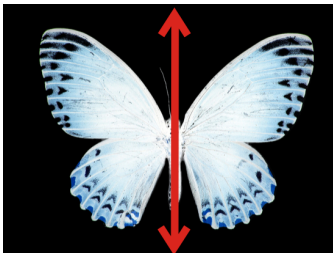

Watch this video for help with the Examples above.



MEDIA

Click image to the left for more content.

[CK-12 Foundation: Chapter12ReflectionSymmetryB](#)

Concept Problem Revisited

The starfish has 5 lines of symmetry.

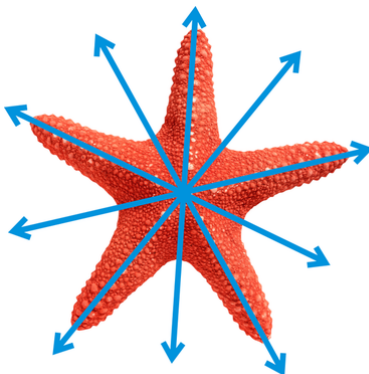

Vocabulary

A *line of symmetry* is a line that passes through a figure such that it splits the figure into two congruent halves. *Reflection symmetry* is present when a figure has one or more lines of symmetry.

Guided Practice

Find all lines of symmetry for the shapes below.

1.

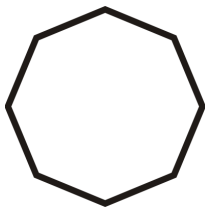

2.



3.

**Answers:**

For each figure, draw lines through the figure so that the lines perfectly cut the figure in half. Figure 1 has eight, 2 has no lines of symmetry, and 3 has one.

1.

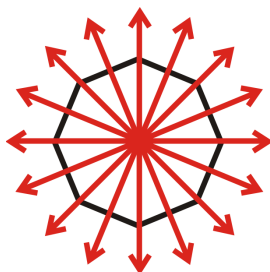

2.



3.

**Practice**

For #1 through #8, determine whether each statement is true or false.

1. All right triangles have line symmetry.

2. All isosceles triangles have line symmetry.
 3. Every rectangle has line symmetry.
 4. Every rectangle has exactly two lines of symmetry.
 5. Every parallelogram has line symmetry.
 6. Every square has exactly two lines of symmetry.
 7. Every regular polygon has three lines of symmetry.
 8. Every sector of a circle has a line of symmetry.
9. What type of shape has an infinite number of lines of symmetry?

Find all lines of symmetry for the letters below.

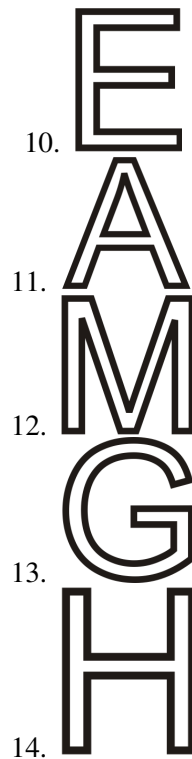

Determine if the words below have reflection symmetry.

15. **OHIO**
16. **MOW**
17. **WOW**
18. **KICK**
19. **pod**

Trace each figure and then draw in all lines of symmetry.





21.

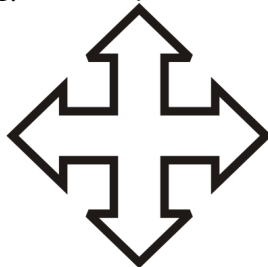

22.

Determine if the figures below have reflection symmetry. Identify all lines of symmetry.

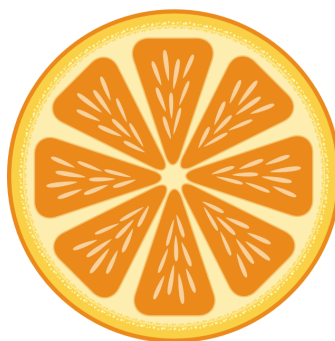

23.



24.

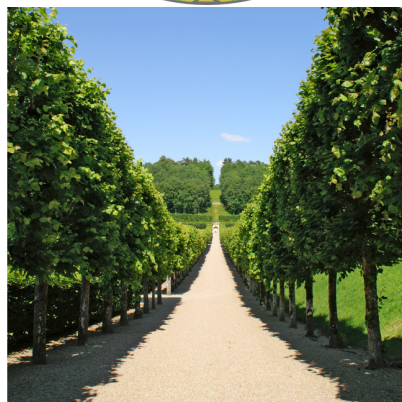

25.

12.2 Rotation Symmetry

Here you'll learn how to determine whether or not a shape has rotation symmetry.

What if you were asked to consider the presence of symmetry in nature? The starfish, below, is one example of symmetry in nature. Draw in the center of symmetry and the angle of rotation for this starfish. After completing this Concept, you'll be able to answer questions like these.



Watch This



MEDIA

Click image to the left for more content.

[CK-12 Foundation: Chapter12RotationSymmetryA](#)

[Learn more about rotational symmetry by watching the video at this link.](#)

Guidance

Rotational Symmetry is when a figure can be rotated (less than 360°) and it looks the same way it did before the rotation. The **center of rotation** is the point at which the figure is rotated around such that the rotational symmetry holds. Typically, the center of rotation is the center of the figure. Along with rotational symmetry and a center of rotation, figures will have an **angle of rotation**, that tells us how many degrees we can rotate a figure so that it still looks the same. In general, if a shape can be rotated n times, the angle of rotation is $\frac{360^\circ}{n}$. Then, multiply the angle of rotation by 1, 2, 3..., and n to find the additional angles of rotation.

Example A

Determine if the figure below has rotational symmetry. Find the angle and how many times it can be rotated.



The pentagon can be rotated 4 times and show rotational symmetry. Because there are 5 lines of rotational symmetry, the angle would be $\frac{360^\circ}{5} = 72^\circ$. Note that the 5th rotation would be 360° and so does not count for demonstrating rotational symmetry.

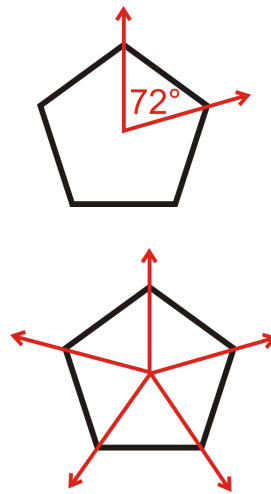

Example B

Determine if the figure below has rotational symmetry. Find the angle and how many times it can be rotated.



The *N* can be rotated once. The angle of rotation is 180° .

Example C

Determine if the figure below has rotational symmetry. Find the angle and how many times it can be rotated.

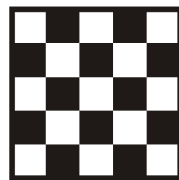

The checkerboard can be rotated 3 times. There are 4 lines of rotational symmetry, so the angle of rotation is $\frac{360^\circ}{4} = 90^\circ$. It can also be rotated 180° and 270° and it will still look the same.

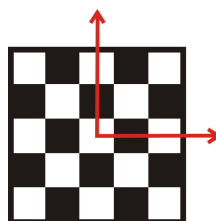

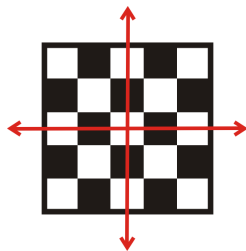

Watch this video for help with the Examples above.



MEDIA

Click image to the left for more content.

[CK-12 Foundation: Chapter12RotationSymmetryB](#)

Concept Problem Revisited

The starfish has rotational symmetry of 72° . Therefore, the starfish can be rotated 72° , 144° , 216° , and 288° and it will still look the same. The center of rotation is the center of the starfish.

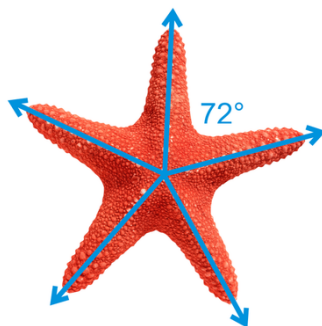

Vocabulary

Rotational symmetry is present when a figure can be rotated (less than 360°) such that it looks like it did before the rotation. The **center of rotation** is the point a figure is rotated around such that the rotational symmetry holds. The **angle of rotation** that tells us how many degrees we can rotate a figure so that it still looks the same. In general, if a shape can be rotated n times, the angle of rotation is $\frac{360^\circ}{n}$.

Guided Practice

Find the angle of rotation and the number of times each figure can rotate.

1.

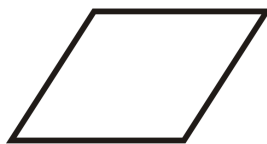

2.

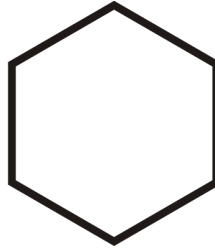

3.

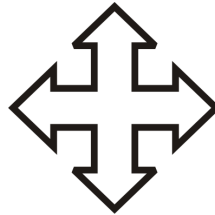
**Answers:**

1. The parallelogram can be rotated twice. The angle of rotation is 180° .
2. The hexagon can be rotated six times. The angle of rotation is 60° .
3. This figure can be rotated four times. The angle of rotation is 90° .

Practice

1. If a figure has 3 lines of rotational symmetry, it can be rotated _____ times.
2. If a figure can be rotated 6 times, it has _____ lines of rotational symmetry.
3. If a figure can be rotated n times, it has _____ lines of rotational symmetry.
4. To find the angle of rotation, divide 360° by the total number of _____.
5. Every square has an angle of rotation of _____.

Determine whether each statement is true or false.

6. Every parallelogram has rotational symmetry.
7. Every figure that has line symmetry also has rotational symmetry.

Determine whether the words below have rotation symmetry.

8. **OHIO**
9. **MOW**
10. **WOW**
11. **KICK**
12. **pod**

Find the angle of rotation and the number of times each figure can rotate.



13.

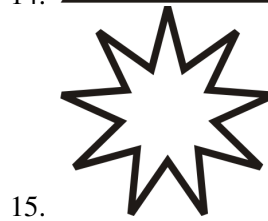
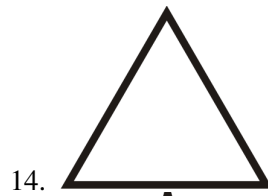

Determine if the figures below have rotation symmetry. Identify the angle of rotation.

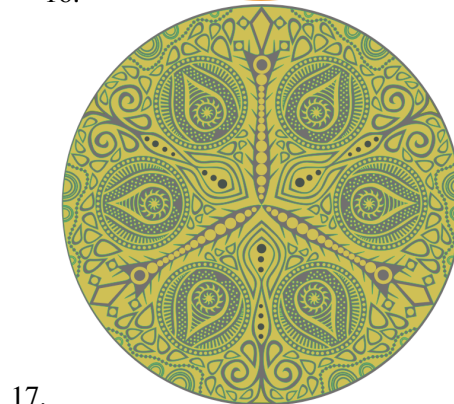
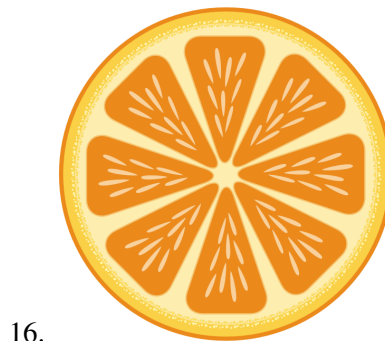

12.3 Geometric Translations

Here you'll learn what a translation is and how to perform translation rules.

What if Lucy lived in San Francisco, S , and her parents lived in Paso Robles, P ? She will be moving to Ukiah, U , in a few weeks. All measurements are in miles. Find:

- The component form of \vec{PS} , \vec{SU} and \vec{PU} .
- Lucy's parents are considering moving to Fresno, F . Find the component form of \vec{PF} and \vec{UF} .
- Is Ukiah or Paso Robles closer to Fresno?

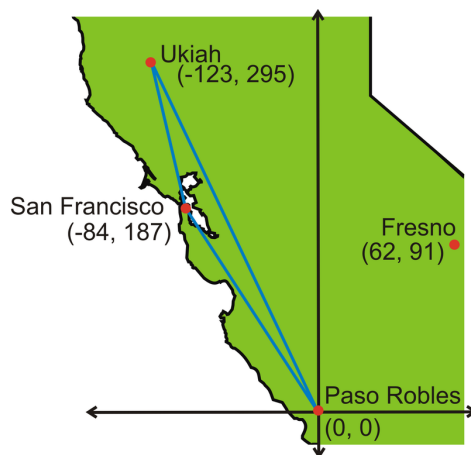

After completing this Concept, you'll be able to answer these questions.

Watch This



MEDIA

Click image to the left for more content.

CK-12 Foundation: Chapter12TranslationsA

Learn more about translations by watching the video at this link.

Guidance

A **transformation** is an operation that moves, flips, or changes a figure to create a new figure. A **rigid transformation** is a transformation that preserves size and shape. The rigid transformations are: translations (discussed here), reflections, and rotations. The new figure created by a transformation is called the **image**. The original figure is called the **preimage**. Another word for a rigid transformation is an **isometry**. Rigid transformations are also called

congruence transformations. If the preimage is A , then the image would be labeled A' , said “a prime.” If there is an image of A' , that would be labeled A'' , said “a double prime.”

A **translation** is a transformation that moves every point in a figure the same distance in the same direction. In the coordinate plane, we say that a translation moves a figure x units and y units. Another way to write a translation rule is to use vectors. A **vector** is a quantity that has direction and size.

In the graph below, the line from A to B , or the distance traveled, is the vector. This vector would be labeled \vec{AB} because A is the **initial point** and B is the **terminal point**. The terminal point always has the arrow pointing towards it and has the half-arrow over it in the label.

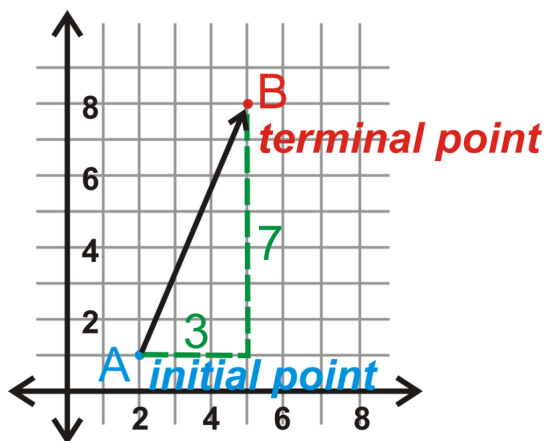

The **component form** of \vec{AB} combines the horizontal distance traveled and the vertical distance traveled. We write the component form of \vec{AB} as $\langle 3, 7 \rangle$ because \vec{AB} travels 3 units to the right and 7 units up. Notice the brackets are pointed, $\langle 3, 7 \rangle$, not curved.

Example A

Graph square $S(1, 2), Q(4, 1), R(5, 4)$ and $E(2, 5)$. Find the image after the translation $(x, y) \rightarrow (x - 2, y + 3)$. Then, graph and label the image.

The translation notation tells us that we are going to move the square to the left 2 and up 3.

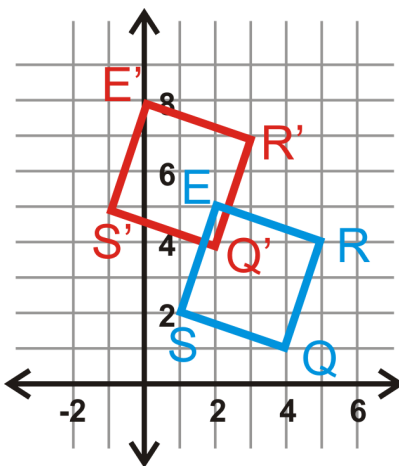

$$\begin{aligned}(x,y) &\rightarrow (x-2,y+3) \\ S(1,2) &\rightarrow S'(-1,5) \\ Q(4,1) &\rightarrow Q'(2,4) \\ R(5,4) &\rightarrow R'(3,7) \\ E(2,5) &\rightarrow E'(0,8)\end{aligned}$$

Example B

Name the vector and write its component form.

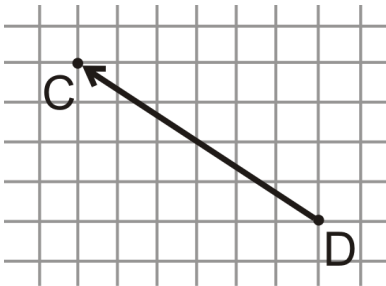

The vector is \vec{DC} . From the initial point D to terminal point C , you would move 6 units to the left and 4 units up. The component form of \vec{DC} is $\langle -6, 4 \rangle$.

Example C

Name the vector and write its component form.

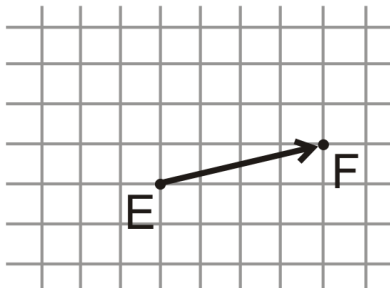

The vector is \vec{EF} . The component form of \vec{EF} is $\langle 4, 1 \rangle$.

Watch this video for help with the Examples above.



MEDIA

Click image to the left for more content.

Concept Problem Revisited

a) $\vec{PS} = \langle -84, 187 \rangle$, $\vec{SU} = \langle -39, 108 \rangle$, $\vec{PU} = \langle -123, 295 \rangle$

b) $\vec{PF} = \langle 62, 91 \rangle$, $\vec{UF} = \langle 185, -204 \rangle$

c) You can plug the vector components into the Pythagorean Theorem to find the distances. Paso Robles is closer to Fresno than Ukiah.

$$UF = \sqrt{185^2 + (-204)^2} \cong 275.4 \text{ miles}, PF = \sqrt{62^2 + 91^2} \cong 110.1 \text{ miles}$$

Vocabulary

A **transformation** is an operation that moves, flips, or otherwise changes a figure to create a new figure. A **rigid transformation** (also known as an **isometry** or **congruence transformation**) is a transformation that does not change the size or shape of a figure. The new figure created by a transformation is called the **image**. The original figure is called the **preimage**. A **translation** is a transformation that moves every point in a figure the same distance in the same direction. A **vector** is a quantity that has direction and size. The **component form** of a vector combines the horizontal distance traveled and the vertical distance traveled.

Guided Practice

- Find the translation rule for $\triangle TRI$ to $\triangle T'R'I'$.
- Draw the vector \vec{ST} with component form $\langle 2, -5 \rangle$.

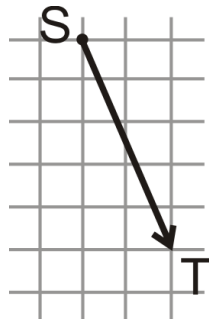

- Triangle $\triangle ABC$ has coordinates $A(3, -1)$, $B(7, -5)$ and $C(-2, -2)$. Translate $\triangle ABC$ using the vector $\langle -4, 5 \rangle$. Determine the coordinates of $\triangle A'B'C'$.

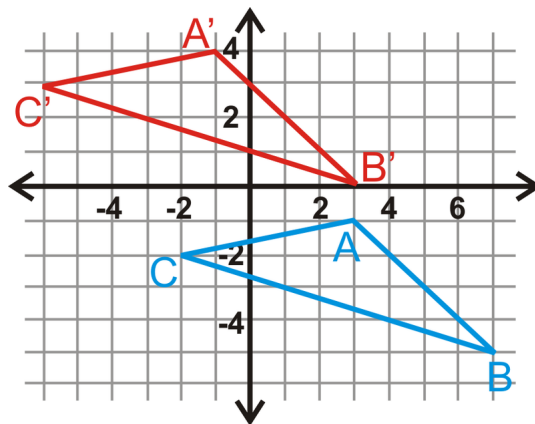

4. Write the translation rule for the vector translation from #3.

Answers:

1. Look at the movement from T to T' . T is $(-3, 3)$ and T' is $(3, -1)$. The change in x is 6 units to the right and the change in y is 4 units down. Therefore, the translation rule is $(x, y) \rightarrow (x + 6, y - 4)$.

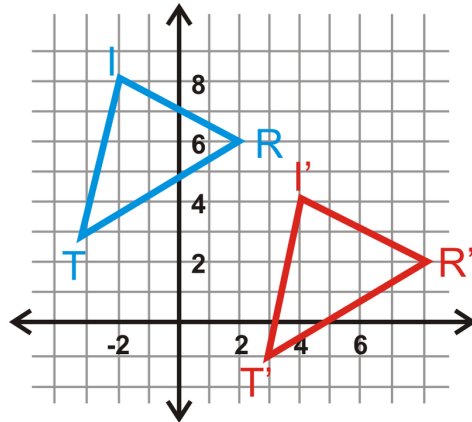

2. The graph is the vector \vec{ST} . From the initial point S it moves down 5 units and to the right 2 units.

3. It would be helpful to graph $\triangle ABC$. To translate $\triangle ABC$, add each component of the vector to each point to find $\triangle A'B'C'$.

$$\begin{aligned} A(3, -1) + \langle -4, 5 \rangle &= A'(-1, 4) \\ B(7, -5) + \langle -4, 5 \rangle &= B'(3, 0) \\ C(-2, -2) + \langle -4, 5 \rangle &= C'(-6, 3) \end{aligned}$$

4. To write $\langle -4, 5 \rangle$ as a translation rule, it would be $(x, y) \rightarrow (x - 4, y + 5)$.

Practice

1. What is the difference between a vector and a ray?

Use the translation $(x, y) \rightarrow (x + 5, y - 9)$ for questions 2-8.

2. What is the image of $A(-6, 3)$?
3. What is the image of $B(4, 8)$?
4. What is the preimage of $C'(5, -3)$?
5. What is the image of A' ?
6. What is the preimage of $D'(12, 7)$?
7. What is the image of A'' ?
8. Plot A, A', A'' , and A''' from the questions above. What do you notice? Write a conjecture.

The vertices of $\triangle ABC$ are $A(-6, -7)$, $B(-3, -10)$ and $C(-5, 2)$. Find the vertices of $\triangle A'B'C'$, given the translation rules below.

9. $(x, y) \rightarrow (x - 2, y - 7)$
10. $(x, y) \rightarrow (x + 11, y + 4)$

11. $(x, y) \rightarrow (x, y - 3)$
12. $(x, y) \rightarrow (x - 5, y + 8)$

In questions 13-16, $\triangle A'B'C'$ is the image of $\triangle ABC$. Write the translation rule.

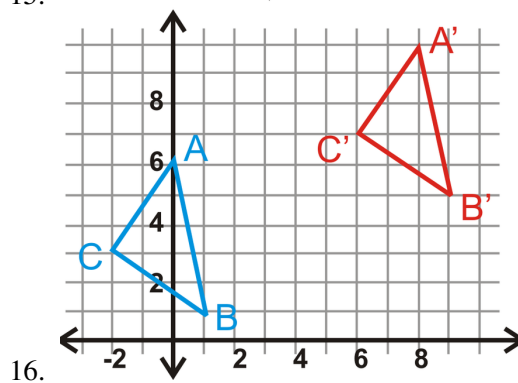
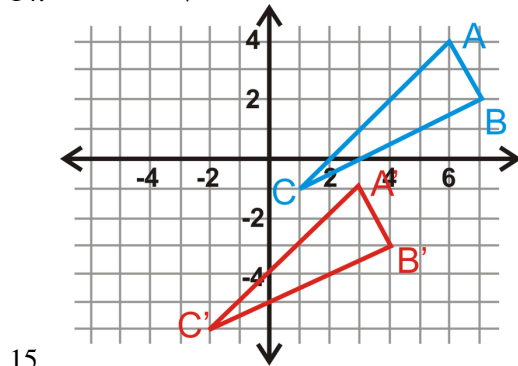
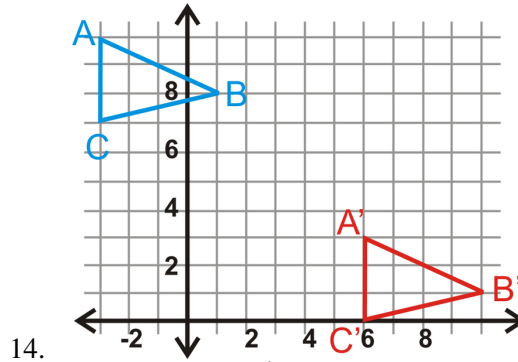
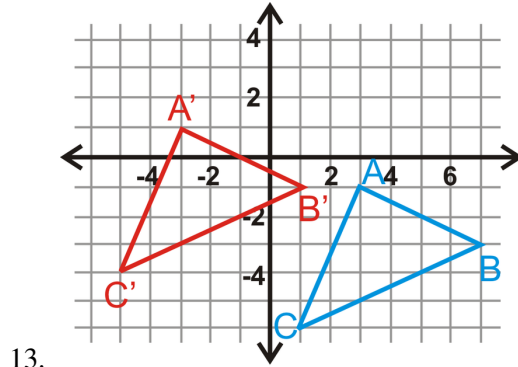

For questions 17-19, name each vector and find its component form.

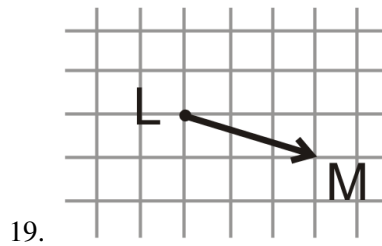
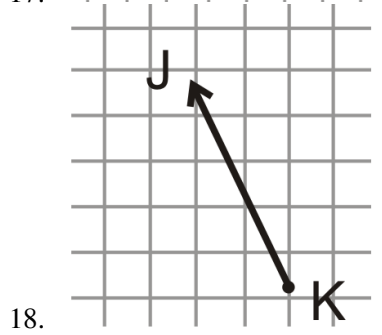
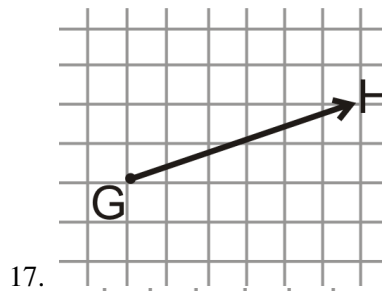

20. The coordinates of $\triangle DEF$ are $D(4, -2)$, $E(7, -4)$ and $F(5, 3)$. Translate $\triangle DEF$ using the vector $\langle 5, 11 \rangle$ and find the coordinates of $\triangle D'E'F'$.
21. The coordinates of quadrilateral $QUAD$ are $Q(-6, 1)$, $U(-3, 7)$, $A(4, -2)$ and $D(1, -8)$. Translate $QUAD$ using the vector $\langle -3, -7 \rangle$ and find the coordinates of $Q'U'A'D'$.

12.4 Rotations

Here you'll learn what a rotation is and how to find the coordinates of a rotated figure.

What if you wanted to find the center of rotation and angle of rotation for the arrows in the international recycling symbol below? It is three arrows rotated around a point. Let's assume that the arrow on the top is the preimage and the other two are its images. Find the center of rotation and the angle of rotation for each image. After completing this Concept, you'll be able to answer these questions.

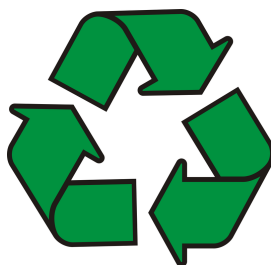

Watch This



MEDIA

Click image to the left for more content.

[CK-12 Foundation: Chapter12RotationsA](#)

See also this video: [Brightstorm:Rotations](#)

Guidance

A **transformation** is an operation that moves, flips, or changes a figure to create a new figure. A **rigid transformation** is a transformation that preserves size and shape. The rigid transformations are: translations, reflections, and rotations (discussed here). The new figure created by a transformation is called the **image**. The original figure is called the **preimage**. Another word for a rigid transformation is an **isometry**. Rigid transformations are also called **congruence transformations**. If the preimage is A , then the image would be labeled A' , said "a prime." If there is an image of A' , that would be labeled A'' , said "a double prime."

A **rotation** is a transformation by which a figure is turned around a fixed point to create an image. The **center of rotation** is the fixed point that a figure is rotated around. Lines can be drawn from the preimage to the center of rotation, and from the center of rotation to the image. The angle formed by these lines is the **angle of rotation**.

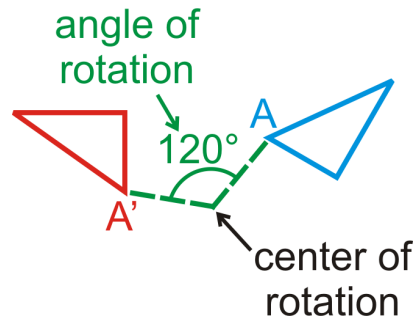

In this Concept, our center of rotation will always be the **origin**. Rotations can also be clockwise or counterclockwise. We will only do **counterclockwise** rotations, to go along with the way the quadrants are numbered.

Investigation: Drawing a Rotation of 100°

Tools Needed: pencil, paper, protractor, ruler

1. Draw $\triangle ABC$ and a point R outside the circle.

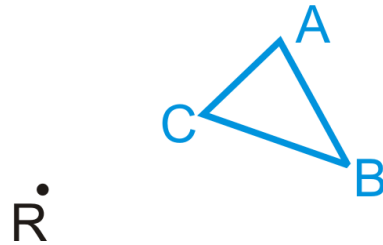

2. Draw the line segment \overline{RB} .

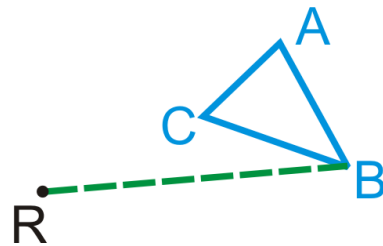

3. Take your protractor, place the center on R and the initial side on \overline{RB} . Mark a 100° angle.

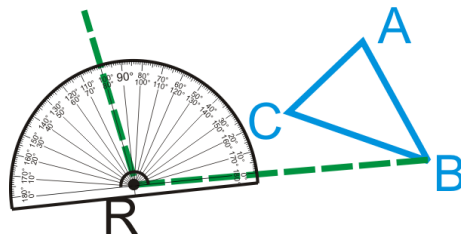

4. Find B' such that $RB = RB'$.
5. Repeat steps 2-4 with points A and C .
6. Connect A' , B' , and C' to form $\triangle A'B'C'$.

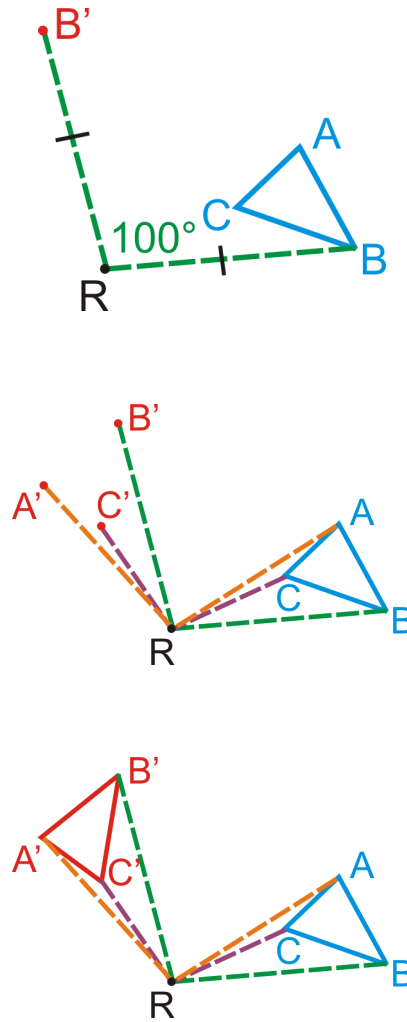

This is the process you would follow to rotate any figure 100° counterclockwise. If it was a different angle measure, then in Step 3, you would mark a different angle. You will need to repeat steps 2-4 for every vertex of the shape.

Common Rotations

- **Rotation of 180° :** If (x,y) is rotated 180° around the origin, then the image will be $(-x, -y)$.
- **Rotation of 90° :** If (x,y) is rotated 90° around the origin, then the image will be $(-y,x)$.
- **Rotation of 270° :** If (x,y) is rotated 270° around the origin, then the image will be $(y, -x)$.

While we can rotate any image any amount of degrees, only 90° , 180° and 270° have special rules. To rotate a figure by an angle measure other than these three, you must use the process from the Investigation.

Example A

Rotate $\triangle ABC$, with vertices $A(7,4)$, $B(6,1)$, and $C(3,1)$ 180° . Find the coordinates of $\triangle A'B'C'$.

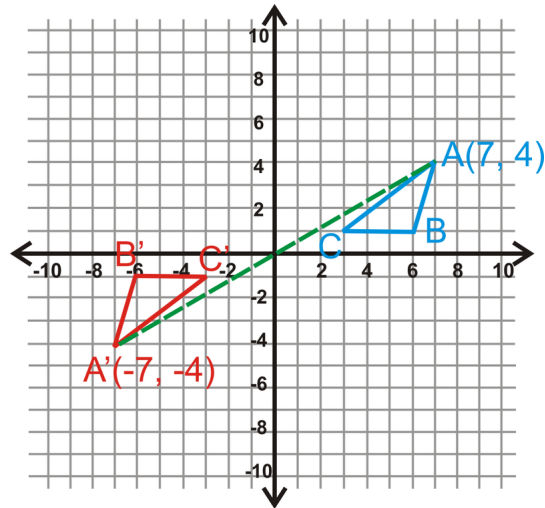

It is very helpful to graph the triangle. If A is $(7, 4)$, that means it is 7 units to the right of the origin and 4 units up. A' would then be 7 units to the *left* of the origin and 4 units *down*. The vertices are:

$$A(7, 4) \rightarrow A'(-7, -4)$$

$$B(6, 1) \rightarrow B'(-6, -1)$$

$$C(3, 1) \rightarrow C'(-3, -1)$$

Example B

Rotate \overline{ST} 90° counter-clockwise about the origin.

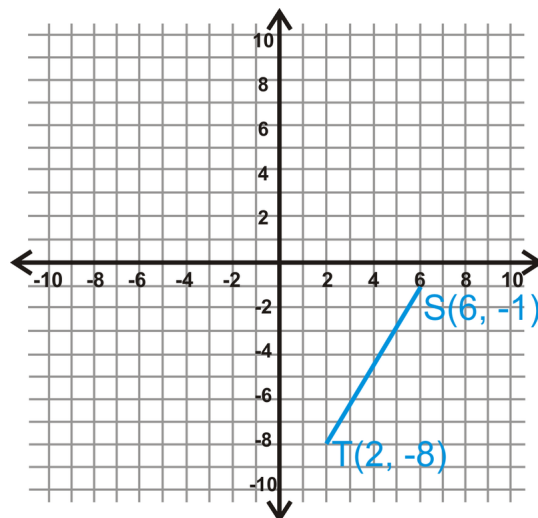

Using the 90° rotation rule, T' is $(8, 2)$.

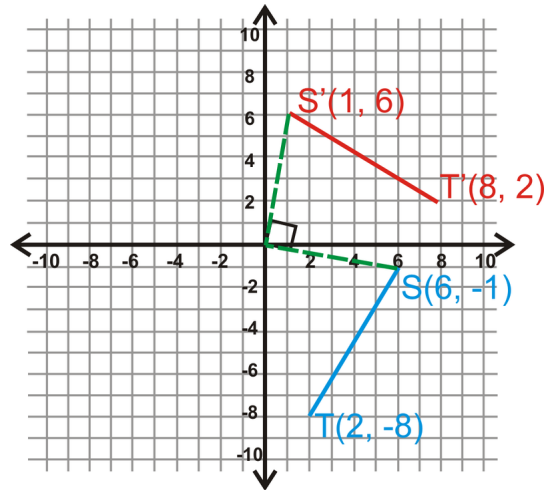

Example C

Find the coordinates of $ABCD$ after a 270° rotation counter-clockwise about the origin.

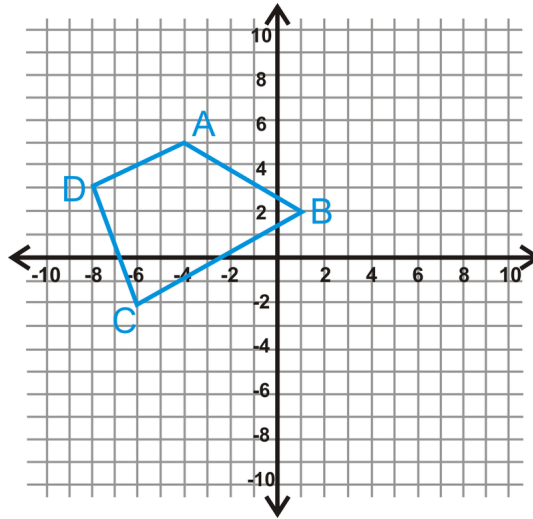

Using the rule, we have:

$$\begin{aligned} (x, y) &\rightarrow (y, -x) \\ A(-4, 5) &\rightarrow A'(5, 4) \\ B(1, 2) &\rightarrow B'(2, -1) \\ C(-6, -2) &\rightarrow C'(-2, 6) \\ D(-8, 3) &\rightarrow D'(3, 8) \end{aligned}$$

Watch this video for help with the Examples above.



MEDIA

Click image to the left for more content.

CK-12 Foundation: Chapter12RotationsB

Concept Problem Revisited

The center of rotation is shown in the picture below. If we draw rays to the same point in each arrow, we see that the two images are a 120° rotation in either direction.

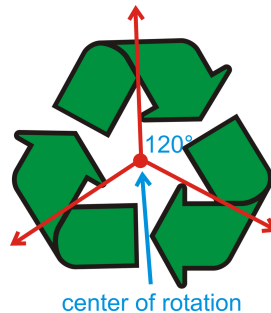
**Vocabulary**

A **transformation** is an operation that moves, flips, or otherwise changes a figure to create a new figure. A **rigid transformation** (also known as an **isometry** or **congruence transformation**) is a transformation that does not change the size or shape of a figure. The new figure created by a transformation is called the **image**. The original figure is called the **preimage**. A **rotation** is a transformation where a figure is turned around a fixed point to create an image. The lines drawn from the preimage to the **center of rotation** and from the center of rotation to the image form the **angle of rotation**.

Guided Practice

1. The rotation of a quadrilateral is shown below. What is the measure of x and y ?
2. A rotation of 80° clockwise is the same as what counterclockwise rotation?
3. A rotation of 160° counterclockwise is the same as what clockwise rotation?

Answers:

1. Because a rotation is an isometry that produces congruent figures, we can set up two equations to solve for x and y .

$$\begin{aligned} 2y &= 80^\circ \\ y &= 40^\circ \end{aligned}$$

$$\begin{aligned} 2x - 3 &= 15 \\ 2x &= 18 \\ x &= 9 \end{aligned}$$

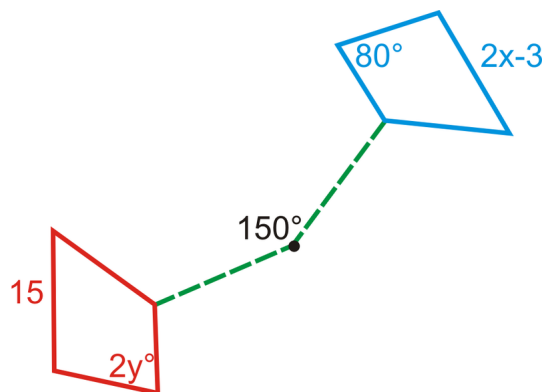

2. There are 360° around a point. So, an 80° rotation clockwise is the same as a $360^\circ - 80^\circ = 280^\circ$ rotation counterclockwise.

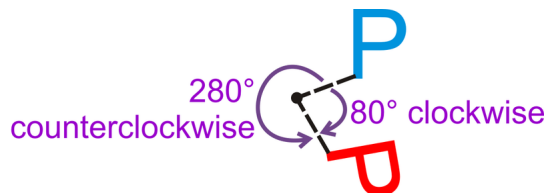

3. $360^\circ - 160^\circ = 200^\circ$ clockwise rotation.

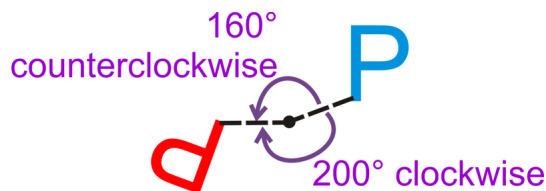

Practice

In the questions below, every rotation is *counterclockwise*, unless otherwise stated.

1. If you rotated the letter p 180° counterclockwise, what letter would you have?
2. If you rotated the letter p 180° clockwise, what letter would you have? Why do you think that is?
3. A 90° clockwise rotation is the same as what counterclockwise rotation?
4. A 270° clockwise rotation is the same as what counterclockwise rotation?
5. Rotating a figure 360° is the same as what other rotation?

Rotate each figure in the coordinate plane the given angle measure. The center of rotation is the origin.

6. 180°

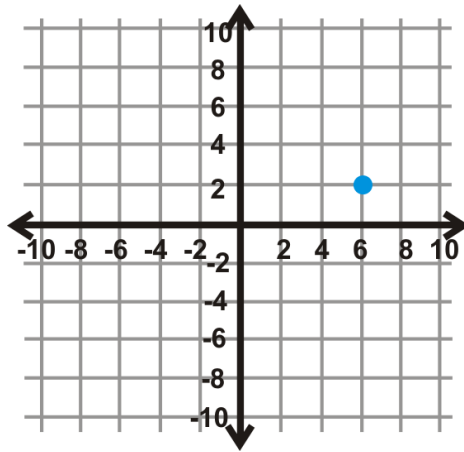
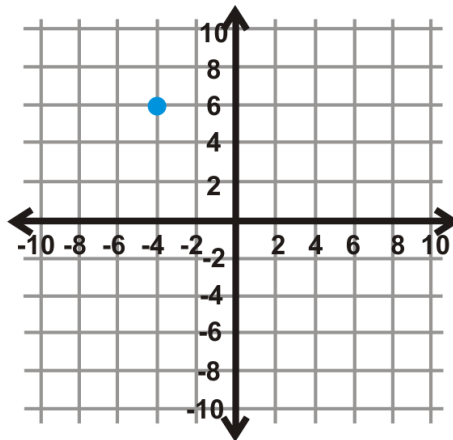
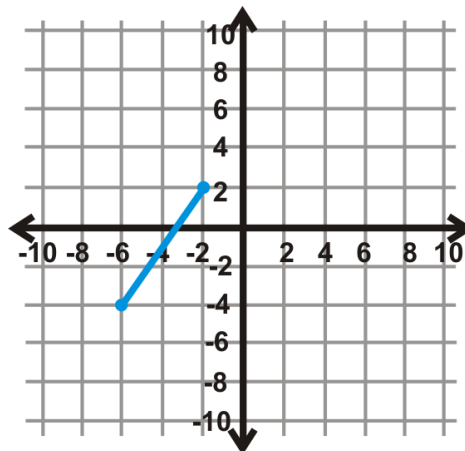
7. 90° 8. 180° 9. 270°

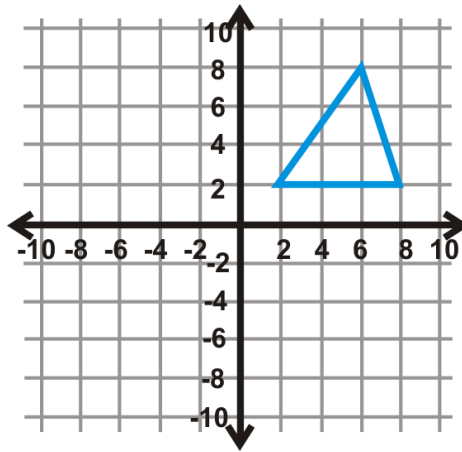

10. 90°

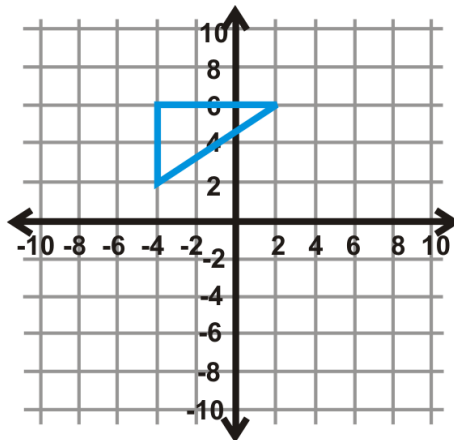

11. 270°

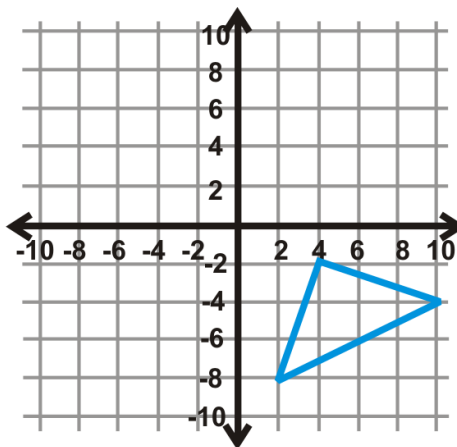

12. 180°

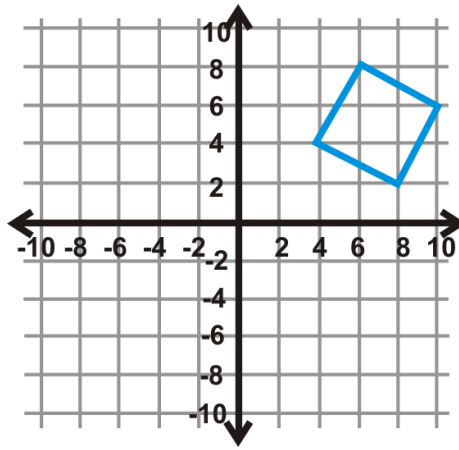

13. 270°

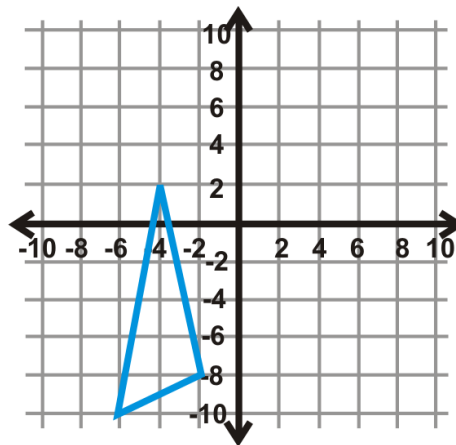

14. 90°

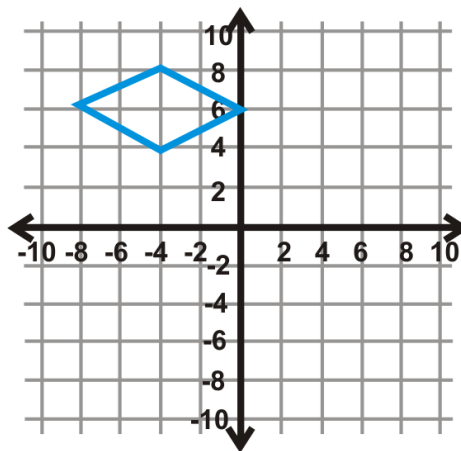

Algebra Connection Find the measure of x in the rotations below. The blue figure is the preimage.

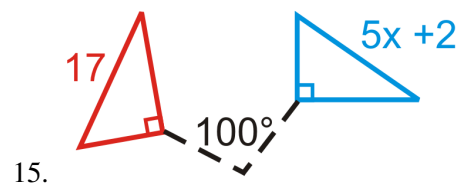

15.

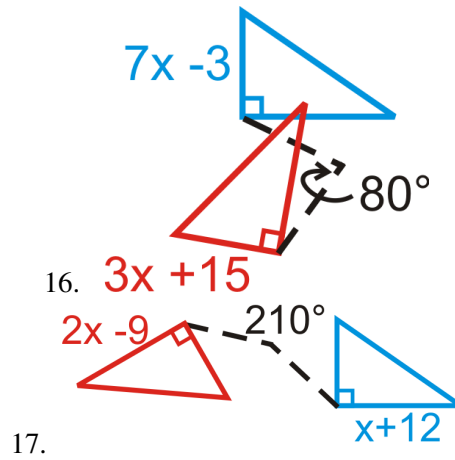

Find the angle of rotation for the graphs below. The center of rotation is the origin and the blue figure is the preimage.

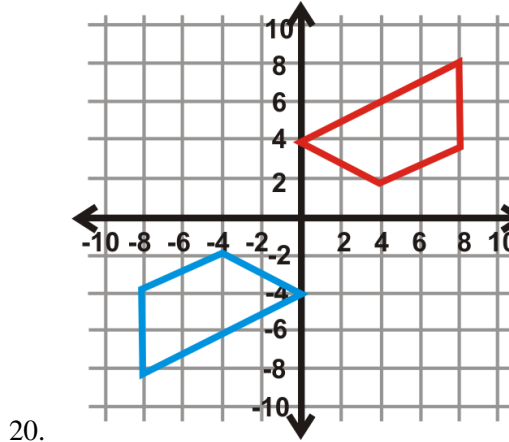
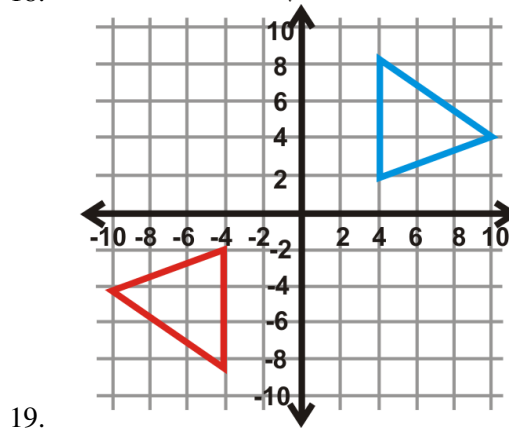
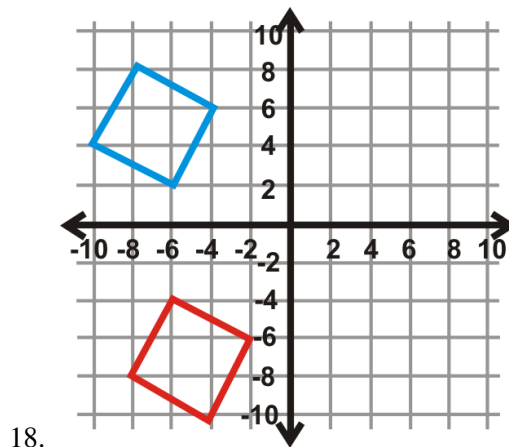

12.5 Reflections

Here you'll learn what a reflection is and how to find the coordinates of a reflected figure.

What if you noticed that a lake can act like a mirror in nature? Describe the line of reflection in the photo below. If this image were on the coordinate plane, what could the equation of the line of reflection be? (There could be more than one correct answer, depending on where you place the origin.) After completing this Concept, you'll be able to answer this question.



Watch This



MEDIA

Click image to the left for more content.

[CK-12 Foundation: Chapter12ReflectionsA](#)

Watch more about transformations and isometries by watching the last part of this video.

Guidance

A **transformation** is an operation that moves, flips, or changes a figure to create a new figure. A **rigid transformation** is a transformation that preserves size and shape. The rigid transformations are: translations, reflections (discussed here), and rotations. The new figure created by a transformation is called the **image**. The original figure is called the **preimage**. Another word for a rigid transformation is an **isometry**. Rigid transformations are also called **congruence transformations**. If the preimage is A , then the image would be labeled A' , said "a prime." If there is an image of A' , that would be labeled A'' , said "a double prime."

A **reflection** is a transformation that turns a figure into its mirror image by flipping it over a line. Another way to describe a reflection is a "flip." The **line of reflection** is the line that a figure is reflected over. If a point is on the line of reflection then the image is the same as the original point.

Common Reflections

- **Reflection over the y -axis:** If (x, y) is reflected over the y -axis, then the image is $(-x, y)$.

- **Reflection over the x -axis:** If (x, y) is reflected over the x -axis, then the image is $(x, -y)$.
- **Reflection over $x = a$:** If (x, y) is reflected over the vertical line $x = a$, then the image is $(2a - x, y)$.
- **Reflection over $y = b$:** If (x, y) is reflected over the horizontal line $y = b$, then the image is $(x, 2b - y)$.
- **Reflection over $y = x$:** If (x, y) is reflected over the line $y = x$, then the image is (y, x) .
- **Reflection over $y = -x$:** If (x, y) is reflected over the line $y = -x$, then the image is $(-y, -x)$.

Example A

Reflect the letter " F " over the x -axis.

To reflect the letter F over the x -axis, now the x -coordinates will remain the same and the y -coordinates will be the same distance away from the x -axis on the other side.

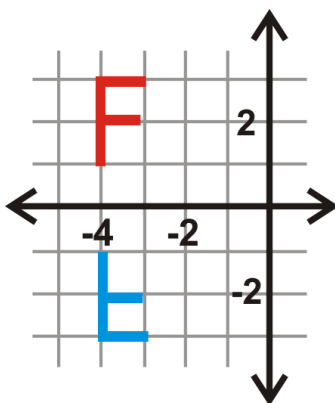

Example B

Reflect $\triangle ABC$ over the y -axis. Find the coordinates of the image.

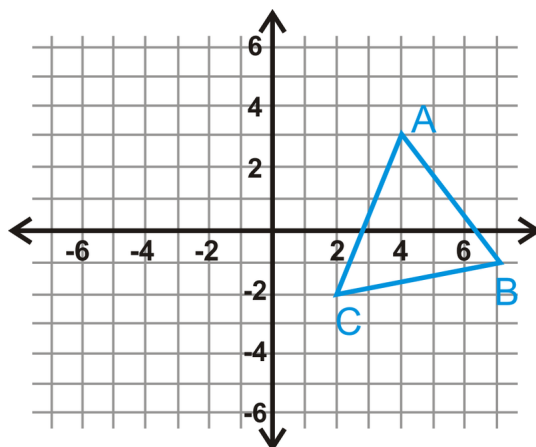

To reflect $\triangle ABC$ over the y -axis the y -coordinates will remain the same. The x -coordinates will be the same distance away from the y -axis, but on the other side of the y -axis.

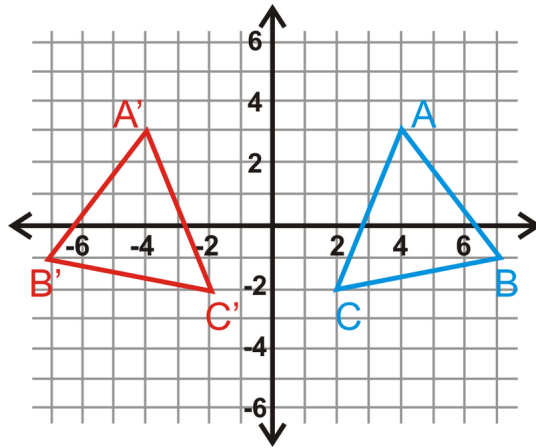

$$\begin{aligned} A(4, 3) &\rightarrow A'(-4, 3) \\ B(7, -1) &\rightarrow B'(-7, -1) \\ C(2, -2) &\rightarrow C'(-2, -2) \end{aligned}$$

Example C

Reflect the triangle $\triangle ABC$ with vertices $A(4, 5)$, $B(7, 1)$ and $C(9, 6)$ over the line $x = 5$.

Notice that this vertical line is through our preimage. Therefore, the image's vertices are the same distance away from $x = 5$ as the preimage. As with reflecting over the y -axis (or $x = 0$), the y -coordinates will stay the same.

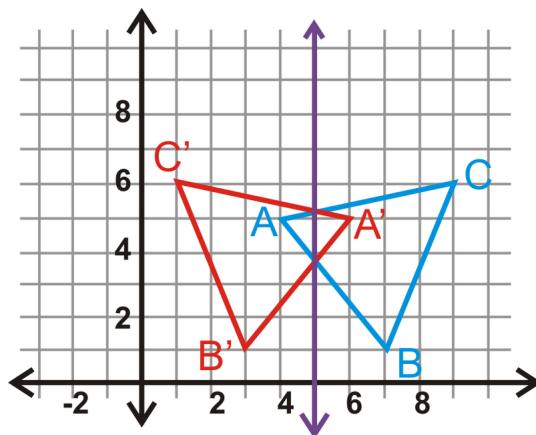

$$\begin{aligned} A(4, 5) &\rightarrow A'(6, 5) \\ B(7, 1) &\rightarrow B'(3, 1) \\ C(9, 6) &\rightarrow C'(1, 6) \end{aligned}$$

Example D

Reflect square $ABCD$ over the line $y = x$.

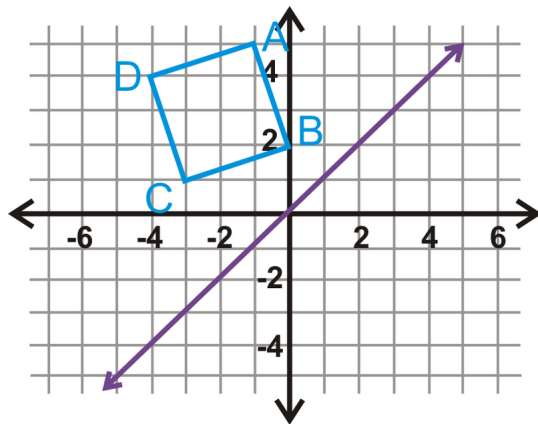

The purple line is $y = x$. To reflect an image over a line that is not vertical or horizontal, you can fold the graph on the line of reflection.

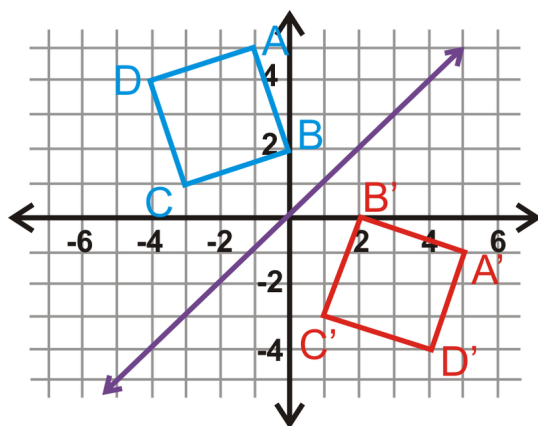

$$A(-1, 5) \rightarrow A'(5, -1)$$

$$B(0, 2) \rightarrow B'(2, 0)$$

$$C(-3, 1) \rightarrow C'(1, -3)$$

$$D(-4, 4) \rightarrow D'(4, -4)$$

Watch this video for help with the Examples above.



MEDIA

Click image to the left for more content.

[CK-12 Foundation: Chapter12ReflectionsB](#)

Concept Problem Revisited

The white line in the picture is the line of reflection. This line coincides with the water's edge. If we were to place this picture on the coordinate plane, the line of reflection would be any horizontal line. One example could be the x -axis.



Vocabulary

A **transformation** is an operation that moves, flips, or otherwise changes a figure to create a new figure. A **rigid transformation** (also known as an **isometry** or **congruence transformation**) is a transformation that does not change the size or shape of a figure. The new figure created by a transformation is called the **image**. The original figure is called the **preimage**. A **reflection** is a transformation that turns a figure into its mirror image by flipping it over a line. The **line of reflection** is the line that a figure is reflected over.

Guided Practice

1. Reflect the line segment \overline{PQ} with endpoints $P(-1, 5)$ and $Q(7, 8)$ over the line $y = 5$.
2. A triangle $\triangle LMN$ and its reflection, $\triangle L'M'N'$ are to the left. What is the line of reflection?

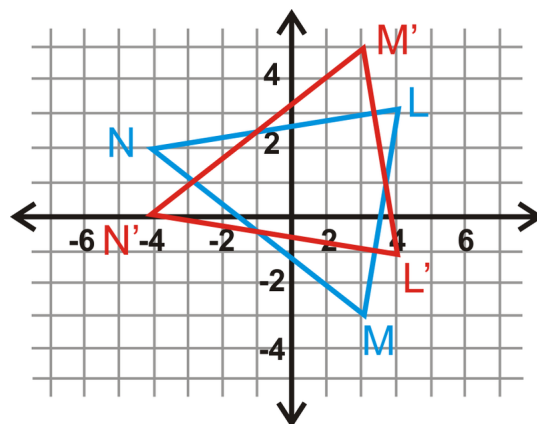

3. Reflect the trapezoid $TRAP$ over the line $y = -x$.

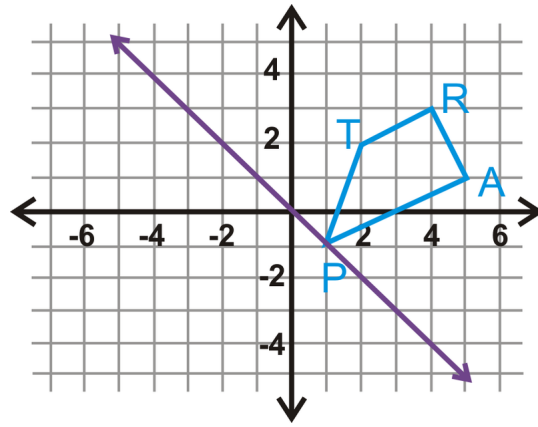

Answers:

1. Here, the line of reflection is on P , which means P' has the same coordinates. Q' has the same x -coordinate as Q and is the same distance away from $y = 5$, but on the other side.

$$P(-1, 5) \rightarrow P'(-1, 5)$$

$$Q(7, 8) \rightarrow Q'(7, 2)$$

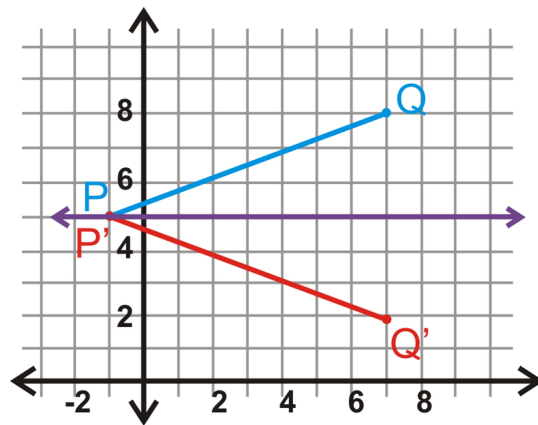

2. Looking at the graph, we see that the preimage and image intersect when $y = 1$. Therefore, this is the line of reflection.

3. The purple line is $y = -x$. You can reflect the trapezoid over this line just like we did in Example D.

$$T(2, 2) \rightarrow T'(-2, -2)$$

$$R(4, 3) \rightarrow R'(-3, -4)$$

$$A(5, 1) \rightarrow A'(-1, -5)$$

$$P(1, -1) \rightarrow P'(1, -1)$$

Practice

1. Which letter is a reflection over a vertical line of the letter “ b'' ”?
2. Which letter is a reflection over a horizontal line of the letter “ b'' ”?

Reflect each shape over the given line.

3. y -axis

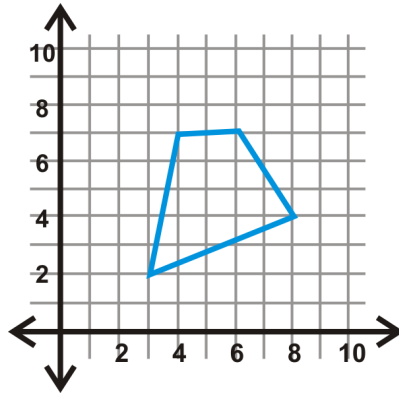

4. x -axis

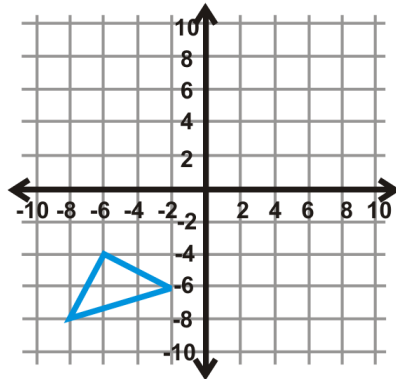

5. $y = 3$

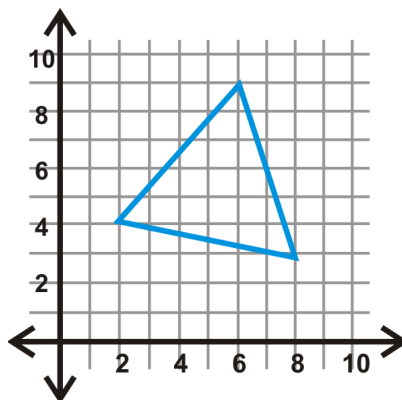

6. $x = -1$

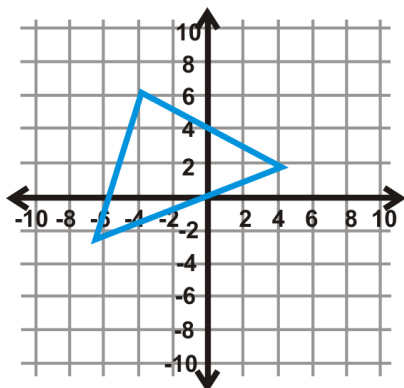

Find the line of reflection of the blue triangle (preimage) and the red triangle (image).

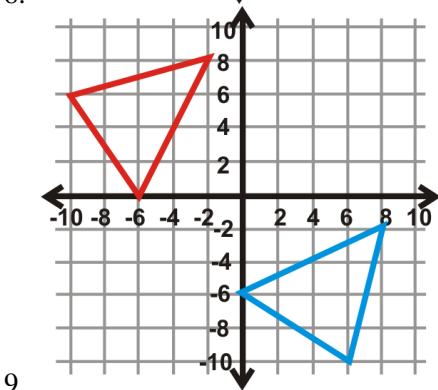
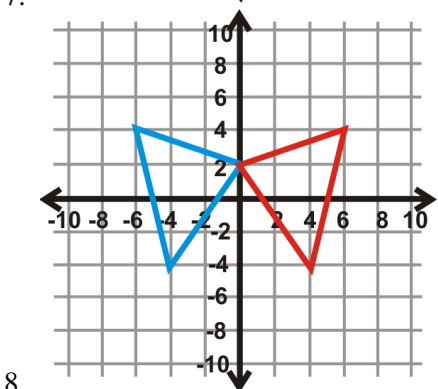
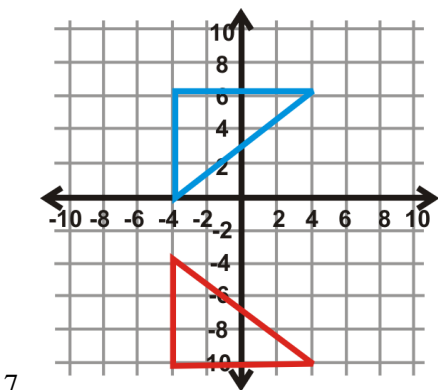

Two Reflections The vertices of $\triangle ABC$ are $A(-5, 1)$, $B(-3, 6)$, and $C(2, 3)$. Use this information to answer questions 10-13.

10. Plot $\triangle ABC$ on the coordinate plane.

11. Reflect $\triangle ABC$ over $y = 1$. Find the coordinates of $\triangle A'B'C'$.
12. Reflect $\triangle A'B'C'$ over $y = -3$. Find the coordinates of $\triangle A''B''C''$.
13. What **one** transformation would be the same as this double reflection?

Two Reflections The vertices of $\triangle DEF$ are $D(6, -2)$, $E(8, -4)$, and $F(3, -7)$. Use this information to answer questions 14-17.

14. Plot $\triangle DEF$ on the coordinate plane.
15. Reflect $\triangle DEF$ over $x = 2$. Find the coordinates of $\triangle D'E'F'$.
16. Reflect $\triangle D'E'F'$ over $x = -4$. Find the coordinates of $\triangle D''E''F''$.
17. What **one** transformation would be the same as this double reflection?

Two Reflections The vertices of $\triangle GHI$ are $G(1, 1)$, $H(5, 1)$, and $I(5, 4)$. Use this information to answer questions 18-21.

18. Plot $\triangle GHI$ on the coordinate plane.
19. Reflect $\triangle GHI$ over the x -axis. Find the coordinates of $\triangle G'H'I'$.
20. Reflect $\triangle G'H'I'$ over the y -axis. Find the coordinates of $\triangle G''H''I''$.
21. What **one** transformation would be the same as this double reflection?

12.6 Composition of Transformations

Here you'll learn how to perform a composition of transformations. You'll also learn some common composition of transformations.

What if you were told that your own footprint is an example of a glide reflection? The equations to find your average footprint are in the diagram below. Determine your average footprint and write the rule for one stride. You may assume your stride starts at $(0, 0)$. After completing this Concept, you'll be able to answer this question.

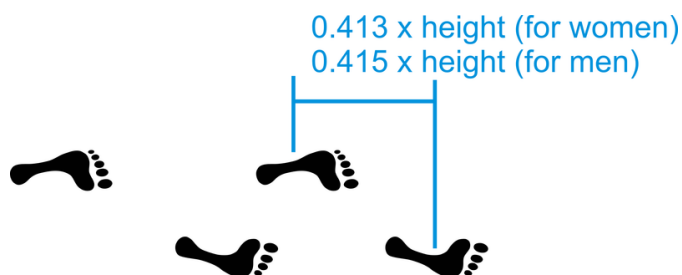

Watch This



MEDIA

Click image to the left for more content.

[CK-12 Foundation: Chapter12CompositionofTranformationsA](#)

Learn more aboutcompositions oftransformationsby watchingthevideo at this link.

Follow this linkto learn about glide reflections.

Guidance

Transformations Summary

A **transformation** is an operation that moves, flips, or otherwise changes a figure to create a new figure. A **rigid transformation** (also known as an **isometry** or **congruence transformation**) is a transformation that does not change the size or shape of a figure. The new figure created by a transformation is called the **image**. The original figure is called the **preimage**.

There are three rigid transformations: translations, reflections, and rotations. A **translation** is a transformation that moves every point in a figure the same distance in the same direction. A **rotation** is a transformation where a figure is turned around a fixed point to create an image. A **reflection** is a transformation that turns a figure into its mirror image by flipping it over a line.

Composition of Transformations

A **composition of transformations** is to perform more than one rigid transformation on a figure. One of the interesting things about compositions is that they can always be written as one rule. What this means is you don't necessarily have to perform one transformation followed by the next. You can write a rule and perform them at the same time. You can compose any transformations, but here are some of the most common compositions.

1. **Glide Reflection:** a composition of a reflection and a translation. The translation is in a direction parallel to the line of reflection.
2. **Reflections over Parallel Lines Theorem:** If you compose two reflections over parallel lines that are h units apart, it is the same as a single translation of $2h$ units. *Be careful with this theorem. Notice, it does not say which direction the translation is in. So, to apply this theorem, you would still need to visualize, or even do, the reflections to see in which direction the translation would be.*
3. **Reflection over the Axes Theorem:** If you compose two reflections over each axis, then the final image is a rotation of 180° of the original. *With this particular composition, order does not matter. Let's look at the angle of intersection for these lines. We know that the axes are perpendicular, which means they intersect at a 90° angle. The final answer was a rotation of 180° , which is double 90° . Therefore, we could say that the composition of the reflections over each axis is a rotation of double their angle of intersection.*
4. **Reflection over Intersecting Lines Theorem:** If you compose two reflections over lines that intersect at x° , then the resulting image is a rotation of $2x^\circ$, where the center of rotation is the point of intersection.

Example A

Reflect $\triangle ABC$ over the y -axis and then translate the image 8 units down.

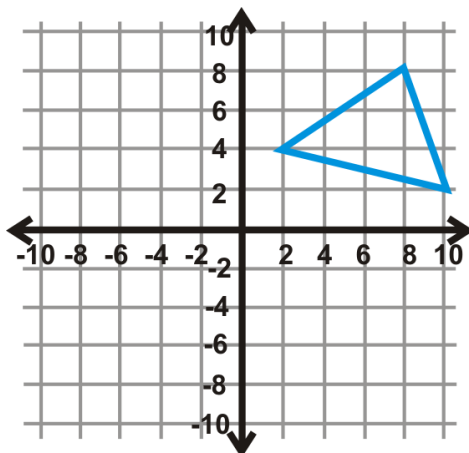

The green image below is the final answer.

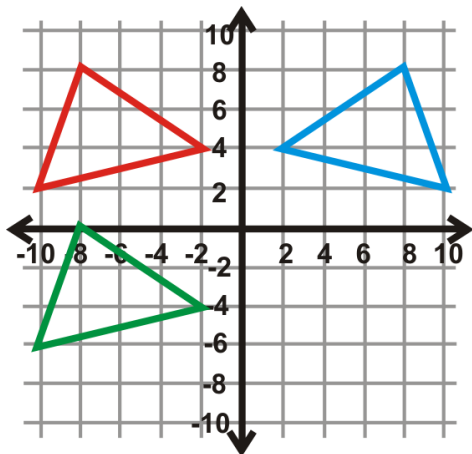

$$\begin{aligned} A(8, 8) &\rightarrow A''(-8, 0) \\ B(2, 4) &\rightarrow B''(-2, -4) \\ C(10, 2) &\rightarrow C''(-10, -6) \end{aligned}$$

Example B

Write a single rule for $\triangle ABC$ to $\triangle A''B''C''$ from Example A.

Looking at the coordinates of A to A'' , the x -value is the opposite sign and the y -value is $y - 8$. Therefore the rule would be $(x, y) \rightarrow (-x, y - 8)$.

Notice that this follows the rules we have learned in previous sections about a reflection over the y -axis and translations.

Example C

Reflect $\triangle ABC$ over $y = 3$ and $y = -5$.

Unlike a glide reflection, order matters. Therefore, you would reflect over $y = 3$ first, followed by a reflection of this image (red triangle) over $y = -5$. Your answer would be the green triangle in the graph below.

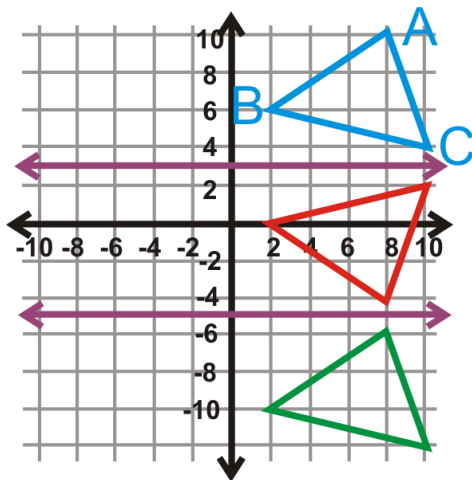

Example D

Copy the figure below and reflect it over l , followed by m .

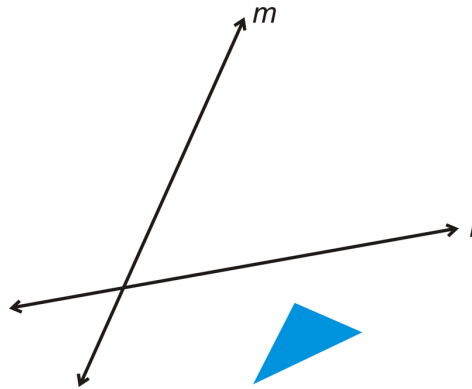

The easiest way to reflect the triangle is to fold your paper on each line of reflection and draw the image. It should look like this:

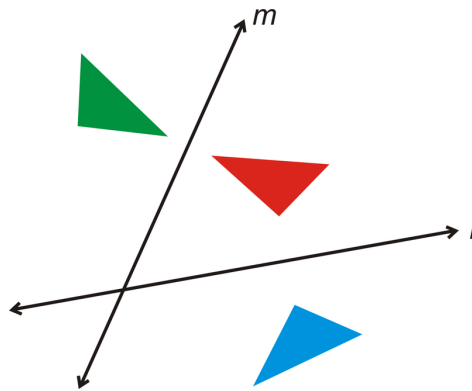

The green triangle would be the final answer.

Watch this video for help with the Examples above.



MEDIA

Click image to the left for more content.

[CK-12 Foundation: Chapter12CompositionofTransformationsB](#)

Concept Problem Revisited

The average 6 foot tall man has a $0.415 \times 6 = 2.5$ foot stride. Therefore, the transformation rule for this person would be $(x, y) \rightarrow (-x, y + 2.5)$.

Vocabulary

A **transformation** is an operation that moves, flips, or otherwise changes a figure to create a new figure. A **rigid transformation** (also known as an **isometry** or **congruence transformation**) is a transformation that does not change

the size or shape of a figure. The new figure created by a transformation is called the *image*. The original figure is called the *preimage*.

There are three rigid transformations: translations, reflections, and rotations. A *translation* is a transformation that moves every point in a figure the same distance in the same direction. A *rotation* is a transformation where a figure is turned around a fixed point to create an image. A *reflection* is a transformation that turns a figure into its mirror image by flipping it over a line.

A *composition (of transformations)* is when more than one transformation is performed on a figure. A *glide reflection* is a composition of a reflection and a translation. The translation is in a direction parallel to the line of reflection.

Guided Practice

- $\triangle DEF$ has vertices $D(3, -1)$, $E(8, -3)$, and $F(6, 4)$. Reflect $\triangle DEF$ over $x = -5$ and $x = 1$. This double reflection would be the same as which one translation?
- Reflect $\triangle DEF$ from #1 over the x -axis, followed by the y -axis. Determine the coordinates of $\triangle D''E''F''$ and what one transformation this double reflection would be the same as.
- Reflect the square over $y = x$, followed by a reflection over the x -axis.

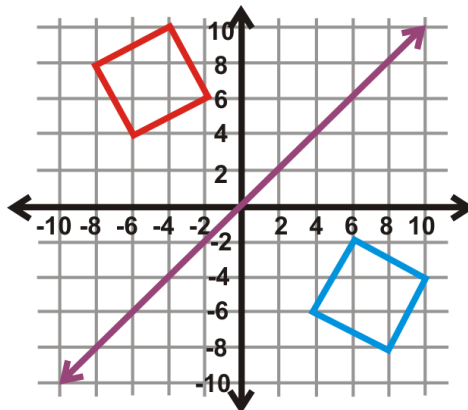
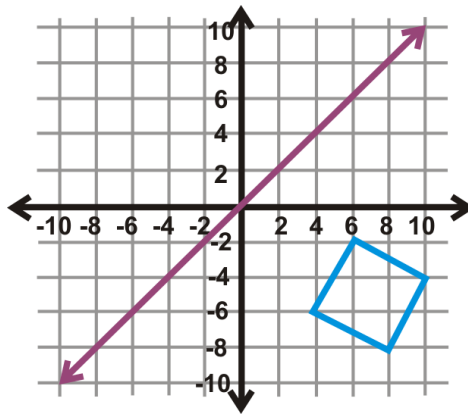

- Determine the one rotation that is the same as the double reflection from #3.

Answers:

- From the Reflections over Parallel Lines Theorem, we know that this double reflection is going to be the same as a single translation of $2(1 - (-5))$ or 12 units. Now, we need to determine if it is to the right or to the left. Because we first reflect over a line that is further away from $\triangle DEF$, to the *left*, $\triangle D''E''F''$ will be on the *right* of $\triangle DEF$. So,

it would be the same as a translation of 12 units to the right. If the lines of reflection were switched and we reflected the triangle over $x = 1$ followed by $x = -5$, then it would have been the same as a translation of 12 units to the *left*.

2. $\triangle D''E''F''$ is the green triangle in the graph below. If we compare the coordinates of it to $\triangle DEF$, we have:

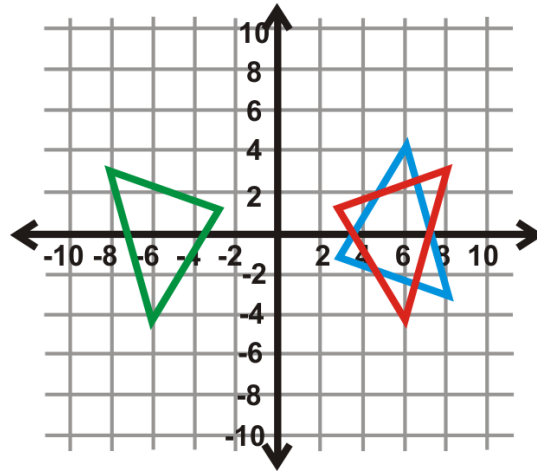

$$D(3, -1) \rightarrow D'(-3, 1)$$

$$E(8, -3) \rightarrow E'(-8, 3)$$

$$F(6, 4) \rightarrow F'(-6, -4)$$

If you recall the rules of rotations from the previous section, this is the same as a rotation of 180° .

3. First, reflect the square over $y = x$. The answer is the red square in the graph above. Second, reflect the red square over the x -axis. The answer is the green square below.

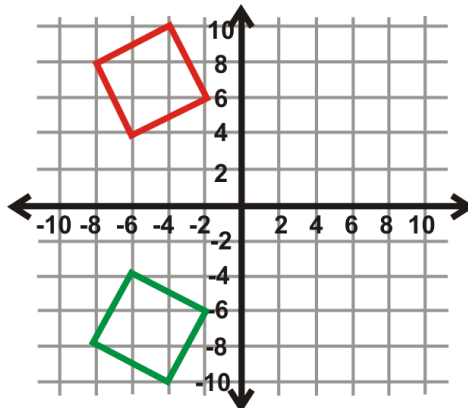

4. Let's use the theorem above. First, we need to figure out what the angle of intersection is for $y = x$ and the x -axis. $y = x$ is halfway between the two axes, which are perpendicular, so is 45° from the x -axis. Therefore, the angle of rotation is 90° clockwise or 270° counterclockwise. The correct answer is 270° counterclockwise because we always measure angle of rotation in the coordinate plane in a counterclockwise direction. From the diagram, we could have also said the two lines are 135° apart, which is supplementary to 45° .

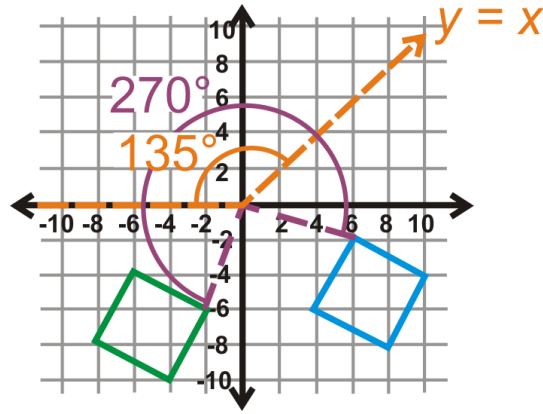

Practice

1. What one transformation is equivalent to a reflection over two parallel lines?
2. What one transformation is equivalent to a reflection over two intersecting lines?

Use the graph of the square below to answer questions 3-6.

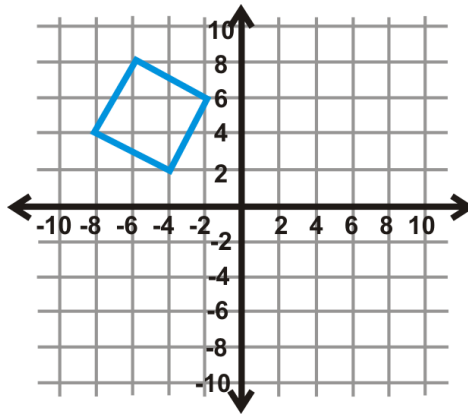

3. Perform a glide reflection over the x -axis and to the right 6 units. Write the new coordinates.
4. What is the rule for this glide reflection?
5. What glide reflection would move the image back to the preimage?
6. Start over. Would the coordinates of a glide reflection where you move the square 6 units to the right and then reflect over the x -axis be any different than #3? Why or why not?

Use the graph of the triangle below to answer questions 7-9.

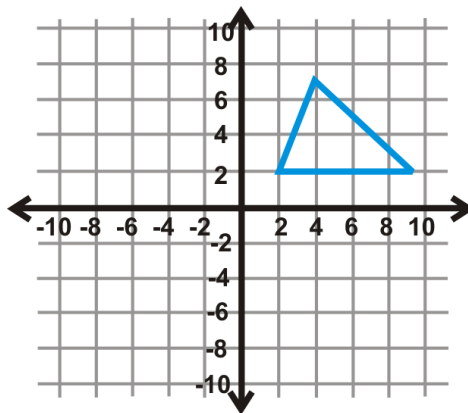

7. Perform a glide reflection over the y -axis and down 5 units. Write the new coordinates.
8. What is the rule for this glide reflection?
9. What glide reflection would move the image back to the preimage?

Use the graph of the triangle below to answer questions 10-14.

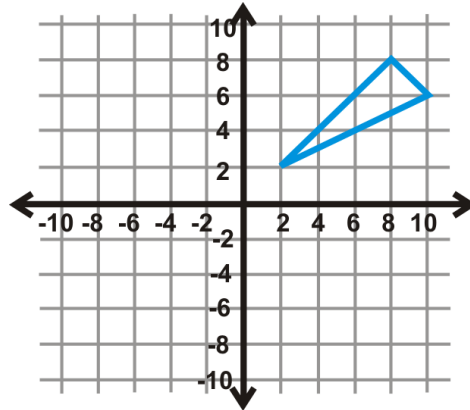

10. Reflect the preimage over $y = -1$ followed by $y = -7$. Write the new coordinates.
11. What one transformation is this double reflection the same as?
12. What one translation would move the image back to the preimage?
13. Start over. Reflect the preimage over $y = -7$, then $y = -1$. How is this different from #10?
14. Write the rules for #10 and #13. How do they differ?

Fill in the blanks or answer the questions below.

15. Two parallel lines are 7 units apart. If you reflect a figure over both how far apart with the preimage and final image be?
16. After a double reflection over parallel lines, a preimage and its image are 28 units apart. How far apart are the parallel lines?
17. A double reflection over the x and y axes is the same as a _____ of _____.
18. What is the center of rotation for #17?
19. Two lines intersect at an 83° angle. If a figure is reflected over both lines, how far apart will the preimage and image be?
20. A preimage and its image are 244° apart. If the preimage was reflected over two intersected lines, at what angle did they intersect?
21. After a double reflection over parallel lines, a preimage and its image are 62 units apart. How far apart are the parallel lines?
22. A figure is to the left of $x = a$. If it is reflected over $x = a$ followed by $x = b$ and $b > a$, then the preimage and image are _____ units apart and the image is to the _____ of the preimage.

12.7 Tessellations

Here you'll learn what a tessellation is and how to tell whether or not a figure will tessellate.

What if you were given a hexagon and asked to tile it over a plane such that it would fill the plane with no overlaps and no gaps? Could you do this? After completing this Concept, you'll be able to determine if a figure tessellates.

Watch This



MEDIA

Click image to the left for more content.

[CK-12 Foundation: Chapter12TessallationsA](#)

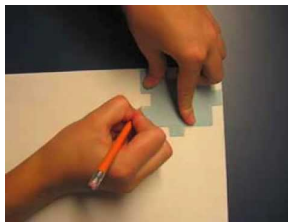

MEDIA

Click image to the left for more content.

[Teachertubemath:Create a Tessellation](#)

Guidance

You have probably seen tessellations before, even though you did not call them that. Examples of tessellations are: a tile floor, a brick or block wall, a checker or chess board, and a fabric pattern. A **tessellation** is a tiling over a plane with one or more figures such that the figures fill the plane with no overlaps and no gaps. Here are a few examples.

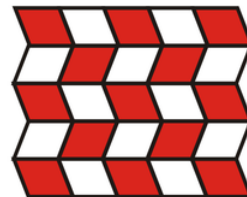
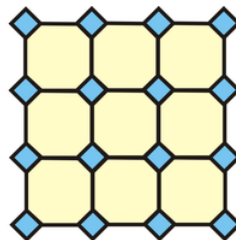
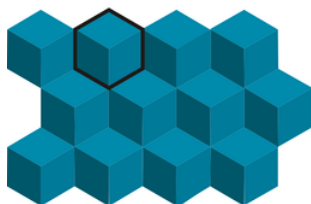

Notice the hexagon (cubes, first tessellation) and the quadrilaterals fit together perfectly. If we keep adding more, they will entirely cover the plane with no gaps or overlaps. The tessellation pattern could be colored creatively to make interesting and/or attractive patterns. To tessellate a shape it must be able to exactly surround a point, or the sum of the angles around each point in a tessellation must be 360° . Therefore, every quadrilateral and hexagon will tessellate. For a shape to be tessellated, the angles around every point must add up to 360° . A regular pentagon does

not tessellate by itself. But, if we add in another shape, a rhombus, for example, then the two shapes together will tessellate.

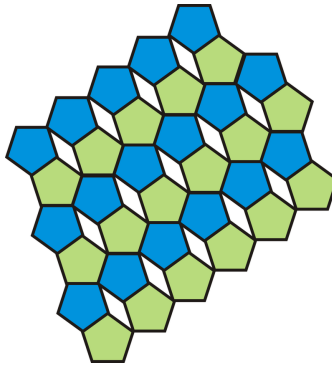

Tessellations can also be much more complicated. Here are a couple of examples.



Example A

Tessellate the quadrilateral below.

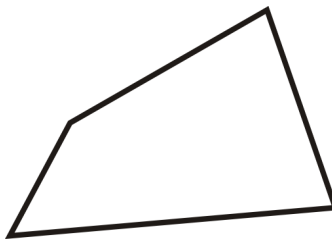

To tessellate any image you will need to reflect and rotate the image so that the sides all fit together. First, start by matching up each side with itself around the quadrilateral.

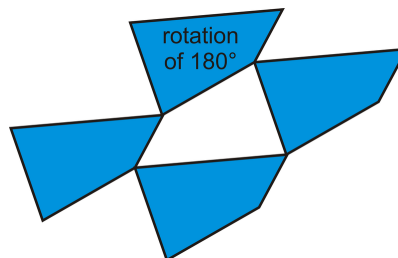

This is the final tessellation. You can continue to tessellate this shape forever. Now, continue to fill in around the figures with either the original or the rotation.

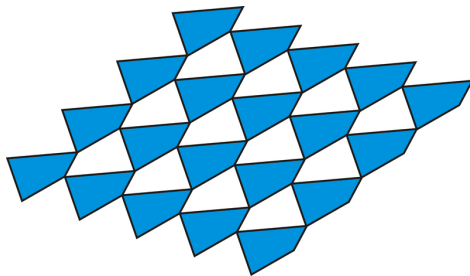

Example B

Does a regular pentagon tessellate?

First, recall that there are $(5 - 2)180^\circ = 540^\circ$ in a pentagon and each angle is $540^\circ \div 5 = 108^\circ$. From this, we know that a regular pentagon will not tessellate by itself because $108^\circ \times 3 = 324^\circ$ and $108^\circ \times 4 = 432^\circ$.

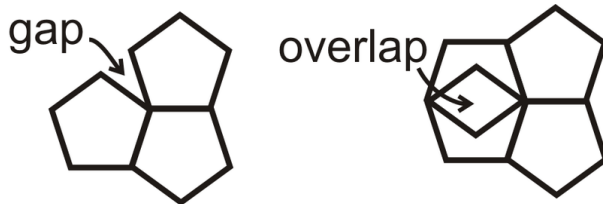

Example C

How many squares will fit around one point?

First, recall how many degrees are in a circle, and then figure out how many degrees are in each angle of a square. There are 360° in a circle and 90° in each interior angle of a square, so $\frac{360}{90} = 4$ squares will fit around one point.

Watch this video for help with the Examples above.



MEDIA

Click image to the left for more content.

[CK-12 Foundation: Chapter12TessallationsB](#)

Concept Problem Revisited

You could tessellate a regular hexagon over a plane with no overlaps or gaps because each of its interior angles is 120° . Three hexagons whose angles sum to 360° surround each point in the tessellation.

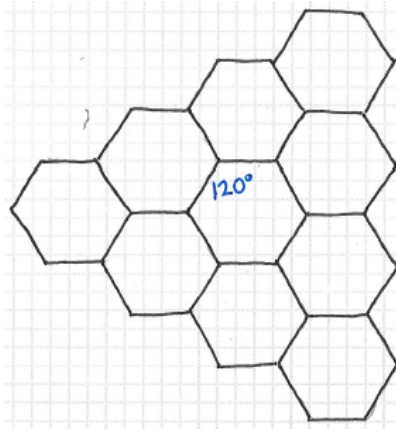

Vocabulary

A **tessellation** is a tiling over a plane with one or more figures such that the figures fill the plane with no overlaps and no gaps.

Guided Practice

1. How many regular hexagons will fit around one point?
2. Does a regular octagon tessellate?
3. Tessellations can also be much more complicated. Check out <http://www.mathsisfun.com/geometry/tessellation.html> to see other tessellations and play with the Tessellation Artist, which has a link at the bottom of the page.

Answers:

1. First, recall how many degrees are in a circle, and then figure out how many degrees are in each angle of a regular hexagon. There are 360° in a circle and 120° in each interior angle of a hexagon, so $\frac{360}{120} = 3$ hexagons will fit around one point.
2. First, recall that there are 1080° in a pentagon. Each angle in a regular pentagon is $1080^\circ \div 8 = 135^\circ$. From this, we know that a regular octagon will not tessellate by itself because 135° does not go evenly into 360° .

Practice

Will the given shapes tessellate? If so, how many do you need to fit around a single point?

1. A regular heptagon
2. A rectangle
3. A rhombus
4. A parallelogram
5. A trapezoid
6. A kite
7. A regular nonagon
8. A regular decagon
9. A completely irregular quadrilateral
10. In general, which regular polygons will tessellate?
11. Use equilateral triangles and regular hexagons to draw a tessellation.
12. The blue shapes are regular octagons. Determine what type of polygon the white shapes are. Be as specific as you can.

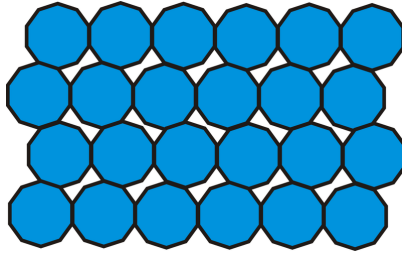

13. Draw a tessellation using regular hexagons.
14. Draw a tessellation using octagons and squares.
15. Make a tessellation of an irregular quadrilateral using the directions from Example A.

Summary

This chapter discusses transformations of figures in the two-dimensional space. It begins with an explanation of reflection and rotation symmetry. The chapter then branches out to discuss the different types of rigid transformations: translation (sliding a figure to a new position), rotation (rotating a figure with respect to an axis), and reflection (flipping a figure along a line of symmetry). Once the different types of basic transformations are discussed, the composition of these actions to create a new type of transformation is explored. The chapter wraps up with a detailed presentation of tessellations.

Chapter Keywords

- Line of Symmetry
- Line Symmetry
- Rotational Symmetry
- Center of Rotation
- angle of rotation
- Transformation
- Rigid Transformation
- Translation
- Vector
- Reflection
- Line of Reflection
- Reflection over the y -axis
- Reflection over the x -axis
- Reflection over $x = a$
- Reflection over $y = b$
- Reflection over $y = x$
- Reflection over $y = -x$
- Rotation
- Center of Rotation
- Rotation of 180°
- Rotation of 90°
- Rotation of 270°
- Composition (of transformations)
- Glide Reflection
- Reflections over Parallel Lines Theorem
- Reflection over the Axes Theorem

- Reflection over Intersecting Lines Theorem
- Tessellation

Chapter Review

Match the description with its rule.

1. Reflection over the y -axis - A. $(2a - x, y)$
2. Reflection over the x -axis - B. $(-y, -x)$
3. Reflection over $x = a$ - C. $(-x, y)$
4. Reflection over $y = b$ - D. $(-y, x)$
5. Reflection over $y = x$ - E. $(x, -y)$
6. Reflection over $y = -x$ - F. $(x, 2b - y)$
7. Rotation of 180° - G. (x, y)
8. Rotation of 90° - H. $(-x, -y)$
9. Rotation of 270° - I. $(y, -x)$
10. Rotation of 360° - J. (y, x)

Texas Instruments Resources

In the CK-12 Texas Instruments Geometry FlexBook, there are graphing calculator activities designed to supplement the objectives for some of the lessons in this chapter. See <http://www.ck12.org/flexr/chapter/9697>.