



Analysis of the Exposure Levels and Potential Biologic Effects of the PAVE PAWS Radar System (1979)

Pages
109

Size
8.5 x 10

ISBN
0309333660

Panel on the Extent of Radiation from the PAVE PAWS Radar System; Assembly of Life Sciences; National Research Council

 [Find Similar Titles](#)

 [More Information](#)

Visit the National Academies Press online and register for...

- ✓ Instant access to free PDF downloads of titles from the
 - NATIONAL ACADEMY OF SCIENCES
 - NATIONAL ACADEMY OF ENGINEERING
 - INSTITUTE OF MEDICINE
 - NATIONAL RESEARCH COUNCIL
- ✓ 10% off print titles
- ✓ Custom notification of new releases in your field of interest
- ✓ Special offers and discounts

Distribution, posting, or copying of this PDF is strictly prohibited without written permission of the National Academies Press. Unless otherwise indicated, all materials in this PDF are copyrighted by the National Academy of Sciences.

To request permission to reprint or otherwise distribute portions of this publication contact our Customer Service Department at 800-624-6242.

Copyright © National Academy of Sciences. All rights reserved.



**Analysis of the Exposure Levels and Potential Biologic Effects
of the PAVE PAWS Radar System**

National Research Council Washington DC Panel on the Extent of
Radiation From the PAVE PAWS Radar System*Air Force Systems
Command, Washington, DC (411318)

Final rept.

AUTHOR: Cleary, Stephen F.; Adey, W. Ross; Gandhi, Om P.;
Justesen, Don R.; McMillan, Brockway
F214284 Fld: 171, GR, 63H, 68F, 57V GRAI7924
1979 110p

Contract: F49620-78-C-0118

Monitor: AFSC-TR-79-07

See also AD-A072 333.

Abstract: The Panel on the Extent of Radiation from the PAVE PAWS Radar System was charged to examine the extent of radiation and the exposure of the public to radiation from the PAVE PAWS system. In carrying out this task, the Panel has considered the characteristics of the PAVE PAWS radiation as related to public exposure and compared the possible exposure to existing ambient radiofrequency radiation on Cape Cod and in other locations in the United States. To provide perspective for the assessment of possible exposure effects the Panel has also, to the extent possible, reviewed and summarized the state of knowledge concerning the biologic effects of exposure to such radiation. The Panel did not address the question of the desirability or adequacy of the anticipated exposure control procedures, nor did it make a judgment concerning the relative safety or hazard of exposure to PAVE PAWS emission.

Descriptors: *Radar antennas, *Radiation hazards, Microwaves, Field intensity, Low intensity, Radar beams, Exposure(Physiology), Humans, Central nervous system, Pacemakers, Antimissile defense systems, Radar stations, Massachusetts, Air Force facilities

Identifiers: PAVE PAWS project, Otis Air Force Base, Radiation effects(Biology), Cape Cod, NTISDODXA, NTISDODAF

AD-A072 332/0ST NTIS Prices: PC A06/MF A01

REFERENCE COPY
FOR LIBRARY USE ONLY

ANALYSIS OF THE EXPOSURE LEVELS AND POTENTIAL
BIOLOGIC EFFECTS OF THE PAVE PAWS RADAR SYSTEM

Panel on the Extent of Radiation
from the PAVE PAWS Radar System

Assembly of Life Sciences
National Research Council

National Academy of Sciences
Washington, D.C.
1979

NACNRE

MAY 7 1979

LIBRARY

TK
6575
1152
1979
C.1

NOTICE

The project that is the subject of this report was approved by the Governing Board of the National Research Council, whose members are drawn from the Councils of the National Academy of Sciences, the National Academy of Engineering, and the Institute of Medicine. The members of the Committee responsible for the report were chosen for their special competences and with regard for appropriate balance.

This report has been reviewed by a group other than the authors according to procedures approved by a Report Review Committee consisting of members of the National Academy of Sciences, the National Academy of Engineering, and the Institute of Medicine.

The work on which this report is based was performed pursuant to Contract No. F49620-78-C-0118 with the United States Air Force.

ASSEMBLY OF LIFE SCIENCES
PANEL ON THE EXTENT OF RADIATION
FROM THE PAVE PAWS RADAR SYSTEM

MEMBERS

Stephen F. Cleary, Chairman
Department of Biophysics
Virginia Commonwealth University
Richmond, VA

W. Ross Adey
Veterans' Administration
Medical Center
Loma Linda, CA

Om P. Gandhi
Department of Electrical
Engineering and Bioengineering
University of Utah
Salt Lake City, UT

Don R. Justesen
Neuro-Psychology and Behavioral
Radiology Laboratories
Veterans' Administration Medical
Center
Kansas City, MO

Brockway McMillan
Vice President, Military Systems
Bell Telephone Laboratories, Inc.
Whippany, NJ

Shields Warren
Cancer Research Institute
New England Deaconess Hospital
Boston, MA

Clayton S. White
President
Oklahoma Medical Research
Foundation
Oklahoma City, OK

George M. Wilkening
Head, Environmental Health
and Safety Department
Bell Telephone Laboratories, Inc.
Murray Hill, NJ

CONSULTANTS

Arthur W. Guy
Department of Rehabilitation
Medicine
University of Washington
Seattle, WA

David E. Janes
Chief, Electromagnetic
Radiation Analysis Branch
Environmental Analysis Division
Environmental Protection Agency
Silver Spring, MD

Oswald G. Villard, Jr.
SRI International
Menlo Park, CA

EDITOR

Norman Grossblatt
Assembly of Life Sciences
National Research Council
Washington, D.C.

PREFACE

The Panel on the Extent of Radiation from the PAVE PAWS Radar System was charged to examine the extent of radiation and the exposure of the public to radiation from the PAVE PAWS system. In carrying out this task, the Panel has considered the characteristics of the PAVE PAWS radiation as related to public exposure and compared the possible exposure to existing ambient radiofrequency radiation on Cape Cod and in other locations in the United States. To provide perspective for the assessment of possible exposure effects the Panel has also, to the extent possible, reviewed and summarized the state of knowledge concerning the biologic effects of exposure to such radiation.

The Panel did not address the question of the desirability or adequacy of the anticipated exposure control procedures, nor did it make a judgment concerning the relative safety or hazard of exposure to PAVE PAWS emission.

I wish to thank the members of the Panel for their commitment to the completion of this report and the Air Force personnel who cooperated in supplying necessary information.

Stephen F. Cleary, Chairman
Panel on the Extent of
Radiation from the PAVE
PAWS Radar System

EXECUTIVE SUMMARY

HISTORICAL PERSPECTIVE

"PAVE PAWS" is the name used by the U.S. Air Force for a fixed-base solid-state radar system, including a radar at Otis Air Force Base, on Cape Cod, Massachusetts. Its primary purpose is to detect and determine attack characteristics of sea-launched ballistic missiles that might penetrate the PAVE PAWS field of view. As a secondary function, PAVE PAWS will support the Air Force Spacetrack System by providing surveillance and tracking of earth satellites and identification of other space objects. An identical radar with similar functions will be constructed at Beale Air Force Base, California.

The PAVE PAWS project was conceived as a result of a memorandum issued on November 6, 1972, by the Joint Chiefs of Staff. The Raytheon Company was selected as the primary contractor on April 12, 1976. The project manager for the Air Force Systems Command is the Electronic Systems Division, Hanscom Air Force Base, Bedford, Massachusetts.

On March 17, 1976, the Air Force issued an environmental assessment of PAVE PAWS. This document was prepared in August 1975 and later revised. For purposes of this assessment, a power density or incident intensity of 10 milliwatts per square centimeter (mW/cm^2) as averaged over any 6-min period was established as a guideline for limiting occupational exposure. The guideline was provided by the U.S. Air Force School of Aerospace Medicine, Brooks Air Force Base, San Antonio, Texas, on the basis of existing Occupational Safety and Health Administration guidelines. Guidelines were not specified for nonoccupational exposure.

The Electromagnetic Compatibility Analysis Center (ECAC) contracted with the Illinois Institute of Technology Research Institute for a report on the PAVE PAWS project. This report was issued in May 1976 and updated in July 1978. Its objective was to determine the impact of the proposed PAVE PAWS radar system on the electromagnetic environment at and near Otis Air Force Base. The ECAC, a Department of Defense (DOD) facility, was established to provide advice and assistance on electromagnetic compatibility to the Secretary of Defense, the Joint Chiefs of Staff, the military departments, and other DOD components.

On December 22, 1977, the Environmental Protection Agency (EPA) prepared an environmental impact analysis of the PAVE PAWS system at the request of Representative Gerry E. Studds, 12th Congressional District, Massachusetts.

The Cape Cod Environmental Coalition, Inc., a citizens group, undertook court action in the U.S. District Court against various Air Force officials on March 3, 1978 (amended April 12, 1978). The main issue was that the Otis Air Force Base PAVE PAWS project was in violation of the National Environmental Policy Act of 1969 (42 U.S.C. 4321 et seq.), because an environmental impact statement (EIS) had not been prepared.

On April 11, 1978, Air Force officials announced that they would complete an EIS for the Otis Air Force Base PAVE PAWS system; Stanford Research International was to provide the EIS under contract with the Air Force.

The Air Force asked the National Academy of Sciences to perform two studies relevant to the EIS. One would focus on the safety measures inherent in the engineering design of the radar system and would be prepared by a panel of the National Research Council's Assembly of Engineering. The second, on the extent of human exposure, the subject of this report, was performed by a panel administered by the National Research Council's Assembly of Life Sciences.

An Air Force survey team measured the microwave radiation at four locations in front of the south face of the PAVE PAWS radar on August 26, 1978. On October 20-21, 1978, the team measured the microwave radiation at 21 locations when both faces of the PAVE PAWS radar were operating under normal conditions. In all cases, the tests were witnessed by designated independent observers from the surrounding communities.

On October 31, 1978, the Cape Cod Environmental Coalition, Inc., and the U.S. Air Force entered into a stipulation agreement, temporarily suspending further litigation brought by some Cape Cod residents against the Air Force in connection with the Otis Air Force Base PAVE PAWS system. Under the agreement, the Air Force is allowed to continue with construction of the facility while it completes an environmental study of the facility. The Coalition and the Air Force have agreed that, in the event of further litigation, the issues to be litigated will be limited to allegations related to the substantive sufficiency of the environmental study. Such allegations must be made by the Coalition during the 45-day public-comment period to be scheduled by the Air Force.

CHARACTERISTICS OF PAVE PAWS EXPOSURE CONDITIONS

Chapter 1 of this report describes the operating characteristics of PAVE PAWS as they are related to possible exposure effects on humans, as well as the safety measures used to control unwarranted exposure.

Radar systems like PAVE PAWS typically radiate beams of energy at microwave frequencies in short pulses of high peak power and scan such that the beam direction is constantly altered, in contrast with FM and TV broadcast stations, which radiate energy diffusely at a fairly constant power.

The PAVE PAWS radar system pulses ultrahigh-frequency (420-450 megahertz, or MHz) nonionizing radiation focused in a plane 3-85° above the horizon with a scanning sector of 120°. The peak radiated power of the radar is 580 kilowatts (kW), and the time-averaged power of transmitted energy is approximately 145 kW. The time-averaged power of the PAVE PAWS radar is thus approximately 3 times the average power transmitted by a large TV broadcast station and somewhat more than the average power of a large FM broadcast station. Because the beam is directed above the horizon, people at ground level may be exposed to "sidelobes" of the main beam, but not to the main beam itself. Sidelobes are secondary beams of much lower intensity than the main beam. Inasmuch as there can be many sidelobes of the main beam, potential exposures of members of the public would be to a time-varying field at a substantially lower power than that of the main beam.

Microwave exposure of humans could be greater in the event of failure of the radar system to operate in the mode described above. For example, increased exposure could result if a well-formed beam of the radar were directed at an angle less than 3° above the horizon, if a beam were poorly formed and had more intense sidelobes, if excessive power were transmitted, or if the beam remained in a fixed position, rather than scanning. The safety measures in the engineering design of the radar to prevent such occurrences are described in Chapter 1.

EXTENT OF RADIATION AND POPULATION EXPOSED

In December 1977, power densities that could result from PAVE PAWS operation were calculated by the EPA in the preparation of an environmental impact analysis. In 1978, the Air Force measured power densities at various points within, at, and up to 5 miles (8 km) beyond the "exclusion" fence, which is 1,000 ft (305 m) from the radar; and the National Bureau of Standards reviewed data from the Air Force's measurements and reviewed the measurement techniques (as described in Chapter 1).

In general, it was found that, at the exclusion fence, microwave power densities averaged about 5 microwatts per square centimeter ($\mu\text{W}/\text{cm}^2$), with decreasing densities at increasing distances from the radar. At the location where members of the public would most likely be exposed--3,450 ft (1,050 m) from the radar on Highway Route 6--the measured intensity was $0.06 \mu\text{W}/\text{cm}^2$. Exposure would, in general, be for various periods, depending on whether those exposed were stationary or mobile. (Time-averaged field intensity is used here and throughout the report, unless otherwise stated; see glossary.)

Data from the latest (1970) U.S. Bureau of the Census Master Enumeration District List with Coordinates permitted estimation of the number of people living in areas 5-10 miles (8-16 km) away from the radar; in 1970, 1,239 persons lived within 5 miles of the PAVE PAWS site; 11,235 within 10 miles; and 63,289 within 20 miles (32 km), with higher populations during the

vacation season. Although the data cannot be confidently used for distances of less than 5 miles from PAVE PAWS, they indicate that there is little or no habitation within a mile of the radar site.

The Air Force measurements indicated that power density does not exceed $0.1 \mu\text{W}/\text{cm}^2$ beyond about a mile from the radar site.

GENERAL ENVIRONMENTAL EXPOSURE

The population of the United States is routinely exposed to radio-frequency (RF) radiation, including microwaves whose frequency is approximately 30 MHz to 300 gigahertz (GHz). Measurements made by the EPA indicate that such exposure is due mainly to energy transmitted by AM and FM radio and vhf and uhf TV stations. Only a small part of the total radiation environment is attributable to such sources as military and civilian radar, satellite communication systems, telephone and television communication, and microwave ovens. On the basis of EPA studies in 12 large U.S. cities, it has been estimated that less than 1% of the population in these cities is exposed to RF radiation intensities of over $1 \mu\text{W}/\text{cm}^2$ continuously. Power densities near FM antennas and on the upper floors of tall buildings may, however, be hundreds of microwatts per square centimeter.

The EPA defines a high-power source as one in which the power density of the main beam is $100 \mu\text{W}/\text{cm}^2$ at a distance of 100 m from the antenna. Broadcast transmitters for FM radio and TV are in this category, as are radar and communication systems, such as satellite-communication earth terminals.

Although the sources of RF radiation may operate at high power output, the probability of exposure to such high-intensity fields is low, because, with the exception of broadcast transmitters, high-power sources, such as radar, use directional antennas to achieve high effective power of radiated energy. The resulting beam is unlikely to irradiate humans for sustained periods, because the beam is normally so directed as to avoid human exposure and many of the sources are remote and surrounded by exclusion areas that further reduce the probability of exposure to high-intensity fields. The duration of exposure to radiation from such sources is limited, in some cases, because of the nonstationary scanning mode of the beam.

In general, exposure of humans to radiation from most high-power sources is estimated to be at less than $50 \mu\text{W}/\text{cm}^2$ (time-averaged) at or near ground level more than 0.5 mile (0.8 km) from the source. Instantaneous peak intensities can be orders of magnitude higher for pulse-modulated radar.

BIOLOGIC CONSIDERATIONS

Chapter 2 discusses the biologic characteristics related to exposure to RF radiation and outlines the physical factors pertinent to measurement of ambient fields. Calculations of a "probable worst-case" (predicted maximal) exposure to PAVE PAWS radiation are summarized. The physical factors include the orientation of the irradiated subject relative to the electric field vector; whether the irradiated subject is in free space or in an environment where reflection may increase the field intensity; whether the energy absorption is averaged over the entire body or over local areas, such as the head or particularly absorptive areas of the body or head; and whether the irradiated subject is free-standing, grounded, or near objects that can reflect or perturb the field.

Calculations made in Chapter 2 indicate that the maximal rate of energy absorption at a "hot spot" in the head of an average adult in a building with unscreened windows, where reflections may increase the intensity of the field emanating from the PAVE PAWS radar, could be as high as 0.66 mW/g, for an incident free-space power density of 0.1 mW/cm². For purposes of comparison, normal average metabolic rates are near 3 mW/g for the whole body of an adult walking slowly and 11 mW/g in the brain.

The remainder of Chapter 2 summarizes the state of knowledge concerning biologic effects of electromagnetic radiation. Highlights are presented in the following paragraphs.

The frequencies used by the PAVE PAWS system (420-450 MHz) are in the microwave portion of the electromagnetic radiation (EMR) spectrum. It is difficult to assess the effects of exposure to such radiation, because of the lack of an adequate data base, particularly with respect to the effects of chronic or long-term exposure at low radiation intensities and because of the difficulty in determining the degree and manner in which the radiation is absorbed by biologic systems.

Radiation from the PAVE PAWS system is nonionizing. It differs from ionizing radiation, such as x rays, in that it is characterized by much lower photon energies and cannot produce damage by molecular disruption in biologic matter at low field intensities. Nonionizing radiation at high intensities can produce excessive tissue-heating, whereas at low intensities it may induce reversible effects that are not known to be hazardous in biologic systems. (In this report, 1 mW/cm² has been selected as the arbitrary boundary between high-intensity and low-intensity effects. The figure has no relationship to safe or unsafe exposure.) The available theoretical and experimental data relative to the power densities anticipated in areas of public access in the vicinity of PAVE PAWS suggest that effects in humans will be restricted to low-intensity effects, because flux densities of incident energy will apparently be below 1 mW/cm².

The Panel wishes to emphasize that the low-intensity biologic effects described in this report refer to measurable biologic alterations. Physical and chemical agents may cause alterations that are not necessarily health hazards. For example, humans perceive light and sound waves (stimuli that result in measurable biologic effects) that are not health hazards unless the light is strong enough to damage the eye or the sound is loud enough to damage the ear. The detection and measurement of such effects may, in fact, lead to a better understanding of the mechanisms by which the effects occur. In this report, the Panel has attempted to differentiate between effects of scientific interest but undetermined clinical significance and effects that may represent a potential hazard to human health.

In general, the primary reported effects of human exposure in occupational settings in which low-intensity microwaves are present are psychologic alterations--i.e., changes in mood or attitude--that suggest reversible alterations of the central nervous system. Thus, greater attention has been given to effects on the central nervous system and other nervous tissues, especially in the light of experimental evidence of power-density and modulation-frequency "windows" within which such effects appear more likely.

Data from experiments on biologic systems indicate that exposure to low-intensity microwaves can have effects. But, on the basis of most of the available findings, the known or suspected effects are reversible and are not associated with increased human morbidity or mortality.

Chapter 2 reviews in detail the data obtained from studies of the effects of microwave and RF radiation, primarily on experimental animals exposed to low-intensity fields, and discusses the human health effects of occupational exposure to low-intensity nonionizing electromagnetic fields. Assessment of data derived primarily from epidemiologic studies of occupationally exposed persons is difficult, because of the uncertainty in the degree or type of exposure. Particular attention is given to reported effects at exposures of 1 mW/cm^2 and lower, inasmuch as PAVE PAWS may be expected to produce accessible radiation well below this.

In conclusion, the PAVE PAWS radar may be anticipated to expose a limited number of members of the general public intermittently to low intensities of pulse-modulated microwave fields with maximal instantaneous intensities of $100 \text{ } \mu\text{W/cm}^2$ or less and time-averaged intensities lower by two orders of magnitude. There are no known irreversible effects of such exposure on either morbidity or mortality in humans or other species. Thus, it is improbable that exposure will present any hazard to the public. In view of the known sensitivity of the mammalian central nervous system to electromagnetic fields, especially those modulated at brainwave frequencies, the possibility cannot be ruled out that exposure to PAVE PAWS radiation may have some effects on exposed people. Because these effects are still hypothetical, it is not feasible to assess their health implications. Such assessment will require additional research and surveillance and must be addressed in future evaluations of the potential exposure effects of PAVE PAWS and other high-power-output radar systems.

CHAPTER 1

CHARACTERIZATION OF PAVE PAWS EXPOSURE CONDITIONS

OPERATING CHARACTERISTICS OF PAVE PAWS RADAR SYSTEM AS RELATED TO HUMAN EXPOSURE

"PAVE PAWS" is the name used by the U.S. Air Force for a fixed-base solid-state radar system that includes two radars of identical design-- one at Otis Air Force Base on Cape Cod, Massachusetts, scheduled to go into operation in April 1979, and another at Beale Air Force Base in California, scheduled to go into operation a year later. The radar at Otis Air Force Base is the subject of this report.

This section describes the operating characteristics of the PAVE PAWS radar system, not in the context of engineering and electronic detail, but with reference to how the characteristics are related to human exposure to the radar. In several instances, to provide a familiar reference source, there are comparisons with frequency-modulated (FM) radio broadcast-station operating conditions.

The primary function of PAVE PAWS is the early detection of the approach of ballistic missiles launched from submarines or ships. During normal operation, the radar scans near the horizon across the sector of potential approach. It is designed with the power and sensitivity to detect a launch booster as it appears above the horizon. Once detected, the launched object is continuously tracked and its trajectory estimated. Any object that separates from a booster, as a missile would, is tracked as it approaches. A secondary function of PAVE PAWS is to track satellites as part of the National Space Track net.

Information about objects that are classified as threatening on the basis of their trajectories and expected points of impact is transmitted to the North American Air Defense complex in Cheyenne Mountain, Colorado, to the Strategic Air Command in Omaha, Nebraska, and to the National Military Command Center and Alternate National Military Command Center.

PAVE PAWS is a phased-array radar, whose radiation is emitted from a mechanically fixed antenna, rather than from an antenna that scans or is pointed by being moved. The antenna consists of an array of many small radiating elements. The radiation beam is focused and pointed in a desired direction by controlling the manner in which the individual elements radiate.

If the beam is to be pointed to the left of straight ahead (or "boresight"), the signals from the elements on the left side of the array are delayed relative to those emitted from the elements on the right, with the delay increasing progressively across the array from right to left.

The radar, housed in a triangular building, has two antenna faces, which face in directions 120° apart, as shown in Figure 1. At the Otis site, the two boresight directions are 47° true north and 167° true north. The radar scans the sector from 347° (13° west of north) to 227° (47° west of south). Each antenna face is tilted back by 20°, so that the boresight line tilts 20° above the horizontal.

Only one antenna face transmits at a time. In the normal search operation, the beam scans in a stepwise manner in a somewhat regular sequence across the sector of view, at 3° above the horizon. Free time during a search operation is used to direct the beam to any targets that are under track. Targets under track can be anywhere in the horizontal sector of search and from 3° to 85° above the horizon. The actual pattern of beam positions followed during any one scanning and tracking cycle depends on the particular search mode that has been selected and on the positions of the targets being tracked.

Each face of the antenna is a metal plane from which a regular array of 5,353 antenna elements protrude, as shown in Figure 2. Of these 5,353 elements, 2,676 around the periphery are totally inactive; they would make it possible to increase the size of the antenna and the power of the radar. The 2,677 active elements in the central region of each array constitute the present antenna proper--each antenna face is approximately 72 ft (22 m) in diameter. Of the elements in each face, 1,792 are active transmitting elements; each is connected to a solid-state transmitter (and receiver) module. The remaining 885 electrically active elements in each face are not connected to power sources and serve only to improve control of the shape of the beam.

In normal operation, the PAVE PAWS beam is not directed below an elevation of 3° above the horizon. At Otis Air Force Base, the radar is on high ground, and the main beam of the antenna is always at least 100 ft (30 m) above ground level at the nearest points of public access. In an analysis of public exposure to PAVE PAWS radiation, then, the questions that bear on the radar's performance are:

- o In normal operation, what are the nature and intensity of the radiation that "spills over" to the ground from the axis of the beam?

- o Can abnormal conditions, such as rain, unfavorably affect the shape of the beam or the intensity at ground level?

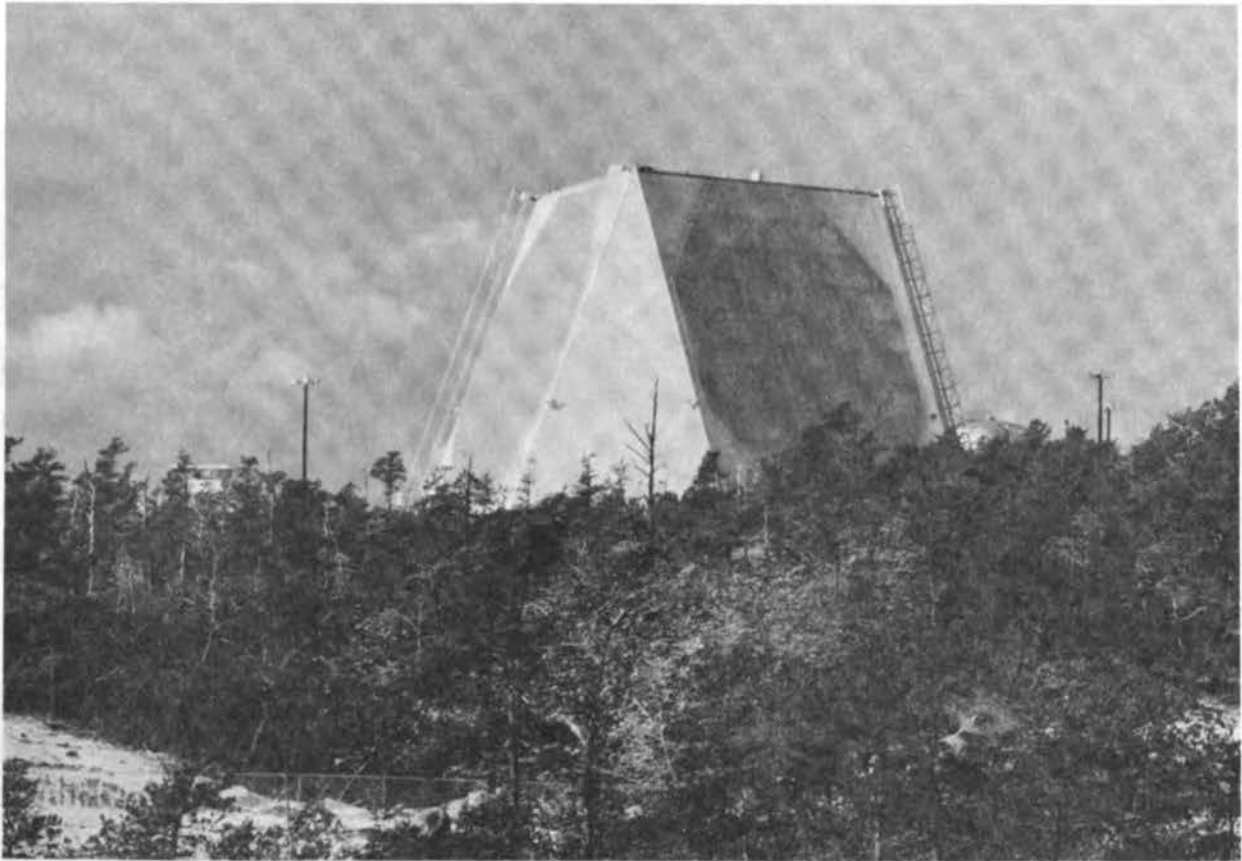

FIGURE 1. PAVE PAWS radar, showing triangular structure and the two antenna faces.

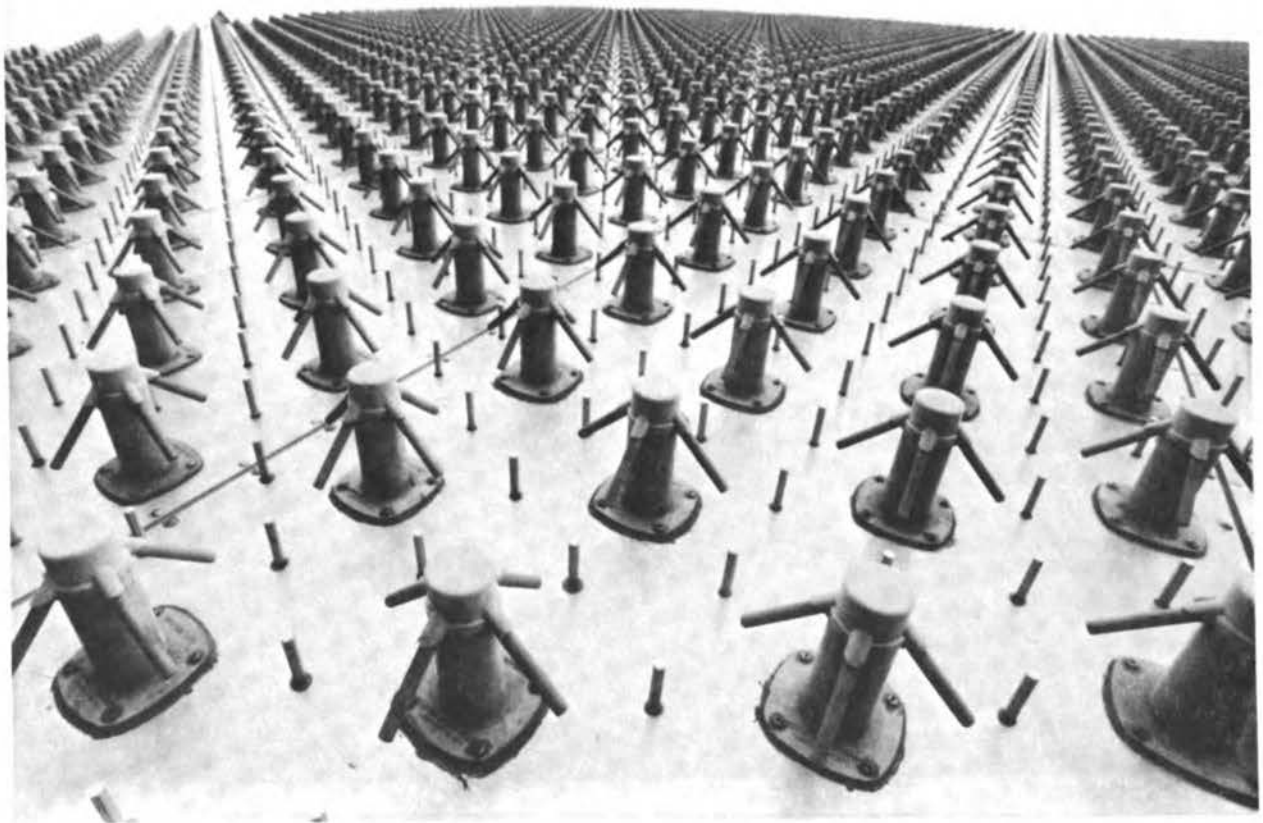

FIGURE 2. Regular array of antenna elements protruding from one face of PAVE PAWS radar.

o What safety features can detect abnormal operation or prevent inadvertent focusing of the beam below the normal 3° minimum?

The shape of the antenna beam in normal operation has been determined by theoretical and computational analysis, and predictions of exposure levels derived from this analysis can be verified by measurements in situ. A panel of the National Research Council Assembly of Engineering (AE) has reviewed the antenna design (which is related to the first two questions), the safety features (which are related to the third question), and the Air Force's measurement program.¹¹⁶ The present report describes the general features of PAVE PAWS operation and the radiation fields that may occur in nearby public areas.

FREQUENCY

The radar operates in ultrahigh-frequency (UHF) band. There are 24 frequencies, from 420 to 450 megahertz (MHz), at which transmission may take place. No significant transmitted energy falls outside the band from 420 to 450 MHz. These frequencies correspond to wavelengths of 60-70 cm (23.6-27.6 in.).

POLARIZATION

The transmitted wave is right-circularly polarized.

POWER

A long-range radar like PAVE PAWS operates by transmitting brief pulses of energy or short trains of pulses, followed by longer periods during which the transmitter is off and the receiver is sensitive to returning echoes. The radiated power is described in terms of "peak power" and "average power." Peak power is the rate at which energy is emitted during the period of one pulse; that is, peak power is the energy of one pulse divided by the duration (in seconds) of that pulse. Average power is the time-averaged rate of energy emission over a period that is long compared with the pulse duration. The duty cycle is the fraction of time, on the average, that the transmitter is transmitting. The average power is determined by multiplying the peak power by the duty cycle.

In assessing the effects of radiation, both peak power and average power must be considered. Peak power governs the instantaneous intensity of the electric and magnetic fields induced in or near a body on which radiation impinges. Average power governs the rate at which energy impinges on a body or medium in the field and therefore governs the rate at which heat may be generated or other effects may be produced in an absorbing body or medium.

TRANSMITTED POWER

Each of the 1,792 transmitting elements in each of the two PAVE PAWS antenna arrays is connected to its own transmitter; the combination of element and transmitter is called a "transmitting module." The pulsed output of each transmitter is such that the element radiates at approximately 320 W at peak power. The peak transmitted power of the radar is thus about 580 kW (320 W x 1,792).

The time sequence of pulses transmitted by PAVE PAWS during a given interval depends on the functions being performed and the number of targets being tracked. However, controls limit the rate at which pulses are transmitted, and the duty cycle never exceeds 0.25. Therefore, the average transmitted power never exceeds 145 kW (0.25 x 580 kW). In round numbers, this is about 3 times the average power transmitted by a typical large TV station and somewhat more than the average power transmitted by a typical high-power-output FM broadcast station (but see the discussion of antenna patterns below). The most powerful FM and TV stations radiate more power than PAVE PAWS.

ANTENNA PATTERN

The key to the operation of the phased-array antenna is that, at distances beyond a few hundred feet from the antenna and in all directions that are separated by even a few degrees in angle from the direction in which the beam is pointed, the electromagnetic fields of the individual transmitting elements cancel each other, whereas in directions along the beam the fields add to each other. The detailed structure of the resulting radiation pattern is complex, in that it varies with the precise position in which the beam is pointed and with the transmission frequency. However, the general features of the pattern can be conceptualized and measured.

If one thinks of the antennas as a searchlight, an observer would see the main beam and then numerous secondary beams, called "sidelobes." The sidelobes would be of much lower intensity and would point in directions divergent from that of the main beam. If an observer were to move as little as 1° off the axis of the main beam (i.e., about 90 ft off the axis at 1 mile away, or 17 m at 1 km away), he would observe that the apparent intensity of the searchlight was decreased to half that on the main-beam axis. The main beam would appear to extinguish by the time he moved 2° from the axis.

A typical sidelobe has a shape resembling that of the main beam, but possibly broader. The so-called first sidelobes form a cluster whose direction is close to that of the main beam. Each, on its own axis, has an intensity not more than 1% of that of the main beam. If the observer were 4° off the axis of the main beam, even the first sidelobes would all be extinguished. Beyond the cluster of the first

sidelobes, there are other sidelobes of lower intensity, none having more than 0.1% of the intensity of the main beam.

RADIATION AT GROUND LEVEL

Where the main beam of PAVE PAWS is pointed to 3° or more above the horizon, the maximum of the radiation field at or near ground level is governed by the sidelobes of the antenna pattern other than the first sidelobes. This field is therefore limited in intensity to 0.1% or less of the intensity of the main beam. At 0.1%, the radiation field corresponds to that which would be observed from a 1,000-kW transmitter radiating uniformly in all directions.

An observer on the ground, situated exactly in the direction of peak intensity of one of the secondary sidelobes, would be exposed to radiation at no more than 0.1% of the intensity of the main beam. Peaks of this intensity are necessarily distributed very sparsely over all angles, because most of the 145 kW of average transmitted power is designed to radiate along the direction of the main beam. Only a small fraction is left to radiate in other directions. Thus, over all angular positions remote from the main beam, the antenna output is similar, on the average, to a source whose average power is only a minute fraction of the maximal intensity of a secondary sidelobe, as estimated above.

In normal operation, the main beam of the antenna is directed sequentially to many different directions even during a fraction of a second, and transmissions occur at different frequencies. This has the effect, of altering from pulse to pulse the sidelobes to which an observer at ground level may be exposed. The average exposure of this observer therefore tends to be comparable with that encountered at an "average" angular position remote from the main beam. Both calculations and measurements on the PAVE PAWS antenna indicate that the average power at ground level near PAVE PAWS should be no greater than one-fifth to one-fourth of the maximum at the peak of a secondary sidelobe.

With respect to average radiation intensity at nearby points on the ground, the PAVE PAWS radar can therefore be regarded as a source radiating isotropically at an average power not greater than 250 kW (0.25 x 1,000 kW), which is comparable with the power of the most powerful FM and TV broadcast stations. Furthermore, these broadcast stations use antennas that concentrate radiation near the horizon, to serve the intended listening areas better. Radiation intensity in a listening area is therefore greater than that received from an isotropic source of the same power.

The PAVE PAWS radar operates at a wavelength about one-fifth that of an FM station or of TV stations on channels 1-6, about the same as that of UHF TV stations, and about twice that of TV stations on channels 7-13.

PAVE PAWS and other types of radar radiate energy in short pulses of high peak power, creating a signal that is very different from that of an FM or TV station. The nature of radar signals is examined further below.

MODULATION

The pattern of pulses emitted by the PAVE PAWS radar can be quite complex, because it depends on the number of targets being tracked, the distances of the targets from the radar, and the region being searched for targets. There are, however, some regularities.

The operations of the radar are timed to a basic cycle of 0.054, or 54 milliseconds (ms). During one such cycle, several pulses may be transmitted in different directions and at different frequencies. The pattern of one cycle need not, in general, be repeated exactly in the next cycle or in any cycle occurring soon after. There are several basic kinds of cycles, called "templates." In one template, all the pulses are transmitted during the first 16 of the 54 ms. The other templates correspond to division of the 54-ms cycle into two, four, or eight sub-cycles, scaling down the transmitting period in each subcycle to 8, 4, or 2 ms. Every eighteenth cycle of operation is dedicated to testing and calibrating the radar. There tends to be some regularity in the manner in which the templates alternate or repeat from cycle to cycle.

The resulting signal, which is thus rather random, has elements of a repetitive character at periods of 54, 27, 13.5, and 6.75 ms. These repetition periods correspond to modulating tones at frequencies of about 18.5, 37, 74, and 148 Hz. In addition, sidelobe energy received at any point on the ground is subject to further modulation, because the successive pulses are typically transmitted in different directions and at different frequencies. This results in low-frequency components (2 Hz and below) in the modulation and in the spreading of energy about the concentrations at 18.5 Hz and its harmonics.

RADAR CONTROL

The detailed pattern of operation of PAVE PAWS radar is controlled by computers that are integral parts of the system. Signals received by the radar are processed and interpreted by a central computer. The results are displayed to operators and are made available for further processing and for transmission to users of the data.

Under general conditions of operation that are selected or set by entering instructions into the central computer through an operator's keyboard, the central computer and a radar-control computer generate beam-steering orders and transmitting orders for each 54-ms cycle of

transmission and reception. The beam-steering orders appear as electric signals unique for each of the 1,792 transmitter-receiver modules. Each module delays the transmitting or receiving of signals as directed by the instructions from the computer. In the transmitting mode, the transmitter-receiver module acts simply as an amplifier (with an appropriate delay) for whatever pulse it has been directed to transmit.

In this control process, there are, at least in principle, a number of ways in which the cycle of normal operation could be in error. Errors that could affect exposure estimates are the following kinds:

- o A well-formed beam might be steered to an angle below the 3° limit, and reflection from the ground might increase the power density.
- o A poorly formed beam might have sidelobes more intense than those described.
- o Transmission might occur at a duty cycle greater than 0.25.

In the estimates previously referred to, it was noted that in areas of public access, under normal radar operating conditions, an observer could be exposed to the sidelobes of a rapidly scanning antenna, and that, on the average, the radiation intensity would be much less than that estimated for the peak of a secondary sidelobe. There is, therefore, a fourth possible effect:

- o A well-formed beam, properly steered, might remain stationary, rather than operating in a continuously scanning mode. Thus, there could be, at some points in the public area, steady illumination at an average intensity greater than that which would be received from a powerful FM station at the position of the radar.

The safeguards against these malfunctions that are incorporated into the design and testing procedures of the PAVE PAWS radar are the subject of a detailed review, cited earlier, by a panel of the AE. The next section summarizes the relevant portion of that review.

SAFEGUARDS

The four kinds of malfunction noted above might arise from the issuance of improper orders by the computers to the signal-generating and beam-steering circuits of the radar or from improper execution of valid orders by the radar.

Safeguards for both computer and radar operation have been built into the system. First, internal checks in the computer programs are

designed to sense malfunctions of the computer of any kind and specifically to test steering orders for violations of the 3° limit, as well as other limits. Second, there are instruments that monitor, essentially independently, many features of the radar performance and many elements of the radar. Some of these instruments make periodic tests called for by the computer; others measure such quantities as temperature and voltage, independently of the computer.

Displays at the operating consoles summarize the status of the system at all times and warn of minor malfunctions. Serious malfunctions, which result in the sounding of alarms, can shut down the power supply of the transmitters. The system reacts to a major malfunction within a few seconds.

The more important safeguards that are parts of the computer program are discussed in more detail in the report of the AE panel. The following observations are related to the four general kinds of possible malfunctions listed above.

o Beam steered below 3°: Two simultaneous failures would have to occur for a beam to be steered below 3°--one a failure in a program in the central computer, the other a failure in the operation of an entirely separate computer. There are independent guards and monitors against each kind of failure. In the opinion of the AE panel, there appears to be no practical possibility of the simultaneous failures that would result in a beam direction of less than 3° above the horizon.

o Poorly formed beam (severe sidelobe): Generation of a poorly formed beam requires that a number of antenna elements radiate essentially in a cooperative manner, like a separate small antenna that has been steered in an improper direction. For example, doubling the intensity of one of the secondary sidelobes of the normal antenna requires that about 50 individual radiating elements, properly spaced in the whole array, exhibit improper signal delays in a systematic way. In the opinion of the AE panel, the manner in which steering orders are generated and distributed to the individual transmitting modules makes such a malfunction extremely unlikely. In any case, monitors of the radar's operation would detect such a malfunction within 30 s. Because there are as many as 1,792 transmitting elements, a few random failures of individual elements to transmit properly or to execute steering (delay) orders properly would result in only a small distortion of the antenna-beam pattern. At every eighteenth radar cycle, essentially once each second, the computer interrupts the operation of the radar and puts groups ("subarrays") of 32 transmitting modules each through tests of response to steering orders. Performance is observed by a test monitor mounted on a pole approximately 100 ft (30 m) in front of the antenna

face. The existence of a malfunction of any kind is displayed on a maintenance console, and the malfunctioning subarray is shut down automatically. The entire cycle of antenna operations is tested every 30 s. Antenna elements that are electrically damaged--for example, by ice or snow--would be detected by these same antenna tests. Heating elements in the antenna face prevent icing and the accumulation of snow.

o Excessive transmitting power: Quite apart from checks within the computer software, there are monitors of temperature and of other indicators of power-supply overload that are designed to shut the system down under overload conditions. Even if it were possible for transmission at a duty cycle of 0.30 s to be called for, the system would shut down in a matter of seconds.

o Beam not scanning: When the beam is properly pointed, at more than 3° above the horizon, failure of the beam to scan would result in exposures no greater than the maximum estimated earlier. As a safeguard, when the beam is under control of the central computer, an alarm sounds if more than 16 consecutive pulses are emitted in the same direction. When the beam is under manual control, transmission is prevented by the radar-control computer if the angle of elevation is less than 6°.

WEATHER EFFECTS

Rain and fog can scatter electromagnetic radiation. At UHF wavelengths, the effect of scattering is not significant. Traveling through many miles of rain or fog, the beam loses a few percent of its total energy (much of the loss by absorption, rather than by reradiation or scattering). Therefore, in the neighborhood of the radar, the energy scattered to the ground by rain, fog, or snow is a minute fraction of that already accounted for in the sidelobe calculations above.

An anomalous distribution of temperature in the atmosphere can refract (bend) the radar beam. Even under worst possible atmospheric conditions, the amount of bending is so small that it does not affect the radiation environment described here.

MEASURED AND CALCULATED POWER DENSITIES OF THE PAVE PAWS RADAR

This discussion is limited to a review of three studies that are directly applicable to the prediction of electric fields and power densities produced by PAVE PAWS at locations outside the boundaries of Otis Air Force Base. The first gives results of measurements in August 1978 on Otis Air Force Base in front of the south face of the radar with only the south face operating.¹²¹ The second gives results of measurements in October 1978 outside the base boundaries with both the north and south faces of the radar operating.¹²² The third is an

analytic study.⁷⁵ Other measurements have been made, but most of these were for testing the operation of the radar,¹²⁰⁻¹²² not for measuring the environmental fields.

MEASUREMENT METHOD

The system used by the Air Force for measuring peak electric-field strength and average power density is shown in Figure 3.¹²¹ Peak power density was calculated from the measured peak electric field strength. According to the Air Force, this system has been reviewed by the National Bureau of Standards (NBS).¹²¹ The calibration of the system is traceable to NBS, and the overall uncertainty is determined by dividing and multiplying the measured values of field strength and power density by 1.6.

At each measurement location, a dipole antenna on a tripod was raised to a height of 2 m. The antenna was moved horizontally to locate a maximal value, and the received signal was measured in three orthogonal planes.¹²¹

A Singer NM-37/57 field-intensity meter was used to measure the peak electric-field strength, and the data were processed by a small computer and recorded on magnetic tape at a rate of 50 samples per second in August and 100 samples per second in October. Average power density was measured with a Hewlett-Packard 8484A power sensor and a 436A power meter sampled by the computer at a rate of 167 samples per second in August and 100 samples per second in October.

RESULTS

The peak electric-field strength and the average power density were measured at four locations in front of the south face of the radar on August 26, 1978. The south face was operated at a frequency of 435 MHz, a duty factor of 0.2, and normal power (nominal average, 146 kW). At three of the four sites, data were collected for beam elevations of 3°, 6°, and 10°; only 3° and 6° data were collected at the fourth site. At each elevation, the beam scanned back and fourth. The results, taken from PAVE PAWS System Program Office¹²¹ and arranged in order of increasing distance are given in Table 1. Although only the south face was operating, all four sites were within 3,900 ft (1,190 m) and 63° of boresight for the south face, and the measured values should be close enough to those obtained when both faces are operating to permit valid comparisons between measured and predicted values.

Similar measurements were made at 21 sites in Bourne, Sandwich, Mashpee, and Falmouth, Massachusetts, on October 20 and 21, 1978. The operating conditions were as described above, except that both the north and south faces were operating with a duty factor of 0.18. Measurements were made for 3°, 6°, and 10° of radar-beam elevation,

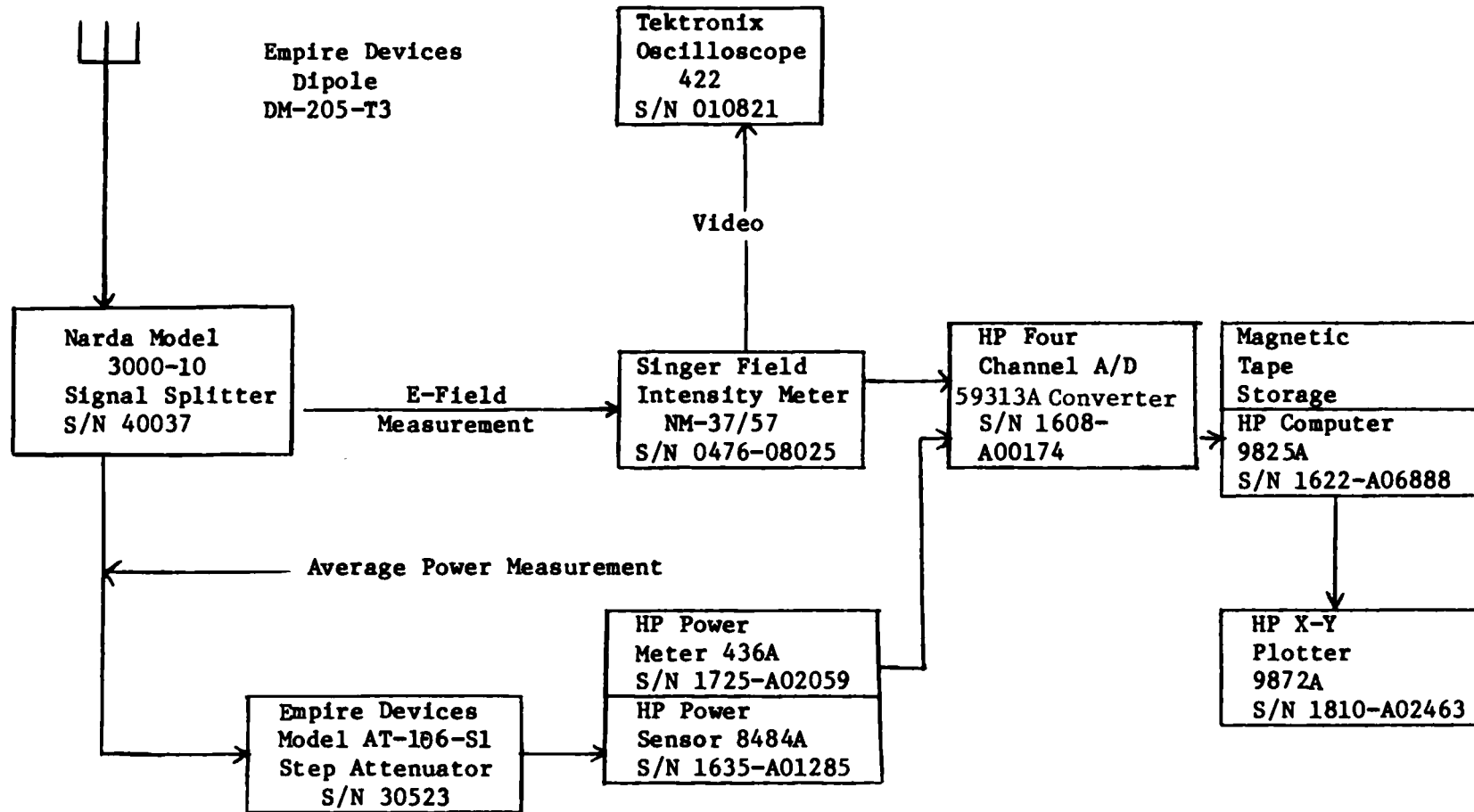

FIGURE 3. Test Instrumentation.

TABLE 1

Results of Measurements of Electric-Field Intensity and Power Density
Produced by South Face of PAVE PAWS Radar, August 26, 1978^a

Measurement Location					Beam Elevation, Degrees	Peak ^c Electric Field, V/m	Power Density		Ratio of Peak to Average Power Density
Distance		Elevation		Angle ^b			$\mu\text{W}/\text{cm}^2$		
ft	m	ft	m	Degrees		Peak ^d	Aug		
1,600	490	258	79	9	3	36	344	2.86	120
					6	23.8	150	3.26	46
					10	26	179	2.90	62
1,800	550	230	70	63	3	17.5	81	1.71	47
					6	16.5	72	1.21	60
					10	12.5	41	1.11	37
3,100	945	274	84	12	3	20.2	108	0.87	124
					6	14.6	57	0.37	154
					10	7.8	16	0.41	39
3,900	1,190	250	76	0	3	13.4	48	0.38	126
					6	8.1	17	0.20	85
					10	--	--	--	--

^aData from PAVE PAWS System Program Office.¹²¹

^bAzimuthal angle from boresight.

^cRoot-mean-square (rms) value; multiply by $\sqrt{2}$ and 2 to obtain instantaneous values of electric-field strength and power density, respectively.

^dCalculated from corresponding value of rms peak electric-field strength according to $S(\mu\text{W}/\text{cm}^2) = [E^2(\text{V}/\text{m})^2/377(\Omega)] \times 10^2$.

but only 3° data were recorded. The results, reproduced from PAVE PAWS System Program Office,¹²² are given in Table 2. Table 3 shows the same data arranged in order of distance and includes the ratios of peak power to average power.

Hankin has calculated the electric-field strength and average power density expected to be produced by the radar.⁷⁵ Hankin's data are reproduced here as Table 4. Locations 4 through 22 lie outside the boundaries of Otis Air Force Base. Of these 19 sites, four correspond roughly to sites where the Air Force took measurements; the results for these four sites are compared in Table 5.

As examination of the data in Tables 1-5 leads to two conclusions: the average power density produced by the radar at locations outside the boundaries of Otis Air Force Base is not likely to exceed $1 \mu\text{W}/\text{cm}^2$ near the base boundaries and will be even less at more distant locations, and the ratio of peak to average power density is between 37 and 320.

The point nearest to the radar that lies outside the base boundaries is along U.S. Route 6. The calculated and measured values (Table 5) of the peak electric-field strength are in good agreement for this location and in reasonably good agreement with the data in Table 1 for distances of 3,100 and 3,900 ft (945 and 1,190 m). The average power densities do not agree as well, but they are not inconsistent. In computing averages, Hankin assumed that the sidelobe exposure was never less than the maximal value of a secondary sidelobe, i.e., less by a factor of 1,000 than the main-beam exposure at an equivalent distance. However, this, in effect, assumes a stationary beam. If one accounts for the motion of the beam, the average should be lower by about a factor of 6.3 than the stationary average value, or lower by a factor of 6,300 than the main-beam exposure at an equivalent distance.¹²² If Hankin's calculated value of $4.7 \mu\text{W}/\text{cm}^2$ is reduced by a factor of 6.3, the result, $0.75 \mu\text{W}/\text{cm}^2$, is about the same as the measured values at distances of 3,100 and 3,900 ft (see Table 1)—between 0.2 and 0.87 for various ratios of peak to average power. These values are still about an order of magnitude greater than the average power density measured at the Route 6 site (see Table 2).* The data in Tables 3 and 4 show that, in general, exposure decreases with distance from the site, but not uniformly; that, far from the source, measured values decrease more rapidly than calculated values, presumably because calculations do not take into account attenuation by the atmosphere, trees, etc.; and that the ratio of peak to average power density varies widely and, from the limited data in Tables 1 and 3, appears to depend on beam elevation, azimuthal angle, and distance from the source. The following paragraphs show that the observed range of the ratio of peak to average power density is consistent with assumptions generally made. However, the data in Tables 1 and 3 are too limited to uncover any particular trends or patterns.

*At approximately equivalent distances from the radar source, measurements may differ because of ground topology and other factors.

TABLE 2

Results of Measurements of Electric-Field Intensity and Power Density
of PAVE PAWS Radar with Both North and South Faces Operating at a
Beam Elevation of 3°, October 20-21, 1978^a

Test Point	Location	Approximate Distance		Peak (rms) Electric Field, V/m	Power Density $\mu\text{W}/\text{cm}^2$	
		Miles	km		Peak	Average
1	Rest area, Route 6	0.6	1.0	8.57	19.5	0.061
2	Shawme and Shaker House Roads	2.1	3.4	3.18	2.7	0.027 ^b
3	Henry T. Wing School	2.1	3.4	0.46	0.055	^b
4	Dillingham and Knott Roads	2.4	3.9	3.70	3.6	0.02
5	Sandwich High School	4.4	7.1	0.42	0.047	0.001 ^b
6	Entrance, Lakewood Hills Development	4.6	7.4	0.15	0.006	^b
7	Knolltop and Greenhouse Roads	5.4	8.7	0.31	0.026	^b
8	Mashpee Police Department	7.3	11.7	0.09 ^b	0.002 ^b	^b
9	Mashpee Middle School	9.2	14.8	^b	^b	^b
10	Seabury Golf Club	13.8	22.2	0.09	0.002	^b
11	Sagamore Bridge	1.6	2.6	4.44	5.23	0.051
12	Canalside Apartments	2.0	3.2	2.79	2.07	0.016
13	Hoxie Elementary School	1.7	2.7	0.89	0.209	0.001
14	Old Plymouth Road	2.8	4.5	0.84	0.188	0.002
15	Hilltop Drive (Maiolini residence)	1.0	1.6	1.14	0.345	0.003
16	Kieth Field	1.4	2.3	0.17	0.008	^b
17	Stone School, Otis Air Force Base	7.1	11.4	0.08	0.002	^b
18	Ashumet Development, Hatchville	8.8	14.2	0.09	0.002	^b
19	Benthos Corp.	8.9	14.3	0.06 ^b	0.001 ^b	^b
20	North Falmouth Elementary School	9.0	14.5	^b	^b	^b
21	Falmouth High School	11.8	19.0	^b	^b	^b

^aData from PAVE PAWS System Program Office. 122

^bBelow reportable value (less than 0.001 $\mu\text{W}/\text{cm}^2$).

TABLE 3

Ratio of Peak to Average Power Density (Based on Table 2)

Test Point	Approximate Distance		Power Density $\mu\text{W}/\text{cm}^2$		Ratio of Peak to Average Power Density
	Miles	km	Peak	Average	
1	0.6	1.0	19.5	0.061	320
15	1	1.6	0.345	0.003	115
16	1.4	2.3	0.008	a	--
11	1.6	2.6	5.23	0.051	103
13	1.7	2.7	0.209	0.001	209
12	2.0	3.2	2.07	0.016	129
2	2.1	3.4	2.7	0.027	100
3	2.1	3.4	0.055	a	--
4	2.4	3.9	3.6	0.02	180
14	2.8	4.5	0.188	0.002	94
5	4.4	7.1	0.047	0.001	47
6	4.6	7.4	0.006	a	--
7	5.4	8.7	0.026	a	--
17	7.1	11.4	0.002	a	--
8	7.3	11.7	0.002	a	--
18	8.8	14.2	0.002	a	--
19	8.9	14.3	0.001	a	--
20	9.0	14.5	a	a	--
9	9.2	14.8	a	a	--
21	11.8	19.0	a	a	--
10	13.8	22.2	0.002	a	--

^aBelow reportable value (less than $0.001 \mu\text{W}/\text{cm}^2$).

TABLE 4

Predicted Values of Electric-Field Intensity and Power Density
for PAVE PAWS Radar^a

Test Point	Location	Distance		Power Density, Moving Beam, μ W/cm ²	Peak Electric- Field Intensity, V/m
		Ft	km		
1	Gibb's Road, along 227° radial	2,190	0.7	16	16
2	Route 25: closest to antenna	2,690	0.8	11	13
3	along 347° radial	2,890	0.9	9.3	12
4	U.S. 6 : closest to antenna	3,450	1.1	6.5	9.9
5	north	4,180	1.3	4.4	8.1
6	east	5,640	1.7	2.4	6.0
7	Sandwich: nearest housing	5,200	1.6	2.9	6.6
8	camping area	5,380	1.6	2.7	6.4
9	housing	6,180	1.9	2.0	5.5
10	housing	6,380	1.9	1.9	5.4
11	camping area	6,575	2.0	1.8	5.2
12	housing	8,370	2.6	1.1	4.1
13	Sagamore: nearest housing	5,780	1.8	2.3	5.9
14	Sagamore Bridge	8,370	2.6	1.1	~11
15	Sagamore School	9,460	2.9	0.9	3.6
16	Canal View Road, 227° radial	15,480	4.7	0.3	~4.8
17	Pine Hill Tower	17,733	5.4	0.2	~5.1
18	Telegraph Hill Tower	15,940	4.9	0.3	~5.2
19	Otis structures	25,500	7.8	0.1	~3.5
20	Otis structures	29,500	9.0	0.09	~3.0
21	North Pocasset	26,100	8.0	0.1	~3.2
22	Otis schools	36,500	11.1	0.06	~2.4

^aData from Hankin.⁷⁵

TABLE 5

Comparison of Calculated and Measured Values

Location	Approximate Distance		Peak Electric Field, V/m		Average Power Density, $\mu\text{W}/\text{cm}^2$		
	Ft	km	AF ^a	Calculated ^b	AF ^a	Calculated ^c	Calculated ^d
Closest boundary, Route 6	3,450	1.1	8.6	8.4	0.06	4.7	0.75
Sagamore Bridge	8,370	2.6	4.4	9.3	0.05	0.8	0.13
Sagamore School (Hoxie Elementary)	9,460	2.9	0.89	3.1	0.001	0.65	0.10
Otis School (Stone)	36,500	11.1	0.08	2.0	<0.001	0.04	0.006

^aAir Force measurement data.

^bData from Table 4 multiplied by $\sqrt{18/25}$ to adjust for differences in duty factor.⁷⁵

^cData from Table 4 multiplied by $18/25$.⁷⁵

^dData reduced by a factor of 6.3 to take beam motion into account.⁷⁵

CALCULATION OF RATIO OF PEAK TO AVERAGE POWER DENSITY

Consider the power density, $\langle S \rangle$, produced at a point in space by a scanning radar. We assume that the point is illuminated each time the source is pulsed. The pulse amplitude will depend on the sidelobe structure of the antenna and the position of the beam. In Figure 4, this is depicted as a series of pulses with monotonically decreasing amplitudes. For simplicity, we assume that all pulses have the same width, σ , and period, τ , and that the scan is periodic with period $\eta\tau$ where η is the number of pulses per scan. The time-averaged power density, $\langle S \rangle_t$, is given by:

$$\langle S \rangle_t = (1/\eta\tau) \int_{t=0}^{t=\eta\tau} S dt \quad (1)$$

$$= (1/\eta\tau) \sum_{i=1}^{\eta} \sigma S_i ;$$

$$= \alpha [(1/\eta) \sum_{i=1}^{\eta} S_i], \quad \alpha = \sigma/\tau. \quad (2)$$

Without loss of generality, we assume $S_1 > S_{i+1}$ for all i . We further assume that there is no exposure to the main beam. Hence, let S_1 be the power density associated with primary sidelobe, S_2 that associated with the secondary sidelobe, etc. We then take the following two quantities as given:

$$S_2/(1/\eta \sum S_i) = 6.3, \text{ i.e., } 8\text{dB (ref 122)}; \quad (3)$$

$$S_1/S_2 = 10 \text{ (ref 75)}. \quad (4)$$

If there is no exposure to the primary sidelobe, then $S_1 = 0$, and the ratio of the peak power density, S_p , to the time average is given by

$$(S_p/\langle S \rangle_t) = (S_2/\langle S \rangle_t) = S_2/\alpha [(1/\eta) \sum S_i] \quad (5)$$

$$= 6.3/\alpha$$

$$= 35 \text{ for duty factor } (\alpha) \text{ of } 0.18.$$

If the first sidelobe is present, then from Equation 4:

$$(S_p/\langle S \rangle_t) = S_1/\langle S \rangle_t = 10 S_2/\langle S \rangle_t \quad (6)$$

$$= 350 (\alpha = 0.18).$$

Therefore, the ratio of peak to average power density lies in the range

$$35 \leq [S_p/\langle S \rangle_t] \leq 350,$$

for a duty factor of 0.18.

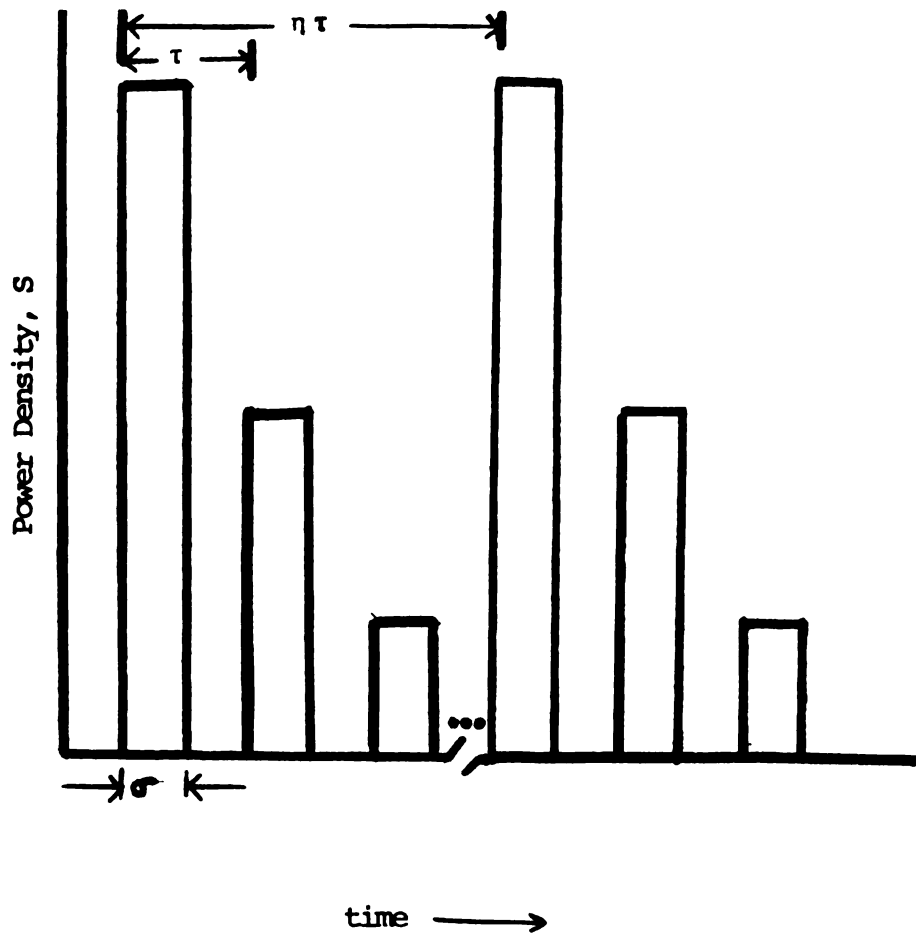

FIGURE 4. Schematic representation of pulses from a scanning radar

POPULATION EXPOSED TO PAVE PAWS RADIATION

The estimated number of persons living in the vicinity of the PAVE PAWS antenna is shown in Table 6. It should be understood that Cape Cod's transient summer population is greater than indicated by the numbers in the table. It is evident that there is little or no population within 1 mile (1.6 km) of the antenna site.

TABLE 6

Distribution of Population around PAVE PAWS
Radar Site, Otis Air Force Base, Massachusetts^a

<u>Radius^b</u>		<u>No. Census</u>	<u>No. Housing</u>	<u>Population</u>
<u>Miles</u>	<u>km</u>	<u>Enumeration</u>	<u>Units</u>	
		<u>Districts</u>		
1	1.6	0	0	0
5	8.0	2	916	1,239
10	16.1	19	8,059	11,235
20	32.2	88	28,195	63,289

^aThe population data base from which this table was prepared is an edited and compressed version of the 1970 U.S. Bureau of the Census Master Enumeration District List with Coordinates. The computer program and data base were adapted from those developed primarily for marketing purposes by the U.S. Department of Commerce.⁴⁴ The population data base contains the housing and population counts for each census enumeration district (CED) and the geographic coordinates of the population centroid for the district. In the Standard Metropolitan Statistical Areas, the CED is a "block group," which usually consists of a city block. In other areas, the district is called an "enumeration district," and it may cover several square miles in areas of low population density, as in the case of the PAVE PAWS site. There are approximately 250,000 CEDs in the United States, and the average population is about 800. The positions of the population centroids for each CED were marked on the district maps by the individual census officials responsible for the districts and are based only on their judgment from inspection of the population distribution on the maps. The resolution of the data base as applied to the PAVE PAWS site allows confident estimation of population for distances somewhere between 5 and 10 miles (8 and 16.1 km) from the site. Population figures for shorter distances should be viewed only as estimates.

^bPAVE PAWS coordinates, 70°32'18" West, 41°45'11" North.

ENVIRONMENTAL LEVELS OF RADIOFREQUENCY RADIATION

The entire population of the United States is exposed to radiowaves, including microwaves, from a variety of communication, medical, industrial, and consumer-product sources--e.g., radio and television broadcast systems, radars, radiotelephones, citizen's band radio, microwave relay links, medical diathermy units, radiofrequency heat sealers, and microwave ovens for industrial and home use. The discussion here is limited to sources that produce readily detectable radiofrequency radiation in locations that are accessible to the general population and does not treat occupational or medical exposure.

It is convenient to define two kinds of environmental radiofrequency exposure. One occurs at distances far from individual sources and is due to the superposition of the fields from many sources operating at different frequencies; in the discussion that follows, we call this the "general radiofrequency environment." In a relative sense, whether exposure in the general environment is high or low may depend on the locations and types of sources that contribute to the exposure. The other kind of exposure, actually a special case of the first, occurs so close to a particular source (or sources) that the radiowave environment is dominated by the source(s) at that location; we call this the "specific-source radiofrequency environment."

The quantity most commonly used for specifying exposure to radiowaves is power density. Power density is the rate at which energy crosses a unit area; in the International System of Units, it is given in watts per square meter (W/m^2). In temperate latitudes on a cloudless day, the rate at which sunlight falls on the earth's surface is about $1,000 W/m^2$. For historical reasons, radiofrequency exposure is often expressed in milliwatts (mW) or microwatts (μW) per square centimeter (cm^2). The interrelationships among these units are shown in Table 7.

TABLE 7

Units of Radiowave Power Density

<u>W/m^2</u>	<u>mW/cm^2</u>	<u>$\mu W/cm^2$</u>
0.01	0.001	1
0.1	0.01	10
1	0.1	100
10	1	1,000
100	10	10,000

GENERAL RADIOFREQUENCY ENVIRONMENTS

Broadcast Sources

The urban general radiofrequency environment is dominated by radio and television broadcast transmissions.^{8,79,80,152,154} On the basis of measurements made at 373 locations (about 30 in each of 12 cities) with a total 1970 population of over 38 million, it is estimated that the median continuous exposure in urban areas of the United States is $0.005 \mu\text{W}/\text{cm}^2$, i.e., 50% of the population is exposed to higher power densities and 50% to lower.¹⁵² The results of these studies, shown in Tables 8 and 9, indicate that 95% of the population is exposed to less than $0.1 \mu\text{W}/\text{cm}^2$ and that less than 1% may be exposed to greater than $1 \mu\text{W}/\text{cm}^2$. These estimates do not include contributions from AM radio transmission; the absorption of energy at AM broadcast frequencies (0.535-1.605 MHz) by humans is less than the absorption of energy at FM and TV frequencies (54-890 MHz) by several orders of magnitude.¹⁴⁷ Nor do these estimates include such refinements as accounting for population mobility, for exposures at heights greater than 6 m (20 ft), for attenuation by typical buildings, or for periods when sources are not transmitting. The estimates are based simply on the population that resides in areas more than several hundred feet from FM and TV broadcast antennas where an unobstructed measurement 6 m above the ground would result in the indicated values.⁸

Nonbroadcast Sources

For a number of reasons, the nonbroadcast sources do not appear to contribute significantly to the general radiofrequency environment, although the contribution of the higher-powered devices to specific-source environments may be large. Examples of low-power devices include microwave relay links, personal radios (such as radiotelephones and citizen's band radios), and the traffic radars used by law-enforcement agencies for measuring the speed of vehicles. Examples of higher-power nonbroadcast sources include satellite communication systems and radars (including military acquisition and tracking radars), civilian air-traffic control and air-route surveillance radars, and weather radars. Because all these high-power systems use highly directive antennas, they form beams with small cross sections; thus, only a small volume of the available space is irradiated at any given time. For many of the systems, the beam is high above the ground or the antenna is angled 2° to 3° above the horizon, so the possibility of exposure to the main beam is severely limited. Most radar systems rotate, and that further reduces the average exposure. Table 10 summarizes the measurements made in one large urban area.¹⁴⁶ The highest observed average power density was $0.001 \mu\text{W}/\text{cm}^2$.

TABLE 8

Population Exposure in 12 U.S. Cities,
54-900 MHz^a

<u>City</u>	<u>Median Exposure,</u> <u>$\mu\text{W}/\text{cm}^2$</u>	<u>Percent of Population</u> <u>Exposed at $<1 \mu\text{W}/\text{cm}^2$</u>
Boston	0.018	98.50
Atlanta	0.016	99.20
Miami	0.007	98.20
Philadelphia	0.007	99.87
New York	0.002	99.60
Chicago	0.002	99.60
Washington	0.009	97.20
Las Vegas	0.012	99.10
San Diego	0.010	99.85
Portland	0.020	99.70
Houston	0.011	99.99
Los Angeles	0.005	99.90
All cities	0.005	99.41

^aData from Tell and Mantiply.¹⁵²

TABLE 9

Cumulative Population Exposure
at 54-900 MHz^a

<u>Power Density,</u> <u>$\mu\text{W}/\text{cm}^2$</u>	<u>Cumulative Percent of</u> <u>Population Exposed</u>
0.002	17
0.005	49
0.01	69
0.02	83
0.05	92
0.1	95
0.2	97.5
0.5	99
1.0	99.5

^aData from Tell and Mantiply.¹⁵²

^bFor example, 17% are exposed continuously at less than $0.002 \mu\text{W}/\text{cm}^2$, 69% at less than $0.01 \mu\text{W}/\text{cm}^2$, etc.

TABLE 10

Typical Urban Radar Environments in San Francisco,
California^a

<u>Location</u>	<u>No. Radars Detected</u>	<u>Average Power Density, $\mu\text{W}/\text{cm}^2$</u>
Mt. Diablo	8	0.000026
Palo Alto	10	0.00027
Bernal Heights	10	0.0011

^aData from Tell. 146

SPECIFIC-SOURCE RADIOFREQUENCY ENVIRONMENTS

Broadcast Sources

The antennas used for very-high-frequency (VHF) and UHF TV broadcasting are highly directive, as shown in Figure 5. With such antenna patterns, one would expect power densities at high elevations close to the source to be considerably higher than those found at ground level.¹⁵³ Power densities have been measured in some tall buildings that either support broadcast antennas or are within a city block or so of another tall building that supports a broadcast antenna.^{130,150} Table 11 summarizes the results of most of these measurements. The values range from less than $1 \mu\text{W}/\text{cm}^2$ to $97 \mu\text{W}/\text{cm}^2$ for a location inside a building or $230 \mu\text{W}/\text{cm}^2$ at an unshielded location on the roof of a building. Note that two circumstances are required to obtain these higher values: high elevation and proximity to a high-power antenna. The upper floors of tall buildings far from broadcast antennas are not exposed to power densities that differ substantially (factors of 10) from those near the ground at equivalent distances.

Some FM broadcast antennas have antenna patterns that can produce relatively high power densities at ground level near the antenna tower. In addition to the main antenna lobe (Figure 5), they produce a parasitic or grating lobe that is coaxial with the antenna tower.¹⁴⁹ Power densities near the bases of FM towers typically are $1-10 \mu\text{W}/\text{cm}^2$ (Figure 9 in Athey et al.⁸). However, some types of FM antennas can produce fields of $100-350 \mu\text{W}/\text{cm}^2$ at the tower base in areas that are accessible to transient foot traffic (R. A. Tell, unpublished data). These power densities decrease rapidly with distance from the antenna tower, but densities near a few residences may range from 50 to $100 \mu\text{W}/\text{cm}^2$. In a single unusual, if not unique, case, measured fields near the base of an FM antenna tower were between 1,000 and 7,000 $\mu\text{W}/\text{cm}^2$; exposures in open areas--i.e., not close to conducting structures--did not exceed $2,000 \mu\text{W}/\text{cm}^2$.¹⁵⁵

Nonbroadcast Sources

Because of their number and variety, there is less information on nonbroadcast than on broadcast specific-source environments. For purposes of discussion, it is convenient to distinguish between low- and high-power sources. The distinction is somewhat arbitrary. The convention chosen here is the definition of a high-power source as one that can produce a main-beam power density of $100 \mu\text{W}/\text{cm}^2$ at a distance of 100 m from the source's antenna. This strategem distinguishes these sources from low-power sources that may produce equivalent power densities very close to a source, but not elsewhere.

Low-Power Sources. The three types of low-power sources of interest here are microwave relay links, low-power radar, and mobile communication equipment--radiotelephones, citizen's band radios, hand-held walkie-talkies, etc.

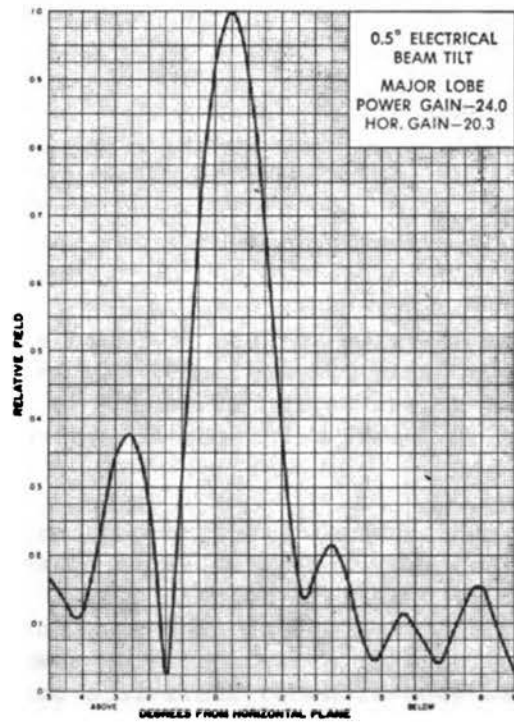

FIGURE 5. Vertical radiation pattern of a UHF TV transmitting antenna.

TABLE 11

Radiofrequency Power Densities in Tall Buildings
Near FM and TV Antennas^a

<u>Location</u>	<u>Power Density, $\mu\text{W}/\text{cm}^2$</u>	
	<u>FM</u>	<u>TV</u>
Empire State Building, New York		
86th-floor observatory	15.2	--
102nd-floor observatory		
Near window	30.7	1.79
Near elevator	1.35	--
World Trade Center, New York		
107th-floor observatory	0.10	1.10
Roof observatory	0.15	7.18
Pan Am Building, New York		
54th floor	3.76	6.52
One Biscayne Tower, Miami		
26th floor	7	--
30th floor	5	--
34th floor	62	--
38th floor	97	--
Roof (shielded location)	134	--
Roof	148	--
Sears Building, Chicago		
50th floor	32	34
Roof	201	29
Federal Building, Chicago		
39th floor	5.7	0.73
Home Tower, San Diego		
10th floor	18	--
17th floor	0.2	--
Roof	119	--
Roof	180	--
Milam Building, Houston		
47th floor	35.8	31.6

^aData from Tell and Hankin.¹⁵⁰

Microwave relay links used for long-distance communication are lower-power devices with transmitter powers usually less than 5 W. The maximal power density in the near-field of the antenna is calculated to be about $700 \mu\text{W}/\text{cm}^2$; except for service personnel, this is not an accessible location. Maximal values at ground level are calculated to be less than $1 \mu\text{W}/\text{cm}^2$ (N. N. Hankin, unpublished data).

The radars used for measuring the speed of vehicles have transmitter powers of about 100 mW. These devices are either hand-held or vehicle-mounted. They are continuous-wave, rather than pulse-modulated, devices and determine speed from the Doppler frequency shift of the returned signal. The maximal calculated near-field power density for typical devices ranges from 170 to $400 \mu\text{W}/\text{cm}^2$ at the face of the device.⁷⁶ Power densities at 3 and 30 m are calculated to be less than 24 and $0.2 \mu\text{W}/\text{cm}^2$, respectively.⁷⁶

Two other low-power radars that are in common use are weather radars in aircraft and navigational radars used on small, pleasure boats. Under normal operating procedures, aircraft weather radars are not operated when the aircraft are on the ground. When they have been operated on the ground, measured power densities for a number of radar-aircraft combinations were less than $10 \text{ mW}/\text{cm}^2$, except on the surface of the radome housing of one system, and less than $1 \text{ mW}/\text{cm}^2$ at distances greater than 3.5 m (11.5 ft).¹⁵¹ For marine radars, the computed average power density for any of the six units that were studied was less than $50 \mu\text{W}/\text{cm}^2$ at the antenna's turning-circle radius;¹²³ one of the units has an option for sector scanning, and the maximal power density was about $250 \mu\text{W}/\text{cm}^2$ when it was operated in this mode.

Most of the information on specific-source environments produced by personal radio devices is based on systems mounted on vehicles or on hand-held walkie-talkies. Interpretation of such data is difficult, because most of the measurements are made in the near-field and the fields are not uniform over volumes comparable with the size of humans; i.e., the reported values are not equivalent to whole-body exposures. Furthermore, the absorption patterns for these complex near-fields may differ appreciably from those produced by far-field whole-body exposures: the absorption may be higher or lower, and the sites of maximal absorption may differ from those in the case of far-field whole-body exposure.

Some measured values for fields in and around vehicles equipped with radios are presented in Table 12 in units of volts per meter (V/m). The values range from a few volts per meter to 475 V/m (Bronaugh *et al.*;²⁴ J. W. Adams, M. Kanda, J. Shafer, and Y. Wu, unpublished data; and D. L. Lambdin⁹²). Only electric fields have been measured. To convert to power density properly, the magnetic fields would also have to be measured, because the impedance in these complex fields is not, in general, 377 ohms (the free-space impedance for a plane wave). Some authors have defined an "equivalent" free-field power density by assuming the impedance value for free space and calculating the power density according to the equation

$$S(\text{W}/\text{m}^2) = E^2(\text{V}/\text{m})^2/377(\Omega) \quad (7)$$

TABLE 12

Electric Field Strength In and Around Radio-Equipped Vehicles

<u>Frequency, MHz</u>	<u>Transmitter Power, W</u>	<u>Vehicle Type</u>	<u>Field Strength, V/m</u>	<u>Reference</u>
27.075	5	Sedan	2-7	24
27.610	80 ^a	Sedan	21-25 ^b	c
40.27	110	Sedan	10-190	c
40.27	110	Sedan	75-368 ^b	c
40.27	110	Tractor-trailer	5-475	c
41.31	100	Compact	5-106 ^d	92
41.31	100	Pickup truck	7-165 ^d	92
162.475	110	Sedan	8-201	c
164.45	60	Sedan	5-52	92
164.45	60	Station wagon	5-64 ^d	92
164.45	60	Van	5-95 ^d	92

^aLegal power is 5 W, assuming 80% efficiency (4 W); illegal power used with special authorization of the Interagency Radio Advisory Committee.

^bVehicle was placed on an electrically grounded plane.

^cJ. W. Admas, M. Kanda, J. Shafer, and Y. Wu, unpublished data.

^dCalculated from the reported electric energy density (U_E), given in the original report from the equation $U_E(\text{nJ/m}^3) = 0.0043E^2(\text{V}^2/\text{m}^2)$, where E is the electric field.

When used in this manner, however, "equivalent" does not necessarily mean equivalent heating power density. If one ignores this complication and performs the calculation, then the range of 2-475 V/m corresponds to an "equivalent" power-density range of 1 μ W/cm² to 60 mW/cm².

Little information is available on the fields produced by hand-held walkie-talkies. In one study, electric fields 12 cm from a 2.5-W hand-held unit operating at 27.12 MHz were measured to be as much as 205 V/m, for an "equivalent" power density of 11 mW/cm².¹³¹ The measured magnetic field was 0.9 A/m, which from Equation 8 is "equivalent" to 31 mW/cm².¹³¹

$$S(\text{W/m}^2) = 377(\Omega)H^2(\text{A/m}^2) \quad (8)$$

Maximal fields of 200 nanojoules per cubic meter (nJ/m³)--212 V/m or 11.9 mW/cm² "equivalent"--have been measured for a 1.8-W hand-held unit operating at 164.45 MHz; the measured exposure rapidly diminishes by a factor of 10 within 1 or 2 in. (2.5 or 5 cm) of the maximal-exposure site.

It was noted earlier that the complex near-fields were not well characterized by power density and that predictions of thermal impact could not be directly extrapolated from far-field whole-body exposures. One study that used dielectric phantom models of human heads predicted temperature increases of less than 0.1°C in the region of the eye for a 6-W, 150-MHz hand-held unit whose antenna was positioned 0.5 cm from the eye.¹⁰ Such techniques have been extended to higher frequencies (Balzano et al.¹⁰ and Balzano, O. Gavay, and F. R. Steel, unpublished data.

High-Power Sources. The principal nonbroadcast high-power sources are satellite communication systems⁷⁴ and the larger radars. The satellite communication systems are continuous-wave sources and the radars are usually pulse-modulated. A study by the Electromagnetic Compatibility Analysis Center in 1972 for the U.S. Environmental Protection Agency identified 223 continuous-wave sources with effective radiated power greater than 1 MW and 375 pulsed sources with peak effective radiated power of 10 gigawatts* (GW) or greater.¹⁴⁸

The main-beam power densities generated by these systems can be greater than 10 mW/cm².^{74,94} However, the environmental significance of specific systems depends on the power densities in locations that are accessible to people. High-power sources use directional antennas to achieve high effective radiated power. The probability of being irradiated by the primary beam of one of these sources is quite small, for three reasons: with the exception of height-finder radars, the primary beam is usually 3° or more above the horizon; many of these sources are remote and are surrounded by an exclusion area that limits access to

*1 GW = 10⁹ W.

the primary beam; and, some sources are mechanically or electrically equipped to limit the pointing direction of antennas or to reduce or shut off power when occupied areas are scanned. Thus, the directional radiation distribution pattern of most high-power sources reduces the probability of human exposure to high-power densities.

Persons who live or work near airports or military bases are exposed to sidelobe radiation from systems with stationary or slowly moving antennas, as well as many types of radar with rapidly moving antennas. Calculated exposures are 10-100 $\mu\text{W}/\text{cm}^2$ at distances of up to 0.5 mile (0.8 km) from some of these systems (N. N. Hankin, unpublished data). The motion of the antennas of acquisition radars reduces the time-averaged power density from these systems. For high-power radars, a combination of mitigating factors, such as beam motion and antenna elevation angle, makes it unlikely that power densities will exceed 50 $\mu\text{W}/\text{cm}^2$ at distances of over 0.5 mile, at least in locations that are accessible to people (N. N. Hankin, unpublished data). The fields produced by these high-power sources have not been evaluated generically. Until further work is done, each high-power source must be evaluated individually.

SUMMARY

Low-power systems--e.g., microwave relay links, low-power radars, and mobile communication systems--contribute the least to environmental radiofrequency radiation. The general radiofrequency environment to which most persons in the United States are exposed is dominated by broadcast transmitters, i.e., radio and television. Approximately 99% of the people who live in metropolitan areas are exposed to radiation at power densities below 1 $\mu\text{W}/\text{cm}^2$; the median exposure is 0.005, $\mu\text{W}/\text{cm}^2$.

Of the low-power sources, only mobile communication equipment produces densities that, at least on cursory examination, appear high. These "equivalent" power densities, calculated on the basis of electric field, do not provide a sufficient basis for evaluating their impact. Other complicating factors include partial-body exposure and the intermittent mode of operation of these devices. More work needs to be done, but the exploratory efforts that have been made indicate that tissue temperature increases should not exceed 0.1°C under conditions of normal operation.

The specific-source radiofrequency environment for most broadcast sources is well below 100 $\mu\text{W}/\text{cm}^2$. The only fields in excess of this occur in the immediate vicinity of a few FM antenna towers and on the roofs of tall buildings within a block or so of FM and TV broadcast antennas. With respect to other high-power sources, such as radars and satellite communication systems, the potential for human exposure to obviously high power densities is small, owing to system characteristics that include collimated beams and, in many cases, a combination of such other factors as remoteness, operation that precludes primary-beam exposure, and motion of the primary beam.

These factors result in estimated time-averaged power densities for most systems that are below $50 \mu\text{W}/\text{cm}^2$ at distances greater than 0.5 mile from the source. Higher power densities may occur closer to the source, especially if exposure to the primary beam is possible.

CHAPTER 2

BIOLOGIC EFFECTS RELATED TO EXPOSURE TO RADIOFREQUENCY WAVES

The introduction of new physical and chemical factors into the environment or an increase in the presence of existing ones dictates an analysis of potentially adverse biologic and ecologic effects, especially potential effects on the health of exposed human populations. The purpose of this chapter is to review information pertinent to the assessment of the potential effects of human exposure to electromagnetic radiation in the radiofrequency range, particularly microwave radiation and to the extent possible radiation similar to that of the PAVE PAWS radar.

It must be noted that the present state of knowledge of the effects of radiofrequency exposure on living systems, such as the exposure that may be anticipated from PAVE PAWS, is not adequate to define clearly the risks involved, although some general conclusions may be drawn relative to specific biologic end points. It should be emphasized that such limitations on the determination of risks of human exposure to microwave or to other radiofrequency (RF) radiation are not limited to the PAVE PAWS radar, but pertain in general to all sources of such exposure.

The inherent uncertainties in the evaluation of the biologic effects of microwave and other RF radiation are due in part to the absence of an adequate data base, especially with respect to the effects of chronic or long-term exposure to low radiation intensities. The application of available data, most of which have been derived from studies of acute exposure of other species, to the assessment of human effects is difficult because of, among other things, the manner in which such radiation is absorbed, which results in complex, wavelength-dependent, nonuniform energy distribution in the bodies of experimental animals. Recent investigations have revealed that microwave and other RF absorption patterns depend on the frequency or wavelength of the radiation and the size, shape, and orientation of the body with respect to the radiation field. It is therefore difficult to apply results of experimental-animal studies at a given radiation frequency to other species, such as man, exposed at the same or a different frequency. Although the consequences of nonuniform microwave-energy absorption in mammalian systems are not well understood, it is likely that such effects are involved in some types of alterations to be described in this chapter.

The effects of microwave radiation on living systems may be arbitrarily categorized as effects of high field intensities or low field intensities. High-field-intensity effects may be defined as effects associated with a degree of absorption of microwave energy that results in readily detectable increases in whole-body average temperature. Exposures of laboratory animals to such field intensities have been shown to result in a variety of physiologic alterations; prolonged exposure to

such fields will lead to irreversible changes, such as cataract induction, and death as a result of excessive thermal stress. Low-intensity-field effects may be defined as effects that are not associated with detectable increases in whole-body average temperature. On the basis of most of the available data, the known or suspected low-intensity-field effects are reversible: conditions revert to normal soon after exposure is terminated. As previously noted, microwave-energy absorption depends on the physical and geometric characteristics of the absorber, as well as on the presence of reflecting surfaces in the surroundings. Consequently, it is not generally possible to specify a priori whether a given microwave frequency and intensity will result in a low- or a high-intensity-field effect in a given mammalian species. However, on the basis of data derived from both theoretical calculations and experiments with various species exposed to microwave radiation, a field intensity of around 1.0 mW/cm^2 will be used in this report to demarcate low- and high-intensity fields.*

In the frequency range of 10-10,000 MHz, exposure to field intensities of 1 mW/cm^2 will result in maximal energy absorption of approximately 1 mW/g , which is equivalent to the quantity of heat generated by normal human metabolism when averaged over the total body mass in the sleeping state. Absorption of microwave intensities of around 1 mW/g will thus add a thermal load equivalent to the whole-body average basal metabolic rate. Such absorption may result in temperature increases in specific tissues equivalent to those resulting from normal light physical activity. In view of such factors as the previously noted nonuniformity of body heating induced by microwave absorption, it is not possible to evaluate potential biologic effects of microwave radiation solely on the basis of comparisons with the heat generated by basal metabolic processes. However, if a time-averaged exposure intensity of 1 mW/cm^2 is used to differentiate high- from low-field intensity effects, the class of effects to be anticipated from exposure to PAVE PAWS radiation may be specified. The available theoretical and experimental data relative to the field intensities anticipated in areas of public access in the vicinity of PAVE PAWS suggest that effects in humans will be restricted to the class of low-intensity effects, inasmuch as exposures apparently will be at intensities less than 1 mW/cm^2 .

To provide the necessary perspective for assessing the potential exposure effects of PAVE PAWS radiation, the Panel has reviewed the known biologic effects of microwave radiation, with particular attention to low-field-intensity effects. The available data are not extensive enough to permit specific conclusions to be drawn, but some general conclusions may be arrived at on the assumption that effects will be limited to low-field-intensity microwave effects. In contrast with the effects of exposure to low doses of ionizing radiation, exposure to low-intensity microwave or RF radiation has not been reported to result in detectable increases in the incidence of irreversible somatic or genetic effects, such as cancer or genetic mutation. This statement is consistent with the

*"Field intensities" in this report refers to time-averaged intensities, unless otherwise indicated.

known mechanisms of interaction of low-intensity microwave or RF radiation with biomolecules, which consist primarily of induced molecular rotations that are not known to be associated with irreversible molecular structural or conformational alterations. The genetic and somatic effects of ionizing radiation, however, are known to be a consequence of the substantially greater energy quanta of this type of radiation, which endow it with the ability to ionize or disrupt bonds in biomolecules and so lead to irreversible molecular structural alterations that are manifested in irreparable damage to the organism.

In general, therefore, the documented low-field-intensity microwave effects are not associated with irreversible alterations or increased morbidity or mortality. Such effects as do occur appear to be reversible and have been more prominently associated, by some investigators, with psychologic alterations in mood or attitude; this has led to the suggestion that it is principally the central nervous system that is sensitive to low-intensity microwave exposure. At present, except as noted below, there is no well-defined theoretical basis for the sensitivity of the central nervous system to microwave radiation, but experimental data suggest that neuronal membranes may be involved.

Reversible alterations in neural systems, which have been reported to occur at field intensities that do not result in significant whole-body heating, appear to be related to the pulse modulation rate, as well as to the instantaneous or peak field intensity. Although specific effects, such as the audible perception of pulse-modulated microwave fields (the so called "microwave hearing" phenomenon), have been tentatively attributed to very rapid but slight heating of structures in the head, most of the reported central-nervous-system effects have not been adequately characterized or theoretically explained. In the absence of knowledge of the basic mechanisms of such effects and of verified data on their incidence in humans, it is not possible to predict the exposure conditions under which such effects will occur, nor is it possible to assess their consequences if they are, in fact, induced by exposure to low-intensity microwave fields. Again, in contrast with human exposures to ionizing radiation, where dose-response relationships for well-defined and quantifiable end points may be specified and relative or absolute risk determined, low-field-intensity microwave effects, because of their characteristics and the present lack of data, cannot be evaluated by such means.

In view of the present limitations on the ability to assess the risks involved in human exposure to low-intensity microwave radiation, the approach used here in considering the potential exposure effects related to PAVE PAWS is to characterize, to the greatest extent possible, the anticipated exposures and to contrast these exposures with those encountered in other situations where humans are exposed to microwave or other RF radiation. In characterizing exposures to PAVE PAWS radar, all the factors that are shown to affect incident microwave exposure intensities and absorption in humans must be taken into account to provide an indication of the most probable degrees of exposure, as well as the maximal exposures (or "probable worst-case" situations) that could theoretically be encountered.

Although, as indicated above, it is not possible to translate the anticipated exposures into determinations of risks to humans, a review of pertinent biologic effects is presented here to provide some perspective for the future consideration of the risks and benefits of the radiation exposure to be encountered as a result of the operation of the PAVE PAWS radar system.

PHYSICAL FACTORS AFFECTING MEASUREMENT OF ABSORBED RADIOFREQUENCY
DOSE IN BIOLOGIC SYSTEMS

STATE OF KNOWLEDGE OF ELECTROMAGNETIC ABSORBED DOSE IN MAN AND ANIMALS

The dose of microwave or radiofrequency radiation absorbed by biologic material depends on such physical factors as the size and shape of the irradiated object and the wavelength and frequency of the radiation. These physical factors are discussed here in the context of human exposure to radiation of the PAVE PAWS type, and then the information is applied to estimation of the dose that humans might absorb as a result of exposure to PAVE PAWS frequencies.

Free-Space Irradiation

The experimental condition that has been used in most studies is free-space irradiation of single animals. The whole-body absorption of electromagnetic waves by biologic bodies depends strongly on the orientation of the electric field relative to the longest dimension (L) of the body. The highest rate⁵² of energy deposition occurs in fields that are polarized parallel to the longest dimension of the body ($\vec{E} \parallel \hat{L}$) and at such frequencies that the longest dimension is approximately 0.36-0.4 times the free-space wavelength (λ) of radiation. Peaks of whole-body absorption for the other two configurations--longest dimension oriented along the direction of propagation ($\vec{K} \parallel \hat{L}$) or along the vector of the magnetic field ($\vec{H} \parallel \hat{L}$)--have also been reported⁵³ for approximately twice the weighted average circumference of the animals.

On the basis of prolate spheroidal and ellipsoidal equivalents of biologic bodies, theoretical calculations have recently been given in a dosimetry handbook⁸² for frequencies up to and slightly beyond the resonant region for the aforementioned orientations-- $\vec{E} \parallel \hat{L}$, $\vec{K} \parallel \hat{L}$, and $\vec{H} \parallel \hat{L}$. Numerical calculations with a realistic model⁷³ of man have shown a more pronounced frequency dependence in the whole-body absorption at frequencies higher than the whole-body resonant frequency. Minor peaks in the supreresonant region are ascribed to maximums of energy deposition in the various body parts, such as the arm and the head.⁵⁵

For the supreresonant region, the $\vec{E} \parallel \hat{L}$ orientation has been studied most extensively. In this region, whole-body absorbed dose is experimentally observed⁵⁷ to be inversely proportional to frequency (F) for frequencies up to 1.6_{res} times the resonant frequency f_r , where S_{res} is

the relative absorption cross section (defined as absorption cross section divided by physical cross section) at the resonant frequency.

Empirical equations have been derived⁵⁷ for the mass-normalized rate of electromagnetic energy deposition (specific absorption rate, SAR) for $\vec{E} \parallel \hat{L}$ orientation. These equations are as follows:

Peak absorption or resonant frequency:

$$f_r = (11,400/L_{cm}) \text{ MHz.} \quad (9)$$

For subresonant region -- $0.5 f_r < f < f_r$:

$$\text{SAR in mW/g for 1 mW/cm}^2 \text{ incident plane waves} = 0.52 \frac{L_{cm}^2}{\text{mass in g}} \left(\frac{f}{f_r} \right)^{2.75} \quad (10)$$

For supraresonant frequency region -- $f_r < f < 1.6 S_{res} f_r$:

$$\text{SAR in mW/g for 1 mW/cm}^2 \text{ incident plane-wave fields} = \frac{5950}{f_{\text{MHz}}} \frac{L_{cm}}{\text{mass in g}}, \quad (11)$$

where L_{cm} is the long dimension of the body in centimeters and

$$S_{res} = 0.48 \left(\frac{L_{cm}^3}{\text{mass in g}} \right)^{1/2}. \quad (12)$$

Because human subjects cannot be used for experimentation, the empirical equations have been checked by experiments with six animal species from 25-g mice to 2,250-g rabbits and found to be fairly accurate. For reasons not as yet understood, the measured SAR values for experimental animals are approximately 59% higher than those given by Equations 10 and 11, which were derived from experiments with figurines.

For free-space $\vec{E} \parallel \hat{L}$ irradiation, SARs considerably higher than the whole-body average are obtained for the neck, the legs, and the elbows (Gandhi et al.⁵⁸ and Gandhi and E. L. Hunt, unpublished data), with the lower torso receiving SARs comparable with the average and the upper torso receiving SARs lower than the average. The deposition rates at the locations of maximal absorption, or hot spots, may be 5-10 times the whole-body-averaged SARs given by Equations 10 and 11.

Electromagnetic Absorption in Humans and Animals in the Presence of Nearby Ground and Reflecting Surfaces

Only highly conducting (e.g., metallic sheet) ground and reflecting surfaces^{57,73} of infinite extent have been studied in attempts to determine absorption of electromagnetic waves in the presence of reflecting surfaces. For a standing-man model with feet in conductive contact with a perfect ground, there is a drastic alteration in SAR as a function of frequency. For $\vec{E} \parallel \hat{L}$

orientation, the new resonant frequency is roughly half that given by Equation 9. At this lower resonant frequency, the SAR is about twice that at the peak absorption frequency for free-space irradiation.

For feet in conductive contact with the ground, the highest SARs are observed for the ankles and legs. The deposition rates at the hot spots, again, are 5-10 times larger than the whole-body averaged SAR under these conditions.

The nature of the ground effects on SAR (for $\vec{E} \parallel \hat{L}$ orientation) is such that even a small separation,^{54,56,73} from ground (breaking the conductive contact) is sufficient to eliminate much of the ground effect. For separations from ground of more than about 3-4 in. (7.6-10.2 cm), the total energy deposition and its distribution are identical with those for free-space irradiation conditions. Even for a human model in conductive contact with a perfect ground,³ the energy deposition in the suprarsonant region ($f > 2-3 f_r$) is comparable³ with that for free-space irradiation.

Other orientations and finite-conductivity ground effects on SAR have not been studied.

For highly conducting (metallic sheet) reflecting surfaces of flat and 90°-corner types, increases⁵⁷ in SAR by factors as large as 27 have been observed for the $\vec{E} \parallel \hat{L}$ orientation. Most of the work done so far has concentrated on frequencies close to the resonant region. The observed increases are explained⁵⁷ on the basis of antenna theory.⁸¹ Indeed, for incident-plane waves for $\vec{E} \parallel \hat{L}$ orientation, most of the observed results imply that the irradiated target acted like a pickup half-wave dipole with reflecting surfaces close by.

Finite-conductivity, finite-size reflecting surfaces and other orientations have not been considered. Results for frequencies higher than about 8.5 times the resonant frequency (550 MHz for man) have not been obtained, even for highly conducting reflectors.

Enclosed structures, such as rooms, may act as lossy resonators with electromagnetic fields being coupled from the windows. If such structures have highly reflecting walls, field enhancements by one or two orders of magnitude may indeed be possible. However, because walls typically encountered are not very reflecting, power-density increase¹⁴⁰ by a factor of more than about 5-10 may not be realistic. Further research into the reflection characteristics of these structures is needed in order to describe precisely the nature of field enhancement.

Head Resonance

Gandhi et al. have recently identified a frequency region for the highest rate of energy deposition in the head. The head resonance^{55,56,72} occurs at such frequencies that the head diameter is approximately one-fourth of the free-space wavelength. For the intact (adult) human head, the resonant frequency is estimated to be around 350-400 MHz. At head resonance, the absorption cross section for the head region is approximately 3.0 times the physical cross section with a volume-average SAR that is about 3.3 times the SAR averaged^{83,158} over the whole body. Both values greatly exceed numbers reports earlier^{83,158} for spherical models of the isolated

human head. Numerical calculations⁷² based on 144 cubical cells of various sizes to fit the shape of the human head (340 cells for the total body) yielded local SARs at hot spots (above the palate area and the upper part of the back of the neck) about 5 times the average values for the head.

Multianimal Effects⁵⁵

For resonant biologic bodies close to one another, antenna theory may be used to predict the modification in SAR relative to free-space values. For two resonant targets separated by 0.65 to 0.7λ , the highest SAR (150% of the free-space value) can result for man and animals in an $\vec{E} \parallel \hat{L}$ orientation for frontally (broadside) incident plane waves. For three animals in a row with an interanimal spacing of 0.65λ , the central-animal SAR would be roughly 2 times that for an isolated animal, and the end-animal SARs would be approximately 1.5 times that for an isolated animal.

Full implications of the multibody effects on SAR are not completely understood, even though pilot experimental studies⁵⁵ with anesthetized rats showed that the above-mentioned increases may also occur for sub-resonance and suprarsonance regions. Other orientations, irregular spacings, and non-free-space exposure conditions have not been considered.

Multilayer Effects

Most of the results outlined above were obtained for homogeneous models of man with tissue properties averaged on the basis of 65% muscle, skin, and tissues with high water content and 35% fat, bone, and tissues with low water content. Some of these results were checked by experimentation with small laboratory animals. Gandhi's group (P. W. Barber, O. D. Gandhi, M. J. Hagmann, and I. Chatterjee) has recently studied the effects of tissue layering on energy deposition in a multilayer model of the whole body of man. Their calculations showed that layering in humans can alter the results somewhat for frequencies above 500 MHz, but the homogeneous model was found to be quite appropriate at frequencies lower than 500 MHz.

Calculations for the Electromagnetic Absorption in Humans for PAVE PAWS Frequencies

The Panel used the dosimetric information summarized above to estimate the electromagnetic absorption in man for PAVE PAWS frequencies. These calculations were based on the following assumptions: a 70-kg, 1.75-m average-sized man; a 32.2 kg, 1.38-m, 10-yr-old child; and a 3.5-kg, 0.4-m average-sized infant. The average head diameters for the man, child, and infant were taken to be 21, 12, and 8.7 cm, respectively. A free-space incident power density of 0.1 mW/cm^2 was assumed in calculating the mass-normalized rates of electromagnetic energy disposition (SAR) given in this section. Table 13 shows calculated SARs for the $\vec{E} \parallel \hat{L}$ orientation for the whole body and the head and estimates of expected deposition rates for local areas of the body and head. Resonant frequencies for the body and head are also described. Table 13A describes SARs for free-space exposure conditions, and Table 13B for non-free-space conditions. Table 14 summarizes the results of calculations of the "probable worst-case" SARs predictable under conditions of exposure to PAVE PAWS radiation in buildings with unscreened windows facing the antenna, where field power density may be increased.

TABLE 13

Mass-Normalized Rates of Energy Deposition
(Assumed Incident Power Density, 0.1 mW/cm²)

A. Free-space irradiation; $\vec{E} \parallel \hat{L}$ Orientation

<u>70-kg, 1.75-m adult</u> <u>man</u>	<u>32.2-kg, 1.38-m 10-yr-old</u> <u>child</u>	<u>3.5-kg, 0.4-m</u> <u>infant</u>
--	--	---------------------------------------

From Equation 9, whole-body resonant or peak absorption frequency (f_r) in MHz = 11,400/ L_{cm} , where L_{cm} is length in centimeters.

$f_r = 65.2$ MHz	$f_r = 82.6$ MHz	$f_r = 285$ MHz
------------------	------------------	-----------------

From Equation 11, the whole-body averaged SAR =

0.0035 mW/g at 420 MHz	0.0061 mW/g at 420 MHz	0.016 mW/g at 420 MHz
0.0033 mW/g at 450 MHz	0.0057 mW/g at 450 MHz	0.015 mW/g at 450 MHz

Deposition rates 5-10 times higher than whole-body average SARs are expected for the neck, the legs, and the elbows for these irradiation conditions.

Head resonance frequency ($f_{h,r}$) $\approx 7,500/d_h$, where d_h is average head diameter in centimeters

$f_{h,r} \approx 357$ MHz	$f_{h,r} \approx 625$ MHz	$f_{h,r} \approx 862$ MHz
Head-averaged SAR: ⁷²	Head-averaged SAR: ⁵⁵	Head-averaged SAR: ⁵⁵
0.019 mW/g at 420 MHz	0.014 mW/g at 420 MHz	0.0075 mW/g at 420 MHz
0.016 mW/g at 450 MHz	0.011 mW/g at 450 MHz	0.014 mW/g at 450 MHz

Deposition rates about 5 times higher than head-averaged SARs may occur at hot spots above the palate area and the upper part of the neck.

TABLE 13
(Continued)

B. Non-free-space irradiation

$\vec{E} \parallel \hat{L}$ Orientation

The above values should also be applicable for conditions of electric contact with high-conductivity ground.

SARs increased by factors of 5-20⁵⁷ may be encountered in the presence of highly conducting (metallic sheet) reflecting surfaces of flat and 90°-corner types. Smaller increases are expected for imperfectly reflecting surfaces.

Even though enclosed structures, such as rooms, have not been studied at length, field increases by factors of some 5-10 have been reported,¹⁴⁰ presumably owing to reflections from walls, of electromagnetic energy coupled in from windows.

Increase in SAR by a factor of no more than 2 may occur, owing to proximity to other human beings.

Other Orientations

The SAR values for other orientations are likely to be no more than those for $\vec{E} \parallel \hat{L}$ orientation given above.

TABLE 14

Rates of Energy Deposition for "Probable Worst-Case"^a Exposure Conditions
(Assumed Incident Power Density, 0.1 mW/cm²)

<u>70-kg, 1.75-m adult</u> <u>man</u>	<u>32.2-kg, 1.38-m 10-yr-old</u> <u>child</u>	<u>3.5-kg, 0.4 m</u> <u>infant</u>
Whole-body-averaged SAR 435 MHz, corresponding to average PAVE PAWS frequency:		
$7.5 \times 0.0034 =$ 0.026 mW/g	$7.5 \times 0.0059 = 0.044 \text{ mW/g}$	$7.5 \times 0.0155 =$ 0.12 mW/g
$\approx 0.26 \text{ mW/g}$	SAR at hot spots: $\approx 0.44 \text{ mW/g}$	$\approx 1.16 \text{ mW/g}$
$\approx 7.5 \times 0.0175 =$ 0.13 mW/g	Head-averaged SAR: $\approx 7.5 \times 0.012 = 0.09 \text{ mW/g}$	$\approx 7.5 \times 0.0108 =$ 0.08 mW/g
$\approx 0.66 \text{ mW/g}$	SAR at hot spots in the head: $\approx 0.47 \text{ mW/g}$	$\approx 0.4 \text{ mW/g}$

^aField increase by factor of 7.5 assumed in these calculations. Such a factor is likely to be among highest that may be encountered in buildings.¹⁴⁰ Field increases of this type would be fairly localized. Furthermore, metallic screen at windows facing antenna installation would keep most fields out.

The SARs calculated in Table 14, for the "probable worst case" (maximal SAR at a "hot spot" in the head of 0.66 mW/g) for an adult human being, may be compared with the typical metabolic rates for an adult human being^{1,147}

Whole-body averages

Basal metabolic rate	1.08 mW/g
Light-activity metabolic rate	1.66 mW/g
Metabolic rate for slow walking	3.32 mW/g

Local values

Brain metabolic rate	11 mW/g
Heart-muscle metabolic rate	33 mW/g

LOCALIZED POWER ABSORPTION DUE TO ATTACHED INSTRUMENTATION AND IMPLANTS

When conducting objects, wires, or electrodes (such as surgical pins or pacemakers) are brought into contact with or implanted in biologic tissues exposed to electromagnetic fields, high-intensity fields may be induced locally where the conductors contact tissue. These fields can be much greater than the fields that would normally be present without the conductors. Although it is beyond the scope of this discussion to analyze quantitatively the fields induced in tissue owing to various implants under all exposure conditions, some examples based on simplistic analyses can be discussed.

Guy et al.⁶⁹ have demonstrated some possible situations by using simple first-order analytic determinations of the field increase that occurs in tissues as a result of the presence of conductors. These simple examples illustrate the increase due to wires that connect external instrumentation to electrodes in contact with the tissues, implanted encapsulated instrumentation (such as pacemakers), and implanted conductors (such as surgical pins and prosthetic joints).

In all these cases, currents are induced in the conductor portions of the instrumentation or implants and result in field increase and in an increased SAR (W_e), which is much greater than the normal SAR (W). The value of W_e will in general increase with the length of the leads or the implant. The factor of SAR increase due to an external conductor of length L and radius a in contact with an exposed subject was found to be:

$$\frac{W_e}{W} = \left[\frac{\pi \epsilon_0 | \epsilon_m^* | f}{\sigma_m \ln \left(\frac{2L}{a\sqrt{3}} \right)} \right]^2 \left(\frac{L}{\pi} \right)^4, \quad (13)$$

when L is assumed to be smaller than the wavelength, ϵ_0 is the permittivity of free space, ϵ_m^* is the complex dielectric constant of the tissue, σ_m is the electric conductivity of the tissue, and f is the frequency. When the length of the wire is appreciable, compared with the wavelength, the intensification factor would be even greater than that for short leads. For muscle tissue and an exposure frequency of 450 MHz, $|\epsilon_m^*|$ is equal to 78, and the electric conductivity of σ_m is 1.43 S/m. Inserting these values in Equation 13, we obtain

$$\frac{W_e}{W} = 1.36 \left[\ln \left(\frac{2L}{a\sqrt{3}} \right) \right]^{-2} \left(\frac{L}{a} \right)^4 \quad (14)$$

With $L/a = 10$, $W_e/W = 1.67 \times 10^3$; with $L/a = 100$, $W_e/W = 4.43 \times 10^6$. Thus, the presence of the wire results in large SAR intensification at the point of contact. The SAR increase due to metallic implants in tissues may be illustrated by considering the conducting prolate spheroid with major axis L and minor axis $2a$ imbedded in tissue in the presence of an electric field. The enhancement factor discussed by Guy⁶⁶ is:

$$\frac{W_e}{W} = [u_0^2 - 1] (u_0 \coth^{-1} u_0 - 1)^{-2}, \quad (15)$$

where

$$u_0 = \cosh \left[\tanh^{-1} \frac{2a}{L} \right]. \quad (16)$$

For a spherical implant where $L/2a$ approaches unity, the factor is 9. When the ratio is 5, the factor is 321; when the ratio is 10, the factor is 2.43×10^3 ; and when the ratio is 100, the factor is 5.4×10^6 . With increasing ellipticity, the SAR increases substantially, but the volume of tissue affected is small, because the intensification region extends to a distance of about the radius of the conductor.

For an implanted insulated wire, with conductor radius a , insulation radius b , insulation dielectric constant ϵ_d , and the end of the conductor in direct contact with the tissue, the enhancement factor may be expressed as

$$\frac{W_e}{W} = \left[\frac{\pi f \epsilon_0 \epsilon_d}{\sigma_m \ln(b/a)} \right]^2 \left(\frac{L}{a} \right)^4. \quad (17)$$

For a frequency of 450 MHz with $\epsilon_d = 2.25$ and $b/a = 2$, the enhancement factor given above may be expressed in terms of the ratio of wire length of radius:

$$\frac{W_e}{W} = 3.23 \times 10^{-3} \left(\frac{L}{a} \right)^4. \quad (18)$$

When $L/a = 5$, the factor is 2; when $L/a = 10$, the factor is 3.2; and when $L/a = 100$, the factor is 3.23×10^3 . This indicates that substantial field increases can occur even for the implanted insulated conductors. However, such increases probably result in highly localized transient heating in the immediate vicinity of conductive implants in tissue exposed to microwave fields with time-averaged intensities greater than $1 \mu\text{W}/\text{cm}^2$.

CARDIAC-PACEMAKER INTERFERENCE

Mitchell ¹¹² reported an extensive study on the interference of cardiac pacemakers from radar-like pulses, including those operating at frequencies of 450 MHz. The study indicated that field intensities of radar-like pulses above some threshold can disrupt normal pacemaker function and create a potential hazard for the user; that the pacemakers tested were most susceptible to interference at frequencies of 500-1,000 MHz, with the interference threshold inversely proportional to pulse width; that fields with a pulse-recurrence rate of 1-10 pulses/s and a peak above the pacemaker's interference threshold would stop the operation of a pacemaker; and that when the effective pulse-recurrence rate was greater than some inherent value (which depended on the particular device), the pacemaker would revert to an interference-rejection mode by operating at a fixed rate. It was noted in the report that operation of a pacemaker at a fixed rate is generally judged nonhazardous, whereas inhibition of the output of the device is judged hazardous.

Pacemakers were tested with the Association for the Advancement of Medical Instrumentation technique of simulating implantation by placing the pacemaker in an 80-cm x 40-cm x 20-cm container made of 5-cm-thick plastic foam and filled with 0.03 M saline solution. The pacemaker and leads are placed so that there is 1 cm of solution between the pacemaker and the wall of the container. The implanted pacemaker was exposed under controlled laboratory conditions to circularly polarized 450-MHz fields with electric-field strengths up to 292 V/m. The pulse widths and pulse-repetition rates were varied between 1 μs and 1 ms and between 2 and 40 pulses/s, respectively. Table 15 summarizes the results of Mitchell's report pertaining to 450 MHz inference.

An adverse effect is defined when the pacemaker rate falls below 50 beats/min (bpm) or exceeds 125 bpm as a direct result of electromagnetic interference. The data in the table illustrate the wide range of susceptibility to electromagnetic interference from 8 V/m to over 300 V/m of the 23 pacemaker models tested. Results show a dramatic improvement of new models, such as the American Optical 281143 over the older models AO 281003 and 281013 and the Starr Edwards new model 8116 over the older model 8114. The report indicated that, with design improvements in the newer models, the interference problem should be eliminated. However, older, maximally susceptible pacemakers may be affected by exposure to PAVE PAWS radiation fields, especially near the exclusion area, where instantaneous field strengths in excess of 10 V/m may be encountered. The scanning mode of the radar beam would, however, be expected to induce only transient pacemaker interference, rather than a complete cessation of operation or a continual increase in rate exceeding 125 bpm.

TABLE 15

Summary of Adverse-Effect Thresholds for Cardiac-Pacemaker Electromagnetic Interference
(Simulated-Implant Condition Frequency, 450 MHz; Pulse Width, 1 ms)^a

Pacemaker Manufacturer and Model Number	V/m (bpm)			
	Pulse Repetition Rate in pps:			
	2	10	20	40
American Optical 281003	13(0)	--	15(0)	243 (0)
American Optical 281013	26(0)	--	26(0)	--
American Optical 281143	>300	--	--	>300
Biotronik IDP44	141(0)	>300	>300	>300
Cordis Atricor 133C7	>300	>300	--	141(172)
Cordis Omni-Atricor 164A	>300	>300	--	>300
Cordis Stanicor 143E7	15(0)	15 (0)	243(0)	>300
Cordis Omni Stanicor 162C	8(0)	9 (0)	--	>300
General Electric A2072D	29(0)	207(125)	--	--
General Electric A2075A	23(0)	141(125)	--	--
Medcor 3-80A	29(0)	141 (0)	141(0)	141 (0)
Medtronic 5842	15(0)	--	15(0)	15 (0)
Medtronic 5942	12(0)	--	12(0)	12 (0)
Medtronic 5943	23(0)	--	19(0)	>300
Medtronic 5944	26(0)	26 (0)	>300	>300
Medtronic 5950	>300	--	--	>300
Medtronic 5951	>300	--	--	>300
Medtronic 9000	10(0)	10 (0)	10(0)	>300
Pacesetter BD-101	>300	--	--	>300
Starr Edwards 8114	23(0)	--	>300	--
Starr Edwards 8116	>300	>300	--	>300
Stimtech 3821	107(0)	114 (0)	>300	--
Vitatron MIP-40-RT	93(0)	107 (0)	243(0)	243 (0)

^aData from Mitchell.¹¹² Adverse-effect threshold is assigned when pacemaker rate falls between 50 beats per minute (bpm) or exceeds 125 bpm as a direct result of electromagnetic interference.

BIOLOGIC EFFECTS

EFFECTS ON CENTRAL NERVOUS SYSTEM AND OTHER NERVOUS TISSUE

Stimuli to the nervous system may be evaluated on the basis of their behavioral effects or the concurrent physiologic or biochemical changes induced in the brain or other nervous tissue. In some instances, there may be alterations in tissue ultrastructure, discernible microscopically.

Effects of low-level, nonionizing electromagnetic fields on nervous tissue are related in part to RF carrier-wave frequencies and to patterns of amplitude modulation. Brain tissue may be sensitive to imposed fields only within narrow ranges of incident energy.

Electroencephalographic Alterations

Both acute and chronic exposures to microwave fields have been reported to change EEG patterns in humans and animals. According to Barański and Edelwejn,¹³ technicians repeatedly exposed to presumed high-level fields in radar-repair shops may eventually exhibit flat EEG records associated with subjective complaints of headaches and copious sweating, but no precise data on field characteristics are available.

In animal studies, Barański and Edelwejn¹³ noted high-amplitude "desynchronized" records in rabbits after 3-4 months of exposure for 2 hr a day to fields of 2,950 MHz, average power of fields with 5.0 mW/cm² and 1.0- μ s pulses at 1,200 pulses/s under far-field conditions in an anechoic chamber.

Major changes in rabbit EEG patterns have also been reported by U.S. investigators after 4-6 weeks of exposure to radiofrequency fields at much lower frequencies (3-5 MHz) with 14-Hz modulation.^{14,5} Two opposing effects were noted. With fields at 90-150 V/m, there was increased activity at higher EEG frequencies (10-15 Hz). Fields at 500 V/m increased the effects of lower frequencies (4-5 Hz), and the increased low-frequency activity was associated with suppression of high-frequency activity. It is unlikely that these effects are attributable to thermal changes in brain tissue. Facilitation of microwave-induced desynchronization by small amounts of pentobarbital has also been reported.^{14,61}

Brain sensitivities have been studied at a carrier frequency of 450 MHz, with sinusoidal amplitude-modulation frequencies of 5-30 Hz, which are modulation components used in long-range radar systems. Findings in laboratory studies with similar RF and modulation characteristics may disclose bioeffects likely to occur near long-range radar transmitters with appropriately scaled field intensities.

Sensitivity of the EEG modulation frequencies on a low-level (0.8-mW/cm²) VHF (147-MHz) carrier was demonstrated by Bawin et al.¹⁸ in cats; imposition of this field increases occurrence of a brief burst of

EEG waves in particular brain structures, when the modulation and EEG wave-burst frequencies are similar. This EEG burst can be trained as a conditioned behavioral response to an environmental light or sound stimulus. The rate of correct responding is then substantially increased, and extinction of the response is delayed for many days in the presence of the RF field. After 20 min of exposure to 450-MHz fields, with a 1.0-mW/cm² amplitude modulated at 16 Hz, neonate chicks have sharply higher EEG power spectral density at frequencies from 14 to 25 Hz for 2 h or more.¹⁶ Chronic exposure of rats to 3.0-GHz, 5.0-mW/cm² fields with 500 pulses/s is followed by a persistent 500-Hz component in the EEG spectrum.¹³⁴

These studies support the concept that microwave fields modulated at EEG frequencies may actually entrain neuroelectric activity of brain structures that generate intrinsic electric rhythms at the same or closely related frequencies. Microwave fields modulated at much higher frequencies, typically at radar pulse-repetition frequency (PRF) rates between 300 and 1,500 pulses/s, may also modify EEG activity and produce effects not seen with continuous-wave (CW) fields of the same average power.¹³ Fields pulsed in the audible range (2850 MHz; 2.7 μs; repetition frequency, 357 Hz; average power density, 30 mW/cm²) diminished sensitivity to audiogenic seizures in rats exposed for 4 h a day for the first 10 weeks of life.¹⁴²

A distinction should be drawn between microwave fields that appear to influence brain-tissue excitability directly and fields that are sufficiently intense to induce thermal stress. The latter may be associated with endocrine changes,¹⁰⁹ and EEG patterns may then shift as an element in the stress response. This distinction is clearly justified for frequency-specific low-frequency modulations cited above. Those fields raise the isolated brain temperature by less than 0.1°C, and brain-tissue dosimetry shows gradients of 100 mV/cm for incident 450-MHz fields of 1.0 mW/cm².²⁰ Indeed, EEG entrainment has been reported for 7-Hz extremely low-frequency (ELF) fields, which produce far weaker tissue gradients of around 10⁻⁷ V/cm.⁵⁹ Comparison and neuronal firing thresholds of single invertebrate ganglion cells (*Aplysia californica*) in microwave fields and during warming indicate that both alter firing rates with shifts around 0.1°C, although qualitatively different responses may occur in the same cell with comparable small temperature increments induced by the two stimuli.^{132,157}

Absorbed radiation doses in brain tissue of small mammals may be modified in a complex way by resonances attributable to whole-body geometry as a function of the wavelength of the incident field. The cranial cavity itself may be resonant, with sharply higher absorption of 2,450 MHz for the monkey.⁹⁰ For the larger head of man, this resonance occurs between 350 and 400 MHz, and for a child, between 600 and 850 MHz⁵⁶--a factor to be considered in establishing safety guidelines near radar transmitters operating in this frequency range.

Microwave Effects on Blood-Brain Barrier

The passage of ions and molecules from cerebral blood vessels to the environment of brain cells is normally restricted or prevented by barriers associated with the blood vessels themselves. A continuous layer of endothelial cells line cerebral capillaries. Electron microscopy shows so-called "tight junctions" joining these cells, which appear to lack pinocytotic vesicles that provide a mechanism for trans-membrane transport of molecules into the interior of other cells. Oscar¹¹⁹ has described microwave-induced changes in brain uptake and distribution of blood-carried proteins, electrolytes, and large water-soluble non-electrolyte molecules in rats, Chinese hamsters, and rabbits.

Oscar and Hawkins noted an apparent increase in permeability of the blood-brain barrier arising from both pulsed and CW microwaves at power levels considerably below 10 mW/cm^2 , with evidence of increased effects of pulsed over CW fields at similar average power. Studies by Oscar,¹¹⁹ Albert,³ and Merritt *et al.*^{107,108} have shown increases in blood-brain exchange of horseradish peroxidase, sodium fluorescein, radiolabeled saccharides, and labeled dibasic phosphate in rats, Chinese hamsters, and rabbits. These substances were scattered in random parts of the brains and showed no consistent pattern of localization of any functional region, at least for substances with molecular weights of 40,000 or less. Fields in these studies ranged from 918 to 2,480 MHz at incident energies of $0.5\text{-}10 \text{ mW/cm}^2$. A thermal basis of these effects has not been clearly established.³

Oscar¹¹⁹ pointed out that these alterations in the blood-brain barrier may be reversible. This may indicate changes in tight-junction integrity or pinocytotic transport, rather than cell-membrane destruction. The observed changes in barrier permeability may also be related to altered cerebral circulation induced by neural stimulation.¹²⁷ It is known that the barrier may be reversibly opened by convulsive episodes, concussion, hypercapnia, acute hypertension, and ionizing radiation.

Effects of Neurotransmitters in Nervous Tissue

Brain neurotransmitters now include a much broader range of substances than was suggested by initial experiments with cholinergic and adrenergic agents three decades ago. Known or suspected brain neurotransmitters now include amines (serotonin, dopamine, and norepinephrine), amino acids (gamma-aminobutyric acid, glutamic acid, and taurine), and a variety of peptides believed to exercise neurohormonal influences at neuronal-membrane receptor sites, apart from any direct influence that they may exercise as transmitters released at synaptic junctions--including peptide hormone molecules and fragments of these molecules. Both western and eastern European studies have therefore focused on possible effects of chronic exposure to low-intensity microwaves on responses to neurotropic drugs that have effects on specific classes of transmitter substances.

Barański and Edelwejn¹⁴ tested rabbits previously exposed chronically to 3.0-GHz pulsed microwave fields at a power density of 7 mW/cm² (total irradiation, 200 at 3 h/day). The authors described this exposure as "sub-thermal." The irradiated animals showed a rapid, desynchronized EEG pattern, which may be attributable to chronic activation of the midbrain reticular formation. Chlorpromazine (at 4 mg/kg) produced a regular rhythmic EEG wave pattern that was consistent with the known action of chlorpromazine in reducing midbrain reticular activity by adrenergic blocking. However, the convulsant hydrazine drug pentylenetetrazole, known to act on the thalamic part of the reticular formation and motor cortex, produced greater effects in irradiated animals than in controls. Barański and Edelwejn¹³ compared the effects of 2,950-MHz CW fields and pulsed fields (1,200 Hz with 1- μ s pulses) at 5-7 mW/cm² on phosphorus-32 incorporation into brain lipid and nucleic acid fractions. Turnover indexes were lower for irradiated than control animals, and greater for pulsed than CW fields at the same mean power density and carrier frequency.

Brain concentrations of norepinephrine, dopamine, serotonin, and 5-hydroxyindoleacetic acid were sharply reduced in animals rendered hyperthermic with 1.6-GHz radiation at 80 mW/cm², with focal absorption in the hypothalamus;¹⁰⁷ but the possible susceptibility of brain neurotransmitter release to much weaker microwave fields was not addressed in these studies. Fields of 10 mW/cm² caused marked slowing of serotonin turnover and a decrease in the firing rate of individual serotonin-dependent neurons.¹⁴¹ It has been suggested that, inasmuch as these neurons are known to participate in the regulation of sleep and wakefulness, as well as in body-temperature regulation, these findings may account for the behavioral and functional effects of low-intensity microwaves reported by Soviet and eastern European researchers.⁶⁰ For the rabbit, a dose-dependent decrease in duration of pentobarbital-induced sleep followed exposure to 1.7- and 2.45-GHz microwave radiation at intensities of 5-50 mW/cm²; this suggests thermal stress as a possible, but by no means exclusive, mechanism.³¹

There is little direct evidence of modification of cholinergic transmission in brain tissue by microwave fields.²⁹ But Soviet workers reported that blood concentrations of cholinesterase were sharply reduced in rabbits exposed chronically to 50-MHz, 2.5-GHz, and 10-GHz fields. Pulse rates of the microwave fields were either 20 or 1,000 pulses/s, and field intensities ranged from 0.5 to 10 μ W/cm². Cholinesterase activity dropped by almost half during 50-MHz, 10 μ W/cm² exposures 90-120 days after the beginning of exposure. A reduction of 25% occurred in similar exposures to the microwave fields at 10 μ W/cm². Gordon and colleagues⁶³ corroborated these findings, at least for fields down to 1.0 mW/cm². Gordon pointed out that the biochemical technique measures "nonspecific" serum cholinesterase and that changes in tissue activity of this enzyme after whole-body irradiation result not from a direct action on molecular structures, but from changes in tissue enzyme concentration attributable to disturbances in neurohormonal regulation of metabolic processes.

Western workers have now confirmed important aspects of these findings of Soviet investigators. Lovely et al.¹⁰⁰ found that rats exposed to 500 $\mu\text{W}/\text{cm}^2$, 2,450-MHz CW fields 7 h/day for 3 months showed initial decreases in blood cholinesterase, and then a return to control values. The isolated rat heart was slowed (bradycardia) by 960-MHz CW fields at a specific adsorption rate of 1.5 W/kg (incident energy of approximately 1.5 mW/cm^2). When parasympathetic and sympathetic nerves were simultaneously blocked by atropine and propranolol, respectively, irradiation was without effect. Atropine plus irradiation caused cardiac acceleration (tachycardia), whereas propranolol plus irradiation produced bradycardia.¹²⁸ The authors concluded that effects of these weak fields may indicate a microwave-neuron or microwave-synapse interaction by a mechanism other than generalized heating of tissues.

Alteration in Cation Fluxes or Binding

Excitatory processes in nerve fibers with production of a nerve impulse involves a transient loss of membrane potential. In the resting state, this potential is about 70 mV. The interior of the fiber is negative with respect to its surroundings—a condition accounted for by high internal potassium and low internal sodium concentrations. A sudden massive inward sodium current and a slower, later outward potassium current provide a reasonable model of the fiber action potential. Calcium is essential for the stability of the membrane potential. It is present in high concentration (2.4 mM) in cerebral extracellular fluid. By contrast, general cytoplasmic contents are kept low (0.1 μM) by active transport into organelles or back into the membrane. For nerve fibers, calcium ions have been described as a "plug in the bath" with respect of their ability to limit and regulate movement of monovalent sodium and potassium cations through transmembrane channels.

For nerve cells, in contrast with nerve fibers, actions of calcium ions on membrane functions are known to be vastly more complex. Cerebral neurons have dendritic branches typically spreading far away from the body of the cell. Membranes of dendrites and cell bodies participate in the sensing of immunologic, hormonal, and neurotransmitter stimuli. Dendrites may also sense small electrochemical gradients in their immediate environment. Sensing of these weak cell-surface events and their transductive coupling to the interior of the cell appear to depend on calcium at every stage. As to the structural substrate, available evidence supports a "fluid mosaic" in which proteinaceous particles intrude within a fluid lipid bilayer. These particles have stranded terminals extruded onto the membrane surface, terminating in anionic amino sugars (sialic acids). The membrane surface thus forms a polyanionic sheet with a strong affinity for cations, particularly calcium and hydrogen. Structural continuity of the protein particle from the exterior to the interior of the membrane provides a communication pathway, which may undergo conformational changes associated with the binding or release of calcium ions.⁴¹

Calcium binding in cerebral tissue has been found extremely sensitive to some weak vhf (147-MHz) and microwave (450-MHz) fields. With an incident energy of 0.8 mW/cm^2 , 147-MHz fields with sinusoidal amplitude-modulation frequencies from 0.5 to 35 Hz increase $^{45}\text{Ca}^{2+}$ efflux from freshly isolated chick cerebral hemispheres by about 15% for modulation frequencies of around 16 Hz. Increased effluxes were noted over the band of modulation frequencies from 6 to 20 Hz. Unmodulated carrier waves and modulation frequencies above and below this band were without effect. These findings have been confirmed in all essential aspects by two independent groups.^{19,23} Similar experiments with a 450-MHz, 1.0 mW/cm^2 field, amplitude modulated at 16 Hz, also caused an increase in calcium efflux of more than 10%.²¹

Studies by Bawin *et al.*^{19,21} and Blackman *et al.*²³ cited above have shown that, in addition to a modulation-frequency "window," there is an intensity window within which these modifications in calcium binding occur. Increased calcium efflux was maximal for field intensities around 1.0 mW/cm^2 in the studies at 147 MHz by Blackman *et al.* and at 450 MHz in the studies by Bawin *et al.* Bawin *et al.* defined an effective window between 0.1 and 1.0 mW/cm^2 . This corresponds to an electric-field gradient between 17 and 55 V/m.

Theoretical Models of Microwave Interactions with Tissue

The window character of brain-tissue sensitivity in both frequency and intensity domains strongly suggest that these interactions arise in nonequilibrium processes characterized by resonant interactions of macromolecular fixed-charge sites over long atomic distances.^{1,2,17,117} Theoretical and experimental models of these processes currently under review include the following:

- Thermal-phase transitions with quantum amplification as a resonant phenomenon in electric-charge dipoles on surface proteins at very low frequencies.⁶⁴
- "Pumping" of charge sites on proteins by microwave radiation to produce long-range interactions; oscillations at very low frequencies would occur on the basis of limit-cycle phenomena.^{49,50}
- Limit-cycle interactions in surface proteins.⁸⁸
- Tunneling, which may occur with protein carriers in the length of membrane-surface proteins.^{1,78,117}

BEHAVIORAL AND SENSORY EFFECTS

Very small changes in behavioral characteristics are often the most sensitive indicators of an organism's response to exposure to microwave or radiofrequency electromagnetic radiation. However, these measures,

as reported in the literature, have provided little insight on the question of the possible hazards of such exposure, because the distinction between "effect" and "hazard," although critical, may be derived differently by different observers. For example, eastern European scientists more readily equate "effect" with "hazard" than do western scientists. The difficulty of isolating and measuring a behavioral effect of low-intensity electromagnetic fields separately from behavioral effects of other, concurrent environmental exposures also complicates the process of interpreting data related to behavioral effects.

In the following discussion, confirmed reports of behavioral effects of microwave irradiation are reviewed from the perspective of thresholds (the point at which effects are first measurable).

Perception

Dose-rate thresholds of the albino rat's perception of 60-Hz sinusoidally modulated microwaves at 2,450 MHz in a multipath field, as measured by conditional suppression, were found to range from 0.6 to 1 mW/g during 60-s excitations of the field.⁸⁹ The associated minimal energy dose (0.6 mW/g x 60 s) is less than 36 mJ/g, because detection of the field occurred well before the 1-min periods of excitation were terminated. The estimated energy-flux densities of an incident 2,450-MHz plane wave that would result in an energy-absorption rate of 1 mW/g lie between 2 and 6 mW/cm² and would depend on the animal's absorptive cross-sectional area and its orientation with respect to E and H vectors of the incident field.⁵⁷

Perceptual thresholds for short-duration pulsed microwave fields have not been reported, although early reports^{46,47} revealed that human beings can readily hear a train of pulses at peak flux densities near 100 mW/cm² and averaged densities near 50 μW/cm². The RF-hearing effect is believed to result from thermoelastic expansion; i.e., a microwave pulse that rapidly (rise time in microseconds) deposits less than 10 μJ of energy in the head, which would result in a change in temperature of less than 10⁻⁵ K, can produce an elastic wave that is within the range of acoustic sensitivity of the cochlea.^{27,45,95,160} The associated average flux density for a threshold response to a single pulse,⁸⁷ if averaged over 1 s, would be near 10 μW/cm².

Work Stoppage

When microwave irradiation (900 or 2,450 MHz, CW or sinusoidally modulated at 60 Hz) is administered continuously while a hungry albino rat is working at a lever-pressing task for a reward of food, cessation of work under standard environmental conditions typically occurs at a dose rate of 7-10 mW/g.^{84,98} Corresponding flux densities would be around 10 mW/cm² in a plane-wave 900-MHz field (near the adult rat's resonant frequency) and would approximate 25-50 mW/cm² in a 2,450-MHz field. The energy-dose

threshold of work stoppage lies between 8 and 10 J/g, at least for CW and sinusoidally modulated microwaves. Work-stoppage thresholds pulsed radiation have not been reported.

Aversion

Several studies have been performed on mice and rats;^{26,48,114} although there is excellent agreement that microwave radiation at high flux densities produces easily recognizable behavioral and physiologic signs (e.g., hyperactivity followed by torpor, urination, defecation, spreading of saliva on pelt, and "spread-eagle" posturing), there is reason to doubt that these animals can learn to escape from CW or sinusoidally modulated fields that range from barely perceptible to lethal in intensity. Escape of sorts does occur in pulsed fields,⁴⁸ but the behavior of the albino rat near a threshold of averaged flux density approximating $800 \mu \text{ W/cm}^2$ is not permanent withdrawal, but a shift of preference in which the animal with a choice spends more time away from the field than in it. But frequent reentry by the animal into the field does occur. Experimental animals appear to find the field "slightly noxious," but will reenter it from time to time. Aversive action has been reported²⁶ to depend on the fact that thermal receptors in biologic tissue continue to sense heat even after exposure to radiation ceases.

Convulsion

The grand mal seizure occasioned by radiation-induced hyperthermia may be considered the final behavioral indicant consistent with probable survival of the organism.¹²⁵ For frequencies between 915 and 2,880 MHz, for periods of exposure that extend from 0.5 ms⁶⁷ to 15 min,^{85,125} and for pulsed, sinusoidally modulated and CW fields, both plane-wave and multipath, the energy-dose thresholds of convulsion in the albino rat range from 25 to 28 J/g. The corresponding thresholds of flux density vary by orders of magnitude, inasmuch as the convulsion, at least for periods shorter than 20 min, is the result of a time-intensity product.

As indicated earlier, some of the data from behavioral studies in which fields (average flux density, less than 10 mW/cm^2) have been used do indicate effects that are not necessarily construed as deleterious in the absence of correlative data on irreversible functional or structural impairment. One recently reported study¹⁰⁰ that does exemplify the integrative approach involved intermittent exposure (7 h/day) of rats to plane-wave 2,450-MHz CW microwaves for 3 months at a flux density of $500 \mu \text{ W/cm}^2$. The animals were observed during or after the 3-month period for activity, for acquisition of an avoidance habit, and for sensitivity to electric shock to the feet. Reliable differences were observed in these behavioral end points that correlated well with changes in serum electrolytes (Na^+ , K^+ , carbon dioxide content, and ion gap). The changes observed in irradiated animals subsided within a month after cessation of exposures; this could be taken as evidence of reversible influence by the $500\text{-} \mu \text{ W/cm}^2$ field.

NEUROENDOCRINOLOGIC EFFECTS

The hypothalamus can be regarded variously as a collection of homeostats, as the "head ganglion" of the autonomic nervous system, and as the primary source of nervous-system input into the endocrines. It is largely in its last-named role that studies of the endocrinologic response to microwave radiation have been performed. The hypothalamus is a continuous sensor of influences especially from thalamic and cortical structures and from fibers of both spinal and extraspinal origin. Blood vessels carry a constant stream of chemical messages from the hypothalamus to the endocrines about external and internal factors that affect the body's function. The hypothalamus is thus a master regulator. Endocrinologic changes observed in the intact organism during or after exposure to microwaves must be understood in this context.

The "general adaptation syndrome" of Hans Selye provides a convenient framework within which to understand the neuroendocrinologic responses to stress. Intense, sustained microwave irradiation shares with other sources of prolonged stress the evocation of an alarm reaction, development of resistance, and if intense exposure continues, exhaustion and death,^{101,133} presumably from thermal stress.

At least three systems involving the hypothalamus with the endocrines are implicated in the response to stress: the hypothalamic-pituitary-adrenocortical (HPC) system, the hypothalamic-pituitary-thyroidal (HPT) system, and the sympathoadrenomedullary (SAM) system. The hypothalamus is also believed to regulate growth hormone.¹¹⁵

Most of the research performed on the neuroendocrines has involved short-term exposures of the albino rat to moderate- or high-intensity irradiation (1-60 mW/cm², typically for less than 2 h at 2,450-MHz CW in the far field). Stimulation of the HPT system resulting in an increase in thyroxine content occurs at power densities that result in measurable increases in body temperature.¹⁰³ Stimulation of the HPC system has been reported after irradiation at 50-60 mW/cm² for various periods in which colon temperatures are increased by 1-3°C, but the response is "equivocal" at power densities between 30 and 40 mW/cm². The primary indicant of HPC-system activation is increased serum titer of corticosterone (CS). More recent studies have confirmed that CS titer is strongly and positively related to increased body temperature, which in turn is strongly conditioned by intensity (20-40 mW/cm²) of the incident field, at least during relatively short exposures (less than 2 h).^{99,101} When, however, rats were exposed once for 8 h to a field at 20 mW/cm², serum CS content was decreased.¹⁰¹ Because the CS content is an index of the severity of stress, as well as of the progression of the general adaptation syndrome, one might interpret these data as evidence that irradiation at 20 mW/cm² does provoke the alarm reaction, but that the stage of resistance develops quickly. Alternatively, the decline in CS titer below control values might be evidence of incipient entry into the stage of exhaustion. That the latter interpretation is unlikely is inferred from other data¹¹³ on rats that were exposed for 10 h/day for 3 weeks to 918-MHz multipath radiation that approximated 10 mW/cm². Basal serum CS content did not differ between irradiated and sham-irradiated rats at the conclusion of irradiation treatments.

In other studies¹⁰⁹ of rats exposed once to 2,450-MHz plane waves at 36 mW/cm² for 90-150 min, growth hormone (GH) was decreased. Whether GH decrease is an acute response or a prolonged sequela of microwave exposure is an unanswered question, but one of considerable interest, in the light of conflicting reports¹⁰⁴ that decreased or even increased body mass is a consequence of acute or chronic in utero exposure to microwaves.

The lowest power density at which endocrinologic changes have been reported in the eastern literature is 1 mW/cm²; serum thyroxine was transiently increased in irradiated, but not in sham-irradiated, rats after a 4-h treatment with 2,450-MHz microwaves.¹⁰¹

In none of the studies cited were irreversible changes observed, but the dearth of endocrinologic assays of animals that undergo truly long-term exposures to microwaves or other RF radiation precludes assessment of chronic effects of fields of low power density (less than 1 mW/cm²) or moderate power density (less than 10 mW/cm²).

IMMUNOLOGIC EFFECTS

Immunologic and hematologic responses to exposure to microwaves have recently been reviewed.⁸⁷ This section summarizes that review.

Extensive research on the effects of microwave radiation on the mammalian hematopoietic system and its constituents has been carried out, particularly by Eastern European investigators. Kicovskaja (1964, cited in Baranski and Czernski¹²(p. 137)) irradiated rats for 1 h/day for 216 days with 10-cm microwaves at power densities of 10, 40, and 100 mW/cm². Evidence of lymphocytosis, of lymphopenia, and of a slight decrease in the number of red blood cells was found at power densities equal to or greater than 40 mW/cm². Deichmann et al.,³⁹ in contrast, reported evidence of neutrophilia, lymphopenia, and increased numbers of red blood cells in rats after single and repeated exposures (for 10 min to 7.5 h) to 1.25-cm microwaves at power densities of 10-24 mW/cm².

Baranski¹¹ exposed large numbers of guinea pigs and rabbits to 10-cm radiation at power densities of 3.5-7 mW/cm² for 3 h/day. Overall durations of the intermittent exposures ranged from 2 weeks to 4 months, and both continuous and pulsed waves were used. After 2-3 months, the exposures resulted in leukocytosis due entirely to increased numbers of lymphocytes; there was no effect on the number of granulocytes. Bone-marrow examination revealed no significant changes in the myeloid:erythroid ratios, but there was a marked decrease in both pronormoblastic and basophilic normoblastic populations of cells and a shift to more mature forms. The mitotic index of the erythrocyte series of cells, determined after administration of colchicine, was severely decreased in microwave-exposed animals. Pronounced mitotic changes were also noted in the nuclei of normoblasts, but no such effects were seen in precursors of granulocytes. Examination of lymph-node and spleen-impression smears revealed a marked

increase in lymphoblasts and in reticular cells, and abnormalities of nuclear structure were observed that were similar to those observed in normoblasts. After termination of the irradiation, the blood characteristics gradually returned to normal. The data in Baranski's report appear to indicate a stimulation of the lymphoid system, the response being much more pronounced to pulsed than to CW radiation.

Miro et al.¹¹¹ exposed mice for 150 h to pulsed, 10-cm microwaves at nearly 20 mW/cm²; the authors reported an apparent stimulatory effect of irradiation on the reticulohistiocytic system. They made their determinations by histologic analyses and by observing uptake of [³⁵S]methionine into proteins of liver, spleen, and thymus.

Czerski et al.³⁶ exposed guinea pigs for 4 h/day for 14 days to 2,950-MHz pulsed microwaves at a power density of 1 mW/cm². These daily exposures were either at 8 a.m. or at 8 p.m., to permit study of possible alterations in the circadian rhythm of bone-marrow mitoses, determined after the arrest of mitosis by colchicine. No effects were seen on precursors of granulocytes, and only minimal effects on the erythrocyte series, but pronounced phase shifts were noted in the pool of stem cells. Included in the latter category were early normoblasts, myeloblasts, lymphoblasts, and other unidentified blast cells. The study was then extended; a large group of inbred Swiss albino mice were exposed once for 4 h at 0.5 mW/cm² to pulsed 2,950-MHz microwaves-- a frequency at which the mouse exhibits resonant absorption of microwaves. Another group of mice were used to determine body temperature immediately after comparable exposures. No significant increases in body temperature were found during the 4-h exposure. The results of the study on mice were similar to those of the experiment on guinea pigs. The diurnal rate of proliferation of the stem-cell population of exposed animals was amplified, and the phase shifted from that of controls. In another study, the investigators exposed rabbits daily for 2 h (for a total of 74 or 158 h) to 2,950-MHz pulsed or continuous waves at 3 mW/cm² and found an impairment of red-cell production, determined by ferrokinetic studies;³⁵ the effects of pulsed waves were more pronounced than those of CW radiation.

The finding of shifts in the circadian rhythm of the blood-forming system at power densities near 1 mW/cm² is a physiologic indicant of responsiveness to relatively weak microwave fields. A similar phase shift in the circadian rhythm of body temperature was observed by Lu et al.¹⁰¹ in rats exposed at 1 mW/cm² to 2,450-MHz radiation for 1-8 h. The implications of such field-induced shifts, which represent perturbations of the biologic clock, are not clear, but are reminiscent of the work of Wever,¹⁵⁹ who argued that man-made electromagnetic radiation can interfere with "natural" fields of solar and terrestrial origin that he postulated to be regulators of circadian biologic rhythms.

A number of recent studies have been focused directly on immunologic effects of microwave irradiation. Paradoxically, enhanced immunologic

competence is often reported in association with radiation at power densities above 10 mW/cm^2 (see, e.g., Luczak et al.,¹⁰² Szmigielski et al.,^{143,144} and Wiktor-Jedrzejczak et al.^{101,102}) and includes increased phagocytic activity, increased population of complement-receptor-bearing lymphocytes, and augmentation of antiviral responses. In contrast, Shandala and colleagues¹³⁶ reported that a month of daily 7 h exposures of rats to microwave radiation at much lower power densities, near $500 \mu\text{W/cm}^2$, resulted in impaired immunologic competence and induction of autoimmune disease.

GENETIC, TERATOLOGIC, AND DEVELOPMENTAL EFFECTS

The genetic effects of exposure to microwave and RF radiation have been investigated at several frequencies and over a range of field intensities in both animal and plant systems. Mutagenic effects and effects on growth and development have been reported to be induced in experimental animals exposed to microwave field intensities of 5 mW/cm^2 or greater.^{28,40} Exposure to low-intensity microwave fields (i.e., less than 1 mW/cm^2) has not been shown to result in genetic or developmental alterations in biologic systems. In the few epidemiologic studies that have been performed, either there has been no reported association between exposure and morbidity or, in the case of one study of the incidence of Down's syndrome in the progeny of men who were potentially exposed to microwave radiation, a positive association reported in an initial study was not corroborated in a later study.³³

Microwave irradiation at high (thermal) intensities has been shown to exert a teratogenic effect in insects that differs qualitatively from effects due to nonmicrowave heating. It has been suggested that the extent of teratologic damage depends more on the total exposure dose than on the microwave field intensity and that such effects are due to field interactions at the microstructural level.¹¹⁸ Although the teratogenic effects of microwave exposure do not appear to depend solely on the average temperature increase in the test systems, such effects have not been demonstrated to result from low-field-intensity exposures.

OCULAR EFFECTS

Of the many purported effects of microwave exposure, cataract induction is the only irreversible alteration reported to have occurred in humans as a result of accidental overexposure.²⁸ In general, accurate reconstruction of the exposure conditions that have resulted in cataract induction has not been possible. Thus, there is some uncertainty in the interpretation of the ocular effects of microwave exposure. But there is no indication that low-field-intensity microwave exposure results in cataract induction or other ocular pathology. This statement is consistent with the results of animal experimentation, which have yielded

intensity-duration thresholds for cataract induction for acute exposures,⁷⁰ Acute exposure of rabbits to field intensities of greater than 100 mW/cm² for duration of greater than 1 h has been shown to result in cataract induction. Repeated exposures at field intensities that were below the threshold for cataract induction for single exposures have been reported to result in cataracts, but again the exposures were at about 100 mW/cm².²⁵ Although there are uncertainties regarding the detailed mechanism of microwave cataract induction, as well as the dependence of this effect on radiation frequency and other field characteristics, it is generally assumed that microwave cataracts are a result of thermal damage to lens tissue and thus that they do not appear to constitute a problem in the case of prolonged exposures to field intensities of less than 10 mW/cm².

REPORTED HUMAN EFFECTS

Reports of human effects of microwave radiation are derived almost exclusively from surveys of workers who were occupationally involved in the fabrication, use, and repair of microwave equipment. Such surveys may be divided into two groups: broadly based general surveys in which a variety of biologic-physiologic responses in exposed and nonexposed (control) groups are assessed and surveys designed to detect effects-- e.g., ocular, cardiovascular, auditory, teratologic, gonadal, and genetic-- in specific organ systems. A few individual case histories of human exposure are also available.

A representative number of such surveys have been reviewed to identify those with possible relevance to the radiation conditions produced by the pulse-modulated signals of the PAVE PAWS radar. Unfortunately, the identity and operational characteristics of most of the sources of the microwave fields mentioned in these surveys are not specified. Furthermore, the radiation fields produced by the many different microwave sources in given work environments are often generalized into expressions of averaged power density, without reference to the radiation frequency or waveform. The difficulty of applying such generalized information to the specific environmental radiation conditions produced by PAVE PAWS becomes immediately apparent.

Although a broad attempt is made here to examine representative literature on reported effects in humans, particular attention is given to reported effects at exposures of approximately 1 mW/cm² and below, because the PAVE PAWS may be expected to produce accessible radiation well below this.

GENERAL SURVEYS

There have been a number of studies of personnel who were routinely associated with the operation of microwave-generating equipment or who were present in areas where microwave-radiation exposure was possible.

As a result of long-term observation of microwave workers who presumably were exposed to a wide variety of CW and pulsed fields, Gordon⁶² concluded that prolonged exposure to centimeter-wavelength radiation at power densities of about 0.1-10 mW/cm² would produce marked disturbances in cardiac rhythm, such as bradycardia, and persistent hypotonia. Prolonged exposure (years) to centimeter and millimeter wavelengths at power densities of 0.01-0.1 mW/cm² reportedly produced the same symptoms as occurred in the higher-exposure group (0.1-10 mW/cm²), but the symptoms were less evident and were reversible. Gordon suggested that chronic exposure to microwaves may lead to the development of a so-called neurocirculatory syndrome. This syndrome reportedly occurs in three stages. The first stage consists of "lability" of cardiac rhythm and blood pressure, both of which are reversible. The second stage is an accentuated form of the first, with EEG changes, thyroid hyperactivity, and an "asthenic state" (headaches, excitability, irritability, fatigue, and pains in the cardiac region). The third stage consists of symptoms that are identical with but more pronounced than those of the first and second stages, with electrocardiographic (ECG) changes.

Although Soviet investigators believe that years of exposure to power densities of 0.01-0.1 mW/cm² can produce effects in humans, the effects appear to be minimal or reversible. However, a major difficulty with these studies is the lack of specification of the modulation characteristics of the microwave sources. The low-intensity pulse-modulated radiation from the PAVE PAWS radar is of primary interest here, and the direct applicability of the Soviet studies to PAVE PAWS is questionable.

Personnel engaged in the use, repair, and production of microwave sources were studied by Baranski and Edelwejn.¹³ They were divided into low-, moderate-, and high-exposure groups. The designation of "low exposure" usually means average values of "tens of microwatts per square centimeter" in the Polish literature; "moderate exposure" usually means average values of "hundreds of microwatts per square centimeter up to one milliwatt per square centimeter"; and "high exposure" usually means "average values above one milliwatt per square centimeter up to ten milliwatts per square centimeter." Maintenance, repair-shop, and factory personnel were assigned to the high-exposure group. Each of the three groups was subdivided into five categories on the basis of number of years of work associated with microwave sources. Source characteristics (CW, pulse) were not specified. According to the authors, subjective complaints of headaches and sweating were frequent, and personnel with the longest occupational-exposure histories had relatively flat EEG recordings; but no firm conclusions could be drawn, owing to the complexity of environmental and occupational factors and the lack of adequate control groups. An additional difficulty with the study was the lack of definitive environmental-exposure data.

The Eastern Europe literature contains many references to what is called a chronic "overexposure syndrome."^{110,124} This syndrome is

said to consist of general irritability and complaints of headache, weakness, sleeplessness, decrease in libido, and pains in the chest among those exposed to low-intensity microwave fields. The syndrome is reportedly characterized by periodic recurrences of the same symptoms with intermediate periods of adaptation. However, a more recent appraisal¹² concluded that a microwave-overexposure syndrome remains to be demonstrated.

Czerski (in Baranski and Czerski¹²) described the cases of two long-term radar technicians who were accidentally exposed to microwave power densities of 30-70 mW/cm². These power densities are presumed to represent average values, inasmuch as no peak-power characteristics were mentioned. In the first case, exposure lasted for about 20 min, and in the second, about 5 h. There were no abnormal findings in either subject in followup studies 1 month, 6 months, and 1 yr after the exposure.

Baranski and Czerski¹² report on a study of several thousand Polish microwave workers who received low, moderate, and high exposures to microwave radiation. The group exposed to low power densities (average, tens of microwatts per square centimeter) was designated the "E" group, the group exposed to moderate power densities (average, hundreds of microwatts per square centimeter up to approximately 1 mW/cm²) was designated the "ES" group, and the group exposed to high power densities (average, 1-10 mW/cm²) was designated the "R" group. No adequate control group was found, because of difficulties in finding persons of the same age working under sufficiently similar environmental, social, and economic conditions. The E group did not have any symptoms after 10 yr of work. Headaches and fatigue disproportionate to effort reportedly occurred in approximately 45% of those in the R group, in 32% in the ES group, and in 30% in the E group during the first year of work. There is no indication as to whether the differences among these percentages are statistically significant. Reportedly, the aforementioned symptoms disappear for 2 yr, recur when an employee has worked for 3-5 yr, and then may reappear in some employees after 5-10 yr of work. Changes in blood pressure reportedly occurred only in the R group. No correlation of heart rate with exposure could be demonstrated; and no ECG changes were found. After 10 yr of work, 10.5% of the R group workers reportedly had absolute lymphocytosis, usually accompanied by monocytosis, the total WBC being over 10,000/mm². After long-term exposure, the ES and R groups reportedly had a decrease in the number and amplitude of alpha waves and an increase in the threshold of stimulation of the senses. The exposures assigned to each group can be interpreted to mean average values produced by a multiplicity of sources, whose individual characteristics (e.g., CW or pulse-modulated) are unidentified.

A study^{38,139} of 841 radar shopworkers and installers attempted to determine whether any differences in functional disturbances might exist between a group of 507 persons exposed to mean power densities above

0.2 mW/cm², but not exceeding 6 mW/cm²* and a group of 334 persons exposed to mean power densities below 0.2 mW/cm². The pulse-modulation characteristics of the microwave sources were not reported. Functional disturbances were classified as neurotic syndrome (headaches, sleep disturbances, excessive fatigue, emotional instability, difficulties in ability to concentrate or memorize, tremor of hands, sweating, etc.), digestive tract complaints, and cardiocirculatory (including ECG abnormalities). The difference in exposure between the two groups had no apparent effect on the incidence of functional disturbances, nor did the duration of exposure. However, the incidence of the reported functional disturbances was related to the age of the workers. The findings of these studies do not support the hypothesis of cumulative effects of microwave exposure with increasing duration of exposure, at power densities up to 6 mW/cm². The question of the causal relationship between exposure to microwave radiation and the reported functional disturbances should be "left open," according to the authors.

A study of some 1,800 employees and more than 3,000 of their dependents who spent time in the U.S. Embassy in Moscow concluded that there was no convincing evidence that microwave radiation had any adverse health effects.⁹⁶ Special care was taken to elucidate specific limitations of this epidemiologic study. For example, the identified exposed population in Moscow was too small for the detection of excess risks that were less than twofold for many of the medical conditions studied, except the category "total malignant neoplasms." The health status of the study participants was determined by questionnaire: 59% of those in Moscow study (exposed) group completed questionnaires, and 48% of those in the comparison group, who served at other Eastern European posts. A modest amount of information was available on environmental exposures in various locations in the U.S. Embassy; therefore, a degree of exposure could be assigned to employees who had worked at the embassy earlier if they could recall the exact locations where they had worked.

For some unexplained reason, the ratio of the number of deaths due to cancer to the total number of deaths among females employed in the Moscow Embassy (8 cases of 11) during the study period was higher than that in the female comparison group serving in other Eastern European posts (14 of 31). However, no significant difference in total mortality or mortality due to cancer was found in comparisons between the employee group at the Moscow Embassy and those serving at the other Eastern European posts.

Some complaints of depression, irritability difficulty in concentrating, and memory loss were elicited during the study, but the persons in the Moscow Embassy group who registered a greater incidence of such complaints than those in the comparison (control)

*The report stated that the power density in the work environment sometimes briefly exceeded 6 mW/cm².

group were the persons who received the lowest exposure to microwaves among the exposed Moscow group. The power densities in the Embassy were reported as approximate maximums that a person could have received by remaining directly in the beam for the entire period of transmission. For the period 1953 through May 1975, the maximal exposure at any point in the Embassy was $5 \mu\text{W}/\text{cm}^2$ --an intensity that existed for no longer than 9 h/day. From June 1975 to February 7, 1976, the maximum at any point was $15 \mu\text{W}/\text{cm}^2$, and the maximal time of beam transmission was 18 h. Beginning on February 7, 1976, the maximum was less than $1 \mu\text{W}/\text{cm}^2$, for a maximum of 18 h. Maximal microwave intensities were measured at the outer walls and windows; considerably lower values were found at points away from the windows. In general, the exposure of any given person was much less than the maximum cited ($15 \mu\text{W}/\text{cm}^2$). The microwave source was broad-band (0.5-10 GHz), with the highest power density between 2 and 3 GHz.

The medical records of a group of U.S. Navy electronics technicians, fire-control technicians, and aircraft electronics technicians--presumably exposed to various amounts of microwave energy during the course of their military assignments--were compared with the medical records of a control group of radiomen, radarmen, and aircraft electrician mates, who presumably received little or no exposure. The assertion that the latter group is a "control" or unexposed group is open to serious question. A small but significantly greater incidence in mortality due to trauma was evident in the exposed group, but there was no significant difference between the two groups in total mortality or mortality from specific diseases--cardiovascular disease, malignant neoplasms, vascular lesions of the central nervous system (strokes), arteriosclerotic heart disease, chronic nephritis, cirrhosis, pneumonia, and leukemia.¹²⁹ Major difficulties with this study include the absence of data on environmental exposure and on exposure time patterns of personnel and the absence of a valid control (nonexposed) group.

One death was alleged to have been due to microwave exposure,^{105,106} but the allegation is generally regarded as unproven.⁴³ Exposure to radiation allegedly occurred from a high-power radar and resulted in necrosis of the stomach and fatal hemorrhage.

There is no known proven case of human mortality due to chronic exposure to microwave radiation.

OCULAR EFFECTS

Cataracts have been produced in experimental animals exposed to microwave radiation. Although there is no fundamental reason to assume that cataracts cannot be similarly produced in humans, the lack of positive proof of microwave induction cataracts in man has led to considerable controversy.

A number of retrospective studies have been undertaken to determine whether a group of persons more likely to have been exposed to microwave radiation developed more cataracts or other ocular abnormalities than a control group with no conceivable exposure to microwaves. In some of these studies,^{30,166} a somewhat greater incidence of lenticular imperfections was noted in the microwave workers than in the control groups. Employees in a Swedish radar-equipment facility had a higher incidence of lenticular opacities than the control group.⁹ In the same study, 17 of 50 potentially exposed subjects had retinal lesions. Whether microwave radiation can produce retinal lesions is questioned by many investigators, but no definitive study has been conducted.

The results of a study of ocular effects among 507 men exposed to microwave at power densities of 0.2-6 mW/cm² did not differ from those of a study of 334 men exposed to a mean of less than 0.2 mW/cm².¹³⁸ No correlation was demonstrated between the incidence of various grades of lenticular translucence and the duration of exposure to the aforementioned radiation, but a clear-cut dependence on age was demonstrated. In a study of possible microwave induction of lenticular changes in U.S. Air Force personnel, Shacklett *et al.*¹³⁵ found no statistically significant difference in the incidences of opacities, vacuoles, and posterior subcapsular iridescence (PSI) between 447 exposed subjects and 340 control subjects. Similarly, Appleton and colleagues,⁴⁻⁶ on the basis of examination of some 1,500 military personnel working with microwave equipment, concluded that there were no differences in lenticular opacities, vacuoles, or PSI between microwave workers and unexposed persons of comparable ages.

A number of individual case histories of microwave induction of cataract have been reported,^{77,91,137} but in no case, is there reason to suspect that the exposures were not well in excess of 100 mW/cm². One study³² of possible relevance to PAVE PAWS hints at a lessening of cataractogenic efficiency at the comparatively low frequencies used in the investigation of cataract induction--200, 385, and 468 MHz.

In some Soviet investigations of microwave workers (for example, Gordon⁶²), increased incidence of lenticular opacities and sporadic cases of cataract were mentioned, but no firm conclusions were drawn about an association between exposure and cataractogenesis. Furthermore, other Soviet investigators (see Petrov²⁴) doubted the causal relationship of lenticular imperfections and microwave exposure. The implication in the Soviet work is that lenticular imperfections and cataracts can occur only if exposures are far in excess of the USSR standards, presumably around 10 mW/cm² or more.¹²

Zydecki¹⁶⁸⁻¹⁷⁰ examined lenticular transparency in 542 microwave workers whose exposure was supposed to be limited to 0.1-1 mW/cm², but who reportedly received much higher exposures. Baranski and Czernski¹² estimated that the actual exposures probably were in the range of 1-10 mW/cm² for 4 h/day, on the average. One conclusion of the Zydecki work was that microwave exposures may cause acceleration of the aging processes of the lens.

Zaret^{163,165} reported on more than 50 cases of lenticular changes that he believed characteristic of microwave-radiation exposure. Reported preclinical changes consisted of a roughening and thickening of the polar region of the posterior capsule accompanied by the presence of minute areas of opacification and eventual capsular opacification. Other ophthalmologists have been unable to corroborate these diagnostic criteria. Another difficulty with the Zaret reports is the absence of exposure data to compare with the clinical findings.

More recently, Zaret and Snyder¹⁶⁷ have reported on nine cases of cataracts induced by hertzian radiation among personnel working in aviation environments where they were irradiated at power densities below 1 mW/cm^2 . The nine subjects were three radar technicians, five air-traffic controllers, and one airline pilot. At the time of clinical examination, the ocular lesions had reportedly progressed to capsular cataract, vesiculation, and opacification of the proximal subcapsular lenticular substance. According to the authors the slit-lamp examination revealed signs of honeycomb capsulopathy, the earliest clinically recognizable state of "hertzian radiation cataractogenesis." The lack of definitive exposure histories leaves serious doubts that a casual relationship has been established.

One Eastern European study of long-term exposure of workers to power densities at or below 1 mW/cm^2 concluded that such exposure does not result in any "reliable deviations of ocular sensitivity."⁵¹

CARDIOVASCULAR EFFECTS

Edelwejn *et al.*⁴² concluded in 1974 that no serious cardiovascular disturbances had ever been produced in man or experimental animals by exposure to microwave radiation. Experience after 1974 has tended to support this conclusion, but no definitive work can be claimed. Zaret¹⁶⁴ offered the hypothesis that microwave radiation was responsible for the high incidence of heart disease in North Karelia, Finland, but later reports^{126,156} have cited the longstanding concern of public-health authorities over the high-cholesterol diet and obesity of residents as the causal factors.

As cited earlier, Gordon⁶² claimed that prolonged exposure (for example, to microwave radiation at wavelengths of centimeters and millimeters and at average power densities of $0.1-10 \text{ mW/cm}^2$) can produce marked disturbances in cardiac rhythm (bradycardia) and hypotonia. However, Czernski and Siekierzynski³⁷ reported that blood pressure of workers routinely exposed to power densities less than 1 mW/cm^2 did not differ significantly from that of unexposed control subjects.

Bielski *et al.*²² claimed that exposure to power densities of 1 mW/cm^2 or less may result in "slight but significant cardiovascular alterations" after 10 yr of exposure. However, the exposed workers had a higher resistance to stress.⁸⁶ On the basis of available evidence,

the probability is very low that low-intensity microwave radiation has adverse cardiovascular effects on exposed humans. The long-term low-intensity effects reported in some Eastern European publications have no discernible application to exposure conditions associated with the operation of PAVE PAWS.

AUDITORY EFFECTS

Humans can perceive pulse-modulated electromagnetic energy as sound. The perceived loudness is related to the peak power, not the time-averaged power density. There is strong evidence that the microwave-induced auditory response is due to a mechanical disturbance, rather than a direct effect on the central nervous system.^{68,97}

The threshold for microwave-induced auditory responses appears to be related to the incident energy per pulse. For humans, the threshold is approximately $40 \mu\text{J}/\text{cm}^2$ for pulse durations of less than $30 \mu\text{s}$. This corresponds to an absorbed energy per unit mass of approximately $16 \text{ mJ}/\text{kg}$ for the human head. Of particular interest is the fact that the theoretical temperature rise for a single pulse is only $5 \times 10^{-6} \text{ }^\circ\text{C}$ in the irradiated tissue.⁶⁸ Therefore, the temporal characteristics of the pulse and the temporal characteristics of temperature change, albeit minuscule, appear to be the important factors.

Given the operating characteristics of PAVE PAWS, it is possible, although unlikely, to experience an auditory response. However, there is no evidence that such an exposure would constitute a hazard to health.

GONADAL EFFECTS

One report⁹³ claimed that 22 of 31 microwave technicians experienced loss of libido and reduced spermatogenesis after an average of 8 yr of exposure to microwave radiation frequencies between 3.6 and 10 GHz at power densities ranging from tens to hundreds of microwatts per square centimeter. Both libido and spermatogenesis returned to normal in most of the technicians 3 months after cessation of microwave exposure.

There are no reports of irreversible testicular damage in humans at power densities below $1 \text{ mW}/\text{cm}^2$.⁸⁶

The only reported case of injury to the reproductive system caused by the clinical use of microwave radiation involved diathermy treatment of a fallopian tube, with power densities of approximately $100 \text{ mW}/\text{cm}^2$ or greater.³⁴

TERATOLOGIC EFFECTS

A series of 20- to 60-s exposures of gravid mothers to power densities that probably exceeded 100 mW/cm^2 occurred over many years in the clinic of Jose Daels, a Belgian obstetrician. In a personal communication to D. R. Justesen dated January 2, 1978, Dr. Daels reported that more than 10,000 deliveries had been performed with microwave diathermy. Observation of the children had never revealed a harmful effect.⁸⁶

OTHER EFFECTS

There is no evidence of significant microwave-induced immunologic, cerebrovascular, or genetic effects in humans, although well-designed studies of sufficiently large groups have never been carried out.

DISCUSSION

In general, large-scale epidemiologic studies of populations exposed to microwaves have not been conducted. Selected groups of microwave workers (typically less than 1,000 in a group) have been monitored after their initial involvement with microwave sources, but information on the baseline status of their health before employment in a microwave environment (e.g., preplacement medical examination) is often not available, nor are precise data on exposure history (e.g., radiation power densities and exposure time patterns) or information on the extent or anatomic distribution of absorbed energy. It is common to make gross estimates of the average power density in the work area without attempting to characterize the radiation field. The importance of such factors as scattering, radiation frequency, and the presence of a near or reactive field in describing the exposure environment is well known. An overriding difficulty with the literature on human effects is the lack of information on the modulation of pulsed-microwave sources. Indeed, such information may be crucial to a determination of potential biologic effects associated with exposure to radiation at 1 mW/cm^2 or less (PAVE PAWS). The fact that the available exposure data are almost exclusively in terms of average (rms) power density reflects earlier times, when the biologic importance of modulated signals was relatively unappreciated. Therefore, it may be concluded that most of the available information on human effects has questionable applicability to PAVE PAWS.

The Eastern European literature is replete with references to effects on the central nervous system (CNS) caused by low-intensity microwave exposure. However, most of the publications contain relatively few measurements of CNS functions themselves; rather, effects (usually behavioral) are reported and are inferentially regarded as direct effects on the nervous system, e.g., neurasthenic syndrome.

There is an obvious need to determine more precisely the degree of involvement of the CNS when people are subjected to low-intensity microwave radiation.

The Eastern European literature (e.g., Gordon⁶²) consistently points out the difficulties of separating the reported biologic effects attributable to microwave exposure from the biologic effects that may result from other factors in the work environment, such as noise, ambient temperature, humidity, illumination, frequent separation from one's family, or isolation from large population centers when servicing or operating microwave equipment in remote areas. Distinguishing the effects of microwave radiation from those of other factors is more difficult when exposure to low power densities (1-5 mW/cm² or less) is involved. Even in the case of radar workers who are exposed to little or no microwave radiation, there are complaints about eye fatigue headaches, bradycardia, hypotonia, and general fatigue. Gordon⁶² believed that such symptoms may be attributable to illumination that is less than optimal or to the need to stare at video terminals (cathode-ray-tube displays) for long periods. The difficulty of distinguishing signs and symptoms attributable to microwave exposure from those due to alcohol consumption, smoking, overwork, or obesity must also be noted.⁶⁵

Although most investigators have attempted to control experimental variables so that discernible differences in individual responses could be attributed exclusively to microwave radiation, there is still appreciable uncertainty in attempts to control such factors as motivation, personality characteristics, tolerance to assigned work tasks, personal problems, and anxiety. All these could have a major effect on the incidence of headaches, irritability, and restlessness in study participants.

The Johns Hopkins finding⁹⁶ of complaints of headache and irritability in U.S. Embassy employees and dependents were remarkably similar to, if not identical with, the neurasthenic syndrome reported by Eastern European investigators, but the Embassy people were only occasionally exposed to microwave radiation and the exposures were in general appreciably below 5 μ W/cm². Questions therefore remain as to the suitability of present methods for detecting subtle changes in groups of people exposed (and unexposed) to microwave radiation of low power density. An associated difficulty is related to the failure of almost all the published epidemiologic studies to specify the analytic limitations of their techniques.

There is substantial evidence that cataracts can have a thermal origin. A threshold effect has been demonstrated: irradiation of the eyes of animals at 100 mW/cm² or greater is required for cataract induction. Although lenticular changes have been discovered in groups of microwave workers, a cause-and-effect relationship between the reported defects and microwave radiation has not been conclusively demonstrated. Considering the radiation frequency and expected power densities associated with PAVE PAWS, the possibility of induction of cataracts in exposed members of the public is very small.

The effects of long-term exposure to microwave radiation at low power densities (e.g., less than 1 mW/cm²) have not been adequately assessed. There is no evidence of a cumulative effect on humans, but the question is unresolved.

Taking the literature on reported human effects as a whole and considering the nature and weight of available evidence, as well as the limitations of the investigative techniques used, the Panel believes that the probability of adverse biologic effects on persons exposed to radiation from PAVE PAWS is very low under normal operating conditions and that such effects would be expected to be subtle, transient, and reversible.

Additional research is recommended to clarify further the possible effects of long-term exposure to microwave radiation at low power densities.

CHAPTER 3

SUMMARY AND CONCLUSIONS

On the basis of available information, the maximal instantaneous microwave-field intensities anticipated in areas of public access in the vicinity of PAVE PAWS during normal operation of the existing radar should be about $100 \mu\text{W}/\text{cm}^2$. The corresponding time-averaged intensities as measured under normal operating conditions have been found to be lower by at least two orders of magnitude. A comparison of these time-averaged potential exposures with exposures resulting from other commercial, private, and military sources of microwave and radiofrequency radiation does not indicate any substantial variation from power densities to which segments of the general public are routinely exposed in some localities. PAVE PAWS, therefore does not appear to present unique exposure conditions with respect to the anticipated time-averaged field intensities.

Although no overt deleterious health effects have been documented to result from such low-intensity exposure of the public, statistically designed epidemiologic studies have not been conducted. It is therefore not possible to conclude, on the basis of a comparison of time-averaged exposure intensities, that effects will or will not be induced by exposure to the radiation from PAVE PAWS.

A review of experimental and epidemiologic studies of occupationally exposed workers indicates that both humans and experimental animals have been reported to be sensitive to microwave exposure intensities of about $1 \text{ mW}/\text{cm}^2$ or greater, the nature of the effects depending on a large number of physical and biologic factors, most of which are inadequately understood. Documented effects on morbidity or mortality, most of which have been observed in experimental animals, are generally associated with exposure intensities over $10 \text{ mW}/\text{cm}^2$ and attributed to excessive thermal stress. Possible exceptions, however, are alterations in central-nervous-system function and immunologic status, in both experimental animals and humans, that have reportedly occurred at about $1 \text{ mW}/\text{cm}^2$. Alterations in CNS function include objective findings, such as changes in EEG patterns that have been reported to occur from occupational exposure of humans for periods of years or from acute microwave exposure of experimental animals at intensities of $1 \text{ mW}/\text{cm}^2$ or greater. Subjective alterations in mood and behavior have also been reported in occupationally exposed microwave workers, and specific behavioral end points in experimental animals have reportedly been affected by microwave exposure at intensities of $1 \text{ mW}/\text{cm}^2$ or greater. The subtle and subjective nature of the reversible effects in humans makes it difficult to establish quantitative relationships to exposure conditions.

In vitro and in vivo exposures of nervous tissue have provided additional evidence of sensitivity to low-intensity microwave fields. Effects have been reported to occur in specific ranges ("windows") of

intensity and pulse repetition rate, whose existence suggests that alterations in nervous tissue may not depend solely on exposure intensity or duration; i.e., such effects do not follow monotonic dose-response relationships. Although the physiologic significance of in vitro findings has not been established, their existence, with the in vivo findings of sensitivity of the mammalian CNS to microwave and weak electric and magnetic fields, suggests altered CNS function as a subject of greatest potential concern with respect to low-intensity microwave exposure from PAVE PAWS. Owing to the limited scope and extent of studies of the biologic effects of chronic low-intensity microwave exposure, it is not possible to conclude that other types of physiologic effects will not be induced in humans. But there is no evidence to suggest that other types of physiologic alterations should be anticipated as a result of exposure to PAVE PAWS radiation in areas of public access.

There are no data on the biologic effects of microwave radiation with the specific characteristics of the PAVE PAWS radar, which, because of its rather unusual function, differs from more commonly encountered sources of microwave and RF radiation. The inherent problems of interspecies, interfrequency extrapolation limit the extent to which existing data may be used to assess the effect of PAVE PAWS radiation. Data from both in vivo and in vitro studies suggest maximal sensitivity of neural systems to fields modulated at mammalian brainwave frequencies (i.e., 1-20 Hz), which include the predominant PAVE PAWS modulation frequency at 18.5 Hz. Because of the aforementioned possibility of field-intensity windows and the lack of adequate data on mammalian systems, it is not known whether such effects will be induced in humans under the anticipated exposure conditions. During normal operation of PAVE PAWS, the direction of the radar beam will be continuously varied in the scanning mode, so exposure at a given location will be intermittent and at low time-averaged intensities, relative to the intensities associated with irreversible biologic damage. The effects of such exposures of members of the public, if they occur, will, on the basis of available data and the known interaction mechanisms with biologic systems, be reversible or transient. Thus, the possible exposure effects of PAVE PAWS should be restricted to transient, reversible functional alterations in the CNS that may or may not be perceived by the exposed persons.

Whatever the effects of exposure on the human central nervous system are, it is not known whether the effects are deleterious to health. It has not been established, for example, that such effects involve impairment of judgment or alterations in mood that would impose psychologic or physiologic burdens on those affected.

The microwave radiation from PAVE PAWS may present interference problems with electronic devices in the vicinity of the radar site. The design characteristics of device like electromagnetically shielded cardiac pacemakers are such that their operation should not be adversely affected by PAVE PAWS exposure intensities, but some pacemakers currently in use may be affected by exposure. There should not be any important deleterious consequences due to exposure of persons with surgical implants

or other prosthetic devices. Interference with other electronic devices, such as television and radio receivers, is beyond the scope of this report, but obviously must be taken into account. Special attention should be given to the evaluation of the effects of PAVE PAWS radiation on electronic devices used for medical monitoring or health evaluation, because there is evidence that such devices may be sensitive to such exposure.

In conclusion, the PAVE PAWS radar may be anticipated to expose a limited number of members of the general public intermittently to low intensities of pulse-modulated microwave fields with maximal instantaneous intensities of $100 \mu\text{W}/\text{cm}^2$ or less and time-averaged intensities lower by two orders of magnitude. There are no known irreversible effects of such exposure on either morbidity or mortality in humans or other species. Thus, it is improbable that exposure will present any hazard to the public. In view of the known sensitivity of the mammalian CNS to electromagnetic fields, especially those modulated at brainwave frequencies, the possibility cannot be ruled out that exposure to PAVE PAWS radiation may have some effects on exposed people. Because these effects are still hypothetical, it is not feasible to assess their health implications. Such assessment will require additional research and surveillance and must be addressed in future evaluations of the potential exposure effects of PAVE PAWS and other high-power-output radar systems.

GLOSSARY*

CONTINUOUS WAVE (CW): Refers to an unmodulated electromagnetic wave. When a wave is abruptly turned "on" and "off," the resulting burst is referred to as a pulsed wave.

ELECTRIC FIELD: An electric field is said to exist in a region if charged objects in the region experience a force. It is described in terms of the voltage gradient that exists over a given distance, volts per meter.

ELECTROMAGNETIC RADIATION: Radiation by which energy is propagated by interrelated electric and magnetic fields. Electromagnetic radiation travels at the speed of light in free space.

ENERGY DOSE: The quantity of electromagnetic energy in joules that is absorbed per unit of mass of a biological body. The unit of mass is kilogram (2.2 lb) and the dose is stated as joules per kilogram (J/kg). For convenience in working with small animals or with small samples of tissue, many researchers prefer to use joules or millijoules per gram (J/g or mJ/g) as working units. Dose is synonymous with "Specific Absorption" (SA), q.v.

[ENERGY] DOSE RATE: The time rate at which electromagnetic energy is imparted per unit of mass to a biological body, i.e., watts per kilogram (W/kg) or watts or milliwatts per gram (W/g or mW/g). Synonymous with "Specific Absorption Rate" (SAR), q.v.

FAR AND NEAR FIELDS: The E and H fields of an electromagnetic wave that is propagating in a uniform medium are always at right angles to each other and to the line of propagation in the "far field"; however, waves near an emitting source are complex in the sense that relative magnitudes and orientations of E and H fields can each vary greatly. Beyond the near field, i.e., in the far field, the relative maximum strengths of E and H fields do not change (although the total strength diminishes as distance from a point source increases).

FREE FIELD: A free (or open) field is generally considered to be an electromagnetic wave that is propagating in a vacuum or in air without interacting bodies.

*Reprinted from A Technical Review of the Biological Effects of Non-Ionizing Radiation, with the addition of definitions of "peak power density" and "time-averaged power density."

GIGA: Prefix denoting billion(s) in the U.S.A., i.e., 10^9 .

HERTZ (Hz): The cyclic rate at which a wave of energy changes; equivalent to frequency in cycles per second.

HOTSPOT: Electromagnetic waves are seldom, if ever, absorbed uniformly by a biological body. Concentrations of energy will occur that are called electrical hotspots. If the field is sufficiently intense to overcome local cooling by flow of blood in affected tissues, thermal hotspots may also occur.

JOULE: Under the International System, the basic unit of all forms of energy. As a thermal unit, one joule equals 0.239 calories. Since the calorie is defined as the energy required to heat one gram of water from 4 to 5°C, 4.184 joules is the equivalent of one calorie.

KILO: Prefix denoting thousand(s), i.e., 10^3 .

MAGNETIC FIELD: Exists in a region if magnetic objects in the region experience a force. An electrical current passing through a wire creates a magnetic field. The intensity of a magnetic field is measured in teslas. (1 tesla = 10,000 gauss)

MEGA: Prefix denoting million(s), i.e., 10^6 .

MICRO: Prefix denoting millionth (microwatt is one millionth of a watt).

MILLI: Prefix denoting thousandth (milliwatt is one thousand of a watt).

MODULATION: When a continuous series of waves of electromagnetic energy is modified by pulsing, or by varying its amplitude, frequency, or phase, the waves are said, respectively, to be pulse-, amplitude-, frequency-, or phase-modulated. In order to convey information by radiating electromagnetic energy, it must be modulated.

MULTIPATH RADIATION: In contrast with a so-called plane wave, which moves in a straight line through space, an area or volume where electromagnetic waves arrive from different directions because of reflection or multiple sources is said to be the site of multipath radiation. The cavity of a microwave oven exemplifies the multipath case.

PEAK POWER DENSITY: The maximal value of the rate of energy transmission of a time-varying electromagnetic field.

PLANE WAVE: The wave emanating from a point source is an expanding sphere. A segment of the wave at a great distance (with respect to wavelength) from the source may have little curvature relative to the dimensions of a small target and can therefore be treated as a moving plane.

POINT SOURCE: A source of radiation that is small in size with respect to its distance from a radiated target. The "inverse-square law" holds for a point-source radiation, i.e., the intensity of the field decreases rapidly--as a function of the square of the distance from the source.

POLARIZATION: The E and H fields that comprise a propagating electromagnetic wave may be fixed or they may rotate. If the E vector is perpendicular to the ground, the wave is said to be vertically polarized; if parallel, horizontally polarized. When the E and H fields are continuously rotating with respect to the direction of propagation the wave is said to be circularly polarized.

POWER: The time rate at which energy is generated, transferred, or dissipated. The unit of power, the watt (W), is defined as one joule per second (J/s).

POWER DENSITY: The time rate per unit of area at which electromagnetic energy flows through some medium. The quantity of energy is complexly related to the strengths of the E and the H fields. Power density is specified in watts per square meter (W/m^2), but it is often expressed in milliwatts per square centimeter (mW/cm^2). In common usage, power density is taken to mean the time rate at which electromagnetic energy is incident on a body per unit of surface area.

RESONANCE [ELECTRICAL]: A conductor or absorbing body of a given length in the free field will react maximally to an electromagnetic wave that is about twice the body's length. The maximal reaction is technically known as "resonance."

SCATTER: When an electromagnetic wave is incident on a body, the energy it carries will be absorbed and scattered. "Scatter" refers collectively to reflection, refraction, and diffraction of unabsorbed energy.

SPECIFIC ABSORPTION (SA): The quantity of electromagnetic energy in joules that is absorbed per unit of mass of an absorbing body is specified in joules per kilogram (J/kg); but often expressed as millijoules or joules per gram (mJ/g or J/g). Synonymous with (energy) dose q.v.

SPECIFIC ABSORPTION RATE (SAR): The time rate at which electromagnetic energy is absorbed per unit of mass of an absorbing body is specified in watts per kilogram (W/kg); but is often expressed as milliwatts or watts per gram (mW/g or W/g).

TIME-AVERAGED POWER DENSITY: The integral of the product of the instantaneous power density of pulsed electromagnetic radiation and the pulse duration taken over a characteristic sampling interval and divided by the duration of the sampling interval.

REFERENCES

1. Adey, W. R. Models of membranes of cerebral cells as substrates for information storage. *BioSystems* 8:163-178, 1977.
2. Adey, W. R., and S. M. Bawin, Eds. Brain interactions with weak electric and magnetic fields. Neurosci. Res. Program Bull. 15:1-129, 1977.
3. Albert, E. N. Light and electron microscopic observations on the blood-brain barrier after microwave irradiation, pp. 294-304. In D. G. Hazzard, Ed. *Symposium on Biological Effects and Measurement of Radio Frequency/Microwaves. Proceedings of a Conference held in Rockville, Md., Feb. 16-18, 1977.* U. S. Department of Health, Education, and Welfare, Public Health Service, Food and Drug Administration, Bureau of Radiological Health, DHEW Publ. No. (FDA) 77-8026. Washington, D.C.: U. S. Government Printing Office, 1977.
4. Appleton, B. Results of Clinical Surveys for Microwave Clinical Ocular Effects. U. S. DHEW Publ. No. (FDA) 73-8031. Rockville, Md.: U. S. Department of Health, Education, and Welfare, Bureau of Radiological Health, 1973.
5. Appleton, B., S. Hirsch, R. O. Kinion, M. Soles, G. C. McCrossan, and R. M. Neidlinger. Microwave lens effects in humans. II. Results of five-year survey. *Arch. Ophthalmol.* 93:257-258, 1975.
6. Appleton, B., and G. C. McCrossan. Microwave lens effects in humans. *Arch. Ophthalmol.* 88:259-262, 1972.
7. A Technical Review of the Biological Effects of Non-Ionizing Radiation: A report prepared for the Office of Science and Technology Policy by an ad hoc Working Group. May 15, 1978.
8. Athey, T. W., R. A. Tell, N. N. Hankin, D. L. Lambdin, E. D. Mantiply, and D. E. Janes. Radio-frequency Radiation Levels and Population Exposure in Urban Areas of the Eastern United States. Tech. Rep. EPA-520/2-77-008. Silver Spring, Md.: U. S. Environmental Protection Agency, 1978.
9. Aurell, E., and B. Tengroth. Lenticular and retinal changes secondary to microwave exposure. *Acta Ophthalmol.* 51:764-771, 1973.

10. Balzano, Q., O. Garay, and R. F. Steel. Energy deposition in biological tissue near portable radio transmitters at VHF and UHF, pp. 25-39. In Record of the Twenty-seventh Annual Conference. Orlando, Fla.: IEEE Vehicular Technology Group, 1977.
11. Baráński, S. Effect of chronic microwave irradiation on the blood forming system of guinea pigs and rabbits. Aerospace Med. 42:1196-1199, 1971.
12. Baráński, S., and P. Czerski. Biological Effects of Microwaves. Stroudsburg, Pennsylvania: Dowden, Hutchinson & Ross, Inc., 1976. 234pp.
13. Baráński, S., and Z. Edelwejn. Experimental morphologic and Electroencephalographic studies of microwave effects on the nervous system. Ann. N.Y. Acad. Sci. 247:109-116, 1975.
14. Baráński, S., and Z. Edelwejn. Pharmacologic analysis of microwave effects on the central nervous system in experimental animals, pp. 119-127. In: P. Czerski, Ed. Biologic Effects and Health Hazards of Microwave Radiation. Warsaw: Polish Medical Publishers, 1974.
15. Barber, P. W., O. P. Gandhi, M. J. Hagmann, and I. Chatterjee. Electromagnetic Absorption in a Multilayered Model of Man. IEEE Trans. Biomed. Eng. (In press)
16. Bawin, S. M. Electromagnetic Radiations and Biological Systems. USPHS Grant 1 R01, FD-678-01. Annual Report. Washington, D.C.: U. S. Department of Health, Education, and Welfare, Public Health Service, May 1975.
17. Bawin, S. M., and W. R. Adey. Sensitivity of calcium binding in cerebral tissue to weak environmental electric fields oscillating at low frequency. Proc. Nat. Acad. Sci., USA: 73:1999-2003, 1976.
18. Bawin, S. M., R. J. Gavalas-Medici, and W. R. Adey. Effects of modulated very high frequency fields on specific brain rhythms in cats. Brain Res. 58:365-384, 1973.
19. Bawin, S. M., L. K. Kaczmarek, and W. R. Adey. Effects of modulated VHF fields on the central nervous system. Ann. N.Y. Acad. Sci., 247:74-81, 1975.
20. Bawin, S. M., A. R. Sheppard, and W. R. Adey. Models of long-range order in cerebral macromolecules: Effects of ELF, VHF and UHF fields in calcium binding, P. 100. In Abstracts of Scientific Papers. 1977 International Symposium on the Biological Effects

of Electromagnetic Waves. Sponsored by the International Union of Radio Science and the U.S. National Committee for URSI. With the cooperation of the International Radiation Protection Association. Airlie, Va.: Oct. 30-Nov. 4, 1977.

21. Bawin, S. M., A. Sheppard, and W. R. Adey. Possible mechanisms of weak electromagnetic field coupling in brain tissue. *Bioelectrochem. and Bioenerget.* 5:67-76, 1978.
22. Bielski, J., J. Pianowska, A. Sawińska, and W. Gruszka. Nervous system changes in workers of radio-television stations exposed to microwaves. *Pol. Tyg. Lek.* 31:1369-1372, 1972.
23. Blackman, C. S., J. A. Elder, S. G. Bennane, C. M. Weil, and D. C. Eichinger. Two factors affecting the radiation-induced calcium efflux from brain tissue. In *Abstracts of Scientific Papers. 1977 International Symposium on the Biological Effects of Electromagnetic Waves.* Sponsored by the International Union of Radio Science and the U.S. National Committee for URSI. With the cooperation of the International Radiation Protection Association. Airlie, Va.: Oct. 30-Nov. 4, 1977.
24. Bronaugh, E. L., D. R. Kerns, and W. M. McGinnis. *Electromagnetic Emissions from Typical Citizens' Band Mobile Radio Installations in Three Sizes of Vehicles.* Proceedings of the Institute of Electrical and Electronic Engineers. Symposium on Electromagnetic Compatibility. Report No. 77CH1231-0 EMC. New York, N.Y.: IEEE, 1977.
25. Carpenter, R. L., E. S. Ferri, and G. L. Hogan. Assessing microwaves as a hazard to the eye: Progress and problems, pp. 178-185. In *Proceedings of International Symposium on Biologic Effects and Health Hazards of Microwave Radiation.* Warsaw: Polish Medical Publishers, 1974.
26. Carroll, D., D. M. Levinson, R. L. Clarke, and D. R. Justesen. Failure of Rats to Escape from an Intense 918-MHz Microwave Field, p. 35. *Abstracts of Scientific Papers. IMPI/URSI 1978 Symposium on Electromagnetic Fields in Biological Systems,* Ottawa: International Microwave Power Institute, 1978.
27. Chou, C-K., and A. W. Guy. Characteristics of microwave-induced cochlear microphonics. *Radio Sci.* 12(6S):221-227, 1977.
28. Cleary, S. F. Biological effects of microwave and radiofrequency radiation. *C.R.C. Crit. Rev. Environ. Control* 7:121-166, 1977.
29. Cleary, S. F., Survey of microwave and radiofrequency biological effects and mechanisms, pp. 1-33. In L. S. Taylor and A. Y. Cheung, Eds. *The Physical Basis of Electromagnetic Interactions*

with Biological Systems. Proceedings of a Workshop held at the University of Maryland, College Park, Md., June 15-17, 1977.

30. Cleary, S. F., and B. S. Pasternack. Lenticular changes in microwave workers. A statistical study. *Arch. Environ. Health* 12: 23-29, 1966.
31. Cleary, S. F., and R. T. Wangemann. Effect of microwave radiation on pentobarbital-induced sleeping time, pp. 311-322. In C. C. Johnson and M. L. Shore, Eds. *Biological Effects of Electromagnetic Waves. Selected Papers of the USNC/URSI Annual Meeting, Boulder, Colorado, Oct. 20-23, 1975. Vol. I.* Sponsored by the U. S. National Committee of the International Union of Radio Science. U. S. Department of Health, Education, and Welfare, Food and Drug Administration, Bureau of Radiological Health, Rockville, Md. DHEW Publ. (FDA) 77-8010. Washington, D.C.: U. S. Government Printing Office, 1976.
32. Cogan, D. G., S. J. Frecker, M. Lubin, D. D. Donaldson, and H. Hardy. Cataracts and ultra-high frequency radiation. *Arch. Ind. Health* 18:299-302, 1955.
33. Cohen, B. H., A. M. Lilienfeld, S. Kramer, and L. C. Hyman. Parental factors in Down's syndrome--results of the second Baltimore case-control study, pp. 301-352. In E. B. Hook and I. H. Porter, Eds. *Population Cytogenetics: Studies in Humans.* New York: Academic Press, Inc., 1977.
34. Cordiner, J. W., M. J. Carty, and D. Mackay. Infarction of fallopian tube after tubal diathermy. (Letter) *Lancet* 1:1178, 1976.
35. Czernski, P., E. Paprocka-Slonka, M. Siekierzynski, and A. Stolarska. Influence of microwave radiation on the hematopoietic system, pp. 67-74. In P. Czernski, Ed. *Biologic Effects and Health Hazards of Microwave Radiation.* Warsaw: Polish Medical Publishers, 1974.
36. Czernski, P., E. Paprocka-Slonka, and A. Stolarska. Microwave irradiation and the circadian rhythm of bone marrow cell mitosis. *J. Microwave Power* 9:31-37, 1974.
37. Czernski, P., and M. Siekierzynski. Analysis of occupational exposure to microwave radiation, pp. 367-377. In S. M. Michaelson, M. W. Miller, R. Magin, and E. L. Carstensen, Eds. *Fundamental and Applied Aspects of Nonionizing Radiation.* New York: Plenum Press, 1974.

38. Czerski, P., M. Siekierzynski, and A. Gidynski. Health surveillance of personnel occupationally exposed to microwaves. I. Theoretical considerations and practical aspects. *Aerospace Med.* 45:1137-1142, 1974.
39. Deichmann, W. B., J. Miale, and K. Landeen. Effect of microwave radiation on the hematopoietic system of the rat. *Toxicol. Appl. Pharmacol.* 6:71-77, 1964.
40. Dutta, S. K., W. H. Nelson, C. F. Blackman, and D. J. Brusick. Effects of chronic non-thermal exposures of pulsed microwaves on a repair-deficient mutant of Escherichia Coli. *Mutat. Res.* 53:91-92, 1978.
41. Edelman, G. M. Surface modulation in cell recognition and cell growth. *Science*, 192:218-226, 1976.
42. Edelwejn, Z., R. L. Elder, E. Klimková-Deutschová, and B. Tengroth. Occupational exposure and public health aspects of microwave radiation, pp. 330-331. In P. Czerski, Ed. *Biologic Effects and Health Hazards of Microwave Radiation*. Proceedings of an International Symposium, Warsaw: Polish Medical Publishers, 1974.
43. Ely, T. S. Microwave death. *JAMA* 217:1394, 1971.
44. Ewing, D. R., and J. A. Payne. Computer Access to Geographic Distribution of the Population. Memorandum 73-146. Washington, D.C.: Executive Office of the President, Office of Telecommunications Technical Policy, 1973.
45. Foster, K. R., and E. D. Finch. Microwave hearing: Evidence for thermoacoustic auditory stimulation by pulsed microwaves. *Science* 185:256-258, 1974.
46. Frey, A. H. Auditory system response to radio frequency energy. Technical Note. *Aerospace Med.* 32:1140-1142, 1961.
47. Frey, A. H. Behavioral biophysics, *Psychol. Bull.* 63:322-337, 1965.
48. Frey, A. H., and S. R. Feld. Avoidance by rats of illumination with low power nonionizing electromagnetic energy. *J. Comp. Physiol. Psychol.* 89:183-188, 1975.
49. Fröhlich, H. Long-range coherence and energy storage in biological systems. *Int. J. Quantum Chem.* 11:641-649, 1968.
50. Fröhlich, H. Possibilities of long- and short-range electric interactions of biological systems. *Neurosci. Res. Program Bull.* 15:67-72, 1977.

51. Gabovich, R. D., and O. M. Zhukovsky. On the procedures for studying the action of electromagnetic waves of radio-band frequency on the human organism in industry. *Gig. Tr. Prof. Zabol.* 10:26-29, 1976.
52. Gandhi, O. P. Conditions of strongest electromagnetic power deposition in man and animals. *IEEE Trans. Microwave Theory and Techniques.* MTT-23:1021-1029, 1975.
53. Gandhi, O. P. Polarization and frequency effects on whole animal absorption of RF energy. *Proc. IEEE* 62:1166-1168, 1974.
54. Gandhi, O. P., J. A. D'Andrea, B. K. Jenkins, J. L. Lords, J. R. Mijanovich, and K. Sedigh. Behavioral and Biological Effects of Resonant Electromagnetic Absorption in Rats. Tech. Report UTEC MD-75-174. Microwave Device and Physical Electronics Laboratory. Salt Lake City: University of Utah, June 1975.
55. Gandhi, O. P., and M. J. Haggmann. Some recent results on deposition of electromagnetic energy in animals and models of man, p. 51. In *Abstracts of Scientific Papers. 1977 International Symposium on the Biological Effects of Electromagnetic Waves.* Sponsored by the International Union of Radio Science and the U.S. National Committee for URSI. With the cooperation of the International Radiation Protection Association. Airlie, Va.: Oct. 30-Nov. 4, 1977.
56. Gandhi, O. P., and M. J. Haggmann. Some recent results on the deposition of electromagnetic energy in animals and models of man, pp. 243-259. In L. S. Taylor and A. Y. Cheung, Eds. *The Physical Basis of Electromagnetic Interactions with Biological Systems. Proceedings of a Workshop held at the University of Maryland, College Park, Md., June 15-17, 1977.*
57. Gandhi, O. P., E. L. Hunt, and J. A. D'Andrea. Deposition of electromagnetic energy in animals and in models of man with and without grounding and reflector effects. *Radio Sci.* 12(6S):39-47, 1977.
58. Gandhi, O. P., K. Sedigh, G. S. Beck, and E. L. Hunt. Distribution of electromagnetic energy deposition in models of man with frequencies near resonance, pp. 44-67. In C. C. Johnson and M. L. Shore, Eds. *Biological Effects of Electromagnetic Waves. Selected Papers of the USNC/URSI Annual Meeting, Boulder, Colorado, Oct. 20-23, 1975, Vol. 2.* Sponsored by the U.S. National Committee of the International Union of Radio Science. U. S. Department of Health, Education, and Welfare, Food and Drug Administration, Bureau of Radiological Health, Rockville, Md. DHEW Publ. (FDA) 77-8010. Washington, D.C.: U. S. Government Printing Office, 1976.

59. Gavalas, R. J., D. O. Walter, J. Hamer, and W. R. Adey. Effect of low-level, low-frequency electric fields on EEG and behavior in Macaca nemestrina. *Brain Res.* 18:491-501, 1970.
50. Glaser, Z. R., and C. H. Dodge. Biomedical aspects of radio frequency and microwave radiation: A review of selected Soviet, East European, and Western references, pp. 2-34. In C. C. Johnson and M. L. Shore, Eds. *Biological Effects of Electromagnetic Waves. Selected Papers of the USNC/URSI Annual Meeting, Boulder, Colorado, Oct. 20-23, 1975. Vol. I.* Sponsored by the U. S. National Committee of the International Union of Radio Science. U. S. Department of Health, Education, and Welfare, Food and Drug Administration, Bureau of Radiological Health, Rockville, Md. DHEW Publ. (FDA) 77-8010. Washington, D.C.: U.S. Government Printing Office, 1976.
61. Goldstein, L., and Z. Sisko. A quantitative electroencephalographic study of the acute effects of X-band microwaves in rabbits, pp. 128-133. In *Biologic Effects and Health Hazards of Microwave Radiation.* Warsaw: Polish Medical Publishers, 1974.
62. Gordon, Z. *Biological Effects of Microwaves in Occupational Hygiene.* Izdatelstro Medicina, Leningrad, 1966. (NASA TT F633, 1970)
63. Gordon, Z. V., A. V. Roščin, and M. S. Byčkov. Main directions and results of research conducted in the USSR on the biologic effects of microwaves, pp. 22-35. In P. Czerski, Ed. *Biologic Effects and Health Hazards of Microwave Radiation.* Warsaw: Polish Medical Publishers, 1974.
64. Grodsky, I. T. Neuronal membrane: A physical synthesis. *Math. Biosci.* 28:191-219, 1976.
65. Guskova, A. K., and E. M. Kochanova. Some aspects of etiological diagnosis in occupational diseases due to the action microwave radiation. *Gig. Tr. Prof. Zabol.* 3:14-18, 1976.
66. Guy, A. W. *Electromagnetic Interactions with Biological Materials.* AGARD Lecture Series No. 78. Radiation Hazards. Brussels Belg: NATO, Advisory Group for Aerospace Research and Development, 1975.
67. Guy, A. W., and C-K. Chou. Studies on the effects of high energy microwave pulsed exposure on the brain of the rat, p. 73. In *Symposium on Biological Effects of Electromagnetic Waves. 19th General Assembly of URSI, Helsinki, Finland, 1-8 Aug., 1978.*
68. Guy, A. W., C. K. Chou, J. C. Lin, and D. Christensen. Microwave-induced acoustic effects in mammalian auditory systems and physical materials. *Ann. N.Y. Acad. Sci.* 247:194-215, 1975.

69. Guy, A. W., C. K. Chou, J. C. Lin, and D. Christensen. Microwave Induced Acoustic Effects in Mammalian Auditory Systems and Physical Materials. AGARD Lecture Series No. 78. Radiation Hazards. Brussels, Belg: NATO, Advisory Group for Aerospace Research and Development, 1975.
70. Guy, A. W., J. C. Lin, P. O. Kramer, and A. F. Emery. Effect of 2450-MHz radiation on the rabbit eye. IEEE Trans. on Microwave Theory and Tech. MTT-23:492-498, 1975.
71. Guyton, A. C. Textbook of Medical Physiology, pp. 978-983. Philadelphia: W. B. Saunders Co., 1968.
72. Haggmann, M. J., O. P. Gandhi, J. A. D'Andrea, and I. Chatterjee. Head Resonance: Numerical Solutions and Experimental Results, p. 64. Abstracts of Scientific Papers. IMPR/URSI 1978 Symposium on Electromagnetic Fields in Biological Systems, June 27-30, 1978, Ottawa, Canada. Ottawa: International Microwave Power Institute, 1978.
73. Haggmann, M. J., O. P. Gandhi, and C. H. Durney. Numerical calculation of electromagnetic energy deposition in a realistic model of man, p. 56. In Abstracts of Scientific Papers. 1977 International Symposium on the Biological Effects of Electromagnetic Waves. Sponsored by the International Union of Radio Science and the U. S. National Committee for URSI. With the cooperation of the International Radiation Protection Association. Airlie, Va., Oct. 30-Nov. 4, 1977.
74. Hankin, N. N. An Evaluation of Selected Satellite Communication Systems as Sources of Environmental Microwave Radiation. Tech. Rep. EPA-520/2-74-008. Washington, D.C.: U. S. Environmental Protection Agency, 1974. (NTIS order No. PB 257 138/8BA)
75. Hankin, N. N. Environmental Impact Analysis, Project PAVE PAWS--Otis AFB, Massachusetts. Silver Spring, Md.: U. S. Environmental Protection Agency, Office of Radiation Programs, Electromagnetic Radiation Analysis Branch, December 22, 1977. 29 pp.
76. Hankin, N. N. Radiation Characteristics of Traffic Radar Systems. Tech. Note ORP/EAD-76-1. Silver Spring, Md.: U. S. Environmental Protection Agency, 1976. (NTIS Order No. PB 257 077)
77. Hirsch, F. G., and J. T. Parker. Bilateral lenticular opacities occurring in a technician operating a microwave generator. Arch. Ind. Hyg. Occup. Med. 6:512-517, 1952.
78. Hopfield, J. J. Relation between structure, co-operativity and spectra in a model of hemoglobin action. J. Molec. Biol. 77:207-222, 1973.

79. Janes, D. E., R. A. Tell, T. W. Athey, and N. N. Hankin. Nonionizing radiation exposure in urban areas of the United States, pp. 329-332. In G. Bresson, Ed. Proceedings of the 4th International Congress of the International Radiation Protection Association. Vol. 2., 1977.
80. Janes, D. E., R. A. Tell, T. W. Athey, and N. N. Hankin. Radio-frequency radiation levels in urban areas. Radio Sci. 12(6S): 49-56, 1977.
81. Jasik, H. Fundamentals of antennas, pp. 2-1-2-53. In H. Jasik, Ed. Antenna Engineering Handbook. New York: McGraw Hill Book Co., 1961.
82. Johnson, C. C., C. H. Durney, P. W. Barber, H. Massoudi, S. J. Allen, and J. C. Mitchell. Radiofrequency Radiation Dosimetry Handbook. Report SAM-TR-76-35. Brooks Air Force Base, Texas: USAF School of Aerospace Medicine, Sept. 1956.
83. Joines, W. T., and R. J. Spiegel. Resonance Absorption of Microwaves by the Human Skull. IEEE Trans. Biomed. Eng. BME-21:46-48, 1974.
84. Justesen, D. R., and N. W. King. Behavior-effects of low-level microwave irradiation in the closed space situation, pp. 154-179. In S. F. Cleary, Ed. Biological Effects and Health Implications of Microwave Radiation—Symposium Proceedings. (U. S. Public Health Service Publ. No. BRH/DBE 70-2) Washington, D.C.: U. S. Government Printing Office, 1970.
85. Justesen, D. R., R. A. Morantz, M. Clark, D. Reeves, and M. Mathews. Effects of handling and surgical treatment on convulsive latencies and mortality of tumor-bearing rats to 2450-MHz microwave radiation, p. 40. In Abstracts of Scientific Papers. 1977 International Symposium on the Biological Effects of Electromagnetic Waves. Sponsored by the International Union of Radio Science and the U.S. National Committee for URSI. With the cooperation of the International Radiation Protection Association. Airlie, Va., Oct. 30-Nov. 4, 1977.
86. Justesen, D. R., H. A. Ragan, L. E. Rogers, A. W. Guy, D. L. Hjeresen, and W. T. Hinds. Compilation and Assessment of Microwave Bioeffects A0-02-01/EA 81028. A Selective Review of the Literature on Biological Effects of Microwaves in Relation to the Satellite Power System. PNL-2634, UCrl. Richland, Washington: Batelle Memorial Institute, Pacific Northwest Laboratory, 1978.

87. Justesen, D. R., H. A. Ragan, L. E. Rogers, A. W. Guy, D. L. Hjeresen, W. T. Hinds, and R. D. Phillips. A Selective Review of the Literature on Biological Effects of Microwaves in Relation to the Satellite Power System. Washington, D.C.: U.S. Department of Energy, 1977. 65 pp.
88. Kaczmarek, L. K. Cation binding models for the interaction of membranes with EM fields. *Neurosci. Res. Program Bull.* 15:54-60, 1977.
89. King, N. W., D. R. Justesen, and R. L. Clarke. Behavioral sensitivity to microwave irradiation. *Science* 172:398-401, 1971.
90. Kritikos, H. N., and H. P. Schwan, 1975. The distribution of heating potential inside lossy pheres. *Engineers. IEEE Trans. Biomed. Eng.* 22:457-463, 1975.
91. Kurz, G. H., and R. B. Einaugler. Cataract secondary to microwave radiation. *Amer. J. Ophthalmol.* 66:866-869, 1968.
92. Lambdin, D. L. An Investigation of Energy Densities in the Vicinity of Vehicles with Mobile Communications Equipment and Near a Hand-Held Walkie Talkie. EPA Pub. ORP/EAD 79-2. Las Vegas, NV: U.S. Environmental Protection Agency, 1979.
93. Lancranjan, I., M. Măicănescu, E. Rafailă, I. Klepsch, and H. I. Popescu. Gonadic function in workmen with long-term exposure to microwaves. *Health Phys.* 29:381-383, 1975.
94. Larsen, E. B., and J. F. Shafer. Surveys of Electromagnetic Field Intensities Near Representative Higher-Power FAA Transmitting Antennas. Report No. FAA-RD-77-179. Washington, D.C.: U.S. Department of Transportation, 1977.
95. Lebovitz, R. M., and R. L. Seaman. Microwave hearing: The response of single auditory neurons in the cat to pulsed microwave radiation. *Radio Sci.* 12(6S):229-236, 1977.
96. Lilienfeld, A. M., J. Tonascia, S. Tonascia, C. Libauer, G. Cauthen, J. Markowitz, and S. Weida. Foreign Service Health Status Study. Evaluation of Health Status of Foreign Service and Other Employees from Selected European Posts. Baltimore, Md.: Johns Hopkins University, School of Hygiene and Public Health, Department of Epidemiology, 1978.
97. Lin, J. C. Microwave auditory effect - A comparison of some possible transduction mechanisms. *J. Microwave Power* 11:77-81, 1976.

98. Lin, J. C., A. W. Guy, and L. R. Caldwell. Thermographic and behavioral studies of rats in the near field of 918-MHz radiations. *IEEE Trans. Microwave Theory & Techniques*. MTT-25:833-836, 1977.
99. Lotz, W. G. Stimulation of the Adrenal Axis in the Microwave Exposed Rat. Ph.D. Thesis. Rochester, NY: University of Rochester, 1976.
100. Lovely, R. H., A. W. Guy, R. B. Johnson, and M. Mathews. Alteration of behavioral and biochemical parameters during and consequent to 500 $\mu\text{W}/\text{cm}^2$ chronic 2450-MHz microwave exposure, p. 34. Abstracts of Scientific Papers. IMPI/URSI 1978 Symposium on Electromagnetic Fields in Biological Systems, June 27-30, 1978, Ottawa, Canada. Ottawa: International Microwave Power Institute, 1978.
101. Lu, S-T., N. Lebda, S. M. Michaelson, S. Pettit, and D. Rivera. Thermal and endocrinological effects of protracted irradiation of rats by 2450-MHz microwaves, *Radio Sci.* 12(6S):147-156, 1977.
102. Luczak, M., S. Szmigielski, M. Janiak, M. Kobus, and E. de Clerq. Effect of microwaves on virus multiplication in mammalian cells in vivo and in vitro. *J. Microwave Power* 11:173-174, 1976.
103. Magin, R., S. Lu, and S. M. Michaelson. Thyroid Response to Localized Microwave Exposure, p. 317. (abstract) Technical Program Booklet. USNC/URSI Annual Meeting, Oct. 20-23, 1975, Boulder, Colorado. Washington, D.C.: National Academy of Sciences, 1975.
104. Mc Afee, R. D., R. Braus, Jr., and J. Fleming, Jr. The effect of 2450 MHz microwave irradiation on the growth of mice. *J. Microwave Power* 8:111-116, 1973.
105. McLaughlin, J. T. Health hazards from microwave radiation. *Western Med.* 3:126-132, 1962.
106. McLaughlin, J. T. Tissue destruction and death from microwave radiation (radar). *Calif. Med.* 86:336-339, 1957.
107. Merritt, J. H., R. H. Hartzell, and J. W. Frazer. The effect of 1.6 GHz radiation on neurotransmitters in discrete areas of the rat brain, pp. 290-298. In C. C. Johnson and M. L. Shore, Eds. *Biological Effects of Electromagnetic Waves. Selected Papers of the USNC/URSI Annual Meeting, Boulder, Colorado, Oct. 20-23, 1975, Vol. I.* Sponsored by the U.S. National Committee of the International Union of Radio Science. U.S. Department of Health, Education, and Welfare, Food and Drug Administration, Bureau of Radiological Health, Rockville, Md. DHEW Publ. (FDA) 77-8010. Washington, D.C.: U.S. Government Printing Office, 1976.
108. Merritt, J. H., M. A. Medina, and J. W. Frazer. Neurotransmitter content of mouse brain after inactivation by microwave heating. *Res. Commun. Chem. Pathol. Pharmacol.* 10:751-754, 1975.

109. Michaelson, S. M., W. M. Houk, N. J. A. Lebeda, S-T. Lu, and R. L. Magin. Biochemical and neuroendocrine aspects of exposure to microwaves. *Ann. N. Y. Acad. Sci.* 247:21-44, 1975.
110. Mielczarek, H. The neurological syndrome of the so-called microwave illness. *Lek. Wojsk.* 47:442, 1971.
111. Miro, L., R. Loubrière, and A. Pfister. Effects of microwaves on the cell metabolism of the reticulo-histiocytic system, pp. 89-97. In P. Czerski, Ed. *Biologic Effects and Health Hazards of Microwave Radiation*. Warsaw: Polish Medical Publishers, 1974.
112. Mitchell, J. C. *Electromagnetic Interference of Cardiac Pacemakers*. AGARD Lecture Series No. 78. *Radiation Hazards*. Brussels, Belgium: NATO, Advisory Group for Aerospace Research and Development, 1975.
113. Moe, K. E., R. H. Lovely, D. E. Myers, and A. W. Guy. Physiological and behavioral effects of chronic low level microwave radiation in rats, pp. 248-256. In C. C. Johnson, and M. L. Shore, Eds. *Biological Effects of Electromagnetic Waves*. Selected Papers of the USNC/URSI Annual Meeting, Boulder, Colorado, October 20-23, 1975. Vol. I. Sponsored by the U.S. National Committee of the International Union of Radio Science. U. S. Department of Health, Education, and Welfare, Food and Drug Administration, Bureau of Radiological Health, Rockville, Md. DHEW Publ. (FDA) 77-8010. Washington, D.C.: U. S. Government Printing Office, 1976.
114. Monahan, J. C., and H. S. Ho. The effect of ambient temperature on the reduction of microwave energy absorption by mice. *Radio Sci.* 12(6S):257-262, 1977.
115. Mueller, G. P., H. T. Chen, J. A. Dibbet, H. J. Chen, and J. Meites. Effects of warm and cold temperatures on release of TSH, GH, and prolactin in rats. *Proc. Soc. Exp. Biol. Med.* 147: 698-700, 1974.
116. National Research Council, Assembly of Engineering, Engineering Panel on the PAVE PAWS Radar System. *Radiation Intensity of the PAVE PAWS Radar System*. Washington, D.C.: National Academy of Sciences, 1979. 41 pp.
117. Neumann, E., and A. Katchalsky. Long-lived conformation changes induced by electric impulses in biopolymers. *Proc. Nat. Acad. Sci. USA* 69:993-997, 1972.

118. Olsen, R. G. Insect teratogenesis in a standing-wave irradiation system. *Radio Sci.* 12(6S):199-207, 1977.
119. Oscar, K. J. Determinants of brain uptake, p. 167. In *Abstracts of Scientific Papers. 1977 International Symposium on the Biological Effects of Electromagnetic Waves.* Sponsored by the International Union of Radio Science and the U. S. National Committee for URSI. With the cooperation of the International Radiation Protection Association. Airlie, Va., Oct. 30-Nov. 4, 1977.
120. PAVE PAWS System Program Office, Electronic Systems Division, Hanscom AFB. Power Density Measurements Report, PAVE PAWS. A report for Headquarters Air Force Systems Command, Andrews AFB, Washington, D. C. June 14, 1978. 24pp.
121. PAVE PAWS System Program Office, Electronic Systems Division, Hanscom AFB. Power Density Measurements Report Number 2, PAVE PAWS. A report for Headquarters Air Force Systems Command, Andrews AFB, Washington, D. C., September 22, 1978. 39pp.
122. PAVE PAWS System Program Office, Electronic Systems Division, Hanscom AFB. Power Density Measurements Report Number 3 (Preliminary). A report for Headquarters Air Force Systems Command, Andrews AFB, Washington, D. C., November 20, 1978. 44 pp.
123. Peak, D. W., D. L. Conover, W. A. Herman, and R. E. Shuping. Measurement of Power Density from Marine Radar. DHEW Publ. No. (FDA) 76-8004. Rockville, Md.: U. S. Department of Health, Education, and Welfare, Bureau of Radiological Health, 1975.
124. Petrov., I. R., Ed.: Influence of microwave radiation in the organism of man and animals. Medicina, Leningrad, 1972. (NTIS Order No. NASA TT-F-708).
125. Phillips, R. D., E. L. Hunt, and N. W. King. Field measurements, absorbed dose, and biologic dosimetry of microwaves. *Ann. N. Y. Acad. Sci.* 247:499-509, 1975.
126. Puska, P. The North Karelia Project: An attempt at community prevention of cardiovascular disease. *WHO Chron.* 27:55-58, 1973.
127. Rapoport, S. I. *The Blood-Brain Barrier in Physiology and Medicine.* N. Y.: Raven Press, Inc. 1976. 316 pp.
128. Reed, J. R., 3rd., J. L. Lord, and C. H. Durney. Microwave irradiation of the isolated rat heart after treatment with ANS blocking agents. *Radio Sci.* 12(6S):161-165, 1977.

129. Robinette, C. D., and C. Silverman. Causes of death following occupational exposures to microwave radiation (Radar) 1959-1974, pp. 338-344. In D. G. Hazzard, Ed. Symposium on Biological Effects and Measurement of Radio Frequency/Microwaves. Proceedings of a Conference held in Rockville, Md., Feb. 16-18, 1977. U. S. Department of Health, Education, and Welfare, Public Health Service, Food and Drug Administration, Bureau of Radiological Health. DHEW Publ. (FDA) 77-8026. Washington, D. C.: U. S. Government Printing Office, 1977.
130. Ruggera, P. S. Changes in Radiofrequency E-Field Strengths within a Hospital During a 16-Month Period. DHEW Publ. No. (FDA) 75-8032. Rockville, Md.: U. S. Department of Health, Education, and Welfare, Bureau of Radiological Health, 1975.
131. Ruggera, P. S. Near-field measurements of RF fields, pp. 104-116. In D. G. Hazzard, Ed. Symposium on Biological Effects and Measurement of Radio Frequency/Microwaves. Proceedings of a Conference held in Rockville, Md., Feb. 16-18, 1977. U. S. Department of Health, Education, and Welfare, Public Health Service, Food and Drug Administration, Bureau of Radiological Health. DHEW Publ. (FDA) 77-8026. Washington, D. C.: U. S. Government Printing Office, 1977.
132. Seaman, R. L. Effects of microwave radiation on Aplysian ganglion cells. Neurosci. Res. Program Bull. 15:45-48, 1977.
133. Selye, H. The general adaptation syndrome and the diseases of adaptation, J. Clin. Endocrinol. 6:117-230, 1946.
134. Servantie, B., A. M. Servantie, and J. Etienne. Synchronization of cortical neurons by a pulsed microwave field as evidenced by spectral analysis of electrocorticograms from the white rat. Ann. N. Y. Acad. Sci. 247:82-86, 1975.
135. Shacklett, D. E., T. J. Tredici, and D. L. Epstein. Evaluation of possible microwave-induced lens changes in the United States Air Force. Aviat., Space, Environ. Med. 46:1403-1406, 1975.
136. Shandala, M. G., M. I. Rudnev, G. K. Vinogradon, N. G. Belonozhko, and N. M. Gonchar. Immunological and hematological effects of microwaves at low power densities, p. 85. In Abstracts of Scientific Papers. 1977 International Symposium on the Biological Effects of Electromagnetic Waves. Sponsored by the International Union of Radio Science and the U. S. National Committee for URSI. With the cooperation of the International Radiation Protection Association. Airlie, Va.: Oct. 30 - Nov. 4, 1977.

137. Shirkovich, I. S., and V. G. Shilyaev. Cataracts of both eyes which developed as a result of repeated short exposure to an electromagnetic field of high density. *Vestn. Oftalmol.* 72:12-16, 1959.
138. Siekierzynski, M., P. Czerski, A. Gidynski, S. Zydecki, C. Czarnecki, E. Dziuk, and W. Jedrzejczak. Health surveillance of personnel occupationally exposed to microwaves. III. Lens translucency. *Aerospace Med.* 45:1146-1148, 1974.
139. Siekierzynski, M., P. Czerski, H. Milczarek, A. Gidynski, C. Czarnecki, E. Dziuk, and W. Jedrzejczak. Health surveillance of personnel occupationally exposed to microwaves. II. Functional disturbances. *Aerospace Med.* 45:1143-1145, 1974.
140. Smith, A. A., Jr. Attenuation of electric and magnetic fields by buildings. *IEEE Trans. Electromagnetic Compatibility EMC-20:* 411-418, 1978.
141. Snyder, S. H. The effect of microwave irradiation on the turnover rate of serotonin and norepinephrine and the effect of monoamine metabolizing enzymes. AD No. 729-161. Baltimore, Md.: Johns Hopkins University School of Medicine, 1971. 19 pp.
142. Štverak, I., K. Marha, and G. Pafkova. Some effects of various pulsed fields on animals with audiogenic epilepsy, pp. 141-144. In P. Czerski, Ed. *Biologic Effects and Health Hazards of Microwave Radiation.* Warsaw: Polish Medical Publishers, 1974.
143. Szmigielski, S., M. Luczak, M. Bielec, M. Janiak, M. Kobus, W. E. Stewart, and E. de Clerq. Effect of microwaves combined with interferon and/or interferon inducers (Poly I - Poly C) on development of sarcoma 180 in mice. *J. Microwave Power* 11:174-175, 1976.
144. Szmigielski, S., M. Luczak, M. Janiak, M. Kobus, and B. Laskowska. Effect of 3 GHz microwaves on experimental viral infections in mice (*Herpes vaccinia*), p. 117. In *Programs and Abstracts, 1976 Annual Meeting of U.S. National Committee/International Union of Radio Science.* Sponsored by USNC/URSI in cooperation with the Institute of Electrical and Electronics Engineers, Society on Antennas and Propagation, University of Massachusetts, Amherst, Mass., Oct. 11-15, 1976.
145. Takashima, S., B. Onaral, and H. P. Schwan. Effects of RF energy on the EEG of rabbit, p. 9. *Abstracts of Scientific Papers. IMPI/URSI 1978 Symposium on Electromagnetic Fields in Biological Systems, June 27-30, 1978, Ottawa, Canada.* Ottawa: International Microwave Power Institute, 1978.

146. Tell, R. A. An Analysis of Radar Exposure in the San Francisco Area. Tech. Note ORP/EAD-7703. Las Vegas, Nevada: U. S. Environmental Protection Agency, 1977. (NTIS Order No. PB 273 188)
147. Tell, R. A. An Analysis of Radiofrequency and Microwave Absorption Data with Consideration of Thermal Safety Standards. Tech. Note ORP/EAD 78-2. Las Vegas, Nevada: U. S. Environmental Protection Agency, 1978. (NTIS Order No. PB 284 639/2BE)
148. Tell, R. A. Environmental nonionizing radiation exposure: A preliminary analysis of the problem and continuing work within the Environmental Protection Agency, pp. 48-68. In Proceedings of the Session on Environmental Exposure to Nonionizing Radiation, 1972 American Public Health Association Meeting. Tech. Rep. EPA/ORP 73-2. Washington, D.C.: U.S. Environmental Protection Agency, 1973. (NTIS Order No. PB 220 851)
149. Tell, R. A. Near-Field Radiation Properties of Simple Linear Antennas with Applications to Radiofrequency Hazards and Broadcasting. Tech. Note ORP/EAD 78-4. Las Vegas, Nevada: U.S. Environmental Protection Agency, 1978.
150. Tell, R. A., and N. N. Hankin. Measurements of Radiofrequency Field Intensity in Buildings with Close Proximity to Broadcast Station. Tech. Note ORP/EAD 78-3. Las Vegas, Nevada: U.S. Environmental Protection Agency, 1978.
151. Tell, R. A., N. N. Hankin, and D. E. Janes. Aircraft radar measurements in the near field, pp. 239-246. In P. L. Carson, W. R. Hendee, and D. C. Hunt. Operational Health Physics. Proceedings of the Ninth Midyear Topical Symposium of the Health Physics Society. Boulder, Colorado: Central Rocky Mountain Chapter, Health Physics Society, 1976.
152. Tell, R. A., and E. D. Mantiply. Population Exposure to VHF and UHF Broadcast Radiation in the United States. Tech. Note ORP/EAD 78-5. Las Vegas, Nevada: U. S. Environmental Protection Agency, 1978. (NTIS Order No. PB 284 637/6BE)
153. Tell, R. A., and J. C. Nelson. Calculated field intensities near a high power UHF broadcast installation. Radiat. Data Rep. 15:401-410, 1974.
154. Tell, R. A., J. C. Nelson, and N. N. Hankin. HF spectral activity in the Washington, D.C. area. Radiat. Data Rep. 15:549-558, 1974.

155. Tell, R. A., and P. J. O'Brien. An Investigation of Broadcast Radiation Intensities at Mt. Wilson, California. Tech. Note ORP/EAD-77-2. Las Vegas, Nevada: U. S. Environmental Protection Agency, 1977. (NTIS Order No. PB 275 040/4BE)
156. Tuomilehto, J., A-L. Rajala, and P. Puska. A study on the drop-outs of the hypertension register of the North Karelia project. *Community Health* 7:149-152, 1976.
157. Wachtel, H., R. Seaman, and W. Joines. Effects of low-intensity microwaves on isolated neurons. *Ann. N. Y. Acad. Sci.* 247: 46-62, 1975.
158. Weil, C. M. Absorption characteristics of multilayered sphere models exposed to UHF/microwave radiation. *IEEE Trans. Biomed. Eng.* 22:468-476, 1975.
159. Wever, R. ELF-effects on human circadian rhythms, pp. 101-144. In M. A. Persinger, Ed. *ELF and VLF Electromagnetic Field Effects*. New York, N.Y.: Plenum Press, 1974.
160. White, R. M. Generation of elastic waves by transient surface heating. *J. Appl. Phys.* 34:3559-3567, 1963.
161. Wiktor-Jedrzejczak, W., A. Ahmed, P. Czernski, W. M. Leach, and K. W. Sell. Immune response of mice to 2450-MHz microwave radiation: Overview of immunology and empirical studies of lymphoid splenic cells. *Radio Sci.* 12(6S):209-219, 1977.
162. Wiktor-Jedrzejczak, W., A. Ahmed, K. W. Sell, P. Czernski, and W. M. Leach. Microwaves induce an increase in the frequency of complement receptor-bearing lymphoid spleen cells in mice. *J. Immunol.* 118:1499-1502, 1977.
163. Zaret, M. M. Clinical aspects of nonionizing radiation. *IEEE Trans. Biomed. Eng.* 19:313-316, 1972.
164. Zaret, M. M. Electronic smog as a potentiating factor in cardiovascular disease: A hypothesis of microwaves as an etiology for sudden death from heart attack in North Karelia. *Med. Res. Eng.* 12:13-16, 1976.
165. Zaret, M. M. Selected cases of microwave cataract in man associated with concomitant annotated pathologies, pp. 294-300. In *Biologic Effects and Health Hazards of Microwave Radiation. Proceedings of an International Symposium, Warsaw, Poland, Oct. 15-18, 1973*. Warsaw: Polish Medical Publishers, 1974.
166. Zaret, M. M., S. F. Cleary, B. S. Pasternack, and M. Eisenbud. Occurrence of Lenticular Imperfections in the Eyes of Microwave Workers and their Association with Environmental Factors. RADC-TN-61-226. New York, N.Y.: New York University, 1961.

167. Zaret, M. M., and W. Z. Snyder. Cataracts in aviation environments. Brit. J. Ophthalmol. 61:380-384, 1977.
168. Zydecki, S. Evaluation of Lens Transparency in Microwave Workers as Compared with Control Groups. Thesis. Warsaw: Instytut Kształcenia Polyplomowego W.A.M., 1972.
169. Zydecki, S. Examination and evaluation of the eye in individuals exposed to lens opacities. Lek. Wojsk. 43:124-129, 1967. (In Polish)
170. Zydecki, S. Preliminary results and evaluation of lens transparency in individuals exposed to microwaves. Klin. Oczna 38:31-33, 1968. (In Polish)