



## Evaluation of Methodologies for Estimating Vulnerability to Electromagnetic Pulse Effects: A Report (1984)

Pages  
112

Size  
8.5 x 11

ISBN  
0309323762

Committee on Electromagnetic Pulse Environment;  
Energy Engineering Board; Commission on Engineering  
and Technical Systems; National Research Council

 [Find Similar Titles](#)

 [More Information](#)

### Visit the National Academies Press online and register for...

✓ Instant access to free PDF downloads of titles from the

- NATIONAL ACADEMY OF SCIENCES
- NATIONAL ACADEMY OF ENGINEERING
- INSTITUTE OF MEDICINE
- NATIONAL RESEARCH COUNCIL

✓ 10% off print titles

✓ Custom notification of new releases in your field of interest

✓ Special offers and discounts

Distribution, posting, or copying of this PDF is strictly prohibited without written permission of the National Academies Press. Unless otherwise indicated, all materials in this PDF are copyrighted by the National Academy of Sciences.

To request permission to reprint or otherwise distribute portions of this publication contact our Customer Service Department at 800-624-6242.

Copyright © National Academy of Sciences. All rights reserved.

# **Evaluation of Methodologies for Estimating Vulnerability to Electromagnetic Pulse Effects**

*A Report Prepared by the*  
**Committee on Electromagnetic Pulse Environment  
Energy Engineering Board  
Commission on Engineering and Technical Systems  
National Research Council**

**NATIONAL ACADEMY PRESS**  
Washington, D.C. 1984

NAS-NAE  
AUG 8 1984  
LIBRARY

**NOTICE:** The project that is the subject of this report was approved by the Governing Board of the National Research Council, whose members are drawn from the councils of the National Academy of Sciences, the National Academy of Engineering, and the Institute of Medicine. The members of the committee responsible for the report were chosen for their special competences and with regard for appropriate balance.

This report has been reviewed by a group other than the authors according to procedures approved by a Report Review Committee consisting of members of the National Academy of Sciences, the National Academy of Engineering, and the Institute of Medicine.

The National Research Council was established by the National Academy of Sciences in 1916 to associate the broad community of science and technology with the Academy's purposes of furthering knowledge and of advising the federal government. The Council operates in accordance with general policies determined by the Academy under the authority of its congressional charter of 1863, which establishes the Academy as a private, nonprofit, self-governing membership corporation. The Council has become the principal operating agency of both the National Academy of Sciences and the National Academy of Engineering in the conduct of their services to the government, the public, and the scientific and engineering communities. It is administered jointly by both Academies and the Institute of Medicine. The National Academy of Engineering and the Institute of Medicine were established in 1964 and 1970, respectively, under the charter of the National Academy of Sciences.

This is a report of work supported by Contract No. DNA001-82-C-0309 between the Defense Nuclear Agency and the National Academy of Sciences.

**Copies available from:**

Energy Engineering Board  
Commission on Engineering and Technical Systems  
National Research Council  
2101 Constitution Avenue, N.W.  
Washington, D.C. 20418

Printed in the United States of America

COMMITTEE ON ELECTROMAGNETIC PULSE ENVIRONMENT

JOHN R. PIERCE (Chairman), Emeritus Professor of Engineering,  
California Institute of Technology, Pasadena, California

HERMAN CHERNOFF, Professor of Applied Mathematics, Massachusetts  
Institute of Technology, Cambridge, Massachusetts

WILLIAM E. CORY, Vice President, Electronic Systems Division, Southwest  
Research Institute, San Antonio, Texas

DONALD P. GAVER, Professor of Operations Research, Naval Postgraduate  
School, Monterey, California

WALTER J. KARPLUS, Professor of Computer Science, University of  
California, Los Angeles, California

NANCY R. MANN, Research Professor, University of California Medical  
School, Los Angeles, California

STEWART D. PERSONICK, Division Manager, Transwitching Technology  
Research, Bell Communications Research, Incorporated, Holmdel,  
New Jersey

ALLEN M. PETERSON, Professor of Electrical Engineering, Stanford  
University, Stanford, California

HENRY O. POLLAK, Assistant Vice President, Mathematical,  
Communications, and Computer Sciences Research Laboratory, Bell  
Communications Research, Incorporated, Murray Hill, New Jersey

NOZER D. SINGPURWALLA, Professor of Operations Research and Professor  
of Statistics, George Washington University, Washington, D.C.

**Staff:**

DENNIS F. MILLER, Acting Executive Director, Energy Engineering Board

JOHN M. RICHARDSON, Principal Staff Officer, Committee on  
Electromagnetic Pulse Environment

SIDNEY G. REED, JR., Consultant

HELEN D. JOHNSON, Administrative Associate

CHERYL A. WOODWARD, Administrative Assistant

ENERGY ENGINEERING BOARD

HERBERT H. WOODSON (Chairman), Ernest H. Cockrell Centennial  
Professor of Engineering, The University of Texas at Austin,  
Austin, Texas

ALLEN J. BARD, Norman Hackerman Professor of Chemistry, The  
University of Texas at Austin, Austin, Texas

ROBERT J. BUDNITZ, President, Future Resources Associates,  
Incorporated, Berkeley, California

NICHOLAS J. GRANT, Professor of Materials Science and Engineering,  
Massachusetts Institute of Technology, Cambridge, Massachusetts

BRUCE H. HANNON, Department of Geography, University of Illinois at  
Urbana-Champaign, Urbana, Illinois

GARY H. HEICHEL, Plant Physiologist and Professor of Agronomy,  
University of Minnesota, St. Paul, Minnesota

EDWARD A. MASON, Vice President, Research, Standard Oil Company  
(Indiana), Amoco Research Center, Naperville, Illinois

ALAN D. PASTERNAK, Energy Consultant, Sacramento, California

DAVID J. ROSE, Professor of Nuclear Engineering, Massachusetts  
Institute of Technology, Cambridge, Massachusetts

ADEL F. SAROFIM, Professor of Chemical Engineering, Massachusetts  
Institute of Technology, Cambridge, Massachusetts

MELVIN K. SIMMONS, Corporate Research & Development, General Electric  
Company, Schenectady, New York

WESTON M. STACEY, JR., Callaway Professor of Nuclear Engineering,  
Georgia Institute of Technology, Atlanta, Georgia

THOMAS E. STELSON, Vice President for Research, Georgia Institute of  
Technology, Atlanta, Georgia

JAMES L. SWEENEY, Professor of Engineering-Economic Systems,  
Chairman, Institute for Energy Studies, Stanford University,  
Stanford, California

GRANT P. THOMPSON, Senior Associate, The Conservation Foundation,  
Washington, D.C.

RICHARD WILSON, Mallinckrodt Professor of Physics and Chairman of the  
Department, Harvard University, Cambridge, Massachusetts

Technical Advisory Panel

HAROLD M. AGNEW, President, GA Technologies, Incorporated, San Diego,  
California

MICHEL T. HALBOUTY, Consulting Geologist and Petroleum Engineer,  
Houston, Texas

FRANKLIN A. LINDSAY, Chairman, Engenics, Incorporated, Lexington,  
Massachusetts

STANFORD S. PENNER, Director, Energy Center and Professor of  
Engineering Physics, University of California, San Diego, La Jolla,  
California

CHAUNCEY STARR, Vice Chairman, Electric Power Research Institute,  
Palo Alto, California

## PREFACE

This study is a review of current methods for estimating the vulnerability of systems within the Earth's atmosphere to the electromagnetic pulse (EMP) formed by nuclear explosions at high altitudes, above the atmosphere. The Defense Nuclear Agency, U. S. Department of Defense, requested the review from the National Research Council. The request stemmed from concern over reliability of estimates of the degree of protection offered by different engineering approaches and, in particular, over the use of statistics in making such estimates. The request did not embrace any other nuclear explosion effects. Accordingly, the study committee, formed by the Energy Engineering Board of the Commission on Engineering and Technical Systems, has left the relative significance of EMP to other analyses.

As a useful context for its work, the committee first obtained an overview of the high-altitude EMP problem and of the uncertainties involved, focusing on vulnerability assessment methodologies. The high-altitude EMP problem is impressively complicated, with many connected parts. Each part is complex in itself and requires substantial effort in computational codes: the mechanism of electromagnetic pulse generation, "coupling" of the pulse field with structures to induce currents and voltages within systems--not always linearly, susceptibilities of a subsystem to failure by damage to its components and by upset caused by internal currents and voltages, and methods of combining uncertainties to form probabilistic estimates of overall system survival during its mission in an electromagnetic pulse environment.

After this overview the committee received information from the Department of Defense and its contractors in areas directly relevant to its task. The committee also heard individuals from non-defense groups, such as American Telephone and Telegraph Company, the Energy Research Advisory Board of the U. S. Department of Energy, and the Nuclear Regulatory Commission, which are also concerned with the EMP vulnerability problem.

The committee had access to classified information but it did not receive complete results of actual weapons-system tests or

assessments. Nevertheless, I believe the committee obtained an appreciation of current methodologies of system vulnerability assessments adequate to reach firm conclusions about the state of the art of the statistics involved and to comment on the engineering approaches to protection against high altitude EMP. By focussing on methodologies, rather than results, the committee has been able to produce an unclassified report.

Taken as a whole, I believe the report addresses most of the sponsor's concerns, as posed in the form of questions intended to guide the committee's work. Rather than prescribe the manner of implementation of the recommendations, details are purposely left to the program managers of the EMP community.

Because EMP vulnerability assessment and protection are such specialized topics, the audience contemplated for the report is primarily the sponsor and those immediately concerned with technical aspects of the problem. Hence considerable background is assumed, and the report omits a comprehensive survey for the general reader of the many elements of the overall problem.

The committee is grateful to Gordon K. Soper, of the Defense Nuclear Agency, for his support, encouragement, and perspective on the task. Others in that agency, notably Col. William E. Adams, Bronius Cikotas, and Lt. Col. Robert B. Williams, supplied much information and made many arrangements for briefings, visits, and security. Our thanks also go to the individuals and organizations that provided the many briefings listed in Appendix B. Special thanks are due to John W. Tukey, of Princeton University, who, in the course of his review of the report manuscript, offered the section in Chapter 4 giving guidance on different kinds of statistics. Finally, I wish to acknowledge the assistance rendered by the staff of the Energy Engineering Board. Dennis F. Miller, Executive Director, was largely responsible for launching this project and for providing important assistance during its course. John M. Richardson served as study director. I appreciate as well the ready help of Sidney G. Reed Jr., Helen D. Johnson, and Cheryl A. Woodward, of the board and committee staffs.

John R. Pierce, Chairman  
Committee on Electromagnetic  
Pulse Environment



## CONTENTS

EXECUTIVE SUMMARY	1
Overview	1
Conclusions	2
Recommendations	4
1 INTRODUCTION	6
The Task	6
The Approach	7
2 THREAT AND HISTORY	9
Early Observations	9
The Generation of Electromagnetic Pulse	10
System Vulnerability	12
Other Electromagnetic Threats	13
3 PROTECTION AND ASSESSABILITY	15
Levels of Severity of Stress	15
The Protection Process for Other Stresses and for Electromagnetic Pulse	16
Testing and Verification Methodologies	18
Tailored Hardening	21
Shielding	22
Conclusions and Recommendations Concerning Protection	24
4 STATISTICAL TECHNIQUES IN ELECTROMAGNETIC PULSE WORK	26
Various Measures of Vulnerability	26
On the Current Use of Statistics in the Electromagnetic Pulse Community	28
Potential Role of Statistics	29
What Is Probability?	32
Some Applications of Probability	36
General Guidance on Different Kinds of "Statistics"	39
Conclusions and Recommendations Concerning Statistics	41

## EXECUTIVE SUMMARY

High-altitude electromagnetic pulse (EMP) is an electromagnetic radiation of very short rise time, large amplitude, and brief duration that follows a nuclear explosion above the atmosphere. The area over which a single EMP event is experienced can be very great if the explosion is high enough and large enough. Several such nuclear explosions might render unprotected electronic equipment and systems inoperative over an area as large as the continental United States. Damage may occur when high currents and voltages, driven by EMP, reach vital internal circuits. It is therefore essential to protect the systems and to form some idea of how well they will withstand EMP.

### OVERVIEW

The Committee on Electromagnetic Pulse Environment was formed in late 1982 to advise the Defense Nuclear Agency on estimating vulnerability to EMP. In the committee's charge there was a strong emphasis on the assessment of vulnerability to high-altitude EMP and on statistics as a method of assessment. Attention was also to be given to techniques of protection, testing, and engineering analysis as they bear on assessment of vulnerability.

Both the design and the assessment of protection against EMP are inherently subject to uncertainty. The reason is that these processes must be conducted without exposure to actual EMP, in contrast to the situation for other forms of electrical overstress.

Estimating vulnerability of systems to electromagnetic pulse effects depends greatly on the nature of the system. The soundest results can be obtained where stress within the system is controlled, through integral shielding and penetration-control devices, to well known values. In this case, one can rely on engineering analysis and systematic testing of a predominantly deterministic nature. Where control and knowledge of stress, as well as of strength, are not possible because of system design, complexity, or uncontrolled changes, probabilistic estimates become necessary. Statistical methods for estimating and combining uncertainties, fault tree

analysis, and Bayesian inference may be used to systematize the estimates of vulnerability. However, repeated testing of systems, and subsystems, at as high a simulated threat level as possible, is essential with this approach. Whatever method is used, the uncertainty of the result should be clearly emphasized to decision makers lest oversimplification result.

## CONCLUSIONS

One crucial conclusion cuts across the whole EMP protection program: adequate testing is the appropriate means for assessment. Adequate testing, in turn, rests on two foundations. The first is engineering design that produces units amenable to meaningful tests. The second is the use of statistics to collect, analyze, interpret, and present the test data, together with the associated uncertainties, with clarity.

### Engineering Aspects

On the engineering side, assessability should be an important design criterion. It is imperative to utilize a design strategy that is testable to a high degree of assurance and, preferably, that can be monitored for continued effectiveness during the actual operation of the equipment. Some designs are much more easily assessable than others.

For example, shielding is a fairly simple and sure approach to EMP protection. If the system is shielded so well that the internal fields produced by EMP are at the level of system noise, periodic tests of the integrity of the shielding and tests at high level by applying pulses individually to all leads entering the shielded enclosure can constitute an adequate test. Thus, assessment is made much more practical by integral shielding around a whole system (such as a system housed in a building on the ground). Alternatively, subsystems of the system may be put into very well shielded boxes; and, except for power, antenna, and a few other properly filtered leads, all (signal) interconnections may be made by the rapidly developing technology of fiber optics, which cannot conduct EMP into the boxes. Antennas, by their very nature, must be exposed to EMP; thus their lead-in transmission lines require specialized protective measures.

"Tailored hardening," the major alternative to shielding for EMP protection, carries with it more risk of vulnerability. In this approach selected subsystems and components are protected against high-level fields. In this case, to assess resistance, or "hardness," to EMP effects, the entire system (perhaps a whole aircraft) must be tested at threat level initially. The purpose of testing after shielding or hardening is just as much to detect unsuspected faults in the shielding or hardening process as it is to see whether the

analytic predictions are correct. The system may likewise require retesting after modification or replacement of parts. For systems with tailored hardening, difficulty in making accurate analytic predictions of their response to such high-level testing has served to limit credence in the estimation of response to an actual EMP event. For these reasons the committee is uncomfortable with the use of tailored hardening to design new systems. Nevertheless, the methods of tailored hardening can be useful for improving the protection of large, existing systems.

The committee emphasizes the difficulty of adequately assessing unhardened systems and systems with tailored hardening. Even given a positive assessment, in our present state of knowledge such systems may or may not be hard. One should distinguish demonstrated hardness from, as noted in Chapter 4, "semiquantitative statements or...a 'warm or cold feeling' about the hardness of the system."

In assessing hardness against EMP, it is necessary to assess the hardness of only those systems essential to the completion of the mission. Thus, it is important to identify the essential systems. Not only must these essential systems be hard, but also inter-connections among them must be hard.

We also observe that the final word has not been spoken on the nature of the threat and the optimum protection against it.

#### Statistical Aspects

On the statistics side, the findings of the statisticians, who worked as a panel, were crucial to the conclusions of the committee as a whole. With minor exceptions, the statisticians found deficiencies and evidence of lack of expertise and confusion of issues in the statistical work that was presented to them. Some of this confusion has found its way into contract performance specifications. Beyond what has been commonly employed so far, an appreciable number of available and emerging statistical techniques, including fault tree analysis, can be usefully applied to portions of the EMP problem. Advanced training and educational opportunities would help inject such expertise into the EMP field.

The potential role of statistics in EMP protection and assessment is not merely central, but is essential and inevitable at several levels of the EMP problem. Statistics can aid engineers in their efforts to design hardened and testable units. Statistics is well suited to characterize certain properties of large populations of piece parts and the quality control of shielding. Statistics can improve the design of tests and the evaluation of results at both the subsystem and system level. For huge systems that cannot be tested as a whole, there is little other recourse than statistical inference from incomplete information. Certain statistical methods provide a framework for compounding performance estimates for portions of the system into performance estimates for the whole system.

When a quite uncertain number is the best that can be had, it may be important to get it and important not to throw it away--but even more important not to take it too seriously.

And finally, since there is no way to base an analytical estimate of EMP vulnerability on first principles, there can be no substitute for the best physical simulations possible as a route to adjust and improve the results of analytical studies.

#### RECOMMENDATIONS

Our recommendations concerning the achievement, through engineering design, of assessable military systems protected against EMP follow from the conclusions outlined above. These recommendations are excerpted here for reference:

- o There should be a continued reappraisal of the threat, its consequences, and the best near-term practices and longer-term research needed for meeting it.
- o Adequate analyses should be made of what systems, subsystems, and support systems are essential to completion of mission.
- o There should be great emphasis on achieving assessability by promptly developing better and cheaper means for virtually complete and effective shielding of systems essential to the completion of mission. This objective should include a strong emphasis on early use of standardized shielded boxes interconnected with optical fibers.
- o There should be a program to study and devise and evaluate the best and most economical way for continual testing to assure the maintenance of hardness.
- o There should be a better understanding of the mechanisms of component failure and better and more insightful component tests and interpretation of test data.
- o There should be increased emphasis on thoroughgoing analysis, testing, and comparison of analysis with test at the level of functional circuit aggregations, or "boxes."
- o A long-range program should be initiated and directed toward the systematic validation of prediction methods. The TRESTLE and comparable high-level simulators constitute a promising avenue to that end. These simulators generate pulses that are similar in many ways to, but also significantly different from, the expected EMP event. Important insights into the credibility of prediction methods themselves could be obtained by employing these methods to predict the response of components and systems to the fields known to be produced by the simulators and by confirming those predictions with experiments using the simulators.

Our recommendations concerning statistics and statisticians also flow from the conclusions that are summarized above. These recommendations, likewise, are listed here for reference:

- o The EMP community, including its management, should be better educated on the key ideas and procedures of statistics and reliability. Improved standardization of statistical terminology used by the EMP community should be pursued in order to reduce confusion with respect to its interpretation and uses.
- o The government should utilize qualified and experienced personnel, well trained in statistics, to oversee contractors' bids and work that involve statistics.
- o Collaboration among statisticians, engineers, and physicists working in the field of EMP protection and assessment should be encouraged. The statisticians on such teams should be well versed in the latest techniques and developments in statistical methodologies and reliability.
- o Contractual specifications that may be interpreted to require survival with probability equal to one (that is, certainty) should be avoided. Such specifications can lead to misunderstanding and legal problems, as well as to a poor choice of contractors. We recommend, rather, a collection of tests such that passing all will be acceptable as satisfaction of EMP requirements.
- o Because fault tree analysis is a useful management tool, it should be utilized in EMP work where it is applicable. Both empirical and theoretical work may be required to tailor fault trees to the particular needs of the EMP problem.
- o The Defense Nuclear Agency should establish a number of postdoctoral fellowships closely integrated with the field of EMP protection and assessment. The fellowships could be administered so as to encourage interdisciplinary collaboration, attract new talent to the field, and supplement the ongoing programs.

INTRODUCTION

High-altitude electromagnetic pulse (EMP) is an electromagnetic radiation of very short rise time, large amplitude, and brief duration that follows a nuclear explosion above the atmosphere. The area over which a single EMP event is experienced can be very great if the explosion is high enough and large enough. Several such nuclear explosions might render unprotected electronic equipment and systems within the atmosphere inoperative over an area as large as the continental United States. Other electromagnetic disturbances, such as lightning, occur; but none constitute the extensive threat of EMP.

THE TASK

Accordingly, estimation of vulnerability to EMP effects is essential for strategic and tactical decisions affecting national security. Such estimates are usually made using a combination of methods most appropriate to the case at hand. Predictive calculations of EMP stresses are made. Breakdown thresholds of electronic components are measured. Preliminary system vulnerability estimates are put together. Protective measures are engineered. Small-scale tests and large-scale simulations may be conducted. The cycle of analysis, protection, and test may continue until responsible individuals are satisfied with the vulnerability estimate. The outstanding problems, however, are that data are sparse and great uncertainties attach to the entire process of estimation and protection. Thus one appeals to statistical methods to make the most of the data. Even more important is the characterization of the uncertainty in the resulting vulnerability estimate, since the usefulness of the estimate depends crucially on its validity.

The Committee on Electromagnetic Pulse Environment was formed in late 1982 to evaluate methodologies commonly used for estimating vulnerability to EMP effects for the Defense Nuclear Agency (DNA). At the first meeting of the committee on February 2, 1983, Dr. Gordon K. Soper, then Acting Deputy Director for Science and Technology of DNA, gave a far-ranging overview of EMP problems and issues. He also

presented six questions, given in Appendix A, as a guide to the committee's work. While these questions raised issues regarding the efficiency and assessability of various methods of protection, especially "tailored hardening" versus "integral shielding with protected penetration controls," there was a repeated emphasis on the usefulness and appropriateness of statistical measures such as "probability of survival" and "confidence."

The chief role of the committee, as distilled from its statement of task (Appendix A) and from Dr. Soper's briefing, was to give the sponsor sound advice on practical methods for assessing military systems and subsystems for effective operation after exposure to EMP, taking into account the analysis, testing, and protective techniques that may be employed.

#### THE APPROACH

The committee was constituted to deal expertly with matters of both a statistical and an engineering nature. Of the total committee membership of ten, five members were statisticians or mathematicians with a statistical background. One was a systems analyst with expertise in the statistical aspects of simulation. Four were electrical engineers. In the committee's work, the statisticians acted as a panel in dealing with essentially statistical problems.

The committee was given a large amount of information about various issues relevant to DNA's concern with EMP, such as testing procedures and protective measures. These matters are addressed in some detail later in this report. Other issues include the nature of the threat, countermeasures, and the question of who should oversee the validity of work and methods. There is also a substantial number of issues concerned with non-military systems and products on which the military depends, including the civilian communications and power networks and such common items as automobiles and hand calculators. The committee received briefings concerning these issues; and material from some of the briefings is reflected in this report, chiefly in Chapter 2, which provides a background for the committee's work. Much of what the committee heard provided a useful context for its chief task.

Presentations at committee meetings are listed in Appendix B. These topics included the overall high-altitude EMP problem, magnitude of the EMP effect, estimation of currents and voltages due to EMP, and the role of thresholds for failure. The topics also covered different engineering approaches to protection, examples of vulnerability assessment methodology, and suggested programs for improvement of probabilistic estimates, including the use of Bayesian approaches to uncertainty. Visits to several test facilities were made. Assessment methodology was the dominant topic. The committee heard, in all, five briefings on aircraft vulnerability assessment, one presentation on a major strategic missile, and two descriptions of ground command and



control stations. The statistics group held several sessions of their own. One, in New York, dealt with estimation of probability of survival and codes for calculating system responses to EMP. Another, in Albuquerque, covered efforts to obtain and analyze data on component failure.

The chapters that follow, and the related appendixes, reflect the structure of the EMP vulnerability assessment problem. Thus Chapter 2 outlines the physical mechanism of generation of high-altitude EMP. The chapter also gives a brief account of actual observations of EMP and its effects produced by the U.S. high-altitude nuclear tests in the early 1960s. Appreciation of the magnitude and other characteristics of high-altitude EMP occurred about the time when progress in electronics began to lead to widespread use of semiconductor components. Such components are generally more vulnerable than the components they replaced. Chapter 2, together with Appendix C, notes also that considerable uncertainty exists in estimates of voltages and currents within complex systems because of interaction of the electromagnetic pulse fields with these systems. Chapter 3, along with Appendix D, deals with the protection of systems whose vulnerability to high-altitude EMP is to be estimated. That chapter outlines what are believed to be sound engineering principles and practices. The chapter also discusses pros and cons of two approaches to protection that emphasize, respectively, shielding and selective, or "tailored," hardening. Chapter 4, mainly the contribution of the statistics panel, discusses the application of statistics to the estimation of vulnerability of systems to high-altitude EMP. (Appendixes E through G give further details.) Finally, Chapter 5 contains conclusions and recommendations.

## THREAT AND HISTORY

The threat presented by electromagnetic pulse (EMP) is an extraordinary one in at least four ways compared to other electromagnetic disturbances. EMP is of very large magnitude; it occurs over a large area; its onset is extremely fast; and it is of brief duration. These characteristics in combination create a serious problem of vulnerability for electronic systems. This chapter cites some early observations of EMP effects, qualitatively describes the generation of the EMP phenomena itself, comments upon the vulnerability of various kinds of systems, and briefly compares EMP to other electromagnetic threats.

### EARLY OBSERVATIONS

While some aspects of EMP were understood before the termination of all but underground tests in 1963, the large magnitude of the EMP from explosions above the atmosphere was not correctly predicted until afterwards. Strong EMP effects were first noticed in July of 1962, during the FISHBOWL sequence of high-altitude nuclear tests. STARFISH, a detonation over Johnson Atoll, 800 miles southwest of Hawaii, caused a minor disruption of street-light power on Oahu and set off numerous burglar alarms. Telephone service was not interrupted as a result of this detonation. However, this fact does not necessarily mean that the telephone network is immune to EMP threats that may occur under current or foreseeable conditions.

Three other tests later in 1962--CHECKMATE, BLUEGILL, and KINGFISH--were instrumented (though imperfectly, for lack of full understanding of the phenomenon) for studying the electromagnetic fields at ground level following detonation. Some data on the magnitude of the EMP were obtained during these tests. These data are consistent with the currently accepted theory, first described by Longmire (1964), and later elaborated by him and by others (Longmire, 1978; Karzas and Latter, 1965; Crain, 1982).

## THE GENERATION OF ELECTROMAGNETIC PULSE

## Main Features

The main features of EMP may be appreciated from a few qualitative considerations. The underlying cause of EMP is gamma radiation, created extremely rapidly by a nuclear explosion and lasting only briefly. The fast onset of EMP and its brief duration are related in part to these characteristics of the gamma radiation. The large terrestrial area over which EMP will occur results from the fact that a high-altitude burst will irradiate the Earth's atmosphere, within which the pulse is generated, out to a very distant horizon. The large magnitude of EMP at all points within the atmosphere within line of sight of the explosion and the related sharp onset of EMP occur for two reasons. First, the gamma radiation and the newly developing pulse are both traveling outward with the same speed--the speed of light. Thus later contributions to the pulse from the action of the gamma radiation coincide with, and add directly to, the pulse already formed. Secondly, electrons produced by the gamma radiation are the direct sources of the pulse mainly because of their spiral motion in the Earth's magnetic field; these electrons also travel outward with nearly the speed of light; thus the later contribution to the outward-traveling pulse from a given electron nearly coincides with, and adds to, its prior contributions, actually generating a more sharply rising pulse than would otherwise occur. The magnitude of EMP, even from very powerful nuclear devices, reaches a limit set by electrical conductivity in the atmosphere, also caused by the nuclear explosion.

## Greater Detail

For those interested in greater detail, the generation of EMP is described more fully in the following paragraphs.

A nuclear explosion in space produces an intense pulse of gamma rays with a rise time of the order of a few nanoseconds and a decay time of a few tens of nanoseconds. After emission from the nuclear explosion these prompt gammas travel in a spherical shell with thickness of a few meters and with radius that increases at the speed of light.

The downward-traveling part of this shell begins to interact appreciably with the atmosphere at altitudes of 40 kilometers (km) to 50 km. The gammas, in traveling through the air, produce a flux of Compton recoil electrons, which constitutes an electron current density with a rise time approximately similar to that of the gamma rays. At about 30 km altitude, the gammas have passed through a mass of air equivalent to one absorption length, the absorption length being approximately equal to an atmospheric scale height of about

7 km. At the altitude of about 30 km the generation of Compton recoil electrons is at a maximum, since for higher altitudes there is less air density with which to interact and at lower altitudes the gammas have been mostly absorbed.

The Compton electrons are deflected from their predominantly radial path from the burst by the Earth's magnetic field. (The radius of curvature of the deflected motion is on the order of meters.) As a result of the rotation of the electrons by the magnetic field, a component of the Compton current is generated transverse to the radial direction from the explosion. Although other components of current are present, it is the transverse current and the outgoing EM signal radiated by it that result in the large EM pulse that is observed in the radial direction from the explosion.

Since the gamma rays move outward from the burst at the speed of light, the Compton current pulse also appears to do so. This traveling-pulse feature of the Compton current has an important effect on both the amplitude and rise time of the EM pulse that is observed. EM signals generated at different distances from the explosion, and therefore at different times, tend to arrive simultaneously at a distant observer along the same ray path. The amplitude is thereby reinforced and the rise time is shortened.

Each of the Compton electrons originates with energy of about 1 million electron volts (MeV) and generates on the order of 30,000 secondary electron-ion pairs along its track in the air. These secondary electrons do not contribute to the electromagnetic (EM) field generation mechanism, but they do constitute a conducting region that serves to limit the peak value of the EM field generated by the high-energy (1-MeV) electrons.

The most used method (Longmire, 1978; Karzas and Latter, 1965) for calculating the radiated EM field results from combining the individual Compton electron motions to determine a time- and space-dependent current density, from which the radiation field is calculated as a solution of the Maxwell equations. An alternative solution (Crain, 1982) can be obtained by summing the radiation from the individual Compton electrons in a three-dimensional volume. When correctly carried out both methods give essentially the same results. Peak field strengths within a factor of two greater or less than 30 kilovolts per meter are obtained from the calculations. The pulse rise times are on the order of a few nanoseconds, resulting in important spectral components up to frequencies on the order of hundreds of megahertz.

During the initial short rise time portion of the EM signal, coherent radiation occurs from electrons in a region extending only a few hundred meters transverse to the line of sight from the observer to the explosion. Similar results can be obtained for the current-shell methods by the use of Fresnel-zone arguments. Thus from the point of view of a given observer only a rather small region of the total volume illuminated by the gamma rays will be crucial to the

short rise-time portion of the EM pulse signal. However, essentially the same phenomenon occurs for an observer anywhere within a large area; hence the widespread coverage of an EMP event.

To insure the survival of military systems the Defense Nuclear Agency has developed interim threat level "EM Pulse Criteria"--both for waveforms in time and for the resultant spectra. The interim criteria are aimed at including the entire package of EM pulse characteristics that it is believed might reasonably be encountered by military systems as a result of exposure to a range of weapons, from present day stockpile devices to somewhat EMP-enhanced designs. These "criteria" waveforms appear to provide reasonable guidance to system designers for system hardening purposes and test purposes. Some people, however, worry that they may somewhat overestimate the threat that would be encountered under most circumstances. The committee is aware of views developed by the Rand Corporation (Appendix B, presentation by Bedrosian, August 9-10, 1983) concerning these maximum threat models and the response of the Defense Nuclear Agency (1983). These views do not affect the conclusions of the committee on evaluation and protection methodologies.

In addition to EMP, high-altitude nuclear explosions generate a "magnetohydrodynamic" pulse of much longer duration, which develops more slowly. This effect somewhat resembles that due to severe solar storms, which sometimes cause damage in geographically extensive systems, such as coaxial cable communications systems and power systems. Vulnerability to magnetohydrodynamic effects is not treated in this report.

#### SYSTEM VULNERABILITY

System vulnerability to damage depends in a large part on the overall coupling of EMP, not only through deliberate paths into vital internal circuits (such as antennas, waveguides, power lines, and telephone lines) but also through unintentional paths (such as conductors other than signal and power lines, imperfect shields, and faulty ground connections). Appendix C presents a fuller discussion of coupling, the methods for quantitatively analyzing it, and the resulting uncertainties.

After the mechanism and magnitude of EMP were understood, a number of simulators for investigating system vulnerability were built by federal agencies and private firms, including American Telephone and Telegraph Company and Rockwell International Corporation. Various devices and systems have been subjected to simulated EMP, including automobiles, walkie-talkies, hand calculators (Appendix B, presentation by Cikotas, April 1-2, 1983), airplanes, telephone switching systems, and telephone offices (Appendix B, presentations by Grimmelmann and by Osifchin, April 1-2, 1983). Resistance to damage and dysfunction has varied widely among similar small devices such as hand calculators, according to Cikotas' presentation.

The vulnerability to EMP of civilian communications and power systems is difficult to assess; this vulnerability depends on the care and soundness of engineering design and protection against other large electrical disturbances, including lightning, and on the degree to which EMP is taken into account in designing and modifying such systems. For example, Osifchin's presentation stated that a carefully built Autovon switching node showed neither damage nor serious degradation of service during repeated simulated EMPs. Other, less rugged switching equipment has been damaged under similar conditions.

The National Security Telecommunication Advisory Committee, appointed in 1982 by the President Reagan, with staff support from the National Communications Systems, a unit of the Defense Communications Agency, is currently working toward measures for reducing the impact of EMP and other nuclear effects on common-carrier communications. One means being considered is that of reconstituting the network after attack by bypassing inoperative portions of the system with remaining links. While this is an excellent approach for dealing with localized damage from other nuclear effects, it may be less effective in dealing with the widespread damage that might be caused by EMP.

The approach of the Bell System has been somewhat different (Bell Telephone Laboratories, Inc., 1975; also Appendix B, presentation by Osifchin, April 1-2, 1983). This approach has been to minimize the effects of EMP by careful engineering practices, including shielding where needed, and to provide added protective devices for circuits and equipment used by the government.

We mention such widespread implications of EMP because they are of general concern and interest and because they have some assessment and protection methodologies in common. However, we concentrated on methods for assessing the degree of protection of various military systems and installations essential to an adequate response to an attack using EMP. Our examination necessarily included the means of protection of aircraft and missile systems and radar and other detection systems. We also paid attention to hardened emergency communications systems, for use if both common-carrier facilities and common-carrier services fail.

#### OTHER ELECTROMAGNETIC THREATS

Other than EMP, there are numerous electromagnetic threats, both man-made and natural, to military systems. Such threats include internal interference from other circuits, transient overvoltages and overcurrents on power and signal lines, radiating electric and magnetic fields from nearby equipment and systems, electrostatic discharge, and natural phenomena such as lightning. The differences in the interference sources can be described in terms of (1) the magnitude and spectral characteristics of the electric field, the magnetic field, and the conducted voltages and currents and (2) the

propagation characteristics of the wave fronts and polarization of the electric field and magnetic field. These threats may be compared briefly with EMP.

The uniqueness of EMP is, first, its rarity--we do not encounter EMP events apart from nuclear hostilities--and, second, its temporal and spectral form. EMP has a very short rise time, a short time duration, and a very high magnitude. No other man-made or natural source exactly matches these characteristics. Lightning can exceed EMP's electromagnetic magnitudes, but its spectral distribution of power is less than that of EMP above 20 megahertz (MHz) to 40 MHz. Also, the area covered by high electromagnetic field strength is small for lightning compared to that for EMP (Chapter 3).

In addition to lightning, numerous man-made sources, such as radar and "directed energy" weapons, have high peak-power, pulsed outputs. These sources do not generate a substantial low-frequency spectral distribution of power, as EMP does; but their high-frequency spectral power can exceed that of EMP at selected frequencies.

It is conceivable that a system supposedly hardened against EMP might fail when exposed to lightning or to one of the man-made high-intensity fields mentioned above. This breakdown might disclose some unsuspected weakness in the protection provided against EMP. Thus, any such failures should be carefully investigated. However, because of the unique temporal and spectral characteristics of EMP, we believe that failures due to lightning and the other hazards cited should at most be considered as a secondary means for assessing systems protected against EMP.

### PROTECTION AND ASSESSABILITY

The possibility of an adequate assessment of system hardness against the electromagnetic pulse (EMP) threat depends on the nature of the system as well as on the assessment method. An unprotected system of unknown configuration and performance requirements is essentially unassessable. Systems with known requirements hardened against EMP in various ways have various degrees of assessability. This chapter describes some of the protective approaches that must be assessed both by engineering test and by the statistical techniques discussed in Chapter 4. One section points out the importance of the design, prototype, and deployment phases in attaining protection against EMP and other stresses. Another section reviews the merits of various methods in common use for assessing, by test and verification, the degree of EMP protection actually attained. Finally, the chapter compares the degree of assurance offered by the two main protection approaches, known as tailored hardening and shielding.

#### LEVELS OF SEVERITY OF STRESS

The EMP fields couple to metallic elements of electronic and power systems and produce voltages and currents, which add stress to electronic components and interfere with normal voltages and currents representing information. We may consider three levels of severity, within the spectral range of EMP effects, at a given electronic component terminal:

1. The voltages and currents caused by EMP are small compared to the voltages and currents in the absence of EMP.
2. The voltages and currents caused by EMP are comparable to the voltages and currents in the absence of EMP, and the resultant levels can produce upsets (Appendix D).
3. The voltages and currents caused by EMP are large compared to the voltages and currents in the absence of EMP, and the resultant levels can produce upsets and damage.



Assessment is easiest and surest when systems are designed so that components experience only the first severity level. This design assures that effects of EMP, if any, will be limited to disturbance in a small number of electronic circuits with marginal performance even in the absence of EMP.

#### THE PROTECTION PROCESS FOR OTHER STRESSES AND FOR ELECTROMAGNETIC PULSE

Stresses, other than EMP, in the form of undesired voltages and currents appear in electronic circuits for various reasons, including the following: interference from other circuits, transient (momentary) overvoltages and overcurrents produced when equipment power is turned on or off, stresses caused by temporary improper operation by operators, electrostatic discharge, and stresses caused by lightning. (Lightning has some of the characteristics of EMP, as pointed out later in this chapter.)

#### Idealized Protection Process

Normal engineering design practices take into account the possibility of these typical stresses and attempt to produce designs that can survive and operate under such stresses with only occasional isolated problems. The design process begins with a specification embracing the type of environment that a piece of equipment must tolerate without damage and within which it must operate properly. Care is taken to combine experience and specific information about the application to produce a specification that is as close as possible to the real environment.

Using mathematical analysis and modeling tools, engineers design circuits that can be expected to meet the specifications. This design process includes the selection of components whose ruggedness is sufficient for the anticipated stresses. Since individual components of a given type are not identical when actually manufactured, the designer will select component types with enough safety margin to allow for manufacturing variability. In some critical cases, the designer may require that each component of a particular type be individually tested before being used in the equipment.

Having completed this initial design process, design engineers will arrange for the production of prototype versions of the equipment. Such prototype equipment will be tested in the laboratory under conditions that simulate the anticipated real environment (including, for example, simulated stresses due to lightning). However, since the prototype equipment contains only representative samples of components, one cannot be sure that the results of this testing apply to the vast majority of units that will ultimately be deployed. Also,

the simulated environment may not be totally representative of the extremes of the actual environment.

Any design deficiencies discovered in the testing of the prototypes are corrected, and a second round of prototype testing proceeds. This process is repeated until the design engineers have verified, through testing and simulation, that the equipment "meets the specifications."

The equipment is then manufactured and deployed. It is not unusual, particularly in complex equipment, to discover design defects after deployment. One expects some incidence of random failure of isolated pieces of equipment due to defects in components and to operating environments that are more severe than those anticipated in the design phase. However, some types of failures, which occur too frequently, will be traced to design errors. That is, components within the circuitry, although not defective, are being stressed beyond their tolerance. Design errors at this point must be corrected by a very costly process, including such measures as modification or recall of units deployed in the field, modification of units in manufacture or in inventory, and modification of documentation. This costly process is avoided as much as possible by careful initial design and testing before deployment; nevertheless, it typically occurs in complex products.

#### Protection Process for Electromagnetic Pulse

Comparing the above exemplary protection process to the protection process for EMP, one notes some important similarities and contrasts.

EMP is a producer of voltage and current stresses, just as are lightning and the other causes mentioned above. Under idealized assumptions one could predict the stresses produced by EMP and could design circuitry to accommodate those stresses. However, the stresses produced by actual EMP may not correspond to those predicted by analytical methods.\* As in conventional stresses, oversights and modeling errors could be uncovered either by testing or in the actual environment. For EMP, of course, the opportunity to learn from failures in the deployment phase comes too late. Since failures occurring in the actual environment might affect all systems simultaneously (inasmuch as EMP effects occur over a large geographical area simultaneously) it is imperative to utilize a design strategy that is testable to a high degree of assurance and, preferably, that can be monitored for continued effectiveness during the actual operation of the equipment.

---

\*In results reported to the committee for field simulators, predicted stresses differed from measured stresses, on both the high and the low side, by up to two orders of magnitude in power (Appendix B, presentation by Van Zandt on September 30-October 1, 1983).

## TESTING AND VERIFICATION METHODOLOGIES

International agreements prohibiting the testing of nuclear weapons in or above the atmosphere also preclude the observation of EMP and its effects on real systems. (An exception is some limited extrapolation from the 1962 FISHBOWL test series.) Thus it is important to review the types of tests that can be made to estimate and verify EMP protection, both in the design process and in the maintenance of hardened systems.

## Field Simulators

The effects of EMP are induced by the coupling of the electromagnetic field caused by a nuclear event to metallic structures--ultimately producing harmful currents and voltages at the terminals of electronic components. One approach for testing the vulnerability of systems to "real" EMP is to generate fields within a volume of space that have characteristics similar to the anticipated fields from a real event. Systems that can be entirely enclosed within that volume of space can then be tested. This approach is practical for small systems, which can be exposed to EMP simulation fields in a correspondingly small simulator. The fact that small simulators, which can produce local fields equaling or exceeding the anticipated actual EMP over a small volume of space, can be economically constructed gives advantage to any protection strategy that allows large systems to be tested as small individually hardened modules.

When designing an EMP simulator, care must be taken to account for the effects of reflections from ground planes (conducting surfaces), which disturb the field and which may not be present in actual system operation. Care must be taken to produce fields having temporal characteristics (turn-on and turn-off times) similar to actual EMP. The larger the volume of space to be illuminated with artificially generated fields, the more costly the simulator and the more difficult it becomes to simulate real EMP accurately. Additionally, large simulators, such as those at the Air Force Weapons Laboratory in Albuquerque, are so cumbersome to operate that only very limited test data can be acquired--typically on a sample size of only one complete system. These limitations, while unavoidable, need to be recognized in interpreting such test results.

An alternative to the generation of threat-level simulated EMP is to generate low-amplitude fields in an appropriate volume of space. If one assumes that the response of the system grows linearly in relation to the field level, then one can extrapolate observed currents and voltages to threat-level. However, this approach has two significant shortcomings. First, the low-level responses (currents and voltages) do not cause failures or upsets. Measured values of these responses (at a limited number of test points) must be

extrapolated to infer failures or upsets at threat level, based on estimated vulnerabilities of subsystems exposed to those extrapolated voltages and currents. Second, the assumption of a linear system response is not necessarily valid and is difficult to verify without threat-level exposure.

#### Direct Current and Voltage Drive

As stated, EMP fields may produce damaging currents and voltages at the terminals of susceptible equipment. If one assumes that most of these effects are the results of currents and voltages induced on conductors leading to the terminal interfaces of electronic modules, then one can attempt to measure vulnerability by reproducing anticipated currents and voltages at these terminals with appropriate signal generators.

The advantage of this approach is that it is relatively easy to generate currents and voltages on conductors with directly attached signal generators, as compared to inducing these currents and voltages with field simulators. However, in modern systems, typical electronic modules have numerous powering and signal-carrying terminal interfaces. The currents and voltages presented at these interfaces can have differing amplitudes, polarities, and waveforms in time. Because of this fact, one would have to know the exact waveforms that would be produced by EMP on each terminal and would have to reproduce them all individually.

On the other hand, one can attempt to glean some insight regarding the EMP hardness of a module by driving all interfaces simultaneously with some voltage or current, estimated to be at threat level. However, it is not obvious that such a test actually simulates the true EMP stress. If, however, the number of interfaces to metallic conductors were reduced (using fiber optics for signal transportation) to a single power lead, this approach to EMP stress simulation would be more convincing.

#### Testing for Shielding Integrity

One approach to EMP protection, which is more fully discussed later in this chapter, is shielding. In this method, one attempts to prevent harmful fields from reaching susceptible components by enclosing the components in a metallic shield. Verification that the shield design is effective is best done with full threat-level field simulators (to uncover elusive nonlinear effects). However, once the basic design is verified, low-level field generators can be used to monitor the shield for deterioration (penetrations) over time. In essence, a low-level generator is placed on one side of the shield (inside or outside) and

appropriate signal detectors are placed on the other side. This process can be automated for continuous testing where appropriate.

#### Natural Lightning as a Simulator of EMP

It has been proposed that there are similarities between the stress imposed by natural lightning events on systems in operational use and the stress that they might encounter from an EMP event. Over a region of space lightning produces intense electromagnetic fields, which can couple to nearby metallic structures just as EMP couples to metallic structures.

A lightning flash typically lasts about one-half second and consists of a large number of diverse processes, each of which generates an electromagnetic signal (Oetzel and Pierce, 1969). Since the lightning channel is a line source (at least for the large ground-return stroke), as contrasted with the two-dimensional EMP source, the field strength decreases rapidly with increasing distance from the stroke. When one scales observed lightning field strengths to short distances (on the order of 50 meters) to obtain higher fields, the field strength of lightning is more severe than that of nuclear EMP below 1 MHz. However, since the rise time of EMP is only a few nanoseconds compared to a few microseconds for the relatively slower rise time of lightning, the EMP environment is more severe than that of lightning in the region above 1 MHz. Furthermore, the coupling of fields in the environment around a system like an aircraft to components within the system is strongly enhanced by the electrical resonances of the system. A typical aircraft fuselage resonates in the range of frequencies between 1 MHz and 10 MHz. Internal wiring resonances are typically above 20 MHz. Thus the relatively low-frequency lightning fields will couple relatively little energy into the internal components of an airplane, while the relatively high-frequency EMP fields will couple relatively large amounts of energy to internal components.

Compounding these significant differences between lightning and nuclear EMP are uncertainties regarding the true characteristics of lightning at close range. Scaling of lightning data observed at relatively long range to give estimates of field strengths at short range is not a straightforward process, particularly for the high-frequency part of the lightning spectrum. In addition to the ground-return strokes of some kilometers in length, lightning includes a large number (on the order of  $10^4$ ) of smaller events of some meters in length, which contribute much of the higher-frequency energy (Uman et al., 1978; Rustan, Uman, et al., 1980). Unless measurements are made with appropriately wide-band receivers, which distinguish short-duration individual events, extrapolation errors are likely to occur. Narrow-band receivers, for example, may integrate the power from many small events when measuring at a distance. In this case extrapolation of results to short ranges can become erroneous. At

short ranges only a few of the isolated events producing high-frequency waves will be near the target system. (See Cianos and Pierce, 1972).

Although lightning has a number of characteristics in common with EMP, the differences are so important that lightning does not appear to provide a satisfactory system test mechanism to ensure safety against nuclear EMP.

#### TAILORED HARDENING

The committee heard a number of presentations describing the "tailored-hardening" approach to EMP protection. This approach was applied both in the retroactive hardening of systems that were not specifically designed to survive the EMP environment and in the development of new systems.

In the tailored-hardening approach, the engineer responsible for EMP protection uses mathematical models of a system to estimate the voltages and currents that will appear at the electrical interfaces to electronic modules (circuit boards) in the system. The engineer attempts to estimate the susceptibility of these modules to EMP damage by examining circuit documentation available from the design and production phases. Cases are identified where the EMP stress predicted by the models exceeds the calculated susceptibility levels of the modules. Corrective action in the form of protection devices or module modifications is taken to eliminate these situations.

Although the committee recognized the value of modeling in understanding more clearly the nature and magnitude of the EMP problem, it is skeptical of the assurance one can have in the hardness of systems protected by these methods for the following reasons:

1. The methods of analysis used to predict susceptibility of electronic modules to the overvoltages and overcurrents induced by EMP appear likely to result in only very crude approximations of actual susceptibilities. This result is due not only to the approximations used to make the analyses tractable but also to the uncertainties in the susceptibilities of components within the modules.
2. The methods of analysis used to predict the overvoltages and overcurrents that might appear at the module interfaces are likely to produce estimates that are not representative of the real situation. This result may occur both because approximations are adopted to make the analyses tractable and because critical assumptions about the nature of the wiring within the system (which couples to EMP) may not necessarily be valid for actual systems under test. With typical configuration management of complicated systems, different individual units of the same nominal type differ in important

- details, such as wiring, wire routing, and particular components within the subsystems. (See Appendix C.)
3. Techniques used to add margin for error caused by point 1 and point 2, above, are built upon a long and tenuous string of assumptions and approximations.
  4. Most of the tailored-hardening analyses attempt to identify components that might be damaged by EMP. The problems associated with upset (for example, loss of stored information or unintentional initiation of undesirable actions) due to EMP are typically not addressed by this methodology.
  5. In systems that were protected by the tailored-hardening methods and then exposed to simulated EMP environments, measured currents on conductors deviated by large amounts from predicted values. Unpredicted "surprises" (failures and upsets) occurred. These results tended to increase the committee's reservations regarding the assurance one can ascribe to the hardening of systems protected in this manner.

In spite of the skepticism just expressed as to the protection attainable with tailored hardening, the committee still views the associated analysis as a useful methodology for dealing with the EMP susceptibility of existing systems not amenable to new design. The tailored-hardening analysis can identify opportunities to reduce EMP susceptibility further. We believe, however, that most of the benefits of tailored hardening come from good engineering practices verified by full threat-level tests and not from detailed analysis or statistical inference based on the variations mentioned above in the susceptibilities, predicted overvoltages, and measured currents.

The committee, moreover, is uncomfortable with the use of tailored hardening as a methodology to design new systems. The concern is both with the ability to protect systems by these methods and with the ability to retain protection as systems are modified or maintained. These concerns increase with the introduction of increasingly complex and vulnerable circuitry as a result of progress like very large scale integration (VLSI) and very high speed integrated circuits (VHSIC).

#### SHIELDING

The committee also heard presentations on the protection strategy called shielding. In this approach the system or subsystem designer is tasked, within constraints such as weight and cost, to prevent EMP effects from reaching susceptible components, rather than hardening the components themselves. No established standards for shielding exist as yet. However, the strategy is to accomplish the shielding, by means of metallic films, screens, or enclosures, to a sufficient degree that the residual fields, produced by EMP at the components

inside the shield, are small compared to the fields that are present in normal operation. Furthermore, measures must be implemented to prevent currents produced by EMP in nonshielded metallic conductors, such as antennas, from being carried into the shield interior by conductors, such as lead-in transmission lines, that penetrate the shield. By implication, if the components function properly in normal operation, the small incremental disturbances produced by EMP will disrupt only subsystems that are already functioning marginally. These effects will be identical to isolated random failure effects and will be protected against by normal system redundancy and gradually eliminated by normal system upgrading.

Shielding has a key advantage over tailored hardening in assessing system hardness. Specifically, one does not have to know the susceptibilities of components, such as transistors and integrated circuits, or subsystems, such as computers, within the shield because the EMP stress is reduced to levels below those to which they are exposed in normal operation.

Shielding should be able to provide protection against EMP effects with a very high degree of assurance if the following criteria are satisfied:

1. The shielding methodology must be simple and readily standardized in order that the effectiveness of the shielding can be readily understood and verified.
2. The shielding must be amenable to continuous or periodic in-service "proof testing" to verify retention of EMP protection.
3. The shielding methodology preferably should be modular, whereby individual subsystems can be protected--and certified to be so by testing--and whereby the interconnection of the protected subsystems into a system does not compromise the protection. This approach would make system protection independent of minor variations in system configuration, provided the modules (subsystems) comprising the system are all verified to be protected.

#### Shielding of Entire Systems

The committee heard several presentations that described examples of entire systems that had been shielded to protect against EMP. These examples included strategic missiles, aircraft, large communication complexes, and relatively small buildings that formed elements of a strategic command relay system. Shielding of buildings, where weight is not a factor, appears to be reasonably straightforward and appears to satisfy the first two criteria in the preceding section. This approach was described by Morgan (Appendix B, presentation on April 1-2, 1983), by Chodorow (Appendix B, presentation on September



30-October 1, 1983), and by Cikotas in his discussions of the Ground Wave Emergency Network (GWEN) system (Appendix B, presentation on April 1-2, 1983). We emphasize that continuing, in-service proof testing is vital because any large, long-term installation is subject to modification by workers who may not be aware of how hardness is achieved and preserved and who may destroy the shielding inadvertently.

Shielding of missiles and aircraft is more complex because of the constraints on the shielding design imposed by airworthiness and aircraft configuration. Testing and redesign of the shielding through several iterations have been required to produce satisfactory test results. In the case of missiles and aircraft, it does not appear that either criterion 1 or criterion 2 in the preceding section is satisfied. On the other hand, the committee feels that total shielding of aircraft and missiles, making use of the aircraft skin and of films or screens over apertures, is useful when carefully implemented.

#### Shielding of Subsystems Interconnected by Fiber Optics

One possible shielding approach is to house relatively small subsystems in standardized shielded enclosures and to interconnect the subsystems with fiber optic communication links. This approach, in which subsystems are in shielded boxes, racks, and compartments, for example, is applicable to both ground-based and airborne systems. The penetrations for power could be standardized and readily tested for effectiveness. The relatively small shielded subsystems could be individually tested against EMP in moderately sized simulators. Since EMP does not couple to the fibers, various configurations of individually shielded subsystems could be assembled with the expectation that the systems would be EMP-protected if the subsystems were. Verification of shielding effectiveness could be accomplished in several ways--for example, by continuous-wave field generators outside the shielded entities monitored by sensors inside the shielded entities. These sensors could report monitoring data by fiber optic link without any concern for coupling EMP into the shield via the reporting link.

#### CONCLUSIONS AND RECOMMENDATIONS CONCERNING PROTECTION

The principal conclusions of this chapter deal with assessability of system design, the tailored-hardening approach, and the shielding approach.

Both the design and the assessment of protection against EMP are necessarily subject to uncertainty because these processes must be conducted without exposure to actual EMP, in contrast to the situation for other forms of electrical overstress. Accordingly, the degree of assessability depends heavily on the design of the protection. Assessability is facilitated when the EMP stresses coupled into the system are limited to values small compared with nominal system voltages and currents. It should also facilitate assessability to control the uncertainties in the response of components and subsystems within a narrow range. Additionally, a protection strategy that allows large systems to be fully tested as small, individually hardened modules will favor assessability.

We strongly favor shielding, where possible, as the most assessable method of protection. Shielding, combined with careful penetrations control (such as standardized and certified power penetration methods, specialized protection for antenna leads, and fiber optic signal penetrations), satisfies our criteria of controlled attenuation of EMP stress, simplicity, modularity, and testing. Accordingly high assurance in attaining EMP protection should be demonstrable. However, complex shield geometries with numerous shield violations and patches do not generate the high degree of protection and assessability afforded by simple, continuous shields. In-service proof testing is necessary to verify that protection is maintained. The use of fiber optics will facilitate modular shielding by substituting for many metallic signal paths between subsystems, especially if the technique of multiplexing can be used.

By contrast, the tailored-hardening approach provides neither highly effective nor confidently assessable protection because of its many poorly controlled uncertainties. Nevertheless we recognize that the methods of tailored hardening are useful for improving protection of large, existing systems.

The following recommendations flow from these conclusions:

1. Protection should be implemented with regard for the cost-benefit tradeoff perceived for alternative designs.
2. Research and development should be continued to identify vulnerable components and improvements that might be made to reduce their vulnerability. The results would be useful to the tailored-hardening approach.
3. Analytical efforts should be continued on the nature of EMP coupling phenomena. The results would be useful to the tailored-hardening approach. However, we are skeptical as to the usefulness of analytical methods for describing the sensitivity of coupling phenomena to the uncontrollable details of system structure, such as cable routing.
4. Statistical design and evaluation of experiments to assess achieved hardness should be employed because the variability between near copies of a nominally similar design is often appreciable and needs to be controlled more narrowly.

## STATISTICAL TECHNIQUES IN ELECTROMAGNETIC PULSE WORK

Statistical techniques are employed to grapple with the many aspects of variability and uncertainty in electromagnetic pulse (EMP) effects. Although, for purposes of estimating vulnerability, the incident EMP, described in Chapter 2, is assumed to have fixed, nominal values, its characteristics will vary in operational situations. Unavoidable variability and uncertainty are also encountered in the degree of coupling of EMP stress into system circuits, the strength of circuit components in withstanding EMP stresses, and the analytical approximations used in estimating and combining these stresses and strengths. Even the tests conducted on systems and subsystems, to evaluate protective measures that have been applied, produce variable results that need analysis and interpretation. This chapter, together with its related appendixes, examines how statistics has sometimes been used in the EMP community and suggests some further useful approaches, interpretations, and applications of statistical and probabilistic methods.

### VARIOUS MEASURES OF VULNERABILITY

Various measures of vulnerability are useful, depending on the level of system complexity under consideration. These measures are often used in connection with the protection and assessability problems described in Chapter 3.

#### Threshold

At the component level a useful measure is the lowest stress at which failure occurs--commonly called "threshold" or "strength" (Wunsch and Bell, 1968). Thresholds are commonly assumed to be random variables, distributed over some range because of unknown variations in design and manufacture. (See Chapter 3.)

Thresholds are useful in studying the failure mechanism of electronic components so that their design may be improved. Thresholds also enter into the calculation of the failure level of a complete circuit. However, this measure is not useful by itself in assessing system performance. The reason is that the applied stresses coupled into a system by EMP are distributed with considerable uncertainty over a range of values.

#### Safety Margin

Safety margin—that is, some multiple of the difference between failure threshold, or strength, and applied stimulus, or stress—is a more useful measure than strength alone in estimating vulnerability at the component and circuit level (Egelkrou, 1978).

Stress in an actual EMP event arises from the incident electromagnetic pulse and its coupling to circuits within electronic systems. The incident pulse will vary with parameters that describe the nuclear burst, the geometry of the burst and observer, and geophysical conditions. The stress coupled to a point within the system will also vary with parameters of the system. These variations are known in fact or in principle. (See Appendix C.) However, to the extent that the values of the parameters upon which the stress depends are distributed because of uncertain knowledge or random effects, the magnitude of the stress itself is distributed.

Safety margin, therefore, is commonly assumed to be a random variable because of the unknown variations of strength and stress. The probability that safety margin exceeds some constant, say zero, may be estimated. Bounding values for this probability may then be obtained corresponding to some stated confidence level, say 95 percent. (See Appendix F.) Then this information may be used in the design and evaluation of protective measures.

#### Binary Measure

Another possible measure of vulnerability is the binary, or "go-no go," decision. This measure amounts to an assignment to a system of probability of failure equal to either one or zero. Some contract specifications appear to call for binary evaluations. We discourage the use of this measure because these extreme values of probability are not representative of real situations.

#### Probability of Survival

Probability of survival (POS) of a system until completion of a prescribed mission is another measure of system hardness and

vulnerability. The concept implies some overall, quantitative estimate--properly accompanied by some measure of its uncertainty--that a system will function as intended.

However, even to workers in the field, it does not seem to be clear how the POS approach to EMP assessment is currently defined and employed. This is one area which needs further discussion and elaboration. For example, what is the EMP community's interpretation of probability? Is it subjective or objective? Should not clear indications of how sensitive these estimates are to the assumptions and the data always be given to avoid misuse of POS? A satisfactory discussion of these issues should involve all parties involved: the Defense Nuclear Agency, its contractors, program managers for systems development, and the users of the system.

#### ON THE CURRENT USE OF STATISTICS IN THE ELECTROMAGNETIC PULSE COMMUNITY

The committee examined a wide range of statistical work undertaken in EMP vulnerability problems and judged it to be straightforward and businesslike. However, based partly on the examples to follow and partly on the collective judgment on what our statistics experts saw and heard, we believe the work lacks the depth and sophistication needed to address key issues in estimating vulnerability.

For example, there was no randomization in choosing aircraft to be tested on the TRESTLE simulator. Similarly, in tests of a critical aircraft only a small fraction of the electrical terminals was tested (Appendix B, presentation by Van Zandt, September 30-October 1, 1983). These terminals were selected in too systematic a fashion. Good experimental design requires that some test points be selected at random. Such a design partially protects the experimenter from the possibility of failing to observe unexpected effects that in fact exist but do not appear among the systematically selected test points.

There is little evidence of continuous guidance from experienced and well trained statisticians in the work on EMP described in the presentations to the committee (Appendix B) and the literature (References and Other Documents Examined by the Committee). With the exception of an occasional statistical consultant or someone with an advanced degree in statistics, past work seems to have depended mainly on statistical input from engineers or mathematicians with little or no formal training or practical experience in statistics.

As a result some difficult but important issues have not been clearly articulated or understood. Potentially fruitful uses of moderately sophisticated methods of data analysis are not cited. There is evidence of confusion regarding the use of statistical terminology and the interpretation of statistical notions. An example of such confusion, discussed at greater length in Appendix E, is the meaning and use of "confidence limits." Another example is the

interpretation of the term "probability of survival." The committee was not presented with a single example that discussed detailed statistical calculations and analyses leading to the estimate of POS for a large complex system; nor has the role of POS in decision making been well articulated in the analyses and literature brought to our attention. Uncertainties in POS values are not expressed quantitatively.

In many of the presentations and reports on threshold failure that were made available to the committee (for example, Alexander and Enlow, 1981) efforts were made to ascertain the form of the failure distributions from sparse data. However, sparse data alone should not be used to extrapolate to the tails of probability distributions. One must have some basis other than a few observations for choosing a distribution and describing its tail (Appendix F).

Documentation of long engineering and statistical experience, such as that of Parker (Appendix B, presentation on June 1-2, 1983) and Jones (Appendix B, presentation on May 21, 1983), has not been prepared. Such documentation would be useful, not only as a record of accomplishments but also as an educational aid. Although Parker has been in the business for 20 years, our visit, we were told, was the first occasion on which he had been asked to give a perspective talk on his work.

In view of these conclusions, we have included at the end of this chapter specific recommendations on the role of statistical expertise, use of statistical concepts and methods, and educational opportunities in the EMP community.

#### POTENTIAL ROLE OF STATISTICS

Statistics has played an important role in assessing the reliability of strategic systems and the safety of nuclear power plants. Statistical thinking and methodology, if seriously undertaken, can play a useful role in assessment of vulnerability to EMP. Statistical science can assist in wise acquisition of data through test and simulation design and can suggest reasonable analyses and interpretations of the data. Statistical methodology based on probability theory can provide some assessment of the uncertainty in decision-related parameters, such as probability of survival. The basic uncertainties are, however, best understood and reduced by the careful conduct of tests and application of scientific principle. Indirectly, but importantly, statistical science can contribute towards improving the hardness of a system by policing and pointing out weak spots in the system design and its hardening and identifying other such deficiencies that may be hard to detect on an intuitive basis. Thus statistics, in the context of EMP, is a device for measurement and assessment; the language of statistics enables one to express uncertainty about the EMP vulnerability of a system. The role

of statistics in EMP protection and assessment, therefore, is not merely central but is essential and inevitable.

Some useful applications of statistics at various levels of the EMP problem are given below.

#### Hardening of Transistors, Integrated Circuits, Devices, and Piece-Parts

There is available some knowledge and theory about the characteristics of electronic components and integrated circuits that affect their vulnerability to EMP and related phenomena. This understanding is far from complete, and improvement would be desirable. Improved understanding could lead to the establishment of manufacturing techniques that would reduce the extent of EMP hardening required and probably reduce the extent of other types of failures too.

One sign of the potential usefulness of more understanding is that tests have shown that components manufactured by different suppliers to meet the same specifications vary widely in their vulnerability to test pulses of voltage and current. Experiments have been carried out to help determine the characteristics of manufacture that influence the hardness of these components. At least one of these tests (Alexander, Enlow, and Karaskiewicz, 1980; Alexander, Karaskiewicz, and Enlow, 1981) has yielded vast amounts of data, but no investigation has made more than a naive analysis of these data up to the time of this report.

With the help of statistical knowledge in such areas as life testing, design of experiments, multivariate analysis, goodness-of-fit tests, graphical analysis, and threshold estimation, and with the cooperation of physical scientists working on components and circuits, it seems likely that more efficient experiments and system and subsystem tests could be performed and that more useful results could be derived from the analysis of the data. In Appendix F some ideas are outlined for improvements in statistical estimation of safety margins based on stress-strength models.

#### Testing at the Medium, or "Box," Level

The level of the functional circuit, or "box," is intermediate between circuit component and subsystem. If hardness can be measured by achieved margin and if tests are conducted that yield appropriate data, then statistical ideas can be used in such test design and analysis. Statistical methods, including analysis of variance and regression studies of survival data, can help characterize variability in achieved hardness (margins) between boxes under different test conditions. Modern statistical methods, involving computer graphics, for instance, can point up unsuspected sources of variation and

opportunities for better understanding and improvement. Thus tests on the well-shielded box can be evaluated. Because of testing limitations and anticipated variability, statistics will play a role in characterizing the extent to which planned margins of, say, 100 decibels are achieved. That is, it will be useful to quote standard errors, probability limits, or confidence limits to describe variability between copies and to characterize and account for the effects of measurement error.

### Testing and Evaluation of Large Systems

Large modern systems have not been exposed to EMP from an actual nuclear device. Thus, we must depend on simulations and on theoretical models relating the simulation tests to real EMP. We hope that there are no highly unusual effects that have not been foreseen in the models. We must be aware of that possibility, however, and be alert to avoid surprises. Chapter 3 discusses some limitations on the fidelity of the simulation and on the type and quantity of data that may be taken. These limitations, of course, increase the uncertainties of the test results.

Large systems such as the B-52 aircraft, the B-747 aircraft, the command-post helicopter, and buildings on a base can be tested in a limited manner, such as is done on the TRESTLE EMP simulator. Such tests are expensive, but they may well be much less so than the costs of operational failure.

First-rate statistical effort will help to answer the following important questions:

1. How should one choose a copy or copies of the system to be tested? To what extent should the choice be randomized? How does one understand the variability between copies and extrapolate to other copies?
2. How should one choose a subset of the possible points on the system that can be tested?
3. How should the principles of accelerated life testing be used in devising such tests and interpreting the results?
4. How may one economize on the amount of testing done?
5. How should test data be combined with engineering opinion?
6. How should expert opinion be revised as a result of test data?
7. How should decisions be made regarding the hardness of the system based on the results of the test? For example, what experimental results should lead to the modification of the system design or more hardening or the decision that present hardening is adequate?
8. How may test design help to characterize the physical sources of uncertainty?



By contrast, this committee had very little indication of how the data from the TRESTLE simulator tests are analyzed and what, if any, conclusions have, or can be, drawn from these tests about the general principles of EMP hardening.

#### Assessment of Huge Systems That Cannot Be Tested

Huge systems, such as the national power transmission system and the telephone system, cannot be tested as a whole. The best approach in these cases may be statistical models. The techniques of fault tree analysis could be very useful. Fault tree analysis seems to be a natural methodology for deriving quantitative estimates of hardness of such large systems. Bayesian methods may well allow assignment of meaningful uncertainty statements on probability of failure.

However, there are difficulties; these will have to be overcome by a careful analysis and detailed considerations. Examples are how to integrate properly the individual parts of an analysis and how to treat independence or lack thereof. We emphasize that analysis can only produce guidelines. Valuable as the resulting guidelines may be, every attempt must be made to check for their plausibility and their implication for policy. Some work has begun on the application of Bayesian methods to estimating vulnerability of huge systems to EMP (Appendix B, presentation by Newman, April 1-2, 1983; Appendix B, presentation by Mensing, August 9-10, 1983).

#### Verification of Shielding Integrity

A key element in protection by shielding is assuring that an adequate shield is maintained. One possible approach to verification is to incorporate automatic testing equipment to monitor the extent to which shielding is being maintained. It is plausible that sound statistical quality control can be employed to detect deterioration of shielding quality well before the deterioration becomes dangerous or difficult to repair. Automatic test equipment is itself susceptible to failure and the generation of false alarms. Statistical modeling and reliability theory can be used to evaluate the probability of false alarms. The goal is to increase alarm sensitivity to true threats to security without unduly increasing the false alarm rate.

#### WHAT IS PROBABILITY?

Estimating vulnerability to EMP effects deals inherently with uncertain events. It may be cogently argued that the most meaningful way by which to express uncertainty about an event is in terms of

probability. Therefore, some discussion of basic aspects of this concept is in order as a foundation for its useful application. The mathematical theory of probability is an abstract theory based on a few axioms relating the terms, probability and event. This theory need not have anything to do with the real world until probability and event are given concrete interpretations in the real world. Then the conclusions from the theorems of probability will apply to the situation at hand. Two alternative interpretations of probability have attained practical importance.

#### Frequentist Interpretation

One possible interpretation for a theory of probability is the frequentist one. Consider an experiment, such as coin tossing or card shuffling and play, which may be repeated under similar circumstances many times and for which the outcomes may be different. An event is considered to be a subset of the possible outcomes. The event occurs or succeeds if the outcome of the experiment is in the event. The probability of that event is the long-run proportion of times that the event occurs or succeeds--that is, its relative frequency of occurrence. The applicability of the mathematical theory of probability is tied to the assumption that, as the number of repetitions (trials) increases indefinitely, the proportion of successes of an event will tend to a limiting value. While this assumption cannot be checked directly by repeating an infinite number of trials, it can be tested by checking whether predictions based on the theory of probability are reasonably well satisfied. For example, suppose a coin were tossed 10,000 times and one noted the difference between the numbers of heads in the first 5,000 tosses and the second 5,000. It would be surprising, if the usual theory (Bernoulli trials) were appropriate, to find that this difference were more than 100. It would be very surprising if the difference were more than 150. Or to turn it about, experimental determination of the parameters of the probability model will be in some error; but the theory may be used to characterize the errors.

The frequentist interpretation is not adequate to handle some applications. For example, this interpretation is difficult to apply to situations where the experimental setup is not easily replicated. Thus, the economist who wishes to apply probability theory cannot repeat experiments under similar circumstances, since changes that have major influences on the outcomes are always taking place. Some philosophers then like to think in terms of conceptual repetitions. Others prefer to test theories involving probabilities by seeing how well their predictions are satisfied. In effect the probability model is tested as part of the theory. Thus, a theory that assigns probability greater than 0.9 to each of 50 independent events will not be well supported if only 30 of these occur. (See Savage, 1962; Luce and Raiffa, 1957.)

### Subjective Interpretation

Another interpretation of probability is a subjective one, which measures probability in terms of conditions under which one is willing to bet. For example, if you are offered \$1 to predict correctly the outcome of the toss of a possibly biased coin, your considered choice of a head would mean that your subjective probability for heads is at least 0.5. Your probability could be narrowed by considering your choices in a variety of bets where the reward depends on the outcome of the coin toss.

This interpretation satisfies the axioms of probability if one assumes that your choices satisfy some assumptions of consistency and rationality (Savage, 1962). These assumptions form the justification for the so-called Bayesian, or subjective, method of statistical inference. This method is a useful, formal way of quantifying one's degree of belief concerning the uncertain outcomes of experiments. Degree of belief, as expressed by subjective probability, can be, and should be, based on informed and scientific opinion. In this approach the statistician expresses his uncertainty in terms of prior probability distributions on the unknown. After observing the results of the experiments, one applies Bayes' theorem to compute posterior probabilities given the data. The role played by data, then, is to revise previously held opinions.

There are, it turns out, variations on the above theme (see, for example, Jeffreys, 1961; Lindley, 1965; Shafer, 1976; Dempster, 1967; Dempster, 1968). But the appealing attribute of Bayesian statistics is the ease with which personal probability assessments and data may be combined to produce a final statement of the belief probability of various uncertain outcomes of some process on the basis both of prior probability distributions and of data.

### Relative Appropriateness of the Interpretations

There has been controversy among statisticians about the relative appropriateness of the Bayesian approach and the more classical objective, or frequentist, approach to statistical inference. In the latter approach the unknown probability of the biased coin falling heads is regarded as an unknown state of nature, which is constant (nonrandom) and not subject to the laws of probability. The objective is to use data to make inferences about the unknown state of nature, on which wise decisions can be based. By contrast, the Bayesian expresses a personal uncertainty about this unknown quantity in terms of a (prior) probability distribution, effectively treating it as if it were random.

However, the practice of statistics, that is, the art of the recovery of information or learning from data, does not depend vitally upon the interpretation of probability that is chosen. Much useful

statistical work, along the lines of preliminary investigation or the exploratory data analysis of Tukey (1977), makes little to no use of probabilistic notions. In truth, there are detailed disagreements concerning the meaningfulness of such concepts and tools as classical confidence limits, hypothesis tests, and significance levels. From a strict Bayesian viewpoint the classical methods are "inadmissible." Nevertheless, they provide useful tools. Strict classical statisticians, and some Bayesians, are concerned with the trust to be put in subjective probability assessments. They object to conclusions based on subjective prior probability distributions, which indeed may not be unique when various experts are involved. Bayesian analyses that rely heavily upon subjective assessment of probability weights may be expected to differ in their implication for decisions. It is reassuring that Bayesian parameter estimates and confidence limits often differ only slightly from classical estimates and confidence limits, provided the Bayesian utilizes a rather gentle, vague, or non-informative prior distribution and there are considerable data. If a person, acting as an expert, assigns a highly informative or influential prior distribution, then numerical results--and decisions--can be much affected. Sizeable amounts of data are required to alter a "sharp" prior influence via Bayes' theorem. Assessment of the compatibility of prior distribution and data has been discussed by Dawid (1973).

The objective statistician may find it difficult to make formal, probabilistically supported decisions if there are few or no data. The Bayesian may prefer to gather evidence, but can make decisions without directly relevant data if forced to by circumstances. Thus, situations that require decisions in circumstances where there are few experimental data and some prior beliefs sometimes make the use of Bayesian inference rather compelling.

Quantitative assessments of survival probabilities can indeed be elicited from experts, the prior distribution combined with whatever data exists, and the results used for decision-making purposes. This process should, however, be subjected to very careful critical scrutiny, diagnostic checks, experimental verification by testing of subsystems, and continued attempts to validate the experts themselves with a view to comprehending the basis of their numerical statements. For some discussion of personal probabilistic assessment biases see Kahneman, Slovic, and Tversky (1982). The natural tendency to be beguiled by the smoothness of the Bayesian calculations should not limit the constant attempt to examine critically the decision-influencing consequences, especially in areas as important as EMP.

Members of the EMP technical and decision-making community should understand these issues. In particular, one should realize that, were probabilities to be calculated under both approaches, there would be no logically tenable way of combining or relating the two probabilities; they would have entirely different meanings. The

thrust of work in the area should be to reduce uncertainty, by careful scientific work, and then to account for what uncertainty remains when decisions are to be made.

## SOME APPLICATIONS OF PROBABILITY

### Application to Fault Tree Analysis

Fault tree analysis is a systematic method of tracing the effects of failures at lower levels of system upon its higher levels. The method, successfully used in risk and reliability analysis, can also be used to estimate probability of survival for complex systems and to compare various hardening approaches, such as tailored hardening versus shielding. A tutorial on fault tree analysis appears in Appendix G. A byproduct of such analysis is that weak spots in the system may be identified and may serve as a guide to engineers on what needs hardening. Another byproduct is the ability to rank the various subsystems in a system with respect to their hardness.

This type of analysis has certain problems associated with it. For example, all the relevant modes of failure are assumed to be identified. Implicitly this assumption means that the analyst does not omit from the model hidden weakness, such as human error or unusual failures, and that the analyst understands the relationship of the various parts of the system well enough to model them accurately. Thus, cooperation between the fault tree analyst and the system designer is essential for the successful construction of a fault tree.

The simplest form of fault tree analysis assumes that each component (or basic node) has a known probability of success, independent of other basic nodes. However, for a sophisticated system one may have to deal with dependencies by introducing conditional probability models relating the dependencies of the failures at the basic nodes. Intimate knowledge of system dependence upon components is necessary for this procedure to be credible. One will certainly have to deal with the fact that many probabilities are not known and may have to be estimated on the basis of very few or no data.

The last complication suggests that the analysis be carried out in a Bayesian framework, which involves the subjective judgment of engineers and the analysts. Thus, for each basic node, a posterior distribution of probability must be obtained based on a prior subjective judgment compounded with observed data, if any. Calculations, which are straightforward in principle but complex in execution, will convert the nodal posterior distributions to a posterior distribution for POS. That is to say, different values of POS will be assigned different weights.

Thus a fault tree analysis will yield a probability distribution of the probability of system survival, conditional upon the level of an

imposed threat. If certain prior probability distributions are sufficiently vague and very few data are available on the related components, the eventual distribution of POS may be so broad as to be useless as a guide for action. In that case it may become important to invest in gathering more relevant data, if possible, or, if not, to question carefully the subjective inputs. Alternatively, if the prior distributions that are assigned have strong influence, then expert judgment should be used to validate them.

One of the weaknesses of the above approach is that if the subjective prior distributions are not specified carefully and without bias, the conclusions may be unduly distorted and misleading. Thus, it is desirable to develop methods of analysis that evaluate the sensitivity of the conclusions to variations of the information (models, prior distributions, and data) on which calculations are based. During the analysis constant and unceasing attempts must also be made to validate its quality and the defensibility of the decisions that result from it.

#### Applications to Some Other Statistical Techniques

The distinction between objective and subjective probability is blurred in most statistical practice. All statisticians acknowledge, for example, that certain statistical models promise to be useful in certain circumstances; for example, the normal (Gaussian) distribution often describes measurement or ballistic errors reasonably well, whereas the exponential distribution better describes certain times to failure. Selection of such models to aid decision making is certainly subjective, but such selection is usually agreed to be best accompanied by considerable attention to sensitivity of the decision to overall model inadequacy. Surprises that experts did not anticipate will occur, and the effects must be capitalized upon or forestalled. Present-day attention to robust procedures (both Bayesian and frequentist) has this objective. Subjective prior distributions for unknown quantities should be carefully checked for their influence on the final decision, especially if the data are sparse or negligible.

Two further ideas may be useful for EMP problems. The first idea embraces the Empirical Bayes and the Bayes Empirical Bayes methods; both recognize variability between individual copies of designs, be they individual coins or EMP-shielded systems. Such variability is usefully characterized mainly in terms of systematic explanatory variables, but additionally in terms of random variability described by a superpopulation. Test results for box-level system components may well be usefully summarized in an Empirical Bayes fashion. The second idea is that hardness, or invulnerability, may be conveniently and usefully characterized in physical terms, for example, in terms of margin, measured in decibels (dB). Both strength and stress may be

considered to be random variables. The "probabilistic" statements in this case are all assessments of the uncertainty with which a safe level of margin, such as 100 dB over background, is achieved. The notion of margin may be more familiar than POS to engineers, and POS may be more useful to decision makers.

#### Application to Probability of Survival

It is not clear how probability of survival was interpreted nor how it was calculated in some of the applications described in presentations to the committee (Appendix B). In those presentations, there seemed to be much confusion with regard to POS. For example, Chodorow (Appendix B, presentation on September 30-October 1, 1983) asks, for a one-of-a-kind system, "What can I do with POS?" The terms probability of survival, in particular, and probability, in general, require careful interpretation.

As a hypothetical example, what does it mean to estimate that the POS of an aircraft under an EMP threat is 0.40? The fact that the hypothetical 0.40 is an estimate suggests that the true unknown probability being estimated is somewhere near 0.40. Just how near becomes an important question. Even if it were granted that the POS is exactly 0.40, there still is a problem of interpretation. Does it mean that, if 100 such aircraft were flying when an EMP burst took place, about 40 of these would survive to carry out their function? Or could this value of POS be consistent with the following scenario, where either all or none of the aircraft survive? Suppose that the POS is calculated assuming that with probability 0.40 the field strength of the EMP is, say, 5 kilovolts per meter (kV/m) and with probability 0.60 it is, say, 50 kV/m. Suppose also that our calculations indicate nearly 100 percent as the probability of survival for the lower field and nearly 0 percent as the probability of survival for the higher field. Then, with probability 0.40, all of the aircraft would survive and, with probability 0.60, none would survive. The example also illustrates the need to specify the POS as a function of the magnitude of the EMP attack for the benefit of the designer, the pilot, and the force commander.

It is clear from the above, that for one-of-a-kind systems, POS cannot be interpreted as is done in the actuarial sciences, where a great deal of comparable survival data are available. Thus, POS should be cautiously viewed as a relative index of the hardness capability of the system.

The issue of relating POS to various relevant circumstances was not clearly brought out in the presentations to the committee. POS is necessarily conditional, conditioned on a criterion threat level, the number of EMP bursts, and other operational parameters. Chapter 2 notes the availability of interim threat criteria.

There is also some question about how one should evaluate hardness, as measured by POS, when the results are based on complex calculations

involving many prior distributions approximating subjective judgments and feelings that may not be as consistent as theory demands them to be. Ideally, Bayesian analysis should lead to a realistic, trustworthy probability distribution of POS values. If the distribution is highly concentrated on low values, softness exists. If it is highly concentrated on high values, we have hardness. If it is spread broadly, then there is at least potential softness. In the first and third cases, the analysis may point to weak spots, which require hardening. In the second case, where we have hardness, how well can that conclusion be trusted? Sensitivity analysis will help tell us, provided that we trust the structure of our fault tree. Suitable validation procedures are required.

One may argue that this type of analysis is not trustworthy and that quantitative conclusions can easily mislead decision makers, who may give undue weight to numerical values based on questionable assumptions. The alternatives seem to be to use some vague collection of semiquantitative statements or to reduce the conclusions to "a warm or cold feeling" about the hardness of the system. It is difficult to see how wise policy decisions on how much to spend on hardening can be based on warm feelings alone.

#### GENERAL GUIDANCE ON DIFFERENT KINDS OF "STATISTICS"

In our judgment, it is most important for readers of this report to be clear about the different roles played by "statistics" in the following subjects:

1. Statistical mechanics.
2. The analysis of randomized experiments.
3. Reliability analysis through fault trees.
4. The analysis of data of experience, like climate and the stock market.
5. Bayesian-based estimates of reliability.

There are circumstances where each is the best that one can do, but what each honestly promises to do is quite different. An important reason why we are concerned with careful use of probability-related words in connection with EMP is the danger that a misused word will give rise to a misinterpreted meaning, and thence to a much greater (or conceivably much lesser) trust in some number than that number deserves.

It is not enough that the numbers that come out of an EMP analysis are as good as is possible at a particular time--it is essential that the recipients of the numbers understand the uncertainties and liabilities that surround them. So let us go through the five items above, discussing their necessary assumptions and the amounts of trust that their answers can reasonably bear.



Statistical mechanics, both classical and quantum, is based upon general theoretical assumptions, whose consequences have been tested in widely diverse situations. If we understand the physical processes and characteristics involved, the results of statistical mechanics are as trustworthy as those of deterministic physical theory.

When the measurements and the imposition of treatments and background conditions are done with the utmost care, and when the assignments of treatments to experimental units is as nearly truly random as we know how to make them, the detailed results of randomized experiment are the safest results we know how to obtain; and if we use appropriate statistical techniques, the same is true for the summarized results.

These two illustrations involve some of the most trustworthy analyses that we know how to make.

Fault trees have proved very useful in studying and improving reliability. But any numerical answers they provide are no better than the information that went into them. While they are very useful in helping engineers and scientists to think about particular questions of reliability, their use does not guarantee that their users have thought of all the combinations of failures that could be critical. Indeed, experience suggests that this rarely happens. Sometimes the information put into them about the probability of individual failures is based on experiment, or even experience. Too often, of course, absent such trustworthy information, it has to be based on the best skilled judgment. It is usual to treat individual failures as independent--mainly because it is believed that no one knows better. All these possibilities--unnoticed combinations, judgment estimates for individual failures, and inability to allow for correlated failures--tend to make the overall numbers more optimistic than they should be. We should use fault trees more widely, not only because they encourage careful thought but also because they sometimes allow helpful comparisons. However, in so doing, we should keep a supply of large grains of salt close at hand.

The analysis of data of experience, illustrated by the studies of weather and climate on one hand, and by those of the stock market on another, has made good use of statistical techniques; but again we are likely to have missed important relationships of dependence, both in average performance and in deviations. Again the use of statistical procedures is usually the best approach we have; again the final numbers, though often helpful, are likely to be over-optimistic, at least as far as the width of the remaining uncertainty. Again we ought to use such techniques, well sprinkled with large grains of salt.

Bayesian techniques are often misunderstood by the non-professional. Their results are usually stated in terms of posterior probabilities--which are not thought by Bayesian statisticians as how frequently something will happen or how frequently some system will survive. The professional Bayesian understands his or her techniques as ways to combine degrees of belief

about individual elements into a degree of belief about the system as a whole. Not only is such an analysis of reliability subject to all the defects just described in connection with fault trees, but it relies more on individual judgments and conventional choices of prior distributions than non-Bayesian fault-tree analyses--if such are possible for a particular system at a particular date. Again they may well be the best that can be done for a particular system at a particular time, but we must be very careful to equip the posterior probabilities thus obtained with oversize grains of salt and warning about their lack of a trustworthy frequency interpretation. We should not avoid their use, which may well be essential; but we should be most careful not to take their final results as gospel--neither as written on tablets of stone nor as reliable approximations to predicted frequencies.

Whatever approaches to a specific problem are possible, we should choose the most trustworthy among them, and use it. But we dare not misinterpret its results.

Some use "statistics" as a way of sanctifying results. Accordingly we may need to attach the label "unsanctified" as a flag on results obtained in ways widely different from those which are generally agreed to deserve the most trust. While views of Bayes techniques differ, most--and we believe most Bayesians--would not feel that either their purpose or their functioning is one of sanctification. One reason we have emphasized the need for the involvement of more professional statisticians in EMP activities is the difficulty of pressing forward Bayes techniques, where they are the best we can do, while at the same time avoiding undue belief in the numbers they provide us.

When a quite uncertain number is the best that can be had, it may be important to get it and important not to throw it away--but even more important not to take it too seriously.

Since there is no way to base an analytical estimate of EMP vulnerability on first principles, there can be no substitute for the best physical simulations possible as a route to adjust and improve the results of analytical studies.

#### CONCLUSIONS AND RECOMMENDATIONS CONCERNING STATISTICS

The preceding sections of this chapter draw a number of conclusions in the course of specific discussion. The principal ones are recapitulated here.

First, the statistical techniques applied so far in the estimation of vulnerability to EMP effects have been straightforward but lack the depth and sophistication needed to address many of the key issues. Clarity is lacking in the definition of key concepts, such as probability of survival, and of terminology, such as confidence limits.

Second, the potential role of statistics in EMP protection and assessment is not merely central, but is essential and inevitable at several levels of the EMP problem. Statistics is well suited to characterize certain properties of large populations of piece parts and the quality control of shielding. Statistics can improve the design of tests and the evaluation of results at both the subsystem and system level. For huge systems that cannot be tested as a whole, certain statistical methods provide a framework for compounding performance estimates for portions of the system into performance estimates for the whole system.

Next, fault tree analysis may be useful in comparing various hardening approaches. Fault tree analysis may also be a useful approach to indicating the relative probability of survival for complex systems. However, probability of survival is not yet adequately defined and interpreted to allow its use as a firm measure of vulnerability.

Also, situations that require decisions in circumstances where there are few experimental data and some prior beliefs sometimes make the use of Bayesian inference rather compelling. When Bayesian inference is used, however, it should be subjected to critical scrutiny, diagnostic checks, experimental verification by testing of subsystems, and attempts to validate the expert opinions used.

Finally, of the various kinds of statistical approaches to a given problem that may be possible, we should choose the most trustworthy among them and use it. But it is essential that the users of the results understand the uncertainties and liabilities that surround them.

In view of these conclusions, we make the following recommendations:

1. The EMP community, including its management, should be better educated on the key ideas and notions of statistics and reliability. Improved standardization of statistical terminology used by the EMP community should be pursued in order to reduce confusion with respect to its interpretation and uses.
2. The government should utilize qualified and experienced personnel, well trained in statistics, to oversee contractors' bids and work that involve statistics.
3. Collaboration among statisticians, engineers, and physicists working on the field of EMP protection and assessment (a good example being the team of Alexander, Enlow and Karasciewicz) should be encouraged. The statisticians on such teams should be well versed in the latest techniques and developments in statistical methodologies and reliability.
4. Contract specifications that may be interpreted to require survival with probability equal to one (that is, certainty) should be avoided. Such specifications can lead to misunderstanding and legal problems, as well as to a poor choice of contractors. We recommend, rather, a collection of

tests, such that passing all will be acceptable as satisfaction of EMP requirements.

5. Because fault tree analysis is a useful management tool, it should be utilized in EMP work where it is applicable. Both empirical and theoretical research may be required to tailor fault trees to the particular needs of the EMP problem.
6. The Defense Nuclear Agency should establish a number of postdoctoral fellowships closely integrated with the field of EMP protection and assessment. The fellowships could be administered so as to encourage interdisciplinary collaboration, attract new talent to the field, and supplement the ongoing programs.

CONCLUSIONS AND RECOMMENDATIONS

Estimating vulnerability of systems to electromagnetic pulse (EMP) effects depends greatly on the nature of the system. The soundest results can be obtained where stress within the system is controlled, through integral shielding and penetration-control devices, to well known values. In this case, one can rely on engineering analysis and systematic testing of a predominantly deterministic nature. Where control and knowledge of stress, as well as of strength, are not possible because of system design, complexity, or uncontrolled changes, probabilistic estimates become necessary. Statistical methods for estimating and combining uncertainties, fault tree analysis, and Bayesian inference may be used to systematize the estimates of vulnerability. However, repeated testing of systems, and subsystems, at as high a simulated threat level as possible, is essential with this approach. Whatever method is used, the uncertainty of the result should be clearly emphasized to decision makers lest oversimplification result.

In our charge, and in the composition of the committee, there was a great emphasis on statistical issues. The committee, through its statistical panel, investigated such issues thoroughly. We found that in past work rather unsound and vague statistical meaning seems to have been given to such key ideas as "probability of survival" and "confidence limits." Further, for systems, as opposed to components, we do not believe that reliable numbers of this sort can be inferred statistically from the sorts of data available. In spite of such inability to give unambiguous results, statistical thinking and methodology must play a primary role in evaluating the susceptibility to EMP of existing large systems. The reason is that statistics may be the most appropriate and available methodology when full-scale testing, redesign, and extensive modification do not seem possible for systems like the national telephone network and the national power grid.

Confident assessment of the degree of protection of most, if not all, military systems is contingent on a design making the system assessable. In assuring against failure or dysfunction caused by EMP, effective design and, especially, effective shielding, together with a

continual monitoring of the effectiveness of such shielding, must have a primary role and statistics, a supporting role.

With these two different perspectives in mind, we present our conclusions and recommendations in two parts--the first concerning general conclusions and recommendations on protection and the second concerning statistical matters specifically.

#### CONCLUSIONS AND RECOMMENDATIONS THAT WE BELIEVE VITAL IN PRODUCING ASSESSABLE MILITARY SYSTEMS PROTECTED AGAINST EMP

No one committee or study can settle forever the most productive course and program to be followed in assessing the degree of EMP protection of assets vital to military missions. Therefore, we recommend a continuing program:

1. There should be a continued reappraisal of the threat, its consequences, and the best near-term practices and longer-term research needed for meeting it.

The heart of the EMP problem is to ensure completion of necessary missions after exposure to EMP. Completion of missions obviously depends on the continued operability of mission-essential systems, such as navigational and weapons systems in aircraft. Initiation and completion of missions will also depend on proper functioning of some communications and support systems. It is essential that such systems, subsystems, and support systems continue to function after exposure to EMP. It is not essential that the cost of protecting nonessential systems be incurred. Accordingly, selective effort is desirable:

2. Adequate analyses should be made of what systems, subsystems, and support systems are essential to completion of mission.

The two principal approaches to EMP protection are integral shielding of a complete system and tailored hardening of selected parts of it. In the latter approach, these parts are selected after analysis of the stresses expected to be coupled into them. Some problems can be treated analytically--such as the fields around aircraft, coupling to antennas, and some forms of coupling to the interior of an aircraft. However, great and continuing uncertainties persist in predicting levels of voltage and current on wires and on components in boxes. Uncertainties in the damage thresholds of military specification (MILSPEC) components persist. The question of circuit upset, short of damage, is not well addressed by the analyses of tailored hardening. Finally, in systems protected by tailored hardening and later tested, large deviations from predicted results occurred and unpredicted responses were noted. For these reasons the

tailored-hardening approach seems lacking both in the actual control of protection and in the assessability of it. By contrast, shielding with control of penetrations of the shield can be simple, modular, standardized, and verifiable by test. Reduction of EMP-induced electrical stress inside the shield to levels similar to those in normal operation renders the protection of the shielded unit independent of minor variations, associated with manufacturing and maintenance, in configuration and components. Consequently shielding is the preferred technique:

3. There should be great emphasis on achieving assessability by promptly developing better and cheaper means for virtually complete and effective shielding of systems essential to the completion of mission. This objective should include a strong emphasis on early use of standardized shielded boxes interconnected with optical fibers.

The committee finds that, in view of uncertainties in component thresholds and circuit analysis, assessable means for providing survivability must come through testing to assure that qualifications are met. Testing that demonstrates the continued hardness of the system must also be carried out because there are always ongoing changes in the system and because even minor changes made by naive workers can reduce hardness. In the case of tailored hardening, testing must be at or near threat level. In the case of virtually complete shielding, testing can be chiefly directed at continued effectiveness of the shielding, with high-level testing of penetrations only. Clearly, testing is indispensable:

4. There should be a program to study and devise and evaluate the best and most economical way for continual testing to assure the maintenance of hardness.

A good deal of material is available on the hardness of components; but the statistically characterized range of hardness of particular MILSPEC components is large, the understanding of mechanisms of failure is inadequate, and at least some statistical and test methods that have been used are suspect. Some systems exposed to EMP will not be completely shielded. Thus, component failure needs study:

5. There should be a better understanding of the mechanisms of component failure and better and more insightful component tests and interpretation of test data.

Not only components but also functional circuit aggregations, or "boxes," can be tested at high levels. As in the case of components, the performance of entire circuits needs to be well understood:

6. There should be increased emphasis on thoroughgoing analysis, testing, and comparison of analysis with test at the level of functional circuit aggregations, or "boxes."

The assessment of EMP hardness is of necessity based upon the prediction of the effect of EMP upon components, subsystems, and systems. There exists a variety of techniques for making such predictions--for example, theoretical analyses, tests using low-level electromagnetic fields, and statistical inference. However, at present the significance and reliability of such predictions remain unclear. Prediction and test need to reinforce each other:

7. A long-range program should be initiated and directed toward the systematic validation of prediction methods. The TRESTLE and comparable high-level simulators constitute a promising avenue to that end. These simulators generate pulses that are similar in many ways to, but also significantly different from, the expected EMP event. Important insights into the credibility of prediction methods themselves could be obtained by employing these methods to predict the response of components and systems to the fields known to be produced by the simulators and by confirming those predictions with experiments using the simulators.

#### CONCLUSIONS AND RECOMMENDATIONS CONCERNING STATISTICS AND STATISTICIANS

Statistical methods are difficult to apply to the assessment of the effects of EMP, because the coupled stress (1) is atypical and not well understood experimentally and (2) may simultaneously damage or disrupt many systems elements. Moreover, the lack of ample data under the threat-level environment is a serious obstacle to the validity of vulnerability estimates. The popular instinct that statistical methods should be easy to apply derives from experience with (1) thoroughly researched phenomena and (2) independent element failures in a large system. Analogous statistical problems are faced by the U.S. Nuclear Regulatory Commission in radiation risk assessment. Bayesian methodology was the dominant one used there.

The statistics panel found weaknesses in the statistical work done in connection with EMP. With few exceptions, work seems to have been conducted by engineers or mathematicians with little or no formal training or practical experience in statistics. Difficult but important issues have not been clearly articulated or understood. There has been evidence of confusion--likely to lead to serious misunderstandings--regarding the use of statistical terminology and the use of statistical notions. Contracting agencies have not been well advised concerning the soundness or usefulness of statistical



work laid out in proposals. Toward remedying this situation, we present the following recommendations:

1. The EMP community, including its management, should be better educated on the key ideas and procedures of statistics and reliability. Improved standardization of statistical terminology used by the EMP community should be pursued in order to reduce confusion with respect to its interpretation and uses.
2. The government should utilize qualified and experienced personnel, well trained in statistics, to oversee contractors' bids and work that involve statistics.
3. Collaboration among statisticians, engineers, and physicists working in the field of EMP protection and assessment should be encouraged. The statisticians on such teams should be well versed in the latest techniques and developments in statistical methodologies and reliability.
4. Contractual specifications that may be interpreted to require survival with probability equal to one (that is, certainty) should be avoided. Such specifications can lead to misunderstanding and legal problems, as well as to a poor choice of contractors. We recommend, rather, a collection of tests such that passing all will be acceptable as satisfaction of EMP requirements.
5. Because fault tree analysis is a useful management tool, it should be utilized in EMP work where it is applicable. Both empirical and theoretical research may be required to tailor fault trees to the particular needs of the EMP problem.
6. The Defense Nuclear Agency should establish a number of postdoctoral fellowships closely integrated with the field of EMP protection and assessment. The fellowships could be administered so as to encourage interdisciplinary collaboration, attract new talent to the field, and supplement the ongoing programs.

REFERENCES AND OTHER DOCUMENTS  
EXAMINED BY THE COMMITTEE

- Alexander, D. R., J. B. Almassy, G. L. Brown, D. L. Durgin, C. R. Jenkins, R. N. Randall, A. Unwin, and J. J. Schwartz. 1975. Electromagnetic Susceptibility of Semiconductor Components. Final Report. Kirtland Air Force Base, New Mexico: Air Force Weapons Laboratory (AFWL-TR-74-280). September.
- Alexander, D. R. and E. W. Enlow. 1981. Predicting lower bounds on failure power distributions of silicon NPN transistors. IEEE Transactions on Nuclear Science NS-28(6):4305-4310. December.
- Alexander, D. R., E. W. Enlow, and R. J. Karaskiewicz. 1980. Statistical variations in failure thresholds of silicon NPN transistors subjected to electrical overstress. IEEE Transactions on Nuclear Science NS-27(6):1680-1687. December.
- Alexander, D. R., R. J. Karaskiewicz, and E. W. Enlow. 1981. Component Statistical Characterization. Final Report. Part 1 of 4. Kirtland Air Force Base, New Mexico: Air Force Weapons Laboratory (AFWL-TR-80-128, Pt. 1). September.
- Ashley, C. and J. V. Locasso. 1977. A Brief Presentation and Discussion of the Algorithm Used to Determine EC-135 EMP Margin Reliability-Confidence. Kirtland Air Force Base, New Mexico: Air Force Weapons Laboratory and Rockwell International Autonetics Group (System Design and Assessment Note 23). September 27.
- Baker, G. H. and W. H. Hardwick. 1982. Electro-optics applications for alleviating EMC/EMP/EMI problems. Pp. 75-85 in Proceedings, Emerging Technology--A Bridge to the Twenty-First Century, IEEE Region 5 Conference and Exposition. Colorado Springs, Colorado. May 3-8.
- BDM Corporation. 1980. Electronic Component Modeling and Testing Program. Final Report. Kirtland Air Force Base: Air Force Weapons Laboratory (AFWL-TR-78-62 Pt. 1). March.

- Bell Telephone Laboratories, Inc. 1975. EMP Engineering and Design Principles. Second Printing. Whippany, New Jersey.
- Bevensee, R. M., H. S. Cabayan, F. J. Deadrick, L. C. Martin, and R. W. Mensing. 1979. Probabilistic Approach to EMP Assessment. Livermore, California: Lawrence Livermore Laboratory. Unpublished. August.
- Bevensee, R. M., H. S. Cabayan, F. J. Deadrick, L. C. Martin, and R. W. Mensing. 1980. Characterization of Errors Inherent in System EMP Vulnerability Assessment Programs. Livermore, California: Lawrence Livermore National Laboratory (UCRL-52954). October 1.
- Boeing Company. 1975. Survivability/Vulnerability Safety Margin Assessment. Washington: Defense Nuclear Agency (DNA 3859Z). September 30.
- Brown, W. D. 1972. Semiconductor device degradation by high amplitude current pulses. IEEE Transactions on Nuclear Science NS-19(6):68-75.
- Cianos, N. and E. T. Pierce. 1972. A Ground-Lightning Environment for Engineering Usage. Technical Report 1. Menlo Park, California: SRI International.
- Clement, D. M. and A. W. Johnson. 1981. Satellite survivability estimates. IEEE Transactions on Nuclear Science NS-28(6):4198-4203. December.
- Crain, C. M. 1982. Calculation of Radiated Signals from High-Altitude Nuclear Detonations by Use of a Three-Dimensional Distribution of Compton Electrons. Santa Monica, California: Rand Corporation (N-1845-ARPA). March.
- Dasiac: DOD Nuclear Information and Analysis Center. 1982. Bibliography of Semiconductor Device Modeling for EMP and TREE Effects. Santa Barbara, California: Kaman Tempo. 29 November.
- Dawid, A. P. 1973. Posterior expectations for large observations. Biometrika 60(3):664-667.
- Defense Nuclear Agency. 1983. Report of the DNA Electromagnetic Pulse (EMP) Review Committee (U). Washington (DNA-83-05668). August.

- Dempster, A. P. 1967. Upper and lower probabilities induced by a multivalued mapping. *Annals of Mathematical Statistics* 38:325-339.
- Dempster, A. P. 1968. A generalization of Bayesian inference. *Journal of the Royal Statistical Society* B30:205-232.
- Egelkrout, D. W. 1978. Component burnout hardness assurance safety margins and failure probability distribution models. *IEEE Transactions on Nuclear Science* NS-25(6):1508-1516. December.
- Egelkrout, D. W. 1979. Component burnout characterization methods. *IEEE Transactions on Nuclear Science* NS-26(6):4953-4958. December.
- Ericson, D. M., Jr., D. F. Strawe, S. J. Sandberg, V. K. Jones, G. D. Rensner, R. W. Shoup, R. J. Hanson, and C. B. Williams. 1983a. Interaction of Electromagnetic Pulse with Commercial Nuclear Power Plant Systems. Executive Summary. Washington: U.S. Nuclear Regulatory Commission (NUREG/CR-3069 SAND82-2738/1 Vol. 1). February.
- Ericson, D. M., Jr., D. F. Strawe, S. J. Sandberg, V. K. Jones, G. D. Rensner, R. W. Shoup, R. J. Hanson, and C. B. Williams. 1983b. Interaction of Electromagnetic Pulse with Commercial Nuclear Power Plant Systems. Main Report. Washington: U.S. Nuclear Regulatory Commission (NUREG/CR-3069 SAND82-2738/2 Vol. 2). February.
- Hart, W. C., J. H. Darrah, M. B. Sullivan, and R. W. Winn. 1981a. Team B Study Effort. Volume I of IV. *Precis*. Kirtland Air Force Base, New Mexico: Air Force Weapons Laboratory (AFWL-TR-80-36 Vol. I). August.
- Hart, W. C., J. H. Darrah, M. B. Sullivan, and R. W. Winn. 1981b. Team B Study Effort. Volume II of IV. *Technical Report*. Kirtland Air Force Base, New Mexico: Air Force Weapons Laboratory (AFWL-TR-80-36 Vol II). August.
- Hart, W. C., J. H. Darrah, M. B. Sullivan, and R. W. Winn. 1981c. Team B Study Effort. Volume III of IV. *Appendixes A-E*. Kirtland Air Force Base, New Mexico: Air Force Weapons Laboratory (AFWL-TR-80-36 Vol. III). August.
- Jeffreys, H. 1961. *Theory of Probability*. 3rd ed. Oxford: Clarendon.

- Jenkins, C. R. and D. L. Durgin. 1975. EMP susceptibility of integrated circuits. IEEE Transactions on Nuclear Science NS-22(6):2494-2499. December.
- Jenkins, C. R. and D. L. Durgin. 1977. An evaluation of IC EMP failure statistics. IEEE Transactions on Nuclear Science NS-24(6):2361-2364. December.
- Kahneman, D., P. Slovic, and A. Tversky, eds. 1982. Judgment under Uncertainty: Heuristics and Biases. New York: Cambridge University Press.
- Karzas, W. J. and R. Latter. 1965. Detection of the electromagnetic radiation from nuclear explosions in space. Physical Review 137(5B):B1369-B1378. March 8.
- Lindley, D. V. 1965. Probability and Statistics. Vol. 1, Probability; Vol. 2, Inference. New York: Cambridge University Press.
- Locasso, J. V. 1982. EMP Variations Study. Volume I--Analysis Results. Anaheim, California: Rockwell International Corporation (DNA-TR-82-24-V1). August 28.
- Longmire, C. L. 1964. Close-in EM Effects, Lectures 10 and 11. Los Alamos, New Mexico: Los Alamos Scientific Laboratory (LAMS 3073). Unpublished. April.
- Longmire, C. L. 1978. On the electromagnetic pulse produced by nuclear explosions. IEEE Transactions on Antennas and Propagation AP-26(1):3-13. January.
- Luce, R. D. and H. Raiffa. 1957. Games and Decisions. New York: John Wiley & Sons.
- Mindel, I. N. 1977. DNA EMP Awareness Course Notes. Third Edition. Washington: Defense Nuclear Agency (DNA 2772T). October.
- O'Donnell, H. B. and D. M. Tasca. 1978. Development of High Level Electrical Stress Failure Threshold & Prediction Model for Small Scale Junction Integrated Circuits. Philadelphia: General Electric Space Division (HDL-CR-78-138-1). September.
- Oetzel, G. N. and E. T. Pierce. 1969. The radio emissions from close lightning. Planetary Electrodynamics 1:543-571.

- Parhami, P. et al. 1982. A-7E EMP Vulnerability Assessment Report. Draft. Redondo Beach, California: Defense Systems Group, TRW, Inc. (36973-6112-SR-82). June.
- Parry, G. W. and P. W. Winter. 1981. Characterization and Evaluation of Uncertainty in Probabilistic Risk Analysis. Nuclear Safety 22(1):28-42. January-February.
- Pierce, D. G. 1982. Techniques for Bounding Component EMP Damage Thresholds. Bethesda, Maryland: Booz-Allen & Hamilton, Inc. August.
- Pierce, D. G. and R. M. Mason, Jr. Undated. A probabilistic estimator for bounding transistor emitter-base transient-induced failures. Albuquerque, New Mexico: Booz-Allen & Hamilton, Inc.
- Rustan, P. L., M. A. Uman, et al. 1980. Lightning source locations from VHF radiation data for a flash at Kennedy Space Center. Journal of Geophysical Research 85(C9):4893-4903.
- Savage, L. J. et al. 1962. The Foundations of Statistical Inference. New York: John Wiley & Sons.
- Shafer, G. 1976. A Mathematical Theory of Evidence. Princeton, New Jersey: Princeton University Press.
- Shoup, R. W., R. J. Hanson, and D. L. Durgin. 1981. Evaluation of EMP failure models for discrete semiconductor devices. IEEE Transactions on Nuclear Science NS-28(6):4328-4333 December 1981.
- Tasca, D. M. 1970. Pulse power failure modes in semiconductors. IEEE Transactions on Nuclear Science NS-17:364-372. December.
- Thomas, R. E. 1982. Current problems in aircraft EMP hardening. Colorado Springs, Colorado: Kaman Sciences Corporation.
- Tukey, J. W. 1977. Exploratory Data Analysis. Reading, Massachusetts: Addison-Wesley.
- Uman, M. A., W. H. Beasley, J. A. Tiller, Y. T. Lin, E. P. Krider, C. D. Weidmann, P. R. Krehbiel, M. Brook, A. A. Few, Jr., J. L. Bohannon, C. L. Lennon, H. A. Poehler, W. Jafferis, J. R. Gulick, and J. R. Nicholson. 1978. An unusual lightning flash at Kennedy Space Center. Science 201(4350):9-16.

- Uman, M. A., M. J. Master, and E. P. Krider. 1982. A comparison of lightning electromagnetic fields with the nuclear electromagnetic pulse in the frequency range  $10^4$ - $10^7$  Hz. IEEE Transactions on Electromagnetic Compatibility EMC-24(4):410-416. November.
- van Tilborg, A. M. and T. J. Jasinski. 1981. Circumvention against logic upset in ballistic missile defense multi-computer systems. IEEE Transactions on Nuclear Science NS-28(6):4384-4388. December.
- Williams, R. L. 1978. Semiconductor Device Damage Assessment for the INCA Program--A Probabilistic Approach. Adelphi, Maryland: Harry Diamond Laboratories (HDL-TR-1833). March.
- Wunsch, D. C. and R. R. Bell. 1968. Determination of threshold failure levels of semiconductor diodes and transistors due to pulse voltages. IEEE Transactions on Nuclear Science NS-16(6):244-259. December.

## APPENDIX A

### STATEMENT OF TASK

The scope of the committee's task is described in general terms in the contract between the Defense Nuclear Agency and the National Academy of Sciences. The relevant portions are excerpted below:

[The committee will] evaluate the relevant assessments, statistical models, and empirical predictions of electronic stress and failure resulting from nuclear explosions. One objective of the study will be to determine the validity of the statistical analyses, models, methodologies, and forecasting approaches in electromagnetic pulse (EMP) studies. Another is to determine the range of issues in the area of EMP phenomena and countermeasures and identify the major ones.

Based on its evaluation, the committee will prepare a report on the level of confidence it believes may be assigned to the methodologies currently employed in determination of the expected level of EMP effects and the degree of risk implied either by using the shielding or tailoring approaches for protection. It will make recommendations on research gaps, areas of uncertainty, and needs for further research. A final report will be produced at the end of the study.

To give additional clarity, structure, and specificity to the general task, at the first meeting of the committee the sponsor posed six questions for the committee to consider. Although the committee was not bound to develop exhaustive answers to all of the questions, they nevertheless were a useful guide to its work. The questions are listed below:

1. Based on the "probability of survival" (POS) approach to EMP hardness evaluation as it is presently defined and employed:
  - a. What would be the appropriate terms for expressing expectations of system hardness/vulnerability to EMP? (probability of survival/confidence? Go/no-go? A



- qualitative characterization? Other?) How do the prospects for characterization of EMP hardness relate to DOD decision analysis requirements?
- b. Is the POS approach sufficiently well defined/documented to allow an evaluation of its reliability or of the risks of reaching erroneous conclusions regarding system hardness?
  - c. What basis exists for the evaluation of reliability/risks and what reliability/risks should be attributed to the POS approach? Does the reliability/risk depend upon system features? If so, in what way?
  - d. What are the prospects for significant improvement of the POS hardness evaluation approach and what would be involved?
2. What procedures could be employed to reliably evaluate system hardness/vulnerability to upset?
  3. Based on the "tailored hardening" protection approach as presently defined and employed:
    - a. What are the appropriate terms for characterizing one's expectations regarding the attainment of system hardness and the retention of hardness throughout a system's life cycle following the introduction of tailored hardening?
    - b. Is the tailored hardening protection approach sufficiently well defined and documented to allow an evaluation of its effectiveness and of the risks of failure to attain and retain system hardness to EMP?
    - c. What basis exists for an evaluation of the effectiveness and the risks associated with the application of the tailored hardening protection approach? What effectiveness/risks should be attributed to it?
    - d. What are the prospects for significant improvement of the reliability/effectiveness of the tailored hardening protection approach? What would improvement entail?
  4. Based on the "integral shield with penetration controls" protection approach as presently defined and employed:
    - a. What are the appropriate terms for characterizing one's expectations regarding the attainment of system hardness and the retention of hardness throughout a system's life cycle following the introduction of integral shielding and penetration controls?
    - b. Is the integral shield with penetration control protection approach sufficiently well defined and documented to allow an evaluation of its effectiveness and of the risks of failure to attain and retain system hardness to EMP?

- c. What basis exists for an evaluation of the effectiveness and the risks associated with the application of the integral shield with penetration control protection approach? What effectiveness/risks should be attributed to it?
  - d. What are the prospects for significant improvement of the effectiveness and/or reliability of the integral shield with penetration control protection approach? What would improvement entail?
5. What can be said regarding the relative effectiveness/reliability of the tailored hardening and integral shielding with penetration control protection approaches in terms of prevention of upset? What can be said regarding the attainment and retention of hardness throughout a system's life cycle?
6. Electrical overstress damage and upset threshold distributions appear to constitute a critical issue relative to the validity of EMP hardness evaluation and protection approaches. We believe that investigation of the prospects for adequate knowledge regarding threshold distributions would constitute an efficient route to evaluation of the EMP hardness evaluation and protection approaches. Does the National Research Council agree? What should one conclude regarding the adequacy of the present understanding of thresholds and the prospects for acquiring adequate information to support confidence in hardness evaluation and system protection? What information requirements would have to be met?

APPENDIX B

PRESENTATIONS AT COMMITTEE MEETINGS

FEBRUARY 2-3, 1983

EDWARD E. CONRAD, Consultant  
Diversity of Viewpoints on EMP  
WILLIAM J. KARZAS, R&D Associates  
EMP Protection Approaches and Issues  
JERRY I. LUBELL, Mission Research Corporation  
EMP-Induced Upset  
ROBERT A. POLL, Jaycor  
Electrical Overstress Failure  
RICHARD R. SCHAEFER, Jaycor  
EMP Hardness Evaluation: Procedures and Issues  
GORDON K. SOPER, Defense Nuclear Agency  
Overview of EMP Problems and Issues

APRIL 1-2, 1983

ROBERT CARNEY, Boeing Aerospace Company  
Tailored Hardening Approach  
BRONIUS CIKOTAS, Defense Nuclear Agency  
EMP and Systems Hardening  
ERIK GRIMMELMANN, Bell Telephone Laboratories, Inc.  
Telephone Network Protection  
JAMES V. LOCASSO, Rockwell International Corporation  
Comments on Threshold Methodologies  
GENE E. MORGAN, Rockwell International Corporation  
EMP Shielding and Penetration Control Methodology  
A Sampling of System-Level Noise Data  
DAVID NEWMAN, Boeing Aerospace Company  
A Statistical Approach to C<sup>3</sup> Facility/Network Survivability  
Assessment  
NICHOLAS OSIFCHIN, Bell Telephone Laboratories, Inc.  
Bell Labs Involvement in EMP Programs

LOUIS H. RODDIS, Energy Research Advisory Board  
EMP and the Civil Economy  
FAUST ROSA, U.S. Nuclear Regulatory Commission  
EMP and Commercial Nuclear Power Plants

MAY 21, 1983

VINCENT K. JONES, Science and Engineering Associates, Inc.  
EMP Statistical Analyses

JUNE 1-2, 1983

AIR FORCE WEAPONS LABORATORY PERSONNEL  
Tours of EMP Simulation Facilities  
JOHN H. DARRAH, Space Command  
Internal Coupling Theory vs Experiment  
WILLIAM GORDON, Air Force Nuclear Criteria Group Secretariat  
The NCG/NCGS Story  
TONY M. JOHNSON, Air Force Weapons Laboratory  
Introduction to Air Force Weapons Laboratory  
ROBERT PARKER, Sandia National Laboratory  
Minuteman Missile Hardening Effort  
PAUL RYL (also known as CHRIS ASHLEY), Albuquerque, New Mexico  
Some Remarks on Assessing the EMP Reliability of Military Systems  
EDWARD F. VANCE, SRI International  
EMP Coupling to Long Lines

JUNE 3, 1983

DAVID R. ALEXANDER, Mission Research Corporation  
Overview of the Component Statistical Characterization Program  
EDWARD W. ENLOW, BDM Corporation  
Review of Testing, Data Storage, and Retrieval Procedures  
RICHARD A. HAYS, Air Force Weapons Laboratory  
The Component Statistical Characterization Program

AUGUST 9-10, 1983

EDWARD BEDROSIAN, Rand Corporation  
High-Altitude Electromagnetic Pulse--System-Relevant Issues  
and Recommendations  
HRIAR S. CABAYAN, Lawrence Livermore National Laboratory  
High-Altitude EMP (HEMP) Effects Studies Program Plan

LENNART MARIN, Dikewood Corporation  
EMP Tests on E-3 Aircraft  
RICHARD W. MENSING, Lawrence Livermore National Laboratory  
HEMP Vulnerability Assessment Methodology  
STEPHEN M. YOUNGER, Lawrence Livermore National Laboratory  
High-Altitude EMP Environment Codes

SEPTEMBER 30-OCTOBER 1, 1983

LEW ALLEN, JR., Jet Propulsion Laboratory  
Welcome to Jet Propulsion Laboratory  
ALAN M. CHODOROW, Mission Research Corporation  
EMP Hardening and Validation for Ground Based C<sup>3</sup> Facilities  
CONRAD L. LONGMIRE, Mission Research Corporation  
High-Altitude EMP Generation and Coupling--Variability  
and Effect on Vulnerability Assessments  
JAMES R. VAN ZANDT, MITRE Corporation  
EMP Protection of the E-4B

## APPENDIX C

### ELECTROMAGNETIC PULSE COUPLING PHENOMENA

Electromagnetic (EM) coupling of an external field, such as an electromagnetic pulse (EMP), to circuits and circuit elements inside an enclosed system takes place through intentional penetrations such as antennas and waveguides. In addition there usually are present many inadvertent EM coupling paths through elements such as cables, apertures, and grounding loops. While designed to handle the normal signal and noise background adequately, a system subjected to EMP may be caused to malfunction by spurious signals introduced through these penetrations and inadvertent coupling paths. Analyzing and predicting inadvertent coupling for the purpose of assessing and protecting a complex system has historically been and still is a difficult and challenging task.

#### ANALYTICAL APPROACH

While in principle an arbitrarily accurate analysis of the EM coupling can be derived by solving the Maxwell equations in the context of a boundary-value problem, in reality even for a relatively simple system a classical deterministic approach often demands more effort and resources than are available. To keep the mathematics tractable, judicious use of approximations and engineering judgments is inevitably required. Even so, the effort presently needed to obtain approximate deterministic predictions for EM coupling to complicated systems is still substantial (Baum, 1976).

As in many complicated problems attempts are made to simplify the analysis by considering small subproblems that can be treated independently (Tesche, 1978). The total solution to the main problem is then looked upon as a combination of such solutions. In the area of EMP, one can divide the analysis of a particular system into the following subareas:

1. Study of the production of EMP (EMP phenomenology).
2. Propagation of EMP.
3. Interaction of EMP with the exterior of the system (external interaction).

4. Coupling, propagation, and penetration of energy within the system (internal interaction).
5. Transient analysis of driven circuits within the system.
6. Overall system assessment.

This appendix is concerned mainly with points 3 and 4.

In many instances, the analysis of each subproblem is unrelated to the others, except of course for the excitation of one subproblem by another. In some cases, however, there may be more complex interactions between one subproblem and another. For example, if an aperture becomes too large, the interaction between the interior and exterior boundary value problems becomes such that they must be examined together. In general the decoupled deterministic method of analysis is reasonably accurate.

#### EXTERNAL INTERACTION

Macroscopic systems such as aircraft, satellites, and missiles generally have a complete or nearly complete metallic shell covering that serves as a shield from electromagnetic fields. The modes of field penetration are, for example: (1) the propagation through windows and holes in the metal covering, through joints in the metal skin, through cracks around access doors, and through exhaust ports; (2) the direct excitation of electrical cabling that is run outside the metallic covering over a portion of the surface and then run inside to some internal component; and (3) the direct excitation of system antennas (Taylor, 1978). For the foregoing examples the amount of current or voltage induced in a system element at a given frequency is directly related to the external electric and/or magnetic field, provided no nonlinear responses are excited. Thus the system elements are reasonably well decoupled from the EMP, and the deterministic method of analysis should yield accurate results.

The EMP coupling to an electric system inside a structure such as a building may not be so easily analyzed, since it may not be assumed that the system is protected by an exterior electromagnetic shield. However, certain buildings do possess a reinforcing-bar network that may act as a partial screen to electromagnetic fields. Unfortunately this screen is usually not sufficient to make the external fields independent of the interior system. What this means in terms of analysis is that the response of an interior component must be determined by considering the interaction of the total system as a whole rather than as separable into external and internal regions.

If the electrical system under consideration is shielded by a metal covering, then the electric and magnetic fields on the external surface are essentially given by the surface current density (sources of magnetic field) and surface charge density (sources of electric field) that would exist if the metal covering were a perfect

conductor. These are obtained by solving a system of partial differential equations (Maxwell's equations) or by solving the equivalent vector wave equations. In general, exact analytical solutions have limited application because of the complex geometry of typical structures.

Approximate analytical solutions have a broader range of application than exact solutions. In the low-frequency regime (wavelength greater than characteristic dimensions of the structure) the quasistatic approximation is quite useful (Taylor, 1973; Tesche, 1971; Liu et al., 1975). At high frequencies the physical-optics approximation yields good results (Lentz et al., 1972). This technique is particularly advantageous because it can be applied to any geometrical configuration without difficulty. A more accurate high-frequency approximation is obtained by using the geometrical theory of diffraction (Lentz et al., 1972; Tsai et al., 1972).

All the aforementioned techniques are limited to simple geometries by practical considerations. Thus modeling techniques are required for treating realistic geometrical configurations. For example, a model for a missile might be a body of revolution or a right circular cylinder. A rectangular parallelepiped or even a sphere might be used to model a metal building.

For geometrically simple structures the existing theoretical models yield sufficiently accurate results in predicting the external coupling to the EMP. For the more complex structures, such as aircraft, the theoretical model results may differ as much as 6 decibels (dB) from the measured skin currents and charge densities. Perhaps more accurate results could be obtained by using a fine three-dimensional wire-mesh model or by solving a three-dimensional integral equation for the surface current density.

The coupling of EMP to power transmission lines has been analyzed (Scharfman et al., 1978) using a low frequency version of Sunde's theory (Sunde, 1949). The model takes into account the effects of soil conductivity, polarization, line height, EMP pulse shape, and direction of arrival. Experimental work has shown the model to be accurate enough that more complex analytical techniques are not required. Effects of transformers and lightning arresters have also been analyzed. Coupling to telephone lines has been successfully analyzed in similar ways.

The general problem of EMP coupling through cable shields is fairly well understood (Casey and Vance, 1978). The coupling mechanisms involved are known, and in many specific cases (for example, small holes in the shield) the effects of coupling on the internally propagating signals are amenable to exact analytic determination. Specific features of the braided-shield coaxial cable have been studied: these include the anisotropic conductivity of the braid, apertures in the braid, and effects of the dielectric jacket.

EMP coupling to buried cables and other buried penetrations, such as drain, sewer pipes, and power leads to outside lights, has also



been analytically modeled. Scale model tests have been conducted. Problems presented by these types of penetrations are generally much smaller than those previously discussed.

The direct excitation of system antennas by EMP has been studied for both in-band and out-of-band response. These studies have included various types of airborne and grounded antennas, connecting transmission lines (coaxial and wave-guide) and antenna towers. Analytical techniques in these areas are well developed and their accuracy is very good.

#### INTERNAL INTERACTION

Much effort has been expended in trying to understand EMP phenomenology and propagation. A similar statement can be made about the external interaction and circuit areas. Although some effort has also been spent in developing the sophistication of the analytical tools in the internal interaction area (Tesche, 1978), it is generally agreed that the highest uncertainty exists in this area (Baum, 1974; Air Force Weapons Laboratory, 1972).

Often the terms "interaction" and "coupling" are used synonymously. There is, however, a substantial difference between internal coupling and internal interaction, both of which will be discussed below. Note that this distinction will hold for both internal as well as external problems.

The area of internal interaction begins at the skin of the system (aircraft, for example) and treats the radiation and propagation within the confines of the system. Thus it is presumed that the exterior interaction problem, as well as the penetration problem through the aircraft skin, has already been solved. Quantities of interest to be determined in an internal interaction calculation are the transfer functions from specified input ports to the critical electronic components within the system.

Consider a simplified internal interaction problem of a cable located inside a perfectly conducting shield having an aperture. It is assumed that the external problem has been solved, and sufficient information is available to determine the aperture field distributions. The steps in carrying out the internal interaction analysis are as follows:

1. With the solution of the exterior problem and knowledge of the equivalent sources in the aperture(s) that radiate into the interior region of the shield, compute the fields exciting the cable. This procedure is referred to as determining the "coupling" of the EMP energy to the cable and results in a knowledge of the local voltage and current sources exciting the cable.
2. Knowing these local cable sources, determine how they excite currents throughout the cable. This calculation, which also

gives the distribution of charges on the cable as its most important result, is called the "internal propagation" calculation. The calculation usually involves the use of the transfer-function concept, which will be discussed later.

3. With a knowledge of the charge distribution on the cable, determine how the fields penetrate through the cable shield, thereby exciting additional wires within the cable sheath. Such a "penetration" problem thus serves as a starting point for another internal interaction calculation performed in a smaller, better shielded region inside the cable.

Thus the internal coupling problem is a subset of the interaction problem and involves only the determination of local sources—not the solution of the propagation and penetration problems.

Following the notion of noninteraction between subproblems, the usual approach for treating the internal interaction problem is to define transfer functions that relate the frequency-domain voltages or currents at the inputs to the various circuits to the excitations of the interior regions of the system. These excitations, found as outputs from the external interaction problem, are usually the equivalent aperture electric and magnetic dipole moments caused by the fields passing through apertures or similar breaks in the shielded enclosure of the system. Considering a system with  $n$  ports of entry, it is possible to define, for each port, a pair of excitation terms given by  $\vec{P}_i(\omega)$  and  $\vec{M}_i(\omega)$ , which are the equivalent complex electric or magnetic dipole moments of the  $i$ th port of entry as functions of angular frequency,  $\omega$ . In the most general type of aperture both terms will exist, but there may be special cases where either one or the other type of dipole moment is negligible. Note that these individual dipole moments are themselves vector quantities.

The propagation of energy from these input ports to the various internal circuits occurs principally via transmission lines, although transmission line-like structures, such as hydraulic lines, can also guide energy within the confines of a large system. The response at a particular circuit with the system, let us say at the pin of a connector, can be evaluated if the open circuit voltage  $V_{OC}(\omega)$  and the impedances of the circuit and the feeding transmission line network are known.

The relationship between the open circuit voltage of a particular pin and the external excitation is given generally by

$$V_{OC}(\omega) = \sum_{i=1}^n \vec{T}_{E_i}(\omega) \cdot \vec{P}_i(\omega) + \vec{T}_{M_i}(\omega) \cdot \vec{M}_i(\omega), \quad (1)$$

where  $\vec{T}_{E_i}$  and  $\vec{T}_{M_i}$  are complex vector transfer functions that relate the excitation at the  $i$ th aperture to the voltage at the terminals under consideration. These transfer functions contain results of both the internal coupling and internal propagation analyses. The basic

problem in the internal interaction area, therefore, is to define accurately the elements of the transfer-function vectors in (1).

At present, there exist many difficulties in defining the elements of the parameters in (1). These difficulties stem from not having sufficient theoretical or numerical analytical methods to obtain parameters for the various coupling, propagation, and penetration models. Additionally, the possible inapplicability of some of the models may oversimplify the problem.

Because transmission line propagation is the most important mechanism for guiding EMP energy within the internal regions of a system, the determination of the transfer functions  $\vec{T}_{E_i}$  and  $\vec{T}_{M_i}$  is often accomplished using conventional transmission line analysis procedures. The geometry of the internal region is simplified in the vicinity of the transmission line; and, in most circumstances, a complex multiwire transmission line is modeled as a single wire transmission line (Carter and Curtis, 1974).

In some instances, where a uniform transmission line model is not applicable because of rapid variations of the transmission line geometry, the use of the lumped parameter model (LPM) (Air Force Weapons Laboratory, 1972) of the transmission line is possible. This approach, however, requires much computer storage and is not particularly useful for the analysis of large transmission line networks.

The use of general multiconductor transmission line analysis for internal interaction problems has been discussed by some investigators (Frankel, 1974; Paul, 1974) for a single section of a multiconductor transmission line model, including branching and closed loops. With this more detailed approach, the transfer functions of (1) can be evaluated more accurately, thereby providing a more accurate solution to the entire EMP interaction problem.

The analysis of EMP internal coupling to critical electronic components and subsystems is complicated by the presence of many seemingly random parameters, such as the relative positions of bunched cables near points of entry and the random positions of conductors in N-wire lines. These random parameters make the deterministic solution for EMP-induced excitations at particular load points discussed above very difficult. One can, of course, choose to analyze a single deterministic "average model" of the system in the hope that the excitations obtained will indicate expected excitations on any of several randomly different actual systems. If the random parameters strongly affect the coupling to certain critical system points, the actual excitations may differ vastly from the deterministic model predictions. A statistical analysis could then be performed to obtain a valid range of expected excitations.

A basic method for the statistical analysis of load excitations on an unshielded N-wire random cable illuminated by an incident monochromatic field has been developed. The technique utilizes the concepts of time-harmonic electromagnetic field reciprocity and

statistical representation of an ensemble by a subset. Although restricted to a limited class of structures (for example, unshielded, unbranched, N-wire cables), the method should be extendable to shielded and branched cables as well. In addition, it may be possible to conduct a direct time-domain analysis via Welch's reciprocity theorem (Welch, 1960).

#### COMPUTATION CODES

Numerous computer codes are available for analysis of EMP interaction and coupling problems (Bevensee et al., 1978). Most of the codes are based on integral realizations of Maxwell's equations and moment method solution schemes (Harrington, 1968). These methods without exception require spatial discretization, frequency or temporal discretization, and computer-aided solutions of a large number of coupled equations. As a result, sampling restrictions and computer speed and storage requirements do not vary significantly from one code to another. In addition, accuracy and field anomaly considerations apply generally. Types of codes include the following:

1. Thin-wire frequency- and time-domain codes applicable to antenna responses, bulk current predictions, and wire grid responses.
2. Surface codes including ones for bodies of revolution in the resonance regime, arbitrary surface codes, and hybrid codes.
3. General theory of diffraction codes for computing surface currents in the EMP spectral range.
4. Aperture codes.
5. Shielded cable codes.

Unfortunately, there exists no code that is applicable to all EMP coupling problems, so for many applications it is necessary to modify an existing code or write a new one. Recent trends in code development will alleviate part of this problem. There are codes under development that will eventually result in centrally maintained, general purpose EM codes applicable to a wide class of EMP problems. However many problem areas will persist. Physical modeling, error estimation, computer storage and timing requirements, and non-linear considerations are the most prevalent ones.

#### STATUS

To summarize briefly, EMP coupling is well understood and accurately modeled for such simple cases as antennas, single cables, and simple geometrical shields. However, for complex cases, such as large ground facilities and aircraft having multiple critical systems and extensive

interconnecting cabling, existing modeling and analysis technology is not sufficient. Predicted voltages and measured voltages often differ by amounts ranging up to 20 dB either way. These uncertainties increase the difficulties of estimating vulnerability to EMP effects. Thus testing, using threat-level EMP simulators, is currently required for the entire facility or aircraft, where possible.

## REFERENCES FOR APPENDIX C

- Air Force Weapons Laboratory. 1972. Electromagnetic Pulse Handbook for Missiles and Aircraft in Flight. EMP Interaction Notes 1-1. Albuquerque, New Mexico (AFWL-TR-73-68). September.
- Baum, C. E. 1974. How to think about EMP interaction. Proceedings 1974 Spring FULMEN Meeting. Albuquerque, New Mexico: Air Force Weapons Laboratory. April.
- Baum, C. E., ed. 1976. EMP Interaction Notes. Albuquerque, New Mexico: Air Force Weapons Laboratory.
- Bevensee, R. M. et al. 1978. Computer codes for EMP interaction and coupling. IEEE Transactions on Electromagnetic Compatibility EMC-20(1):156-164. February.
- Carter, J. M. and W. L. Curtis. 1974. Common Mode Model Development for Complex Cable Systems. Seattle, Washington: Boeing Company (AFWL TR-74-60).
- Casey, F. K. and E. F. Vance. 1978. EMP coupling through cable shields. IEEE Transactions on Electromagnetic Compatibility EMC-20(1):100-106. February.
- Frankel, S. 1974. Cable and Multiconductor Transmission Line Analysis. Adelphi, Maryland: Harry Diamond Laboratories (HDL-TR-091-1). June.
- Harrington, R. F. 1968. Field Computation by Moment Methods. New York: MacMillan.
- Lentz, R.R., P. H. Pathak, and W. D. Burnside. 1972. Surface current and surface charge density induced on aircraft models. Interaction Notes No. 117. Columbus, Ohio: Department of Electrical Engineering, Ohio State University. June. Also see the paper in this issue by Hwang, Peters, and Burnside.

- Liu, T. K., S. H. Lee, and L. Marin. 1975. Broadband response of deliberate aircraft antennas, Part I. Interaction Notes No. 228. Columbus, Ohio: Department of Electrical Engineering, Ohio State University. May.
- Paul, C. R. 1974. Efficient numerical computation of the frequency response of cables illuminated by an electromagnetic field. IEEE Transactions on Microwave Theory and Techniques MTT-22:454-457. April.
- Scharfman, W. E., E. F. Vance, and K. A. Graf. 1978. EMP coupling to power lines. IEEE Transactions on Electromagnetic Compatibility EMC-20(1):129-235. February.
- Sunde, E. D. 1949. Earth Conduction Effects in Transmission Systems. New York: D. Van Nostrand.
- Taylor, C. D. 1973. On the circumferential current and charge distributions of circular cylinders near a ground plane. Interaction Notes No. 138. Columbus, Ohio: Department of Electrical Engineering, Ohio State University. March.
- Taylor, C. D. 1978. External interaction of nuclear EMP with aircraft and missiles. IEEE Transactions on Electromagnetic Compatibility EMC-20(1):64-76. February.
- Tesche, F. M. 1971. Charge distribution on a two-dimensional airfoil. Interaction Notes No. 75. Columbus, Ohio: Department of Electrical Engineering, Ohio State University. May.
- Tesche, F. M. 1978. Topological concepts for internal EMP interaction. IEEE Transactions on Electromagnetic Compatibility EMC-20(1):60-64. February.
- Tsai, L. L., D. R. Wilton, M. G. Harrison, and E. H. Wright. 1972. A comparison of geometrical theory of diffraction and integral equation formulation for analysis of reflector antennas. IEEE Transactions on Antennas and Propagation AP-20:705-712. November.
- Welch, W. J. 1960. Reciprocity theorems for electromagnetic fields whose time dependence is arbitrary. IRE Transactions on Antennas and Propagation AP-8:68-73.

## APPENDIX D

### CLASSES OF ACCEPTABLE PERFORMANCE FOR RESISTANCE TO ELECTROMAGNETIC PULSE

This appendix addresses the issue of damage and upset responses of systems and subsystems that may have varying degrees of criticality in performance of a mission and varying degrees of tolerance to temporary outage.

#### DAMAGE VERSUS UPSET

Several times in the course of presentations to the committee the subject of damage versus upset was raised. Several briefers pointed out the increased difficulty in protecting against upset because of its lower thresholds relative to damage. It is important to understand what one means by upset. Two categories of upset may occur, which should be considered separately.

The first category of upset involves precipitous actions (for example, releasing a weapon) caused by erroneous states induced by the stress of electromagnetic pulse (EMP) in logic or other electronic or electromechanical elements of a system or subsystem. This category can be characterized by the instantaneous or nearly instantaneous consequences of temporary EMP disturbances. After the EMP has passed, the disturbed electronic or electromechanical elements are assumed to resume completely normal operation; but some significant undesirable action has occurred because of the disturbance caused during the EMP event.

The second category of upset involves the disturbance of stored states in an electronic or other memory, such as random access memory, hardwired logic, tape, and disc. This disturbance results in erroneous information stored in that memory after an EMP event. Presumably, this erroneous information results in undesirable actions at a future time, such as loss of navigational capability or failure of a system containing the memory to respond normally when activated.

The difference between these two types of upset is important for two reasons. First, devices that store information are relatively easy to shield against EMP because they can be physically confined to a small volume of a large system and because they can be carefully

shielded with controlled shield penetrations (for example, fiber optic input-output). Further, it should be relatively easy to standardize on a small number of approved memory technologies for critical applications. Secondly, those mission-critical system elements (not necessarily containing memory) that, if disturbed, will lead to instantaneous or nearly instantaneous disaster should be identified and protected more carefully than less critical system elements.

These arguments, initially concerned with the subject of damage versus upset, lead to the following thoughts on classes of acceptable response and their associated protection.

#### CLASSES OF ACCEPTABLE ELECTROMAGNETIC PULSE RESPONSE

Since there seems to be a hierarchy of mission-affecting elements in any system (where the most mission-critical elements tend to be fewer in number), there also appears to be some merit in establishing a hierarchy of acceptable EMP responses. The most demanding elements are those whose disturbance causes immediate catastrophe because actions are precipitated which are themselves catastrophic. Examples might include weapon actuators or the terrain-following navigation system of low-flying, high-speed aircraft. Subsystems in this category might be individually identified and hardened (by design or overbuilt protection) to resist EMP at all times--even during the EMP event. Less critical elements might be allowed to assume malfunctioning states during an EMP event, but be required to return to working condition within a specified recovery interval (say, 1 millisecond) without manual intervention. Still less critical elements might be allowed to assume malfunctioning states requiring manual reset, provided that they can be quickly diagnosed as malfunctioning. Finally, some noncritical elements might be allowed to fail by reason of damage, thus requiring physical repair or replacement.

The reasoning behind this proposed set of EMP response classes is the presumption that the most critical mission elements are fewer in number and easier to protect. For example, the most susceptible entities in an airplane might be long metallic conductors carrying power. However, critical electronic entities on the airplane should be relatively easy to isolate from the main power buses and should have enough capacitive storage to "ride out" an EMP disturbance, even if the power buses themselves were briefly out of service (for example, shorted by protection devices). Thus the power buses would merit a different class of protection than the subsystems they power.

The value of this approach to classes of EMP protection is the avoidance of a possibly unnecessary brute force approach, wherein all system elements are treated equally at the cost of less protection for critical elements and an overpessimistic assessment of the feasibility of tailored hardening approaches.



## APPENDIX E

### STATISTICAL ISSUES ARISING IN THE ASSESSMENT OF THE EC-135 AIRCRAFT

This appendix comments on statistical procedures used in the electromagnetic pulse (EMP) assessment of the EC-135 aircraft. In particular, this material is based to a considerable degree on a reading of a report by Ashley and Locasso (1977), which discusses the algorithm used to determine the reliability or confidence of the EMP margin of the EC-135. Related reports on assessment of the EC-135 were also examined. Discussion with Ashley (also known as Paul Ryl) and Locasso was also helpful.

#### BASIC SETUP FOR EC-135 ASSESSMENT

At the time the EC-135 assessment was carried out, in the 1970s, the EC-135 fleet was planned to contain 12 individual aircraft. These aircraft were not all the same; that is, they were not all constructed to an identical design. In fact, some were designated EC-135C and others, EC-135G.

One aircraft copy from the above collection was selected for assessment. It is not clear how the initial selection was made; but presumably every attempt was made to obtain a representative, if not a "random", example.

The entire aircraft was tested at an EMP test bed under simulated conditions; in particular, pulse values were much lower than actual real-life values are believed to be. The aircraft was tested under various orientations, but an attempt was made to pick worst-case situations.

Apparently the aircraft selected was viewed as a collection of 28 potentially mission-critical (sub)systems for EMP vulnerability assessment purposes. (Henceforth the term "sub" is dropped while discussing the individual aircraft.) Each system was in turn made up of a varying number of boxes, each of which in turn consisted of a number of components--for example, semiconductors--wired together into functional circuits. Boxes were interconnected by cables containing a number of wires, and cables joined boxes by means of plugs.

Individual semiconductors were joined by wires, which entered their respective boxes through cables and plugs.

#### THRESHOLDS AND STRESSES

EMP is a threat because it may induce large currents on wires leading to components. The result may be failure of the aircraft to function: either temporary failure, by "upset", or permanent failure, by "burnout". Resistance to failure is termed hardness.

#### Thresholds

Component burnout (or, more generally, failure) occurs if an applied current, reaching the component through a wire, exceeds a given value called a threshold current. This statement is simplistic, but it is correct enough for the present purpose. The relationships relating to semiconductor geometry and to other factors besides electric current are wrapped up in the constants in Wunsch's Law (Wunsch and Bell, 1968) or modifications thereto. Wunsch's Law states that the threshold power for failure is inversely proportional to the square root of pulse duration.

It is convenient to think of the threshold,  $t$ , of an individual component in logarithmic terms,

$$t = 20 \log_{10}(I_t/I_r),$$

where  $I_t$  is the threshold current and  $I_r$  is a reference current. Thresholds vary between copies of "the same" components. Thresholds are actually measured experimentally, by destructive step-stress tests (Appendix F). It turns out that the distribution of logarithmic thresholds is often taken to be "nearly normal/Gaussian" as a first-order approximation. In what follows, the term threshold will mean the quantity  $t$ , as above. Work by Alexander and Enlow (1981) seems to show the existence of some semiconductor "weak sisters," evidenced by threshold distribution skewness to the left or, equivalently, a relatively long tail towards small values, for some tests. Once recognized, this weakness may perhaps be curable; hence it may not occur in the future.

In statistical terms, think of the threshold,  $t$ , of a given device as a realization of a random variable  $T$ , with distribution  $F_T(x)$ --the probability that  $T$  is less than or equal to  $x$ .  $F_T(x)$  is possibly normal, or nearly so. Think of different copies of the same device as having thresholds independently selected from a population of devices described by  $F_T(x)$ --at least as a first approximation.

Characterization of all variability between individual semiconductor component copies as independent and random is conceptually simplistic. There can perhaps be different variability characteristics (different distributions) for nominally the same component because of between-batch dissimilarities in manufacture or shelf life. Thus the actual components in place on the test aircraft may not be a random sample from the same devices found on shelves or delivered by manufacturers.

Note that the above discussion emphasizes the natural variability of thresholds. It does not refer to errors of estimates of thresholds.

### Stresses

This appendix uses the term stress to mean the current delivered to a box, or component thereof, by EMP. The stress applied to a component comes through a wire within a cable into a box and then to a component.

The magnitude of stress, again logarithmically, is often represented as

$$s = 20 \log_{10} (I_S/I_R),$$

where  $I_S$  is the stress current.

One may, in some cases, think of  $s$  as being an instance of a random variable,  $S$ . Such may be especially relevant in an operational environment, where the stress experienced by the aircraft varies with orientation, altitude, nuclear burst height, and other parameters. In the context of an experimental assessment, there is an attempt to condition on these experimental variables. This conditioning removes one source of stress-associated variability.

However, assessment is conducted under less-than-operational stress considerations; and it is necessary to "extrapolate to threat criteria levels," using a model. Two methods of such extrapolation were apparently used for the EC-135 aircraft. Such methods are likely to have systematic elements (biases) that are unknown. Accordingly, use of two methods is a sign of care. Note too that, given the external stress, it is necessary to consider variations of wire currents attributed to point of entry. Furthermore, it has been necessary to estimate or predict wire currents from bulk cable currents. The methods for doing so are acknowledged to have certain errors that must be assessed from measurements (Appendix C). Notice again that such a prediction is susceptible to systematic, bias-like errors as well as "random" errors. It is the latter that are handled best by probabilistic and statistical tools. Assessment of the former seems to be situation-specific.

It was apparently also the practice to equate the vulnerability of a box with that of the device closest to the terminals of the box. That is, one assumed that all but one crucial microelectronic device

have no vulnerability. This assumption is a simplifying one that is not conservative, because remote devices could, in principle, fail. A more sophisticated approach might utilize methods such as fault tree analysis, but it is likely that prediction principles for box-level failure are not well understood. Again bias, as well as random errors, may well be present in box-level assessment of failure.

In summary, errors in thresholds and stress may well be both "systematic" and "random." These errors propagate into the estimate of safety margin (Appendix F) and so may affect assessments of hardness and, eventually, confidence statements concerning probability of survival.

#### GENERAL COMMENTS ON THE ASSESSMENT

The authors of the EC-135 assessment reports, both classified and unclassified, wisely devote considerable attention to expressing the uncertainties inherent in their margin determinations. Here are some comments on what has been done.

Firstly, the language used to express these uncertainties is not entirely standard. Unfortunately, words have been used in EC-135 assessment reports that have somewhat different standard statistical meanings ("confidence") or that have standard meanings outside the area of statistical practice ("reliability") and yet are used in an error-characterization, statistical context in these reports and in supporting documents. In what follows an attempt will be made to clarify some of this ambiguity.

Secondly, the statistical practices used to quantify and combine "random" errors in the EC-135 assessment reports can very likely be improved and made somewhat less subject to criticism. Some of the information needed for improvements is based on statistical theory available at the time of the assessment; other information is not so based, or possibly it is not completely understood today.

#### Confidence

The notions of personal confidence and confidence limits are utilized several times in the EC-135 assessment reports. Unfortunately, from the point of view of principles, the term confidence is applied to an overall calculation that combines two distinct concepts of confidence.

#### Classical Concept

The first concept is the classical sampling-theory confidence ideas of Neyman; see Cramér (1946), Cox and Hinkley (1974) or many other standard sources. This approach assumes that an unknown parameter or

constant of interest is a fixed, unknown constant. Specifically, the true margin of an EC-135, or a system or box therein, has a specific unknown value at assessment time. Likewise, the variance of the total error made in estimating true margin is a fixed, unknown constant. Errors in the parameter estimates are instances of random variables.

When classical confidence limits are formed, for example after assessment data are analyzed, it is agreed that the resulting limits either cover (capture), or fail to cover, the unknown parameter. No probability statement is made about the particular limits resulting from the particular assessment data; no probabilistic statements are made about the value of the parameter of interest. Probabilistic statements are, instead, made concerning coverage properties of confidence limits constructed from other sets of data, actually or conceptually obtained, that are afflicted with the same error sources.

Classical confidence procedures may be criticized, but they are a standard expression of sampling uncertainty.

#### Probabilistic Concept

A different notion of confidence has been defined by Ashley and Locasso (1977) and used in the EC-135 assessment. This form differs from the above concept in assigning probabilities to the possible values of an unknown parameter. Quite specifically, the Ashley confidence assigns a probability density (at some point called a "confidence density function") to the unknown probability of success in a sequence of Bernoulli trials (coin flips with biased coin); the density obtained is conditional on the number of successes observed in a fixed number of trials. In the Ashley scheme, the confidence that the unknown probability of success exceeds, say, 0.90 is the integral of the above conditional density from 0.90 to 1.

Examination of the formula obtained for the above density reveals that it is entirely equivalent to a simple standard Bayesian formulation: if a uniform prior probability density is associated with unknown values of  $p$ --the probability of success--and the observations taken and a binomial likelihood calculated, the result is precisely what has long been called the posterior probability density of  $p$ . The uniform prior probability density is justified by Ashley, using words like "maximum ignorance assumption." That this approach is not acceptable is demonstrated easily by consideration of the fuel consumption of a population of automobiles, for which "maximum ignorance" might assume a uniform distribution in miles per gallon or, alternatively, in gallons per mile. If one is flat, the other is not!

Unfortunately, the above notion has also been called confidence, without distinguishing it from classical confidence. It is also claimed that "the analysis begins with intuitively acceptable statements about confidence and proceeds without recourse to devices such as Bayes' rule...." In fact, the concept is entirely equivalent

to a simple form of Bayes' rule (an equivalence that is not pointed out). One difficulty with standard Bayes approaches to statistics is specification of a suitable prior distribution. Assignment of a uniform prior probability density in the Bernoulli trials situation must somehow be justified. Arguments for such a prior probability density will not convince everyone, and they are in no way new.

Perhaps fortunately, calculations made using the above confidence result in numbers that are not very different from classical results of the type first described above. This effect is widely encountered in Bayesian analyses when so-called vague or diffuse prior distributions are used; the uniform distribution is a vague prior.

Bayesian concepts have an important role to play in statistical inference. It is troubling to find a simple version of such concepts repackaged and renamed. Such cannot lead to good communication of analytical results. It seems to represent a kind of insularity that inhibits rapid assimilation and application of promising new, not to mention appropriate classical, methods.

#### Reliability

The term reliability, as used in the EC-135 assessment reports, is not the conventional probability of successful operation of a component or system. According to the definition given in one such report it is the following:

The term, reliability, is used in this report to mean a lower bound on the probability that a margin is at least some specified value. That is, it is the reliability of a statement that the margin is at least a given value. This is not the same as the reliability of a component or system except in the special case in which the margin specified happens to be 0 decibels (dB).

-- Rockwell International Corporation (1978)

The idea is to quote a lower level for margin that is computable from data and that has a quantifiable, probabilistically expressed nature. The limits used appear similar to the tolerance limits of statistics, as studied by Shewhart (1939), Wilks (1941), and Wald and Wolfowitz (1946). There is some evidence that the authors of the EC-135 report realized, and made use of, this fact. Such lower limits were computed for each of the 28 (sub)systems in the EC-135; and they were used to rank those subsystems for hardness, that is, the degree to which margin seemed positive.

In a strict, classical, non-Bayes sense, there is no meaning to "a lower bound on the probability that a margin is at least some specified value," if one interprets this as a probability on the margin itself. "Probability" here refers to errors in the determination of the margin, the latter being viewed as an unknown constant.

If, as seems quite possible, achieved margin varies from system copy to copy and if measured margin exceeds some level, then the conditional probability that true margin itself exceeds a meaningful level can be calculated. However, it is necessary to have, or estimate, the equivalent of the distribution of actual margins and the conditional distribution of measured margin (or error in determining margin), given actual margin, in order to make the interesting Bayes' rule calculation. It has not appeared that such a calculation, with its necessary but expensive ingredients, has been attempted.

#### RELIABILITY AND CONFIDENCE IN THE EC-135 ASSESSMENT

The ideas of reliability and confidence are combined and applied to EC-135 assessment in an attempt to bound (sub)system margin from below. This step was deemed prudent because errors were acknowledged to occur at various stages of the assessment; and the latter were taken to be random--that is, suitably described as random variable realizations and not as biases. Units were always decibels.

#### Assessment Procedure

Here is the procedure apparently used (Ashley and Locasso, 1977, plus later explanation apparently furnished by Ashley), along with our comments. The step numbers used by the authors have been retained for ease of reference.

1. Seven (7) margin error sources were identified.
2. Consider each margin error source  $i$  ( $i = 1, 2, \dots, k$ ; here  $k = 7$  from step 1).
  - a. It was possible to obtain records of observed or estimated errors. (Note: Details for this step are unclear.)
  - b. Margin errors (dB) for source type  $i$  were compared to the Gaussian/normal distribution: apparently mean and variance were estimated and a chi-squared test performed; the Gaussian/normal model was accepted as true if the chi-squared statistic did not exceed a critical value.
    - (i). If the error source data "clearly passed" the above test, then the data were treated as if they were precisely Gaussian/normal in the following analysis. (Note: The only graphical assessment of the Gaussian/normal model was by histogram. More sensitive methods (with respect to tail behavior) would be plotting on arithmetic probability paper or Q-Q plots.)

Supposing the data passed the goodness-of-fit test, the ordinary sample standard deviation (subscript "o" for "ordinary"),

$$s_{oi} = \left( \frac{1}{n_i - 1} \sum_{j=1}^{n_i} (x_{ij} - \bar{x}_i)^2 \right)^{1/2},$$

of the data values  $x_{ij}$  ( $j = 1, 2, \dots, n_i$ ) was computed for the  $i$ th error source. This quantity was then adjusted upwards so as to give  $s_i$ , a number approximating the upper 90% point of the sampling distribution of the ordinary sample standard deviation, where

$$s_i = \left( \frac{\sum_{j=1}^{n_i} (x_{ij} - \bar{x}_i)^2}{\chi_{n_i-1}^2(1-C_i)} \right)^{1/2}.$$

Here  $C_i$  represents confidence level and

$\chi_{n_i-1}^2(1-C_i)$  is the  $(1-C_i) \cdot 100\%$  point of the chi-

squared distribution with  $n_i-1$  degrees of freedom. (Note: To be definite, suppose  $n_i = 31$  and  $C_i = 0.9$ ; then tables give for the multiplier of the ordinary sample standard the number  $(1/0.687)^{1/2} = 1.21$ . Even if the normal

approximation for the estimates of  $\sigma_i^2$  were used,

this answer is very nearly the same for this sample size.)

- (ii). If the goodness-of-fit test was not passed, a "fix" based on a Bayes-like calculation was utilized. (Note: This step is not easily understood, especially when seen in the context of the previous steps, which have quite a classical statistical flavor. In our subsequent comments on this assessment procedure, we ignore step (ii).)

- (iii). Compute  $\hat{V}_i = s_i^2$ .

3. Compute  $\hat{V} = \sum_{i=1}^k \hat{V}_i = \sum_{i=1}^k s_i^2$ .



4. Compute  $s = \hat{V}^{1/2}$ .
5. Assume  $k$  large enough to justify assumption that the sum of errors in bounding the true population variances  $\sigma_i^2$  by  $s_i^2$  is approximately normal. (Note: Passage of tests for normal optimistically suggests adequacy of the normal assumption, possibly unless the need for step (ii) is encountered and unless there exists an unfortunate dependence between errors. This latter possibility does not seem to have been addressed.)
6. Accept  $s = \hat{V}^{1/2}$  as upper bound on standard deviation  $\sigma$  for this total error distribution.
7. Compute a lower bound on the margin  $\hat{m}_R = \hat{m}_{0.5} - zs$ , where  $\hat{m}_{0.5}$  is the measured value of margin and  $z$  is taken from the normal probability tables. For example, for one-sided 95%,  $z = 1.645$ , for one-sided 90%,  $z = 1.28$ , and so forth.
8. Assign to  $\hat{m}_R$  the confidence  $\min(C_i)$ ; it is understood that if  $s_i$  is computed as indicated, with  $C_i = 0.9$ , and if the possibility (ii) is neglected or does not occur, then a confidence of 90% in the overall statement will be achieved.
9. Allowances must be made for mission-specific subsystem requirements when carrying out confidence calculations.

#### Comments

The procedure outlined above involves many steps. The final assertion is one of overall confidence in an error bound. It will be pointed out that at least one of the steps taken leads to literally incorrect results. It is not known what the actual overall "confidence" associated with the procedure is. This question could, however, be investigated by the Monte Carlo method under plausible assumptions. Such a step is always advisable.

#### Analysis of the Variance Estimation Procedure

Here is a simplified discussion of the procedure outlined above and, presumably, followed in EC-135 assessment.

Suppose there are  $k$  error sources, and assume errors are independently and normally distributed with variance of the  $i$ th source being  $\sigma_i^2$ . The object is to put a confidence limit above

$$\sigma^2 = \sum_{i=1}^k \sigma_i^2 \text{ with prescribed confidence level } \alpha \cdot 100\%.$$

The procedure described by Ashley and Locasso can be seen to be literally incorrect from the following special example. Take  $\sigma_i^2 = \sigma_1^2$ , that is, all variances equal; and also let  $n_i = n_1$  so all sample sizes are equal. Under this assumption the factor  $M$  multiplying the ordinary sample variance  $s_{i0}^2$  in order to generate an upper  $\alpha \cdot 100\%$  confidence bound on  $\sigma_i^2 = \sigma_1^2$  is always  $(n_1 - 1) / \chi_{n_1 - 1}^2(1 - \alpha) = M$ . Since the independent  $(n_1 - 1)s_{oi}^2 / \sigma_i^2$  are distributed as chi-squared, and since the sum of independent chi-squared distributions is also distributed as chi-squared, with degrees of freedom equal to the sum of the separate degrees of freedom, under the circumstances mentioned we have

$$(n_1 - 1)k(s_{o1}^2 + s_{o2}^2 + \dots + s_{ok}^2) / \sigma^2 \sim \chi_{(n_1 - 1)k}^2$$

where  $\sim$  means "is distributed as"--here as chi-squared with  $(n_1 - 1)k$  degrees of freedom. Note that  $\sigma^2 = k\sigma_1^2$  in this particular case. Consequently,

$$\frac{(n_1 - 1)k(s_{o1}^2 + \dots + s_{ok}^2)}{\chi_{(n_1 - 1)k}^2(1 - \alpha)} > \sigma^2$$

with exact confidence  $\alpha$  for one set of data (or with probability  $\alpha$  over many independent experiments). However, it is proposed by Ashley and Locasso to quote

$$M(s_{o1}^2 + \dots + s_{ok}^2) > \sigma^2$$

with confidence  $\alpha$ ; here  $M = (n_1 - 1) / \chi_{n_1 - 1}^2(1 - \alpha)$  as above. This multiple of  $(s_{o1}^2 + \dots + s_{ok}^2)$  does not give a confidence of  $\alpha \cdot 100\%$ , but something much higher. If, for instance,  $n_1 = 21$  and  $\alpha = 0.9$ , then  $M = 1.61$ . However, for this multiple of  $(s_{oi}^2 + \dots + s_{ok}^2)$ , and for  $n = 21$  and  $k = 7$ , a quick examination of chi-squared tables shows that confidence is at least at the 99.5% level. In this instance, the proper multiple of  $(s_{oi}^2 + \dots + s_{ok}^2)$  to attain 90% confidence is 1.18.

Although such conservatism seems laudable, it is not clear that its presence was recognized.

#### Other Approaches to the Variance Estimation

Of course similar calculations cannot in general be made exactly, but a number of approaches do exist for getting reasonable approximate confidence limits on  $\sigma^2$ . These include the following.

1. Large-sample normal approximation for standard error and approximate confidence limits Assume that  $\hat{\sigma}^2 = \hat{\sigma}_1^2 + \dots + \hat{\sigma}_k^2$  is approximately normal with mean  $\sigma^2$  and

$$\text{Var}[\hat{\sigma}^2] = \sum_{i=1}^k \frac{2\sigma_i^4}{n_i-1} \approx \sum_{i=1}^k \frac{2\hat{\sigma}_i^4}{n_i-1},$$

where  $\hat{\sigma}_i^2 = \sum_{j=1}^{n_i} (x_{ij} - \bar{x}_i)^2 / (n_i - 1)$ . The approximate variance of  $\hat{\sigma}^2$  is easy to compute, assumes the underlying observations are exactly normal, and should be useful at least for rough assessments, especially if  $n_i$  values are rather large (perhaps 25 or more); unfortunately they often are not so large. This procedure is, however, notoriously sensitive to the assumption that the underlying data are normally distributed; this difficulty already arises for the individual  $\hat{\sigma}_i^2$ . It is true that the cube root of the sample variance, when observations are normal, is close to the normal form. Use of this fact may improve the above approximation (details omitted.).

2. An approximation of the distribution of  $\sigma^2$  by a moment-fitted gamma (chi-squared) distribution This procedure was first proposed by H. Fairfield Smith, who thanked "Dr. R. A. Fisher" for the suggestion. Often associated with Satterthwaite (1946), the method has been used by many through the years for approximating nearly-chi-squared distributions, of which the above is an example. It has, for instance, been used in the Welch two-sample t-distribution approximation; see Brownlee (1965), pp. 300-301. For the present problems,

use of these results seems appropriate:  $\sum_{i=1}^k s_i^2$  is approximated by a  $\chi^2$  variable with mean  $\sum_{i=1}^k \sigma_i^2$  and degrees of freedom

$$n' = \left( \sum_{i=1}^k s_i^2 \right)^2 / \left( \sum_{i=1}^k (s_i^2)^2 / n_i \right).$$

In other words act as if

$$n' \sum_{i=1}^k s_i^2 / \sum_{i=1}^k \sigma_i^2 \sim \chi^2_{(n')},$$

from which approximate confidence limits are obtained. Preliminary Monte Carlo sampling studies suggest that this method works well provided the data are nearly normal and the true variances do not differ by factors of more than ten. Severe nonnormality of the underlying data may well call for modifications in this method.

3. An approximate distribution for  $\sigma^2$ , given  $\hat{\sigma}^2$ , using a large-deviation technique The result would be Bayesian confidence limits. This technique needs development before it can be adequately evaluated; it is not yet standard.

4. The jackknife Here it is probably best to put confidence limits on  $\ln \sigma^2$  or  $(\sigma^2)^{1/3}$  by jackknifing either

$$\ln \hat{\sigma}^2 = \ln(\hat{\sigma}_1^2 + \hat{\sigma}_2^2 + \dots + \hat{\sigma}_k^2)$$

or  $(\hat{\sigma}^2)^{1/3}$ .

See Mosteller and Tukey (1977) for details. Properties of the jackknife for setting approximate standard errors and confidence limits are supposed to be rather insensitive to non-normality; the quality of the results can be investigated by Monte Carlo sampling. The jackknife is perhaps twice as computer-intensive as approaches 1 and 2, above.

Note also that application of the linearization, or "delta," method to  $\ln \sigma^2$  is likely to be better behaved than estimate 1, above. At least, transformation of the logarithm back to  $\sigma^2$  certainly assures that confidence limits are positive!

**5. The bootstrap** Here one proceeds as follows from data  $x_{ij}$ ;  $i = 1, 2, \dots, k$ ;  $j = 1, 2, \dots, n_i$ . For each  $i$  separately, draw at random with replacement from original raw data values  $x_{ij}$  to obtain a bootstrap sample  $x_{ij}(b)$ ,  $j = 1, 2, \dots, n_i$ . Then compute  $\hat{\sigma}_i^2(b)$  and evaluate

$$\hat{\sigma}^2(b) = \sum_{i=1}^k \hat{\sigma}_i^2(b).$$

Now repeat; sampling with replacement from each group  $i = 1, 2, \dots, k$ . Obtain thus, say, 200 values of  $\hat{\sigma}^2(b)$ . Order the resulting values of  $\hat{\sigma}^2(b)$ ; the 90% value, that is, 20 down from the largest, approximates the upper 90% confidence limit for  $\sigma^2$ . This method is believed to be quite insensitive to underlying distributions. It may well eliminate worries represented by the introduction of step (ii). However, more work could be done on its performance in the present context, both by sampling and by analysis. Although the bootstrap seems appropriate here, it is much more computer-intensive than the jackknife; and its clear advantage for the present application has not yet been established. See Efron (1981) and Mallows and Tukey (1983) for details and commentary.

#### Analysis of Margin Uncertainty

This discussion is with reference to step 7 above. The margin quoted in the EC-135 study is actually an estimated conservative margin, or reliable margin. Let estimated margin be

$$\hat{m}_R = \hat{m}_{0.5} - zs \approx \hat{m}_{0.5} - z \hat{\sigma}.$$

It appears that if  $\hat{\sigma} = s$  is afflicted by errors from various sources, that is, is estimated with uncertainty, then so is  $\hat{m}_{0.5}$ .

Consequently it should be of interest to assess the uncertainty in  $\hat{m}_R$ . It has not been possible to determine just how errors affect  $\hat{m}_{0.5}$ , but perhaps it is reasonable that a quoted estimate is unbiased and that

$$\hat{m}_{0.5} = \underbrace{m_{0.5}}_{\text{true}} + \underbrace{\bar{x}_1 + \bar{x}_2 + \dots + \bar{x}_k}_{\text{error averages}}$$

where the error averages from the  $k = 7$  sources (here) have zero mean (an optimistic assumption signifying no bias), and are independently sampled from their respective near-normal distributions with variances  $\sigma_i^2$ . Stipulating this, then, suggests that confidence

limits on  $m_R = m_{0.5} - z\sigma$  itself should be of interest. This possibility has not been mentioned in the EC-135 reports, it appears.

Approximate confidence limits for the above margin can be constructed in various ways. For example, in the delta (or linearization) method, compute

$$\begin{aligned} \text{Var}[\hat{m}_R] &= \text{Var}[\hat{m}_{0.5}] + z^2 \text{Var}[\hat{\sigma}] \\ &= \sum_{i=1}^k \frac{\hat{\sigma}_i^2}{n_i} + \frac{z^2}{\left(\hat{\sigma}_1^2 + \dots + \hat{\sigma}_k^2\right)^{1/2}} \sum_{i=1}^k \frac{\hat{\sigma}_i^4}{n_i - 1}. \end{aligned}$$

See Cramér (1946), pp. 353-356 for details. Also applicable are jackknifing (Chapter 8 of Mosteller and Tukey, 1977; Efron, 1981; Mallows and Tukey, 1983) and bootstrapping (Efron, 1981; Mallows and Tukey, 1983).

#### REFERENCES FOR APPENDIX E

- Alexander, D. R. and E. W. Enlow. 1981. Predicting lower bounds on failure power distributions of silicon NPN transistors. IEEE Transactions on Nuclear Science NS-28(6):4305-4310. December.
- Ashley, C. and J. V. Locasso. 1977. A Brief Presentation and Discussion of the Algorithm Used to Determine EC-135 EMP Margin Reliability-Confidence. Kirtland Air Force Base, New Mexico: Air Force Weapons Laboratory and Rockwell International Autonetics Group (System Design and Assessment Note 23). September 27.
- Brownlee, K. A. 1965. Statistical Theory and Methodology in Science and Engineering. Second Edition. New York: John Wiley & Sons.
- Cox, D. R. and D. V. Hinkley. 1974. Theoretical Statistics. New York: Halsted Press, a division of John Wiley & Sons (U.S. distributor). (Chapman and Hall, principal publishers.)
- Cramér, H. 1946. Mathematical Methods of Statistics. Princeton, New Jersey: Princeton University Press.
- Efron, B. 1981. Nonparametric estimates of standard error: the jackknife, the bootstrap, and other methods. Biometrika, Vol. 68.

- Mallows, C. L. and J. W. Tukey. 1983. An overview of techniques of data analysis, emphasizing its exploratory aspects. Chapter 7 in *Some Recent Advances in Statistics*, Tiego de Oliveira, ed. London: Academic Press.
- Mosteller, F. and J. W. Tukey. 1977. *Data Analysis and Regression*. Reading, Massachusetts: Addison-Wesley.
- Rockwell International Corporation. 1978. EC-135 EMP Assessment Program. Assessment Error Analysis (prepared by Autonetics Division for Air Force Weapons Laboratory). Anaheim, California. April.
- Satterthwaite, F. E. 1946. An approximate distribution of estimates of variance components. *Biometrics Bulletin* 2:110-114.
- Shewhart, W. A. 1939. *Statistical Method from the Viewpoint of Quality Control*. Chapter 2. Washington: The Graduate School, U.S. Department of Agriculture.
- Wald, A. and J. Wolfowitz. 1946. Tolerance limits for a normal distribution. *Annals of Mathematical Statistics* 17:208-215.
- Wilks, S. S. 1941. On the determination of sample sizes for setting tolerance limits. *Annals of Mathematical Statistics*, Vol. 17.
- Wunsch, D. C. and R. R. Bell. 1968. Determination of threshold failure levels of semiconductor diodes and transistors due to pulse voltages. *IEEE Transactions on Nuclear Science* NS-16(6):244-259. December.

## APPENDIX F

### ESTIMATING PROBABILITY OF SURVIVAL OF A COMPONENT BASED ON STRESS-STRENGTH MODELS

#### THRESHOLD LEVEL AND THREAT LEVEL

Failure threshold will be defined herein as the stress level at or above which a component, device, subsystem, or facility will fail to perform its intended function. It can be expressed in volts, amperes, watts, or decibels relative to some reference stress level. In the decibel domain, the random variable threshold will be denoted herein by T.

The threat level is the level to which the item (device, subsystem, or facility) may be exposed to stress, expressed in the same units as failure threshold. In the decibel domain, the random variable electromagnetic pulse (EMP) stress is denoted by S.

The random quantities T and S can be defined at any point in a system. For an entire system chosen at random from nominally similar systems, T is the stress level that cannot be exceeded for survival of the system (that is, specified performance of its designated mission); and S is the level of EMP threatening the system. At component level, T describes the stress level at which a random component is destroyed or fails to function in the required manner; and S describes the EMP stress that may be seen at the input terminal of the component.

The value of T depends on the failure mechanism, since one failure threshold level might mean temporary degradation of the operation of the system, another level might mean permanent but not complete degradation, and another level might mean the system's total destruction. We assume here that the type of dysfunction has been specified.

#### SAFETY MARGIN

The random variable "safety margin" for a random item is defined as  $M = k(T - S)$ , where k is some known positive constant. The value of M is, of course, also given in decibels.

If safety margin for a particular component, system, or other unit is positive, then the item will be unimpaired by the threatening EMP



if and when the threat is realized. On the other hand, if the safety margin is negative, the item will be impacted (for example, upset or damaged) upon realization of the threatening stress.

#### STATISTICAL ASSESSMENT

Typically in practice, tests to estimate failure threshold level for a random item in a population are made by exposing to stress a size- $n$  random sample of components, devices, or systems. See the sections on accelerated tests in Mann and Singpurwalla (1983) for a discussion of typical procedures for performing such stress tests. The exposure might be to several fixed levels of stress, with the experimenter observing the proportions that fail at each level. Alternatively, one might increase the stress by some organized procedure until a specified number of the sample fails, or until a prescribed stress level is reached, noting in each case the decibel level that precipitates failure.

The latter testing model can yield a sample of values,  $t_1, \dots, t_r$ ,  $r$  less than or equal to  $n$ , of the random variable,  $T$ , if the stress is increased continuously. In all cases, results can be expressed in the form of a histogram, with threshold levels categorized and the frequency of failure indicated for each category.

From each value  $t$  of the random variable  $T$ , we can subtract a value  $s$  of  $S$  corresponding to an appropriate level of stress for the EMP threat to the item. We thereby obtain an observed value  $m$  of the random variable  $M$ , which represents the safety margin for a random item in the population of items. We may want to know the probability  $p$  that  $M$  is greater than 0 in the population, that is,  $p = P\{M > 0\}$ . We may want a point estimate of the quantity  $p$ ; but more likely we will wish to attach some statistical level of confidence and say, for example, that at the 95 percent confidence level,  $p$  is greater than  $p' = 0.992$ ; that is, the probability of a random item in the population not failing is greater than 0.992. The value 0.992 would, of course, be an evaluation based on the data.

To obtain a value of  $p'$  corresponding to some given confidence level, we need data and a model--or a device for coping with the lack of a model. Herein lies the source of the problem. First, there is little agreement concerning an appropriate distribution for threshold level, that is, the random variable,  $T$ , although some study has been done in this area. See, for example, Alexander, Karaskiewicz, and Enlow (1981) and Jones (Appendix B, presentation on May 21, 1983).

Some agree that  $T$ , as measured in decibels, has a normal (Gaussian) distribution; but Alexander, Karaskiewicz, and Enlow (1981) found conflicting results. Graphical plotting of the data on various probability papers might shed further light on this issue.

Boeing Company (1981) makes a case for using a particular Beta distribution to describe the variation in stress of the EMP threat, but there has been no real empirical verification of such an assumption. Paul Ryl (Appendix B, presentation on June 1-2, 1983) discusses inherent difficulties in doing this, including possibly unjustified linearity assumptions and general difficulties simulating rise times, peak power, total energy, and so forth.

Clement and Johnson (1981) seem to assume that both T and S are normally distributed in the decibel domain and, consequently, that M, being a linear combination of Gaussian variates, is normal as well. Clement and Johnson use a first-order Taylor-series expansion (the "delta method") for expressing M when it is other than a linear function.

In the presentation by Ryl mentioned earlier, he suggests, in the light of difficulties in finding parametric models for the distribution of M, that one assume only that the values of safety margin for every item in a sample are independent and identically distributed and therefore that the number X of occurrences of M greater than 0 is a binomially distributed variate. For this reason he suggests using the binomial model for determining a lower confidence bound on p corresponding to a particular level of confidence. Procedures for doing this make use of the incomplete Beta function and are described in many places, for example, pp. 372-375 in Mann, Schafer, and Singpurwalla (1974). Ryl mentions informally the use of a "Bayesian binomial" with an assumption of a uniform prior probability distribution for p.

In response to the suggestion of a uniform prior distribution for p, one might consider results tabulated on page 499 in Mann, Schafer, and Singpurwalla (1974). These results indicate that when inference is at the component level only (rather than inference to systems on the basis of component data), using a uniform prior for p is considerably less conservative than using the traditional assumption of  $-\ln p$  uniform on the positive half real line. The latter assumption produces optimal nonrandomized confidence bounds for p, in that they give the shortest confidence intervals with corresponding assigned confidence level. If a binomial model is used with component data in combining components to predict the value of p for a system, then Section 10.4 of Mann, Schafer, and Singpurwalla (1974) should be consulted.

An assumption that might possibly not be satisfied for the binomial model is that the process is in control and that p is the same for each sample generated. (See Mood, 1943.) If the outcomes depend upon more than a single mechanism, it is possible that the distribution of X (the number of occurrences of M greater than 0) may be a mixture of binomials. Whether or not this is so, one should be aware that a binomial model that lacks prior information requires extremely large sample sizes to predict large values of p. If p is very much larger than  $1 - 1/n$ , with n equal to sample size, estimates of p will tend to

be equal to one and hence of little use in extrapolating to systems. What could be helpful here is a starting place so as to be able to begin to build appropriate models by using the best data available so that one can make inferences about the lower tail of the distribution of  $M$  and hence predict  $p$  effectively.

#### A POSSIBLE METHOD OF ATTACKING PREDICTION OF $p$

A first step in solving the problem of efficient prediction of  $p$  is to find the largest good quality data sets available for the problem of interest. Needed are samples of values of threshold  $T$  obtained from stress testing random samples of specified items of concern. Non-categorical data or data corresponding to many categories are much preferred.

Along with these samples, one needs random samples of values of the random variable,  $S$ , roughly approximating the sizes of the samples of failure thresholds. The closer these are to values that EMP pulses are expected to induce, the better. One might then use a technique specifically designed for non-parametric density estimation. See Tarter and Marshall, (1978). This technique relies on the relatively simple mean and variance-covariance structure and asymptotic normality of the sample trigonometric moments. However, the technique has not yet been tried in the EMP context.

#### REFERENCES FOR APPENDIX F

- Alexander, D. R., R. J. Karaskiewicz, and E. W. Enlow. 1981. Component Statistical Characterization. Final Report. Part 1 of 4. Kirtland Air Force Base, New Mexico: Air Force Weapons Laboratory (AFWL-TR-80-128, Pt. 1). September.
- Boeing Company. 1981. HEMP Protection Capabilities as Indicated by the NAVCAMS EASTPAC TEMPS Tests. Washington: Defense Nuclear Agency (D194-30024-1). Pp. 44-47. June 30.
- Clement, D. M. and A. W. Johnson. 1981. Satellite survivability estimates. IEEE Transactions on Nuclear Science NS-28(6):4198-4203. December.
- Mann, N. R., R. E. Schafer, and N. D. Singpurwalla. 1974. Methods for Statistical Analysis of Reliability and Life Data. New York: John Wiley & Sons.

- Mann, N. R. and N. D. Singpurwalla. 1983. Life testing. In Encyclopedia of Statistical Sciences, S. Kotz, K. L. Johnson, and Read, eds. New York: John Wiley & Sons.
- Mood, A. M. 1943. On the dependence of sampling inspection plans upon population distributions. Annals of Mathematical Statistics 14(2):415-425.
- Tarter, M. E. and J. S. Marshall. 1978. A new nonparametric procedure designed for simulation studies. Communications in Statistics B7(3):283-294.

## APPENDIX G

### TUTORIAL ON FAULT TREE ANALYSIS

Some of the presentations (Appendix B, by Newman on April 1-2, 1983, and by Mensing on August 9-10, 1983) to the committee alluded to the possibility of using fault tree analysis (FTA) for electromagnetic pulse (EMP) assessment. None of the presentations discussed a specific application of FTA in the context of interest. Thus, it was thought that a tutorial appendix on FTA emphasizing the key ideas, notions, terminology, uses, and difficulties would be of benefit to the EMP assessment community. The references cited here should be consulted for a more detailed understanding of FTA. A key reference is Barlow (1983), which contains the latest material on the subject.

#### FAULT TREES

Fault tree analysis was conceived by H. R. Watson, of Bell Telephone Laboratories, in the early 1960s, for the safety evaluation of complex systems. The technique was further developed by D. F. Haasl, of Boeing Company. It is currently being widely used in engineering safety analysis, failure modes and effects analysis, societal risk analysis, analyses of the risks of transporting hazardous material, and, most importantly, the assessment of the risk of nuclear accidents. This application is described by the U.S. Nuclear Regulatory Commission (1975) in its well known WASH-1400 study, commonly referred to as the "Rasmussen report." It is fair to say that by now the technique has generated a substantial clientele.

Mathematically, a fault tree can be viewed as a set of nodes,  $N$ , and a set of arcs,  $A$ , with direction. Any pair of nodes may be joined by at most a single arc, which may be a "regular arc" or a "complementing arc," and which exits one of the nodes and enters the other. Any node can be characterized as a basic node, which has no entering arcs, or as a gate node, which has both entering and leaving arcs, or as a top node. A fault tree has a single top node. The top node corresponds to a serious event, such as system failure, nuclear accident, or system not EMP-hardened. Typically, there are few if any, data available for the top node (event). A basic node is one for

which there is no intention of further analysis. A basic node would correspond, for example, to the failure of a small component or a sub-system not EMP-hardened; typically, one has many data and much experience for a basic node (event). Gate nodes correspond to intermediate events, for which there may or may not be many available data. Figure 1 illustrates a fault tree with basic nodes labeled from 9 to 14, the top node labeled 1, and the gate nodes labeled from 2 to 8.

A tree is constructed top down deductively by engineers and system analysts who have an intimate knowledge of the system. However, the analysis and the flow of logic is upwards, from the basic nodes to the top node. Thus the arcs in Figure 1 have arrows that point upwards.

Associated with each gate is a logic symbol. The or gate denoted by the symbol  $\oplus$  implies set union, and the and gate denoted by the symbol  $\Delta$  implies set intersection. Thus for example, the gate event labeled 3 occurs if and only if either the gate event 4 or the gate event 5, or both, occur. The gate event 5 occurs if and only if both the gate events 7 and 8 occur. The arc connecting the gate events 4 and 6 is a complemented arc denoted by " $\sim$ "; this terminology means that the gate event 4 will occur if and only if the basic event 11 occurs and the gate event 6 does not occur.

Fault trees of large and complex systems involve a logic that may be more elaborate than the set-union and the set-intersection logic mentioned above. To account for these situations, other types of gates are used--the more typical ones being the exclusive or gate and the priority and gate, denoted by other symbols. In the former, the output event occurs if exactly one of the inputs occurs, whereas with the latter, the output event occurs if all the inputs occur in a specified order. Another gate commonly employed is the k out of n logic gate, denoted by "k/n." Here, the output event occurs if at least k of the n input events occur.

Figure 2 illustrates the role of the gate logic in constructing a fault tree. The event of interest here is the failure of component A, which is required to perform some function for a duration of 7 hours. As is illustrated, component A is said to have failed if it either fails to start on demand or if it starts on demand and it fails to function for the desired 7 hours. The or gate under the top event is the appropriate one here. The role of the intermediate and gate should be clear from the context considered. A good source for more detailed information on the construction of fault trees is the U.S. Nuclear Regulatory Commission's Fault Tree Handbook (Vesely et al., 1981).

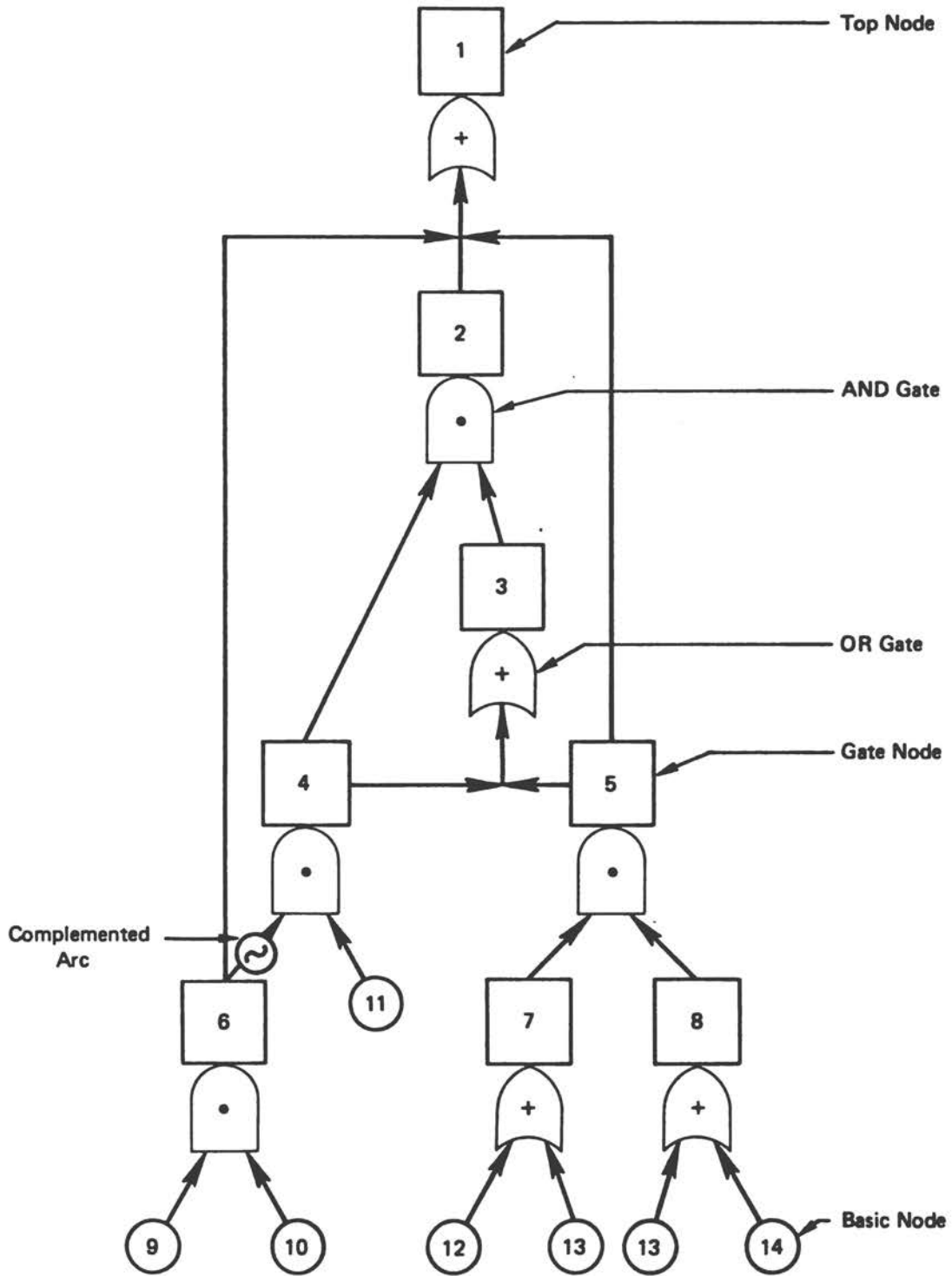

SOURCE: After Barlow (1983)

FIGURE 1 An illustration of a fault tree.

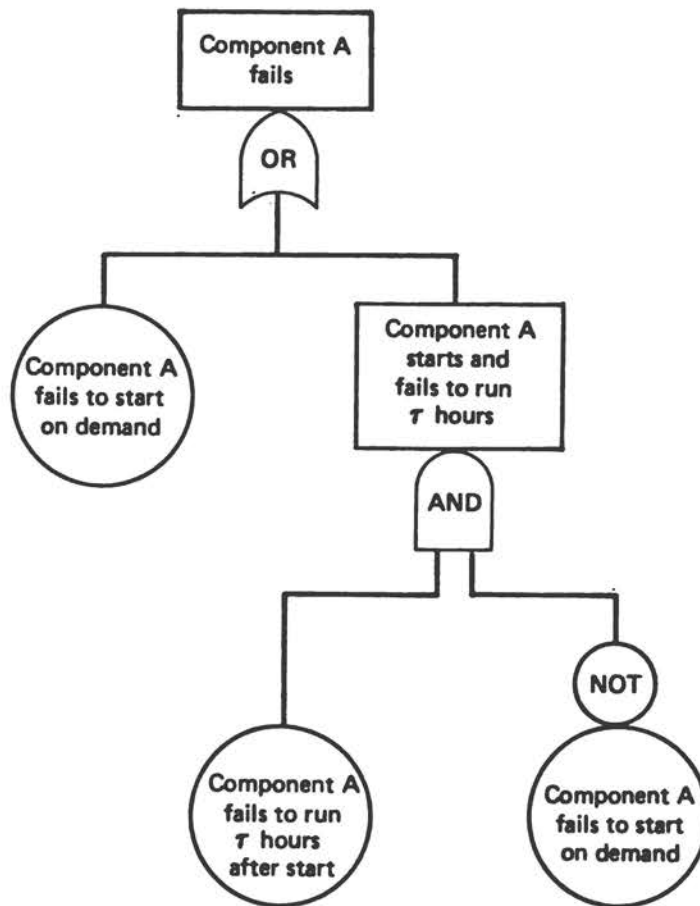

SOURCE: After Vesely et al. (1981)

FIGURE 2 Role of the gate logic in constructing a fault tree.



### WHY ARE FAULT TREES USEFUL?

From the above discussion, it should be obvious that the fault tree is a useful tool for the analysis of a system design. Specifically, the fault tree functions as follows:

1. It serves as an aid in determining the possible causes for the occurrence (or not) of the top event.
2. It may lead one to the discovery of event combinations that otherwise might not have been recognized.
3. It enables one to compare and contrast various designs or, for example, different strategies for the EMP hardening of a large system.
4. It enables one to pinpoint critical event scenarios via calculation of what are known as the importance measures. Importance measures would be important within the context of EMP hardening if one were to selectively harden a system. It would pinpoint those components and subsystems on which one should concentrate hardening efforts, given that shielding the whole system was untenable or prohibitively expensive.
5. Finally, and most importantly, a fault tree enables one to compute a numerical impression of the probability of occurrence of the top event when few or no data on its occurrence are available. In the context of EMP assessment, the calculation of the probability of the top event enables one to compare two competing hardening schemes.

### THE MATHEMATICAL ANALYSIS OF A FAULT TREE

The analysis of a fault tree is based on Boolean switching theory and, as such, uses binary variables taking on values 0 and 1. A good reference for the mathematics of fault trees is Barlow et al. (1975).

Central to the analyses of a fault tree is the notion of min cut sets. If the top event of a tree (without complementing arcs) represents failure, then a min cut set is the smallest combination of component failures that, if they all occur, will cause the top event to occur. (If any one of the failures in a cut set does not occur, the top event will not occur.) Any fault tree will consist of a finite number of min cut sets that are unique for the top event. For the fault tree of Figure 1, the min cut sets are (9, 10), (12, 14), (13), and (11).

### A Difficulty with the Practical Implementation of Fault Tree Analysis

It has been shown that the problem of finding the complete min cut set family of a fault tree is a member of the class of so-called

NP-complete problems, a subset of the class of nondeterministic, polynomial-time (NP) problems. That is, we cannot expect to devise an algorithm whose running time is bounded for all fault trees by a polynomial in the number of nodes. For example, a tree with more than 100 gate nodes with an appreciable number of or gates may have millions of sets in the min cut set family. Thus, in practice, it is possible that a particular fault tree may pose some practical problems with the implementation of its analysis, because of one's inability to enumerate all its min cut sets.

#### Algorithms for Finding the Min Cut Sets

Several algorithms and computer codes for determining the min cut sets of fault trees have been devised, most of them under the aegis of the U.S. Nuclear Regulatory Commission. A simple and powerful algorithm, suitable for trees without complemented arcs, is due to Fussell and Vesely (1982). An algorithm for trees with complemented arcs is due to Worrell (1975). Various computer codes, and their characteristics, for generating the min cut arc sets of a fault tree are described in the literature. Potential users of FTA for EMP assessment work may find this information useful.

#### Calculating the Probability of Occurrence of Any Node Fault

Once a fault tree has been drawn and its min cut sets enumerated, the next step is the calculation of the probabilities of occurrence of the various gate nodes and the top node. The general principle used here is that of inclusion-exclusion. Thus for example, the fault tree of Figure 1, which has as its min cut sets  $S_1 = (9, 10)$ ,  $S_2 = (12, 14)$ ,  $S_3 = (13)$  and  $S_4 = (11)$ , will give the probability of the top node occurrence as

$$\begin{aligned}
 P\{\text{top node occurs}\} &= P\left\{\bigcup_{i=1}^4 S_i\right\} \\
 &= \sum_{i=1}^4 P(S_i) - \sum_{i<j} P\{S_i \cap S_j\} + \sum_{i<j<k} P\{S_i \cap S_j \cap S_k\} \\
 &\quad - P\{S_1 \cap S_2 \cap S_3 \cap S_4\}, \quad (1)
 \end{aligned}$$

where " $\cup$ " denotes the event that one or more constituent event occurs and " $\cap$ " denotes that both events occur.

The above expression reveals the important role that min cut sets might play, when calculation is feasible, in evaluating the probability of occurrence of the top node.

If it is assumed that each basic node of Figure 1 has  $10^{-3}$  as its probability of occurrence, and most importantly, if the basic node events are assumed to be statistically independent, then the computations of (1) would yield

$$P\{\text{top node occurs}\} \approx 2 \times 10^{-3}.$$

As a general principle, it is to be noted that if the number of min cut sets in a fault tree is  $q$ , then the total number of terms in the inclusion exclusion-principle calculation is  $2^q - 1$ ; thus, for example, if  $q = 20$ , the number of terms in the calculation is about  $10^6$ . The magnitude of these calculations may be regarded as another difficulty in the practical implementation of FTA. A Monte Carlo analysis of the fault tree avoids many of the above problems.

In addition to being able, in small problems, to calculate the probability of occurrence of the top node, the min cut sets also enable us, in such problems, to compute the "availability" of the system, such as an aircraft or a reactor, and the importance ranking of the various basic nodes. Importance ranking in the context of EMP assessments was mentioned above as point 4 in connection with the usefulness of fault trees.

Various computer codes, their characteristics and limitations, and their sources of availability for calculating the probabilities of occurrence of the basic nodes and the importance measures of fault trees are described in the literature. This information should prove useful to a potential user.

#### APPLICATION OF FAULT TREE ANALYSIS TO ELECTROMAGNETIC PULSE ASSESSMENTS

It appears that the technique of fault tree analysis is potentially a very useful tool for EMP assessments of large and complex systems. However, there are some difficulties of which a prospective user should be aware. These difficulties are not insurmountable; but, all the same, care and caution are necessary. Specifically, FTA can be used for the following tasks:

1. To conduct an engineering analysis of a system and its hardening with respect to its vulnerability to an EMP attack.
2. To generate a numerical measure, via a probability of survival, of the vulnerability of a system and its hardening with respect to a previously specified EMP attack for which the probabilities of failure of individual elements can be estimated and where these failures are reasonably independent.

3. To compare and contrast several competing designs and schemes of hardening of a large system, which is vulnerable to an EMP attack.
4. Given that a system cannot be completely shielded and that its components and subsystems must be selectively hardened, to help identify and rank those components and subsystems in terms of the degree of attention that they need.
5. Given the vulnerability or the hardening capabilities of the components and subsystems of a large system, to enable one to evaluate the vulnerability and hardening capabilities of the entire system.

#### Some Difficulties with the Application of Fault Tree Analysis

The above notes of optimism should be tempered with the following points of caution:

1. The construction of a fault tree for EMP assessment calls for much skill and imagination on the part of engineers and designers who analyze the system. One has to anticipate unusual circumstances and combinations of events that may make a system vulnerable to an EMP attack. Thus patience is called for, as well as consultation with as many specialists as are necessary. It is impossible to assure that a particular fault tree is a satisfactory description of the system. However, as we have seen throughout this report, there may be ways of designing the system to reduce the chances of unexpected effects and, thereby, to make the system more assessable.
2. The analysis of a fault tree requires, as an input, the probabilities of occurrence of the basic nodes. (In the example of Figure 1, these were all assumed to be  $10^{-3}$ .) In practice such inputs may be hard to come by, and it is here that subjective notions and Bayesian statistics may play an essential role. The latter concepts, of course, are not without much criticism and debate. However, in the face of reality one is asked to make EMP assessments and decisions; and one may not have much choice but to be accommodating to expert and subjective inputs.
3. In practice it is frequently assumed that the basic node events are independent--this is the assumption in the section entitled "Calculating the Probability of Occurrence of Any Node Fault." It is difficult and also time consuming to model dependencies between the basic node events, the difficulties increasing with the number of node events considered. If the basic node events are positively correlated, as is often the case with physical systems, then the assumption of independence yields upper or

lower bounds on the probabilities of occurrence of the various gate nodes. The nature of these bounds depends on the logic symbol associated with each gate, and in practice the bounds may be too wide to give any meaningful insight about the probability assessed. In Mastran and Singpurwalla (1978) the problem of component dependencies in assessing system reliability is addressed and should prove useful. Much more basic research needs to be done here.

4. A final difficulty with the practical implementation of fault trees is that generated by the computational problems associated with large trees. This difficulty will of course diminish with the new generation of high speed computers.

#### REFERENCES FOR APPENDIX G

- Barlow, R. E. 1983. Fault Tree Analysis. Pp. 34-39 in The Encyclopedia of Statistical Sciences, Vol. 3, S. Katz and N. L. Johnson, eds. New York: John Wiley & Sons.
- Barlow, R. E., J. B. Fussell, and N. D. Singpurwalla, eds. 1975. Reliability and Fault Tree Analysis. Philadelphia: Society for Industrial and Applied Mathematics.
- Fussell, J. B. and W. E. Vesely. 1972. New methodology for obtaining cut sets for fault trees. Transactions of the American Nuclear Society 15:262-263.
- Mastran, D. V. and N. D. Singpurwalla. 1978. A Bayesian estimation of the reliability of coherent structures. Operations Research 26:663-672.
- U. S. Nuclear Regulatory Commission. 1975. Reactor Safety Study: An Assessment of Accident Risks in U. S. Commercial Nuclear Power Plants. Washington (NRC Report WASH-1400, NUREG-75/014, also known as the "Rasmussen report"). October.
- Vesely, W. E., F. F. Goldberg, N. H. Roberts, and D. F. Haasl. 1981. Fault Tree Handbook. Washington: U. S. Nuclear Regulatory Commission (NUREG-0492).
- Worrell, R.B. 1975. Pp. 165-185 in Reliability and Fault Tree Analysis, R. E. Barlow, J. B. Fussell, and N. D. Singpurwalla, eds. Philadelphia: Society for Industrial and Applied Mathematics.

## GLOSSARY

**AFWL:** Air Force Weapons Laboratory.

**dB:** Decibels.

**DNA:** Defense Nuclear Agency.

**DOD:** U. S. Department of Defense

**EM:** Electromagnetic.

**EMP:** Electromagnetic pulse.

**FTA:** Fault tree analysis.

**GWEN:** Ground Wave Emergency Network

**km:** Kilometers.

**kV:** Kilovolts.

**kV/m:** Kilovolts per meter.

**LPM:** Lumped parameter model.

**MeV:** Million electron volts.

**MHz:** Megahertz.

**MILSPEC:** Military specification.

**POS:** Probability of survival.

**TRESTLE:** A large-scale electromagnetic pulse simulator at Air Force Weapons Laboratory, Kirtland Air Force Base, New Mexico

**VHSIC:** Very high speed integrated circuits.

**VLSI:** Very large scale integration.

