



## **Enabling Technologies for Unified Life-Cycle Engineering of Structural Components**

Committee on Enabling Technologies for Unified Life-Cycle Engineering of Structural Components, Commission on Engineering and Technical Systems, National Research Council

ISBN: 0-309-58339-X, 112 pages, 6 x 9, (1991)

**This PDF is available from the National Academies Press at:**  
**<http://www.nap.edu/catalog/1776.html>**

Visit the [National Academies Press](http://www.nap.edu) online, the authoritative source for all books from the [National Academy of Sciences](http://www.nap.edu), the [National Academy of Engineering](http://www.nap.edu), the [Institute of Medicine](http://www.nap.edu), and the [National Research Council](http://www.nap.edu):

- Download hundreds of free books in PDF
- Read thousands of books online for free
- Explore our innovative research tools – try the “[Research Dashboard](#)” now!
- [Sign up](#) to be notified when new books are published
- Purchase printed books and selected PDF files

**Thank you for downloading this PDF. If you have comments, questions or just want more information about the books published by the National Academies Press, you may contact our customer service department toll-free at 888-624-8373, [visit us online](#), or send an email to [feedback@nap.edu](mailto:feedback@nap.edu).**

**This book plus thousands more are available at <http://www.nap.edu>.**

Copyright © National Academy of Sciences. All rights reserved.

Unless otherwise indicated, all materials in this PDF File are copyrighted by the National Academy of Sciences. Distribution, posting, or copying is strictly prohibited without written permission of the National Academies Press. [Request reprint permission for this book.](#)

---

---

# **EBABLING TECHNOLOGIES FOR UNIFIED LIFE-CYCLE ENGINEERING OF STRUCTURAL COMPONENTS**

Committee on Enabling Technologies for Unified Life-Cycle Engineering of Structural  
Components  
National Materials Advisory Board  
Commission on Engineering and Technical Systems  
National Research Council

Publication NMAB-455  
National Academy Press  
Washington, D.C. 1991

NOTICE: The project that is the subject of this report was approved by the Governing Board of the National Research Council, whose members are drawn from the councils of the National Academy of Sciences, the National Academy of Engineering, and the Institute of Medicine. The members of the committee responsible for the report were chosen for their special competences and with regard for appropriate balance.

This report has been reviewed by a group other than the authors according to procedures approved by a Report Review Committee consisting of members of the National Academy of Sciences, the National Academy of Engineering, and the Institute of Medicine.

The National Academy of Sciences is a private, nonprofit, self-perpetuating society of distinguished scholars engaged in scientific and engineering research, dedicated to the furtherance of science and technology and to their use for the general welfare. Upon the authority of the charter granted to it by the Congress in 1863, the Academy has a mandate that requires it to advise the federal government on scientific and technical matters. Dr. Frank Press is president of the National Academy of Sciences.

The National Academy of Engineering was established in 1964, under the charter of the National Academy of Sciences, as a parallel organization of outstanding engineers. It is autonomous in its administration and in the selection of its members, sharing with the National Academy of Sciences the responsibility for advising the federal government. The National Academy of Engineering also sponsors engineering programs aimed at meeting national needs, encourages education and research, and recognizes the superior achievements of engineers. Dr. Robert M. White is president of the National Academy of Engineering.

The Institute of Medicine was established in 1970 by the National Academy of Sciences to secure the services of eminent members of appropriate professions in the examination of policy matters pertaining to the health of the public. The Institute acts under the responsibility given to the National Academy of Sciences by its congressional charter to be an adviser to the federal government and, upon its own initiative, to identify issues of medical care, research, and education. Dr. Samuel O. Thier is president of the Institute of Medicine.

The National Research Council was organized by the National Academy of Sciences in 1916 to associate the broad community of science and technology with the Academy's purposes of furthering knowledge and advising the federal government. Functioning in accordance with general policies determined by the Academy, the Council has become the principal operating agency of both the National Academy of Sciences and the National Academy of Engineering in providing services to the government, the public, and the scientific and engineering communities. The Council is administered jointly by both Academies and the Institute of Medicine. Dr. Frank Press and Dr. Robert M. White are chairman and vice chairman, respectively, of the National Research Council.

This study by the National Materials Advisory Board was conducted under Contract No. MDA903-89-K-0078 with the U.S. Department of Defense and the National Aeronautics and Space Administration.

Library of Congress Card Number 91-60825.

International Standard Book Number 0-309-04492-8.

This report is available from the National Academy Press, 2101 Constitution Avenue, NW, Washington, DC 20418. Also, available from the Defense Technical Information Center, Cameron Station, Alexandria, VA 22304-6145.

S347.

Printed in the United States of America.

## ABSTRACT

This report addresses the application of unified life-cycle engineering approaches to the design, manufacture and application of structural components, especially structural components for advanced military weapons systems. Unified life-cycle engineering (ULCE), or concurrent engineering, is a design engineering environment in which computer-aided design technology is used to assess and improve the quality of a product not only during the active design phases but throughout its entire life cycle by integrating and optimizing design attributes for producibility and supportability as well as for performance, operability, cost, and schedule. The study identifies and evaluates priorities for research and development in life-cycle engineering with the goal of identifying the enabling technologies that underpin ULCE, their readiness for application, and the research and development required to make them commercially available in a 10-year period. The committee examined the current and desired future environments for five factors in a product's life cycle: design, manufacture, product support, materials, and information systems. Four critical issues are identified and conclusions and recommendations to support the development of an effective ULCE design engineering environment are defined.

About this PDF file: This new digital representation of the original work has been recomposed from XML files created from the original paper book, not from the original typesetting files. Page breaks are true to the original; line lengths, word breaks, heading styles, and other typesetting-specific formatting, however, cannot be retained, and some typographic errors may have been accidentally inserted. Please use the print version of this publication as the authoritative version for attribution.

---

---

## COMMITTEE ON ENABLING TECHNOLOGIES FOR UNIFIED LIFE-CYCLE ENGINEERING OF STRUCTURAL COMPONENTS

### Chairman

Michael J. Buckley, Rockwell International Science Center, Palo Alto Laboratory, California

### Members

J. Kenneth Blundell, University of Missouri-Columbia

Ronald C. Fix, McAir CAD/CAM, St. Louis, Missouri

Siegfried Goldstein, Siegfried Enterprises, Inc., North Babylon, New York

Charles F. Herndon, General Dynamics Corporation, Fort Worth, Texas

Richard Lopatka, Pratt & Whitney Manufacturing Division, East Hartford, Connecticut

Yoh-Han Pao, Case Western Reserve University, Cleveland, Ohio

Ralph E. Patsfall, General Electric Company, Cincinnati, Ohio

Robin Stevenson, General Motors Technical Center, Warren, Michigan

Edison T. S. Tse, Stanford University, Stanford, California

Dick Wilkins, University of Delaware, Newark

David H. Withers, IBM Industrial Sector Division, Atlanta, Georgia

H. Thomas Yolken, National Institute of Standards and Technology, Gaithersburg, Maryland

---

### **Liaison Representatives**

Walter H. Reimann, WRCD/ML, Wright Patterson Air Force Base, Ohio  
Melvin C. Ohmer, WRDC/ML, Wright Patterson Air Force Base, Ohio  
Dan E. Good, Aviation Applied Technology Directorate, Ft. Eustis, Virginia  
John Mayer, National Science Foundation, Washington, DC  
Charles A. Zanis, Naval Sea Systems Command, Washington, DC  
Lewis Sloter, Naval Air Systems Command, Washington, DC  
Richard Weinstein, National Aeronautics and Space Administration, Washington, DC

### **NMAB Staff**

Klaus M. Zwilsky, Director  
Stanley M. Wolf, Project Officer (1987–1988)  
Cathryn Summers, Senior Secretary

## PREFACE

The development of complex military weapons systems has always required that the design team make numerous decisions regarding the use of advanced, unproved technology to achieve improved performance and enhanced cost-effectiveness. The continuing need for better performance has generally led to the technological approach that offers the highest performance consistent with program cost and schedule constraints. Systems are often developed that require considerable modification before they can be efficiently manufactured and considerable support in the field once they are deployed.

Unified life-cycle engineering (ULCE) is a concept aimed at providing designers with integrated knowledge and information needed throughout a weapon system's life cycle--from design through product support. This enlarged information set could significantly upgrade weapons systems design and performance as well as shorten development and prototype demonstration times. ULCE has the goal of providing the designer or engineer with information and tools that will permit the consideration of more issues and perform more trade-off studies within the time constraints. Just as the widespread use of word processing programs (a tool) at individual workstations has increased the quality of letters and reports by making it far easier to edit and format documents, so in principle will ULCE design stations improve the quality of design by making it far easier to consider explicitly issues that previously were addressed only with great difficulty, if at all.

The Department of Defense and National Aeronautics and Space Administration requested the National Research Council, through the National Materials Advisory Board, to examine ULCE for structural components. The study was charged with identifying and evaluating priorities in R&D opportunities in the area of ULCE of structural components and with assessing the enabling technologies for ULCE (including the needs and relationships among several technologies--materials, structural design, component manufacture, product support, and information systems).

This report documents the findings of the study. It emphasizes technical issues associated with ULCE and institutional issues are also considered. Its intended audiences are government and industry executives who set policy for their organizations as well as program managers in funding agencies responsible for identifying and responding to opportunities for improved system reliability.



The committee appreciates contributions from several individuals who made presentations at committee meetings and thus assisted in the completion of this study; Appendix C lists these individuals as well as summaries of the key issues they discussed.

MICHAEL J. BUCKLEY  
CHAIRMAN

## CONTENTS

	Executive Summary	1
1	INTRODUCTION	5
	Objective	6
	Approach	7
	Unified Life-Cycle Engineering	9
	Potential Payoff	10
	Current and Future Environment	10
	Validity of Study Findings for Other Products	12
	References	12
2	DESIGN	13
	Current Environment	13
	Future Environment	16
	Significance of the Change	17
	References	17
3	MANUFACTURING	19
	Current Environment	19
	Future Environment	20
	Significance of the Change	22
4	PRODUCT SUPPORT	25
	Current Environment	25
	Future Environment	28
	Significance of the Change	28

5	MATERIALS	29
	Current Environment	29
	Future Environment	30
	Significance of the Changes	32
	References	32
6	INFORMATION SYSTEMS	35
	Current Environment	35
	Future Environment	37
	Significance of the Change	38
	References	38
7	CRITICAL ISSUES	39
	Validation	39
	Critical Issue 1	42
	Critical Issue 2	46
	Critical Issue 3	49
	Critical Issue 4	53
	References	58
8	CONCLUSIONS AND RECOMMENDATIONS	59
	General Conclusions and Recommendations	59
	Conclusions and Recommendations From First Critical Issue	62
	Conclusions and Recommendations From Second Critical Issue	63
	Conclusions and Recommendations From Third Critical Issue	65
	Conclusions and Recommendations From Fourth Critical Issue	67
	APPENDIX A Case Study of a Metallic Gas Turbine Disk	71
	APPENDIX B Case Study of a Composite Airframe Structure	81
	APPENDIX C Presentations to the Committee	89
	APPENDIX D Biographical Sketches of Committee Members	97

## EXECUTIVE SUMMARY

This report addresses the application of unified life-cycle engineering approaches to the design, manufacture and application of structural components and is further focussed on structural components for advanced military weapons systems.

Unified life-cycle engineering (ULCE) is a design engineering environment in which computer-aided design technology is used to continually assess and improve the quality of a product during the active design phases as well as throughout its entire life cycle by integrating and optimizing design attributes for producibility and supportability as well as for performance, operability, cost, and schedule.

The interest in the application of ULCE to the structural components of advanced weapons systems is prompted by the observation that in these systems the life-cycle cost is dominated by product support, with data for manned aircraft showing that 70 percent of life-cycle cost is associated with support after deployment.

The objective of the study was to identify and evaluate priorities for research and development in life-cycle engineering. The goal was to identify the enabling technologies that underpin ULCE, determine their readiness for application, and identify the research and development required to make them available in a 10-year period.

The development of complex military weapons systems has always required that the design team make numerous decisions regarding the application of new, unproven technology to achieve improved performance. The design team is often unable to achieve its design goals using well-established technology with known reliability, producibility, and cost. This continuing need for increased performance has generally led the design team to select the technological approach that offers the highest performance consistent with program cost and schedule constraints. Consequently, new systems usually require considerable maturation during the manufacturing and support phases of their life cycle. A fundamental goal of ULCE is to achieve as much of this maturation as possible during the design phase, thereby reducing the life-cycle costs and improving the reliability, availability, and maintainability of new weapons systems once they are deployed.

The basic approach envisioned for ULCE would utilize a series of computer-aided design tools and databases with capabilities consistent with the level of design then underway (conceptual or detailed). This approach would be sufficiently integrated to permit the conceptual design to

form the foundation of the detailed design without repeating or recreating prior operations. This new capability would permit the designer to analyze a system for the wide range of factors involved in the performance of a system or of its individual components. For example, the designer could perform a preliminary design using the computer-aided design (CAD) module of the ULCE system, evaluate its structural requirements by using the finite element models (FEM) module of the ULCE system, make a materials selection from the materials database of the ULCE system and evaluate the materials long-term resistance to environmental degradation under the expected operational conditions using the corrosion module of the ULCE system. To insure that the information in the ULCE system is constantly up to date, a "Lessons Learned" module would be required to input new performance data.

To reach its conclusions and recommendations, the committee examined the current and desired future environments for five factors in a product's life cycle: design, manufacture, product support, materials, and information systems. By analyzing the differences between the current and desired states and grouping like elements and eliminating redundancies, a list of needs and concerns was generated. From these needs and concerns the following set of four critical issues was developed and recommendations relating to each issue identified. Since this report, in general, deals with military systems, the recommendations are addressed to the federal government, specifically the Department of Defense (DOD). It is recognized that many of the recommendations would actually be implemented by industry under DOD guidelines. Moreover, the recommendations are applicable to industries that are using ULCE or concurrent engineering in their own planning irrespective of whether the work is undertaken for the government or not.

- ULCE- driven development of materials processing and repair methodologies requires integration of research and development across disciplines.

**Initiate and focus on materials research and characterization appropriate to the needs of ULCE.**

**Improve communication of ULCE needs within the materials community and governmental funding agencies.**

- Advanced analytical modeling and simulation methods that would lead to actual component manufacture, operation, and logistics do not exist to the extent required.

**Develop a model life-cycle cost calculator.**

**Accelerate the development of CAD-CAM systems that incorporate complete product descriptions material performance data, and manufacturing process information as well as features-based modeling for use with product and process modelers that support producibility, reliability, serviceability, etc.**

**Expand the application of analytical methods.**

- The information system for an integrated team approach to ULCE is inadequate.

**Build and implement a conceptual, system-level information reference model.**

**Develop and coordinate standard representations for entities in the ULCE system for unambiguous, reliable, and efficient retrieval, manipulation, and transfer of data.**

**Develop a rapid analysis tool for the conceptual design phase that embodies producibility and supportability.**

- The ULCE team will need to make key decisions while still operating with incomplete information.

**Develop and enhance capabilities to relate field observations to design attributes.**

**Develop improved sensor-based tools for periodic or continuous monitoring to assess remaining structural integrity of component materials.**

**Initiate and promote education and training in ULCE concepts and methods.**

**Develop better techniques to deal with missing or uncertain information.**

The committee concluded that because the development of ULCE requires a strong interdisciplinary research and development program involving a number of technologies; e.g., computer, materials, analytical modeling and simulation, decision theory as well as an equally strong educational commitment to support the program, the following general recommendations should be addressed prior to consideration of those identified under the critical issues:

- The overall scale of the ULCE effort should be defined; a detailed R&D plan and budget for a 10-to 15-year technology development program must be prepared.
- A demonstration project for ULCE should be established using a major subsystem or module of a current vehicle and then redesigning, reengineering or remanufacturing the subsystem or module.
- Lead responsibility for developing and implementing ULCE should be assigned to the Air Force, since it already has made a commitment to ULCE and generated a strong commitment to the concept. Mechanisms should be provided for calibrating with the Services and other government agencies.

The ULCE approach is not feasible at this time because current information systems are inadequate, the mathematical modeling capability is far less than needed, and materials data is lacking and fragmented. Further, to take full advantage of technological advances, decisions will have to be made in the absence of complete information; processes and technologies for minimizing risks in this area are not robust.

The breadth of issues to be addressed is vast. Although many of the technical goals may prove difficult or even impossible to achieve because of fundamental limits resulting from the computational complexity of the tasks, the committee is optimistic that a useful ULCE system can be developed by the year 2000 if sufficient resources are devoted to its development. This report provides a basis for initiating the longer-term, higher-risk research efforts as well as the

foundation for a more detailed analysis of the alternative technical approaches for meeting ULCE goals.

Any successful program will require the active participation of some of the best minds in the country, exceptional program management skills, and a considerable financial investment. The committee believes that, even though the challenges are major, the benefits justify initiating a significant research program as soon as possible.

# 1

## INTRODUCTION

Commercial and military engineering systems proceed through well-defined stages during their lifetimes—initial conceptualization, design, manufacture, distribution, delivery, installation, acceptance, support during operation (including retrofits), and disposal. Two competing goals have emerged relating to these stages and the cost of advanced military systems. The first goal is reducing the time required for design through delivery of a reliable and effective product manufactured in a manner consistent with full-scale production. In the case of military aircraft, pressures prevail to minimize the time from full-scale aircraft development go-ahead to production delivery for operational service. The second goal is to reduce overall system cost, consistent with achieving performance requirements. Both of these goals promote the use of conservative practices during design; however, the first goal (compression of the development cycle) also frequently fosters the need for costly product modifications during later stages of the life cycle.

Experience with military aircraft and other systems reveals that, of the total engineering cost (i.e., all except operational costs) over the system life cycle, less than 10 percent is spent on design, more but still less than 25 percent is incurred in manufacture, and the major expense by far—more than 65 percent—results from required product support such as maintenance and modifications. It is also widely recognized that opportunities for cost reductions decrease (and the cost for modifications increases) rapidly as the system matures—i.e., as design and manufacturing processes and procedures are finalized (Figure 1-1).

The two goals, reduced development time and lowered overall cost, require improved information quality and information management throughout the life cycle, taken in this study as extending from design through field support. This is particularly important during the design phase so that more issues can be considered and analyzed, trade-off studies performed, and design compatibility with subsequent manufacture and product support achieved.

This requires providing the designer complete information about the product, its anticipated service performance envelope and environment, and capabilities and limitations of production and maintenance. This information should be sufficiently comprehensive to cover the life cycle of the product in a design-usable context. Ideally, with such information, an engineering strategy could be developed to yield specific desired benefits—for example, lowest initial cost, lowest maintenance costs, and lowest life-cycle costs. This last option has been termed unified life-cycle engineering (ULCE) and is the subject of this report.



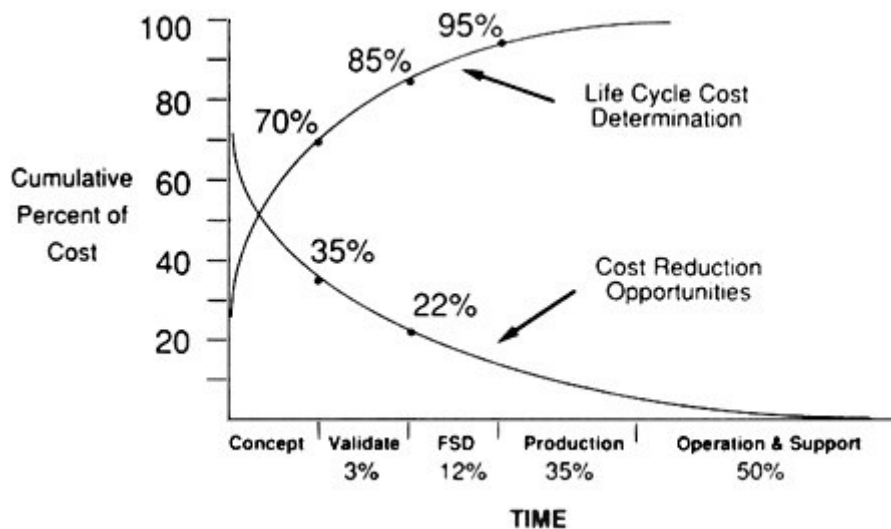

Figure 1-1 Early design determines life-cycle cost.  
Source: Ashton, presentation to committee.

The ULCE concept is consistent with recent Department of Defense (DOD) initiatives in Total Quality Management (Costello, 1988) and Computer-Aided Acquisition and Logistics Support (CALS). These efforts are aimed at the similar objectives of improving the overall life-cycle performance of weapons systems. The term concurrent engineering has become widely used in the government and industry to describe the inclusion of issues such as producibility and supportability early on in the design process. Various techniques including Taguchi Methods (Kackar, 1985), Quality Function Deployment (QFD) (Hauser and Clausing, 1988; King, 1987) and Boothroyd-Dewhurst Design for Manufacture and Assembly (Boothroyd and Dewhurst, 1988) are increasingly employed to improve the design process. These existing methods are not in themselves capable of meeting the technical challenges encountered in achieving an ULCE environment.

### OBJECTIVE

The objective of the study was to identify enabling technologies underpinning ULCE, their readiness for application, and key research and development needed to make them commercially available in a 10-year time frame. This study investigated the status and interplay of various engineering functions employed over the life cycle of weapons systems to meet the goals more successfully than is done at present. Technology needs and opportunities to promote ULCE for a specific class of applications—advanced structural components, typical of those employed in high performance aircraft, requiring extremely high reliability and made in small quantities (fewer than 1000)—were examined.

The study was undertaken in response to a DOD request to investigate the enabling technologies required to provide a unified life-cycle engineering environment for structural components. The committee has taken a broad interpretation of the definition of ULCE to include those manufacturing and support processes that accompany product design as well as information quality and flow to support these processes.

The committee aimed at identifying a generic approach and the enabling technologies needed to make this approach realizable within 10 to 20 years. To check the validity of the findings for components made of well-characterized versus emerging classes of materials, the relevance of the generic approach was evaluated by applying the results to two specific cases: a metal disk for the turbine section of jet engines ([Appendix A](#)) and fiber-reinforced polymer composites in primary fuselage applications ([Appendix B](#)). The committee focused on technical or engineering aspects of ULCE, in contrast to procurement or human-factors issues and directed its attention to weapons systems having the following characteristics:

- Components that perform a structural role (as contrasted to electronic functions); and
- Products that will be manufactured in small quantities (fewer than 1000), where mass-production methods may not be applicable.

### APPROACH

The committee report was developed using the sequence shown in [Figure 1-2](#). Each segment of the process was examined in detail.

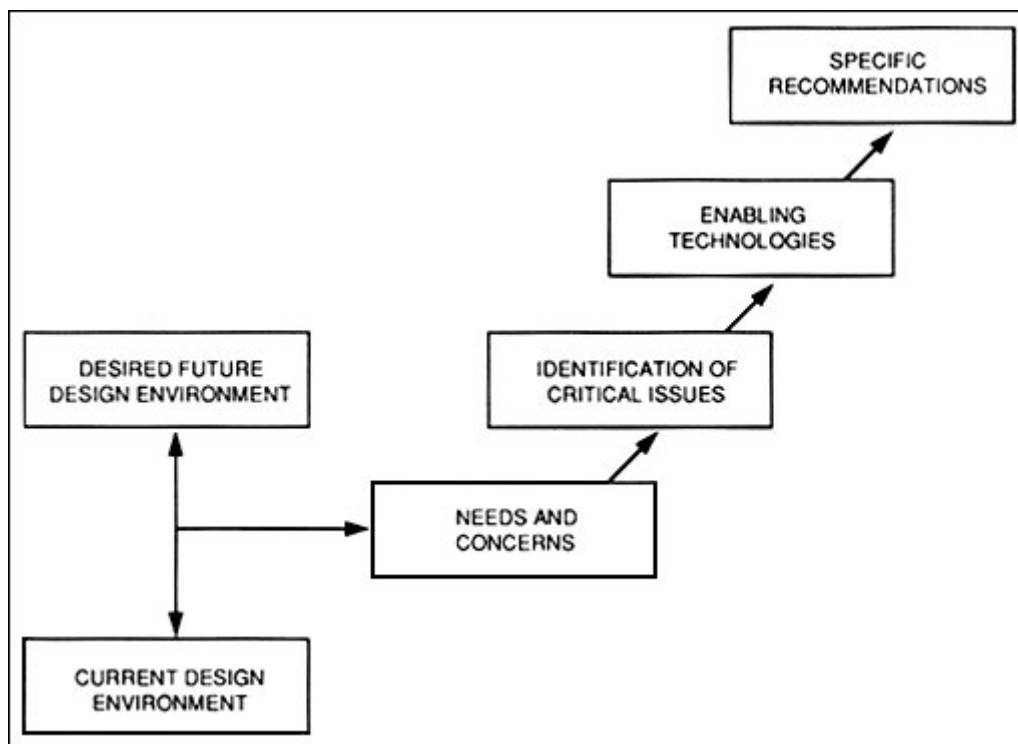

Figure 1-2 Sequence used by committee for this study program.

The following items were the primary issues addressed by the committee in its deliberations to arrive at some specific recommendations for future actions:

About this PDF file: This new digital representation of the original work has been recomposed from XML files created from the original paper book, not from the original typesetting files. Page breaks are true to the original; line lengths, word breaks, heading styles, and other typesetting-specific formatting, however, cannot be retained, and some typographic errors may have been accidentally inserted. Please use the print version of this publication as the authoritative version for attribution.

- Identification of current and desired future environments for producing new engineering systems.

In the initial phase the following five factors were delineated as independent components of ULCE strategy: design, manufacture, product support, materials, and information flow (see [Figure 1-3](#)). For each area, the practices that constitute the present environment of that area were examined. The desired future environment was then determined, representing the technologies, systems, and practices that would make ULCE fully achievable. Chapters 2 through 6 document these environments for the five factors. The committee drew on relevant experience from nondefense products where lifetime ownership and warranty costs have been important to remain competitive. Presentations by individuals from industry, academy, and government were made to the committee; brief summaries of these presentations are shown in [Appendix C](#).

- Development of central needs and concerns and associated enabling technologies for ULCE.

The actual (current) and desired (future) environments were compared. Differences were noted and used to develop a listing of needs and concerns, which were further evaluated to

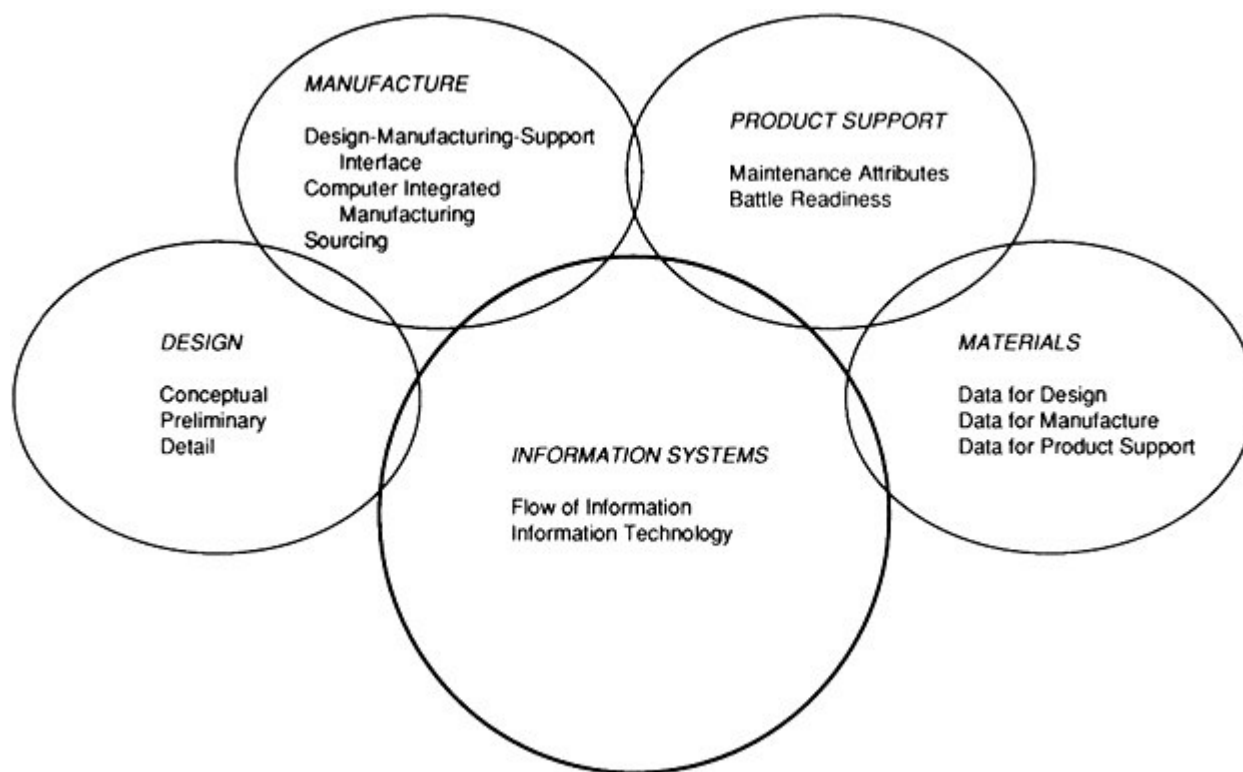

Figure 1-3. Current and future environment.

determine their importance. Important needs and concerns were aggregated into four critical issues, each of which summarizes important problems that need to be resolved for ULCE to be fully implemented. These were the basis for identification of enabling technologies to resolve the needs and concerns. These critical issues are discussed in [Chapter 7](#). The committee used a combination of expert sources, round-table discussion, and vigorous review and re-review to identify, prioritize, and validate the list of enabling technologies required to resolve the critical issues. The "readiness" of the technologies for ULCE was also considered—i.e., whether they are commercially available now, are mature and ready for commercial deployment, are mature but require some redirection or refocus for ULCE, or need fundamental research.

- Formulation of an integrated strategy and set of specific recommendations for the enabling technologies.

Given the differences in readiness of some of these technologies, the committee developed a time-phased plan to bring them to fruition. The recommendations propose a discrete set of actions to promote selected aspects of the enabling technologies. In addition, examples of research and development (R&D) programs that would implement the recommendations are suggested. This information is given in [Chapter 8](#).

### UNIFIED LIFE-CYCLE ENGINEERING

Two prerequisites that are key to successful ULCE are information quality and information flow at critical junctures during the life cycle of the product. The goal of ULCE must be to provide the information at the inception of design or as close to this as possible, since successful life-cycle engineering requires that all phases of a product's creation and existence be considered when it is designed. Considerations that are before a designer involve the producibility of the item (in quantity and with process and materials variability), the usability of the system (within and sometimes beyond the margin specified for the operating envelope), and the reliability and repairability of the product (again within and beyond the specified domain).

At present, major information problems include the limited availability of data on manufacturing and support, particularly limitations that are likely to have an impact on the product, and incomplete (or incorrect) specifications of the operating environment in terms of quantitative engineering property requirements. Even when manufacturing and support information is available during design, its quality may be viewed with suspicion because it may be incomplete or have errors; is based on a small sample of observations; or is framed in an unfamiliar context. This lack of confidence in the quality of information significantly reduces its effectiveness and its impact on the design of products.

Information management in ULCE will draw heavily on computer capabilities for processing, storing, and distributing information across functional and geographic boundaries. A key concept for the implementation of life-cycle engineering is that of providing designers with access to new knowledge and information along with powerful tools to manipulate that information. This new capability will significantly enhance a designer's ability to produce the best possible design given all the goals and constraints that must be considered. Computers also will assist in implementing the practices and policies deemed necessary to ensure producibility in manufacturing and supportability in the field by providing information repository services for managing information derived from many sources and used by many users.

There are four barriers to the implementation of ULCE:

- The traditional serial design process needs to be modified to allow concurrent analysis of the design from multiple paradigms.
- There needs to be a common metric for measuring how good a design is. Alternatives meeting functional requirements must be evaluated in terms of a life-cycle view of the product. Life-cycle cost is probably the best measurement that can be used to compare design alternatives across many functional areas.
- Since improvements in information flow and information quality alone will not necessarily lead to improvements in life-cycle design, there needs to be a translation of information on current products into design rules for future products. This translation of information is viewed as being technically complex as well as difficult to communicate.
- In addition to technical issues, many institutional relationships will need to be changed under ULCE, particularly with regard to the present compartmentalization of design, manufacture, product support, materials, and information flow. These institutional changes will affect vendors, suppliers, purchasers, and users.

### POTENTIAL PAYOFF

There have been numerous analyses of both commercial and DOD products to determine where the true costs of ownership are incurred (Symon and Dangerfield, 1980). The consistent result is that there is an exponential growth in the cost of identifying and repairing a defect as the product matures. Design errors can be fixed quickly and "with the stroke of a (light) pen" during design; their resolution during product manufacture usually requires significant cost, and during product use even greater expense, time, and sometimes compromised performance.

The hypothesis of the committee was that ULCE would make possible correct initial design of a product, process, and support structure. ULCE would improve the quality of products by making it easier to consider explicitly issues such as manufacturability, maintainability, sustainability, inspectability, readiness, and life-cycle cost in addition to the traditional emphasis on cost, schedule, and performance. Although additional resources, time, and expense would be required initially during all of the design phases, total life-cycle costs would be reduced because the resulting designs would provide products with greater overall quality and performance, thus permitting significant reductions in retrofitting and maintenance.

Other gains from the ULCE environment can be anticipated as well. A life-cycle perspective from the designers' vantage point would allow concurrent design processes and thereby reduce the product development cycle time. It would facilitate rapid and efficient response to changes in product functional requirements that inevitably arise during a system's lifetime, and it would enhance the utilization of new technologies.

### CURRENT AND FUTURE ENVIRONMENT

New weapons systems normally are introduced to perform missions that could not be performed previously, and the basis of these systems for military aircraft is application of new technologies to meet flight performance requirements. Typically, several new technologies are introduced at once in support of program objectives. For example, reduced aircraft weight allows

improved maneuverability and greater range. Weight savings can be achieved by designing closer to material capacities, by making more precise structural arrangements for load distribution, and/or by using advanced materials that yield better ratios of strength or stiffness to weight or, more typically by a combination of approaches. More rigorous design will demand more reliable manufacture and product support protocols. Improved information flow (both "feed-forward" and "feed-back") among the functions of design, manufacture, and product support will need to accompany the more sophisticated approaches to these functions.

It is reasonable to assume that program budgets for future systems will be more restrictive and that fixed-price contracting will become the standard business process. Long-term warranties on serviceability, reliability, and supportability will also be required. Shorter development times may be anticipated in the future to be more responsive to enemy threats and to reduce the initial program cost.

Figure 1-1 shows the rapid decay of life-cycle cost reduction opportunities early in the product's life cycle. This decay will continue in the future; a majority of the decisions affecting life-cycle performance and cost will be made well before release to production. Therefore, the future ULCE environment will fully acknowledge this phenomenon and will provide knowledge and tools to be available in the design phase to assess life-cycle parameters. As total life-cycle costs are reduced, the proportions will shift to permit increased effort during design.

Of the many changes to be expected in the future ULCE environment compared with the current situation, one feature will stand out: most activities in design, manufacture, and product support that are performed sequentially and independently today will be conducted concurrently and interactively in the future. Information flow today can be characterized as predominantly one-way: from design to manufacturing to product support. Design is a hierarchical process passing consecutively through conceptual, preliminary, and detailed design steps. Different teams and procedures are involved in each step. The overall process extends over several years and hence through numerous personnel changes.

The initial design process considers manufacturing only informally. The transition to the factory floor consists of a series of steps from concept through demonstration, validation, full-scale development, and finally production, with a more formal link to design as production nears. Automation is not widely applied to processing, inspection, or assembly activities in industry today. Quality assurance often focuses on post-production inspection. Design and manufacturing attributes that make for difficult product support situations are compensated for by more sophisticated field-testing and maintenance resources or by replacing entire assemblies rather than repairing components. Finally, design, manufacturing, and product support cannot directly incorporate correlations to processing, structure, and properties developed in laboratory research on materials.

In the future, the serial design process will be replaced by concurrent processes by providing interactive access for many disciplines (reliability, supportability, manufacturing, etc.) to the design definitions as they are developed. This concurrency will shorten developmental cycles. This, along with improved information systems, will permit a complete audit trail of decisions and authorizations. Products will be designed and represented using features rather than dimensions. It will be possible to evaluate the robustness of a design in expanded operating envelopes, considering variability in manufacturing, materials, and operation.

From early in the design cycle engineering will be able to continually analyze the impact of the proposed advanced materials, manufacturing and support processes and control that are critical in state-of-the-art products. Manufacturing will be an integral part of a product resource



planning and control system that will link it to design, vendors, quality assurance and field service operations and will provide flexible and effective real-time status, automatic data capture, and process control. Failures and maintenance actions gathered from field experience will be interpreted in "design guides," which will assist in reducing the overall logistics requirements and guide future designs.

### VALIDITY OF STUDY FINDINGS FOR OTHER PRODUCTS

While the committee focused on high reliability and low-volume production of structural components many of the current and future environmental conditions appear to be applicable to structural and nonstructural parts and assemblies in general rather than just airframe structures and propulsion systems. The needs and concerns are also usually valid for these general classes of applications. The enabling technologies are particularly focused on the structural components, and, although some are quite general, the set constitutes a more specific view. The recommendations are also focused on structural components, with some further recommendations limited to military systems. However, much of this report could be applied more broadly.

### REFERENCES

- Air Force Systems Command. 1987. Implementation Plan for Unified Life Cycle Engineering (ULCE), March.
- Boothroyd, G. and P. Dewhurst. 1988. Product Design for Manufacture and Assembly, *Manufacturing Engineering*, Vol. 100, No. 4, pp. 42-46.
- Costello, Robert B. 1988. "Implementation of Total Quality Management in DOD Acquisition," Memorandum for Secretaries of the Military Departments, Undersecretary of Defense, Acquisition, 19 August.
- Darilek, R. E., E. M. Cesar, J. A. Dewar, G. P. Gould, and E. D. Harris. 1987. "Surveying Relevant Emerging Technologies for the Army of the Future. Lessons from Forecast II." July, Rand Corp., Santa Monica, CA (AD-A213821/2/XAB).
- Goldstein, G. 1989. Integrating Product and Process Design, *Mechanical Engineering*, April.
- Hauser, John R., and Don Clausing. 1988. "The House of Quality," *Harvard Business Review*, Vo. 66, No. 3, p. 63.
- Jacobs, G. 1980. Designing for improved value. *Engineering*, Vo. 220, p. 178.
- Kackar, Raghu N. 1985. "Off-line Quality Control, Parameter Design, and the Taguchi Method," *Journal of Quality Technology*, Vo. 17, No. 4, 176.
- King, Bob. 1987. Better Designs in Half the Time, GOAL/QPC.
- Symon, R. J. and K. J. Dangerfield. 1980. The Application of Design to Cost as Rolls-Royce, Proceedings of a conference on "The Application of Design to Cost and Life Cycle Cost to Aircraft Engines," May. AGARD-LS-10F. ISBN: 92-835-0265-5.

## 2

# DESIGN

### CURRENT ENVIRONMENT

Design is a hierarchical process that normally extends over a period of several years, through several phases and numerous personnel changes, and is performed in a team environment. All engineered products pass through the sequential steps of conceptual design, preliminary design and final detailed design, although the time spans and value weights depend on the class of product. Similar hardware and software tools, data forms, design considerations, and design processes apply to all these products.

#### Conceptual Design

The first step in design involves broad system concepts and is often referred to as the conceptual phase (Raymer, 1989). It begins with an indication by a customer (in the examples used here, the Air Force) that a new product is needed. Interested and qualified industrial firms work with the customer to establish whether the needs can be met. These usually are defined in broad terms of vehicle type (e.g., fighter, bomber, transport, trainer) and other broad figures of merit, such as gross weight, unit cost, initial production schedule, general flight performance parameters, force-structure mix, operational threat environment, and total program costs. At conceptual design time, the desired performance parameters (e.g., weight, size, fuel use) are only loosely defined. Producibility parameters (e.g., testability, process stability) are even less well defined, and supportability parameters (reliability and repairability) are least defined.

In the conceptual phase, engineers and managers perform studies showing one or more configurations that meet the customer's objectives. Operations analysis techniques are used to project mission effectiveness, vehicle cost, program costs, and other factors. In this phase, decisions are made that will have major impact on the ultimate production costs and supportability characteristics.

Computer tools are invaluable in this phase. They provide methods to define external surface geometry and analytical capabilities to compute automatically important geometric parameters for flight performance analyses. Associated procedures are available for weight and balance, fuel volumes, preliminary lift and drag, and performance analyses. Unfortunately, these computer procedures are not compatible with those used later in the final detailed design stage. In



particular, the procedures used early in the design process are insufficiently accurate to support automated numerical control hardware manufacturing methods.

### Preliminary Design

In the next design phase the customer prepares detailed requirements that are highly refined from the earlier needs and often altered substantially, based on evaluation of the conceptual design(s) and evolving changes in enemy threats, economics, and politics. The requirements are voluminous and may stipulate firm fixed-price proposals with detailed schedules.

At this stage many of the long-term production, operational, and supportability features of the vehicle are established. Final definitions are made of the specific materials and their distribution. Structural arrangements are described for all major structural members, and construction details (e.g., honeycomb, stiffened structure, corrugations, monocoque) and major manufacturing processes are defined.

Many sophisticated tools and methods are utilized during the preliminary design phase. Finite element models are employed for general sizing of structural members and computerized design synthesis methods are used throughout to establish the best structural arrangements and material selections for lowest weight. However, despite the impact on life cycle costs associated with this stage, the ability to view the design from a life-cycle perspective is limited because there are not widely available tools for assessment of life-cycle costs from the preliminary design.

The engineering team in this phase, although substantial in number (e.g., 200 or more during the later stages), is still just a core team that ultimately executes the final detail design. The design team is normally composed of a mix of professional preliminary design engineers (with little or no hardware experience) and experienced design and analytical personnel.

Producibility and serviceability are addressed based on the knowledge of the team supplemented by the advice and critiques from and consultations with producibility and maintainability-reliability experts. Frequently, however, these attributes are included in the design based primarily on the knowledge gained by informal means by the design engineers. While computer-aided design assistance is generally available it supports only geometric definitions and finite element models (FEMs) are not interactive with these design tools. Further, force and load inputs to the FEMs for the airframe must be estimated because of the lack of dynamic analysis models.

Dynamic analysis of electromechanical and hydraulic systems requires the construction of a formal mathematical representation; (e.g., a system of differential equations) followed by a tedious sequence of programming and analysis steps to obtain a solution to the equations. Bond graph techniques (Rosenberg and Karnopp, 1983) are now mature enough to allow a designer to represent a dynamic system without recourse to complex mathematical notation; however, bond graph applications software is only available from academic institutions and is not capable of handling complex industrial systems.

None of the available modeling packages is capable of analyzing the design in the presence of variability due to manufacturing, use, or service; data on production or service operations is not available on computer. Three-dimensional solid modeling techniques are increasingly being used as this technology matures (Bradford, 1988).

Damage threats are considered throughout the preliminary design process and materials and construction methods are selected with regard to perils from maintenance, foreign-object

damage, and enemy actions, but not in a rigorous manner. The specific vulnerability of structures to threats is not well understood, especially with new materials. Also, the threats are not clearly defined enough to allow mathematical simulations.

### Detailed Design

Detailed design is the third major phase in the design process. It usually begins with the "freeze" of the configuration and a general definition of the entire product. A major expansion in personnel is associated with this phase, as is a transfer of responsibilities to a fully integrated functional engineering organization. In the structural areas, teams are divided into separate groups for major components, such as empennage, wing, body (or fuselage), landing gears, and control surface. Each group may include 10 to 50 designers, with corresponding analytical groups for stress analysis, fatigue and fracture, static loads, service loads, flutter, and dynamics. The design engineering groups create the design and coordinate the execution by interaction with the associated analytical groups and other specialist functions responsible for producibility, material technology, maintainability reliability, equipment design, routing of systems, and others.

The supporting methods for detailed design are similar to those of the preliminary design process but are more refined. The designer is responsible for executing the design and obtaining approvals from 10 or more analysts and specialists. The primary objectives for each part are scheduled completion, design hours, weight, and strength (fatigue, static, and dynamic). Producibility and supportability are important and are analyzed by their respective specialists, but neither specific requirements nor audits are generally required.

The current generation of computer-aided design (CAD) or computer-aided engineering (CAE) tools have limited embedded data or parameters to facilitate analysis of production costs and maintenance or spares requirements. They are typically not interactive to the same extent as, for example, FEM analysis. Three-dimensional and solid modeling software is computer-intensive, and current processors are inadequate. Too much information is required to completely represent the geometric and manufacturing descriptions. Except for strength or weight, audit trails of the decisions made during the design process are unavailable. Furthermore, the designer has no CAE access to background data from other programs regarding producibility and supportability. The designer utilizes the best knowledge accessible from the lead engineers and specialists through an informal consulting process. The designer does have the option, as time and initiative permit, to perform trade-off studies to support the decisions. But, in the absence of quantifiable, computer-accessible data, these trade-off studies can not assure optimized design.

The current design methodology for structural components is based on a geometric definition. The manufacturing and support features are derived from the geometry. This method contrasts sharply with the design of integrated circuits, where the functionality (e.g., logic gates) of the design is defined by the designer and the geometry is generated by a computer from the functional definition.

In summary, the current design environment is not significantly different from that in the early days of the aerospace industry, with the exception of computerized assistance for geometry definition and static analysis methods. Computers have been incorporated to perform highly detailed stress analyses of total structures, thereby greatly improving the weight efficiency of resulting design. Computer graphics methods have replaced manual drawing methods and have led to major improvements in accuracy of part definitions. However, as with computer design and analysis, these methods are not integrated and interactive, and they do not include access to historical data or provide audit trails of design decisions on producibility, damage resistance,

maintenance, repair, initial costs, or life-cycle costs. Also, the methods do not permit analysis of stochastic parameters.

After completion of preliminary design, current design assessment capabilities require the manufacture and flight evaluation of one or two prototype vehicles prior to commitment for production engineering and manufacture. The process and available tools to do this job are unchanged from the normal detailed design phase. The value of this phase is not entirely clear, in that it rarely provides the time and funding to answer all the questions. However, it does establish the general flying qualities of the vehicle and does build up a confidence that the new technologies being introduced perform in the predicted manner. If ULCE can be advanced to the point where there is enough confidence in the ability to accurately predict performance of the product, then a prototype will not be necessary.

### FUTURE ENVIRONMENT

In the future engineering design environment, the design process will include the same general components as the past and present, but many activities will operate concurrently. The three phases of design will continue to include the traditional conceptual, preliminary, and detailed design steps. Each design phase in the future will be highly augmented by powerful computer systems and extensive data bases. These will provide data necessary to support decisions and permit interaction between the designer and other disciplines (people, expert systems, information, etc.) to exchange data as required.

Design assessment tools for analysis of the functionality of designs will be readily available. These tools will include capabilities for stochastic analysis of design and manufacturing parameters as well as operating parameters. They will enable designers to analyze performance across multiple energy domains so that an integrated view of the design dynamics will be possible.

The committee believes that future products will be designed and represented using features rather than dimensions. Design rules will be used to create features and fixtures libraries from which designers may select those that meet the functional requirements. Features will be based on demonstrated manufacturability, reliability, and serviceability. The design definition will make automated process planning easy to implement. The preferred method for fabrication along with standard cost and reliability measures will be part of the design base. In addition, the designer will be able to establish relationships among and between components so that the overall view of a part in the system is available. It will also be easier to establish an automatic audit trail of the decisions that were made during design so that the rationale will be available later for an analysis of changes.

In the early design phases, where structural arrangement and internal equipment locations are determined, solid modeling methods will be used to produce highly accurate configuration definitions. Precise external surface geometry will be defined at design initiation. Interactive applications of computerized manufacturing assembly and maintenance operations will be evaluated progressively as the arrangement of structure is defined. At the time of original proposal, and later at the design freeze, computer simulations of all major elements and surfaces will be presented. Evaluations can be made by specialists, management, and customers to verify the completeness and acceptability of all potential hardware elements. A three-dimensional computerized mock-up will be available.

Computerized design optimization methods will be applied throughout the process to derive the best solutions. Using computational fluid dynamics (CFD) and FEMs, aeroelastically

tailored lifting surfaces will be configured that utilize advanced materials. However, the major emphasis of computerized tools will be on analysis of designs for function, manufacturability, and serviceability, not on synthesis of designs. The creative talents of the designer will still provide the design synthesis.

Advanced forms of organic and metal matrix composites will be extensively tailored to obtain the optimum solutions. The detailed design process will include extensive computerized automation to support manufacturing. The work performed by the originating design engineer will greatly exceed that performed in the Current environment. The major portion of the design will be accomplished with solid-or feature-based modeling software that will contain form and feature recognition and process data. Automatic tolerancing, dimensioning, and checking functions will be embedded.

Solid modeling should be sufficiently mature to represent all detail part hardware so that the traditional full-scale metal vehicle mock-up (costing \$20 to \$50 million) will not be required. Solid models of the hardware will also be applied to maintain progressive configuration control with complete data and change records. Individual subsystem elements will be readily interrogated in wide-screen color displays to automatically identify physical interferences or establish minimum clearances.

The designer will have estimates for all the components of life-cycle costs available throughout the design cycle. The cost model will be refined as the design is refined. Computerized audit trails will be required. Each individual part design data set will be accompanied by a design decision record of the basis of each decision as well as the associated trade-off data. All levels of decision can be retrieved for later review. The reasons for material selection, structural concepts, and arrangements can be traced back to the decision based on cost, weight, corrosion resistance, fabricability, damage resistance, etc.

The future design environment will by necessity involve organizational and economic adjustments. Responsibilities for computer mock-ups, design data sets, and geometrically complete and precise original data will lead to more investment prior to design release than in the current environment. Also, computer use will be intensive, requiring memory and computational capacity similar to today's supercomputers. New checks and balances will be required to ensure control of the system, and many of the current downstream checks and reviews will be eliminated. Final engineering release will be unaltered and uninterpreted until part hardware is fabricated and assembled in an automated factory environment. Although engineering costs will probably increase initially because of the additional manufacturing data, within 20 years they may equal current levels of effort with higher combined engineering and manufacturing productivity.

### SIGNIFICANCE OF THE CHANGE

Higher skill levels in using design assessment tools will be required without the current detail skills in programming and mathematical manipulation. The designer will need to be conversant with a broader knowledge domain and with more disciplines. Manual data transfer will be minimized, but there will be a much larger set of information available to be understood, evaluated, and used for decision-making. There will be automated checklists to aid the design process. It is important to recognize that these improved tools heighten the importance of the designers contribution. The skill and the creativity of the individual designer and the design team will continue to determine the success or failure (now measured for the life cycle) of a project.

### REFERENCES

- Bradford, David. 1988. "Through the Labyrinth of Solids Modeling," *Mechanical Engineering* Vo. 110, No. 3.
- Raymer, Daniel P. 1989. *Aircraft design: A conceptual Approach*, American Institute of Aeronautics and Astronautics Inc., Washington, DC.
- Rosenberg, R. C., and Dean Karnopp. 1983. *Introduction to Physical System Dynamics*. New York: McGraw-Hill.

### 3

## MANUFACTURING

### CURRENT ENVIRONMENT

Manufacturing currently is informally linked to the initial design process described in [Chapter 2](#). It traditionally starts with only planning and support personnel working with the design community. The transition to the factory floor consists of a series of steps from concept through demonstration, validation, full-scale development, and finally production, with a more formal organizational link to design as production nears. However, as with the design effort, each phase involves shifts in personnel and learning curves for new personnel on the project.

### Manufacturing-Design Interface

Where ULCE concepts are included in the current manufacturing environment, they begin with the interface of the design engineer and the manufacturing engineer during the preliminary design phase of the project at hand. As noted in [Chapter 2](#), however, the computer tools that support the conceptual phases of the design do not have the interface capability or the accuracy necessary for direct use by manufacturing. Computerized cost-estimating tools, design assessment and models of the manufacturing process are not generally available in easy-to-use packages that are integrated with data from other functions in the company.

As the product progresses through its various development phases and enters the initial production design phase, manufacturing value process engineers periodically review the engineering drawings to identify producibility issues and make cost evaluations. Although design engineering considers the design frozen from the manufacturing point of view it is still flexible, since design engineering generally continues to make minor design changes well into production. The series of "minor" revisions can significantly affect manufacturing; long lead-time items on order may have to be changed and process revisions made that could affect costs.

Again, as with the preliminary design phase, the computer tools that support the detailed design phases of the parts technical planning do not have the interface capability or the accuracy necessary for direct use by manufacturing. Cost trade-off studies are initiated by the design team leader to compare costs of alternative fabrication or machining methods based on past experience and process upgrades being developed for production. Producibility issues are handled informally, and significant problems are frequently not highlighted until very late in the



development cycle. Proper development of a defect-free production environment frequently suffers because producibility problems are left to be solved in production.

### **Computer-Integrated Manufacturing**

Automation is generally not now widely applied to inspection and assembly activities in the aircraft industry. Quality assurance activities are focused primarily on inspection after components have been processed. Inadequate effort is directed toward relating statistical manufacturing process capabilities to design requirements, and statistical process capability data are usually not made available to the designer in either a timely manner or in a usable forum. Joints and attachments are difficult to control directly and to test for process defects. Statistical process control is sometimes used to help the manufacturing engineer control the manufacturing process, but more often it is used by the direct labor force for visual display of process performance rather than trend analysis and control.

Progress on computer-integrated manufacturing (CIM) in industry has delivered mixed results—successes, failures, and often unmeasurable effects. It is generally agreed that there is still too much reliance on paper as the communication method in both the design and manufacturing functions. The task of transferring product definition from design to manufacturing with sufficient accuracy to meet the necessary tolerancing and dimensioning requirements of the parts is very difficult. CAE software systems for manufacturing engineering for activities like tool design are emerging but currently are too difficult to adapt and apply, especially by interfacing existing data from the design systems. CAM systems related to machine-tool control to make the components via numerically controlled machines still function for the most part in an off-line fashion. This approach requires skilled parts programmers with extensive shop experience—a very difficult combination of skills to acquire or train people for today. Techniques are emerging to model manufacturing processes to improve yield, material flow, and product quality. Manufacturing engineers are, however, just beginning to use computer capabilities to assist in process planning, tool management, proactive quality control, and automatic data acquisition and testing.

### **Sourcing**

Most products are manufactured by the same company that designed them. However, weapons systems generally involve many subcontractors and a multi-tiered vendor base. This requires extensive, accurate, and timely communications based on compatible computer information systems for both internal and external communications; such systems are just starting to emerge. Electronic data interchange (EDI) standards are beginning to be effective, at least in administrative areas like traffic and accounts payable and receivable. The manufacturing environment today uses computer assistance for very focused detail efforts or large-volume data processing. Integration with the design function, major weapon systems integrator, and subcontractors is minimal, requiring backup procedures for historical data and audit trails. There is a real "islands of automation" situation in information processing for manufacturing today.

### **FUTURE ENVIRONMENT**

In the future, manufacturing will be an integral part of a product resource planning and control system, linking design, manufacturing, quality, vendors, assembly, and field service operations. This system will be the foundation for the implementation of real-time, two-way

information flow. Computer-based technology will provide the foundation for the efficient small-lot manufacturing so essential to the aerospace industry.

### **Design-Manufacturing-Support Interface**

Early and continually in the design cycle, engineering will be able to analyze the impact of proposed new materials and processes that are critical in state-of-the-art products. The basis of this analysis will be a mathematically accurate, solid-model-based, feature-driven definition of the required parts. The technically complete definition will be easy for the designer to use and to communicate with production and outside suppliers. This concept will be the basis for a true "art-to-part" system, with greatly reduced total cycle time to market a product incorporating design for performance, quality produced to the required cost and schedule, and effective support in the field. Factories will need fast and accurate transfer of all necessary data from the engineering function to make the part.

Linking the design and manufacturing functions will be a unified manufacturing and engineering product definition data base and a corresponding design release and control system. This integrated structure will be the major change in the manufacturing environment and will foster the responsive and automatic flow of design data to manufacturing. This will enable production in a computer-driven, truly flexible network of focused process production facilities consisting of both internal and vendor shops.

Fully computerized audit trails will be incorporated, and decisions on items from material selection to weight constraints will be stored for later retrieval and review. The geometric definition will flow into the fully integrated and computer-based manufacturing process planning system, which will ensure that the correct process and techniques are planned for the part. All required production documentation, from routing sheets through time standards and related job sheets, for all operations, including inspection, will logically flow from the engineering data.

Also included in the overall information flow will be the numerical data necessary to run the automated factory equipment (machining, assembly, and inspection). All of these numerically controlled software routines will be automatically generated directly from the product definition data file. This will include the critical software verification tasks like tool path analysis to ensure producibility clearances and tolerances to design intent. In addition, all numerically controlled machines will be under adaptive control to ensure that the parts are made exactly to specification. Support tools and master models for production tooling, especially in the new materials areas like composites, will also be generated directly from the product definition.

The establishment of a unified and integrated design and production data base will enable manufacturing to have the as-built quality data available for life monitoring and life-cycle analysis by field support. This will be the final link in closing the loop of product monitoring and control via life-cycle engineering principles all the way through the life of the product.

### **Computer-Integrated Manufacturing**

The key computer technology applications within manufacturing will be flexible and effective real-time status, automatic data capture, and real-time process control. Each focused plant will have increased process integration using automated material-handling systems. Tied into the process flow will be automated nondestructive evaluation (NDE). In contrast to today's experience new NDE techniques will quickly catch both product discrepancies and, more



importantly, will identify any adverse process performance trends before product specification limits are reached. NDE will be an integral part of the manufacturing process rather than being used solely in post-process audits, as is generally the current practice. The result will be continuous process capability analysis, which in turn can guide process performance improvements.

Manufacturing will finally be given the tools necessary to run the plant in a controlled, continuous flow. Finite scheduling will be possible that will control all critical shop resources: material, tool, fixture, part programming, human resource by skill, etc. The real advantage will be the highlighting of all waste—which in the total quality view includes any nonproductive step, effect, or delay—in a timely fashion so that the process can be remedied immediately. In the area of critical and complex processes, the advanced sensor data capture and analysis capabilities will allow fast, precise process capability and performance analysis studies. This will cause a fundamental switch in the maintenance of manufacturing resources from preventive maintenance to predictive maintenance.

Factories will be able to produce efficiently small lot sizes approaching a batch size of one via computer-based scheduling and dispatching systems that will be flexible and responsive. They will meet the real need of the manufacturing enterprise on the shop floor. The emerging concept of integrating simulation, emulation, and expert systems will allow truly flexible scheduling systems that will match the flexible manufacturing environment.

### Sourcing

Product component sourcing will be based on process technologies and on group technology coding. The individual components required for a product (or subproduct) will be produced in specially designed factories and will feed the final assembly steps at a pace equal to the product flow rate. This method of logistics planning and control is sometimes called continuous flow manufacturing (CFM) or just-in-time (JIT) replenishment. Advanced computer-based simulation will highlight both physical barriers and bottlenecks at various states of automation, based on either a real or proposed production plan. The availability of costing data from the cell operating in various stages of automation will be a valuable byproduct of future simulations.

Sourcing decisions will favor retaining leading-edge process technologies for competitive advantage in flexible, efficient automated factories. Where the design exceeds the constraints and capabilities of the automated cell, a quick and early producibility alert will be signaled. This will allow for a timely analysis of the option to change the design, increase the flexibility, or change the capability of the cell prior to release for production.

### SIGNIFICANCE OF THE CHANGE

In the future, most factory and office workstations will be directly connected to an integrated computer environment. All nodes in the automated system will either supply control or guidance to the process directly and/or receive information and status. This integration will foster a major change in the outlook of manufacturing engineers and require modification of training of future manufacturing engineers. There will be two new main thrusts. The first will be to expand the concepts of process analysis and process dynamics, emphasizing total systems rather than components and production engineers will need to participate with their counterparts in design in the initial process of product concept, embodiment, and choice of material, leading to the

consideration of method of manufacture. Tasks will extend to cover maintainability by field support, with all the implications for logistics, service, and repair. The second thrust will be to emphasize team aspects of project management and economic considerations that greatly influence successful manufacturing projects.

About this PDF file: This new digital representation of the original work has been recomposed from XML files created from the original paper book, not from the original typesetting files. Page breaks are true to the original; line lengths, word breaks, heading styles, and other typesetting-specific formatting, however, cannot be retained, and some typographic errors may have been accidentally inserted. Please use the print version of this publication as the authoritative version for attribution.

## 4

# PRODUCT SUPPORT

As noted in [Chapter 1](#), product support costs greatly exceed those for design and manufacture. Not unexpectedly, lowering support costs (a peacetime issue) is a key driver for changing the way prime equipment and support resources must be designed for the future. Battle readiness (effectiveness and availability) is the critical issue, however. Any change in support operations must first address the wartime environment and balance that with peacetime considerations.

### CURRENT ENVIRONMENT

The user's responsibility for product support begins in the conceptual phases with the formulation of a maintenance strategy and is formalized as part of the contractual requirements. These requirements range from specifications for design attributes that support the maintenance concept to specifications for the design and acquisition of support resources for implementation of the concept. Once fielded, the user operates and maintains the product with the support resources. These resources include support equipment, spare parts, repair material, trained personnel, maintenance instructions and aids, and repair facilities.

Maintenance techniques and resources may differ for the various categories of equipment (e.g., electronics, hydraulics, propulsion, structures). Yet they share a common objective: specification of product support in advance of product design. Although product support effectiveness depends directly on design attributes, inadequate attention is given these issues in contemporary equipment acquisition. Support considerations are equally critical for prime equipment and support equipment.

### Maintenance Attributes

At present, maintenance resources are planned, designed, and acquired to fit the as-built weapons systems. Design attributes that make for difficult maintenance situations are compensated for by more sophisticated maintenance resources, including highly skilled maintenance technicians using complex instructions. Another way of compensating for difficulty is to remove and replace entire assemblies containing failed or damaged items, rather than attempt to repair them.

Maintenance attributes may be divided into three major classes:

- Reliability—this determines how often the action is required.
- Repairability—this denotes the ease and speed with which an item can be mended.
- Fault isolation—this determines the ease with which a malfunction can be determined, located, and accessed.

As long as present mechanical design and manufacturing processes use tried and proven assembly techniques, repairs to mechanical devices and structures during peacetime will only require conventional mending techniques (e.g., welding, riveting, use of relatively simple adhesives). These are within the present capabilities of the Military Services.

Increasing the reliability of a product—i.e., reducing the frequency of maintenance actions—is the single most important way to improve the support environment. To operate reliably, a component needs to be free of critical defects (from design, material selection, or manufacturing), and it needs to be designed so that it is insensitive (as much as possible) to variation in use and abuse. If it does not fail, resources do not have to be expended to fix it, to provide skills and tools to effect the fix, or to take the item out of service during the fix.

Improving fault isolation, fault location, access, and handling for the repair requires deliberate, special efforts that are not always included in present designs. Difficult repairs, sophisticated maintenance resources, and unnecessary consumption of large assemblies drive support costs to unplanned levels. In addition, high failure rates require large stockpiles of spare parts and repair material at repair sites, whether these are combat units or intermediate-level shops or depots. Peacetime operations allow repairs to take longer than estimated and, if necessary, malfunctioning or damaged items may be returned to the manufacturer for repair. The information needed to estimate these support costs during the design process is not available.

As discussed earlier, mechanical and structural design is advancing rapidly. New materials such as advanced composites and new material processes such as microwave and ultrasonic bonding will require either more complex repair procedures or else more consideration in the design process for simplifying maintenance technicians' tasks. However, with few exceptions, present system and equipment specifications do not address support issues during the design process. They invoke design attributes for product support in two distinct ways:

- The first is to actually describe the desired serviceability features in terms that a design engineer can understand. The features are developed from experience with predecessor equipment and from lessons learned by the user and maintainer as well as the extent of the skill and ability of the person preparing the requirements. Examples may be found in the specifying of fasteners, access panels, gauges, warning devices, and specific safety features.
- The second is to impose quantitative measures on certain supportability attributes such as reliability, maintainability, and testability that need translation to design features by a specialist engineer. The translation is required because the metrics are either statistical in nature or sufficiently abstract that a design engineer has difficulty addressing them in the conceptual stages. The specified magnitude of the metrics in turn is usually developed from some similar predecessor equipment.

Both approaches have shortcomings. Lessons-learned feedback is rarely circulated to those who write specifications; consequently, few if any of the reliability, maintainability, and supportability metrics are translated into the specific design attributes. The use of metrics (together with their magnitudes) based on or scaled to predecessor equipment may be expedient for preparing a specification but does not provide a thorough statement of requirements for the planned application and expected life of the equipment. This methodology does not drive the design process to take maximum advantage of state-of-the-art materials and processes to attain major improvements in supportability. There is a very large accumulation of data on the current support environment (repair actions, parts use, labor costs, etc.), but these data have not been transformed into knowledge for use during design.

Knowledge of what is (and is not) currently attainable would allow realistic yet sufficiently stringent supportability metrics to be specified. Stringent requirements would demand attention by the design engineer, who would develop appropriate design features; yet this procedure does not occur. There are proprietary studies from nondefense industries that clearly demonstrate that designers can design according to supportability requirements if they are provided.

Field data systems are intended to provide information to support labor and cost-accounting functions. Transfer of knowledge to designers is not a primary objective. The U.S. Air Force "Blue Team" program attempts to bring support information to the designers by bringing contractor representatives and active-duty support personnel together. The program's shortcomings are that (a) it is too limited because it reaches a very small fraction of the design population and (b) it is too brief to provide in-depth involvement of the participants with tools and maintenance activities. The Air Force is addressing the integration of data needs for support planning under its Computer-aided Acquisition and Logistics System (CALs) management program.

The current practice places the burden of improved product support on the acquisition of more sophisticated support resources to make up for the inadequacies of the prime equipment. Unfortunately, although product support is extremely costly and often wasteful, it may not really jeopardize peacetime operations, where cost and safety are the primary considerations.

### **Battle Readiness**

Postulated battle scenarios include the challenge to fight battles in austere environments at unpredictable geographic locations; these would be nearly impossible to sustain if the support resources had to continue to compensate for prime equipment shortfalls. To cope effectively with such scenarios, maintenance must be performed with minimally skilled maintenance personnel who possess no specialized knowledge concerning the maintenance task, ranging from changing a tire to repairing battle damage. In addition, the inability to locate spares at all strategic locations demands that materials at hand must, to the best of the front-line (e.g., organizational level) team's capability, suffice for emergency maintenance. These same conditions prevent the use of voluminous maintenance manuals. They also demand that correct fault isolation be possible and that damage assessment or imminent failure assessment be made accurately with the skill and equipment at hand. All three maintenance attributes (reliability, repairability, and fault isolation) will need to be improved to meet future demands.

The solution to these problems is complicated with structural components because new materials are placed into use constantly, requiring not only new manufacturing techniques but also new maintenance techniques and tools. Although the behavior of conventional materials under

normal operating stresses is well understood, accurate prediction of failure mechanisms from abnormal sources (for example, maintenance damage, energy weapons) is highly immature, as are remedial actions. The greatest uncertainty is the operating conditions (e.g., turbine disks in the F-100 engine—[Appendix C](#), Stephen Finger presentation), not the understanding and knowledge of how materials fail. The introduction of new materials provides still more unknowns concerning product life and product support. In addition, trade-offs in structural components that favor manufacturing techniques may have a large effect on the maintenance techniques. For example, progressive assembly buildup may simplify construction but requires progressive dismantling to gain access for repair.

### **FUTURE ENVIRONMENT**

The future design environment will require that comprehensive facts regarding operating condition, behavior, failures, and maintenance actions gathered from field experience be interpreted as "design guides" to be used in a design process. The design process (itself changing in the future, as discussed in [Chapter 2](#)) will incorporate the design guides. Also, it will translate accurate and specific design information into automated maintenance aids ranging from built-in test devices (e.g., strain gauges, crack detectors, operability decision circuits) to portable computers containing comprehensive maintenance instructions (to replace clumsy, often incomplete maintenance manuals). The flow of information from support to design will be faster than at present and will be more reliable, complete, and usable. This will be accomplished by automated data capture, transformation, and transmission.

### **SIGNIFICANCE OF THE CHANGE**

Design features to improve the maintenance environment will not only simplify the maintenance tasks but also decrease the number of different skills required to perform maintenance. Properly designed access panels and removal and replacement techniques will reduce both the maintenance time and the dexterity required. Thus, fewer highly skilled maintenance technicians will be required.

## 5

# MATERIALS

### CURRENT ENVIRONMENT

The cost of materials currently contributes only a small fraction to the overall cost of structural components in use in military applications. The cost factor and current rapid advances in materials combine to form a high-leverage item for improving systems performance, maintainability, and supportability. Advances in materials are occurring on a wide front. Composites with either metal, ceramic, or polymer matrices reinforced with a broad spectrum of fibers or particles allow for development and design in an ever-increasing number of applications. Metal alloys with very refined microstructure produced by rapid solidification processing provide enhanced mechanical properties and corrosion resistance, and toughened ceramics are finding uses in high-temperature bearings. The synthesis of new polymers has led to the development of materials with improved mechanical properties and resistance to solvent degradation.

### Materials Data for Design

Validated experimental measurements of materials properties are the materials data most needed by designers. Indeed, the important structure-property correlations derived over the past few decades show that materials properties cannot now be predicted with the accuracy needed for design purposes and even interpolation must be done conservatively. Therefore, larger materials data bases are needed now and will continue to be required in the future (NMAB, 1983). The cost of developing the data for a data base on a new alloy sufficiently detailed to be useful for design is estimated to be upwards of \$100 million. This cost estimate will encourage the continued use of existing alloys rather than new ones offering only minor gains. There have been no results from current efforts to construct a national materials data base.

The materials data needed for design in a life-cycle engineering framework do not now exist for structural applications except for those under the simplest of conditions (e.g., uniaxial tension stress states in an inert environment). The principal reasons for the absence of these data are (a) inadequate specification of service environment, (b) the dependence on inexpensive simple tests rather than multivariable tests with only an approximate conceptual framework to extrapolate from the test conditions to the service conditions, and (c) the duration and high cost of long-term tests (exceeding 25,000 hours).



At present, materials are selected from a list of available alloys, compounds, and composites. Metals are attractive because their parameters have less variability than those of the newer composite materials. In some cases new materials are used in design without adequate experience data to characterize their performance completely. Application of new materials in initial design can be a high-risk, high-payoff (or high-loss) design decision. Variability of material properties produces uncertainties in design, which can result in conservative parameter values being applied.

### **Materials Data for Manufacturing**

Substantially more effort has been devoted to developing structure-property correlations than processing-structure-property correlations. This is partly because it is more difficult to model changes in structure caused by the manufacturing or forming process. Nondestructive evaluation (NDE) is not sufficiently quantitative in characterizing either materials microstructure or defects and needs to be coupled to real-time process control to upgrade product quality and yields.

Experience gained in the laboratory on research of either processing or properties of new materials is often not readily transferrable to materials processing engineers, equipment designers, and manufacturing staff, due to inadequate knowledge of the effects of part and process scale-up and the reduced process control capability of many manufacturing operations. Although "limit" criteria exist for various processing operations, it is not possible in all cases to predict materials properties after single processing sequences, much less those involving multiple operations. To a large extent, material behavior is not sufficiently well understood to allow prediction of mechanical properties or their time-dependence, particularly for complex loading sequences. The time required for "diffusion" of materials experience delays the successful application of advanced materials.

### **Materials for Product Support**

The repair function currently utilizes existing materials processing and joining techniques such as welding, riveting, and adhesive bonding. Damaged parts are often completely replaced. Most of the repair function is done manually. The increasing complexity of materials and joining techniques is putting increased pressure on the maintenance and repair function for greater use of NDE techniques both through in-service monitoring and on a periodic basis during maintenance. Although a substantial part of this inspection process uses manual NDE techniques, automated techniques are being introduced.

Current research in materials science tends to focus on a specific material or class of new materials. Common first principles and unifying theories are only slowly emerging from the research community. Information flow to the materials community from the design, manufacturing, and support communities is weak and irregular.

### **FUTURE ENVIRONMENT**

The driving forces to develop and use advanced materials will continue to be strong in the future. In fact, there are many indications that the pace of advancement will increase. Revolutionary advances will occur in materials technology brought about by a combination of new requirements, computer modeling techniques, and the rapidly expanding knowledge base in

materials science and engineering. Materials will need to be tailored more closely for a wider variety and combination of properties and applications.

The expected emergence of hypervelocity aircraft with orbital capability will create many new materials challenges. These vehicles will require extraordinarily light materials that also possess resistance to high temperatures (3000°F for leading edges and 1500°F for large expanses of primary structure). The requirement for reusability for repeated space missions will lead to new problems not previously encountered for materials used in spacecraft or rocket booster systems; for example, fatigue, repairability, and resistance to runway foreign object damage. Materials of primary interest for these applications will be metal matrix composites, carbon-carbon laminates, and toughened ceramics. For example, composites will provide directional strength and stiffness as well as greater reliability and high-temperature capability than currently available. Reduced density, greater temperature resistance, increased toughness, enhanced repairability, greater damage tolerance, etc., will be designed into materials in various degrees for each unique application. Weight savings of the order of 20 percent over present-day materials are expected.

### Materials Data for Design and Manufacture

Design requirements will continue to drive the materials specifications, but there will be a unifying theory available to estimate the life-cycle properties of a new (developmental) material before testing and physical analysis are complete. The design process will be facilitated by the availability of a common materials property data base. This data base will still be incomplete, especially for advanced composites (metallic, ceramic, and polymeric matrix), and this could retard application of these materials. The development of more powerful models and constitutive equations of materials behavior will compensate for the incomplete data bases to some extent.

Substantial gains in two areas underpinning development of structure-property-processing correlations are occurring now, and more are anticipated in the next 20 years. First is the development of probes based on NDE sensors for characterizing materials during processing in terms of their microstructure, geometry, and chemistry. Second is the development of more sophisticated and realistic models of materials behavior during processing. These areas will make key contributions to the technology base needed for predictive or intelligent processing capabilities.

The revolutionary advances in materials will lead to higher costs for materials and a proportionately greater cost of materials in new systems. Costs will be somewhat controlled and quality greatly enhanced by automating the processing of materials and by automating parts fabrication. In many cases these materials will be custom-designed to provide unique properties tailored to a specific application blurring the distinction between laboratory scale and production processing.

Suppliers will assume a greater responsibility for materials certification. This in turn will require that test methods be developed and agreed on, especially for advanced composites.

Progress in sensors and process models will lead to automated or intelligent processing of materials (Yolken and Mordfin, 1986). This intelligent processing of materials will utilize a feedback system consisting of NDE sensors operating in the framework of a process model and in an expert system that drives the process controls; a valid process data base will be essential. This automation approach, which could be called intelligent processing of materials, will change.

The implementation of intelligent processing of materials will result in improved productivity and quality, increased uniformity of properties, and, if the knowledge base for the expert system were started during the research stage, shorter time from research to application. Intelligent materials processing will also allow for improved scale-up from small batches to larger production runs.

### **Materials in Support**

In the future there will be a need for continuous monitoring techniques for critical components of weapons systems. The NDE equipment will have to be built into the system and for many applications equipment weight reduction will be vital. NDE techniques in current use include ultrasonics, x-ray radiography and tomography, eddy currents, dye penetrants, magnetic particles, and thermography. NDE techniques of the future might include electrical measurements of dielectric materials (ceramics and polymer composites) utilizing microwaves, capacitance probes, direct dielectric measurements with electrodes, and a.c. spectroscopy; nuclear resonance; acoustic emission; neutron techniques; and laser techniques for holography, surface finish, and thermal wave imaging.

Novel new repair techniques will need to be developed for advanced materials, especially for advanced composites. Materials processing utilizing microwaves or ultrasonic bonding might be employed. There will be an increased need for this type of repair as system components become increasingly larger. Partial automation of repairs will also become more common in the future.

### **SIGNIFICANCE OF THE CHANGE**

The emphasis on maximizing performance will continue to foster the development of high-performance materials; however, the need to more completely characterize these materials to assure their suitability over the complete product life cycle will inhibit premature application of new materials. The list of currently available materials is sufficiently lengthy that, even in today's environment, it challenges the ability of the materials engineer to make the most effective material selection. The quantity of empirical data which must be generated to adequately characterize materials in the ULCE environment and the amount of empirical data which must be digested and weighed during materials specification in the ULCE environment is so vast that the empirical approach is clearly impractical. Thus the role of the materials science community must be to develop models or (less satisfactorily) empirical correlations (Ashby, 1989) so that the material data can be made available in compact form. Future research must focus on unifying theories that will permit rapid evaluation and estimation of parameters for new and untested materials. A major requirement will be the capability of predicting material behavior in complex and time-varying load, temperature and chemical environments and the ability to model the interaction between these parameters will be crucial to successful materials design. It will also be necessary to more completely characterize and control manufacturing processes to assure that the material, as fabricated and applied, is well described by the material model used.

### **REFERENCES**

Ashby, M. F. 1989. "On the Engineering Properties of Materials." *Acta Metallurgica* Vol. 37 pp.1273-1293.

National Materials Advisory Board. 1983. NMAB-405, Materials Properties Data Management—Approaches to a Critical National Need, National Academy Press.

Yolken, H. Thomas, and Leonard Mordfin. 1986. Automated processing of advanced materials. ASTM Standardization News. No. 2, p. 4.

About this PDF file: This new digital representation of the original work has been recomposed from XML files created from the original paper book, not from the original typesetting files. Page breaks are true to the original; line lengths, word breaks, heading styles, and other typesetting-specific formatting, however, cannot be retained, and some typographic errors may have been accidentally inserted. Please use the print version of this publication as the authoritative version for attribution.

## 6

# INFORMATION SYSTEMS

## CURRENT ENVIRONMENT

### Flow of Information

Information flow has been characterized as being dominantly a one-way flow: from design to manufacturing to support. In some cases the materials community is not included at all. Life-cycle information flow from manufacturing and support back to the product and process designers is incomplete and slow. Many designers have new assignments before the product passes into manufacturing, and the product life cycles are so long that designers are almost certain to have new assignments before their designs attain maturity. Useful feedback to the designer on manufacturing problems for current products is also limited, as is feedback on current support problems.

At present, the question of manufacturability is a complex, multidisciplinary one. Complete information on the suitability of a product for manufacturing includes costs, conformance to process capabilities, assemblability, fragility, sensitivity to the manufacturing environment, testability, and many more. The designer needs information about each facet of production to ensure an appropriate product design. As mentioned, this information is not generally available in the form of feedback on current similar designs. Also there is an incomplete set of design assessment tools to allow a designer to test the design for manufacturability or for supportability. Integrated Computer-Aided Manufacturing Definition (IDEF) models are becoming the standard for describing information flow requirements for integrated manufacturing systems. This modeling method is expected to attract additional users in the near future. The new emphasis on looking at information flow within a manufacturing enterprise will provide a sound basis for integrating ULCE technologies and practices.

Similarly, the question of supportability is complex and requires information from many disciplines. Designers need to consider cost, reliability, repairability, environmental sensitivity, use beyond the original operating envelopes, etc. Currently, only a limited amount of information can be made available to designers to aid them in making decisions that will enhance the supportability of the product. The best information comes from direct interaction with support personnel, but its utility for new designs is limited. Feedback on failures and repairs is quantitative but without supporting qualitative narrative and item history. Modes of damage and battle threats are not generally communicated from operations back to the designers. Even basic information on use and the operating environment is not fed back to the designers.

It is difficult to notify designers of lessons learned or new alternatives. Often the information to improve designs exists, but it resides in different data bases, with different access methods, and with different contexts for understanding.

Computer-based information systems can be developed which will provide better feedback to designers but other issues related to security and accountability will arise. For example, information security for traditional methods (paper) is reasonably complete, but computer-aided design systems have not yet demonstrated that they can provide appropriate protection. Also, current technologies do not provide audits to ensure that required procedures have been followed and that required approvals have been obtained, especially when information crosses organizational boundaries.

### Information Technology

Current data systems require prohibitive software modifications, incurring high cost and delay, in upgrading to meet new requirements. They reflect current functional and company organizational structures, and in many cases modifications lag and even prevent organizational improvements. They do not easily permit the addition of a new arbitrary data type—e.g., vision data for inspection cannot be added to a numerical-control program file.

The current state of the art in artificial intelligence technology supports one main application area—expert systems. These applications are generally rule-based systems. The rules represent knowledge of the problem domain with which the system is concerned. In general this knowledge is obtained directly from human experts. There are several hundred applications in current use, with a focus on stand-alone manufacturing systems. An Air Force project to develop meta-level knowledge for computer-integrated manufacturing is underway and is coordinated with an object-oriented programming project to improve knowledge-representation capabilities. Rule-based expert systems are beginning to be used to process engineering notes for comparison with design rules. These systems may be used to communicate from design to manufacturing, but there are no general methods for feedback to the rules base to reflect new manufacturing knowledge. The role of artificial intelligence technology in providing advanced design capability has been discussed by many authors (Mostow, 1985; Lakin et al., 1989; Ulrich and Seering, 1988).

The International Graphic Exchange Specification (IGES) is an industry standard for communicating the geometric portion of a design definition, but there is no standard descriptive language for communication of the nongeometric and manufacturing process specifications associated with a design. Electronic communication of design definition is difficult, but several government-initiated information exchange programs provide encouraging progress—Geometric Modeling Application Interface (GMAP), Product Data Definition Interface (PDDI), as well as Department of Defense (DOD) Standards, and American National Standards Institute (ANSI) (14.26M) Electronic Data Interchange.

The U.S. information processing market has supported numerous vendors of computer equipment both large and small. Unfortunately each vendor has chosen to develop systems which are vendor-specific. Hence, current computer applications are not readily transferable to other hardware or operating systems, many depend on a particular data-base manager, and some are dependent on a particular display terminal. However, this is slowly changing. Major computer vendors have announced plans to support applications across a wide variety of operating systems, data base managers, and communications protocols and application architectures are being announced that will allow transfer of applications without major revisions.



Advanced function engineering workstations are available that provide a significant improvement in computer power and graphics display for designers. Research is in progress by the Air Force to investigate the best architectures for parallel processing for ULCE problems. ULCE data exist in hierarchical, relational, inverted, flat files and other data base managers. Relational data base managers are available to link data from multiple paradigms to a common access facility. The Integrated Information Support System (IISS) provides access to data on a heterogeneous collection of data-base managers across a distributed environment. Other current activities that will aid the integration of data from diverse sources include the Integrated Design Support System (IDSS) and the Integrated Manufacturing Data Administration System (IMDAS).

## FUTURE ENVIRONMENT

### Flow of Information

In the future, design systems will include a complete set of design assessment tools and access to current manufacturing and support information on similar designs. There will be a more complete characterization of the production and operating environments, since future products will include embedded sensors that will generate feedback from manufacturing and support to engineering design. Integrated information will be available to designers and support personnel. In the ULCE environment, information on current and predecessor products and processes will be available to designers as they work on new products. Future development cycles may be shorter, so designers will have better opportunities to track their work into production and to obtain firsthand information on manufacturability. The current serial design process will be replaced by concurrent processes by providing interactive access for many disciplines (including reliability, supportability, manufacturing process) to the design definitions as they are developed. Future systems will permit a complete audit trail of decisions and authorizations and, to some extent, will ensure their occurrence.

### Information Technology

Many of the concepts, analysis, and research to support computer-integrated manufacturing (CIM) are part of the elements required for ULCE. Key CIM activities are taking place in Europe under the European Strategic Program for Research and Development in Information Technology (ESPRIT) Computer Integrated Manufacturing Architecture Project, and in the United States at the National Institute of Standards and Technology's Advanced Manufacturing Research Facility. Within the next 5 years the CIM architecture developers will have carried out a first complete pass at developing a generic open system architecture for manufacturing enterprise information. They will have identified the major system objects and will be ready to prepare standards for the International Standards Organization.

In the next 5 years artificial intelligence systems will be extended to include abilities to infer rules from data, improve themselves, monitor and maintain self-consistency, accept and understand human speech, scan and understand unstructured text, and understand and communicate graphics representations. Neural nets may offer an opportunity to understand complex phenomena from experimental data and to supplement missing or faulty data.

Extensions beyond 5 years are difficult to project. In the future, complete standards for electronic exchange of product definitions will be in place. Telecommunications among contractors, vendors, and customers will be commonly used and will include full-motion video facilities. Future data systems will include the ability to add new data types (telemetry, video,



visual images, comments) as necessary to data bases. Conversion tools from current paper methods to digitized records will be available to automate the transition and to establish historical references. Highly improved methods of communication will be employed to transfer design and product quality data among contractor, customer, logistics organizations, vendors, and product users. There will be shared learning across the interfaces of these functions. Data access will be routine across diverse systems, and integrated systems will accommodate natural language, audio, video, and graphics. There will be a generally available data base of materials properties.

Information reference models will be in place to provide definitions for major components of CIM systems. These same models may be able to be modified with minimum effort to include the additional requirements of ULCE.

Future data systems will permit the addition of new data types to existing data bases as the need arises. Research to support this capability will continue during the next 5 years. Finally, there will be coordination and cooperation in the development of ULCE computer systems so that suppliers, contractors, and the government (vendors, manufacturers, and customers) will be able to communicate requirements, commitments, and information across their physical, geographic, and organizational boundaries.

### SIGNIFICANCE OF THE CHANGE

As in CIM, ULCE concepts are based on the availability of unified data access across a manufacturing enterprise, including its suppliers and its customers. Data access in a heterogeneous environment of processors, communications networks, data-base managers, and user contexts without end-user awareness of the complexity of this environment is required. Current research will continue, as will an increased commercial emphasis to reduce research results to practice. Closer ties between research and commercial development will enhance the technology transfer. Additional personnel will become end-users of ULCE systems, and many of the current and future users will need to tailor general solutions to their particular operating environment, plant configurations, changing business and policies, and so on. They will need to accomplish this tailoring without the use of data processing and/or computer science skills that are different from their regular assignments. High-level commands and languages will make this user productivity possible. Software system prototyping will be in widespread use as a software engineering tool.

### REFERENCES

- Lakin, F., J. Wambaugh, L. Leifer, D. Cannon, and C. Sivard. 1989. "The electronic design notebook: performing medium and processing medium," *The Visual Computer*, 5, 214.
- Mostow, Jack. 1985. "Toward Better Models of the Design Process," *AI Magazine*, 6, No 1, 44.
- Ulrich, K. T., and W. P. Seering. 1988. "Function Sharing in Mechanical Design," *Proceedings of the Seventh National Conference on Artificial Intelligence (AAAI-88)*, 342, American Association for Artificial Intelligence.

## 7

# CRITICAL ISSUES

From its study of today's environment covering the extent of unified life-cycle engineering (ULCE) technology and application for structural components—Coupled with predictions of the future environment and potential for ULCE, the committee identified a list of issues raised by comparison of current and future environments. The critical issues are:

- ULCE-driven development of materials processing and repair methodologies requires integration of research and development (R&D) across disciplines.
- Advanced analytical modeling and simulation methods to predict actual component manufacture, operation, and logistics do not exist to the extent required to preclude the need for physical prototypes and mock-ups.
- The information system for an integrated team approach to ULCE is inadequate.
- The ULCE team will need to make key decisions while still operating with incomplete information.

These issues were then distilled and used to develop a set of needs and concerns. The needs and concerns were reviewed to extract the underlying critical issues and are the basis for the committee's recommendations.

The related needs and concerns and their associated critical issue are shown in [Figure 7-1](#). From the needs and concerns a set of enabling technologies needed to address each issue was developed and the enabling technologies and critical issues they support are shown in [Figure 7-2](#).

## VALIDATION

Two case studies were undertaken to evaluate the concerns, one on a metallic turbine disk ([Appendix A](#)); the other on a fiber-reinforced composite horizontal stabilizer ([Appendix B](#)). In

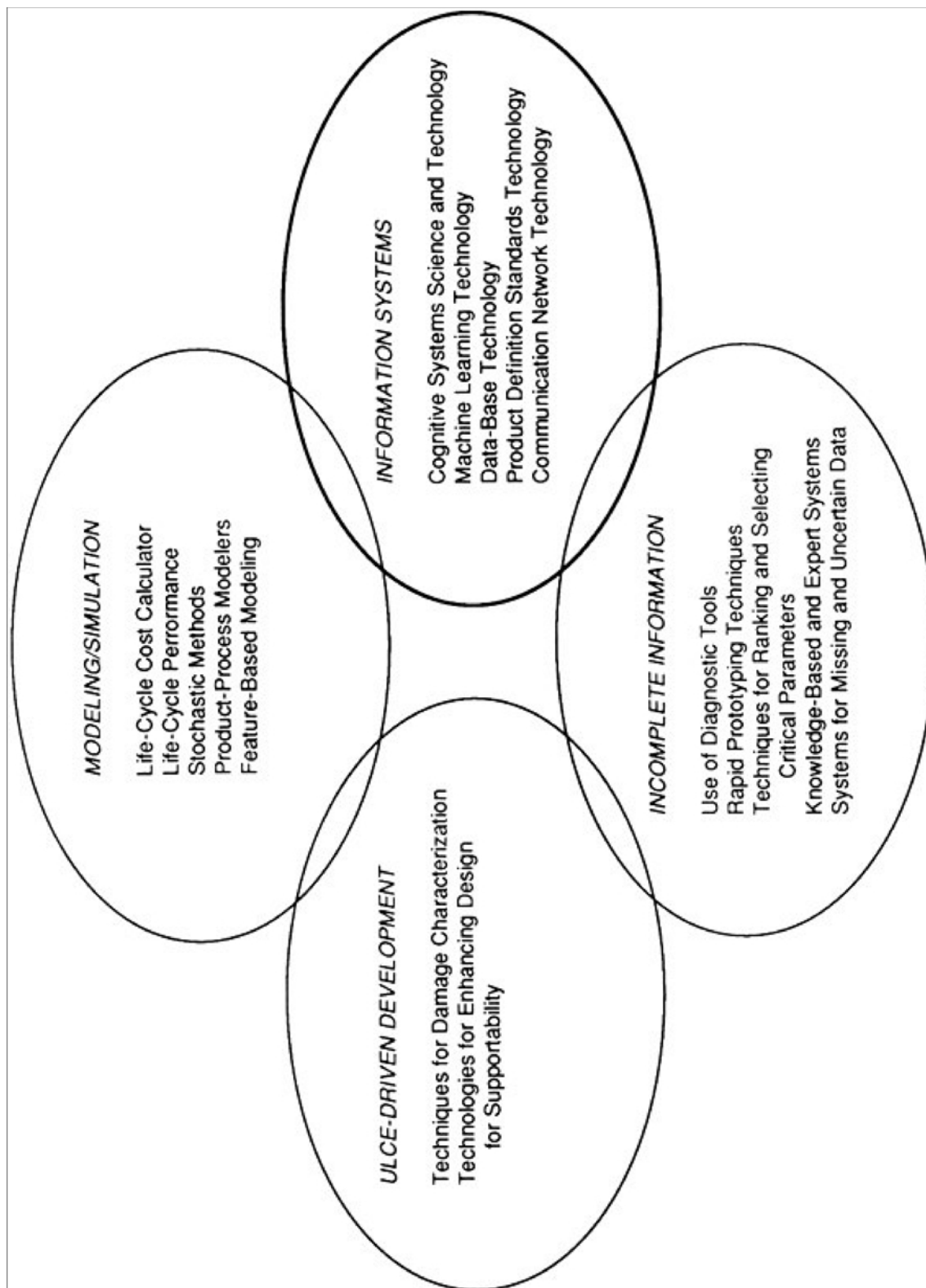

Figure 7-1 Needs and concerns.

About this PDF file: This new digital representation of the original work has been recomposed from XML files created from the original paper book, not from the original typesetting files. Page breaks are true to the original; line lengths, word breaks, heading styles, and other typesetting-specific formatting, however, cannot be retained, and some typographic errors may have been accidentally inserted. Please use the print version of this publication as the authoritative version for attribution.

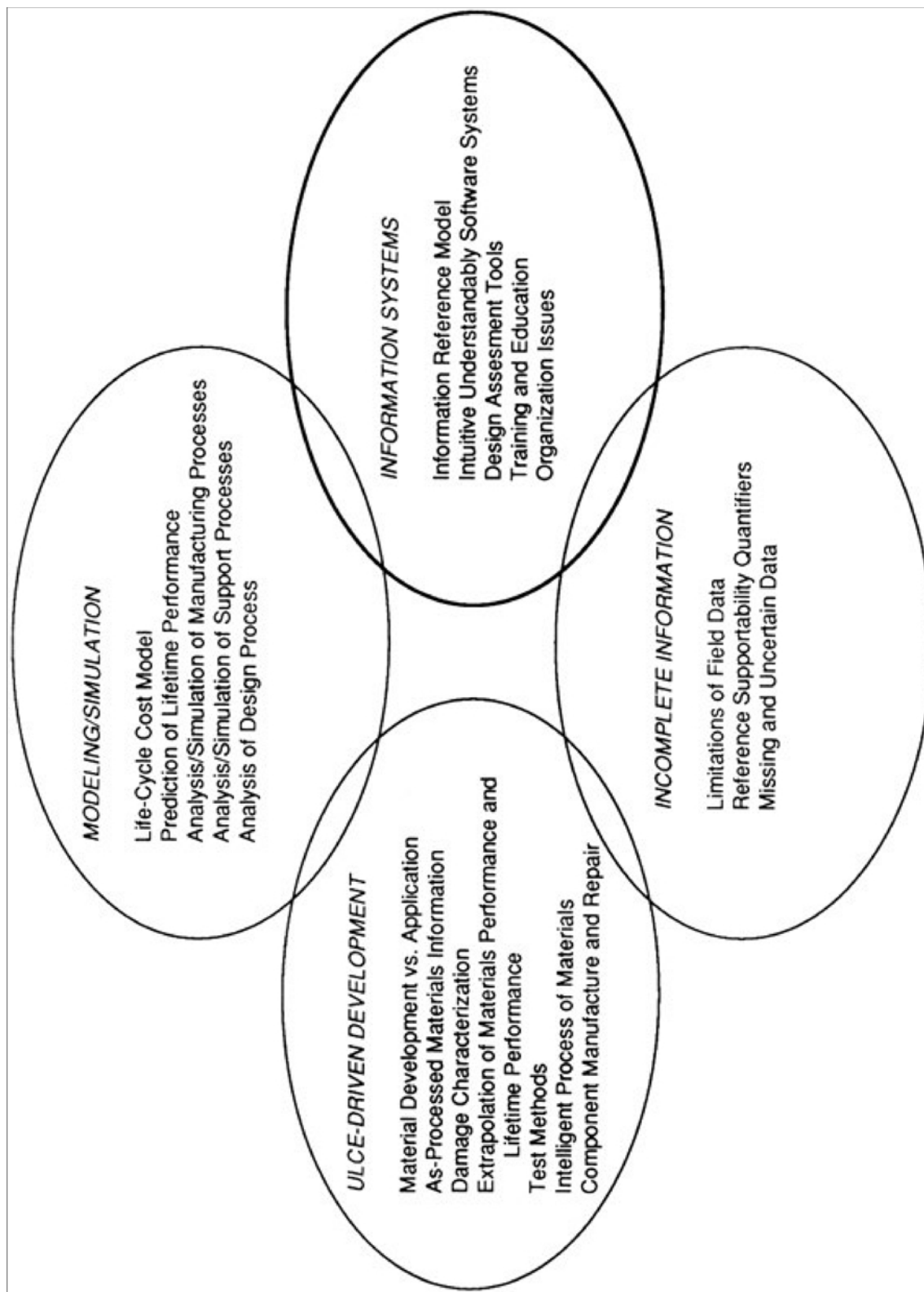

Figure 7-2 Enabling technologies

the case studies it was found that all of the needs and concerns identified by design engineers were associated with at least one of the four critical issues defined by the committee. The comparisons support the validity and completeness of the generic critical issues developed by the committee. Additional insight into the benefits and requirements of the ULCE approach is obtained by understanding the needs and concerns which are the basis for the critical issues and a brief description of each and of the enabling technologies is given in the following section.

## CRITICAL ISSUES 1

ULCE-driven development of materials processing and repair methodologies requires integration of R&D across disciplines.

This issue highlights the integral role of materials science, development, processing, characterization, and engineering in ULCE. Most important is the recognition that knowledge of materials processing and durability strongly affects design decisions. Knowledge of the manufacturing processes and the resulting materials properties is required at design time. Coordination of materials research and development with ULCE design and manufacturing needs is viewed as critical to ULCE implementation.

### Needs and Concerns

#### Material Development Versus Application

The science and development of new materials is progressing rapidly, resulting in a reservoir of materials with potential for significant performance improvement. It is inevitable that many of these materials will be pressed into service before their performance is fully characterized. Complete characterization is extremely difficult because of three factors: incomplete specification of the environment in which the material is to perform; lack of fundamental understanding of materials behavior; and the long testing time necessary to conduct the evaluations.

Even during the initial stages, material under development is targeted for a particular component family of applications (e.g., turbine rotor disk forgings or turbine nozzle flap skins). This often occurs before a specific weapons system application is defined. ULCE needs for component producibility and supportability in the field can, and should, be addressed at this earliest material development stage.

Key technological issues that must be addressed prior to application of materials are discussed in the following sections. However, the overall strategy needed for ULCE to capitalize on gains in materials development is the coordination of materials efforts with design and manufacturing early in the product development cycle.

#### As-Processed Materials Information

The lack of information about product and material variability as processed is a serious concern. To predict the behavior of a material in use, it is necessary that a broad range of material attributes be known; this sometimes requires an exhaustive set of manufacturing data in addition to laboratory data. For many "conventional" materials, information on behavior may be incomplete or difficult to obtain for different application configurations, particularly in sections of very large or small sizes where the alloy microstructure and phase distribution are different from those typically obtained, or for sections (like weldments) having gradients in microstructure.

Thus, structure-property correlations need to be extended to include the effects of processing variations, particularly for components with extraordinary materials microstructure. This information needs to be included in materials data bases. For new materials, particularly ceramics and composites that are very sensitive to defects that may be introduced by manufacturing and processing, the information available is usually sparse and inadequate for design use.

### **Damage Characterization**

The effect of the service environment including temperature, stress, corrosion, embrittling conditions, battle and accidental damage on materials behavior needs to be formulated in a framework usable for ULCE. Understanding of the behavior of conventional metal alloys exposed to simple test conditions (e.g., uniform temperature and stress states giving steady-state deformation) has increased rapidly over the past 3 decades. This knowledge base has allowed formulation of constitutive equations describing observed behavior, and sometimes predicting it. Actual service conditions are far more complicated than these test conditions, particularly when time-varying conditions occur under which the principal modes of damage change over time as well. The dependence of damage by one mode on previous (or subsequent) damage by another mode is not understood in conventional alloys, much less in emerging ceramics and composites. In addition, materials behavior under transient conditions is poorly understood. Of special importance is the transient leading to failure, which is usually controlled by localized nonuniform events. Understanding of the physical nature of damage and its quantitative formulation are needed. While efforts must be devoted to both model development and experimental programs, emphasis should be placed on modeling because of the huge data base needed if it is obtained through empirical testing. For example, creep deformation involves several independent variables such as temperature, stress, frequency, and amplitudes of transients. The modeling recommended would aim toward formulating constitutive equations that combine first-principle results with engineering considerations. The experimental efforts considered necessary are those characterizing the physical nature of damage (e.g., arrays of dislocations, cavities, grain boundaries, and other interfaces). It is necessary to describe not only individual defects but also the statistical or probabilistic nature of their distribution and ultimate influence on properties.

### **Extrapolation of Materials Performance and Lifetime Prediction**

The ability to extrapolate materials performance is imperative, since it will not be possible to develop a data base for all contingencies. The accuracy in extrapolation will depend on successful characterization of the manufacturing process, testing of the as-produced material, analysis of damage accumulated in service, and correct specification of future service conditions.

Extrapolation or life-prediction models will need to extend damage models to include a criterion for incipient failure and termination of service. This extension is nontrivial because, whereas damage occurs initially in a quasi-homogeneous manner throughout the material, failure is normally controlled by a series of localized events that usually occur on a statistical rather than deterministic basis. Therefore, life-prediction models in most cases need to be probabilistic. In addition, as design requirements approach the incipient failure point of the material, nondestructive evaluation (NDE) becomes increasingly important to detect the precursor state of the "critical" defect. This topic is discussed further under the second critical issue on modeling methods.



## Test Methods

Experimental data are needed for various materials science and engineering purposes to assist in understanding fundamental materials behavior and in validating models thereof; to guide the development of advanced engineering alloys and novel materials; and to establish valid data bases for design, manufacture, and product support. A hierarchy of test methods will be useful, with the complexity, cost, and standardization usually being greater for engineering tests than for science tests.

## Intelligent Processing of Materials

Closer control of materials processing is required to obtain reproducibly and reliably the desired material microstructure, component structure, and properties. One approach to achieving this control is termed intelligent materials processing, where sensors, process models, expert systems, and closed-loop controls are brought to bear on specific processing operations. This approach needs to be developed for materials processing in both component manufacture and repair. Improved processing control will also hasten commercial availability of novel or new materials, lower the variability of as-produced properties, and improve the yield.

Given that several different processing sequences can be used to produce a component of a given configuration and that a large number of configurations is sought for various applications, it would be impossible to examine and record data for all possible combinations. Therefore, a new approach is needed in applied research and engineering to express results on the basis of materials phenomena (e.g., thermodynamic or kinetic terms rather than process-specific terms) so that results from one study can be transferred to others. This basis has already been adopted for some aspects of materials processing, such as modeling solidification and deformation.

## Component Manufacture and Repair

Modeling the overall materials manufacturing sequence is a critical need in the development of ULCE. This modeling would need to extend efforts on materials processing to include the reliability of multiple-step processes as well as other aspects such as inspectability. These manufacturing processes must address both initial component manufacturing and in-service repair, since field military equipment will be subject to environmental damage, battle damage, and maintenance damage, as well as normal wear and tear. It is imperative that appropriate repair techniques be developed that can restore most of the original structural capability. Where damage is extensive and/or severe, these repair processes may be more appropriately described as remanufacturing processes. In combat, these repairs must be carried out under significantly less than ideal conditions.

## Enabling Technologies

Central to the critical issue of ULCE-driven development is the fact that uncertainty in knowledge of materials behavior is becoming more costly as demands for greater system performance increase. To respond to these needs and concerns in an ULCE framework, the following enabling technologies are essential. In developing these technologies, materials efforts must be integrated with design and manufacture.

### Techniques for Damage Characterization

Three aspects need to be emphasized--sensors, modeling, and correspondence between field exposures and controlled test conditions. Sensor capabilities have improved dramatically in the past decade in terms of durability of the sensor, reduced size, and sensitivity to various phenomena. However, sensor development has been oriented toward commercial markets such as automobiles, medical devices, and buildings and their usefulness in military structural components needs to be evaluated. In addition, the development of advanced sensors to detect microstructural changes in materials via NDE (e.g., fiber-optic sensors embedded in fiber-reinforced composites) has promise.

Progress in modeling materials behavior has been more successful when behavior is controlled by a single phenomenon or defect, whereas models of behavior dependent on cooperative phenomena have not been able to predict material property values and sometimes not even trends in properties. The major obstacle is the lack of physical understanding of the interdependence of the phenomena involved and continued attention needs to be devoted to this difficult problem. The availability of large computers will be helpful to facilitate sensitivity analyses of the relative influence of different variables on others. Without valid models, much of the output from sensors will not be utilized effectively.

Establishing correspondence between field action (e.g., maintenance or battle damage) and controlled tests is a prerequisite to valid prediction of field damage in a form that can be used quantitatively in design. Greater effectiveness is needed in two areas: tests and simulation of components to model performance and application of sensors to the structure or components to monitor performance. This, coupled with simultaneous measures of service conditions would provide a basis for model validation and provide input data for future analyses.

### Technologies for Enhancing Design for Supportability

Advances in repair methodologies, inspectability, and lifetime prediction models are needed to enhance design for supportability. Also needed are the advances described for damage characterization. Lifetime prediction models that are needed for supportability to ensure timeliness of maintenance and replacement are treated more thoroughly under the next critical issue.

Emerging technologies that will improve component inspectability include sensors, NDE, and three-dimensional computer imaging and analysis. Embedded sensors will allow more thorough documentation of actual service conditions encountered. Sensors monitoring material structural integrity will promote more effective NDE of components, while computer imaging and analysis of components during design could identify optimal locations for sensors and indicate the suitability of different regions for interrogation by various NDE probes. The overall goal of these efforts should be the development of guidelines (although qualitative) for design of generic classes of components using state-of-the-art sensors and NDE.

Limitations and capabilities of repair methodologies need to be considered during design since, clearly, more flexibility and control of repair processes will promote supportability. A promising direction toward these goals involves automated materials processing using a closed-loop approach that combines in-process sensors, computerized data bases, and control systems. Inspection during processing is relatively new and is intended to help avoid the high costs of rejecting fully processed material. Although this approach has been proposed mainly for initial processing of materials, the concept is equally valid, albeit more difficult, for repair methods. An automated materials processing facility may be visualized as consisting of four principal



interconnected systems. The first system is the processor itself, such as weld overlay apparatus for repair of metal alloys or a mold and autoclave for repair of polymer matrix composites. The second consists of sensors that can measure or monitor important properties or characteristics of the material during the processing step. The third, of control algorithms that regulate various experimental parameters. The fourth is a computerized data base that provides information that potentially can close the loop between the sensors and the process controls and replace the human component.

## CRITICAL ISSUES 2

Advanced analytical modeling and simulation methods to predict actual component manufacture, operation, and logistics do not exist to the extent required to preclude the need for physical prototypes and mock-ups.

### Needs and Concerns

#### Life-Cycle Cost Model

ULCE must include the ability to predict the economic consequences of change. Decision-makers need to be able to understand how product design change, modification to a process (manufacturing or support), or an extension to an operational mission affects the life cycle of the product. The impact is measured, to a large extent, in cost. Therefore, an economic representation of the life cycle of a product is a cornerstone for all other modeling and decision-making efforts. In addition, there are also educational and training benefits from the development and use of ULCE cost models.

The life-cycle cost model should be available before conceptual design begins--at the time when product requirements are set. The model should be able to evolve through the life cycle along with the product and be refined as the product, manufacturing, and support definitions are developed. An ideal cost model should be robust enough to allow new technologies, methods, and rules; stable enough to allow back-tracking of decisions; and flexible enough to allow details to be added as they become available. The model needs to include all components of life-cycle costs (development, manufacturing, and support) and should conform to the accounting practices used for decision-making.

#### Prediction of Lifetime Performance

In addition to the economic view, designers need to compare their product design to the functional specifications in a way that accounts for variation in materials, manufacturing, operation, and support. The following particular capabilities can improve lifetime component performance:

- Residual life analysis for components and assemblies to test for malfunctions during operation that are not observable during manufacture. These models require an increased gathering of knowledge about use conditions and prior failure mode, with wide dissemination of the new information.
- Simulations of stochastic materials behavior, taking into account local behavior and failure initiation to provide more accurate predictions of material performance in manufacturing,

support, and operation. These models are needed to predict the manufacturing and support costs and to reduce the product development cycle time.

- Models to predict the damage from operation and various threats for each class of structural components. These models are needed so that complete life-cycle stress analysis can be computed. Stochastic methodologies to describe damage threats are also required.
- Integration of statistical process control models with process models to assess process capabilities at design time. These models are needed to provide a basis for ensuring the stability of the manufacturing process implementation, especially for adaptive control applications.

Validation of the applicability of mathematical modeling and simulations to a given component service environment is required. Before liability questions can be trusted to automated methods, a sound methodology is needed for determining and certifying the accuracy and limitation of models and computer simulations.

### **Analysis and Simulation of Manufacturing Processes**

To obtain good manufacturing feedback during design and, in particular, during conceptual design, more capable and comprehensive modeling and analysis of manufacturing processes are required. Software that can simulate a manufacturing process (e.g., forging, forming, casting, machining) not only provides an opportunity for reduction in manufacturing costs associated with tooling and trial-by-error process development but also can provide designers with process choices early in design. In the past 5 years, computer-aided engineering (CAE) tools have come into use for manufacturing applications. The potential for manufacturing CAE is very large but needs further development. Since current methods of CAE were developed for product design and extensions are needed to account for unique manufacturing needs. For example, large material strain induced by deformations in manufacturing require special attention in finite element modeling and solution algorithms and boundary conditions for processes are, at times, more complex than those for modeling a component in operation.

Higher-level simulations of factories and sequences of manufacturing operations offer considerable promise in providing a product designer with trade-offs and impacts of a potential design. Today, these simulations are used to develop manufacturing strategies and capital plans. These activities are not generally part of product design but are pursued after design. In the ULCE environment, simulation of manufacturing operations is needed as part of the initial design effort; however, extension of today's factory simulation capability is required for ULCE.

### **Analysis and Simulation of Support Processes**

Manufacturing CAE and manufacturing simulation have been demonstrated and are in use to some degree. The extension of these techniques to both support and logistics applications also has great promise. Since the use of these techniques is not widespread, the potential of this application area should be identified for CAE and facilities simulation suppliers. For example, designers in an ULCE environment need to assess the impact of their designs on the necessary support facilities since simulations of repair facilities can give a designer inputs and trade-offs that can be factored directly into a new design.

### **Analysis of the Design Process**

The introduction of the ULCE approach into the design process will have significant impact on the role of today's designers. They will be asked to do more than today while still

maintaining design costs and schedules to near-current levels. Careful analysis of the present design process is required to effectively achieve ULCE. Numerous productivity efforts (e.g., IPAD and CAD-CAM) have been initiated to address design efficiency, yet the demands on a designer remain very high. The use of the computer as a design tool can be expected to increase. Thus the roles of designers, senior designers, managers, and technicians need to be reviewed and recommendations on the best design organizational structures in which to implement ULCE need to be made.

### **Enabling Technologies**

The technologies that are available, that can be developed, or that need to be started to address the critical issue of modeling and simulation are described in the following paragraphs.

#### **Life-Cycle Cost Calculator**

An economic analysis of the life cycle of a design can be satisfied using existing technologies and methods. There needs to be a coordinated effort among government agencies and contractors so that algorithms for life-cycle-cost components are standardized and rates and factors for distribution and support costs can be provided in a common framework with common understanding. (Examples are labor rates for repair centers, shipping costs for spare parts, and power-on hours for machinery.) Such an effort would include a methodology for calculating the life-cycle cost for components, subassemblies, assemblies, and products. The resulting algorithms and definitions could be made public so that software vendors could develop commercial-quality software for use by government contractors.

#### **Life-Cycle Performance**

Another important aspect of modeling and simulation as a critical issue is the need to be able to predict the lifetime performance of a design. Lifetime performance includes manufacturability, operability, durability, and repairability. Comprehensive performance prediction is extremely complex and requires the application of numerous sophisticated technologies, some of which are reviewed in this study. One way to ensure the performance of a design that builds on past applications is to use proven features and approaches where possible.

#### **Stochastic Methods**

To ensure the integrity of new structures, there will continue to be a requirement to analyze the design for stress-strain relations in response to external loads. Finite element methods have matured and are in common use but are only available for deterministic analysis. Thus, variations in materials properties, dimensions, and applied forces can only be considered by repeating analysis computations with different parameter values. This approach is expensive and leads to output that is voluminous and difficult to confirm experimentally or to use to estimate the stochastic behavior of the design. However, stochastic finite element methods have been research topics for the past few years, and the technology is ready for development and deployment in a prototype computational system.

Although this finite element analysis capability can provide an analysis of deformation for specific applied forces, the magnitude of the applied forces needs to be available as an input to the finite element model. This is particularly difficult for dynamic systems because they usually operate across multiple energy domains. An example of a promising technology that provides a unified view of system dynamics across all of these energy domains is bond graphs. Currently,

computational software for bond graphs is limited to certain classes of problems because of limitations in numerical mathematics and automation of bond graph-to-equation algorithms.

### **Product-Process Modelers**

A cornerstone of a computerized design capability is the ability to develop complete product definition descriptions and utilize these descriptions throughout the product life cycle. This capability needs to support the evolutionary buildup of a design from early (conceptual) design stages through manufacture and support. Today's CAD-CAM systems do not fully meet this requirement. Deficiencies lie in the inability to represent all the product definition data since CAD-CAM systems, including second-generation solid modelers and workstation CAD-CAM systems, focus primarily on the geometric data and are deficient in handling nonshape data (i.e., notes, tolerances, specifications).

A key aspect of the modeler is its ability to relate process information to design definition. A desired system would be a combination product and process modeler that contains information on producibility tightly related to design attributes. In this way, designers can see the manufacturing impacts and constraints of their design options. The process data would be provided from manufacturing experience. For example, turbine disk standard hole sizes and finishing processes would be available to the designer in order to specify the type of hole in the new design. With this technique, the best designs and manufacturing efficiency can be enhanced and maintained.

### **Feature-Based Modeling**

A component of the product-process modeler is feature-based modeling, which enables designers to use proved ideas to ensure the manufacturability and performance of the item or assembly. Feature-based modeling also has inherent advantages over conventional dimension-based design:

- The manufacturability of the design is assured, and the development of a process plan can be automated.
- The specification of the design is less ambiguous and more complete than with dimension-based design. The designer is prompted only for the required parameters for the feature and for no spurious or conflicting information, as often happens with conventional dimension-based design processes.

Feature-based modeling is an emerging technology. Some feature-based systems are built on three-dimensional solid modeling systems, and others are based on object-oriented systems. Current research on feature-based modeling has focused on manufacturability in the definition of features and parallel effort to develop durable, reliable, repairable features should be initiated. A preliminary study is necessary to develop at least a first list of "good" features from a support perspective, while refinement of the list could proceed in parallel with research to utilize the support-oriented features during design.

## **CRITICAL ISSUES 3**

The information system for an integrated team approach to ULCE is inadequate.

## Needs and Concerns

The needs and concerns resulting in this critical issue fall into several categories. The first is concerned with the ULCE system structure and functions; the second is related to more specific software requirements for information system components. A third category is concerned with organizational aspects. A fourth is the limited power and memory of mainframes to be used in the solid modeling process of design. Supercomputer systems need to be adapted to support solid modeling as utilized in the design process to support the definition of data for manufacturing. A primary concern is that the needs of the ULCE information system cannot be met adequately merely by writing more software. Indeed, more software packages may be counterproductive if the desired system-level reference models and architecture are not present.

Generic needs and concerns common to all software systems and information systems are not discussed here. Only ULCE-specific matters are addressed. The others may be important but undoubtedly will be addressed as technology moves forward on a broad front.

### Information Reference Model

The primary need and concern for ULCE information systems hinge on the agreement of all involved parties on how the ULCE system might, or should, work. At the system level, there is need for an information reference model of what a working ULCE system might look like. The model would provide a description of the functions and information needed in a prototype ULCE system and would help establish a common basis for learning and commenting on ULCE. The model would illustrate how individual functioning components of present systems could be changed and would show the interrelationships between the components. This effort is needed to carefully comb out and describe the procedures carried out, the considerations governing these procedures, the strategies, the precautions, and the checks. The concern is that, in the absence of definitive models of ULCE information requirements, perceived deficiencies of the system would be met with costly attempts to provide misguided patchwork solutions, which, although powerful in some local sense, would merely further confuse the issue and impede real system-wide progress.

Although an English-language description of the ULCE system might be very valuable as a first step, it would be of somewhat limited utility. There is a need to "tell it to the computer"—that is, to formulate a description or, essentially, a simulation of the system in software. One can then exercise the dynamics of the model to explore the consequences of this understanding. Because business and technical requirements change, the reference model and the ULCE software systems need to be easy to change, tailor, and evolve to fit particular circumstances.

### Intuitively Understandable Software Systems

Because of the complexity and scope of the software systems that describe ULCE systems and support ULCE systems tasks, it is essential that the conceptual structure of such systems mimic as closely as possible and to the extent useful, the thought processes and work habits of the humans who use the system. In other words, such software systems should be "intuitively" understandable to their human users insofar as interface interactions are concerned and insofar as thought processes and expectations are concerned. This lack of "intuitively" understandable software has hampered full exploitation of today's software and will be critical to ULCE system success.

To the extent that such understanding or "user-friendliness" can be implemented, there is hope that information management for task support in ULCE can be implemented in an effective way. The system would be able to edit and update information bases in a meaningful manner, grant access to information in appropriate ways, and remind users of related information and checklists at the proper junctures.

### **Design Assessment Tools**

Design assessment tools need to be available from conceptual design through field upgrades. Designers need to be able to determine whether the manufactured system will function in service and if so whether it will perform reliably.

Software needs include design assessment tools incorporating powerful finite element packages for structural, thermal, and aerodynamic analyses; simulation tools; and capabilities to model and display components to aid in visualizing designs. Similarly, there needs to be software that will allow manufacturing process information and software to be meshed more efficiently and flexibly with information and software from design, manufacturing facilities, materials, and field experience.

In the design process, aids are needed to track the process, set schedules and procedures, provide design information, verify manufacturing assumptions, and provide general information on preferred design strategies. An additional design need relates to materials technology—to track experiences with materials and associated fabrication technologies. Design of materials, treating procedures, and data discrimination will be included in this mode. Maintenance simulation models have the potential capability of simulating many maintenance actions. These simulations would eliminate the need for many physical prototypes.

### **Training and Education**

Fundamental to ULCE is the development of a teamwork culture and methods of management that closely integrate design, manufacturing, and support. Software development alone cannot provide the ideal ULCE environment if data and decisions are not transmittable across technical and managerial boundaries.

Training and education of the ULCE team in system operational philosophy, strategy, style, and accountabilities is also a concern that should be addressed. In particular, it will be necessary to cross-train at least key members of the ULCE team to learn about operating and maintenance conditions. To be effective, the ULCE data base and design rules will contain information relating to reliability, supportability, and producibility; without proper training, these would be of limited use.

Formal education providing perspectives on each of the functions of design, manufacture, product support, materials, and information flow, as well as on the integration of these functions in the ULCE environment, is needed.

### **Organizational Issues**

The development of a powerful, integrated computer environment for ULCE could accomplish much, but its impact will be diminished and could even be negated unless organizations interact in an appropriate manner. While it is difficult to anticipate every situation several examples serve to illustrate the point. Simultaneous access to the evolving design by all departments could lead to chaos unless rules governing design modifications are in place.



However, the simplest rule, sequential reviews after design completion simply recreates the current paper process in electronic form. Likewise if government auditing tools for design review and approval required a paper-based review and approval system, the difficulties or fragmented data bases that it is designed to resolve would reoccur.

## **Enabling Technologies**

### **Cognitive Systems Science and Technology**

The new disciplines of artificial intelligence and neural nets and their specialty subareas based on symbolic processing, nonprocedural programming languages, and use of heuristics need to be motivated to fuse their strengths in order to handle practical problems of significant size and technical difficulty. ULCE is one such endeavor. For example, the science and technology for modeling large complex systems and for implementing a computer simulation of that modeled system need to be developed for ULCE. Such a model and simulation would be quite different from those that would be obtained from existing systems. The model needs to be modularly represented and intuitively understandable, be capable of representing and accommodating many diverse types of knowledge sources, be capable of representing the dynamics and temporal evolution of such systems, and have effective interfaces.

### **Machine Learning Technology**

The performance of computer software systems will not totally meet human expectations unless there is knowledge in these systems of what humans would naturally expect in the way of reasonably intelligent competent behavior under various circumstances. So-called conceptual dependency theory and related investigations have made some progress toward implementing understanding in systems and building memories in systems in such a manner that appropriate associated events can be recalled on cue (Sowa, 1984). Development of such technologies is needed for implementing "understanding" and "learning" capabilities in systems.

Machine learning technology, of which there are several varieties, offers promise. In deductive learning, the intelligent system carries out deductive inferences to establish explicitly facts or rules that are implied by existing data. This capability is important because, in almost all cases, a fact or a rule needs to be made explicit before it can be utilized fully. Deductive learning is the best-understood and best-developed of all the machine learning technologies. Inductive learning is not only difficult but also risky, because the next example may prove previous inductively inferred knowledge to be wrong. However, machine learning can also be achieved with use of connectionist nets or neural nets. This technology has its limitations in that all input needs to be represented in terms of numeric values. For example, a neural net can observe what actions should be taken for a number of specific circumstances and can then generalize on that information to specify the actions that would be appropriate for circumstances that had not been considered before. If it is wrong and is informed of that fact, it would correct its own knowledge to yield improved responses in the future.

### **Data-Base Technology**

Present-day data-base technology is robust but still is not flexible enough. Technology needs to be developed so that data bases can deal with a wider variety of data formats and data types (e.g., text, voice, cursive, video, numeric, graphic, and telemetry). In addition, given "understanding" and "learning" capabilities, data-base management systems could store and retrieve information in ways that allow all expected associated actions to be taken and permit

communications to take place between different data bases supported by different systems. Semantic data-base research seems to be progressing, but not rapidly enough.

### **Product Definition Standards Technology**

The current industry standard for product definition data exchange is the Initial Graphics Exchange Specifications (IGES) developed by a volunteer industry committee supported by the National Institute of Standards and Technology. IGES acts as a common format for product definition, transferring geometric images from one computer system to another.

Although product definition standards have been evolving with IGES and Part Description Exchange Specification (PDES), technology needs to be developed to describe products in feature-based formats, using three-dimensional structures. These efforts will extend the current IGES and PDES formats to incorporate actual manufacturability and supportability features, forms, tolerances, surface quality, and assemblage. Developments in the extraction and representation of manufacturing features can have a significant impact on product development and manufacture.

### **Communication Network Technology**

The ULCE systems considered in this study are distributed systems, and effective communications are essential for their support. The Manufacturing Automation Protocol (MAP) developed by General Motors and the Technical and Office Protocols (TOP) developed by Boeing are promising communication efforts that should be followed and encouraged. MAP, designed for the factory, and TOP, designed for the office and design environments, are being developed to be mutually supportive. These protocols help establish the computing framework by which all the ULCE needs are addressed. Specializations of ULCE might be necessary and should be considered. In particular, extensions to MAP and TOP, which support logistic and field applications, may be necessary.

## **CRITICAL ISSUES 4**

The ULCE team will need to make key decisions while still operating with incomplete information.

### **Needs and Concerns**

#### **Limitations of Field Data**

The collection and reduction of data from the field produce only a limited sample of possible failures. However, the most important but least reliable source of information about actual reliability and supportability is obtained from field feedback. Field operations result in failures under unpredicted stress conditions; failures may also be maintenance-induced. Unlike the laboratory, field data collection systems sometimes fail to document the association(s) between failures and their cause or to "flag" maintenance difficulties. Therefore, they are not adequate to relate a particular problem to a specific design attribute, except in the most obvious cases. Nor do problems encountered in a small sample during a small portion of the expected life of a system necessarily accurately reflect what could be encountered with a larger sample or a longer sampling period. Both shortcomings preclude the development of design rules that would prevent such



problems. Yet translation of performance, costs, and schedule requirements into design rules and design features is critical to attaining the maximum advantage from the ULCE environment.

Application of computer techniques to the screening of data normally collected in the field in standard government format could reveal correlated patterns that, in turn, could be used to identify the cause of failure. These techniques must include safeguards to prevent incorrect conclusions (e.g., they should permit human interrogation and search subroutines).

It is essential that field failure data be added to data collected during laboratory tests (e.g., design qualification tests and prototype tests) to assess the difference between actual field experience and the tests with which the product was accepted for delivery. The comparison will serve two purposes: adjust both the field and laboratory data acquisition process and pertinent specifications for future programs; and develop design rules as well as laboratory test conditions that address the conditions experienced in the field.

It is important to associate the failure data with the specific serial number of the item being maintained, as well as to the next higher assembly and to the system itself (e.g., tail number). Such data would screen for trends that may be related to the next higher assembly or to the weapon system itself. The data collection system containing this information must also be capable of random access, so that comparison of the problems experienced with a specific item to those projected for that item can be made.

### Reference Supportability Data

Dedicated products (e.g., maintenance aircraft) are clearly desirable and often essential for evaluation and verification of supportability. These supportability attributes under controlled conditions require dedicated products ranging from subassemblies to entire aircraft. This approach can be extremely costly because these dedicated products are usually not serviceable after a maintainability and supportability demonstration. However, development contracts do not always allow for such dedicated hardware. Therefore, the dedicated products are quite often mock-ups or a preproduction prototype that has undergone some other testing. Reduction of design data and credible supportability analyses may serve as a substitute for a large portion of this testing. It appears necessary to seek more cost-effective approaches to dedicated maintenance products—e.g., testing components rather than assemblies or coupling performance testing with simulation.

A costly portion of a maintainability and supportability demonstration is the evaluation of fault isolation capability. If the maintenance procedures require human intervention or interpretation of observations, as opposed to automated instructions, the demonstration is usually repeated with other technicians to obtain an average for performing the task. Designs should be sought that include appropriate features that would eliminate uncertainty and risk due to human interpretation. This type of design not only would be better from a supportability standpoint but also would reduce the cost of demonstrations, as well as reduce the risk of discovering problems during the demonstration, thereby preventing costly redesign.

### Uniform Supportability Quantifiers

A set of ULCE parameters for specific classes of applications needs to be established to track life-cycle impacts. The introduction of the term "supportability" in recent years has provided considerable confusion in the "ilities" communities. The term itself is made up of design attributes such as reliability, maintainability, and testability. Each of these measures of merit has

many well-defined quantifiers that are used by the different Services. It is essential that uniform quantifiers be agreed on or developed to simplify interpretation and application of data collected by the different Services to the preparation of design aids.

### Missing and Uncertain Information

There will always be variations in cause-and-effect relationships. Some of these relationships may be between material characterizations and failure modes and frequencies, but others may be between design and failure information. It is not adequate to treat such variations uniformly with statistical methods because variations may be drastically different and have different implications for material selection and design. Advanced methods for processing uncertain and unreliable information will be needed (extended Bayesian statistics, fuzzy set theory, pattern recognition, machine learning, artificial neural nets). Information may appear to be uncertain or unreliable for a number of reasons, including the presence of nonessential related "noise," incomplete specification of process, or erroneous procedures for combining or generalizing interpretations.

In ULCE, a considerable amount of information will have much variation in it. This is especially so for the behavior of materials. There is a need to disentangle the extent to which such variations are caused by unreliable data collection or reporting procedures, variations in material characteristics and/or design and manufacturing factors. There is also a need for procedures for generalizing from such uncertain information to provide estimates of the projected behavior of new materials. A risk model is needed that permits assessment of the risk/benefit of applying a new, poorly characterized material rather than an old, well-characterized material. Also, a managerial tool integrating the life-cycle cost calculator (discussed under Critical Issue 2) with performance and operating criteria is required; this tool would be used to assess the risk/benefit that will be experienced in applying such material with shorter development and test cycles. That assessment should then be used to support investments in developing further analysis tools to study and project the behavior of new material. To develop a practical risk analysis, the relationship of cost drivers to the uncertainties of applying new materials must be understood and quantified in a manner that would permit rigorous mathematical analysis. A risk assessment capability is driven particularly by

- Application of new materials that incur long development cycles that include testing the materials' behavior during manufacturing processes and in the intended use environment, and
- Field data collection, as well as laboratory data, that only provide information on existing material and/or structures from which conclusions are drawn as to the material's failure mechanisms.

This latter approach has been found highly inaccurate in electronics for projecting failures of new components, since the underlying mechanism of their failure is not well understood. Failure mechanisms in structural materials, particularly the new ceramics and composite materials, are also poorly understood. Prediction of failure mechanisms is essential to developing designs that will survive application and maintenance as well as to designing built-in tests capable of projecting failures.

## Enabling Technologies

### Use of Diagnostic Tools

The use of sensor technology would solve a considerable amount of fault-detection and fault-isolation problems. This technology requires further development to make it applicable to weapon systems. For example, work at the Air Force Wright Research and Development Center's Material Laboratory in the area of inspection will potentially result in analytical tools that could evaluate a design to ascertain whether or not it can be inspected with techniques such as x-ray and eddy current measurements. This would prevent the need for demonstrating these design attributes with costly mock-ups.

There are a number of NDE techniques that offer the possibility of being utilized via embedded sensors to continuously monitor vital materials characteristics. These techniques include: fiber optic sensors utilizing fluorescent spectroscopy or polarization spectroscopy; dielectric or electrical conductivity measurement utilizing microwaves, capacitance probes, embedded electrodes or eddy current coils, and acoustic transducers with conventional electrical connectors or with an optical fiber array coupled to acoustic emission sensors. These techniques might be coupled to such conventional techniques as optical holography.

### Rapid Prototyping Techniques

The relation of maintenance problems experienced to the design attributes that could have potentially caused these problems is normally studied under laboratory conditions. Laboratory conditions do not, however, provide an appropriate cross section of field technician understanding and capability and therefore fall short of the objective to facilitate maintenance as envisioned in the Air Force project Forecast II. Thus, there is increasing attention being devoted to techniques that combine hardware and software to automatically generate prototype parts from computer models of the part. At least three such techniques are under development and may have the potential to be useful in prototyping a broad spectrum of parts. In one, Nova Automation Corporation uses a laser to fuse layer upon layer of a powder into a preprogrammed shape. 3-D Systems, Inc., uses a laser to photochemically cure liquid plastic in a process known as stereolithography. Again, numerous passes of the laser build layer upon layer until a complete part has been solidified. A third process, being developed by Hydronetics Inc., uses the laser pass technique to cut layers from metal stock, usually with a copper coating. The coating is used to bond each layer of the stock through a melting procedure.

A "human factors" feature of rapid prototyping techniques currently used for the development of software can be applied to ascertaining the proper execution of maintenance instructions. This feature would capture and relate the technicians' reactions to each and every maintenance instruction provided by their computers. Subsequent analyses could separate their lack of comprehension from design or instruction problems. At present, such separation would have to be performed manually, but artificial intelligence techniques could be designed to mimic at least the major portions of such screening. The rapid growth of the artificial intelligence field, as well as that of training aids, holds promise that automatic characterization of maintenance actions can be accomplished.

### Techniques for Ranking and Selecting Critical Parameters

Techniques need to be developed to assist in ranking and selecting the critical parameters to assist the design engineer in addressing the essential issues in damage-tolerant design features. Artificial intelligence techniques can be used to assist in screening the many cause-and-effect

relationships of damage to material and aircraft structure from a design features standpoint, as well as the impact of such damage to reliability and supportability. This screening would assist the design engineer in addressing the most important parameters first. To support such artificial intelligence techniques, a data base will also need to be developed from actual field experience with aircraft damage, which in turn would relate such damage to reliability impact and aircraft availability.

### **Knowledge-Based and Expert Systems**

Expert systems and new data bases currently being advanced should be developed in such a fashion that design knowledge and design rules can be easily sorted by dominant effect on items such as performance, reliability, manufacturability, and influence on cost and schedule.

The construction of this comprehensive data base would require a systematic approach that first investigates the needed knowledge in each step of a design process, how this knowledge is presented to the designer and design checker, and how it is utilized by them. If this data base were to be constructed to permit growth, it could be expanded to include the best design strategies and application of techniques and technologies collected from the best of evolving designs over the next decade. Human factors techniques will have to be applied extensively, so that the resulting design aids will be easy to use and readily accepted by the ULCE team.

### **Systems for Missing and Uncertain Data**

Systems should be developed that can incorporate uncertain and unreliable information (e.g., material variability). To develop such a system, the progress being made in materials science should be coupled with classic stochastic finite element analyses as well as statistical techniques (such as variance analyses and reduction for Monte Carlo predictions) to serve as tools with which to perform the risk/benefit analysis of new materials application. Life-cycle cost modeling must be included in the risk evaluation to account for all characteristics that impact cost.

Classical Bayesian statistics continue to serve as a departure point for dealing with uncertainties. In that approach, probability is a purely objective measure based on frequency of occurrence, and methods for evaluating joint and conditional probabilities are well understood and can be verified experimentally.

The formalism of fuzzy set theory provides a significant departure from, and augmentation of, that practice by providing a framework for working with uncertainties that are not only inevitable but may, in fact, be desirable. This is because logic rules formulated in terms of fuzzy sets are much more inclusive and powerful than rules dealing with narrowly defined entities. Membership functions provide the interface between generalized statements and quantitative measurements. The former are understandable to humans and easy to store and retrieve, whereas the latter can be very specific and can be attained with use of well-specified procedures.

The disentangling of cause and effect may be aided with use of one or more of the autonomous machine-learning procedures under development. The ID3 method advocated by Quinlan (1983) and the rule inference procedures of Michalski (1980), Winston (1975), and Pao and Hu (1985), provide methods for learning from examples. Generalization procedures are important. Otherwise, the rules would be narrowly defined and not of general utility.

The rapidly developing artificial neural-net technology is also very useful in "discovering" underlying relationships between presumed causes and observed effects and can provide a

procedure for learning from a few examples to yield a powerful generalization mechanism. The mechanism is of such a nature that it cannot be described as a rule or even as a body of rules.

All these technologies are in states of active development, and efforts need to be made to determine how they might be utilized for processing of uncertain and possibly unreliable information in ULCE.

### REFERENCES

- Colley, David P. 1988. "Instant Prototypes," *Mechanical Engineering* 110, No. 7, pp. 68–70.
- Manufacturing Automation Protocol—MAP. 1987. NTIS, Springfield, VA. Citations from the Inspec: Information Services for the Physics and Engineering Database. Rept. for 1975.
- Michalski, R. S. 1980. Pattern Recognition as Rule-Guided Inductive Inference, *IEEE Transactions on Pattern Analysis and Machine Intelligence*, Vol 2, No. 4 pp. 349–361.
- Pao, Y. H., and C. H. Hu. 1985. Processing of pattern based information, Part 1: Inductive methods suitable for use in pattern recognition and artificial intelligence. J. T. Tou, ed. *Advances in Information Systems Science*, Vol. 9, Plenum Press, New York.
- Quinlan, J. R. 1983. Learning efficient classification procedures and their application to chess end-games. R. S. Michalski, J. G. Carbonell and T. M. Mitchell, eds. *Machine Learning*, Tioga, Palo Alto, CA.
- Sowa, J. R. 1984. *Conceptual Structures*, Addison-Wesley, Reading, MA.
- Winston, P. H. 1975. Learning structural description from examples. P. H. Winston, Ed. *The Psychology of Computer Vision*, McGraw-Hill, New York.

## 8

# CONCLUSIONS AND RECOMMENDATIONS

From the needs and concerns and the enabling technologies discussed previously, a set of conclusions and recommendations has been formulated and for each recommendation, a specific action item has been proposed. Most recommendations respond to one of the four critical issues presented in [Chapter 7](#). The first three are general in nature; recommendations 4 and 5 derive principally from the first critical issue; 6, 7, and 8 from the second; 9, 10, and 11 from the third; and 12, 13, 14, and 15 from the fourth.

### GENERAL CONCLUSIONS AND RECOMMENDATIONS

#### Conclusion 1: Program Scale

The breadth of the technologies encompassed by unified life cycle engineering (ULCE) and the level of development needed will require that significant resources be expended to generate a functional ULCE environment. These resources will become available from both the private sector, and government activities (both new and redirected). The proportion of total resource expenditures that will be attributable to each potential source will be dictated largely by the rapidity with which ULCE is implemented. The shorter the time, the greater will be the proportion of the total resource allocation to be met with additional government resources. A review of the capabilities required for full ULCE implementation in a major system (e.g., the advanced tactical fighter) suggests that research, development, and engineering (RD&E) for a period of 10 to 15 years will be needed. Thus, for planning purposes, a development program costing \$100 to \$200 million and directly supporting about 50 technical specialists should be envisaged, with impact in the near, intermediate, and long term. The actions proposed in subsequent recommendations show the scope of program needed; these have been summarized with an estimated time phasing in [Figure 8-1](#). Appropriate time phasing is important if all the diverse technologies required for ULCE are to be developed in concert to provide the technical basis for an integrated ULCE system. Given the breadth and depth of the ULCE program, efforts will have to be leveraged by taking full advantage of R&D projects that are not ULCE-funded.



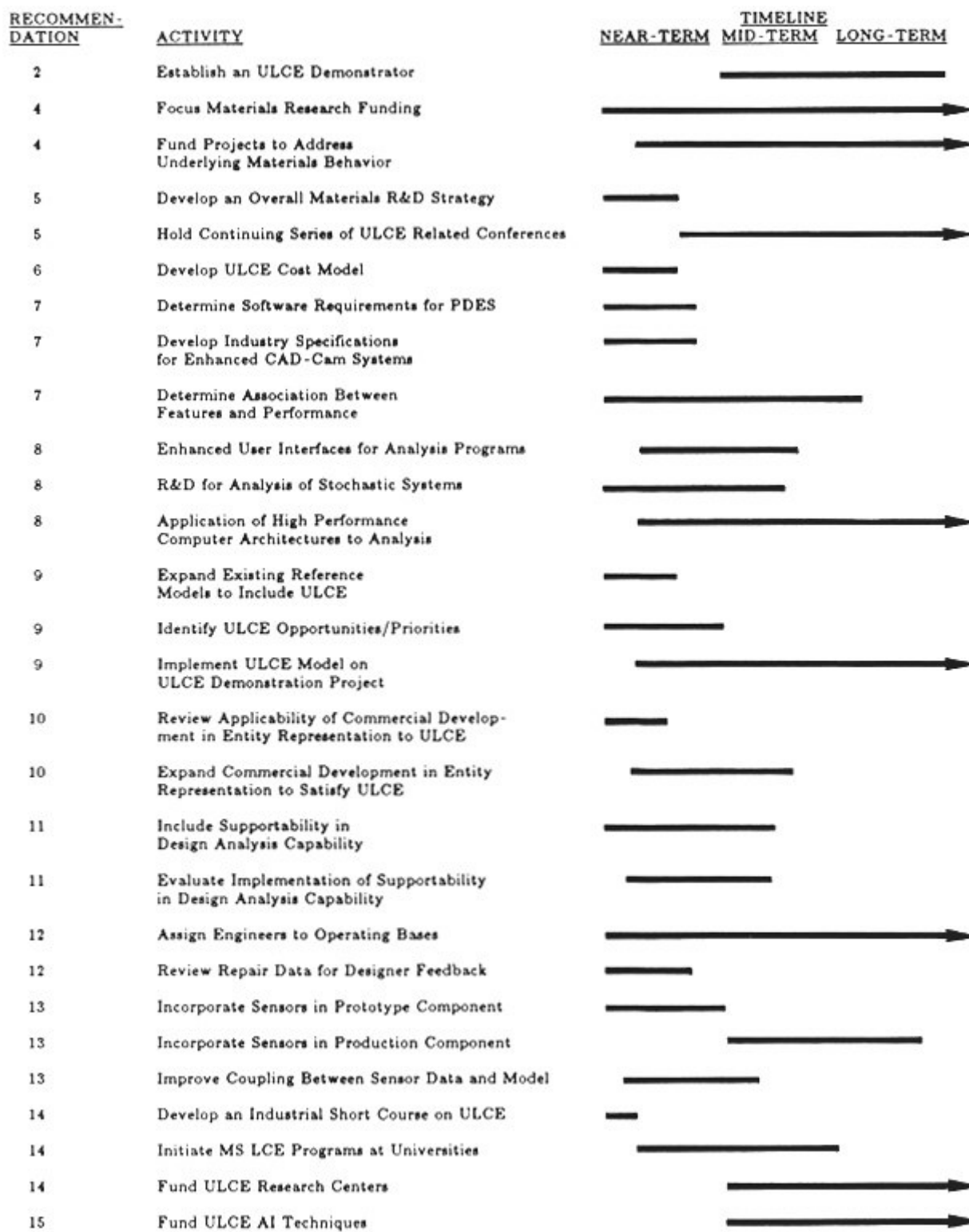

Figure 8-1 Integration strategies for action items.

About this PDF file: This new digital representation of the original work has been recomposed from XML files created from the original paper book, not from the original typesetting files. Page breaks are true to the original; line lengths, word breaks, heading styles, and other typesetting-specific formatting, however, cannot be retained, and some typographic errors may have been accidentally inserted. Please use the print version of this publication as the authoritative version for attribution.

### **Recommendation 1: Define the ULCE program scale.**

#### **Action Item**

- A detailed research and development (RD&E) plan and budget for a 10-to 15-year technology development program must be prepared. The plan and budget should be cognizant of commercial and other government resource allocations. Responsibility for preparation should be assigned to a "program office" and program manager (Recommendation 3 below). However, ULCE R&D can be initiated before a complete plan is approved based on actions proposed in subsequent recommendations in this chapter.

### **Conclusion 2: Demonstration Project**

The breadth of ULCE mandates a series of parallel studies developing the technological underpinnings. Such a series will not, however, provide opportunity for evaluating the effectiveness with which the differing technologies interact or for fostering ongoing technology transfer among contractors, technical personnel, and program managers. Since the major benefit of ULCE is its integrated approach to design, manufacturing, and support, the ULCE development program must include an effort to evaluate the effectiveness with which subsystems are integrated. This effort should be a demonstration project. The process of implementing a demonstration project would provide an opportunity to "look over the designer's shoulder" to better determine whether ULCE has the appropriate tools and prompts to guide the designer to generate the best design. Further, it would in some limited sense provide an opportunity to review the robustness of the design or its ability to accommodate evolutionary changes as the design progresses from concept to final design. In addition, it would provide a mechanism to evaluate how well the ULCE environment accommodates engineering changes.

### **Recommendation 2: Establish a demonstration project for ULCE.**

#### **Action Item**

- A major subsystem or module of a current vehicle should be identified and then redesigned, re-engineered, or remanufactured employing ULCE methods.

### **Conclusion 3: Lead Agency**

ULCE requires the coordination and integration of research, development, and implementation in a variety of diverse technologies. Without overall control of progress and timing, these technologies will not reach fruition simultaneously, so that the systems benefits of ULCE can be achieved. Because the timing is so critical, it is imperative that some agency or individual have overall responsibility for ULCE. The goals of ULCE are relevant to many government agencies, particularly to the Department of Defense (DOD), since it purchases, operates, and maintains equipment designed to its specifications. Because the Air Force has already made a commitment to ULCE and generated momentum, it appears to be the appropriate agency to initiate the ULCE program. Other agencies, including the Army and Navy and non-DOD activities (e.g., National Aeronautics and Space Administration (NASA) and Coast Guard), should be encouraged to define the extent of their involvement.



**Recommendation 3: Assign lead responsibility for developing and implementing ULCE to one agency.**

**Action Item**

- The Air Force should initiate an aggressive ULCE program and provide mechanisms both for collaborating with the Services and other government agencies in their ULCE programs and for reporting on its program to DOD.

**CONCLUSIONS AND RECOMMENDATIONS FROM FIRST CRITICAL ISSUE**

Recommendations 4 and 5 derive principally from the first critical issue, ULCE-driven development of materials design processing and repair methodologies requires integration of research and development across disciplines.

**Conclusion 4: Materials Research**

Materials research and development is usually focused on the characteristics of specific composites, ceramics, etc. Usually the results for one material cannot be used to predict quantitatively results in another material, even in the same class (metals, ceramics, polymers, etc.). Therefore, materials R&D has generated a vast yet incomplete data base. For ULCE, materials behavior must be sufficiently understood to permit reliable extrapolation from a limited set of knowledge. Ideally this extrapolation should permit a valid system prediction for the service conditions anticipated and for the manufacturing procedure used. This capability exists for structural applications of conventional alloys in a qualitative sense but not in a quantitative sense. For development of advanced materials, it is essential to provide at least a semiquantitative capability as soon as possible. For this, an understanding of basic physical mechanisms is required.

**Recommendation 4: Initiate and focus on materials research and characterization appropriate to the needs of ULCE.**

**Action Item**

- Materials R&D should be focused on developing lifetime prediction capabilities for generic classes of applications and materials phenomena. To achieve this goal, it will be necessary to initiate programs to identify the state variables and general principles underlying the mechanical behavior of solids under a broad range of environmental conditions.

**Conclusion 5: Communication**

The very specific needs of ULCE for materials information will lead to changes in the way in which materials research should be undertaken and funded. It is essential that the research philosophy and needs of ULCE be widely known and endorsed by both the funding agencies and the materials R&D community.

**Recommendation 5: Improve communication of ULCE needs within the materials community and governmental funding agencies.**

**Action Items**

- A consensus should be formulated on a materials R&D strategy, consistent with the needs of ULCE, that would be supported and followed in future ULCE-funded research projects. A means to accomplish this would be through a workshop with representatives from all funding agencies, major materials R&D facilities, and major contractors. The responsible agency for ULCE should initiate the organization of this workshop immediately.
- A continuing series of conferences focusing on ULCE-related materials developments should be arranged, possibly in conjunction with national technical societies or with the Henniker Engineering Conferences.

**CONCLUSIONS AND RECOMMENDATIONS FROM FIRST CRITICAL ISSUE**

Recommendations 6, 7, and 8 derive principally from the second critical issue: Advanced analytical modeling and simulation methods to predict actual component manufacture, operation, and logistics do not exist to the degree required to preclude the need for physical prototypes and mock-ups.

**Conclusion 6: Calculating Life-Cycle Costs**

Both funding agencies and contractors need to follow a consistent procedure to predict and assess life-cycle costs, since life-cycle costs will be the basis for decisions on competing design and system attributes. (Note that this does not involve decision-making itself. The intent here is to develop an appropriate common denominator to which engineering characteristics can be reduced, so that alternative concepts can be quickly compared.) A complete life-cycle cost methodology involves many elements, including agreement on standard terminology and procedures; a means of assessing individual component costs while recognizing system costs; quantification of difficult-to-quantify performance parameters; a system that permits initial estimates to grow naturally into detailed estimates as the design evolves, without redoing all calculations; and detailed estimates that are consistent with initial estimates but are not constrained by those initial estimates. Some of these issues must be factored into the conceptual system design, whereas others can be addressed as costs are developed and integrated into the framework of the conceptual design. The key issue, though, is that all parties develop a consensus on the appropriate approach.

**Recommendation 6: Develop a model life-cycle cost calculator.**

**Action Items**

- A standard dictionary of terminology should be developed; this may involve little more than endorsement of MIL Standard 1388.
- A basic cost structure framework should be delineated that includes and clearly identifies each major ULCE cost category and (a) is flexible enough to permit rapid initial cost

assessments and yet powerful enough for final detailed costing; (b) will permit subcontractor data to be merged with a prime contractor's estimates without recalculation; and (c) is modular and self-consistent so that familiarity with any part of the system permits understanding of the whole system. The development of a method by which design attributes can be evaluated on a self-consistent basis is key to the success of ULCE. Thus it is essential both that this action item be developed rapidly and that consensus be achieved on the framework adopted. Government agencies, contractors, and subcontractors must be directly and intimately involved in this effort.

- A cost methodology for difficult-to-quantify mission parameters needs to be developed for inclusion in the cost calculator. Examples might be loiter time, maximum speed, and payload.

### **Conclusion 7: Improved CAD-CAM Systems**

Current CAD-CAM systems provide excellent geometric part definition and display capabilities. However, a complete product description includes not only the part geometry but also tolerances, materials, process descriptions, etc. Commercial CAD-CAM systems do not have the capability of incorporating descriptive, nonquantitative, and nongeometric data into the part data base. Nor do the data bases include information regarding part manufacture, such as process scheme, tooling, fixturing, and cutter selection. In addition, the incorporation of features into the CAD-CAM system is essential. These will enhance and accelerate the mechanical design process and, more importantly, because features convey a more global sense of the design, will provide a convenient basis for linking design and performance attributes. By designing through features and associating features with specific performance attributes such as tool access, failure mechanisms, and inspectability, characteristics such as manufacturability, reliability, and maintainability can be rapidly assessed. Thus improved designs can be created more quickly. (Note that, even though this field is under active commercial development, progress has been slow. Additional support and sponsorship is required to meet ULCE goals, and new approaches are needed.)

**Recommendation 7: Accelerate the development of CAD-CAM systems that incorporate complete product descriptions material performance data and manufacturing process information as well as features-based modeling for use with product and process modelers that support producibility, reliability, serviceability, etc.**

### **Action Items**

- The development of industry standards (e.g., PDES) that could be incorporated in software should be fostered. This would significantly leverage individual industry efforts.
- R&D should be supported on features-based CAD-CAM systems where the features include all aspects of ULCE.
- R&D should be sponsored to define the association between product performance—particularly for manufacturability, reliability, and serviceability—and specific design features.

### Conclusion 8: Analytical Methods

At present, the capabilities of complex systems can be determined with certainty only after they have been operated throughout the desired performance envelope. Inevitably, deficiencies and potential improvements will be identified leading to redesign, component modifications, and further evaluation. Typically this process has been undertaken by reducing the designs to hardware, assembling prototype vehicles, and conducting flight testing. A far superior approach, which is becoming feasible with current computer capabilities, is to construct models whose response accurately simulates that of the structure. With this capability the design can be optimized while it is still in the conceptual stage, thereby eliminating the costs (in both time and money) of modifying and repackaging the physical components. For ULCE, more emphasis needs to be placed on improving both the quality and application of analytical methods—new approaches to dealing with stochastic systems so that the influences of, for example, material variation, tolerance stack-up, operating variability, on the design can be explicitly evaluated. Better coupling of analysis with experimentation is needed, particularly at the component and subassembly levels. The recommended ULCE demonstration project would allow validation of some of these analytical approaches for predicting product behavior.

### Recommendation 8: Expand the application of analytical methods.

#### Action Items

- Development of enhanced user interfaces for analysis programs and enhanced integration of analysis data with other CAD-CAM tools should be promoted. These are not just "user-friendly" issues like common function key assignments, but new modeling methods that reduce the time, effort, and skills required to accomplish the analysis. Needs should be defined by a committee of users and commercial vendors to develop a requirements and standards document. Market forces will lead to commercial development.
- R&D methods warrant support for analysis of stochastic systems that can properly account for variability in materials properties, manufacturing processes, operating environment, etc. The goal of these efforts should be the development of algorithms that can be used in commercial software packages.
- Application of new, high-performance computer architectures to finite element and stochastic modeling systems should be studied. This research should address compilers, application source codes, and basic algorithms and should lead to orders-of-magnitude improvement in processing time. ULCE software applications should be usable for various hardware and operating-system platforms.
- Provide governmental encouragement to computer mainframe producers to develop supercomputer systems that can support the computational speed, memory, and storage required for CAD-CAM solid modeling and automated manufacture.

### CONCLUSIONS AND RECOMMENDATIONS FROM FIRST CRITICAL ISSUE

Recommendations 9, 10, and 11 derive principally from the third critical issue: The information system for an integrated team approach to ULCE is inadequate.

### **Conclusion 9: Information Reference Model**

A major element of ULCE is the capability of providing the designer a wide range of information, engineering data, design data, and engineering analysis capabilities. Since it is impossible to have all the information potentially required by a designer resident in a single computer system, multiple data bases will exist, and access, data distribution, and other issues should be resolved to ensure the appropriate data system structure. Information structure models for computer-integrated manufacturing (CIM), similar to those for ULCE, are currently under development, and there are significant advantages to working for compatibility between the CIM and ULCE reference models. The reference model should be independent of computer supplier, computer hardware, and software.

#### **Recommendation 9: Build and implement a conceptual, system-level information reference model.**

#### **Actions Items**

- Existing conceptual information reference models should be expanded to include ULCE by combining or extending existing models (e.g., IDS, PDDI/GMAP, ICAM, CIM-OSA) and extending these models to include logistics, distribution support, and refinement. A major focus should be on information feedback from manufacturing and support to design.
- With the reference models as a basis, areas of ULCE opportunities and priorities should be identified and recommended for further study, prototyping, and demonstration.
- The reference data model should be employed both in the ULCE demonstration project (Recommendation 2) to evaluate its capabilities and in education and training activities (Recommendation 14).

### **Conclusion 10: Standardized Representation**

Because of the distributed nature of the data required to perform the total design function within ULCE, much of the design effort will involve accessing and manipulating distributed data, incorporating the data in the design, and storing this enhanced design for later access. Because of the volume of data transfer, storage, and retrieval required, it is clear that even very small error rates could significantly affect the process. Thus it is important to employ standard representations that may include a degree of redundancy in the information transmitted.

#### **Recommendation 10: Develop and coordinate standard representations for entities in the ULCE system for unambiguous, reliable, and efficient retrieval, manipulation, and transfer of data.**

#### **Action Items**

- Commercial developments in representation of entities should be pursued to determine if they are appropriate to and sufficient for ULCE needs.
- Shortfalls in commercial development in representation of entities should be funded through the ULCE program with input from industry.

### **Conclusion 11: Conceptual Design Assessment**

The design process consists of several stages, beginning with the concept development and followed by numerous steps of concept refinement. Decisions and trade-offs on both component and systems levels are made continually throughout these design phases, but some major strategic decisions are made in conceptual design. Evaluation tools must be in place to permit rational design assessment at all levels. Furthermore, the results of the early analyses must be retained and used as the basis for the increasingly refined evaluation tools employed as the design evolves. Some vehicle characteristics, particularly performance, can already be analyzed in this way, but producibility assessment is only partially implemented, and supportability is not implemented at all.

#### **Recommendation 11: Develop a rapid analysis tool for the conceptual design phase that embodies producibility and supportability.**

#### **Action Items**

- An approach to design analysis capabilities should be developed that includes a features basis for maintainability and supportability and that is endorsed by contractors and DOD. (Because of the wide variety of CAD-CAM systems in use, implementation of this approach would be the responsibility of the contractor.) Standards for electronic exchange of product definitions need to be extended to include features-based designs.
- A specific, although reasonably simple, structural component for each system should be designed and evaluated according to the approach in the above action item to determine the success with which the approach has been defined and implemented. This should be coupled with the demonstration project (Recommendation 2).

### **CONCLUSIONS AND RECOMMENDATIONS FROM FIRST CRITICAL ISSUE**

Recommendations 12 through 15 derive principally from the fourth critical issue: The ULCE team will need to make key decisions while still operating with incomplete information.

#### **Conclusion 12: Gathering and Using Field Data**

Although programs are in place to identify failures and replacement requirements for the current vehicle fleet, this information has little impact on design. There are two reasons for this: first, the data are frequently not communicated to the designer; second, the data are not organized in such a way that a design engineer can generalize the information to develop associations between failures and design characteristics. One approach to addressing this is to restructure the data gathered previously to make it more relevant. Another is to revise the information-gathering procedure itself so that the data, as gathered, have greater relevance. It is clear that an improved information-gathering procedure will eventually negate the need to restructure previously-gathered data. In the short term, however, it is desirable to make use of the previously gathered data if it can be restructured at reasonable cost.

#### **Recommendation 12: Develop and enhance capabilities to relate field observations to design attributes.**



### Action Items

- Design, process, and manufacturing engineers should be assigned to operating bases for relatively short (6-month to 2-year) assignments. Their responsibilities would be to monitor failures to understand underlying defect mechanisms and to provide direct feedback to designers about repair difficulties along with suggestions to improve reliability and serviceability.
- Current data and lesson-learned repositories related to repair and serviceability should be reviewed to determine whether the data, or a subset of the data, can be restructured to provide designer feedback and, if so, whether this can be done rapidly enough and economically enough to pursue.
- Current data derived from peacetime operations should be reviewed to determine relevance to wartime requirements.

### Conclusion 13: Use of Sensors

Service operations expose structures to damage. Although some of the damage can be anticipated based on past history, many of the failure modes, particularly with new materials, will be incompletely known. Thus they cannot be incorporated in any model. The design options in this case are to overdesign significantly in hopes of providing a sufficient margin of safety for almost any eventuality or to design to a much lower margin of safety and continually monitor vehicle integrity using sensors. Clearly, the second approach should offer a better performance trade-off and therefore should be pursued. Furthermore, since the sensor characteristics are known, the modeling parameters can be coordinated with knowledge of sensor placement, sensor sensitivity or other parameters affecting sensor operation. In addition, by using modeling techniques in analyzing the sensor results, a rational assessment of vehicle capabilities, consistent with the original design approach, can be achieved. Note also that in the short term this technology provides the bridge between current understanding of materials behavior and the future state-variable approach of Recommendation 4.

### Recommendation 13: Develop improved sensor-based tools for periodic or continuous monitoring to assess remaining structural integrity of component materials.

### Action Items

- Development of a prototype component incorporating embedded sensors should be funded and evaluated for its performance under laboratory conditions.
- Parallel development and evaluation of production components incorporating sensors should be undertaken for both laboratory and service conditions. This should be incorporated in the ULCE demonstration project (Recommendation 2).
- Damage models should be reviewed to determine whether they can incorporate sensor data directly to provide immediate output on remaining life. If not, more direct coupling between sensor data and models must be obtained.

### **Conclusion 14: Education and Training**

ULCE will require a broader knowledge of product behavior and will require the design engineer to interpret and evaluate a wide range of information in a variety of contexts. Currently there is no formal educational program that embraces these skills, and there is no opportunity to acquire these skills in a structured manner. Therefore, new educational initiatives are required to develop a framework where new, bachelor-level employees are aware of ULCE concepts and methods. The issue must be addressed on two levels, teaching and research, to ensure that ULCE enjoys sufficient prominence to attract and retain the most capable faculty. University-industry interaction will be vital in ensuring that the curriculum, well supported by research, addresses the technical and management needs of ULCE.

### **Recommendation 14: Initiate and promote education and training in ULCE concepts and methods.**

#### **Action Items**

- On a cost-shared basis between government and industry, the components of an industrial short course on ULCE for personnel from all institutions should be developed. The curriculum development may be aided by faculty involved in university activities and by analysis of case studies. It should be equivalent to a single-semester, 3-credit-hour course at the graduate level.
- Initiation of Master of Science in Life Cycle Engineering programs at several universities should be encouraged. The administration and organization of the programs should be patterned after the graduate programs in manufacturing systems engineering recently started at several universities.
- The initial funding for research centers on ULCE at major universities should be provided through federal agencies. These programs should be organized along the lines of National Science Foundation's (NSF) Engineering Research Centers to provide a coherent environment for developing and integrating ULCE technical and management tools.

### **Conclusion 15: Missing Information**

Vehicle performance will always be a major driver in vehicle design. Thus there will always be incentives to employ higher-performance materials, new manufacturing techniques that promise higher-performance components, etc. Although some body of data will be available to support these new approaches, the volume of knowledge required to completely categorize them, in particular long-term behavior, means that the data available will be incomplete. Thus some approach that rationally evaluates these missing attributes is desirable. Also, the development of appropriate reliable methods for dealing with incomplete information will permit selection of new approaches on the basis of even less information and will support even more aggressive implementation of new technology. Note, however, that most of the artificial intelligence approaches to working with incomplete information are at a very early stage of development, and their implementation will require significant basic research.



**Recommendation 15: Develop better techniques to deal with missing or uncertain information.**

**Action Items**

- Expert systems should be developed where appropriate, recognizing their limited domains of applicability.
- The types of technologies appropriate to the generalization and specialization of inferred knowledge should be developed. Three technologies are appropriate: statistically based, machine learning, and neural networks.
- Other artificial intelligence approaches should be pursued on a long-range basis.

## APPENDIX A

### CASE STUDY OF A METALLIC GAS TURBINE DISK

This case study was conducted to compare results of an actual hardware experience with generic ULCE needs and concerns being considered by the committee. The high-pressure turbine disk of the F110 augmented turbofan engine was selected as a technically appropriate and timely example. It should be noted that the F110 engine represents the first application of the U.S. Air Force's Engine Structural Integrity Program (ENSIP) on any General Electric Company parts. This disk was one of these parts. ENSIP was not conceived as ULCE at the time but is similar in some respects.

This case study was based on the experience gained by the various engineers involved with the design of this turbine disk; the division of that task is shown schematically in [Figure A-1](#). The five standard life-cycle cost phases are shown on the horizontal axis, from concept to operation and support. The five dynamic engineering functional activities have been superimposed at the top of the sketch to create a three-dimensional image for representation of the total ULCE requirements. Materials development and characterization, as well as product design, are of necessity focused at the earliest life-cycle phases. To be most effective, the integration of manufacturing, assembly and test, and product support needs must also be addressed at this stage. The later this total view of the life cycle takes place, the less impact it has. A checklist (shown later) for the logical consideration of the details required was developed for each of the activities. As these lists were being constructed, the needs and concerns that were not fully addressed during the design effort for this particular turbine disk were recalled and recorded. Later in this case study they are compared to the critical issues defined by the ULCE committee.

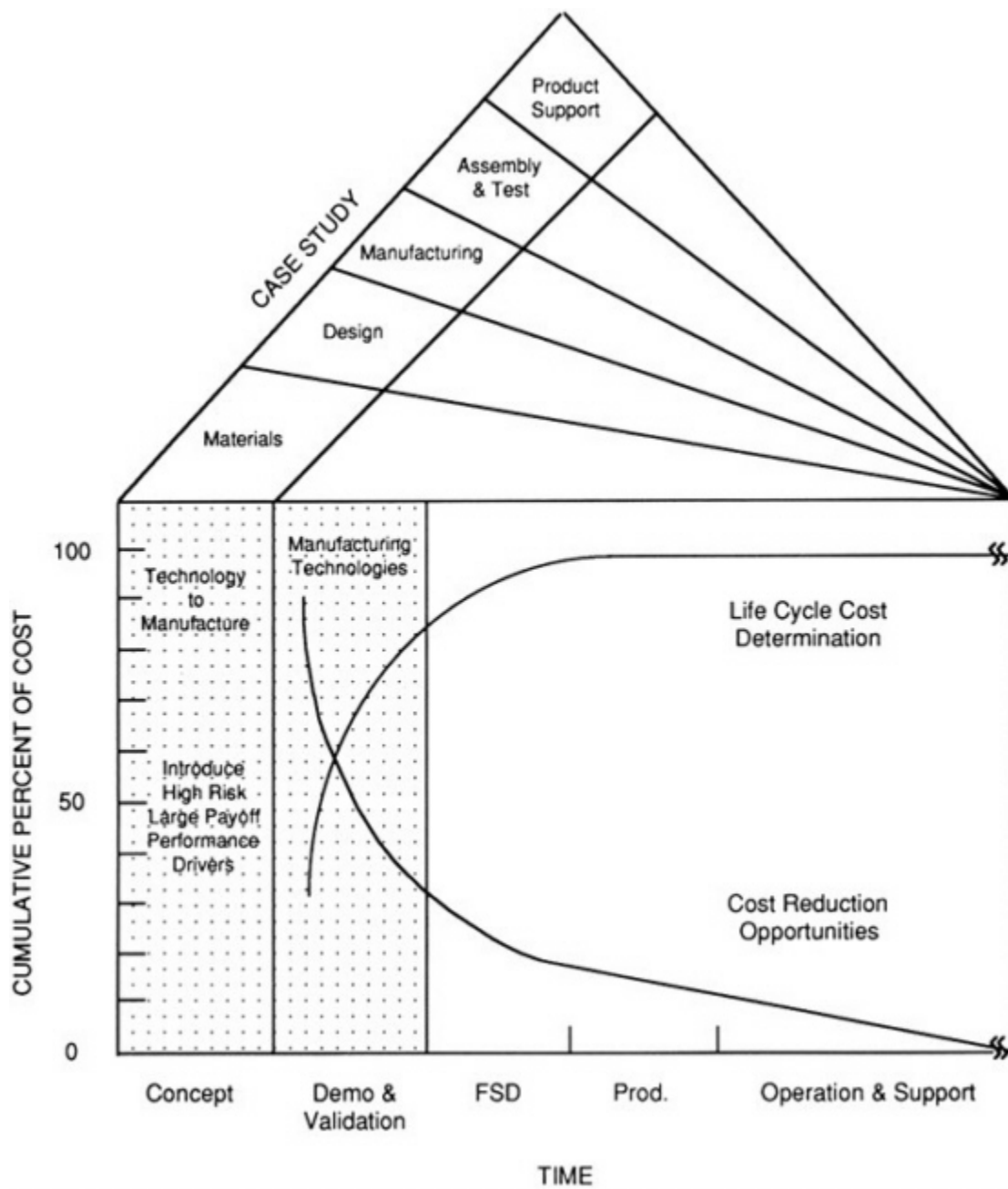

Figure A-1 Conceptual sketch of life-cycle engineering case study.

About this PDF file: This new digital representation of the original work has been recomposed from XML files created from the original paper book, not from the original typesetting files. Page breaks are true to the original; line lengths, word breaks, heading styles, and other typesetting-specific formatting, however, cannot be retained, and some typographic errors may have been accidentally inserted. Please use the print version of this publication as the authoritative version for attribution.

The materials checklist (Figure A-2) recognizes that research and development of new materials almost always occurs ahead of the identification of a specific application. Nearly all performance improvements hinge on the advancements made in the increased capabilities of materials and the adequacy of characterization.

A. DEVELOPMENT PRIOR TO APPLICATION

1. TARGET PROPERTIES
  - a) OPERATING ENVIRONMENT
  - b) DESIGN CRITERIA
  - c) PHYSICAL & MECHANICAL PROPERTIES
  - d) NDE REQUIREMENTS
  - e) MATERIAL BEHAVIOR UNDERSTANDING
  - f) ALGORITHMS FOR ALLOY DESIGN
2. QUALITY PROGRAM IN PARALLEL
  - a) IMPROVEMENTS IN KNOWN MATERIAL LIMITATIONS
    - TOUGHNESS
    - FATIGUE LIFE
    - CORROSION RESISTANCE
  - b) FIELD AND INDUSTRY EXPERIENCE
3. PROCESSING SPECIFICATIONS
  - a) MELTING PRACTICE
  - b) CONVERSION
  - c) METALLURGICAL CHARACTERIZATION
  - d) INSPECTABILITY
4. DETAILED DATA GENERATION
  - a) STATISTICAL PROPERTY LEVELS
    - CRACK INITIATION & PROPAGATION
  - b) MATERIAL BEHAVIOR QUANTIFICATION
5. PRODUCIBILITY
  - a) INPUT MATERIAL AVAILABILITY
  - b) INPUT MATERIAL YIELD
  - c) HEAT TREAT
  - d) COATINGS
  - e) MACHINABILITY
  - f) INSPECTION
  - g) REPAIR
6. COMPUTER SYSTEMS

Figure A-2 Materials checklist.

The design checklist (Figure A-3) meshes the technical weapons systems performance requirements and the manufacturing and operational support concern. Here is where, in a unique, highly advanced weapons system, real innovation and creative risk are necessary if performance requirements are to be met and coupled with ULCE.



- A. PERFORMANCE CRITERIA**
  - 1. EXPECTED OPERATING CONDITIONS
- B. MATERIAL SELECTION**
  - 1. PROPERTY LEVELS
  - 2. PERFECT MATERIALS VERSUS FRACTURE MECHANICS
  - 3. PRODUCIBILITY & COST
  - 4. INSPECTIBILITY
  - 5. FIELD EXPERIENCE
  - 6. MANUFACTURING EXPERIENCE
- C. MECHANICAL & AERODYNAMIC DESIGN**
  - 1. DESIGN PRACTICES MANUAL
    - a) HISTORICAL DATA
    - b) FIELD EXPERIENCE
    - c) COMPONENT DEVELOPMENT INFORMATION
    - d) CHECKLISTS
  - 2. COMPUTER AIDED DESIGN
    - a) INTERACTIVE GRAPHICS
    - b) RELATED DATA BASED-COMPUTER-AIDED ENGINEERING  
COMPLETE STRESS ANALYSIS  
THERMAL MECHANICAL STATIC AND DYNAMIC
    - c) ASSEMBLY & BALANCE
    - d) PRODUCIBILITY & COST
    - e) MAINTAINABILITY
    - f) REPAIRABILITY
    - g) SUPPORTABILITY
  - 3. DESIGN TO COST
    - a) TEAM LEAD BY DESIGN ENGINEERING
    - b) FACTORS CONSIDERED
  - 4. DESIGN REQUIREMENTS LIFE OBJECTIVES
  - 5. COMPONENT TEST
    - a) DESIGN VERIFICATION
    - b) FIELD HISTORY EXPERIENCE
  - 6. ENGINE TEST
    - a) FACTORY QUALIFICATION
    - b) FLIGHT FLEET LEADER PROGRAM
    - c) FIELD EXPERIENCE
    - d) MAINTAINABILITY
    - e) REPAIRABILITY
    - f) SUPPORTABILITY
  - 7. FIELD EXPERIENCE
    - a) MONITORING CRITERIA
    - b) EASE OF MAINTENANCE
    - c) INSPECTION CRITERIA
    - d) REPAIR  
DOVETAILS, BLADE RETAINERS, SEALS, DUCTS., ETC.

FIGURE A-3 Design checklist.



It is fundamental that a disciplined, monitoring, and measured capability of manufacturing be reflecting in the engineering design. The manufacturing checklist (Figure A-4) highlights the all-important requirement for consideration of producibility and cost.

- A. MATERIAL DESIGN INPUT TO DESIGN ENGINEERING**
1. **AVAILABILITY**
    - a) SECOND/ALTERNATE SOURCE
    - b) SUPPLIERS
      - CAPACITY/CAPABILITY
      - QUALITY HISTORY
      - LONG TERM BUSINESS STABILITY
      - MANAGEMENT ATTITUDE FOR PROBLEM SOLVING
      - ACCEPTANCE OF OUR SPECIFICATIONS
  2. **COST**
    - a) SUPPLIERS
      - TECHNICAL STAFF DEDICATED TO COST REDUCTIONS
      - ATTITUDE FOR COST REDUCING & SHARING
      - PHYSICAL CAPABILITY TO REDUCE COST
      - "FLY TO BUY" RATIO
    - b) SHOULD-COST EVALUATION
    - c) DEVELOPMENT FUNDING NEEDS
  3. **PRODUCIBILITY**
    - a) SHOP CAPABILITIES
      - NEW PROCESSES NEEDED
      - MAJOR PROCESS CHANGES NEEDED
      - LACK OF EXPERIENCE/NEW DESIGN CONCEPTS
      - LACK OF EXPERIENCE/NEW MATERIALS
      - NEW HTO PROCESSES NEEDED
    - b) NEW FACILITIES TOOLING REQUIRED
    - c) DEVELOPMENT FUNDING NEEDED
  4. **EXPERIENCE**
    - a) SPC DATA
    - b) MATERIAL CONVERSION HANDBOOK DATA
      - FORMABILITY
      - WELDABILITY
      - MACHINABILITY
- B. PRODUCIBILITY INPUT TO ENGINEERING**
1. **PROCESS CAPABILITY**
    - a) SPC DATA
    - b) STACKUP ANALYSIS
  2. **AVAILABILITY RESOURCES**
    - a) FACILITIES
      - PLANT & EQUIPMENT
    - b) TOOLING
    - c) RESEARCH & DEVELOPMENT
      - NEW PROCESSES
      - PROBLEM PROCESSES
      - MAJOR PROCESS CHANGES
      - NEW DESIGN CONCEPTS
      - NEW MATERIALS
    - d) SUPPLIER STATUS (ESTABLISHED VERSUS NEW)
    - e) PERSONNEL AVAILABILITY
  3. **TIME CYCLES VERSUS LEAD TIMES**
  4. **DATUM SURFACES REQUIRED**
  5. **COST TARGETS**
  6. **REQUIRED DESIGN CHANGES**
  7. **DEVELOPMENT FUNDS NEEDED**

FIGURE A-4 Manufacturing checklist.



Historically, assembly and testing have taken their ordered position following the design and manufacturing steps necessary for the production of a successful weapons system. Figure A-5 lists many important items that should be given up-front attention. Assembly and test operations require unique considerations for the production cycle and adequate provision for product support.

- A. ASSEMBLY**
1. **STACK-UP**
    - a) RMS ANALYSIS VERSUS INVENTORY
    - b) MANUFACTURING DATUMS VERSUS BUILD DATUMS
    - c) DOUBLE DIMENSIONING
    - d) START THRESHOLDS
  2. **HISTORICAL PROBLEMS**
    - a) PSC DATA
    - b) MRS DATA
    - c) TRENDING
    - d) SMALL ISSUES
  3. **MOCK-UP NEEDS**
  4. **CAPACITY LIMITS**
    - a) BUILD STANDS
    - b) TEST CELLS
    - c) BALANCE EQUIPMENT
    - d) GRIND EQUIPMENT
    - e) ETC.
  5. **UNIQUE REQUIREMENTS**
    - a) MACHINE SUBASSEMBLIES
    - b) NON-INTERCHANGEABLE DETAILS
    - c) ELEMENT BALANCING
  6. **COST**
    - a) SUBASSEMBLY CYCLES
    - b) INVENTORIES
    - c) MAJOR ASSEMBLY CYCLES
  7. **DEVELOPMENT EXPERIENCE**
  8. **SYSTEM INTERFACES**
- B. TESTING**
1. **STANDARD TEST PLAN**
    - a) VARIATION UNIQUE REQUIREMENTS IN RUN SCHEDULE
    - b) CYCLE TIMES
    - c) UNIQUE INSTRUMENTATION
    - d) UNIQUE TECHNIQUES
    - e) FORECASTED ACCEPTANCE RATES
    - f) FORECASTED PERFORMANCE MARGINS
    - g) TEAR-DOWN INSPECTION PLAN
    - h) RETEST PLAN
  2. **FACILITIES**
    - a) CELL CAPACITY/CONVERSIONS
    - b) SPECIAL MOUNTING SYSTEMS
    - c) SPECIAL TOOLING
    - d) UNIQUE SLAVE HARDWARE
    - e) SAFETY EQUIPMENT
  3. **DEVELOPMENT PHASE LEARNING**
    - a) COMPONENT INFANT MORTALITY
    - b) ANTICIPATED SPARES USAGE
    - c) OVERHAUL LIMITS (CAUTIONS)
  4. **SPECIFICATIONS FOR PREP-TO-SHIP**
    - a) CONTAINER SPECIFICATIONS
    - b) UNIQUE PROBLEMS

FIGURE A-5 Assembly and testing checklist.



As shown in Figure A-6, product support requires attention in parallel with the other aspects of ULCE, and a comprehensive experience data base can be an invaluable aid to this up-front effort. Once the product reaches operational status, the collection of field experience and the knowledge gained of environmental conditions must be fed back to design engineering to continuously improve operational reliability and future designs.

- A. MATERIAL SELECTION INPUT**
  - 1. EASE OF REPAIR
- B. DESIGN REVIEW WITH FIELD ENGINEERING**
  - 1. LESSONS LEARNED FROM FAILURES
  - 2. MAINTAINABILITY
  - 3. REPAIRABILITY
  - 4. SUPPORT IN THE FIELD
  - 5. RELIABILITY
- C. DEPOT MANUAL FOR MAINTENANCE**
  - 1. TEAR-DOWN & ASSEMBLY PROCEDURES
  - 2. INSPECTION PROCEDURES
  - 3. TEST AFTER OVERHAUL
  - 4. METHOD OF DISTRIBUTION
    - a) LARGE MANUALS
    - b) MICROFILM
  - 5. ISSUED PRICE TO FIELD OPERATION
    - a) EXPERIENCE FROM FACTORY TEST
    - b) REPAIRS DEVELOPED DURING FACTORY TEST
    - c) MODIFICATIONS ON QUARTERLY BASIS BASED UPON FIELD EXPERIENCE
- D. MANUFACTURING QUALITY AUDIT REVIEWS**
  - 1. HELD AT MANUFACTURING SITE
  - 2. DESIGN, QC PRODUCT SUPPORT
    - a) REVIEW MANUFACTURING & PROCESSING
    - b) COMMUNICATE FIELD PROBLEMS RELATED TO MANUFACTURING
  - 3. QUALITY PROBLEMS REPORTED
    - a) QC INVESTIGATES
    - b) RETROFIT IN FIELD
    - c) QUALITY INTERFACES WITH ENGINEERING  
MANUFACTURING, ASSEMBLY & TEST, AND PRODUCT SUPPORT
- E. FIELD ENGINEERING**
  - 1. DESIGN RELATED FIELD PROBLEMS
    - a) AD HOC DESIGN REVIEW WITH ENGINEERING
  - 2. ASSEMBLY & TEST FIELD PROBLEMS
    - a) AD HOC REVIEW
    - b) FIELD USES EXPERIENCE FROM FACTORY TEST TO HELP DEPOTS
    - c) FACTORY USES EXPERIENCE FROM FIELD TEST TO HELP FACTORY TEST
  - 3. DOCUMENTATION OF FIELD HISTORY
    - a) REVIEW HIGH-TIME ENGINES (FLEET LEADER)  
TRIGGERED BY FIELD ENGINEERING--COMPLETE TEAR-DOWN,  
INSPECTION & LAYOUT OF COMPONENTS
    - b) 400 COMPONENT TRACKING LIST  
BY PART NUMBER & SERIAL NUMBER  
COMPUTER RECORD OF HISTORICAL DATA (LESSONS LEARNED)  
AVAILABLE TO FIELD ENGINEERING

This turbine disk case study, undertaken to explore the completeness of the committee-defined ULCE critical issues, identified 18 needs and concerns that in retrospect would have aided the initial design effort. These needs and concerns were expressed by the engineers who had been involved with the design of the turbine disk:

1. Life-cycle engineering flexibility is often limited on critical components, driven by the state of the art to meet performance criteria. However, powder metallurgy development for this particular component was driven by producibility needs.
2. Expert systems to aid development of materials and processes design for specific property needs.
3. Improved understanding of material behavior and defect sensitivity (static and dynamic).
4. Understanding of inspectability of the various materials forms and sufficient knowledge of the process techniques to maximize capability.
5. Better processing to prevent material defects.
6. Surface enhancement techniques to negate effects of handling damage and surface defects.
7. Models to simulate fatigue and damage tolerance interaction to avoid need for physical mock-ups.
8. Models for establishing defect distributions.
9. Improved correlation of dynamic material characteristics with life predictions.
10. Enhanced inspection techniques to improve detection and characterization of defects (new and field parts).
11. Better cutting tools and shaping techniques.
12. Computer models of air flow and heat transfer in rotor cavities.
13. Correlation of fracture mechanics and low cycle fatigue.
14. Process capability data for all material (supplier) and shop manufacturing processes.
15. No proprietary suppliers or second sources.
16. Improved metrology systems for assembly.
17. Computer modeling to reduce performance testing.
18. Formal capture and use of field experience data.

Of the 18 case study items identified, each was associated with at least one of the four critical issues defined by the committee (Figure A-7). This case study, through these comparisons, supports the validity and completeness of the generic critical issues developed by the committee.

<u>GENERAL CRITICAL ISSUES</u>	<u>CASE STUDY ITEMS</u>
1. ULCE-DRIVEN DEVELOPMENT OF MATERIALS, PROCESSING, AND REPAIR METHODOLOGIES REQUIRES INTEGRATION OF R&D ACROSS DISCIPLINES.	1-2-3-4-5-6-10-11-14-15-16
2. ADVANCED ANALYTICAL MODELING AND SIMULATION METHODS TO PREDICT ACTUAL COMPONENT MANUFACTURE, OPERATION, AND LOGISTICS DO NOT EXIST TO THE EXTENT REQUIRED.	7-8-9-12-13-17
3. THE INFORMATION SYSTEM FOR AN INTEGRATED TEAM APPROACH TO ULCE IS INADEQUATE.	14-17-18
4. THE ULCE TEAM WILL NEED TO MAKE KEY DECISIONS WHILE STILL OPERATING WITH INCOMPLETE INFORMATION.	ALL

Figure A-7 Generic critical issues versus case study.

About this PDF file: This new digital representation of the original work has been recomposed from XML files created from the original paper book, not from the original typesetting files. Page breaks are true to the original; line lengths, word breaks, heading styles, and other typesetting-specific formatting, however, cannot be retained, and some typographic errors may have been accidentally inserted. Please use the print version of this publication as the authoritative version for attribution.

About this PDF file: This new digital representation of the original work has been recomposed from XML files created from the original paper book, not from the original typesetting files. Page breaks are true to the original; line lengths, word breaks, heading styles, and other typesetting-specific formatting, however, cannot be retained, and some typographic errors may have been accidentally inserted. Please use the print version of this publication as the authoritative version for attribution.

## APPENDIX B

# CASE STUDY OF A COMPOSITE AIRFRAME STRUCTURE

A composite horizontal stabilizer was chosen as the subject for the composite airframe structure case study. Life-cycle engineering was examined in today's environment from conceptual design through production and into operational feedback phases. The subject stabilizer was a composite-skinned structure with a metal splice plate over honeycomb core.

The same procedure was used for a future idealized environment. The subject stabilizer for the future study was a totally co-cured composite structure without metal splice plates. By comparing the present and future or proposed methodologies for life-cycle engineering, needs for each phase of product development (conceptual design, prototype, full-scale development, production, and operation) were isolated. These needs were then compared to needs identified by the committee and the resulting critical issues in order to verify or refute them. The case study of the composite horizontal stabilizer that follows includes today's environment, an idealized future environment, and the resulting needs.

The contemporary structure studied was an F-15 horizontal stabilizer ([Figure B-1](#)) designed in the 1970s using methodologies and practices consistent with the technologies and tools available. The design process has changed very little since then, and a similar design process would be followed today. The conceptual design was developed by design, material and processes, strength, weights, aerodynamics, and loads engineers with inputs as required from other manufacturing and engineering disciplines.

The stabilizer design was completed and forwarded to individual experts for review of the design concepts as they relate to areas such as producibility, reliability, maintainability, and repairability. Individual input from each of these areas would be forwarded to design engineering for incorporation in the design.

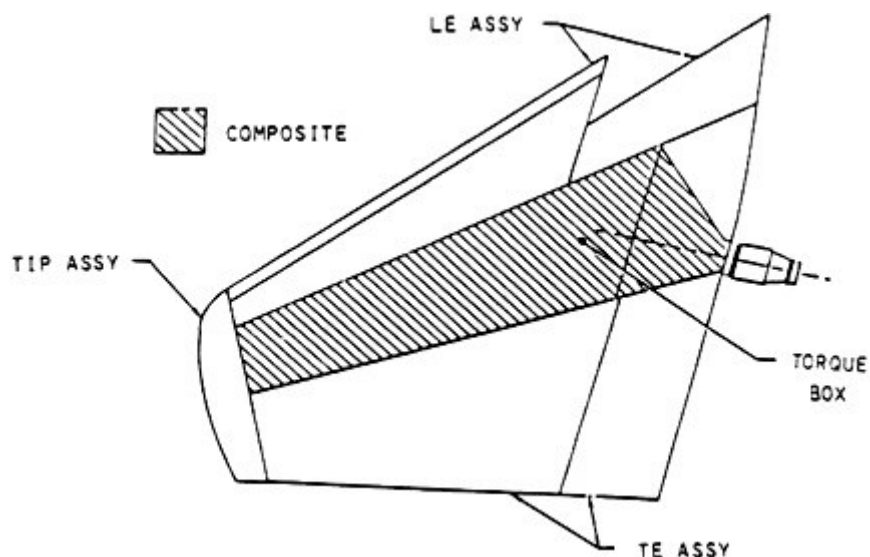

Figure B-1 Plan view of the F-15 horizontal stabilizer.

The materials for the composite horizontal stabilizer were assessed for material properties and history (Figure B-2). Costs shown were budgetary and based on divisional estimates for engineering study purposes.

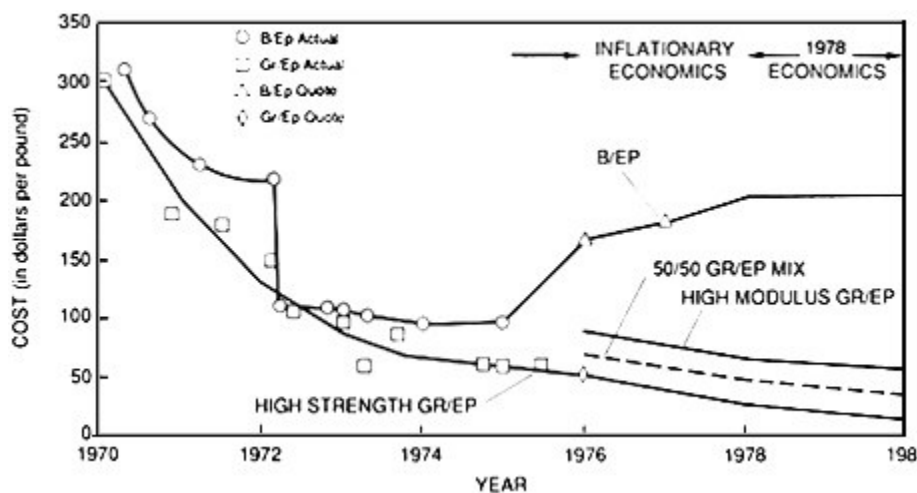

Figure B-2 Material properties and history assessment.

Source: 1970–1975 procurement actuals; 1975–1980 vendor quotations.



The assembly method selected was a bonded honeycomb torque box overlaid with graphite-epoxy laminated skins and a removable, mechanically attached aluminum leading edge and trailing edge section. As noted in sections A and B in Figure B-3, conventional fastening methods were used—i.e., bolts and nut plates.

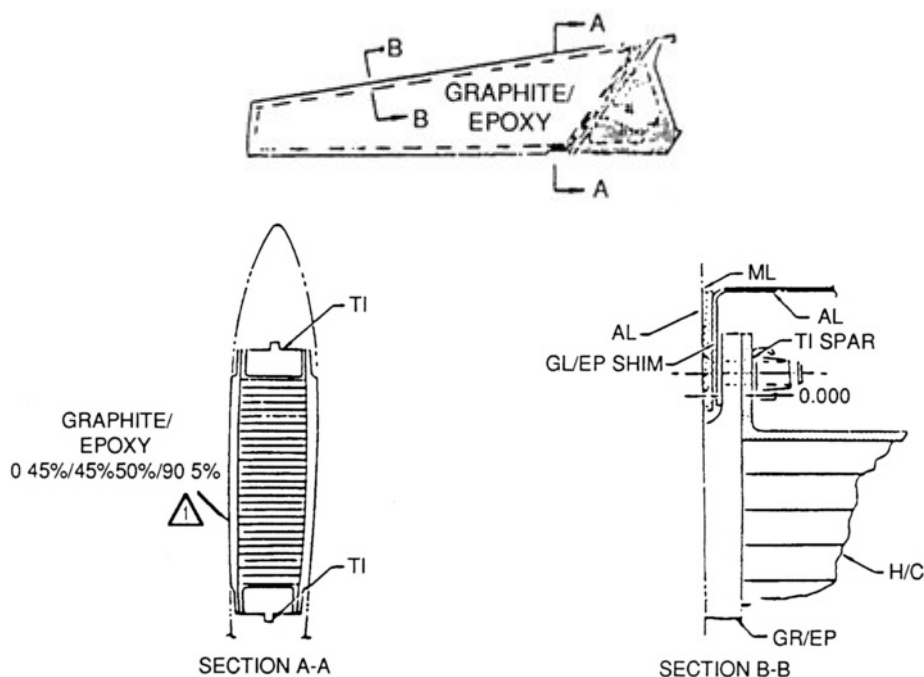

Figure B-3 Torque box assembly method.

Tooling employed was state of the art for the 1970s and was based on experience and past history on aluminum honeycomb assemblies, with consideration for cost and schedule constraints was then factored in.

Prototyping, if done at all, was accomplished as a feasibility validation through the use of a physical development fixture approach. This is a labor-intensive activity that generally yields a low level of fidelity. The physical development fixture is reviewed during various stages of completion by numerous "experts." Paper feedback of problems from engineering, manufacturing, quality assurance, and product support are sent to design engineering for consideration of design changes for a completed design.

During full-scale development, additional problems are found as the integration of structure and systems occurs. This may lead to delays as interface problems are discovered, and assembly and/or tooling procedures may require modification. Inspection changes may also be required, and basic engineering changes to the design are also common at this time. Most of these changes are in the form of "paper feedback" and affect a number of different areas of the plant.

In summary, the contemporary method of life cycle engineering is paper dependent. It is not structured or organized to prevent numerous reoccurrences of the same problems. It lacks



feedback loops for some data altogether; and, over product quality, reliability, and supportability suffer as a result.

The next task of this case study was to probe the future and determine those things that would be necessary in an idealized future environment to best support life cycle engineering, and its attendant improvement in total product quality.

In this idealized future environment, during the development phase of a horizontal stabilizer the conceptual design will be developed digitally by design, material and processes, strength, weights, aerodynamics, and loads engineers with electronic or digital inputs from producibility, reliability, maintainability. Inputs from rules imbedded in the digital system will be available, such as a mature reliability and maintainability in computer-aided design (RAMCAD) system, presently under development. Additionally artificial intelligence (AI) systems will incorporate reliability, maintainability, and supportability such as expert systems for access door design, equipment mounting, crew system safety, scheduling etc.

Also, in the future environment the "ilities" will carry as much weight with customer and contractor as performance. For example, an "ilities" warranty will be required, and "ilities" requirements will be spelled out in the same detail as performance. (An extension of warranties increasingly used in the current environment.)

The best design practices for composite structural members will be imbedded in the digital CAD-CAM-CAL-CAQA system. The system will contain parameters on failure modes, damage tolerance, typical repairs, wear-out characteristics, predicted moisture effects, and tooling concepts. An integrated data base for engineering, manufacturing, quality assurance, and product support will be required. This will allow data to be shared rather than duplicated or lost altogether (Figure B-4).

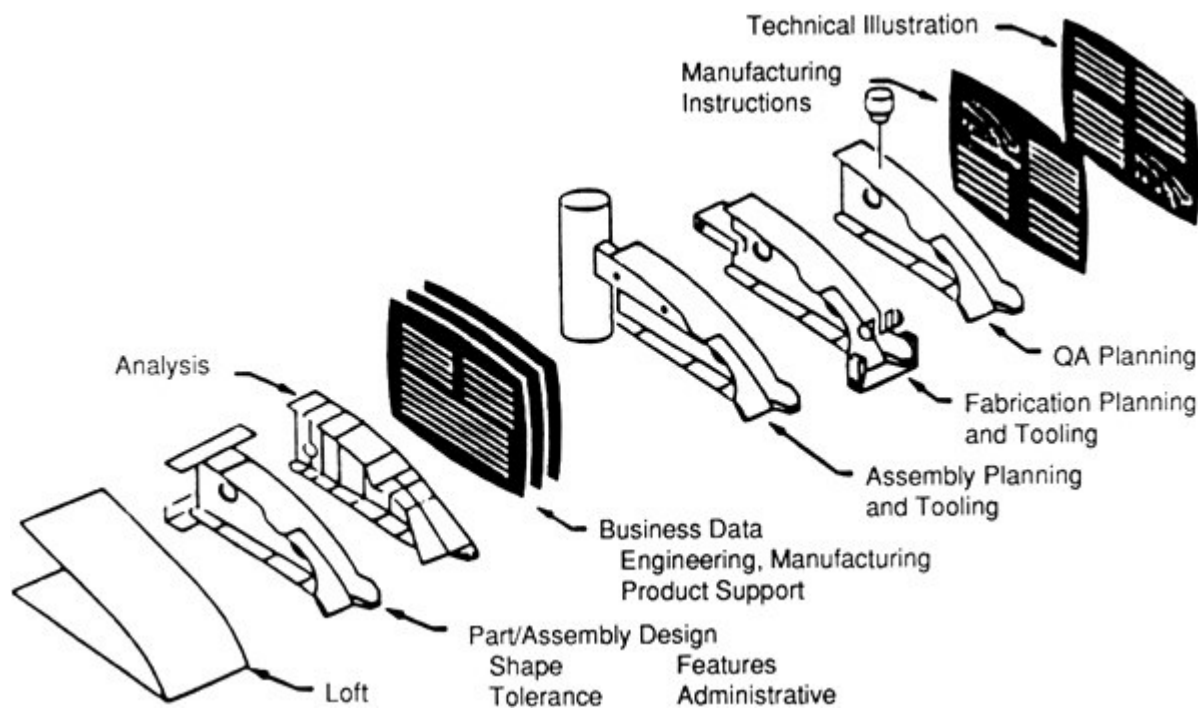

Figure B-4 Shared data base concept.

This shared data base concept will minimize data stored, maintain attachment to data originator for updates (change notification), maintain attachment to data originator to propose changes to better fit downstream users needs (change proposals), and allow status change notification (shared, prerelease, release). It will also provide a means to organize "lessons-learned" data from related current and prior programs.

Prototyping will be done electronically with more analytical assurance of component performance before committing to hardware fabrication. It would establish relationships, assess integration and provide tools for anthropometric and ergonomic analyses.

Electronic integration of systems and structures will include an electronic development fixture (EDF) to minimize changes and find errors before parts are made and assembled. Electronic development fixtures will reduce cost, reduce span time, and provide more accuracy than the previous hardware development fixture method. Electronic development fixtures will allow the aircraft to be divided up into zones, with engineers from many disciplines responsible for all activities within the individual zones. This will provide for better coordination of all systems and structures in a given zone, foster coordination and increase knowledge transfer. The use of a full-scale electronic development fixture will also permit a fine-tuning of the design to take advantage of the efficiencies of volume production in areas like pressings and forgings.

The use of a common electronic data base by the whole design team (Figure B-5) will provide many new approaches for users of the engineering design definition, such as electronic quality assurance of parts prior to fabrication and assembly. Other downstream users of engineering digital definitions will allow for the automated processing of composite parts. For example, the manufacturing planning function will document models of processes, plan automated fabrication and assembly operations, use the computer mock-up EDF instead of a hard metal airframe, and release detail designs in digital data set formats. This will lead to earlier isolation of problem areas for correction in detail and assembly processes, prior to full scale production via the common electronic data base.

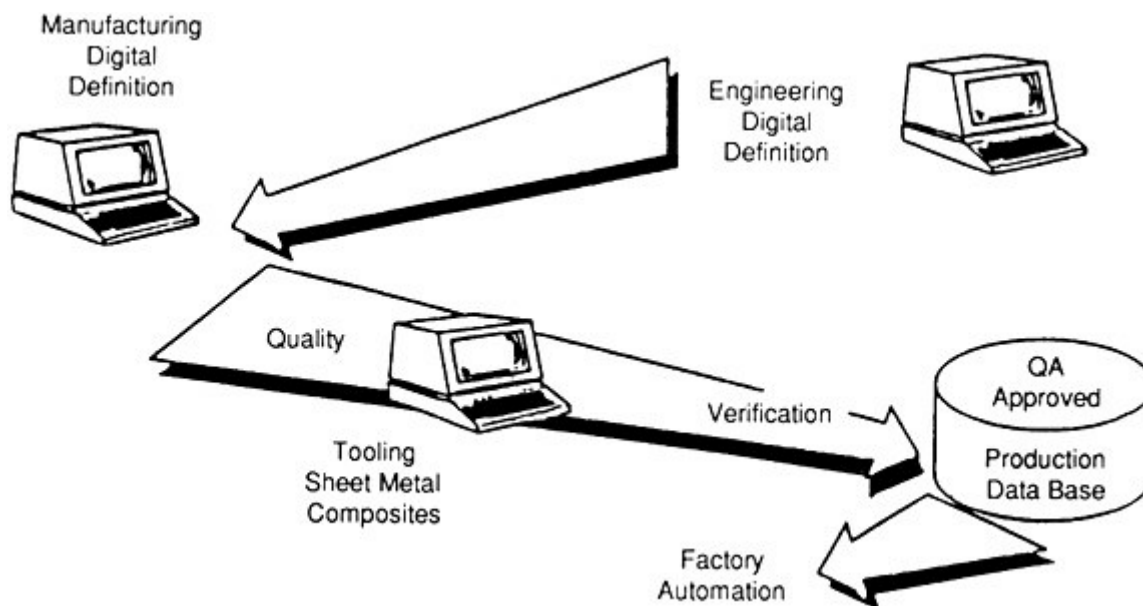

Figure B-5 Application of common electronic data base.

Shared information will be the common thread that will enhance quality and lower cost. An integrated data base for data flow in all directions is a method of achieving life-cycle engineering goals.

Shared information will also be the common thread in automated facilities for composite detail and co-cured parts plus subassembly and final assembly. Examples are the Integrated Composites Center (ICC), Automated Airframe Assembly Center (AAAC), Automated Machines Center and Cells, and Automated Sheet Metal Center and Cells now under development.

Shared information will be the common thread for totally integrated experience information storage and transfer to a central system (integrated data base) that controls need-to-know access.

Finally, shared information will be the common thread for an intelligent system that recognizes and flags recurring problems for upstream correction by use of imbedded rules, artificial intelligence systems, integrated data base for information flow, available computerized inspection data concerning initial part quality, and availability to user of analytical computer models, for overload, damage and repair support.

Having examined the present design environment and gazed into our crystal ball for a look at the idealized future environment, a set of unified life cycle engineering (ULCE) needs and concerns will be isolated for review and comparison with the critical issues identified by the committee.

ULCE needs and concerns for the horizontal stabilizer used in this case study are listed under headings according to the various product development phases:

### CONCEPTUAL DESIGN

1. Construct a complete experience-oriented analytical and operational expert system data base for the design engineer that includes all the human expert input on composite horizontal stabilizer and canard structure that is used today, including repairs.
2. Develop lightweight, low cost tooling for composite structure, including detail tools (hard and soft) and assembly tools (emphasizing co-cured opportunities).
3. Develop thermoplastic composites to improve repairability and reduce scrap.
4. Develop methods to embed reliability, maintainability, and supportability rules into generic CAD, CAM, CAL, and CAQA systems.
5. Develop an automated inspection system.
6. Embed analysis tools into CAD, CAM, and CAL systems for all downstream users to avoid delays for fixes and repairs.
7. Develop expanded digital capabilities necessary to maximize CAD, CAM, CAL, and CAQA impact on design, including color; large display (both quality and quantity of data) for reviews and for integration applications; solids modeling; interactive hardware library; interactive symbol library; features; and ability to handle nongeometric data (tolerances, finish, material and process information, notes, and effectiveness).

8. Share data via an integrated (common electronic) data base with downstream users for their inputs as early in the design cycle as feasible.

### **PROTOTYPE**

9. Develop and validate accurate models and simulation routines.
10. Develop expanded digital capabilities necessary to maximize impact of an EDF, including color, large display, solids modeling, and interactive hardware library.
11. Use integrated data base to flag areas of concern for further effort during full-scale development.
12. Use integrated data base to flag areas of opportunity during full-scale development, including robotics applications, numeric control and hybrid numeric control applications, concurring to reduce parts and fasteners, injection molding parts to minimize weight, reduce cost, and minimize galvanic corrosion, and forging, pressing, and casting applications.

### **FULL-SCALE DEVELOPMENT**

13. Develop artificial intelligence systems that can relate specific mission requirements to system and component histories and access the applicable portions of the integrated data base.
14. Develop artificial intelligence systems that can recognize and flag problems for corrective action.
15. Develop models of composite fabrication processes for automated processing.

### **PRODUCTION**

16. Institute factories of the future concept through completion and expansion of USAF programs to develop integrated centers for composites, machining, sheet metal, and assemblies.
17. Provide for interactive response to manufacturing problems to minimize delays and repairs.
18. Educate all users of the integrated data base in using its two-way flow of information.

### **OPERATION**

19. Implement routines for complete operational monitoring and feedback to the integrated data base.
20. Develop artificial intelligence systems that can recognize and flag recurring nonconformance records for correction where applicable via the integrated data base.

Having examined the present, gazed into the future and attempted to isolate needs and concerns, the single remaining task is to correlate the case study needs and concerns to the critical issues as identified by the committee.

Critical Issue 1: ULCE-driven development of materials processing and repair methodologies requires integration of R&D across disciplines.

Supporting Case Study Needs and Concerns: 1, 2, 3, 5, 6, 12, 14, 15, 19, 20

Critical Issue 2: Advanced analytical modeling and simulation methods to predict actual component manufacture, operation, and logistics do not exist to the degree required to preclude the need for physical prototypes and mock-ups.

Supporting Case Study Needs and Concerns: 5, 9, 10, 15

Critical Issue 3: The information system for an integrated team approach to ULCE is inadequate.

Supporting Case Study Needs and Concerns: 8, 12, 13, 17, 19

Critical Issue 4: The ULCE team will need to make key decisions while still operating with incomplete information.

Supporting Case Study Needs and Concerns: None.

## APPENDIX C

### PRESENTATIONS TO THE COMMITTEE

The committee received important perspectives in a number of areas from persons at universities, corporations, and government agencies. These persons are listed here along with some of their key points.

1. James Ashton, "Life-Cycle Engineering of Structural Components," Schlumberger Well Services, July 17, 1986

There is a clear distinction between design and manufacturing. The "ideal" design solution is a continuous, nonjointed structure that analysis shows has requisite load and stress supporting capability. However, continuous structures cannot be manufactured for several reasons—size, complexity, etc. Joints and attachments are difficult to analyze, test, manufacture, and maintain but are absolutely necessary from a supportability viewpoint. Cost reductions are most easily effected early in the design phase of a system (versus later in the purchase phase). The major life-cycle costs drivers are:

Acquisition costs 28 percent (design ~ 20 percent)

Operation costs 12 percent

Logistic support 60 percent (repair labor costs ~ 40 percent, spares replenishment ~ 10 percent)



2. L. A. Belady, "Software Life-Cycle Engineering," Micro Electronics and Computer Technology Corp., June 20, 1986

Life-cycle engineering of very large software systems (developed by more than one person per organization) is now becoming appreciated, reflecting the inevitability of software evolution—i.e., repairing (patching) as well as enhancement—due to new use requirements or advancing technology (new devices or codes). Most of the cost of software is devoted to maintenance activities. There appear to be parallels between ULCE of software and of structural components.

Complex software is developed in modules. Software engineering transforms fuzzy requirements (obtained in dialogue between user and software writer) into exact programs. At an intermediate stage, software requirements become formalized, and thereafter effort is focused on writing the programs. The bulk of software problems arise from incompatibility at interfaces between different modules. As modifications are made, one module may change in a different way than others. But compatibility among the modules is still essential. The time period from initial requirements to first modification may be a few months or years; this time increases with subsequent modifications as systems become more rigid. For different customers, the configuration of the software may be different.

3. Thomas Bennett, "ULCE Supportability Aircraft Structure," General Dynamics, July 17, 1986

Supportability requirements and consideration are different under peacetime and wartime conditions. The continuing goal for advanced military aircraft is to reduce the percentage of the total weight taken up by the structure. A key observation regarding supportability of aircraft is that the trend of maintenance man-hours per flight-hour is increasing substantially for the structural systems but decreasing for most other subsystems. However, the subsystems may fail in ways other than predicted, so that lack of capability to repair (e.g., not having a spare available) may cause greater loss of availability than repair time. The three top causes of loss of structural durability are cracking, corrosion, and maintenance-induced damage.

4. J. Coleman and Alan Herner, United States Air Force (USAF) Human Resources Laboratory, June 19, 1986

The ongoing Maintenance and Logistics in Computer-Aided Design program at the Air Force Human Resources Laboratory involves all three services as well as the Institute for Defense Analyses (IDA) and the National Security Industrial Association (NSIA). In the present design process, logistics (supportability) issues such as reliability and maintainability are normally addressed after design features for cost and performance are frozen. The objective of MLCAD is that supportability issues be addressed within the active design window by using computer-aided techniques. The enabling technologies rely on computer techniques, system networking, and integration. A survey by NSIA showed that cost of modification once manufacturing has started can be as much as a thousand times more than eliminating the problem in the design phase. Two examples of successful implementation of the MLCAD principles were given: (a) redesign of the Cruise Missile Launch System's generator to improve its reliability as well as access for maintenance and (b) simulation of the maintenance task required for the F-15 while it is in a shelter, to flag problems during that process.



5. Michael Dubberly, "Structural Life Management of Navy Aircraft," Naval Air Systems Command, September 29, 1986

For the Navy, the design point is the "severe usage spectrum," not the Air Force's criterion of "average use spectrum." This difference may lead to different weight requirements—e.g., for the F-18 fighter, the maximum fatigue load versus average requires an additional 100 pounds (a few percent of airframe weight). Note that additional weight and conservative design are key for the airframe (used for the life of the plane) but not for components that are changed frequently.

For graphite fiber-reinforced composites, at present, it is not possible to transfer laboratory test data to fleet performance as is done with metals because the lab test behavior of the composite is more environment-sensitive than that for metals. The composites are dependent on process controls during manufacturing, not post-manufacturing inspection, and a guaranteed material toughness is needed.

The design approach for fleet service allows no failures (cracks) in the design lifetime and requires that complete traceability of each plane's operations history be maintained. A case history for the wing of the A-6 aircraft indicated that a block test program showed the design to be conservative, yet a flight-by-flight test (all components on one plane tested) showed that the design was nonconservative.

6. Stephen Finger, "Turbine Disk Case History," Pratt & Whitney, July 17, 1986

Design considerations for the F-100 turbine engine were reviewed. The service environment is difficult to measure, and it is important to monitor centrifugal, thermal gas, bending, and vibrating stresses. Indeed, comparison of the qualification test with the predicted design mix and with the actual operation shows substantial differences—principally in cyclic power requirements (hence lowcycle fatigue properties).

The Pratt & Whitney design tools support group and review process were also discussed. Design criteria and verification are a composite of "lessons learned" based on engine requirements, past experience, and military specifications. Changes in configuration of a component and its resulting producibility—e.g., powder processing (gatorizing)—are checked with various groups, including engineering, product support, and the customer (the USAF—it provides data bases). The payoff of this interactive design approach has been that 97 percent of repairs are accomplished at base level, leading to rapid repairs. Two mechanisms to identify incipient problems are accelerated mission tests and "lead-the-fleet" pacers.

7. Dan Good, "Army Perspective on ULCE," U.S. Army Aviation Systems Command, June 19, 1986

The Army has the "Flight Safety Parts Surveillance Program" to ensure that design requirements are being met in use operation. Possible causes of a helicopter fatigue failure were discussed. These include (a) failure of related parts that indicated use outside the design spectrum; (b) critical part without fail-safe design; (c) the material used was notch-sensitive; (d) process controls were not adequate; (e) manufacturing changes were made without proper design considerations (feedback loop); and (f) analysis shortcomings. The ULCE approach might have identified the problem. Certainly, an information system could have been useful in gathering facts. But, even with a data base, a framework would be needed to use the information in a system-accept-or-reject capacity.

8. John Mayer, "Design, Manufacturing, and Computer Engineering Division Programs at NSF," National Science Foundation, June 20, 1986

Programs in the Design, Manufacturing, and Computer Engineering Division were described. For design and manufacture there are analysis methods available. A menu may be needed more than a model.

9. J. R. Meeker, "ULCE Promises a Return on Investment," U.S. Air Force, June 19, 1986

ULCE is one of two Forecast II initiatives where the Air Force is investing in its future base technology; the other is quality in manufacture. ULCE is needed to address the following: (a) weapon systems are being planned for 10-to 50-year lifetimes—i.e., the Air Force cannot afford to change its fleet; (b) new systems frequently need major modifications within the first year because the original design does not perform satisfactorily; (c) application of new technology is slow; and (d) logistics is done inefficiently. The Air Force strategy is to develop a government-industry consortium, advocate CAD, CAM, and CAS, integrate these, and use ULCE in applications by the year 2000.

ULCE near-term efforts are focusing on developing design tools and models for CAS to provide for interaction between CAS, CAD, and CAM tools and models and to integrate the design-assisting software into a decision-support system within the design environment. Long-term efforts include concentrating on the development of a technology base for the next generation of design systems to include cradle-to-grave management, reducing design to manufacturing lead time, reducing prototype requirements, and providing supportable design.

10. J. Stanley Mosier, "Case Study of a Metallic Gas Turbine Disk," G.E. Aircraft Engines, March 4, 1987

The subject case study of a metallic gas turbine disk (included in report as [Appendix A](#)), was conducted by the author in support of the committee's work to compare the results of a recent actual hardware design experience with generic ULCE needs and concerns that had been established by the committee. The high pressure turbine disk of the F110 augmented turbo fan engine was selected as a technically appropriate and timely example. As a product of this study, a checklist format relating life cycle engineering considerations to the functional engineering areas of materials, design, manufacturing assembly and test, and product support were developed. In addition, a list of specific life cycle engineering needs and concerns defined by the F110 HPTD design experience evolved. A comparison of the case study items identified, associated each with at least one of four critical issues defined by the committee. Through these comparisons this case study supported the validity and completeness of the generic critical issues developed by the committee.

11. D. Mulville, "Systems Effectiveness Definitions," NAVAIR (now with NASA)

Systems effectiveness definitions were given:

- **Operational Dependability**—the probability that the equipment, if up and ready at the beginning of a mission, is able to successfully complete the mission. Any in-flight anomaly (i.e., material failure, operability deficiency, or performance deficiency) that may result in a mission loss is an operational dependability problem.
- **Operational Capability**—the ability of the equipment to perform its intended mission. Operational capability problems degrade mission effectiveness but do not affect mission

completion. Normally these problems manifest themselves in the ability of the equipment to meet original specification performance.

- Operational Availability—the probability that the equipment is up and ready to perform as intended. Operational availability problems are normally the result of problems in equipment design, integrated logistic support, or both. Three additional definitions pertain:
- Reliability—the probability that an item can perform its intended function for a specified interval under stated conditions. Mean time between failure (MTBF) and component removals are indicators of equipment reliability.
- Maintainability—the ability to restore a system to an operational condition under specified logistics conditions. Mean time to repair (MTTR) is an indicator of the equipment's inherent maintainability.
- Supportability (Logistic Support)—the ability to satisfy the material, logistics, and mission requirements to restore the operation of failed or damaged equipment or components. An indicator of logistic support is mean downtime per failure (MDT). MDT is a function of two items: (1) the time necessary to repair a failed system at the organizational level and (2) the additional delay caused by the logistic support for the equipment (i.e., the time required to obtain a replacement part or material from the supply system and the time necessary to repair failed systems at the intermediate or depot level).
- Aircraft Survivability—the capability of an aircraft to avoid and/or withstand a hostile environment:  
Survivability =  $P_s = 1 - [\text{Vulnerability}] [\text{Susceptibility}]$
- Aircraft Vulnerability—the inability of an aircraft to withstand the damage caused by the hostile environment:  
Vulnerability =  $P_{k/h}$  (Probability of kill given a hit)
- Aircraft Susceptibility—the ability of an aircraft to avoid being damaged by the hostile environment:  
Susceptibility =  $P_h$  (Probability of hit)
- Aircraft Survivability Enhancement—any particular characteristic of the aircraft, specific piece of equipment, design technique, armament, or tactic that reduces either the susceptibility or the vulnerability of the aircraft and has the potential of increasing the survivability of the aircraft.

12. W. Reimann. "Unified Life-Cycle Engineering," AFWAL/MLTC, June 19, 1986

ULCE is ranked in the top ten items in Air Force Forecast 2000 and is viewed as the technical route to improved logistics support. The trend of Air Force programs in ULCE is toward the increasingly ambitious scope of integrating information for design and manufacturing operations. Enabling technologies above and on the shop floor are considered.

ULCE is viewed as the integration of three activities—CAD, CAM, and CAS/CAM. By the time 5 percent of the funds are actually spent, 85 percent has been committed. Hence there is great leverage in bringing more information into the design stage. Current programs on CAS reveal areas in components that cannot be inspected—i.e., probed with NDE methods. The question arises whether integrating CAD and CAM with CAS could yield components with better inspectability even if other performance factors are compromised—e.g., increased weight.

The development of ULCE requires a common data base. In contrast, today's Air Force (and its contractors) has separate data bases; for example, the Air Force Logistics Command found more than 660 data bases throughout the Air Force network. The problem arises in how to transmit data among different data bases. The Air Force wants to have a data representation protocol compatibility with different computer systems. Prior Air Force programs—ICAM, IDEF, and CIM—emphasized "above the shop floor" activities; programs include product definition data interface (PDDI) and geometrical modeling applications programs (GMAP). The ultimate goal is to develop a part definition standard.

13. Albert Russell, "Life-Cycle Enhancement of Electronic Systems," University of Massachusetts, June 20, 1986

In small electronic devices, 70 percent of the costs is associated with assembly. Three questions are asked regarding need for mechanical assembly of parts: Is there relative motion between the part and adjacent ones, must it be made of different material, and does it play an integral role in accessibility to other parts? For mechanical assembly, a design efficiency can be computed.

For printed circuit boards (PCBs), rules for defining whether a part can be eliminated have not (and perhaps cannot) be formulated. Proper assembly probably cannot be verified until the entire PCB has been fabricated.

14. Ken Taylor, "Life-Cycle Engineering of the F-16 Horizontal Stabilizer," General Dynamics, July 17, 1986

The horizontal stabilizer for the F-16 was modified to respond to three "needs": (a) improve pitch control at low-air-speed and high angle of attack situation, (b) shorten take-off distance, and (c) shorten landing roll. The first need was provided by pilots on the performance of the aircraft in dogfights. The modification was to fabricate the stabilizer as a built-up structure rather than a honeycomb bonded one. Lessons learned for design, manufacture, and product support maintainability were enumerated. In all cases, more information would have been helpful, but it is not clear that this could have been specified in advance.

15. Richard Wright, "National Engineering Laboratory Programs," National Institute of Standards and Technology (NIST), June 20, 1986

ULCE-related programs at the National Engineering Laboratory were reviewed with emphasis on the Center for Building Technology. Areas of interest are advanced measurement techniques, performance modeling and prediction, automation of building operating systems, and information interface technologies. Throughout these areas, the concern was raised regarding interfacing information across different communities and through the life cycle of the building. Also discussed was initial graphics exchange specifications (IGES). For the "construction" industry, the major technique for achieving reliability is fail-safe design—e.g., inelastic deformation of floors before failure. The time period from initial concept to completed building is 3 years with an excellent building team and 7 years average.

16. Brief program reviews were also given on Navy and NASA programs, as follows:  
Charles Zanis and Louis Sloter, "ULCE Navy Interests," Naval Sea Systems Command, June 19, 1986  
Richard Weinstein, "NASA Life-Cycle Engineering Areas of Interest," NASA, June 19, 1986

About this PDF file: This new digital representation of the original work has been recomposed from XML files created from the original paper book, not from the original typesetting files. Page breaks are true to the original; line lengths, word breaks, heading styles, and other typesetting-specific formatting, however, cannot be retained, and some typographic errors may have been accidentally inserted. Please use the print version of this publication as the authoritative version for attribution.

## APPENDIX D

# BIOGRAPHICAL SKETCHES OF COMMITTEE MEMBERS

**MICHAEL J. BUCKLEY** received his B.S. degree in chemistry from Michigan State University and his Ph.D. in physical chemistry from the University of California. Before joining Rockwell International in 1981, he was program manager, Defense Science Office, Defense Advanced Research Projects Agency, from 1977 to 1981 and group leader of the Nondestructive Evaluation Branch, Air Force Materials Laboratory, from 1972 to 1977. He is currently director of the Rockwell International Science Center, Palo Alto. He is a member of the American Physical Society, American Association for Artificial Intelligence, and Sigma Xi.

**JAMES K. BLUNDELL** received his B.Sc. from the University of Stanford, his M.S.C. from the University of Loughborough, and his Ph.D. from the University of Nottingham. In 1979 he joined the University of Missouri-Kansas City as an assistant professor and currently is Associate Professor of Mechanical and Aerospace Engineering. Prior academic associations have been with the University of the West Indies, Trinidad, and Nottingham University, England.

**RONALD C. FIX** majored in civil engineering at Washington University through 1955. Since 1955 he has worked for McDonnell Aircraft Company in various structural design capacities and is currently program manager for CAD/CAM at McDonnell Douglas Aircraft Company in St. Louis, Missouri.

**SIEGFRIED GOLDSTEIN** received his B.S.E.E. degree from the Cooper Union for the Advancement of Science and Art in 1961. After retiring from the AIL Division of the Eaton Corporation, he has headed his own engineering management consultant firm, Siegfried Enterprises, Inc., specializing in assessing of and assisting in electronic equipment design for supportability, availability, and readiness.



**CHARLES F. HERNDON** received his B.S. degree in aeronautical engineering from the University of Illinois in 1950. In 1950 he joined General Dynamics and at present is Director of Structures Design and Materials at the Fort Worth Division. He is a member of the American Institute of Aeronautics and Astronautics Technical Committee for Design Engineering Technical Committee for several years.

**RICHARD S. LOPATKA** received his B.S. degree in mathematics from the University of Massachusetts (1964) and his M.S. degree in mathematics from Rensselaer Polytechnic Institute (1967). His professional career with Pratt & Whitney began in 1964, where from 1964 to 1969 he was a structural engineer; from 1969 to 1983 he was supervisor, then manager, of Applications Systems. In 1982 and 1983 he was manager, CAD-CAM Systems, Engineering Division, from 1983 to 1986 manager, CAD/CAM and Tool Development; and since 1986 manager of CIM Technology and Tool Engineering.

**YOH-HAN PAO** received his undergraduate education at the Lester Institute in China (1945) with a B.Sc. from London University (External) and his Ph.D. degree in applied physics from Pennsylvania State University (1952). Since 1967 he has been at Case Western Reserve University, where he is Professor of Electrical Engineering and Computer Science. He is also the George S. Dively Distinguished Professor of Engineering. He was chairman of the Department of Electrical Engineering and Applied Physics from 1969 to 1977 and is currently director of the Center for Automation and Intelligent Systems Research. Before 1967, he held positions at Pennsylvania State University, E.I. duPont de Nemours & Company, University of Chicago, and AT&T Bell Laboratories. He is a fellow of the Institute of Electrical and Electronic Engineers and of the Optical Society of America, a member of the American Association for Artificial Intelligence, and the founder of AI Ware, Inc., in Cleveland.

**RALPH E. PATSFALL** received B.S. (1944) and M.S. (1947) degrees in metallurgical engineering from the University of Wisconsin and a J.D. degree (1949) from Marquette University. Since 1952 he has been associated with General Electric Company in the areas of materials and process engineering, metalworking, plant engineering, manufacturing technology, and manufacturing operations for aircraft engines and is at present chief manufacturing engineer for the GE Aircraft Engines Group. He is a member of the Society for Advancement of Materials and Process Engineering, Society of Manufacturing Engineers, and Society of Automotive Engineers.

**ROBIN STEVENSON** received his B.Sc. degree in metallurgy from Glasgow University and his Ph.D. in metallurgy from Massachusetts Institute of Technology. He joined General Motors Research Laboratory in 1973 and in 1983 transferred to General Motors Advanced Engineering Staff where he held several positions including program manager for the Computerized Major Tooling Program. In 1988 he rejoined General Motors Research Laboratories as a member of the Engineering Department. He is a member of the ASM INTERNATIONAL and the Metallurgical Society of AIME.

**EDISON T. S. TSE** received his B.S. and M.S. degrees simultaneously in 1967 and his Ph.D. degree in 1970 in electrical engineering from Massachusetts Institute of Technology. He is currently director of the Decision Systems Laboratory and associate professor in the Department of Engineering-Economic Systems at Stanford University. Before joining Stanford, he was senior research engineer at Systems Control Inc. in Palo Alto.

**DICK J. WILKINS** received his B.S. and M.S. degrees in aerospace engineering and Ph.D. in engineering science from the University of Oklahoma in 1969. From 1968 to 1985, he was associated with General Dynamics as an engineering staff specialist. He joined the University of Delaware in 1985 as director of the Center for Composite Materials and Professor of Mechanical

Engineering. He currently serves as president of the American Society for composites. He is also a member of the Society for the Advancement of Material and Process Engineering, American Society for Testing and Materials, Society of Plastic Engineers and the Society of Manufacturing Engineers.

**DAVID H. WITHERS** received his B.S. degree from the U.S. Coast Guard Academy and his M.S. degrees in mathematics and computer science from Rensselaer Polytechnic Institute. He served as a commissioned officer in the U.S. Coast Guard from 1962 to 1969. In 1969 he joined IBM as a mathematician in its components division. From 1973 to 1975 he was manager of Advanced Math and Engineering Analysis in the Systems Products Division and from 1975 to 1978 was senior mathematician in the Office Products Division. From 1979 through 1984 he served in various management positions. He was a research staff member and manager of Product and Process Analysis at IBM's T. J. Watson Research Center from 1985 to 1987. He is currently a senior planner for Computer Integrated Manufacturing applications with the Applications Systems Division in Atlanta, Georgia. He is a member of the Association for Computing Machinery, the Operations Research Society of America, and the Institute for Management Science.

**H. THOMAS YOLKEN** received his B.S. degree in metallurgy in 1960 and his Ph.D. degree in materials science in 1970 from the University of Maryland. Since 1960 he has held positions at the National Institute of Standards and Technology (NIST). He was research metallurgist (1960–1967); assistant to the director of Materials Sciences, Institute of Materials Research (1967–1970); deputy chief of the Office of Standard Reference Materials (1971–1975); manager of the NIST Office Measurements for Nuclear Technology Program (1976–1981); and since 1982 he has been the manager of the NIST Nondestructive Evaluation Program. He is a member of the American Physical Society, Alpha Sigma Mu, and the American Society for Nondestructive Testing.

About this PDF file: This new digital representation of the original work has been recomposed from XML files created from the original paper book, not from the original typesetting files. Page breaks are true to the original; line lengths, word breaks, heading styles, and other typesetting-specific formatting, however, cannot be retained, and some typographic errors may have been accidentally inserted. Please use the print version of this publication as the authoritative version for attribution.

UNCLASSIFIED  
 SECURITY CLASSIFICATION OF THIS PAGE

REPORT DOCUMENTATION PAGE				
1a. REPORT SECURITY CLASSIFICATION UNCLASSIFIED		1b. RESTRICTIVE MARKINGS NONE		
2a. SECURITY CLASSIFICATION AUTHORITY N/A		3. DISTRIBUTION/AVAILABILITY OF REPORT Approved for public release Distribution unlimited		
2b. DECLASSIFICATION/DOWNGRADING SCHEDULE N/A				
4. PERFORMING ORGANIZATION REPORT NUMBER(S) NDAB-455		5. MONITORING ORGANIZATION REPORT NUMBER(S)		
6a. NAME OF PERFORMING ORGANIZATION National Materials Advisory Board		6b. OFFICE SYMBOL (if applicable) NDAB	7a. NAME OF MONITORING ORGANIZATION Department of Defense/National Aeronautics and Space Administration	
6c. ADDRESS (City, State, and ZIP Code) 2101 Constitution Avenue, NW Washington, DC 20418		7b. ADDRESS (City, State, and ZIP Code) Washington, DC 20301		
8a. NAME OF FUNDING / SPONSORING ORGANIZATION See 7a		8b. OFFICE SYMBOL (if applicable)	9. PROCUREMENT INSTRUMENT IDENTIFICATION NUMBER MDA 903-89-K-0078	
8c. ADDRESS (City, State, and ZIP Code) Washington, DC 20301		10. SOURCE OF FUNDING NUMBERS		
	PROGRAM ELEMENT NO.	PROJECT NO.	TASK NO.	WORK UNIT ACCESSION NO.
11. TITLE (Include Security Classification) Enabling Technologies for Unified Life-Cycle Engineering of Structural Components				
12. PERSONAL AUTHOR(S) Committee on Same				
13a. TYPE OF REPORT one of a series under contract		13b. TIME COVERED FROM 1987 TO 1990	14. DATE OF REPORT (Year, Month, Day) 1991 March 22	15. PAGE COUNT 108
16. SUPPLEMENTARY NOTATION NONE				
17. COSATI CODES			18. SUBJECT TERMS (Continue on reverse if necessary and identify by block number)	
FIELD	GROUP	SUB-GROUP	Life-cycle engineering; weapons systems, structural materials; manufacturing, design and product support; information systems	
19. ABSTRACT (Continue on reverse if necessary and identify by block number)				
<p>This report addresses the application of unified life-cycle engineering approaches to the design, manufacture and application of structural components, especially structural components for advanced military weapons systems. Unified life-cycle engineering (ULCE), or concurrent engineering, is a design engineering environment in which computer-aided design technology is used to assess and improve the quality of a product not only during the active design phases but throughout its entire life cycle by integrating and optimizing design attributes for producibility and supportability as well as for performance, operability, cost, and schedule. The study identifies and evaluates priorities for research and development in life-cycle engineering with the goal of identifying the enabling technologies that underpin ULCE, their readiness for application, and the research and development required to make them commercially available in a 10-year period. The committee examined the current and desired future environments for five factors in a product's life cycle: design, manufacture, product support, materials, and information systems. Four critical issues are identified and conclusions and recommendations to support the development of an effective ULCE design engineering environment are defined.</p>				
20. DISTRIBUTION AVAILABILITY OF ABSTRACT <input checked="" type="checkbox"/> UNCLASSIFIED/ANN MITTD <input type="checkbox"/> SAME AS RPT <input type="checkbox"/> DTIC USERS			21. ABSTRACT SECURITY CLASSIFICATION Unclassified	
22a. NAME OF RESPONSIBLE INDIVIDUAL Jerome Persh			22b. TELEPHONE (Include Area Code) (202) 695-0005	22c. OFFICE SYMBOL OUSD&E/B&AT/MST

DD FORM 1473, 84 MAR

83 APR edition may be used until exhausted.  
 All other editions are obsolete.

SECURITY CLASSIFICATION OF THIS PAGE  
 UNCLASSIFIED

About this PDF file: This new digital representation of the original work has been recomposed from XML files created from the original paper book, not from the original typesetting files. Page breaks are true to the original; line lengths, word breaks, heading styles, and other typesetting-specific formatting, however, cannot be retained, and some typographic errors may have been accidentally inserted. Please use the print version of this publication as the authoritative version for attribution.