

Inspection and Maintenance of Bridge Stay Cable Systems

DETAILS

75 pages | | PAPERBACK

ISBN 978-0-309-09760-4 | DOI 10.17226/13689

AUTHORS

BUY THIS BOOK

FIND RELATED TITLES

Visit the National Academies Press at NAP.edu and login or register to get:

- Access to free PDF downloads of thousands of scientific reports
- 10% off the price of print titles
- Email or social media notifications of new titles related to your interests
- Special offers and discounts



Distribution, posting, or copying of this PDF is strictly prohibited without written permission of the National Academies Press. (Request Permission) Unless otherwise indicated, all materials in this PDF are copyrighted by the National Academy of Sciences.

NATIONAL COOPERATIVE HIGHWAY RESEARCH PROGRAM

NCHRP SYNTHESIS 353

**Inspection and Maintenance
of Bridge Stay Cable Systems**

A Synthesis of Highway Practice

CONSULTANT

HABIB TABATABAI

University of Wisconsin–Milwaukee

SUBJECT AREAS

Bridges, Other Structures and Hydraulics and Hydrology and Maintenance

Research Sponsored by the American Association of State Highway and Transportation Officials
in Cooperation with the Federal Highway Administration

TRANSPORTATION RESEARCH BOARD

WASHINGTON, D.C.

2005

www.TRB.org

NATIONAL COOPERATIVE HIGHWAY RESEARCH PROGRAM

Systematic, well-designed research provides the most effective approach to the solution of many problems facing highway administrators and engineers. Often, highway problems are of local interest and can best be studied by highway departments individually or in cooperation with their state universities and others. However, the accelerating growth of highway transportation develops increasingly complex problems of wide interest to highway authorities. These problems are best studied through a coordinated program of cooperative research.

In recognition of these needs, the highway administrators of the American Association of State Highway and Transportation Officials initiated in 1962 an objective national highway research program employing modern scientific techniques. This program is supported on a continuing basis by funds from participating member states of the Association and it receives the full cooperation and support of the Federal Highway Administration, United States Department of Transportation.

The Transportation Research Board of the National Academies was requested by the Association to administer the research program because of the Board's recognized objectivity and understanding of modern research practices. The Board is uniquely suited for this purpose as it maintains an extensive committee structure from which authorities on any highway transportation subject may be drawn; it possesses avenues of communications and cooperation with federal, state, and local governmental agencies, universities, and industry; its relationship to the National Research Council is an insurance of objectivity; it maintains a full-time research correlation staff of specialists in highway transportation matters to bring the findings of research directly to those who are in a position to use them.

The program is developed on the basis of research needs identified by chief administrators of the highway and transportation departments and by committees of AASHTO. Each year, specific areas of research needs to be included in the program are proposed to the National Research Council and the Board by the American Association of State Highway and Transportation Officials. Research projects to fulfill these needs are defined by the Board, and qualified research agencies are selected from those that have submitted proposals. Administration and surveillance of research contracts are the responsibilities of the National Research Council and the Transportation Research Board.

The needs for highway research are many, and the National Cooperative Highway Research Program can make significant contributions to the solution of highway transportation problems of mutual concern to many responsible groups. The program, however, is intended to complement rather than to substitute for or duplicate other highway research programs.

NOTE: The Transportation Research Board of the National Academies, the National Research Council, the Federal Highway Administration, the American Association of State Highway and Transportation Officials, and the individual states participating in the National Cooperative Highway Research Program do not endorse products or manufacturers. Trade or manufacturers' names appear herein solely because they are considered essential to the object of this report.

NCHRP SYNTHESIS 353

Project 20-5 FY 2003 (Topic 35-07)
 ISSN 0547-5570
 ISBN 0-309-09760-6
 Library of Congress Control No. 2005933207

© Transportation Research Board

Price \$17.00

NOTICE

The project that is the subject of this report was a part of the National Cooperative Highway Research Program conducted by the Transportation Research Board with the approval of the Governing Board of the National Research Council. Such approval reflects the Governing Board's judgment that the program concerned is of national importance and appropriate with respect to both the purposes and resources of the National Research Council.

The members of the technical committee selected to monitor this project and to review this report were chosen for recognized scholarly competence and with due consideration for the balance of disciplines appropriate to the project. The opinions and conclusions expressed or implied are those of the research agency that performed the research, and, while they have been accepted as appropriate by the technical committee, they are not necessarily those of the Transportation Research Board, the National Research Council, the American Association of State Highway and Transportation Officials, or the Federal Highway Administration, U.S. Department of Transportation.

Each report is reviewed and accepted for publication by the technical committee according to procedures established and monitored by the Transportation Research Board Executive Committee and the Governing Board of the National Research Council.

Published reports of the

NATIONAL COOPERATIVE HIGHWAY RESEARCH PROGRAM

are available from:

Transportation Research Board
 Business Office
 500 Fifth Street, NW
 Washington, DC 20001

and can be ordered through the Internet at:

<http://www.national-academies.org/trb/bookstore>

Printed in the United States of America

THE NATIONAL ACADEMIES

Advisers to the Nation on Science, Engineering, and Medicine

The **National Academy of Sciences** is a private, nonprofit, self-perpetuating society of distinguished scholars engaged in scientific and engineering research, dedicated to the furtherance of science and technology and to their use for the general welfare. On the authority of the charter granted to it by the Congress in 1863, the Academy has a mandate that requires it to advise the federal government on scientific and technical matters. Dr. Ralph J. Cicerone is president of the National Academy of Sciences.

The **National Academy of Engineering** was established in 1964, under the charter of the National Academy of Sciences, as a parallel organization of outstanding engineers. It is autonomous in its administration and in the selection of its members, sharing with the National Academy of Sciences the responsibility for advising the federal government. The National Academy of Engineering also sponsors engineering programs aimed at meeting national needs, encourages education and research, and recognizes the superior achievements of engineers. Dr. William A. Wulf is president of the National Academy of Engineering.

The **Institute of Medicine** was established in 1970 by the National Academy of Sciences to secure the services of eminent members of appropriate professions in the examination of policy matters pertaining to the health of the public. The Institute acts under the responsibility given to the National Academy of Sciences by its congressional charter to be an adviser to the federal government and, on its own initiative, to identify issues of medical care, research, and education. Dr. Harvey V. Fineberg is president of the Institute of Medicine.

The **National Research Council** was organized by the National Academy of Sciences in 1916 to associate the broad community of science and technology with the Academy's purposes of furthering knowledge and advising the federal government. Functioning in accordance with general policies determined by the Academy, the Council has become the principal operating agency of both the National Academy of Sciences and the National Academy of Engineering in providing services to the government, the public, and the scientific and engineering communities. The Council is administered jointly by both the Academies and the Institute of Medicine. Dr. Ralph J. Cicerone and Dr. William A. Wulf are chair and vice chair, respectively, of the National Research Council.

The **Transportation Research Board** is a division of the National Research Council, which serves the National Academy of Sciences and the National Academy of Engineering. The Board's mission is to promote innovation and progress in transportation through research. In an objective and interdisciplinary setting, the Board facilitates the sharing of information on transportation practice and policy by researchers and practitioners; stimulates research and offers research management services that promote technical excellence; provides expert advice on transportation policy and programs; and disseminates research results broadly and encourages their implementation. The Board's varied activities annually engage more than 5,000 engineers, scientists, and other transportation researchers and practitioners from the public and private sectors and academia, all of whom contribute their expertise in the public interest. The program is supported by state transportation departments, federal agencies including the component administrations of the U.S. Department of Transportation, and other organizations and individuals interested in the development of transportation. www.TRB.org

www.national-academies.org

NCHRP COMMITTEE FOR PROJECT 20-5

CHAIR

GARY D. TAYLOR, *CTE Engineers*

MEMBERS

THOMAS R. BOHUSLAV, *Texas DOT*

DONN E. HANCHER, *University of Kentucky*

DWIGHT HORNE, *Federal Highway Administration*

YSELA LLORT, *Florida DOT*

WESLEY S.C. LUM, *California DOT*

JAMES W. MARCH, *Federal Highway Administration*

JOHN M. MASON, JR., *Pennsylvania State University*

CATHERINE NELSON, *Oregon DOT*

LARRY VELASQUEZ, *New Mexico DOT*

PAUL T. WELLS, *New York State DOT*

FHWA LIAISON

WILLIAM ZACCAGNINO

TRB LIAISON

MARK R. NORMAN

COOPERATIVE RESEARCH PROGRAM STAFF

ROBERT J. REILLY, *Director, Cooperative Research Programs*

CRAWFORD F. JENCKS, *Manager, NCHRP*

EILEEN DELANEY, *Director of Publications*

NCHRP SYNTHESIS STAFF

STEPHEN R. GODWIN, *Director for Studies and Information Services*

JON WILLIAMS, *Manager, Synthesis Studies*

DONNA L. VLASAK, *Senior Program Officer*

DON TIPPMAN, *Editor*

CHERYL KEITH, *Senior Secretary*

TOPIC PANEL

DARRELL K. DUDGEON, *Kentucky Transportation Cabinet*

GILL GAUTREAU, *Louisiana Department of Transportation and
Development*

AL GHORBANPOOR, *University of Wisconsin–Milwaukee*

DAVID GOODYEAR, *T.Y. Lin International*

FRANK N. LISLE, *Transportation Research Board*

STEPHEN E. PUTZ, *Illinois Department of Transportation*

KEITH L. RAMSEY, *Texas Department of Transportation*

JOHN TUNG, *Florida Department of Transportation*

HAROLD BOSCH, *Federal Highway Administration (Liaison)*

BENJAMIN M. TANG, *Federal Highway Administration (Liaison)*

FOREWORD

*By Staff
Transportation
Research Board*

Highway administrators, engineers, and researchers often face problems for which information already exists, either in documented form or as undocumented experience and practice. This information may be fragmented, scattered, and unevaluated. As a consequence, full knowledge of what has been learned about a problem may not be brought to bear on its solution. Costly research findings may go unused, valuable experience may be overlooked, and due consideration may not be given to recommended practices for solving or alleviating the problem.

There is information on nearly every subject of concern to highway administrators and engineers. Much of it derives from research or from the work of practitioners faced with problems in their day-to-day work. To provide a systematic means for assembling and evaluating such useful information and to make it available to the entire highway community, the American Association of State Highway and Transportation Officials—through the mechanism of the National Cooperative Highway Research Program—authorized the Transportation Research Board to undertake a continuing study. This study, NCHRP Project 20-5, “Synthesis of Information Related to Highway Problems,” searches out and synthesizes useful knowledge from all available sources and prepares concise, documented reports on specific topics. Reports from this endeavor constitute an NCHRP report series, *Synthesis of Highway Practice*.

This synthesis series reports on current knowledge and practice, in a compact format, without the detailed directions usually found in handbooks or design manuals. Each report in the series provides a compendium of the best knowledge available on those measures found to be the most successful in resolving specific problems.

PREFACE

This synthesis identifies and explains various inspection and maintenance techniques for bridge stay cable systems. It discusses both short- and long-term approaches. Topics covered included methods for inspections and assessments, including nondestructive testing and evaluation procedures; repair and retrofit; methods for control of cable vibrations, including rain–wind vibrations; stay cable fatigue and failure; effectiveness of various inspection and repair methods; limitations of available technologies; and trends and recommendations for future study.

This synthesis effort was based on a comprehensive review of domestic and international literature on the inspection, repair, testing, and design of stay cable. On-line sources of information as well as engineering databases were examined. A questionnaire was distributed to all state and provincial departments of transportation in the United States and Canada to determine current state of the practice. Also, contacts were made with a number of knowledgeable individuals for information. Additional information was gathered from the examination of test reports and condition assessments from inspections of cable-stayed bridges, a review of a limited number of maintenance and inspection manuals for cable-stayed bridges, and a patent search using the U.S. Patent and Trademark Office database.

Habib Tabatabai, University of Wisconsin–Milwaukee, collected and synthesized the information and wrote the report. The members of the topic panel are acknowledged on the preceding page. This synthesis is an immediately useful document that records the practices that were acceptable within the limitations of the knowledge available at the time of its preparation. As progress in research and practice continues, new knowledge will be added to that now at hand.

CONTENTS

1	SUMMARY
3	CHAPTER ONE INTRODUCTION Background, 3 Objectives and Scope, 4 Questionnaire, 5
8	CHAPTER TWO STAY CABLE SYSTEMS AND MATERIALS Stay Cable Systems, 8 Stay Cable Materials, 13 Stay Cable Design Challenges, 22 Fabrication and Erection of Stay Cables, 36
37	CHAPTER THREE INSPECTION AND MONITORING TECHNIQUES Short-Term Evaluation and Monitoring, 37 Long-Term Evaluation and Monitoring, 46
50	CHAPTER FOUR MAINTENANCE AND REPAIR OF STAY CABLES Repair and Retrofit Strategies and Methods, 50 Mitigation of Stay Cable Vibrations, 51 Challenges in Maintenance, Repair, and Retrofit, 58
59	CHAPTER FIVE FUTURE TRENDS
60	CHAPTER SIX CONCLUSIONS AND FUTURE RESEARCH NEEDS
63	REFERENCES
68	APPENDIX A SURVEY QUESTIONNAIRE
72	APPENDIX B STATISTICAL ANALYSIS OF SURVEY RESULTS

INSPECTION AND MAINTENANCE OF BRIDGE STAY CABLE SYSTEMS

SUMMARY In this synthesis effort, a worldwide search of information on inspection, repair, testing, and design of stay cable, was undertaken. On-line sources of information as well as engineering databases were examined. Contacts were made with a number of knowledgeable individuals for information. A questionnaire was prepared and distributed to all state and provincial departments of transportation in the United States and Canada. Completed questionnaires were received from 75% (27 of 36) of all known U.S. cable-stayed bridges and 81% (13 of 16) known cable-stayed bridges in Canada. Based on this information, various methods, approaches, and practices are explained in detail and their strengths and weaknesses identified. Specific approaches to inspection and repair are presented and discussed.

Challenges in the inspection and maintenance of cable-stayed bridges are significant. The main tension elements (MTEs) within a cable bundle are, in most cases, hidden from the view of inspectors. Access to cables for visual inspections or nondestructive testing is generally difficult and, in the case of the anchorage zones, nearly impossible. Those who are responsible for the inspection and maintenance of stay cables are faced with challenges for which proven and accepted methodologies and tools are limited and, in many cases, very costly.

There are 36 cable-stayed bridges in the United States and 16 such bridges in Canada. As of 2005, the average age of cable-stayed bridges in the United States was 11.4 years. As these bridges age, the need for effective inspection and maintenance methods and tools becomes more acute.

The following list cites some of the issues involved in the inspection, maintenance, and repair of stay cables, presents methods identified in the literature to address these issues, and briefly summarizes their known pros and cons and other factors. Detailed descriptions and discussions of these methods are given throughout this report.

General inspections (visual)—Visual inspections are, in the great majority of cases, the only method used for cable-stayed bridges.

Assessment of MTE condition in free length (magnetic flux leakage)—This system has a long history in the inspection of industrial cables and ropes.

Assessment of MTE condition (cable force measurements)—This approach is the most widely used, and sometimes misunderstood, nondestructive evaluation method.

Assessment of MTE condition (ultrasonic testing)—This method has been used on a few bridges to evaluate the condition of MTEs in Hi-Am-type anchorages.

Assessment of MTE condition (radiography)—Theoretically, this method has the potential to successfully assess conditions of cable anchorages where there is access to the perimeter.

Detection of wire breaks as they happen (acoustic monitoring)—Test laboratories performing qualification fatigue tests of stay cables have long used this method to detect wire breaks in the cable specimens as they happen.

Detection of grout voids inside high-density polyethylene (HDPE) pipe sheathing (impulse radar)—Hand-held impulse radar equipment can be placed over the cable and moved longitudinally to identify potential grout voids inside the cable sheathing.

Repair of large grout voids (vacuum grouting)—This method has long been used in post-tensioning tendon applications.

Cable force measurements (vibration-based using laser vibrometer)—A laser vibrometer is used to measure small vibrations of the cable from a large distance.

Cable force measurements (vibration-based using accelerometer)—Similar to the laser-based method described previously.

Cable force measurements (based on measurement of cable sag)—Although the tension in a cable is related to the square of the fundamental frequency, it is also inversely proportional to the cable sag; therefore, measurements of the cable sag can also be used to estimate cable tension.

Detection of hidden splits in HDPE (infrared thermography)—Hand-held infrared thermography equipment can be used to detect splits in HDPE pipes that are hidden under the protective tape.

Detection of damage to polyvinyl fluoride tape (infrared thermography)—Similar to the method discussed for the detection of hidden splits in HDPE.

Assessment of cable vibrations (long-term monitoring using accelerometers)—When cable vibration problems are suspected, sensors (accelerometers) can be mounted on select cables to monitor vibrations over a period of several weeks, months, or years.

Assessment of cable vibrations (video cameras on bridge)—There are no known instances of using video cameras to monitor vibrations on cable-stayed bridges. This option was discussed for two bridges in the path of hurricanes, but was not implemented.

Assessment of cable damping (vibration decay method)—There are different approaches to measuring cable damping. In one, an accelerometer is first attached on the cable.

There is no single method that would provide answers for all the questions regarding the condition of stay cables. In most cases, it is the combination of nondestructive testing techniques together with the experience, knowledge, and judgment of engineers, inspectors, and technicians that could lead to the appropriate answer. The effectiveness and accuracy of many of the methods might be significantly enhanced if baseline comparative measurements are available when the bridge is known to be defect free.

CHAPTER ONE

INTRODUCTION

BACKGROUND

With the popularity and rapid growth in the use of cable-stayed bridges in the United States and worldwide, issues related to inspection and maintenance of stay cables are taking on added significance. Examples of problems that could affect stay cable performance include excessive vibrations, corrosion, fatigue, and the general inability to reliably ascertain the internal condition of the cables, especially in the critical anchorage zones. Many of the assessment and repair methods are still in early development and information on reliable, proven techniques is not readily available. Bridge owners and engineers are faced with selecting and using a number of new technologies or approaches for cable assessments without the benefit of knowing their degree of effectiveness. Although some valuable data are available, they are generally not readily accessible. Therefore, this synthesis project aims to collect and synthesize such information into a single document.

Cable-stayed and suspension bridges are the two prominent types of cable-supported bridges. In both systems, cables are supported on pylons. In cable-stayed bridges, the cables are inclined and directly support the deck on the pylon(s). In suspension bridges, vertical suspender cables transfer loads from the deck to the main catenary-shaped cables. The main cables in suspension bridges are typically anchored at massive anchorages at the two ends of the bridge, whereas stay cables are anchored to the deck itself.

In their basic form and concept, cable-stayed bridges have existed for centuries. In 1823, French engineer C.L. Navier presented some of his concepts for bridges supported by wrought iron chains, as shown in Figure 1 (Gimsing 1999). Although these sketches strikingly resemble the modern cable-stayed bridges, Navier envisioned ground-anchored backstays only.

The next phase involved design of combined suspension and stayed systems. A prominent example is the Brooklyn Bridge, designed in the 19th century by John A. Roebling. The first modern cable-stayed bridge was the Strömsund Bridge built in 1955 in Sweden, which was designed by Franz Dischinger. It had a main span of 182.6 m (599 ft) (Gimsing 1999).

The first major cable-stayed bridge made of concrete pylons and girders was the Maracaibo Bridge in Venezuela, built in 1962. As will be discussed later in this report, the cables of this bridge were subsequently replaced as a result of corrosion.

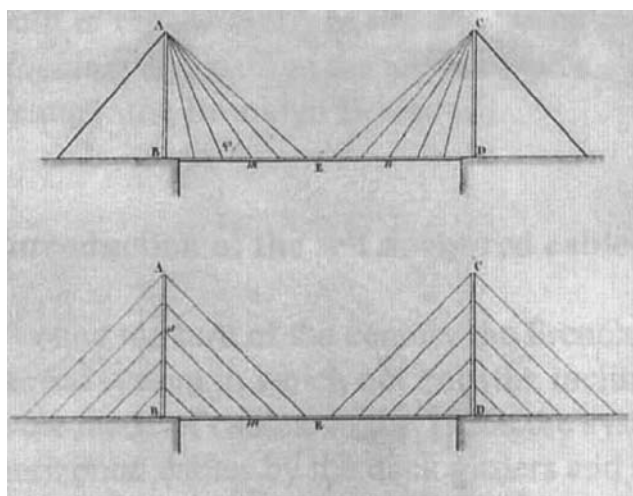

FIGURE 1 Bridge systems envisioned by Navier (Gimsing 1999).

The early bridges all had only a few stay cables, which provided support at locations where piers would have otherwise existed (Walther et al. 1999). This concept of using cables with large spacing did not fully realize the structural (and economic) potential of cable-stayed bridges. In 1967, H. Homberg used closely spaced stays (or the multi-stay system) on the Friedrich Ebert Bridge in Germany (Walther et al. 1999). The Brotonne Bridge in France used closely spaced stays, and the cable system was based on post-tensioning technology in which parallel seven-wire strands were encased in steel pipes and grouted (Gimsing 1999). The Zarate–Brazo Largo Bridges in Argentina were the first cable-stayed bridges designed to carry railroad and automobile traffic. As will be discussed later, one of the Argentine bridges had a complete failure of one of the stays after fewer than 20 years of service.

The oldest cable-stayed bridge in the United States is the Sitka Harbor Bridge in Alaska, built in 1970 (see Figure 2). The oldest cable-stayed bridge in North America is believed to be the North Romaine River railroad bridge in Québec, Canada, which was built in 1960. The oldest highway cable-stayed bridges in Canada are the Longs Creek #1 and Hawkshaw bridges in New Brunswick, built in 1966 and 1967, respectively. Other early and prominent cable-stayed bridges in North America include the Papineau Bridge in Montreal (1969) and the Pasco–Kennewick Bridge in Washington State (1978).



FIGURE 2 Sitka Harbor Bridge in Alaska, the oldest cable-stayed bridge in the United States (Frank and Breen 2004).

The pace of construction of new cable-stayed bridges in the United States grew rapidly in the 1990s and early 2000s. Today, cable-stayed bridges have entirely replaced truss bridges on new medium- to long-span crossings. For example, all new crossings of the Mississippi River in the last 15 to 20 years have been with cable-stayed bridges, whereas these spans were exclusively truss bridges before that time. The essential factor is the cost-effectiveness of the system, aided by its elegance.

The total number of cable-stayed bridges in the United States recently surpassed 35, with several other bridges in planning or under construction. These include bridges in the planning stages in New York City, St. Louis, and one spanning the Mississippi River between Mississippi and Arkansas. The St. Louis bridge, if implemented, would have a main span of 610 m (2,000 ft), and will be the longest cable-stayed span in the Western Hemisphere (Brown 2001b). The world record for cable size will belong to the Maumee River Bridge in Toledo, Ohio, scheduled for completion in late 2006 (DSI 2004). This bridge incorporates stays with 156 seven-wire strands 15.2 mm (0.6 in.) in diameter and cable diameters of up to 508 mm (20 in.) (Marsh 2003). The longest span cable-stayed bridge in the world is the Tatara Bridge in Ehime, Japan, with a main span of 890 m (2,920 ft). However, the Stonecutters Bridge in Hong Kong will surpass Tatara with a span of 1018 m (3,339 ft) when it is completed in 2008 (Brown 2001a).

The Millau Bridge in France (Viaduc de Millau) is the world's tallest bridge and spans France's Tarn River Valley. It consists of multiple cable-stayed spans with span lengths of approximately 340 m and a total length of approximately 2.5 km. The deck is approximately 270 m above the valley and the pylons reach 343 m above the ground.

The challenges in inspection and maintenance of cable-stayed bridges are enormous. The main tension elements (MTEs) within a cable bundle are, in most cases, hidden from the view of inspectors. Access to cables for visual inspections or nondestructive testing (NDT) is generally difficult, and in

the case of the anchorage zones, nearly impossible. Those who are tasked with the inspection and maintenance of stay cables face challenges for which proven and accepted methodologies and tools are limited and often very costly. For example, the internal deterioration and failure of an Argentine stay cable in 1996 was not detected beforehand by visual means.

This synthesis report will present the latest information available on inspection and maintenance of stay cables, explains various tools and methods available, and examines their track record or future potential in addressing stay cable evaluations. To better understand the applicability and complexities of various methods and approaches, a brief overview of different stay cable designs and materials is also presented.

OBJECTIVES AND SCOPE

The objective of this synthesis is to identify and explain effective and promising inspection and maintenance techniques for stay cables in cable-stayed bridges. Both short- and long-term approaches are discussed. This synthesis is based on the following:

- A comprehensive review of domestic and international literature to identify various techniques and their track records, as well as documented problems and case studies;
- Formal and informal surveys of state and provincial departments of transportation (DOTs) in the United States and Canada, cable suppliers, testing companies, bridge designers, researchers, and contractors to determine the current state of practice and identify future trends in condition assessments and repair and retrofit of stay cables. These surveys were conducted by means of a questionnaire and through meetings, telephone conversations, and e-mail exchanges with knowledgeable individuals;
- Examination of test reports and condition assessment results from major inspections and cable-stayed bridges;
- Review of a limited number of maintenance and inspection manuals for cable-stayed bridges; and
- A patent search using the U.S. Patent and Trademark Office database.

This synthesis includes the following types of information:

- Methods for inspections and assessments including NDT methods,
- Repair methods,
- Methods for control of cable vibrations including rain-wind vibrations,
- Control of moisture from internal or external sources,
- Fatigue in stay cables,
- Case studies of stay cable failures,
- Repair and retrofit issues and details,
- Effectiveness and costs of various inspection and repair methods,
- Limitations of available technologies,

- Future trends and promising technologies, and
- Recommendations for future research.

QUESTIONNAIRE

A questionnaire (see Appendix A) was prepared and distributed to all state and provincial DOTs in the United States and Canada. The same questionnaire was also sent to all members of the Post-Tensioning Institute’s (PTI) Cable-Stayed Bridge Committee, as well as major U.S. and Mexican stay cable suppliers and testing companies. Table 1 cites those states and provinces that responded and the number of bridges reported by each agency. A completed questionnaire was also received from one stay cable supplier. Table 2 is a list of all known cable-stayed bridges in the United States and Canada. The information contained in the completed surveys, published literature, a paper by Podolny (1992), and a report by Kumarasena et al. (2004) were used to assemble this list.

In the United States, 43 state DOTs (86%) responded to the survey, 24 of which did not have any cable-stayed bridges under their jurisdiction. One city (Milwaukee, Wisconsin) is maintaining two recently completed cable-stayed bridges. A completed questionnaire for one of the two new cable-stayed bridges in Ohio (Maumee River Bridge) was provided by the designer of the bridge.

A completed survey for one of the two cable-stayed bridges in Florida, the Dame Point Bridge in Jacksonville, was received. In addition, the Indiana DOT provided responses on two bridges, one a cable-stayed bridge and the other an arch bridge that incorporated stay cables. Table 1 lists only one cable-stayed bridge in Indiana, but the analyses of questionnaire results include both Indiana bridges.

In the United States, completed questionnaires were received for 75% of all known cable-stayed bridges (i.e., 27 of 36 cable-stayed bridges, with one additional arch bridge). It should be noted that four of the bridges listed in the U.S. inventory are pedestrian bridges. Therefore, the responses covered 84% of all highway bridges in the United States. No responses on U.S. pedestrian bridges were received. Questionnaires were not received for several other major cable-stayed bridges in the United States including the Sunshine Skyway Bridge in Florida, two bridges in West Virginia (East Huntington and Weirton–Steubenville), and the recently completed La Plata River Bridge in Puerto Rico.

In Canada, responses were obtained from 5 of the 13 provinces, representing 13 of the 16 known cable-stayed bridges in Canada (81%). The five cable-stayed bridges in Alberta/Calgary are all pedestrian bridges. Responses were not received for the ALRT Fraser River Bridge in British Columbia, and Bridge of the Isles and North Romaine railroad bridge in Quebec. In some states and Canadian provinces, different agencies controlled maintenance of different cable-stayed bridges, thus making the task of identifying the proper agencies difficult.

TABLE 1
SUMMARY OF RESPONSES RECEIVED FROM STATES/
PROVINCES IN THE UNITED STATES AND CANADA

States/Provinces	Response Received	No. of Bridges Reported	States/Provinces	Response Received	No. of Bridges Reported
United States					
Alabama	Y	1	Missouri	Y	1
Alaska	Y	2	Mississippi ^a	—	0
Arizona	Y	0	Montana	Y	0
Arkansas ^a	—	1	North Carolina	Y	0
California	Y	1 ^f	North Dakota	Y	0
Colorado	Y	0 ^c	New Hampshire	Y	0
Connecticut	Y	0	New Jersey	Y	0
Delaware	Y	1	New Mexico	Y	0
Florida ^b	—	1	Nevada	Y	0
Georgia	Y	2	New York	Y	0
Hawaii	Y	0	Ohio ^c	—	2
Idaho	Y	0	Pennsylvania	Y	0
Illinois	Y	2	Rhode Island	Y	0
Indiana	Y	2	South Carolina	Y	1
Iowa	Y	1	Tennessee	Y	0
Kansas	Y	0	Texas	Y	2
Kentucky	Y	2	Utah	Y	0
Louisiana	Y	1	Virginia	Y	1
Massachusetts	Y	1	Washington	Y	2
Maryland	Y	0	Wisconsin	Y	2
Michigan	Y	0	Wyoming	Y	0
Minnesota	Y	0			
Canada					
Alberta/Calgary ^d	—	5	New Brunswick	Y	3
British Columbia	Y	1	Ontario	Y	0
Manitoba/ Winnipeg	Y	1	Québec	Y	3

^a Mississippi and Arkansas share a bridge that is under construction and will be maintained by Arkansas.

^b The survey for one of the two Florida cable-stayed bridges was received.

^c The Ohio DOT reported two cable-stayed bridges under construction and the questionnaire for one bridge was received.

^d All cable-stayed bridges reported for Calgary in Alberta, Canada, are pedestrian bridges.

^e There are two pedestrian cable-stayed bridges in downtown Denver, Colorado. Information was not available on these bridges at the time of the writing of this report.

^f There is a pedestrian cable-stayed bridge in Redding, California. Information for this bridge became available only after the completion of this report

Using the data in Table 2, Figures 3 and 4 show the number of cable-stayed bridges built (i.e., opened to traffic) in the United States and Canada from 1955 to 2005 in 10-year increments. In the United States, there has been a substantial increase in the number and the rate of construction of cable-stayed bridges. From 1996 to 2005, 17 cable-stayed bridges were built in the United States, representing 47% of all such bridges built since 1970. The average age of cable-stayed bridges in the U.S. inventory (as of 2005) was 11.4 years, whereas the average age in Canada was 27 years.

The early Canadian bridge, the 217-m Hawkshaw Bridge built in 1967, had galvanized bridge strands with the stay cable wrapped with galvanized wire 5 ft above the deck and then coated with protective paste. This approach is somewhat

TABLE 2
 CABLE-STAYED BRIDGES IN THE UNITED STATES AND CANADA

No.	Bridge Name	State	Span, m (ft)	Year
United States				
1	Cooper River Bridge	South Carolina	472 (1,546)	2005
2	Greenville Bridge, US 82 over Mississippi	Mississippi	420 (1,378)	2005
3	Dame Point Bridge	Florida	397 (1,300)	1989
4	Fred Hartman/Houston Ship Channel	Texas	381 (1,250)	1995
5	Sidney Lanier Bridge, Brunswick	Georgia	381 (1,250)	2003
6	Hale Boggs/Luling Bridge	Louisiana	373 (1,222)	1984
7	Sunshine Skyway Bridge	Florida	366 (1,200)	1987
8	William Natcher/Owensboro Bridge	Kentucky	366 (1,200)	2002
9	Bill Emerson/Cape Girardeau Bridge	Missouri	351 (1,150)	2003
10	Talmadge Memorial Bridge, Savannah	Georgia	336 (1,100)	1991
11	William Harsha Bridge, Maysville	Kentucky	320 (1,050)	2000
12	Pasco–Kennewick Bridge, Gum Street	Washington	299 (981)	1978
13	East Huntington Bridge	West Virginia	275 (900)	1985
14	Quincy/Bayview Bridge	Illinois	275 (900)	1986
15	US Grant, Portsmouth	Ohio	267 (875)	2004
16	Weirton–Steubenville	West Virginia	250 (820)	1990
17	Cochrane Africatown Bridge	Alabama	238 (780)	1991
18	Clark Bridge, Alton	Illinois	230 (756)	1994
19	C&D Canal Bridge	Delaware	229 (750)	1995
20	L.P. Zakim Bunker Hill, Charles River	Massachusetts	227 (745)	2002
21	Burlington Bridge, Burlington	Iowa	201 (660)	1995
22	Veterans Memorial/Neches River Bridge	Texas	195 (640)	1991
23	Varina–Enon Bridge/James River	Virginia	192 (630)	1990
24	Maumee River Crossing	Ohio	187 (613)	2005
25	PR 148 over LaPlata River	Puerto Rico	160 (525)	2005
26	SR 46/East Fork White River	Indiana	142 (466)	1999
27	Sitka Harbor/John O’Connel Bridge	Alaska	137 (450)	1970
28	Tea Foss Waterway Bridge, Tacoma	Washington	114 (375)	1996
29	Captain William Moore/Skagway	Alaska	83 (271)	1975
30	Milwaukee Art Museum/Calatrava Bridge ^a	Wisconsin	70 (231)	2003
31	Menomonee Falls ^a	Wisconsin	66 (217)	1971
32	Sixth Street Viaduct—North	Wisconsin	59 (195)	2003
33	Sixth Street Viaduct—South	Wisconsin	59 (195)	2003
34	Sacramento River (Meridian) ^b	California	55 (180)	1977
35	Rockefeller University Campus ^a	New York	38 (123)	1999
36	Old Plank Road Trail Bridge ^a	Illinois	35 (114)	1999
Canada				
1	Alex Fraser (Annacis) Bridge	British Columbia	465 (1,526)	1986
2	ALRT Fraser River Bridge	British Columbia	340 (1,115)	1988
3	Papineau–Leblanc	Quebec	241 (790)	1969
4	Hawkshaw	New Brunswick	218 (713)	1967
5	Longs Creek #1	New Brunswick	218 (713)	1966
6	Price	Quebec	137 (450)	1972
7	Esplanade Riel, Manitoba	Winnipeg	106 (348)	2003
8	Bridge of the Isles	Quebec	105 (344)	1967
9	Stoney Trail ^a	Alberta/Calgary	102 (335)	1998
10	Galipeault	Quebec	94 (308)	1963
11	Carburn Park ^a	Alberta/Calgary	80 (262)	1982
12	Prince’s Island ^a	Alberta/Calgary	67 (220)	1972
13	Nackawic River	New Brunswick	66 (216)	1967
14	North Romaine River ^c	Quebec	61 (200)	1960
15	McMahon***	Alberta/Calgary	47 (154)	1987
16	Fox Hollow***	Alberta/Calgary	45 (148)	1996

Notes: Bridges are cited in order of span length, from longest to shortest. After the completion of this report, three additional, recently built pedestrian cable-stayed bridges were identified in the United States; two in downtown Denver, Colorado, and one in Redding, California. These three bridges are not included in the analysis.

^aPedestrian.

^bSwing movable bridge.

^cRailroad bridge.

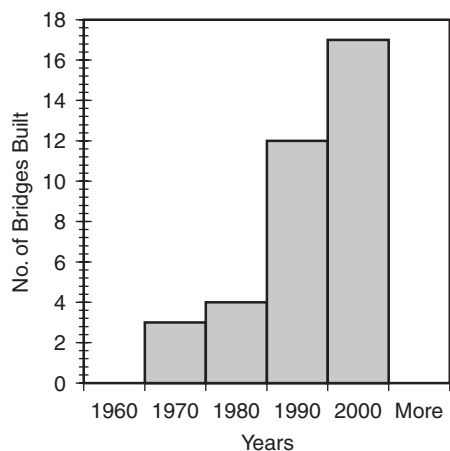

FIGURE 3 Number of cable-stayed bridges built in the United States.

similar to the suspension bridge main cables. The Papineau Bridge in Montreal (1969) incorporated galvanized bridge strands covered with polyethylene (PE) sheathing. The Sitka Harbor Bridge in Alaska (1970) also used galvanized bridge strands as cables, but without the PE sheathing. The Pasco–Kennewick (or Gum Street–Kennewick) Bridge in Washington State (1978) was the first cable-stayed bridge in the United States to use parallel nongalvanized (bare) wires encased in high-density polyethylene (HDPE) pipe wrapped with polyvinyl chloride (PVC) tape and grouted with cement grout. This was a fundamental shift from the earlier designs based on the industrial and suspension cable technologies involving galvanized wires and strands toward grouted cables based on the post-tensioning technology. As will be discussed later, this grouted cable approach was first implemented in Europe, most notably on the Brotonne Bridge in France, before its implementation on the Pasco–Kennewick Bridge. This approach of using HDPE pipes filled with cement grout began the “grout era” in the United States, which dominated the U.S. stay cable designs for nearly two decades until the late 1990s. The Canadians, the Germans, and the Japanese among others have primarily

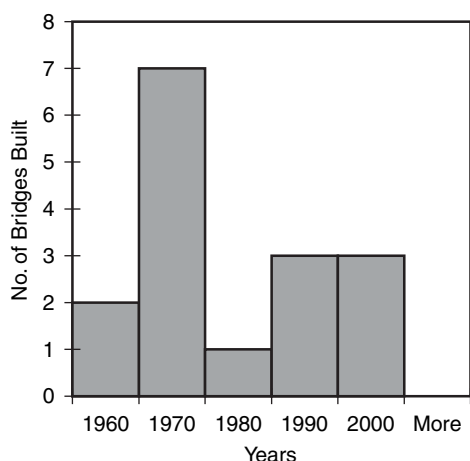

FIGURE 4 Number of cable-stayed bridges built in Canada.

avoided the grouted cable approach. The Pasco–Kennewick Bridge was also the first of its kind in the United States to use a larger number of cables (i.e., reduce cable spacing).

In Canada, the 465-m Alex Fraser Bridge (1986) included long-lay galvanized bridge strands that were jacketed with PE filled with petroleum wax blocking compound. The first and only cable-stayed bridge in the United States that uses steel bars (or threadbars) is the Dame Point Bridge in Jacksonville, Florida (1989). In that bridge, the nongalvanized bars are encased in steel pipe and grouted. There are four pedestrian bridges in Calgary, Canada, that use bar stay cables, all galvanized without HDPE or grouting. The bars are anchored through threaded couplers. The first stay cables with epoxy-coated seven-wire strands were installed on the Quincy/Bayview Bridge in Quincy, Illinois (1986).

In the last 20 years, the design of stay cables including the corrosion/fatigue protection systems have significantly and continuously evolved and been modified. In the 1990s, systems offered by all of the major stay cable suppliers were rarely (if ever) left unchanged between consecutive projects despite economic incentives to limit such changes. This was primarily because the designers, cable suppliers, and owners learned from their experiences and the performances of the earlier stay cable systems during qualification testing and construction.

Since 2000, a tentative convergence of approaches emerged among some of the stay cable systems offered by various suppliers in the United States. All major U.S. stay cable suppliers began offering at least one system involving parallel seven-wire strands that were individually greased-and-sheathed (or waxed-and-sheathed), encased in an ungrouted HDPE pipe, and anchored with wedges. Individual stressing of strands, as opposed to simultaneous stressing of all strands with large hydraulic jacks, was commonly used. Some of the more recent systems reportedly allow periodic removal of individual strands for inspection and sometimes provide room for future additions of strands into the cables.

Following this introductory chapter, chapter two provides an overview of various stay cable systems, touching on design, materials, fabrication, and erection. Chapter three describes short- and long-term inspection and monitoring techniques. Chapter four discusses the maintenance and repair of stay cables, chapter five briefly discusses future trends, and chapter six summarizes the findings and provides suggestions for future research.

The survey questionnaire is included as Appendix A. Appendix B provides detailed statistical tabular summaries of the answers to each of the multiple-choice questions as provided by the respondents for all bridges. The answers are categorized as U.S. responses, Canadian responses, and all responses. Appendix C is a web-only section of the report that provides detailed question-by-question results of each bridge surveyed and comparative tables of the the different responses to each question. This appendix can be found at: http://trb.org/publications/nchrp/nchrp_syn_353.pdf.

STAY CABLE SYSTEMS AND MATERIALS

STAY CABLE SYSTEMS

An overview of various stay cable systems is presented in this section to familiarize readers with the terminology and technical aspects of various cable designs, and the issues related to inspection and maintenance of stay cables in cable-stayed bridges. In very general terms, a stay cable can be described as a tension element composed of a single or multiple longitudinal MTEs, which is connected at one end to the bridge pylon and anchored at the other end at the bridge deck.

Over the years, there have been two fundamentally different and competing philosophies regarding design of stay cables. In the first approach, which dominated early German, British, and Japanese designs, the stay cables were designed based on the well-developed suspension bridge technologies; that is, those of the main suspension cables and the hanger cables, and wire rope technology from industrial applications. In the second approach, which more or less began with the Brotonne Bridge in France and dominated the U.S. stay cable designs until late 1990s, the cables were designed based on the post-tensioning tendon technologies. There were also variations in each of the two main philosophies. The concepts underlying these philosophies and their significant evolution over the last 30 to 40 years will be discussed later in this chapter. The motivations for these system evolutions were based on the field performance of the systems, technology developments and, above all, economic factors.

Main Tension-Resisting Elements

There are several different arrangements of the MTE components in the free length of the cable. The free length refers to areas of the cable that are not in the vicinity of the anchorages. The MTE could be a single bar, multiple parallel bars, multi-wire helical strands (wire ropes or bridge strands), a bundle of parallel wires, or a bundle of parallel seven-wire strands. Figure 5 shows some of the MTE systems.

The locked coil cable was very common in early European and Japanese cable-stayed bridges. There is a central core of parallel round wires surrounded by spirally wrapped layers of interlocking z-shaped (and in some cases trapezoidal) wires. This arrangement makes a denser more compact cable (with reduced voids), with a smooth outer surface and less sensitivity to side pressures (Walton 1996; Ito 1999). Helical wire

ropes have been popular in the United Kingdom. The spiral wires reduce the modulus of elasticity and strength of cable compared with equivalent parallel wire cables, but are much easier to handle (Ito 1999). The locked coil cable and spiral strands are examples of applications of suspension cable technology to stay cables.

The single or multiple bar system typically consists of one or more thread bars with a diameter of 26 to 36 mm (1–1.375 in.). The Dame Point Bridge in Florida and four pedestrian bridges in Calgary include bar cables. Worldwide it is believed that three other cable-stayed bridges with bars have been built; one each in Malaysia, Germany, and Chile. The parallel wire cables are typically made of 5 to 7 mm (0.19–0.27 in.) wires. Unlike the main suspension cables, the parallel wire stay cables do not include closely wrapped external spiral wires to maintain the shape of cable. The Pasco–Kennewick Bridge in Washington State and the Hale Boggs/Luling Bridge in Louisiana are examples of parallel wire cables in the United States.

The parallel seven-wire strand system is the most common MTE used in the United States. The survey results indicated that 75% of U.S. bridges included parallel seven-wire strands (see Figure 6). In contrast, only one bridge in the Canadian survey had seven-wire strands. The only Canadian bridge with parallel strands is also the newest one (opened to traffic in 2003), pointing to a possible move toward parallel strands. The majority of the Canadian bridges surveyed (54%) have steel wires. There are however four bridges with parallel bars in Canada. The guaranteed ultimate tensile strength of seven-wire strands is 1860 MPa (270 ksi).

The wire and strand stays are continuous from anchorage to anchorage because they are produced in long lengths and transported on reels, but bar systems require splicing with couplers, because the maximum length of individual bars is on the order of 18 m (60 ft). Figure 7 shows a bar cable with couplers.

The factors that typically drive the decision on the choice of MTEs have generally included the geographic preferences of the designers, suppliers, and owners (based on adopted design philosophies and available materials), perceived notions of long-term durability (i.e., potential for corrosion and fatigue), and cost. More recently however, issues related to inspectability, feasibility for nondestructive evaluation (NDE), and possibilities for MTE replacements and additions have also entered

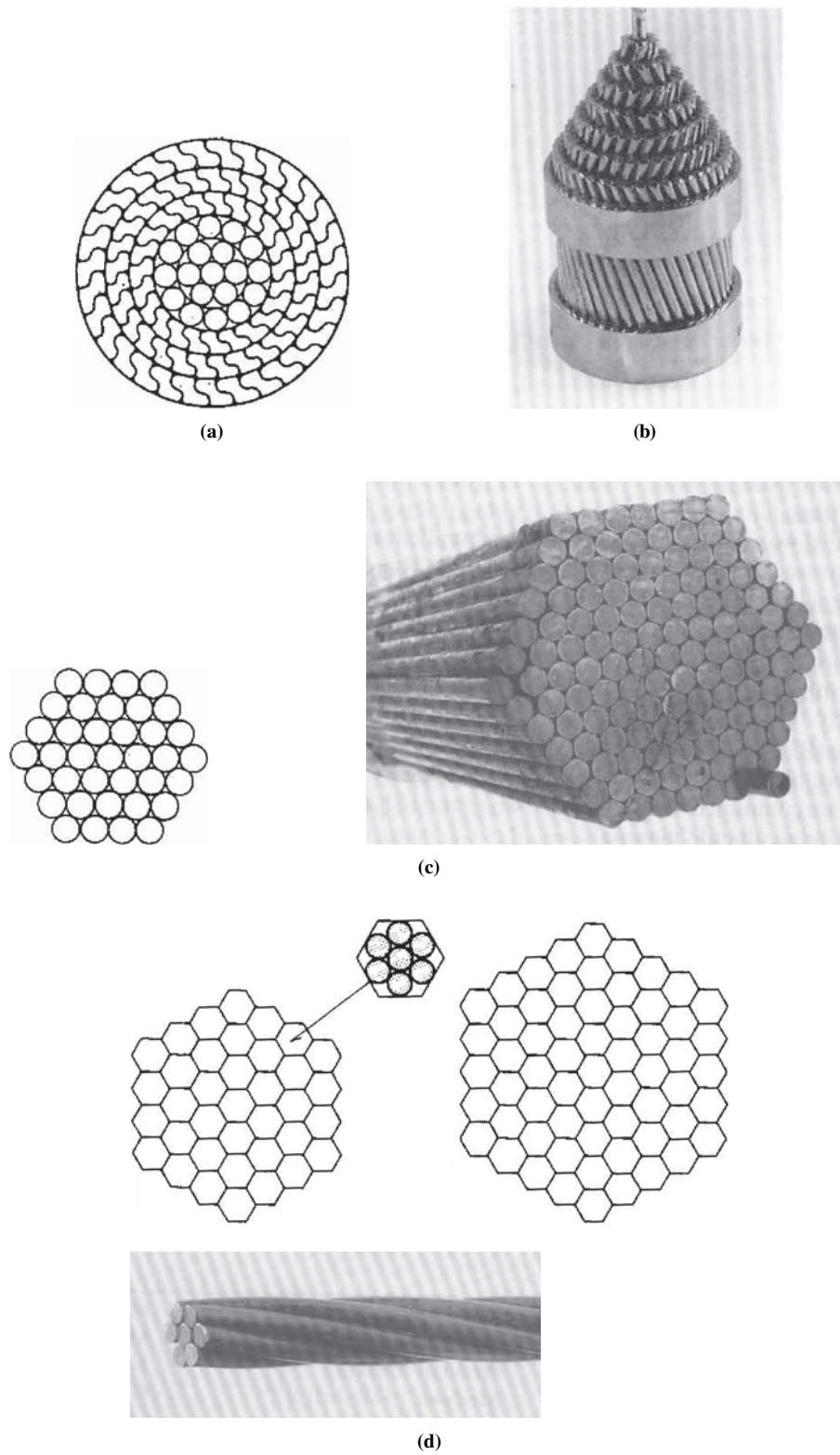

FIGURE 5 Various MTE cross sections: (a) locked coil, (b) helical strand, (c) parallel wire, (d) parallel seven-wire strands (Gimsing 1998).

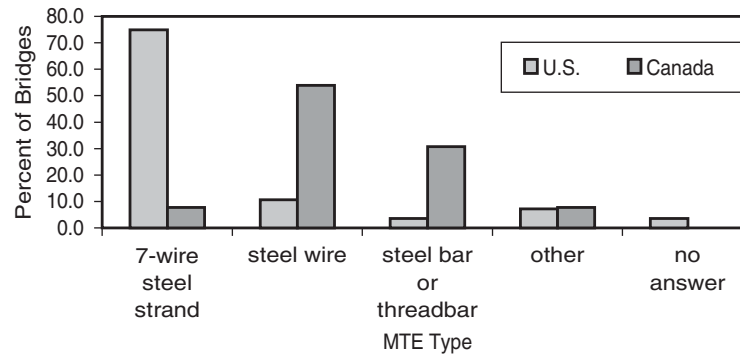

FIGURE 6 Types and frequency of main tension elements used.

the decision process. The arguments that are generally made for, or against, one MTE system or another involve some of the factors listed here:

- Cost,
- Implications of corrosion exposure including surface-to-volume ratio,
- Fatigue performance including implications of crack propagation,
- Redundancy,
- Interwire fretting,
- Notching at anchorages,
- Stiffness,
- Tightness of MTE bundle (void areas),
- Implications of vibrations,
- Ability to adjust MTE force, and
- Ability to remove and augment MTE.

Anchorage Systems

There is a great variety of anchorage systems used for stay cables, depending on the choice of the MTE and the cable

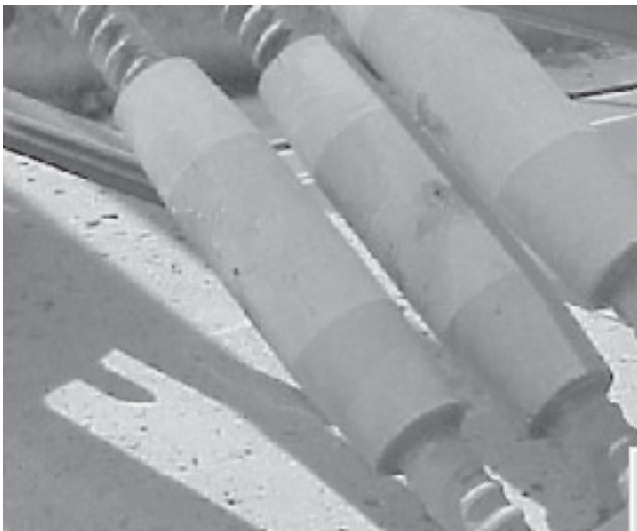

FIGURE 7 Typical bar couplers in stay cables.

manufacturer. In bar systems, threaded nuts (matching the large threads on the bars) and anchor plates are used for anchorage. In this section, a brief discussion of generic categories of cable anchorages for parallel wires and strand cables is presented. For the sake of brevity, only anchorage systems common to the United States are discussed. However, such systems are commonly used worldwide. In the cable free length, the parallel wires or strands are bundled together, thus making contact with each other. As the cable approaches an anchorage, the wires or strands must separate from each other to achieve proper anchorage. The distance from the point that the strands (or wires) splay out to the anchorage point is generally referred to as the anchorage length.

There are three fundamental approaches to cable anchorage design. The first is to individually anchor each splayed wire or strand at a single point on an anchorage plate. That anchorage point would exclusively carry all dead and live loads imposed. The second is to transfer all loads through a conical steel socket. The force in the MTE transfers by bond through a filler material inside the conical socket. The third is a combination of the first two approaches; that is, transfer dead loads through the anchorage point and carry live loads through the socket action.

Point Anchorages

Figure 8 shows the point anchorage concept. Typically, a two- or three-piece conical wedge with a toothed center hole grabs on the outside of the seven-wire strand and anchors it. This is essentially a modified version of the wedge system used in post-tensioning applications. Examples of this type of anchorage include the Charles River Bridge in Boston and the C&D Canal Bridge in St. Georges, Delaware. When individual wires are used, they are generally terminated at a “button head” that is formed at the ends.

In the multistrand system with point anchorages, the cable can be assembled in the field by stressing all strands at the same time, or it can be stressed one strand at a time (using a system to ensure equal distribution of stress). The gripping wedges create notches on the strands, which could become fatigue initiation points. However, stay cable systems

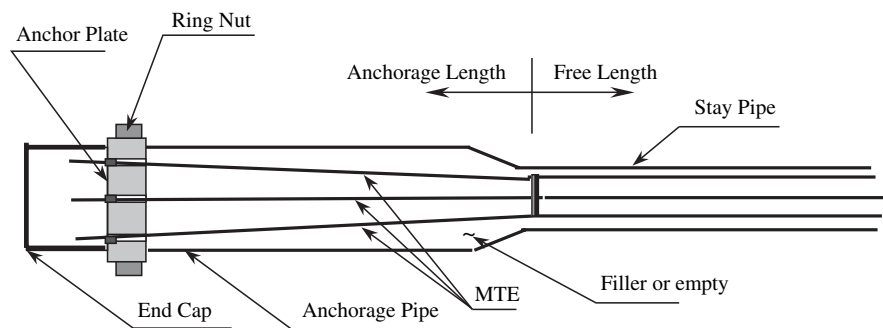

FIGURE 8 Point (wedge) anchorage concept.

go through fatigue qualification tests that they must meet. The other consideration regarding point anchorage systems is the performance of such systems in a rapidly detensioning cable during an earthquake. The concern is that in such a case the wedges could potentially exit the anchorage plate, resulting in the loss of anchorage. There have not been however any reported cases of such an occurrence, and there is no information available regarding cable performance in such scenarios.

“Hi-Am”-Type Anchorages

Figure 9 shows a “Hi-Am”-type socket. The strands or wires splay out at the entrance to a steel socket that is cylindrical on the outside and conical on the inside. The socket is typically filled with epoxy and small steel balls as well as zinc dust. The MTEs terminate at a locking plate. An example of this type of design is the Luling Bridge in Louisiana.

This type of anchorage has to be assembled to the right length at a plant and brought to the site, usually on reels. The load transfer between MTE and socket occurs over the length of the socket and not at a single point. The cable must be stressed as a whole.

Bond Socket-Type Anchorages

Figure 10 shows a bond socket anchorage. In this type of anchorage the strands are terminated at an anchorage plate with wedges, but there also exists a conical pipe (conical outside and inside) that is filled with either cement grout or epoxy compound. Examples of this type of anchorage include the

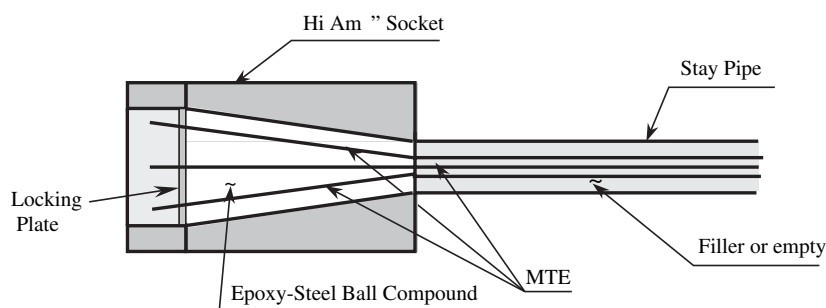

FIGURE 9 “Hi-Am” type anchorage.

Clark Bridge in Illinois (with grout-filled socket) and the Cochrane Bridge in Alabama (with epoxy-filled socket). When cement grout is used, the wedges carry the initial stresses on the cable before grouting (or epoxy filling) operations are completed (similar to point anchorage). Following grouting, the socket would be expected to resist changes in cable load. Therefore, the intent of this system is to minimize stress changes at the point anchorages. This type of anchorage can be assembled in the field if the grout or epoxy compound is injected after the initial installation of strands and stressing.

Figure 11 shows the results of the survey as related to the types of anchorage systems. In the United States, the conical socket with wedges and the point (wedge) system were dominant. It is clear however that the respondents did not similarly understand the anchorage characterizations, and some misidentifications may have occurred.

Recent Trends in Anchorage Design

In recent years, the differences between the approaches to anchorage design of various cable manufacturers’ have narrowed to some extent. Currently (in 2005), all of the major stay cable manufacturers in the United States have at least one system that more or less falls within the point anchorage system described in Figure 8.

Shop or Field Cable Fabrications

There are two different approaches regarding the assembly and erection of stay cables. In one approach, the stay cables

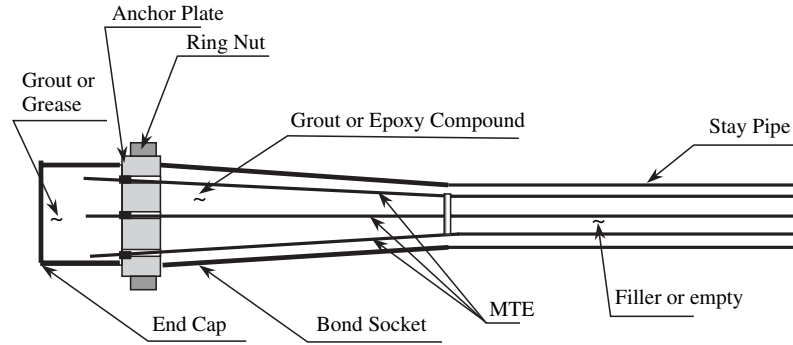

FIGURE 10 Bond socket anchorage system.

are shop-fabricated and installed in the field as a unit. This is typical of the Hi-Am-type anchorages. However, field fabrications have become more common in the United States, especially in the last decade. For field assembly, the cable sheathings are first welded together on the bridge and lifted into place (Figure 12a). Then, strands are typically individually inserted into the anchor plates at the bottom anchorage and fed through the stay pipes towards the top anchor plate (Figure 12b).

The strands can be collectively stressed with large hydraulic jacks or, as is more commonly done today, they are individually stressed with small jacks as they are inserted in the cable. Different cable suppliers have their own procedures and methods to achieve equal force in all strands. Shop fabrications are still very common in Japan. The Alex Fraser (Annacis) Bridge in British Columbia has shop-fabricated cables (Saul and Svensson 1991). The Burlington Bridge in Iowa and the Luling Bridge in Louisiana are examples of shop-fabricated cables in the United States.

Saddles

The costliest components of a stay cable are the anchorages. Therefore, some designers elect to eliminate anchorages at the pylon by providing a continuous cable through the pylon. The curved saddle at the pylon is typically a steel pipe that redirects the cable force through the pylon. Another reason

given is that the pylon can be smaller (narrower) when there are no anchorages (Figure 13). However, large transverse forces are generated on the cable and individual strands in the saddles, especially at the entrances to the pylon. As the strands enter the saddle, they begin to move to the bottom of the pipe and large interstrand forces can develop, particularly when bare strands are used. Changes in cable tension can result in fretting and fatigue. Such fatigue fractures have been observed on at least one qualification test of a saddle system (Tabatabai et al. 1995). In that test, bare strands were used and fractures were initiated at oval-shaped fretting marks at interstrand contact points.

To address these issues and reduce interstrand contact, coated strands (such as epoxy-coated) have sometimes been used. In the case of the Maumee River Bridge in Ohio, the engineer designed a “cradle” system in which each strand passes through its own stainless steel sleeve within the cradle assembly (Harris 2002).

An FHWA Technical Advisory released in 1994 (“Cable Stays . . .” 1994) discussed a number of factors related to saddles and discouraged the use of saddles at that time. However, the use of saddles has continued in the United States. Among the factors cited by the FHWA advisory were:

- Stressing of cables with saddles requires simultaneous stressing from both anchorages (during and after construction);

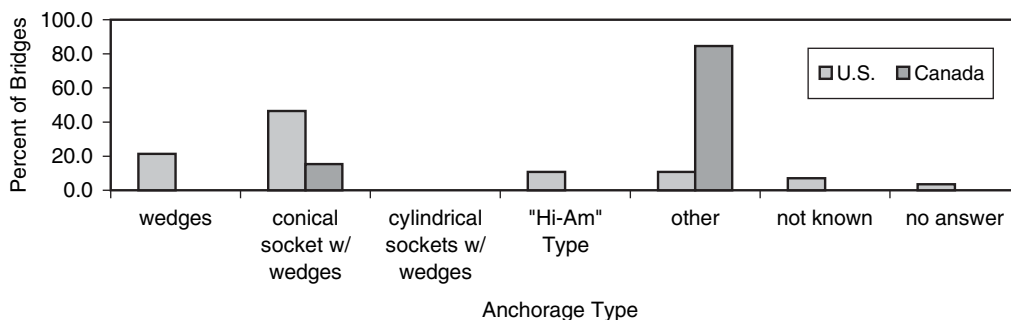

FIGURE 11 Type and frequency of anchorage used.



(a)



(b)

FIGURE 12 Field assembly of cables for the Cape Girardeau Bridge (courtesy: Missouri DOT).

- A more difficult cable removal and replacement process would be required should that become necessary;
- Precluding slip at the saddles would require special considerations;
- In large single saddles, the application of protective tape may become difficult in the vicinity of large single saddles as spaces between cables are reduced;
- Steel pipe at large single saddles should not participate in load transfer to the pylon (i.e., tension in the steel pipe controlled); and
- Geometric control through cable length would be more difficult.

In 1993, a worldwide survey of stay cable practitioners by Hamilton and Breen (1995) indicated that the majority of respondents did not favor the use of saddles, with European respondents having the highest rate of objections at 76%. The results of the questionnaire in this study showed a total of seven bridges with saddles (21%), six of which were in the United States and one in Canada (Figure 14).

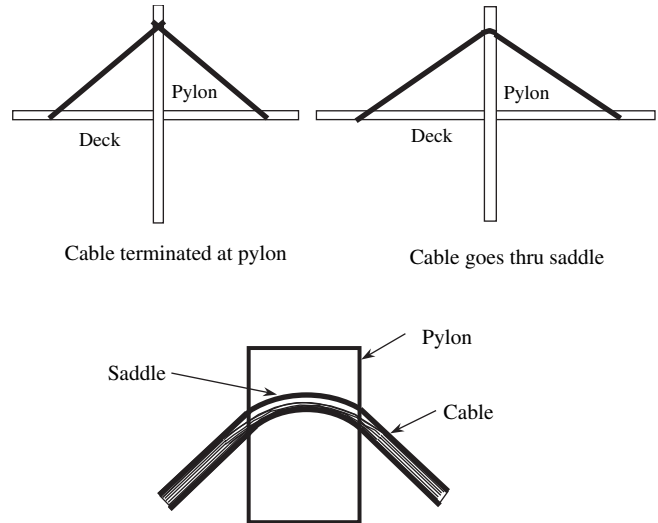

FIGURE 13 Saddles in stay cables.

STAY CABLE MATERIALS

In this section, the materials used in cable systems are discussed, and the importance of detailing and issues of material suitability and compatibility are presented.

MTE Materials

Steel

Today, steel is the predominant MTE material used for stay cables (100% of cable-stayed bridges in the United States and Canada). According to the latest edition of the PTI *Recommendations for Stay Cable Design, Testing and Installation* (2001), steel wires used as MTEs must conform to the requirements of ASTM A421/A421M, Standard Specification for Uncoated Stress-Relieved Steel Wire for Prestressed Concrete, Type BA. Strands must conform to ASTM A416/A416M, Standard Specification for Steel Strand, Uncoated Seven-Wire for Prestressed Concrete, and must be weldless, low-relaxation grade. Bars must conform to ASTM A722/A722M, Standard Specification for Uncoated High-Strength Steel Bar for Prestressing Concrete.

Fiber-Reinforced Polymers

In recent years, a number of exploratory efforts have focused on the use of fiber-reinforced polymers (FRPs) in prestressing applications and stay cables. These investigations have generally focused on glass, aramid, or carbon fiber-reinforced polymers (GFRP, AFRP, and CFRP). Epoxy-based resins are typically used as the matrix for the composite, and the FRP is made using a pultrusion process. Fisher and Bassett (1997), Christoffersen et al. (1999), Roos and Noisternig (1999), and Noro et al. (2001) provided information on the properties of FRP composites and their comparison to steel.

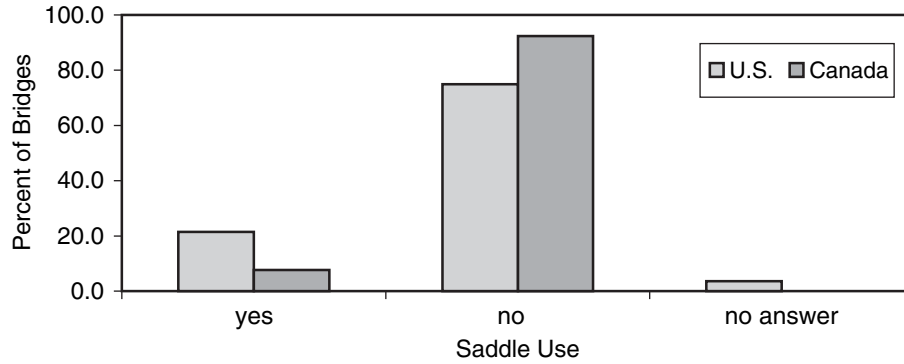

FIGURE 14 Use of saddles.

Tables 3 and 4 show reported comparisons of different material properties.

The main advantages of FRP composite cables are corrosion resistance and lighter weight. For CFRP, the coefficient of thermal expansion is much lower than steel (approximately one-sixtieth), and the strain at rupture is reported to be 1.6% as compared with 6% for steel (Roos and Noisternig 1999). The main disadvantages of FRP composites are their high cost and very low shear strength (both transverse and interlaminar shear strengths). The low shear strength seriously affects the gripping ability at anchorages (Christoffersen et al. 1999). Fisher and Bassett (1997) reported that although composite materials do not rust, “they can corrode when integrated into structures with incompatible materials.” They report that carbon fiber can be subjected to galvanic corrosion with metals and thus should be insulated from metallic anchorage components. Similarly, glass fiber prestressing tendons “can be susceptible to corrosion under sustained loads when exposed to water or salt water.”

Various manufacturers have devised anchorage solutions. These solutions, an example of which is shown in Figure 15, are typically based on a conical steel socket filled with a potting material such as epoxy. However, a wedge-type anchorage system for the carbon fiber composite cables of a pedestrian bridge (the Laroin Bridge in southern France) has been devel-

oped. There is a cushioning layer used between the jaws and the rods (*Bridge Design and Engineering* 2005).

A number of demonstration projects have been built with FRPs. However, there are currently no known cable-stayed bridges in the United States and Canada with FRP cables. According to Seible and Burgueno (1997), the first all-composite cable-stayed pedestrian bridge was built in Aberfeldy, Scotland, in 1993, with aramid fiber stay cables. These authors also reported on the design of a vehicular cable-stayed composite bridge on the campus of the University of California, San Diego (I5/Gilman). However, this bridge has not been constructed.

Christoffersen et al. (1999) reported on the construction of a CFRP cable-stayed bridge in Denmark. To protect against possible damage to cables from fire, impact, or vandalism (saw cutting), the designers used stainless steel sheathing over an extruded HDPE sheath. The design was also based on the ability to sustain static failures of two adjacent cables or a sudden failure of one cable. Provisions were made for periodic replacement of an original cable at 5-year intervals.

The Storchenbrücke (Stork) Bridge in Winterthur, Switzerland, incorporates two CFRP stay cables, each consisting of 241 parallel pultruded CFRP rods of 5 to 6 mm in diameter (Hooks et al. 1997). The other 22 stay cables on this bridge

TABLE 3
TYPICAL PROPERTIES OF THE MOST COMMON FRP MATERIALS AND STEEL

Material	Tensile Strength ksi (MPa)	Young’s Modulus ksi (GPa)	Density lb/ft ³ (kg/m ³)
CFRP (carbon)	245–435 (1700–3000)	20300–43500 (140–300)	100 (1600)
AFRP (aramid)	175–305 (1200–2100)	7250–17400 (50–120)	81 (1300)
GFRP (glass)	218 (1500)	7250 (50)	150 (2400)
Steel	270 (1860)	29000 (200)	490 (7850)

Source: Christoffersen et al. (1999).

TABLE 4
QUALITATIVE COMPARISON OF FRP PROPERTIES

Properties	GFRP	AFRP	CFRP
Environmental resistance	—	+	+
Tensile strength	+	+	++
Fatigue strength	0	—	++
Young's modulus	—	—	++
Creep/relaxation	—	0	++
Stress fatigue	—	—	++
Density	+	++	++
Material price	++	—	—

Notes: — = not good, 0 = neutral, + = good, ++ = very good.
Source: Christoffersen et al. (1999).

have steel MTEs. The stiffness of the anchorage filler material was varied along the length of the anchorage by adding aluminum oxide pellets with varying thicknesses of epoxy coating. The cables passed qualification fatigue and static testing (Hooks et al. 1997).

Roos and Noisternig (1999) reported on fatigue and static testing of CFRP stay cables with up to 91 wires using PTI recommendations. The cable sustained two million cycles of fatigue loading without wire failure, but reached only a maximum of 78% of nominal capacity and thus did not meet the requirements.

MTE Coatings

Various MTE coatings are available worldwide. These coatings are mainly provided for the corrosion protection of MTE. In earlier stay cable designs when uncoated strands and cement grouts were used, it was assumed that grout would provide the necessary protection. However, given that the time between stressing of strands and grouting could be several months or years, it soon became clear that the strands would be left unprotected and could corrode within that time period. One of the early steps taken to address this issue was to use water-soluble oil sprays on the strands (Funahashi 1995). Later, a protective/lubricant coating (a petroleum microcrystalline wax based product) was applied to the strands.

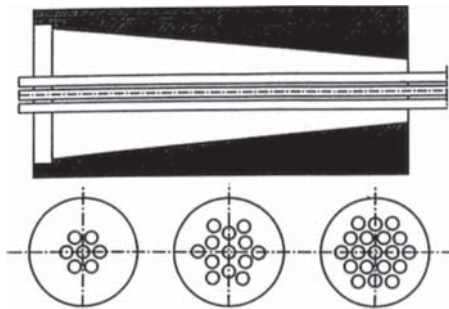

FIGURE 15 One type of CFRP anchorage (Roos and Noisternig 1999).

Figure 16 shows the results of the survey with respect to the type of MTE coatings used, if any, on bridges in the United States and Canada. Strands and wires that are coated with temporary protection oils, as described previously, are considered bare in the survey. Cables with bare MTEs represent 43% of the survey bridges in the United States, whereas no Canadian bridges use bare MTEs.

Galvanizing

A very common coating for strands that is used extensively in Europe and Japan is zinc coating (hot dip galvanizing). Galvanizing is a sacrificial form of cathodic protection against corrosion and can be consumed with time, especially in an aggressive environment. In the United States, however, galvanized MTEs have not been used very often for stay cables, except for the Sacramento River (Meridian) Bridge in California and the two early bridges in Alaska, including the oldest cable-stayed bridge in the United States, the Sitka Harbor Bridge. The main concern has been that the galvanizing process, especially with strands in contact with grout, could lead to hydrogen embrittlement. Corrosion and other electrochemical processes can lead to evolution of hydrogen. Absorbed hydrogen can reduce the ductility of steel, through a phenomenon known as hydrogen embrittlement (Barton et al. 2000). On the other hand, 61% of Canadian bridges in the survey used galvanized MTE members. However, none of the Canadian bridges included galvanized MTE in contact with cement grout.

It was also believed that the process of galvanizing would degrade the tensile strength of strand and its fatigue life ("Cable Stays . . ." 1994). The concern for contact between galvanized strand and cement is widely held (Ito 1999). However, PTI recommendations state that "galvanized prestressing strand may be used in contact with cement grout provided the steel has been manufactured in accordance with the latest ASTM A416, BS 5896, or EN 10138 standard. Experience has shown that strand manufactured to these standards is not susceptible to hydrogen embrittlement" (*Recommendations for Stay Cable Design . . .* 2001). The PTI document does not refer to other references that form the basis for that statement.

The PTI recommendations also include the following:

Galvanized strand is made from either as-galvanized wires (in Japan) or drawn-galvanized wires (in Europe). The advantage of as-galvanized wire is heavier coating weight (300 g/m²) or more for better corrosion protection. The advantage of drawn-galvanized wire, on the other hand, is improved fatigue performance and tighter control on tolerance.

In Europe, galvanized wires and strands are routinely used for ungrouted stay cables, and special manufacturing processes are adopted that reportedly ensure compliance with the strength and fatigue requirements including those of the standards listed by the PTI document. In the United States, the market

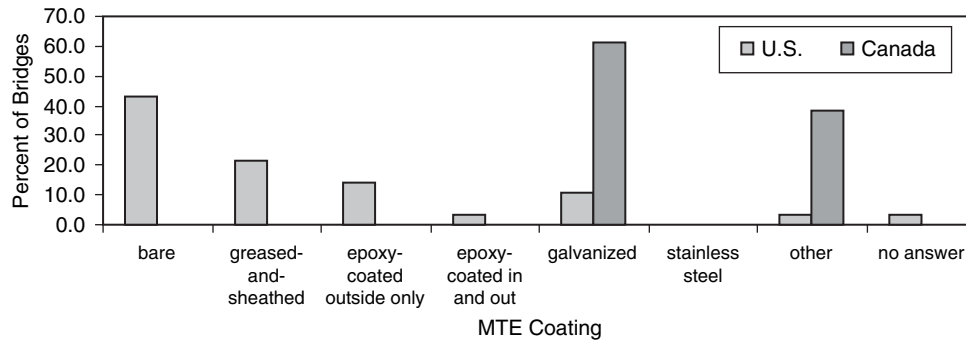

FIGURE 16 Types of MTE coatings used.

conditions have reportedly not yet justified local production of galvanized strands of sufficient quality (fatigue and strength) for use in stay cables. The Buy America Act enacted by the U.S. Congress in 1933 has so far effectively prevented the importation of stay cable-quality galvanized strands. According to the Buy America Act, all federal construction contracts that are undertaken within the United States must use domestic construction materials, subject to a few exceptions. Therefore, galvanized wires and strands are currently not being used in U.S. stay cables.

Suzumura and Nakamura (2004) studied environmental factors affecting corrosion of galvanized steel wires for suspension bridges. They concluded that galvanized steel wires did not corrode when kept in an environment with a relative humidity of less than 60%. The corrosion rate increased significantly with temperature. They reported that for a wire kept in a wet environment the zinc layer (350 g/m²) would be consumed within 10 years. In 100% and 60% relative humidity environments, the consumption of zinc would be complete in 34 years and 211 years, respectively. Figure 17 shows the effects of relative humidity and sodium chloride on the corrosion rate. Figure 18 shows the effect of temperature on the corrosion rate.

Tarui et al. (2001) reported that galvanized wires with strengths of 256 ksi (1770 MPa) for 7 mm/0.276 in. wires and

284 ksi (1960 MPa) for 5 mm/0.197 in. wires have been developed in Japan. They reported good fatigue and low-temperature response and elongations of 6% to 7%. Tauri et al. (2001) attributed the loss of strength in galvanized wires to the “spheroidizing of cementite, resulting in the collapse of the lamellar structure of ferrite and cementite.” They reported that the silicon and chromium elements can suppress this loss of strength.

It should be noted that galvanized strands individually sheathed with HDPE are also available and have been used overseas. According to a worldwide survey of the stay cable industry performed by Hamilton and Breen (1995), the galvanized-and-sheathed strand is the most highly rated by the respondents.

Individually Sheathed Strands with Corrosion Inhibiting Coating

PTI provides detailed recommendations for such strands, which are typically referred to as greased-and-sheathed or waxed-and-sheathed strands (*Recommendation for Stay Cable Design* . . . 2001). The grease or wax is believed to reduce potential for fretting fatigue resulting from interwire contact (Frank and Breen 2004). These strands are individually coated and then covered with HDPE or high-density polypropylene

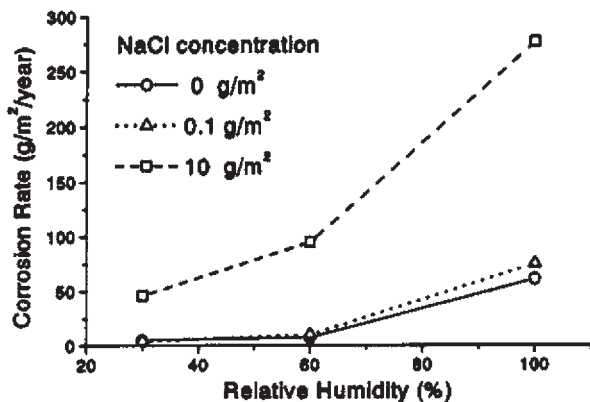

FIGURE 17 Corrosion rate for galvanized wire (Suzumura and Nakamura 2004).

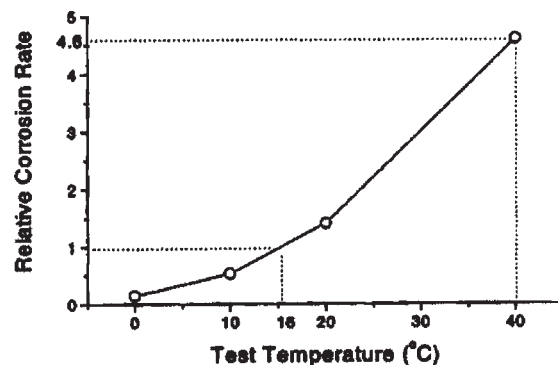

FIGURE 18 Relative corrosion rate—wet condition without chloride exposure (Suzumura and Nakamura 2004).

(HDPP) that is extruded over the strand. These systems have been common in all recently constructed cable-stayed bridges in the United States. Examples of bridges using these types of strands are the Cape Girardeau Bridge in Missouri and the Sixth Street Viaduct Bridges in Wisconsin.

Epoxy Coating

The use of epoxy-coated strands became popular in the United States in the early to mid-1990s, and was used on at least four bridges in the United States in that decade. Three types of such strands were originally available for stay cables. In one, an epoxy coating with a smooth surface was applied on the outside perimeter of the seven-wire strands, thus leaving air voids in the interstitial spaces between the six outside wires and the center wire (Figure 19). The second type of epoxy-coated strand produced was similar to the first, except for a grit-impregnated surface to improve bond with grout. The third type of strand had epoxy in all interstitial spaces in addition to the outside surface. The FHWA advisory (“Cable Stays . . .” 1994) and the current PTI provisions (*Recommendation for Stay Cable Design* . . . 2001) recommend that only epoxy-coated strands with filled interstices should be used for stay cables.

Qualification tests in the early 1990s on unfilled strands indicated that pressurized grout water could infiltrate the void spaces inside the strands and remain there as free water, resulting in extensive corrosion and fatigue fractures in the time period of the test (Tabatabai et al. 1995). Although a complete determination of the path of water was not made, it was clear that one likely source was the penetration (and breach) of the epoxy coating at the wedges. Corrosion tests by Hamilton et al. (1998b) also showed corrosion inside unfilled epoxy-coated strands, but no corrosion was found in the filled strands.

Saul and Svensson (1991) reported that during the installation of stay cables for the Quincy Bridge in Illinois, “it became apparent that the ends of the strands must be sealed with an epoxy coating in order to prevent moisture rising due to capillary pressure through the full height of the cables in the interstices between the individual seven wires forming each

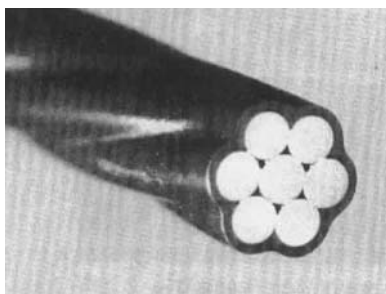

FIGURE 19 Epoxy-coated strand (Funahashi 1995).

strand.” According to the questionnaire response received, moisture has been found in the cable anchorages on this bridge.

Cable Sheathings and Wraps

Options for cable sheathings include HDPE, steel, stainless steel, or aluminum (Ito 1999). The most common cable sheathing is HDPE (Figure 20). Seventeen U.S. cable-stayed bridges included in the survey responses (61%) have HDPE pipes around the cables. However, other bridges such as the Dame Point Bridge (Florida), Maumee River Bridge (Ohio), and the Sunshine Skyway Bridge (Florida) have steel pipes. The new Maumee River Bridge is designed with stainless steel pipes. The cable sheathing, when used, serves as the first line of defense, a barrier against damage or intrusion of harmful substances from the outside. In cases where grout or other fillers are used, the sheathing also serves as a container for the filler. The survey indicates that three bridges in the United States and nine bridges in Canada do not have any external sheathing.

The HDPE pipes include approximately 2% to 3% carbon to protect against ultraviolet radiation (Saul and Svensson 1991; Ito 1999). However, considering that the coefficient of thermal expansion of HDPE is much higher than the grout or steel (Funahashi 1995), and that the basic color of HDPE with carbon is black, the issue of increased surface temperatures had to be addressed. Saul and Svensson (1991) reported that the surface temperature of black pipes can reach more than 149°F (65°C) owing to direction solar radiation, whereas the surface of a white pipe under the same condition would reach only 104°F (40°C). Paint does not adhere well to HDPE. Until recently, new HDPE-covered cables were commonly wrapped with a light color self-adhesive polyvinyl fluoride (PVF) tape (mostly referred to by the commercial name Tedlar®), which was spirally wrapped around the HDPE pipe. Typically, a 50% overlap is provided.

Some damage has been reported on wrapped tapes in some bridges (based on the survey results). In one case, the Pasco-Kennewick Bridge in Washington State, the damage was reported to be extensive. In that case, polyvinyl chloride (PVC) tapes were first used over the pipes, and these tapes became brittle after several years and began to flake off (Saul and Svensson 1991). In other cases, the damage was reported to be minor. A laminated tape consisting of a translucent Tedlar tape with a color PVC tape backing was also developed (Saul and Svensson 1991). In recent years, co-extruded HDPE pipes with bright surface colors have entered the market, and recently constructed bridges use this approach in lieu of the PVF tape. Figure 21 shows the results of the survey with respect to damage to the protective tape.

In tests performed by Hamilton et al. (1998), clear HDPE sheathing was used to allow assessment of grout condition inside the sheathing. There is no information available that would indicate if clear HDPE sheathing has ever been used

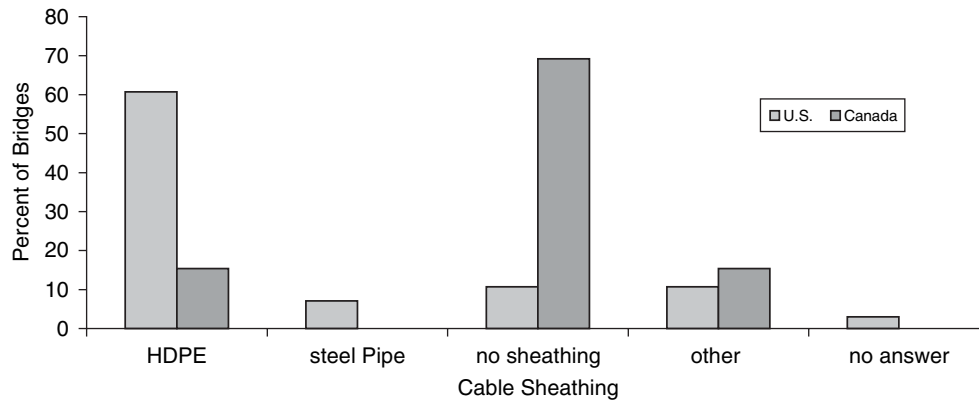

FIGURE 20 Types of cable sheathing used.

on stay cables in the field to facilitate inspections. An important challenge would be the required resistance to ultraviolet radiation.

Figure 22 shows the results of the survey with respect to the cracking of cable sheathing or sheathing connections. Four bridges or 14% of the respondents in the United States (and none in Canada) reported problems with the sheathing or connections. In the C&D Canal Bridge in St. Georges, Delaware, cracking of the steel sheathing was noted on one of the stay cables. This cracking was attributed to the position of a grout vent hole at a high-stress location near a pylon. The respondents to the questionnaire also identified two bridges that had splitting of HDPE [Quincy (Illinois) and Luling (Louisiana)].

In field-fabricated cables, the HDPE pipe segments are typically assembled and welded together (HDPE welding) by special machines on the bridge deck before being lifted into place. In some shop-fabricated cable systems, the cable assemblies (including HDPE) are assembled, coiled, and then shipped on large reels. The coiling and uncoiling of HDPE pipes at low temperatures can lead to cracking (Funahashi 1995). In newer shop-fabricated Japanese cable systems, the HDPE is extruded over the MTE bundle, thus creating a tight fit between the sheathing and MTE.

When a cable with HDPE sheathing is grouted, the pipe must resist grouting pressures. This would increase the required

thickness of the pipe. On some of the early bridge projects, such as the Zarate–Brazo Largo Bridges in Argentina and the Luling Bridge in Louisiana, there have been problems with grouting operation that reportedly contributed to the cracking of the HDPE pipe (Saul and Svensson 1991). The authors discussed HDPE stresses as a result of coiling and uncoiling, effects of grouting pressures, and effects of high temperatures at the time of grouting.

Steel pipe segments are typically welded together in the field. The external pipe is generally bolted to the anchorage pipe. The axial and flexural stiffness of the steel pipe is far greater than that of the HDPE. In a grouted system, sufficient bond between the grout and the steel pipe can be developed, thus transmitting some of the fluctuating cable stresses into the sheathing (owing to strain compatibility). In some qualification tests, steel sheathing connections developed fatigue fractures as a result of this unintended effect (Tabatabai et al. 1995). Saul and Svensson (1991) also reported that “some welded connections have failed in the past” without elaborating. Steel sheathings must also be periodically painted to protect against corrosion.

Fillers and Blocking Compounds

Fillers refer to materials placed inside the sheathing and around the MTE. In United States practice, the most common

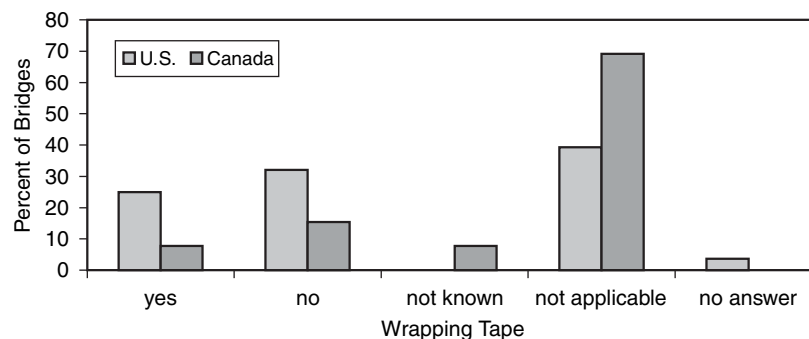

FIGURE 21 Damage to wrapping tape.

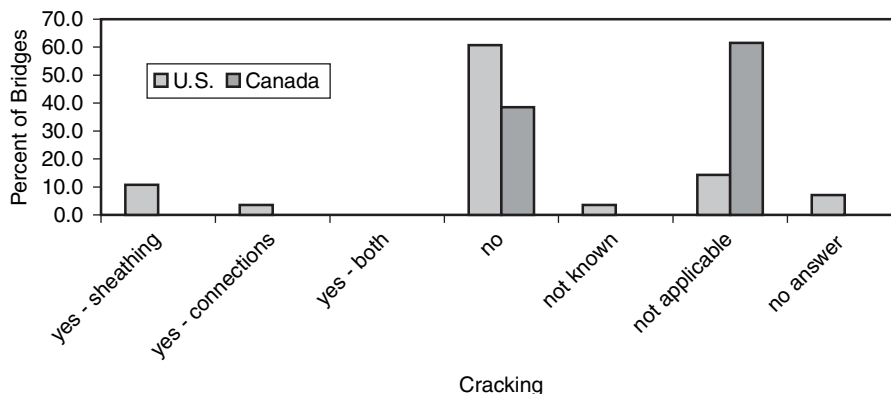

FIGURE 22 Cracking of cable sheathing and connections.

type of filler within the HDPE pipe and the MTE has been the cement grout. Table 5 shows the results of the survey with respect to the type of fillers used, if any, in the stay cables. Fifty-four percent of U.S. bridges in the survey include some type of cement grout in the free length of the cable. None of the Canadian bridges use cement grout. Table 6 shows responses to the survey with respect to the filler materials used in the anchorage zones.

Portland Cement Grout

There have been a variety of opinions on the merits of cement grouts for stay cables. As stated earlier, the practice of grouting stay cables comes from the post-tensioning technology, and not from the suspension cable technology. Grouting has not, in general, been very popular in Europe (Hamilton and Breen 1995). The main advantages typically given for cement grout in stay cables are:

- Cement grout provides a physical barrier for the MTE that is not easily breached.
- Grout provides an alkali environment for the bare steel and protects it against corrosion.

TABLE 5 SURVEY RESULTS—TYPE OF GROUT USED? (Question 4.7)

	U.S.	% U.S.	Canada	% Canada	% total
Grout not used	6	21.4	12	92.3	43.9
Cement-water	5	17.9	0	0.0	12.2
Cement-water-admixtures	9	32.1	0	0.0	22.0
Commercial pre-packaged grouts	1	3.6	0	0.0	2.4
Not known	6	21.4	0	0.0	14.6
Not applicable	0	0.0	1	7.7	2.4
No answer	1	3.6	0	0.0	2.4

- The increased mass owing to the grout helps with damping and vibration control.

The disadvantages are:

- Stress fluctuations in the cable and grout shrinkage can result in the cracking of the grout. This cracking can lead to intrusion of moisture if the external sheathing is breached.
- Grouting adds to the cost of cables.
- Grouting could complicate many types of NDT and inspections.
- Grout water and bleed water could present internally driven corrosion danger when not properly controlled. Voids could be introduced inside grouted ducts.

Tabatabai et al. (1995) performed qualification tests on some grouted stay cable specimens with uncoated (bare) strands. The dissection of cable specimens after fatigue and static tests indicated transverse cracking in the grout. Corrosion was noted on the strand at the intersection of the grout cracks and the strand, some with surface pitting. Fatigue fractures were also noted at those locations, thus establishing that the cracking occurred early in the fatigue test and not in the subsequent static test. Figure 23 shows corrosion at the location of grout cracking. Ito (1999) refers to the presence of grout cracks and how they may be associated with potential for “fretting corrosion” of steel wires.

TABLE 6 SURVEY RESULTS—ARE FILLER MATERIALS USED IN THE ANCHORAGE ZONE? (Question 4.8)

	U.S.	% U.S.	Canada	% Canada	% total
Yes—grout	6	21.4	0	0.0	14.6
Yes—grease	10	35.7	0	0.0	24.4
Yes—other	7	25.0	2	15.4	22.0
No filler	0	0.0	11	84.6	26.8
Not known	4	14.3	0	0.0	9.8
No answer	1	3.6	0	0.0	2.4

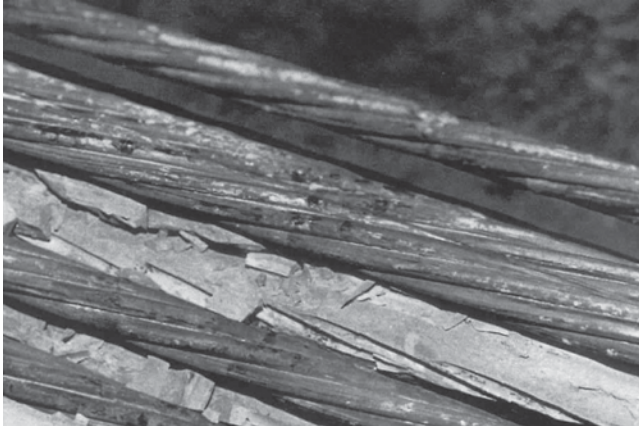

FIGURE 23 Corrosion of strand at transverse crack in grout.

There are conflicting results from examination of grout conditions on four bridges. In these bridges, the Cochrane Bridge (Alabama), Pasco–Kennewick Bridge (Washington State), Talmadge Memorial (Georgia), and the Fred Hartman Bridge (Texas), the HDPE sheathing was partially removed (windows cut) during inspections to allow examination of the condition of grout and wires (Grant 1991; Tabatabai et al. 1998; Dowd et al. 2001; and survey results). In the Cochrane Bridge, no cracking of grout or corrosion of MTE was reported (Tabatabai et al. 1998a). Grant (1991) also reported no grout cracks for the Pasco–Kennewick Bridge. However, Frank and Breen (1994) reported that in the Pasco–Kennewick Bridge there were small, closely spaced grout cracks perpendicular to the stay (Figure 24). The inspection of grout for the Fred Hartman Bridge indicated “fine, intersecting transverse and longitudinal cracks, with spacing between 12 and 19 mm.” These cracks were not readily evident.

It is not known whether longitudinal cracking of HDPE pipes in some bridges (such as Zarate–Brazo Largo in Argentina) affected the integrity of the grout, because no examination of the grout was reported in the literature for

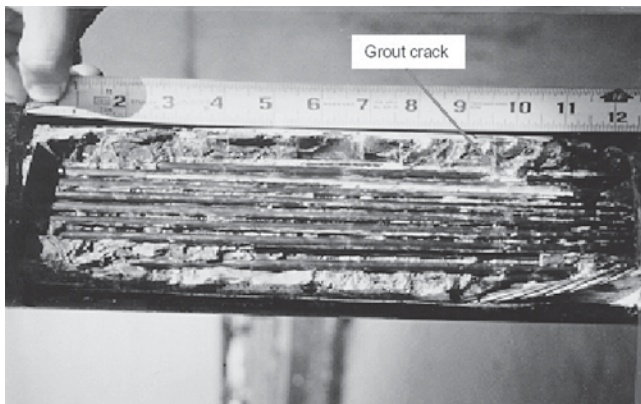

FIGURE 24 Exposed cable on the Pasco–Kennewick Bridge (Frank and Breen 1994).

these bridges. Ito (1999) reported that grout cracking has been observed on some cable-stayed bridges, but does not provide additional information. Saul and Svensson (1991) also reported grout cracking on cable test specimens.

Hamilton et al. (1998a,b) reported on accelerated corrosion tests done on eight grouted stay cable specimens, five of which were uncoated (bare) strands, one with epoxy-coated strands (some filled and some unfilled), one with a galvanized strand, and one with a greased-and-sheathed strand. These specimens were loaded and grouted inside clear pipes to allow visual examination of grout surface. Windows were cut into the pipes to simulate damage to the HDPE. Wet and dry saltwater ponding cycles were initiated to represent long-term ingress of chloride-laden air and moisture through the openings. The main objective was to determine if the cement grout can provide positive secondary protection if the first protective layer (HDPE) is breached. Hamilton et al. (1998a,b) concluded that a relatively low level of loading above the grout injection load would result in grout cracking. The salt solution was able to reach almost any location in the specimens, and the primary mechanism for corrosion was cracking of grout at sheathing breaks. According to the authors, galvanized, greased-and-sheathed, and filled epoxy-coated strands provided vast improvement over the bare strands. Corrosion was observed inside the unfilled epoxy-coated strands. Therefore, the authors concluded that the traditional grout-bare-strand HDPE system could no longer be considered a redundant system. Frank and Breen (2004) concluded that the use of portland cement grout has not proven to be an effective corrosion protection barrier.

When wires of bare strands are encased in grout fracture, the force in the broken wire redevelops a relatively short distance away from the fracture. Some qualification tests have shown multiple fractures on the same wire over a length of a few inches (Tabatabai et al. 1995). Therefore, the overall cable axial stiffness would not necessarily change when limited numbers of individual wire breaks occur, especially when those breaks are spread over some distance. This can be viewed as both positive and negative; positive because cross-section strength at locations away from fracture would remain unchanged and negative because monitoring of cable force changes (or deck profile deflection changes) would not indicate loss of section because stiffness has not been affected substantially. The global stiffness of the cable would remain essentially unchanged even when moderate wire section losses occur.

Other Fillers

Ito (1999) reported that cement grout plasticized with polyurethane has been used in some bridges. A synthetic resin material based on polybutadiene was used on two Japanese bridges (Ito 1999). Grease and wax have also been used. In the Alex Fraser (Annacis) Bridge in British Columbia, petroleum wax blocking compound was used inside the sheathing.

Wax is injected at high temperatures and solidifies when cooled, resulting in shrinkage and cracking. Ito (1999) reported that a type of petroleum wax that could be applied at ambient temperature has been developed.

Hemmert and Sczyslo (1999) reported that red lead is commonly used in locked coil cables. A coating of paint is sometimes used over the locked coil cables.

One option is not to have any fillers inside the HDPE pipe. That is the approach used on the Charles River Crossing Bridge in Boston, Maumee River Bridge in Ohio, Sixth Street Viaduct Bridges in Wisconsin, and Cooper River Bridge in South Carolina, where individually coated and sheathed strands (or epoxy-coated strands) are used inside HDPE pipe without cement grout. The Charles River Bridge is believed to be the first ungrouted parallel strand stay cable system built in the United States and marks a major shift in the stay cable technology in this country. In response to the questionnaire, the cable manufacturer for the Charles River Bridge, Freyssinet LLC, stated that the ungrouted system would improve inspectability and allows for future replacements. All of the major cable suppliers in the United States currently offer cable systems with the no-grout option.

Little et al. (2001) discussed fungal-influenced corrosion of post-tensioned tendons. They reported that bacteria have been implicated in corrosion of tendons in structures. Their experiments showed the fungal degradation of lubricating grease, which produced formic and acetic acids resulting in corrosion of steel cables. *Fusarium* sp., *Penicillium* sp., and *Hormoconis* sp. were isolated from corroding tendons in a post-tensioned structure and used in testing. The test specimens were coated with “metal soap hydrocarbon grease” before insertion into PVC sheathing. There were no indications of chlorides in the energy-dispersive X-ray analysis system spectra of the grease. This article did not refer specifically to stay cables.

Neoprene Rings

A stay cable is subjected to lateral movements as a result of vibrations. These vibrations create bending stresses at the two ends of the cable, thus increasing the potential for fatigue. To address this issue, most cable-stayed bridges in the United States have what are termed neoprene rubber “washers,” “rings,” or “donuts” placed around the HDPE pipe within the guide pipe (anchor pipe) near the ends of the cables. Figure 25, a diagram of the anchorage for the Cochrane Bridge in Alabama, shows the typical position of the neoprene washer with respect to the other components of cable anchorage.

In addition to reducing bending stresses at the anchorages, the neoprene rings also contribute to the vibration damping of the cables. Although the level of damping (attributed to the

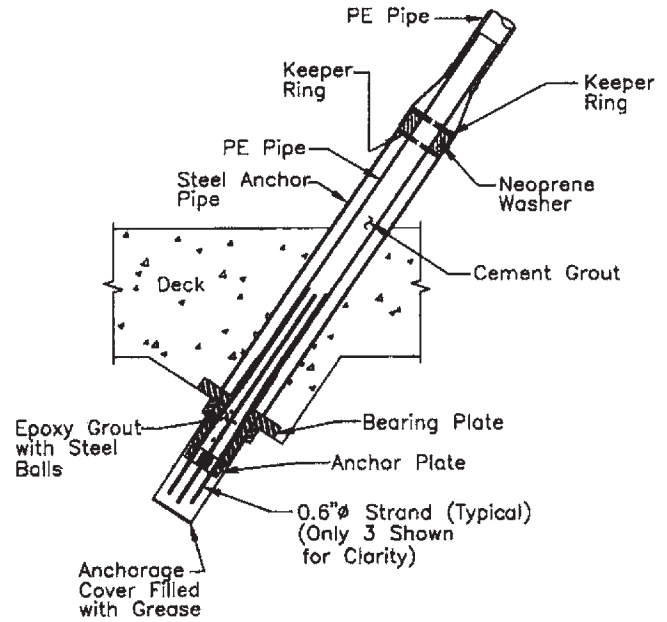

FIGURE 25 Anchorage detail including neoprene washers for the Cochrane Bridge (Alabama) (Telang et al. 2000).

neoprene ring) and its reliability is subject to debate, it is clear that problems with neoprene rings can exacerbate cable vibration problems. Telang et al. (2000) reported on problems with the washers on the Cochrane Bridge that likely contributed to excessive rain-wind vibrations. The cable was not centrally located in the middle of the steel anchor pipe (or the guide pipe); thus, the thickness of neoprene around the HDPE was variable. Also, there were gaps between the neoprene ring and the cable along the perimeter (see Figure 26). This would reduce the effectiveness of the washer both in reducing bending stresses and in damping vibrations.

The steel rings that typically hold the washers in place (“keeper rings”) can fail and result in the dislocation and misalignment of the neoprene ring (Figure 27).

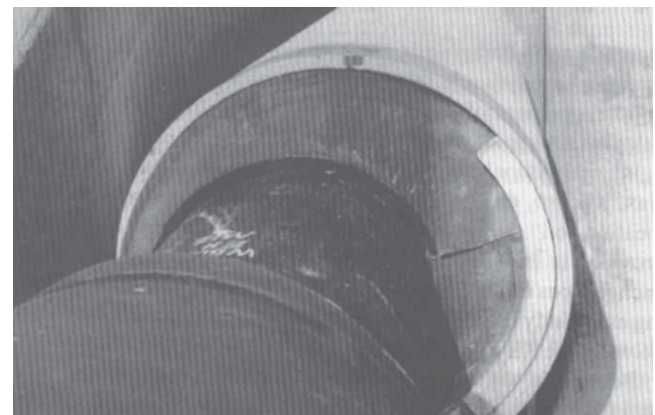

FIGURE 26 Cap between cable and neoprene washer (Telang et al. 2000).



FIGURE 27 Failure of the keeper ring and dislocation of neoprene washer (Telang et al. 2000).

Figure 28 shows the results of the survey with respect to the use of neoprene rings. Most cable-stayed bridges in the United States (64%) use neoprene rings, whereas 31% of Canadian bridges have neoprene rings.

Responses to the questionnaire indicated that seven bridges in the United States and two bridges in Canada had problems with movements of the rings out of position for various reasons, indicating that this is a relatively common problem (see Figure 29).

At least one cable supplier has developed a proprietary viscoelastic damping system that also serves the purposes of the neoprene washer. The topic of vibration damping is discussed later in this report.

Neoprene Boot

Neoprene boots are generally used to cover the gap between the cable sheathing and the end of the guide pipe near the neoprene ring. Figure 30 shows a typical neoprene boot that is in good working condition. Typically, hose clamps are used to tighten the boots against the sheathing and the guide pipe. In some cases, it has been observed that the clamps become displaced and rainwater can enter the guide pipes. Bloomstine and Stoltzner (1999) reported on water intrusion into the top

and bottom neoprene boots. They recommended using silicone filler under the boot before clamping. Responses to the questionnaire for at least three bridges indicated problems with neoprene boots.

Table 7 shows the survey responses related to problems with neoprene boots. Four bridges in the United States and one in Canada reported problems with neoprene boots. However, two of the four U.S. cases referred to neoprene boots that are not as described above.

STAY CABLE DESIGN CHALLENGES

Aside from structural strength, the design of stay cables also must address the challenges of corrosion, fatigue, vibration, inspectability, and maintainability. More recently, consideration of extreme events such as fire, ice, blasts, impacts, and earthquakes are attracting more attention in the design of stay cables. In this section, the mechanisms for corrosion, fatigue, and vibrations (including rain–wind vibrations) are first discussed, followed by a discussion of the challenges of designing stay cables for inspectability and maintainability. The PTI recommendations, including qualification tests, are reviewed. Finally, a brief outline of issues related to extreme events is discussed.

It should be noted that although these issues are presented separately, they are highly interrelated and cannot be considered independent. For example, corrosion and vibrations could have major negative influence on fatigue performance. The ability to inspect and maintain also influences durability of cables in all areas. These major structures must safely carry traffic for a long time. Therefore, a clear understanding of the durability limits and issues is very important.

Corrosion

Corrosion protection for stay cables is understandably one of the primary concerns of designers, suppliers, and owners involved in cable-stayed bridges. According to the PTI *Recommendations for Stay Cable Design, Testing, and Installation* (2001), a minimum of “two nested qualified barriers”

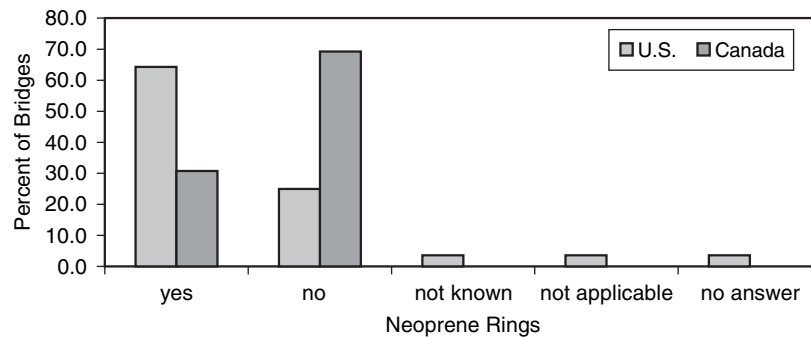

FIGURE 28 Use of neoprene rings.

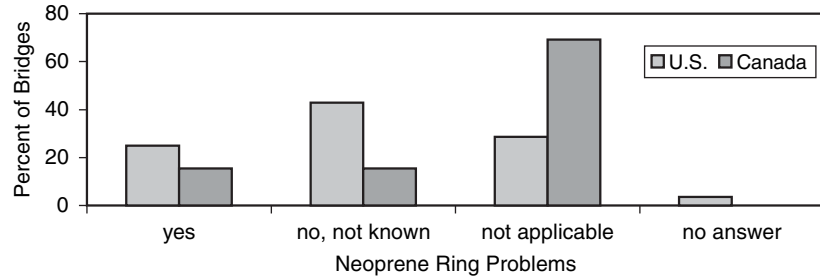

FIGURE 29 Movements of neoprene rings out of position.

must be provided for the corrosion protection of the MTE. By clearly specifying minimum acceptable levels of protection and setting performance requirements with respect to corrosion, these provisions are a major departure from earlier practices. A two-tier system is established in which the individual barriers must first be qualified through testing, followed by the testing of the nested barriers as a system. As the number of nested qualified barriers (that are compatible with each other) increase, the system redundancy and reliability is expected to improve.

It is important to realize that corrosion can be either internally or externally driven. The primary mode of protection has naturally and rightly been against externally driven corrosion (i.e., moisture and other harmful substances entering from outside). However, internally driven corrosion mechanisms have also been observed and must be addressed in design and maintenance. Examples of these corrosion mechanisms include corrosion resulting from the presence of free grout water in different components of cables.

Design of cable components for corrosion resistance should consider, when applicable, the effects of extreme temperatures, solar radiation, shrinkage or expansion of fillers, age, vibration, and fatigue on the effectiveness of the system. As will be seen later in this report, recent trends have been toward

inclusion of additional features such as vibration control and force measurements as part of the cable design. This constitutes a “system approach” to the design of stay cables. Embedded corrosion monitoring systems can also be considered as technology develops further.

There have been a number of debates over the years on the issues of corrosion and the overall health of stay cables. In a 1988 article, “Cables in Trouble,” Watson and Stafford (1988) presented an alarming picture of the condition of stay cables, indicating that cable-stayed bridges were in serious danger as a result of corrosion. The authors pointed to corrosion (of the Kurt Schumaker Bridge in Germany), vibration (of the Brottone Bridge in France), intersliding of wires, and long-term creep behavior of cables as evidence of serious challenges for cable protection. In response, in a 1991 article, “Cables Not in Trouble,” Grant (1991) countered that cable-stayed bridges were not in danger of failure from corrosion of cables. Grant reported tests on the Sitka Harbor Bridge in Alaska involving removal of six galvanized structural strand cables and their examination by magnetic, ultrasonic, radiographic, and X-ray methods. All cables were reported in “nearly new condition.” Tests were also performed on the Meridian Bridge in California and the Pasco–Kennewick Bridge (Washington State), and the steel elements were reportedly found to be without corrosion.

Saul and Svensson (1991) discussed some of the damage observed on cable-stayed bridges. In the case of the Kohlbrand Bridge in Germany, they reported on the detection during inspections of 25 broken wires on the nongalvanized locked coil cables that were protected with red lead and linseed oil

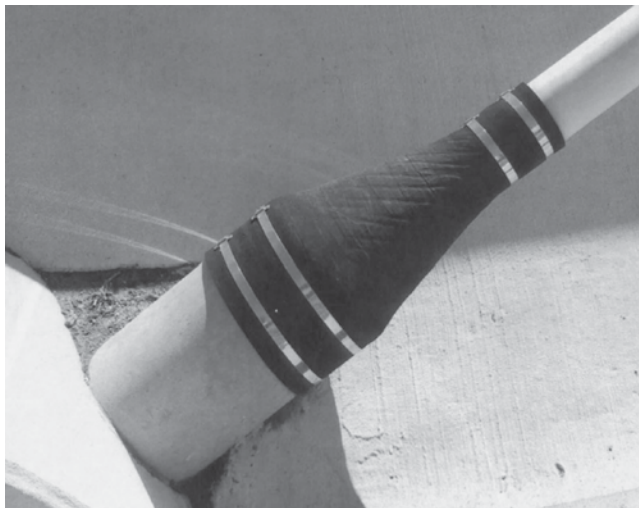

FIGURE 30 Neoprene boot (courtesy: Indiana DOT).

TABLE 7
SURVEY RESULTS—PROBLEMS WITH NEOPRENE BOOTS
(Question 4.24)

	U.S.	% U.S.	Canada	% Canada	% total
Yes	4	14.3	1	7.7	12.2
No	19	67.9	6	46.2	61.0
Not known	1	3.6	0	0.0	2.4
Not applicable	1	3.6	3	23.1	9.8
Other	2	7.1	0	0.0	4.9
No answer	1	3.6	3	23.1	9.8

(Figure 31). The bridge was under construction between 1969 and 1974, and the wire breaks were found in 1976. The authors attributed failures to many factors including misalignment of cables, missing protection at the sockets, cable vibrations, and possible effects of deicing salts.

The Lake Maracaibo Bridge in Venezuela also suffered corrosion of its galvanized locked coil cables after fewer than 18 years of service, and all of its cables were subsequently replaced in 1980 (“Cable Stays . . .” 1994). Saul and Svensson (1991) reported that the causes included inadequate maintenance and painting in the hot marine climate and a mistake made in not reinstalling neoprene boots during inspections, which resulted in a humid microclimate. Figure 32 shows the fracture of wires on the Lake Maracaibo Bridge.

Sarcos-Portillo et al. (2003) reported that inspections carried out in 1997–1999 revealed “corrosion in both cables and sockets, as well as considerable settling in the sockets” of the new cables. A “significant” amount of water was also found in most sockets. Vibration-based tension force measurements indicated major force changes. Deck profile changes were also noted. The cables were retensioned, and they recommended painting the cables and waterproofing and lubricating the sockets.

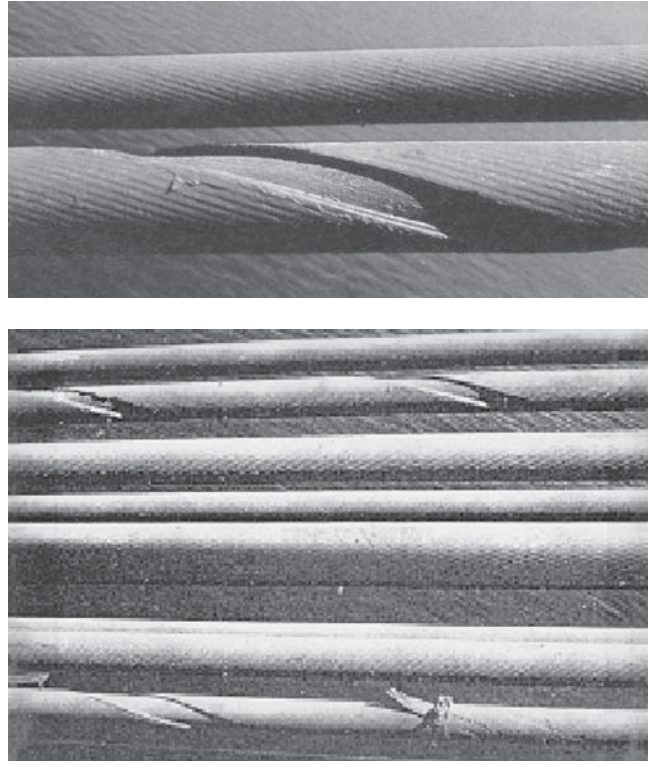

FIGURE 32 Corrosion of locked coil cables of the Lake Maracaibo Bridge in Venezuela (Frank and Breen 2004).

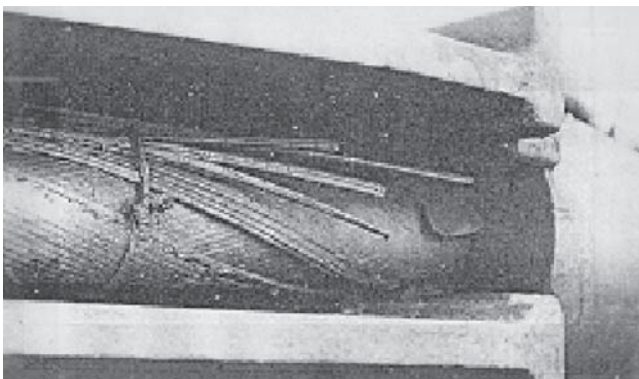
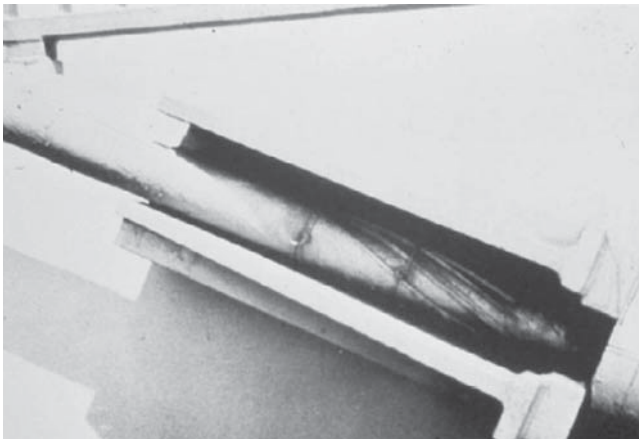

FIGURE 31 Corrosion and rupture of locked coil cable on the Kohlbrand Bridge in Germany (Frank and Breen 2004).

The response to the questionnaire for the Fox Hollow pedestrian bridge in Calgary, Canada, indicated failures of two galvanized bars used as MTEs, and replacement of a third bar. There were no sheathings or grout used on these cables. On further inquiry, the respondent reported that the failures were without any sign of prior problems. An evaluation has reportedly been performed by outside experts and the failure mode was reported as “corrosion induced fatigue.” The remaining bars were examined and a third bar was identified with a corrosion pit and replaced. Wire rope cross cables were installed after the failures. No further information was available at this time.

As discussed earlier, Saul and Svensson (1991) reported on the cracking of the grouted HDPE pipes on the Luling Bridge in Louisiana and the twin Zarate–Brazo Largo Bridges in Argentina. The longitudinal cracks in the pipes were attributed to high strains owing to grouting during hot temperatures. Subsequent cooling against hardened grout creates stresses in the pipe. Both bridges used shop-fabricated cables that were delivered on reels. In the case of the Argentine bridges, they were left on reels for up to 3 years. In the case of the Luling Bridge, failures of the butt welds between HDPE segments were also noted, which were attributed to malfunctioning welding equipment and uncoiling at low temperatures. Repair of HDPE in both of these bridges included filling cracks with polyurethane grout and wrapping them with filament tape and PVF tape (Saul and Svensson 1991).

Telang et al. (2004) reported on inspections of the cables of the Luling Bridge in 2002 and 2004. They reported that, at least in one location, exposed and rusted stay cable wires were detected. The original “epoxy repair” had deteriorated and resulted in the rupture of the protective tape and filler grout and corrosion of wires. Extensive water leakage inside sockets of deck level anchorages was observed. Water dripping from the split rings and shims was observed at most locations. It was suggested that rainwater entered the steel box at the cable exit locations through gaps in neoprene washers. It should be noted that the neoprene washers on the Luling Bridge are different from those described earlier. They surround the sheathing and are caulked to the opening at the top of the box girder (Figure 33).

The caulk that was used around the washers was weathered, cracked, or missing at some locations. Neoprene washers were removed and a video boroscope (videoscope) examination was performed. Accumulated water was found surrounding the cable inside the box. The end caps of sockets were removed to expose the button end of the wires. Figure 34 shows water

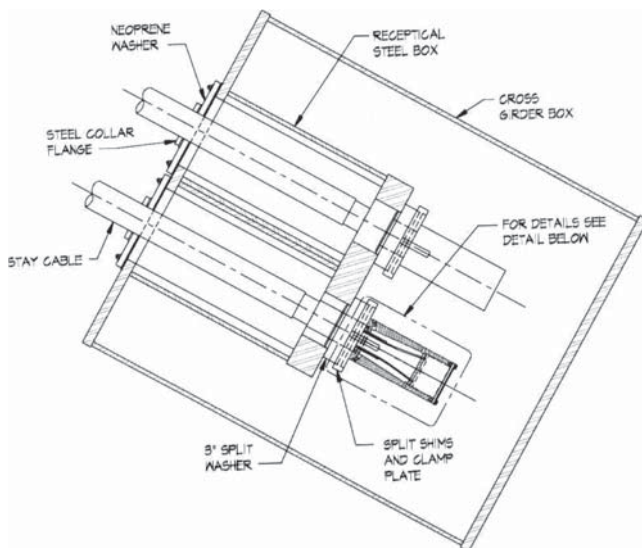
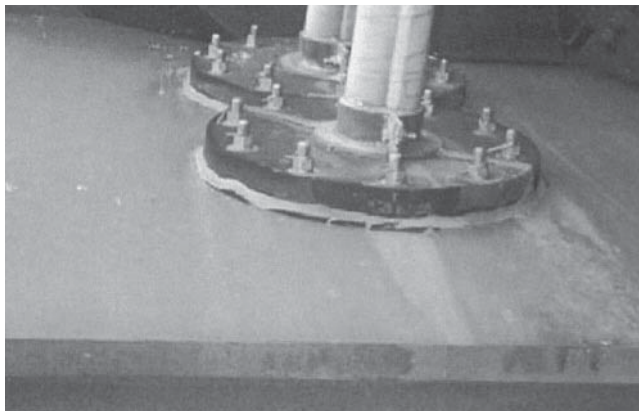

FIGURE 33 Neoprene washers on the Luling Bridge at the exit point of cables from the steel box (Telang et al. 2004).

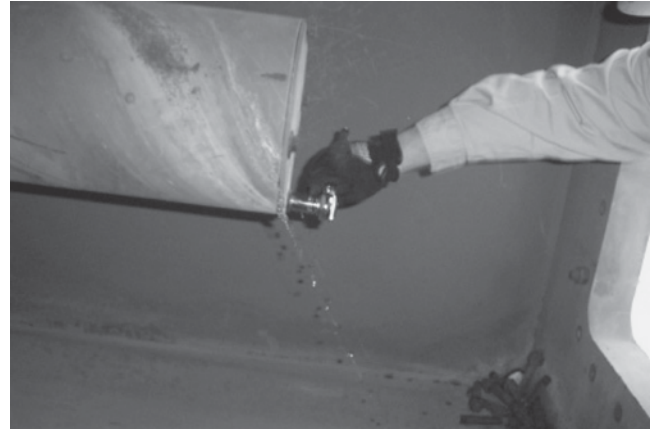

FIGURE 34 Water exiting the end cap of one anchorage (Telang et al. 2004).

coming out of one end cap as bolts are loosened. Various degrees of corrosion were noted in the cables (see Figure 35).

Telang et al. (2004) concluded, based on vibration-based measurements of cable forces, that “the cables have not suffered any significant damage.” They do not however discuss whether corrosion damage would necessarily result in global stiffness changes in grouted cables resulting in force changes. Further testing is planned for the Luling Bridge.

In the case of the Zarate–Brazo Largo Bridges, Saul and Svensson (1991) stated “five years after the repair the cables were inspected by the Argentine Federal Highway Administration and found in good condition.” It is estimated that the inspection was probably performed around 1987.

In November 1996, the first ever rupture and complete failure of a parallel wire stay cable occurred on the Guazu Bridge in Argentina, one of the two Zarate–Brazo Largo Bridges (Andersen et al. 1999). These bridges were built in the early

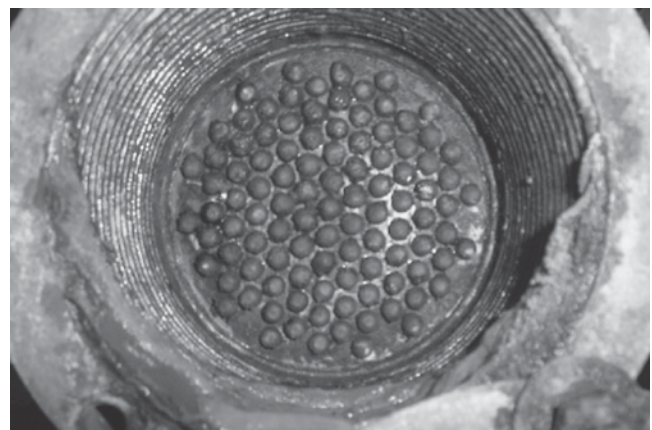

FIGURE 35 Corrosion at the end plate of one socket with wire button ends (Telang et al. 2004).

1970s. The cable consisted of grouted nongalvanized parallel wires within HDPE pipes and anchored within Hi-Am-type sockets (Andersen et al. 1999). According to the authors, “a combination of corrosion and fatigue has been found to be the cause. The corrosion has taken place due to insufficient corrosion protection of the non-galvanized wires. The likely cause is that the cement grout, which was supposed to be the main corrosion protection, was insufficient in the anchorage zone due to the presence of a non-protecting epoxy tar.” They also stated that “following intrusion of water through defects in the PE pipe or due to condensation of water inside the PE pipe, corrosion has been initiated.” A complete rehabilitation of the bridge was planned for 1999/2000.

The cable had failed in an area near the entrance to the bottom anchorage. Subsequent ultrasonic testing on other anchorages revealed damage to other cables, with up to 62% wire breaks. The cable with 62% wire breaks had adjacent cables with 41% and 20% breaks. Damage to bottom anchorages was significantly greater than to top anchorages. Cable force measurements reportedly indicated that forces in the cables had changed by as much as 20% when compared with forces at the inauguration of the bridge. This however appears to have included the effect of the lost cable, and it is not clear whether the forces at the inauguration of the bridge were actually measured or estimated by the designer. Large amplitude cable vibrations (reportedly not rain–wind vibrations) had taken place on this bridge. During emergency repairs, 13 cables were replaced.

Prato et al. (1997, 1998) reported on the replacement of all locked coil cables of the Chaco–Corrientes Bridge in Argentina. The locked coil cables had external galvanized wires. This bridge was built in 1973. Failure of several z-shaped wires (in the external layer of wires) on four cables occurred in 1986 and the cables were replaced in 1996.

Reinholdt et al. (1999) reported on the replacement of all wire rope cables of the Luangwa Bridge in Zambia in 1997. The bridge was built in 1968. The shop-fabricated cables were originally made longer than required resulting in a dip in bridge deck surface. This was addressed by installation of “cable clamps” to reduce cable length by approximately 135 mm (5.3 in.). Severe corrosion and pitting of cables was noted in 1997, resulting in replacement of all cables.

There has been some work done on the corrosion and embrittlement of high-strength wires for suspension bridges, which can be relevant to stay cables as well. Laboratory work by Barton et al. (2000) reported that “corrosion degradation of high-strength wires exceeds mere loss of load-bearing material.” Wire strength was reduced more than the cross-sectional area suggesting that “cracking or pitting effects may be present, whether induced by corrosion or by hydrogen interaction, or both.” Their studies indicated that hydrogen was absorbed into the corroded wire, with hydrogen retention being higher in galvanized wire. Corrosion results in higher embrittlement of both galvanized and nongalvanized wires.

Mayrbaurl and Camo (2004) reported on a study of structural safety of suspension bridge parallel-wire cables. They discussed issues related to corrosion of galvanized wires, including categorization of wire corrosion in four stages. They also presented cable strength models based on field assessments of wire data. However, unlike stay cables, the primary tool for inspection in main suspension cables is the removal of outside wrapped wire and the physical opening of the cable (insertion of wood wedges) to visually inspect the interior of the cable. Despite some similarities, suspension main cables and stay cable have major differences in design, materials, inspection processes, deterioration mechanisms, and anchorage systems. However, information related to long-term deterioration of galvanized wires is still valuable to the stay cable community.

In 1992, the U.S. Patent and Trademark Office issued Patent No. 5,173,982 to inventors T.G. Lovett and S.L. Stroh for a corrosion protection system for stay cables (“Immersion of Stays . . .” 1993). It is designed to keep the stay cable immersed in a lightweight, corrosion-resistant fluid within the cable sheathing. It is not known if this concept has been used on any actual stay cables.

Kitagawa et al. (2001) reported on a dry-air injection system used to reduce humidity levels inside the main cables of the Akashi Kaikyo Suspension Bridge and other bridges in Japan. The system includes salt filters to remove chlorides. Humidity measurements inside the cable reportedly show the effectiveness of the system.

Figure 36 shows survey responses with respect to moisture found inside the stay cable components. Respondents for 25%

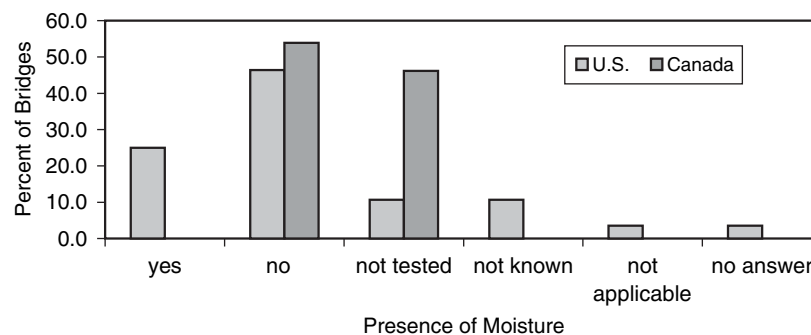

FIGURE 36 Occurrences of moisture inside stay cables.

of bridges in the United States indicated that moisture has been found inside cables. Another 21% either have not tested or do not know if moisture exists. Figure 37 shows survey responses with respect to MTE corrosion. Only one U.S. bridge and two Canadian bridges were reported to have evidence of MTE corrosion. The corrosion status of five other U.S. bridges and three Canadian bridges was reported to be unknown. As will be discussed later, assessments of MTE corrosion in cable-stayed bridges are, in many cases, very difficult.

Fatigue

The *PTI Recommendations for Stay Cable Design, Testing, and Installation* (2001) provide detailed fatigue and static qualification testing requirements for stay cables. Three cable specimens are typically tested for each bridge. These tests include two million cycles of loading, with a stress range of 28 ksi (159 MPa) and a maximum stress equivalent to 45% of the cable’s nominal strength. The number of wire breaks during fatigue tests should not exceed 2% of the total number of wires in the cable. After fatigue tests, cables are loaded statically to achieve a target load of 95% of the nominal strength or 92% of the actual strength of the strands. Some European codes such as the SETRA/CIP require fatigue tests that include a small angle change (rotation) induced at the anchorages. The PTI requirements do not have this provision at this time. The PTI recommendations also specify procedures for axial and flexural tests involving cable saddles. It should be noted however that the PTI qualification tests do not specifically address fatigue issues related to cable vibrations.

In response to the observed rain-wind vibrations on two bridges in Texas, Dowd et al. (2001) began a research project aimed at developing a set of procedures for evaluating fatigue damage in stay cables resulting from large amplitude and rain-wind-induced vibrations. This effort includes testing of cable specimens in the laboratory as they are subjected to axial loads and simultaneous cyclic lateral loads at the mid-point of the cable. The authors reported that similar tests were done in Japan on cables with 163 parallel and galvanized wires with Hi-Am-type sockets and PE pipes (without grout). In the Japanese tests, angle changes of $\pm 1.35^\circ$ produced fatigue failures at 0.26 million cycles, whereas no

fatigue failures were observed after 10 million cycles for a $\pm 0.9^\circ$ angle change.

Frank and Breen (2004) discussed stay cable bending fatigue test results in which performance of grouted and ungrouted stay cable specimens were compared. Bare strands were used and the two cable types were identical except for grouting. The number of wire breaks recorded was much higher in the grouted specimens. The authors suggest that the grout acts as an abrasive that reduces fatigue life resulting from fretting.

Prato and Ceballos (2003) studied dynamic bending stresses near anchorage sockets for grouted cables with HDPE pipes, but with bituminous epoxy replacing grout just before the anchorage (Figure 38). The authors show that the dynamic stresses in wires are higher, and stress concentration occurs, when such a discontinuity is present (i.e., grout is replaced by bituminous epoxy). They noted that shear deformations in such cases would not be negligible, and the dominant discontinuity would be that of shear stiffness and not bending stiffness. Figure 39 shows the results of the survey with respect to fatigue.

Vibrations

Since the mid-1980s, bridge owners and researchers have reported large-amplitude stay cable vibrations with increasing frequency. This has resulted in increased concern for the fatigue performance of cables. Figure 40 shows vibrations recorded on the Cochrane Bridge in Alabama, and witnessed by this writer.

Categories of Vibration

The primary types of stay cable vibrations are as follows (Irwin 1997):

- Rain-wind induced vibrations,
- Sympathetic vibration of cables with other bridge components excited by wind (parametric excitation),
- Inclined cable galloping,
- Vortex excitation (single cable or groups of cables),

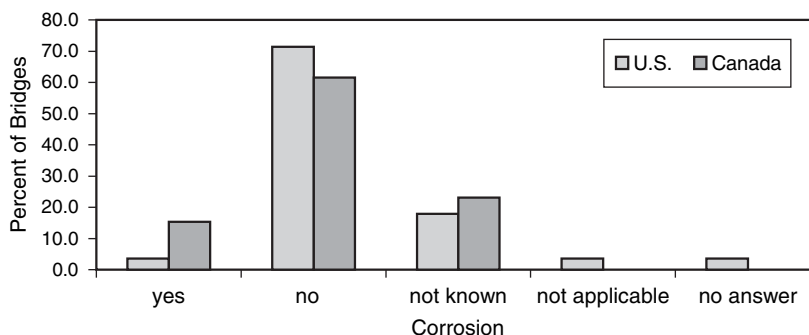

FIGURE 37 Incidence of MTE corrosion.

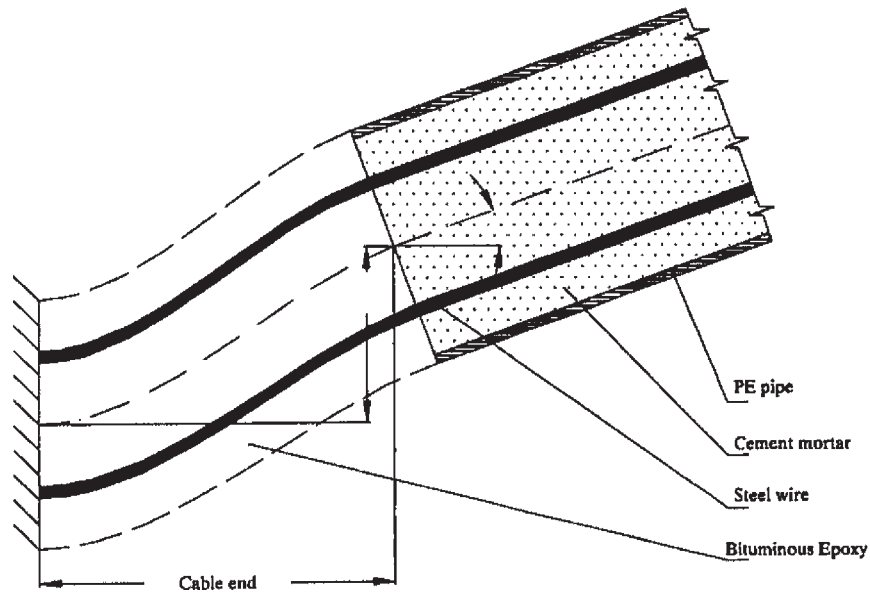

FIGURE 38 Deformations near cable anchorages with discontinuous grout (Prato and Ceballos 2003).

- Wake galloping, and
- Buffeting by wind turbulence.

The rain–wind-induced vibrations are by far the most widely reported, large-amplitude (up to a few feet) vibration phenomenon in stay cables. It was first reported on the Meiko–West Bridge in Japan in 1986 (Matsumoto 2000), and has since been reported on many bridges worldwide. This phenomenon occurs in moderate wind and rain conditions, and is believed to be caused by an aerodynamic instability resulting from the formation of water rivulets on the surface of the cable. However, uncertainties still exist regarding this phenomenon (Matsumoto 2000).

When vibrations are occurring, the speed of the wind is sufficient to maintain the upper rivulet within a critical zone (Irwin 1997). Larose and Wagner Smitt (1999) discussed the results of their wind tunnel studies and reported that rain–wind vibrations were reproduced in the laboratory for a single cable and for cables in tandem configuration. They

also reported that the rivulet changes its position with wind speed and also cable motion. Miyazaki (1999) reported that the lower rivulet is formed at lower wind speeds, and both rivulets appear at higher speeds. This is consistent with what this writer observed on the Cochrane Bridge in 1998. In this case it was the lower rivulet that appeared first; however, it was the subsequent formation of the upper rivulet that initiated large amplitude vibrations. Also, the rivulets appeared to oscillate up and down within a “wet” band as they moved down the cable (Figure 41).

Larose and Wagner Smitt suggest that the “wetable” of the cable surface is important in the formation of rivulets. They noted that a slightly eroded surface with dust particles is more “wetable,” and thus can form the rivulets more easily. This may be the reason why some bridges do not experience rain–wind vibrations for the first few years of their service. According to Swan (1997), “a very smooth surface may initially avoid the problem, until atmospheric deposits allow just enough roughness to hold the rivulet.”

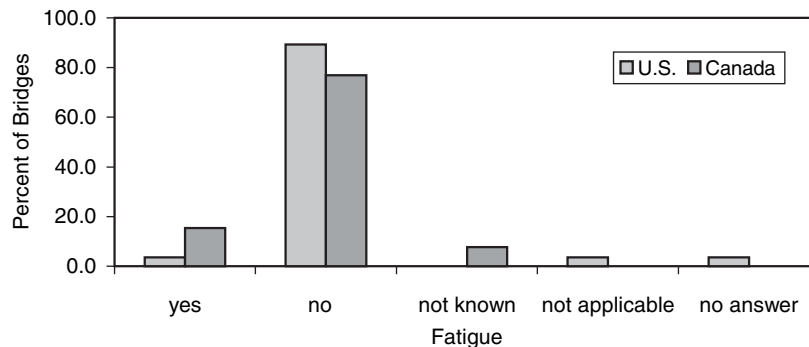

FIGURE 39 Incidence of fatigue of MTEs.

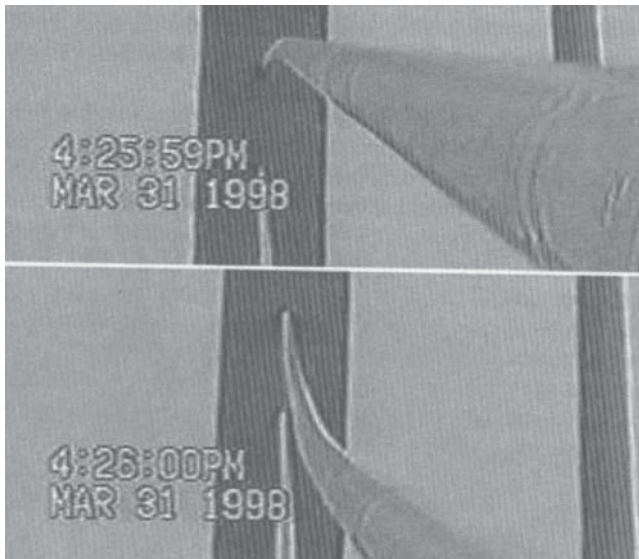

FIGURE 40 Large amplitude vibrations of the Cochrane Bridge (Alabama) (Telang et al. 2000).

Jones and Porterfield (1997) reported on the instrumentation and long-term vibration monitoring of the East Huntington Bridge in West Virginia. They reported random buffeting response, locked-in vortex-induced vibration, and rain-wind oscillations. They noted that significant displacement responses are in the lower modes of the structure. High acceleration values at higher modes do not mean high displacements at those frequencies (acceleration amplitudes are equivalent to displacement amplitudes multiplied by frequency squared). Main and Jones (2000) also reported on the instrumentation and long-term vibration monitoring of the Fred Hartman and Veterans Memorial Bridges in Texas. Figure 42a shows a sample histogram of dominant modes for one stay cable, and Figure 42b shows vibration amplitudes versus wind speed for the same cable.

Main and Jones (2000) concluded that the highest amplitude responses (which occurred during rainfall) were in the lower modes and “seemed to ‘lock-in’ to a specific mode of vibration over a wide range of wind speeds.” High-frequency vibrations over narrow wind ranges were also observed, which

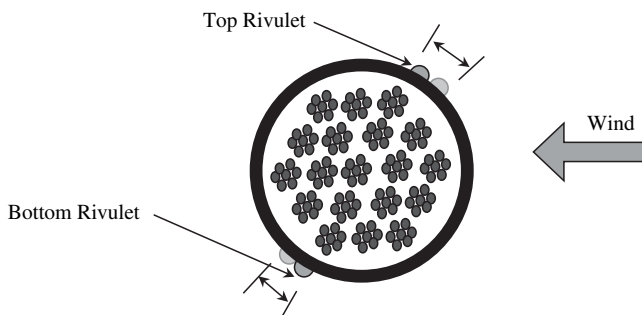

FIGURE 41 Position and movements of water rivulets during rain-wind vibrations.

were attributed to vortex-induced vibrations. Tabatabai et al. (1998a) and Lankin et al. (2000) have reported on vibration measurements and mitigation efforts for the Cochrane Bridge in Alabama. In these studies, the level of damping in all cables was measured and studies were performed to determine and optimize mitigation solutions.

Irwin (1997) recommended the following equation for controlling rain-wind vibrations:

$$S_c = \frac{m\zeta}{\rho D} \geq 10 \quad \text{Eq. 1}$$

where

- S_c = Scruton number,
- m = mass per unit length of cable,
- ζ = damping ratio,
- ρ = density of air (1.225 kg/m^3), and
- D is the cable diameter.

This equation has been adopted in the *PTI Recommendations for Stay Cable Design, Testing, and Installation* (2001) for control of rain-wind vibrations.

Tabatabai and Mehrabi (2000) used cable information from 16 cable-stayed bridges to determine the level of damping required based on Eq. 1. Figure 43 shows a histogram of required cable damping for all stay cables in those 16 bridges. These data indicate that 90% of the cables would meet the requirements of Eq. 1 with a damping ratio of 0.7%. The authors suggested that the typical first mode damping ratios for cables are in the range of 0.05% to 0.9%. Similar data for control of inclined cable galloping is also provided.

Incidences of large amplitude cable vibrations have also been reported when there is no rain, and typically at higher wind speeds. There is debate and uncertainty regarding the exact nature of all of the events that fall under this category of vibrations. It is known that cable vibrations can occur when deck or tower vibrations are occurring at frequencies close to the cable frequency (Stubler et al. 1999; Wu et al. 2003). This is also called “parametric vibrations” or “local parametric vibrations” by some investigators. Wu et al. (2003) reported that parametric vibration has been confirmed on three bridges in Japan, including the Tatara Bridge. Irwin (1997) discussed the possibility of inclined cable galloping based on the work of Saito et al. (1994) in Japan. Although circular cross sections do not gallop when aligned normal to wind (Starossek 1994), Irwin provides a possible explanation in that the wind would “see” an inclined cable as an elliptical section, and thus be able to gallop. This phenomenon has been investigated in wind tunnel tests and it was determined that separate requirements to address this phenomenon are not necessary.

Until recently, there were no vibrations reported on the Sunshine Skyway Bridge, which joins St. Petersburg and

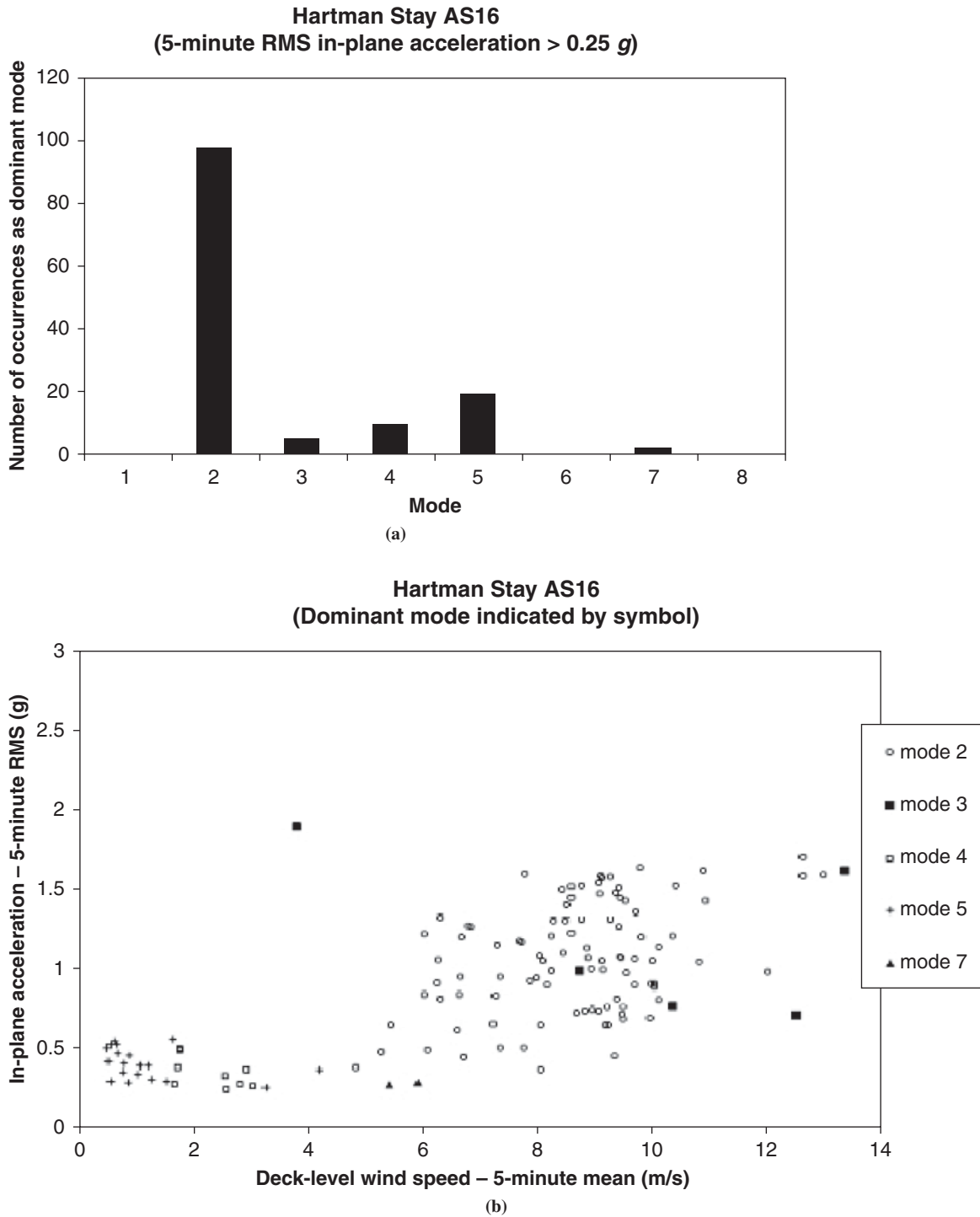

FIGURE 42 Vibration data from Fred Hartman Bridge: (a) histogram of modes, (b) vibration amplitudes (Main and Jones 2000).

Bradenton in Florida, whether rain-wind or otherwise. This bridge was opened to traffic in 1987, has grouted parallel strand cables with steel sheathing, and has two-dimensional viscous dampers (shock absorbers) installed on each cable. On April 12, 2004, Florida DOT personnel noted small-amplitude vibrations on one of the longest cables of the bridge (personal communication, S.D. Womble, April 14, 2004). It was reported that, according to National Oceanic and Atmo-

spheric Administration records, a sustained wind of 72 kph (45 mph) and gusts of up to 96 kph (60 mph) were present in the area. Wind was blowing at 90 degrees to the structures (perpendicular to cable plane). There was no rain, and estimated vibration amplitudes of up to 75 mm (3 in.) were reported. It should be noted that the reported amplitudes in this case are far smaller than amplitudes typically reported for rain-wind vibrations in other bridges.

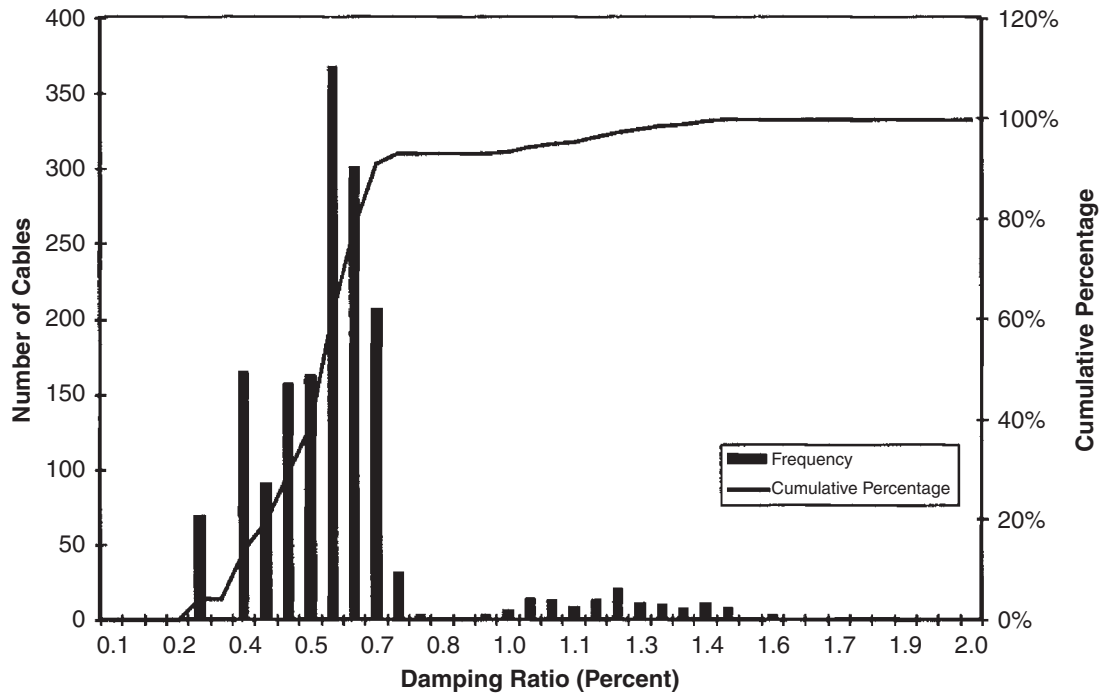

FIGURE 43 Histogram of required damping ratio for controlling rain-wind vibrations (Tabatabai and Mehrabi 2000).

Vortex excitation is likely the most common form of cable vibration, with the cables vibrating at lower displacement amplitudes and higher frequencies (mode 5 and higher) (Main and Jones 2001). Therefore, this mode of vibration is not as significant a risk to stay cables as rain-wind vibrations. Vortex-induced vibrations have been noted on the Tataru Bridge in Japan (Yamaguchi et al. 1999).

When cables are positioned in the wake of towers or other cables, they can have large amplitude wake galloping vibrations. However, the wake galloping that could occur in stay cables is typically characterized by very small cable spacing, on the order of six cable diameters (Miyazaki 1999).

Bruce et al. (1987) reported on the aerodynamic monitoring of the Luling Bridge in Louisiana 3 years after the open-

ing of bridge to traffic. They noted vortex shedding and wake-induced effects. However, they also reported a first mode response of stays to “either galloping or bridge deck motion.”

The responses to the questionnaire indicated that a sizable number of cable-stayed bridges included in the survey have experienced rain-wind vibrations. These bridges are the Cochrane Bridge in Alabama; Talmadge Memorial over the Savannah River in Georgia; Clark in Alton, Illinois; Burlington in Iowa; Veterans Memorial between Bridge City and Port Arthur in Texas; and Fred Hartman in Houston, Texas. In Canada, the Prince’s Island and Fox Hollow bridges (Alberta, Calgary), and the Hawkshaw, Longs Creek #1, and Nackawic River bridges (New Brunswick) have reportedly been affected. Figure 44 shows the results of the survey as related to rain-wind-induced cable vibrations. It is interesting

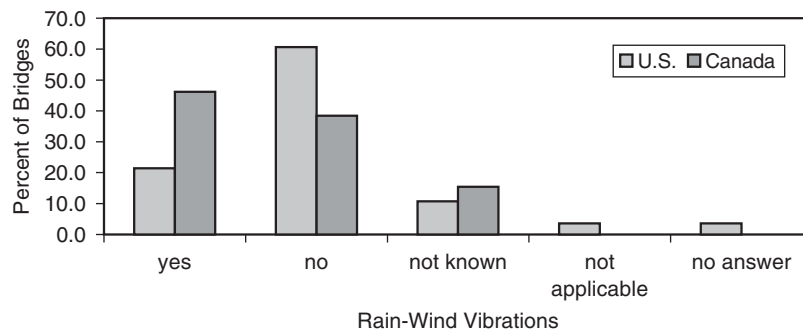

FIGURE 44 Rain-wind induced cable vibrations.

to note that the survey response for the Fox Hollow Bridge indicated rain–wind vibrations even though the stay cable is made of exposed threadbars, which would not likely promote the formation of water rivulets. It may be that, in this case, other vibration types have been mischaracterized as rain–wind.

Figures 45 and 46 show survey results with respect to the use of viscous dampers and cross cables. It appears that the most popular method of vibration control is the use of cross cables. Nearly one-third of the bridges in the United States and about one-quarter of the bridges in Canada have cross cables for vibration control, either installed from the beginning or retrofitted later to control vibrations.

Viscous dampers are used in the United States by six bridges (21.5%) and in Canada by three bridges (23.1%). In some bridges such as the Fred Hartman Bridge in Texas, both viscous dampers and cross cables are added (retrofitted) to control vibrations. In the Cooper River Bridge in South Carolina, viscous dampers will be installed, but provisions for future installation of cross cables are made in case they are needed. Figure 47 shows the survey results with respect to the use of other types of dampers.

Extreme Events

There are a number of extreme or unusual events that could affect the performance of stay cables including earthquakes, fire, blasts, impacts, and ice build-up. The earthquake design issues are generally handled through a global analysis of the entire cable-stayed bridge. However, during the fall 2004 meeting of the PTI cable-stayed bridge committee, David Goodyear noted that there potentially are cases when during an earthquake the tension force in a cable can rapidly decrease to zero or even compression. This impact loading, in a direction opposite to how the cable anchorage is designed to resist may result in permanent dislocation and damage to some crucial anchorage components, potentially rendering them ineffective and resulting in failures. Specifically, wedge systems could be affected where there is no significant resistance

to forces that would push the wedges out of their positions within the anchorage plates. This issue may be considered by the stay cable community and studied further. However, there have not been any reported cases where this scenario has materialized.

During an oral presentation at a stay cable seminar, Zoli and McCabe (2004) reported on issues related to fire, ice, and impact on stay cables. They reported that there have not been major fire incidents involving cable-stayed bridges. However, six major Interstate highway fires have occurred, resulting in significant cost and extended closures of major arteries. Zoli and McCabe suggest that wedge anchorage systems would be more resistant than some other anchorages. Zinc-filled sockets are temperature sensitive and contain materials with low melting points. Possible mitigation measures include utilization of fire-resistant cable sheathing near deck level, intumescent paints, ablative coatings, ceramics and composites. According to Zoli and McCabe, there are currently no code provisions in the United States addressing fires on bridges, although the Eurocode includes some provisions.

Regarding the effects of icing on cables, Zoli and McCabe noted that ice formations on a major suspension bridge have been periodically removed as a safety precaution. They reported on research being done on the issue of icing of cables, including assessments of sheathing performance and icing wind tunnel tests. The effects of icing on galloping vibrations of stay cables need to be studied. They discussed “ice-phobic” coatings and ultrasonic deicing systems.

Regarding impact, Zoli and McCabe discussed a number of approaches including cable “armoring” involving hybrid ceramic FRP materials.

Inspectability and Maintainability

Question 11 in the survey questionnaire asked agencies the following: what do you see as the single most important prob-

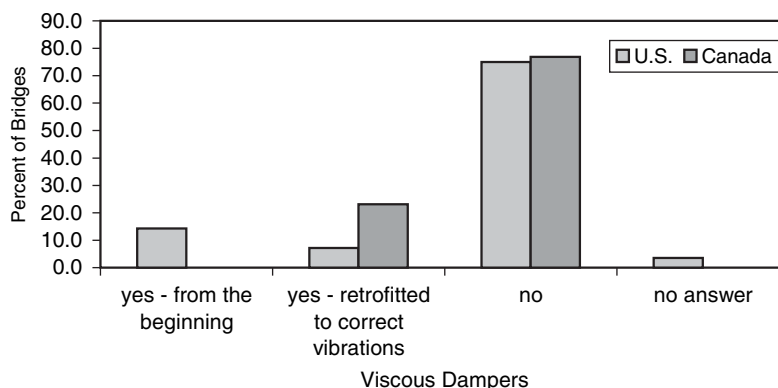

FIGURE 45 Percentage of bridges using viscous dampers.

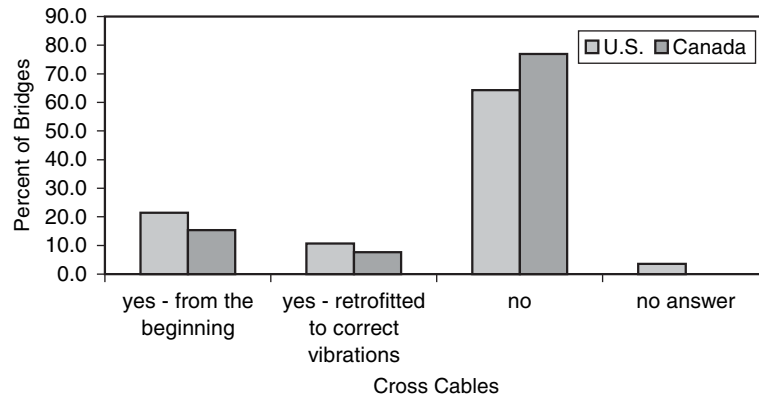

FIGURE 46 Percentage of bridges using cross cables.

lem in stay cable maintenance? The great majority of answers mentioned accessibility and inspection problems, especially in the anchorage areas. The general consensus of the respondents points to a concern by the owners about difficulties in access for inspections and maintenance. It should be noted that although there is general agreement by the stay cable community about the need to address the stay cable maintenance issue and problems, there is no universal consensus on this issue, especially with the characterization of the subject as a “problem” as indicated by one respondent. The following are some of the answers provided by respondents:

- Access and rain–wind induced oscillation.
- Access to upper anchorage.
- Inspection and condition evaluation of anchorages.
- Effective corrosion barriers that do not interfere with the ability to adequately inspect and assess the health of the cable stay system on a regular interval and within practical means.
- Accessibility for inspection and maintenance.
- Access to the cable anchorages.
- Uncertainty of cable condition and anchorages.
- Inspection, access, testing, and cost.
- Inability to inspect the elements inside the cable and anchorage areas.

- Inspecting the cable anchors and grout-filled cables.
- Hidden nature of the system.
- Access for inspection.
- Integrity of the stays. Grouted cables are impossible to inspect with a nondestructive technique (i.e., one that does not require removal of sheathing and grout); therefore, it is impossible to identify corrosion problems early.
- The largest “problem” with stay cables is that they are widely perceived of as “a problem” rather than just another bridge member with specific needs and characteristics. Stay cables have been placed unnecessarily “on a pedestal.” Although they are a very important bridge member, in current designs they are highly redundant, overtested, and (relatively) easily replaced. There is no other major bridge member that fits into all three of these categories. Let us not promote the feeling that stays are “a maintenance problem.”
- Provide end caps that are easily removed and fully protected against corrosion.
- Ability to determine the effectiveness and remaining life of corrosion protection systems for main tension elements. The configuration and construction techniques make evaluation and inspection using nondestructive techniques almost impossible.

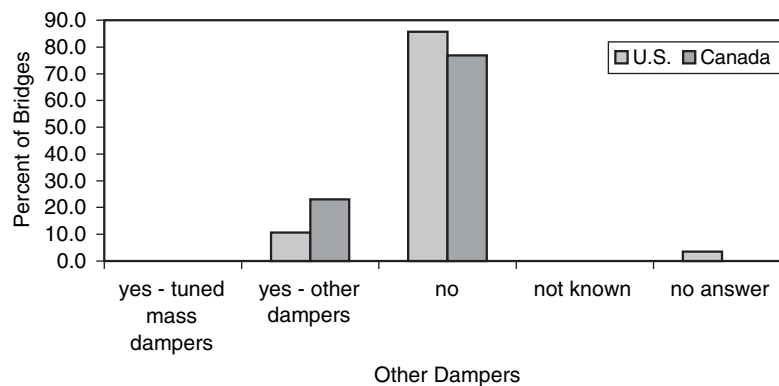

FIGURE 47 Percentage of bridges using other types of dampers.

- Lack of familiarity with this type of construction by the department’s staff, which requires assistance from the consultant community in the inspection of these elements.
- Cannot inspect cables without pulling strand every 10 years.
- Access for inspection and actual testing.
- Detection of corrosion in cables; maintenance of sheaths and boots.
- Corrosion at the anchorages.
- Migration of water into cable strands.
- Fatigue.
- Inspectability in the anchorage area.

The anchorages are typically unreachable except from the deck by special “reach-all” trucks (see Figure 48). Some newer bridges (such as the Cooper River Bridge) incorporate anchorages that are at about deck level. The end caps are generally difficult to remove, especially when filled with grout or epoxy. Even when the end caps are removed, the condition of MTEs within the anchorage area and beyond cannot be examined visually. If moisture were to enter the cable along its length, gravity would likely force it down to the bottom anchorage. There is currently no easy way to check for the presence of moisture or corrosion in the bottom anchorage, except through removal of the cap. Massive reinforced concrete or steel superstructure elements that are designed to resist anchorage forces typically surround the anchorage zones. Therefore, the sides of the anchorage zones are generally neither visible nor accessible all the way up to the top of the neoprene rings and boots.

Some recent anchorage designs (such as the 6th Street bridges in Wisconsin) have incorporated individually coated and sheathed strands that reportedly allow for future replacements of individual strands (one by one). Some recent bridges also include additional strands in the cables that are designed for removal at 10 to 15 year intervals for inspection. In some cases, allowance is made in the cables to add new strands, if needed. Permanent access platforms for use by inspectors are also an important consideration.

Question 5 in the survey asked whether the current inspection, testing, monitoring, and repair methods were effective

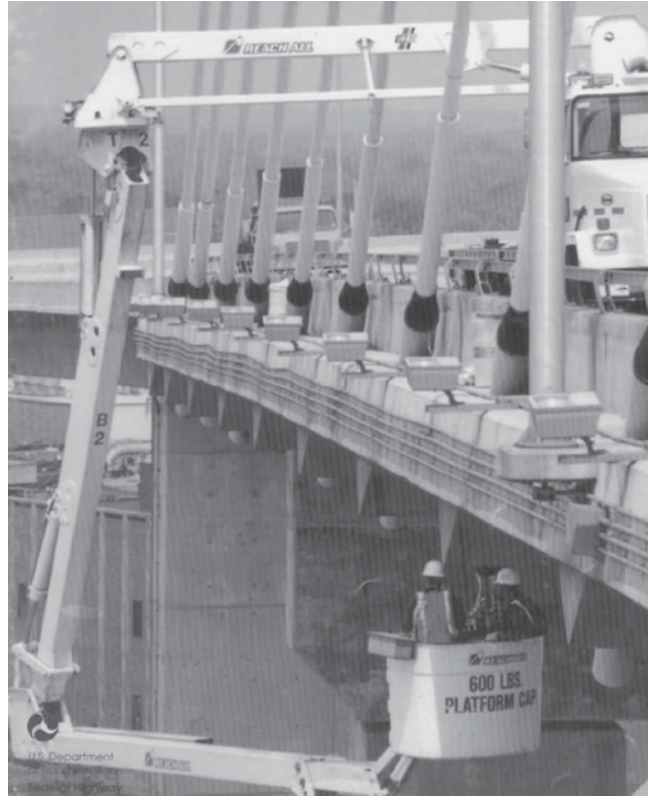

FIGURE 48 Access to cable bottom anchorage for ultrasonic testing.

and adequate. Figure 49 summarizes these responses. The U.S. respondents were far less certain than their Canadian counterparts, with less than 40% believing that they have effective and adequate methods available. One of the respondents indicated that for cables with steel sheathing the inspection methods available are limited. Another respondent referred to problems in inspection of anchorage areas and expressed the need for a technological breakthrough to address this problem.

One important question in the maintainability of a cable-stayed bridge is whether the cable (or individual strands) can

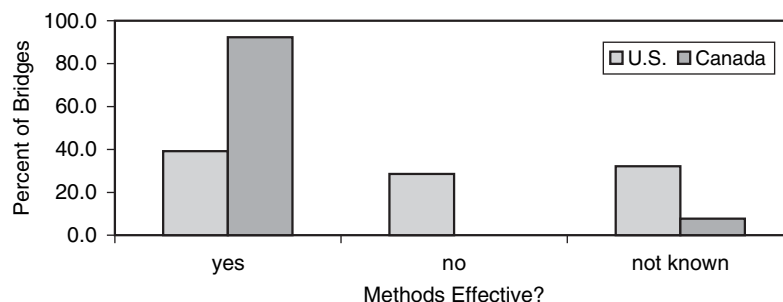

FIGURE 49 Respondents reporting that inspection, testing, monitoring, and repairs are effective and adequate.

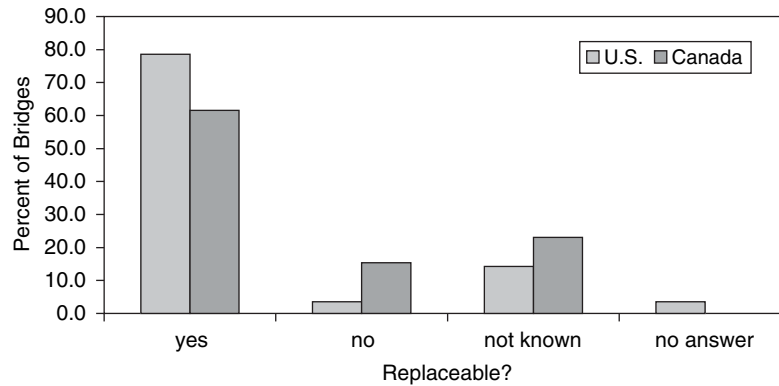

FIGURE 50 Can the cables (or strands) be replaced?

be replaced, if needed. In the opinion of respondents for 79% of U.S. bridges and 62% of Canadian bridges, the answer to this question is “yes.” Figure 50 summarizes the survey results for this question.

Another question in the survey asked whether there is an inspection and maintenance manual for the bridge. Figure 51 shows the results of the survey for this question. The great majority of U.S. bridges (71%) have maintenance manuals; however, more than 92% of Canadian bridges do not. As will be discussed later, there is a wide variation in topics discussed in individual maintenance manuals.

Survey question 10 asked whether an up-to-date resource such as a national database of information on stay cable inspection, repairs, and testing would be a useful tool. Figure 52 summarizes the responses. An overwhelming majority of responses (approximately 90%) in both the United States and Canada responded in the affirmative.

There was a wide variety of answers provided to the survey question on what the cable suppliers should incorporate into their systems to make them accessible and inspectable. The following are some of the suggestions:

- Transparent outer pipe, eliminate grout.
- Current grouted and sheathed systems do not allow for visual inspection. New stay systems (perhaps ungrouted, unsheathed systems consisting of bare corrosion-resistant tension members) need to be developed that allow for inspection of the entire stay length. Research is also needed to develop rapid, economical nondestructive evaluation (NDE) methods to determine conditions of stay cables.
- Access is a very sharp two-edged sword. If you can more easily access the cable, so can corrosive elements (not to mention potential terrorist/security considerations).
- Include a maintenance manual with clear instructions for both specific wires or full cables.
- Perhaps a permanent load cell that would permit real-time readings of cable forces at any time during the life of the bridge.
- Our cables are reasonably accessible, inspectable. Possibly a closeable drain at the lower end of the cable to allow visual inspection, sample collection, testing for corrosion product of any water in the cable sheaths.
- Different corrosion protection system at the anchorages that permits easier visual inspection. Removable sections of the HDPE and Vandal Tubes would make it easier to inspect strands near the anchorages.

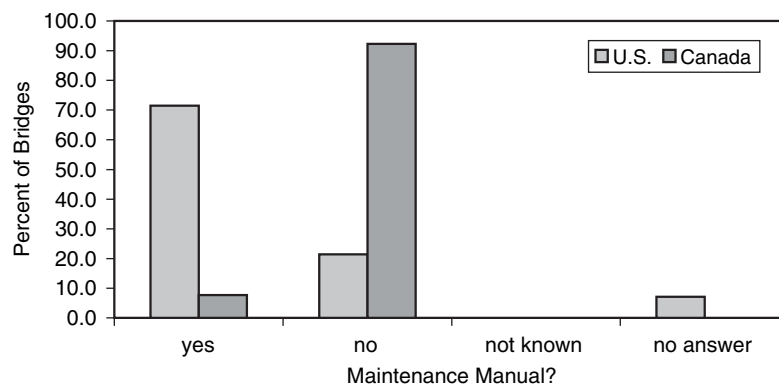

FIGURE 51 Bridges with an inspection and maintenance manual available.

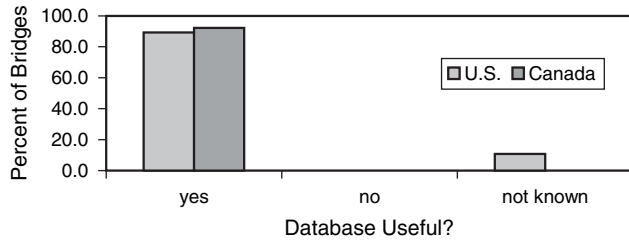

FIGURE 52 Would a national database of stay cable information be useful?

- I like the idea of hermetically sealed, ungrouted cables with fiber optic sensors throughout or exposed wire that can be directly inspected.
- Provide access on inside and outside of tower anchorage.
- Fiber optic strain gauges and redundant systems.
- We would recommend the development of individual strand monitoring capabilities that encompass the strands from anchorage to anchorage.
- For non-box bridges, an inspection traveler should be installed on the cable-stayed bridge. This should be done by the owner.
- Not possible that the cable suppliers can do any more.

- Ability to detension, inspect, and retension individual strands; ability to add strands to each cable or cable group (5%).

FABRICATION AND ERECTION OF STAY CABLES

As discussed in the previous section, stay cables can be either shop- or field-fabricated. In United States practice, and especially in recent years, field fabrication has been more common. The shop-fabricated cables come with the entire cable, including anchorages and sheathing pre-assembled and coiled on reels. The cables are then uncoiled and lifted into place. If fillers are required, they are generally placed or injected after stressing of cables. In this arrangement, the entire cable must be stressed with one large hydraulic jack. The field-fabrication method generally involves inserting strands one by one into the wedge plate in the bottom anchorage and, through various methods developed by cable suppliers, the strands are pulled through the top wedge plate. The strands are typically stressed one at a time using a single-strand jack. If required, the cable fillers (e.g., grout) would then be injected into the anchorage zones (in the case of bond socket) or the entire cable.

CHAPTER THREE

INSPECTION AND MONITORING TECHNIQUES

In this chapter, various inspection and monitoring techniques for stay cables are discussed, including their advantages and disadvantages. Figure 53 shows survey results with respect to the types of nondestructive tests performed on the cables. The most commonly used method is the vibration-based force measurement. However, the largest group belongs to the “not performed” category.

Figure 54 shows the survey results with respect to the types of sensor-based, long-term monitoring on the cables. Three respondents’ bridges in the United States and one in Canada incorporate acoustic wire break detection, whereas two respondents in the United States and one in Canada incorporate long-term vibration monitoring.

Question 6 in the survey asked respondents to comment on the effectiveness of any nondestructive test methods for stay cables of which they are familiar. Some of their comments are given later in this chapter. Others are provided here:

- Several nondestructive tests were run after an extreme oscillation event. Practically all of the methods cited in Question 6 were performed to determine if there was any loss of force in the stays. Geometric, physical, and visual tests were performed. The only discoveries were deficiencies in the original construction, which were corrected.
- The fundamental frequency of the cables was recorded. Alaska DOT&PF (Department of Transportation and Public Facilities) will monitor the cables and attempt to determine if the fundamental frequency of the cables has changed.
- The presence of the steel protective pipe limits the effectiveness of many available testing methods, particularly magnetic-based methods. Implementation of laser-based cable stay force measurements are being considered by the department to establish baseline force data for the cable stays.
- Nondestructive testing is needed to determine the condition of tension bars inside the steel casing of the cables.
- The only problem is the anchorage area. So far, no method is available for inspection. I see additional problems with inspection of the grout-filled cables.
- Vibration-based cable load determination—effective and inexpensive; X-ray—expensive, slow, very questionable ability to detect wire defects; magnetic inspection—used to rapidly, effectively inspect mine cables—but the

cables move past the inspection unit, which would need to be reversed on a cable bridge; impulse radar—good for detecting grout defects; sonic methods—dampened to the point of being ineffective.

- Four single strands are to be removed (one at each pylon) for inspection for rust every 10 years, starting in year 2014.

SHORT-TERM EVALUATION AND MONITORING

This section covers methods that can be used during limited-duration inspections of stay cables. The currently available methods, as well as new and promising technologies, are categorized and explained. The techniques that are addressed include conventional visual/manual techniques, and magnetic, ultrasonic, X-ray, laser, acoustic, and remote or contact vibration-based techniques.

As discussed earlier, Mayrbaur and Camo (2004) reported on a study of structural safety of suspension bridge parallel-wire cables. They concluded that there were currently (as of 2004) no effective NDE methods for the condition assessment of parallel wire main cables of suspension bridges. Instead, they focused their efforts on manual unwrapping and opening of cables for their evaluations.

Visual Inspections

Visual inspections are the most common approach used on stay cables. Surveys completed by a number of respondents indicated a preference for visual inspections (when feasible) and a desire to see stay cable designs that can be visually inspected.

Some bridges have dual inspection schedules, a routine inspection at 2-year (or less) intervals, and more detailed inspections at longer intervals. In the case of the Faroe Bridge between Sealand and Falster in Denmark, a three-step inspection process is used (Bloomstine and Stoltzner 1999). The bridge master performs a drive-through inspection every day. Various bridge components are inspected at yearly intervals, so that the inspection of the entire bridge is completed in a 5-year cycle. Special inspections are done if damage is noted.

During typical inspections of stay cables, the entire surface of the cable is visually inspected at close range, followed

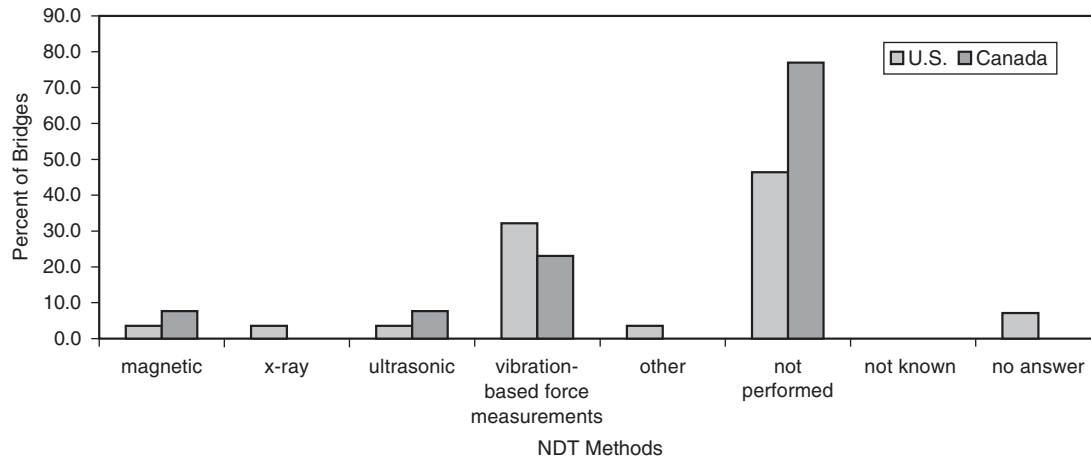

FIGURE 53 Types and levels of nondestructive testing on stay cables.

by an inspection of neoprene boots and neoprene rings (by removing neoprene boots), visible surfaces of guide pipes, and accessible anchorage surfaces. General visual inspections of stay cables typically involve the following:

- Identification of longitudinal or transverse cracking or excessive bulging in the sheathing, as well as damage at connections to dampers or cross cables, if any.
- Inspection for cable alignment irregularities including waviness or excessive sag. Cable sag can be estimated (measured) using optical devices or through video or photo image processing. Cable angle can be measured with an inclinometer at specific points.
- Identification of changes to bridge deck elevations.
- Examine damage to protective tape wrapping (tears, cracks, and delaminations).
- Examine damage to sheathing, especially when PVF tape is not used. Attention should be paid to cracking in the sheathing, especially at high stress areas.
- Identification of damage to connections between anchorage pipes and cable sheathing.
- Inspection for damage, loosening, lack of water tightness, and deterioration of neoprene boots and band clamps.
- Inspection for damage or dislocation of neoprene rings and keeper rings, if applicable.
- Identification of gaps between the neoprene rings and the sheathing.
- Examination of sheathing surface inside the guide pipe through a boroscope or other means, looking for damage or deformation to the sheathing near the anchorage.
- Review of cracking or damage to guide pipes or evidence of the impact of cable components on guide pipes.
- Examination of surface conditions on the visible anchorage components including ring nuts, end caps, and bearing plates.
- Examination of visible parts of saddles for damage, corrosion, and cracking, if applicable.
- Review of evidence of moisture or fillers (such as grease) exiting the anchorage components. If there is an access port at the end cap (ideally at the lowest point), it can be opened and examined for moisture or moisture-contaminated grease.
- Removal, in some cases, of the end caps on the sockets to allow for visual inspection of the anchorage plate and anchorage devices and to see if there is moisture or corrosion inside.

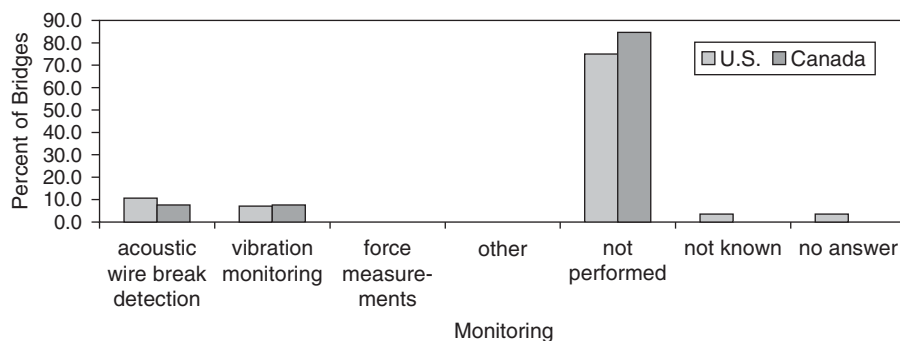

FIGURE 54 Types and levels of sensor-based, long-term monitoring.

- Inspection of the cross tie cables for sagging (losing their force and need to be retensioned).
- Inspection of damage or cracking on components of cross tie cables. Evidence of fretting and fatigue, especially at connections, are of particular interest.
- Examination of dampers, if any, as per recommendations of manufacturer.

Some maintenance manuals recommend inspection of stay cable surfaces using binoculars during routine inspections and close viewing during detailed inspections. However, it should be noted that the bridge maintenance community in general does not view the use of binoculars for bridge inspections positively, as it may discourage the preferred method of close inspection.

The access to cable components can be gained through “reach-all” trucks, and lifts or cranes with “baskets.” In some bridges, special inspection vehicles for stay cables have been designed to allow for easier access to cables. For example, the Luling Bridge in Louisiana has two trolleys designed for inspections of cables (Elliott and Heymsfield 2003). They were reportedly built in 1985 at a cost of \$3,000. Only the maintenance lane and one traffic lane need to be closed during inspection. The trolley is a steel frame carriage with a detached basket (see Figure 55). Two inspectors and equipment totaling 1780 N (400 lb) can be used. A wire rope is used to pull the trolley up the cables. However, there are indications that changes to the design of the trolley are recommended by DOT personnel to increase redundancy and provide a braking system. This system is reportedly suitable for larger diameter cables only.

For the inspection of the Dame Point Bridge in Florida (“B&N Creates Custom Device . . .” 2005), the inspection team custom designed a rolling device (Figure 56). The weight of the device was an important factor in the design, because the inspector has to carry several hundred feet of rope and other inspection equipment (“B&N Creates Custom Device . . .” 2005).

In Denmark, a carrier for inspection of the main cables of a suspension bridge has been developed (Figure 57).

In their written comments, many survey respondents emphasized the desirability of finding effective ways to inspect cables visually.

Vibration-Based Cable Force Measurements

The vibrating chord theory presents a simple relationship between the tension in a string (T) with its mass per unit length (m), its length (L), and its natural frequency (f) as follows:

$$T = 4L^2 f^2 m \quad \text{Eq. 2}$$

In its simplest form, a stay cable can also be approximated as a vibrating string. If its natural frequency could be determined then, knowing all other parameters, the cable force could be determined. A number of researchers have used accelerometers installed on cables to measure the cable’s natural frequency and estimate the cable force (Casas 1994). However, in some cases, measurement of cable frequencies on a large number of stay cables on a major bridge can be time consuming. The assumptions inherent in Eq. 2 are also not strictly valid in stay cables. Stay cables have bending stiffness,

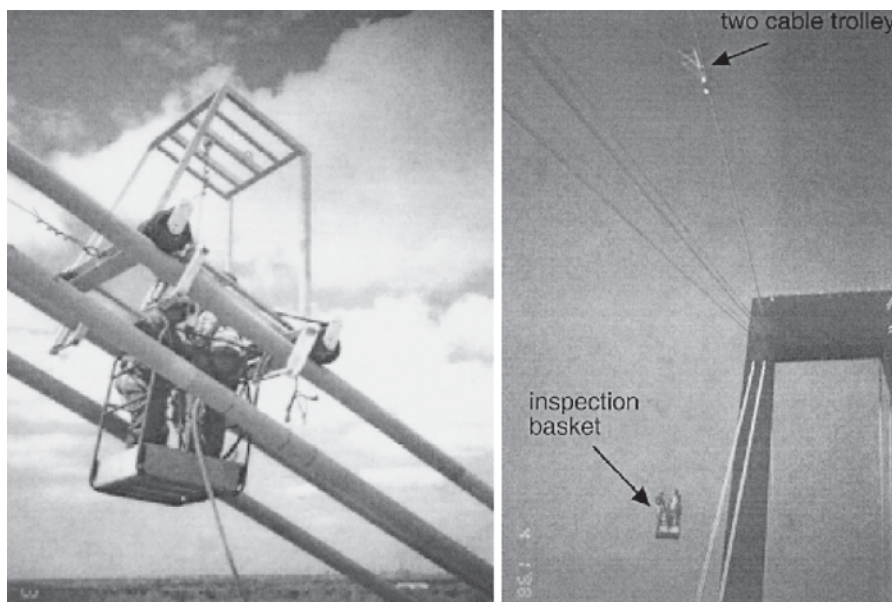

FIGURE 55 Trolley used for inspection of Luling Bridge cables (Elliott and Heymsfield 2003).



FIGURE 56 Rolling device for inspection of the stay cables on the Dame Point Bridge (“B&N Creates Custom Device . . .” 2005).

whereas Eq. 2 assumes zero bending stiffness. Cables also sag under their own dead weight and have other complicating factors such as neoprene rings, viscous dampers, and variable stiffness along their length (e.g., anchorage sockets), that further complicate the analytical relationship. To address these issues, FHWA funded a research project in the mid-1990s to develop a laser-based noncontact method for cable vibration measurements in the field (Angelo 1997). The effectiveness of using a laser Doppler vibrometer was established for measurements of ambient cable vibrations from distances of up to several hundred feet (Tabatabai et al. 1998b). More importantly, nondimensional relationships that included the effect of cable bending stiffness, cable sag, and so forth, were developed for a more accurate estimation of cable forces (within 1% to 3% accuracy) using measured frequencies. This approach has been used on several U.S. cable-stayed bridges including the Weirton–Steubenville Bridge in West Virginia, Varina–Enon Bridge in Virginia, Cochrane Bridge in Alabama, and Sun-

shine Skyway Bridge in Florida. Figure 58 shows the laser measurement approach in the field.

Cunha and Caetano (1999) used the developed laser measurement approach to measure cable frequencies on the Vasco de Gama cable-stayed bridge in Lisbon, Portugal. Also, the survey results in this study indicated that the Ministry of Transportation personnel in Quebec, Canada, have themselves measured the cable forces on the Galipeault Bridge using the same laser-based method.

Yamagiwa et al. (1999) presented a method for simultaneous identification of bending stiffness and tension in a cable using vibration measurements. Experiments on a spiral rope for a cable-stayed bridge were performed and the authors reported good agreement between measured and calculated values.

It should be noted that results of similar accuracy could alternatively be obtained by simply attaching an accelerometer on the cables to determine frequencies, and then using the available equations to estimate forces. Whether the accelerometer or laser-based approach is selected, it is important to reemphasize that one could not necessarily conclude that there has not been a section loss because cable forces have not changed. This is especially true in grouted cables where broken wires redevelop over a short distance. Unless and until wire breaks result in global stiffness changes in the cable, section loss could not be inferred from cable force measurements.

The following comments related to vibration-based force measurements were provided by the respondents to the survey:

- “Laser-based force measurements will give results that will indicate if a cable is deviating from the trending val-



FIGURE 57 Carrier for inspection of main cable of suspension bridge in Denmark.

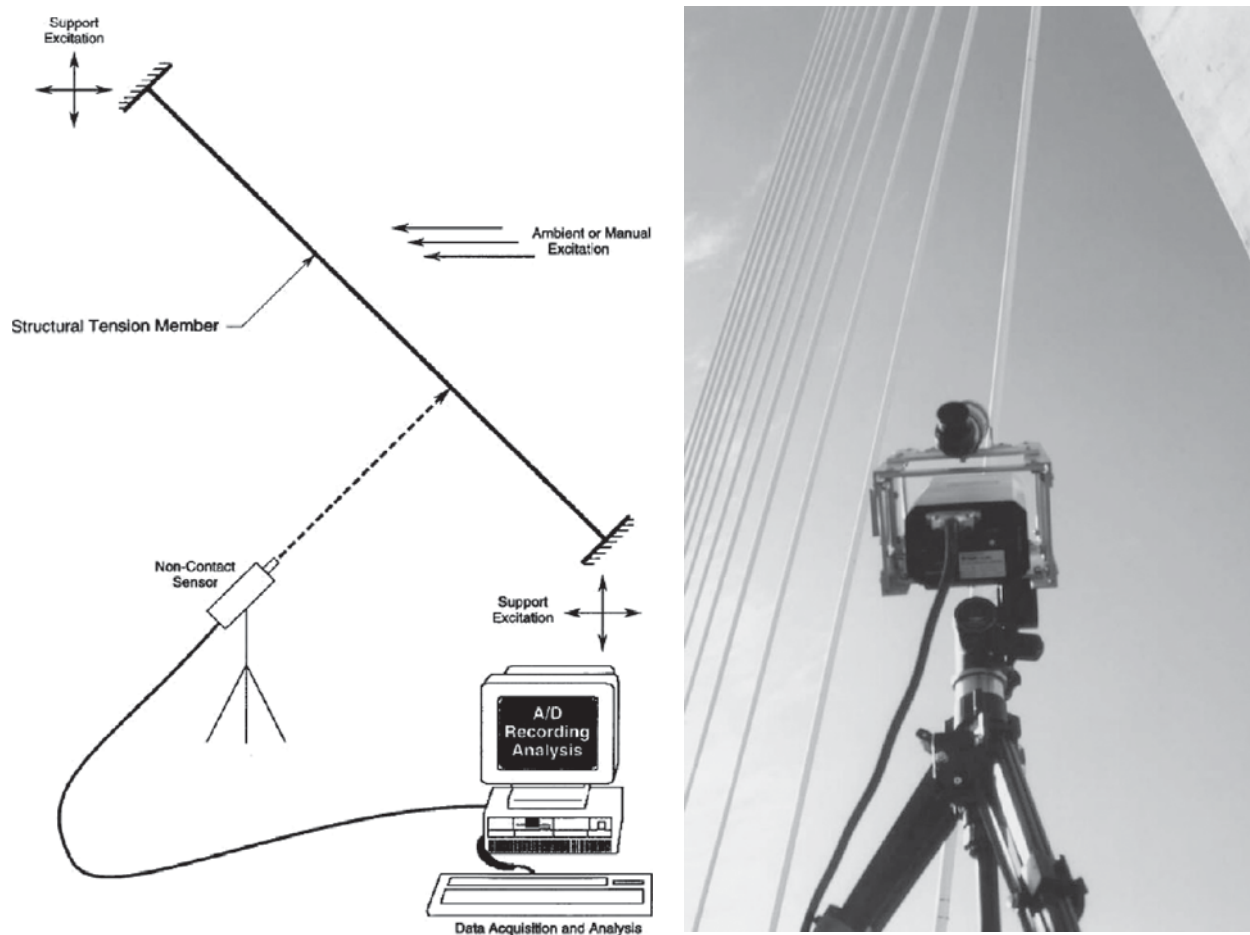

FIGURE 58 Use of laser doppler vibrometer for stay cable vibration and force measurements.

ues of the other cables. It may not give you an accurate value of the force in a cable. It is relatively easy and inexpensive to perform.”

- “TxDOT has employed vibration-based force measurements to refine the model used for designing viscous dampers on each of the cable stay bridges. The technique seemed to give good correlation cable dimensions and damping requirements. The technique requires some traffic control and depending upon the number of lanes carried by the structure could produce minor-to-significant traffic disruption. At least one lane and the shoulder will need to be closed; therefore, if the bridge is narrow with a small number of lanes carrying two-way traffic the disruption could be considerable. This could last for several weeks if there are a large number of stays that need to be tested. The cost can run anywhere from \$50,000 to \$75,000 per bridge per test event depending upon the size of the structure.”
- “Laser-based force measurements were utilized in the initial in-depth inspection of this bridge in 1999. The cost incurred was approximately \$35,000, with minimum impact on traffic.”
- “Force measurements on selected MTEs will be performed as part of the SHM system with the use of uni-

axial accelerometers to determine frequency of the cable and relate back to force.”

Other Methods of Measuring Cable Forces

Some stay cable suppliers and contractors have used measurements of cable sag to estimate cable forces. Cable sag is defined as the maximum vertical displacement of the cable with respect to a line connecting its two ends. There is a simple inverse relationship between the sag of a cable and its tension. However, the results of the survey in this study did not reveal any instances where inspectors have measured cable sag as part of their routine inspections of cable-stayed bridges. Photogrammetric or optical methods can be used to allow inspectors to measure cable sag from the deck level without the need for specialized assistance.

Another option for cable force measurements on new cables would be to install low-profile load cells under the anchorage. This could be an effective, although relatively costly option. Contractors have also used a method called “liftoff” to measure forces. In this approach, a large hydraulic jack is used to lift the anchorage off of the anchorage plate. The

force required for the liftoff is the cable force. This method is cumbersome and costly, especially for inspection purposes.

Force measurement sensors on selected individual strands on a cable are likely to be developed based on magnetoelastic effect or other effect in the near future. Some cable suppliers are working to develop force-measuring systems for their cables. The sensors can be applied to the entire cable or to individual strands. If individual strands are instrumented, the total force is estimated based on an assumption of equal forces in all strands.

Ultrasonic Assessments of MTEs in Anchorage Zones

Ultrasonic techniques have been used for assessment of MTEs in stay cables. Desimone et al. (2001) studied the pulse wave propagation along a bar (wire), and reported on experiments on wires with and without notches and grooves of various depths. The first known application of ultrasonic testing for assessments of wire conditions in stay cable anchorages was by Suzuki et al. (1988). The cable anchorage in that case was a Hi-Am-type socket (a steel socket filled with an epoxy–steel ball compound) containing steel wires terminating at button heads. In this method, an ultrasonic transducer is coupled to the end of each wire or button head and a high-frequency stress wave is sent into the wire. The reflections are monitored by the same sensor and displayed. A trained technician can view the record and decide if a wire break has occurred. It should be noted that ultrasonic pulses could travel a long distance along a wire if that wire was free in air. However, as the wire is enclosed by grout and/or anchorage epoxy, a significant attenuation of the pulse reduces the effective length over which this method can be used. Suzuki et al. (1988) reported that the depth of wire-break detection for a Hi-Am-type anchorage was a few meters. However, a few meters would theoretically be sufficient for inspection of most anchorages.

Following the failure of a cable on the Zarate–Brazo Largo Bridges in Argentina, a series of ultrasonic tests was performed on the remaining anchorages. The failure was noted in the cable near the entrance to the anchorage socket (Hi-Am-type). Prato et al. (1997) reported on the ultrasonic tests undertaken in which a large number of wire breaks were detected in various cables. Figure 59 shows an ultrasonic test record indicating a wire break. However, it is not clear if the test record shown in the figure is indicative of the clarity and definiteness of a typical ultrasonic test record or perhaps a representation of one of the better results.

The first application of ultrasonic testing on seven-wire strands was done on 12 anchorages of the Cochrane Bridge in Alabama (Tabatabai et al. 1998a; Ciolko and Yen 1999). Figure 60 shows testing on a tower anchorage.

There are further complications with stress wave transmission through a seven-wire strand. Typical ultrasonic transduc-

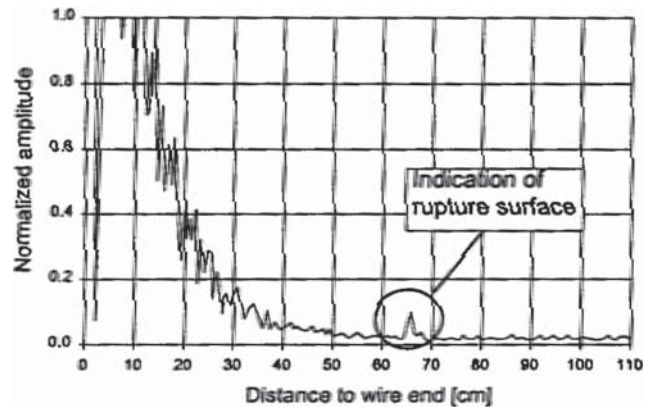

FIGURE 59 Typical ultrasonic test record of broken wire (Prato et al. 1997).

ers must be properly coupled to the cut-and-ground ends of the strands. Because the six perimeter wires wrap around the center wire and are in contact with each other, wave transmission is more complicated than in single straight wires.

It is very important that an existing anchorage of an identical or similar type be made available (or a mock-up made) before field testing to calibrate the results for known defects and their locations. The operator's experience and ability is crucial, as judgment is required when interpreting results. There are however no known systematic and rigorous research programs performed to date that are aimed at quantifying the degree of accuracy of this method for various anchorages, and ways of improving the interpretation of results.

Magnetic Methods

When a magnetic field moves along the length of a cable containing steel MTEs, presence of corrosion or fracture in the wires changes the magnetic field. Sensors can detect such changes and produce electrical output as a result. Figure 61 shows a magnetic flux leakage signature, with the characteristic shape representing the flaw. The horizontal axis is the posi-



FIGURE 60 Ultrasonic testing of cable anchorage (Ciolko and Yen 1999).

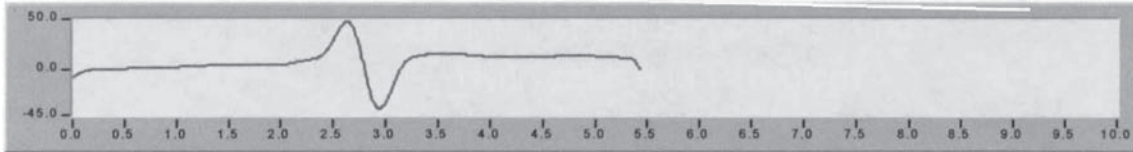

FIGURE 61 Signature from a flaw in a steel cable (*courtesy*: A. Ghorbanpoor, University of Wisconsin–Milwaukee).

tion along the scanned length of cable. The size of flaw and distance from the sensor determine the signal amplitude and shape. The method to identify location and extent of damage based on the above approach is variably called magnetic perturbation, magnetic flux leakage, or magnetic induction.

Barton et al. (1989) developed the first prototype device for inspection of the free lengths of stay cables based on the magnetic perturbation method. This device would surround the cable and move along its accessible free length. The first application of this device was on the Luling Bridge in Louisiana. Teller et al. (1990) also reported on the use of this device on the Pasco–Kennewick Bridge in Washington State. This system was effective; however, because of its large size and weight, it was difficult and time consuming to position and move the device from one cable to another. It was also limited to the cable free length and could not access the anchorages.

EMPA, a materials science and research institution in Switzerland, has developed a magneto-inductive evaluation system for stay cables (Bergamini et al. 2003). This system was used to evaluate the conditions of 68 cables of the Rama IX Bridge in Thailand in 2001. EMPA’s device uses an electromagnet instead of permanent magnets to allow magnetic saturation of large stay cables. The current system can travel along the cable and detect the position of flaws along the length of the cable and provide a “qualitative statement about the position and size of the flaw within the cross section.” EMPA is trying to increase the amount of information obtained so that additional information on the size and position of flaws within the cross section can be determined.

Weischedel and Hohle (1995) discussed the use of dual-function electromagnetic (EM) instruments for evaluation of stay cables. They referred to the following two different and distinct EM inspection methods:

1. Localized flaw inspection (LF inspection).
2. Inspection for loss of metallic cross-sectional area (LMA inspection).

Weischedel and Hohle suggest that the LF inspection (as used in the United States and elsewhere) is based on differential sensors that cannot measure gradual changes in condition such as corrosion, wear, and so forth. They assert that an absolute sensor is required to measure such changes. A dual system would include the two different sensor types and would measure LF and LMA at the same time. They reported

that EM methods had been used in Germany for bridge stay cables for 25 years (the publication date of the paper was 1995). In addition, they referred to a device that can travel along the cable and that uses four differential sensors (LF type) to detect wire breaks. They also discussed the effects of trapped magnetic debris on the accuracy of LMA measurements.

In the United States, Ghorbanpoor (1999) developed a MFL robotic device for NDE of strands within prestressed concrete girders. This device would attach itself to the bottom flange of typical I-girders and would automatically travel the length of the beam.

Kitagawa et al. (2001) briefly described using the magnetic flux method to detect corrosion in hangers of a suspension bridge in Japan. Wichmann et al. (2003) described an EM resonance measurement method for identification of localized fractures in tendons. The idea is described as follows: the tendon is considered as an “unshielded resonator located in a material with electromagnetic loss (e.g., concrete). An electromagnetic wave of variable frequency is coupled into the end of the tendon.” The reflection coefficient is scanned over a frequency spectrum to measure resonance frequencies. The authors suggest that the method has the advantage that only one end of a tendon has to be accessed.

The MFL methods described previously have not been applied to stay cable anchorages because the magnet and the sensors cannot physically reach around the anchorage within a reasonable distance. However, if future anchorage designs allow such access, then this methodology could potentially be developed for anchorages as well.

Video Monitoring (Photogrammetry)

Aas-Jakobsen et al. (1995) used a video camera to measure the amplitude of stay cable vibrations on the Helgeland Bridge in Norway. Elgamal et al. (2001) considered the use of video monitoring on an FRP bridge. Video cameras with sensor data activation and target tracking software were also considered.

Dr. Derek Lichti of the Curtin University of Technology (Perth, Western Australia) has used video monitoring of beam deflections in static tests, and reportedly plans to perform dynamic measurements at 50 Hz frequency or greater. Software has been developed to capture image sequences from two video cameras at 50 Hz. Targets are imaged and, using

photogrammetric algorithms, “sub-pixel target measurements” are obtained and transformed into three-dimensional coordinates. At least one cable supplier plans to investigate and incorporate some form of video monitoring for stay cables. In addition to dynamic measurement from a distance through a camera, photogrammetric techniques can also be used for static measurements such as cable sag.

This synthesis effort did not identify methods to obtain a three-dimensional image of the entire stay cable for comparisons with future such images. However, some forms of scanning (perhaps laser-based) may eventually become available.

Radiography

Nondestructive test methods based on radiography have been used in civil structures and, in limited cases, on stay cables. The radiation source in radiography is either X-rays or gamma rays. There are safety hazards associated with both of them. Special high-voltage machines (X-ray tubes) produce X-rays, and gamma rays are produced from radioactive isotopes. Plarucki and Eberhard (1995) presented a summary of various imaging technologies for reinforced concrete, including radiography. General radiography produces two-dimensional images, whereas computed tomography can produce cross-sectional images of the three-dimensional object.

The anchorage sockets of the Sacramento River Bridge (Meridian) cables (wire rope cables) were inspected in 1988 using a 6.0 MeV portable linear accelerator. The inspected sockets were 203 mm (8 in.) in diameter, and a length of 150 mm (6 in) was inspected. According to California DOT personnel, the testing was successful and clear images were obtained. However, the process was considered lengthy and costly. There were no indications of distress detected.

FHWA has constructed a mock-up of a stay cable component for the C&D Canal Bridge in Delaware. This mock-up included wire and strand breaks and grout voids. The mock-up was tested by a company that specialized in radiographic testing. Field testing on this bridge saddle has not been done. The Delaware DOT has investigated this method and offered the following observations in response to the survey:

X-ray imaging of the cable stays was considered and dismissed. Several concerns were encountered with this method including protection of public and working personnel during the exposure, access and holding the equipment at the higher elevations of the cable stay, and scheduling of the equipment. Interpretation of the image was also a concern. It is believed that the multiple materials (steel, grout, steel strand) which comprise the cable stays combined with the changing geometry would make interpretation of the image difficult and would not allow for an accurate understanding of the conditions. Our understanding is that the X-ray imaging would only be able to detect gross section loss of the stay and is not precise enough to discern the onset or early stages of corrosion. Finally, when the X-ray imaging method was considered, it only allowed a view of a discrete section of the cable stay as opposed to a global or ‘traveling’ operation, which would allow an investigation of the entire length of the cable stay.

The following is a survey comment received regarding the Meridian Bridge in California:

Used radiographic testing once on this structure. It was costly and impractical, but did appear to give satisfactory results. Would not use this method for routine inspections on this bridge.

Telang et al. (2004) performed tests on cable mock-ups to determine whether a low-energy X-ray method could be effective in identifying splits in PE sheathing, previously repaired splits in PE sheathing, damage to external tape, and grout void or damage. They made the following overall assessment:

The low-energy, X-ray radiography was effective for almost all types of flaws in the cable specimen. However, the use of radiography is associated with higher cost and slower process, and the results require expert interpretation.

A number of manufacturers produce portable radiographic systems for field applications, especially for grouted post-tensioned tendon applications (Brown and St Leger 2003). Keating et al. (2000) reported on advances in industrial computed tomography applications.

In 2004, Akers and Rideout discussed a new Photon/Neutron Induced Positron Annihilation method for detecting corrosion and fatigue in bridge structures and cables. This method was developed at the Idaho National Engineering and Environmental Laboratory. According to the authors, positrons, which are anti-particles of electrons, are sensitive to change in a material’s atomic structure. The authors stated that the method can detect damage at the atomic level before overt manifestation of damage. In response to an inquiry, one of the authors indicated that they have not yet performed tests on wire bundles, and hope to conduct research on cables in the future.

Magnetostrictive Sensors

The magnetostrictive sensor (MsS) technology was developed in the early 1990s at the Southwest Research Institute (SwRI) (Bartels et al. 1996). This technology is based on the concept that magnetic fields produce small changes in the physical dimensions of a ferromagnetic material (such as steel), and material strains produce changes in magnetization. Therefore, if the magnetic field around a bar is changed, an elastic wave (guided wave) would be generated, which would travel in both directions along the length of wire. The stress wave would change the magnetic induction of the material, thus generating voltage in the receiving coil, which can be monitored. The transmitting and receiving coils can be identical. This approach is a form of ultrasonic testing. Figure 62 shows the basic MsS concept. This approach was used on the hanger cables of the George Washington Bridge in New York City. Figure 63 shows the trace of the results as well as the attachment of sensors on the hanger.

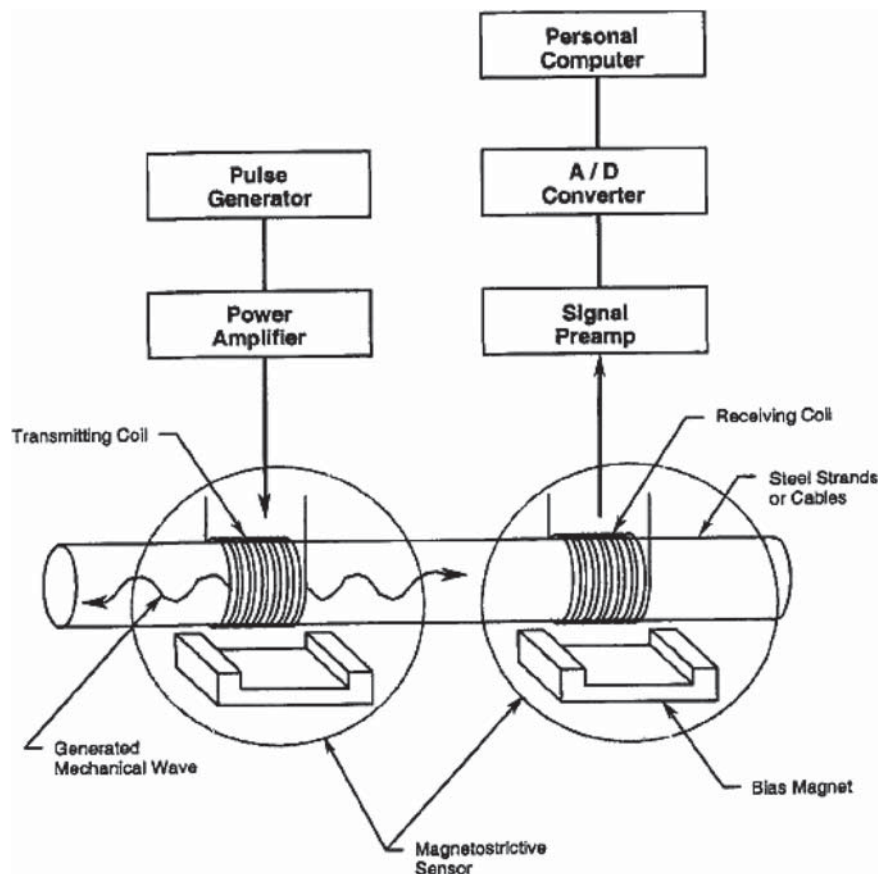
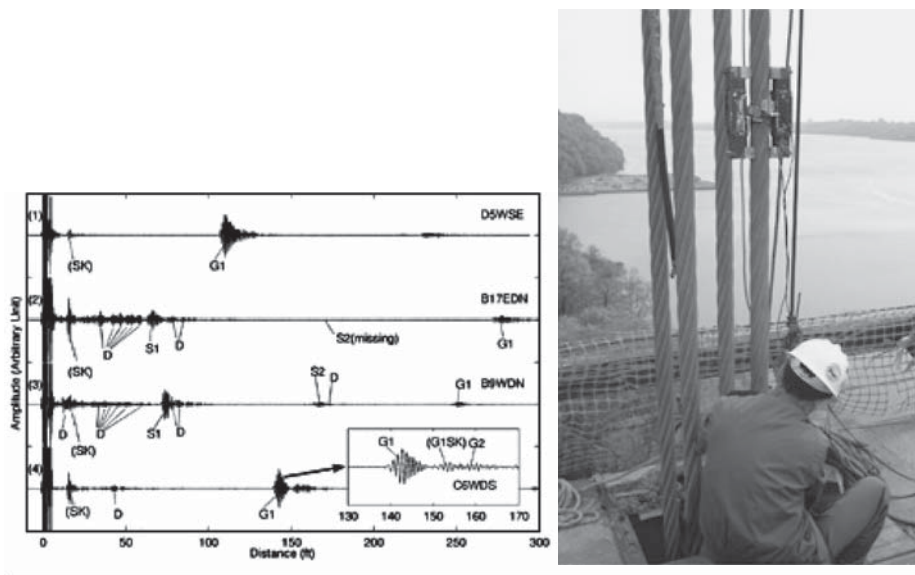

FIGURE 62 Schematic diagram of MsS sensors (Bartels et al. 1996).



MsS technology can effectively inspect the approximately 3-inch-diameter suspenders of the George Washington Bridge. The image above left compares the data collected from four wires in the suspenders on the bridge. "D" represents a defect. "SK" represents a socket and "G" represents a gatherer, both of which are normal components of the suspender. Suspender 1 had been recently replaced, and thus showed a clean signal with no defect indications.

FIGURE 63 Application of MsS technology to inspection of hanger cables (Kwun 2003).

Dr. Hegeon Kwun of SwRI indicated that they have tested anchorage areas of main suspension cables where wires are separated. SwRI researchers believe that the MsS technology can be applied to stay cables; however, they as yet have not had an opportunity to test stay cables. Dr. Kwun believes that, in the anchorage zone, small defects (some broken wires) would likely not be detectable using these guided waves.

Laser Ultrasound

A guided ultrasonic wave for NDT and evaluation can be applied to a test structure (e.g., a strand) in different ways, such as coupled (contact) ultrasonic transducer, MsS, or laser ultrasound. In ultrasonic testing of strands in stay cable anchorages, the ends of seven-wire strands are typically ground smooth to allow perfect coupling with the ultrasonic transducer. However, typically larger transducers that are used cannot be practically coupled to individual wires. The same applies to the MsS technique. However, the laser ultrasound can be applied as a point load anywhere at the end of the strand or wire. It can also be applied eccentrically to generate both longitudinal and flexural modes (Rizzo and Lanza di Scalea 2004). In this article the authors discuss the dispersive and attenuating behavior of guided ultrasonic waves in multi-wire strands. The use of laser ultrasound may potentially offer a way to improve the basic ultrasonic technique for inspection of stay cable anchorage, either on its own or in combination with the MsS technique.

Other Methods

Telang et al. (2004) performed a number of tests on two mock-up stay cable specimens to evaluate various NDT techniques including impulse response, impulse radar, infrared thermography, and radiography. These specimens contained parallel steel wires enclosed within PE sheathing and grouted. The objective was to find methods that could be used to identify deficiencies in PE sheathing (cracking and previously epoxy-repaired cracks), damage to ultraviolet (UV)-resistant wrapping over the sheathing, and grout defects. The sheathing defects were hidden under a UV-resistant wrapping tape. The sheathing was cut in different directions to represent cracks before wrapping. Telang et al. (2004) reported that the impulse response method was found not to be effective. The impulse radar method (involving high-frequency EM energy) was reportedly successful in detecting grout voids or damage. Figure 64 shows a radar survey identifying grout voids.

Telang et al. (2004) summarized their results as shown in Table 8. They suggested that splits in PE sheathing (under the tape) can best be identified with infrared thermography or low-energy X-rays. The authors explained that the thermographic method was not able to discern filled voids or voids in the shade on the bottom of the specimen. In addition, the method was not able to see defects beneath areas with damage to the UV tape. The solar heating of the black pipe in areas where it

was exposed masked any potential defects in the PE. It should be noted that the best results occurred immediately after the specimens were moved from the climate-controlled laboratory to the outside in a warm and sunny environment. This thermal gradient may not be representative to normal environmental heating and cooling except in extreme conditions. It is likely that the effectiveness of the thermography would be limited to early morning or late evening. They also noted that:

The infrared thermography was very effective in detecting unfilled splits in the HDPE under certain environmental conditions. This condition requires sudden variation in the ambient temperature to result in temperature gradient in the cable material. It is believed that to keep the effectiveness of thermography for unfilled split detection, perhaps also for filled split detection, thermography should be combined with heat generation source.

Figure 65 shows a thermographic image from this test series.

Finally, another method that has been discussed in the literature for detection of corrosion in steel cables is Time Domain Reflectometry (TDR). This method has been referred to as “closed-loop” radar (Ciolko and Tabatabai 1999). It has been widely used in identifying problems in transmission lines. The process involves sending a high-frequency signal through the sensing cable and monitoring the reflections. The reflections come about as a result of impedance changes along the length of the cable. There have been a number of research efforts aimed at using strands as sensing wires in the TDR setup. Ciolko and Tabatabai (1999) reported that the results of laboratory and field studies on this method were not encouraging.

Liu et al. (2002) discussed using TDR in a manner slightly different from the earlier studies. In this research, an external wire is used in conjunction with the strand to form the “transmission line” for TDR tests. This method is sensitive to the presence of or variations in moisture. At the present time, the available data do not indicate a potential for successful field applications to stay cables.

LONG-TERM EVALUATION AND MONITORING

This section includes methods that could be used for long-term monitoring and inspections of stay cables.

Acoustic Monitoring

Acoustic monitoring is a passive method for detection of wire breaks in stay cables. It “listens” for shock waves emanating from wire breaks. It is called “passive” because it cannot detect existing wire breaks. It has to be there and be “on” if it is to detect a break.

Acoustic monitoring for stay cables probably began when a method for detecting wire breaks during qualification tests of stay cables was needed. Various test laboratories that performed such tests needed to count the number of wire breaks

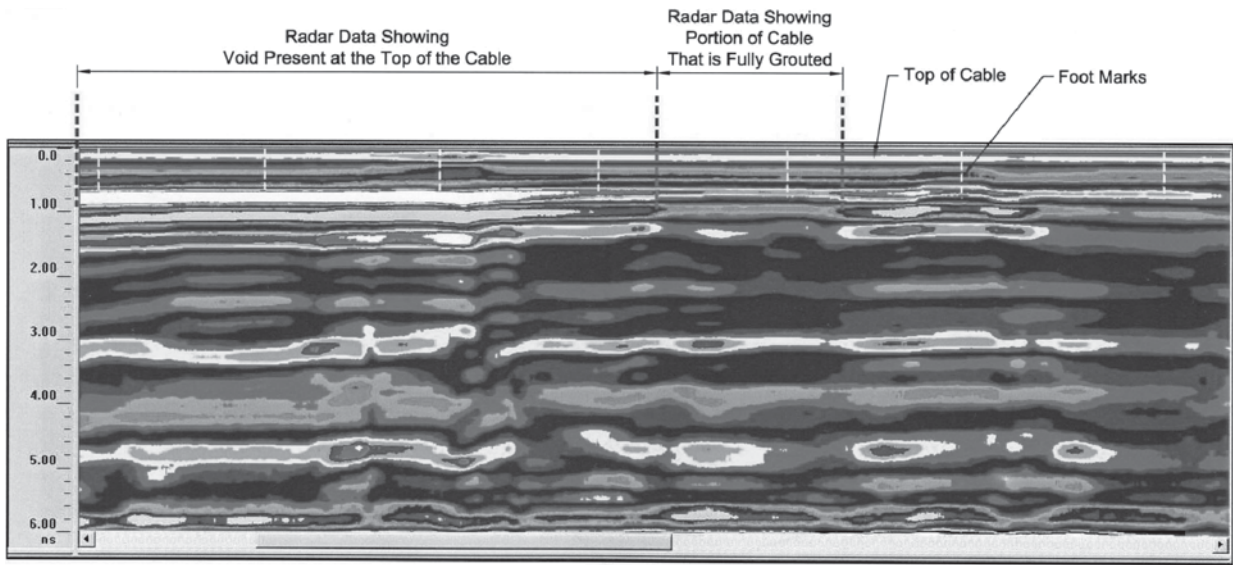

Sample Radar Scan

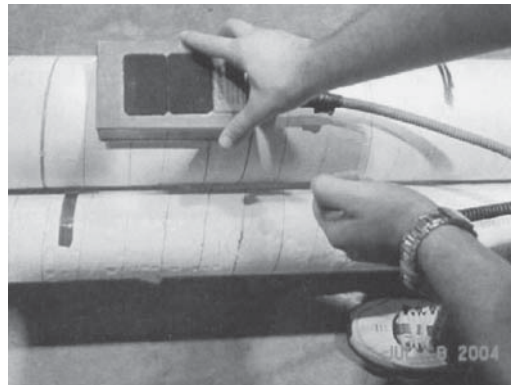

FIGURE 64 Sample impulse radar survey (Telang et al. 2004).

TABLE 8
COMPARISONS OF SOME NDT METHODS FOR DEFECTS IN PE SHEATHING, GROUT,
AND TAPE

NDT Method	Relative Cost	Relative Inspection Rate	Adaptability to Environmental Conditions	Effectiveness			
				Unfilled Split in Sheathing	Epoxy-Filled Split in Sheathing	Damage to UV Tape	Grout Void or Damage
Impulse response	low	high	high	none	none	none	none
Impulse radar	low	medium	high	none	none	none	good
Infrared thermography	low	medium	low	good	none	good	none
Low energy X-ray	high	low	high	good	fair	good	good

Source: Telang et al. (2004).

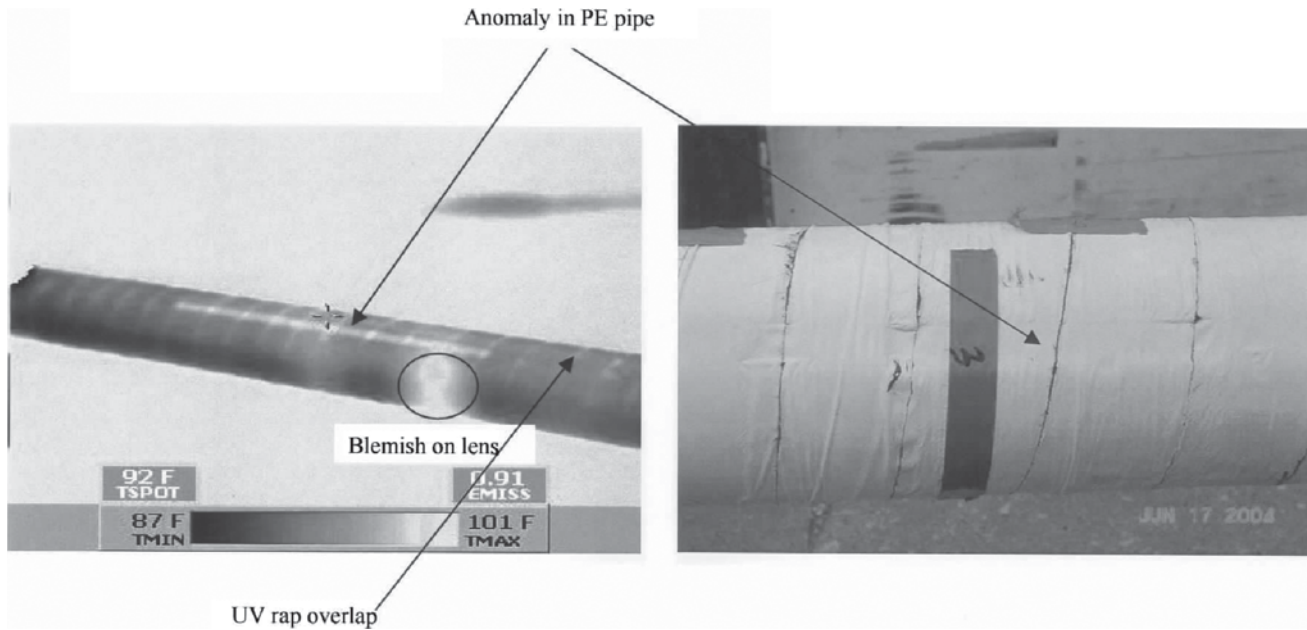

FIGURE 65 Infrared thermography image for detection of HDPE splits under tape (Telang et al. 2004).

during fatigue tests on the cable specimens, and therefore developed their own acoustic monitoring techniques. The basic system essentially consists of accelerometers located at selected points and the anchorages. The location of a break could be determined by comparing the arrival time of the shock wave at different sensors. It should be noted that the attenuation of acoustic waves in grouted cables is much higher than in ungrouted cables.

Tabatabai et al. (1995) performed tests on a one-tenth-scale model of a nuclear containment structure containing unbonded post-tensioning strands. Wires were cut, and the wire breaks were detected by accelerometers.

A commercial acoustic monitoring system based on piezoelectric sensors and proprietary software is available. The system was initially developed for post-tensioned buildings and parking garages, and was then extended to bridges and other structures. According to the company, this system has been installed on the following cable-stayed bridges:

- Fred Hartman Bridge (Texas)—acoustic monitoring system was installed in March 2002 on all 192 cables (grouted seven-wire strands).
- Quincy Bridge (Illinois)—system was installed in June 2002 on 14 of 56 stays (grouted seven-wire strands).
- Seyssel Bridge (France)—system was installed in May 2003 on 4 of 36 stays (grouted seven-wire strands).
- Penang Bridge (Malaysia)—system was installed in December 2003 on 120 of 148 stay cables (grouted bars).

A research program involving the acoustic monitoring system has been in progress at the University of Texas–Austin. On request, Prof. Sharon L. Wood and the research team at

University of Texas–Austin prepared a write-up of the test plan and a summary of their findings based on two Master's theses. The research team's conclusions for the acoustic monitoring system are given here:

[The system] provides an accurate method for monitoring wire breaks due to fatigue damage in grouted stay cables. The system was able to identify the number of wire breaks accurately. The locations of the estimated wire breaks along the free length of the cable were typically within 6 in. of the actual breaks. The accuracy of the system was less near the anchor heads, but the geometry of the specimen is much more complex in this region. The locations of the estimated wire breaks near the ends of the cable tended to be within 18 in. of the actual breaks.

Long-Term Sensor-Based Monitoring

A number of parameters can be measured on stay cables using sensors. In previous sections of this report, examples of long-term vibration monitoring were given. Uniaxial or biaxial accelerometers are generally used for vibration monitoring. Uniaxial accelerometers are used to capture in-plane vibrations. Biaxial accelerometers can measure both in-plane and out-of-plane vibrations. The accelerometers are attached to the cable with suitable clamps or other hardware that could withstand long-term exposure. The positions of the sensors are selected to maximize the desired sensor response for the vibration modes of interest, and considering access limitations. In conjunction with acceleration measurements, weather data are also typically collected including wind speed, direction, rain, and so forth. The sensors are connected to a high-speed data acquisition system at a secure location on the bridge. The system is typically powered with AC (alternating current) power (if available) or solar panels. The system should be designed in such a way as to protect against dam-

age resulting from lightning, vandalism, moisture, extreme heat, and extreme cold. Typically, data transfer to the office can be accomplished through wireless or landline modems. Data can also be stored on-site for manual retrieval.

In addition to vibration measurements, stay cable sensing could also include cable tension measurements through load cells or other force sensors. Bronnimann et al. (1998) reported on the testing of distributed fiber optic strain sensors for stay cables. Continuous (nondiscrete) strain or even acceleration sensing along the length of cable, if practical and reasonable from a cost standpoint, can be important in condition assessments. In such cases, the localized strain changes, or changes in mode shapes indicative of damage, could potentially be determined.

A search of the literature and the survey results did not identify any bridges where moisture or humidity sensing is performed. In the James River Bridge in Richmond, Virginia,

drain holes are placed in the bottom of the area between the guide pipe and the transition pipe near the threaded anchor heads to prevent accumulation of water. Considering that penetration of moisture is an important issue, humidity measurements or moisture sensing inside the guide pipe, anchorage caps, or other cable components could be made in the future.

It appears that in at least two cable-stayed bridges that were in the path of hurricanes, the idea of monitoring cable vibrations with security cameras mounted on the tower, the deck, or on the shores was explored, but it is believed not to have been implemented. There is also no indication as to whether any monitoring of rain–wind vibrations using security cameras has occurred.

In large-scale monitoring systems, an appropriate method for analyzing and interpreting the large amounts of data that are collected must be designed. This has been an important issue in all large-scale monitoring systems.

MAINTENANCE AND REPAIR OF STAY CABLES

REPAIR AND RETROFIT STRATEGIES AND METHODS

The maintenance manuals of 11 bridges were reviewed in this study. There were major differences between the approaches and contents of the different manuals. Although a few manuals included procedures for the repair of cable sheathing and replacement of cables, others did not provide such information. There were major differences as to the level of detail between different manuals, even for the coverage of the same topics. The as-designed and as-built cable forces, deck profile elevations, and others, are typically not included in the manuals and are not required to be measured during inspections. Procedures for checking for moisture and evidence of vibration problems are generally lacking in many maintenance manuals.

The following is a list of the items found in the different manuals that are related to stay cables:

- Bridge description;
- Design considerations;
- Loads;
- Stay cable details: identification numbers, number of strands and wires, diameter of cable, mass per unit length, inclination angles, length, estimated cable tension at the end of construction and after creep and shrinkage effects are taken into account;
- Stay cable shop drawings including as-built anchorage design, materials used, any repairs done during construction, and history of problems during construction;
- Inspection and maintenance frequencies, and qualifications of inspection teams;
- Information on access: platforms, ladders, and snooper trucks;
- Cable retensioning procedures;
- Cable replacement procedures including traffic patterns and specific replacement procedures;
- Inspection procedures for anchorages, guide pipes, neoprene boots, neoprene washers, sheathing, cross cables, dampers, and so forth, including identification of critical areas and how and where to look for moisture and corrosion;
- Listing of designers, contractors, and suppliers of stay cables and components;
- Summary of qualification test results for MTEs;
- Summary of qualification test results for the entire stay cable system;
- Deck elevation surveys;
- Repair procedures including sheathing repair, PVF tape repair, repair of damage to guide pipes, and welded connections;
- Safety and traffic control during inspections;
- Description of methods for measuring cable forces;
- Inspection forms; and
- Deck elevation survey forms.

The examination of the maintenance manuals did not identify cases where any of the following methods discussed in the literature were included in the manuals:

- Recommendations for baseline measurements of cable frequency, damping ratio, cable sag, and cable inclination angles (at specific points accessible by inspectors). Such measurements can be taken when the effects of creep and shrinkage have dissipated. Such measurements could also include air and structure temperatures.
- The designer's estimated (calculated) cable frequencies, sag, and inclination angles (at a specific point) with and without the effects of cross cables or dampers (if used). This information could be provided for different ambient temperatures.
- The designer's estimated (calculated) bending stiffness and damping of cable in the free length and in the anchorage zones.
- The designer's estimated (calculated) stiffness of neoprene rings and/or proprietary dampers in contact with the cable.
- Procedures for checking if viscous or other dampers are actually working as intended including maintenance procedures for dampers.
- The designer's estimated (calculated) wind speeds at which vibrations owing to vortex shedding would be expected.
- The designer's calculated values of the "precursor transformation matrix." This matrix would be required if the damage detection methodology, Precursor Transformation Method (Tabatabai et al. 1998b), is employed in the future. This method uses a linearly elastic finite-element model of the bridge. In the computer model, the temperature of the cables are, one by one, raised by say 100 degrees, and the force changes in all other cables are noted. Each column in the transformation matrix would consist of cable force changes associated with tempera-

ture increase in a particular cable. Temperature increases are meant to represent loss of stiffness of individual cables without the need to modify the cable stiffness. Future measured cable force changes can then be used together with the transformation matrix to identify cables that have suffered stiffness losses. A similar transformation matrix can be formed that is related to deck elevations instead of cable forces. Other sources of damage, such as support settlements, can also be incorporated.

There are very few components of the common stay cables (i.e., those that have been designed over the last 30 years) that could be considered repairable. Practically, the only items that the inspectors and maintenance engineers can realistically repair are the HDPE cable sheathings, neoprene boots, and possibly the elastomeric rings. Retrofitting for vibration control can also be done. However, repair of corrosion or fatigue damage to MTEs in the free length or anchorages of older cables (not the newer designs) is practically impossible, short of removal of the entire cable. The removal process itself is a major challenge and a significant undertaking, especially on older bridges. The main task of the maintenance engineer and inspectors is therefore prevention, especially control of moisture (from internal and external sources) and elimination of excessive vibrations. If preventive measures fail, the maintenance engineer must then have a reliable tool to determine if a cable or cables must be replaced and when they should be replaced.

A number of options are available with regard to repair of damaged or cracked HDPE sheathing. For minor localized damage, conventional wrapping with PVF tape is typically done, although this is believed by some not to be effective. When the HDPE has cracked or has more widespread damage, then a more extensive repair must be considered. The options include an elastomeric wrap system and a two-piece HDPE pipe that snaps together to form a cover for the original pipe. The elastomeric wrap is installed with an automatic wrapping device with 50% overlap. Within 24 h after wrapping, the wrap is heated to fuse the seams and shrink the wrap against the cable. The ends of the wrap must be secured firmly to prevent lifting.

The maintenance manual for the James River Bridge in Virginia included procedures for the repair of longitudinal splits in PE sheathing. This involves removal of the existing film tape, cleaning of the damaged area at least 3 ft above and below the split, filling of the crack with a suitable polyurethane grout or other compatible material to obtain a smooth surface, using 8 mil polyester film tape with fiberglass reinforcement to wrap the cable from 2 ft below to 2 ft above the split with minimum of 50% overlap, and wrapping again with PVF film.

The available choices for the repair of steel sheathings are far more limited, and there is no known track record for the effectiveness of such repairs. A report prepared for the Delaware DOT recommends application of flexible liquid mastic to the cracks on a steel saddle pipe and continual inspections.

Figure 66 shows the results of the survey as related to the repair of stay cables. Approximately 30% of cables in the United States and Canada have had some form of repair.

MITIGATION OF STAY CABLE VIBRATIONS

A wide variety of solutions to the problem of stay cable vibrations have been proposed and/or implemented. These mitigation approaches can be categorized as modifications to the surface of HDPE pipe, cross cables, viscous dampers, viscoelastic dampers, friction dampers, tuned mass dampers, semi-active and active dampers, and others. In this section, a brief summary of each approach is given.

Modifications to the Surface of HDPE Pipes

As discussed earlier, the formation of rivulets on the surface of the cable is believed to be the cause of rain-wind vibrations. Therefore, a very popular and effective approach has been to modify the surface of the cable to break up and disrupt the flow of water, thus not allowing the formation of rivulets. A very common form of this modification is helical or spiral marks, fillets, or ribs on the surface of HDPE pipe as shown in Figure 67. Figure 68 provides wind tunnel results with and

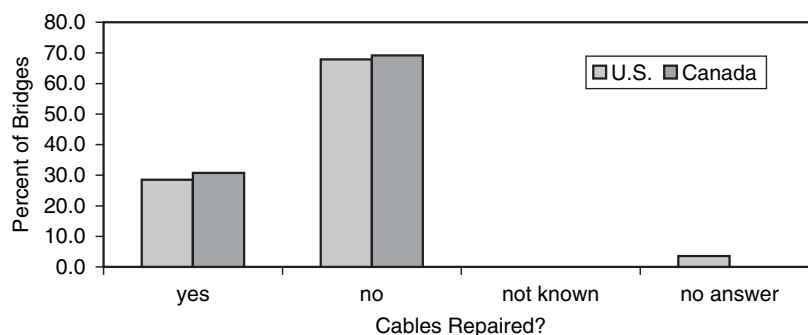

FIGURE 66 Percentage of bridges that have had cables repaired.

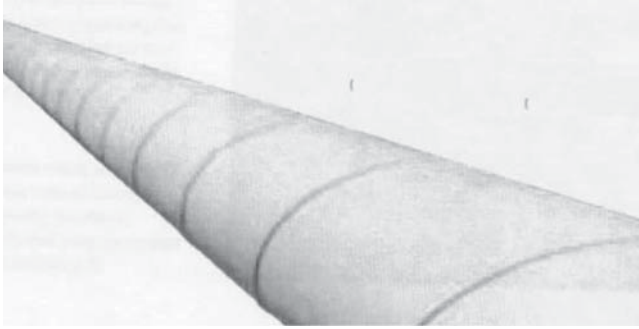

FIGURE 67 Spiral strakes on the surface of HDPE pipe to control rain–wind vibrations.

without surface modifications. According to the wind tunnel tests by Larose and Wagner Smitt (1999), in some cases, the rain–wind vibrations persisted with limited amplitudes even with the helical fillets.

Other, less frequently used options are dimples or longitudinal ribs on the surface (Figure 69). Surface dimples were used on the Tatara Bridge in Japan, and Yamaguchi et al. (1999) reported that they were effective in controlling rain–wind vibrations.

Cross Cables

Cross cables, secondary cables, cable restrainers, or cross ties are used to connect different stay cables within a cable plane. Figure 70 shows a cross cable installed on SR-46 over the East Fork White River in Indiana.

These transverse connections reduce the effective length of the cable and increase cable frequency (Ito 1999). They also somewhat increase cable damping (Lankin et al. 2000). Yamaguchi and Nagahawatta (1995) performed experimental and analytical research on the damping effects of cable cross ties. The experiments consisted of two cables connected with two cross ties. They concluded that “there exists a more or less

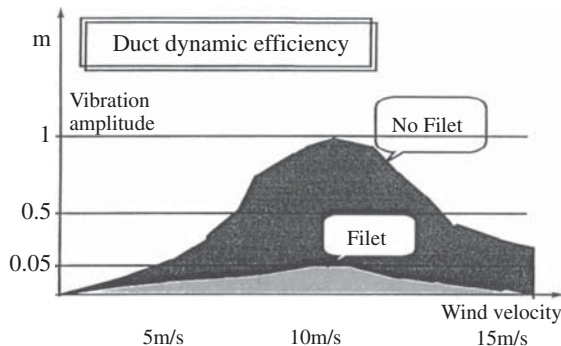

FIGURE 68 Effect of surface modifications on vibration amplitudes (Stubler 1999).

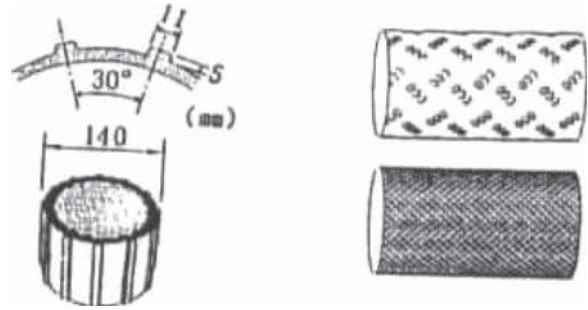

FIGURE 69 Surface modifications on the HDPE (Matsumoto 2000).

damping effect” from cross ties, which can be increased by using more flexible and dissipative ties.

Cable restrainers have also been used as a temporary solution to rain–wind vibrations (Poston 2002). Figure 71a shows the restrainer system with three lines of cables, and Figures 71b and c, respectively, show the measured vibration amplitudes before and after installation of restrainers.

During the construction of the Burlington Bridge over the Mississippi in Iowa, several incidences of rain–wind vibrations were observed with amplitudes of up to 0.6 m (2 ft) (Bierwagen no date). Bierwagen reports that temporary ropes in the form of 25-mm or 1-in.-diameter Manila ropes were first used to help tie the cables down. However, the Manila rope broke during a subsequent occurrence of vibrations. There-

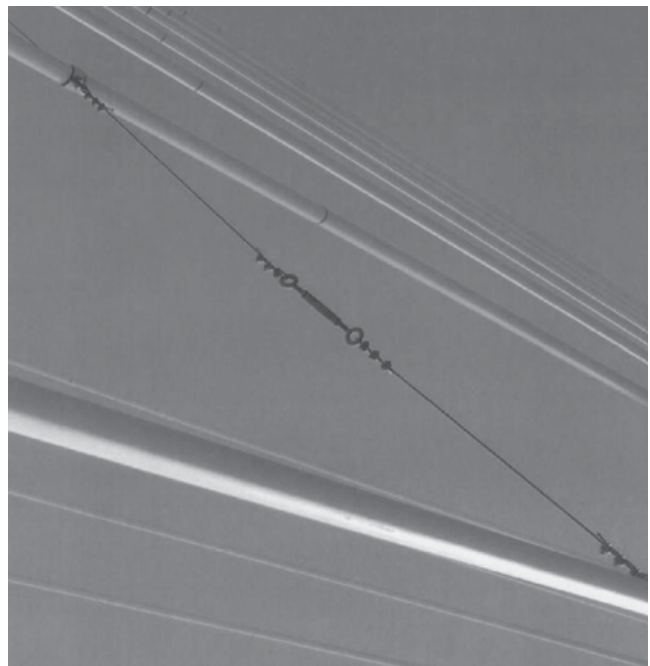

FIGURE 70 Cross cable installed on a bridge in Indiana (courtesy: Indiana DOT).

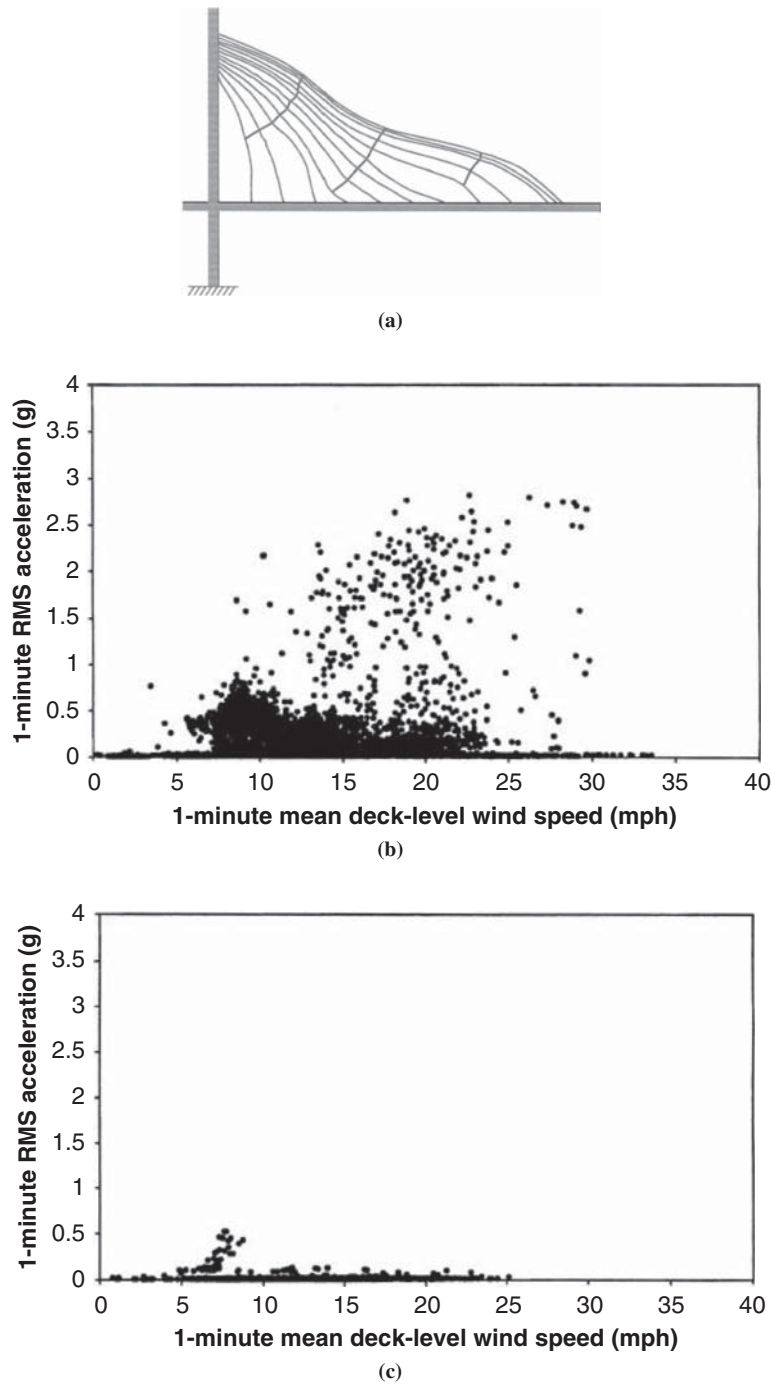

FIGURE 71 (a) Cable restrainer, (b) vibrations before installation of cross cables, (c) vibrations after installation of restrainers (Poston 2002).

fore, a cross cable system was designed and implemented. Figure 72 shows the layout of cross cables (*top*) and the method of connection to the cables (*bottom*). According to Bierwagen, the restraint system included 12.6-mm or 0.5-in.-diameter zinc-coated wire ropes that crisscross through the cables and are attached to them using friction clamps. Similar cross cables have also been used on the Clark Bridge in Alton, Illinois.

It is reported that the cross cables should be tensioned properly to prevent slacking of the restrainers (Bourmand 1999). Bourmand reported that the cross cables on the Fred Hartman Bridge in Texas failed one year after installation as a result of fatigue and fretting. He suggests that “the cables must be designed using a flexible wire rope or similar system (with high internal damping) and with good fatigue and wear resistance.” This system was installed on the bridge. Some observers also

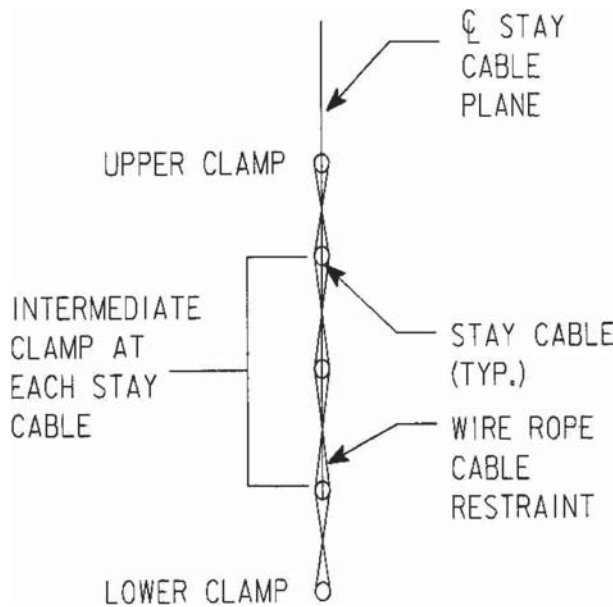
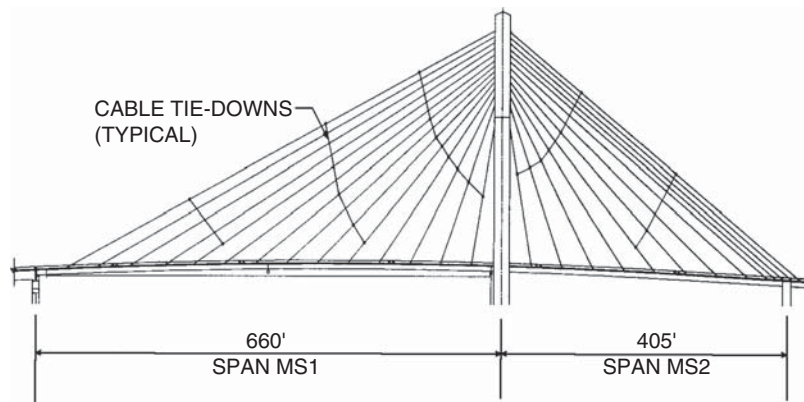

FIGURE 72 Cable restraint system for the Burlington Bridge in Iowa (Bierwagen no date).

believe that cross cables reduce the aesthetic quality of cable-stayed bridges (Johnson et al. 2002).

Bloomstine and Stoltzner (1999) reported on the failure of a wire cross cable on the Faroe cable-stayed bridge in Denmark. The original system consisted of steel brackets with neoprene linings attached to the cables with stainless steel wire connected in between them. The wires “were wrapped around a thick washer in the bracket and secured by two wire locks.” Abrasion between wire and the washer caused the first wire failure after 4 years. A new system using 10-mm marine grade stainless steel wire and turnbuckles was used.

Many respondents to the survey had positive views concerning cross cables, with the ability to inspect them and know whether they are working given as an important factor. Figure 73 shows the results of the survey as related to the use of cross cables.

Viscous Dampers

In this section, the application of mechanical viscous dampers for suppression of stay cable vibrations is discussed. In general, the term “viscous damper” used here refers to a mechanical damper that generates force proportional to the velocity of piston movements (i.e., it can be idealized as a dashpot). Other investigators sometimes prefer to use the terms “oil damper” or “hydraulic damper,” and distinguish them from viscous damper. In this discussion, they are all referred to as viscous damper as long as they meet the definition given.

Viscous dampers for stay cables have been installed on a large number of cable-stayed bridges worldwide, including the Sunshine Skyway Bridge, Cochrane Bridge, and Erasmus Bridge. Figure 74 shows a schematic of a cable of length L , with a viscous damper positioned at a distance of L_d from one end.

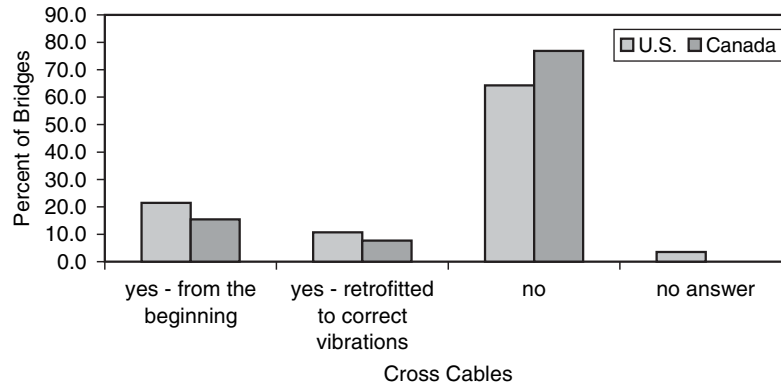

FIGURE 73 Frequency of the use of cross cables.

Several researchers have proposed numerical approaches for determining the contribution of a viscous damper to the overall cable damping. Some of the earlier works were by Kovacs (1982), Yoneda and Maeda (1989), and Pacheco et al. (1993). Each idealized the cable as a taut string when deriving their formulations. In 1999, Xu et al. presented results of their experimental study on control of cable vibrations using viscous dampers.

Tabatabai and Mehrabi (2000) presented a nondimensional formulation that included the effects of cable sag and bending stiffness, and performed parametric studies (using cable parameter ranges from a database of stay cables) to develop an equation for calculating the first mode damping contribution by a viscous damper. This study indicated that the influence of cable sag was insignificant for the range of parameters found in stay cables. However, the influence of cable bending stiffness was found to be important, as dampers are typically located close to the anchorages. Although their formulation was applicable to higher modes as well, their proposed equation was optimized for the first mode only.

Main and Jones (2002) investigated the multi-mode contribution of a linear viscous damper attached to a taut string. They pointed out that damper performance at higher modes is

of particular interest, because vibrations occur over a wide range of cable modes. The influences of sag and bending stiffness were ignored.

Main and Jones (2001) discussed the installation of two viscous dampers on the Fred Hartman Bridge in Texas. They analyzed the pre- and post-damper installation response of the cables, and showed that although the dampers were designed for the first mode, they were very effective in controlling all of the high-amplitude vibrations that had been observed before damper installation.

There is a rough “rule-of-thumb” that can be used to estimate the maximum achievable damping (in fraction of critical damping). The maximum damping is approximated as $0.5(L_d/L)$ (Lankin et al. 2000). Therefore, if a damper is located at 2% of the length of the cable, then the maximum achievable damping is 1%. It is important to realize that the theoretical end of the cable from which L_d is calculated is generally different from the actual end. The complicating factors are the varying bending stiffness of the cable at the end, the presence of neoprene dampers, and the presence of steel sockets. Tabatabai et al. (1998b) presented approximate relationships that allow determination of an equivalent effective length for different end conditions.

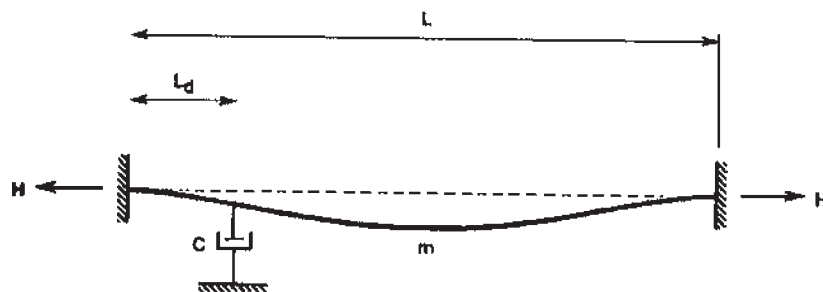

FIGURE 74 Idealized cable with viscous damper (Tabatabai and Mehrabi 2000).

The respondents to the questionnaire indicated seven bridges with viscous dampers, most of which were installed to correct observed vibrations. There is some concern expected about potential leakage of fluids in such dampers.

Viscoelastic Dampers

The commonly used neoprene ring can essentially serve as a viscoelastic damper; however, because of difficulty with consistent installation and their variability, their level of damping contribution is difficult to estimate. Tabatabai and Mehrabi (2000) performed tests on a scale stay cable model with and without neoprene rings. The neoprene rings increased damping by more than 10-fold to 0.6% of critical damping.

There is at least one cable supplier that is supplying proprietary viscoelastic and hydraulic damping systems. These systems are placed between the HDPE and the guide pipe (or an extension of guide pipe). The viscoelastic damper uses a shaped elastomeric material to damp cable vibrations (Figure 75). It is expected that most suppliers would have their own damping systems in the near future.

Another form of viscoelastic damper is the Super High-Damping Rubber Damper (SDR). Mizoe et al. (1999) presented a damping device that is installed between the cable and the guide pipe (or anchor pipe). When the cable moves, a relative displacement occurs between the cable and the guide pipe causing shear deformations in the damping material. A high-damping material is developed by combining styrene butadiene rubber, high-damping carbon, and some plastics to achieve its properties. Figure 76 shows the SDR damper. These dampers were first installed on two cables of the Meiko East Bridge in Japan for testing. The authors reported that the damping level achieved was confirmed with calculated values. Subsequently, these dampers were installed on most cables of this bridge. They have been in service since 1998, and wind-induced vibrations have reportedly not been observed.

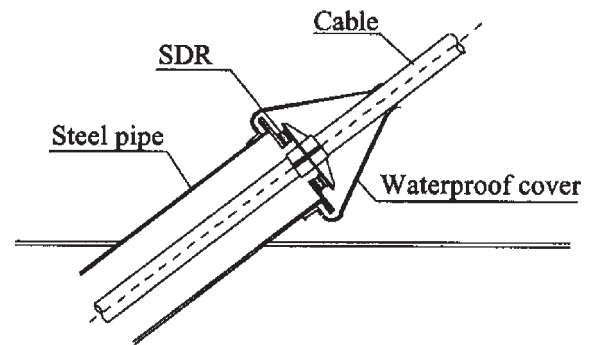

FIGURE 76 SDR damper (Mizoe et al. 1999).

Friction Dampers

Bourmand (1999) reported on the development of a friction damper for stay cables (see Figure 77). This damper system has two parts; a movable part that is attached to the strands by a bolted collar and a fixed part that is bolted to the steel support pipe. The bolted collar has several “friction wings,” and the fixed part has several “spring ring blades supporting several friction screws.” The ring blades are deflected to have a steady friction contact of the friction screws. This damper type has reportedly been installed on the Uddevalla Bridge in Sweden.

Semi-Active Dampers

Johnson et al. (2002) presented a theoretical discussion and described the development of semi-active damping for stay cables. A semi-active damper can be a variable-orifice viscous damper, a controllable friction damper, or a controllable fluid damper (Johnson et al. 2000). Computational simulations were used to examine the effectiveness of semi-active damping. The authors reported that the potential for using semi-active dampers to control stay cable vibrations “has been demonstrated” in comparison with passive viscous dampers.

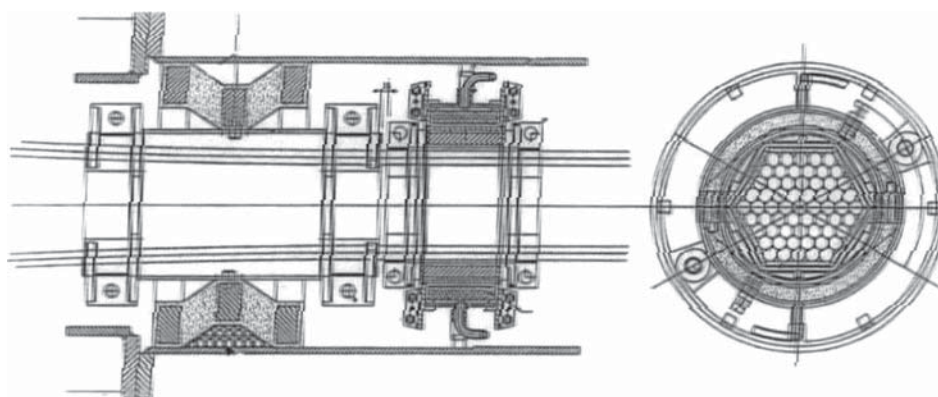

FIGURE 75 Viscoelastic and hydraulic dampers (Stubler et al. 1999).

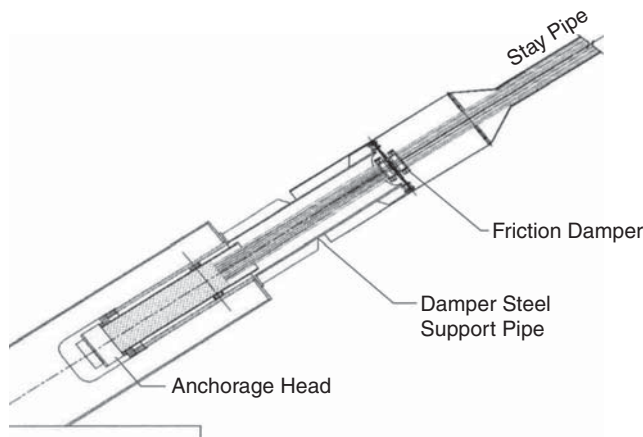

FIGURE 77 Friction damper (Bournand 1999).

Using an optimal control algorithm, the authors stated that a simulated semi-active damper located at 2% of the distance from the end of cable reduced responses by 71% compared with an optimal viscous damper and 72% compared with fully active devices.

Johnson et al. (2000) reported on laboratory experiments on scaled stay cables with a magnetorheological (MR) fluid damper. MR dampers are a type of semi-active damper (controllable fluid) in which the yield stress of the fluid is changeable through variations in magnetic field strength. Laboratory results indicated that the damper was able to achieve “significant” response reductions, but not to the level expected from simulations. Recommendations were made for addressing this problem in future studies.

Ko et al. (2002) reported on field tests of stay cables with MR dampers on the Dongting Lake Bridge in China. Field measurements were taken before and after damper installations. The equivalent damping level was found to be dependent on damper location, voltage applied to damper, and the level of vibration. Under optimum voltage input, the damping ratios for the second and third modes can reportedly be greater than 0.8% of critical damping. These semi-active dampers are commercially available. Figure 78 shows MR damper installation on a bridge cable in China.

Tuned Mass Dampers

The tuned mass damper (TMD) is tuned to a particular frequency of interest; for example, the first mode of the cable. The TMD, in its basic mathematical representation, consists of a mass, a spring, and a damping component. By changing the basic properties of the damper, the TMD can be tuned to the right frequency. TMDs have been applied to a variety of structures including power line cables. Tabatabai and Mehrabi (1999) patented a shaped viscoelastic TMD for stay cables.

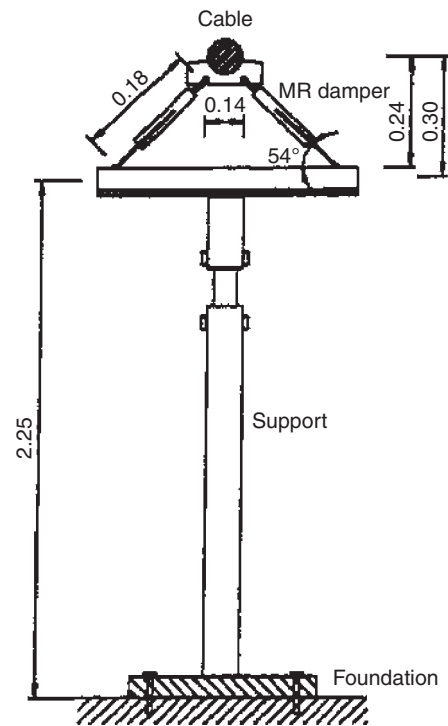

FIGURE 78 MR damper installation on bridge cable in China (Ko et al. 2002).

The main advantage of the TMD is that it is not restricted to the cable ends. The main disadvantage is that it can only be tuned to a particular frequency, and its effectiveness is reduced at other frequencies.

Jensen et al. (2002) proposed using a TMD between two cables at mid-length. In their article, the authors present an analytical formulation for their concept.

Other Damping Systems

Tabatabai and Mehrabi (2000) reported on damping tests on a scale model of a stay cable. They tested a number of approaches for cable damping including using common neoprene rings, latex grout as filler inside HDPE, a liquid damper, application of spiral adhesive damping tapes around HDPE, and filling of the guide pipes with a low stiffness polyurethane. They concluded that the conventionally used neoprene ring improved cable damping significantly to 0.4% to 0.6% of critical damping (compared with a damping of 0.05% for cable without neoprene ring). They suggested that the effectiveness of neoprene rings is influenced by the degree of precompression in the neoprene ring and any restraint of ring movement in the transverse direction. The use of latex grout increased cable damping by 60%, but not to the level needed for control of rain-wind vibrations. They also concluded that the liquid damper and damping tapes did not significantly improve damping. Filling of guide pipes

around HDPE with polyurethane improved cable damping somewhat, but not to the level achieved by a properly installed neoprene ring. The authors suggested experimenting with higher stiffness polyurethanes as a possible effective approach. It is interesting to note however that Yamaguchi et al. (1999) reported that filling “rubber seals into the entrance of cable in the girder” in some cables of the Tatara Bridge in Japan reduced incidences of vortex-induced vibrations, and they consider this to be an efficient solution for long cables.

There are a number of other patented concepts for damping stay cable vibrations including flexible damper bands by Sarkar et al. (2002) and two separate patents on active damper bands with shiftable mass by Phelan et al. (2002, 2004).

CHALLENGES IN MAINTENANCE, REPAIR, AND RETROFIT

The main challenges in maintenance and repair are:

- Determining the condition of the anchorage elements, especially those that include cement grout or epoxy fillers, at reasonable cost and with reasonable confidence.
- Proper and safe access for inspection of cables.
- Methods and procedures to replace existing cables on a number of aging bridges, when needed.
- Control and elimination of moisture and corrosion inside cable components.
- Vibration control and fatigue issues associated with vibrations.
- Insufficient sharing of knowledge and training for those responsible for maintaining cable-stayed bridges.

CHAPTER FIVE

FUTURE TRENDS

It is anticipated that several of the following trends will dominate the design, construction, and maintenance of stay cables in the next 2 to 5 years. Some of these trends have already taken hold.

- Stay cable systems supplied by U.S. manufacturers will finally converge and settle (at least for a time) on a system composed of wedge anchorages, greased-and-sheathed strands (possibly galvanized), and co-extruded HDPE pipe with helical strakes on the surface. Grout will likely not be used in many cases. Strands will be changeable, at least in theory. Issues related to performance of anchorages during earthquakes may force a reconsideration of wedge systems in seismically active areas.
- Stay cable manufacturers will include additional features and options on their stay systems such as strand force measurements, damper systems that are contained within the guide pipe or in the vicinity of guide pipes, removable test strands, and visible or inspectable anchorages and MTEs.
- Video monitoring systems for cable vibrations may become available and widely used.
- More tools and procedures that would allow inspectors to improve the effectiveness of visual surveys will become available.
- Built-in damage monitoring systems may be developed for the anchorage zones (based on magnetic method or guided stress waves), perhaps included as an option on supplier's systems.
- Methods that will likely become common for nondestructive evaluation of existing grouted/ungrouted cables are acoustic monitoring, vibration-based force measurements, ultrasonic testing of anchorages, impulse radar surveys, infrared thermography, and magnetic methods for assessing conditions in the free length of cable. Radiographic methods will also have their place; however, safety and cost issues continue to limit their usage.
- Global sensor-based cable damage detection algorithms will be further developed and begin to be used.

CONCLUSIONS AND FUTURE RESEARCH NEEDS

For this synthesis effort, a worldwide search was undertaken for information on the inspection, repair, testing, and design of stay cable. On-line sources of information as well as engineering databases were examined. A number of knowledgeable individuals were contacted for additional information. A questionnaire was distributed among all state departments of transportation in the United States and provincial departments of transportation in Canada. Based on this information, various methods, approaches, and practices have been explained in detail and their strengths and weaknesses identified. Specific inspection and repair approaches are presented and discussed.

The challenges in inspection and maintenance of cable-stayed bridges are substantial. Those who are tasked with

inspection and maintenance of stay cables confront challenges for which proven and accepted methodologies and tools are limited and, in many cases, very costly. The main tension elements (MTEs) within a cable bundle are, in most cases, hidden from the view of inspectors. Access to cables for visual inspections or nondestructive testing (NDT) is often difficult and, in the case of the anchorage zones, almost impossible.

At the time of this study there were 36 cable-stayed bridges in the United States and 16 in Canada. As of 2005, the average age of such bridges in the United States was 11.4 years. As these bridges become older, the need for effective inspection and maintenance methods and tools becomes more important. Because no one method is sufficient, a combination of methods is necessary.

The following table lists some of the issues involved in the inspection, maintenance, and repair of stay cables. Methods identified in the literature to address those issues and their known advantages and disadvantages, as well as other factors are discussed.

Issue	Method	Comments
General inspections	Visual	Visual inspections are, in most cases, the only method used for cable-stayed bridges. These inspections typically include surveys of the exterior surfaces of cables, exposed surfaces of the anchorages, cross cables and their connections (if available), dampers (if available), and conditions of neoprene boots and guide pipes. However, inspections of neoprene rings inside guide pipes are also done in some inspections. Boroscopes or videoscopes can be used to check the exterior condition of the cable and presence of moisture inside the guide pipe. Anchorage caps can sometimes be removed to check the condition of wedges or button heads. Visual inspections could potentially involve measurements of cable sag and the inclination angle by the inspector from the deck level using simple photogrammetric or optical devices.
Assessment of MTE condition in free length	Magnetic flux leakage	This system has a long history in the inspection of industrial cables and ropes. Systems that can travel along the stay cable are commercially available. This method does not work well with cables that have steel sheathing. The cable size cannot be too large in diameter. Depending on the size of the magnet or electromagnet used, the range of detection would be limited to a thickness around the perimeter. The system can identify the extent of damage and its location along the length of cable, but cannot identify location of damage within the cross section. In its current state of development, this method cannot be used for inspections in the anchorage zones and in the vicinity of the anchorage zones. Unfortunately, those are the areas where most serious problems have occurred.
Assessment of MTE condition	Cable force measurements	This approach is the most widely used, and sometimes misunderstood, nondestructive evaluation (NDE) method. Measurement of cable forces (through the methods described) can help determine if global stiffness changes have occurred in cables. Methods such as the Precursor Transformation Method (discussed in chapter four) can then be used to identify which cables are affected. However, damage in the form of MTE section loss does not necessarily translate into global stiffness change. This is particularly true in grouted cables, where a broken wire can redevelop its stress a short distance away. Therefore, when cable forces in a grouted cable array do not change over time, it cannot necessarily be concluded that there is no loss of MTE.
Assessment of MTE condition	Ultrasonic testing)	This method has been used on a few bridges to evaluate the condition of MTEs in Hi-Am-type anchorages. A stress wave is sent into the exposed end of a wire or strand at the anchorage and the results are displayed. There has been no been systematic and controlled evaluation of this method to determine its degree of effectiveness for stay cable anchorages. Therefore, ultrasonic

Issue	Method	Comments
		tests on cable anchorages for any bridge should ideally first be calibrated with a mock-up of the same anchorage with known defects. Seven-wire strands pose a larger challenge than individual wires because of the complexities of transmission of stress waves in them. The operator must be highly qualified in such tests, because the judgment of the operator is crucial, and the answers in many cases would not be clearly evident. Problems arise owing to the anchorage materials surrounding the MTEs. The stress wave attenuates significantly in a wire embedded in grout or epoxy compared with a wire in air. This method is not applied to the MTEs in the free length of cable. Unfortunately, this is the only known and practical test that is currently available for the assessment of MTEs in the anchorage zones of typical U.S. stay cables.
Assessment of MTE condition	Radiography	Theoretically, this method has the potential to successfully assess conditions of cable anchorages where access to the perimeter can be achieved. This method was used on the anchorages of the Meridian Bridge in California. However, safety issues, cost, and the typically large and heavy equipment have significantly limited their use.
Detection of wire breaks as they happen	Acoustic monitoring	The test laboratories performing qualification fatigue tests of stay cables have long used this method to detect wire breaks in the cable specimens as they happen. As a wire breaks, a stress wave travels along the length of the cable in both directions. Accelerometers attached at the anchorage can detect the event and determine its location along the cable. The recorded response or "signature" can be analyzed to determine if the event is actually a wire break. A commercial system is currently available and has been installed on a number of bridges. This system has proprietary software to identify wire breaks. In grouted cables, the attenuation of the wave is significantly higher than in the ungrouted cables.
Detection of grout voids inside high-density polyethylene pipe (HDPE) sheathing	Impulse radar	Hand-held impulse radar equipment can be placed over the cable and moved longitudinally to identify potential grout voids inside the cable sheathing. This method has been tested on mock-up specimens involving HDPE sheathing. A field application of this method is planned.
Repair of large grout voids	Vacuum grouting	This method has long been used in post-tensioning tendon applications. A vacuum is used to ensure that the grout would fill all the voids in the affected area. Specialty post-tensioning contractors can perform these tasks.
Cable force measurements	Vibration-based using laser vibrometer	In this method, a laser vibrometer is used to measure small vibrations of the cable from a large distance. No special targets need to be placed on the cable. A low-power laser beam (class 2 laser) is used. The measured response is then used to determine the frequencies of vibration. The measured frequencies are then used to calculate force. One should note that to improve accuracy the effects of bending stiffness, neoprene rings, and socket stiffness changes should be considered. When cross cables or dampers are used, the calculation process becomes more difficult. Using an accelerometer in lieu of a laser vibrometer is expected to provide similarly accurate results. However, in some cases, the laser vibrometer could speed up the measurement process.
Cable force measurements	Vibration-based using accelerometer	Similar to the laser-based method described previously.
Cable force measurements	Based on measurement of cable sag	Although the tension in a cable is related to the square of the fundamental frequency, it is also inversely proportional to the cable sag. Therefore, measurements of the cable sag can also be used to estimate cable tension. It is expected that the cable sag could be measured by inspectors from the deck level using simple photogrammetric or optical methods. This approach has apparently not yet been used for inspections; however, contractors have reportedly used it during construction.
Detection of hidden splits in HDPE	Infrared thermography	Hand-held infrared thermography equipment can be used to detect splits in HDPE pipes that are hidden under the protective tape. This method has been tested on mock-up specimens involving HDPE sheathing. A field application of this method is planned. However, tests indicated potential problems in using ambient temperature changes to monitor such defects. The test report suggested that external thermal applications may be required.
Detection of damage to poly-vinyl fluoride tape	Infrared thermography	Similar to the method discussed previously.
Assessment of cable vibrations	Long-term monitoring using accelerometers	When cable vibration problems are suspected, sensors (accelerometers) can be mounted on select cables to monitor vibrations over a period of several weeks, months, or years. Typically, a weather station is also installed on the bridge to obtain local wind and rain information. The data are collected through a high-speed data acquisition system, and typically transmitted to the engineer by means of conventional or wireless communications. The vibration amplitudes and associated frequencies are then studied in conjunction with rain and wind data to assess vibration conditions.

(continued)

Issue	Method	Comments
Assessment of cable vibrations	Video cameras on bridge	There are no known instances of using video cameras to monitor vibrations on cable-stayed bridges. However, this option was discussed for two bridges in the path of hurricanes, but was not implemented. There is research (discussed in chapter three) on using photogrammetric techniques to measure structural vibrations.
Assessment of cable damping	Vibration decay method	There are different approaches to measuring cable damping. In one, an accelerometer is first attached on the cable. Then, a rope is placed around the cable and around an individual standing on the deck next to the cable. The individual pushes back on the rope in a rhythmic fashion trying to match the frequency of the cable. At the same time, the individual would pull the rope higher along the cable. When the cable achieves sufficiently high-vibration amplitudes, the cable is allowed to slow down while the accelerometer is monitored. The time it takes to decay the signal is used to calculate the damping ratio.

There is no single method that would answer all of the questions regarding the condition of stay cables. In most cases, it is the combination of NDT techniques together with the experience, knowledge, and judgment of engineers, inspectors, and technicians that can possibly lead to the appropriate answer. The effectiveness and accuracy of many of the methods described here would be significantly enhanced if baseline comparative measurements were available when the bridge is known to be defect free.

Based on the results of this effort, it is recommended that the following research be undertaken:

- Consider the possibility of establishing minimum requirements for the information that must be included in the inspection and maintenance manuals for cable-stayed bridges. A list of possible topics is included in this report.
- Study the strengths and limitations of ultrasonic testing of MTEs in various types of anchorages.
- Study the effectiveness of visual inspection techniques, and the development of visually inspectable stay cable systems.
- Review the feasibility of built-in or remote inspection and imaging systems for the monitoring of MTE conditions in the cables (especially anchorages) for incorporation into new cable designs.
- Undertake the identification of the appropriate choice and use of combinations of NDE methods based on the conditions at hand.
- Study the feasibility of global, three-dimensional, physical mapping of stay cables and the entire cable-stayed bridge.
- Study the development of safe and effective cable inspection vehicles that can travel along cable length and carry NDE test hardware. It may be possible that different states with similar cable systems can share the equipment.
- Undertake the development of a national resource for information on stay cables and cable-stayed bridges to assist bridge owners and others with information on inspections, maintenance, and testing of stay cables; new trends and methods; and a statistical database of cable information. Creation of a database of information on stay cables was strongly supported (90%) by the respondents to the questionnaire.
- Study the development of national or regional periodic training programs for state engineers and inspectors responsible for cable-stayed bridges to learn about new developments and to share their experiences.

REFERENCES

- Aas-Jakobsen, K., E. Jordet, and S.K. Rambjør, "Full-Scale Measurements of the Behavior of the Helgeland Bridge, A Cable Stayed Bridge Located in a Harsh Environment" [Online]. Available: http://www.aas-jakobsen.no/Bridges/Publications/Helgeland_Bridge/full_scale_measurements.
- Akers, D.W. and C.A. Rideout, "Innovative Nondestructive Inspection Technology for Quantifying Deterioration in Bridge Structures and Cables Using Induced Positron Annihilation Technologies," *Proceedings of Structural Materials Technology (SMT): NDE/NDT for Highways and Bridges*, Buffalo, N.Y., Sep. 2004.
- Andersen, E.Y., D.L. Hommel, and E.M. Veje, "Emergency Rehabilitation of the Zarate–Braço Largo Bridges, Argentina," *Proceedings of the IABSE Conference, Cable-Stayed Bridges, Past, Present, and Future*, Malmo, Sweden, June 1999, pp. 698–706.
- Angelo, W., "Lasers Ensure Stay Cable Safety," *Engineering News Record*, Vol. 239, No. 4, July 28, 1997, pp. 10–11.
- "B&N Creates Custom Device for Florida Cable-Stay Inspection," brochure, Burgess & Niple, Columbus, Ohio, 2005.
- Bartels, K.A., H. Kwun, and J.J. Hanley, "Magnetostrictive Sensors for the Characterization of Corrosion in Rebars and Prestressing Strands," *SPIE Proceedings*, Vol. 2946, 1996, pp. 40–50.
- Barton, J.R., C.M. Teller, and S.A. Suhler, *Design, Develop, and Fabricate a Prototype Nondestructive Inspection and Monitoring System for Structural Cables and Strands of Suspension Bridges*, Report FHWA-RD-89-158, Federal Highway Administration, Washington, D.C., 1989, 133 pp.
- Barton, S.C., G.W. Vermaas, P.F. DUBY, A.C. West, and R. Betti, "Accelerated Corrosion and Embrittlement of High-Strength Bridge Wire," *Journal of Materials in Civil Engineering*, Vol. 12, No. 1, Feb. 2000, pp. 33–38.
- Bergamini, A., R. Christen, and M. Motavalli, "A Simple Approach to the Automatic Recognition of Flaws in Large Diameter Steel Cables," 2003 [Online]. Available: <http://www.ndt.net/article/ndtce03/papers/p019/p019.htm>.
- Bierwagen, D., "Burlington Cable-Stayed Bridge Design and Construction Summary," Iowa Department of Transportation Office of Bridges and Structures, informational report prepared for FHWA and others, 33 pp., nd.
- Bloomstine, M.L. and E. Stoltzner, "The Faroe Cable-Stayed Bridge—Maintenance Experience with Major Components," *Proceedings of the IABSE Conference, Cable-Stayed Bridges, Past, Present, and Future*, Malmo, Sweden, June 1999, pp. 688–697.
- Bourmand, Y., "Development of New Stay Cable Dampers," *Proceedings of the IABSE Conference, Cable-Stayed Bridges, Past, Present, and Future*, Malmo, Sweden, June 1999, pp. 559–566.
- Bridge Design and Engineering*, London, United Kingdom, 2005 [Online]. Available: <http://www.bridgeweb.com/magazine/FeatureDetails.cfm?ArticleID=9>.
- Brönnimann, R., P.M. Nellen, and U. Sennhauser, "Application and Reliability of a Fiber Optical Surveillance System for a Stay Cable Bridge," *Smart Materials and Structures*, Vol. 7, 1998, pp. 229–236.
- Brown, J.L., "Hong Kong to Boast World's Longest Cable-Stayed Bridge," *Civil Engineering*, Vol. 71, No. 1, Jan. 2001a, p. 10.
- Brown, J.L., "Long Cable-Stayed Span Planned for St. Louis," *Civil Engineering*, Vol. 71, No. 11, Nov. 2001b, p. 16.
- Brown, K. and J. St Leger, "Use of the Megascan™ Imaging Process Inspection Systems for Post-Tensioned Bridge and Other Major Structures," 2003 [Online]. Available: <http://www.ndt.net/article/ndtce03/papers/v021/v021.htm>.
- Bruce, R., R. Drake, C. Sperry, and H. Thompson, "Aerodynamic Monitoring of the Cable-Stayed Mississippi River Bridge," *IABSE Colloquium: Monitoring of Large Structures and Assessment of Their Safety*, Bergamo, Italy, IABSE Reports, Vol. 56, 1987, pp. 191–203.
- "Cable Stays of Cable-Stayed Bridges," Technical Advisory T 5140.25, Federal Highway Administration, Washington, D.C., June 17, 1994.
- Casas, J.R., "A Combined Method for Measuring Cable Forces: The Cable-Stayed Alamillo Bridge, Spain," *Structural Engineering International*, No. 4, 1994, pp. 235–240.
- Christenson, R.E., B.F. Spencer, and E.A. Johnson, "Experimental Verification of Semiactive Damping of Stay Cables," *Proceedings of the 2001 American Control Conference*, Arlington, Va., June 25–27, 2001, pp. 5058–5063.
- Christoffersen, J., L. Hauge, H. Elgaard Jensen, and J. Bjerrum, "Design and Construction of a CFRP Cable Stayed Footbridge," *Proceedings of the IABSE Conference, Cable-Stayed Bridges, Past, Present, and Future*, Malmo, Sweden, June 1999, pp. 135–144.
- Ciolko, A.T. and H. Tabatabai, "Condition Evaluation of Prestressed Steel Strands in Concrete Bridges," *Document 23*, Transportation Research Board, National Research Council, Washington, D.C. [Online]. Available: <http://www4.nationalacademies.org/trb/CRP.nsf/all+projects/NCHRP+10-53> [Sep. 1999].
- Ciolko, A.T. and W.P. Yen, "An Immediate Payoff from FHWA's NDE Initiative," *Public Roads*, May/June 1999, Vol. 62, No. 6, pp. 10–17.
- Cunha, A. and E. Caetano, "Dynamic Measurements on Stay Cables of Cable-Stayed Bridges Using an Interferometry Laser System," *Experimental Techniques*, May/June 1999, pp. 38–43.
- Desimone, C., P. Katchadjian, M. Tacchia, and R. Giacchetta, "Damage Detection on Wires of Ropes Applying Ultrasonic Waves," *10th Asia-Pacific Conference on Non-Destructive Testing*, Brisbane, Australia, Sep. 17–21, 2001 [Online]. Available: <http://www.ndt.net/article/apcndt01/papers/1023/1023.htm>.

- Dowd, J., M. Poser, K.H. Frank, S.L. Wood, and E.B. Williamson, "Bending Fatigue of Cable Stays," *Journal of Bridge Engineering*, Vol. 6, No. 6, Nov./Dec. 2001, pp. 639–644.
- DSI, "Maumee Stay Cable Bridge Breaks World Record" [Online]. Available: <http://www.dywidag-systems.com/docs/markets.php?market=Bridges&content=maumee>, 2004.
- Elgamal, A., F. Seible, F. Vernon, M. Trivedi, and M. Fraser, "On-Line Structural Monitoring and Data Management," *Proceedings of the 6th Seismic Research Workshop*, California Department of Transportation, Sacramento, June 2001.
- Elliott, M.E. and E. Heymsfield, "Inspection of Luling Bridge Cable Stays: Case Study," *Journal of Construction Engineering and Management*, Vol. 129, No. 2, April 2003, pp. 226–230.
- Fisher, K. and S. Bassett, "Cables, Strands, and Rods Keep Tension High," *High-Performance Composites*, July/Aug. 1997, pp. 23–29.
- Frank, K.H. and J.E. Breen, "Durability of Stay Cable," *Proceedings of the High Performance Stay Cable Systems Seminar*, sponsored by Freyssinet International, Washington, D.C., Oct. 1, 2004.
- Funahashi, M., "Reliable Corrosion Protection for Bridge Stay Cables," *Concrete International*, Vol. 17, No. 2, Feb. 1995, pp. 33–37.
- Ghorbanpoor, A., "Evaluation of Prestressed Concrete Girders Using Magnetic Flux Leakage," *Proceedings of the 1999 ASCE Structures Congress, Structural Engineering in the 21st Century*, New Orleans, La., Apr. 1999, pp. 284–287.
- Gimsing, N.J., *Cable-Supported Bridges—Concept and Design*, 2nd ed., John Wiley, Chichester, West Sussex, England, 1998, 471 pp.
- Gimsing, N.J., "History of Cable-Stayed Bridges," *Proceedings of the IABSE Conference, Cable-Stayed Bridges, Past, Present, and Future*, Malmo, Sweden, June 1999, pp. 8–24.
- Grant, A., "Cables Not in Trouble," *Civil Engineering*, Vol. 61, No. 5, May 1991, pp. 61–63.
- Hamilton, H.R. and J.E. Breen, "International Survey of Current Opinion on Bridge Stay Cable Systems," *Proceedings of the IABSE Symposium Extending the Lifespan of Structures*, San Francisco, Calif., Aug. 23–25, 1995, pp. 843–853.
- Hamilton, H.R., J.E. Breen, and K.H. Frank, "Bridge Stay Cable Corrosion Protection. I: Grout Injection and Load Testing," *Journal of Bridge Engineering*, Vol. 3, No. 2, May 1998a, pp. 64–71.
- Hamilton, H.R., J.E. Breen, and K.H. Frank, "Bridge Stay Cable Corrosion Protection. II: Accelerated Corrosion Tests," *Journal of Bridge Engineering*, Vol. 3, No. 2, May 1998b, pp. 72–81.
- Harris, C.A., "Cradle System Anchors Stay Cables to Decks," *Civil Engineering*, Vol. 72, No. 3, 2002, p. 36.
- Hemmert, H.A. and S. Sczyslo, "Corrosion Protection of Locked Coil Ropes at Road Bridges," *Proceedings of the IABSE Conference, Cable-Stayed Bridges, Past, Present, and Future*, Malmo, Sweden, June 1999, pp. 586–595.
- Hooks, J., et al., "FHWA Study Tour for Advanced Composites in Bridges in Europe and Japan," National Transportation Library, Washington, D.C., Oct. 1997 [Online]. Available: <http://ntl.bts.gov/DOCS/advcom3a.html>.
- "Immersion of Stays Protects Bridge Cables," *Civil Engineering News*, Vol. 5, No. 1, Feb. 1993, p. 9.
- Irwin, P., "Wind Vibrations of Cables on Cable-Stayed Bridges," *Proceedings of the ASCE Structures Congress XV, Building to Last*, Vol. 1, Portland, Ore., April 13–16, 1997, pp. 383–387.
- Ito, M., "Stay Cable Technology: Overview," *Proceedings of the IABSE Conference, Cable-Stayed Bridges, Past, Present, and Future*, Malmo, Sweden, June 1999, pp. 481–490.
- Jensen, C.N., S.R.K. Nielsen, and J.D. Sorensen, "Optimal Damping of Stays in Cable-Stayed Bridges for In-Plane Vibrations," *Journal of Sound and Vibration*, Vol. 256, No. 3, 2002, pp. 499–513.
- Johnson, E.A., G.A. Baker, B.F. Spencer, and Y. Fujino, "Semiactive Damping of Stay Cables," 2002 [Online]. Available: http://rcf.usc.edu/~johnsone/papers/smartdamping_tautcable_jem.html.
- Johnson, E.A., G.A. Baker, B.F. Spencer, and Y. Fujino, "Mitigating Stay Cable Oscillation Using Semiactive Damping," *Proceedings of the Smart Structures and Materials 2000: Smart Systems for Bridges, Structures, and Highways*, S.C. Liu, Ed., SPIE, Vol. 3988, pp. 207–216.
- Jones, N.P. and M. Porterfield, "Measurement of Stay-Cable Vibration," *Proceedings of the ASCE Structures Congress XV—Building to Last*, ASCE, Portland, Ore., April 13–16, 1997, pp. 1290–1294.
- Keating, S., T.N. Claytor, A. Davis, and M. Sheats, "Technological Advancements for High-Speed Industrial Computed Tomography," *Proceedings of the Structures Congress 2000—Advanced Technology in Structural Engineering*, Philadelphia, Pa., May 8–10, 2000.
- Kitagawa, M., S. Suzuki, and M. Okuda, "Assessment of Cable Maintenance Technologies for Honshu–Shikoku Bridges," *Journal of Bridge Engineering*, Vol. 6, No. 6, Nov./Dec. 2001, pp. 418–424.
- Ko, J.M., G. Zheng, Z.Q. Chen, and Y.Q. Yi, "Field Vibration Tests of Bridge Stay Cables Incorporated with Magneto-Rheological (MR) Dampers," *Proceedings of SPIE—The International Society for Optical Engineering*, Vol. 4696—Smart Structures and Materials 2002, Smart Systems for Bridges, Structures, and Highways, pp. 30–40.
- Kovacs, I., "Zur frage der seil-schwingungen und der seildampfung," *Die Bautechnik*, 10, pp. 325–332 (in German).
- Kumarasena, S., N.P. Jones, P. Irwin, and P. Taylor, *Wind Induced Vibration of Stay Cables*, Report submitted to the

- Federal Highway Administration, Contract No. DTFH61-99-C-00095, 2002.
- Kwon, H., "Waves of the Future," *SwRI Technology Today Article*, 2003 [Online]. Available: <http://www.swri.edu/3pubs/ttoday/fall03/Future.htm>.
- Lankin, J., J. Kilpatrick, P.A. Irwin, and N. Alca, "Wind-Induced Stay Cable Vibrations—Measurement and Mitigation," *Proceedings of the ASCE Structures Congress*, Philadelphia, Pa., May 8–10, 2000.
- Larose, G.L. and L. Wagner Smitt, "Rain/Wind Induced Vibrations of Parallel Stay Cables," *Proceedings of the IABSE Conference, Cable-Stayed Bridges, Past, Present, and Future*, Malmo, Sweden, June 1999, pp. 310–311.
- Little, B., R. Staehle, and R. Davis, "Fungal Influenced Corrosion of Post-Tensioned Cables," *International Biodeterioration and Biodegradation*, Vol. 47, No. 2, 2001, pp. 71–77.
- Liu, W., R. Hunsperger, M. Chajes, K. Folliard, and E. Kunz, "Corrosion Detection of Steel Cables Using Time Domain Reflectometry," *Journal of Materials in Civil Engineering*, Vol. 14, No. 3, 2002, pp. 217–223.
- Main, J.A. and N. P. Jones, "A Comparison of Full-Scale Measurements of Stay Cable Vibration," *Proceedings of the ASCE Structures Congress*, Philadelphia, Pa., May 8–10, 2000.
- Main, J.A. and N.P. Jones, "Evaluation of Viscous Dampers for Stay-Cable Vibration Mitigation," *Journal of Bridge Engineering*, Vol. 6, No. 6, Nov./Dec. 2001, pp. 385–397.
- Main, J.A. and N.P. Jones, "Free Vibrations of Taut Cable with Attached Damper: I. Linear Viscous Damper," *Journal of Engineering Mechanics*, Vol. 128, No. 10, Oct. 2002, pp. 1062–1071.
- Marsh, D., "Cable Ready," *Concrete Products*, April 2003 [Online]. Available: http://concreteproducts.com/mag/concrete_cable_ready/.
- Matsumoto, M., "Inclined Cable Aerodynamics of Cable-Stayed Bridges," *Proceedings of the ASCE Structures Congress*, Philadelphia, Pa., May 8–10, 2000.
- Mayrbaurl, R.M. and S. Camo, *NCHRP Report 534: Guidelines for Inspection and Strength Evaluation of Suspension Bridge Parallel-Wire Cables*, Transportation Research Board, National Research Council, Washington, D.C., 2004.
- Mehrabi, A.B., H. Tabatabai, and H.R. Lotfi, "Damage Detection in Structures Using Precursor Transformation Method," *Journal of Intelligent Material Systems and Structures*, Vol. 9, No. 10, Oct. 1999, pp. 808–817.
- Miyazaki, M., "Aerodynamic and Structural Dynamic Control System of Cable-Stayed Bridge for Wind Induced Vibration," *Proceedings of the IABSE Conference, Cable-Stayed Bridges, Past, Present, and Future*, Malmo, Sweden, June 1999, pp. 86–94.
- Mizoe, M., S. Muroi, T. Horii, T. Isobe, R. Kiyota, and Y. Imada, "The Super High Damping Rubber Damper on the Stay Cables of the Meiko East Bridge," *Proceedings of the IABSE Conference, Cable-Stayed Bridges, Past, Present, and Future*, Malmo, Sweden, June 1999.
- Noro, T., S. Konno, and H. Maikuma, "Material Properties of Carbon-Fiber Cables for Suspension Bridges," *Proceedings of the IABSE Conference, Cable-Supported Bridges, Challenging Technical Limits*, Seoul, Korea, June 12–14, 2001, pp. 126–127.
- Pacheco, B.M., Y. Fujino, and A. Sulekh, "Estimation Curve for Modal Damping in Stay Cables with Viscous Damper," *Journal of Structural Engineering*, Vol. 119, No. 6, June 1993, pp. 1961–1979.
- Phelan, R.S., P.P. Sarkar, K.C. Mehta, T.B. Gardner, and Z. Zhan, "Distributed Aerodynamic and Mechanical Damping of Cables with Active Smart Control," USPTO Patent No. 6,435,323 B2, Aug. 20, 2002.
- Phelan, R.S., P.P. Sarkar, K.C. Mehta, T. B. Gardner, and Z. Zhan, "Cable Stay Damper Band and Method of Use for Reduction of Fluid Induced Cable Vibrations," USPTO Patent No. 6,705,440 B2, Mar. 16, 2004.
- Pla-Rucki, G.F. and M.O. Eberhard, "Imaging of Reinforced Concrete: State-of-the-Art Review," *Journal of Infrastructure Systems*, Vol. 1, No. 2, June 1995, pp. 134–141.
- Podolny, W., "Cable-Stayed Bridges—Future Developments, North American Viewpoint," *ASCE Annual Convention*, New York, N.Y., Sep. 13–17, 1992.
- Poston, R.W., "Evaluation and Mitigation of Rain Vibration of Stay Cables," 2002 [Online]. Available: http://www.asbi-assoc.org/news_research/winter_02/vibration.cfm.
- Prato, C.A. and M.A. Ceballos, "Dynamic Bending Stresses Near the Ends of Parallel-Bundle Stay Cables," *Structural Engineering International*, Vol. 13, No. 1, Feb. 2003, pp. 64–68.
- Prato, C.A., M.A. Ceballos, P.J.F. Huerta, C.F. Gerbaudo, C.E. Grunbaum, and D.L. Hommel, "Diagnosis, Construction Procedures, and Design Recommendations for Replacement of Cables in Cable-Stayed Bridges: Experience from Two Current Cases in Argentina," *Proceedings of the US–Canada Workshop of Bridge Engineering*, July 1997, pp. 303–316.
- Prato, C.A., M.A. Ceballos, P.J.F. Huerta, and C.F. Gerbaudo, "Application of Ambient Vibration Measurements for Repair of the Chaco–Corrientes Cable-Stayed Bridge in Argentina," *Proceedings of the International Seminar, Workshop and Exhibition/The Repair and Rehabilitation of Reinforced Concrete Structures; The State of the Art*, 1998, pp. 177–191.
- Recommendations for Stay Cable Design, Testing, and Installation*, 4th ed., Post-Tensioning Institute, Phoenix, Ariz., 2001, 101 pp.
- Reinholdt, P., E. Veje, and J. Kalvslund, "Rehabilitation of the Luangwa Bridge," *Proceedings of the IABSE Conference, Cable-Stayed Bridges, Past, Present, and Future*, Malmo, Sweden, June 1999.

- Rizzo, P. and F. Lanza di Scalea, "Wave Propagation in Multi-wire Strands by Wavelet-Based Laser Ultrasound," *Experimental Mechanics*, Vol. 44, No. 3, 2004.
- Roos, F. and J.F. Noisternig, "CFRP-Tendons—Development and Testing," *Proceedings of the IABSE Conference, Cable-Stayed Bridges, Past, Present, and Future*, Malmo, Sweden, June 1999, pp. 623–630.
- Saito, T., M. Matsumoto, and M. Kitazawa, "Rain–Wind Excitation of Cables on Cable-Stayed Higashi–Kobe Bridge and Cable Vibration Control," *Proceedings of Conference on Cable-Stayed and Suspension Bridges*, Deauville, France, Oct. 1994, pp. 507–514.
- Sarcos-Portillo, A., A. Navarro-Cerpa, and H. Garcia-Legl, "Inspection and Process of Tension of Cables of General Rafael Urdaneta Bridge," *Journal of Bridge Engineering*, Vol. 8, No. 4, July 2003, pp. 223–228.
- Sarkar, P.P., S. Phelan, K.C. Mehta, T.B. Gardner, and Z. Zhao, "Cable Stay Aerodynamic Damper Band and Method of Use," USPTO Patent No. 6,386,526, May 14, 2002.
- Saul, R. and H.S. Svensson, "On the Corrosion Protection of Stay Cables," *Wire Rope News and Sling Technology*, Aug. 1991, pp. 14–29.
- Seible, F. and R. Burgueno, "Advanced Composites in Pedestrian Bridge Design," *Proceedings of the ASCE Structures Congress XV*, Vol. 1, Portland, Ore., April 13–16, 1997, pp. 378–382.
- Stafford, D.G. and S.C. Watson, "A Discussion of Some Critical Corrosion Problems in the Cable Elements of Stayed Girder Structures," *Proceedings of the US–European Workshop on Bridge Evaluation, Repair, and Rehabilitation*, St. Remy-les-Chevreuse, June 1987, pp. 622–637.
- Starossek, U., "Cable-Dynamics, A Review," *Structural Engineering International*, No. 3, 1994, pp. 171–176.
- Stubler, J., P. Ladret, and J.B. Domage, "Vibration Control of Stay Cables," *Proceedings of the IABSE Conference, Cable-Stayed Bridges, Past, Present, and Future*, Malmo, Sweden, June 1999, pp. 606–612.
- Suzuki, N., H. Takamatsu, S. Kawashima, K. Sugii, and M. Iwasaki, "Ultrasonic Detection Method for Wire Breakage," *Kobelco Technology Review*, No. 4, Aug. 1988, pp. 23–26.
- Suzumura, K. and S.-I. Nakamura, "Environmental Factors Affecting Corrosion of Galvanized Steel Wires," *Journal of Materials in Civil Engineering*, Vol. 16, No. 1, Feb. 2004, pp. 1–7.
- Swan, R., "Vibrations Damped," *Bridge Design & Engineering*, Nov. 1997, Vol. 3, No. 9.
- Tabatabai, H., A.T. Ciolko, and T.J. Dickson, "Implications of Test Results from Full-Scale Fatigue Tests of Stay Cables Composed of Seven-Wire Prestressing Strands," *Proceedings of the Fourth International Bridge Engineering Conference*, Vol. 1, Aug. 28–30, 1995, pp. 266–277.
- Tabatabai, H. and A.B. Mehrabi, "Bridge Stay Cable Condition Assessment Using Vibration Measurement Techniques," *Proceedings of SPIE Structural Materials Technology III, an NDT Conference*, Vol. 3400, Mar.–Apr. 1998, San Antonio, Tex., pp. 194–204.
- Tabatabai, H., A. Mehrabi, and A.G. Davis, "Field Testing of Stay Cables for the Cochrane Bridge in Mobile, Alabama," Report submitted to A.G. Lichtenstein, Inc., Paramus, N.J., Construction Technology Laboratories, Inc., Skokie, Ill., 1998.
- Tabatabai, H. and A. Mehrabi, "Vibration Suppression Measures for Stay Cables," *Proceedings of the 17th International Modal Analysis Conference*, Kissimmee, Fla., Feb. 1999, pp. 1237–1243.
- Tabatabai, H. and A. Mehrabi, "Evaluation of Various Damping Treatments for Stay Cables," *Proceedings of the 18th International Modal Analysis Conference*, San Antonio, Tex., Feb. 2000.
- Tabatabai, H. and A.B. Mehrabi, "Design of Mechanical Viscous Dampers for Stay Cables," *Journal of Bridge Engineering*, Vol. 5, No. 2, May 2000, pp. 114–123.
- Tabatabai, H. and A.B. Mehrabi, "TMD-Damped Stay Cable and Method and TMD," USPTO Patent No. 6,292,967 B1, Sep. 25, 2001.
- Tarui, T., N. Maruyama, T. Eguchi, and S. Konno, "Development of High Strength Galvanized Steel Wire for Bridge Cable," *Proceedings of the IABSE Conference, Cable-Supported Bridges, Challenging Technical Limits*, Seoul, Korea, 2001.
- Telang, N.M., C.M. Minervino, and P.G. Norton, "Retrofit of Aerodynamic Cable Instability on a Cable-Stayed Bridge: Case Study," *Transportation Research Record 1740*, Transportation Research Board, National Research Council, Washington, D.C., 2000, pp. 61–67.
- Telang, N.M., C.A. Ligozio, and A.B. Mehrabi, "Luling Bridge—Phase II Structural Evaluation of Luling Bridge Stay Cable Array—Tasks 1, 2, and 3," Report to the Louisiana Department of Transportation and Development, State Project No. 700-45-0107, Construction Technology Laboratories, Skokie, Ill., July 2004.
- Walther, R., et al. *Cable Stayed Bridges*, 2nd ed., Thomas Telford, London, 1999, 320 pp.
- Walton, J.M., "Developments in Steel Cables," *Journal of Constructional Steel Research*, Vol. 39, No. 1, 1996, pp. 3–29.
- Watson, S.C. and D. Stafford, "Cables in Trouble," *Civil Engineering*, Vol. 58, No. 4, Apr. 1988, pp. 38–41.
- Weischedel, H.R. and H.-W. Hohle, "Quantitative Non-Destructive In-Service Evaluation of Stay Cables of Cable-Stayed Bridges: Methods and Practical Experience," *SPIE*, Vol. 2456, May 1995, pp. 226–236.
- Wichmann, H.J., A. Holst, and H. Budelmann, "Detection and Localization of Fractures in Tendons by Means of Electromagnetic Resonance Measurement," 2003 [Online]. Available: <http://www.ndt.net/article/ndtce03/papers/v104/v104.htm>.
- Wu, Q., K. Takahashi, T. Okabayashi, and S. Nakamura, "Response Characteristics of Local Vibrations in Stay Cables on an Existing Cable-Stayed Bridge," *Journal of Sound and Vibration*, Vol. 261, No. 3, Mar. 27, 2003, pp. 403–420.

- Yamagiwa, I., H. Utsuno, K. Endo, and K. Sugii, "Application of Simultaneous Identification of Tension and Flexural Rigidity at Once to the Bridge Cables," *Proceedings of the IABSE Conference, Cable-Stayed Bridges, Past, Present, and Future*, Malmo, Sweden, June 1999.
- Yamaguchi, K., Y. Manabe, N. Sasaki, and K. Morishita, "Field Observation and Vibration Test of the Tatara Bridge," *Proceedings of the IABSE Conference, Cable-Stayed Bridges, Past, Present, and Future*, Malmo, Sweden, June 1999, pp. 707–714.
- Yoneda, M. and K. Maeda, "A Study on Practical Estimation Method for Structural Damping of Stay Cable with Damper," *Proceedings of the Canada–Japan Workshop on Bridge Aerodynamics*, Ottawa, Canada, Sep. 1989, pp. 119–128.
- Xu, Y.L., S. Zhan, and J.M. Ko, "Experimental Study of Vibration Mitigation of Bridge Stay Cables," *Journal of Structural Engineering*, Vol. 125, No. 9, Sep. 1999, pp. 977–986.
- Zoli, T. and R. McCabe, "Cable-Stayed Bridge Design," Presented at the High Performance Stay Cable Systems Seminar, sponsored by Freyssinet International, Washington, D.C., Oct. 1, 2004.

APPENDIX A

Survey Questionnaire

NATIONAL COOPERATIVE HIGHWAY RESEARCH PROGRAM

SYNTHESIS TOPIC 35-07

INSPECTION AND MAINTENANCE OF BRIDGE STAY CABLE SYSTEMS

QUESTIONNAIRE

With this request for information, we are seeking your help in developing a synthesis report on inspection and maintenance of stay cables in cable-stayed bridges. You and your agency have been selected because of the relevant knowledge and experience that we believe can be shared with us that are important to the success of this effort. We are striving to make the outcome of this effort (i.e., the synthesis report) a valuable and state-of-the-art resource for those such as yourself who are involved in the inspection, design, maintenance, or repair/retrofit of stay cables. The synthesis will focus on the advantages and limitations of various non-destructive test methods, repair procedures, preventive maintenance strategies, vibration control methods, corrosion protection systems, fatigue, etc. Please feel free to contact the consultant for this synthesis project, Dr. Habib Tabatabai, at (414) 229-5166 or ht@uwm.edu should you have any questions. You may also receive a call or e-mail from the consultant for the purpose of clarifying or augmenting your answers to the questions. Please provide any additional information that you feel is relevant to the answers provided in the questionnaire. Thank you in advance for your valued input into this effort.

Respondent Information:

Please provide the information requested below for the person completing this questionnaire (if you received the questionnaire and someone else is in a better position to respond, please forward the document to that person).

Agency: _____
 Name: _____
 Title: _____
 Street address: _____
 City: _____
 State: _____
 Zip code: _____
 Telephone: _____
 Fax: _____
 E-mail: _____

Please return the completed questionnaire and any supporting documents by e-mail, fax, or mail by Friday March 26, 2004 to:

Habib Tabatabai
 Department of Civil Engineering & Mechanics
 University of Wisconsin–Milwaukee
 3200 N. Cramer Street
 Milwaukee, WI 53211
 Telephone: (414) 229-5166 Fax: (414) 229-6958
 E-mail: ht@uwm.edu

QUESTIONS

Please feel free to expand on your answers to the following questions. If you need additional space, you can use the comments section at the end of this questionnaire.

- 1) Are you or your agency involved in the design, fabrication, inspection, testing, repair, maintenance, or retrofit of stay cables in cable-stayed bridges?

Yes No

If the answer is “Yes,” please proceed to the next question. If the answer is “No,” please return the questionnaire as directed above and thank you for your time. Please note that submitting a “blank” questionnaire is preferred to not submitting.

- 2) Is your agency an owner (or responsible for the maintenance) of at least one cable-stayed bridge?

Yes No Soon

If the answer is “Yes” or “Soon,” please proceed to the next question. If the answer is “No,” please proceed to question No. 5.

- 3) How many cable-stayed bridges are under the jurisdiction of your agency or are maintained by your agency?

1 2 3 over 3 (please provide number)

- 4) Please provide the following information on each of the cable-stayed bridges that are maintained by your agency. (If you have more than two cable-stayed bridges, please provide the requested information on additional sheets. Also, please note that MTE refers to the main tension-resisting elements in the cable, which are typically 7-wire strands, parallel wires, or bars.)

No.	Questions	Bridge No. 1	Bridge No. 2
4-1	Bridge name and location		
4-2	Year built		
4-3	Main span length (ft)		
4-4	Type of main tension element (MTE)? (7-wire steel strand, steel wire, steel bar or threadbar, rope, helical lock-coil strand, other)		
4-5	Coating/treatment on main tension element within free length of cable? (bare, greased-and-sheathed, epoxy-coated on outside only, epoxy-coated inside and outside, galvanized steel, stainless steel, other)		
4-6	Are the coatings/treatments on main tension element discontinued or removed within the anchorage zone? (yes, no, not known, not applicable)		
4-7	Type of grout used? (grout not used, cement-water, cement-water-admixtures, commercial pre-packaged grouts, not known)		
4-8	Are filler materials used in the anchorage zone? (yes—grout, yes—grease, yes—other, no filler, not known)		
4-9	Type of anchorage? (wedges, conical socket with wedges, cylindrical sockets with wedges, “Hi-Am”-type, other)		
4-10	Do cables go over “saddles” on the pylons? (yes, no)		
4-11	Type of cable sheathing used? [HDPE with PVF (Tedlar®) tape, UV-resistant HDPE, UV-resistant HDPE with spiral on surface, HDPE with dimples on the surface, steel pipe, no sheathing, other]		

No.	Questions	Bridge No. 1	Bridge No. 2
4-12	Have rain–wind-induced cable vibrations been observed on this bridge? (<i>yes, no, not known</i>)		
4-13	Have MTE corrosion problems been noted? (<i>yes, no, not known</i>)		
4-14	Do cables have neoprene rings near the top and bottom anchorages? (<i>yes, no, not known</i>)		
4-15	If there are neoprene rings on the cables, have there been any reports of movements of the rings out of their positions? (<i>yes—due to loosening of retainers, yes—due to shearing off of retainers, yes—due to other reasons, no, not known, not applicable</i>)		
4-16	Has moisture been found in any of the internal components of stay cables such as the bottom anchorage areas? (<i>yes, no, not tested, not known</i>)		
4-17	Has fatigue of MTE or other components of stay cables been observed (<i>yes, no, not known</i>)		
4-18	Do the cables have viscous dampers installed at deck or tower levels? (<i>yes—from the beginning, yes—retrofitted to correct vibrations, no</i>)		
4-19	Do the cables have cross cables installed between them? (<i>yes—from the beginning, yes—retrofitted to correct vibrations, no</i>)		
4-20	Do cables have other dampers (other than viscous or neoprene rings) to control vibrations? [<i>yes—tuned mass dampers, yes—other dampers (please specify), no, not known</i>]		
4-21	Has cracking of the cable sheathing or sheathing connections been noted? (<i>yes—sheathing, yes—connections, yes—both, no, not known, not applicable</i>)		
4-22	Has cracking or misalignment of the guide pipes been noted? (<i>yes—cracking, yes—misalignment, yes—both, no, not known, not applicable</i>)		
4-23	If there is protective tape wrapped around the cable sheathing, have there been reports of deterioration of the tape? (<i>yes—minor damage, yes—moderate damage, yes—extensive damage, no, not known, not applicable</i>)		
4-24	Have any problems associated with neoprene boots been noted? (<i>yes, no, not known, not applicable</i>)		
4-25	Types of non-destructive tests that any of the cables on this bridge have been subjected to? [<i>magnetic, X-ray, ultrasonic, vibration-based force measurements, other (please specify), not performed, not known</i>]		
4-26	Types of sensor-based long-term monitoring performed on the cables? [<i>acoustic wire break detection, vibration monitoring, force measurements, other (please specify), not performed, not known</i>]		
4-27	Have the cables on this bridge (or any of their components) been repaired? [<i>yes (please explain), no, not known</i>]		
4-28	Has the sheathing been partially removed on any of the cables to examine condition of grout (if applicable) and/or the MTE? (<i>yes, no, not known, not applicable</i>)		
4-29	Can the strands or cables be replaced if needed? (<i>yes, no, not known</i>)		
4-30	Do you have an inspection and maintenance manual for this bridge? (<i>yes, no, not known</i>)— <i>If yes, we would appreciate receiving a copy of this manual for the purposes of this synthesis report.</i>		

- 5) Based on your experience and in general, do you believe that the current inspection, testing, monitoring, and repair methods available to you for stay cables are effective and adequate?
 - Yes
 - No
 - Not known

- 6) Please comment on the effectiveness of any non-destructive test methods for inspections of stay cables that you may be familiar with. These methods include (but are not limited to) ultrasonic testing, magnetic inspections, laser-based force measurements, X-ray imaging, etc. If possible, please comment on issues such as practicality, cost, duration, impact on traffic, and any other factors that you consider important.

- 7) Please comment on the effectiveness of any cable vibration control measures that you may be familiar with. Examples include installation of cross cables, viscous dampers, neoprene rings, etc.

- 8) Please comment on the effectiveness of any sensor-based long-term monitoring systems for stay cables that you may be familiar with. Examples include acoustic monitoring, vibration monitoring, force measurements, strain measurements, etc.

- 9) What would you recommend that the cable suppliers incorporate into their systems to make cables more accessible and inspectable?

- 10) Do you believe that an up-to-date resource such as a national database of information on stay cable inspection methods, repairs, and testing would be a useful tool?
 - Yes
 - No
 - Not known

- 11) What do you see as the single most important problem in stay cable maintenance?

- 12) Please comment on any other methods for inspections, testing, monitoring, and repair of stay cable (including conventional methods) that you have found beneficial and are not listed above.

Additional comments?

We appreciate the time you have taken to provide this information and thank you very much for your help with this important undertaking.

APPENDIX B

Statistical Analysis of Survey Results

QUESTION 4.4
TYPE OF MAIN TENSION ELEMENT (MTE)?

	U.S.	% U.S.	Canada	% Canada	% Total
Seven-wire steel strand	21	75.0	1	7.7	53.7
Steel wire	3	10.7	7	53.8	24.4
Steel bar or threadbar	1	3.6	4	30.8	12.2
Other	2	7.1	1	7.7	7.3
No answer	1	3.6	0	0.0	2.4

QUESTION 4.5
COATING/TREATMENT ON MAIN TENSION ELEMENT WITHIN FREE LENGTH OF CABLE?

	U.S.	% U.S.	Canada	% Canada	% Total
Bare	12	42.9	0	0.0	29.3
Greased-and-sheathed	6	21.4	0	0.0	14.6
Epoxy-coated outside only	4	14.3	0	0.0	9.8
Epoxy-coated in and out	1	3.6	0	0.0	2.4
Galvanized	3	10.7	8	61.5	26.8
Stainless steel	0	0.0	0	0.0	0.0
Other	1	3.6	5	38.5	14.6
No answer	1	3.6	0	0.0	2.4

QUESTION 4.6
ARE THE COATINGS/TREATMENTS ON MAIN TENSION ELEMENT DISCONTINUED OR REMOVED WITHIN THE ANCHORAGE ZONE?

	U.S.	% U.S.	Canada	% Canada	% Total
Yes	9	32.1	2	15.4	26.8
No	1	3.6	9	69.2	24.4
Not known	7	25.0	2	15.4	22.0
Not applicable	10	35.7	0	0.0	24.4
No answer	1	3.6	0	0.0	2.4

QUESTION 4.7
TYPE OF GROUT USED?

	U.S.	% U.S.	Canada	% Canada	% Total
Grout not used	6	21.4	12	92.3	43.9
Cement-water	5	17.9	0	0.0	12.2
Cement-water-admixtures	9	32.1	0	0.0	22.0
Commercial prepackaged grouts	1	3.6	0	0.0	2.4
Not known	6	21.4	0	0.0	14.6
Not applicable	0	0.0	1	7.7	2.4
No answer	1	3.6	0	0.0	2.4

QUESTION 4.8
ARE FILLER MATERIALS USED IN THE ANCHORAGE ZONE?

	U.S.	% U.S.	Canada	% Canada	% Total
Yes—grout	6	21.4	0	0.0	14.6
Yes—grease	10	35.7	0	0.0	24.4
Yes—other	7	25.0	2	15.4	22.0
No filler	0	0.0	11	84.6	26.8
Not known	4	14.3	0	0.0	9.8
No answer	1	3.6	0	0.0	2.4

QUESTION 4.9
TYPE OF ANCHORAGE?

	U.S.	% U.S.	Canada	% Canada	% Total
Wedges	6	21.4	0	0.0	14.6
Conical socket with wedges	13	46.4	2	15.4	36.6
Cylindrical sockets with wedges	0	0.0	0	0.0	0.0
“Hi-Am” type	3	10.7	0	0.0	7.3
Other	3	10.7	11	84.6	34.1
Not known	2	7.1	0	0.0	4.9
No answer	1	3.6	0	0.0	2.4

QUESTION 4.10
DO CABLES GO OVER SADDLES ” ON THE PYLONS?

	U.S.	% U.S.	Canada	% Canada	% Total
Yes	6	21.4	1	7.7	17.1
No	21	75.0	12	92.3	80.5
No answer	1	3.6	0	0.0	2.4

QUESTION 4.11
TYPE OF CABLE SHEATHING USED?

	U.S.	% U.S.	Canada	% Canada	% Total
HDPE with PVF (Tedlar© tape)	10	35.7	0	0.0	24.4
UV-resistant HDPE	0	0.0	1	7.7	2.4
UV-resistant HDPE with spiral on surface	7	25.0	1	7.7	19.5
HDPE with dimples on the surface	0	0.0	0	0.0	0.0
Steel pipe	2	7.1	0	0.0	4.9
No sheathing	3	10.7	9	69.2	29.3
Other	3	10.7	2	15.4	12.2
No answer	3	10.7	0	0.0	7.3

QUESTION 4.12
HAVE RAIN-WIND-INDUCED CABLE VIBRATIONS BEEN OBSERVED ON THIS BRIDGE?

	U.S.	% U.S.	Canada	% Canada	% Total
Yes	6	21.4	6	46.2	29.3
No	17	60.7	5	38.5	53.7
Not known	3	10.7	2	15.4	12.2
Not applicable	1	3.6	0	0.0	2.4
No answer	1	3.6	0	0.0	2.4

QUESTION 4.13
HAVE MTE CORROSION PROBLEMS BEEN NOTED?

	U.S.	% U.S.	Canada	% Canada	% Total
Yes	1	3.6	2	15.4	7.3
No	20	71.4	8	61.5	68.3
Not known	5	17.9	3	23.1	19.5
Not applicable	1	3.6	0	0.0	2.4
No answer	1	3.6	0	0.0	2.4

QUESTION 4.14
DO CABLES HAVE NEOPRENE RINGS NEAR THE TOP AND BOTTOM ANCHORAGES?

	U.S.	% U.S.	Canada	% Canada	% Total
Yes	18	64.3	4	30.8	53.7
No	7	25.0	9	69.2	39.0
Not known	1	3.6	0	0.0	2.4
Not applicable	1	3.6	0	0.0	2.4
No answer	1	3.6	0	0.0	2.4

QUESTION 4.15
IF THERE ARE NEOPRENE RINGS ON THE CABLES, HAVE THERE BEEN ANY REPORTS OF MOVEMENTS OF THE RINGS OUT OF THEIR POSITIONS?

	U.S.	% U.S.	Canada	% Canada	% Total
Yes—due to loosening of retainers	4	14.3	0	0.0	9.8
Yes—due to shearing off of retainers	1	3.6	1	7.7	4.9
Yes—due to other reasons	2	7.1	1	7.7	7.3
No, not known	12	42.9	2	15.4	34.1
Not applicable	8	28.6	9	69.2	41.5
No answer	1	3.6	0	0.0	2.4

QUESTION 4.16
HAS MOISTURE BEEN FOUND IN ANY OF THE INTERNAL COMPONENTS OF STAY CABLES SUCH AS THE BOTTOM ANCHORAGE AREAS?

	U.S.	% U.S.	Canada	% Canada	% Total
Yes	7	25.0	0	0.0	17.1
No	13	46.4	7	53.8	48.8
Not tested	3	10.7	6	46.2	22.0
Not known	3	10.7	0	0.0	7.3
Not applicable	1	3.6	0	0.0	2.4
No answer	1	3.6	0	0.0	2.4

QUESTION 4.17
HAS FATIGUE OF MTE OR OTHER COMPONENTS OF STAY CABLES BEEN OBSERVED?

	U.S.	% U.S.	Canada	% Canada	% Total
Yes	1	3.6	2	15.4	7.3
No	25	89.3	10	76.9	85.4
Not known	0	0.0	1	7.7	2.4
Not applicable	1	3.6	0	0.0	2.4
No answer	1	3.6	0	0.0	2.4

QUESTION 4.18
DO THE CABLES HAVE VISCOUS DAMPERS INSTALLED AT DECK OR TOWER LEVELS?

	U.S.	% U.S.	Canada	% Canada	% Total
Yes—from the beginning	4	14.3	0	0.0	9.8
Yes—retrofitted to correct vibrations	2	7.1	3	23.1	12.2
No	21	75.0	10	76.9	75.6
No answer	1	3.6	0	0.0	2.4

QUESTION 4.19
DO THE CABLES HAVE CROSS CABLES INSTALLED BETWEEN THEM?

	U.S.	% U.S.	Canada	% Canada	% Total
Yes—from the beginning	6	21.4	2	15.4	19.5
Yes—retrofitted to correct vibrations	3	10.7	1	7.7	9.8
No	18	64.3	10	76.9	68.3
No answer	1	3.6	0	0.0	2.4

QUESTION 4.20
DO CABLES HAVE OTHER DAMPERS (OTHER THAN VISCOUS OR NEOPRENE RINGS) TO CONTROL VIBRATIONS?

	U.S.	% U.S.	Canada	% Canada	% Total
Yes—tuned mass dampers	0	0.0	0	0.0	0.0
Yes—other dampers	3	10.7	3	23.1	14.6
No	24	85.7	10	76.9	82.9
Not known	0	0.0	0	0.0	0.0
No answer	1	3.6	0	0.0	2.4

QUESTION 4.21
HAS CRACKING OF THE CABLE SHEATHING OR SHEATHING CONNECTIONS BEEN NOTED?

	U.S.	% U.S.	Canada	% Canada	% Total
Yes—sheathing	3	10.7	0	0.0	7.3
Yes—connections	1	3.6	0	0.0	2.4
Yes—both	0	0.0	0	0.0	0.0
No	17	60.7	5	38.5	53.7
Not known	1	3.6	0	0.0	2.4
Not applicable	4	14.3	8	61.5	29.3
No answer	2	7.1	0	0.0	4.9

QUESTION 4.22
HAS CRACKING OR MISALIGNMENT OF THE GUIDE PIPES BEEN NOTED?

	U.S.	% U.S.	Canada	% Canada	% Total
Yes—cracking	1	3.6	0	0.0	2.4
Yes—misalignment	4	14.3	0	0.0	9.8
Yes—both	0	0.0	0	0.0	0.0
No	17	60.7	2	15.4	46.3
Not known	3	10.7	0	0.0	7.3
Not applicable	2	7.1	11	84.6	31.7
No answer	1	3.6	0	0.0	2.4

QUESTION 4.23
IF THERE IS PROTECTIVE TAPE WRAPPED AROUND THE CABLE SHEATHING, HAVE THERE BEEN REPORTS OF DETERIORATION OF THE TAPE?

	U.S.	% U.S.	Canada	% Canada	% Total
Yes—minor damage	5	17.9	1	7.7	14.6
Yes—moderate damage	1	3.6	0	0.0	2.4
Yes—extensive damage	1	3.6	0	0.0	2.4
No	9	32.1	2	15.4	26.8
Not known	0	0.0	1	7.7	2.4
Not applicable	11	39.3	9	69.2	48.8
No answer	1	3.6	0	0.0	2.4

QUESTION 4.24
HAVE ANY PROBLEMS ASSOCIATED WITH NEOPRENE BOOTS BEEN NOTED?

	U.S.	% U.S.	Canada	% Canada	% Total
Yes	4	14.3	1	7.7	12.2
No	19	67.9	6	46.2	61.0
Not known	1	3.6	0	0.0	2.4
Not applicable	1	3.6	3	23.1	9.8
Other	2	7.1	0	0.0	4.9
No answer	1	3.6	3	23.1	9.8

QUESTION 4.25
 TYPES OF NON-DESTRUCTIVE TESTS THAT ANY OF THE
 CABLES ON THIS BRIDGE HAVE BEEN SUBJECTED TO?

	U.S.	% U.S.	Canada	% Canada	% Total
Magnetic	1	3.6	1	7.7	4.9
X-ray	1	3.6	0	0.0	2.4
Ultrasonic	1	3.6	1	7.7	4.9
Vibration-based force measurements	9	32.1	3	23.1	29.3
Other	1	3.6	0	0.0	2.4
Not performed	13	46.4	10	76.9	56.1
Not known	0	0.0	0	0.0	0.0
No answer	2	7.1	0	0.0	4.9

QUESTION 4.26
 TYPES OF SENSOR-BASED LONG-TERM MONITORING
 PERFORMED ON THE CABLES?

	U.S.	% U.S.	Canada	% Canada	% Total
Acoustic wire break detection	3	10.7	1	7.7	9.8
Vibration monitoring	2	7.1	1	7.7	7.3
Force measurements	0	0.0	0	0.0	0.0
Other	0	0.0	0	0.0	0.0
Not performed	21	75.0	11	84.6	78.0
Not known	1	3.6	0	0.0	2.4
No answer	1	3.6	0	0.0	2.4

QUESTION 4.27
 HAVE THE CABLES ON THIS BRIDGE (OR ANY OF
 THEIR COMPONENTS) BEEN REPAIRED?

	U.S.	% U.S.	Canada	% Canada	% Total
Yes	8	28.6	4	30.8	29.3
No	19	67.9	9	69.2	68.3
Not known	0	0.0	0	0.0	0.0
No answer	1	3.6	0	0.0	2.4

QUESTION 4.28
 HAS THE SHEATHING BEEN PARTIALLY REMOVED ON
 ANY OF THE CABLES TO EXAMINE CONDITION OF
 GROUT (IF APPLICABLE) AND/OR THE MTE?

	U.S.	% U.S.	Canada	% Canada	% Total
Yes	3	10.7	0	0.0	7.3
No	20	71.4	5	38.5	61.0
Not known	1	3.6	0	0.0	2.4
Not applicable	3	10.7	8	61.5	26.8
No answer	1	3.6	0	0.0	2.4

QUESTION 4.29
 CAN THE STRANDS OR CABLES BE
 REPLACED IF NEEDED?

	U.S.	% U.S.	Canada	% Canada	% Total
Yes	22	78.6	8	61.5	73.2
No	1	3.6	2	15.4	7.3
Not known	4	14.3	3	23.1	17.1
No answer	1	3.6	0	0.0	2.4

QUESTION 4.30
 DO YOU HAVE AN INSPECTION AND MAINTENANCE
 MANUAL FOR THIS BRIDGE?

	U.S.	% U.S.	Canada	% Canada	% Total
Yes	20	71.4	1	7.7	51.2
No	6	21.4	12	92.3	43.9
Not known	0	0.0	0	0.0	0.0
No answer	2	7.1	0	0.0	4.9

QUESTION 5
 BASED ON YOUR EXPERIENCE AND IN GENERAL, DO
 YOU BELIEVE THAT THE CURRENT INSPECTION,
 TESTING, MONITORING, AND REPAIR METHODS
 AVAILABLE TO YOU FOR STAY CABLES ARE
 EFFECTIVE AND ADEQUATE?

	U.S.	% U.S.	Canada	% Canada	% Total
Yes	11	39.3	12	92.3	56.1
No	8	28.6	0	0.0	19.5
Not known	9	32.1	1	7.7	24.4

QUESTION 10
 DO YOU BELIEVE THAT AN UP-TO-DATE RESOURCE
 SUCH AS A NATIONAL DATABASE OF INFORMATION
 ON STAY CABLE INSPECTION METHODS, REPAIRS,
 AND TESTING WOULD BE A USEFUL TOOL?

	U.S.	% U.S.	Canada	% Canada	% Total
Yes	25	89.3	12	92.3	90.2
No	0	0.0	0	0.0	0.0
Not known	3	10.7	0	0.0	7.3

APPENDIX C

Responses to Questionnaire

NCHRP SYNTHESIS TOPIC 35-07—INSPECTION AND MAINTENANCE OF BRIDGE STAY CABLE SYSTEMS

Cochrane Africatown
Alabama

Questionnaire Results
Survey performed in 2004

Cochrane Africatown

State/Province: *Alabama*

Agency: *Alabama DOT*

Respondent: *Fred Conway*

Span Length: *780 ft*

Year Built: *1991*

Q4-4: Type of main tension element (MTE)?

seven-wire steel strand

Q4-5: Coating/treatment on main tension element within free length of cable?

bare

Q4-6: Are the coatings/treatments on main tension element discontinued or removed within the anchorage zone?

N/A

Q4-7: Type of grout used?

cement–water admixtures

Q4-8: Are filler materials used in the anchorage zone?

yes, other

Q4-9: Type of anchorage?

conical socket with wedges

Q4-10: Do cables go over “saddles” on the pylons?

no

Q4-11: Type of cable sheathing used?

HDPE with PVF Tedlar tape

Q4-12: Have rain–wind-induced cable vibrations been observed on this bridge?

yes

Q4-13: Have MTE corrosion problems been noted?

no

Q4-14: Do cables have neoprene rings near the top and bottom anchorages?

yes

Q4-15: If there are neoprene rings on the cables; have there been any reports of movements of the rings out of their positions?

yes—due to loosening of retainers, and yes—due to shearing off of retainers

Q4-16: Has moisture been found in any of the internal components of stay cables such as the bottom anchorage areas?

yes

Q4-17: Has fatigue of MTE or other components of stay cables been observed?

no

Q4-18: Do the cables have viscous dampers installed at deck or tower levels?

yes—retrofitted to correct vibrations

Q4-19: Do the cables have cross cables installed between them?

no

Q4-20: Do cables have other dampers (other than viscous or neoprene rings) to control vibrations?

no

Q4-21: Has cracking of the cable sheathing or sheathing connections been noted?

no

Q4-22: Has cracking or misalignment of the guide pipes been noted?

yes—misalignment

Q4-23: If there is protective tape wrapped around the cable sheathing; have there been reports of deterioration of the tape?

yes—minor damage

Q4-24: Have any problems associated with neoprene boots been noted?

yes

Q4-25: Types of non-destructive tests that any of the cables on this bridge have been subjected to?

ultrasonic and vibration-based force measurements

Q4-26: Types of sensor-based, long-term monitoring performed on the cables?

vibration monitoring

Q4-27: Have the cables on this bridge (or any of their components) been repaired?

NCHRP SYNTHESIS TOPIC 35-07—INSPECTION AND MAINTENANCE OF BRIDGE STAY CABLE SYSTEMS

Cochrane Africatown
Alabama

Questionnaire Results
Survey performed in 2004

yes—some neoprene boots were replaced

Q4-28: Has the sheathing been partially removed on any of the cables to examine condition of grout (if applicable) and/or the MTE?

yes—thorough inspection performed. Selected cables were opened up where voids in grout were detected

Q4-29: Can the strands or cables be replaced if needed?

yes—individual strands cannot be replaced but an entire stay can be replaced

Q4-30: Do you have an inspection and maintenance manual for this bridge?

yes

Q5: Based on your experience and in general, do you believe that the current inspection, testing, monitoring, and repair methods available to you for stay cables are effective and adequate?

yes

Q6: Please comment on the effectiveness of any non-destructive test methods for inspections of stay cables that you may be familiar with. These methods include (but are not limited to) ultrasonic testing, magnetic inspections, laser-based force measurements, X-ray imaging, etc. If possible, please comment on issues such as practicality, cost, duration, impact on traffic, and any other factors that you consider important

Several non-destructive tests were run after an extreme oscillation event. Practically all the above were performed to determine if there was any loss of force in the stays. Geometric, physical and visual tests were performed. The only discoveries were deficiencies in the original construction which were corrected

Q7: Please comment on the effectiveness of any cable vibration control measures that you may be familiar with. Examples include installation of cross cables, viscous dampers, neoprene rings, etc.

We realigned stay pipes and replaced neoprene rings and keeper rings. Also external hydraulic dampers were installed on the longer stays

Q8: Please comment on the effectiveness of any sensor-based, long-term monitoring systems for stay cables that you may be familiar with. Examples include acoustic monitoring, vibration monitoring, force measurements, strain measurements, etc.

Check with A.G. Lichtenstein

Q9: What would you recommend that the cable suppliers incorporate into their systems to make cables more accessible and inspectable?

Provide access on inside and outside of tower anchorage.

Q10: Do you believe that an up-to-date resource such as a national database of information on stay cable inspection methods, repairs, and testing would be a useful tool?

not known

Q11: What do you see as the single most important problem in stay cable maintenance?

Stay anchors. (Access and rain–wind-induced oscillation.)

Q12: Please comment on any other methods for inspections, testing, monitoring, and repair of stay cable (including conventional methods) that you have found beneficial and are not listed above.

no answer

Additional comments?

NCHRP SYNTHESIS TOPIC 35-07—INSPECTION AND MAINTENANCE OF BRIDGE STAY CABLE SYSTEMS

Sitka Harbor Bridge Sitka, Alaska
Alaska

Questionnaire Results
Survey performed in 2004

**Sitka Harbor Bridge, Sitka,
Alaska**

State/Province: *Alaska*

Agency: *Alaska DOT*

Respondent: *Gary Scarbrough*

Span Length: *450 ft*

Year Built: *1970*

Q4-4: Type of main tension element (MTE)?

other—galvanized bridge strand

Q4-5: Coating/treatment on main tension element within free length of cable?

galvanized steel

Q4-6: Are the coatings/treatments on main tension element discontinued or removed within the anchorage zone?

not known

Q4-7: Type of grout used?

not known

Q4-8: Are filler materials used in the anchorage zone?

yes—other, liquid polymer sealer

Q4-9: Type of anchorage?

conical socket with wedges

Q4-10: Do cables go over “saddles” on the pylons?

no

Q4-11: Type of cable sheathing used?

no sheathing

Q4-12: Have rain–wind-induced cable vibrations been observed on this bridge?

not known

Q4-13: Have MTE corrosion problems been noted?

no

Q4-14: Do cables have neoprene rings near the top and bottom anchorages?

no

Q4-15: If there are neoprene rings on the cables; have there been any reports of movements of the rings out of their positions?

not applicable

Q4-16: Has moisture been found in any of the internal components of stay cables such as the bottom anchorage areas?

yes—area around each cable was filled with grease

Q4-17: Has fatigue of MTE or other components of stay cables been observed?

no

Q4-18: Do the cables have viscous dampers installed at deck or tower levels?

no

Q4-19: Do the cables have cross cables installed between them?

no

Q4-20: Do cables have other dampers (other than viscous or neoprene rings) to control vibrations?

no

Q4-21: Has cracking of the cable sheathing or sheathing connections been noted?

not applicable

Q4-22: Has cracking or misalignment of the guide pipes been noted?

not known

Q4-23: If there is protective tape wrapped around the cable sheathing; have there been reports of deterioration of the tape?

not applicable

Q4-24: Have any problems associated with neoprene boots been noted?

no

Q4-25: Types of non-destructive tests that any of the cables on this bridge have been subjected to?

vibration-based force measurements

Q4-26: Types of sensor-based, long-term monitoring performed on the cables?

not performed

Q4-27: Have the cables on this bridge (or any of their components) been repaired?

NCHRP SYNTHESIS TOPIC 35-07—INSPECTION AND MAINTENANCE OF BRIDGE STAY CABLE SYSTEMS

Sitka Harbor Bridge Sitka, Alaska
Alaska

Questionnaire Results
Survey performed in 2004

no—during mid-1990s cables were removed, inspected, and replaced after no defects observed.

Q4-28: Has the sheathing been partially removed on any of the cables to examine condition of grout (if applicable) and/or the MTE?

not applicable

Q4-29: Can the strands or cables be replaced if needed?

yes

Q4-30: Do you have an inspection and maintenance manual for this bridge?

no

Q5: Based on your experience and in general, do you believe that the current inspection, testing, monitoring, and repair methods available to you for stay cables are effective and adequate?

not known—cables on both bridges were inspected during the mid-1990s. Cables on Captain William Moore were replaced due to an upgrade of the structure. Cables on the Sitka Harbor Bridge were removed, inspected, and reinstalled. No problems were reported with any of the cables during the mid-1990 inspection.

Q6: Please comment on the effectiveness of any non-destructive test methods for inspections of stay cables that you may be familiar with. These methods include (but are not limited to) ultrasonic testing, magnetic

inspections, laser-based force measurements, X-ray imaging, etc. If possible, please comment on issues such as practicality, cost, duration, impact on traffic, and any other factors that you consider important.

The fundamental frequency of the cables was recorded. Alaska DOT&PF will monitor the cables and attempt to determine if the fundamental frequency of the cables has changed.

Q7: Please comment on the effectiveness of any cable vibration control measures that you may be familiar with. Examples include installation of cross cables, viscous dampers, neoprene rings, etc.

N/A

Q8: Please comment on the effectiveness of any sensor-based, long-term monitoring systems for stay cables that you may be familiar with. Examples include acoustic monitoring, vibration monitoring, force measurements, strain measurements, etc.

N/A

Q9: What would you recommend that the cable suppliers incorporate into their systems to make cables more accessible and inspectable?

N/A

Q10: Do you believe that an up-to-date resource such as a national database of information on stay cable inspection methods, repairs, and testing would be a useful tool?

yes

Q11: What do you see as the single most important problem in stay cable maintenance?

Access to upper cable anchorage

Q12: Please comment on any other methods for inspections, testing, monitoring, and repair of stay cable (including conventional methods) that you have found beneficial and are not listed above.

N/A

Additional comments?

no answer

NCHRP SYNTHESIS TOPIC 35-07—INSPECTION AND MAINTENANCE OF BRIDGE STAY CABLE SYSTEMS

*Captain William Moore Bridge, Skagway
Alaska*

*Questionnaire Results
Survey performed in 2004*

***Captain William Moore Bridge,
Skagway***

State/Province: *Alaska*

Agency: *Alaska DOT*

Respondent: *Gary Scarbrough*

Span Length: *300 ft*

Year Built: *1975*

Q4-4: Type of main tension element (MTE)?
other—ASTM Desig A586-86

Q4-5: Coating/treatment on main tension element within free length of cable?
galvanized steel

Q4-6: Are the coatings/treatments on main tension element discontinued or removed within the anchorage zone?
not known

Q4-7: Type of grout used?
not known

Q4-8: Are filler materials used in the anchorage zone?
yes, grease

Q4-9: Type of anchorage?
conical socket with wedges

Q4-10: Do cables go over “saddles” on the pylons?
no

Q4-11: Type of cable sheathing used?
no sheathing

Q4-12: Have rain–wind-induced cable vibrations been observed on this bridge?
not known

Q4-13: Have MTE corrosion problems been noted?
no

Q4-14: Do cables have neoprene rings near the top and bottom anchorages?
no

Q4-15: If there are neoprene rings on the cables; have there been any reports of movements of the rings out of their positions?
not applicable

Q4-16: Has moisture been found in any of the internal components of stay cables such as the bottom anchorage areas?
yes—area around each cable was filled with grease.

Q4-17: Has fatigue of MTE or other components of stay cables been observed?
no

Q4-18: Do the cables have viscous dampers installed at deck or tower levels?
no

Q4-19: Do the cables have cross cables installed between them?

no

Q4-20: Do cables have other dampers (other than viscous or neoprene rings) to control vibrations?
no

Q4-21: Has cracking of the cable sheathing or sheathing connections been noted?
not applicable

Q4-22: Has cracking or misalignment of the guide pipes been noted?
not known

Q4-23: If there is protective tape wrapped around the cable sheathing; have there been reports of deterioration of the tape?
not applicable

Q4-24: Have any problems associated with neoprene boots been noted?
no

Q4-25: Types of non-destructive tests that any of the cables on this bridge have been subjected to?
vibration-based force measurements

Q4-26: Types of sensor-based, long-term monitoring performed on the cables?
not performed

Q4-27: Have the cables on this bridge (or any of their components) been repaired?

NCHRP SYNTHESIS TOPIC 35-07—INSPECTION AND MAINTENANCE OF BRIDGE STAY CABLE SYSTEMS

*Captain William Moore Bridge, Skagway
Alaska*

*Questionnaire Results
Survey performed in 2004*

Bridge redesigned for higher load capacity. New cables were installed during mid-1990s.

Q4-28: Has the sheathing been partially removed on any of the cables to examine condition of grout (if applicable) and/or the MTE?

not applicable

Q4-29: Can the strands or cables be replaced if needed?

yes

Q4-30: Do you have an inspection and maintenance manual for this bridge?

no

Q5: Based on your experience and in general, do you believe that the current inspection, testing, monitoring, and repair methods available to you for stay cables are effective and adequate?

not known—cables on both bridges were inspected during the mid-1990s. Cables on Captain William Moore were replaced due to an upgrade of the structure. Cables on the Sitka Harbor Bridge were removed, inspected, and reinstalled. No problems were reported with any of the cables during the mid-1990 inspection.

Q6: Please comment on the effectiveness of any non-destructive test methods for inspections of stay cables that you may be familiar with. These methods include (but are not limited to) ultrasonic testing, magnetic inspections, laser-based force measurements,

X-ray imaging, etc. If possible, please comment on issues such as practicality, cost, duration, impact on traffic, and any other factors that you consider important.

The fundamental frequency of the cables was recorded. Alaska DOT&PF will monitor the cables and attempt to determine if the fundamental frequency of the cables has changed.

Q7: Please comment on the effectiveness of any cable vibration control measures that you may be familiar with. Examples include installation of cross cables, viscous dampers, neoprene rings, etc.

N/A

Q8: Please comment on the effectiveness of any sensor-based, long-term monitoring systems for stay cables that you may be familiar with. Examples include acoustic monitoring, vibration monitoring, force measurements, strain measurements, etc.

N/A

Q9: What would you recommend that the cable suppliers incorporate into their systems to make cables more accessible and inspectable?

N/A

Q10: Do you believe that an up-to-date resource such as a national database of information on stay cable inspection methods, repairs, and testing would be a useful tool?

yes

Q11: What do you see as the single most important problem in stay cable maintenance?

Access to upper cable anchorage

Q12: Please comment on any other methods for inspections, testing, monitoring, and repair of stay cable (including conventional methods) that you have found beneficial and are not listed above.

N/A

Additional comments?

no answer

NCHRP SYNTHESIS TOPIC 35-07—INSPECTION AND MAINTENANCE OF BRIDGE STAY CABLE SYSTEMS

**Sacramento River (Meridian)
California**

**Questionnaire Results
Survey performed in 2004**

Sacramento River (Meridian)

State/Province: **California**

Agency: **Caltrans**

Respondent: **Erol C. Kaslan**

Span Length: **180 ft**

Year Built: **1977**

Q4-4: Type of main tension element (MTE)?
steel wire

Q4-5: Coating/treatment on main tension element within free length of cable?

galvanized steel

Q4-6: Are the coatings/treatments on main tension element discontinued or removed within the anchorage zone?

no

Q4-7: Type of grout used?

grout not used

Q4-8: Are filler materials used in the anchorage zone?

yes, grease

Q4-9: Type of anchorage?

other—main cables are swedged onto a steel conical threaded coupler that is attached to a threaded HS steel rod, which uses a spherical anchor socket and anchor nut to provide anchorage connection. This system appears to be uniquely designed.

Q4-10: Do cables go over “saddles” on the pylons?

yes

Q4-11: Type of cable sheathing used?

no sheathing

Q4-12: Have rain–wind-induced cable vibrations been observed on this bridge?

no

Q4-13: Have MTE corrosion problems been noted?

no

Q4-14: Do cables have neoprene rings near the top and bottom anchorages?

no

Q4-15: If there are neoprene rings on the cables; have there been any reports of movements of the rings out of their positions?

N/A

Q4-16: Has moisture been found in any of the internal components of stay cables such as the bottom anchorage areas?

not tested, not known

Q4-17: Has fatigue of MTE or other components of stay cables been observed?

no

Q4-18: Do the cables have viscous dampers installed at deck or tower levels?

no

Q4-19: Do the cables have cross cables installed between them?

no

Q4-20: Do cables have other dampers (other than viscous or neoprene rings) to control vibrations?

Cables utilize clamps near the saddles to retain separation of the cable groups—these may provide some unintentional damping.

Q4-21: Has cracking of the cable sheathing or sheathing connections been noted?

N/A

Q4-22: Has cracking or misalignment of the guide pipes been noted?

N/A

Q4-23: If there is protective tape wrapped around the cable sheathing; have there been reports of deterioration of the tape?

N/A

Q4-24: Have any problems associated with neoprene boots been noted?

The neoprene seals noted above that retain grease in the anchorage areas leak.

Q4-25: Types of non-destructive tests that any of the cables on this bridge have been subjected to?

X-ray; primary inspection method is VT. "MINAC" radiographic inspection was used once in 1989 to inspect the swedged

NCHRP SYNTHESIS TOPIC 35-07—INSPECTION AND MAINTENANCE OF BRIDGE STAY CABLE SYSTEMS

**Sacramento River (Meridian)
California**

**Questionnaire Results
Survey performed in 2004**

anchorage components as a demonstration of the technology.

Q4-26: Types of sensor-based, long-term monitoring performed on the cables?

not performed

Q4-27: Have the cables on this bridge (or any of their components) been repaired?

no

Q4-28: Has the sheathing been partially removed on any of the cables to examine condition of grout (if applicable) and/or the MTE?

N/A

Q4-29: Can the strands or cables be replaced if needed?

yes—as this swing bridge only fully utilizes the cables to support the spans in the open condition, cable replacement would be relatively straightforward.

Q4-30: Do you have an inspection and maintenance manual for this bridge?

no

Q5: Based on your experience and in general, do you believe that the current inspection, testing, monitoring, and repair methods available to you for stay cables are effective and adequate?

not known

Q6: Please comment on the effectiveness of any non-destructive test methods for

inspections of stay cables that you may be familiar with. These methods include (but are not limited to) ultrasonic testing, magnetic inspections, laser-based force measurements, X-ray imaging, etc. If possible, please comment on issues such as practicality, cost, duration, impact on traffic, and any other factors that you consider important.

Used radiographic testing once on this structure. It was costly and impractical, but did appear to give satisfactory results. Would not use this method for routine inspections on this bridge.

Q7: Please comment on the effectiveness of any cable vibration control measures that you may be familiar with. Examples include installation of cross cables, viscous dampers, neoprene rings, etc.

no answer

Q8: Please comment on the effectiveness of any sensor-based, long-term monitoring systems for stay cables that you may be familiar with. Examples include acoustic monitoring, vibration monitoring, force measurements, strain measurements, etc.

Acoustic monitoring appears to have great value and promise. Would recommend that this technology be fully developed.

Q9: What would you recommend that the cable suppliers incorporate into their systems to make cables more accessible and inspectable?

Fiber optic strain gauges and redundant systems

Q10: Do you believe that an up-to-date resource such as a national database of information on stay cable inspection methods, repairs, and testing would be a useful tool?

yes

Q11: What do you see as the single most important problem in stay cable maintenance?

Inspection and condition evaluation of anchorages

Q12: Please comment on any other methods for inspections, testing, monitoring, and repair of stay cable (including conventional methods) that you have found beneficial and are not listed above.

Engineering judgment and experience seem to prevail in determining appropriate inspection and maintenance strategies.

Additional comments?

NCHRP SYNTHESIS TOPIC 35-07—INSPECTION AND MAINTENANCE OF BRIDGE STAY CABLE SYSTEMS

Br. 1-902, SR1 over the Chesapeake and Delaware Canal, St. Georges, New Castle County, Delaware

**Questionnaire Results
Survey performed in 2004**

Delaware

Br. 1-902, SR-1 over the Chesapeake and Delaware Canal, St. Georges, New Castle County, Delaware

State/Province: **Delaware**
 Agency: **Delaware DOT**
 Respondent: **Douglas Finney**
 Span Length: **750 ft**
 Year Built: **1995**

Q4-4: Type of main tension element (MTE)?
seven-wire steel strand

Q4-5: Coating/treatment on main tension element within free length of cable?
bare

Q4-6: Are the coatings/treatments on main tension element discontinued or removed within the anchorage zone?
not applicable

Q4-7: Type of grout used?
cement–water admixtures

Q4-8: Are filler materials used in the anchorage zone?
yes, grout

Q4-9: Type of anchorage?
conical socket with wedges

Q4-10: Do cables go over “saddles” on the pylons?

yes

Q4-11: Type of cable sheathing used?
steel pipe

Q4-12: Have rain–wind-induced cable vibrations been observed on this bridge?
no

Q4-13: Have MTE corrosion problems been noted?

not known—moisture infiltration is suspected however, due to the limitations of available inspection methods; definitive evidence of corrosion is not available.

Q4-14: Do cables have neoprene rings near the top and bottom anchorages?
yes

Q4-15: If there are neoprene rings on the cables; have there been any reports of movements of the rings out of their positions?
yes—due to loosening of retainers; movement observed in outer neoprene ring of anchorage set. No retaining devices were present.

Q4-16: Has moisture been found in any of the internal components of stay cables such as the bottom anchorage areas?

not known—efflorescence from anchorages as well as protective pipe splice sleeves leads

inspectors to believe moisture is infiltrating the cable stay system.

Q4-17: Has fatigue of MTE or other components of stay cables been observed?
no

Q4-18: Do the cables have viscous dampers installed at deck or tower levels?
no

Q4-19: Do the cables have cross cables installed between them?
no

Q4-20: Do cables have other dampers (other than viscous or neoprene rings) to control vibrations?

no
Q4-21: Has cracking of the cable sheathing or sheathing connections been noted?

yes, sheathing—cracking of the steel protective pipe has been noted on the uppermost stay cable of the north pylon. Cracking has been attributed to the position of a construction grout vent hole at a high stress location.

Q4-22: Has cracking or misalignment of the guide pipes been noted?
no

Q4-23: If there is protective tape wrapped around the cable sheathing; have there been reports of deterioration of the tape?

NCHRP SYNTHESIS TOPIC 35-07—INSPECTION AND MAINTENANCE OF BRIDGE STAY CABLE SYSTEMS

Br. 1-902, SR1 over the Chesapeake and Delaware Canal, St. Georges, New Castle County, Delaware

*Questionnaire Results
Survey performed in 2004*

Delaware

not applicable—protective steel pipe is painted.

Q4-24: Have any problems associated with neoprene boots been noted?

yes—minor tearing of one neoprene boot has been observed.

Q4-25: Types of non-destructive tests that any of the cables on this bridge have been subjected to?

other—borescope has been utilized to view the guidepipe area of select cable stays for moisture, fatigue, deterioration, and corrosion. An attempt was made to remove select anchorage caps; however, grout inside the anchorage caps made removal difficult.

High-powered X-ray inspection of the cable stays was considered. This method has not been employed due to concerns for protection of the public and personnel during testing, access limitations, uncertainty of the results of such investigations due to the complicated geometry of the subject area.

Q4-26: Types of sensor-based, long-term monitoring performed on the cables?

not performed. Vibration monitoring equipment has been installed on the cable stays by the FHWA. However, this equipment is currently not operating and data are not available.

Q4-27: Have the cables on this bridge (or any of their components) been repaired?

yes—out of position neoprene dampers have been repositioned and set screws have been installed to secure the position of the outer neoprene damper rings on all cable stays.

Q4-28: Has the sheathing been partially removed on any of the cables to examine condition of grout (if applicable) and/or the MTE?

no—limited investigation of the cable stay grout has been performed via the open construction grout vents in the saddle pipe area of the cable stay.

Q4-29: Can the strands or cables be replaced if needed?

yes—The original design accounted for the replacement of the stay cables (one at a time).

Q4-30: Do you have an inspection and maintenance manual for this bridge?

yes

Q5: Based on your experience and in general, do you believe that the current inspection, testing, monitoring, and repair methods available to you for stay cables are effective and adequate?

no—use of the steel protective pipe limits the inspection methods available to investigate the condition of the stay cables.

Q6: Please comment on the effectiveness of any non-destructive test methods for inspections of stay cables that you may be familiar with. These methods include (but are

not limited to) ultrasonic testing, magnetic inspections, laser-based force measurements, X-ray imaging, etc. If possible, please comment on issues such as practicality, cost, duration, impact on traffic, and any other factors that you consider important.

The presence of the steel protective pipe limits the effectiveness of many available testing methods, particularly magnetic based methods. As noted above, X-ray imaging of the cable stays was considered and dismissed. Several concerns were encountered with this method including protection of public and working personnel during the exposure, access and holding the equipment at the higher elevations of the cable stay, and scheduling of the equipment. Interpretation of the image was also a concern. It is believed that the multiple materials (steel, grout, steel strand) that comprise the cable stays combined with the changing geometry would make interpretation of the image difficult and would not allow for an accurate understanding of the conditions. Our understanding is that the X-ray imaging would only be able to detect gross section loss of the stay and is not precise enough to discern the onset or early stages of corrosion. Finally, when the X-ray imaging method was considered, it only allowed a view of a discrete section of the cable stay as opposed to a global or "traveling" operation which would allow an investigation of the entire length of the cable stay. Implementation of laser-based cable stay force measurements are being

NCHRP SYNTHESIS TOPIC 35-07—INSPECTION AND MAINTENANCE OF BRIDGE STAY CABLE SYSTEMS

Br. 1-902, SR1 over the Chesapeake and Delaware Canal, St. Georges, New Castle County, Delaware

Questionnaire Results
Survey performed in 2004

Delaware

considered by the department to establish baseline force data for the cable stays.

Q7: Please comment on the effectiveness of any cable vibration control measures that you may be familiar with. Examples include installation of cross cables, viscous dampers, neoprene rings, etc.

The neoprene dampers of the C&D Canal Bridge appear to operating adequately, particularly since the repositioning and installation of set screws into the outer neoprene rings. Excessive vibrations of the stay cables have not been noted. No other cable stay damping systems are present on the bridge. Grout spalls have been observed in the grout bedding (cable stays saddle area) where the upper stays (13 thru 16) enter the pylon. This spalling has been attributed to minor vibrations of the stays.

Q8: Please comment on the effectiveness of any sensor-based, long-term monitoring systems for stay cables that you may be familiar with. Examples include acoustic monitoring, vibration monitoring, force measurements, strain measurements, etc.

The current sensor-based, long-term monitoring system installed on the bridge is not operable and therefore comment cannot be made. The department is considering the addition of force measurement (deck-based laser method) to the list of inspections items required for the bridge.

Q9: What would you recommend that the cable suppliers incorporate into their systems to make cables more accessible and inspectable?

We would recommend the development of individual strand monitoring capabilities, which encompass the strands from anchorage to anchorage.

Q10: Do you believe that an up-to-date resource such as a national database of information on stay cable inspection methods, repairs, and testing would be a useful tool?

yes

Q11: What do you see as the single most important problem in stay cable maintenance?

Effective corrosion barriers that do not interfere with the ability to adequately inspect and assess the health of the cable stay system on a regular interval and within practical means.

Q12: Please comment on any other methods for inspections, testing, monitoring, and repair of stay cable (including conventional methods) that you have found beneficial and are not listed above.

No answer

Additional comments?

Dame Point Bridge
Florida

Questionnaire Results
Survey performed in 2004

Dame Point Bridge

State/Province: **Florida**

Agency: **Florida DOT**

Respondent: **Rick Vallier**

Span Length: **1,300 ft**

Year Built: **1989**

Q4-4: Type of main tension element (MTE)?

steel bar or threadbar

Q4-5: Coating/treatment on main tension element within free length of cable?

epoxy-coated on outside only

Q4-6: Are the coatings/treatments on main tension element discontinued or removed within the anchorage zone?

not known

Q4-7: Type of grout used?

not known—a cement grout was used

Q4-8: Are filler materials used in the anchorage zone?

yes, grout

Q4-9: Type of anchorage?

wedges

Q4-10: Do cables go over “saddles” on the pylons?

no

Q4-11: Type of cable sheathing used?

steel pipe

Q4-12: Have rain–wind-induced cable vibrations been observed on this bridge?

no

Q4-13: Have MTE corrosion problems been noted?

no

Q4-14: Do cables have neoprene rings near the top and bottom anchorages?

no

Q4-15: If there are neoprene rings on the cables; have there been any reports of movements of the rings out of their positions?

N/A

Q4-16: Has moisture been found in any of the internal components of stay cables such as the bottom anchorage areas?

yes

Q4-17: Has fatigue of MTE or other components of stay cables been observed?

no

Q4-18: Do the cables have viscous dampers installed at deck or tower levels?

no

Q4-19: Do the cables have cross cables installed between them?

yes—from the beginning

Q4-20: Do cables have other dampers (other than viscous or neoprene rings) to control vibrations?

no

Q4-21: Has cracking of the cable sheathing or sheathing connections been noted?

yes—connections

Q4-22: Has cracking or misalignment of the guide pipes been noted?

no

Q4-23: If there is protective tape wrapped around the cable sheathing; have there been reports of deterioration of the tape?

N/A

Q4-24: Have any problems associated with neoprene boots been noted?

no

Q4-25: Types of non-destructive tests that any of the cables on this bridge have been subjected to?

not performed

Q4-26: Types of sensor-based, long-term monitoring performed on the cables?

not performed

Q4-27: Have the cables on this bridge (or any of their components) been repaired?

no

NCHRP SYNTHESIS TOPIC 35-07—INSPECTION AND MAINTENANCE OF BRIDGE STAY CABLE SYSTEMS

**Dame Point Bridge
Florida**

**Questionnaire Results
Survey performed in 2004**

Q4-28: Has the sheathing been partially removed on any of the cables to examine condition of grout (if applicable) and/or the MTE?

no

Q4-29: Can the strands or cables be replaced if needed?

no

Q4-30: Do you have an inspection and maintenance manual for this bridge?

yes

Q5: Based on your experience and in general, do you believe that the current inspection, testing, monitoring, and repair methods available to you for stay cables are effective and adequate?

not known

Q6: Please comment on the effectiveness of any non-destructive test methods for inspections of stay cables that you may be familiar with. These methods include (but are not limited to) ultrasonic testing, magnetic inspections, laser-based force measurements, X-ray imaging, etc. If possible, please comment on issues such as practicality, cost, duration, impact on traffic, and any other factors that you consider important.

Non-destructive testing is needed to determine the condition of tension bars inside the steel casing of the cables.

Q7: Please comment on the effectiveness of any cable vibration control measures that you

may be familiar with. Examples include installation of cross cables, viscous dampers, neoprene rings, etc.

Cross cables are installed on the bridge and from time to time they sag and need to be retightened.

Q8: Please comment on the effectiveness of any sensor-based, long-term monitoring systems for stay cables that you may be familiar with. Examples include acoustic monitoring, vibration monitoring, force measurements, strain measurements, etc.

none

Q9: What would you recommend that the cable suppliers incorporate into their systems to make cables more accessible and inspectable?

Not familiar with this

Q10: Do you believe that an up-to-date resource such as a national database of information on stay cable inspection methods, repairs, and testing would be a useful tool?

yes

Q11: What do you see as the single most important problem in stay cable maintenance?

Accessibility for inspection and maintenance

Q12: Please comment on any other methods for inspections, testing, monitoring, and repair of stay cable (including conventional methods) that you have found beneficial and are not listed above.

Man-lift truck

Additional comments?

NCHRP SYNTHESIS TOPIC 35-07—INSPECTION AND MAINTENANCE OF BRIDGE STAY CABLE SYSTEMS

*Talmadge Memorial Bridge, Savannah
Georgia*

*Questionnaire Results
Survey performed in 2004*

***Talmadge Memorial Bridge,
Savannah***

State/Province: *Georgia*

Agency: *Georgia DOT*

Respondent: *Paul V. Liles, Jr.*

Span Length: *1,100 ft*

Year Built: *1991*

Q4-4: Type of main tension element (MTE)?

seven-wire steel strand

Q4-5: Coating/treatment on main tension element within free length of cable?

bare

Q4-6: Are the coatings/treatments on main tension element discontinued or removed within the anchorage zone?

N/A

Q4-7: Type of grout used?

cement–water

Q4-8: Are filler materials used in the anchorage zone?

yes, other—steel shot and epoxy

Q4-9: Type of anchorage?

other—American Stronghold system

Q4-10: Do cables go over “saddles” on the pylons?

no

Q4-11: Type of cable sheathing used?

HDPE with PVF Tedlar tape

Q4-12: Have rain–wind-induced cable vibrations been observed on this bridge?

yes

Q4-13: Have MTE corrosion problems been noted?

no

Q4-14: Do cables have neoprene rings near the top and bottom anchorages?

yes

Q4-15: If there are neoprene rings on the cables; have there been any reports of movements of the rings out of their positions?

yes—due to loosening of retainers, and yes—due to shearing off of retainers

Q4-16: Has moisture been found in any of the internal components of stay cables such as the bottom anchorage areas?

no

Q4-17: Has fatigue of MTE or other components of stay cables been observed?

no

Q4-18: Do the cables have viscous dampers installed at deck or tower levels?

no

Q4-19: Do the cables have cross cables installed between them?

no

Q4-20: Do cables have other dampers (other than viscous or neoprene rings) to control vibrations?

no

Q4-21: Has cracking of the cable sheathing or sheathing connections been noted?

no

Q4-22: Has cracking or misalignment of the guide pipes been noted?

yes—cracking

Q4-23: If there is protective tape wrapped around the cable sheathing; have there been reports of deterioration of the tape?

no

Q4-24: Have any problems associated with neoprene boots been noted?

no

Q4-25: Types of non-destructive tests that any of the cables on this bridge have been subjected to?

vibration-based force measurements

Q4-26: Types of sensor-based, long-term monitoring performed on the cables?

not performed

Q4-27: Have the cables on this bridge (or any of their components) been repaired?

no

NCHRP SYNTHESIS TOPIC 35-07—INSPECTION AND MAINTENANCE OF BRIDGE STAY CABLE SYSTEMS

*Talmadge Memorial Bridge, Savannah
Georgia*

*Questionnaire Results
Survey performed in 2004*

Q4-28: Has the sheathing been partially removed on any of the cables to examine condition of grout (if applicable) and/or the MTE?

yes—some removal and inspection was done in 2002. Grout was found to be satisfactory.

Q4-29: Can the strands or cables be replaced if needed?

yes

Q4-30: Do you have an inspection and maintenance manual for this bridge?

yes

Q5: Based on your experience and in general, do you believe that the current inspection, testing, monitoring, and repair methods available to you for stay cables are effective and adequate?

yes

Q6: Please comment on the effectiveness of any non-destructive test methods for inspections of stay cables that you may be familiar with. These methods include (but are not limited to) ultrasonic testing, magnetic inspections, laser-based force measurements, X-ray imaging, etc. If possible, please comment on issues such as practicality, cost, duration, impact on traffic, and any other factors that you consider important.

Laser-based force measurements will give results that will indicate if a cable is deviating from the trending values of the other cables. It may not give you an accurate value of the

force in a cable. It is relatively easy and inexpensive to perform.

Q7: Please comment on the effectiveness of any cable vibration control measures that you may be familiar with. Examples include installation of cross cables, viscous dampers, neoprene rings, etc.

These methods are all effective in controlling free vibrations of the cables. Helical strakes formed in the cable neoprene sheathing are also effective.

Q8: Please comment on the effectiveness of any sensor-based, long-term monitoring systems for stay cables that you may be familiar with. Examples include acoustic monitoring, vibration monitoring, force measurements, strain measurements, etc.

These are all effective but they are generally expensive and have not been used on Georgia's bridges.

Q9: What would you recommend that the cable suppliers incorporate into their systems to make cables more accessible and inspectable?

For non-box bridges, an inspection traveller should be installed on the cable-stayed bridge. This should be done by the owner.

Q10: Do you believe that an up-to-date resource such as a national database of information on stay cable inspection methods, repairs, and testing would be a useful tool?

yes

Q11: What do you see as the single most important problem in stay cable maintenance?

Access to the cable anchorages

Q12: Please comment on any other methods for inspections, testing, monitoring, and repair of stay cable (including conventional methods) that you have found beneficial and are not listed above.

Television endoscope type cameras for access to guide pipes at bridge deck level are helpful.

Additional comments?

Sidney Lanier Bridge, Brunswick
Georgia

Questionnaire Results
Survey performed in 2004

**Sidney Lanier Bridge,
Brunswick**

State/Province: *Georgia*

Agency: *Georgia DOT*

Respondent: *Paul V. Liles, Jr.*

Span Length: *1,250 ft*

Year Built: *2003*

Q4-4: Type of main tension element (MTE)?

seven-wire steel strand

Q4-5: Coating/treatment on main tension element within free length of cable?

bare

Q4-6: Are the coatings/treatments on main tension element discontinued or removed within the anchorage zone?

N/A

Q4-7: Type of grout used?

cement–water

Q4-8: Are filler materials used in the anchorage zone?

yes, grout

Q4-9: Type of anchorage?

conical socket with wedges

Q4-10: Do cables go over “saddles” on the pylons?

no

Q4-11: Type of cable sheathing used?

HDPE with PVF Tedlar tape

Q4-12: Have rain–wind-induced cable vibrations been observed on this bridge?

no

Q4-13: Have MTE corrosion problems been noted?

no

Q4-14: Do cables have neoprene rings near the top and bottom anchorages?

yes

Q4-15: If there are neoprene rings on the cables; have there been any reports of movements of the rings out of their positions?

no, not known

Q4-16: Has moisture been found in any of the internal components of stay cables such as the bottom anchorage areas?

no

Q4-17: Has fatigue of MTE or other components of stay cables been observed?

no

Q4-18: Do the cables have viscous dampers installed at deck or tower levels?

no

Q4-19: Do the cables have cross cables installed between them?

no

Q4-20: Do cables have other dampers (other than viscous or neoprene rings) to control vibrations?

no

Q4-21: Has cracking of the cable sheathing or sheathing connections been noted?

no

Q4-22: Has cracking or misalignment of the guide pipes been noted?

no

Q4-23: If there is protective tape wrapped around the cable sheathing; have there been reports of deterioration of the tape?

no

Q4-24: Have any problems associated with neoprene boots been noted?

no

Q4-25: Types of non-destructive tests that any of the cables on this bridge have been subjected to?

not performed

Q4-26: Types of sensor-based, long-term monitoring performed on the cables?

not performed

Q4-27: Have the cables on this bridge (or any of their components) been repaired?

no

NCHRP SYNTHESIS TOPIC 35-07—INSPECTION AND MAINTENANCE OF BRIDGE STAY CABLE SYSTEMS

*Sidney Lanier Bridge, Brunswick
Georgia*

*Questionnaire Results
Survey performed in 2004*

Q4-28: Has the sheathing been partially removed on any of the cables to examine condition of grout (if applicable) and/or the MTE?

no answer

Q4-29: Can the strands or cables be replaced if needed?

yes

Q4-30: Do you have an inspection and maintenance manual for this bridge?

yes

Q5: Based on your experience and in general, do you believe that the current inspection, testing, monitoring, and repair methods available to you for stay cables are effective and adequate?

yes

Q6: Please comment on the effectiveness of any non-destructive test methods for inspections of stay cables that you may be familiar with. These methods include (but are not limited to) ultrasonic testing, magnetic inspections, laser-based force measurements, X-ray imaging, etc. If possible, please comment on issues such as practicality, cost, duration, impact on traffic, and any other factors that you consider important.

Laser-based force measurements will give results that will indicate if a cable is deviating from the trending values of the other cables. It may not give you an accurate value of the

force in a cable. It is relatively easy and inexpensive to perform.

Q7: Please comment on the effectiveness of any cable vibration control measures that you may be familiar with. Examples include installation of cross cables, viscous dampers, neoprene rings, etc.

These methods are all effective in controlling free vibrations of the cables. Helical strakes formed in the cable neoprene sheathing are also effective

Q8: Please comment on the effectiveness of any sensor-based, long-term monitoring systems for stay cables that you may be familiar with. Examples include acoustic monitoring, vibration monitoring, force measurements, strain measurements, etc.

These are all effective but they are generally expensive and have not been used on Georgia's bridges

Q9: What would you recommend that the cable suppliers incorporate into their systems to make cables more accessible and inspectable?

For non-box bridges, an inspection traveller should be installed on the cable-stayed bridge. The should be done by the owner.

Q10: Do you believe that an up-to-date resource such as a national database of information on stay cable inspection methods, repairs, and testing would be a useful tool?

yes

Q11: What do you see as the single most important problem in stay cable maintenance?

Access to the cable anchorages

Q12: Please comment on any other methods for inspections, testing, monitoring, and repair of stay cable (including conventional methods) that you have found beneficial and are not listed above.

Television endoscope type cameras for access to guide pipes at bridge deck levelares helpful.

Additional comments?

NCHRP SYNTHESIS TOPIC 35-07—INSPECTION AND MAINTENANCE OF BRIDGE STAY CABLE SYSTEMS

**Quincy Bayview Bridge at Quincy, IL
Illinois**

**Questionnaire Results
Survey performed in 2004**

Quincy Bayview Bridge at Quincy, IL

State/Province: **Illinois**

Agency: **Illinois DOT**

Respondent: **Carl Puzey**

Span Length: **900 ft**

Year Built: **1986**

Q4-4: Type of main tension element (MTE)?
seven-wire steel strand

Q4-5: Coating/treatment on main tension element within free length of cable?

epoxy-coated on outside only

Q4-6: Are the coatings/treatments on main tension element discontinued or removed within the anchorage zone?

not known

Q4-7: Type of grout used?

not known

Q4-8: Are filler materials used in the anchorage zone?

not known

Q4-9: Type of anchorage?

not known

Q4-10: Do cables go over “saddles” on the pylons?

no

Q4-11: Type of cable sheathing used?

UV-resistant HDPE contract in 2003 to wrap cables with elastomeric wrap

Q4-12: Have rain–wind-induced cable vibrations been observed on this bridge?

no

Q4-13: Have MTE corrosion problems been noted?

not known

Q4-14: Do cables have neoprene rings near the top and bottom anchorages?

yes

Q4-15: If there are neoprene rings on the cables; have there been any reports of movements of the rings out of their positions?

no, not known

Q4-16: Has moisture been found in any of the internal components of stay cables such as the bottom anchorage areas?

yes

Q4-17: Has fatigue of MTE or other components of stay cables been observed?

no

Q4-18: Do the cables have viscous dampers installed at deck or tower levels?

no

Q4-19: Do the cables have cross cables installed between them?

no

Q4-20: Do cables have other dampers (other than viscous or neoprene rings) to control vibrations?

no

Q4-21: Has cracking of the cable sheathing or sheathing connections been noted?

yes, sheathing

Q4-22: Has cracking or misalignment of the guide pipes been noted?

no

Q4-23: If there is protective tape wrapped around the cable sheathing; have there been reports of deterioration of the tape?

N/A—see comment above about wrapping in 2003

Q4-24: Have any problems associated with neoprene boots been noted?

no

Q4-25: Types of non-destructive tests that any of the cables on this bridge have been subjected to?

not performed

Q4-26: Types of sensor-based, long-term monitoring performed on the cables?

acoustic wire break detection

Q4-27: Have the cables on this bridge (or any of their components) been repaired?

NCHRP SYNTHESIS TOPIC 35-07—INSPECTION AND MAINTENANCE OF BRIDGE STAY CABLE SYSTEMS

*Quincy Bayview Bridge at Quincy, IL
Illinois*

*Questionnaire Results
Survey performed in 2004*

yes—previous intermittent wrapping. See comment above about complete wrapping in 2003.

Q4-28: Has the sheathing been partially removed on any of the cables to examine condition of grout (if applicable) and/or the MTE?

no

Q4-29: Can the strands or cables be replaced if needed?

yes

Q4-30: Do you have an inspection and maintenance manual for this bridge?

no

Q5: Based on your experience and in general, do you believe that the current inspection, testing, monitoring, and repair methods available to you for stay cables are effective and adequate?

no

Q6: Please comment on the effectiveness of any non-destructive test methods for inspections of stay cables that you may be familiar with. These methods include (but are not limited to) ultrasonic testing, magnetic inspections, laser-based force measurements, X-ray imaging, etc. If possible, please comment on issues such as practicality, cost, duration, impact on traffic, and any other factors that you consider important.

no answer

Q7: Please comment on the effectiveness of any cable vibration control measures that you may be familiar with. Examples include installation of cross cables, viscous dampers, neoprene rings, etc.

Cross cables on the Clark Bridge have been effective.

Q8: Please comment on the effectiveness of any sensor-based, long-term monitoring systems for stay cables that you may be familiar with. Examples include acoustic monitoring, vibration monitoring, force measurements, strain measurements, etc.

An acoustic monitoring system was installed (approximately a year and a half ago) on one-fourth of the stays of the Quincy Bayview Bridge. This was done due to concern over water in the cable anchorages and to evaluate the technology. The system appears to be functioning properly and so far has provided information on one "event" that has been classified as a wire break.

Q9: What would you recommend that the cable suppliers incorporate into their systems to make cables more accessible and inspectable?

no answer

Q10: Do you believe that an up-to-date resource such as a national database of information on stay cable inspection methods, repairs, and testing would be a useful tool?

yes

Q11: What do you see as the single most important problem in stay cable maintenance?

Uncertainty of cable condition and anchorages

Q12: Please comment on any other methods for inspections, testing, monitoring, and repair of stay cable (including conventional methods) that you have found beneficial and are not listed above.

no answer

Additional comments?

NCHRP SYNTHESIS TOPIC 35-07—INSPECTION AND MAINTENANCE OF BRIDGE STAY CABLE SYSTEMS

Clark Bridge at Alton, IL
Illinois

Questionnaire Results
Survey performed in 2004

Clark Bridge at Alton, IL

State/Province: *Illinois*
Agency: *Illinois DOT*
Respondent: *Carl Puzey*
Span Length: *756 ft*
Year Built: *1994*

Q4-4: Type of main tension element (MTE)?

seven-wire steel strand

Q4-5: Coating/treatment on main tension element within free length of cable?

*epoxy-coated on outside only—with grit**

Q4-6: Are the coatings/treatments on main tension element discontinued or removed within the anchorage zone?

*No, the ends of strands were sealed with flexible sealer and a flexible rubber cap.**

Q4-7: Type of grout used?

*Bulk non-shrink grout mixed on site**

Q4-8: Are filler materials used in the anchorage zone?

*yes—grout with sand**

Q4-9: Type of anchorage?

*conical socket with wedges**

Q4-10: Do cables go over “saddles” on the pylons?

yes

Q4-11: Type of cable sheathing used?

*HDPE**

Q4-12: Have rain–wind-induced cable vibrations been observed on this bridge?

yes—prior to installation of cross cables

Q4-13: Have MTE corrosion problems been noted?

no

Q4-14: Do cables have neoprene rings near the top and bottom anchorages?

yes

Q4-15: If there are neoprene rings on the cables; have there been any reports of movements of the rings out of their positions?

no, not known

Q4-16: Has moisture been found in any of the internal components of stay cables such as the bottom anchorage areas?

not known, some rust visible at a few anchorages

Q4-17: Has fatigue of MTE or other components of stay cables been observed?

no

Q4-18: Do the cables have viscous dampers installed at deck or tower levels?

no

Q4-19: Do the cables have cross cables installed between them?

yes—retrofitted to correct vibrations

Q4-20: Do cables have other dampers (other than viscous or neoprene rings) to control vibrations?

no

Q4-21: Has cracking of the cable sheathing or sheathing connections been noted?

not known

Q4-22: Has cracking or misalignment of the guide pipes been noted?

no

Q4-23: If there is protective tape wrapped around the cable sheathing; have there been reports of deterioration of the tape?

*yes—minor damage**

Q4-24: Have any problems associated with neoprene boots been noted?

no

Q4-25: Types of non-destructive tests that any of the cables on this bridge have been subjected to?

not performed

Q4-26: Types of sensor-based, long-term monitoring performed on the cables?

not performed

Q4-27: Have the cables on this bridge (or any of their components) been repaired?

no

NCHRP SYNTHESIS TOPIC 35-07—INSPECTION AND MAINTENANCE OF BRIDGE STAY CABLE SYSTEMS

**Clark Bridge at Alton, IL
Illinois**

**Questionnaire Results
Survey performed in 2004**

Q4-28: Has the sheathing been partially removed on any of the cables to examine condition of grout (if applicable) and/or the MTE?

no

Q4-29: Can the strands or cables be replaced if needed?

yes

Q4-30: Do you have an inspection and maintenance manual for this bridge?

yes, not included for security reasons

Q5: Based on your experience and in general, do you believe that the current inspection, testing, monitoring, and repair methods available to you for stay cables are effective and adequate?

no

Q6: Please comment on the effectiveness of any non-destructive test methods for inspections of stay cables that you may be familiar with. These methods include (but are not limited to) ultrasonic testing, magnetic inspections, laser-based force measurements, X-ray imaging, etc. If possible, please comment on issues such as practicality, cost, duration, impact on traffic, and any other factors that you consider important.

no answer

Q7: Please comment on the effectiveness of any cable vibration control measures that you may be familiar with. Examples include

installation of cross cables, viscous dampers, neoprene rings, etc.

Cross cables on the Clark Bridge have been effective.

Q8: Please comment on the effectiveness of any sensor-based, long-term monitoring systems for stay cables that you may be familiar with. Examples include acoustic monitoring, vibration monitoring, force measurements, strain measurements, etc.

An acoustic monitoring system was installed (approximately a year and a half ago) on one-fourth of the stays of the Quincy Bayview Bridge. This was done due to concern over water in the cable anchorages and to evaluate the technology. The system appears to be functioning properly and so far has provided information on one "event" that has been classified as a wire break.

Q9: What would you recommend that the cable suppliers incorporate into their systems to make cables more accessible and inspectable?

no answer

Q10: Do you believe that an up-to-date resource such as a national database of information on stay cable inspection methods, repairs, and testing would be a useful tool?

yes

Q11: What do you see as the single most important problem in stay cable maintenance?

Uncertainty of cable condition and anchorages

Q12: Please comment on any other methods for inspections, testing, monitoring, and repair of stay cable (including conventional methods) that you have found beneficial and are not listed above.

no answer

Additional comments?

*Answers provided subsequent to the initial submittal by Mr. Steve Putz, Illinois DOT.

NCHRP SYNTHESIS TOPIC 35-07—INSPECTION AND MAINTENANCE OF BRIDGE STAY CABLE SYSTEMS

46-03-7495 EBL
Indiana

Questionnaire Results
Survey performed in 2004

46-03-7495 EBL

State/Province: *Indiana*
Agency: *Indiana DOT*
Respondent: *Bill Dittrich*
Span Length: *466 ft*
Year Built: *1999*

Q4-4: Type of main tension element (MTE)?
seven-wire steel strand

Q4-5: Coating/treatment on main tension element within free length of cable?

I think they are bare??

Q4-6: Are the coatings/treatments on main tension element discontinued or removed within the anchorage zone?

not known

Q4-7: Type of grout used?
cement–water admixtures

Q4-8: Are filler materials used in the anchorage zone?

not known

Q4-9: Type of anchorage?
conical socket with wedges

Q4-10: Do cables go over “saddles” on the pylons?

no

Q4-11: Type of cable sheathing used?

polyethylene stay pipes

Q4-12: Have rain–wind-induced cable vibrations been observed on this bridge?

no

Q4-13: Have MTE corrosion problems been noted?

no

Q4-14: Do cables have neoprene rings near the top and bottom anchorages?

yes

Q4-15: If there are neoprene rings on the cables; have there been any reports of movements of the rings out of their positions?

no, not known

Q4-16: Has moisture been found in any of the internal components of stay cables such as the bottom anchorage areas?

not tested

Q4-17: Has fatigue of MTE or other components of stay cables been observed?

no

Q4-18: Do the cables have viscous dampers installed at deck or tower levels?

no

Q4-19: Do the cables have cross cables installed between them?

yes, from the beginning

Q4-20: Do cables have other dampers (other than viscous or neoprene rings) to control vibrations?

no

Q4-21: Has cracking of the cable sheathing or sheathing connections been noted?

no

Q4-22: Has cracking or misalignment of the guide pipes been noted?

no

Q4-23: If there is protective tape wrapped around the cable sheathing; have there been reports of deterioration of the tape?

N/A

Q4-24: Have any problems associated with neoprene boots been noted?

no

Q4-25: Types of non-destructive tests that any of the cables on this bridge have been subjected to?

not performed

Q4-26: Types of sensor-based, long-term monitoring performed on the cables?

not performed

Q4-27: Have the cables on this bridge (or any of their components) been repaired?

no

NCHRP SYNTHESIS TOPIC 35-07—INSPECTION AND MAINTENANCE OF BRIDGE STAY CABLE SYSTEMS

**46-03-7495 EBL
Indiana**

**Questionnaire Results
Survey performed in 2004**

Q4-28: Has the sheathing been partially removed on any of the cables to examine condition of grout (if applicable) and/or the MTE?

no

Q4-29: Can the strands or cables be replaced if needed?

not known—I would hope that they could be if needed.

Q4-30: Do you have an inspection and maintenance manual for this bridge?

yes

Q5: Based on your experience and in general, do you believe that the current inspection, testing, monitoring, and repair methods available to you for stay cables are effective and adequate?

no—We will be having these two bridges inspected and tested by a consultant in the next 1–2-year time frame. We are just beginning to get a good understanding of the possible problems that we may encounter on these bridges over the coming years.

Q6: Please comment on the effectiveness of any non-destructive test methods for inspections of stay cables that you may be familiar with. These methods include (but are not limited to) ultrasonic testing, magnetic inspections, laser-based force measurements, X-ray imaging, etc. If possible, please comment on issues such as practicality, cost, duration, impact on traffic, and any other factors that you consider important.

We have not yet done any testing on these two cable-stayed bridges, but probably will be doing so in the next 1–2 years.

Q7: Please comment on the effectiveness of any cable vibration control measures that you may be familiar with. Examples include installation of cross cables, viscous dampers, neoprene rings, etc.

The ones on the SR-46 bridge seem to be OK. There are also some on the new US-231 bridge over the Ohio River that we share with Kentucky (Kentucky is the lead state for this bridge). They seem to be OK also. However, I have not been at either of these bridges during bad weather.

Q8: Please comment on the effectiveness of any sensor-based, long-term monitoring systems for stay cables that you may be familiar with. Examples include acoustic monitoring, vibration monitoring, force measurements, strain measurements, etc.

Have not used any yet.

Q9: What would you recommend that the cable suppliers incorporate into their systems to make cables more accessible and inspectable?

??

Q10: Do you believe that an up-to-date resource such as a national database of information on stay cable inspection methods, repairs, and testing would be a useful tool?

yes

Q11: What do you see as the single most important problem in stay cable maintenance?

Inspection, access, testing, cost.

Q12: Please comment on any other methods for inspections, testing, monitoring, and repair of stay cable (including conventional methods) that you have found beneficial and are not listed above.

no answer

Additional comments?

NCHRP SYNTHESIS TOPIC 35-07—INSPECTION AND MAINTENANCE OF BRIDGE STAY CABLE SYSTEMS

I65-68-7910
Indiana

Questionnaire Results
Survey performed in 2004

I65-68-7910

State/Province: **Indiana**

Agency: **Indiana DOT**

Respondent: **Bill Dittrich**

Span Length: **197.5 ft**

Year Built: **1996**

Q4-4: Type of main tension element (MTE)?

seven-wire steel strand

Q4-5: Coating/treatment on main tension element within free length of cable?

I think they are bare??

Q4-6: Are the coatings/treatments on main tension element discontinued or removed within the anchorage zone?

not known

Q4-7: Type of grout used?

cement–water admixtures

Q4-8: Are filler materials used in the anchorage zone?

not known

Q4-9: Type of anchorage?

conical socket with wedges

Q4-10: Do cables go over “saddles” on the pylons?

no

Q4-11: Type of cable sheathing used?

polyethylene stay pipes with pressure-sensitive PVF tape

Q4-12: Have rain–wind-induced cable vibrations been observed on this bridge?

no

Q4-13: Have MTE corrosion problems been noted?

no

Q4-14: Do cables have neoprene rings near the top and bottom anchorages?

yes

Q4-15: If there are neoprene rings on the cables; have there been any reports of movements of the rings out of their positions?

no, not known

Q4-16: Has moisture been found in any of the internal components of stay cables such as the bottom anchorage areas?

not tested

Q4-17: Has fatigue of MTE or other components of stay cables been observed?

no

Q4-18: Do the cables have viscous dampers installed at deck or tower levels?

no

Q4-19: Do the cables have cross cables installed between them?

no

Q4-20: Do cables have other dampers (other than viscous or neoprene rings) to control vibrations?

no

Q4-21: Has cracking of the cable sheathing or sheathing connections been noted?

no

Q4-22: Has cracking or misalignment of the guide pipes been noted?

not applicable

Q4-23: If there is protective tape wrapped around the cable sheathing; have there been reports of deterioration of the tape?

no

Q4-24: Have any problems associated with neoprene boots been noted?

no

Q4-25: Types of non-destructive tests that any of the cables on this bridge have been subjected to?

not performed

Q4-26: Types of sensor-based, long-term monitoring performed on the cables?

not performed

Q4-27: Have the cables on this bridge (or any of their components) been repaired?

no

NCHRP SYNTHESIS TOPIC 35-07—INSPECTION AND MAINTENANCE OF BRIDGE STAY CABLE SYSTEMS

165-68-7910
Indiana

Questionnaire Results
Survey performed in 2004

Q4-28: Has the sheathing been partially removed on any of the cables to examine condition of grout (if applicable) and/or the MTE?

no

Q4-29: Can the strands or cables be replaced if needed?

not known—I would hope that they could be if needed.

Q4-30: Do you have an inspection and maintenance manual for this bridge?

yes

Q5: Based on your experience and in general, do you believe that the current inspection, testing, monitoring, and repair methods available to you for stay cables are effective and adequate?

no—We will be having these two bridges inspected and tested by a consultant in the next 1–2 year time frame. We are just beginning to get a good understanding of the possible problems that we may encounter on these bridges over the coming years.

Q6: Please comment on the effectiveness of any non-destructive test methods for inspections of stay cables that you may be familiar with. These methods include (but are not limited to) ultrasonic testing, magnetic inspections, laser-based force measurements, X-ray imaging, etc. If possible, please comment on issues such as practicality, cost, duration, impact on traffic, and any other factors that you consider important.

We have not yet done any testing on these two cable-stayed bridges, but probably will be doing so in the next 1–2 years.

Q7: Please comment on the effectiveness of any cable vibration control measures that you may be familiar with. Examples include installation of cross cables, viscous dampers, neoprene rings, etc.

The ones on the SR-46 bridge seem to be OK. There are also some on the new US-231 bridge over the Ohio River that we share with Kentucky (Kentucky is the lead state for this bridge). They seem to be OK also. However, I have not been at either of these bridges during bad weather.

Q8: Please comment on the effectiveness of any sensor-based, long-term monitoring systems for stay cables that you may be familiar with. Examples include acoustic monitoring, vibration monitoring, force measurements, strain measurements, etc.

Have not used any yet.

Q9: What would you recommend that the cable suppliers incorporate into their systems to make cables more accessible and inspectable?

??

Q10: Do you believe that an up-to-date resource such as a national database of information on stay cable inspection methods, repairs, and testing would be a useful tool?

yes

Q11: What do you see as the single most important problem in stay cable maintenance?

Inspection, access, testing, cost.

Q12: Please comment on any other methods for inspections, testing, monitoring, and repair of stay cable (including conventional methods) that you have found beneficial and are not listed above.

no answer

Additional comments?

Burlington, IA
Iowa

Questionnaire Results
Survey performed in 2004

Burlington, IA

State/Province: *Iowa*

Agency: *Iowa DOT*

Respondent: *Dean Bierwagen*

Span Length: *660 ft*

Year Built: *1995*

Q4-4: Type of main tension element (MTE)?

seven-wire steel strand—epoxy-coated, 0.6-in. strand, in grouted polyethylene pipe

Q4-5: Coating/treatment on main tension element within free length of cable?

epoxy-coated on outside only—epoxy-coated seven-wire strand

Q4-6: Are the coatings/treatments on main tension element discontinued or removed within the anchorage zone?

yes

Q4-7: Type of grout used?

not known—grout was used but not sure of content

Q4-8: Are filler materials used in the anchorage zone?

yes, other. Epoxy compound with zinc dust and steel ball

Q4-9: Type of anchorage?

“Hi-Am”-type—VSL Stay Cable System 250

Q4-10: Do cables go over “saddles” on the pylons?

no

Q4-11: Type of cable sheathing used?

HDPE with PVF Tedlar tape

Q4-12: Have rain–wind-induced cable vibrations been observed on this bridge?

yes

Q4-13: Have MTE corrosion problems been noted?

not known

Q4-14: Do cables have neoprene rings near the top and bottom anchorages?

yes

Q4-15: If there are neoprene rings on the cables; have there been any reports of movements of the rings out of their positions?

no, not known

Q4-16: Has moisture been found in any of the internal components of stay cables such as the bottom anchorage areas?

not known

Q4-17: Has fatigue of MTE or other components of stay cables been observed?

no

Q4-18: Do the cables have viscous dampers installed at deck or tower levels?

no

Q4-19: Do the cables have cross cables installed between them?

yes—retrofitted to correct vibrations

Q4-20: Do cables have other dampers (other than viscous or neoprene rings) to control vibrations?

yes, other—tie cables

Q4-21: Has cracking of the cable sheathing or sheathing connections been noted?

no

Q4-22: Has cracking or misalignment of the guide pipes been noted?

no

Q4-23: If there is protective tape wrapped around the cable sheathing; have there been reports of deterioration of the tape?

yes, minor damage

Q4-24: Have any problems associated with neoprene boots been noted?

no

Q4-25: Types of non-destructive tests that any of the cables on this bridge have been subjected to?

vibration-based force measurements—vibration measurements were done during construction to determine amount of force in cables.

Q4-26: Types of sensor-based, long-term monitoring performed on the cables?

NCHRP SYNTHESIS TOPIC 35-07—INSPECTION AND MAINTENANCE OF BRIDGE STAY CABLE SYSTEMS

Burlington, IA
Iowa

Questionnaire Results
Survey performed in 2004

not performed

Q4-27: Have the cables on this bridge (or any of their components) been repaired?

no

Q4-28: Has the sheathing been partially removed on any of the cables to examine condition of grout (if applicable) and/or the MTE?

no

Q4-29: Can the strands or cables be replaced if needed?

yes

Q4-30: Do you have an inspection and maintenance manual for this bridge?

yes

Q5: Based on your experience and in general, do you believe that the current inspection, testing, monitoring, and repair methods available to you for stay cables are effective and adequate?

no—need way to inspect cable

Q6: Please comment on the effectiveness of any non-destructive test methods for inspections of stay cables that you may be familiar with. These methods include (but are not limited to) ultrasonic testing, magnetic inspections, laser-based force measurements, X-ray imaging, etc. If possible, please comment on issues such as practicality, cost, duration, impact on traffic, and any other factors that you consider important.

Have not had experience with non-destructive test methods.

Q7: Please comment on the effectiveness of any cable vibration control measures that you may be familiar with. Examples include installation of cross cables, viscous dampers, neoprene rings, etc.

Have not had vibration problems since cross cables were installed.

Q8: Please comment on the effectiveness of any sensor-based, long-term monitoring systems for stay cables that you may be familiar with. Examples include acoustic monitoring, vibration monitoring, force measurements, strain measurements, etc.

Have not had experience with long-term monitoring.

Q9: What would you recommend that the cable suppliers incorporate into their systems to make cables more accessible and inspectable?

no answer

Q10: Do you believe that an up-to-date resource such as a national database of information on stay cable inspection methods, repairs, and testing would be a useful tool?

yes

Q11: What do you see as the single most important problem in stay cable maintenance?

The inability to inspect the elements inside the cable and the anchorage areas.

Q12: Please comment on any other methods for inspections, testing, monitoring, and repair of stay cable (including conventional methods) that you have found beneficial and are not listed above.

no answer

Additional comments?

NCHRP SYNTHESIS TOPIC 35-07—INSPECTION AND MAINTENANCE OF BRIDGE STAY CABLE SYSTEMS

William Natcher Bridge, Owensboro, KY
Kentucky

Questionnaire Results
Survey performed in 2004

**William Natcher Bridge,
Owensboro, KY**

State/Province: *Kentucky*

Agency: *Kentucky Transportation
Cabinet*

Respondent: *Darrell K. Dudgeon*

Span Length: *1,200 ft*

Year Built: *2002*

Q4-4: Type of main tension element (MTE)?
seven-wire steel strand

Q4-5: Coating/treatment on main tension
element within free length of cable?

greased-and-sheathed

Q4-6: Are the coatings/treatments on main
tension element discontinued or removed
within the anchorage zone?

*yes—tubes attached to the anchor block
provide corrosion protection.*

Q4-7: Type of grout used?

commercial prepackaged grouts

Q4-8: Are filler materials used in the
anchorage zone?

yes—grease

Q4-9: Type of anchorage?

wedges

Q4-10: Do cables go over “saddles” on the
pylons?

no

Q4-11: Type of cable sheathing used?

UV-resistant HDPE with spiral on surface

Q4-12: Have rain–wind-induced cable
vibrations been observed on this bridge?

no

Q4-13: Have MTE corrosion problems been
noted?

not known

Q4-14: Do cables have neoprene rings near the
top and bottom anchorages?

yes

Q4-15: If there are neoprene rings on the
cables; have there been any reports of
movements of the rings out of their positions?

no, not known

Q4-16: Has moisture been found in any of the
internal components of stay cables such as the
bottom anchorage areas?

*yes—moisture was detected during
construction when a cable slipped the wedge
and had to be replaced, but not since.*

Q4-17: Has fatigue of MTE or other
components of stay cables been observed?

no

Q4-18: Do the cables have viscous dampers
installed at deck or tower levels?

no

Q4-19: Do the cables have cross cables
installed between them?

yes—from the beginning

Q4-20: Do cables have other dampers (other
than viscous or neoprene rings) to control
vibrations?

no

Q4-21: Has cracking of the cable sheathing or
sheathing connections been noted?

no

Q4-22: Has cracking or misalignment of the
guide pipes been noted?

no

Q4-23: If there is protective tape wrapped
around the cable sheathing; have there been
reports of deterioration of the tape?

no

Q4-24: Have any problems associated with
neoprene boots been noted?

no

Q4-25: Types of non-destructive tests that any
of the cables on this bridge have been subjected
to?

not performed

NCHRP SYNTHESIS TOPIC 35-07—INSPECTION AND MAINTENANCE OF BRIDGE STAY CABLE SYSTEMS

**William Natcher Bridge, Owensboro, KY
Kentucky**

**Questionnaire Results
Survey performed in 2004**

Q4-26: Types of sensor-based, long-term monitoring performed on the cables?

not performed

Q4-27: Have the cables on this bridge (or any of their components) been repaired?

no

Q4-28: Has the sheathing been partially removed on any of the cables to examine condition of grout (if applicable) and/or the MTE?

no

Q4-29: Can the strands or cables be replaced if needed?

yes—cable only. Strand could not be replaced

Q4-30: Do you have an inspection and maintenance manual for this bridge?

yes

Q5: Based on your experience and in general, do you believe that the current inspection, testing, monitoring, and repair methods available to you for stay cables are effective and adequate?

no—there are technical limitations that prevent inspection of the stay cables, especially the anchorage area. Technical breakthrough is required.

Q6: Please comment on the effectiveness of any non-destructive test methods for inspections of stay cables that you may be familiar with. These methods include (but are not limited to) ultrasonic testing, magnetic

inspections, laser-based force measurements, X-ray imaging, etc. If possible, please comment on issues such as practicality, cost, duration, impact on traffic, and any other factors that you consider important.

The only problem is the anchorage area. So far no method is available for inspection. (PB) I see additional problems with inspection of the grout-filled cables. (DKD)

Q7: Please comment on the effectiveness of any cable vibration control measures that you may be familiar with. Examples include installation of cross cables, viscous dampers, neoprene rings, etc.

Wind damper is a high tech method that is very effective in most cases. However, the dampers are a delicate mechanism that need constant maintenance like any machine. Only the exterior dampers allow inspection and maintenance. Internal dampers are difficult to access for inspection. Any inspection and maintenance and/or replacement will be a major project. Another major concern is that the method to determine the damper's condition is still not available. Therefore, after only a few years, no one will know whether the installed dampers are still working. On the other hand, the cross cables will work as long as they are in place. The condition of the cross cables can be easily observed from the deck. Replacement of the cross ties is not a major operation. Therefore, before the damper is improved, the cross cable is the better and sure solution. (PB)

Q8: Please comment on the effectiveness of any sensor-based, long-term monitoring systems for stay cables that you may be familiar with. Examples include acoustic monitoring, vibration monitoring, force measurements, strain measurements, etc.

There are two problems on the monitoring systems. First, who will analyze the large amount of data collected. Second, how long will the sensors and the computer system last? We are talking about 100-year life span. The reality is that the monitoring system will fail or become obsolete within approximately 10 years when the bridge is not expected to have any problems. (PB)

Q9: What would you recommend that the cable suppliers incorporate into their systems to make cables more accessible and inspectable?

It seems not possible that the cable suppliers can do any more. (PB)

Q10: Do you believe that an up-to-date resource such as a national database of information on stay cable inspection methods, repairs, and testing would be a useful tool?

yes—resource does not exist so far. We (Parsons Brinkerhoff) are developing them right now. (PB)

Q11: What do you see as the single most important problem in stay cable maintenance?

*Inspecting the cable anchors. (PB)
Inspecting grout-filled cables. (DKD)*

Q12: Please comment on any other methods for inspections, testing, monitoring, and repair of

NCHRP SYNTHESIS TOPIC 35-07—INSPECTION AND MAINTENANCE OF BRIDGE STAY CABLE SYSTEMS

*William Natcher Bridge, Owensboro, KY
Kentucky*

*Questionnaire Results
Survey performed in 2004*

stay cable (including conventional methods)
that you have found beneficial and are not
listed above.

None

Additional comments?

Comments followed by (DKD) were made by Darrell Dudgeon of KYTC. Comments followed by (PB) were made by Ruchu Hsu, P.E. of Parsons Brinkerhoff Quade and Douglas, Inc. Consulting Engineers who was the lead design engineer for the Owensboro Bridge.

NCHRP SYNTHESIS TOPIC 35-07—INSPECTION AND MAINTENANCE OF BRIDGE STAY CABLE SYSTEMS

William H. Harsha Bridge, Maysville, KY
Kentucky

Questionnaire Results
Survey performed in 2004

**William H. Harsha Bridge,
Maysville, KY**

State/Province: *Kentucky*

Agency: *Kentucky Transportation
Cabinet*

Respondent: *Darrell K. Dudgeon*

Span Length: *1,050 ft*

Year Built: *2000*

Q4-4: Type of main tension element (MTE)?
seven-wire steel strand

Q4-5: Coating/treatment on main tension
element within free length of cable?

greased-and-sheathed

Q4-6: Are the coatings/treatments on main
tension element discontinued or removed
within the anchorage zone?

yes

Q4-7: Type of grout used?

cement-water admixtures

Q4-8: Are filler materials used in the
anchorage zone?

yes, grease

Q4-9: Type of anchorage?

conical socket with wedges

Q4-10: Do cables go over “saddles” on the
pylons?

no

Q4-11: Type of cable sheathing used?

UV-resistant HDPE with spiral on surface

Q4-12: Have rain-wind-induced cable
vibrations been observed on this bridge?

no

Q4-13: Have MTE corrosion problems been
noted?

no

Q4-14: Do cables have neoprene rings near the
top and bottom anchorages?

no

Q4-15: If there are neoprene rings on the
cables; have there been any reports of
movements of the rings out of their positions?

not applicable

Q4-16: Has moisture been found in any of the
internal components of stay cables such as the
bottom anchorage areas?

no

Q4-17: Has fatigue of MTE or other
components of stay cables been observed?

no

Q4-18: Do the cables have viscous dampers
installed at deck or tower levels?

no

Q4-19: Do the cables have cross cables
installed between them?

yes—from the beginning

Q4-20: Do cables have other dampers (other
than viscous or neoprene rings) to control
vibrations?

no

Q4-21: Has cracking of the cable sheathing or
sheathing connections been noted?

no answer

Q4-22: Has cracking or misalignment of the
guide pipes been noted?

no

Q4-23: If there is protective tape wrapped
around the cable sheathing; have there been
reports of deterioration of the tape?

not applicable

Q4-24: Have any problems associated with
neoprene boots been noted?

no

Q4-25: Types of non-destructive tests that any
of the cables on this bridge have been subjected
to?

not performed

Q4-26: Types of sensor-based, long-term
monitoring performed on the cables?

not performed

Q4-27: Have the cables on this bridge (or any
of their components) been repaired?

no

NCHRP SYNTHESIS TOPIC 35-07—INSPECTION AND MAINTENANCE OF BRIDGE STAY CABLE SYSTEMS

**William H. Harsha Bridge, Maysville, KY
Kentucky**

**Questionnaire Results
Survey performed in 2004**

Q4-28: Has the sheathing been partially removed on any of the cables to examine condition of grout (if applicable) and/or the MTE?

no

Q4-29: Can the strands or cables be replaced if needed?

yes

Q4-30: Do you have an inspection and maintenance manual for this bridge?

yes

Q5: Based on your experience and in general, do you believe that the current inspection, testing, monitoring, and repair methods available to you for stay cables are effective and adequate?

no—there are technical limitations that prevent inspection of the stay cables, especially the anchorage area. Technical breakthrough is required.

Q6: Please comment on the effectiveness of any non-destructive test methods for inspections of stay cables that you may be familiar with. These methods include (but are not limited to) ultrasonic testing, magnetic inspections, laser-based force measurements, X-ray imaging, etc. If possible, please comment on issues such as practicality, cost, duration, impact on traffic, and any other factors that you consider important.

The only problem is the anchorage area. So far no method is available for inspection. (PB)

I see additional problems with inspection of the grout-filled cables. (DKD)

Q7: Please comment on the effectiveness of any cable vibration control measures that you may be familiar with. Examples include installation of cross cables, viscous dampers, neoprene rings, etc.

Wind damper is a high tech method that is very effective in most cases. However, the dampers are delicate mechanisms that need constant maintenance like any machine. Only the exterior dampers allow inspection and maintenance. Internal dampers are difficult to access for inspection. Any inspection and maintenance and/or replacement will be a major project. Another major concern is that the method to determine the damper's condition is still not available. Therefore, after only a few years, no one will know whether the installed dampers are still working. On the other hand, the cross cables will work as long as they are in place. The condition of the cross cables can be easily observed from the deck. Replacement of the cross ties is not a major operation. Therefore, before the damper is improved, the cross cable is the better and sure solution. (PB)

Q8: Please comment on the effectiveness of any sensor-based, long-term monitoring systems for stay cables that you may be familiar with. Examples include acoustic monitoring, vibration monitoring, force measurements, strain measurements, etc.

There are two problems on the monitoring systems. First, who will analyze the large

amount of data collected. Second, how long will the sensors and the computer system last? We are talking about 100-year life span. The reality is that the monitoring system will fail or become obsolete within approximately 10 years when the bridge is not expected to have any problems. (PB)

Q9: What would you recommend that the cable suppliers incorporate into their systems to make cables more accessible and inspectable?

It seems not possible that the cable suppliers can do any more. (PB)

Q10: Do you believe that an up-to-date resource such as a national database of information on stay cable inspection methods, repairs, and testing would be a useful tool?

yes—resource does not exist so far. We (Parsons Brinkerhoff) are developing them right now. (PB)

Q11: What do you see as the single most important problem in stay cable maintenance?

*Inspecting the cable anchors. (PB)
Inspecting grout-filled cables. (DKD)*

Q12: Please comment on any other methods for inspections, testing, monitoring, and repair of stay cable (including conventional methods) that you have found beneficial and are not listed above.

none

Additional comments?

Comments followed by (DKD) were made by Darrell Dudgeon of KYTC. Comments

NCHRP SYNTHESIS TOPIC 35-07—INSPECTION AND MAINTENANCE OF BRIDGE STAY CABLE SYSTEMS

*William H. Harsha Bridge, Maysville, KY
Kentucky*

*Questionnaire Results
Survey performed in 2004*

followed by (PB) were made by Ruchu Hsu, P.E. of Parsons Brinkerhoff Quade and Douglas, Inc. Consulting Engineers who was the lead design engineer for the Owensboro Bridge.

NCHRP SYNTHESIS TOPIC 35-07—INSPECTION AND MAINTENANCE OF BRIDGE STAY CABLE SYSTEMS

Mississippi River Bridge at Luling, LA
Louisiana

Questionnaire Results
Survey performed in 2004

**Mississippi River Bridge at
Luling, LA**

State/Province: *Louisiana*

Agency: *Louisiana DOTD*

Respondent: *Gill Gautreau*

Span Length: *1,222 ft*

Year Built: *1984*

Q4-4: Type of main tension element (MTE)?
steel wire

Q4-5: Coating/treatment on main tension element within free length of cable?

bare

Q4-6: Are the coatings/treatments on main tension element discontinued or removed within the anchorage zone?

not applicable

Q4-7: Type of grout used?

cement–water

Q4-8: Are filler materials used in the anchorage zone?

yes, other

Q4-9: Type of anchorage?

“Hi-Am”- type—Each wire also passes through a plate and has a button head anchor

Q4-10: Do cables go over “saddles” on the pylons?

no

Q4-11: Type of cable sheathing used?

HDPE with PVF (Tedlar) tape

Q4-12: Have rain–wind-induced cable vibrations been observed on this bridge?

no—very infrequent, large amplitude motion observed, but not detected.*

Q4-13: Have MTE corrosion problems been noted?

yes—see CTL report of July 2004

Q4-14: Do cables have neoprene rings near the top and bottom anchorages?

yes

Q4-15: If there are neoprene rings on the cables; have there been any reports of movements of the rings out of their positions?

yes—due to other reasons

Q4-16: Has moisture been found in any of the internal components of stay cables such as the bottom anchorage areas?

yes—see July 2004 CTL report

Q4-17: Has fatigue of MTE or other components of stay cables been observed?

no

Q4-18: Do the cables have viscous dampers installed at deck or tower levels?

no

Q4-19: Do the cables have cross cables installed between them?

no

Q4-20: Do cables have other dampers (other than viscous or neoprene rings) to control vibrations?

no

Q4-21: Has cracking of the cable sheathing or sheathing connections been noted?

yes, sheathing

Q4-22: Has cracking or misalignment of the guide pipes been noted?

no

Q4-23: If there is protective tape wrapped around the cable sheathing; have there been reports of deterioration of the tape?

yes—moderate damage—damaged areas of undetermined cause. Look to be impact, but very high off deck.

Q4-24: Have any problems associated with neoprene boots been noted?

yes—not boots, washers—split neoprene washers are held in place by bolts and caulked.

Q4-25: Types of non-destructive tests that any of the cables on this bridge have been subjected to?

vibration-based force measurements

NCHRP SYNTHESIS TOPIC 35-07—INSPECTION AND MAINTENANCE OF BRIDGE STAY CABLE SYSTEMS

*Mississippi River Bridge at Luling, LA
Louisiana*

*Questionnaire Results
Survey performed in 2004*

Q4-26: Types of sensor-based, long-term monitoring performed on the cables?

vibration monitoring

Q4-27: Have the cables on this bridge (or any of their components) been repaired?

yes—splits in early years repaired by heat welding, wrapped with Tedlar tape.

Q4-28: Has the sheathing been partially removed on any of the cables to examine condition of grout (if applicable) and/or the MTE?

no—planned for next inspection contract phase with CTL

Q4-29: Can the strands or cables be replaced if needed?

yes, not easily

Q4-30: Do you have an inspection and maintenance manual for this bridge?

no

Q5: Based on your experience and in general, do you believe that the current inspection, testing, monitoring, and repair methods available to you for stay cables are effective and adequate?

not known—our vibration tests over time have indicated consistent cable loads; we are still unable to call the wires pristine.

Q6: Please comment on the effectiveness of any non-destructive test methods for inspections of stay cables that you may be familiar with. These methods include (but are

not limited to) ultrasonic testing, magnetic inspections, laser-based force measurements, X-ray imaging, etc. If possible, please comment on issues such as practicality, cost, duration, impact on traffic, and any other factors that you consider important.

Vibration-based cable load determination—effective and inexpensive; X-ray—expensive, slow, very questionable ability to detect wire defects; Magnetic inspection—used to rapidly, effectively inspect mine cables, but the cables move past the inspection unit, which would need to be reversed on a cable bridge; Impulse radar—good for detecting grout defects; Sonic methods—dampened to the point of being ineffective.

Q7: Please comment on the effectiveness of any cable vibration control measures that you may be familiar with. Examples include installation of cross cables, viscous dampers, neoprene rings, etc.

Luling has neoprene rings, but these are relatively very small considering the large diameter of the Luling cables and are there mainly to seal the anchors, but perhaps they also dampen the cables. CTL will check into this.

Q8: Please comment on the effectiveness of any sensor-based, long-term monitoring systems for stay cables that you may be familiar with. Examples include acoustic monitoring, vibration monitoring, force measurements, strain measurements, etc.

Vibration monitoring has been ongoing at Luling for 20 years in anticipation of a hurricane striking the bridge—no significant long duration winds have occurred.

Q9: What would you recommend that the cable suppliers incorporate into their systems to make cables more accessible and inspectable?

I like the idea of hermetically sealed, ungrouted cables with fiber optic sensors throughout or exposed wire that can be directly inspected.

Q10: Do you believe that an up-to-date resource such as a national database of information on stay cable inspection methods, repairs, and testing would be a useful tool?

yes

Q11: What do you see as the single most important problem in stay cable maintenance?

The hidden nature of the system.

Q12: Please comment on any other methods for inspections, testing, monitoring, and repair of stay cable (including conventional methods) that you have found beneficial and are not listed above.

no answer

Additional comments?

no answer

NCHRP SYNTHESIS TOPIC 35-07—INSPECTION AND MAINTENANCE OF BRIDGE STAY CABLE SYSTEMS

Questionnaire Results
Survey performed in 2004

Arkansas (Mississippi)

State/Province: *Arkansas (Mississippi)*

Agency: *Arkansas/Mississippi DOT*

Respondent: *Phil Brand/Mitchell Carr*

Span Length: *ft*

Year Built:

Q4-4: Type of main tension element (MTE)?

Q4-5: Coating/treatment on main tension element within free length of cable?

Q4-6: Are the coatings/treatments on main tension element discontinued or removed within the anchorage zone?

Q4-7: Type of grout used?

Q4-8: Are filler materials used in the anchorage zone?

Q4-9: Type of anchorage?

Q4-10: Do cables go over “saddles” on the pylons?

Q4-11: Type of cable sheathing used?

Q4-12: Have rain–wind-induced cable vibrations been observed on this bridge?

Q4-13: Have MTE corrosion problems been noted?

Q4-14: Do cables have neoprene rings near the top and bottom anchorages?

Q4-15: If there are neoprene rings on the cables; have there been any reports of movements of the rings out of their positions?

Q4-16: Has moisture been found in any of the internal components of stay cables such as the bottom anchorage areas?

Q4-17: Has fatigue of MTE or other components of stay cables been observed?

Q4-18: Do the cables have viscous dampers installed at deck or tower levels?

Q4-19: Do the cables have cross cables installed between them?

Q4-20: Do cables have other dampers (other than viscous or neoprene rings) to control vibrations?

Q4-21: Has cracking of the cable sheathing or sheathing connections been noted?

Q4-22: Has cracking or misalignment of the guide pipes been noted?

Q4-23: If there is protective tape wrapped around the cable sheathing; have there been reports of deterioration of the tape?

Q4-24: Have any problems associated with neoprene boots been noted?

Q4-25: Types of non-destructive tests that any of the cables on this bridge have been subjected to?

Q4-26: Types of sensor-based, long-term monitoring performed on the cables?

Q4-27: Have the cables on this bridge (or any of their components) been repaired?

Q4-28: Has the sheathing been partially removed on any of the cables to examine

condition of grout (if applicable) and/or the MTE?

Q4-29: Can the strands or cables be replaced if needed?

Q4-30: Do you have an inspection and maintenance manual for this bridge?

Q5: Based on your experience and in general, do you believe that the current inspection, testing, monitoring, and repair methods available to you for stay cables are effective and adequate?

Not known—we are several years away from completion of the first cable-stayed bridge for which Arkansas will have responsibility for inspection/maintenance/not known

Q6: Please comment on the effectiveness of any non-destructive test methods for inspections of stay cables that you may be familiar with. These methods include (but are not limited to) ultrasonic testing, magnetic inspections, laser-based force measurements, X-ray imaging, etc. If possible, please comment on issues such as practicality, cost, duration, impact on traffic, and any other factors that you consider important.

No comment/not known

Q7: Please comment on the effectiveness of any cable vibration control measures that you may be familiar with. Examples include installation of cross cables, viscous dampers, neoprene rings, etc.

No comment/we are currently constructing a cable-stayed bridge on US-82 over the

NCHRP SYNTHESIS TOPIC 35-07—INSPECTION AND MAINTENANCE OF BRIDGE STAY CABLE SYSTEMS

Questionnaire Results
Survey performed in 2004

Arkansas (Mississippi)

Mississippi River near Greenville, MS. Mississippi is responsible for overseeing the construction and Arkansas will be responsible for the maintenance. We are sharing the costs associated with both construction and maintenance. We are using cable ties and cable stay sheathing with a helical drip bead to control the cable vibration. We considered using dampners and a combination of dampners and cable ties. However, we were not comfortable with the reliability of dampners and felt the cable ties have a long-standing proven record. A visual inspection would show problems with the ties, whereas with the dampners it is not so easy to determine if they are working properly.

Q8: Please comment on the effectiveness of any sensor-based, long-term monitoring systems for stay cables that you may be familiar with. Examples include acoustic monitoring, vibration monitoring, force measurements, strain measurements, etc.

No comment/not known

Q9: What would you recommend that the cable suppliers incorporate into their systems to make cables more accessible and inspectable?

No comment/no comment

Q10: Do you believe that an up-to-date resource such as a national database of information on stay cable inspection methods, repairs, and testing would be a useful tool?

Not known/yes

Q11: What do you see as the single most important problem in stay cable maintenance?

No comment/we do not have enough experience in this area to comment.

Q12: Please comment on any other methods for inspections, testing, monitoring, and repair of stay cable (including conventional methods) that you have found beneficial and are not listed above.

N/A–N/A

Additional comments?

NCHRP SYNTHESIS TOPIC 35-07—INSPECTION AND MAINTENANCE OF BRIDGE STAY CABLE SYSTEMS

Leonard P. Zakim Bunker Hill Bridge, Boston, MA
Massachusetts

Questionnaire Results
Survey performed in 2004

**Leonard P. Zakim Bunker Hill
Bridge, Boston, MA**

State/Province: *Massachusetts*

Agency: *Massachusetts Turnpike
Authority*

Respondent: *Anthony Ricci*

Span Length: *745 ft*

Year Built: *2002*

Q4-4: Type of main tension element (MTE)?

seven-wire steel strand

Q4-5: Coating/treatment on main tension element within free length of cable?

greased-and-sheathed

Q4-6: Are the coatings/treatments on main tension element discontinued or removed within the anchorage zone?

yes—sheathing removed in the anchorage zone

Q4-7: Type of grout used?

grout not used

Q4-8: Are filler materials used in the anchorage zone?

yes, other—wax

Q4-9: Type of anchorage?

wedges

Q4-10: Do cables go over “saddles” on the pylons?

no

Q4-11: Type of cable sheathing used?

UV-resistant HDPE with spiral on surface

Q4-12: Have rain–wind-induced cable vibrations been observed on this bridge?

no

Q4-13: Have MTE corrosion problems been noted?

no

Q4-14: Do cables have neoprene rings near the top and bottom anchorages?

no—internal dampers at deck level, stuffing box with HDPE drilled plate and compressive material at pylon

Q4-15: If there are neoprene rings on the cables; have there been any reports of movements of the rings out of their positions?

not applicable

Q4-16: Has moisture been found in any of the internal components of stay cables such as the bottom anchorage areas?

no

Q4-17: Has fatigue of MTE or other components of stay cables been observed?

no

Q4-18: Do the cables have viscous dampers installed at deck or tower levels?

yes, from the beginning—internal dampers at deck level

Q4-19: Do the cables have cross cables installed between them?

yes—from the beginning

Q4-20: Do cables have other dampers (other than viscous or neoprene rings) to control vibrations?

no

Q4-21: Has cracking of the cable sheathing or sheathing connections been noted?

no

Q4-22: Has cracking or misalignment of the guide pipes been noted?

no

Q4-23: If there is protective tape wrapped around the cable sheathing; have there been reports of deterioration of the tape?

not applicable

Q4-24: Have any problems associated with neoprene boots been noted?

no—not applicable

Q4-25: Types of non-destructive tests that any of the cables on this bridge have been subjected to?

not performed

NCHRP SYNTHESIS TOPIC 35-07—INSPECTION AND MAINTENANCE OF BRIDGE STAY CABLE SYSTEMS

**Leonard P. Zakim Bunker Hill Bridge, Boston, MA
Massachusetts**

**Questionnaire Results
Survey performed in 2004**

Q4-26: Types of sensor-based, long-term monitoring performed on the cables?

not performed

Q4-27: Have the cables on this bridge (or any of their components) been repaired?

no

Q4-28: Has the sheathing been partially removed on any of the cables to examine condition of grout (if applicable) and/or the MTE?

no

Q4-29: Can the strands or cables be replaced if needed?

yes

Q4-30: Do you have an inspection and maintenance manual for this bridge?

yes

Q5: Based on your experience and in general, do you believe that the current inspection, testing, monitoring, and repair methods available to you for stay cables are effective and adequate?

yes

Q6: Please comment on the effectiveness of any non-destructive test methods for inspections of stay cables that you may be familiar with. These methods include (but are not limited to) ultrasonic testing, magnetic inspections, laser-based force measurements, X-ray imaging, etc. If possible, please comment on issues such as practicality, cost,

duration, impact on traffic, and any other factors that you consider important.

Have not yet used any NDT methods for stay cable inspection.

Q7: Please comment on the effectiveness of any cable vibration control measures that you may be familiar with. Examples include installation of cross cables, viscous dampers, neoprene rings, etc.

It is our opinion that neoprene rings will not work as intended. Either internal or external viscous dampers are needed. Cross cables are not needed in shorter spans.

Q8: Please comment on the effectiveness of any sensor-based, long-term monitoring systems for stay cables that you may be familiar with. Examples include acoustic monitoring, vibration monitoring, force measurements, strain measurements, etc.

none

Q9: What would you recommend that the cable suppliers incorporate into their systems to make cables more accessible and inspectable?

transparent outer pipe, eliminate grout

Q10: Do you believe that an up-to-date resource such as a national database of information on stay cable inspection methods, repairs, and testing would be a useful tool?

yes

Q11: What do you see as the single most important problem in stay cable maintenance?

Access for inspection

Q12: Please comment on any other methods for inspections, testing, monitoring, and repair of stay cable (including conventional methods) that you have found beneficial and are not listed above.

Stay cable anchorage design should allow for accessibility for inspection. Inspection, maintenance, and replacement should be addressed during design.

Additional comments?

no answer

NCHRP SYNTHESIS TOPIC 35-07—INSPECTION AND MAINTENANCE OF BRIDGE STAY CABLE SYSTEMS

Bill Emerson Memorial Bridge, Cape Girardeau
Missouri

Questionnaire Results
Survey performed in 2004

**Bill Emerson Memorial Bridge,
Cape Girardeau**

State/Province: *Missouri*

Agency: *MoDOT*

Respondent: *Greg Sunde*

Span Length: *1,150 ft*

Year Built: *2003*

Q4-4: Type of main tension element (MTE)?

seven-wire steel strand

Q4-5: Coating/treatment on main tension element within free length of cable?

greased-and-sheathed

Q4-6: Are the coatings/treatments on main tension element discontinued or removed within the anchorage zone?

yes

Q4-7: Type of grout used?

cement–water admixtures

Q4-8: Are filler materials used in the anchorage zone?

yes, grease

Q4-9: Type of anchorage?

wedges

Q4-10: Do cables go over “saddles” on the pylons?

no

Q4-11: Type of cable sheathing used?

UV-resistant HDPE with spiral on surface

Q4-12: Have rain–wind-induced cable vibrations been observed on this bridge?

no

Q4-13: Have MTE corrosion problems been noted?

no

Q4-14: Do cables have neoprene rings near the top and bottom anchorages?

yes

Q4-15: If there are neoprene rings on the cables; have there been any reports of movements of the rings out of their positions?

no, not known

Q4-16: Has moisture been found in any of the internal components of stay cables such as the bottom anchorage areas?

no

Q4-17: Has fatigue of MTE or other components of stay cables been observed?

no

Q4-18: Do the cables have viscous dampers installed at deck or tower levels?

no

Q4-19: Do the cables have cross cables installed between them?

yes, from the beginning

Q4-20: Do cables have other dampers (other than viscous or neoprene rings) to control vibrations?

no

Q4-21: Has cracking of the cable sheathing or sheathing connections been noted?

no

Q4-22: Has cracking or misalignment of the guide pipes been noted?

no

Q4-23: If there is protective tape wrapped around the cable sheathing; have there been reports of deterioration of the tape?

no

Q4-24: Have any problems associated with neoprene boots been noted?

no

Q4-25: Types of non-destructive tests that any of the cables on this bridge have been subjected to?

not performed

Q4-26: Types of sensor-based, long-term monitoring performed on the cables?

not performed

Q4-27: Have the cables on this bridge (or any of their components) been repaired?

yes—splices were added to HDPE sheathing during construction of a couple of cables

NCHRP SYNTHESIS TOPIC 35-07—INSPECTION AND MAINTENANCE OF BRIDGE STAY CABLE SYSTEMS

**Bill Emerson Memorial Bridge, Cape Girardeau
Missouri**

**Questionnaire Results
Survey performed in 2004**

Q4-28: Has the sheathing been partially removed on any of the cables to examine condition of grout (if applicable) and/or the MTE?

no

Q4-29: Can the strands or cables be replaced if needed?

yes

Q4-30: Do you have an inspection and maintenance manual for this bridge?

no

Q5: Based on your experience and in general, do you believe that the current inspection, testing, monitoring, and repair methods available to you for stay cables are effective and adequate?

not known—MoDOT has no related experience

Q6: Please comment on the effectiveness of any non-destructive test methods for inspections of stay cables that you may be familiar with. These methods include (but are not limited to) ultrasonic testing, magnetic inspections, laser-based force measurements, X-ray imaging, etc. If possible, please comment on issues such as practicality, cost, duration, impact on traffic, and any other factors that you consider important.

MoDOT has no related experience

Q7: Please comment on the effectiveness of any cable vibration control measures that you may be familiar with. Examples include

installation of cross cables, viscous dampers, neoprene rings, etc.

Cross cables have been installed on this bridge as the most effective, positive method to eliminate cable vibrations. We understand that worldwide research is being conducted to maximize the efficiency of dampers and to determine, mathematically when they are and are not required

Q8: Please comment on the effectiveness of any sensor-based, long-term monitoring systems for stay cables that you may be familiar with. Examples include acoustic monitoring, vibration monitoring, force measurements, strain measurements, etc.

MoDOT has no related experience

Q9: What would you recommend that the cable suppliers incorporate into their systems to make cables more accessible and inspectable?

Perhaps a permanent load cell that would permit real-time readings of cable forces at any time during the life of the bridge

Q10: Do you believe that an up-to-date resource such as a national database of information on stay cable inspection methods, repairs, and testing would be a useful tool?

yes

Q11: What do you see as the single most important problem in stay cable maintenance?

The integrity of the stays. Grouted cables are impossible to inspect with a non-destructive technique (i.e., one that does not require

removal of sheathing and grout); thus, it is impossible to identify corrosion problems early.

Q12: Please comment on any other methods for inspections, testing, monitoring, and repair of stay cable (including conventional methods) that you have found beneficial and are not listed above.

MoDOT has no related experience

Additional comments?

*Maumee River Bridge
Ohio*

*Questionnaire Results
Survey performed in 2004*

**Maumee River Bridge, Toledo,
Ohio**

State/Province: *Ohio*

Agency: *Figg Bridge Engineers*

Respondent: *W. Denny Pate*

Span Length: *2 stayed spans of 612.5'
(single tower) ft*

Year Built: *Currently under
construction (2004)*

Q4-4: Type of main tension element (MTE)?
seven-wire steel strand

Q4-5: Coating/treatment on main tension
element within free length of cable?

epoxy-coated inside and outside

Q4-6: Are the coatings/treatments on main
tension element discontinued or removed
within the anchorage zone?

yes

Q4-7: Type of grout used?

grout not used

Q4-8: Are filler materials used in the
anchorage zone?

yes, grease

Q4-9: Type of anchorage?

wedges

Q4-10: Do cables go over “saddles” on the
pylons?

*yes—This project actually uses a “cradle”
that separates individual strands within the
curved area, avoiding contact stress between
them. In that respect, it is different than
conventional “saddles.”*

Q4-11: Type of cable sheathing used?

other, stainless steel

Q4-12: Have rain–wind-induced cable
vibrations been observed on this bridge?

no

Q4-13: Have MTE corrosion problems been
noted?

no

Q4-14: Do cables have neoprene rings near the
top and bottom anchorages?

no

Q4-15: If there are neoprene rings on the
cables; have there been any reports of
movements of the rings out of their positions?

not applicable

Q4-16: Has moisture been found in any of the
internal components of stay cables such as the
bottom anchorage areas?

no

Q4-17: Has fatigue of MTE or other
components of stay cables been observed?

no

Q4-18: Do the cables have viscous dampers
installed at deck or tower levels?

yes—from the beginning

Q4-19: Do the cables have cross cables
installed between them?

no

Q4-20: Do cables have other dampers (other
than viscous or neoprene rings) to control
vibrations?

no

Q4-21: Has cracking of the cable sheathing or
sheathing connections been noted?

no

Q4-22: Has cracking or misalignment of the
guide pipes been noted?

no

Q4-23: If there is protective tape wrapped
around the cable sheathing; have there been
reports of deterioration of the tape?

not applicable

Q4-24: Have any problems associated with
neoprene boots been noted?

no

Q4-25: Types of non-destructive tests that any
of the cables on this bridge have been subjected
to?

not performed

Q4-26: Types of sensor-based, long-term
monitoring performed on the cables?

not performed

NCHRP SYNTHESIS TOPIC 35-07—INSPECTION AND MAINTENANCE OF BRIDGE STAY CABLE SYSTEMS

**Maumee River Bridge
Ohio**

**Questionnaire Results
Survey performed in 2004**

Q4-27: Have the cables on this bridge (or any of their components) been repaired?

no

Q4-28: Has the sheathing been partially removed on any of the cables to examine condition of grout (if applicable) and/or the MTE?

no

Q4-29: Can the strands or cables be replaced if needed?

yes

Q4-30: Do you have an inspection and maintenance manual for this bridge?

no answer

Q5: Based on your experience and in general, do you believe that the current inspection, testing, monitoring, and repair methods available to you for stay cables are effective and adequate?

yes—while better methods may be developed in the future, the current methods are both effective and adequate. The most likely location of cable issues on all such bridges is at the anchor areas. By the nature of the anchor being embedded in massive concrete or steel areas, direct access to inspect the MTE is generally impractical.

Q6: Please comment on the effectiveness of any non-destructive test methods for inspections of stay cables that you may be familiar with. These methods include (but are not limited to) ultrasonic testing, magnetic

inspections, laser-based force measurements, X-ray imaging, etc. If possible, please comment on issues such as practicality, cost, duration, impact on traffic, and any other factors that you consider important.

no answer

Q7: Please comment on the effectiveness of any cable vibration control measures that you may be familiar with. Examples include installation of cross cables, viscous dampers, neoprene rings, etc.

Volumes can be written on this topic. The short version is that any actual “damping” added to the cable is highly effective since by its nature the cable has very little. Other control measures have had various degrees of success. In most cases, the success or lack of success has been related to the actual details, not so much in the selected approach to the issue.

Q8: Please comment on the effectiveness of any sensor-based, long-term monitoring systems for stay cables that you may be familiar with. Examples include acoustic monitoring, vibration monitoring, force measurements, strain measurements, etc.

no answer

Q9: What would you recommend that the cable suppliers incorporate into their systems to make cables more accessible and inspectable?

Access is a very sharp two-edged sword. If you can more easily access the cable, so can corrosive elements (not to mention potential terrorist/security considerations).

Q10: Do you believe that an up-to-date resource such as a national database of information on stay cable inspection methods, repairs, and testing would be a useful tool?

not known—while information can be useful, it can also be misinterpreted. The best resource is direct contact with those who have hands-on knowledge related to the specific area that an individual may be making inquiries.

Q11: What do you see as the single most important problem in stay cable maintenance?

The largest “problem” with stay cables is that they are widely perceived as “a problem” rather than just another bridge member with specific needs and characteristics. Stay cables have been placed unnecessarily “on a pedestal.” While they are a very important bridge member, in current designs they are highly redundant, overtested, and (relatively) easily replaced. There is no other major bridge member that fits into all three of these categories. Let’s not promote the feeling that stays are “a maintenance problem.”

Q12: Please comment on any other methods for inspections, testing, monitoring, and repair of stay cable (including conventional methods) that you have found beneficial and are not listed above.

no answer

Additional comments?

no answer

Cooper River Bridge
South Carolina

Questionnaire Results
Survey performed in 2004

Cooper River Bridge

State/Province: *South Carolina*

Agency: *South Carolina DOT*

Respondent: *Charles T. Dwyer*

Span Length: *1546 ft*

Year Built: *2005*

Q4-4: Type of main tension element (MTE)?

seven-wire steel strand

Q4-5: Coating/treatment on main tension element within free length of cable?

other—waxed and sheathed

Q4-6: Are the coatings/treatments on main tension element discontinued or removed within the anchorage zone?

yes

Q4-7: Type of grout used?

grout not used

Q4-8: Are filler materials used in the anchorage zone?

yes, other

Q4-9: Type of anchorage?

wedges

Q4-10: Do cables go over “saddles” on the pylons?

no

Q4-11: Type of cable sheathing used?

UV-resistant HDPE with spiral on surface

Q4-12: Have rain–wind-induced cable vibrations been observed on this bridge?

N/A

Q4-13: Have MTE corrosion problems been noted?

N/A

Q4-14: Do cables have neoprene rings near the top and bottom anchorages?

N/A

Q4-15: If there are neoprene rings on the cables; have there been any reports of movements of the rings out of their positions?

N/A

Q4-16: Has moisture been found in any of the internal components of stay cables such as the bottom anchorage areas?

N/A

Q4-17: Has fatigue of MTE or other components of stay cables been observed?

N/A

Q4-18: Do the cables have viscous dampers installed at deck or tower levels?

yes—from the beginning

Q4-19: Do the cables have cross cables installed between them?

no—bridge not finished. A provisional feature if needed.

Q4-20: Do cables have other dampers (other than viscous or neoprene rings) to control vibrations?

yes—external hydraulic dampers

Q4-21: Has cracking of the cable sheathing or sheathing connections been noted?

N/A

Q4-22: Has cracking or misalignment of the guide pipes been noted?

not known

Q4-23: If there is protective tape wrapped around the cable sheathing; have there been reports of deterioration of the tape?

N/A

Q4-24: Have any problems associated with neoprene boots been noted?

not known

Q4-25: Types of non-destructive tests that any of the cables on this bridge have been subjected to?

not performed

Q4-26: Types of sensor-based, long-term monitoring performed on the cables?

not performed

Q4-27: Have the cables on this bridge (or any of their components) been repaired?

NCHRP SYNTHESIS TOPIC 35-07—INSPECTION AND MAINTENANCE OF BRIDGE STAY CABLE SYSTEMS

Cooper River Bridge
South Carolina

Questionnaire Results
Survey performed in 2004

no

Q4-28: Has the sheathing been partially removed on any of the cables to examine condition of grout (if applicable) and/or the MTE?

not known

Q4-29: Can the strands or cables be replaced if needed?

yes

Q4-30: Do you have an inspection and maintenance manual for this bridge?

yes—required submittal upon completion in 2005

Q5: Based on your experience and in general, do you believe that the current inspection, testing, monitoring, and repair methods available to you for stay cables are effective and adequate?

yes

Q6: Please comment on the effectiveness of any non-destructive test methods for inspections of stay cables that you may be familiar with. These methods include (but are not limited to) ultrasonic testing, magnetic inspections, laser-based force measurements, X-ray imaging, etc. If possible, please comment on issues such as practicality, cost, duration, impact on traffic, and any other factors that you consider important.

no comment

Q7: Please comment on the effectiveness of any cable vibration control measures that you may be familiar with. Examples include installation of cross cables, viscous dampers, neoprene rings, etc.

Viscous dampers for all cables and additional external dampers for the longest cables are in plans and will be installed. Cross cable dampers are a future consideration. Provisions for future installation of cross cables will be installed. If the system of viscous and external dampers is inadequate, the cross cables can be installed.

Q8: Please comment on the effectiveness of any sensor-based, long-term monitoring systems for stay cables that you may be familiar with. Examples include acoustic monitoring, vibration monitoring, force measurements, strain measurements, etc.

none

Q9: What would you recommend that the cable suppliers incorporate into their systems to make cables more accessible and inspectable?

Include a maintenance manual with clear instructions for both specific wires or full cables.

Q10: Do you believe that an up-to-date resource such as a national database of information on stay cable inspection methods, repairs, and testing would be a useful tool?

yes

Q11: What do you see as the single most important problem in stay cable maintenance?

Provide end caps that are easily removed and fully protected against corrosion.

Q12: Please comment on any other methods for inspections, testing, monitoring, and repair of stay cable (including conventional methods) that you have found beneficial and are not listed above.

no answer

Additional comments?

NCHRP SYNTHESIS TOPIC 35-07—INSPECTION AND MAINTENANCE OF BRIDGE STAY CABLE SYSTEMS

Veterans Memorial Bridge
Texas

Questionnaire Results
Survey performed in 2004

Veterans Memorial Bridge

State/Province: *Texas*

Agency: *Texas DOT*

Respondent: *Keith Ramsey*

Span Length: *640 ft*

Year Built: *1991*

Q4-4: Type of main tension element (MTE)?

seven-wire steel strand

Q4-5: Coating/treatment on main tension element within free length of cable?

bare

Q4-6: Are the coatings/treatments on main tension element discontinued or removed within the anchorage zone?

N/A—grouted though entire length and anchorage

Q4-7: Type of grout used?

cement–water admixtures

Q4-8: Are filler materials used in the anchorage zone?

yes, other—grout

Q4-9: Type of anchorage?

conical socket with wedges

Q4-10: Do cables go over “saddles” on the pylons?

yes

Q4-11: Type of cable sheathing used?

HDPE with PVF Tedlar tape

Q4-12: Have rain–wind-induced cable vibrations been observed on this bridge?

yes

Q4-13: Have MTE corrosion problems been noted?

no

Q4-14: Do cables have neoprene rings near the top and bottom anchorages?

yes

Q4-15: If there are neoprene rings on the cables; have there been any reports of movements of the rings out of their positions?

yes—due to loosening of retainers

Q4-16: Has moisture been found in any of the internal components of stay cables such as the bottom anchorage areas?

no

Q4-17: Has fatigue of MTE or other components of stay cables been observed?

no

Q4-18: Do the cables have viscous dampers installed at deck or tower levels?

yes—retrofitted to correct vibrations; presently being installed

Q4-19: Do the cables have cross cables installed between them?

no

Q4-20: Do cables have other dampers (other than viscous or neoprene rings) to control vibrations?

no

Q4-21: Has cracking of the cable sheathing or sheathing connections been noted?

no

Q4-22: Has cracking or misalignment of the guide pipes been noted?

no

Q4-23: If there is protective tape wrapped around the cable sheathing; have there been reports of deterioration of the tape?

yes, minor damage

Q4-24: Have any problems associated with neoprene boots been noted?

no

Q4-25: Types of non-destructive tests that any of the cables on this bridge have been subjected to?

Vibration-based force measurements, used to aid in the design of viscous dampers for the bridge. Performed periodically to compare predampened response to post-dampened response.

Q4-26: Types of sensor-based, long-term monitoring performed on the cables?

NCHRP SYNTHESIS TOPIC 35-07—INSPECTION AND MAINTENANCE OF BRIDGE STAY CABLE SYSTEMS

Veterans Memorial Bridge
Texas

Questionnaire Results
Survey performed in 2004

acoustic wire break detection, vibration monitoring, other—Have long-term weather monitoring to associate with oscillation events.

Q4-27: Have the cables on this bridge (or any of their components) been repaired?

yes—retightened the retainers for the neoprene rings

Q4-28: Has the sheathing been partially removed on any of the cables to examine condition of grout (if applicable) and/or the MTE?

no

Q4-29: Can the strands or cables be replaced if needed?

yes

Q4-30: Do you have an inspection and maintenance manual for this bridge?

yes

Q5: Based on your experience and in general, do you believe that the current inspection, testing, monitoring, and repair methods available to you for stay cables are effective and adequate?

yes—owners are unable to non-destructively evaluate the condition of stay cables and anchorages.

Q6: Please comment on the effectiveness of any non-destructive test methods for inspections of stay cables that you may be familiar with. These methods include (but are

not limited to) ultrasonic testing, magnetic inspections, laser-based force measurements, X-ray imaging, etc. If possible, please comment on issues such as practicality, cost, duration, impact on traffic, and any other factors that you consider important.

TxDOT has employed vibration-based force measurements to refine the model used for designing viscous dampers on each of the cable stay bridges. The technique seemed to give good correlation cable dimensions and damping requirements. The technique requires some traffic control and depending on the number of lanes carried by the structure could produce minor to significant traffic disruption. At least one lane and the shoulder will need to be closed, therefore if the bridge is narrow with a small number of lanes carrying two-way traffic the disruption could be considerable. This could last for several weeks if there are a large number of stays that need to be tested. The cost can run anywhere from \$50,000 to \$75,000 per bridge per test event depending on the size of the structure.

Q7: Please comment on the effectiveness of any cable vibration control measures that you may be familiar with. Examples include installation of cross cables, viscous dampers, neoprene rings, etc.

The only cable vibration control measures that Texas has experience with at this time are cross tie cables and neoprene rings. The neoprene rings do not appear to offer a measurable amount of dampening, and

based on the department's experience should not be considered as a primary damping mechanism. The cross tie system that the department has employed has been effective in reducing the extreme vibration events, but vibrations of an amplitude that cause concern still occur. Texas is presently installing viscous damping systems of each of the cable stay bridges in the state. On the Fred Hartman Bridge these will be installed in conjunction with cross tie cables. It is hoped that this combination will effectively eliminate the occurrence and amplitude of any vibrations.

Q8: Please comment on the effectiveness of any sensor-based, long-term monitoring systems for stay cables that you may be familiar with. Examples include acoustic monitoring, vibration monitoring, force measurements, strain measurements, etc.

The department has installed an acoustic monitoring system to identify possible wire breaks at the Fred Hartman Bridge. The system seems to work well and has identified several possible wire breaks. Prior to its installation, the system was tested on a cable mock-up at the Ferguson Structural Lab of the University of Texas at Austin, where research is underway to determine the effects of stay cable vibrations on the fatigue life of the cables. This allowed the department to test the monitoring system to see how accurately it could identify occurrence and location of wire breaks since numerous wire breaks were generated. The correlation between the

NCHRP SYNTHESIS TOPIC 35-07—INSPECTION AND MAINTENANCE OF BRIDGE STAY CABLE SYSTEMS

Veterans Memorial Bridge
Texas

Questionnaire Results
Survey performed in 2004

monitoring system results and the autopsied cables was very good.

Q9: What would you recommend that the cable suppliers incorporate into their systems to make cables more accessible and inspectable?

Current grouted and sheathed systems do not allow for visual inspection. New stay systems (perhaps ungrouted, unsheathed systems consisting of bare corrosion resistant tension members) need to be developed that allow for inspection of the entire stay length. Research is also needed to develop rapid, economical evaluation (NDE) methods to determine conditions of stay cables.

Q10: Do you believe that an up-to-date resource such as a national database of information on stay cable inspection methods, repairs, and testing would be a useful tool?

yes

Q11: What do you see as the single most important problem in stay cable maintenance?

Ability to determine the effectiveness and remaining life of corrosion protection systems for main tension elements. The configuration and construction techniques make evaluation and inspection using non-destructive techniques almost impossible.

Q12: Please comment on any other methods for inspections, testing, monitoring, and repair of stay cable (including conventional methods) that you have found beneficial and are not listed above.

no answer

Additional comments?

NCHRP SYNTHESIS TOPIC 35-07—INSPECTION AND MAINTENANCE OF BRIDGE STAY CABLE SYSTEMS

Fred Hartman Bridge
Texas

Questionnaire Results
Survey performed in 2004

Fred Hartman Bridge

State/Province: *Texas*

Agency: *Texas DOT*

Respondent: *Keith Ramsey*

Span Length: *1,250 ft*

Year Built: *1995*

Q4-4: Type of main tension element (MTE)?

seven-wire steel strand

Q4-5: Coating/treatment on main tension element within free length of cable?

bare

Q4-6: Are the coatings/treatments on main tension element discontinued or removed within the anchorage zone?

N/A—grouted through entire length and anchorage

Q4-7: Type of grout used?

cement–water admixtures

Q4-8: Are filler materials used in the anchorage zone?

yes, other—grout

Q4-9: Type of anchorage?

conical socket with wedges

Q4-10: Do cables go over “saddles” on the pylons?

no

Q4-11: Type of cable sheathing used?

HDPE with PVF Tedlar tape

Q4-12: Have rain–wind-induced cable vibrations been observed on this bridge?

yes

Q4-13: Have MTE corrosion problems been noted?

no

Q4-14: Do cables have neoprene rings near the top and bottom anchorages?

yes

Q4-15: If there are neoprene rings on the cables; have there been any reports of movements of the rings out of their positions?

yes—due to shearing off of retainers

Q4-16: Has moisture been found in any of the internal components of stay cables such as the bottom anchorage areas?

no

Q4-17: Has fatigue of MTE or other components of stay cables been observed?

yes—possible wire breaks have been detected by acoustic monitoring system

Q4-18: Do the cables have viscous dampers installed at deck or tower levels?

yes—retrofitted to correct vibrations; presently being installed

Q4-19: Do the cables have cross cables installed between them?

yes—retrofitted to correct vibrations; presently being installed

Q4-20: Do cables have other dampers (other than viscous or neoprene rings) to control vibrations?

no

Q4-21: Has cracking of the cable sheathing or sheathing connections been noted?

no

Q4-22: Has cracking or misalignment of the guide pipes been noted?

no

Q4-23: If there is protective tape wrapped around the cable sheathing; have there been reports of deterioration of the tape?

yes, minor damage

Q4-24: Have any problems associated with neoprene boots been noted?

no

Q4-25: Types of non-destructive tests that any of the cables on this bridge have been subjected to?

Vibration-based force measurements, used to aid in the design of viscous dampers for the bridge. Performed periodically to compare predampened response to post-dampened response.

NCHRP SYNTHESIS TOPIC 35-07—INSPECTION AND MAINTENANCE OF BRIDGE STAY CABLE SYSTEMS

Fred Hartman Bridge
Texas

Questionnaire Results
Survey performed in 2004

Q4-26: Types of sensor-based, long-term monitoring performed on the cables?

acoustic wire break detection, vibration monitoring, other—have long-term weather monitoring to associate with oscillation events.

Q4-27: Have the cables on this bridge (or any of their components) been repaired?

yes—rewelded and stiffened guide pipe. Replaced initial restrainer system after fatigue and failure of original restrainer cables.

Q4-28: Has the sheathing been partially removed on any of the cables to examine condition of grout (if applicable) and/or the MTE?

yes—sheathing was removed to observe the condition of grout. Grout appeared to be in good/sound condition.

Q4-29: Can the strands or cables be replaced if needed?

yes

Q4-30: Do you have an inspection and maintenance manual for this bridge?

yes

Q5: Based on your experience and in general, do you believe that the current inspection, testing, monitoring, and repair methods available to you for stay cables are effective and adequate?

yes—owners are unable to non-destructively evaluate the condition of stay cables and anchorages.

Q6: Please comment on the effectiveness of any non-destructive test methods for inspections of stay cables that you may be familiar with. These methods include (but are not limited to) ultrasonic testing, magnetic inspections, laser-based force measurements, X-ray imaging, etc. If possible, please comment on issues such as practicality, cost, duration, impact on traffic, and any other factors that you consider important.

TxDOT has employed vibration-based force measurements to refine the model used for designing viscous dampers on each of the cable stay bridges. The technique seemed to give good correlation cable dimensions and damping requirements. The technique requires some traffic control and depending on the number of lanes carried by the structure could produce minor to significant traffic disruption. At least one lane and the shoulder will need to be closed, therefore if the bridge is narrow with a small number of lanes carrying two-way traffic the disruption could be considerable. This could last for several weeks if there are a large number of stays that need to be tested. The cost can run anywhere from \$50,000 to \$75,000 per bridge per test event depending on the size of the structure.

Q7: Please comment on the effectiveness of any cable vibration control measures that you may be familiar with. Examples include

installation of cross cables, viscous dampers, neoprene rings, etc.

The only cable vibration control measures that Texas has experience with at this time are cross tie cables and neoprene rings. The neoprene rings do not appear to offer a measurable amount of dampening, and based on the department's experience should not be considered as a primary damping mechanism. The cross tie system that the department has employed has been effective in reducing the extreme vibration events, but vibrations of an amplitude that cause concern still occur. Texas is presently installing viscous damping systems of each of the cable stay bridges in the state. On the Fred Hartman Bridge these will be installed in conjunction with cross tie cables. It is hoped that this combination will effectively eliminate the occurrence and amplitude of any vibrations.

Q8: Please comment on the effectiveness of any sensor-based, long-term monitoring systems for stay cables that you may be familiar with. Examples include acoustic monitoring, vibration monitoring, force measurements, strain measurements, etc.

The department has installed an acoustic monitoring system to identify possible wire breaks at the Fred Hartman Bridge. The system seems to work well and has identified several possible wire breaks. Prior to its installation, the system was tested on a cable mock-up at the Ferguson Structural Lab of the University of Texas at Austin, where research is underway to determine the effects

NCHRP SYNTHESIS TOPIC 35-07—INSPECTION AND MAINTENANCE OF BRIDGE STAY CABLE SYSTEMS

Fred Hartman Bridge
Texas

Questionnaire Results
Survey performed in 2004

of stay cable vibrations on the fatigue life of the cables. This allowed the department to test the monitoring system to see how accurately it could identify occurrence and location of wire breaks, since numerous wire breaks were generated. The correlation between the monitoring system results and the autopsied cables was very good.

Q9: What would you recommend that the cable suppliers incorporate into their systems to make cables more accessible and inspectable?

Current grouted and sheathed systems do not allow for visual inspection. New stay systems (perhaps ungrouted, unsheathed systems consisting of bare corrosion resistant tension members) need to be developed that allow for inspection of the entire stay length. Research is also needed to develop rapid, economical evaluation (NDE) methods to determine conditions of stay cables.

Q10: Do you believe that an up-to-date resource such as a national database of information on stay cable inspection methods, repairs, and testing would be a useful tool?

yes

Q11: What do you see as the single most important problem in stay cable maintenance?

Ability to determine the effectiveness and remaining life of corrosion protection systems for main tension elements. The configuration and construction techniques make evaluation and inspection using non-destructive techniques almost impossible.

Q12: Please comment on any other methods for inspections, testing, monitoring, and repair of stay cable (including conventional methods) that you have found beneficial and are not listed above.

no answer

Additional comments?

NCHRP SYNTHESIS TOPIC 35-07—INSPECTION AND MAINTENANCE OF BRIDGE STAY CABLE SYSTEMS

*I-295 over James River (Varina–Enon Bridge)
Virginia*

*Questionnaire Results
Survey performed in 2004*

***I-295 over James River
(Varina–Enon Bridge)***

State/Province: *Virginia*

Agency: *VDOT*

Respondent: *James M. Fariss*

Span Length: *630 ft*

Year Built: *1990*

Q4-4: Type of main tension element (MTE)?

seven-wire steel strand

Q4-5: Coating/treatment on main tension element within free length of cable?

bare

Q4-6: Are the coatings/treatments on main tension element discontinued or removed within the anchorage zone?

N/A

Q4-7: Type of grout used?

cement–water admixtures

Q4-8: Are filler materials used in the anchorage zone?

yes, grout

Q4-9: Type of anchorage?

conical socket with wedges

Q4-10: Do cables go over “saddles” on the pylons?

yes

Q4-11: Type of cable sheathing used?

HDPE with PVF Tedlar tape

Q4-12: Have rain–wind-induced cable vibrations been observed on this bridge?

Not known—no such vibrations have been observed on the Varina–Enon Bridge.

Q4-13: Have MTE corrosion problems been noted?

not known

Q4-14: Do cables have neoprene rings near the top and bottom anchorages?

yes—only at the bottom anchorages since the stays are continuous over the pylons

Q4-15: If there are neoprene rings on the cables; have there been any reports of movements of the rings out of their positions?

yes—due to other reasons. Due to the misalignment of stay and guide pipes and no positive restraint was provided to keep neoprene ring from moving outward.

Q4-16: Has moisture been found in any of the internal components of stay cables such as the bottom anchorage areas?

no

Q4-17: Has fatigue of MTE or other components of stay cables been observed?

no—forces obtained in the initial in-depth inspection indicated a good correlation with the designer's predicted forces.

Q4-18: Do the cables have viscous dampers installed at deck or tower levels?

no—details are included in the maintenance manual (Appendix F) as an alternate stay damper system.

Q4-19: Do the cables have cross cables installed between them?

no

Q4-20: Do cables have other dampers (other than viscous or neoprene rings) to control vibrations?

no

Q4-21: Has cracking of the cable sheathing or sheathing connections been noted?

no

Q4-22: Has cracking or misalignment of the guide pipes been noted?

yes, misalignment

Q4-23: If there is protective tape wrapped around the cable sheathing; have there been reports of deterioration of the tape?

no

Q4-24: Have any problems associated with neoprene boots been noted?

yes—minor cracks and tears have been noted in 6 of the 52 neoprene boots.

NCHRP SYNTHESIS TOPIC 35-07—INSPECTION AND MAINTENANCE OF BRIDGE STAY CABLE SYSTEMS

**I-295 over James River (Varina–Enon Bridge)
Virginia**

**Questionnaire Results
Survey performed in 2004**

Q4-25: Types of non-destructive tests that any of the cables on this bridge have been subjected to?

Vibration-based force measurements. Tension force measurement tests were performed by Construction Technology Laboratory, Inc. (CTL) in April 1999.

Q4-26: Types of sensor-based, long-term monitoring performed on the cables?

not known

Q4-27: Have the cables on this bridge (or any of their components) been repaired?

no

Q4-28: Has the sheathing been partially removed on any of the cables to examine condition of grout (if applicable) and/or the MTE?

no

Q4-29: Can the strands or cables be replaced if needed?

yes

Q4-30: Do you have an inspection and maintenance manual for this bridge?

yes

Q5: Based on your experience and in general, do you believe that the current inspection, testing, monitoring, and repair methods available to you for stay cables are effective and adequate?

yes

Q6: Please comment on the effectiveness of any non-destructive test methods for inspections of stay cables that you may be familiar with. These methods include (but are not limited to) ultrasonic testing, magnetic inspections, laser-based force measurements, X-ray imaging, etc. If possible, please comment on issues such as practicality, cost, duration, impact on traffic, and any other factors that you consider important.

Laser-based force measurements were utilized in the initial in-depth inspection of this bridge in 1999. The cost incurred was approximately \$35,000, with minimum impact on traffic.

Q7: Please comment on the effectiveness of any cable vibration control measures that you may be familiar with. Examples include installation of cross cables, viscous dampers, neoprene rings, etc.

Neoprene rings were installed on the Varina–Enon Bridge as the primary stay damping system. This is a relatively cost-effective system, and appears to be performing satisfactorily on this bridge. We have experienced some difficulty in the installation and removal of these rings. Details of an alternate stay damping system utilizing shock absorbers have been included in the Manual for Inspection and Maintenance of the Varina–Enon Bridge.

Q8: Please comment on the effectiveness of any sensor-based, long-term monitoring systems for stay cables that you may be familiar with. Examples include acoustic

monitoring, vibration monitoring, force measurements, strain measurements, etc.

no comments

Q9: What would you recommend that the cable suppliers incorporate into their systems to make cables more accessible and inspectable?

no comments

Q10: Do you believe that an up-to-date resource such as a national database of information on stay cable inspection methods, repairs, and testing would be a useful tool?

yes

Q11: What do you see as the single most important problem in stay cable maintenance?

Lack of familiarity with this type of construction by the department's staff, which requires assistance from the consultant community in the inspection of these elements.

Q12: Please comment on any other methods for inspections, testing, monitoring, and repair of stay cable (including conventional methods) that you have found beneficial and are not listed above.

no answer

Additional comments?

NCHRP SYNTHESIS TOPIC 35-07—INSPECTION AND MAINTENANCE OF BRIDGE STAY CABLE SYSTEMS

Gum Street—Kennewick, WA
Washington

Questionnaire Results
Survey performed in 2004

Gum Street—Kennewick, WA

State/Province: *Washington*

Agency: *Washington State DOT*

Respondent: *David Bruce*

Span Length: *981 ft*

Year Built: *1978*

Q4-4: Type of main tension element (MTE)?

steel wire

Q4-5: Coating/treatment on main tension element within free length of cable?

bare

Q4-6: Are the coatings/treatments on main tension element discontinued or removed within the anchorage zone?

N/A

Q4-7: Type of grout used?

cement–water

Q4-8: Are filler materials used in the anchorage zone?

yes, grease

Q4-9: Type of anchorage?

“Hi-Am” type

Q4-10: Do cables go over “saddles” on the pylons?

no

Q4-11: Type of cable sheathing used?

HDPE with PVF Tedlar tape

Q4-12: Have rain–wind-induced cable vibrations been observed on this bridge?

no

Q4-13: Have MTE corrosion problems been noted?

no

Q4-14: Do cables have neoprene rings near the top and bottom anchorages?

not known

Q4-15: If there are neoprene rings on the cables; have there been any reports of movements of the rings out of their positions?

no, not known

Q4-16: Has moisture been found in any of the internal components of stay cables such as the bottom anchorage areas?

no

Q4-17: Has fatigue of MTE or other components of stay cables been observed?

no

Q4-18: Do the cables have viscous dampers installed at deck or tower levels?

no

Q4-19: Do the cables have cross cables installed between them?

no

Q4-20: Do cables have other dampers (other than viscous or neoprene rings) to control vibrations?

no

Q4-21: Has cracking of the cable sheathing or sheathing connections been noted?

no

Q4-22: Has cracking or misalignment of the guide pipes been noted?

no

Q4-23: If there is protective tape wrapped around the cable sheathing; have there been reports of deterioration of the tape?

yes, extensive damage

Q4-24: Have any problems associated with neoprene boots been noted?

yes

Q4-25: Types of non-destructive tests that any of the cables on this bridge have been subjected to?

magnetic

Q4-26: Types of sensor-based, long-term monitoring performed on the cables?

not performed

Q4-27: Have the cables on this bridge (or any of their components) been repaired?

no

NCHRP SYNTHESIS TOPIC 35-07—INSPECTION AND MAINTENANCE OF BRIDGE STAY CABLE SYSTEMS

**Gum Street—Kennewick, WA
Washington**

**Questionnaire Results
Survey performed in 2004**

Q4-28: Has the sheathing been partially removed on any of the cables to examine condition of grout (if applicable) and/or the MTE?

no

Q4-29: Can the strands or cables be replaced if needed?

not known

Q4-30: Do you have an inspection and maintenance manual for this bridge?

yes

Q5: Based on your experience and in general, do you believe that the current inspection, testing, monitoring, and repair methods available to you for stay cables are effective and adequate?

yes

Q6: Please comment on the effectiveness of any non-destructive test methods for inspections of stay cables that you may be familiar with. These methods include (but are not limited to) ultrasonic testing, magnetic inspections, laser-based force measurements, X-ray imaging, etc. If possible, please comment on issues such as practicality, cost, duration, impact on traffic, and any other factors that you consider important.

N/A

Q7: Please comment on the effectiveness of any cable vibration control measures that you may be familiar with. Examples include

installation of cross cables, viscous dampers, neoprene rings, etc.

N/A

Q8: Please comment on the effectiveness of any sensor-based, long-term monitoring systems for stay cables that you may be familiar with. Examples include acoustic monitoring, vibration monitoring, force measurements, strain measurements, etc.

N/A

Q9: What would you recommend that the cable suppliers incorporate into their systems to make cables more accessible and inspectable?

unknown

Q10: Do you believe that an up-to-date resource such as a national database of information on stay cable inspection methods, repairs, and testing would be a useful tool?

yes

Q11: What do you see as the single most important problem in stay cable maintenance?

none yet

Q12: Please comment on any other methods for inspections, testing, monitoring, and repair of stay cable (including conventional methods) that you have found beneficial and are not listed above.

N/A

Additional comments?

NCHRP SYNTHESIS TOPIC 35-07—INSPECTION AND MAINTENANCE OF BRIDGE STAY CABLE SYSTEMS

Thea–Foss Tacoma, WA
Washington

Questionnaire Results
Survey performed in 2004

Thea–Foss Tacoma, WA

State/Province: **Washington**

Agency: **Washington State DOT**

Respondent: **David Bruce**

Span Length: **375 ft**

Year Built: **1996**

Q4-4: Type of main tension element (MTE)?

seven-wire steel strand

Q4-5: Coating/treatment on main tension element within free length of cable?

bare

Q4-6: Are the coatings/treatments on main tension element discontinued or removed within the anchorage zone?

N/A

Q4-7: Type of grout used?

cement–water

Q4-8: Are filler materials used in the anchorage zone?

yes, grease

Q4-9: Type of anchorage?

wedges

Q4-10: Do cables go over “saddles” on the pylons?

no

Q4-11: Type of cable sheathing used?

no answer

Q4-12: Have rain–wind-induced cable vibrations been observed on this bridge?

no

Q4-13: Have MTE corrosion problems been noted?

no

Q4-14: Do cables have neoprene rings near the top and bottom anchorages?

yes

Q4-15: If there are neoprene rings on the cables; have there been any reports of movements of the rings out of their positions?

no, not known

Q4-16: Has moisture been found in any of the internal components of stay cables such as the bottom anchorage areas?

no

Q4-17: Has fatigue of MTE or other components of stay cables been observed?

no

Q4-18: Do the cables have viscous dampers installed at deck or tower levels?

no

Q4-19: Do the cables have cross cables installed between them?

no

Q4-20: Do cables have other dampers (other than viscous or neoprene rings) to control vibrations?

no

Q4-21: Has cracking of the cable sheathing or sheathing connections been noted?

no

Q4-22: Has cracking or misalignment of the guide pipes been noted?

no

Q4-23: If there is protective tape wrapped around the cable sheathing; have there been reports of deterioration of the tape?

yes, minor damage

Q4-24: Have any problems associated with neoprene boots been noted?

no

Q4-25: Types of non-destructive tests that any of the cables on this bridge have been subjected to?

not performed

Q4-26: Types of sensor-based, long-term monitoring performed on the cables?

not performed

Q4-27: Have the cables on this bridge (or any of their components) been repaired?

no

NCHRP SYNTHESIS TOPIC 35-07—INSPECTION AND MAINTENANCE OF BRIDGE STAY CABLE SYSTEMS

Thea-Foss Tacoma, WA
Washington

Questionnaire Results
Survey performed in 2004

Q4-28: Has the sheathing been partially removed on any of the cables to examine condition of grout (if applicable) and/or the MTE?

no

Q4-29: Can the strands or cables be replaced if needed?

not known

Q4-30: Do you have an inspection and maintenance manual for this bridge?

yes

Q5: Based on your experience and in general, do you believe that the current inspection, testing, monitoring, and repair methods available to you for stay cables are effective and adequate?

yes

Q6: Please comment on the effectiveness of any non-destructive test methods for inspections of stay cables that you may be familiar with. These methods include (but are not limited to) ultrasonic testing, magnetic inspections, laser-based force measurements, X-ray imaging, etc. If possible, please comment on issues such as practicality, cost, duration, impact on traffic, and any other factors that you consider important.

N/A

Q7: Please comment on the effectiveness of any cable vibration control measures that you may be familiar with. Examples include

installation of cross cables, viscous dampers, neoprene rings, etc.

N/A

Q8: Please comment on the effectiveness of any sensor-based, long-term monitoring systems for stay cables that you may be familiar with. Examples include acoustic monitoring, vibration monitoring, force measurements, strain measurements, etc.

N/A

Q9: What would you recommend that the cable suppliers incorporate into their systems to make cables more accessible and inspectable?

unknown

Q10: Do you believe that an up-to-date resource such as a national database of information on stay cable inspection methods, repairs, and testing would be a useful tool?

yes

Q11: What do you see as the single most important problem in stay cable maintenance?

none yet

Q12: Please comment on any other methods for inspections, testing, monitoring, and repair of stay cable (including conventional methods) that you have found beneficial and are not listed above.

N/A

Additional comments?

NCHRP SYNTHESIS TOPIC 35-07—INSPECTION AND MAINTENANCE OF BRIDGE STAY CABLE SYSTEMS

*Sixth Street Viaduct, North Cable Stay
Wisconsin/Milwaukee*

*Questionnaire Results
Survey performed in 2004*

***Sixth Street Viaduct, North
Cable Stay***

State/Province: *Wisconsin/Milwaukee*

Agency: *City of Milwaukee*

Respondent: *Craig Liberto*

Span Length: *195 ft*

Year Built: *2003*

Q4-4: Type of main tension element (MTE)?

seven-wire steel strand

Q4-5: Coating/treatment on main tension element within free length of cable?

greased-and-sheathed

Q4-6: Are the coatings/treatments on main tension element discontinued or removed within the anchorage zone?

yes—removed within anchor zone

Q4-7: Type of grout used?

grout not used

Q4-8: Are filler materials used in the anchorage zone?

yes—grease; greased at butt end and top end

Q4-9: Type of anchorage?

conical socket with wedges

Q4-10: Do cables go over “saddles” on the pylons?

no

Q4-11: Type of cable sheathing used?

UV-resistant HDPE with spiral on surface, white co-extruded HDPE

Q4-12: Have rain–wind-induced cable vibrations been observed on this bridge?

no—vibration not expected for this small cable-stayed bridge.

Q4-13: Have MTE corrosion problems been noted?

no

Q4-14: Do cables have neoprene rings near the top and bottom anchorages?

no at top, yes at bottom

Q4-15: If there are neoprene rings on the cables; have there been any reports of movements of the rings out of their positions?

no, not known

Q4-16: Has moisture been found in any of the internal components of stay cables such as the bottom anchorage areas?

no

Q4-17: Has fatigue of MTE or other components of stay cables been observed?

no

Q4-18: Do the cables have viscous dampers installed at deck or tower levels?

no

Q4-19: Do the cables have cross cables installed between them?

no

Q4-20: Do cables have other dampers (other than viscous or neoprene rings) to control vibrations?

no

Q4-21: Has cracking of the cable sheathing or sheathing connections been noted?

no

Q4-22: Has cracking or misalignment of the guide pipes been noted?

yes—misalignment; top guide pipes not concentric w/PE is the only misalignment

Q4-23: If there is protective tape wrapped around the cable sheathing; have there been reports of deterioration of the tape?

no

Q4-24: Have any problems associated with neoprene boots been noted?

no

Q4-25: Types of non-destructive tests that any of the cables on this bridge have been subjected to?

Not performed. By requirements of supplier, full-scale stay cable fatigue tests by Construction Technology Laboratories in Skokie, Illinois and Technical University of Munich; no wire breaks during 2 million cycle fatigue tests. During reload and static tests,

NCHRP SYNTHESIS TOPIC 35-07—INSPECTION AND MAINTENANCE OF BRIDGE STAY CABLE SYSTEMS

*Sixth Street Viaduct, North Cable Stay
Wisconsin/Milwaukee*

*Questionnaire Results
Survey performed in 2004*

failed to meet minimum tensile force of 95% GUTS (only 90%). Therefore, added strands at all locations.

Q4-26: Types of sensor-based, long-term monitoring performed on the cables?

not performed

Q4-27: Have the cables on this bridge (or any of their components) been repaired?

no

Q4-28: Has the sheathing been partially removed on any of the cables to examine condition of grout (if applicable) and/or the MTE?

no

Q4-29: Can the strands or cables be replaced if needed?

yes

Q4-30: Do you have an inspection and maintenance manual for this bridge?

yes

Q5: Based on your experience and in general, do you believe that the current inspection, testing, monitoring, and repair methods available to you for stay cables are effective and adequate?

not known, no previous experience with cable-stayed structure

Q6: Please comment on the effectiveness of any non-destructive test methods for inspections of stay cables that you may be

familiar with. These methods include (but are not limited to) ultrasonic testing, magnetic inspections, laser-based force measurements, X-ray imaging, etc. If possible, please comment on issues such as practicality, cost, duration, impact on traffic, and any other factors that you consider important.

City inspection forces are neither qualified nor equipped for non-destructive testing. Four single strands are to be removed (one at each pylon) for inspection for rust every 10 years starting in year 2014.

Q7: Please comment on the effectiveness of any cable vibration control measures that you may be familiar with. Examples include installation of cross cables, viscous dampers, neoprene rings, etc.

no vibrations noted

Q8: Please comment on the effectiveness of any sensor-based, long-term monitoring systems for stay cables that you may be familiar with. Examples include acoustic monitoring, vibration monitoring, force measurements, strain measurements, etc.

not applicable

Q9: What would you recommend that the cable suppliers incorporate into their systems to make cables more accessible and inspectable?

no answer

Q10: Do you believe that an up-to-date resource such as a national database of information on stay cable inspection methods, repairs, and testing would be a useful tool?

yes

Q11: What do you see as the single most important problem in stay cable maintenance?

Cannot inspect cables without pulling strand every 10 years.

Q12: Please comment on any other methods for inspections, testing, monitoring, and repair of stay cable (including conventional methods) that you have found beneficial and are not listed above.

Four strands (one at each pylon) will be removed every 10 years starting in 2014 to check for corrosion/rusting.

Additional comments?

NCHRP SYNTHESIS TOPIC 35-07—INSPECTION AND MAINTENANCE OF BRIDGE STAY CABLE SYSTEMS

*Sixth Street Viaduct, South Cable Stay
Wisconsin/Milwaukee*

*Questionnaire Results
Survey performed in 2004*

**Sixth Street Viaduct, South
Cable Stay**

State/Province: *Wisconsin/Milwaukee*

Agency: *City of Milwaukee*

Respondent: *Craig Liberto*

Span Length: *195 ft*

Year Built: *2003*

Q4-4: Type of main tension element (MTE)?

seven-wire steel strand

Q4-5: Coating/treatment on main tension element within free length of cable?

greased-and-sheathed

Q4-6: Are the coatings/treatments on main tension element discontinued or removed within the anchorage zone?

yes—removed within anchor zone

Q4-7: Type of grout used?

grout not used

Q4-8: Are filler materials used in the anchorage zone?

yes—grease; greased at butt end and top end

Q4-9: Type of anchorage?

conical socket with wedges

Q4-10: Do cables go over “saddles” on the pylons?

no

Q4-11: Type of cable sheathing used?

UV-resistant HDPE with spiral on surface, white co-extruded HDPE.

Q4-12: Have rain–wind-induced cable vibrations been observed on this bridge?

no—vibration not expected for this small cable-stayed bridge.

Q4-13: Have MTE corrosion problems been noted?

no

Q4-14: Do cables have neoprene rings near the top and bottom anchorages?

no at top, yes at bottom

Q4-15: If there are neoprene rings on the cables; have there been any reports of movements of the rings out of their positions?

no, not known

Q4-16: Has moisture been found in any of the internal components of stay cables such as the bottom anchorage areas?

no

Q4-17: Has fatigue of MTE or other components of stay cables been observed?

no

Q4-18: Do the cables have viscous dampers installed at deck or tower levels?

no

Q4-19: Do the cables have cross cables installed between them?

no

Q4-20: Do cables have other dampers (other than viscous or neoprene rings) to control vibrations?

no

Q4-21: Has cracking of the cable sheathing or sheathing connections been noted?

no

Q4-22: Has cracking or misalignment of the guide pipes been noted?

yes—misalignment, top guide pipes not concentric with PE is the only misalignment

Q4-23: If there is protective tape wrapped around the cable sheathing; have there been reports of deterioration of the tape?

no

Q4-24: Have any problems associated with neoprene boots been noted?

no

Q4-25: Types of non-destructive tests that any of the cables on this bridge have been subjected to?

Not performed. By requirements of supplier, full-scale stay cable fatigue tests by Construction Technology Laboratories in Skokie, Illinois and Technical University of Munich; no wire breaks during 2 million cycle fatigue tests. During reload and static tests,

NCHRP SYNTHESIS TOPIC 35-07—INSPECTION AND MAINTENANCE OF BRIDGE STAY CABLE SYSTEMS

*Sixth Street Viaduct, South Cable Stay
Wisconsin/Milwaukee*

*Questionnaire Results
Survey performed in 2004*

failed to meet minimum tensile force of 95% GUTS (only 90%). Therefore, added strands at all locations.

Q4-26: Types of sensor-based, long-term monitoring performed on the cables?

not performed

Q4-27: Have the cables on this bridge (or any of their components) been repaired?

no

Q4-28: Has the sheathing been partially removed on any of the cables to examine condition of grout (if applicable) and/or the MTE?

no

Q4-29: Can the strands or cables be replaced if needed?

yes

Q4-30: Do you have an inspection and maintenance manual for this bridge?

yes

Q5: Based on your experience and in general, do you believe that the current inspection, testing, monitoring, and repair methods available to you for stay cables are effective and adequate?

not known, no previous experience with cable-stayed structure

Q6: Please comment on the effectiveness of any non-destructive test methods for inspections of stay cables that you may be

familiar with. These methods include (but are not limited to) ultrasonic testing, magnetic inspections, laser-based force measurements, X-ray imaging, etc. If possible, please comment on issues such as practicality, cost, duration, impact on traffic, and any other factors that you consider important.

City inspection forces are neither qualified or equipped for non-destructive testing. Four single strands are to be removed (one at each pylon) for inspection for rust every 10 years starting in year 2014.

Q7: Please comment on the effectiveness of any cable vibration control measures that you may be familiar with. Examples include installation of cross cables, viscous dampers, neoprene rings, etc.

no vibrations noted

Q8: Please comment on the effectiveness of any sensor-based, long-term monitoring systems for stay cables that you may be familiar with. Examples include acoustic monitoring, vibration monitoring, force measurements, strain measurements, etc.

not applicable

Q9: What would you recommend that the cable suppliers incorporate into their systems to make cables more accessible and inspectable?

no answer

Q10: Do you believe that an up-to-date resource such as a national database of information on stay cable inspection methods, repairs, and testing would be a useful tool?

yes

Q11: What do you see as the single most important problem in stay cable maintenance?

Cannot inspect cables without pulling strand every 10 years.

Q12: Please comment on any other methods for inspections, testing, monitoring, and repair of stay cable (including conventional methods) that you have found beneficial and are not listed above.

Four strands (one at each pylon) will be removed every 10 years starting in 2014 to check for corrosion/rusting.

Additional comments?

NCHRP SYNTHESIS TOPIC 35-07—INSPECTION AND MAINTENANCE OF BRIDGE STAY CABLE SYSTEMS

Prince's Island (Pedestrian)
 Alberta/Calgary, Canada

Questionnaire Results
 Survey performed in 2004

Prince's Island (Pedestrian)

State/Province: *Alberta/Calgary, Canada*

Agency: *City of Calgary*

Respondent: *Peter Wilson*

Span Length: *220 ft*

Year Built: *1972*

Q4-4: Type of main tension element (MTE)?

steel wire

Q4-5: Coating/treatment on main tension element within free length of cable?

galvanized steel

Q4-6: Are the coatings/treatments on main tension element discontinued or removed within the anchorage zone?

not known

Q4-7: Type of grout used?

grout not used

Q4-8: Are filler materials used in the anchorage zone?

no filler

Q4-9: Type of anchorage?

conical socket with wedges

Q4-10: Do cables go over “saddles” on the pylons?

no

Q4-11: Type of cable sheathing used?

no sheathing

Q4-12: Have rain–wind-induced cable vibrations been observed on this bridge?

yes

Q4-13: Have MTE corrosion problems been noted?

not known

Q4-14: Do cables have neoprene rings near the top and bottom anchorages?

no

Q4-15: If there are neoprene rings on the cables; have there been any reports of movements of the rings out of their positions?

not applicable

Q4-16: Has moisture been found in any of the internal components of stay cables such as the bottom anchorage areas?

not tested

Q4-17: Has fatigue of MTE or other components of stay cables been observed?

not known

Q4-18: Do the cables have viscous dampers installed at deck or tower levels?

no

Q4-19: Do the cables have cross cables installed between them?

no

Q4-20: Do cables have other dampers (other than viscous or neoprene rings) to control vibrations?

no

Q4-21: Has cracking of the cable sheathing or sheathing connections been noted?

not applicable

Q4-22: Has cracking or misalignment of the guide pipes been noted?

not applicable

Q4-23: If there is protective tape wrapped around the cable sheathing; have there been reports of deterioration of the tape?

not applicable

Q4-24: Have any problems associated with neoprene boots been noted?

not known

Q4-25: Types of non-destructive tests that any of the cables on this bridge have been subjected to?

not performed

Q4-26: Types of sensor-based, long-term monitoring performed on the cables?

not performed

Q4-27: Have the cables on this bridge (or any of their components) been repaired?

no

NCHRP SYNTHESIS TOPIC 35-07—INSPECTION AND MAINTENANCE OF BRIDGE STAY CABLE SYSTEMS

Prince's Island (Pedestrian)
Alberta/Calgary, Canada

Questionnaire Results
Survey performed in 2004

Q4-28: Has the sheathing been partially removed on any of the cables to examine condition of grout (if applicable) and/or the MTE?

not applicable

Q4-29: Can the strands or cables be replaced if needed?

no

Q4-30: Do you have an inspection and maintenance manual for this bridge?

no

Q5: Based on your experience and in general, do you believe that the current inspection, testing, monitoring, and repair methods available to you for stay cables are effective and adequate?

yes

Q6: Please comment on the effectiveness of any non-destructive test methods for inspections of stay cables that you may be familiar with. These methods include (but are not limited to) ultrasonic testing, magnetic inspections, laser-based force measurements, X-ray imaging, etc. If possible, please comment on issues such as practicality, cost, duration, impact on traffic, and any other factors that you consider important.

no answer

Q7: Please comment on the effectiveness of any cable vibration control measures that you may be familiar with. Examples include

installation of cross cables, viscous dampers, neoprene rings, etc.

The installation of cross cables has greatly reduced the cable vibration.

Q8: Please comment on the effectiveness of any sensor-based, long-term monitoring systems for stay cables that you may be familiar with. Examples include acoustic monitoring, vibration monitoring, force measurements, strain measurements, etc.

Have not used vibration monitoring on a long-term basis. Has only been used for short durations to determine frequency and magnitude, etc.

Q9: What would you recommend that the cable suppliers incorporate into their systems to make cables more accessible and inspectable?

no answer

Q10: Do you believe that an up-to-date resource such as a national database of information on stay cable inspection methods, repairs, and testing would be a useful tool?

yes

Q11: What do you see as the single most important problem in stay cable maintenance?

Access for inspection and actual testing

Q12: Please comment on any other methods for inspections, testing, monitoring, and repair of stay cable (including conventional methods) that you have found beneficial and are not listed above.

no answer

Additional comments?

The five bridges identified are all pedestrian structures; three over water and two over roadways.

NCHRP SYNTHESIS TOPIC 35-07—INSPECTION AND MAINTENANCE OF BRIDGE STAY CABLE SYSTEMS

*Carburn Park (Pedestrian)
Alberta/Calgary, Canada*

*Questionnaire Results
Survey performed in 2004*

Carburn Park (Pedestrian)

State/Province: *Alberta/Calgary, Canada*

Agency: *City of Calgary*

Respondent: *Peter Wilson*

Span Length: *262 ft*

Year Built: *1982*

Q4-4: Type of main tension element (MTE)?

steel bar or threadbar

Q4-5: Coating/treatment on main tension element within free length of cable?

galvanized steel

Q4-6: Are the coatings/treatments on main tension element discontinued or removed within the anchorage zone?

not known

Q4-7: Type of grout used?

grout not used

Q4-8: Are filler materials used in the anchorage zone?

no filler

Q4-9: Type of anchorage?

other—threaded couplers

Q4-10: Do cables go over “saddles” on the pylons?

no

Q4-11: Type of cable sheathing used?

no sheathing

Q4-12: Have rain–wind-induced cable vibrations been observed on this bridge?

not known

Q4-13: Have MTE corrosion problems been noted?

not known

Q4-14: Do cables have neoprene rings near the top and bottom anchorages?

no

Q4-15: If there are neoprene rings on the cables; have there been any reports of movements of the rings out of their positions?

not applicable

Q4-16: Has moisture been found in any of the internal components of stay cables such as the bottom anchorage areas?

not tested

Q4-17: Has fatigue of MTE or other components of stay cables been observed?

no

Q4-18: Do the cables have viscous dampers installed at deck or tower levels?

no

Q4-19: Do the cables have cross cables installed between them?

no

Q4-20: Do cables have other dampers (other than viscous or neoprene rings) to control vibrations?

no

Q4-21: Has cracking of the cable sheathing or sheathing connections been noted?

not applicable

Q4-22: Has cracking or misalignment of the guide pipes been noted?

not applicable

Q4-23: If there is protective tape wrapped around the cable sheathing; have there been reports of deterioration of the tape?

not applicable

Q4-24: Have any problems associated with neoprene boots been noted?

not known

Q4-25: Types of non-destructive tests that any of the cables on this bridge have been subjected to?

not performed

Q4-26: Types of sensor-based, long-term monitoring performed on the cables?

not performed

Q4-27: Have the cables on this bridge (or any of their components) been repaired?

no

NCHRP SYNTHESIS TOPIC 35-07—INSPECTION AND MAINTENANCE OF BRIDGE STAY CABLE SYSTEMS

**Carburn Park (Pedestrian)
Alberta/Calgary, Canada**

**Questionnaire Results
Survey performed in 2004**

Q4-28: Has the sheathing been partially removed on any of the cables to examine condition of grout (if applicable) and/or the MTE?

not applicable

Q4-29: Can the strands or cables be replaced if needed?

yes

Q4-30: Do you have an inspection and maintenance manual for this bridge?

no

Q5: Based on your experience and in general, do you believe that the current inspection, testing, monitoring, and repair methods available to you for stay cables are effective and adequate?

yes

Q6: Please comment on the effectiveness of any non-destructive test methods for inspections of stay cables that you may be familiar with. These methods include (but are not limited to) ultrasonic testing, magnetic inspections, laser-based force measurements, X-ray imaging, etc. If possible, please comment on issues such as practicality, cost, duration, impact on traffic, and any other factors that you consider important.

no answer

Q7: Please comment on the effectiveness of any cable vibration control measures that you may be familiar with. Examples include

installation of cross cables, viscous dampers, neoprene rings, etc.

The installation of cross cables has greatly reduced the cable vibration.

Q8: Please comment on the effectiveness of any sensor-based, long-term monitoring systems for stay cables that you may be familiar with. Examples include acoustic monitoring, vibration monitoring, force measurements, strain measurements, etc.

Have not used vibration monitoring on a long-term basis. Has only been used for short durations to determine frequency and magnitude, etc.

Q9: What would you recommend that the cable suppliers incorporate into their systems to make cables more accessible and inspectable?

no answer

Q10: Do you believe that an up-to-date resource such as a national database of information on stay cable inspection methods, repairs, and testing would be a useful tool?

yes

Q11: What do you see as the single most important problem in stay cable maintenance?

Access for inspection and actual testing

Q12: Please comment on any other methods for inspections, testing, monitoring, and repair of stay cable (including conventional methods) that you have found beneficial and are not listed above.

no answer

Additional comments?

The five bridges identified are all pedestrian structures; three over water and two over roadways.

NCHRP SYNTHESIS TOPIC 35-07—INSPECTION AND MAINTENANCE OF BRIDGE STAY CABLE SYSTEMS

*McMahon (Pedestrian)
Alberta/Calgary, Canada*

*Questionnaire Results
Survey performed in 2004*

McMahon (Pedestrian)

State/Province: *Alberta/Calgary, Canada*

Agency: *City of Calgary*

Respondent: *Peter Wilson*

Span Length: *154 ft*

Year Built: *1987*

Q4-4: Type of main tension element (MTE)?

steel bar or threadbar

Q4-5: Coating/treatment on main tension element within free length of cable?

galvanized steel

Q4-6: Are the coatings/treatments on main tension element discontinued or removed within the anchorage zone?

no

Q4-7: Type of grout used?

grout not used

Q4-8: Are filler materials used in the anchorage zone?

no filler

Q4-9: Type of anchorage?

other, threaded coupler

Q4-10: Do cables go over “saddles” on the pylons?

no

Q4-11: Type of cable sheathing used?

no sheathing

Q4-12: Have rain–wind-induced cable vibrations been observed on this bridge?

no

Q4-13: Have MTE corrosion problems been noted?

not known

Q4-14: Do cables have neoprene rings near the top and bottom anchorages?

no

Q4-15: If there are neoprene rings on the cables; have there been any reports of movements of the rings out of their positions?

not applicable

Q4-16: Has moisture been found in any of the internal components of stay cables such as the bottom anchorage areas?

not tested

Q4-17: Has fatigue of MTE or other components of stay cables been observed?

no

Q4-18: Do the cables have viscous dampers installed at deck or tower levels?

no

Q4-19: Do the cables have cross cables installed between them?

yes, from the beginning

Q4-20: Do cables have other dampers (other than viscous or neoprene rings) to control vibrations?

no

Q4-21: Has cracking of the cable sheathing or sheathing connections been noted?

not applicable

Q4-22: Has cracking or misalignment of the guide pipes been noted?

not applicable

Q4-23: If there is protective tape wrapped around the cable sheathing; have there been reports of deterioration of the tape?

not applicable

Q4-24: Have any problems associated with neoprene boots been noted?

not known

Q4-25: Types of non-destructive tests that any of the cables on this bridge have been subjected to?

not performed

Q4-26: Types of sensor-based, long-term monitoring performed on the cables?

not performed

Q4-27: Have the cables on this bridge (or any of their components) been repaired?

no

NCHRP SYNTHESIS TOPIC 35-07—INSPECTION AND MAINTENANCE OF BRIDGE STAY CABLE SYSTEMS

*McMahon (Pedestrian)
Alberta/Calgary, Canada*

*Questionnaire Results
Survey performed in 2004*

Q4-28: Has the sheathing been partially removed on any of the cables to examine condition of grout (if applicable) and/or the MTE?

not applicable

Q4-29: Can the strands or cables be replaced if needed?

yes

Q4-30: Do you have an inspection and maintenance manual for this bridge?

no

Q5: Based on your experience and in general, do you believe that the current inspection, testing, monitoring, and repair methods available to you for stay cables are effective and adequate?

yes

Q6: Please comment on the effectiveness of any non-destructive test methods for inspections of stay cables that you may be familiar with. These methods include (but are not limited to) ultrasonic testing, magnetic inspections, laser-based force measurements, X-ray imaging, etc. If possible, please comment on issues such as practicality, cost, duration, impact on traffic, and any other factors that you consider important.

no answer

Q7: Please comment on the effectiveness of any cable vibration control measures that you may be familiar with. Examples include

installation of cross cables, viscous dampers, neoprene rings, etc.

The installation of cross cables has greatly reduced the cable vibration.

Q8: Please comment on the effectiveness of any sensor-based, long-term monitoring systems for stay cables that you may be familiar with. Examples include acoustic monitoring, vibration monitoring, force measurements, strain measurements, etc.

Have not used vibration monitoring on a long-term basis. Has only been used for short durations to determine frequency and magnitude, etc.

Q9: What would you recommend that the cable suppliers incorporate into their systems to make cables more accessible and inspectable?

no answer

Q10: Do you believe that an up-to-date resource such as a national database of information on stay cable inspection methods, repairs, and testing would be a useful tool?

yes

Q11: What do you see as the single most important problem in stay cable maintenance?

Access for inspection and actual testing

Q12: Please comment on any other methods for inspections, testing, monitoring, and repair of stay cable (including conventional methods) that you have found beneficial and are not listed above.

no answer

Additional comments?

The five bridges identified are all pedestrian structures; three over water and two over roadways.

NCHRP SYNTHESIS TOPIC 35-07—INSPECTION AND MAINTENANCE OF BRIDGE STAY CABLE SYSTEMS

*Fox Hollow (Pedestrian)
Alberta/Calgary, Canada*

*Questionnaire Results
Survey performed in 2004*

Fox Hollow (Pedestrian)

State/Province: *Alberta/Calgary, Canada*

Agency: *City of Calgary*

Respondent: *Peter Wilson*

Span Length: *148 ft*

Year Built: *1996*

Q4-4: Type of main tension element (MTE)?

steel bar or threadbar

Q4-5: Coating/treatment on main tension element within free length of cable?

galvanized steel

Q4-6: Are the coatings/treatments on main tension element discontinued or removed within the anchorage zone?

no

Q4-7: Type of grout used?

grout not used

Q4-8: Are filler materials used in the anchorage zone?

no filler

Q4-9: Type of anchorage?

other, threaded coupler

Q4-10: Do cables go over “saddles” on the pylons?

no

Q4-11: Type of cable sheathing used?

no sheathing

Q4-12: Have rain–wind-induced cable vibrations been observed on this bridge?

yes

Q4-13: Have MTE corrosion problems been noted?

yes

Q4-14: Do cables have neoprene rings near the top and bottom anchorages?

no

Q4-15: If there are neoprene rings on the cables; have there been any reports of movements of the rings out of their positions?

not applicable

Q4-16: Has moisture been found in any of the internal components of stay cables such as the bottom anchorage areas?

no

Q4-17: Has fatigue of MTE or other components of stay cables been observed?

yes

Q4-18: Do the cables have viscous dampers installed at deck or tower levels?

no

Q4-19: Do the cables have cross cables installed between them?

yes, retrofitted to correct vibrations

Q4-20: Do cables have other dampers (other than viscous or neoprene rings) to control vibrations?

no

Q4-21: Has cracking of the cable sheathing or sheathing connections been noted?

not applicable

Q4-22: Has cracking or misalignment of the guide pipes been noted?

not applicable

Q4-23: If there is protective tape wrapped around the cable sheathing; have there been reports of deterioration of the tape?

not applicable

Q4-24: Have any problems associated with neoprene boots been noted?

no

Q4-25: Types of non-destructive tests that any of the cables on this bridge have been subjected to?

magnetic, ultrasonic, and vibration-based force measurements

Q4-26: Types of sensor-based, long-term monitoring performed on the cables?

not performed

Q4-27: Have the cables on this bridge (or any of their components) been repaired?

yes—Two bars failed and were replaced. One additional bar replaced due to corrosion.

NCHRP SYNTHESIS TOPIC 35-07—INSPECTION AND MAINTENANCE OF BRIDGE STAY CABLE SYSTEMS

*Fox Hollow (Pedestrian)
Alberta/Calgary, Canada*

*Questionnaire Results
Survey performed in 2004*

Q4-28: Has the sheathing been partially removed on any of the cables to examine condition of grout (if applicable) and/or the MTE?

not applicable

Q4-29: Can the strands or cables be replaced if needed?

yes

Q4-30: Do you have an inspection and maintenance manual for this bridge?

no

Q5: Based on your experience and in general, do you believe that the current inspection, testing, monitoring, and repair methods available to you for stay cables are effective and adequate?

yes

Q6: Please comment on the effectiveness of any non-destructive test methods for inspections of stay cables that you may be familiar with. These methods include (but are not limited to) ultrasonic testing, magnetic inspections, laser-based force measurements, X-ray imaging, etc. If possible, please comment on issues such as practicality, cost, duration, impact on traffic, and any other factors that you consider important.

no answer

Q7: Please comment on the effectiveness of any cable vibration control measures that you may be familiar with. Examples include

installation of cross cables, viscous dampers, neoprene rings, etc.

The installation of cross cables has greatly reduced the cable vibration.

Q8: Please comment on the effectiveness of any sensor-based, long-term monitoring systems for stay cables that you may be familiar with. Examples include acoustic monitoring, vibration monitoring, force measurements, strain measurements, etc.

Have not used vibration monitoring on a long-term basis. Has only been used for short durations to determine frequency and magnitude, etc.

Q9: What would you recommend that the cable suppliers incorporate into their systems to make cables more accessible and inspectable?

no answer

Q10: Do you believe that an up-to-date resource such as a national database of information on stay cable inspection methods, repairs, and testing would be a useful tool?

yes

Q11: What do you see as the single most important problem in stay cable maintenance?

Access for inspection and actual testing

Q12: Please comment on any other methods for inspections, testing, monitoring, and repair of stay cable (including conventional methods) that you have found beneficial and are not listed above.

no answer

Additional comments?

The five bridges identified are all pedestrian structures; three over water and two over roadways.

NCHRP SYNTHESIS TOPIC 35-07—INSPECTION AND MAINTENANCE OF BRIDGE STAY CABLE SYSTEMS

*Stoney Trail (Pedestrian)
Alberta/Calgary, Canada*

*Questionnaire Results
Survey performed in 2004*

Stoney Trail (Pedestrian)

State/Province: *Alberta/Calgary, Canada*

Agency: *City of Calgary*

Respondent: *Peter Wilson*

Span Length: *335 ft*

Year Built: *1998*

Q4-4: Type of main tension element (MTE)?

steel bar or threadbar

Q4-5: Coating/treatment on main tension element within free length of cable?

galvanized steel

Q4-6: Are the coatings/treatments on main tension element discontinued or removed within the anchorage zone?

no

Q4-7: Type of grout used?

grout not used

Q4-8: Are filler materials used in the anchorage zone?

no filler

Q4-9: Type of anchorage?

other, threaded couplers/nuts

Q4-10: Do cables go over “saddles” on the pylons?

no

Q4-11: Type of cable sheathing used?

no sheathing

Q4-12: Have rain–wind-induced cable vibrations been observed on this bridge?

not known

Q4-13: Have MTE corrosion problems been noted?

no

Q4-14: Do cables have neoprene rings near the top and bottom anchorages?

no

Q4-15: If there are neoprene rings on the cables; have there been any reports of movements of the rings out of their positions?

not applicable

Q4-16: Has moisture been found in any of the internal components of stay cables such as the bottom anchorage areas?

no

Q4-17: Has fatigue of MTE or other components of stay cables been observed?

no

Q4-18: Do the cables have viscous dampers installed at deck or tower levels?

no

Q4-19: Do the cables have cross cables installed between them?

yes, from the beginning

Q4-20: Do cables have other dampers (other than viscous or neoprene rings) to control vibrations?

no

Q4-21: Has cracking of the cable sheathing or sheathing connections been noted?

no

Q4-22: Has cracking or misalignment of the guide pipes been noted?

no

Q4-23: If there is protective tape wrapped around the cable sheathing; have there been reports of deterioration of the tape?

not known

Q4-24: Have any problems associated with neoprene boots been noted?

no

Q4-25: Types of non-destructive tests that any of the cables on this bridge have been subjected to?

not performed

Q4-26: Types of sensor-based, long-term monitoring performed on the cables?

not performed

Q4-27: Have the cables on this bridge (or any of their components) been repaired?

no

NCHRP SYNTHESIS TOPIC 35-07—INSPECTION AND MAINTENANCE OF BRIDGE STAY CABLE SYSTEMS

Stoney Trail (Pedestrian)
Alberta/Calgary, Canada

Questionnaire Results
Survey performed in 2004

Q4-28: Has the sheathing been partially removed on any of the cables to examine condition of grout (if applicable) and/or the MTE?

no

Q4-29: Can the strands or cables be replaced if needed?

yes

Q4-30: Do you have an inspection and maintenance manual for this bridge?

no

Q5: Based on your experience and in general, do you believe that the current inspection, testing, monitoring, and repair methods available to you for stay cables are effective and adequate?

yes

Q6: Please comment on the effectiveness of any non-destructive test methods for inspections of stay cables that you may be familiar with. These methods include (but are not limited to) ultrasonic testing, magnetic inspections, laser-based force measurements, X-ray imaging, etc. If possible, please comment on issues such as practicality, cost, duration, impact on traffic, and any other factors that you consider important.

no answer

Q7: Please comment on the effectiveness of any cable vibration control measures that you may be familiar with. Examples include

installation of cross cables, viscous dampers, neoprene rings, etc.

The installation of cross cables has greatly reduced the cable vibration.

Q8: Please comment on the effectiveness of any sensor-based, long-term monitoring systems for stay cables that you may be familiar with. Examples include acoustic monitoring, vibration monitoring, force measurements, strain measurements, etc.

Have not used vibration monitoring on a long-term basis. Has only been used for short durations to determine frequency and magnitude, etc.

Q9: What would you recommend that the cable suppliers incorporate into their systems to make cables more accessible and inspectable?

no answer

Q10: Do you believe that an up-to-date resource such as a national database of information on stay cable inspection methods, repairs, and testing would be a useful tool?

yes

Q11: What do you see as the single most important problem in stay cable maintenance?

Access for inspection and actual testing

Q12: Please comment on any other methods for inspections, testing, monitoring, and repair of stay cable (including conventional methods) that you have found beneficial and are not listed above.

no answer

Additional comments?

The five bridges identified are all pedestrian structures; three over water and two over roadways.

NCHRP SYNTHESIS TOPIC 35-07—INSPECTION AND MAINTENANCE OF BRIDGE STAY CABLE SYSTEMS

Alex Fraser Bridge
British Columbia

Questionnaire Results
Survey performed in 2004

Alex Fraser Bridge

State/Province: *British Columbia*
Agency: *Ministry of Transportation*
Respondent: *Kevin Baskin*
Span Length: *1,526 ft*
Year Built: *1986*

Q4-4: Type of main tension element (MTE)?
other—7.1 mm diameter galvanized wire to ASTM A586; ultimate strength = 1520 MPa; long lay strand assemblies with 109 to 283 wires per assembly.

Q4-5: Coating/treatment on main tension element within free length of cable?

greased-and-sheathed—galvanized; galvanized wire cable jacketed in polyethylene tube and filled with petroleum wax blocking compound.

Q4-6: Are the coatings/treatments on main tension element discontinued or removed within the anchorage zone?

yes—zinc-filled cast steel socket at end, grease discontinued in anchorages

Q4-7: Type of grout used?

grout not used

Q4-8: Are filler materials used in the anchorage zone?

yes, other—cast steel socket anchorage is filled with zinc.

Q4-9: Type of anchorage?

zinc-filled cast steel socket

Q4-10: Do cables go over “saddles” on the pylons?

no

Q4-11: Type of cable sheathing used?

UV-resistant HDPE

Q4-12: Have rain–wind-induced cable vibrations been observed on this bridge?

yes

Q4-13: Have MTE corrosion problems been noted?

no

Q4-14: Do cables have neoprene rings near the top and bottom anchorages?

yes

Q4-15: If there are neoprene rings on the cables; have there been any reports of movements of the rings out of their positions?

yes—due to other reasons

Q4-16: Has moisture been found in any of the internal components of stay cables such as the bottom anchorage areas?

no

Q4-17: Has fatigue of MTE or other components of stay cables been observed?

no

Q4-18: Do the cables have viscous dampers installed at deck or tower levels?

no

Q4-19: Do the cables have cross cables installed between them?

no

Q4-20: Do cables have other dampers (other than viscous or neoprene rings) to control vibrations?

no

Q4-21: Has cracking of the cable sheathing or sheathing connections been noted?

no

Q4-22: Has cracking or misalignment of the guide pipes been noted?

not applicable

Q4-23: If there is protective tape wrapped around the cable sheathing; have there been reports of deterioration of the tape?

not applicable—repairs used protective tape, no deterioration observed

Q4-24: Have any problems associated with neoprene boots been noted?

yes, shifting and splitting

Q4-25: Types of non-destructive tests that any of the cables on this bridge have been subjected to?

not performed

NCHRP SYNTHESIS TOPIC 35-07—INSPECTION AND MAINTENANCE OF BRIDGE STAY CABLE SYSTEMS

Alex Fraser Bridge
British Columbia

Questionnaire Results
Survey performed in 2004

Q4-26: Types of sensor-based, long-term monitoring performed on the cables?

Acoustic wire break detection—performed short term, now discontinued.

Q4-27: Have the cables on this bridge (or any of their components) been repaired?

yes—boots replaced or repaired, sheaths repaired.

Q4-28: Has the sheathing been partially removed on any of the cables to examine condition of grout (if applicable) and/or the MTE?

no

Q4-29: Can the strands or cables be replaced if needed?

yes

Q4-30: Do you have an inspection and maintenance manual for this bridge?

yes

Q5: Based on your experience and in general, do you believe that the current inspection, testing, monitoring, and repair methods available to you for stay cables are effective and adequate?

yes

Q6: Please comment on the effectiveness of any non-destructive test methods for inspections of stay cables that you may be familiar with. These methods include (but are not limited to) ultrasonic testing, magnetic inspections, laser-based force measurements,

X-ray imaging, etc. If possible, please comment on issues such as practicality, cost, duration, impact on traffic, and any other factors that you consider important.

not used

Q7: Please comment on the effectiveness of any cable vibration control measures that you may be familiar with. Examples include installation of cross cables, viscous dampers, neoprene rings, etc.

Neoprene ring dampers alone do not prevent cable vibration.

Q8: Please comment on the effectiveness of any sensor-based, long-term monitoring systems for stay cables that you may be familiar with. Examples include acoustic monitoring, vibration monitoring, force measurements, strain measurements, etc.

Acoustic monitoring may be cost-effective for older structures. For new structures, cost of monitoring outweighs benefits, and may be compromised by other noise (rehab, banging etc.) on the structure.

Q9: What would you recommend that the cable suppliers incorporate into their systems to make cables more accessible and inspectable?

Our cables are reasonably accessible, inspectable. Possibly a closeable drain at the lower end of the cable to allow visual inspection, sample collection, testing for corrosion product of any water in the cable sheaths.

Q10: Do you believe that an up-to-date resource such as a national database of information on stay cable inspection methods, repairs, and testing would be a useful tool?

yes

Q11: What do you see as the single most important problem in stay cable maintenance?

detecting corrosion in cables, maintenance of sheaths and boots

Q12: Please comment on any other methods for inspections, testing, monitoring, and repair of stay cable (including conventional methods) that you have found beneficial and are not listed above.

no comment.

Additional comments?

Have had leakage of wax blocking compound at bottom anchorages during hot weather.

Esplanade Riel
 Manitoba/Winnipeg, Canada

Questionnaire Results
 Survey performed in 2004

Esplanade Riel

State/Province: *Manitoba/Winnipeg, Canada*
 Agency: *City of Winnipeg Public Works Department*
 Respondent: *Brad Neirinck*
 Span Length: *348 ft*
 Year Built: *2003*

Q4-4: Type of main tension element (MTE)?

seven-wire steel strand

Q4-5: Coating/treatment on main tension element within free length of cable?

galvanized steel, further coated with high-density polyethylene

Q4-6: Are the coatings/treatments on main tension element discontinued or removed within the anchorage zone?

yes, HDPE coating is removed

Q4-7: Type of grout used?

grout not used

Q4-8: Are filler materials used in the anchorage zone?

yes, other—epoxy filler

Q4-9: Type of anchorage?

conical socket with wedges

Q4-10: Do cables go over “saddles” on the pylons?

no

Q4-11: Type of cable sheathing used?

UV-resistant HDPE with spiral on surface

Q4-12: Have rain–wind-induced cable vibrations been observed on this bridge?

no

Q4-13: Have MTE corrosion problems been noted?

no

Q4-14: Do cables have neoprene rings near the top and bottom anchorages?

yes, these provide damping

Q4-15: If there are neoprene rings on the cables; have there been any reports of movements of the rings out of their positions?

no, not known

Q4-16: Has moisture been found in any of the internal components of stay cables such as the bottom anchorage areas?

no

Q4-17: Has fatigue of MTE or other components of stay cables been observed?

no

Q4-18: Do the cables have viscous dampers installed at deck or tower levels?

no—damping via neoprene rings

Q4-19: Do the cables have cross cables installed between them?

no

Q4-20: Do cables have other dampers (other than viscous or neoprene rings) to control vibrations?

no

Q4-21: Has cracking of the cable sheathing or sheathing connections been noted?

no

Q4-22: Has cracking or misalignment of the guide pipes been noted?

no

Q4-23: If there is protective tape wrapped around the cable sheathing; have there been reports of deterioration of the tape?

not applicable

Q4-24: Have any problems associated with neoprene boots been noted?

no

Q4-25: Types of non-destructive tests that any of the cables on this bridge have been subjected to?

Not performed. Vibration-based force measurements on selected MTE will be performed and continuously monitored using a permanent SHM system.

Q4-26: Types of sensor-based, long-term monitoring performed on the cables?

vibration monitoring

NCHRP SYNTHESIS TOPIC 35-07—INSPECTION AND MAINTENANCE OF BRIDGE STAY CABLE SYSTEMS

Esplanade Riel
Manitoba/Winnipeg, Canada

Questionnaire Results
Survey performed in 2004

Q4-27: Have the cables on this bridge (or any of their components) been repaired?

yes—extensions to permit additional thermal contraction capability of the HDPE sheathing installed. Warranty covered this.

Q4-28: Has the sheathing been partially removed on any of the cables to examine condition of grout (if applicable) and/or the MTE?

no

Q4-29: Can the strands or cables be replaced if needed?

yes

Q4-30: Do you have an inspection and maintenance manual for this bridge?

no—since this is a new bridge this should be an upcoming deliverable from our consultant.

Q5: Based on your experience and in general, do you believe that the current inspection, testing, monitoring, and repair methods available to you for stay cables are effective and adequate?

Not known. We require training and awareness in the near future to properly maintain the one new bridge we have.

Q6: Please comment on the effectiveness of any non-destructive test methods for inspections of stay cables that you may be familiar with. These methods include (but are not limited to) ultrasonic testing, magnetic inspections, laser-based force measurements, X-ray imaging, etc. If possible, please

comment on issues such as practicality, cost, duration, impact on traffic, and any other factors that you consider important.

We do not yet have enough experience to respond to this question at this time. We are aware of all the techniques you mention above. Force measurements on selected MTE will be performed as part of the SHM system with the use of uniaxial accelerometers to determine frequency of the cable and relate back to force.

Q7: Please comment on the effectiveness of any cable vibration control measures that you may be familiar with. Examples include installation of cross cables, viscous dampers, neoprene rings, etc.

We have yet to pass judgment on the effectiveness of the control measures. We specified the requirement for damping at the anchorages. The supplier choose to do this via neoprene rings.

Q8: Please comment on the effectiveness of any sensor-based, long-term monitoring systems for stay cables that you may be familiar with. Examples include acoustic monitoring, vibration monitoring, force measurements, strain measurements, etc.

Not enough experience to comment at this time.

Q9: What would you recommend that the cable suppliers incorporate into their systems to make cables more accessible and inspectable?

Different corrosion protection system at the anchorages that permits easier visual inspection. Removable sections of the HDPE and Vandal Tubes would make it easier to inspect strands near the anchorages.

Q10: Do you believe that an up-to-date resource such as a national database of information on stay cable inspection methods, repairs, and testing would be a useful tool?

yes

Q11: What do you see as the single most important problem in stay cable maintenance?

corrosion at the anchorages

Q12: Please comment on any other methods for inspections, testing, monitoring, and repair of stay cable (including conventional methods) that you have found beneficial and are not listed above.

no answer

Additional comments?

NCHRP SYNTHESIS TOPIC 35-07—INSPECTION AND MAINTENANCE OF BRIDGE STAY CABLE SYSTEMS

*Hawkshaw
New Brunswick, Canada*

*Questionnaire Results
Survey performed in 2004*

Hawkshaw

State/Province: *New Brunswick, Canada*

Agency: *New Brunswick Department
of Transportation*

Respondent: *Ronald H. Joyce*

Span Length: *713.32 ft*

Year Built: *1967*

Q4-4: Type of main tension element (MTE)?

*steel wire—2-3/8-in. diameter galvanized steel
cables. Located near Nackawic NB over the
Saint John River between Rte 2 and Rte 105*

Q4-5: Coating/treatment on main tension
element within free length of cable?

*galvanized steel—cables are wrapped 5 ft
above deck with galvanized wire; also in this
area they are coated with Denso Paste and
tape*

Q4-6: Are the coatings/treatments on main
tension element discontinued or removed
within the anchorage zone?

no

Q4-7: Type of grout used?

grout not used

Q4-8: Are filler materials used in the
anchorage zone?

no filler

Q4-9: Type of anchorage?

other—2-3/8-in. forged open strand socket

Q4-10: Do cables go over “saddles” on the
pylons?

no—pin connections at top of pylon

Q4-11: Type of cable sheathing used?

no sheathing

Q4-12: Have rain–wind-induced cable
vibrations been observed on this bridge?

yes

Q4-13: Have MTE corrosion problems been
noted?

no

Q4-14: Do cables have neoprene rings near the
top and bottom anchorages?

no

Q4-15: If there are neoprene rings on the
cables; have there been any reports of
movements of the rings out of their positions?

not applicable

Q4-16: Has moisture been found in any of the
internal components of stay cables such as the
bottom anchorage areas?

not tested

Q4-17: Has fatigue of MTE or other
components of stay cables been observed?

no

Q4-18: Do the cables have viscous dampers
installed at deck or tower levels?

*yes—retrofitted to correct vibrations; wood
clamps placed at 1/3 points of the six cables*

Q4-19: Do the cables have cross cables
installed between them?

no

Q4-20: Do cables have other dampers (other
than viscous or neoprene rings) to control
vibrations?

yes—other dampers, wood clamps

Q4-21: Has cracking of the cable sheathing or
sheathing connections been noted?

not applicable

Q4-22: Has cracking or misalignment of the
guide pipes been noted?

not applicable

Q4-23: If there is protective tape wrapped
around the cable sheathing; have there been
reports of deterioration of the tape?

no

Q4-24: Have any problems associated with
neoprene boots been noted?

no answer

Q4-25: Types of non-destructive tests that any
of the cables on this bridge have been subjected
to?

not performed

NCHRP SYNTHESIS TOPIC 35-07—INSPECTION AND MAINTENANCE OF BRIDGE STAY CABLE SYSTEMS

Hawkshaw
New Brunswick, Canada

Questionnaire Results
Survey performed in 2004

Q4-26: Types of sensor-based, long-term monitoring performed on the cables?

not performed

Q4-27: Have the cables on this bridge (or any of their components) been repaired?

no

Q4-28: Has the sheathing been partially removed on any of the cables to examine condition of grout (if applicable) and/or the MTE?

not applicable

Q4-29: Can the strands or cables be replaced if needed?

not known

Q4-30: Do you have an inspection and maintenance manual for this bridge?

no

Q5: Based on your experience and in general, do you believe that the current inspection, testing, monitoring, and repair methods available to you for stay cables are effective and adequate?

yes

Q6: Please comment on the effectiveness of any non-destructive test methods for inspections of stay cables that you may be familiar with. These methods include (but are not limited to) ultrasonic testing, magnetic inspections, laser-based force measurements, X-ray imaging, etc. If possible, please comment on issues such as practicality, cost,

duration, impact on traffic, and any other factors that you consider important.

None of this testing done on any of the three structures; probably there would be a significant cost to do these tests.

Q7: Please comment on the effectiveness of any cable vibration control measures that you may be familiar with. Examples include installation of cross cables, viscous dampers, neoprene rings, etc.

See comments for Question 4-12.

Q8: Please comment on the effectiveness of any sensor-based, long-term monitoring systems for stay cables that you may be familiar with. Examples include acoustic monitoring, vibration monitoring, force measurements, strain measurements, etc.

Monitoring of deflection of bridge by student at Nackawic.

Q9: What would you recommend that the cable suppliers incorporate into their systems to make cables more accessible and inspectable?

no answer

Q10: Do you believe that an up-to-date resource such as a national database of information on stay cable inspection methods, repairs, and testing would be a useful tool?

yes

Q11: What do you see as the single most important problem in stay cable maintenance?

Migration of water into cable strands.

Q12: Please comment on any other methods for inspections, testing, monitoring, and repair of stay cable (including conventional methods) that you have found beneficial and are not listed above.

no answer

Additional comments?

NCHRP SYNTHESIS TOPIC 35-07—INSPECTION AND MAINTENANCE OF BRIDGE STAY CABLE SYSTEMS

Longs Creek #1
New Brunswick, Canada

Questionnaire Results
Survey performed in 2004

Longs Creek #1

State/Province: **New Brunswick, Canada**
 Agency: **New Brunswick Department of Transportation**
 Respondent: **Ronald H. Joyce**
 Span Length: **713.32 ft**
 Year Built: **1966**

Q4-4: Type of main tension element (MTE)?

No answer—located on Rte 102 west of Fredricton, NB

Q4-5: Coating/treatment on main tension element within free length of cable?

galvanized steel

Q4-6: Are the coatings/treatments on main tension element discontinued or removed within the anchorage zone?

no

Q4-7: Type of grout used?

grout not used

Q4-8: Are filler materials used in the anchorage zone?

no filler

Q4-9: Type of anchorage?

other

Q4-10: Do cables go over “saddles” on the pylons?

no

Q4-11: Type of cable sheathing used?

no sheathing

Q4-12: Have rain–wind-induced cable vibrations been observed on this bridge?

yes

Q4-13: Have MTE corrosion problems been noted?

no

Q4-14: Do cables have neoprene rings near the top and bottom anchorages?

no

Q4-15: If there are neoprene rings on the cables; have there been any reports of movements of the rings out of their positions?

not applicable

Q4-16: Has moisture been found in any of the internal components of stay cables such as the bottom anchorage areas?

not tested

Q4-17: Has fatigue of MTE or other components of stay cables been observed?

no

Q4-18: Do the cables have viscous dampers installed at deck or tower levels?

yes, retrofitted to correct vibrations

Q4-19: Do the cables have cross cables installed between them?

no

Q4-20: Do cables have other dampers (other than viscous or neoprene rings) to control vibrations?

yes, other dampers

Q4-21: Has cracking of the cable sheathing or sheathing connections been noted?

not applicable

Q4-22: Has cracking or misalignment of the guide pipes been noted?

not applicable

Q4-23: If there is protective tape wrapped around the cable sheathing; have there been reports of deterioration of the tape?

yes, minor damage

Q4-24: Have any problems associated with neoprene boots been noted?

Q4-25: Types of non-destructive tests that any of the cables on this bridge have been subjected to?

not performed

Q4-26: Types of sensor-based, long-term monitoring performed on the cables?

not performed

Q4-27: Have the cables on this bridge (or any of their components) been repaired?

no

NCHRP SYNTHESIS TOPIC 35-07—INSPECTION AND MAINTENANCE OF BRIDGE STAY CABLE SYSTEMS

Longs Creek #1
New Brunswick, Canada

Questionnaire Results
Survey performed in 2004

Q4-28: Has the sheathing been partially removed on any of the cables to examine condition of grout (if applicable) and/or the MTE?

not applicable

Q4-29: Can the strands or cables be replaced if needed?

not known

Q4-30: Do you have an inspection and maintenance manual for this bridge?

no

Q5: Based on your experience and in general, do you believe that the current inspection, testing, monitoring, and repair methods available to you for stay cables are effective and adequate?

yes

Q6: Please comment on the effectiveness of any non-destructive test methods for inspections of stay cables that you may be familiar with. These methods include (but are not limited to) ultrasonic testing, magnetic inspections, laser-based force measurements, X-ray imaging, etc. If possible, please comment on issues such as practicality, cost, duration, impact on traffic, and any other factors that you consider important.

None of this testing done on any of the three structures; probably there would be a significant cost to do these tests.

Q7: Please comment on the effectiveness of any cable vibration control measures that you

may be familiar with. Examples include installation of cross cables, viscous dampers, neoprene rings, etc.

See comments for Question 4-12.

Q8: Please comment on the effectiveness of any sensor-based, long-term monitoring systems for stay cables that you may be familiar with. Examples include acoustic monitoring, vibration monitoring, force measurements, strain measurements, etc.

Monitoring of deflection of bridge by student at Nackawic.

Q9: What would you recommend that the cable suppliers incorporate into their systems to make cables more accessible and inspectable?

no answer

Q10: Do you believe that an up-to-date resource such as a national database of information on stay cable inspection methods, repairs, and testing would be a useful tool?

yes

Q11: What do you see as the single most important problem in stay cable maintenance?

Migration of water into cable strands.

Q12: Please comment on any other methods for inspections, testing, monitoring, and repair of stay cable (including conventional methods) that you have found beneficial and are not listed above.

no answer

Additional comments?

Paper to be given in Japan I believe in 2004 by an engineer who worked for the National Research Council on the deflections of the Longs Creek Bridge caused by wind and the methods used to greatly reduce this problem.

*Nackawic River
New Brunswick, Canada*

*Questionnaire Results
Survey performed in 2004*

Nackawic River

State/Province: *New Brunswick, Canada*

Agency: *New Brunswick Department
of Transportation*

Respondent: *Ronald H. Joyce*

Span Length: *216.01 ft*

Year Built: *1967*

Q4-4: Type of main tension element (MTE)?

Located on Rte. 105 in the town of Nackawic

Q4-5: Coating/treatment on main tension element within free length of cable?

galvanized steel

Q4-6: Are the coatings/treatments on main tension element discontinued or removed within the anchorage zone?

no

Q4-7: Type of grout used?

grout not used

Q4-8: Are filler materials used in the anchorage zone?

no filler

Q4-9: Type of anchorage?

other

Q4-10: Do cables go over “saddles” on the pylons?

no

Q4-11: Type of cable sheathing used?

no sheathing

Q4-12: Have rain–wind-induced cable vibrations been observed on this bridge?

yes

Q4-13: Have MTE corrosion problems been noted?

no

Q4-14: Do cables have neoprene rings near the top and bottom anchorages?

no

Q4-15: If there are neoprene rings on the cables; have there been any reports of movements of the rings out of their positions?

not applicable

Q4-16: Has moisture been found in any of the internal components of stay cables such as the bottom anchorage areas?

not tested

Q4-17: Has fatigue of MTE or other components of stay cables been observed?

no

Q4-18: Do the cables have viscous dampers installed at deck or tower levels?

yes, retrofitted to correct vibrations

Q4-19: Do the cables have cross cables installed between them?

no

Q4-20: Do cables have other dampers (other than viscous or neoprene rings) to control vibrations?

yes, other dampers

Q4-21: Has cracking of the cable sheathing or sheathing connections been noted?

not applicable

Q4-22: Has cracking or misalignment of the guide pipes been noted?

not applicable

Q4-23: If there is protective tape wrapped around the cable sheathing; have there been reports of deterioration of the tape?

no

Q4-24: Have any problems associated with neoprene boots been noted?

Q4-25: Types of non-destructive tests that any of the cables on this bridge have been subjected to?

not performed

Q4-26: Types of sensor-based, long-term monitoring performed on the cables?

not performed

Q4-27: Have the cables on this bridge (or any of their components) been repaired?

no

Q4-28: Has the sheathing been partially removed on any of the cables to examine

NCHRP SYNTHESIS TOPIC 35-07—INSPECTION AND MAINTENANCE OF BRIDGE STAY CABLE SYSTEMS

Nackawic River
New Brunswick, Canada

Questionnaire Results
Survey performed in 2004

condition of grout (if applicable) and/or the MTE?

not applicable

Q4-29: Can the strands or cables be replaced if needed?

not known

Q4-30: Do you have an inspection and maintenance manual for this bridge?

no

Q5: Based on your experience and in general, do you believe that the current inspection, testing, monitoring, and repair methods available to you for stay cables are effective and adequate?

yes

Q6: Please comment on the effectiveness of any non-destructive test methods for inspections of stay cables that you may be familiar with. These methods include (but are not limited to) ultrasonic testing, magnetic inspections, laser-based force measurements, X-ray imaging, etc. If possible, please comment on issues such as practicality, cost, duration, impact on traffic, and any other factors that you consider important.

None of this testing was done on any of the three structures; probably there would be a significant cost to do these tests.

Q7: Please comment on the effectiveness of any cable vibration control measures that you may be familiar with. Examples include

installation of cross cables, viscous dampers, neoprene rings, etc.

See comments for Question 4-12.

Q8: Please comment on the effectiveness of any sensor-based, long-term monitoring systems for stay cables that you may be familiar with. Examples include acoustic monitoring, vibration monitoring, force measurements, strain measurements, etc.

Monitoring of deflection of bridge by student at Nackawic.

Q9: What would you recommend that the cable suppliers incorporate into their systems to make cables more accessible and inspectable?

no answer

Q10: Do you believe that an up-to-date resource such as a national database of information on stay cable inspection methods, repairs, and testing would be a useful tool?

yes

Q11: What do you see as the single most important problem in stay cable maintenance?

Migration of water into cable strands.

Q12: Please comment on any other methods for inspections, testing, monitoring, and repair of stay cable (including conventional methods) that you have found beneficial and are not listed above.

no answer

Additional comments?

NCHRP SYNTHESIS TOPIC 35-07—INSPECTION AND MAINTENANCE OF BRIDGE STAY CABLE SYSTEMS

*Galipeault
Quebec, Canada*

*Questionnaire Results
Survey performed in 2004*

Galipeault

State/Province: *Quebec, Canada*
 Agency: *Ministry of Transportation*
 Respondent: *Martin, Talbot*
 Span Length: *308 ft*
 Year Built: *1963*

Q4-4: Type of main tension element (MTE)?
*steel wire—2 9/16-in. diameter bridge strand
 cable type = 1 x 140 wires*

Q4-5: Coating/treatment on main tension
 element within free length of cable?
galvanized steel

Q4-6: Are the coatings/treatments on main
 tension element discontinued or removed
 within the anchorage zone?
no

Q4-7: Type of grout used?
grout not used

Q4-8: Are filler materials used in the
 anchorage zone?
no filler

Q4-9: Type of anchorage?
other—closed and open socket

Q4-10: Do cables go over “saddles” on the
 pylons?
no

Q4-11: Type of cable sheathing used?
no sheathing

Q4-12: Have rain–wind-induced cable
 vibrations been observed on this bridge?
no

Q4-13: Have MTE corrosion problems been
 noted?
no

Q4-14: Do cables have neoprene rings near the
 top and bottom anchorages?
no

Q4-15: If there are neoprene rings on the
 cables; have there been any reports of
 movements of the rings out of their positions?
not applicable

Q4-16: Has moisture been found in any of the
 internal components of stay cables such as the
 bottom anchorage areas?
no

Q4-17: Has fatigue of MTE or other
 components of stay cables been observed?
no

Q4-18: Do the cables have viscous dampers
 installed at deck or tower levels?
no

Q4-19: Do the cables have cross cables
 installed between them?
no

Q4-20: Do cables have other dampers (other
 than viscous or neoprene rings) to control
 vibrations?
no

Q4-21: Has cracking of the cable sheathing or
 sheathing connections been noted?
not applicable

Q4-22: Has cracking or misalignment of the
 guide pipes been noted?
not applicable

Q4-23: If there is protective tape wrapped
 around the cable sheathing; have there been
 reports of deterioration of the tape?
not applicable

Q4-24: Have any problems associated with
 neoprene boots been noted?
no

Q4-25: Types of non-destructive tests that any
 of the cables on this bridge have been subjected
 to?
other—laser-based force measurements

Q4-26: Types of sensor-based, long-term
 monitoring performed on the cables?
not performed

Q4-27: Have the cables on this bridge (or any
 of their components) been repaired?
no

NCHRP SYNTHESIS TOPIC 35-07—INSPECTION AND MAINTENANCE OF BRIDGE STAY CABLE SYSTEMS

**Galipeault
Quebec, Canada**

**Questionnaire Results
Survey performed in 2004**

Q4-28: Has the sheathing been partially removed on any of the cables to examine condition of grout (if applicable) and/or the MTE?

not applicable

Q4-29: Can the strands or cables be replaced if needed?

yes

Q4-30: Do you have an inspection and maintenance manual for this bridge?

no

Q5: Based on your experience and in general, do you believe that the current inspection, testing, monitoring, and repair methods available to you for stay cables are effective and adequate?

yes

Q6: Please comment on the effectiveness of any non-destructive test methods for inspections of stay cables that you may be familiar with. These methods include (but are not limited to) ultrasonic testing, magnetic inspections, laser-based force measurements, X-ray imaging, etc. If possible, please comment on issues such as practicality, cost, duration, impact on traffic, and any other factors that you consider important.

We have performed laser-based force on Galipeault bridge.

Q7: Please comment on the effectiveness of any cable vibration control measures that you may be familiar with. Examples include

installation of cross cables, viscous dampers, neoprene rings, etc.

Q8: Please comment on the effectiveness of any sensor-based, long-term monitoring systems for stay cables that you may be familiar with. Examples include acoustic monitoring, vibration monitoring, force measurements, strain measurements, etc.

No long-term monitoring on our stay cable bridges at the present time.

Q9: What would you recommend that the cable suppliers incorporate into their systems to make cables more accessible and inspectable?

no answer

Q10: Do you believe that an up-to-date resource such as a national database of information on stay cable inspection methods, repairs, and testing would be a useful tool?

yes

Q11: What do you see as the single most important problem in stay cable maintenance?

fatigue

Q12: Please comment on any other methods for inspections, testing, monitoring, and repair of stay cable (including conventional methods) that you have found beneficial and are not listed above.

no answer

Additional comments?

We have had a serious problem on Galipeault bridge no. 1—failure of an anchorage plate at

***one abutment (corrosion and fatigue failure).
Emergency repairs were performed.***

Papineau
Quebec, Canada

Questionnaire Results
Survey performed in 2004

Papineau

State/Province: *Quebec, Canada*

Agency: *Ministry of Transportation*

Respondent: *Martin, Talbot*

Span Length: *790 ft*

Year Built: *1969*

Q4-4: Type of main tension element (MTE)?

steel wire—strands 2 5/16-in. and 1 5/8-in. diameter. Strand fabricated from 0.192-in. diameter galvanized wire

Q4-5: Coating/treatment on main tension element within free length of cable?

galvanized steel—and polyethylene coating

Q4-6: Are the coatings/treatments on main tension element discontinued or removed within the anchorage zone?

no

Q4-7: Type of grout used?

not applicable

Q4-8: Are filler materials used in the anchorage zone?

no filler

Q4-9: Type of anchorage?

other—cylindrical socket into which a threaded rod is screwed

Q4-10: Do cables go over “saddles” on the pylons?

yes

Q4-11: Type of cable sheathing used?

other—polyethylene coating

Q4-12: Have rain–wind-induced cable vibrations been observed on this bridge?

no

Q4-13: Have MTE corrosion problems been noted?

yes, corrosion on threaded rod

Q4-14: Do cables have neoprene rings near the top and bottom anchorages?

yes

Q4-15: If there are neoprene rings on the cables; have there been any reports of movements of the rings out of their positions?

no, not known

Q4-16: Has moisture been found in any of the internal components of stay cables such as the bottom anchorage areas?

no

Q4-17: Has fatigue of MTE or other components of stay cables been observed?

no

Q4-18: Do the cables have viscous dampers installed at deck or tower levels?

no

Q4-19: Do the cables have cross cables installed between them?

no

Q4-20: Do cables have other dampers (other than viscous or neoprene rings) to control vibrations?

no

Q4-21: Has cracking of the cable sheathing or sheathing connections been noted?

no

Q4-22: Has cracking or misalignment of the guide pipes been noted?

not applicable

Q4-23: If there is protective tape wrapped around the cable sheathing; have there been reports of deterioration of the tape?

not applicable

Q4-24: Have any problems associated with neoprene boots been noted?

no

Q4-25: Types of non-destructive tests that any of the cables on this bridge have been subjected to?

not performed

Q4-26: Types of sensor-based, long-term monitoring performed on the cables?

not performed

NCHRP SYNTHESIS TOPIC 35-07—INSPECTION AND MAINTENANCE OF BRIDGE STAY CABLE SYSTEMS

Papineau
Quebec, Canada

Questionnaire Results
Survey performed in 2004

Q4-27: Have the cables on this bridge (or any of their components) been repaired?

no

Q4-28: Has the sheathing been partially removed on any of the cables to examine condition of grout (if applicable) and/or the MTE?

no

Q4-29: Can the strands or cables be replaced if needed?

no

Q4-30: Do you have an inspection and maintenance manual for this bridge?

no

Q5: Based on your experience and in general, do you believe that the current inspection, testing, monitoring, and repair methods available to you for stay cables are effective and adequate?

yes

Q6: Please comment on the effectiveness of any non-destructive test methods for inspections of stay cables that you may be familiar with. These methods include (but are not limited to) ultrasonic testing, magnetic inspections, laser-based force measurements, X-ray imaging, etc. If possible, please comment on issues such as practicality, cost, duration, impact on traffic, and any other factors that you consider important.

We have performed laser-based force on Galipeault bridge.

Q7: Please comment on the effectiveness of any cable vibration control measures that you may be familiar with. Examples include installation of cross cables, viscous dampers, neoprene rings, etc.

Q8: Please comment on the effectiveness of any sensor-based, long-term monitoring systems for stay cables that you may be familiar with. Examples include acoustic monitoring, vibration monitoring, force measurements, strain measurements, etc.

No long-term monitoring on our stay cable bridges at the present time.

Q9: What would you recommend that the cable suppliers incorporate into their systems to make cables more accessible and inspectable?

no answer

Q10: Do you believe that an up-to-date resource such as a national database of information on stay cable inspection methods, repairs, and testing would be a useful tool?

yes

Q11: What do you see as the single most important problem in stay cable maintenance?

fatigue

Q12: Please comment on any other methods for inspections, testing, monitoring, and repair of stay cable (including conventional methods) that you have found beneficial and are not listed above.

no answer

Additional comments?

We have had a serious problem on Galipeault bridge no. 1—failure of an anchorage plate at one abutment (corrosion and fatigue failure). Emergency repairs were performed.

Price
Quebec, Canada

Questionnaire Results
Survey performed in 2004

Price

State/Province: *Quebec, Canada*

Agency: *Ministry of Transportation*

Respondent: *Martin, Talbot*

Span Length: *450 ft*

Year Built: *1972*

Q4-4: Type of main tension element (MTE)?

steel wire—galvanized bridge strands. 2.5-in. and 2.56-in. diameter.

Q4-5: Coating/treatment on main tension element within free length of cable?

galvanized steel—and polyethylene coating 0.209 in. thickness

Q4-6: Are the coatings/treatments on main tension element discontinued or removed within the anchorage zone?

no

Q4-7: Type of grout used?

grout not used

Q4-8: Are filler materials used in the anchorage zone?

no filler

Q4-9: Type of anchorage?

other—cylindrical socket into which a threaded rod is screwed

Q4-10: Do cables go over “saddles” on the pylons?

no

Q4-11: Type of cable sheathing used?

other—polyethylene coating

Q4-12: Have rain–wind-induced cable vibrations been observed on this bridge?

no, strong wind vibration

Q4-13: Have MTE corrosion problems been noted?

no

Q4-14: Do cables have neoprene rings near the top and bottom anchorages?

yes

Q4-15: If there are neoprene rings on the cables; have there been any reports of movements of the rings out of their positions?

yes—due to shearing off of retainers

Q4-16: Has moisture been found in any of the internal components of stay cables such as the bottom anchorage areas?

no

Q4-17: Has fatigue of MTE or other components of stay cables been observed?

yes, see Question 4-27

Q4-18: Do the cables have viscous dampers installed at deck or tower levels?

no

Q4-19: Do the cables have cross cables installed between them?

no

Q4-20: Do cables have other dampers (other than viscous or neoprene rings) to control vibrations?

no

Q4-21: Has cracking of the cable sheathing or sheathing connections been noted?

no

Q4-22: Has cracking or misalignment of the guide pipes been noted?

not applicable

Q4-23: If there is protective tape wrapped around the cable sheathing; have there been reports of deterioration of the tape?

not applicable

Q4-24: Have any problems associated with neoprene boots been noted?

no

Q4-25: Types of non-destructive tests that any of the cables on this bridge have been subjected to?

not performed

Q4-26: Types of sensor-based, long-term monitoring performed on the cables?

not performed

Q4-27: Have the cables on this bridge (or any of their components) been repaired?

Price
Quebec, Canada

Questionnaire Results
Survey performed in 2004

yes—broken anchor bolt. Failure of two 5-in. anchor bolts in the anchorage zone

Q4-28: Has the sheathing been partially removed on any of the cables to examine condition of grout (if applicable) and/or the MTE?

no

Q4-29: Can the strands or cables be replaced if needed?

yes

Q4-30: Do you have an inspection and maintenance manual for this bridge?

no

Q5: Based on your experience and in general, do you believe that the current inspection, testing, monitoring, and repair methods available to you for stay cables are effective and adequate?

Q6: Please comment on the effectiveness of any non-destructive test methods for inspections of stay cables that you may be familiar with. These methods include (but are not limited to) ultrasonic testing, magnetic inspections, laser-based force measurements, X-ray imaging, etc. If possible, please comment on issues such as practicality, cost, duration, impact on traffic, and any other factors that you consider important.

Q7: Please comment on the effectiveness of any cable vibration control measures that you may be familiar with. Examples include

installation of cross cables, viscous dampers, neoprene rings, etc.

Neoprene rings have reduced cable vibrations on the Price Bridge (no. 3).

Q8: Please comment on the effectiveness of any sensor-based, long-term monitoring systems for stay cables that you may be familiar with. Examples include acoustic monitoring, vibration monitoring, force measurements, strain measurements, etc.

Q9: What would you recommend that the cable suppliers incorporate into their systems to make cables more accessible and inspectable?

Q10: Do you believe that an up-to-date resource such as a national database of information on stay cable inspection methods, repairs, and testing would be a useful tool?

Q11: What do you see as the single most important problem in stay cable maintenance?

Q12: Please comment on any other methods for inspections, testing, monitoring, and repair of stay cable (including conventional methods) that you have found beneficial and are not listed above.

Additional comments?

We also had a failure of an anchorage plate on Price Bridge (no. 3) during the 1988 Saguenay earthquake (ML = 6.0). It was the first documented structural damage to a steel bridge caused by an earthquake in Canada.

NCHRP SYNTHESIS TOPIC 35-07—INSPECTION AND MAINTENANCE OF BRIDGE STAY CABLE SYSTEMS

Questionnaire Results
Survey performed in 2004

Freyssinet

State/Province: *Freyssinet*

Agency: *Freyssinet LLC*

Respondent: *Andrew Micklus*

Span Length: *ft*

Year Built:

Q4-4: Type of main tension element (MTE)?

Q4-5: Coating/treatment on main tension element within free length of cable?

Q4-6: Are the coatings/treatments on main tension element discontinued or removed within the anchorage zone?

Q4-7: Type of grout used?

Q4-8: Are filler materials used in the anchorage zone?

Q4-9: Type of anchorage?

Q4-10: Do cables go over “saddles” on the pylons?

Q4-11: Type of cable sheathing used?

Q4-12: Have rain–wind-induced cable vibrations been observed on this bridge?

Q4-13: Have MTE corrosion problems been noted?

Q4-14: Do cables have neoprene rings near the top and bottom anchorages?

Q4-15: If there are neoprene rings on the cables; have there been any reports of movements of the rings out of their positions?

Q4-16: Has moisture been found in any of the internal components of stay cables such as the bottom anchorage areas?

Q4-17: Has fatigue of MTE or other components of stay cables been observed?

Q4-18: Do the cables have viscous dampers installed at deck or tower levels?

Q4-19: Do the cables have cross cables installed between them?

Q4-20: Do cables have other dampers (other than viscous or neoprene rings) to control vibrations?

Q4-21: Has cracking of the cable sheathing or sheathing connections been noted?

Q4-22: Has cracking or misalignment of the guide pipes been noted?

Q4-23: If there is protective tape wrapped around the cable sheathing; have there been reports of deterioration of the tape?

Q4-24: Have any problems associated with neoprene boots been noted?

Q4-25: Types of non-destructive tests that any of the cables on this bridge have been subjected to?

Q4-26: Types of sensor-based, long-term monitoring performed on the cables?

Q4-27: Have the cables on this bridge (or any of their components) been repaired?

Q4-28: Has the sheathing been partially removed on any of the cables to examine

condition of grout (if applicable) and/or the MTE?

Q4-29: Can the strands or cables be replaced if needed?

Q4-30: Do you have an inspection and maintenance manual for this bridge?

Q5: Based on your experience and in general, do you believe that the current inspection, testing, monitoring, and repair methods available to you for stay cables are effective and adequate?

yes. Freyssinet has installed its stay system on three projects:

Bill Emerson Bridge over the Mississippi River at Cape Girardeau, Missouri

I-93 over the Charles River in Boston, Mass.

Cooper River Replacement Bridge in Charleston, S.C.

The Cape Girardeau Bridge was required to be grouted by the Owner and Engineer. Freyssinet proposed ungrouted stays but this was unacceptable for reasons unknown. The thought was the Owner and Engineer did not want to be the first in United States to allow ungrouted stays. The Charles River was designed to use grouted stays, but Freyssinet was able to convince the Owner and Engineer that ungrouted stays were superior, mainly due to the improved inspectability and replaceability but also to avoid the common problems associated with grouted cables (introduce moisture, increase local bending moments at the anchorages, more mass to

NCHRP SYNTHESIS TOPIC 35-07—INSPECTION AND MAINTENANCE OF BRIDGE STAY CABLE SYSTEMS

*Questionnaire Results
Survey performed in 2004*

Freyssinet

dampen potential damage to the HDPE stay pipe if high grouting pressures are used. Also during grouting everything gets warm (or very hot if grouted during the summer in warm or even moderate climates). When colder winter temperatures arrive, the pipes develop very high tensile stresses as the pipe tries to thermally contract but is restrained since the grout has a much lower thermal coefficient of expansion and contraction. The cables on Cooper River Bridge are state of the art ungrouted stays with capacity to add approximately 5% strand in the future and the stays are fitted with engineered vibration suppression devices. Internal hydraulic and external hydraulic damping devices are being installed and provisions provide for the possible addition of cable ties (damping ropes) in the future on selected longer stays that have been identified as having the potential to experience parametric excitation.

Q6: Please comment on the effectiveness of any non-destructive test methods for inspections of stay cables that you may be familiar with. These methods include (but are not limited to) ultrasonic testing, magnetic inspections, laser-based force measurements, X-ray imaging, etc. If possible, please comment on issues such as practicality, cost, duration, impact on traffic, and any other factors that you consider important.

With ungrouted stays, individual strands may be detensioned, inspected, retensioned, or removed and/or replaced. Load cells may be left in place to monitor strands individually. Acoustic monitoring systems can be installed to

detect wire breakage and determine the break locations very accurately

Q7: Please comment on the effectiveness of any cable vibration control measures that you may be familiar with. Examples include installation of cross cables, viscous dampers, neoprene rings, etc.

External helix placed on the surface of the stay pipes has been proven to eliminate rain-wind-induced cable vibrations. Freyssinet developed this on the Normandie Bridge in France. Freyssinet offered this on Cape Girardeau and Charles River Projects and both sites elected to add external helix via a change order due to the very real threat of serious rain-wind-induced vibrations and the high level of effectiveness offered by the external helix.

Q8: Please comment on the effectiveness of any sensor-based, long-term monitoring systems for stay cables that you may be familiar with. Examples include acoustic monitoring, vibration monitoring, force measurements, strain measurements, etc.

We believe acoustical monitoring is an effective method to record wire failures. Permanent load cells are good for monitoring loads, especially with unbonded monostrands when it can be established that the load is equal in all individual strands within reasonable tolerances such that by monitoring 1 strand, the load in cable is known.

Q9: What would you recommend that the cable suppliers incorporate into their systems to make cables more accessible and inspectable?

Ability to de-tension, inspect, and retension individual strands, Ability to de-tension remove, and replace individual strands. Ability to add strands to each cable or cable group (avg. 5%).

Q10: Do you believe that an up-to-date resource such as a national database of information on stay cable inspection methods, repairs, and testing would be a useful tool?

yes

Q11: What do you see as the single most important problem in stay cable maintenance?

Inspectability in the anchorage area

Q12: Please comment on any other methods for inspections, testing, monitoring, and repair of stay cable (including conventional methods) that you have found beneficial and are not listed above.

no answer

Additional comments?

NCHRP SYNTHESIS TOPIC 35-07—INSPECTION AND MAINTENANCE OF BRIDGE STAY CABLE SYSTEMS

Questions:

Q4.4 Type of main tension element (MTE)?

Q4.5 Coating/treatment on main tension element within free length of cable?

Q4.6 Are the coatings/treatments on main tension element discontinued or removed within the anchorage zone?

Responses:

State	Bridge	Q4.4	Q4.5	Q4.6
Alabama	Cochrane Africatown	seven-wire steel strand	bare	NA
Alaska	Sitka Harbor Bridge, Sitka, Alaska	other—galvanized bridge strand	galvanized steel	not known
Alaska	Captain William Moore Bridge, Skagway	other—ASTM Desig A586-86	galvanized steel	not known
California	Sacramento River (Meridian)	steel wire	galvanized steel	no
Delaware	Br. 1-902, SR-1 over the Chesapeake and Delaware Canal, St. Georges, New Castle County, Delaware	seven-wire steel strand	bare	not applicable
Florida	Dame Point Bridge	steel bar or threadbar	epoxy-coated on outside only	not known
Georgia	Talmadge Memorial Bridge, Savannah	seven-wire steel strand	bare	NA
Georgia	Sidney Lanier Bridge, Brunswick	seven-wire steel strand	bare	N/A
Illinois	Quincy Bayview Bridge at Quincy, IL	seven-wire steel strand	epoxy-coated on outside only	not known
Illinois	Clark Bridge at Alton, IL	seven-wire steel strand	epoxy-coated on outside only	not known
Indiana	46-03-7495 EBL	seven-wire steel strand	I think they are bare??	not known
Indiana	I65-68-7910	seven-wire steel strand	I think they are bare??	not known
Iowa	Burlington, IA	seven-wire steel strand—epoxy-coated, 0.6-in. strand in grouted polyethylene pipe	epoxy-coated on outside only—epoxy-coated seven wire strand	yes
Kentucky	William Natcher Bridge, Owensboro, KY	seven-wire steel strand	greased-and-sheathed	Yes—tubes attached to the anchor block provide corrosion protection
Kentucky	William H. Harsha Bridge, Maysville, KY	seven-wire steel strand	greased-and-sheathed	yes
Louisiana	Mississippi River Bridge at Luling, LA	steel wire	bare	not applicable
Mississippi				
Massachusetts	Leonard P. Zakim Bunker Hill Bridge, Boston, MA	seven-wire steel strand	greased-and-sheathed	Yes—sheathing removed in the anchorage zone
Missouri	Bill Emerson Memorial Bridge, Cape Girardeau	seven-wire steel strand	greased-and-sheathed	yes
Ohio	Maumee River Bridge, Toledo	seven-wire steel strand	epoxy-coated inside and outside	yes
South Carolina	Cooper River Bridge	seven-wire steel strand	other-waxed and sheathed	yes
Texas	Veterans Memorial Bridge	seven-wire steel strand	bare	N/A—grouted though entire length and anchorage
Texas	Fred Hartman Bridge	seven-wire steel strand	bare	N/A—grouted though entire length and anchorage

**NCHRP SYNTHESIS TOPIC 35-07—INSPECTION AND MAINTENANCE OF BRIDGE STAY
CABLE SYSTEMS**

State	Bridge	Q4.4	Q4.5	Q4.6
Virginia	I-295 over James River (Varina–Enon Bridge)	seven-wire steel strand	bare	N/A
Washington	Gum Street—Kennewick, WA	steel wire	bare	N/A
Washington	Thea–Foss Tacoma, WA	seven-wire steel strand	bare	N/A
Wisconsin	Sixth Street Viaduct, North Cable Stay	seven-wire steel strand	greased-and-sheathed	yes—removed within anchor zone
Wisconsin	Sixth Street Viaduct, South Cable Stay	seven-wire steel strand	greased-and-sheathed	yes—removed within anchor zone
Alberta/Calgary	Prince's Island (Pedestrian)	steel wire	galvanized steel	not known
Alberta/Calgary	Carburn Park (Pedestrian)	steel bar or threadbar	galvanized steel	not known
Alberta/Calgary	McMahon (Pedestrian)	steel bar or threadbar	galvanized steel	no
Alberta/Calgary	Fox Hollow (Pedestrian)	steel bar or threadbar	galvanized steel	no
Alberta/Calgary	Stoney Trail (Pedestrian)	steel bar or threadbar	galvanized steel	no
British Columbia	Alex Fraser Bridge	Other—7.1-mm diameter galvanized wire to ASTM A586; ult. strength = 1520 MPa; long lay strand assemblies with 109 to 283 wires per assembly	Greased-and-sheathed—galvanized; galvanized wire cable jacketed in polyethylene tube and filled with petroleum wax blocking compound	Yes—zinc-filled cast steel socket at end; grease discontinued in anchorages
Manitoba/Winnipeg	Esplanade Riel	seven-wire steel strand	Galvanized steel, further coated with high density polyethylene	yes, HDPE coating is removed
New Brunswick	Hawkshaw	Steel wire—2-3/8-in. diameter galvanized steel cables. Located near Nackawic NB over the Saint John River between Rte 2 and Rte 105	Galvanized steel—cables are wrapped 5 ft above deck with galvanized wire, also in this area they are coated with Denso Paste and tape	no
New Brunswick	Longs Creek #1	Located on Rte 102 west of Fredricton, NB	galvanized steel	no
New Brunswick	Nackawic River	Located on Rte. 105 in the town of Nackawic	galvanized steel	no
Quebec, Canada	Galipeault	Steel wire—2 9/16-in. diameter bridge strand cable type = 1 x 140 wires	galvanized steel	no
Quebec, Canada	Papineau	Steel wire—strands 2 5/16-in. and 1 5/8-in. diameter. Strand fabricated from 0.192-in. diameter galvanized wire	Galvanized steel—and polyethylene coating	no
Quebec, Canada	Price	Steel wire—galvanized bridge strands. 2.5-in. and 2.56-in. diameter	Galvanized steel—and polyethylene coating 0.209-in. thickness	no

**NCHRP SYNTHESIS TOPIC 35-07—INSPECTION AND MAINTENANCE OF BRIDGE STAY
CABLE SYSTEMS**

Questions:**Q4.7** Type of grout used?**Q4.8** Are filler materials used in the anchorage zone?**Q4.9** Type of anchorage?**Responses:**

State	Bridge	Q4.7	Q4.8	Q4.9
Alabama	Cochrane Africatown	cement–water admixtures	yes, other	conical socket with wedges
Alaska	Sitka Harbor Bridge, Sitka, Alaska	not known	yes, other—liquid polymer sealer	conical socket with wedges
Alaska	Captain William Moore Bridge, Skagway	not known	yes, grease	conical socket with wedges
California	Sacramento River (Meridian)	grout not used	yes, grease	Other—main cables are swedged onto a steel conical threaded coupler that is attached to a threaded HS steel rod, which uses a spherical anchor socket and anchor nut to provide anchorage connection. This system appears to be uniquely designed
Delaware	Br. 1-902, SR-1 over the Chesapeake and Delaware Canal, St. Georges, New Castle County, Delaware	cement–water admixtures	yes, grout	conical socket with wedges
Florida	Dame Point Bridge	not known—a cement grout was used	yes, grout	wedges
Georgia	Talmadge Memorial Bridge, Savannah	cement–water	yes, other—steel shot and epoxy	other—American Stronghold system
Georgia	Sidney Lanier Bridge, Brunswick	cement–water	yes—grout	conical socket with wedges
Illinois	Quincy Bayview Bridge at Quincy, IL	not known	not known	not known
Illinois	Clark Bridge at Alton, IL	not known	not known	not known
Indiana	46-03-7495 EBL	cement–water admixtures	not known	conical socket with wedges
Indiana	I65-68-7910	cement–water admixtures	not known	conical socket with wedges
Iowa	Burlington, IA	not known—grout was used but not sure of content	yes, other—epoxy compound with zinc dust and steel ball	“Hi-Am” type—VSL Stay Cable System 250
Kentucky	William Natcher Bridge, Owensboro, KY	commercial prepackaged grouts	yes, grease	wedges
Kentucky	William H. Harsha Bridge, Maysville, KY	cement–water admixtures	yes, grease	conical socket with wedges
Louisiana	Mississippi River Bridge at Luling, LA	cement–water	yes, other	“Hi-Am” type—each wire also passes through a plate and has a button head anchor
Mississippi				
Massachusetts	Leonard P. Zakim Bunker Hill Bridge, Boston, MA	grout not used	yes, other—wax	wedges
Missouri	Bill Emerson Memorial Bridge, Cape Girardeau	cement–water admixtures	yes, grease	wedges
Ohio	Maumee River Bridge, Toledo	grout not used	yes, grease	wedges
South Carolina	Cooper River Bridge	grout not used	yes, other	wedges

**NCHRP SYNTHESIS TOPIC 35-07—INSPECTION AND MAINTENANCE OF BRIDGE STAY
CABLE SYSTEMS**

State	Bridge	Q4.7	Q4.8	Q4.9
Texas	Veterans Memorial Bridge	cement–water admixtures	yes, other—grout	conical socket with wedges
Texas	Fred Hartman Bridge	cement–water admixtures	yes, other—grout	conical socket with wedges
Virginia	I-295 over James River (Varina–Enon Bridge)	cement–water admixtures	yes, grout	conical socket with wedges
Washington	Gum Street—Kennewick, WA	cement–water	yes, grease	“Hi-Am”-type
Washington	Thea–Foss Tacoma, WA	cement–water	yes, grease	wedges
Wisconsin	Sixth Street Viaduct, North Cable Stay	grout not used	yes, grease, greased at butt end and top end	conical socket with wedges
Wisconsin	Sixth Street Viaduct, South Cable Stay	grout not used	yes, grease, greased at butt end and top end	conical socket with wedges
Alberta/Calgary	Prince’s Island (Pedestrian)	grout not used	no filler	conical socket with wedges
Alberta/Calgary	Carburn Park (Pedestrian)	grout not used	no filler	other—threaded couplers
Alberta/Calgary	McMahon (Pedestrian)	grout not used	no filler	other—threaded coupler
Alberta/Calgary	Fox Hollow (Pedestrian)	grout not used	no filler	other—threaded coupler
Alberta/Calgary	Stoney Trail (Pedestrian)	grout not used	no filler	other—threaded couplers/nuts
British Columbia	Alex Fraser Bridge	grout not used	yes, other—cast steel socket anchorage is filled with zinc	zinc-filled cast steel socket
Manitoba/Winnipeg	Esplanade Riel	grout not used	yes, other, epoxy filler	conical socket with wedges
New Brunswick	Hawkshaw	grout not used	no filler	other—2-3/8-in. forged open strand
New Brunswick	Longs Creek #1	grout not used	no filler	other
New Brunswick	Nackawic River	grout not used	no filler	other
Quebec, Canada	Galipeault	grout not used	no filler	other—closed and open socket
Quebec, Canada	Papineau	not applicable	no filler	other—cylindrical socket into which a threaded rod is screwed
Quebec, Canada	Price	grout not used	no filler	other—cylindrical socket into which a threaded rod is screwed

NCHRP SYNTHESIS TOPIC 35-07—INSPECTION AND MAINTENANCE OF BRIDGE STAY CABLE SYSTEMS

Questions:

Q4.10 Do cables go over “saddles” on the pylons?

Q4.11 Type of cable sheathing used?

Q4.12 Have rain–wind-induced cable vibrations been observed on this bridge?

Responses:

State	Bridge	Q4.10	Q4.11	Q4.12
Alabama	Cochrane Africatown	no	HDPE with PVF Tedlar tape	yes
Alaska	Sitka Harbor Bridge, Sitka, Alaska	no	no sheathing	not known
Alaska	Captain William Moore Bridge, Skagway	no	no sheathing	not known
California	Sacramento River (Meridian)	yes	no sheathing	no
Delaware	Br. 1-902, SR-1 over the Chesapeake and Delaware Canal, St. Georges, New Castle County, Delaware	yes	steel pipe	no
Florida	Dame Point Bridge	no	steel pipe	no
Georgia	Talmadge Memorial Bridge, Savannah	no	HDPE with PVF Tedlar tape	yes
Georgia	Sidney Lanier Bridge, Brunswick	no	HDPE with PVF Tedlar tape	no
Illinois	Quincy Bayview Bridge at Quincy, IL	no	UV-resistant HDPE. Contract in 2003 to wrap cables with elastomeric wrap	no
Illinois	Clark Bridge at Alton, IL	yes	No answer, plans gave contractor option of steel or HDPE	yes—prior to installation of cross cables
Indiana	46-03-7495 EBL	no	polyethylene stay pipes	no
Indiana	I65-68-7910	no	polyethylene stay pipes with pressure sensitive PVF tape	no
Iowa	Burlington, IA	no	HDPE with PVF Tedlar tape	yes
Kentucky	William Natcher Bridge, Owensboro, KY	no	UV-resistant HDPE with spiral on surface	no
Kentucky	William H. Harsha Bridge, Maysville, KY	no	UV-resistant HDPE with spiral on surface	no
Louisiana	Mississippi River Bridge at Luling, LA	no	HDPE with PVF (Tedlar) tape	no—very infrequent, large amplitude motion observed, but not detected
Mississippi				
Massachusetts	Leonard P. Zakim Bunker Hill Bridge, Boston, MA	no	UV-resistant HDPE with spiral on surface	no
Missouri	Bill Emerson Memorial Bridge, Cape Girardeau	no	UV-resistant HDPE with spiral on surface	no
Ohio	Maumee River Bridge, Toledo	Yes—This project actually uses a “cradle,” which separates individual strands within the curved area, avoiding contact stress between them. In that respect, it is different than conventional “saddles”	other—stainless steel	no

NCHRP SYNTHESIS TOPIC 35-07—INSPECTION AND MAINTENANCE OF BRIDGE STAY CABLE SYSTEMS

State	Bridge	Q4.10	Q4.11	Q4.12
South Carolina	Cooper River Bridge	no	UV-resistant HDPE with spiral on surface	N/A
Texas	Veterans Memorial Bridge	yes	HDPE with PVF Tedlar tape	yes
Texas	Fred Hartman Bridge	no	HDPE with PVF Tedlar tape	yes
Virginia	I-295 over James River (Varina–Enon Bridge)	yes	HDPE with PVF Tedlar tape	Not known. No such vibrations have been observed on the Varina–Enon Bridge
Washington	Gum Street—Kennewick, WA	no	HDPE with PVF Tedlar tape	no
Washington	Thea–Foss Tacoma, WA	no	no answer	no
Wisconsin	Sixth Street Viaduct, North Cable Stay	no	UV-resistant HDPE with spiral on surface, white co-extruded HDPE	no—vibration not expected for this small cable-stayed bridge
Wisconsin	Sixth Street Viaduct, South Cable Stay	no	UV-resistant HDPE with spiral on surface, white co-extruded HDPE	no—vibration not expected for this small cable-stayed bridge
Alberta/Calgary	Prince's Island (Pedestrian)	no	no sheathing	yes
Alberta/Calgary	Carburn Park (Pedestrian)	no	no sheathing	not known
Alberta/Calgary	McMahon (Pedestrian)	no	no sheathing	no
Alberta/Calgary	Fox Hollow (Pedestrian)	no	no sheathing	yes
Alberta/Calgary	Stoney Trail (Pedestrian)	no	no sheathing	not known
British Columbia	Alex Fraser Bridge	no	UV-resistant HDPE	yes
Manitoba/Winnipeg	Esplanade Riel	no	UV-resistant HDPE with spiral on surface	no
New Brunswick	Hawkshaw	no	no sheathing	yes
New Brunswick	Longs Creek #1	no	no sheathing	yes
New Brunswick	Nackawic River	no	no sheathing	yes
Quebec, Canada	Galipeault	no	no sheathing	no
Quebec, Canada	Papineau	yes	other—polyethylene coating	no
Quebec, Canada	Price	no	other—polyethylene coating	no, strong wind vibration

**NCHRP SYNTHESIS TOPIC 35-07—INSPECTION AND MAINTENANCE OF BRIDGE STAY
CABLE SYSTEMS**

Questions:**Q4.13** Have MTE corrosion problems been noted?**Q4.14** Do cables have neoprene rings near the top and bottom anchorages?**Q4.15** If there are neoprene rings on the cables, have there been any reports of movements of the rings out of their positions?**Responses:**

State	Bridge	Q4.13	Q4.14	Q4.15
Alabama	Cochrane Africatown	no	yes	yes—due to loosening of retainers, and yes—due to shearing off of retainers
Alaska	Sitka Harbor Bridge, Sitka, Alaska	no	no	not applicable
Alaska	Captain William Moore Bridge, Skagway	no	no	not applicable
California	Sacramento River (Meridian)	no	no	N/A
Delaware	Br. 1-902, SR-1 over the Chesapeake and Delaware Canal, St. Georges, New Castle County, Delaware	Not known—moisture infiltration is suspected; however, due to the limitations of available inspection methods, definitive evidence of corrosion is not available	yes	yes—due to loosening of retainers. Movement observed in outer neoprene ring of anchorage set. No retaining devices were present
Florida	Dame Point Bridge	no	no	N/A
Georgia	Talmadge Memorial Bridge, Savannah	no	yes	yes—due to loosening of retainers, and yes—due to shearing off of retainers
Georgia	Sidney Lanier Bridge, Brunswick	no	yes	no, not known
Illinois	Quincy Bayview Bridge at Quincy, IL	not known	yes	no, not known
Illinois	Clark Bridge at Alton, IL	no	yes	no, not known
Indiana	46-03-7495 EBL	no	yes	no, not known
Indiana	I65-68-7910	no	yes	no, not known
Iowa	Burlington, IA	not known	yes	no, not known
Kentucky	William Natcher Bridge, Owensboro, KY	not known	yes	no, not known
Kentucky	William H. Harsha Bridge, Maysville, KY	no	no	not applicable
Louisiana	Mississippi River Bridge at Luling, LA	yes—see CTL report of July 2004	yes	yes—due to other reasons
Mississippi				
Massachusetts	Leonard P. Zakim Bunker Hill Bridge, Boston, MA	no	no—internal dampers at deck level, stuffing box with HDPE drilled plate and compressive material at pylon	not applicable
Missouri	Bill Emerson Memorial Bridge, Cape Girardeau	no	yes	no, not known
Ohio	Maumee River Bridge, Toledo	no	no	not applicable
South Carolina	Cooper River Bridge	N/A	N/A	N/A
Texas	Veterans Memorial Bridge	no	yes	yes—due to loosening of retainers
Texas	Fred Hartman Bridge	no	yes	yes—due to shearing off of retainers

NCHRP SYNTHESIS TOPIC 35-07—INSPECTION AND MAINTENANCE OF BRIDGE STAY CABLE SYSTEMS

State	Bridge	Q4.13	Q4.14	Q4.15
Virginia	I-295 over James River (Varina–Enon Bridge)	not known	yes—only at the bottom anchorages, since the stays are continuous over the pylons	yes—due to other reasons. Due to the misalignment of stay and guide pipes and no positive restraint was provided to keep neoprene ring from moving outward
Washington	Gum Street—Kennewick, WA	no	not known	no, not known
Washington	Thea–Foss Tacoma, WA	no	yes	no, not known
Wisconsin	Sixth Street Viaduct, North Cable Stay	no	no at top, yes at bottom	no, not known
Wisconsin	Sixth Street Viaduct, South Cable Stay	no	no at top, yes at bottom	no, not known
Alberta/Calgary	Prince’s Island (Pedestrian)	not known	no	not applicable
Alberta/Calgary	Carburn Park (Pedestrian)	not known	no	not applicable
Alberta/Calgary	McMahon (Pedestrian)	not known	no	not applicable
Alberta/Calgary	Fox Hollow (Pedestrian)	yes	no	not applicable
Alberta/Calgary	Stoney Trail (Pedestrian)	no	no	not applicable
British Columbia	Alex Fraser Bridge	no	yes	yes—due to other reasons
Manitoba/Winnipeg	Esplanade Riel	no	yes—these provide damping	no, not known
New Brunswick	Hawkshaw	no	no	not applicable
New Brunswick	Longs Creek #1	no	no	not applicable
New Brunswick	Nackawic River	no	no	not applicable
Quebec, Canada	Galipeault	no	no	not applicable
Quebec, Canada	Papineau	yes—corrosion on threaded rod	yes	no, not known
Quebec, Canada	Price	no	yes	yes—due to shearing off of retainers

NCHRP SYNTHESIS TOPIC 35-07—INSPECTION AND MAINTENANCE OF BRIDGE STAY CABLE SYSTEMS

Questions:

Q4.16 Has moisture been found in any of the internal components of stay cables such as the bottom anchorage areas?

Q4.17 Has fatigue of MTE or other components of stay cables been observed?

Q4.18 Do the cables have viscous dampers installed at deck or tower levels?

Responses:

State	Bridge	Q4.16	Q4.17	Q4.18
Alabama	Cochrane Africatown	yes	no	yes—retrofitted to correct vibrations
Alaska	Sitka Harbor Bridge, Sitka, Alaska	yes—area around each cable was filled with grease	no	no
Alaska	Captain William Moore Bridge, Skagway	yes—area around each cable was filled with grease	no	no
California	Sacramento River (Meridian)	not tested, not known	no	no
Delaware	Br. 1-902, SR-1 over the Chesapeake and Delaware Canal, St. Georges, New Castle County, Delaware	Not known—efflorescence from anchorages as well as protective pipe splice sleeves leads inspectors to believe moisture is infiltrating the cable stay system	no	no
Florida	Dame Point Bridge	yes	no	no
Georgia	Talmadge Memorial Bridge, Savannah	no	no	no
Georgia	Sidney Lanier Bridge, Brunswick	no	no	no
Illinois	Quincy Bayview Bridge at Quincy, IL	yes	no	no
Illinois	Clark Bridge at Alton, IL	Not known—some rust visible at a few anchorages	no	no
Indiana	46-03-7495 EBL	not tested	no	no
Indiana	I65-68-7910	not tested	no	no
Iowa	Burlington, IA	not known	no	no
Kentucky	William Natcher Bridge, Owensboro, KY	yes—moisture was detected during construction when a cable slipped the wedge and had to be replaced, but not since	no	no
Kentucky	William H. Harsha Bridge, Maysville, KY	no	no	no
Louisiana	Mississippi River Bridge at Luling, LA	yes—see July 2004 CTL report	no	no
Mississippi				
Massachusetts	Leonard P. Zakim Bunker Hill Bridge, Boston, MA	no	no	yes, from the beginning—internal dampers at deck level
Missouri	Bill Emerson Memorial Bridge, Cape Girardeau	no	no	no
Ohio	Maumee River Bridge, Toledo	no	no	yes—from the beginning
South Carolina	Cooper River Bridge	N/A	N/A	yes—from the beginning

NCHRP SYNTHESIS TOPIC 35-07—INSPECTION AND MAINTENANCE OF BRIDGE STAY CABLE SYSTEMS

State	Bridge	Q4.16	Q4.17	Q4.18
Texas	Veterans Memorial Bridge	no	no	yes—retrofitted to correct vibrations—presently being installed
Texas	Fred Hartman Bridge	no	yes—possible wire breaks have been detected by acoustic monitoring system	yes—retrofitted to correct vibrations; presently being installed
Virginia	I-295 over James River (Varina–Enon Bridge)	no	no—the forces obtained in the initial in-depth inspection indicated a good correlation with the designer's predicted forces	no—details are included in the maintenance manual (Appendix F) as an alternate stay damper system
Washington	Gum Street—Kennewick, WA	no	no	no
Washington	Thea–Foss Tacoma, WA	no	no	no
Wisconsin	Sixth Street Viaduct, North Cable Stay	no	no	no
Wisconsin	Sixth Street Viaduct, South Cable Stay	no	no	no
Alberta/Calgary	Prince's Island (Pedestrian)	not tested	not known	no
Alberta/Calgary	Carburn Park (Pedestrian)	not tested	no	no
Alberta/Calgary	McMahon (Pedestrian)	not tested	no	no
Alberta/Calgary	Fox Hollow (Pedestrian)	no	yes	no
Alberta/Calgary	Stoney Trail (Pedestrian)	no	no	no
British Columbia	Alex Fraser Bridge	no	no	no
Manitoba/Winnipeg	Esplanade Riel	no	no	no—damping via neoprene rings
New Brunswick	Hawkshaw	not tested	no	yes—retrofitted to correct vibrations. Wood clamps placed at 1/3 points of the six cables
New Brunswick	Longs Creek #1	not tested	no	yes—retrofitted to correct vibrations
New Brunswick	Nackawic River	not tested	no	yes—retrofitted to correct vibrations
Quebec, Canada	Galipeault	no	no	no
Quebec, Canada	Papineau	no	no	no
Quebec, Canada	Price	no	yes—see question no. 4-27	no

NCHRP SYNTHESIS TOPIC 35-07—INSPECTION AND MAINTENANCE OF BRIDGE STAY CABLE SYSTEMS

Questions:

Q4.19 Do the cables have cross cables installed between them?

Q4.20 Do cables have other dampers (other than viscous or neoprene rings) to control vibrations?

Q4.21 Has cracking of the cable sheathing or sheathing connections been noted?

Responses:

State	Bridge	Q4.19	Q4.20	Q4.21
Alabama	Cochrane Africatown	no	no	no
Alaska	Sitka Harbor Bridge, Sitka, Alaska	no	no	not applicable
Alaska	Captain William Moore Bridge, Skagway	no	no	not applicable
California	Sacramento River (Meridian)	no	Cables utilize clamps near the saddles to retain separation of the cable groups; these may provide some unintentional damping	N/A
Delaware	Br. 1-902, SR-1 over the Chesapeake and Delaware Canal, St. Georges, New Castle County, Delaware	no	no	yes, sheathing—cracking of the steel protective pipe has been noted on the uppermost stay cable of the north pylon. Cracking has been attributed to the position of a construction grout vent hole at a high stress location
Florida	Dame Point Bridge	yes—from the beginning	no	yes—connections
Georgia	Talmadge Memorial Bridge, Savannah	no	no	no
Georgia	Sidney Lanier Bridge, Brunswick	no	no	no
Illinois	Quincy Bayview Bridge at Quincy, IL	no	no	yes—sheathing
Illinois	Clark Bridge at Alton, IL	yes—retrofitted to correct vibrations	no	not known
Indiana	46-03-7495 EBL	yes—from the beginning	no	no
Indiana	I65-68-7910	no	no	no
Iowa	Burlington, IA	yes—retrofitted to correct vibrations	yes, other—Tie cables	no
Kentucky	William Natcher Bridge, Owensboro, KY	yes—from the beginning	no	no
Kentucky	William H. Harsha Bridge, Maysville, KY	yes—from the beginning	no	no answer
Louisiana	Mississippi River Bridge at Luling, LA	no	no	yes—sheathing
Mississippi				
Massachusetts	Leonard P. Zakim Bunker Hill Bridge, Boston, MA	yes—from the beginning	no	no
Missouri	Bill Emerson Memorial Bridge, Cape Girardeau	yes—from the beginning	no	no
Ohio	Maumee River Bridge, Toledo	no	no	no
South Carolina	Cooper River Bridge	no—bridge not finished. A provisional feature if needed	yes—external hydraulic dampers	N/A
Texas	Veterans Memorial Bridge	no	no	no

NCHRP SYNTHESIS TOPIC 35-07—INSPECTION AND MAINTENANCE OF BRIDGE STAY CABLE SYSTEMS

State	Bridge	Q4.19	Q4.20	Q4.21
Texas	Fred Hartman Bridge	yes—retrofitted to correct vibrations; presently being installed	no	no
Virginia	I-295 over James River (Varina–Enon Bridge)	no	no	no
Washington	Gum Street—Kennewick, WA	no	no	no
Washington	Thea–Foss Tacoma, WA	no	no	no
Wisconsin	Sixth Street Viaduct, North Cable Stay	no	no	no
Wisconsin	Sixth Street Viaduct, South Cable Stay	no	no	no
Alberta/Calgary	Prince's Island (Pedestrian)	no	no	not applicable
Alberta/Calgary	Carburn Park (Pedestrian)	no	no	not applicable
Alberta/Calgary	McMahon (Pedestrian)	yes—from the beginning	no	not applicable
Alberta/Calgary	Fox Hollow (Pedestrian)	yes—retrofitted to correct vibrations	no	not applicable
Alberta/Calgary	Stoney Trail (Pedestrian)	yes—from the beginning	no	no
British Columbia	Alex Fraser Bridge	no	no	no
Manitoba/Winnipeg	Esplanade Riel	no	no	no
New Brunswick	Hawkshaw	no	yes—other dampers, wood clamps	not applicable
New Brunswick	Longs Creek #1	no	yes—other dampers	not applicable
New Brunswick	Nackawic River	no	yes—other dampers	not applicable
Quebec, Canada	Galipeault	no	no	not applicable
Quebec, Canada	Papineau	no	no	no
Quebec, Canada	Price	no	no	no

**NCHRP SYNTHESIS TOPIC 35-07—INSPECTION AND MAINTENANCE OF BRIDGE STAY
CABLE SYSTEMS**

Questions:

Q4.22 Has cracking or misalignment of the guide pipes been noted?

Q4.23 If there is protective tape wrapped around the cable sheathing; have there been reports of deterioration of the tape?

Q4.24 Have any problems associated with neoprene boots been noted?

Responses:

State	Bridge	Q4.22	Q4.23	Q4.24
Alabama	Cochrane Africatown	yes—misalignment	yes—minor damage	yes
Alaska	Sitka Harbor Bridge, Sitka, Alaska	not known	not applicable	no
Alaska	Captain William Moore Bridge, Skagway	not known	not applicable	no
California	Sacramento River (Meridian)	N/A	N/A	The neoprene seals noted above that retain grease in the anchorage areas leak
Delaware	Br. 1-902, SR-1 over the Chesapeake and Delaware Canal, St. Georges, New Castle County, Delaware	no	not applicable—the protective steel pipe is painted	yes—minor tearing of one neoprene boot has been observed
Florida	Dame Point Bridge	no	N/A	no
Georgia	Talmadge Memorial Bridge, Savannah	yes—cracking	no	no
Georgia	Sidney Lanier Bridge, Brunswick	no	no	no
Illinois	Quincy Bayview Bridge at Quincy, IL	no	N/A—see comment above about wrapping in 2003	no
Illinois	Clark Bridge at Alton, IL	no	no	no
Indiana	46-03-7495 EBL	no	N/A	no
Indiana	I65-68-7910	not applicable	no	no
Iowa	Burlington, IA	no	yes—minor damage	no
Kentucky	William Natcher Bridge, Owensboro, KY	no	no	no
Kentucky	William H. Harsha Bridge, Maysville, KY	no	not applicable	no
Louisiana	Mississippi River Bridge at Luling, LA	no	yes—moderate damage—damaged areas of undetermined cause. Look to be impact but very high off deck	yes—not boots, washers—split neoprene washers are held in place by bolts and caulked
Mississippi				
Massachusetts	Leonard P. Zakim Bunker Hill Bridge, Boston, MA	no	not applicable	no—not applicable
Missouri	Bill Emerson Memorial Bridge, Cape Girardeau	no	no	no
Ohio	Maumee River Bridge, Toledo	no	not applicable	no
South Carolina	Cooper River Bridge	not known	N/A	not known
Texas	Veterans Memorial Bridge	no	yes—minor damage	no
Texas	Fred Hartman Bridge	no	yes—minor damage	no
Virginia	I-295 over James River (Varina–Enon Bridge)	yes—misalignment	no	yes—minor cracks and tears have been noted in 6 of the 52 neoprene boots
Washington	Gum Street—Kennewick, WA	no	yes—extensive damage	yes
Washington	Thea–Foss Tacoma, WA	no	yes—minor damage	no

NCHRP SYNTHESIS TOPIC 35-07—INSPECTION AND MAINTENANCE OF BRIDGE STAY CABLE SYSTEMS

State	Bridge	Q4.22	Q4.23	Q4.24
Wisconsin	Sixth Street Viaduct, North Cable Stay	yes—misalignment, top guide pipes not concentric with PE is the only misalignment	no	no
Wisconsin	Sixth Street Viaduct, South Cable Stay	yes—misalignment, top guide pipes not concentric with PE is the only misalignment	no	no
Alberta/Calgary	Prince's Island (Pedestrian)	not applicable	not applicable	not known
Alberta/Calgary	Carburn Park (Pedestrian)	not applicable	not applicable	not known
Alberta/Calgary	McMahon (Pedestrian)	not applicable	not applicable	not known
Alberta/Calgary	Fox Hollow (Pedestrian)	not applicable	not applicable	no
Alberta/Calgary	Stoney Trail (Pedestrian)	no	not known	no
British Columbia	Alex Fraser Bridge	not applicable	not applicable—repairs used protective tape, no deterioration observed	yes—shifting and splitting
Manitoba/Winnipeg	Esplanade Riel	no	not applicable	no
New Brunswick	Hawkshaw	not applicable	no	
New Brunswick	Longs Creek #1	not applicable	yes—minor damage	
New Brunswick	Nackawic River	not applicable	no	
Quebec, Canada	Galipeault	not applicable	not applicable	no
Quebec, Canada	Papineau	not applicable	not applicable	no
Quebec, Canada	Price	not applicable	not applicable	no

NCHRP SYNTHESIS TOPIC 35-07—INSPECTION AND MAINTENANCE OF BRIDGE STAY CABLE SYSTEMS

Questions:

Q4.25 Types of non-destructive tests that any of the cables on this bridge have been subjected to?

Q4.26 Types of sensor-based, long-term monitoring performed on the cables?

Q4.27 Have the cables on this bridge (or any of their components) been repaired?

Responses:

State	Bridge	Q4.25	Q4.26	Q4.27
Alabama	Cochrane Africatown	Ultrasonic and vibration-based force measurements	vibration monitoring	yes—some neoprene boots were replaced
Alaska	Sitka Harbor Bridge, Sitka, Alaska	Vibration-based force measurements	not performed	no—during mid-1990s cables were removed, inspected, and replaced after no defects observed
Alaska	Captain William Moore Bridge, Skagway	Vibration-based force measurements	not performed	Bridge redesigned for higher load capacity. New cables were installed during mid-1990s
California	Sacramento River (Meridian)	X-ray, primary inspection method is VT. "MINAC" Radiographic inspection was used once in 1989 to inspect the swedged anchorage components as a demonstration of the technology	not performed	no
Delaware	Br. 1-902, SR-1 over the Chesapeake and Delaware Canal, St. Georges, New Castle County, Delaware	Other—a borescope has been utilized to view the guidepipe area of select cable stays for moisture, fatigue, deterioration, and corrosion. An attempt was made to remove select anchorage caps; however, grout inside the anchorage caps made removal difficult. High-powered X-ray inspection of the cable stays was considered. This method has not been employed due to concerns for protection of the public and personnel during testing, access limitations, and uncertainty of the results of such investigations due to the complicated geometry of the subject area	Not performed. Vibration monitoring equipment has been installed on the cable stays by FHWA. However, this equipment is currently not operating and data are not available.	yes—the out of position neoprene dampers have been repositioned and set screws have been installed to secure the position of the outer neoprene damper rings on all cable stays
Florida	Dame Point Bridge	not performed	not performed	no
Georgia	Talmadge Memorial Bridge, Savannah	Vibration-based force measurements	not performed	no

NCHRP SYNTHESIS TOPIC 35-07—INSPECTION AND MAINTENANCE OF BRIDGE STAY CABLE SYSTEMS

State	Bridge	Q4.25	Q4.26	Q4.27
Georgia	Sidney Lanier Bridge, Brunswick	not performed	not performed	no
Illinois	Quincy Bayview Bridge at Quincy, IL	not performed	acoustic wire break detection	yes—previous intermittent wrapping. See comment above about complete wrapping in 2003
Illinois	Clark Bridge at Alton, IL	not performed	not performed	no
Indiana	46-03-7495 EBL	not performed	not performed	no
Indiana	I65-68-7910	not performed	not performed	no
Iowa	Burlington, IA	Vibration-based force measurements. Vibration measurements were done during construction to determine amount of force in cables	not performed	no
Kentucky	William Natcher Bridge, Owensboro, KY	not performed	not performed	no
Kentucky	William H. Harsha Bridge, Maysville, KY	not performed	not performed	no
Louisiana	Mississippi River Bridge at Luling, LA	Vibration-based force measurements	vibration monitoring	yes—splits in early years repaired by heat welding, wrapped with Tedlar tape
Mississippi				
Massachusetts	Leonard P. Zakim Bunker Hill Bridge, Boston, MA	not performed	not performed	no
Missouri	Bill Emerson Memorial Bridge, Cape Girardeau	not performed	not performed	yes—splices were added to HDPE sheathing during construction of a couple of cables
Ohio	Maumee River Bridge, Toledo	not performed	not performed	no
South Carolina	Cooper River Bridge	not performed	not performed	no
Texas	Veterans Memorial Bridge	Vibration-based force measurements, used to aid in the design of viscous dampers for the bridge. Performed periodically to compare predampened response to post-dampened response	Acoustic wire break detection, vibration monitoring, other. Have long-term weather monitoring to associate with oscillation events	yes—retightened the retainers for the neoprene rings
Texas	Fred Hartman Bridge	Vibration-based force measurements, used to aid in the design of viscous dampers for the bridge. Performed periodically to compare predampened response to post-dampened response	Acoustic wire break detection, vibration monitoring, other—have long-term weather monitoring to associate with oscillation events	yes—rewelded and stiffened guide pipe. Replaced initial restrainer system after fatigue and failure of original restrainer cables
Virginia	I-295 over James River (Varina–Enon Bridge)	Vibration-based force measurements. Tension force measurement tests were performed by Construction Technology Laboratory, Inc. (CTL) in April 1999	not known	no
Washington	Gum Street—Kennewick, WA	magnetic	not performed	no

NCHRP SYNTHESIS TOPIC 35-07—INSPECTION AND MAINTENANCE OF BRIDGE STAY CABLE SYSTEMS

State	Bridge	Q4.25	Q4.26	Q4.27
Washington	Thea-Foss Tacoma, WA	not performed	not performed	no
Wisconsin	Sixth Street Viaduct, North Cable Stay	Not performed. By requirements of supplier, full-scale stay cable fatigue tests by Construction Technology Laboratories in Skokie, IL and Technical University of Munich; no wire breaks during 2 million cycle fatigue tests. During reload and static tests, failed to meet min. tensile force of 95% GUTS (only 90%). Therefore, added strands at all locations	not performed	no
Wisconsin	Sixth Street Viaduct, South Cable Stay	Not performed. By requirements of supplier, full-scale stay cable fatigue tests by Construction Technology Laboratories in Skokie, IL and Technical University of Munich; no wire breaks during 2 million cycle fatigue tests. During reload and static tests, failed to meet min. tensile force of 95% GUTS (only 90%). Therefore, added strands at all locations	not performed	no
Alberta/Calgary	Prince's Island (Pedestrian)	not performed	not performed	no
Alberta/Calgary	Carburn Park (Pedestrian)	not performed	not performed	no
Alberta/Calgary	McMahon (Pedestrian)	not performed	not performed	no
Alberta/Calgary	Fox Hollow (Pedestrian)	magnetic, ultrasonic, and vibration-based force measurements	not performed	yes—two bars failed and were replaced. One additional bar replaced due to corrosion
Alberta/Calgary	Stoney Trail (Pedestrian)	not performed	not performed	no
British Columbia	Alex Fraser Bridge	not performed	Acoustic wire break detection—performed short term, now discontinued	yes—boots replaced or repaired, sheaths repaired
Manitoba/Winnipeg	Esplanade Riel	Not performed. Vibration-based force measurements on selected MTE will be performed and continuously monitored using a permanent SHM system	vibration monitoring	yes—extensions to permit additional thermal contraction capability of the HDPE sheathing installed. Warranty covered this
New Brunswick	Hawkshaw	not performed	not performed	no
New Brunswick	Longs Creek #1	not performed	not performed	no
New Brunswick	Nackawic River	not performed	not performed	no
Quebec, Canada	Galipeault	other—laser-based force measurements	not performed	no
Quebec, Canada	Papineau	not performed	not performed	no
Quebec, Canada	Price	not performed	not performed	yes—broken anchor bolt. Failure of two 5-in. anchor bolts in the anchorage zone

NCHRP SYNTHESIS TOPIC 35-07—INSPECTION AND MAINTENANCE OF BRIDGE STAY CABLE SYSTEMS

Questions:

Q4.28 Has the sheathing been partially removed on any of the cables to examine condition of grout (if applicable) and/or the MTE?

Q4.29 Can the strands or cables be replaced if needed?

Q4.30 Do you have an inspection and maintenance manual for this bridge?

Responses:

State	Bridge	Q4.28	Q4.29	Q4.30
Alabama	Cochrane Africatown	yes—thorough inspection performed. Selected cables were opened up where voids in grout were detected	yes—individual strands cannot be replaced, but an entire stay can be replaced	yes
Alaska	Sitka Harbor Bridge, Sitka, Alaska	not applicable	yes	no
Alaska	Captain William Moore Bridge, Skagway	not applicable	yes	no
California	Sacramento River (Meridian)	N/A	yes—as this swing bridge only fully utilizes the cables to support the spans in the open condition, cable replacement would be relatively straightforward	no
Delaware	Br. 1-902, SR-1 over the Chesapeake and Delaware Canal, St. Georges, New Castle County, Delaware	no—limited investigation of the cable stay grout has been performed via the open construction grout vents in the saddle pipe area of the cable stay	yes—the original design accounted for the replacement of the stay cables (one at a time)	yes
Florida	Dame Point Bridge	no	no	yes
Georgia	Talmadge Memorial Bridge, Savannah	yes—some removal and inspection was done in 2002. Grout was found to be satisfactory	yes	yes
Georgia	Sidney Lanier Bridge, Brunswick	no answer	yes	yes
Illinois	Quincy Bayview Bridge at Quincy, IL	no	yes	no
Illinois	Clark Bridge at Alton, IL	no	yes	yes, not included for security reasons
Indiana	46-03-7495 EBL	no	Not known—I would hope that they could be if needed	yes
Indiana	I65-68-7910	no	Not known—I would hope that they could be if needed	yes
Iowa	Burlington, IA	no	yes	yes
Kentucky	William Natcher Bridge, Owensboro, KY	no	yes—cable only. Strand could not be replaced	yes
Kentucky	William H. Harsha Bridge, Maysville, KY	no	yes	yes
Louisiana	Mississippi River Bridge at Luling, LA	no—planned for next inspection contract phase with CTL	yes—not easily	no
Mississippi				

**NCHRP SYNTHESIS TOPIC 35-07—INSPECTION AND MAINTENANCE OF BRIDGE STAY
CABLE SYSTEMS**

State	Bridge	Q4.28	Q4.29	Q4.30
Massachusetts	Leonard P. Zakim Bunker Hill Bridge, Boston, MA	no	yes	yes
Missouri	Bill Emerson Memorial Bridge, Cape Girardeau	no	yes	no
Ohio	Maumee River Bridge, Toledo	no	yes	no answer
South Carolina	Cooper River Bridge	not known	yes	yes—required submittal upon completion in 2005
Texas	Veterans Memorial Bridge	no	yes	yes
Texas	Fred Hartman Bridge	yes—sheathing was removed to observe the condition of grout. Grout appeared to be in good/sound condition	yes	yes
Virginia	I-295 over James River (Varina–Enon Bridge)	no	yes	yes
Washington	Gum Street—Kennewick, WA	no	not known	yes
Washington	Thea–Foss Tacoma, WA	no	not known	yes
Wisconsin	Sixth Street Viaduct, North Cable Stay	no	yes	yes
Wisconsin	Sixth Street Viaduct, South Cable Stay	no	yes	yes
Alberta/Calgary	Prince's Island (Pedestrian)	not applicable	no	no
Alberta/Calgary	Carburn Park (Pedestrian)	not applicable	yes	no
Alberta/Calgary	McMahon (Pedestrian)	not applicable	yes	no
Alberta/Calgary	Fox Hollow (Pedestrian)	not applicable	yes	no
Alberta/Calgary	Stoney Trail (Pedestrian)	no	yes	no
British Columbia	Alex Fraser Bridge	no	yes	yes
Manitoba/Winnipeg	Esplanade Riel	no	yes	no—since this is a new bridge this should be an upcoming deliverable from our consultant
New Brunswick	Hawkshaw	not applicable	not known	no
New Brunswick	Longs Creek #1	not applicable	not known	no
New Brunswick	Nackawic River	not applicable	not known	no
Quebec, Canada	Galipeault	not applicable	yes	no
Quebec, Canada	Papineau	no	no	no
Quebec, Canada	Price	no	yes	no

NCHRP SYNTHESIS TOPIC 35-07—INSPECTION AND MAINTENANCE OF BRIDGE STAY CABLE SYSTEMS

Questions:

Q5 Based on your experience and in general, do you believe that the current inspection, testing, monitoring, and repair methods available to you for stay cables are effective and adequate?

Q6 Please comment on the effectiveness of any non-destructive test methods for inspections of stay cables that you may be familiar with. These methods include (but are not limited to) ultrasonic testing, magnetic inspections, laser-based force measurements, X-ray imaging, etc. If possible, please comment on issues such as practicality, cost, duration, impact on traffic, and any other factors that you consider important.

Q7 Please comment on the effectiveness of any cable vibration control measures that you may be familiar with. Examples include installation of cross cables, viscous dampers, neoprene rings, etc.

Responses:

State	Bridge	Q5	Q6	Q7
Alabama	Cochrane Africatown	yes	Several non-destructive tests were run after an extreme oscillation event. Practically all the above were performed to determine if there was any loss of force in the stays. Geometric, physical, and visual tests were performed. The only discoveries were deficiencies in the original construction, which were corrected	We realigned stay pipes and replaced neoprene rings and keeper rings. Also, external hydraulic dampers were installed on the longer stays
Alaska	Sitka Harbor Bridge, Sitka, Alaska	Not known—the cables on both bridges were inspected during the mid-1990s. Cables on Captain William Moore were replaced due to an upgrade of the structure. Cables on the Sitka Harbor Bridge, were removed, inspected, and reinstalled. No problems were reported with any of the cables during the mid-1990 inspection	The fundamental frequency of the cables was recorded. Alaska DOT&PF will monitor the cables and attempt to determine if the fundamental frequency of the cables has changed	N/A
Alaska	Captain William Moore Bridge, Skagway	Not known—the cables on both bridges were inspected during the mid-1990s. Cables on Captain William Moore were replaced due to an upgrade of the structure. Cables on the Sitka Harbor Bridge were removed, inspected, and reinstalled. No problems were reported with any of the cables during the mid-1990 inspection	The fundamental frequency of the cables was recorded. Alaska DOT&PF will monitor the cables and attempt to determine if the fundamental frequency of the cables has changed	N/A

NCHRP SYNTHESIS TOPIC 35-07—INSPECTION AND MAINTENANCE OF BRIDGE STAY CABLE SYSTEMS

State	Bridge	Q5	Q6	Q7
California	Sacramento River (Meridian)	not known	Used radiographic testing once on this structure. It was costly and impractical, but did appear to give satisfactory results. Would not use this method for routine inspections on this bridge	no answer
Delaware	Br. 1-902, SR-1 over the Chesapeake and Delaware Canal, St. Georges, New Castle County, Delaware	no— the use of the steel protective pipe limits the inspection methods available to investigate the condition of the stay cables	The presence of the steel protective pipe limits the effectiveness of many available testing methods, particularly magnetic-based methods. As noted above, X-ray imaging of the cable stays was considered and dismissed. Several concerns were encountered with this method including protection of public and working personnel during the exposure, access, and holding the equipment at the higher elevations of the cable stay, and scheduling of the equipment. Interpretation of the image was also a concern. It is believed that the multiple materials (steel, grout, steel strand) that comprise the cable stays combined with the changing geometry would make interpretation of the image difficult and would not allow for an accurate understanding of the conditions. Our understanding is that the X-ray imaging would only be able to detect gross section loss of the stay and is not precise enough to discern the onset or early stages of corrosion. Finally, when the X-ray imaging method was considered, it only allowed a view of a discrete section of the cable stay as opposed to a global or "traveling" operation, which would allow an	The neoprene dampers of the C&D Canal Bridge appear to operating adequately, particularly since the repositioning and installation of set screws into the outer neoprene rings. Excessive vibration of the stay cables has not been noted. No other cable stay damping systems or grout spalls have been observed in the grout bedding present on the bridge (cable stays saddle area) where the upper stays (13 thru 16) enter the pylon. This spalling has been attributed to minor vibrations of the stays

NCHRP SYNTHESIS TOPIC 35-07—INSPECTION AND MAINTENANCE OF BRIDGE STAY CABLE SYSTEMS

State	Bridge	Q5	Q6	Q7
			investigation of the entire length of the cable stay. Implementation of laser-based cable stay force measurements are being considered by the department to establish baseline force data for the cable stays	
Florida	Dame Point Bridge	not known	Non-destructive testing is needed to determine the condition of tension bars inside the steel casing of the cables	Cross cables are installed on the bridge and from time to time they sag and need to be retightened
Georgia	Talmadge Memorial Bridge, Savannah	yes	Laser-based force measurements will give results that will indicate if a cable is deviating from the trending values of the other cables. It may not give you an accurate value of the force in a cable. It is relatively easy and inexpensive to perform	These methods are all effective in controlling free vibrations of the cables. Helical strakes formed in the cable neoprene sheathing are also effective
Georgia	Sidney Lanier Bridge, Brunswick	yes	Laser-based force measurements will give results that will indicate if a cable is deviating from the trending values of the other cables. It may not give you an accurate value of the force in a cable. It is relatively easy and inexpensive to perform	These methods are all effective in controlling free vibrations of the cables. Helical strakes formed in the cable neoprene sheathing are also effective
Illinois	Quincy Bayview Bridge at Quincy, IL	no	no answer	Cross cables on the Clark Bridge have been effective
Illinois	Clark Bridge at Alton, IL	no	no answer	Cross cables on the Clark Bridge have been effective
Indiana	46-03-7495 EBL	no—we will be having these two bridges inspected and tested by a consultant in the next 1–2 year time frame. We are just beginning to get a good understanding of the possible problems that we may encounter on these bridges over the coming years	We have not yet done any testing on these two cable-stayed bridges, but probably will be doing so in the next 1–2 years	The ones on the SR-46 bridge seem to be OK. There are also some on the new US-231 bridge over the Ohio River that we share with Kentucky (Kentucky is the lead state for this bridge). They seem to be OK also. However, I have not been at either of these bridges during bad weather
Indiana	I65-68-7910	no—we will be having these two bridges inspected and tested by a consultant in the next 1–2 year time frame. We are just beginning to get a good understanding of the	We have not yet done any testing on these two cable-stayed bridges, but probably will be doing so in the next 1–2 years	The ones on the SR-46 bridge seem to be OK. There are also some on the new US-231 bridge over the Ohio River that we share with Kentucky (Kentucky is

NCHRP SYNTHESIS TOPIC 35-07—INSPECTION AND MAINTENANCE OF BRIDGE STAY CABLE SYSTEMS

State	Bridge	Q5	Q6	Q7
		possible problems that we may encounter on these bridges over the coming years		the lead state for this bridge). They seem to be OK also. However, I have not been at either of these bridges during bad weather
Iowa	Burlington, IA	no—need way to inspect cable	Have not had experience with non-destructive test methods	Have not had vibration problems since cross cables were installed
Kentucky	William Natcher Bridge, Owensboro, KY	no—there are technical limitations that prevent inspection of the stay cables, especially the anchorage area. Technical breakthrough is required	The only problem is the anchorage area. So far no method is available for inspection. (PB) I see additional problems with inspection of the grout-filled cables. (DKD)	Wind damper is a high tech method that is very effective in most cases. However, the dampers are delicate mechanism that needs constant maintenance like any machine. Only the exterior dampers allow inspection and maintenance. Internal dampers are difficult to access for inspection. Any inspection and maintenance and/or replacement will be a major project. Another major concern is that the method to determine the damper's condition is still not available. Therefore, after only a few years, no one will know whether the installed dampers are still working. On the other hand, the cross cables will work as long as they are in place. The condition of the cross cables can be easily observed from the deck. Replacement of the cross ties is not a major operation. Therefore, before the damper is improved, the cross cable is the better and sure solution. (PB)
Kentucky	William H. Harsha Bridge, Maysville, KY	no—there are technical limitations that prevent inspection of the stay cables, especially the anchorage area. Technical breakthrough is required	The only problem is the anchorage area. So far no method is available for inspection. (PB) I see additional problems with inspection of the grout-filled cables. (DKD)	Wind damper is a high tech method that is very effective in most cases. However, the dampers are delicate mechanisms that need constant maintenance like any machine. Only the exterior dampers allow inspection and maintenance. Internal dampers are difficult to access for inspection.

NCHRP SYNTHESIS TOPIC 35-07—INSPECTION AND MAINTENANCE OF BRIDGE STAY CABLE SYSTEMS

State	Bridge	Q5	Q6	Q7
				<p>Any inspection and maintenance and/or replacement will be a major project. Another major concern is that the method to determine the damper's condition is still not available. Therefore, after only a few years, no one will know whether the installed dampers are still working. On the other hand, the cross cables will work as long as they are in place. The condition of the cross cables can be easily observed from the deck. Replacement of the cross ties is not a major operation. Therefore, before the damper is improved, the cross cable is the better and sure solution. (PB)</p>
Louisiana	Mississippi River Bridge at Luling, LA	Not known—our vibration tests over time have indicated consistent cable loads; we are still unable to call the wires pristine	Vibration-based cable load determination—effective and inexpensive; X-ray—expensive, slow, very questionable ability to detect wire defects; Magnetic inspection—used to rapidly, effectively inspect mine cables—but the cables move past the inspection unit, which would need to be reversed on a cable bridge; Impulse radar—good for detecting grout defects; Sonic methods—dampened to the point of being ineffective	Luling has neoprene rings, but these are relatively very small considering the large diameter of the Luling cables and are there mainly to seal the anchors, but perhaps they also dampen the cables. CTL will check into this
Mississippi		Not known—we are several years away from completion of the first cable-stayed bridge for which Arkansas will have responsibility for inspection/maintenance/not known	No comment/not known	No comment—we are currently constructing a cable-stayed bridge on US-82 over the Mississippi River near Greenville, MS. Mississippi is responsible for overseeing the construction and Arkansas will be responsible for the maintenance. We are sharing the costs associated with both construction and maintenance. We are

NCHRP SYNTHESIS TOPIC 35-07—INSPECTION AND MAINTENANCE OF BRIDGE STAY CABLE SYSTEMS

State	Bridge	Q5	Q6	Q7
				using cable ties and cable stay sheathing with a helical drip bead to control the cable vibration. We considered using dampners and a combination of dampners and cable ties. However, we were not comfortable with the reliability of dampners and felt the cable ties have a long standing proven record. A visual inspection would show problems with the ties, where with the dampners it is not so easy to determine if they are working properly
Massachusetts	Leonard P. Zakim Bunker Hill Bridge, Boston, MA	yes	Have not yet used any NDT methods for stay cable inspection	It is our opinion that neoprene rings will not work as intended. Either internal or external viscous dampers are needed. Cross cables are not needed in shorter spans
Missouri	Bill Emerson Memorial Bridge, Cape Girardeau	Not known—MoDOT has no related experience	MoDOT has no related experience	Cross cables have been installed on this bridge as the most effective, positive method to eliminate cable vibrations. We understand that worldwide research is being conducted to maximize the efficiency of dampers and to determine, mathematically, when they are and are not required
Ohio	Maumee River Bridge, Toledo	yes—while better methods may be developed in the future, the current methods are both effective and adequate. The most likely location of cable issues on all such bridges is at the anchor areas. By the nature of the anchor being embedded in massive concrete or steel areas, direct access to inspect the MTE is generally impractical	no answer	Volumes can be written on this topic. The short version is that any actual "damping" added to the cable is highly effective since by its nature the cable has very little. Other control measures have had various degrees of success. In most cases, the success or lack of success has been related to the actual details, not so much in the selected approach to the issue
South Carolina	Cooper River Bridge	yes	no comment	Viscous dampers for all cables and

NCHRP SYNTHESIS TOPIC 35-07—INSPECTION AND MAINTENANCE OF BRIDGE STAY CABLE SYSTEMS

State	Bridge	Q5	Q6	Q7
				<p>additional external dampers for the longest cables are in plans and will be installed. Cross cable dampers are a future consideration. Provisions for future installation of cross cables will be installed. If the system of viscous and external dampers is inadequate, the cross cables can be installed</p>
Texas	Veterans Memorial Bridge	<p>yes—owners are unable to non-destructively evaluate the condition of stay cables and anchorages</p>	<p>TxDOT has employed vibration-based force measurements to refine the model used for designing viscous dampers on each of the cable stay bridges. The technique seemed to give good correlation cable dimensions and damping requirements. The technique requires some traffic control and depending on the number of lanes carried by the structure could produce minor to significant traffic disruption. At least one lane and the shoulder will need to be closed; therefore, if the bridge is narrow with a small number of lanes carrying two-way traffic the disruption could be considerable. This could last for several weeks if there are a large number of stays that need to be tested. The cost can run anywhere from \$50,000 to \$75,000 per bridge per test event depending on the size of the structure</p>	<p>The only cable vibration control measures that Texas has experience with at this time are cross tie cables and neoprene rings. The neoprene rings do not appear to offer a measurable amount of dampening and based on the department's experience should not be considered as a primary damping mechanism. The cross tie system that the department has employed has been effective in reducing the extreme vibration events, but vibrations of an amplitude that causes concern still occur. Texas is presently installing viscous damping systems of each of the cable stay bridges in the state. On the Fred Hartman Bridge these will be installed in conjunction with cross tie cables. It is hoped that this combination will effectively eliminate the occurrence and amplitude of any vibrations</p>
Texas	Fred Hartman Bridge	<p>yes—owners are unable to non-destructively evaluate the condition of stay cables and anchorages</p>	<p>TxDOT has employed vibration-based force measurements to refine the model used for designing viscous dampers on each of the cable stay bridges. The technique seemed to give good correlation cable dimensions and damping requirements.</p>	<p>The only cable vibration control measures that Texas has experience with at this time are cross tie cables and neoprene rings. The neoprene rings do not appear to offer a measurable amount of dampening, and based on the</p>

NCHRP SYNTHESIS TOPIC 35-07—INSPECTION AND MAINTENANCE OF BRIDGE STAY CABLE SYSTEMS

State	Bridge	Q5	Q6	Q7
			The technique requires some traffic control and depending on the number of lanes carried by the structure could produce minor to significant traffic disruption. At least one lane and the shoulder will need to be closed; therefore, if the bridge is narrow with a small number of lanes carrying two-way traffic the disruption could be considerable. This could last for several weeks if there are a large number of stays that need to be tested. The cost can run anywhere from \$50,000 to \$75,000 per bridge per test event depending on the size of the structure	department's experience should not be considered as a primary damping mechanism. The cross tie system that the department has employed has been effective in reducing the extreme vibration events, but vibrations of an amplitude that causes concern still occur. Texas is presently installing viscous damping systems of each of the cable stay bridges in the state. On the Fred Hartman Bridge these will be installed in conjunction with cross tie cables. It is hoped that this combination will effectively eliminate the occurrence and amplitude of any vibrations
Virginia	I-295 over James River (Varina–Enon Bridge)	yes	Laser-based force measurements were utilized in the initial in-depth inspection of this bridge in 1999. The cost incurred was approximately \$35,000 with minimum impact on traffic	Neoprene rings were installed on the Varina–Enon Bridge as the primary stay damping system. This is a relatively cost-effective system and appears to be performing satisfactorily on this bridge. We have experienced some difficulty in the installation and removal of these rings. Details of an alternate stay damping system utilizing shock absorbers have been included in the Manual for Inspection and Maintenance of the Varina–Enon Bridge
Washington	Gum Street—Kennewick, WA	yes	N/A	N/A
Washington	Thea–Foss Tacoma, WA	yes	N/A	N/A
Wisconsin	Sixth Street Viaduct, North Cable Stay	Not known—no previous experience with cable-stayed structure	City inspection forces are neither qualified nor equipped for non-destructive testing. Four single strands are to be removed (one at each pylon) for inspection for rust every 10 years starting in year 2014	no vibrations noted
Wisconsin	Sixth Street Viaduct,	Not known—no previous	City inspection forces	no vibrations noted

NCHRP SYNTHESIS TOPIC 35-07—INSPECTION AND MAINTENANCE OF BRIDGE STAY CABLE SYSTEMS

State	Bridge	Q5	Q6	Q7
	South Cable Stay	experience with cable-stayed structure	are neither qualified nor equipped for non-destructive testing. Four single strands are to be removed (one at each pylon) for inspection for rust every 10 years starting in year 2014	
Alberta/Calgary	Prince's Island (Pedestrian)	yes	no answer	The installation of cross cables have greatly reduced the cable vibration
Alberta/Calgary	Carburn Park (Pedestrian)	yes	no answer	The installation of cross cables have greatly reduced the cable vibration
Alberta/Calgary	McMahon (Pedestrian)	yes	no answer	The installation of cross cables have greatly reduced the cable vibration
Alberta/Calgary	Fox Hollow (Pedestrian)	yes	no answer	The installation of cross cables have greatly reduced the cable vibration
Alberta/Calgary	Stoney Trail (Pedestrian)	yes	no answer	The installation of cross cables have greatly reduced the cable vibration
British Columbia	Alex Fraser Bridge	yes	not used	Neoprene ring dampers alone do not prevent cable vibration
Manitoba/Winnipeg	Esplanade Riel	Not known—we require training and awareness in the near future to properly maintain the one new bridge we have	We do not yet have enough experience to respond to this question at this time. We are aware of all the techniques you mention above. Force measurements on selected MTE will be performed as part of the SHM system with the use of uniaxial accelerometers to determine frequency of the cable and relate back to force	We have yet to pass judgment on the effectiveness of the control measures. We specified the requirement for damping at the anchorages. The supplier choose to do this via neoprene rings
New Brunswick	Hawkshaw	yes	None of this testing done on any of the three structures. Probably there would be a significant cost to do these tests	See comments Question 4-12
New Brunswick	Longs Creek #1	yes	None of this testing done on any of the three structures. Probably there would be a significant cost to do these tests	See comments Question 4-12
New Brunswick	Nackawic River	yes	None of this testing done on any of the three structures. Probably there would be a significant cost to do these tests	See comments Question 4-12

NCHRP SYNTHESIS TOPIC 35-07—INSPECTION AND MAINTENANCE OF BRIDGE STAY CABLE SYSTEMS

State	Bridge	Q5	Q6	Q7
Quebec, Canada	Galipeault	yes	We have performed laser-based force on Galipeault Bridge	
Quebec, Canada	Papineau	yes	We have performed laser-based force on Galipeault Bridge	
Quebec, Canada	Price		Neoprene rings have reduced cable vibrations on the Price bridge (no. 3)	
	Freyssinet	<p>Yes—Freyssinet has installed its stay system on three projects. Bill Emerson Bridge over the Mississippi River at Cape Girardeau, MO; I-93 over the Charles River in Boston, MA; and Cooper River Replacement Bridge in Charleston, SC. The Cape Girardeau Bridge was required to be grouted by the Owner and Engineer. Freyssinet proposed ungrouted stays but this was unacceptable for reasons unknown. The thought was the Owner and Engineer did not want to be the first in U.S. to allow ungrouted stays. The Charles River was designed to use grouted stays, but Freyssinet was able to convince the Owner and Engineer that ungrouted stays were superior, mainly due to the improved inspectability and replaceability, but also to avoid the common problems associated with grouted cables (introduce moisture, increase local bending moments at the anchorages, more mass to dampen, potential damage to the HDPE stay pipe if high grouting pressures are used). Also, during grouting everything gets warm (or very hot if grouted during the summer in warm or even moderate climates). When colder winter temperatures arrive, the pipes develop very high-tensile stresses as the pipe tries to thermally contract, but is restrained since the grout has a much lower thermal coefficient of expansion and contraction. The cables on the Cooper River Bridge are state of the art</p>	<p>With ungrouted stays, individual strands may be detensioned, inspected, retensioned, or removed and/or replaced. Load cells may be left in place to monitor strands individually. Acoustic monitoring systems can be installed to detect wire breakage and determine the break locations very accurately</p>	<p>External helix placed on the surface of the stay pipes has been proven to eliminate rain–wind-induced cable vibrations. Freyssinet developed this on the Normandie Bridge in France. Freyssinet offered this on Cape Girardeau and Charles River projects and both sites elected to add external helix via a change order due the very real threat of serious rain–wind-induced vibrations and the high level of effectiveness offered by the external helix</p>

NCHRP SYNTHESIS TOPIC 35-07—INSPECTION AND MAINTENANCE OF BRIDGE STAY CABLE SYSTEMS

State	Bridge	Q5	Q6	Q7
		ungrouted stays with capacity to add approximately 5% strand in the future and the stays are fitted with engineered vibration suppression devices. Internal hydraulic and external hydraulic damping devices are being installed and provisions provide for the possible addition of cable ties (damping ropes) in the future on selected longer stays that have been identified as having the potential to experience parametric excitation		

NCHRP SYNTHESIS TOPIC 35-07—INSPECTION AND MAINTENANCE OF BRIDGE STAY CABLE SYSTEMS

Questions:

Q8 Please comment on the effectiveness of any sensor-based, long-term monitoring systems for stay cables that you may be familiar with. Examples include acoustic monitoring, vibration monitoring, force measurements, strain measurements, etc.

Q9 What would you recommend that the cable suppliers incorporate into their systems to make cables more accessible and inspectable?

Q10 Do you believe that an up-to-date resource such as a national database of information on stay cable inspection methods, repairs, and testing would be a useful tool?

Responses:

State	Bridge	Q8	Q9	Q10
Alabama	Cochrane Africatown	Check with A.G. Lichtenstein	Provide access on inside and outside of tower anchorage	not known
Alaska	Sitka Harbor Bridge, Sitka, Alaska	N/A	N/A	yes
Alaska	Captain William Moore Bridge, Skagway	N/A	N/A	yes
California	Sacramento River (Meridian)	Acoustic monitoring appears to have great value and promise. Would recommend that this technology be fully developed	Fiber optic strain gauges and redundant systems	yes
Delaware	Br. 1-902, SR-1 over the Chesapeake and Delaware Canal, St. Georges, New Castle County, Delaware	The current sensor-based, long-term monitoring system installed on the bridge is not operable and therefore comment cannot be made. The department is considering the addition of force measurement (deck-based laser method) to the list of inspection items required for the bridge	We would recommend the development of individual strand monitoring capabilities which encompass the strands from anchorage to anchorage	yes
Florida	Dame Point Bridge	none	Not familiar with this	yes
Georgia	Talmadge Memorial Bridge, Savannah	These are all effective, but they are generally expensive and have not been used on Georgia's bridges	For non-box bridges, an inspection traveler should be installed on the cable-stayed bridge. This should be done by the owner	yes
Georgia	Sidney Lanier Bridge, Brunswick	These are all effective, but they are generally expensive and have not been used on Georgia's bridges	For non-box bridges, an inspection traveler should be installed on the cable-stayed bridge. This should be done by the owner	yes
Illinois	Quincy Bayview Bridge at Quincy, IL	An acoustic monitoring system was installed (approximately a year and a half ago) on one-fourth of the stays of the Quincy Bayview Bridge. This was done due to concern over water in the cable	no answer	yes

NCHRP SYNTHESIS TOPIC 35-07—INSPECTION AND MAINTENANCE OF BRIDGE STAY CABLE SYSTEMS

State	Bridge	Q8	Q9	Q10
		anchorages and to evaluate the technology. The system appears to be functioning properly and so far has provided information on one "event" that has been classified as a wire break		
Illinois	Clark Bridge at Alton, IL	An acoustic monitoring system was installed (approximately a year and a half ago) on one-fourth of the stays of the Quincy Bayview Bridge. This was done due to concern over water in the cable anchorages and to evaluate the technology. The system appears to be functioning properly and so far has provided information on one "event" that has been classified as a wire break	no answer	yes
Indiana	46-03-7495 EBL	Have not used any yet.	??	yes
Indiana	I65-68-7910	Have not used any yet.	??	yes
Iowa	Burlington, IA	Have not had experience with long-term monitoring	no answer	yes
Kentucky	William Natcher Bridge, Owensboro, KY	There are two problems on the monitoring systems. First, who will analyze the large amount of data collected? Second, how long will the sensors and the computer system last? We are talking about 100-year life span. The reality is that the monitoring system will fail or become obsolete within approximately 10 years when the bridge is not expected to have any problems. (PB)	It does not seem possible that the cable suppliers can do any more. (PB)	yes—the resource does not exist so far. We (Parsons Brinkerhoff) are developing them right now. (PB)
Kentucky	William H. Harsha Bridge, Maysville, KY	There are two problems on the monitoring systems. First, who will analyze the large amount of data collected? Second, how long will the sensors and the computer system last? We are talking about 100-year life span. The reality is that the monitoring system will fail or become obsolete within	It does not seem possible that the cable suppliers can do any more. (PB)	yes—the resource does not exist so far. We (Parsons Brinkerhoff) are developing them right now. (PB)

NCHRP SYNTHESIS TOPIC 35-07—INSPECTION AND MAINTENANCE OF BRIDGE STAY CABLE SYSTEMS

State	Bridge	Q8	Q9	Q10
		approximately 10 years when the bridge is not expected to have any problems. (PB)		
Louisiana	Mississippi River Bridge at Luling, LA	Vibration monitoring has been ongoing at Luling for 20 years in anticipation of a hurricane striking the bridge—no significant long duration winds have occurred	I like the idea of hermetically sealed, ungrouted cables with fiber optic sensors throughout or exposed wire that can be directly inspected	yes
Mississippi		No comment/not known	No comment/no comment	Not known/yes
Massachusetts	Leonard P. Zakim Bunker Hill Bridge, Boston, MA	none	Transparent outer pipe, eliminate grout	yes
Missouri	Bill Emerson Memorial Bridge, Cape Girardeau	MoDOT has no related experience	Perhaps a permanent load cell that would permit real-time readings of cable forces at any time during the life of the bridge	yes
Ohio	Maumee River Bridge, Toledo	no answer	Access is a very sharp two-edged sword. If you can more easily access the cable, so can corrosive elements (not to mention potential terrorist/security considerations)	Not known—while information can be useful, it can also be misinterpreted. The best resource is direct contact with those who have hands-on knowledge related to the specific area that an individual may be making inquiries
South Carolina	Cooper River Bridge	none	Include a maintenance manual with clear instructions for both specific wires or full cables	yes
Texas	Veterans Memorial Bridge	The department has installed an acoustic monitoring system to identify possible wire breaks at the Fred Hartman Bridge. The system seems to work well and has identified several possible wire breaks. Prior to its installation, the system was tested on a cable mock-up at the Ferguson Structural Lab of the University of Texas at Austin, where research is underway to determine the effects of stay cable vibrations on the fatigue life of the cables. This allowed the department to test the monitoring system to see how accurately it could identify occurrence and location of wire breaks since numerous wire breaks	Current grouted and sheathed systems do not allow for visual inspection. New stay systems (perhaps ungrouted, unsheathed systems consisting of bare corrosion-resistant tension members) need to be developed that allow for inspection of the entire stay length. Research is also needed to develop rapid, economical evaluation (NDE) methods to determine conditions of stay cables	yes

NCHRP SYNTHESIS TOPIC 35-07—INSPECTION AND MAINTENANCE OF BRIDGE STAY CABLE SYSTEMS

State	Bridge	Q8	Q9	Q10
		were generated. The correlation between the monitoring system results and the autopsied cables was very good		
Texas	Fred Hartman Bridge	The department has installed an acoustic monitoring system to identify possible wire breaks at the Fred Hartman Bridge. The system seems to work well and has identified several possible wire breaks. Prior to its installation, the system was tested on a cable mock-up at the Ferguson Structural Lab of the University of Texas at Austin, where research is underway to determine the effects of stay cable vibrations on the fatigue life of the cables. This allowed the department to test the monitoring system to see how accurately it could identify occurrence and location of wire breaks since numerous wire breaks were generated. The correlation between the monitoring system results and the autopsied cables was very good	Current grouted and sheathed systems do not allow for visual inspection. New stay systems (perhaps ungrouted, unsheathed systems consisting of bare corrosion resistant tension members) need to be developed that allow for inspection of the entire stay length. Research is also needed to develop rapid, economical evaluation (NDE) methods to determine conditions of stay cables	yes
Virginia	I-295 over James River (Varina–Enon Bridge)	no comments	no comments	yes
Washington	Gum Street—Kennewick, WA	N/A	unknown	yes
Washington	Thea–Foss Tacoma, WA	N/A	unknown	yes
Wisconsin	Sixth Street Viaduct, North Cable Stay	not applicable	no answer	yes
Wisconsin	Sixth Street Viaduct, South Cable Stay	not applicable	no answer	yes
Alberta/Calgary	Prince’s Island (Pedestrian)	Have not used vibration monitoring on a long-term basis. Has only been used for short durations to determine frequency and magnitude, etc.	no answer	yes
Alberta/Calgary	Carburn Park (Pedestrian)	Have not used vibration monitoring on a long-term basis. Has only been used for short durations to determine frequency and magnitude, etc.	no answer	yes
Alberta/Calgary	McMahon (Pedestrian)	Have not used vibration monitoring on a long-term basis. Has only	no answer	yes

NCHRP SYNTHESIS TOPIC 35-07—INSPECTION AND MAINTENANCE OF BRIDGE STAY CABLE SYSTEMS

State	Bridge	Q8	Q9	Q10
		been used for short durations to determine frequency and magnitude, etc.		
Alberta/Calgary	Fox Hollow (Pedestrian)	Have not used vibration monitoring on a long-term basis. Has only been used for short durations to determine frequency and magnitude, etc.	no answer	yes
Alberta/Calgary	Stoney Trail (Pedestrian)	Have not used vibration monitoring on a long-term basis. Has only been used for short durations to determine frequency and magnitude, etc.	no answer	yes
British Columbia	Alex Fraser Bridge	Acoustic monitoring may be cost-effective for older structures. For new structures, cost of monitoring outweighs benefits, and may be compromised by other noise (rehab, banging, etc.) on the structure	Our cables are reasonably accessible, inspectable. Possibly a closeable drain at the lower end of the cable to allow visual inspection, sample collection, testing for corrosion product of any water in the cable sheaths	yes
Manitoba/Winnipeg	Esplanade Riel	Not enough experience to comment at this time	Different corrosion protection system at the anchorages that permits easier visual inspection. Removable sections of the HDPE and Vandal Tubes would make it easier to inspect strands near the anchorages	yes
New Brunswick	Hawkshaw	Monitoring of deflection of bridge by student at Nackawic	no answer	yes
New Brunswick	Longs Creek #1	Monitoring of deflection of bridge by student at Nackawic	no answer	yes
New Brunswick	Nackawic River	Monitoring of deflection of bridge by student at Nackawic	no answer	yes
Quebec, Canada	Galipeault	No long-term monitoring on our stay cable bridges at the present time	no answer	yes
Quebec, Canada	Papineau	No long-term monitoring on our stay cable bridges at the present time	no answer	yes
Quebec, Canada	Price			
	Freyssinet	We believe acoustical monitoring is an effective method to record wire failures. Permanent load cells are good for monitoring loads, especially with unbonded monostrands when it can be established that the load	Ability to detension, inspect, and retension individual strands Ability to detension, remove, and replace individual strands. Ability to add strands to each cable or cable group (avg. 5%)	yes

***NCHRP SYNTHESIS TOPIC 35-07—INSPECTION AND MAINTENANCE OF BRIDGE STAY
CABLE SYSTEMS***

State	Bridge	Q8	Q9	Q10
		is equal in all individual strands within reasonable tolerances such that by monitoring one strand, the load in cable is known		

NCHRP SYNTHESIS TOPIC 35-07—INSPECTION AND MAINTENANCE OF BRIDGE STAY CABLE SYSTEMS

Questions:

Q11 What do you see as the single most important problem in stay cable maintenance?

Q12 Please comment on any other methods for inspections, testing, monitoring, and repair of stay cable (including conventional methods) that you have found beneficial and are not listed above.

Additional Comments?

Responses:

State	Bridge	Q11	Q12	Additional Comments
Alabama	Cochrane Africatown	Stay anchors. (Access and rain-wind-induced oscillation)	no answer	
Alaska	Sitka Harbor Bridge, Sitka, Alaska	Access to upper cable anchorage	N/A	no answer
Alaska	Captain William Moore Bridge, Skagway	Access to upper cable anchorage	N/A	no answer
California	Sacramento River (Meridian)	Inspection and condition evaluation of anchorages	Engineering judgment and experience seem to prevail in determining appropriate inspection and maintenance strategies	
Delaware	Br. 1-902, SR-1 over the Chesapeake and Delaware Canal, St. Georges, New Castle County, Delaware	Effective corrosion barriers that do not interfere with the ability to adequately inspect and assess the health of the cable stay system on a regular interval and within practical means		
Florida	Dame Point Bridge	Accessibility for inspection and maintenance	Man-lift truck	
Georgia	Talmadge Memorial Bridge, Savannah	Access to the cable anchorages	Television endoscope-type cameras for access to guide pipes at bridge deck level is helpful	
Georgia	Sidney Lanier Bridge, Brunswick	Access to the cable anchorages	Television endoscope-type cameras for access to guide pipes at bridge deck level is helpful	
Illinois	Quincy Bayview Bridge at Quincy, IL	Uncertainty of cable condition and anchorages	no answer	
Illinois	Clark Bridge at Alton, IL	Uncertainty of cable condition and anchorages	no answer	
Indiana	46-03-7495 EBL	Inspection, access, testing, cost	no answer	
Indiana	I65-68-7910	Inspection, access, testing, cost	no answer	
Iowa	Burlington, IA	The inability to inspect the elements inside the cable and the anchorage areas	no answer	
Kentucky	William Natcher Bridge, Owensboro, KY	Inspecting the cable anchors. (PB) Inspecting grout-filled cables. (DKD)	none	Comments followed by (DKD) were made by Darrell Dudgeon of KYTC. Comments followed by (PB) were made by Ruchu Hsu,

NCHRP SYNTHESIS TOPIC 35-07—INSPECTION AND MAINTENANCE OF BRIDGE STAY CABLE SYSTEMS

State	Bridge	Q11	Q12	Additional Comments
				P.E. of Parsons Brinkerhoff Quade and Douglas, Inc. Consulting Engineers who was the lead design engineer for the Owensboro Bridge
Kentucky	William H. Harsha Bridge, Maysville, KY	Inspecting the cable anchors. (PB) Inspecting grout-filled cables. (DKD)	none	Comments followed by (DKD) were made by Darrell Dudgeon of KYTC. Comments followed by (PB) were made by Ruchu Hsu, P.E. of Parsons Brinkerhoff Quade and Douglas, Inc. Consulting Engineers who was the lead design engineer for the Owensboro Bridge
Louisiana	Mississippi River Bridge at Luling, LA	The hidden nature of the system	no answer	no answer
Mississippi		No comment/we do not have enough experience in this area to comment	N/A and N/A	
Massachusetts	Leonard P. Zakim Bunker Hill Bridge, Boston, MA	Access for inspection	Stay cable anchorage design should allow for accessibility for inspection. Inspection, maintenance, and replacement should be addressed during design	no answer
Missouri	Bill Emerson Memorial Bridge, Cape Girardeau	The integrity of the stays. Grouted cables are impossible to inspect with a non-destructive technique (i.e., one that does not require removal of sheathing and grout) thus, it is impossible to identify corrosion problems early	MoDOT has no related experience	
Ohio	Maumee River Bridge, Toledo	The largest "problem" with stay cables is that they are widely perceived as "a problem" rather than just another bridge member with specific needs and characteristics. Stay cables have been placed unnecessarily "on a pedestal." While they are a very important bridge member, in current designs they are highly redundant, overtested, and (relatively) easily replaced. There is no other major bridge member that fits into all three of these categories. Let's not	no answer	no answer

NCHRP SYNTHESIS TOPIC 35-07—INSPECTION AND MAINTENANCE OF BRIDGE STAY CABLE SYSTEMS

State	Bridge	Q11	Q12	Additional Comments
		promote the feeling that Stays are “a maintenance problem”		
South Carolina	Cooper River Bridge	Provide end caps that are easily removed and fully protected against corrosion	no answer	
Texas	Veterans Memorial Bridge	Ability to determine the effectiveness and remaining life of corrosion protection systems for main tension elements. The configuration and construction techniques make evaluation and inspection using non-destructive techniques almost impossible	no answer	
Texas	Fred Hartman Bridge	Ability to determine the effectiveness and remaining life of corrosion protection systems for main tension elements. The configuration and construction techniques make evaluation and inspection using non-destructive techniques almost impossible	no answer	
Virginia	I-295 over James River (Varina–Enon Bridge)	Lack of familiarity with this type of construction by the department's staff which requires assistance from the consultant community in the inspection of these elements	no answer	
Washington	Gum Street—Kennewick, WA	none yet	N/A	
Washington	Thea–Foss Tacoma, WA	none yet	N/A	
Wisconsin	Sixth Street Viaduct, North Cable Stay	Cannot inspect cables without pulling strand every 10 years	Four strands (one at each pylon) will be removed every 10 years starting in 2014 to check for corrosion/rusting	
Wisconsin	Sixth Street Viaduct, South Cable Stay	Cannot inspect cables without pulling strand every 10 years	Four strands (one at each pylon) will be removed every 10 years starting in 2014 to check for corrosion/rusting	
Alberta/Calgary	Prince's Island (Pedestrian)	Access for inspection and actual testing	no answer	The five bridges identified are all pedestrian structures. Three over water and two over roadways
Alberta/Calgary	Carburn Park (Pedestrian)	Access for inspection and actual testing	no answer	The five bridges identified are all pedestrian structures. Three over water and two over roadways
Alberta/Calgary	McMahon (Pedestrian)	Access for inspection and actual testing	no answer	The five bridges identified are all

NCHRP SYNTHESIS TOPIC 35-07—INSPECTION AND MAINTENANCE OF BRIDGE STAY CABLE SYSTEMS

State	Bridge	Q11	Q12	Additional Comments
				pedestrian structures. Three over water and two over roadways
Alberta/Calgary	Fox Hollow (Pedestrian)	Access for inspection and actual testing	no answer	The five bridges identified are all pedestrian structures. Three over water and two over roadways
Alberta/Calgary	Stoney Trail (Pedestrian)	Access for inspection and actual testing	no answer	The five bridges identified are all pedestrian structures. Three over water and two over roadways
British Columbia	Alex Fraser Bridge	Detecting corrosion in cables, maintenance of sheaths and boots	no comment	Have had leakage of wax blocking compound at bottom anchorages during hot weather
Manitoba/Winnipeg	Esplanade Riel	Corrosion at the anchorages	no answer	
New Brunswick	Hawkshaw	Migration of water into cable strands	no answer	
New Brunswick	Longs Creek #1	Migration of water into cable strands	no answer	
New Brunswick	Nackawic River	Migration of water into cable strands	no answer	
Quebec, Canada	Galipeault	Fatigue	no answer	We have had a serious problem on Galipeault bridge no. 1—failure of an anchorage plate at one abutment (corrosion and fatigue failure). Emergency repairs were performed
Quebec, Canada	Papineau	Fatigue	no answer	We have had a serious problem on Galipeault bridge no. 1—failure of an anchorage plate at one abutment (corrosion and fatigue failure). Emergency repairs were performed
Quebec, Canada	Price			We also had a failure of an anchorage plate on Price bridge (no. 3) during the 1988 Saguenay earthquake (ML = 6.0). It was the first documented structural damage to a steel bridge caused by an earthquake in Canada
	Freyssinet	Inspectability in the anchorage area	no answer	

Abbreviations used without definitions in TRB publications:

AASHO	American Association of State Highway Officials
AASHTO	American Association of State Highway and Transportation Officials
ADA	Americans with Disabilities Act
APTA	American Public Transportation Association
ASCE	American Society of Civil Engineers
ASME	American Society of Mechanical Engineers
ASTM	American Society for Testing and Materials
ATA	American Trucking Associations
CTAA	Community Transportation Association of America
CTBSSP	Commercial Truck and Bus Safety Synthesis Program
DHS	Department of Homeland Security
DOE	Department of Energy
EPA	Environmental Protection Agency
FAA	Federal Aviation Administration
FHWA	Federal Highway Administration
FMCSA	Federal Motor Carrier Safety Administration
FRA	Federal Railroad Administration
FTA	Federal Transit Administration
IEEE	Institute of Electrical and Electronics Engineers
ISTEA	Intermodal Surface Transportation Efficiency Act of 1991
ITE	Institute of Transportation Engineers
NASA	National Aeronautics and Space Administration
NCHRP	National Cooperative Highway Research Program
NCTRP	National Cooperative Transit Research and Development Program
NHTSA	National Highway Traffic Safety Administration
NTSB	National Transportation Safety Board
SAE	Society of Automotive Engineers
SAFETEA-LU	Safe, Accountable, Flexible, Efficient Transportation Equity Act: A Legacy for Users (2005)
TCRP	Transit Cooperative Research Program
TEA-21	Transportation Equity Act for the 21st Century (1998)
TRB	Transportation Research Board
TSA	Transportation Security Administration
U.S.DOT	United States Department of Transportation