

Default Values for Highway Capacity and Level of Service Analyses

DETAILS

0 pages | | PAPERBACK

ISBN 978-0-309-43229-0 | DOI 10.17226/22061

AUTHORS

BUY THIS BOOK

FIND RELATED TITLES

Visit the National Academies Press at NAP.edu and login or register to get:

- Access to free PDF downloads of thousands of scientific reports
- 10% off the price of print titles
- Email or social media notifications of new titles related to your interests
- Special offers and discounts



Distribution, posting, or copying of this PDF is strictly prohibited without written permission of the National Academies Press. (Request Permission) Unless otherwise indicated, all materials in this PDF are copyrighted by the National Academy of Sciences.

NCHRP REPORT 599

**Default Values for
Highway Capacity and
Level of Service Analyses**

John D. Zegeer

Mark Vandehey

Miranda Blogg

Khang Nguyen

Michael Ereti

KITTELSON & ASSOCIATES, INC.

Fort Lauderdale, FL

Subject Areas

Planning and Administration

Research sponsored by the American Association of State Highway and Transportation Officials
in cooperation with the Federal Highway Administration

TRANSPORTATION RESEARCH BOARD

WASHINGTON, D.C.

2008

www.TRB.org

NATIONAL COOPERATIVE HIGHWAY RESEARCH PROGRAM

Systematic, well-designed research provides the most effective approach to the solution of many problems facing highway administrators and engineers. Often, highway problems are of local interest and can best be studied by highway departments individually or in cooperation with their state universities and others. However, the accelerating growth of highway transportation develops increasingly complex problems of wide interest to highway authorities. These problems are best studied through a coordinated program of cooperative research.

In recognition of these needs, the highway administrators of the American Association of State Highway and Transportation Officials initiated in 1962 an objective national highway research program employing modern scientific techniques. This program is supported on a continuing basis by funds from participating member states of the Association and it receives the full cooperation and support of the Federal Highway Administration, United States Department of Transportation.

The Transportation Research Board of the National Academies was requested by the Association to administer the research program because of the Board's recognized objectivity and understanding of modern research practices. The Board is uniquely suited for this purpose as it maintains an extensive committee structure from which authorities on any highway transportation subject may be drawn; it possesses avenues of communications and cooperation with federal, state and local governmental agencies, universities, and industry; its relationship to the National Research Council is an insurance of objectivity; it maintains a full-time research correlation staff of specialists in highway transportation matters to bring the findings of research directly to those who are in a position to use them.

The program is developed on the basis of research needs identified by chief administrators of the highway and transportation departments and by committees of AASHTO. Each year, specific areas of research needs to be included in the program are proposed to the National Research Council and the Board by the American Association of State Highway and Transportation Officials. Research projects to fulfill these needs are defined by the Board, and qualified research agencies are selected from those that have submitted proposals. Administration and surveillance of research contracts are the responsibilities of the National Research Council and the Transportation Research Board.

The needs for highway research are many, and the National Cooperative Highway Research Program can make significant contributions to the solution of highway transportation problems of mutual concern to many responsible groups. The program, however, is intended to complement rather than to substitute for or duplicate other highway research programs.

NCHRP REPORT 599

Project 3-82
ISSN 0077-5614
ISBN: 978-0-309-09931-8
Library of Congress Control Number 2008925081

© 2008 Transportation Research Board

COPYRIGHT PERMISSION

Authors herein are responsible for the authenticity of their materials and for obtaining written permissions from publishers or persons who own the copyright to any previously published or copyrighted material used herein.

Cooperative Research Programs (CRP) grants permission to reproduce material in this publication for classroom and not-for-profit purposes. Permission is given with the understanding that none of the material will be used to imply TRB, AASHTO, FAA, FHWA, FMCSA, FTA, or Transit Development Corporation endorsement of a particular product, method, or practice. It is expected that those reproducing the material in this document for educational and not-for-profit uses will give appropriate acknowledgment of the source of any reprinted or reproduced material. For other uses of the material, request permission from CRP.

NOTICE

The project that is the subject of this report was a part of the National Cooperative Highway Research Program conducted by the Transportation Research Board with the approval of the Governing Board of the National Research Council. Such approval reflects the Governing Board's judgment that the program concerned is of national importance and appropriate with respect to both the purposes and resources of the National Research Council.

The members of the technical committee selected to monitor this project and to review this report were chosen for recognized scholarly competence and with due consideration for the balance of disciplines appropriate to the project. The opinions and conclusions expressed or implied are those of the research agency that performed the research, and, while they have been accepted as appropriate by the technical committee, they are not necessarily those of the Transportation Research Board, the National Research Council, the American Association of State Highway and Transportation Officials, or the Federal Highway Administration, U.S. Department of Transportation.

Each report is reviewed and accepted for publication by the technical committee according to procedures established and monitored by the Transportation Research Board Executive Committee and the Governing Board of the National Research Council.

The Transportation Research Board of the National Academies, the National Research Council, the Federal Highway Administration, the American Association of State Highway and Transportation Officials, and the individual states participating in the National Cooperative Highway Research Program do not endorse products or manufacturers. Trade or manufacturers' names appear herein solely because they are considered essential to the object of this report.

Published reports of the

NATIONAL COOPERATIVE HIGHWAY RESEARCH PROGRAM

are available from:

Transportation Research Board
Business Office
500 Fifth Street, NW
Washington, DC 20001

and can be ordered through the Internet at:

<http://www.national-academies.org/trb/bookstore>

Printed in the United States of America

THE NATIONAL ACADEMIES

Advisers to the Nation on Science, Engineering, and Medicine

The **National Academy of Sciences** is a private, nonprofit, self-perpetuating society of distinguished scholars engaged in scientific and engineering research, dedicated to the furtherance of science and technology and to their use for the general welfare. On the authority of the charter granted to it by the Congress in 1863, the Academy has a mandate that requires it to advise the federal government on scientific and technical matters. Dr. Ralph J. Cicerone is president of the National Academy of Sciences.

The **National Academy of Engineering** was established in 1964, under the charter of the National Academy of Sciences, as a parallel organization of outstanding engineers. It is autonomous in its administration and in the selection of its members, sharing with the National Academy of Sciences the responsibility for advising the federal government. The National Academy of Engineering also sponsors engineering programs aimed at meeting national needs, encourages education and research, and recognizes the superior achievements of engineers. Dr. Charles M. Vest is president of the National Academy of Engineering.

The **Institute of Medicine** was established in 1970 by the National Academy of Sciences to secure the services of eminent members of appropriate professions in the examination of policy matters pertaining to the health of the public. The Institute acts under the responsibility given to the National Academy of Sciences by its congressional charter to be an adviser to the federal government and, on its own initiative, to identify issues of medical care, research, and education. Dr. Harvey V. Fineberg is president of the Institute of Medicine.

The **National Research Council** was organized by the National Academy of Sciences in 1916 to associate the broad community of science and technology with the Academy's purposes of furthering knowledge and advising the federal government. Functioning in accordance with general policies determined by the Academy, the Council has become the principal operating agency of both the National Academy of Sciences and the National Academy of Engineering in providing services to the government, the public, and the scientific and engineering communities. The Council is administered jointly by both the Academies and the Institute of Medicine. Dr. Ralph J. Cicerone and Dr. Charles M. Vest are chair and vice chair, respectively, of the National Research Council.

The **Transportation Research Board** is one of six major divisions of the National Research Council. The mission of the Transportation Research Board is to provide leadership in transportation innovation and progress through research and information exchange, conducted within a setting that is objective, interdisciplinary, and multimodal. The Board's varied activities annually engage about 7,000 engineers, scientists, and other transportation researchers and practitioners from the public and private sectors and academia, all of whom contribute their expertise in the public interest. The program is supported by state transportation departments, federal agencies including the component administrations of the U.S. Department of Transportation, and other organizations and individuals interested in the development of transportation. www.TRB.org

www.national-academies.org

COOPERATIVE RESEARCH PROGRAMS

CRP STAFF FOR NCHRP REPORT 599

Christopher W. Jenks, *Director, Cooperative Research Programs*
Crawford F. Jencks, *Deputy Director, Cooperative Research Programs*
B. Ray Derr, *Senior Program Officer*
Eileen P. Delaney, *Director of Publications*
Kami Cabral, *Editor*

NCHRP PROJECT 3-82

Field of Traffic—Area of Operations and Control

Robert W. Bryson, *City of Milwaukee, Milwaukee, WI (Chair)*
Martin Guttenplan, *Florida DOT, Tallahassee, FL*
Montasir M. Abbas, *Virginia Polytechnic Institute and State University, Blacksburg, VA*
Thomas W. “Bill” Brockenbrough, Jr., *Delaware DOT, Dover, DE*
F. Thomas Creasey, *American Consulting Engineers, PLC, Lexington, KY*
Jeffery L. Memmott, *Bureau of Transportation Statistics, Washington, DC*
Narasimha Murthy, *Murthy Transportation Consultants, Inc., Fullerton, CA*
Douglas Norval, *Oregon DOT, Salem, OR*
Roger L. Russell, *Charleston, WV*
Zong Z. Tian, *University of Nevada - Reno, Reno, NV*
John Halkias, *FHWA Liaison*
Richard A. Cunard, *TRB Liaison*

AUTHOR ACKNOWLEDGMENTS

The Highway Capacity Manual Default Value Guidebook was developed under NCHRP Project 3-82. The NCHRP Project 3-82 team consisted of Kittelson & Associates, Inc. (prime contractor), assisted by Dr. James Bonneson (Texas Transportation Institute) and Dr. Fred Hall (McMaster University).

John D. Zegeer, P.E., PTOE, Senior Principal, Kittelson & Associates, Inc., was the principal investigator. Additional Kittelson & Associates, Inc., staff who played key roles in the development of this Guidebook included Miranda Blogg, Khang Nguyen, Michael Ereti, and Mark Vandehey. Additional assistance in the data summary and analysis activities for various input parameters was provided by other Kittelson staff, including Cade Braud, Joey Bansen, Justin Bansen, Thuha Lyew, Gorken Mimioglu, Alek Pochowski, and Ning Zou. Terry Raddeman provided GIS graphical support and analysis of metropolitan area populations. Beverley King provided word processing and editorial assistance.

Finally, the project team would like to express its appreciation for the dedicated work of the NCHRP Project 3-82 panel. The majority of the panel members have been involved in the review of interim materials and oversight of the findings throughout the project. The panel provided many thoughtful comments that have helped shape the current form of the Guidebook. The guidance provided by the NCHRP Program Officer, B. Ray Derr, is also greatly appreciated.



FOREWORD

By **B. Ray Derr**

Staff Officer

Transportation Research Board

Based on the assembly of an extensive set of field data from across the United States, this report presents valuable information on the appropriate selection of default values when analyzing highway capacity and level of service. The report will be useful to planners, geometric designers, and traffic engineers who do not have ready access to field data for an analysis. The report also describes how to prepare service volume tables, which can be a useful sketch planning technique.

The Year 2000 Highway Capacity Manual (HCM 2000) is the most extensively referenced document on highway capacity and quality-of-service computations in the United States. While the HCM 2000 focuses on providing state-of-the-art methodologies for operational analyses, it is also used in planning and preliminary engineering applications.

To assist engineers and planners in applying HCM methodologies, the HCM 2000 includes default values for many of the more difficult-to-obtain input parameters and variables. The HCM 2000 states: “A default value is a representative value that may be appropriate in the absence of local data.” As a result of insufficient field data, the HCM 2000 recommends only a single default value for many key data items, inadequately reflecting the variety of traffic and facility conditions across the United States. Because of limited resources or inexperience, analysts often use these default values inappropriately.

Under NCHRP Project 3-82, Kittelson & Associates, Inc., and their subcontractors reviewed all of the input values in the HCM to determine how sensitive the analysis methodologies are to them and the difficulty of obtaining non-default input values. They then assembled field data from various sources on the critical values. A statistical analysis of the field data was performed to develop guidance on the most appropriate default values to use. These recommended default values could be used in place of the default values provided in HCM 2000.



CONTENTS

1	Summary
1	Purpose of the Guidebook
2	Findings
3	Recommendations
9	Use of Service Volume Tables
11	Chapter 1 Introduction
13	Chapter 2 Current Planning Practices
13	History of HCM 2000
14	HCM 2000 Guidance on the Use of Default Values
17	HCM Definitions
18	Inventory of Default Values
30	User Survey Results
31	Chapter 3 Recommended Default Values
31	Defining Default Values by Category
34	Data Sources and Calculation Methodology
35	%HV for Uninterrupted Flow Facilities
37	PHFs for Uninterrupted Flow Facilities
43	%HV for Interrupted Flow Facilities
47	PHFs for Interrupted Flow Facilities
51	Base Saturation Flow Rates for Signalized Intersections
53	Lane Utilization for Through Lanes at Signalized Intersections
55	Chapter 4 Guidance for Selecting Defaults
55	Pedestrian Walking Speeds and Start-up Times at Signalized Intersections
58	Interchange Ramp Terminals
62	Driver Population Factors on Freeways
65	Signal Density on Urban Streets
66	Free-Flow Speed on Urban Streets
73	Saturation Flow Rates and Lane Utilization Factors for Dual and Triple Left-Turn Lanes
77	Chapter 5 Guidance for Preparing Service Volume Tables
77	Sample Service Volume Tables
79	Sensitivity Analysis
83	Appendix A Sensitivity Analysis
119	Appendix B Lane Utilization Adjustment Factors for Interchange Ramp Terminals

Default Values for Highway Capacity and Level of Service Analyses

The Highway Capacity Manual (HCM) is the authoritative source providing state-of-the-art methodologies for evaluating highway, transit, bicycle, and pedestrian facilities at both the operational and planning levels. The methodologies that are provided in the HCM require input parameters that depend on, in many cases, detailed site-specific data.

An input parameter is a variable that is included in an equation because it has an influence on the dependent variable and its value is likely to vary significantly over the range of possible equation applications. Input parameters can be measured in the field or estimated using approximation techniques. Default values are sometimes used to represent input parameters because these input parameters tend to be difficult to measure (or estimate).

Default values may also be used for input parameters when those variables have minimal impact on the outcome of the results. Thus, a default value is a representative value that may be used in place of actual field data for estimating an input parameter. Default values are typically used for planning applications. This occurs because many planning analyses are conducted for future conditions where the geometric and operational characteristics of the facility are not known. Default values are also frequently used for operational analysis when field data have not been collected.

Purpose of the Guidebook

Many of the HCM default values are not always applicable to given local conditions. This is true because the default values are based on limited data collected over several years or they are not provided. Prior to this project effort, no nationwide research effort had been conducted to assemble field measurements to determine if the default values contained in the HCM represent typical conditions.

This research effort was conducted to assemble field measurements for the relevant input variables. As a result of this effort, this Guidebook was prepared to assist users of the HCM in the selection of default values for various HCM applications. First, appropriate default values that should be used for inputs to HCM analyses were identified. Then, a guide to select default values for various applications was developed.

This Guidebook describes the use of the current default values contained in the HCM and their application in planning and operations analysis practices (Chapter 2). Changes to existing default values in the HCM are recommended based on the analysis of an extensive set of data that was collected throughout the United States (Chapter 3). When field data were not available, guidance was developed (based on research results) to assist the analyst in estimating appropriate default values (Chapter 4). Finally, guidance is provided on how to develop

service volume tables for freeways and urban streets using a range of default values (Chapter 5). In Appendix A, the sensitivity of the various default values on the analysis results is described by showing the impact on the service measures for each HCM methodology where default values are provided.

Findings

A detailed investigation of default values that are provided in HCM 2000 was conducted. The results of this investigation led to findings that are described in the following three categories:

- Existing HCM Guidance in the Use of Default Values
- Inventory of Existing Default Values
- Sensitivity of Default Values

Existing HCM Guidance in the Use of Default Values

Guidance on the use of default values is provided in Chapter 9, Analytical Procedures Overview, of HCM 2000. A portion of that guidance is provided below.

“The analyst should observe the following suggestions when generating inputs to the analytical procedures.

- If the input variable can be observed in the field, measure it in the field.
- In performing a planning application for a facility not yet built, measure a similar facility in the area that has conditions similar to those of the proposed facility.
- If neither of the first two sources is available, rely on local policy or typical local/state values.
- If none of the above sources is available, default values provided in Part II (Chapters 10 through 14) of this manual may be used.”

Inventory of Existing Default Values

In Part II of HCM 2000, there are four chapters (Chapters 10 through 13) that contain a total of 63 default values. These default values are used in eight methodologies. These methodologies (and the number of default values that are provided for each of them) are provided below:

- Urban Streets (2)
- Signalized Intersections (19)
- Pedestrians (5)
- Bicycles (3)
- Multilane Highways (9)
- Two-Lane Highways (11)
- Basic Freeway Segments (8)
- Ramps and Ramp Junctions (6)

In addition, there are default values provided for three general traffic characteristics in Chapter 9 of HCM 2000. Table 3 in Chapter 2 of this Guidebook lists the default value for each of these input parameters and identifies the original source that served as the basis for each of them.

Default values are not provided for the following methodologies:

- Two-way Stop-Controlled (TWSC) Intersections
- All-way Stop-Controlled (AWSC) Intersections
- Interchange Ramp Terminals

- Freeway Facilities
- Freeway Weaving
- Transit (default values for this methodology are contained in the Transit Capacity and Quality of Service Manual [TCQSM])

Sensitivity of Default Values

A sensitivity analysis was conducted for all 63 input parameters where HCM 2000 suggests default values. The intent of this analysis was to determine which input parameters deserved further study based on the relative change in the relevant service measure due to the change in the value of the input parameter. Those input parameters that had a high degree of impact on the relevant service measures were recommended for further study. To facilitate the ranking of the input parameters, the following three thresholds were established.

- The input parameter has a low degree of sensitivity if varying the input parameter value changes the service measure by 0 to 10%.
- The input parameter has a moderate degree of sensitivity if varying the input parameter value changes the service measure by 10 to 20%.
- The input parameter has a high degree of sensitivity if varying the input parameter changes the service measure by more than 20%.

The following 19 input parameters had a high degree of sensitivity in influencing the service measure results:

- Urban Streets (1)—signal density
- Signalized Intersections (7)—peak-hour factor (PHF), length of analysis period, arrival type, adjusted saturation flow rate, lane width, percent heavy vehicle (%HV), lane utilization
- Pedestrians (4)—effective sidewalk width, street corner radius, pedestrian walking speed, pedestrian start-up time
- Bicycle paths (2)—PHF, bicycle speed
- Multilane highways (2)—base free flow speed, PHF
- Two-Lane Highways (0)—none
- Basic Freeway Segments (3)—driver population factor (DPF), grade, PHF
- Ramps and Ramp Junctions (0)—none

Recommendations

In general, input parameters that describe the facility type, area type, terrain type, and geometric configuration (such as lane width, segment length, and interchange spacing) are readily available to the analyst. Default values should not be used for these input parameters. Default values for the following input parameters should be developed based on existing HCM guidance:

- Signalized Intersections—length of analysis period, arrival type
- Bicycle Paths—PHF, bicycle speed
- Multilane Highways—basic free-flow speed (FFS)

The following input parameters should be measured in the field or on plan drawings:

- Signalized Intersections—lane width
- Pedestrians—sidewalk width, street corner radius
- Two-Lane Highways—length of passing lanes
- Basic Freeway Segments—specific grade or general terrain

The remaining input parameters that are highly sensitive can be broken into two categories. The first category is where data can be obtained and the default value may be confirmed, updated, or defined further. The second category is where data is not readily available; however, guidance regarding the selection of an appropriate default value can be provided based on research.

Recommended Default Values Based on Data

For the first category of input parameters, data was collected throughout the United States. The data were summarized by geographic region, metropolitan area size, hourly volume, time of day, and other variables. These data were obtained from three sources: (1) NCHRP, FHWA, and state research projects, (2) governmental agencies (federal, state, county, and city files), and (3) “In-house” databases assembled from transportation projects.

Recommended default values based on the data collected for this project are summarized in the following six subsections.

Heavy Vehicle Percentages for Uninterrupted Flow Facilities

1. Existing HCM Default Values
 - Freeways and multilane highways—10% (rural) 5% (urban)
 - Two-lane Highways—14% (rural) 2% (urban)
2. Variables Considered
 - Freeway, multilane, and rural two-lane facilities
 - Two population categories for two-lane and multilane highways: 5,000 to 50,000 and less than 5,000
 - Four population categories for freeways: less than 5,000; 5,000 to 50,000; 50,000 to 250,000; and greater than 250,000
3. Source of Data
 - Highway Performance Monitoring System from FHWA
4. Findings
 - Statistical differences were identified among states within each region. Thus, a wide variation of %HV by state is evident.
5. Recommended Default Value
 - Apply %HV that is specific to each state. See Chapter 3 of this Guidebook for those values.

PHFs for Uninterrupted Flow Facilities

1. Existing HCM Default Values
 - 0.88 (rural) and 0.92 (urban)
2. Variables Considered
 - Freeway, multilane, and rural two-lane facilities
 - Three time period categories (a.m., midday, and p.m.)
 - Four geographic regions
 - Four city-size categories
3. Sources of Data
 - California, Florida, Idaho, Ohio, Wisconsin
4. Findings
 - PHF did not vary by geographic region, time of day, or metro area size
5. Recommended Default Value
 - Although data were limited, the data generally support the continued use of the existing HCM Default Values. *Caution should be used in low volume situations where lower PHF values are likely to occur.*

Heavy Vehicle Percentages for Interrupted Flow Facilities

1. Existing HCM Default Values
2% (Signalized Intersections)
2. Variables Considered
Four city-size categories
Four geographic regions
Three time periods: (a.m., midday, and p.m.)
Six volume categories
3. Sources of Data
Arizona, Idaho, California, Florida, Maryland, Oregon, Utah, Washington, Wisconsin
4. Findings
No significant differences by region, city size, intersection type, or intersection control.
Variation occurs in %HV by total entering volume and peak period.
5. Recommended Default Value
Overall, it appears that a %HV Default Value of 3% is appropriate. As volume decreases, the %HV tends to increase. The %HV increases with decreasing city size.

PHFs for Interrupted Flow Facilities

1. Existing HCM Default Values
0.92 (Signalized Intersections)
2. Variables Considered
Signalized Intersections and Unsignalized Intersections (TWSC and AWSC)
Four city-size categories
Five geographic regions
Six volume categories
Three time period categories (a.m., midday, and p.m.)
3. Sources of Data
Arizona, Idaho, California, Florida, Maryland, Oregon, Utah, Washington, Delaware, Wisconsin
4. Findings
No significant differences by region, city size, intersection type, or intersection control.
Caution: PHF becomes lower than the HCM Default Value when total entering volume is less than 1,000 vehicles.
5. Recommended Default Value
The current default value of 0.92 should be used when the total entering volume is greater than 1,000 vehicles. Consider using a PHF of 0.90 or less when the total entering volume is less than 1,000 vehicles. The major street PHF can be used directly as an estimate of the intersection PHF, when the side street volumes are not readily available for planning applications.

Base Saturation Flow Rates for Signalized Intersections

1. Existing HCM Default Values
1,900 passenger cars per lane per hour (pcplph)
2. Variables Considered
Four city-size categories
Four geographic regions
3. Sources of Data
Arizona, Florida, Maryland, Indiana, Oregon, Texas, Nevada
4. Findings
When the observed base saturation flow rate is weighted by the number of headway observations that make up the mean at each site, the resulting mean is 1,894 pcplph (for larger cities).

5. Recommended Default Values

The HCM default value of 1,900 is reasonable for metropolitan areas of greater than 250,000. A default value of 1,750 should be used for metropolitan areas of less than 250,000.

Lane Utilization for Through Lanes at Signalized Intersections

1. Existing HCM Default Values

0.952 (2 through lanes)

0.908 (3 through lanes)

2. Variables Considered

Number of lanes in lane group

3. Sources of Data

Arizona, District of Columbia, Indiana, Oregon, Florida, Washington

4. Findings

For through lane groups with 2 and 3 lanes in the group, the measured lane utilization adjustment factors were very similar to the HCM Default Values. *Caution: Lane utilization values can be significantly influenced by the presence of freeway ramps located downstream of the intersection.*

5. Recommended Default Value

Although data were limited, the data generally support the continued use of the existing HCM Default Values.

Guidance on Default Values Based on Research Studies

This chapter provides information for input parameters where field data were not available. Default value guidance was developed based on a review of relevant research literature for six input parameters.

Pedestrian Walking Speeds and Start-up Times at Signalized Intersections

1. Existing HCM Default Values

4 ft/s (walking speed) at a signalized crosswalk for 15 percentile population

(HCM assumes 4 ft/s for 0–20% elderly pedestrians and 3.3 ft/s with greater than 20% elderly pedestrians)

3.2 s (start-up time) at a signalized crosswalk for 15 percentile population

2. Sources of Data

a. Fitzpatrick/Brewer/Turner Research—3.77 and 3.03 ft/s walking speeds (younger and older than 60 years, respectively). Recommends 3.5 ft/s for general population and 3.0 ft/s for older population.

b. Gates/Noyce/Bill/Van Ee Research—range of 3.8 to 3.3 ft/s walking speeds depending on age distribution

c. Knoblauch/Pietruchka/Nitzburg Research—3.97 and 3.08 ft/s walking speeds (younger and older than 65 years, respectively); 3.06 and 3.75 s start-up times

d. Public Right-of-Way Access Advisory Committee (2002 Guidelines)—3.0 ft/s for all ages

3. Findings

In the next edition of the MUTCD, a walking speed of 3.5 ft/s will be assumed for a signalized crosswalk when calculating the Flashing Don't Walk (FDW) from the near side curb or shoulder to the far side of the traveled way or median of sufficient width for pedestrians to wait. The guidance will also include a separate calculation for the total pedestrian time (Walk plus Flashing Don't Walk) using a default walking speed of 3.0 ft/s from 6 ft behind the curb to the far side of the traveled way.

4. Recommended Default Value

At a signal, the total pedestrian crossing time and associated components should be defined as follows:

- Total Pedestrian Time (Walk + Flashing Don't Walk) = 3.0 ft/s walking speed from 6 ft behind the curb to the far side of the traveled way or median of sufficient width for pedestrians to wait
- Pedestrian Clearance Time (Flashing Don't Walk) = 3.5 ft/s from curb to curb
- Walk interval = Total Pedestrian Time minus Pedestrian Clearance Time

Caution: Consider local traffic signal timing practices when determining pedestrian crossing times.

Interchange Ramp Terminals

1. Existing HCM Default Values

None

2. Default Values to Be Considered

- a. Lane utilization (external approaches only)
- b. Traffic pressure (a quantitative measure)
- c. Distance between intersections within an interchange

3. Sources of Data

New HCM Chapter 26. Chapter 26 covers diamond, partial cloverleaf (PARCLO), and single-point urban interchanges

4. Recommendations

- The lane utilization adjustment factor (f_{LU}) is an adjustment for base saturation flow rate. f_{LU} tables are provided in this Guidebook for seven interchange types.
- Traffic pressure adjustment factor reflects aggressive driving behavior when shorter headways are accepted during queue discharge. Adjustment factors are provided in this Guidebook for various cycle lengths and flow rates.
- Typical ranges of intersection separation distances (by interchange type) are provided in this Guidebook. Distances should be measured or taken from scaled drawings.

Driver Population Factors on Freeways

1. Existing HCM Default Value

1.00

2. Sources of Data

University of South Florida research report—Paper by Lu, Mierzejewski, Huang, and Cleland (1997); Literature summary by and data from Al-Kaisy and Hall (2001)

3. Findings

Driver population factors were developed in this prior research on the basis of speed-flow data.

4. Recommendations

- a. A procedure is recommended in this Guidebook for estimating a driver population factor based on a comparison of (1) observed capacity when regular commuters are using the freeway and (2) observed capacity when a different driver population is using the freeway. *Caution: Local knowledge of the freeway system is required to determine when different driver populations are likely to use the freeway system.*
- b. An example that illustrates the recommended methodology is provided.
- c. In general, HCM analyses should assume a driver population factor of 1.00. A lower value should be used only when there are special circumstances, such as sporting events or tourist routes, and when it is possible to estimate the driver population factor using this methodology.

Signal Density on Urban Streets

1. Existing HCM Default Values
Signal Density (sig/mi)—0.8, 3, 6, 10 (Urban Street Classes I–IV)
2. Recommendation
For signal density, it is recommended that no default value be provided in the HCM. If the number of signals per mile is not known, the analyst should conduct an assessment to determine which intersections are likely to warrant signals.

Free-Flow Speed on Urban Streets

1. Existing HCM Default Values
Free-flow speed (mph)—50, 40, 35, 30 (Urban Street Classes I–IV)
2. Existing HCM Procedures
Free-flow speed is defined as the speed that a through vehicle travels under low-volume conditions (200 veh/hr/ln or less) when all signals are green for the entire trip. The current HCM procedure adjusts free-flow speed based on lane width, lateral clearance, median treatment, and access points.
3. Summary of Relevant Research
The relationship between free-flow speed and speed limit and the relationship between free-flow speed and segment length are described in Chapter 4 of this report.
4. Findings
A procedure for estimating the base free-flow speed for an urban street is presented in Chapter 4. The base free-flow speed is defined to be the free-flow speed on long street segments such that the potential need to stop at the next signal does not have to be factored into the drivers' speed choice.
5. Recommendation
Apply the equation provided in Chapter 4 of this Guidebook to determine the base free flow speed. This procedure considers the posted speed limit, median type, and the presence of curb and gutter.

Saturation Flow Rates and Lane Utilization Factors for Dual and Triple Left Turn Lanes

1. Existing HCM Default Values
Dual left turn lane utilization—0.971
Triple left turn lane utilization—none provided
Dual and triple left turn saturation flow rate—none provided
2. Sources of Data
 - a. Spring, G. S., and Thomas, A. Double Left-Turn Lanes in Medium-Size Cities. *Journal of Transportation Engineering*, Vol. 125, March/April 1999: 138–143.
 - b. Zegeer, J. D. Field Validation of Intersection Capacity Factors. *Transportation Research Record No. 1091* (1986): 67–77.
 - c. Kagolanu, K., and Szplett, D. Saturation Flow Rates of Dual Left-Turn Lanes. *Proceedings of the Second International Symposium on Highway Capacity*, 1994, Akcelik, R. (ed.), Volume 1, pp. 325–344.
 - d. Stokes, R. W., Messer, C. J., and Stover, V. G. Saturation Flows of Exclusive Double Left-Turn Lanes. *Transportation Research Record No. 1091* (1986): 86–95.
 - e. Leonard II, J. D. Operational Characteristics of Triple Left Turns. *Transportation Research Record No. 1457* (1994): 104–110.
 - f. Sando, T., and Mussa, R. N. Site Characteristics Affecting Operation of Triple Left-Turn Lanes. *Transportation Research Record No. 1457* (1994): 104–110.
3. Recommendations
 - a. Left-Turn Lane Saturation Flow Adjustment Factor (Dual Left-Turn Lanes)—Set the Default Value to 0.97.

- b. Left-Turn Lane Utilization Factor (Dual Left-Turn Lanes)—Maintain the current Default Value of 0.971 as suggested by the HCM.
- c. Left-Turn Lane Saturation Flow Adjustment Factor (Triple Left-Turn Lanes)—Set the Default Value to 0.97 until research can be completed.
- d. Left-Turn Lane Utilization Factor (Triple Left-Turn Lanes)—Set the Default Value to 0.971 as suggested by the HCM until further research is available.

Caution: Lane utilization values can be significantly influenced by the presence of freeway ramps located downstream of the intersection.

Use of Service Volume Tables

A service volume table can provide an analyst with an estimate of the maximum number of vehicles a facility can carry at a given level of service (LOS). The use of a service volume table is most appropriate in certain planning applications where it is not feasible to evaluate every segment or node within a study area. Examples of this would be city, county, or statewide planning studies where the size of the study area makes it infeasible to conduct a capacity or level of service analysis for every roadway segment. For these types of planning applications, the focus of the effort is to simply highlight “potential” problem areas (for example locations where demand may exceed capacity or where a desired level of service threshold may be exceeded). For such applications, developing a service volume table can be a useful sketch planning tool, provided the analyst understands the limitations of this method.

For the purposes of this Guidebook, an example of how to construct a service volume table was prepared for a basic freeway segment and for an urban street facility. These two facility types were selected since they would likely be common applications of service volume tables within an urban area.

For the basic freeway segment example, the percent grade, PHF, and interchange density were varied over a range of values. The change in the maximum service volume at level of service “D” was evaluated. Varying the percent grade and PHF had a significant impact on the service volume thresholds. Varying the interchange density had a moderate impact on the service volume thresholds.

For the urban street facility example, the effective green ratio, signal density, and PHF were varied over a range of values. The change in the maximum service volume at level of service “D” was evaluated. Varying each of these three input parameters had a significant impact on the service volume thresholds.

This chapter illustrated two points: (1) the importance of selecting appropriate default values when constructing service volume tables (or conducting any planning or operational analysis that relies upon default values) and (2) some facilities are much more sensitive to default values than others.

Introduction

For over fifty years, the Highway Capacity Manual (HCM) has been viewed as the authoritative reference document for use in conducting engineering analyses aimed at determining the operational adequacy of a transportation facility. The fourth edition of the Highway Capacity Manual (HCM 2000) contains state-of-the-art methodologies for evaluating highway, transit, bicycle, and pedestrian facilities at both the operational and planning levels. The methodologies used to solve these problems require input parameters that depend on, in many cases, detailed site-specific data. While site-specific data may be available for the short-term focus of operational analysis, such data are often not available at the planning level. (This occurs because many planning analyses are conducted for future conditions where the geometric and operational characteristics of the facility are not known.) In addition, field measurements are often not made when conducting operational analyses. For the purpose of determining and comparing intermediate to long-term system improvements with HCM methodologies, default values for these input parameters can be used.

A default value is defined as a representative value that may be appropriate for estimating an input parameter in the absence of local data. Generic default values may be used for specific facility analyses, but will produce less accurate results than locally developed default values. Where local sources are unavailable, the HCM default values provided in Part II (Chapters 7 through 14) are provided.

Many of the HCM default values are not always applicable to given local conditions. This is true because the default values are based on limited data collected over several years or they are not provided. Prior to this project effort, no nationwide research effort had been conducted to assemble field measurements to determine if the default values contained in the HCM represent typical conditions.

The purpose of this Guidebook is to assist users of the HCM in the selection of default values for various HCM applications. This Guidebook describes the use of the current default values contained in the HCM and their application in planning practices. The sensitivity of the various default values on the analysis results is described. Changes to existing default values are recommended based on the analysis of an extensive set of data that was collected throughout the United States. When default values are not available, guidance is provided to help the analyst estimate appropriate values.

Current Planning Practices

The purpose of this chapter is to describe the development of the current HCM default values and the HCM recommended application of them. This chapter is divided into the following five sections:

- History of HCM 2000
- HCM 2000 guidance on the use of default values
- HCM Definitions
- Inventory of default values
- User survey results

History of HCM 2000

The origins of the current procedures of HCM 2000 are based on a series of research efforts which began in the late 1970s. A primary objective of these research efforts was to develop capacity and level of service procedures which were based on empirical data representing current traffic volume, traffic signal, and roadway characteristics. A number of these research efforts (NCHRP Project 2-28 series) culminated in the development of new procedures which were published in the 1985 HCM. In the 1994 HCM update, the procedures contained in six of the twelve chapters were the direct result of the research which focused on collection of large quantities of field data. Despite this effort, there were many specific areas of the 1994 HCM update that were primarily based on theoretical models, sometimes “calibrated” with a small amount of data.

The 1997 HCM update revised the procedure for determining capacity and density of basic freeway segments, based on the findings of NCHRP Project 3-45. The signalized intersection chapter was updated based on findings from research on actuated traffic signals (NCHRP Project 3-48). The delay equation was modified to account for signal coordination, oversaturation, variable length analysis periods, and the presence of initial queues at the beginning of the analysis period. Probably the biggest change in the 1997 HCM update was that control delay replaced stopped delay as the service measure. The chapter on unsignalized intersections was completely revised to incorporate the results of a nationwide research project that examined traffic operations at two-way and four-way stop-controlled intersections (NCHRP Project 3-46). The arterial streets chapter in the 1997 HCM incorporated the relevant changes from the signalized intersection chapter as well. It also established a new arterial classification for high-speed facilities. In addition, the delay equation was modified to account for the effect of platoons from upstream signalized intersections.

HCM 2000 was published in two versions: metric units and U.S. customary units. An accompanying multimedia CD-ROM included interactive tutorials, example problems, and hypertext. The number of chapters increased from 14 in the 1997 HCM to 31 in HCM 2000. HCM

Table 1. List of research efforts with significant contribution to HCM 2000.

Research Project	Research Title	Research Objective
NCHRP 3-55	Highway Capacity Manual for the Year 2000	Recommend user-preferred format and delivery system for HCM 2000
NCHRP 3-55(2)	Techniques to Estimate Speeds and Service Volumes for Planning Applications	Develop extended planning techniques for estimating measures of effectiveness (MOEs)
NCHRP 3-55(2)A	Planning Applications for the Year 2000 Highway Capacity Manual	Develop draft chapters related to planning for HCM 2000
NCHRP 3-55(3)	Capacity and Quality of Service for Two-Lane Highways	Improve methods to determine capacity and quality of service of two-lane highways
NCHRP 3-55(4)	Performance Measures and Levels of Service in the Year 2000 Highway Capacity Manual	Recommend MOEs and additional performance measures
NCHRP 3-55(5)	Capacity and Quality of Service of Weaving Areas	Improve methods for capacity and quality of service analyses of weaving areas
NCHRP 3-55(6)	Production of the Year 2000 Highway Capacity Manual	Complete HCM 2000 document
TCRP A-07	Operational Analysis of Bus Lanes on Arterials	Develop procedures to determine capacity and level of service of bus flow on arterials
TCRP A-07A	Operational Analysis of Bus Lanes on Arterials: Extended Field Investigations	Expand field testing and validation of procedures developed in TCRP Project A-07
TCRP A-15	Development of Transit Capacity and Quality of Service Principles, Practices, and Procedures	Provide transit input to HCM 2000
FHWA	Capacity Analysis of Pedestrian and Bicycle Facilities Project (DTFH61-92-R-00138)	Update method for analyzing effects of pedestrians and bicycles at signalized intersections; recommend improvements
FHWA	Capacity and Level of Service Analysis for Freeway Systems Project (DTFH61-95-Y-00086)	Develop procedure to determine capacity and level of service of a freeway facility

Source: HCM 2000, Exhibit 1-3.

NCHRP: National Cooperative Highway Research Program

TCRP: Transit Cooperative Research Program

FHWA: Federal Highway Administration

2000 was produced mainly from the NCHRP Project 3-55 series of research efforts that began in 1995. Table 1 summarizes research efforts that have significantly contributed to the contents of HCM 2000.

HCM 2000 Guidance on the Use of Default Values

HCM 2000 defines a default value as a representative value that may be appropriate for estimating an input parameter in the absence of local data. It further says that default values are to be used for planning applications to estimate the level of service, the volume that can be accommodated, or the number of lanes required. Chapter 9, Analytical Procedures Overview, describes guidance on the use of default values. This guideline states that

“Planning applications of the computation methods are described in Part III. Guidance for estimating input values and selecting default values for planning applications is given in Part II (Chapters 10 through 14). The analyst should observe the following suggestions when generating inputs to the analytical procedures.

- If the input variable can be observed in the field, measure it in the field.
- In performing a planning application for a facility not yet built, measure a similar facility in the area that has conditions similar to those of the proposed facility.
- If neither of the first two sources is available, rely on local policy or typical local/state values.
- If none of the above sources is available, default values provided in Part II (Chapters 10 through 14) of this manual may be used.”

This guidance was formulated by the NCHRP Project 3-55(6) panel to suggest a clear direction on the use of HCM default values. The NCHRP Project 3-55(6) panel also believed that it was important to add the following disclaimer when presenting example service volume tables in the HCM 2000.

“This table contains approximate values and is for illustrative purposes only. The values are highly dependent on the assumptions used. It should not be used for operational analyses or final design. This table was derived using the assumed values listed in the footnotes.”

The above disclaimer is intended to alert the user that the example service volume thresholds could vary substantially based on selected default values and assumptions. The analyst should not use service volume tables blindly as a decision making tool. It further states that default values used to generate example service volume tables should not be used as input variables for planning applications.

To assist the user in obtaining input parameters from similar facilities, Chapter 8, Traffic Characteristics, presents several observed input and output parameters—primarily documented in the early 1990s prior to the release of the 1994 HCM update. Most of the data were obtained from the Florida Department of Transportation (FDOT) and the Minnesota Department of Transportation. Even though this information is outdated, it can provide HCM users with typical ranges of input parameters for planning applications.

Appendix A of Chapter 9 in HCM 2000 contains guidelines on how to develop local default values. These guidelines were developed as part of the NCHRP Project 3-55(2)A research effort. Some of the suggestions include

- The best method for determining local default values for traffic parameters is to measure a sample of facilities in the field. If measuring local data is not feasible, an informal survey of local highway operating agencies can be conducted to determine standard design practices for new facilities and the condition of the facilities currently in place.
- Facilities can be stratified by area type and facility type to ensure reliable default values. The choice of categories is a local decision. Example sample stratification schemes may include central business district (CBD), suburban, and rural.
- It is suggested that the default value for each category be the arithmetic mean of the observations. In addition, the variation in the observed value for each category should be compared with the difference in the means for each category. Analysis of variance techniques may be used to determine whether categories should be consolidated.
- The sample size required for each category can be determined by the desired accuracy in the resulting input estimate and the variation in the observed values. The following equations are provided to determine the minimum sample size that will allow the analyst to compute the mean and estimate the margin of error in the estimated mean with 90% or better confidence.

$$n \geq \frac{4s^2}{(\xi)^2}$$

Where

- n = minimum number of observations to meet accuracy goal for mean;
- ξ = maximum desirable error in the estimate of the mean (at the desired confidence level);
- and
- s = estimated standard deviation for the sample, computed using the following equation.

$$s^2 = \frac{\sum (x_i - \bar{x})^2}{n-1}$$

Where

x_i = i th observation of the value,
 \bar{x} = mean value of the observations, and
 n = number of observations.

The standard deviation is the most common measure of statistical dispersion, measuring how widely spread the values in a data set are. If the data points are close to the mean, then the standard deviation is small. If many data points are far from the mean, then the standard deviation is large.

Two observations can be made with regard to default values. One observation is that default values are typically defined by transportation agencies responsible for the planning (or preliminary engineering) of streets or highways. These default values are tailored to be representative of conditions in the agency's jurisdiction. To ensure the accuracy and consistency of any evaluation, engineers within the agency draw on their familiarity with their transportation system to identify appropriate default values. In some instances, several default values are identified for a given variable or factor, with the appropriate value being dependent on area type (i.e., urban, rural), area population, or facility functional class.

A second observation is that default values for input variables are rarely a product of research. Research is typically used to develop new models or evaluate existing models. The data collected for these purposes tend to support a new model's framework or provide insight into existing model accuracy. However, a database assembled for this type of research does not often have the depth and breadth (from the standpoint of geography, area type, population and functional class) to yield default values that are representative of every situation in which the model may be used.

In recognition of the aforementioned observations, researchers developing new models often include input variables and calibration factors in their models for which practitioners are expected to provide the appropriate values. These values ensure the desired accuracy of the evaluation by adapting the equation to the unique features of the facility and the behavior of drivers in their jurisdiction. Through experience, the practitioner determines which variables and factors require measurement prior to each analysis and which can be defaulted.

Research publications rarely contain recommendations for default values for input variables or calibration factors that have a significant influence on model accuracy. However, researchers do sometimes recommend default values for calibration factors that have a medium-to-small level of influence, and that are believed to be relatively stable (or invariant) among geographic regions, area types, population sizes, and functional classifications. Also, researchers explore correlations between various input variables and calibration factors for the purpose of developing predictive equations. Such equations are used to estimate a factor as a function of one or more other, more readily available variables or factors. In this manner, the need to measure a specific factor for an evaluation is eliminated. As an example, research has shown start-up lost time is a function of saturation flow rate. This relationship can be used by practitioners to estimate start-up lost time without having to measure it in the field or estimate it using a global constant. Similar relationships have been developed for estimating phase end lost time (as a function of approach speed) and free-flow speed (as a function of speed limit).

HCM Definitions

This section defines several terms related to default values used in the analysis of interrupted and uninterrupted flow facilities and points.

Input Parameter is a variable that is included in an equation because it has an influence on the dependent variable and its value is likely to vary significantly over the range of possible equation applications. Hence, a value should be provided for each input parameter by analysts each time they use the equation to ensure an accurate estimate of the dependent variable. Input parameters can be measured in the field or estimated using approximation techniques. Default values are sometimes used for input parameters that tend to be difficult to measure (or estimate) or those variables that have minimal impact on equation accuracy. Example input parameters include turn movement volume, number of lanes, signal phase sequence, and signal phase duration.

Calibration Factor is a variable that is included in an equation because it has an influence on the dependent variable. It is assigned a constant value for most applications. It is used to adjust the equation's predicted value such that this value reflects local conditions without bias. If the factor has a theoretic basis or is recognized as a universal constant, then the factor is often referred to as an input parameter. Calibration factors can be measured using field data or estimated using regression analysis. Default values are sometimes used for those calibration factors that tend to be difficult to measure (or estimate) or those factors that have minimal impact on equation accuracy. Example calibration factors include base saturation flow rate, left-turn sneakers per cycle, start-up lost time, and passenger-car equivalent (PCE) for heavy vehicles.

Default Value is a constant to be used in an equation as a substitute for a field measured (or estimated) value. Default values can be used for input variables or calibration factors. The value selected should represent a typical value for the conditions being analyzed. Default values are generally used for planning, preliminary engineering, or other applications of the HCM that do not require the accuracy provided by a detailed operational evaluation.

Area Type is a characterization of the population in the vicinity of the subject facility. Four area types are typically used by planning agencies: urbanized, transitioning, urban, and rural. An urbanized area is defined as an area having a population of 50,000 or more within a contiguous area. A transitioning area is an area adjacent to an urbanized area and expected to become part of that area in the next 20 years. An urban area is an area with a population over 5,000 that is not considered to be urbanized or transitioning. A rural area is any area that is not urbanized, transitioning, or urban.

Design Category is a characterization of the geometric features of a street and its roadside environment. Four design categories are defined for urban streets in Chapter 10 of the HCM. They are listed in Table 2. The High Speed category describes streets with long distances between signals, no adjacent parking, few driveways, and little roadside development. At the other end of the spectrum is the Urban category that describes streets with a short length, adjacent parking, many driveways, and considerable roadside development. Streets that fit the Urban category are often found in downtown areas and CBDs.

Through Lanes are the total number of lanes in the roadway cross-section that extend for the full length of the street segment (as measured between signalized intersections). A lane added and dropped at a signalized intersection may be included in the count of through lanes if the combined length of the add/drop lane allows the lane to operate at the intersection with an efficiency that is near to (or exceeds) that of a through lane.

Table 2. Urban street design categories.

Characteristic	Design Category			
	High Speed	Suburban	Intermediate	Urban
Driveway density	Very low	Low	Moderate	High
Arterial type	Multilane divided; undivided or two lane with shoulders	Multilane divided; undivided or two lane with shoulders	Multilane divided or undivided; one way, two lane	Undivided one way, two way, two or more lanes
Parking	No	No	Some	Significant
Separate left-turn lanes	Yes	Yes	Usually	Some
Signals per mile	0.5-2	1-5	4-10	6-12
Speed limit	45-55 mph	40-45 mph	30-40 mph	25-35 mph
Pedestrian activity	Very little	Little	Some	Usually
Roadside development	Low density	Low to medium density	Medium to moderate density	High density

Inventory of Default Values

Part II (Chapters 7 through 14) of HCM 2000 presents the traffic flow concepts associated with each of the uninterrupted and interrupted facility types included in the manual. Part II chapters also include discussions of typical capacity parameters. In the past versions of the HCM, these concepts were presented together with the methodology for each facility. Default values are also offered in Part II chapters to assist the analyst in obtaining input values for planning applications using the methodologies that are presented in Part III. Table 3 summarizes the suggested default values by point and facility as well as the original research and data sources, and the categorization scheme of each input parameter or adjustment factor. The remainder of this chapter provides detailed explanations of the input parameters listed in Table 3. Explanation topics include summary of original research, data source, and potential categorizations.

General Traffic Characteristics

The K, D, and PHF default values were obtained from the research effort completed under NCHRP Project 3-55(2)A. The current classification of urban and rural default values was derived from Florida's Level of Service Standards and Guidelines Manual for Planning, Exhibit 8-9 of the HCM 2000 shown herein as Table 4 illustrates FDOT facility classifications and associated descriptions of facility classifications.

There are two levels of analysis included in the Florida Level of Service Manual. They are "generalized" planning and "conceptual" planning. Generalized planning makes extensive use of statewide default values and is intended for broad applications such as statewide analyses, initial problem identification, and future year analyses. The K100 default values shown in Table 4 are used for the Generalized Tables which were extensively researched and represent the most appropriate statewide default values. Even though not explicitly noted in Exhibit 8-9 of HCM 2000, the K100 factors reflect the 100th highest hour. (Note that there is an updated version of the Florida Level of Service Manual with a new title: 2002 Quality/Level of Service Handbook.) In other states

Table 3. Inventory of HCM 2000 default values.

Input Parameter/ Adjustment Factor	Default Value	Varies by	HCM 2000 Source Exhibit	Original Source ^a
General Traffic Characteristics				
PHF	0.92/0.88	Urban/Rural	9-2	Ref. 1
K	0.09/0.10	Urban/Rural	9-2	Ref. 1
D	0.60	-----	9-2	Ref. 1
Urban Streets				
Free-flow speed (mph)	50/40/35/30	Urban Street Class	10-5	Ref. 2
Signal density (signals/mi)	0.8/3/6/10	Urban Street Class	10-6	Ref. 2
Signalized Intersections				
Exclusive turn lane required	100 veh/hr – 300 veh/hr	Single vs. double exclusive turn lane	10-13	Ref. 3
PHF	0.92	-----	10-12	Ref. 1, 4, and 5
Length of analysis period (hr)	0.25	-----	10-12	Ref. 6
Cycle Length (s)	70/100	CBD/other	10-16	Ref. 5
Lost time (s/cycle)	16/12/8	No. of phases and protected/permited	10-17	Ref. 5
Arrival Type (AT)	3,4	Uncoordinated/coordinated	10-12	Ref. 5, 6, and 22
Unit extension time (s)	3.0	-----	10-12	Ref. 5
Actuated control adjustment factor (k)	0.40	-----	10-12	Ref. 5
Upstream filtering adjustment factor (l)	1.00	Assuming isolated intersection	10-12	Ref. 5
Adjusted sat flow (veh/hr/ln)	1700/1800	CBD/other	10-19	Ref. 5
Base sat flow (pc/hr/ln)	1900	-----	10-12	Ref. 5 and 6
Lane widths (ft)	12	-----	10-12	Ref. 7
Heavy vehicles	2%	-----	10-12	Ref. 5
Grades	0%	-----	10-12	Ref. 4
Parking maneuvers	16/8/32	Street type/No. of spaces/Time Limit/Turnover rate	10-20	Ref. 5
Local bus frequency (buses stopping/hr)	12/2	CBD/other	10-21	Ref. 5
Pedestrians (peds/hr)	400/50	CBD/other	10-22	Ref. 5
Lane utilization (f_{LU})	1.000/0.952/0.908/0.971/0.885	Movement/No. of lanes in Lane Group	10-23	Ref. 6
Average queue spacing (ft)	25			Ref. 4
Pedestrians				
Effective sidewalk width (ft)	5.0/7.0	Buffer zone/No buffer zone	11-13	Ref. 7
Street corner radius (ft)	45.0/25.0	Trucks & buses/No trucks and buses	11-14	Ref. 4
Pedestrian walking speed (ft/s)	4.0	-----	11-12	Ref. 8
Pedestrian start-up time (s)	3.0	-----	11-12	Ref. 9
Number of pedestrians in a platoon (ped)	Equation	Vehicular flow rate/single pedestrian critical gap	11-12	Ref. 10
Bicycles				
Bicycle path width (ft)	8.0	-----	11-19	Ref. 11
PHF	0.80	-----	11-19	Ref. 12 and 13
Bicycle speed (mph)	15.0	-----	11-19	Ref. 14

(continued on next page)

Table 3. (Continued).

Input Parameter/ Adjustment Factor	Default Value	Varies by	HCM 2000 Source Exhibit	Original Source ^a
Multilane Highways				
Lane width (ft)	12.0	-----	12-3	Ref. 7
Lateral clearance (ft)	6.0	-----	12-3	Ref. 7
Access point density (points/mi)	8/16/25	Rural/Low-density/High- density	12-4	Ref. 15
Specific grade or general terrain	Level	-----	12-3	Ref. 7
Base free-flow speed (mph)	60	-----	12-3	Ref. 15
Length of analysis period (min)	15	-----	12-3	Ref. 15
PHF	0.88/0.92	Rural/Urban	12-3	Ref. 1, 4, and 5
Heavy vehicles (%)	10%/5%	Rural/Urban	12-3	Ref. 5
Driver population factor	1.00	-----	12-3	Ref. 15 and 16
Two-Lane Highways				
Lane width (ft)	12.0	-----	12-9	Ref. 7
Shoulder width (ft)	6.0	-----	12-9	Ref. 7
Access point density (points/mi)	8/16/25	Rural/Low-density/High- density	12-4	Ref. 15
Specific grade or general terrain	Level	-----	12-9	Ref. 7
Percent no-passing	20%/50%/80%	Level/rolling/mountainous	12-11	Ref. 17
Length of passing lanes (mi)	0.5/0.75/1.0/2.0	Directional flow (100/200/400/>700/pc/hr)	12-12	Ref. 18
Length of analysis period (min)	15	-----	12-9	Ref. 19
PHF	0.88/0.92	Rural/Urban	12-9	Ref. 1, 4, and 5
Directional split	60/40 or 80/20	Rural & Urban or Recreational	12-13	Ref. 19
Heavy vehicle percentages (trucks/buses)	14%/2%	Rural/Urban	12-14	Ref. 19
Heavy vehicle percentages (RVs)	4%/0%	Rural/Urban	12-14	Ref. 19
Basic Freeway Segments				
Lane width (ft)	12.0	-----	13-5	Ref. 7
Lateral clearance (ft)	10.0	-----	13-5	Ref. 7
Specific grade or general terrain	Level	-----	13-5	Ref. 7 and 15
Base free-flow speed (mph)	75/70	Rural/Urban	13-5	Ref. 20
Length of analysis period (min)	15	-----	13-5	Ref. 20
PHF	0.88/0.92	Rural/Urban	13-5	Ref. 1, 4, and 5
%HV	10%/5%	Rural/Urban	13-5	Ref. 5
Driver population factor	1.00	-----	13-5	Ref. 20 and 16
Ramps and Ramp Junctions				
Acceleration lane length (ft)	590	-----	13-17	Ref. 7
Deceleration lane length (ft)	140	-----	13-17	Ref. 7
Ramp free-flow speed (mph)	35	-----	13-17	Ref. 21

Table 3. (Continued).

Input Parameter/ Adjustment Factor	Default Value	Varies by	HCM 2000 Source Exhibit	Original Source ^a
PHF	0.88/0.92	Rural/Urban	13-17	Ref. 1, 4, and 5
%HV	10%/5%	Rural/Urban	13-17	Ref. 5
Driver population factor	1.00	-----	13-17	Ref. 21 and 16

a. Original source references are listed below.

1. Florida's Level of Service Standards and Guidelines Manual for Planning. Systems Planning Office, Florida Department of Transportation, Tallahassee, 1995.
2. New Highway Capacity Manual. NCHRP Project 3-28B, Polytechnic University, Brooklyn, N.Y., 1985.
3. Harwood, D. W., M. T. Pietrucha, M. D. Wooldridge, R. E. Brydia, and K. Fitzpatrick. *NCHRP Report 375: Median Intersection Design*. TRB, National Research Council, Washington, D.C., 1995.
4. Production of the Highway Capacity Manual 2000. NCHRP Project 3-55(6), Tucson, Arizona, 2000.
5. Planning Applications for the Year 2000 Highway Capacity Manual. NCHRP Project 3-55(2)A, Dowling Associates, Inc., Oakland, California, 1997.
6. Urban Signalized Intersection Capacity. NCHRP Project 3-28(2), Tucson, Arizona, 1982.
7. American Association of State Highway and Transportation Officials, A Policy on Geometric Design of Highways and Streets. Washington, D.C., 1994.
8. Manual on Uniform Traffic Control Devices. Federal Highway Administration, Washington, D.C., 1988.
9. Knoblauch, R. L., M. T. Pietrucha, and M. Nitzburg. Field Studies of Pedestrian Walking Speed and Start-Up Time. In *Transportation Research Record 1538*, TRB, National Research Council, Washington, D.C., 1996, pp. 27–38.
10. Gerlough, D., and M. Huber. *Special Report 165: Traffic Flow Theory: A Monograph*. TRB, National Research Council, Washington, D.C., 1975.
11. American Association of State Highway and Transportation Officials. Guide for the Development of Bicycle Facilities. Washington, D.C., 1991.
12. Hunter, W. W., and H. F. Huang. User Counts on Bicycle Lanes and Multi-Use Trails in the United States. In *Transportation Research Record 1502*, TRB, National Research Council, Washington D.C., 1995, pp. 45–57.
13. Niemeier, D. Longitudinal Analysis of Bicycle Count Variability: Results and Modeling Implications. *Journal of Transportation Engineering*, Vol. 122, No. 3, May/June 1996, pp. 200–206.
14. Safety and Locational Criteria for Bicycle Facilities, User Manual Volume II: Design and Safety Criteria. Report FHWA-RD-75-114. FHWA, U.S. Department of Transportation, 1976.
15. Reilly, W., D. Harwood, J. Schoen, and M. Holling. Capacity and LOS Procedures for Rural and Urban Multilane Highways. NCHRP Project 3-33 Final Report, JHK & Associates, Tucson, Arizona, May 1990.
16. Lu, J.J., W. Huang, E. Mierzejewski. Driver Population Factors in Freeway Capacity. Center for Urban Transportation Research, University of South Florida, Tampa, Florida, May 1997.
17. Zegeer, J., "Survey of Highway Operating Agencies," Kittelson & Associates, Inc., Fort Lauderdale, Florida, 1998.
18. Harwood, D. W., and A. D. St. John. Operational Effectiveness of Passing Lanes on Two-Lane Highways. Report No. FHWA/RD-86/196, FHWA, U.S. Department of Transportation, Washington, D.C., 1986.
19. Harwood, D. W., A. D. May, I. B. Anderson, L. Leiman, and A. R. Archilla. Capacity and Quality of Service of Two-Lane Highways. Final Report, NCHRP Project 3-55(3), Midwest Research Institute, 1999.
20. Schoen, J., A. May, W. Reilly, and T. Urbanik. Speed-Flow Relationships for Basic Freeway Sections. Final Report, NCHRP Project 3-45. JHK & Associates, Tucson, Arizona, May 1995.
21. Roess, R., and J. Ulerio. Capacity of Ramp-Freeway Junctions. Final Report, NCHRP Project 3-37. Polytechnic University, Brooklyn, N.Y., Nov. 1993.
22. Fambro, D.B., E.C.P. Chang, C.J. Messer. Effects of Quality of Traffic Signal Progression on Delay. NCHRP Project 3-28(C), Texas Transportation Institute, College Station, Texas, August 1989.

Table 4. Typical K factors (HCM 2000, Exhibit 8-9 [modified]).

Area Type	K100-Factor
Urbanized	0.091
Urban	0.093
Transitioning/Urban	0.093
Rural Developed	0.095
Rural Undeveloped	0.100

NOTES: Urbanized—Areas designated as urban by the U.S Bureau of the Census.

Urban—Areas with a population >5,000 not already included in an urbanized area.

Transitioning/Urban—Areas outside of an urbanized area or a rural area with a population <5,000 expected to be included in an urbanized area within 20 years.

Rural—Areas not included in urbanized, urban, or transitioning/urban.

where K30 factors are used, the resulting adjustment to a peak hour volume for analysis purposes will be higher.

Exhibit 9-2 of HCM 2000 presents generalized default values of K, D, and PHF categorized for urban and rural area types. These default values are applicable to all the methodologies in the HCM 2000. Conceptual planning makes use of default values and input parameters that are relevant to the local conditions. Conceptual planning is intended for more near-term corridor analyses.

Urban Streets

The original methodology for urban streets was developed as part of NCHRP Project 3-28B prior to the publication of the 1985 HCM. As in the case of several other chapters, the procedure for the analysis of arterials has been updated several times since 1985. Some of the updates include findings of two research efforts: Project NCHRP 3-48, which studied traffic actuated control and an FHWA-sponsored project, which studied arterial traffic operations. In addition to expanding and validating the delay model as was done for the signalized intersection model, the effect of progression and upstream signal operation on delay was addressed in the FHWA project. In both research projects, theoretical models were validated using limited field data as well as simulation data generated by NETSIM (NETwork SIMulation). Note that there is an on-going research project, Project NCHRP 3-79, “Measuring and Predicting the Performance of Automobile Traffic on Urban Streets.” The intent of this research is to completely replace the current HCM 2000 methodology.

Urban streets are classified into two major categories, Principal Arterial and Minor Arterial. These classifications come from the 2004 AASHTO Policy on Geometric Design of Highways and Streets on travel volume, mileage, and the character of service the arterial is intended to provide. The HCM 2000 also classifies urban streets in four design categories (I, II, III, and IV), which are somewhat different than AASHTO’s classifications. The design categories depend on driveway/access density, arterial type, parking, left-turn bays, signals per mile, posted speed limit, pedestrian activity, and roadside development. Users familiar with the 1994 HCM should note that the former design categories I, II, and III are now categories II, III, and IV, respectively. Since then, a new design category I and appropriate running time values have been added for high speed streets with free-flow speeds higher than 45 mph.

Free-flow speeds of urban streets are provided for the four design categories to allow the user to measure free-flow speed and, in so doing, determine a more accurate running time per mile from Exhibit 15-3. If field measured free-flow speed is not available, then 50, 40, 35, and 30 mph can be used for design categories I, II, III, and IV, respectively.

Signalized Intersections

The procedure for analysis of signalized intersection operation was initially developed as a result of a fairly extensive study of 35 intersections under Project NCHRP 3-28(2). The overall procedure which was developed as part of that study was validated using field data from eight intersections. The current control delay equations were primarily developed based on the Australian method, which has its roots in Webster's classic delay formulation, and in various theoretical approaches that bridge the gap between volume-to-capacity (v/c) ratios of 0.85 or less (where Webster's model is fairly accurate) and very high v/c ratios of 1.2 or more, where several theoretical overflow delay models are accurate. The validation results for the 1985 HCM procedure are summarized in Table 5.

The need for an exclusive left-turn lane is determined by the volume of left-turning traffic, opposing volumes, and safety considerations. Exclusive left-turn lanes are also warranted when an exclusive left-turn phase is warranted at a signalized intersection. Exclusive left-turn lane warrant threshold volumes, presented in Exhibit 10-13 of HCM 2000, were developed by a research effort that looked at 40 intersections across the country, including two-way stop-controlled, all-way stop-controlled, and signalized controlled intersections on multilane highways. The details of this research are documented in *NCHRP Report 375*.

NCHRP Project 3-55(2)A develops greater classifications of default values and ranges for cycle length than are presented in HCM 2000. NCHRP Project 3-55(2)A results are summarized in Table 6. (The use of the terms CBD, urban, suburban, and rural in Tables 6 through 9 are based on general assessments of the area and are not necessarily consistent with the Area Type definitions provided previously in this chapter.) These default values were recommended based on the practical experience of the research team and NCHRP Project 3-55(2) panel members.

The 1985 HCM recommended five arrival types and platoon ratios. The 1994 HCM contained a revised delay prediction model developed from the NCHRP Project 3-28(C) research effort. This model is essentially a theoretical construct, modified from the 1985 HCM, and calibrated to a field-data set. The revised model adds a sixth arrival type to describe progression quality, recalibrates the relationship between arrival type and "platoon ratio," and applies revised progression adjustment factors to only the uniform delay term in the predictive algorithm. HCM 2000 default values only distinguish between coordinated and uncoordinated signal systems.

HCM 2000 default values for adjusted saturation flow rate per lane are best estimates recommended by NCHRP Project 3-55(2)A with slight modification to reflect only two categories of

Table 5. Signalized intersection methodology validation (NCHRP Project 3-55).

Delay Estimates	15-Minute Samples	R ²
Through plus Right-Lane Group	113	0.52
Left-Turn Lane Group	70	0.26
Approach	104	0.53
Intersection	23	0.59

Note: R² squared is a descriptive measure of a model that varies between 0 and 1. The closer the R² value is to one, the better the model performs.

Table 6. Default cycle lengths (NCHRP Project 3-55[2]A).

Area Type	Default (s)	Range (s)
CBD	60	45-90
Urban	80	60-100
Suburban	100	80-120
Rural	N/A	N/A

Table 7. Adjusted saturation flow rate by area type (NCHRP Project 3-55[A]).

Area Type	Default (veh/hr/ln)	Range (veh/hr/ln)
CBD	1700	1600-1800
Urban	1750	1700-1900
Suburban	1800	1800-1900
Rural	1700	1600-1900

area type. The NCHRP Project 3-55(2)A report recommended four area type categories as shown in Table 7. The research also suggested that a 20% increase may be applied if there is a median present and/or exclusive left-turn lanes are provided at the signalized intersection lane group. These recommendations are all based on best judgments of the research team and NCHRP Project 3-55(2) panel members. Interestingly, the 1985 HCM recommended an adjusted saturation flow rate of 1600 veh/hr/ln with an accompanying warning that the use of this default value will make the analysis highly approximate.

In the 1985 HCM, the base saturation flow rate was 1,800 pc/hr/ln. Since then, many surveys were conducted that suggested that the base saturation flow rate for a signalized intersection is indeed higher than 1,800 pc/hr/ln. Although base saturation flow rate has been a variable which can be changed by the analyst based on local conditions, the default value in the 1994 HCM was changed to 1,900 pc/hr/ln. According to the NCHRP Project 3-55(2)A recommendation as presented in HCM 2000, approaches with an operating speed less than 30 mph have a lower base saturation flow rate (1800 pc/hr/ln) while approaches with an operating speed greater than 50 mph have a higher base saturation flow rate (1,900 pc/hr/ln).

NCHRP Project 3-55(2)A recommendations present additional categorical classification for default pedestrian flow rates than what is presented in the HCM 2000. Table 8 presents the NCHRP Project 3-55(2)A recommendations.

The lane utilization factors in Exhibit 10-23 of HCM 2000 were developed as part of NCHRP Project 3-28(2) and were based on average volume distributions observed at 15 sites. Since then, the Signalized Intersection Subcommittee of the Highway Capacity and Quality of Service Committee has made lane utilization to be a saturation flow rate adjustment factor, as opposed to a delay adjustment factor.

Pedestrians

The origin of the HCM 2000 pedestrian chapter is the 1985 HCM. The methodology adapted several basic pedestrian flow relationships originally observed and calibrated by the following two research efforts.

- Pushkarev, B., and J. Zupan, *Urban Space for Pedestrians*. MIT Press, Cambridge, MA, 1975.
- Fruin, J., *Pedestrian Planning and Design*. Metropolitan Association of Urban Designers and Environmental Planners, New York, N.Y., 1971.

Table 8. Pedestrian flow rate by area type (NCHRP Project 3-55[2]A).

Area Type	Pedestrians/hr
CBD	400
Urban	200
Suburban	50
Rural	0

Formulations for crosswalks and street corners were theoretical models based on time-space concepts developed by Fruin. While basic relationships were calibrated to field data (all collected in New York City), crosswalk and street corner methodologies still have not been extensively validated. All of the pedestrian speed-density, flow-density, and speed-flow relationships presented in Chapter 11 of the HCM 2000 come from the Pushkarev and Zupan's 1975 research effort. Table 13-1 of the 1985 HCM presents walkway width, observed pedestrian flow rates compiled by Roger Roess and Herb Levinson from sites in Boston, Chicago, Los Angeles, Des Moines and Ames, Iowa, New York City, Washington, D.C., Seattle, San Francisco, and Winnipeg.

The 1994 HCM recommends a pedestrian walking speed of 4.5 ft/s as the default value. Based on the findings of an FHWA research project, "Recommended Procedures for Chapter 13, 'Pedestrians' of The Highway Capacity Manual," the walking speed default value was reduced to 4.0 ft/s. Greater emphasis was placed by this research on the importance of determining the proportion of elderly pedestrians (65 years of age and older) in the walking population. Chapter 18 of HCM 2000 recommends that if 0 to 20% of pedestrians are elderly, then a walking speed of 4.0 ft/s is appropriate. If the elderly walking population exceeds 20%, then 3.3 ft/s is appropriate. In addition, an upgrade of 10% or greater reduces walking speed by 0.3 ft/s.

Field studies of pedestrians' walking speed and start-up time were performed relative to site and environmental factors, including street width, posted speed, curb height, grade, number of vehicle travel lanes, signal cycle length, pedestrian-signal type, street functional classification, crosswalk type, and channelization and were documented in *Transportation Research Record 1538: "Pedestrian and Bicycle Research."* Data were collected at sixteen crosswalks in four urban areas. The research recommended a default pedestrian walking speed of 4.0 ft/s and a pedestrian start-up time of 3.0 s, which are essentially the same as the HCM 2000 default values.

Bicycles

According to the AASHTO Policy on Geometric Design of Highways and Streets, on-street bicycle lane width should be a minimum of 5 ft. For short lengths of an off-street bicycle path or for connectors, a minimum acceptable width is 8 ft. A 10-ft wide off-street bicycle path is the standard. The HCM 2000 default value for off-street bicycle path width is 8 ft for a two-lane path and 10 ft for a three-lane path.

When using the HCM 2000 bicycle methodology, the analyst should keep in mind that bicycle flow peaking characteristics are very different from motor vehicles. Bicycle volumes peak more abruptly. Daily volumes, or even hourly volumes, may not appear to be very substantial until this peaking is considered. One study in Madison, Wisconsin, measured peak-hour volumes as 10 to 15% of total daily volume at various locations. Another study in the State of Washington (conducted primarily in the Seattle area) measured PHFs of between 0.52 and 0.82 at various locations. Using these findings as a basis, the FHWA research "Recommended Procedures for Chapter 14, Bicycles of The Highway Capacity Manual" recommended a PHF of 0.80 as a default value in absence of local data. This default was included in the HCM 2000.

A manual released by FHWA, "Safety and Locational Criteria for Bicycle Facilities, User Manual Volume II: Design and Safety Criteria," reported that the 85th percentile speed of bicycles is approximately 15 mph and that a design speed of 20 mph on level terrain would allow for nearly all bicyclists to travel at their desired speeds. Based on these findings, the FHWA research prior to the publication of HCM 2000—"Recommended Procedures for Chapter 14, Bicycles of The Highway Capacity Manual"—recommended 15 mph as a default bicycle travel speed.

Multilane Highways

The multilane highway procedure was developed prior to the publication of the 1985 HCM as part of NCHRP Project 3-33. The procedure was developed based on an extensive field study which covered some 47 sites across the United States. Over 530 15-minute samples were used to establish the speed-flow relationship and analysis procedure. The multilane highway analysis procedure consists of two components used to estimate average travel speed and density. These components are flow rate and free-flow speed. In general, variation of lane width, median type, and access points per mile were found to account for 48% percent ($R^2 = 48$) of observed variation in speed.

AASHTO design guidelines for multilane highways recommend a 12-ft lane width and 6-ft shoulder width. These values were included in the HCM 2000 as default values.

The access point density observed at the NCHRP Project 3-33 field sites was 11 access points/mi. However, access point density as high as 53 access points/mi was also found. Access points were not differentiated between driveways or side streets. Only access points on the right-hand side of the travel way were considered. The NCHRP Project 3-33 findings are recommended as default values in the HCM 2000 (Exhibit 12-4).

The general terrain type can be used instead of specific grades whenever there is no single grade on the highway segment that extends for more than 1 mi or the grade exceeds $\pm 3\%$ for more than 0.5 mi. Even though “level” general terrain is recommended as the default value in the HCM 2000, additional guidance is given in the HCM 2000. The directions described for selecting a default general terrain are

- If average extended terrain is less than 3%, then use “Level Terrain,”
- If average extended terrain is between 3 to 7%, then use “Rolling Terrain,” or
- If average extended terrain is greater than 7%, then use “Mountainous Terrain.”

The base free-flow speed for multilane highways was defined by NCHRP Project 3-33 as the operating speed under ideal roadway conditions, including 12-ft lane widths, a divided highway with median, greater than 6-ft lateral clearance in both the median and the right side of the highway, and no access points. The recommended base free-flow speed for ideal conditions is 60 mph.

NCHRP Project 3-55(2)A suggests that the Highway Performance Monitoring System (HPMS) from the FHWA can be used to obtain local information on the percent of heavy vehicles by facility and area type. If the breakdown between RVs, trucks, and buses is not known, then it is recommended that heavy vehicles be considered to be all trucks.

As part of NCHRP Project 3-33, driver population was surveyed informally during the field studies. No definitive result was obtained concerning the operational effects of a commuter versus recreational driver population. In all of the sites studied, commuter traffic (with in-state license plates) accounted for 90 to 95% of the total volume. The 1985 HCM, Chapter 3, Basic Freeway Sections methodology states that the driver population factor generally ranges from 0.75 to 1.0. This factor is primarily based on California Department of Transportation (Caltrans) studies performed in the early 1970s on California freeways. Unfortunately, these traffic studies performed by Caltrans were internal working memos and are not currently available for review. A 1997 FHWA research project, Driver Population Factors in Freeway Capacity, collected several data sets across the State of Florida and determined that the HCM driver population factors should be in the range 0.85 to 1.0. Based on the Florida study results, the HCM 2000 recommends that if a significant portion of the driver population consists of recreational drivers, a population factor of 0.85 should be used.

Two-Lane Highways

The original two-lane highway methodology was presented in the 1985 HCM. It was based on a complex set of algorithms developed using field data, data generated by a simulation model, and published results of foreign two-lane operations. The model was calibrated using limited field data. One aspect of the 1985 HCM procedure which was developed using field data was the passenger-car equivalencies for heavy vehicles on two-lane highways. Since then, NCHRP Project 3-55(3) collected traffic flow data at a total of 20 sites in four states and one Canadian province to improve the two-lane highway simulation TWOPAS, and develop a new procedure that is currently provided in Chapter 20 of the HCM 2000. The data collected at the 20 sites included traffic volumes, speed, platooning data on high-volume two-lane highways, comparison of speeds upstream and downstream of shoulder width transitions on two-lane highways, truck crawl speeds on steep upgrades, and traffic operations on steep downgrades.

AASHTO design guidelines for two-lane highways in the United States recommend a 12-ft lane width and 6-ft shoulder width for high speed facilities. The HCM 2000 adopted these standard widths as default values.

As part of NCHRP Project 3-55(2)A, Kittelson & Associates, Inc., surveyed 25 agencies across the United States to identify default values of various HCM input parameters. Responses were received from 13 of the 25 agencies surveyed. The survey addressed various facility types, including arterials in CBDs, arterials in urban areas, suburban arterials, rural multilane highways, two-lane highways, CBD signalized intersections, urban signalized intersections, suburban signalized intersections, CBD all-way stop-controlled intersections, urban all-way stop-controlled intersections, suburban all-way stopped intersections, and freeways. The default value recommended in the HCM 2000 for percent no-passing zones was based on the survey results.

Basic Freeway Segments

The basic freeway segment procedure developed under NCHRP Project 3-45 is based primarily on a large database (415 15-minute samples) representing 56 sites from across the United States. The recommended procedure consists of two components which are used to calculate travel speed and density. The first component is the same analytical model that is used to estimate hourly flow rate in the 1985 procedure, accounting for the variability of flow between 15-minute periods (i.e., PHF) and the influence of heavy vehicles in the traffic stream combined with the effects of grade on heavy vehicle performance. Passenger-car equivalencies, which are used to describe the affect of heavy vehicles on traffic flow, were developed from several sources. The passenger-car equivalencies included in the 1985 HCM for freeways and multilane highways were generated using a model that simulated the operation of different vehicle types on specific grades or terrains. The 1985 HCM included equivalencies representing three truck weight-to-horsepower classes and RVs. As part of the multilane highway research (NCHRP Project 3-33) heavy vehicles and RV equivalencies were updated using simulation and field data. The minimum equivalencies for trucks and RVs were developed from traffic flow data collected at two sites in California. In the 1994 HCM, the updated equivalencies were recommended for both multilane highways and freeways. Based on research conducted by Elefteriadou, lower heavy vehicle equivalencies were developed for HCM 2000.

The second component estimates the free-flow speed of the section based on roadway characteristics. Adjustments to a base free-flow speed are made for number of lanes, lane width, lateral clearance, and interchanges per mile. Although the research found no correlation between lane width and speed, the lane width adjustments developed from the multilane highway research were applied to freeways. The multilane highway research found a moderate correlation between lane width and speed.

28 Default Values for Highway Capacity and Level of Service Analyses

NCHRP Project 3-45 also looked at variation in the basic freeway segment speed-flow relationship between four metropolitan areas where data were collected. Four cities (San Diego, Sacramento, Seattle, and Des Moines) were compared. Statistical analysis of the data indicated that site location accounted for 42% of the variation in speed. Free-flow speeds observed at the four sites ranged from 58 to 65 mph. Although the comparison of traffic flow data was limited to four cities, the research suggested that this variation in the speed-flow relationship was due to a broad range of factors, including driver aggressiveness and level of enforcement.

AASHTO design guidelines for freeways in the United States are 12-ft lane width and 10-ft right-shoulder width. These recommendations were included in the HCM 2000 as default values.

NCHRP Project 3-45 recommended a 70-mph base free-flow speed for all types of freeways. After the national speed limit was raised, a 75-mph free-flow speed curve was added. The HCM 2000 recommends a 75-mph base free-flow speed for rural freeways and a 70-mph free-flow speed for urban freeways.

Ramps and Ramp Junctions

The 1994 HCM procedures for the analysis of freeway-ramp merge and diverge areas were developed by NCHRP Project 3-37. This research involved a rather extensive field study of some 68 sites in 10 states, generating 341 15-minute samples. The procedure consists of essentially two components: estimation of the volume in lanes 1 and 2 of the freeway and estimation of the average speed and density of traffic within the merge or diverge influence areas. A series of equations to estimate the volumes in the two lanes immediately adjacent to the ramp (lanes 1 and 2) were developed empirically for both merge and diverge influence areas. The equations were based on a consistently strong correlation between volume in lanes 1 and 2 with total freeway volume, regardless of the number of lanes. Depending upon the number of lanes and presence of upstream or downstream ramps, a predictive model was calibrated using field data. NCHRP Project 3-55(6) added a speed prediction model for the outside lanes of the freeway.

NCHRP Project 3-55(2)A included a broader range of acceleration and deceleration lane lengths than what is presented in the HCM 2000. The NCHRP Project 3-55(2) recommendations are provided in Table 9. These default values were calculated using AASHTO design standards for a 12-ft wide single-lane ramp, the tangent angle for exit ramps which ranges from 2 to 5%, and the taper rate for entry ramps which ranges from 50:1 to 60:1.

Transit

The transit variables, current defaults, and those input parameters that have the greatest impact on the results are provided in Table 10. Despite the absence of transit default values in the HCM 2000, the TCQSM provides default values for a number of variables. The TCQSM has gone through several updates since the publication of HCM 2000. Other transit-related default values in the HCM 2000 were recommended based on vast experience of transit operators and TCRP research agencies.

Table 9. Freeway ramps acceleration/deceleration lane lengths (NCHRP Project 3-55[2]A).

Area Type	Length of Acceleration Lanes (ft)	Length of Deceleration Lanes (ft)
CBD	650	165
Urban	650	165
Suburban	750	250
Rural	825	325

Table 10. Transit default values.

Variable	Description	Default Value	Comments
g/C	green time per cycle	0.30-0.70	TCQSM Part 4, Appendix D; NTI course on TCQSM provides more specific values based on functional class of major/minor streets; has sig. effect on results
t_d	dwelling time at busiest stop	15, 30, 60 s	TCQSM p. 4-4, based on stop environment; automatic vehicle location (AVL) data from different regions could be used to refine values; has sig. effect on results
bus stopping position	bus stops in travel lane or not	none given	off-line (out of travel lane) is typical for mixed-traffic, on-line (in travel lane) is typical for bus lanes
t_c	clearance time at busiest stop	10 s + re-entry delay	re-entry delay given by lookup table in TCQSM (Ex. 4-5), based on auto volume in curb lane; delay only applies to off-line stops
Z	failure rate	2.5%, 10% (range 2.5-25%)	TCQSM App. D, based on stop environment
c_v	coefficient of variation of dwell times	0.6 (range 0.4-0.8)	TCQSM p. 4-8
N_{el}	number of effective loading areas at the busiest stop	none given	prefer that the user input (has a sig. effect on the result), 1-2 is typical
bus stop location	Near-side vs. far-side	none given	near-side is typical & produces more conservative results
f_l	Bus-stop location factor	Lookup table	TCQSM Ex. 4-51, based on bus lane type and bus stop location
V_r	right-turning volume at busiest stop	none given	HCM Urban Streets chapter could provide guidance on the volume of traffic that makes the turn
	conflicting ped volume at busiest stop	none given	HCM Signalized Intersection chapter could provide guidance
C_r	capacity of right-turn movement at busiest stop	Lookup table	TCQSM Ex. 4-50, based on a simplification of the HCM Signalized Intersection method, uses g/C ratio & conflicting ped volume
f_k	skip-stop factor	none given	skip-stops are rarely used, 1 would be an appropriate default
PHF	passenger arrival PHF	0.75 or 0.85 (range 0.60-0.95)	TCQSM, p. 4-5, 0.75 applies to clock headways, 0.85 applies when headways are adjusted to help even out the passenger demand per bus
Pmax	maximum schedule load per bus	54-64	depends on bus size, agency policy (which in turn may depend on headways & city size), TCQSM p. 4-17 & Ex. 4-17 provide guidance
Stop frequency	number of bus stops per mile	none given	prefer that the user input (has a sig. effect on the result), can be based on block spacing or agency policy
Td	average dwell time	none given	has a sig. effect on the result; automatic vehicle location (AVL) data from different regions could be used to develop values
tr	base bus running time	Lookup table	TCQSM Ex. 4-56, based on stop frequency and average dwell time
Tl	base bus running time losses	Lookup table	TCQSM Ex. 4-57, based on facility type and traffic signals (typical, set for buses, signals more frequent than bus stops)
Fs	Stop pattern adjustment factor	none given	skip-stops are rarely used, 1 would be an appropriate default
Fb	Bus-bus interference factor	Lookup table	TCQSM Ex. 4-59, based on bus v/c ratio

User Survey Results

A user survey was conducted in November 2005 to determine the use of HCM default values as well as the source of alternate default values. The survey participants were identified from the following sources:

- Highway Capacity Analysis Package (HiCAP) software database
- Members and Friends of the Committee on Highway Capacity and Quality of Service
- The NCHRP Project 3-82 panel
- The database developed for the Highway Capacity Manual Applications Guide (HCMAG)

The survey distribution and responses are summarized by Category in Table 11.

The twenty-three state DOT representatives who responded included three from Florida, two each from Michigan and Virginia, and one each from California, Delaware, Idaho, Iowa, Kentucky, Maine, Maryland, Massachusetts, Montana, Nebraska, Nevada, North Dakota, Ohio, Oregon, Vermont, and Wisconsin.

The survey results were categorized by each HCM chapter and were summarized by the number of users relying on the HCM, other sources, or both for default values. Some observations from the survey results include the following:

- Default values found in the “General Traffic Characteristics” and “Signalized Intersection” chapters are most widely used.
- The least number of responses were found in the “Pedestrians,” “Bicycles,” and “Ramps & Ramp Junctions” chapters.
- A number of HCM default values in the “Signalized Intersections” chapter, such as length of analysis period, lost time, arrival type, unit extension, actuated control adjustment, upstream filtering adjustment factor, base saturation flow rate, lane utilization, and queue spacing are among the most widely used HCM default values.
- A high percentage of respondents indicated the use of field data for the following input parameters: directional distribution (42%), PHF (45%), cycle length (48%), %HV (44%), lane width (36%), and grade (34%).
- “One-hour” is the only length of analysis period used when the default value of “15 min” is not used.
- The most commonly used default values for PHF are 0.9 and 0.95.
- 2% and 5% are the most commonly used default values for %HV.
- The base free-flow speed values used most often are either the posted speed limit or 5 mph over the posted speed limit.
- AASHTO’s Greenbook and the respective DOT’s reference manuals are the main sources used to obtain other default values.

Table 11. Survey response.

Category	Number of Surveys Distributed	Number of Surveys Returned
Consultants	287	21
Federal Agencies	19	1
State Agencies	153	23
Local Agencies	79	2
University or Transportation Institutes	113	3
"No organization listed"	27	1
TOTAL	678	51

Recommended Default Values

Approximately one-third of the input parameters with an associated HCM default value have a significant impact on the point or facility service measure. In general, input parameters that describe the facility type, area type, terrain type, and geometric configuration (such as lane width, segment length, and interchange spacing) are readily available to the analyst. Default values should not be used for these input parameters. The remaining input parameters that are highly sensitive can be broken into two categories:

- Data can be obtained and the default value may be confirmed, updated, or defined further as a function of a range of variables such as region, city size, volume, and so forth. This chapter addresses these input parameters.
- Data are not readily available; however, guidance regarding the selection of an appropriate default value can be provided based on research contained in the literature. Chapter 4 addresses these input parameters.

The input parameters that have a significant impact on the service measure are summarized in Table 12. For each of these input parameters, either a revised set of default values is recommended (in Chapter 3) or guidance on the selection of appropriate input parameters is provided (in Chapter 4). Some input parameters that did not have a high degree of sensitivity are also addressed.

In addition to these input parameters, PHF and %HV were investigated for all uninterrupted and interrupted facilities. Despite low to moderate sensitivity results for two-lane and multilane highways, this type of data is readily available and the existing defaults were explored further. Although there are no default values provided for unsignalized intersections in HCM 2000, PHF and %HV were investigated for unsignalized intersections due to the impact that these input parameters could have on the level of service measure.

Defining Default Values by Category

As a result of insufficient field data, the HCM recommends that only a single default value be used for many key input parameters. Thus, the variation of traffic and geometric conditions across the United States is not considered. Each input parameter could potentially be described by environmental variables, such as metropolitan size or geographic region, to determine if driver behavior or local design practices impact the magnitude of the input parameter. There are eight independent variables that have been examined in the development of default values. These independent variables are categorized as global and non-global variables and are shown below in Table 13.

Table 12. Summary of input parameters with high sensitivity.

Input Parameter	Source for Default Value
Urban Streets	
Signal density (signals/mi)	Guidance provided in Chapter 4
Free-flow speed	Guidance provided in Chapter 4
Signalized Intersections	
PHF	Chapter 3
Length of analysis period (hr)	Use HCM Guidance
Arrival Type (AT)	Use HCM Guidance
Adjusted sat flow (veh/hr/ln)	See Base Saturation Flow
Base sat flow (pc/hr/ln)	See Chapter 3 for through lanes and Chapter 4 for exclusive left-turn lanes
Lane widths (ft)	Measure in the field or on plans
%HV	Chapter 3
Lane utilization (f_{LU})	See Chapter 3 for through lanes and Chapter 4 for exclusive left-turn lanes
Pedestrians	
Effective sidewalk width (ft)	Measure in the field or on plans
Street corner radius (ft)	Measure in the field or on plans
Pedestrian walking speed (ft/s)	Guidance provided in Chapter 4
Pedestrian start-up time (sec)	Guidance provided in Chapter 4
Bicycle Paths	
PHF	Use HCM Guidance
Bicycle speed (mph)	Use HCM Guidance
Multilane Highways	
%HV	Chapter 3
Base free-flow speed (mph)	Use HCM Guidance
PHF	Chapter 3
Two-Lane Highways	
Length of passing lanes (mi)	Observe in the field or measure on plans
%HV	Chapter 3
Basic Freeway Segments	
Driver population factor	Guidance provided in Chapter 4
Specific grade or general terrain	Observe in the field or measure on plans
%HV	Chapter 3
PHF	Chapter 3

Table 13. Environmental descriptors as candidate independent variables.

Category	Independent Variable	Comments
Global	Metropolitan Area Size	Population: > 1,500,000; 250,000 to 1,500,000; 50,000 to 250,000; < 50,000
	Geographic Region	Southwest, Southeast, Northwest, Midwest, Northeast
Non-Global	Functional Class	Freeway, Arterial, Collector, Local
	Terrain Type	Level, Rolling, Mountainous
	Segment Length	For a road segment (continuous)
	Traffic Lanes in Cross Section	1, 2, 3, 4
	Hourly Volume	Entering Volume (low, moderate, high)
	Time of Day	a.m., p.m., midday

If the intent were to describe the parameter by all of the eight variables, the database composition should reflect the following factorial design:

- × 4 metropolitan area sizes,
 - × 5 geographic regions,
 - × 4 functional classes,
 - × 3 terrain types,
 - × 4 lane combinations,
 - × 2 volume levels, and
 - × 3 time periods.
- = 5,760 total combinations

If each combination of independent variables (e.g., metro size 1, in geographic region 1, with a functional class 1, for terrain type 1, volume level 1, and lane configuration 1) was represented by only a single observation of the input parameter, there would be 5,760 total observations required. Preferably two or three observations for each input parameter would be required, resulting in the need for many more observations. Project resources cannot support this level of data need.

Rather than investigating combinations of independent variables, the global variables can be investigated independently or as a smaller subset of the possible combinations (e.g., metro size 1 in geographic region 1). This requires less data and enables some investigation of the possible relationships.

When defining the geographic regions, the 50 states, Washington, D.C., and Puerto Rico have been divided into five geographic regions:

- Southwest Region (8) California, Nevada, Utah, Arizona, Colorado, New Mexico, Hawaii, and Texas
- Southeast Region (12) Virginia, North Carolina, South Carolina, Georgia, Florida, Alabama, Louisiana, Kentucky, Tennessee, Mississippi, Puerto Rico, and Washington, D.C.
- Northwest Region (6) Washington, Oregon, Idaho, Montana, Wyoming, Alaska
- Northeast Region (12) New York, Maine, New Hampshire, Vermont, Massachusetts, Connecticut, Pennsylvania, New Jersey, West Virginia, Maryland, Delaware, Rhode Island
- Midwest Region (14) North Dakota, South Dakota, Nebraska, Kansas, Oklahoma, Minnesota, Iowa, Missouri, Arkansas, Wisconsin, Illinois, Indiana, Michigan, Ohio

These regions are shown in Figure 1.

When defining metropolitan area population sizes, U.S. Census Bureau data from the year 2000 census were reviewed. Communities were grouped together into metropolitan statistical areas (MSAs) so that metropolitan areas could be categorized by size. According to the U.S. Census Bureau, an MSA is a core area containing a substantial population nucleus, together with adjacent communities having a high degree of economic and social integration with that core. Each MSA must have at least one urbanized area of 50,000 or more inhabitants. (An MSA with a population of 1 million or more inhabitants is identified as a Consolidated MSA.) The following population thresholds were developed for the 280 MSAs:

- City Size 1—Greater than 1,500,000
- City Size 2—Between 250,000 and 1,500,000
- City Size 3—Between 50,000 and 250,000

An additional category, City Size 4, was added for city sizes less than 50,000. Metropolitan areas with populations greater than 50,000 are called urbanized areas. Metropolitan areas with population between 5,000 and 50,000 are called urban areas. Rural areas contain populations less than 5,000.



Figure 1. Geographic region boundaries.

Data Sources and Calculation Methodology

Sources for input parameter data were obtained from the following three categories:

1. Completed (or ongoing) research projects—NCHRP, FHWA, and state research efforts as well as published reports.
2. Governmental Agencies—Database sources in the governmental agency category included various count programs from federal, state, county, and city agencies.
3. “In-house” databases assembled from transportation projects.

Two types of data can be collected: explicit default values and raw data. Explicit default values are default values found in city, county, state, or federal sources that have been previously defined based on raw data. Raw data statistics are used to compute a mean default value for each “site.” A “site” is defined as an individual traffic movement served by the facility and for which a level of service can be computed using a methodology in the HCM.

A number of the default values have a basis that includes a temporal representation. These variables represent a traffic characteristic that includes the count of vehicles for a given unit of time (e.g., volume). In these instances, the basis for the variable is defined to be the time period that is associated with the peak hour of the average week day (PAW), where the peak hour is defined using the flow rate of vehicular traffic. Other time periods may be used as the basis for computation if the data in these alternative time periods are determined to be representative of the PAW. The peak hour (and in some cases the peak 15-min period) is recommended as the basis for defining default values because this time period is most commonly used for capacity and level-of-service analysis.

Table 14. Input parameter basis and weight.

Facility Type	Site Definition	Input Parameter	Desired Basis ^{1,2}	Weight ^{3,4}
Urban Street	One direction of travel on a segment	Free-flow Speed	Site	Vehicles
		Signal Density	Site	1
Signalized Intersection	One lane group on an intersection approach	PHF	PAW at a site	Vehicles
		%HV	Peak 15 min of PAW at a site	Vehicles
		Lost Time	PAW at a site	Cycles
		Arrival Type	PAW at a site	Vehicles
		Base Saturation Flow Rate	PAW at a site	Cycles
		Lane Utilization	Peak 15 min of PAW at a site	Vehicles
Unsignalized Intersection	One intersection movement	PHF	PAW at a site	Vehicles
		%HV	Peak 15 min of PAW at a site	Vehicles
Pedestrian Facility	One sidewalk or crosswalk	Walking Speed	Site	Pedestrians
		Start-up Time	Site	Pedestrians
Two-Lane Highway	One direction of travel on a segment	PHF	PAW at a site	Vehicles
Basic Freeway Segment	One direction of travel on a segment	%HV	Peak 15 min of PAW at a site	Vehicles
		PHF	PAW at a site	Vehicles
		Driver Population Factor	Site	Vehicles
		%HV	Peak 15 min of PAW at a site	Vehicles
Multilane Highway	One direction of travel on a segment	PHF	PAW at a site	Vehicles
		%HV	Peak 15 min of PAW at a site	Vehicles

1. Desired Basis: the basic unit for one observation of each study variable. For those variables that represent measurements over time, the time period is that associated with the peak hour of the average week day (PAW), as defined by vehicular traffic. Other time periods may be used if the data are determined to be representative of the PAW.
2. PAW: Peak hour of the average week day, as defined by vehicular traffic.
3. Weight: Variable that will be used to weigh the observation when combined with those from other sources.
4. Vehicles: the total number of vehicle observations used to quantify the mean for the corresponding study variable.

Table 14 summarizes each facility type, the site definition, input parameters with high sensitivity, the associated basis of the measures (e.g., temporal), and variable used to weight the means.

For most random variables, the mean value is the most representative value of the population. Moreover, the methodologies developed for the HCM were developed from databases that contained mean values as independent and dependent variables. In addition, the mode, median, and standard deviation were also computed and reported, where appropriate.

The remainder of this chapter presents recommended default values for the following:

- %HV for uninterrupted flow facilities
- PHFs for uninterrupted flow facilities
- %HV for interrupted flow facilities
- PHFs for interrupted flow facilities
- Base saturation flow rates for signalized intersections
- Lane utilization for through lanes at signalized intersections

%HV for Uninterrupted Flow Facilities

There are three types of uninterrupted flow facilities analyzed in the HCM: freeways; multilane highways (with signal spacing greater than 2 mi); and two-lane rural highways (also with signal spacing greater than 2 mi). The HCM defines heavy vehicles as those having “more than four tires touching the pavement.” This category of heavy vehicles includes trucks, buses, and recreational vehicles.

Data Sources

The most comprehensive data source for measurement of %HV is the HPMS annual data summary provided by the FHWA. HPMS data include several vehicle classes with four or more tires touching the pavement. Hence, these data are consistent with the HCM definition. Freeway, multilane highway, and two-lane highway data have been extracted from the HPMS using the following methodologies:

- **Freeways:** Data for freeways were extracted using the HPMS freeway functional classification. Data were removed when the functional classification did not conform to the HCM freeway definition (i.e., limited access, median-divided, presence of traffic signals, low speeds).
- **Multilane Highways:** Data for multilane highways were extracted based on the access classification and number of lane categories, including partial/no access control with a divided cross-section or full access control with an undivided cross-section. Although signals are permitted under the HCM definition for a multilane facility, signal spacing needs to be 2 mi or greater (equivalent to a signal density less than 0.5 signals per mile).
- **Two-lane Highways:** The HPMS two-lane highways data are defined as rural sections that have two through lanes of travel and two-way operation. This definition covers only those facilities located in areas with a population of less than 5,000. This is the rural category in the HPMS data. Most of these highways do not have full access control.

To negate concerns that the %HV data are from estimates rather than from field measurements, the frequency distribution of the observations for %HV within each state by facility type was examined. Where field measurements have been used, the distribution of values of %HV approximates a skewed normal distribution. Statewide estimates will tend to have only a few values of %HV. An example is illustrated in Figure 2. The data on the left chart represent data obtained from field measurements. The data on the right chart represent statewide estimates.

Where the state’s HPMS data have been estimated, the recommended default value was based on similar nearby states. When a mix of the actual and estimated %HV exists (evident in the distribution by a much larger than expected peak for a given %HV), the peak value was given a lower weight based on the adjacent %HV observations within the distribution.

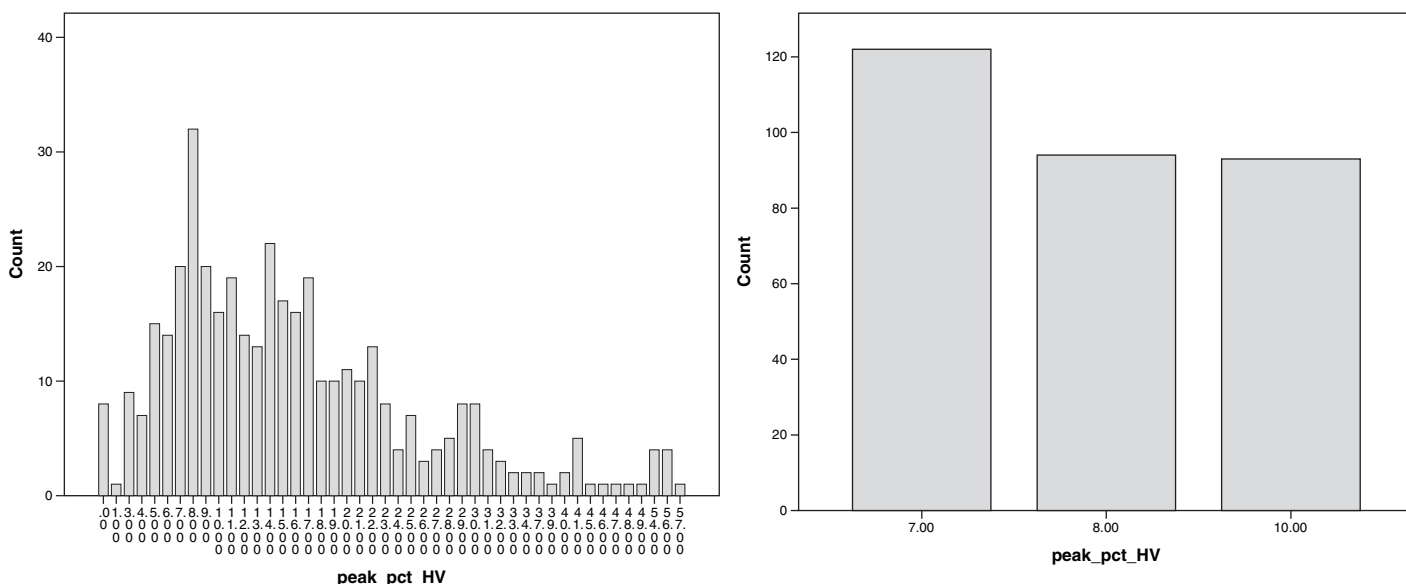

Figure 2. Example of HPMS %HV distributions for field and estimated data.

The data were also checked to confirm that the same values were not reported for both the peak period and the daily %HV. The difference between the two values was calculated. A zero difference was observed for Missouri, Montana, Nevada, North Carolina, South Dakota, Utah, and Wyoming. Zero differences were also observed for some road types in Idaho, Iowa, North Dakota, and Louisiana. Most of these states are rural in character without large urban areas. Further, all four non-freeway road types (and two freeway categories) are rural or are present in small urban areas. In these areas, peaking will not be very severe. Default values for these states were produced from a combination of their daily average %HV data and information on the average difference between peak period and average daily %HV for similar and/or nearby states in the HPMS database.

The data underlying the recommended default values were obtained from the Year 2004 HPMS database, the latest available at the time data collection for this project was undertaken. These values are reasonable for use in the intermediate-term future. If external conditions change, it may make sense to vary the default values from those that are provided here. For example, if gasoline becomes so expensive that auto drivers reduce their use of private cars, the %HV reported here may increase. In the absence of any major change, state and local agencies may wish to conduct a simple statistical analysis of their own HPMS data submissions every 5 years to determine if there has been a change in %HV.

Data Summary and Analysis

The HPMS data contain information on the state and population category for each section of roadway. Some states have a very large number of observations for a particular category, while other states have very few observations. Because of the size of this database, it is possible to test statistically whether regionalization is appropriate for %HV. Based on the analysis, statistically significant differences were observed in the mean peak period %HV among the states within each region and facility type. Given the consistent results of these analyses, the default values have been presented at the state level, rather than for each of the five geographic regions.

Recommended Default Values

Table 15 reports the mean peak period %HV by state for two-lane and multilane highways that occur within the lowest two population categories. The mean values in the table are presented to the nearest integer, since that is the level of precision of the data in the HPMS. Note that the mean values in this table represent averages over a wide range of actual observed values of %HV. In many instances, an analyst could develop a more refined value of %HV by considering such things as surrounding land uses (for example factories or warehouses at one extreme; solely residential at another).

Table 16 reports the mean, standard deviation, and number of observations for the peak period %HV on freeways in four population categories. All values in the table are presented to the nearest integer, since that is the level of precision of the data in the HPMS. In general, the mean value of %HV is the recommended default value in the absence of any other information. But, users are urged to consider the magnitude of the standard deviation as an indication of the spread of the data. Changes to the mean values can be considered based on knowledge of local conditions.

PHFs for Uninterrupted Flow Facilities

The HCM defines PHF as “a measure of traffic demand fluctuation within the peak hour” which can be computed by dividing the peak hourly volume by the hourly equivalent of the peak 15-min flow rate within that peak hour. For the uninterrupted flow data, PHFs were calculated

Table 15. Recommended default values for peak period %HV by state for two-lane and multilane highways in rural and small urban areas.

STATE		Two-lane Highways				Multilane Highways			
		pop < 5,000		5,000 < pop < 50,000		pop < 5,000		5,000 < pop < 50,000	
		Mean	N	Mean	N	Mean	N	Mean	N
Southwest	Arizona	9	316	11	118	9	32	9	16
	California	9	728	5	637	9	101	6	61
	Colorado	11	289	4	111	5	22	5	61
	Hawaii	3	198	3	121	2	4	2	24
	Nevada	17 ^b	244	5*	70	10*	20	6*	5
	New Mexico	17	503	7	126	23	100	12	71
	Texas	13	815	9	444	12	128	9	82
	Utah	20*	405	9*	89	22*	16	14*	50
Southeast	Alabama	6 ^a	299	6 ^a	160	4 ^a	61	6 ^a	38
	Florida	8	239	4	67	7	52	7	38
	Georgia	8 ^b	339	5 ^b	202	6 ^b	51	6 ^b	44
	Kentucky	16 ^a	431	6 ^a	317	9 ^a	54	6 ^a	39
	Louisiana	16*	239	10*	195	6 ^b	73	16	20
	Mississippi	14 ^a	323	5 ^a	286	6 ^b	88	6 ^a	61
	North Carolina	8 ^b	466	4 ^b	286	6 ^b	133	6 ^b	77
	South Carolina	8 ^b	309	5 ^b	241	6 ^b	93	6 ^b	66
	Tennessee	5	313	4 ^a	201	6	64	4	59
	Virginia	4	277	2	106	5	95	2	12
	Puerto Rico	5	495	5 ^b	322	5	26	6	12
Northwest	Alaska	10	212	2	66	6	3	3	9
	Idaho	12*	468	7*	208	16*	21	9*	4
	Montana	10*	548	4*	181	6*	8	3*	16
	Oregon	12	537	5	261	6	14	9	23
	Washington	15	517	8 ^a	234	10	27	7	13
	Wyoming	15*	398	6*	184	10*	3	9*	43
Midwest	Arkansas	14	335	7	257	11	14	12	19
	Illinois	8	202	5	197	8	18	6	19
	Indiana	10	385	6 ^a	351	12	103	10	52
	Iowa	4*	543	5*	228	5*	72	4*	47
	Kansas	15 ^a	475	3	237	12*	39	6*	47
	Michigan	9	354	7 ^a	214	8	5	4	14
	Minnesota	9	487	8 ^a	342	8	103	6	95
	Missouri	9*	376	6*	194	12 ^b	40	10*	19
	Nebraska	10	550	3	263	12	44	5	36
	North Dakota	14*	556	3*	214	12*	55	7*	18
	Ohio	11	466	4	368	14	106	9	57
	Oklahoma	14 ^a	556	5	423	17	95	11	131
	South Dakota	13*	468	4*	205	12*	49	7*	13
	Wisconsin	4	567	5 ^a	322	4	39	5 ^a	39
Northeast	Connecticut	3	141	3	94	2	1	6 ^b	2
	Delaware	7	115	6	99	9	44	8	32
	Maine	5	459	3	265	4	12	3	27
	Maryland	10	165	6	93	12	53	8	28
	Massachusetts	3 ^a	171	3 ^a	86	7 ^b	0	6 ^b	5
	New Hampshire	6 ^b	326	6 ^a	164	6 ^b	0	6 ^b	5
	New Jersey	8	96	7	55	8	5	6 ^b	2
	New York	8	294	5	276	8	21	5	31
	Pennsylvania	6	495	3	322	5	26	4	12
	Rhode Island	2	136	1	40	2	5	6 ^b	3
	Vermont	8	272	5 ^a	203	7	13	6 ^b	10
West Virginia	6 ^b	436	6 ^b	195	5 ^b	50	6 ^b	23	

* = The peak period %HV is identical to the daily average %HV for all or almost all observation in the HPMS data set for this cell. Default values have been estimated primarily from the daily average %HV for this cell, taking into account the results for other similar states in the same region, and in particular the difference between peak and daily average %HV in those states.

a = The reported values appear to be a mix of field observations and statewide values. The latter have been discounted, such that the average shown here is based primarily on the values deemed to be field observations with some consideration given to nearby states, and to the value the state thought was statewide.

b = Either there is insufficient field data, such that regional averages have been used, or there is not useable field data, either because there are in fact no data in the state for this road type, or because there is too heavy a reliance on statewide values for both the peak period and the daily average. In these cases, the default value has been estimated from field observations for nearby states.

Table 16. Default values for freeway peak period %HV by state.

STATE	<5,000			5,000- 50,000			50,000-250,000			>250,000		
	Mean	Std	N	Mean	Std	N	Mean	Std	N	Mean	Std	N
Southwest												
Arizona	21	8	420	19	10	51	18	9	38	11	6	206
California	16	8	173	10	6	86	7	4	86	6	5	566
Colorado	12	5	51	10	5	26	8	5	18	7	3	96
Hawaii	5	0	2	19 ^b	10 ^b	16	2	2	7	3	1	32
Nevada	34 ^b	9 ^b	69	26	13	47	18 ^b	9 ^b	2	11 ^b	6 ^b	125
New Mexico	26	13	71	12	6	119	21	11	13	12	9	29
Texas	16	8	168	28 [*]	6	23	8	4	186	5	3	545
Utah	34 [*]	9	161	--	--	--	18	2	17	13	6	106
Southeast (1), (2)												
Alabama	14 ^a	10	47	7	4	84	7	2	--	7 ^a	4	58
Dst of Columbia	--	--	--	--	--	--	--	--	--	4 ^b	3 ^b	--
Florida	11	3	69	7	4	84	12	6	--	6	3	330
Georgia	19 ^b	5 ^b	100	7 ^b	4 ^b	--	12	6	--	8 ^b	5 ^b	--
Kentucky	20 ^a	4	108	16	6	10	12	6	--	10 ^a	5	83
Louisiana	12 [*]	6	133	7 ^b	4 ^b	--	12	6	--	10 [*]	5 [*]	--
Mississippi	9 ^b	3 ^b	72	7 ^b	4 ^b	--	7	2	--	6 ^b	3 ^b	--
North Carolina	19 ^b	5 ^b	104	12 ^b	6 ^b	--	12	6	--	10 ^a	5 ^b	--
South Carolina	19 ^b	5 ^b	81	7 ^b	4 ^b	--	7	2	--	8 ^b	5 ^b	--
Tennessee	19	5	68	12	6	61	12	6	--	8	5	243
Virginia	9	4	54	7	4	84	7	2	--	4	3	158
Puerto Rico	6	1	12	7 ^b	4 ^b	--	7	2	--	4 ^b	3 ^b	--
Northwest												
Alaska	4	--	1	5 ^b	1 ^b	--	5	--	1	3 ^b	1 ^b	--
Idaho	29 [*]	6 ^b	--	28 ^b	7 ^b	--	12 ^b	3 ^b	--	7 ^b	4 ^b	--
Montana	22 [*]	6	161	16 [*]	7	37	12 [*]	3 [*]	27	NA	NA	--
Oregon	26	9	289	19	9	60	10	3	22	7	4	152
Washington	11	3	60	10	2	22	7	4	62	6	3	127
Wyoming	33 [*]	14	88	36 ^{*a}	17	39	28 [*]	14 [*]	31	NA	NA	--
Midwest												
Arkansas	30	12	91	24	14	55	13	8	53	14	9	67
Illinois	21	10	87	23	11	32	16	6	44	9	5	158
Indiana	26	7	105	25	6	21	23	11	19	14	7	94
Iowa	20 [*]	6	240	24 [*]	2	19	11 [*]	7	105	10 [*]	8 [*]	101
Kansas	21 [*]	8 [*]	78	17 [*]	5 [*]	36	8 [*]	3 [*]	35	9 ^b	7 ^b	--
Michigan	18	7	90	12	8	48	13	8	140	8	5	263
Minnesota	11	5	75	10	4	14	6	3	24	4	2	75
Missouri	29 ^b	11 ^b	--	23 ^b	11 ^b	--	13 ^b	6 ^b	--	10 ^b	5 ^b	--
Nebraska	36	14	48	37	6	10	11	0	6	8	9	43
North Dakota	21 [*]	6	83	22 [*]	3	10	10 [*]	4	26	NA	NA	--
Ohio	24	9	115	13	7	112	10	7	83	8	5	431
Oklahoma	28	8	217	27	11	105	12	2	20	10	5	228
South Dakota	20 [*]	5	133	14 [*]	4	25	9 [*]	4	34	NA	NA	--
Wisconsin	6	1	77	6	2	44	6	1	123	6	1	102
Northeast												
Connecticut	13	6	23	6	4	31	6	3	98	5	3	237
Delaware	NA	NA	--	NA	NA	--	9 ^b	4 ^b	--	8 ^b	4 ^b	--
Maine	5	2	178	5	2	36	5	2	87	NA	NA	--
Maryland	18	7	69	14	5	11	17	6	66	8	3	228
Massachusetts	7 ^a	5	43	5	4	11	4 ^a	2	24	4	2	463
New Hampshire	15 ^b	7 ^b	--	12 ^b	5 ^b	--	6 ^b	1 ^b	--	7 ^b	3 ^b	--
New Jersey	8	4	38	6	0	2	6	1	17	9	4	268

(continued on next page)

Table 16. (Continued).

STATE	<5,000			5,000- 50,000			50,000-250,000			>250,000		
	Mean	Std	N	Mean	Std	N	Mean	Std	N	Mean	Std	N
New York	18	5	106	11	4	83	11	4	114	7	4	269
Pennsylvania	16	6	1859	13	5	157	9	4	282	8	4	965
Rhode Island	3	1	12	NA	NA	--	NA	NA	--	4	2	41
Vermont	15	7	120	12	5	22	6	1	14	NA	NA	--
West Virginia	16 ^b	6 ^b	--	13 ^b	5 ^b	--	9 ^b	4 ^b	--	NA	NA	--

(1) Due to the small number of observations for population categories between 5,000 and 50,000 it was not possible to calculate individual values for many states. Based on the available information, separate defaults have been developed for two groups of states, as follows: AL, MS, SC, VA, PR and FL, GA, KY, LA, NC, TN.

(2) Data for the population category 50,000 to 250,000 for the states of AL, FL, and VA have been combined to obtain their values

* = The peak period %HV is identical to the daily average %HV for all or almost all observation in the HPMS data set for this cell. Default values have been estimated primarily from the daily average %HV for this cell, taking into account the results for other similar states in the same region, and in particular the difference between peak and daily average %HV in those states.

a = The reported values appear to be a mix of field observations and statewide values. The latter have been discounted, such that the average shown here is based primarily on the values deemed to be field observations with some consideration given to nearby states, and to the value the state thought was statewide.

b = Either there is insufficient field data, such that regional averages have been used, or there is not useable field data, either because there are in fact no data in the state for this road type, or because there is too heavy a reliance on statewide values for both the peak period and the daily average. In these cases, the default value has been estimated from field observations for nearby states.

Note that the WY distribution is bimodal, with one group centered on 19% and a second on 44%.

NA = not applicable. This population size does not exist in this jurisdiction.

for the three typical weekday peak periods: a.m., midday, and p.m. The peak hours were determined as the highest hourly volumes that occur within 2-hr periods including 7 to 9 a.m., 11 a.m. to 1 p.m. (midday), and 4 to 6 p.m. The highest peak 15-min period within the highest hours of these periods was used in the calculation of PHFs for each direction at the locations where data were available. The two-lane and multilane highway data represented in the uninterrupted flow data represent rural and urban areas (i.e., areas with a population less than 50,000).

Data Sources

Data for PHF estimation are actual traffic counts collected in 15-min intervals—primarily in 2006. Most data are typical weekday (i.e., Tuesday, Wednesday, or Thursday) counts during one or more of the peak periods. PHF data for uninterrupted flow facilities come from five sources: Caltrans, Florida DOT, Idaho DOT, Ohio DOT, and Wisconsin DOT. The sources are described below:

- California data include a total of 24 count sites in 13 cities. The observations contained freeway data which included 27 a.m. counts, 24 midday counts, and 26 p.m. counts. These counts were collected in spring 2006.
- Florida data include a total of 15 count sites in 15 cities. The observations contained two-lane highway, multilane highway, and freeway data which included 30 a.m. counts, 16 midday counts, and 30 p.m. counts collected at various times during 2005.
- Idaho data include 11 count sites in 7 cities. The observations contained two-lane highway, multilane highway, and freeway data which included 11 a.m. counts, 11 midday counts, and 11 p.m. counts collected in fall 2006.
- Wisconsin data include data from a freeway facility taken from 4 count sites. Observations included 44 a.m. counts, 40 midday counts, and 42 p.m. counts collected in the Milwaukee area during summer 2006.

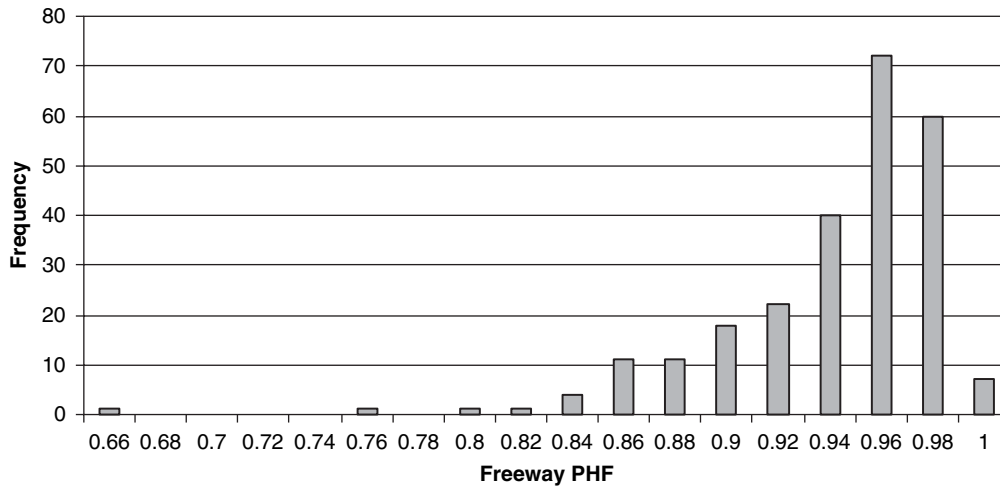

Figure 3. Frequency of freeway PHF.

The above data sources include one state from each geographic region with the exception of the northeast.

Data Summary and Analysis

Figure 3 illustrates the frequency of freeway PHF values. A total of 250 observations are included. The mean, median, and mode of the data are 0.94, 0.95, and 0.96, respectively. Removing the outliers has no effect on the mean.

Figure 4 illustrates the frequency of the multilane PHF values. A total of 24 observations are included. The mean, median, and mode of the data are 0.87, 0.89, and 0.92, respectively.

Figure 5 illustrates the frequency of the two-lane PHF values. A total of 93 observations are included. The mean, median, and mode of the data are 0.82, 0.85, and 0.90, respectively.

Table 17 provides a summary of the number of observations and the mean PHF by facility type, metro size, time of day, and volume. The multilane highway data are only available in the northwest region for a city size between 50,000 and 250,000 people. Similarly, the two-lane highway data are only available in the southeast, northwest, and midwest regions for a city size less than 50,000 people.

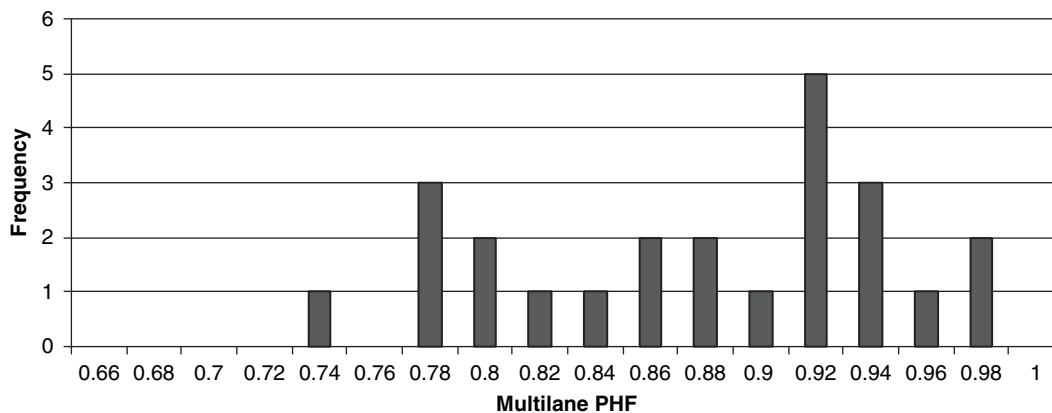

Figure 4. Frequency of multilane PHF.

42 Default Values for Highway Capacity and Level of Service Analyses

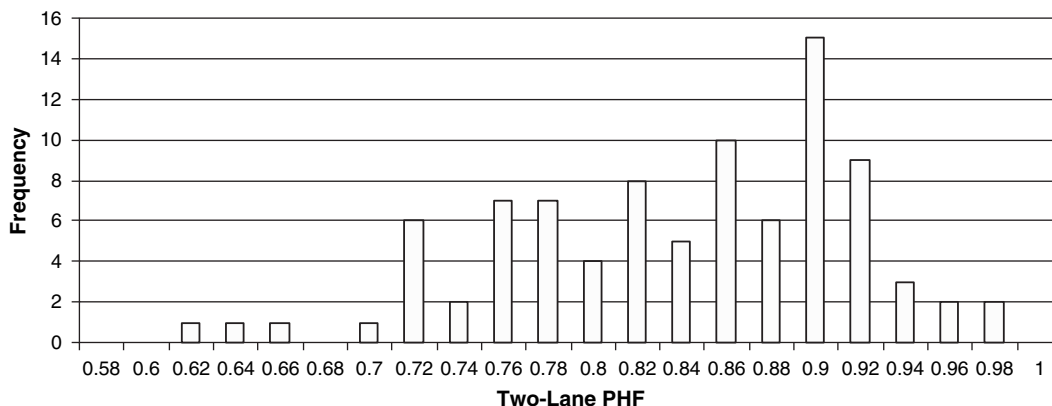

Figure 5. Frequency of two-lane PHF.

Given the limited amount of multilane and two-lane data, it is difficult to draw conclusions regarding mean PHF by region and city size. The freeway mean PHF is consistent across all regions. While the PHF appears to decrease with decreasing city size, there are few PHF observations for cities with less than 50,000 people.

In broad terms, the PHF is the highest for freeways, followed by multilane highways and then two-lane highways. There is a consistent trend in the data by time of day, with lower PHFs observed in the a.m. and higher PHFs observed in the p.m. There is also a consistent increase in the mean freeway PHF as the volume per hour per lane increases. This trend is not observed for multilane and two-lane highways, in part because of the lack of data. The type of facility and the time of day are correlated to volume. That is, a freeway typically carries more vehicles per lane than a multi-lane or two-lane highway. Hence, the PHF is higher. Similarly, the observed volumes associated with the a.m. peak period are typically less than the volumes associated with the p.m. peak period. Thus, the PHF is smaller. Furthermore, the a.m. and p.m. peak periods have different types of trips

Table 17. PHF by region, metro size, and time of day.

Description	Category	FREEWAY		MULTILANE		TWO-LANE	
		#Obs	Mean	#Obs	Mean	#Obs	Mean
Region	Southwest	77	0.93	0	NA	0	NA
	Southeast	28	0.94	0	NA	18	0.81
	Northwest	18	0.93	24	0.87	12	0.84
	Midwest	126	0.94	0	NA	63	0.83
	Northeast	NA	NA	0	NA	0	NA
City Size	>1.5M	39	0.94	0	NA	0	NA
	250K-1.5M	147	0.94	0	NA	0	NA
	50K-250K	60	0.93	24	0.87	0	NA
	<50K	3	0.90	0	NA	93	0.82
Period	AM	91	0.92	8	0.84	32	0.81
	MID	70	0.94	8	0.88	29	0.82
	PM	88	0.95	8	0.91	32	0.84
Hourly Volume /Lane	<500	19	0.89				
	501-1000	55	0.93				
	1001-1500	109	0.94				
	1501-2000	50	0.95				
	2001+	16	0.95				
Hourly Volume /Lane	<100			3	0.80	26	0.83
	101-200			3	0.93	31	0.81
	201-300			4	0.82	19	0.85
	301-400			8	0.88	7	0.86
	401+			6	0.91	10	0.77

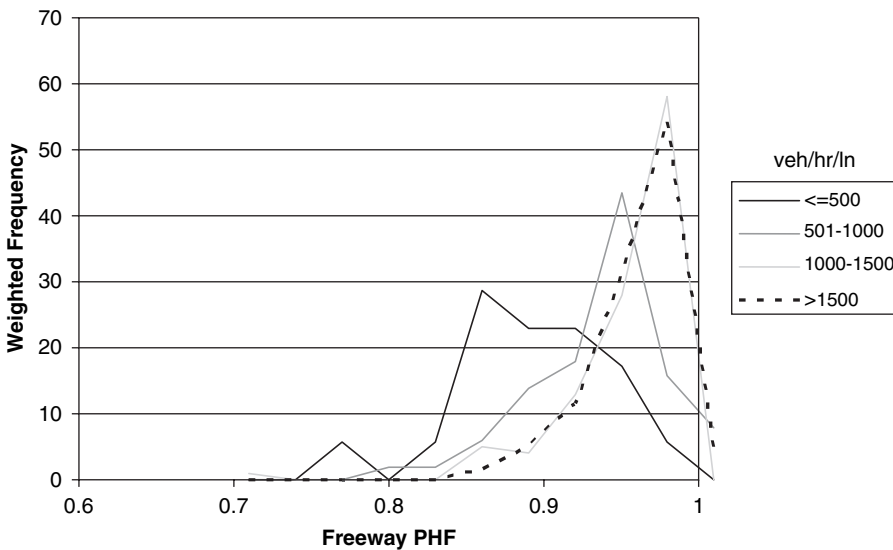

Figure 6. Weighted frequency of the freeway PHF for increasing volume bands.

which result in different peaking characteristics. The a.m. peak period primarily accommodates commuter trips, while the p.m. peak period accommodates different types of trips, including tourist, shopping, and school trips. Hence, the p.m. peak period traffic is more evenly spread over the hour, resulting in higher PHFs.

The weighted frequency for the PHF for each of the volume bands is illustrated in Figure 6. The spread and peak is visibly different, with the exception of the bands greater than 1,000 vehicles per hour per lane.

The recommended freeway PHF is 0.94; however, the user should be mindful of the relationship to volume and time of day discussed previously. A lower volume usually results in a lower PHF. The a.m. peak period PHF is typically lower than the p.m. peak period PHF.

The mean multilane and two-lane PHF values are 0.87 and 0.82, respectively. However, given the limited number of observations, no change from the current default value of 0.92 is recommended.

%HV for Interrupted Flow Facilities

The HCM defines heavy vehicles as those having “more than four tires touching the pavement.” This category includes trucks, buses, and recreational vehicles. The %HV was computed for each intersection approach and for all intersection approaches using peak-hour volumes. The peak hour is determined by first summing up the total entering volumes and then locating the highest sum for four consecutive 15-min periods. Once the peak hour is identified, the entering volumes and heavy vehicle volumes within the hour are computed. Approach %HV is computed by dividing the approach HV volume by the total approach volume. Similarly, the intersection %HV is computed by dividing the sum of HV volumes by the sum of total entering volumes.

Data Sources

The data for %HV were obtained from three sources: Wisconsin DOT; City of Kennewick, Washington DOT; and Quality Counts, Inc.

- Wisconsin data include 11 intersections in Milwaukee County. One intersection has two-way stop-control and the other ten intersections are signalized. All intersections have 12-hr count

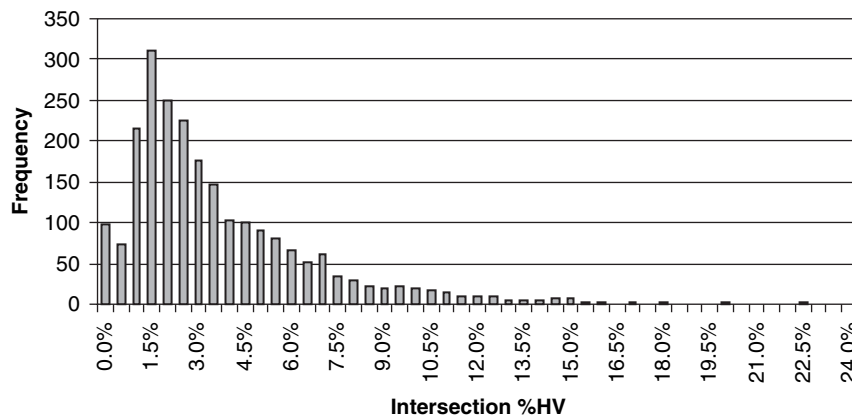

Figure 7. Frequency of intersection %HV.

data (6 a.m. to 6 p.m.) and include a state freeway or highway intersecting another state highway or local street.

- Kennewick, Washington, data include over 100 intersections within the city limits. While the majority of the intersections are signalized, there are also about 10 two-way stop-controlled and 7 all-way stop-controlled intersections. Count data are available for 2 hr each during the a.m., p.m., and/or midday periods.
- The majority of the data was obtained from the Quality Counts (QC) database. These data include over 2,000 observations at signalized and unsignalized intersections in Arizona, Idaho, California, Florida, Maryland, Oregon, Utah, and Washington. Each observation represents counts conducted during the a.m., p.m., or midday period.

Data Summary and Analysis

Figure 7 illustrates the frequency of the intersection %HV for signalized, all-way stop-controlled, and two-way stop-controlled intersection types. A total of 2,314 observations are included. Seven observations have greater %HV than illustrated, with two observations at 100%. The %HV mean, median, and mode of the data is 3.6%, 2.5%, and 1.5%, respectively. Removing the outliers results in a mean of 3.4%.

Figure 8 illustrates the frequency of the number of heavy vehicles for signalized, all-way stop-controlled, and two-way stop-controlled intersection types. The mean, median, and mode of the data are 52, 34, and 20 vehicles, respectively.

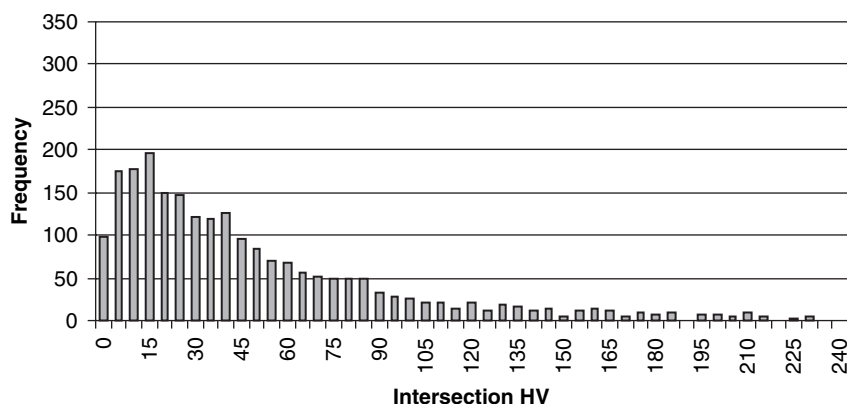

Figure 8. Frequency of number of heavy vehicles.

Table 18 provides a summary of the number of observations, mean %HV, and median %HV as a function of a number of discrete independent variables, including region, city size, intersection type, period (time of day), and approach volume.

Eighty-five percent of the data is represented in the northwest region. There are no observations in the northeast and few observations in the midwest. Fifty-five percent of the data is located in cities with greater than 1.5 million people. The %HV generally increases with a decrease in city size.

The data are well-represented for signalized intersections; however, little data are available for all-way stop-controlled intersections. Signalized intersection average %HV is lower than for the two-way stop-controlled and all-way stop-controlled intersections.

Approximately 50% of the %HV data was collected during the p.m. peak period. The peak period average %HV suggests that the time of day may have an influence on the mean %HV. That is, the a.m. peak period experiences a higher %HV than is experienced during other times of the day.

The number of observations is well-represented in each volume category. The mean %HV tends to decrease with decreasing total intersection volume. In most cases, the mean heavy vehicle percentage falls within a range of 2.5% to 3.5%.

Table 18. %HV by region, city, intersection control, peak period, and total intersection volume.

Description	Number of Observations	Mean %HV	Median %HV
REGION			
[1] Southwest	102	2.6%	1.7%
[2] Southeast	226	4.0%	2.6%
[3] Northwest	1949	3.6%	2.5%
[4] Midwest	33	2.8%	2.5%
[5] Northeast	0	NA	NA
TOTAL	2310		
CITY SIZE			
[1] >1.5M	1260	3.2%	2.1%
[2] 250K to 1.5M	262	3.5%	2.8%
[3] 50K to 250K	269	3.5%	2.8%
[4] <50K	519	4.6%	3.3%
TOTAL	2310		
INTERSECTION TYPE			
[A] AWSC	81	3.6%	2.1%
[S] SIGNALIZED	1645	3.4%	2.4%
[T] TWSC	588	4.0%	2.7%
TOTAL	2314		
PERIOD			
[AM]	697	5.1%	4.4%
[MID]	209	3.0%	1.4%
[PM]	1279	2.8%	1.9%
TOTAL	2185		
TOTAL VEHICLES			
500	385	4.1%	2.6%
1000	473	3.7%	2.7%
1500	428	3.6%	2.7%
2000	316	3.4%	2.5%
2500	243	3.2%	2.2%
>2500	468	2.7%	2.1%
TOTAL	2313		

AWSC: all-way stop-controlled

TWSC: two-way stop-controlled

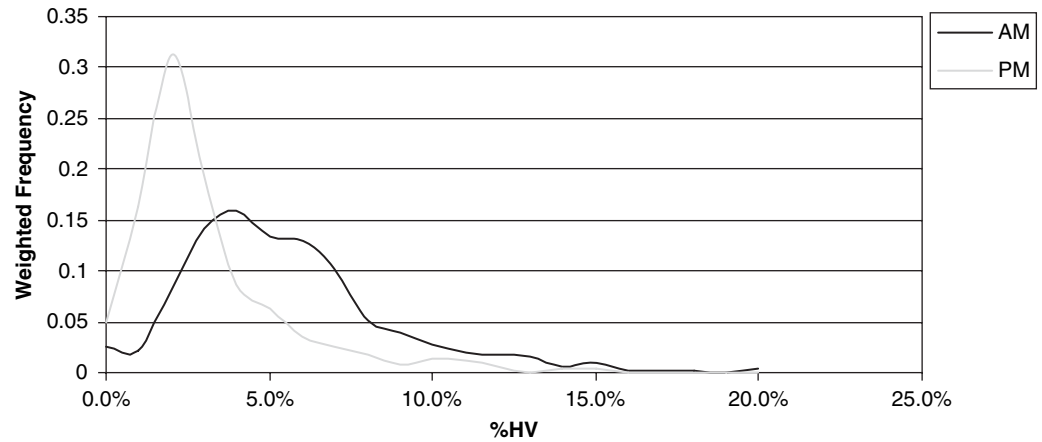

Figure 9. Weighted frequency of intersection %HV as a function of time period.

Figure 9 illustrates the %HV as a function of the time period. The frequency plots have been weighted by the number of observations for each comparison. The a.m. frequency plot is much flatter than the p.m. and also peaks at a lower %HV.

Figure 10 illustrates the difference in the %HV between the a.m. and p.m. peak periods at each intersection. The frequency is positive, indicating that the a.m. peak period is typically higher than the p.m. peak period %HV at each intersection location in the data.

Figure 11 illustrates the %HV as a function of the total intersection volume. At lower intersection volumes, there is much more variation in the %HV. This variation results in larger average %HV at lower volumes. For this reason, the median %HV is more stable than the mean.

Analysis of variance was used to quantify the effect of region, area population, control type, period, and intersection volume on the heavy vehicle volume. The coefficients are statistically significant; however, the resulting %HV prediction only varies between 0 and 5%. Given that the service measure of delay is sensitive for 15% HV or higher, the predicted variation in the %HV is not particularly valuable.

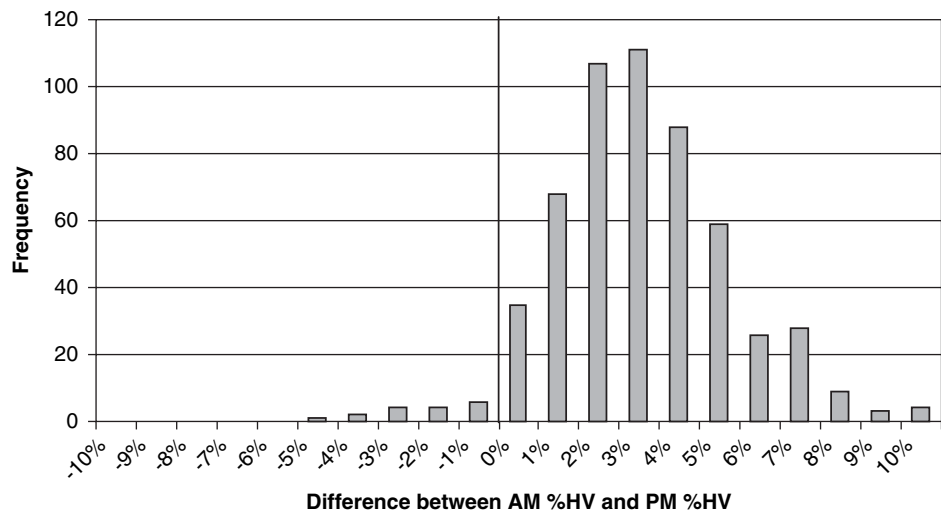

Figure 10. Frequency of the difference between the intersection %HV in the a.m. and p.m.

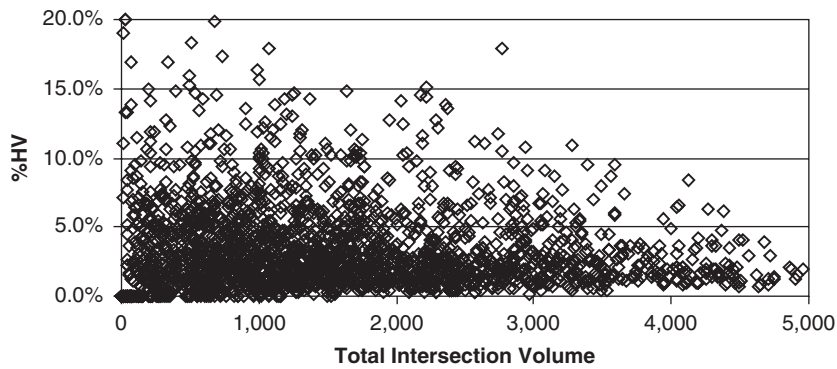

Figure 11. %HV as a function of total intersection volume.

Recommended Default Values

The recommended %HV is 3%, which is slightly higher than the current HCM default of 2%. The user should be aware of the relationship with volume, period, and city size, as indicated in the analysis above. As volume decreases, the %HV tends to increase. The %HV is typically lower during the a.m. peak period than during the p.m. peak period, and the %HV increases with decreasing city size.

PHFs for Interrupted Flow Facilities

The HCM defines PHF as “a measure of traffic demand fluctuation within the peak hour.” This can be computed by dividing the peak hourly volume by the peak 15-min flow rate within that peak hour. Because the existing definition in the HCM is general in nature, there are a number of different methods available to calculate PHFs at an intersection. Three popular methods are described as follows:

- Use the total entering volume to determine the peak 15-min interval and the peak hour. Subsequently, compute an overall intersection PHF. This approach yields the correct total volume during the peak 15-min time period, but may underestimate or overestimate the demands for the individual approaches and/or movements.
- Use the total approach volume to determine the peak 15-min interval and the peak hour. Subsequently, compute individual approach PHFs. Thus, a four-leg intersection would have four PHFs and a T-junction would have three PHFs. This approach, while used in practice (and perhaps encouraged by the HCM methodology), is fundamentally flawed in that it assumes that the individual approaches peak during the same time period, which rarely occurs. The result is a high likelihood of overestimating the total volume during the peak 15-min time period.
- Use the movement volume to determine the peak 15-min interval and the peak hour. Subsequently, compute individual movement PHFs. Thus, a four-leg intersection with left-through-right movements would have 12 PHFs. This approach is also fundamentally flawed in that it assumes that the individual movements peak during the same time period, which is extremely rare. The result is a very high likelihood of overestimating the total volume during the peak 15-min time period.

There are other variations of these methods. The total intersection volume method (the first method described above) is the only method that yields the correct total intersection flow rate. Calculating the approach or movement PHF assumes that each of the approaches or individual movements peak during the same time period, which is unlikely to occur.

Data Sources

Seven sources of useable PHF data were obtained. The seven sources are the Delaware DOT; Wisconsin DOT, the City of Kennewick, Washington; the City of Los Angeles; VRPA Technologies, Inc.; Tucson, Arizona; and Quality Counts, Inc. All data for PHF estimation were based on actual traffic counts collected in 15-min intervals—mostly in 2005 and 2006. Further, most data are typical weekday counts (i.e., Tuesday, Wednesday, or Thursday) that were conducted during one or more of the peak periods.

- Delaware DOT and Wisconsin DOT data were provided in MS Excel and PDF formats and included a number of intersections in various counties. All intersections have 12-hr count data (6 a.m. to 6 p.m.) in 15-min intervals and comprise of a state highway intersecting another state highway or local street.
- The City of Kennewick, Washington, provided data in PDF format for over 100 intersections within the city limits. While the majority of the intersections were signalized intersections, there were also ten two-way stop-controlled and seven all-way stop-controlled intersections. Count data were available for 2 hr each for the a.m., p.m., and/or midday periods in 15-min intervals.
- The largest data set was provided by the Quality Counts (QC) database. The data were provided in both PDF and MS Excel formats. The data comprised over 2,000 intersection counts at signalized and unsignalized intersections in Arizona, Idaho, California, Florida, Maryland, Oregon, Utah, and Washington. Each observation represented counts conducted during the a.m., p.m., or midday periods. The counts are typically in 5-min or 15-min intervals.
- The Pima Association of Governments (PAG) in Tucson, Arizona, provided data in MS Excel format at 16 major signalized intersections. All data were collected in spring 2006. Each intersection data set included 2 hr of 15-min counts for the a.m., midday, and p.m. peak periods.
- VRPA Technologies, Inc., provided data at eight intersections in Fresno, California; 10 intersections in Riverside, California; and 15 intersections in San Diego, California. The data were provided in MS Excel format and included both a.m. and p.m. peak counts in 15-min intervals.

Data Summary and Analysis

Figure 12 illustrates the frequency of the intersection PHF for signalized, two-way stop-controlled and all-way stop-controlled intersection types. The PHF mean, median, and mode of the data were found to be 0.89, 0.93, and 0.93 to 0.94, respectively. Removing the few outliers with PHF values of less than 0.70 resulted in a mean PHF of 0.90.

For planning purposes, the PHF for the major street volume was also calculated. As shown in Figure 13, the intersection PHF and major street PHF are heavily correlated. This could be helpful

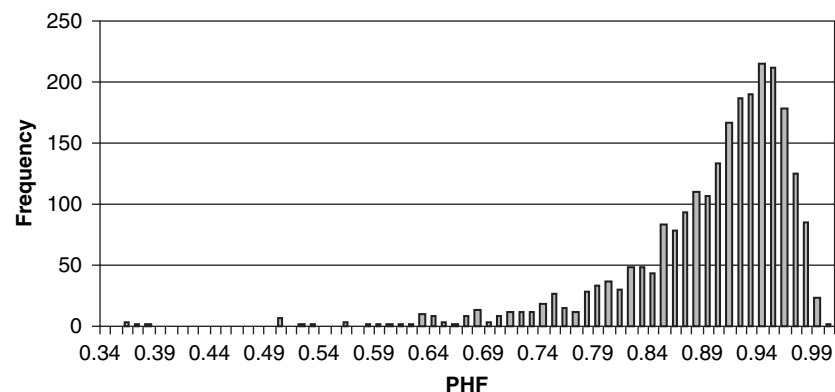

Figure 12. Frequency of intersection PHF.

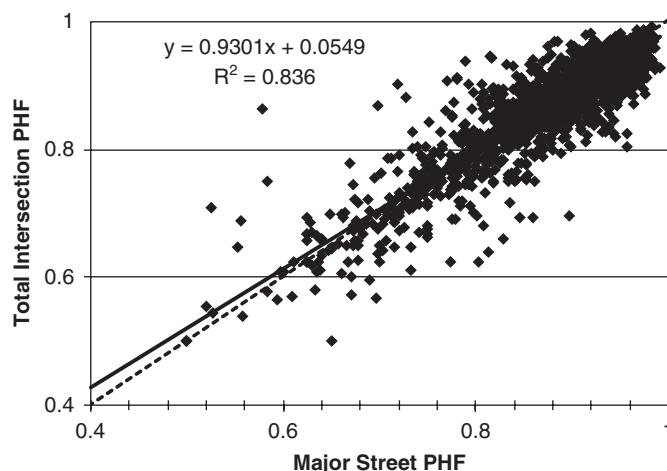

Figure 13. Intersection PHF as a function of major street PHF.

in situations where the user only had PHF data for the major street (based on tube count data for example).

Table 19 provides a summary of the number of observations, mean intersection PHF, and median PHF as a function of a number of discrete independent variables, including region, city size, intersection control, peak period (time of day) and volume. As indicated in the table, 78% of the data is represented in the northwest region. There are few observations in the northeast and midwest. Fifty-four percent of the data is located in cities with greater than 1.5 million people. Approximately 60% of the PHF data occurs in the p.m. peak period.

As indicated in Table 19, with the exception of the total intersection volume and time of day, most of the variables do not indicate any trend in the mean or median.

Figure 14 illustrates the intersection PHF as a function of total intersection volume. At lower total volumes, there is more variation in the PHF. This variation results in larger mean PHF at lower volumes. The median also indicates a similar trend. The median was found to be 0.93. Based on the results of the analysis, the current HCM default value of 0.92 appears to be reasonable when the total entering volume is greater than 1,000 vehicles. A more-conservative PHF (below 0.90) is likely to occur when the total entering volume is less than 1,000 vehicles.

Figure 15 illustrates the weighted frequency of the PHF for the a.m. and p.m. peak periods. The a.m. peak period has a greater spread and a lower peak PHF than the p.m. peak period. The a.m. and p.m. peak periods have different types of trips which result in different peaking characteristics. The a.m. peak period primarily consists of commuter trips, while the p.m. peak period contains different types of trips including tourist, shopping, and school trips. Hence, the p.m. peak period traffic is more evenly spread over the hour, resulting in higher PHF.

Recommended Default Values

Intersection PHF (rather than approach or movement PHF) has been used to determine the recommended PHF default value. The total intersection volume method is the only method that yields the correct total intersection volume. Approach or movement PHF assumes each of the approaches or individual movements peak during the same time period, which is unlikely to occur.

Based on the results of this analysis, the current HCM default value of 0.92 appears to be reasonable. The user should be aware of the relationship of PHF with volume and time of day. A

Table 19. PHF by region, city, intersection type, time period and volume.

Description	Number of Observations	Mean PHF	Median PHF
REGION			
Southwest	246	0.92	0.93
Southeast	226	0.91	0.92
Northwest	1949	0.88	0.90
Midwest	54	0.92	0.93
Northeast	28	0.89	0.90
CITY SIZE			
>1.5M	1340	0.89	0.91
250K-1.5M	334	0.90	0.92
50K-250K	269	0.89	0.90
<50K	550	0.88	0.90
INTERSECTION CONTROL			
AWSC	89	0.88	0.90
Signalized	1794	0.89	0.91
TWSC	618	0.87	0.89
TIME PERIOD			
AM	726	0.85	0.87
MID	232	0.92	0.94
PM	1362	0.90	0.92
TOTAL	2320		
TOTAL INTERSECTION VOLUME			
0-500	401	0.79	0.82
501-1000	498	0.87	0.89
1001-1500	452	0.90	0.91
1501-2000	338	0.91	0.92
2001-2500	259	0.92	0.93
>2500	559	0.93	0.94

AWSC: all-way stop-controlled
 TWSC: two-way stop-controlled

more-conservative PHF (below 0.90) is likely to occur when the total entering volume is less than 1,000 vehicles. Similarly the a.m. peak period PHF is likely to be lower than the p.m. peak period PHF.

In most cases, the major street PHF correlates with the intersection PHF. As such, the major street PHF can be used directly as an estimate of the intersection PHF, when the side street volumes are not readily available for planning applications.

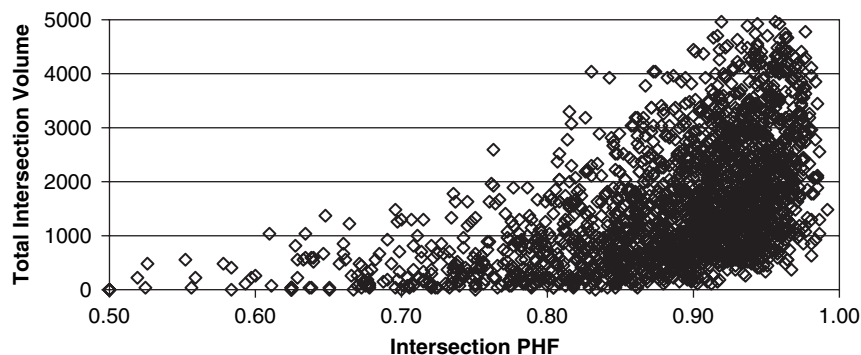

Figure 14. Intersection PHF as a function of total intersection volume.

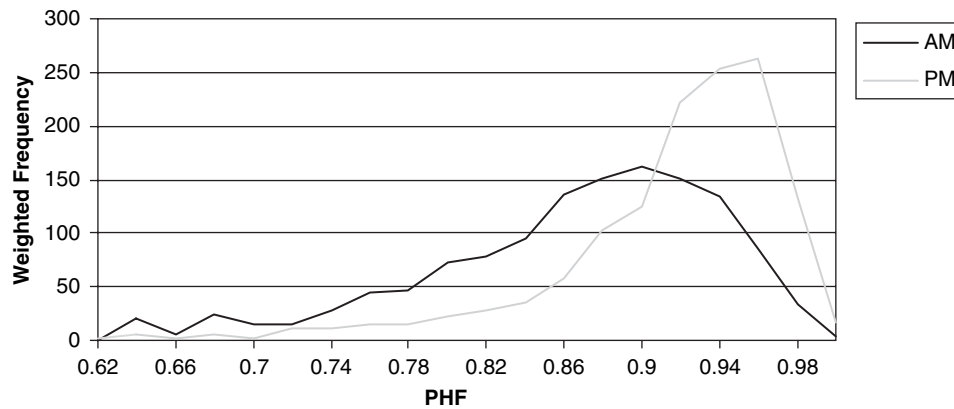

Figure 15. Intersection PHF as a function of time period.

Base Saturation Flow Rates for Signalized Intersections

The HCM defines saturation flow rate as “the equivalent hourly rate at which previously queued vehicles can traverse an intersection approach under prevailing conditions, assuming that the green signal is available at all times and no lost times are experienced.” The saturation flow rate can be estimated or measured in the field using procedures in the HCM. This research focuses on field data collected in accordance with HCM guidelines.

Data Sources

Government agencies do not typically collect saturation flow rate data as they do for PHF and %HV. A few agencies do collect the data, but because the collection methods do not strictly adhere to the HCM guidelines, their data cannot be used. The sources available for this analysis included NCHRP Project 3-72 research; FDOT research; field measurements in Tucson, Arizona; five communities in Oregon (Woodburn, Salem, Milwaukie, Tigard, and Albany); and published papers reporting findings in Maryland, Indiana, Texas, and Nevada. The following is a brief description of each source:

- The NCHRP Project 3-72 research collected saturation flow rates at 15 intersections in various parts of the county to study the effect of lane width on saturation flow rate.
- The FDOT research collected saturation flow rates at 33 intersection approaches in Florida to estimate the statewide base saturation flow rate. The research found relationships between saturation flow rate and area population, posted speed limit, number of lanes, and traffic pressure, in addition to other factors reported in HCM 2000. The research established an equation to estimate the base saturation rate for Florida.
- The Tucson, Arizona, data included data collected at eight intersection approaches in Tucson, Arizona.
- The Oregon data included data collected at seven intersection approaches in small to medium-size communities.
- Research findings on saturation flow rates have been reported for local conditions in Maryland, Indiana, Texas, and Nevada. Since cycle by cycle data are not available from this published research, direct comparisons with the above data sources are not appropriate; however, average saturation flow rates and the number of headway observations reported were considered useable data.

As indicated in Table 20, because the total number of saturation flow rate observations is low, dividing the data into bins to evaluate either regional differences or population size differences is inappropriate. No data were available from the Northeast region.

Table 20. Sample size by region, population size, and intersection type.

Region	Number of Observations
[1] Southwest	23
[2] Southeast	43
[3] Northwest	25
[4] Midwest	43
[5] Northeast	0
Population Size	
[1] >1.5M	58
[2] 250K to 1.5M	25
[3] 50K to 250K	28
[4] <50K	23

Data Summary and Analysis

Figure 16 illustrates the frequency of the base saturation flow for signalized intersections. A total of 124 observations are included. (The data represented base saturation flow rates without adjustments for lane width or other input parameters.) The mean, median and mode of the data are 1,850, 1,860 and 1,875 vehicles per hour of green (vphg) (pc/hr/ln). Removing data more than two standard deviations from the mean (2,190 and 1,510) results in a mean of 1,860 pc/hr/ln, which is within 2% of the current HCM default of 1,900 vphg. When the observed base saturation flow rate is weighted by the number of headway observations that make up the mean at each site, the resulting mean is 1,894 pc/hr/ln.

Table 21 provides a summary of the number of observations and the weighted mean, median, and the 95th percentile confidence limits as a function of region and city size. City sizes of less than 250,000 clearly have a lower mean base saturation flow rate than the two population groups above 250,000. The mean base saturation flow rates between the population groups less than 250,000 and greater than 250,000 are statistically different. Consolidating the data into two groups yields a mean of 1,900 pc/hr/ln for city sizes greater than 250,000 and a mean of 1,750 pc/hr/ln for city sizes less than 250,000.

Recommended Default Values

Recommended base saturation flow rate default values are provided in Table 22. The user should be aware that the saturation flow rates obtained in the southeast and northwest regions

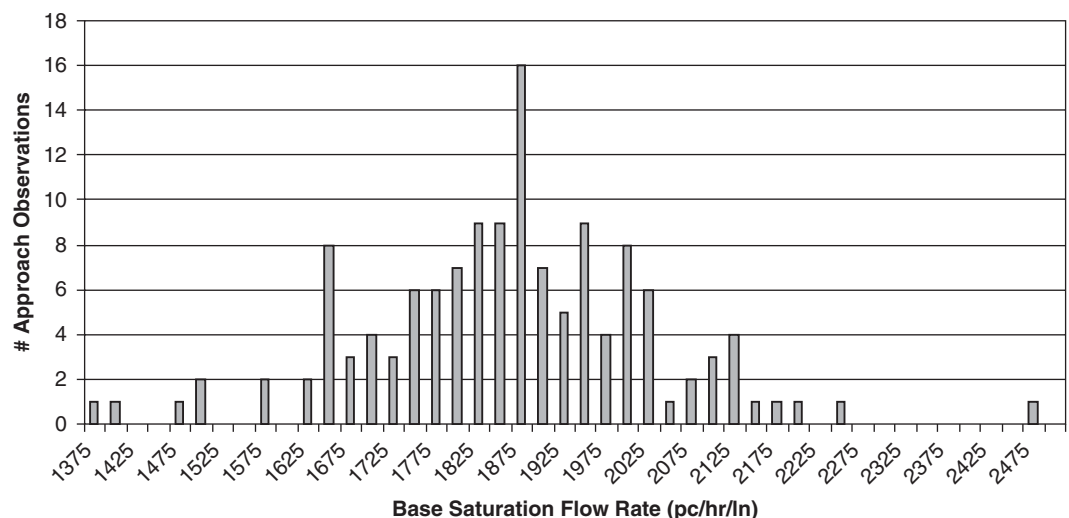

Figure 16. Frequency of the base saturation flow rate.

Table 21. Weighted base saturation flow by geographic region and city size.

Description	Number of Observations	Weighted Mean BSF	Median BSF	+/- 95th% Confidence Limits (1)
REGION				
Southwest	22	1923	1904	29
Southeast	38	1825	1817	36
Northwest	25	1822	1804	56
Midwest	39	1917	1971	40
Northeast	0	NA	NA	NA
TOTAL	124	1894	1860	
CITY SIZE				
>1.5M	55	1883	1865	27
250K to 1.5M	23	1913	1899	37
50K to 250K	25	1747	1688	40
<50K	21	1740	1738	40
TOTAL	124			

(1) The CL = $1.94 \cdot \text{STDEV} / \sqrt{N}$ of the weighted sample

Table 22. Recommended saturation flow rate by city size.

City Size	Median BSF
>250K	1900
<250K	1750

were lower. Effort should be made to confirm these regional differences in saturation flow rates, if data are available.

Lane Utilization for Through Lanes at Signalized Intersections

The HCM defines lane utilization as “the distribution of vehicles among lanes when two or more lanes are available for a movement.” The lane utilization adjustment factor can be computed by dividing the lane group volume by the number of lanes and highest lane volume in the lane group.

Data Sources

Data for lane utilization are not generally available. Three sources of data were available to the research team: the NCHRP Project 3-72 research, Quality Counts, Inc., and the FDOT saturation flow rate research. Altogether, 76 data points from 31 signalized intersections were obtained. Each data point represents lane volumes for one lane group configuration. The NCHRP Project 3-72 and Quality Count, Inc., data contain hourly lane volumes during a peak period, while only the number of vehicles per signal cycle could be derived from the FDOT saturation flow data. The data set was not of sufficient size to explore either regional or population size differences.

Data Summary and Analysis

Table 23 illustrates the mean and median lane utilization factor (f_{LU}), and the current HCM default values by lane group movement and number of lanes. Unlike the HCM, an additional lane group movement was added for the shared through right.

Table 23. Lane utilization by lane group and number of lanes.

Lane Group Movement	Number of Lanes in Group	Number of Intersections	Mean f_{LU}	Median f_{LU}	HCM Default f_{LU}
Through	2	33	0.95	0.96	0.95
	3	17	0.88	0.93	0.91
	4	0			
Shared Through	2	9	0.97	0.97	NA
	3	4	0.89	0.89	NA
Exclusive Left	2	4	0.85	0.86	0.97
	3	0			
Exclusive Right	2	0			0.89

There were no data available for lane groups with four through lanes, three exclusive left-turn lanes, or two exclusive right-turn lanes. (However, a literature review of lane utilization and saturation flow rate information for dual left-turn lanes and triple left-turn lanes is provided in Chapter 5 of this Guidebook.) For the two through lane group movement, there are 33 intersection observations. The mean f_{LU} is 0.95, which compares favorably to the current HCM default value. For three through lanes, the sample size was smaller and has fewer data points. The mean f_{LU} is lower than the current HCM default; however, the median is higher than the current HCM default value. There were two data points that were more than two standard deviations from the mean. Removal of these data points resulted in a mean f_{LU} of 0.91, which is the current HCM default value.

The two and three shared through lane group movements are very similar to the f_{LU} reported for the through lane group movements. The exclusive left turn f_{LU} is much lower than the value provided in the HCM. However, this factor is based on only four observations.

Recommended Default Values

Based on the results of the analysis of lane utilization factors, the current HCM default values for lane groups with two and three through lanes appear reasonable. No change is recommended to the current HCM default values. The left-turn data set was too small to make a finding regarding the validity of the current HCM default value.

Guidance for Selecting Defaults

This chapter provides information for input parameters where field data were not available. Default value guidance was developed based on a review of relevant research literature. This guidance is provided for six input parameters:

- Pedestrian walking speeds and start-up times at signalized intersections
- Lane utilization, traffic pressure, and distance between intersections for interchange ramp terminals
- Driver population factors on freeways
- Signal density on urban streets
- Free-flow speed on urban streets
- Saturation flow rates and lane utilization factors for dual and triple left-turn lanes at signalized intersections

Pedestrian Walking Speeds and Start-up Times at Signalized Intersections

Pedestrian walking speeds and start-up times are used in the analyses of signalized intersections, unsignalized (two-way stop-controlled) intersections, and pedestrian facilities—including walkways, shared off-street paths, crosswalks (signalized and unsignalized), and sidewalks along urban streets. There are a range of pedestrian walking speed values in the HCM, depending on the facility type to be analyzed. These walking speed values are described in Table 24. In general, a default pedestrian walking speed of 4 ft/s is provided, with the exception of the exclusive shared pedestrian and bicycle facilities, which assume a much faster walking speed of 5.0 ft/s. For exclusive pedestrian facilities where a mix of more than 20% elderly population is present, a default value of 3.3 ft/s is provided.

The source of the 4.0 ft/s default value for pedestrian walking speed is the Manual on Uniform Traffic Control Devices (MUTCD). This walking speed represents the 15th percentile pedestrian population. Therefore, it is intended to accommodate pedestrians who walk at speeds slower than the average. Pedestrian start-up times are used in the calculation of delay at a signalized intersection to determine the minimum pedestrian green time at crosswalks. The current HCM default value for pedestrian start-up time at an intersection is 3.2 s. Uninterrupted flow pedestrian facility service measures are highly sensitive to pedestrian walking speed. In addition, pedestrian walking speed is used extensively in the analysis of intersections. For these reasons, pedestrian walking speeds warrant further guidance.

Summary of Relevant Research

Several national publications were reviewed with respect to pedestrian walking speeds. A summary of the policy guidance from various sources on pedestrian walking speeds is provided in

Table 24. Summary of HCM 2000 pedestrian speed default parameters.

Facility Type	Sub Facility	LOS Measure	Parameter Impacting LOS That Uses Ped Speed	Comment	HCM 2000 Default Value
Signalized Intersections	Ped Signal	Vehicle Delay (s/veh)	Ped Adjustment Factor	Uses derivative of ped speed for Walk & Flash Don't Walk (FDW) Walk—4–7 (s) FDW—4–7 (s)	NA
	No Ped Signal	Vehicle Delay (s/veh)	Min Ped Green Time	Not directly used in the delay equation, but rather to ensure minimum green splits are met	4 ft/s
TWSC Intersections		Vehicle Delay (s/veh)	Ped Blockage Factor		4 ft/s
AWSC Intersections and Roundabouts:		Vehicle Delay (s/veh)	NA	Ped speed is not used	NA
Interrupted Ped Facilities	Signal	Time-space (ft ² /s)	Time-space		4 ft/s
	Unsignalized	Ped Delay (s/ped)	Critical Ped Gap	Example Problem uses 3 ft/s	4 ft/s
	Streets	Ave Ped Speed (ft/s)	Ave Ped Speed	Uninterrupted or interrupted; combines street segments and intersections	4 ft/s
Uninterrupted Exclusive Ped Facilities		Ave Ped Flow (ped/hr)	Ave Ped Flow	4 ft/s for a ped mix with up to 20% elderly (65 years+) 3.3 ft/s for a ped mix with an excess of 20% elderly	4 ft/s; 3.3 ft/s
Uninterrupted Shared Ped and Bike Facilities		# of Passing & Opposing Events	# of Passing & Opposing Events	Assumes an 8.0-ft wide path	5 ft/s

AWSC: all-way stop-controlled
 TWSC: two-way stop-controlled

Table 25. In the next edition of the MUTCD, a walking speed of 3.5 ft/s will be assumed for a signalized crosswalk when calculating the Flashing Don't Walk from the near side curb or shoulder to the far side of the traveled way or median of sufficient width for pedestrians to wait. The guidance will also include a separate calculation for the total pedestrian time (Walk plus Flashing Don't Walk) using a default walking speed of 3.0 ft/s from 6 ft behind the curb to the far side of the traveled way. (The distance of 6 ft behind the near side curb is assumed to represent the curb ramp length.) The Walk interval is calculated as the difference between the total pedestrian time and the Flashing Don't Walk interval. A minimum walk interval of 4 s still applies in this new procedure. The calculated times represent minimums needed to satisfy the assumed walking speed and crossing distance at a signalized crosswalk. The additional time that is required to satisfy pedestrian demand should be added to the pedestrian walk interval.

Table 26 provides examples of the total pedestrian time and the walk interval for various street widths plus an assumed ramp length of 6 ft. This pedestrian crossing time is based on the MUTCD adopted 3.0 ft/s walking speed used in total pedestrian time calculation and 3.5 ft/s speeds used in the Flashing Don't Walk calculation.

Table 27 summarizes recent pedestrian speed studies. As indicated, the pedestrian walking speeds vary between 2.8 ft/s and 4.0 ft/s. Elderly walking speed observations range from 2.8 to 3.5 ft/s. Although there is no universal value for pedestrian walking speeds, it is clear that the current HCM default value of 4.0 ft/s does not sufficiently accommodate elderly pedestrians.

Table 25. Summary of policy guidance on pedestrian speed research findings.

Reference		Walking Speeds	Source Guidance
1	DRAFT MUTCD	3.0 ft/s 3.5 ft/s	3.0 ft/s for a minimum FDW from curb to far side of the travel way or median sufficient to wait. 3.5 ft/s for a minimum Walk + FDW from 6' (ramp length) behind the curb to the far side of the travel way. A minimum Walk interval of 4 s applies.
2	Policy on Geometric Design of Highways and Streets	2.8 ft/s to 6.0 ft/s	Factors affecting walk speeds include age, steep grades, weather, time of day, and trip purpose. Age is the most common cause of slower speeds. 2.8 ft/s should be used where there are many older people.
3	Traffic Engineering Handbook	4.0 ft/s	Includes a summary of research indicating walking speeds are often slower than 4 ft/s.
-	Public Rights-of-Way Access Guidelines	3.0 ft/s	Draft recommendation for the calculation of signal timing.

1. Manual on Uniform Traffic Control Devices for Streets and Highways. Washington, DC, USA: FHWA, November 2003.
2. A Policy on Geometric Design of Highways and Streets. Washington, DC, USA, 2004.
3. *Traffic Engineering Handbook*. Fifth Edition. Washington, DC. Institute of Transportation Engineers (ITE), 1999.

Default Value Guidance

The current HCM default walking speed at an intersection is based on the MUTCD. The default value represents the 15th percentile pedestrian population and is intended to accommodate pedestrians who walk at slower than average speeds. Given that the MUTCD is decreasing the recommended walking speed from 4.0 ft/s to 3.5 ft/s, users of the HCM should consider a similar change for signal timing purposes. At a signal, the total pedestrian crossing time and associated components should be defined as follows:

- Total Pedestrian Time (Walk + Flashing Don't Walk) = 3.0 ft/s walking speed from 6 ft behind the curb to the far side of the traveled way or median of sufficient width for pedestrians to wait
- Pedestrian Clearance Time (Flashing Don't Walk) = 3.5 ft/s from curb to curb
- Walk interval = Total Pedestrian Time minus Pedestrian Clearance Time

Uninterrupted flow pedestrian facility level of service is highly sensitive to pedestrian walking speeds. The current HCM default value is 3.3 ft/s for a pedestrian mix with greater than

Table 26. Total pedestrian times based on 3.0 ft/s and top of ramp to curb crossing distance.

Street Width (ft)	Assumed Ramp Length (ft)	Total Crossing Distance (ft)	Total Ped Time ¹ (s)	FDW Interval ² (s)	Walk Interval (Total Ped Time–FDW) (s)
40	6	46	15.3	11.4	3.9 (4.0 s)
60	6	66	22.0	17.1	4.9
80	6	86	28.7	22.9	5.8
100	6	106	35.3	28.6	6.7
120	6	126	42.0	34.3	7.7

¹Based on 3.0 ft/s assumed walking speed in the MUTCD.

²Based on 3.5 ft/s assumed walking speed in the MUTCD from curb to curb.

Table 27. Summary of pedestrian speed studies.

Reference		Walking Speeds	Source Guidance
1	Fitzpatrick et al.	3.8 ft/s 3.5 ft/s	Year 2005 data from 42 sites in seven states; 3.8 ft/s 15th percentile walking speeds <60 years of age 3.5 ft/s 15th percentile walking speeds > 60 years of age or less able
2	Gates et al.	2.9 ft/s to 3.8 ft/s	Year 2005 data from 11 sites 2.9 ft/s for locations with 100% peds > 65 years of age 3.6, 3.5, 3.4, 3.3 ft/s for 20, 30, 40, and 50% mix of peds > 65 years of age
3	Knoblauch et al.	4.0 ft/s 3.1 ft/s	4.0 ft/s 15th percentile speeds for peds < 65 years of age 3.1 ft/s 15th percentile speeds for peds > 65 years of age
4	Staplin et al.	2.8 ft/s	Older pedestrians

1. Fitzpatrick, K., Brewer, M.A., and Turner, S. Another Look at Pedestrian Walking Speed. 85th Annual Meeting of the Transportation Research Board, CD-ROM. November 2005.
2. Gates, T.J., Noyce, D.A., Bill A.R., and Van Ee, N. Recommended Walking Speeds for Pedestrian Clearance Timing Based on Pedestrian Characteristics. 85th Annual Meeting of the Transportation Research Board, CD-ROM. November 2005.
3. Knoblauch, R.L., Pietrucha, M.T., and Nitzburg, M. Field Studies of Pedestrian Walking Speed and Start-Up Time. *Transportation Research Record No. 1538* (1996): 27-38.
4. Staplin, L., Lococo, K., Byington, S., and Harkey, D. Guidelines and Recommendations to Accommodate Older Drivers and Pedestrians. FHWA. *Publication No. FHWA-RD-01-051*. May 2001.

20% elderly. Given the range of speeds collected for elderly pedestrians (between 2.8 and 3.5 ft/s), the use of 3.3 ft/s is a reasonable value where there is limited data regarding the proportion of elderly pedestrians. For shared uninterrupted pedestrian-bicycle facilities, the HCM default value is 5.0 ft/s. Because the literature does not specifically examine these types of facilities, care should be taken in the consideration of the user's age, the facility grades, and trip purpose.

Interchange Ramp Terminals

A new version of Chapter 26 of the HCM (Interchange Ramp Terminals) has been approved by the Committee on Highway Capacity and Quality of Service. A methodology for conducting both operations and planning analyses for at-grade intersections (interchange ramp terminals) in the vicinity of freeway interchanges is now provided. This new chapter addresses diamond interchanges, PARCLOs, and single-point urban interchanges. The operations assessment relies on specific traffic and interchange information. The level of service is then calculated for each of the movements at the interchange, based on the total average control delay. The analysis of interchange ramp terminals requires the adjustment of a base saturation flow rate similar to the adjustment that occurs for signalized intersections. At interchange ramp terminals, different adjustments for traffic pressure and lane utilization at the external arterial approaches are determined. In addition, most interchange ramp terminal analyses involve the presence of two closely spaced intersections. The distance separating these two intersections is also a critical consideration in the operational analysis. Since the remaining input parameters for interchange ramp terminals are similar to the input parameter for an individual signalized intersection, the specific input parameters of interest for interchange ramp terminals include

- Lane utilization (external approaches only),
- Traffic pressure, and
- Distance between intersections within interchange.

Lane Utilization

At interchange ramp terminals, the lane utilization adjustment factors are calculated in the same manner as at an individual signalized intersection with the exception of the external arterial approaches. On the external arterial approaches, vehicles do not distribute as evenly among lanes in a lane group as at signalized intersections. Factors contributing to the unequal traffic distribution at the external arterial approaches include high turning movements at the downstream intersection and short internal link distances within the interchange. An example of this is the high volume of vehicles moving into the left lanes at an upstream intersection of an interchange to prepare for a left turn at the downstream intersection.

To account for this, models were developed to estimate percent of total flow in the external arterial approach lanes. The input data required for these models include:

- Interchange type
- Number of external arterial approach lanes (2, 3, or 4 lanes), and
- Origin-destination (O-D) demands from the external arterial approaches through the interchange (veh/hr).

To simplify calculation of the lane utilization factor of an external arterial approach to a particular interchange type, lookup tables were developed during the research project that led to the new Interchange Ramp Terminal chapter. These tables include several origin-destination movement distributions for each interchange type's exterior arterial approaches and the resulting lane utilization adjustment factors for 2-lane, 3-lane, and 4-lane approaches. (The only configuration not included in these tables is for the case of the diamond interchange with 2-lane arterial approaches. The lane utilization factor for this configuration requires the distance between intersections within the interchange.) These lookup tables have been simplified to facilitate their use. These simplified tables are provided in Appendix B of this Guidebook.

Traffic Pressure Adjustment Factor

Traffic pressure is used to adjust the ideal saturation flow rate in interchange ramp terminal analyses. This input parameter reflects the display of aggressive driving behavior by a large number of drivers during high-demand traffic conditions when shorter than usual headways are accepted during queue discharge. The traffic pressure for various demand flow rates and movement types are illustrated in Table 28 and Table 29. The demand flow rates are expressed in vehicles per cycle per hour (vpcph). Interchange turning movement counts are more typically expressed as vehicles per hour per movement. Therefore, these tables were developed to relate approach counts (vph) and demand flow rates by movement type and several cycle lengths (80 s, 100 s, 120 s, 140 s, and 160 s). The demand flow rates include a minimum of 1 vpcph to a maximum of 30 vpcph. The effects of demand flow rates greater than 30 vpcph are not known and the use of 30 vpcph should be used when analyzing higher flow rates.

As shown in these tables, demand flow rates of 14 vpcph or less result in traffic pressure adjustment factors less than 1.0 for through or right-turn movements. For left-turn movements, demand flow rates of 10 vpcph or less result in traffic pressure adjustment factors less than 1.0. Thus, it can be concluded that demand flow rates at or below these levels reduce the saturation flow rate while greater levels (i.e., shorter headways) increase the saturation flow rate.

Distance between Two Intersections within an Interchange

One of the primary geometric input parameters in the analysis of interchange ramp terminals is the distance between intersections within the interchange. This information is typically easy to

Table 28. Traffic pressure adjustment factor for various cycle lengths of demand flow rates (2-, 3-, and 4-lane approaches).

Demand Flow Rate, v_i	Cycle Length (sec)					Cycle Length (sec)					Cycle Length (sec)					Traffic Pressure Adj. Factor, f_p
	80	100	120	140	160	80	100	120	140	160	80	100	120	140	160	
	2-Lane Approach Volumes					3-Lane Approach Volumes					4-Lane Approach Volumes					
	vpcpl	vph	vph	vph	vph	vph	vph	vph	vph	vph	vph	vph	vph	vph	vph	
1	90	72	60	51	45	135	108	90	77	68	180	144	120	103	90	0.939
2	180	144	120	103	90	270	216	180	154	135	360	288	240	206	180	0.943
3	270	216	180	154	135	405	324	270	231	203	540	432	360	309	270	0.947
4	360	288	240	206	180	540	432	360	309	270	720	576	480	411	360	0.952
5	450	360	300	257	225	675	540	450	386	338	900	720	600	514	450	0.956
6	540	432	360	309	270	810	648	540	463	405	1,080	864	720	617	540	0.961
7	630	504	420	360	315	945	756	630	540	473	1,260	1,008	840	720	630	0.965
8	720	576	480	411	360	1,080	864	720	617	540	1,440	1,152	960	823	720	0.970
9	810	648	540	463	405	1,215	972	810	694	608	1,620	1,296	1,080	926	810	0.974
10	900	720	600	514	450	1,350	1,080	900	771	675	1,800	1,440	1,200	1,029	900	0.979
11	990	792	660	566	495	1,485	1,188	990	849	743	1,980	1,584	1,320	1,131	990	0.984
12	1,080	864	720	617	540	1,620	1,296	1,080	926	810	2,160	1,728	1,440	1,234	1,080	0.988
13	1,170	936	780	669	585	1,755	1,404	1,170	1,003	878	2,340	1,872	1,560	1,337	1,170	0.993
14	1,260	1,008	840	720	630	1,890	1,512	1,260	1,080	945	2,520	2,016	1,680	1,440	1,260	0.998
15	1,350	1,080	900	771	675	2,025	1,620	1,350	1,157	1,013	2,700	2,160	1,800	1,543	1,350	1.003
16	1,440	1,152	960	823	720	2,160	1,728	1,440	1,234	1,080	2,880	2,304	1,920	1,646	1,440	1.008
17	1,530	1,224	1,020	874	765	2,295	1,836	1,530	1,311	1,148	3,060	2,448	2,040	1,749	1,530	1.013
18	1,620	1,296	1,080	926	810	2,430	1,944	1,620	1,389	1,215	3,240	2,592	2,160	1,851	1,620	1.018
19	1,710	1,368	1,140	977	855	2,565	2,052	1,710	1,466	1,283	3,420	2,736	2,280	1,954	1,710	1.023
20	1,800	1,440	1,200	1,029	900	2,700	2,160	1,800	1,543	1,350	3,600	2,880	2,400	2,057	1,800	1.028
21	1,890	1,512	1,260	1,080	945	2,835	2,268	1,890	1,620	1,418	3,780	3,024	2,520	2,160	1,890	1.033
22	1,980	1,584	1,320	1,131	990	2,970	2,376	1,980	1,697	1,485	3,960	3,168	2,640	2,263	1,980	1.038
23	2,070	1,656	1,380	1,183	1,035	3,105	2,484	2,070	1,774	1,563	4,140	3,312	2,760	2,366	2,070	1.044
24	2,160	1,728	1,440	1,234	1,080	3,240	2,592	2,160	1,851	1,620	4,320	3,456	2,880	2,469	2,160	1.049
25	2,250	1,800	1,500	1,286	1,125	3,375	2,700	2,250	1,929	1,688	4,500	3,600	3,000	2,571	2,250	1.054
26	2,340	1,872	1,560	1,337	1,170	3,510	2,808	2,340	2,006	1,755	4,680	3,744	3,120	2,674	2,340	1.060
27	2,430	1,944	1,620	1,389	1,215	3,645	2,916	2,430	2,083	1,823	4,860	3,888	3,240	2,777	2,430	1.065
28	2,520	2,016	1,680	1,440	1,260	3,780	3,024	2,520	2,160	1,890	5,040	4,032	3,360	2,880	2,520	1.071
29	2,610	2,088	1,740	1,491	1,305	3,915	3,132	2,610	2,237	1,958	5,220	4,176	3,480	2,983	2,610	1.076
30	2,700	2,160	1,800	1,543	1,350	4,050	3,240	2,700	2,314	2,025	5,400	4,320	3,600	3,086	2,700	1.082

obtain for existing interchanges from sources such as field measurements, as-built drawings, or scaled aerial photos. For analysis of future interchange conditions, the distance between inter-sections can be estimated from conceptual plans or from construction documents. For operational and planning level analyses when exact distances are not known, the typical ranges by interchange type shown in Table 30 should be considered. (The source for the distance ranges shown on this table does not include the PARCLO AB interchange type.)

Default Value Guidance

This section has provided guidance for estimating three input parameters for the new version of Chapter 26 of the HCM. These values include two saturation flow rate adjustment factors (lane utilization and traffic pressure) as well as the distance between interchange ramp terminal inter-sections. The guidance for determining default values for purposes of conducting an analysis of interchange ramp terminals are provided below.

Lane Utilization

For existing conditions analyses (in the absence of local data) or for future conditions analysis:

- A default lane utilization factor of 1.0 is recommended for all lane groups at the interchange with the exception of the external arterial approaches.

Table 29. Traffic pressure adjustment factor for various cycle lengths of demand flow rates (exclusive left- and right-turn lanes).

Demand Flow Rate, v_i	Cycle Length (sec)					Traffic Pressure Adj. Factor, f_i
	80	100	120	140	160	
	Approach Volumes					
vpcpl	vph	vph	vph	vph	vph	
1	45	36	30	26	23	0.940
2	90	72	60	51	45	0.946
3	135	108	90	77	68	0.953
4	180	144	120	103	90	0.959
5	225	180	150	129	113	0.965
6	270	216	180	154	135	0.971
7	315	252	210	180	158	0.978
8	360	288	240	206	180	0.984
9	405	324	270	231	203	0.991
10	450	360	300	257	225	0.997
11	495	396	330	283	248	1.004
12	540	432	360	309	270	1.011
13	585	468	390	334	293	1.018
14	630	504	420	360	315	1.025
15	675	540	450	386	338	1.032
16	720	576	480	411	360	1.039
17	765	612	510	437	383	1.046
18	810	648	540	463	405	1.054
19	855	684	570	489	428	1.061
20	900	720	600	514	450	1.069
21	945	756	630	540	473	1.077
22	990	792	660	566	495	1.084
23	1,035	828	690	591	518	1.092
24	1,080	864	720	617	540	1.100
25	1,125	900	750	643	563	1.109
26	1,170	936	780	669	585	1.117
27	1,215	972	810	694	608	1.125
28	1,260	1,008	840	720	630	1.134
29	1,305	1,044	870	746	653	1.143
30	1,350	1,080	900	771	675	1.152

Demand Flow Rate, v_i	Cycle Length (sec)					Traffic Pressure Adj. Factor, f_i
	80	100	120	140	160	
	Approach Volumes					
vpcpl	vph	vph	vph	vph	vph	
1	45	36	30	26	23	0.939
2	90	72	60	51	45	0.943
3	135	108	90	77	68	0.947
4	180	144	120	103	90	0.952
5	225	180	150	129	113	0.956
6	270	216	180	154	135	0.961
7	315	252	210	180	158	0.965
8	360	288	240	206	180	0.970
9	405	324	270	231	203	0.974
10	450	360	300	257	225	0.979
11	495	396	330	283	248	0.984
12	540	432	360	309	270	0.988
13	585	468	390	334	293	0.993
14	630	504	420	360	315	0.998
15	675	540	450	386	338	1.003
16	720	576	480	411	360	1.008
17	765	612	510	437	383	1.013
18	810	648	540	463	405	1.018
19	855	684	570	489	428	1.023
20	900	720	600	514	450	1.028
21	945	756	630	540	473	1.033
22	990	792	660	566	495	1.038
23	1,035	828	690	591	518	1.044
24	1,080	864	720	617	540	1.049
25	1,125	900	750	643	563	1.054
26	1,170	936	780	669	585	1.060
27	1,215	972	810	694	608	1.065
28	1,260	1,008	840	720	630	1.071
29	1,305	1,044	870	746	653	1.076
30	1,350	1,080	900	771	675	1.082

- For diamond interchanges having 2-lane external arterial approaches, use the guidance provided in the new version of Chapter 26 with field-measured distances between intersections and O-D demand movements.
- For all other external arterial approaches, use the tables provided in Appendix B to determine the lane utilization factors based on O-D demand volumes.

Traffic Pressure

The equation for traffic pressure requires some knowledge of the existing or forecasted traffic volumes for a particular movement type. (Guidance for conducting traffic forecasts are typically provided by individual state DOTs.) Traffic pressure also requires knowledge of the cycle length at

Table 30. Ranges of intersection separation distances (ft) by interchange type.

Diamond Interchange			PARCLO A	PARCLO B
Conventional	Compressed	Tight Urban	2 or 4 Quadrants	2 or 4 Quadrants
900–1,300	600–800	200–400	700–1,000	1,000–1,400

Source: TRB Circular, Interchange Ramp Terminals, Tables 26-30.

which the interchange currently operates or at which the interchange is projected to operate. Since these variables vary by location, use of a single default value is not appropriate. The following guidance is provided:

- Select the traffic pressure factor from Table 28 and Table 29 based on existing or forecasted traffic conditions (volumes and cycle lengths).
- For lane groups with several movement types in a lane group, estimate the adjustment factor for traffic pressure as the weighted average of the respective turning movements (based on respective flows).

Distance between Two Intersections within an Interchange

The distance between intersections within an interchange is a factor used in the background of many of the input data values in interchange ramp terminal analyses. For diamond interchanges, this distance is dependent on factors such as the grade-separated roadway's design speed, number of lanes, grade, and vertical curvature. In the case of the PARCLO-type interchanges, the distance between intersections will largely depend on the radii of the loop ramps. Distance is a critical geometric input value in the analysis of interchange ramp terminals. In existing conditions analyses, actual distances should be used. During the interchange selection process in future conditions analyses, this distance should be obtained from scaled drawings of the various interchange configurations under consideration. If this information is not available, the values provided in Table 30 can be considered.

Driver Population Factors on Freeways

In the HCM freeway segment analysis procedures, an adjustment can be made for drivers who use freeways less efficiently. The HCM states that “whereas data are sparse and reported results vary substantially, significantly lower capacities have been reported on weekends, particularly in recreational areas¹. The adjustment factor f_p is used to reflect this effect. The values of f_p range from 0.85 to 1.00. In general, the analyst should select 1.00, which reflects commuter traffic (i.e., familiar users), unless there is sufficient evidence that a lower value should be applied. Where greater accuracy is needed, comparative field studies of commuter and recreational traffic flow and speeds are recommended.”

Summary of Relevant Research

According to Al-Kaisy and Hall, after the release of the 1985 HCM, Sharma and colleagues (1986, 1987) tried to provide guidance that would help the analyst estimate the driver population adjustment factor on the basis of the two extreme populations (i.e., commuters and highly recreational). Their approach was to develop a method for classifying roadways in terms of the composition of driver types in traffic; however, the driver population adjustment factors developed were based on the writers' “expert” opinion and the range of values provided by the 1985 HCM.

There are very few studies available that can assist in providing driver population factor guidance. A summary of two studies is provided below:

1. Al-Kaisy and Hall (2001) presented a methodology based on the ratio of the freeway capacity during the weekday a.m. peak period (a commuter dominated travel period) and a second time period (such as the p.m. peak period) that typically contained non-commuter and recreational

¹Tourist routes refer to roads used primarily by infrequent visitors, such as freeways leading to some of the western National Parks. The term does not include freeways to or in resort areas where most drivers are regular users of the road.

traffic. Capacity data caused by a construction zone were observed over several days. These observations indicated that the a.m. peak period has 7% more capacity than the p.m. peak period and 15% more capacity than the weekend peak period. A summary of 11 days of data is provided in Table 31.

2. Lu, Mierzejewski, Huang, and Cleland (1997) developed driver population factors on the basis of speed-flow data collected near Orlando, Florida. They also obtained estimates from the Office of Tourism Research of the Florida Department of Commerce of the non-local driver population. This work has two issues for current purposes:
 - The non-local driver index (DI) requires knowledge of the amount of non-local drivers. Non-local drivers are not the only kind of drivers that can produce a driver population factor of less than 1.0. Recreational drivers, shoppers, and other kinds of local drivers also result in lower capacities than a traffic stream of regular commuters.
 - The paper does not address capacity. The approach suggests that for the same set of drivers, the driver population factor is different depending on the service volume one is considering. This makes estimation of a driver population factor difficult.

Method for Estimating Local Driver Population Factors

On the basis of this literature search, the following describes the procedure for estimating local values of the driver population factor. This procedure is based primarily on the methods used by Al-Kaisy and Hall (2001). It assumes a freeway management system with regularly spaced detector stations, but can be used in any situation where it is possible to obtain traffic counts downstream of (uninterrupted flow) queuing, and speeds or occupancy values within the queue. The method is based on a comparison of (1) the value of capacity observed when regular commuters are using the road with (2) the capacity observed when there is a different driver population using it. Of course, knowledge of the freeway system is required to determine when different driver populations are likely to use the freeway system.

Consequently, it is necessary first to specify the locations at which one can be certain of seeing capacity. The four step procedure is described below.

Step 1. Identify location(s) that experience capacity operations in the a.m. peak and also at other times of the day or week.

Figure 17 shows a typical bottleneck location on a freeway. At location A, as traffic demand increases on both the mainline and the entrance ramp, stop-and-go traffic develops, which represents a queue of drivers waiting to use the bottleneck at location B. ‘Bottleneck’ in this sense

Table 31. Eleven days of observed capacities.

Day	Mean Capacity AM Peak (pcphpl)	Mean Capacity PM peak (pcphpl)	Driver Population Factor: ratio of PM/AM capacities
1	1982	1829	0.922
2	2064	1952	0.945
3	2057	1937	0.941
4	1866	1775	0.950
5	2066	1856	0.898
6	1723	1634	0.947
7	1961	1773	0.904
8	1926	1824	0.947
9	2001	1809	0.904
10	2022	1811	0.895
11	1970	1906	0.967
Mean	1967	1828	0.929

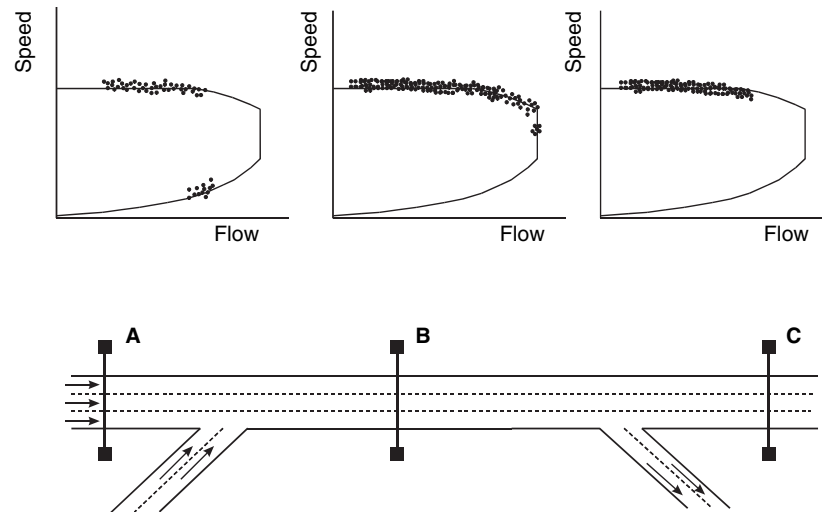

Figure 17. Measurement of capacity.

means a part of the roadway system with lower capacity than the upstream segment(s) feeding it. The bottleneck can be caused by an entrance ramp, as in Figure 17, or by a lane drop, or by the merger of two separate roadways. The location of interest for capacity measurement is within the bottleneck at location B, not within the queue at location A. The presence of the queue simply ensures that there is sufficient demand to be sure that the flow observed in the bottleneck is capacity flow, and not some lower number. Neither location A nor location C is likely to experience capacity operations. Flow at location A is lower than that at location B by the amount of traffic entering on the ramp. Flow at location C is lower than that at location B by the amount of traffic that has exited on the next ramp. Only at location B can capacity be observed, as indicated by the data points on the very end of the curve. Depending on how far downstream location B is from the end of the entrance ramp, these data points will occur at a lower speed than normal uncongested speeds, because the drivers are accelerating away from the front end of the slow-and-go queue. The exact location of point B between the entrance and exit ramps will not affect the measurement of flow rates, but is likely to affect the speed measurements.

To be certain of observing capacity operation at location B, there needs to be a queue at location A and regular uncongested operation at location C. The queue at location A ensures the presence of sufficient demand to provide capacity operation at location B. The absence of congestion at location C ensures that there is no congestion further downstream that would lead the flow rate at location B to be constrained by anything other than its own capacity.

Step 2. Measure the a.m. peak period capacity.

As Lu et al. note, even in their study area near Orlando, Florida, the weekday traffic from 5 a.m. to 8 a.m. consists of almost entirely commuters. Capacity during this time frame represents a driver population factor of 1.0, associated with a set of drivers who know the road very well and who will not be distracted by considerations other than the road and traffic.

Step 3. Measure the capacity at the other time of interest.

This measurement could occur during the afternoon peak period, to identify the effect of shopping traffic. Conversely, it could occur on the weekend to identify the effect of recreational or shopping traffic. It could also occur after a major event, to identify the effect of those drivers on roadway capacity. The objective is to measure the queue discharge flow rate at location B during the times when there is a queue present at location A, and not at location C.

Step 4. Calculate the ratio of capacity at this time of interest to the a.m. commuter capacity.

The resulting value (ratio of capacity at the off-peak time versus the capacity during the a.m. peak period) is the driver population factor for the specific subgroup who is using the road at the off-peak time: shoppers, recreational travelers, sports fans, and so forth. Note that one can also use different times of year (as Lu et al. did) to reflect varying tourist or other driver types of local concern. All that is necessary is to be able to identify times when a section of the road is at capacity and compare that with the capacity observed for commuter traffic.

The data reported in Al-Kaisy and Hall show that these capacity numbers will vary, even for the same driver population. Capacity is not a fixed value, but a random variable with a mean and a variance. If the data are obtained from permanent counting stations (as on a freeway management system), it should be a relatively simple matter to obtain similar data from a number of days and take the average over those days. If a special-purpose counting station is used, it may be more difficult to obtain several days of estimates. Even in that case, the queuing (and capacity operation) may continue for several hours. In this case, taking the average over the entire time period will be more useful than taking one 15-min observation. Taking a greater number of observations (or taking observations during a longer duration of time) results in a smaller variance in the estimate of the mean capacity and a better estimate of the driver population factor.

Default Value Guidance

In general, HCM analyses should assume that the driver population factor is equal to 1.0. A lower value should be used only when there are special circumstances, such as sporting events or tourist routes. Tourist routes refer to roads used primarily by infrequent visitors, such as freeways leading to some of the western National Parks. The term does not include freeways to or in resort areas where most drivers are regular users of the road.

Signal Density on Urban Streets

Signal density is simply a calculation of the number of signals divided by the length (measured in miles) on an urban street that is to be evaluated. The primary purpose for calculating signal density is to help the user determine the appropriate urban street class (Class I through Class IV). Exhibit 10-4 found in Chapter 10 of HCM 2000 provides a number of criteria to help the user determine the most appropriate urban street class. Signal density is one of the eight criteria. The signal density criterion found in HCM 2000 Exhibit 10-4 is summarized in Table 32.

Table 33 summarizes the default values provided in HCM 2000 Exhibit 10-6. The HCM suggests the default values may be used in the absence of local data. The project team believes that this recommendation is inappropriate given how sensitive the primary service measure for urban streets (average travel speed) is to signal density. The range of signal density provided in Table 32 can quite easily produce a three to four letter grade change in level of service. Further, a default value for signal density is typically not required since the number of signals on the facility to be studied is either known or can be easily determined.

Table 32. Summary of signal density criteria.

<i>Urban Street Class</i>	<i>Range of Signal Density (signals/mi)</i>
I	0.5-2
II	1-5
III	4-10
IV	6-12

Table 33. Signal density default values.

<i>Urban Street Class</i>	<i>Default Values (signals/mi)</i>
I	0.8
II	3
III	6
IV	10

Default Value Guidance

It is recommended that no default value for signal density be provided in future editions of the HCM. In situations where the number of signals along a facility is not known (potentially for long-range planning applications), it is recommended that the following guidance be used:

If the number of signals per mile is not known for a given planning application, it is recommended that the analyst first conduct a planning level assessment using a tool such as Exhibit 10-15 in HCM 2000 (see Figure 18) to determine which intersections along the urban street are likely to warrant signals.

Free-Flow Speed on Urban Streets

This section of the Guidebook describes a procedure for estimating the free-flow speed of an urban street. It is divided into four parts. The first part reviews current guidance contained in the HCM on free-flow speed. The second part summarizes research related to the free-flow speed for urban streets. The third part describes a procedure for estimating free-flow speed. The fourth part provides guidance for estimating free-flow speed. Much of the work described herein is a prod-

EXHIBIT 10-15. INTERSECTION CONTROL TYPE AND PEAK-HOUR VOLUMES
(SEE FOOTNOTE FOR ASSUMED VALUES)

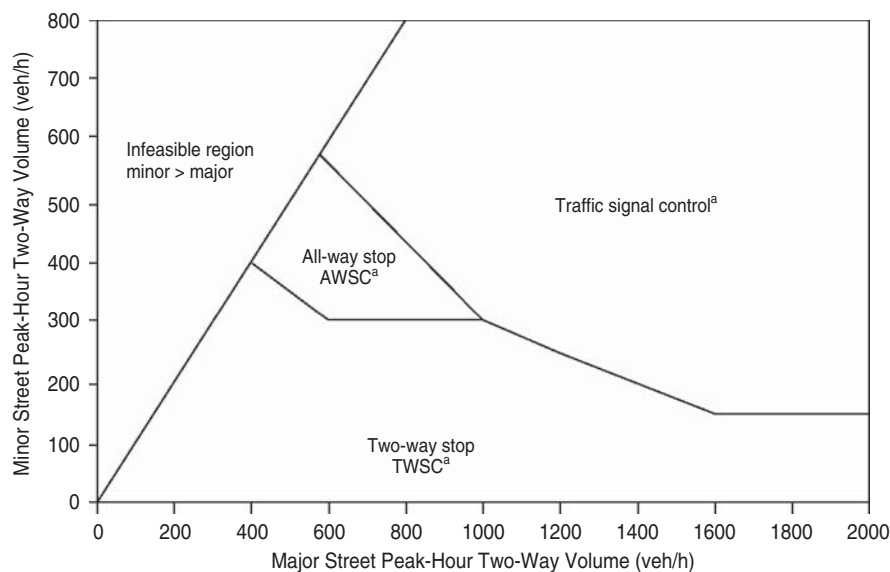

Notes

a. Roundabouts may be appropriate within a portion of these ranges.
Source: Adapted from *Traffic Control Devices Handbook* (8, pp. 4–18) - peak-direction, 8-h warrants converted to two-way peak-hour volumes assuming ADT equals twice the 8-h volume and peak hour is 10 percent of daily. Two-way volumes assumed to be 150 percent of peak-direction volume.

Figure 18. Intersection control type and peak-hour volumes.

uct of NCHRP Project 3-79 that developed an improved methodology for estimating travel speeds on urban streets. The improved methodology for estimating free-flow speed has some significant implications on the current HCM 2000 methodology.

Current HCM Guidance on Free-Flow Speed

Free-flow speed is defined in Chapter 10 of the HCM to be the speed that a through automobile driver travels under low-volume conditions along an urban street when all the signals are green for the entire trip. Low-volume is defined as a flow rate of 200 veh/hr/ln or less. This speed is not influenced by delay due to traffic control signals or signs.

The free-flow speed is a fundamental input parameter to the HCM methodology. It dictates the determination of running time and level of service. Guidance in the methodology indicates that this parameter can be based on direct field measurement or on a subjective determination of the street's class. This determination is based on a subjective evaluation of the criteria shown in Exhibits 10-3 and 10-4 in the HCM, shown herein as Table 34. Free-flow speeds by urban street class and speed thresholds for each level of service are shown in Table 35.

Table 34. Criteria considered to determine urban street class.

EXHIBIT 10-3. URBAN STREET CLASS BASED ON FUNCTIONAL AND DESIGN CATEGORIES

Design Category	Functional Category	
	Principal Arterial	Minor Arterial
High-Speed	I	N/A
Suburban	II	II
Intermediate	II	III or IV
Urban	III or IV	IV

EXHIBIT 10-4. FUNCTIONAL AND DESIGN CATEGORIES

Criterion	Functional Category			
	Principal Arterial	Minor Arterial		
Mobility function	Very important	Important		
Access function	Very minor	Substantial		
Points connected	Freeways, important activity centers, major traffic generators	Principal arterials		
Predominant trips served	Relatively long trips between major points and through-trips entering, leaving, and passing through the city	Trips of moderate length within relatively small geographical areas		
Design Category				
Criterion	High-Speed	Suburban	Intermediate	Urban
Driveway/access density	Very low density	Low density	Moderate density	High density
Arterial type	Multilane divided; undivided or two-lane with shoulders	Multilane divided; undivided or two-lane with shoulders	Multilane divided or undivided; one-way, two-lane	Undivided one-way, two-way, two or more lanes
Parking	No	No	Some	Significant
Separate left-turn lanes	Yes	Yes	Usually	Some
Signals/mi	0.5–2	1–5	4–10	6–12
Speed limit	45–55 mi/h	40–45 mi/h	30–40 mi/h	25–35 mi/h
Pedestrian activity	Very little	Little	Some	Usually
Roadside development	Low density	Low to medium density	Medium to moderate density	High density

Table 35. Level of service thresholds.

EXHIBIT 15-2. URBAN STREET LOS BY CLASS

Urban Street Class	I	II	III	IV
Range of free-flow speeds (FFS)	55 to 45 mi/h	45 to 35 mi/h	35 to 30 mi/h	35 to 25 mi/h
Typical FFS	50 mi/h	40 mi/h	35 mi/h	30 mi/h
LOS	Average Travel Speed (mi/h)			
A	> 42	> 35	> 30	> 25
B	> 34–42	> 28–35	> 24–30	> 19–25
C	> 27–34	> 22–28	> 18–24	> 13–19
D	> 21–27	> 17–22	> 14–18	> 9–13
E	> 16–21	> 13–17	> 10–14	> 7–9
F	≤ 16	≤ 13	≤ 10	≤ 7

Chapter 21 of the HCM describes a model for computing the free-flow speed for multilane highways. This model is based on the following equation:

$$S_f = S_b - f_{LW} - f_{LC} - f_M - f_A$$

Where

S_f = free-flow speed, mph;

S_b = base free-flow speed (may use 47, 52, 55, or 60 for speed limits of 40, 45, 50, or 55, respectively), mph;

f_{LW} = adjustment for lane width, mph;

f_{LC} = adjustment for lateral clearance, mph;

f_M = adjustment for median treatment, mph; and

f_A = adjustment for access points, mph.

The adjustment factors used in this equation indicate that lane width, lateral clearance, median type, and access point density can reduce the free-flow speed. The magnitude of the adjustments is listed in Table 36. Notably absent is an adjustment for heavy vehicles. This effect is accommodated as an adjustment to the analysis flow rate.

Summary of Relevance Research

This section examines the relationship between free-flow speed and two other variables: speed limit and segment length. It includes the guidance provided in the HCM (as described in the previous section) as well as the guidance provided in three other sources. One source that presents the relationship between free-flow speed and speed limit is Dowling et al. This research examined speed data from 10 speed measurement stations on four rural highways in three states. The following relationship was developed between free-flow speed and speed limit:

$$S_f = 14 + S_{pl}$$

Where

S_f = free-flow speed, mph; and

S_{pl} = posted speed limit, mph.

A second source is the Florida Department of Transportation. The FDOT *Quality/Level of Service Handbook* indicates that the free-flow speed can be estimated as being 5 mph faster than the posted speed limit.

Table 36. Free-flow speed adjustment factors for multilane highways.

Adjustment for Lateral Clearance			
Four-Lane Highways		Six-Lane Highways	
Lateral Clearance, ft	f_{LC} , mph	Lateral Clearance, ft	f_{LC} , mph
12	0.0	12	0.0
10	0.4	10	0.4
8	0.9	8	0.9
6	1.3	6	1.3
4	1.8	4	1.7
2	3.6	2	2.8
0	5.4	0	3.9
Adjustment for Lane Width		Adjustment for Access Point Density (right side only)	
Lane Width, ft	f_{LW} , mph	Access Density, ap/mi	f_A , mph
12	0.0	0	0.0
11	1.9	10	2.5
10	6.6	20	5.0
Adjustment for Median Treatment		30	7.5
Median Type	f_M , mph	≥ 40	10.0
Undivided	1.6		
Divided	0.0		

The guidance from Dowling et al., FDOT, and the HCM is summarized in Figure 19. The guidance provided in Chapter 10 of the HCM suggests that the free-flow speed is slightly slower than the speed limit. In contrast, FDOT, Chapter 21 of the HCM, and Dowling et al. suggest that the free-flow speed is 5 to 7 mph faster than the speed limit. However, it must be remembered that the latter two sources are based on rural highway data.

A third source of insight into the relationship between free-flow speed and speed limit is the data collected by Fitzpatrick et al. This database includes measurements of free-flow speed on 35 urban

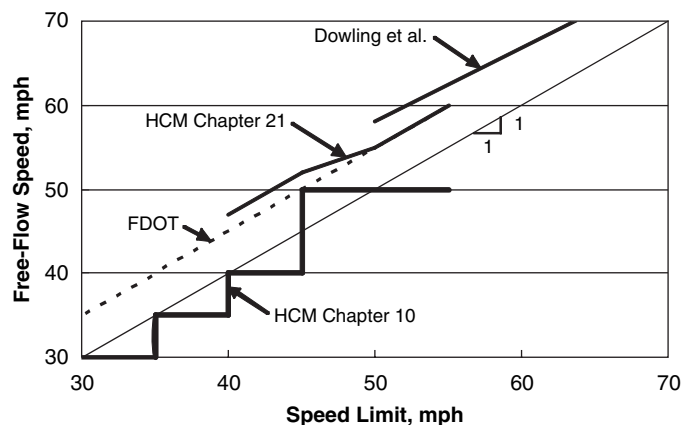

Figure 19. Comparison of guidance relating free-flow speed to speed limit.

or suburban arterial street segments in six states. The database collectively has segments ranging in length from 0.4 to 1.0 mi; access point densities ranging from 0 to 103 per mi; speed limits ranging from 30 to 55 mph; lane widths ranging from 9.5 to 14.0 ft, and median types that included no median, non-restrictive, and restrictive.

The relationship between speed limit and free-flow speed on urban streets, as represented by this equation is shown in Figure 20. The data points shown in the figure represent the data collected by Fitzpatrick et al. The coefficient of determination (R^2) for the model is 0.66, which implies that the model explains 66% of the variability in the data.

The trends shown in Figure 20 indicate that free-flow speed is typically faster than the speed limit. However, the relationship between the two speeds is not consistent with the guidance described previously. This difference is partly due to the fact that speed limit is correlated with access point density—higher speed limits are associated with lower densities. The trend in Figure 20 also suggests that the free-flow speed and the speed limit tend to equal one another at a certain specific speed limit. Specifically, the trend suggests that the free-flow speed tends to equal the speed limit of about 45 mph on urban arterial streets. The trend suggests that drivers are content with this speed limit when traveling on an arterial street. However, drivers will likely adopt a free-flow speed that is in excess of the speed limit if that limit is posted at a lower value.

Exhibit 15-3 of HCM Chapter 15 provides a table of running time rates for urban street applications. The trend in these rates suggests that speed is influenced by segment length. This effect of length is inferred to affect all vehicles traveling along the segment. The implication of this inference is that free-flow speed is influenced by segment length.

The rates listed in Exhibit 15-3 of the HCM are shown in Figure 21, after conversion to an equivalent speed value. The trend lines converge to the stated free-flow speed at the right side of the figure. Given that they converge to the free-flow speed and that length affects all vehicles, it is rationalized that the designated “free-flow speed” to which the rates converge on long segments is actually an “ideal free-flow speed.” In this context, the “ideal free-flow speed” is defined to be the free-flow speed on long street segments such that the potential need to stop at the next signal does not have to be factored into the driver’s speed choice. Thus, *ideal* free-flow speed can only be field-measured on long street segments. It is an abstract concept for short segments and can only be estimated through the use of a mathematical relationship. For example, if the field-measured free-flow speed on a Class 1 street with a length of 0.4 mi is 44 mph, then the trend lines in Figure 21 indi-

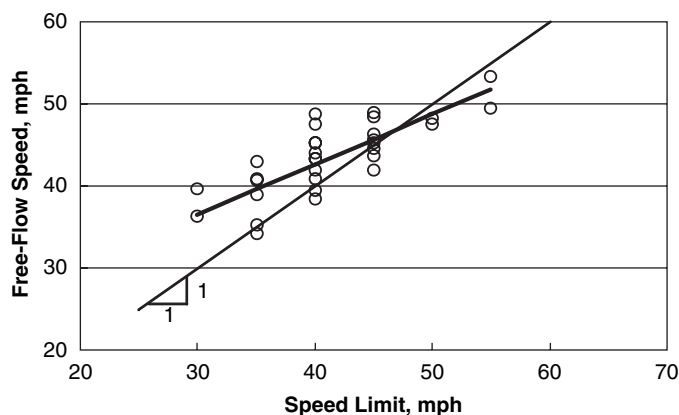

Figure 20. Relationship between speed limit and free-flow speed.

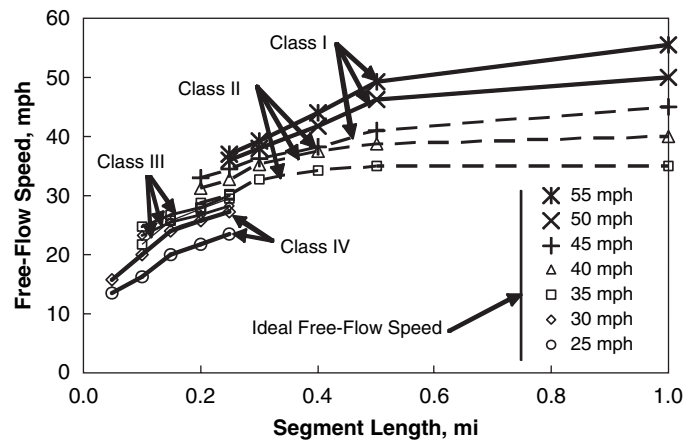

Figure 21. Influence of segment length on free-flow speed.

cate that the ideal free-flow speed for this street is 55 mph. Yet, it is unlikely that a 55-mph free-flow speed would ever be field-measured at this location because of its short length.

The level of service thresholds in Chapter 15 of the HCM are not changed by this refinement in terminology, just the wording that describes their basis. To accommodate this change, the HCM would be changed to state that urban street level of service is based on *ideal* free-flow speed (as defined above), rather than free-flow speed.

The effect of segment length on free-flow speed is possibly explained as a tendency of drivers to moderate their speed based on their ability to comfortably accelerate from, and decelerate to, a stop condition at the intersections bounding the segment. In other words, for a given segment length, there is a speed to which a driver will accelerate, maintain for a minimum length of time during which he/she will assess the possible need to stop at the downstream signal, and then decelerate to this stop. For short segments, this speed is likely to be slower than the ideal free-flow speed that drivers would otherwise choose (based on their consideration of speed limit, access point density, and other factors). Out of caution, drivers may adopt this speed even if the signals are coordinated and they are traveling in a progressed platoon.

Procedure for Estimating Free-Flow Speed

This section describes a procedure for estimating the ideal free-flow speed for an urban street. These estimates can be used as default values when field data are not available. The procedure is based on an equation that was developed by Bonneson et al. and calibrated using data collected by Bonneson et al. and by Fitzpatrick et al. The combined database includes measurements of free-flow speed for 50 urban street segments, 6 of which are classified as collector streets and the balance of which are classified as arterial streets. The combined database collectively includes sites with curb and gutter as well as sites with shoulder treatments. The number of through lanes ranged from 2 to 6 (1 to 3 in each direction). The number of segments with no median, non-restrictive median, and restrictive median were in nearly equal distribution. The access point density ranged from 0.0 to 103 access points/mi.

Free-flow speed is defined to be the average speed at which through automobile drivers travel under low-volume conditions along an urban street when all the signals are green as they travel along the street. The “base” free-flow speed is defined to be the free-flow speed on long street segments such that the potential need to stop at the next signal does not have to be factored into the drivers’ speed choice.

Base free-flow speed can be estimated using the following relationship:

$$S_{f_0} = S_o + f_{CS} + f_A$$

Where

- S_{f_0} = base free-flow speed, mph;
- S_o = speed constant, mph;
- f_{CS} = adjustment for cross section, mph; and
- f_A = adjustment for access points, mph.

The speed constant and adjustment factors are listed in Table 37. Base conditions are represented by a non-restrictive median (or no median) with no access points and 4 ft or more of surfaced pavement beyond the outside edge of traveled way. When the conditions present are different than these base conditions, then one or more adjustment factors should be obtained from Table 37 to adjust the speed constant.

The base free-flow speed is defined to be the free-flow speed on long street segments such that the potential need to stop at the next signal does not have to be factored into the driver’s speed choice. This speed can only be field-measured on long street segments. It is an abstract concept for short segments and can only be estimated through the use of a mathematical relationship. Because of its abstract nature, a base free-flow speed estimate from the equation provided above may seem to be relatively large for a street with a lower speed limit. In reality, most streets having a lower speed limit are also likely to be short such that speed choice is moderated by signal spacing. Under these circumstances, the analyst’s expectation regarding the base free-flow speed may

Table 37. Ideal free-flow speed adjustment factors for urban streets.

Speed Limit, mph	Speed Constant (S_o), mph	Median Type	Percent w/ Restricted Median, %	Adjustment for Cross Section (f_{CS}), mph	
				No Curb	Curb and Gutter
25	37.4	Restrictive	20	0.3	-0.9
30	39.7		40	0.6	-1.4
35	42.1		60	0.9	-1.8
40	44.4		80	1.2	-2.2
45	46.8		100	1.5	-2.7
50	49.1	Non-Restrictive	Not applicable	0.0	-0.5
55	51.5	No median	Not applicable	0.0	-0.5
Access Density, access points/mi	Adjustment for Access Points (f_A), mph ¹				
	1 Lane	2 Lanes	3 Lanes	4 Lanes	
0	0.0	0.0	0.0	0.0	
2	-0.2	-0.1	-0.1	0.0	
4	-0.3	-0.2	-0.1	-0.1	
10	-0.8	-0.4	-0.3	-0.2	
20	-1.6	-0.8	-0.5	-0.4	
40	-3.1	-1.6	-1.0	-0.8	
60	-4.7	-2.3	-1.6	-1.2	

¹Number of lanes corresponds to number of through lanes on the subject segment in the direction of travel.

be skewed because what has actually been observed at this location is free-flow speed (not the base free-flow speed), as influenced by segment length.

Default Value Guidance

HCM 2000 has one simple table of default values for free-flow speed (HCM 2000 Exhibit 10-5). For each of the four classes of urban streets there is a recommended default value for free-flow speed. These default values are also what define the level of service thresholds shown in HCM 2000 Exhibit 15-2.

The methodology presented in this Guidebook requires more than a simple replacement of Exhibit 10-5. Rather than develop default free-flow speed estimates, use of the equation on the preceding page should be considered.

Saturation Flow Rates and Lane Utilization Factors for Dual and Triple Left-Turn Lanes

This section focuses on HCM procedures for determining the saturation flow rate and lane utilization factors for use in the analysis of signalized intersection operations for signalized intersections with dual and triple left-turn lanes. Recommended values provided in other research studies are summarized.

The current default value for a saturation flow rate for a single left-turn lane is 1,805. This saturation flow rate default value is derived by multiplying the base saturation flow rate of 1,900 by 95%, as shown in Equation 16-7 in the HCM. No saturation flow rate default value is given in the HCM for dual or triple left-turn lanes. The current default value for the lane utilization adjustment factor for dual left-turn lanes is 0.971, as found in Exhibit 10-23 in the HCM. No lane utilization default value exists for triple left-turn lanes. The HCM provides an option for 0.971 to be used as a default value for triple left-turn lanes; however, a survey of local conditions is preferred.

HCM 2000 Procedures

The HCM provides methodologies for determining the saturation flow rate and lane utilization factors for dual and triple left-turn lanes for signalized intersections. A summary of the equations which consider these values is provided below. Chapter 16 outlines the methodology for analyzing signalized intersections. This methodology includes the determination of the saturation flow rate. The equation for this calculation is shown below:

$$s = s_o N f_w f_{HV} f_g f_p f_{bb} f_a f_{LU} f_{LT} f_{RT} f_{Lpb} f_{Rpb}$$

Where

- s = saturation flow rate for subject lane group, expressed as a total for all lanes in lane group (veh/h);
- s_o = base saturation flow rate per lane (pc/hr/ln);
- N = number of lanes in lane group;
- f_w = adjustment factor for lane width;
- f_{HV} = adjustment factor for heavy vehicles in traffic stream;
- f_g = adjustment factor for approach grade;
- f_p = adjustment factor for existence of a parking lane and parking activity adjacent to lane group;
- f_{bb} = adjustment factor for blocking effect of local buses that stop within intersection area;

74 Default Values for Highway Capacity and Level of Service Analyses

f_a = adjustment factor for area type;
 f_{LU} = adjustment factor for lane utilization;
 f_{LT} = adjustment factor for left turns in lane group;
 f_{RT} = adjustment factor for right turns in lane group;
 f_{Lpb} = pedestrian adjustment factor for left-turn movements; and
 f_{Rpb} = pedestrian-bicycle adjustment factor for right-turn movements.

As shown in the above equation, the adjustment factor for left turns in a lane group and the adjustment factor for lane utilization are two of the eleven adjustment factors used in calculating the saturation flow rate for the subject lane group.

The adjustment factor for left turns in lane group is calculated using the following equations (found in Exhibit 16-7):

Exclusive Lane: $f_{LT} = 0.95$

Shared Lane: $f_{LT} = \frac{1}{1.0 + 0.05 P_{LT}}$

Where

P_{LT} = proportion of left turns in lane group

The equation for determining the adjustment for lane utilization is found in Exhibit 16-5:

$$f_{LU} = \frac{v_g}{(v_{g1}N)}$$

Where

f_{LU} = lane utilization adjustment factor,

v_g = unadjusted demand flow rate for lane group (veh/hr),

v_{g1} = unadjusted demand flow rate on single lane with highest volume in lane group (veh/hr),
and

N = number of lanes in lane group.

Summary of Relevant Research

Six research studies were reviewed with respect to procedures for determining the saturation flow rate and lane utilization factors for analysis of intersections with multiple left-turn lanes. A summary of these research studies is provided below.

Spring, G. S., and Thomas, A. Double Left-Turn Lanes in Medium-Size Cities. *Journal of Transportation Engineering*, Vol. 125, March/April 1999, pp. 138–143.

Double left-turn data from 30 intersections in the city of Greensboro, North Carolina, were analyzed with respect to relationships among performance and geometric characteristics. Results indicated that the overall saturation flow left-turn adjustment value of 0.92, recommended by the 1985 HCM, appears reasonable for the inside (curb) lane. Values of 0.86 to 0.88 are more appropriate for the outside (farthest from median) lane adjustments. A single left-turn factor of 0.92 is recommended for dual left-turn approaches where the turn angle is very close to 90° and where the intersection functions as a T-intersection (i.e., no opposing flow), or where the turn angle for a four-leg intersection is less than 90°. Separate left-turn factors for each of the two left-turn lanes are recommended at all other dual left-turn lane approaches. Lane utilization factors were not discussed.

Zegeer, J. D. Field Validation of Intersection Capacity Factors. *Transportation Research Record No. 1091*, 1986, pp. 67–77.

The purpose of this study was to verify the saturation flow rates and traffic volume adjustment factors used in various capacity analysis procedures by assembling a relatively extensive database. Saturation flow headways were collected for more than 20,000 headways around the United States. Results indicated that left-turning vehicles in saturation flow at single left-turn lanes experienced an average of 3% reduction in saturation flow rate when compared with through-lane headways at comparable locations. Therefore, a 0.97 adjustment factor for single left-turn lanes is recommended. For dual left-turn lanes, results indicated that 50.3% of the vehicles surveyed were in the inside (curb) lane. The lane distribution suggests a lane utilization factor of 0.97 for the dual left-turn lane, when compared with single exclusive left-turn lanes. Combining the single and dual turn lane adjustment factors for protected turn phase operations yields an overall factor that can be applied to unadjusted turn volumes in dual exclusive turn lanes. The overall adjustment factor of 0.94 for a dual left-turn lane was recommended.

Kagolanu, K., and Szplett, D. Saturation Flow Rates of Dual Left-Turn Lanes. *Proc., Second International Symposium on Highway Capacity*, Akcelik, R. (ed.), Volume 1, 1994, pp. 325–344.

This paper studied the saturation flow headways in the inside and outside dual left-turn lanes, distribution in lanes, and effects of striping and geometry. A total of 2,359 headways were collected and subjected to statistical analyses from sites in Boise, Idaho. Results indicated that left-turn lane use is 46% for the inside (curb) lane and 54% for the outside lane. Using the lane utilization factor value equation presented earlier, a lane utilization factor value of 0.89 is calculated. The average saturation flow rate calculated using the mean of the headways was 1,640 for the inside (curb) lane and 1,691 for the outside lane. Because the observed saturation flow rate was not corrected for other adjustment factors, it is inappropriate to compute a left-turn adjustment factor. The study also suggested that the striping and receiving lanes may factor into the observed saturation flow rates.

Stokes, R. W., Messer, C. J., and Stover, V. G. Saturation Flows of Exclusive Double Left-Turn Lanes. *Transportation Research Record No. 1091*, 1986, pp. 86–95.

This paper developed estimates of the saturation flows at exclusive double left-turn lanes. The results are based on observations of 3,458 completed left turns from exclusive double left-turn lanes on 14 intersections in Austin, College Station, and Houston, Texas. Results indicated that the average double left-turn saturation flow rate varied by city. An average saturation flow rate for double left-turn lanes of 1,636, 1,636, and 1,800 was found in Austin, College Station, and Houston, respectively. The study also concluded that any differences in the departure headways used to calculate saturation flow for vehicles in the inside (curb) lane, and outside lane are not large enough to be detected with the given sample sizes. The paper made no recommendations for a left-turn adjustment factor or lane utilization factor due to the inconsistency of the results.

Leonard II, J. D. Operational Characteristics of Triple Left Turns. *Transportation Research Record No. 1457*, 1994, pp. 104–110.

This paper studied the characteristics of triple left turns using five triple left-turn sites in Orange County, California. A sample consisting of 4,742 lane cycles was compiled for analysis. Results indicate that the average saturation flow rate observed was 1,930. A left-turn adjustment factor was not recommended due to the limited number of survey locations. Lane utilization factors of 1.01 for the inside (curb)/middle lane group and 0.98 for the outer lane group were computed.

Sando, T., and Mussa, R. N. Site Characteristics Affecting Operation of Triple Left-Turn Lanes. *Transportation Research Record No. 1457*, 1994, pp. 104–110.

This study analyzed the influence of a number of geometric factors found at 15 triple left-turn lane sites in Florida on saturation flow rate and lane utilization. A total of 2,395 lane cycles were

Table 38. Summary of left-turn factors by source.

Source	Dual Left-Turn Lanes		Triple Left-Turn Lanes	
	f_{LT}	f_{LU}	f_{LT}	f_{LU}
Highway Capacity Manual	--	0.971	--	0.971
Double Left-Turn Lanes in Medium-Size Cities, Spring	0.92 Inside (curb)	0.86- 0.88 Outside	--	--
Field Validation of Intersection Capacity Factors, Zegeer	0.97	0.97	--	--
Saturation Flow Rates of Dual Left-Turn Lanes, Kagolanu	--	0.89	--	--
Operational Characteristics of Triple Left Turns, Leonard	--	--	--	1.01 Inside (curb)/ Middle
Site Characteristics Affecting Operation of Triple Left-Turn Lanes, Sando	--	--	--	0.98 Outside
Site Characteristics Affecting Operation of Triple Left-Turn Lanes, Sando	--	--	--	0.88

observed. Results indicated that the average saturation flow rate observed was 1,859. Left-turn factors of 0.91 and 0.92 were calculated for two intersections; however, due to the small sample size, these values were not analyzed for statistical significance. An overall average lane utilization factor of 0.88 was calculated. A review of the data showed that lane usage is dependent on the intersection geometric configuration.

Default Value Guidance

This section of the Guidebook focused on HCM procedures for determining the saturation flow rate and lane utilization factors for use in the analysis of intersection operations for locations with multiple left-turn lanes. Research studies have recommended varying left-turn adjustment factors and lane utilization factors for use with dual and triple left-turn lanes as summarized in Table 38.

It can be concluded that there are no universally accepted values for left-turn lane adjustment factors or lane utilization factors. Although local data will provide the truest measure of the appropriate adjustment factors at a location, these data are typically not collected due to project budget and time constraints. When local data are not available, the following default values may be considered:

Left-Turn Lane Saturation Flow Adjustment Factor (Dual Left-Turn Lanes)

- Set the default value to 0.97.

Left-Turn Lane Utilization Factor (Dual Left-Turn Lanes)

- Maintain the current default value of 0.971 as suggested by the HCM.

Left-Turn Lane Saturation Flow Adjustment Factor (Triple Left-Turn Lanes)

- Set the default value to 0.97 until research can be completed.

Left-Turn Lane Utilization Factor (Triple Left-Turn Lanes)

- Set the default value to 0.971 as suggested by the HCM until further research is available.

Caution: Lane utilization values can be significantly influenced by the presence of freeway ramps located downstream of the intersection.

Guidance for Preparing Service Volume Tables

A service volume table can provide an analyst with an estimate of the maximum number of vehicles a facility can carry at a given Level of Service. The use of a service volume table is most appropriate in certain planning applications where it is not feasible to evaluate every segment or node within a study area. Examples of this would be city, county, or statewide planning studies where the size of the study area makes it infeasible to conduct a capacity or level of service analysis for every roadway segment. For these types of planning applications, the focus of the effort is to simply highlight “potential” problem areas (e.g., locations where demand may exceed capacity or where a desired level of service threshold may be exceeded). For such applications, developing a service volume table can be a useful sketch planning tool, provided the analyst understands the limitations of this method.

To develop a service volume table, the analyst needs to develop a default value for each of the input parameters. As discussed in previous chapters of this Guidebook, several of the default values have a very significant impact on the resulting level of service. For this reason, great care should be used when developing a set of default values that the analyst believes is most appropriate for the local condition. Further, when applying the service volume table, it is important to recognize that the various roadway segments being evaluated are not likely to have the exact values for all the input parameters. Accordingly, conclusions drawn from the application of service volume tables should be considered and presented as “rough approximations.”

Sample Service Volume Tables

For the purposes of this Guidebook, an example of how to construct a service volume table was prepared for a basic freeway segment and for an urban street facility. These two facility types were selected since they would likely be common applications of service volume tables within an urban area. *The tables presented below were developed for illustrative purposes only.* The analyst should carefully select default values that are most appropriate for the local condition.

Basic Freeway Segment Example

For the basic freeway segment example, Table 39 was prepared based on the following assumed default values:

- Base free-flow speed: 70 mph
- Lane width: 12 ft
- Shoulder width: 6 ft
- Terrain: level
- %HV: 5

78 Default Values for Highway Capacity and Level of Service Analyses

- Driver population factor: 1.0
- PHF: 0.92
- Interchange density: 1 interchange per mile.

Table 39 could be used to estimate the number of through lanes required to obtain a desired level of service for basic freeway segments under the above default conditions. The information in the table provides the analyst with the estimated maximum volume the facility can carry (in each direction) for a given level of service. Another application of the table would be to quickly identify freeway segments that may be operating beyond a given level of service threshold.

Urban Street Facility Example

For the urban street example, Table 40 was prepared based on the following assumed default values:

- Urban street class: II
- Signal density (signals/mile): 3
- Free-flow speed: 40 mph
- Cycle length: 90 s
- Effective green ratio: 0.45
- Adjusted saturation flow rate: 1,800 pcphpl
- Arrival type: 4
- Unit extension: 3
- Initial queue: 0
- Other delay: 0
- PHF: 0.92
- % lefts, % rights: 10
- Left-turn bay present: Yes
- Lane utilization factor: (varies, consult Exhibit 10-23)

Table 40 could be used to estimate how many vehicles per hour an urban street could carry per direction at a given level of service, or again, to quickly identify potential problem areas within a large study area. For this example, a few important points are worth noting. First, compared with

Table 39. Example service volumes for basic freeway segments.

Number of Lanes	FFS (mph)	Service Volumes (veh/hr) for LOS				
		A	B	C	D	E
2	63	1230	2030	2930	3840	4560
3	65	1900	3110	4500	5850	6930
4	66	2590	4250	6130	7930	9360
5	68	3320	5430	7820	10,070	11,850

LOS: Level of service
FFS: Free-flow speed

Table 40. Example service volumes for Class II urban street.

Lanes	Service Volumes (veh/hr)				
	A	B	C	D	E
1	N/A	N/A	670	840	880
2	N/A	N/A	1470	1690	1770
3	N/A	N/A	2280	2540	2660
4	N/A	N/A	3090	3390	3550

N/A: not achievable given assumed default values

the basic freeway example, many more default values are required to develop the service volume table. Second, because of the many factors that influence the operation of an urban street, it is highly unlikely (much more so than for a basic freeway segment) that any urban street facility would experience uniform characteristics over its entire length. For this reason, it is important to remember that conclusions drawn from applying a service volume table should be considered “rough approximations.”

Sensitivity Analysis

This chapter has illustrated two points: (1) the importance of selecting appropriate default values when constructing service volume tables (or conducting any planning or operational analysis that relies on default values) and (2) that some facilities are much more sensitive to default values than others. To illustrate these two points, the same freeway and urban street examples discussed in the previous section were tested against a range of default values to determine the impact of modifying the default values on the resulting service volume.

Basic Freeway Segment Example

For the basic freeway segment example, the first seven default values shown below were held constant, and the last three were individually varied over the range indicated in the bulleted list. For each example, the change in the maximum service volume at level of service “D” was evaluated over the range indicated for percent grade, PHF, and interchange density.

- Base free-flow speed: 70 mph
- Lane width: 12 ft
- Terrain: level (for base conditions)
- %HV: 5
- Driver population adjustment: none
- Number of lanes per direction (3)
- Shoulder width: 6 ft
- Percent grade: *varied from 2 to 6%*
- PHF: *varied from 0.85 to 0.95*
- Interchange density: *varied from 0.5 to 2 interchanges per mile.*

Figure 22 below illustrates the change in the level of service “D” maximum service volume by varying a 1.0 mi sustained grade from 2 to 6%. As shown in the figure, percent grade can signifi-

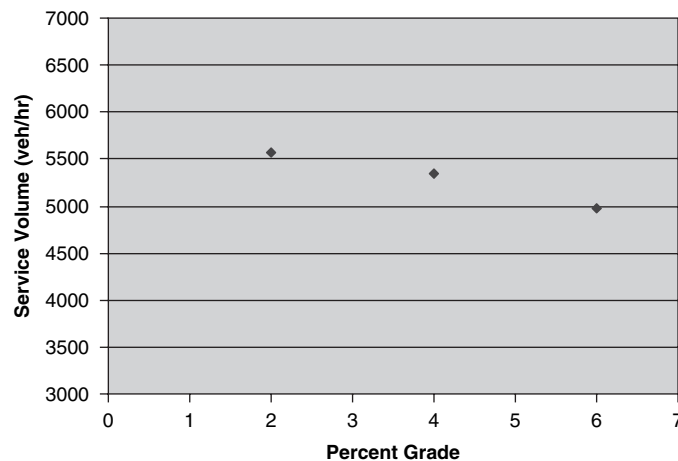

Figure 22. Service volume versus percent grade.

80 Default Values for Highway Capacity and Level of Service Analyses

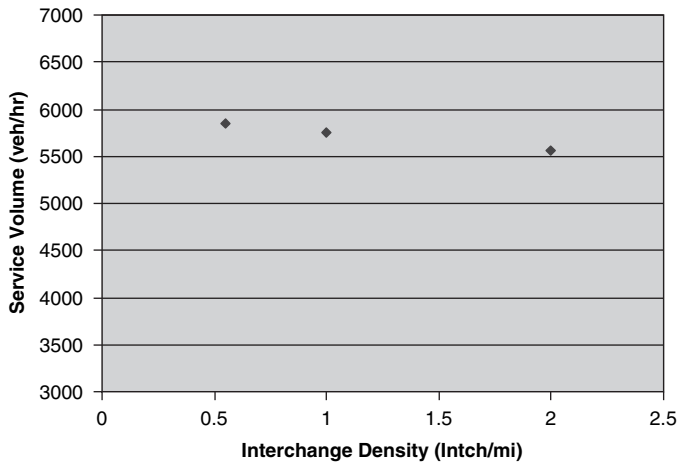

Figure 23. Service volume versus interchange density.

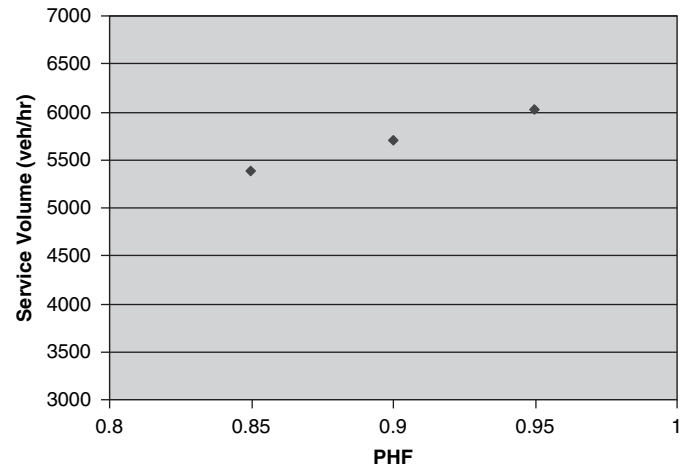

Figure 24. Service volume versus PHF.

cantly affect the resulting service volume. Recall from previous sections of this guide that percent grade is one of the more highly sensitive default values for basic freeway sections. Accordingly, it is very important to carefully select the most appropriate value for the segment being studied.

Figure 23 illustrates the impact of varying the interchange density from 0.5 to 2.0 interchanges per mile. A significant change in the interchange density has a relatively modest impact on the service volume (an approximate 5% change over the range studied).

Figure 24 illustrates the impact of varying the PHF from 0.85 to 0.95. The change in PHF resulted in a much more significant impact over the range. (Recall from previous sections of this guide that PHF is one of the more highly sensitive default values, which is why it is important to carefully select the most appropriate PHF value for the facility being studied.)

Urban Street Facility Example

For the urban street example, the first 11 default values shown below were held constant and the last three default values were individually varied over the range indicated in the bulleted list. For each example the change in the maximum service volume at level of service “D” was evaluated over the range indicated for effective green ratio, signal density, and PHF.

- Urban street class: II
- Free-flow speed: 40 mph
- Cycle length: 90 s
- Adjusted saturation flow rate: 1,800 pcphpl
- Arrival type: 4
- Unit extension: 3 s
- Initial queue: 0
- Other delay: 0
- % lefts, % rights: 10
- Left-turn bay present: Yes
- Lane utilization factor: (consult Exhibit 10-23)
- Effective green ratio: *varied from 0.4 to 0.5*
- Signal density (signals/mile): *varied from 1 to 5 signals per mile*
- PHF: *varied from 0.85 to 0.95*

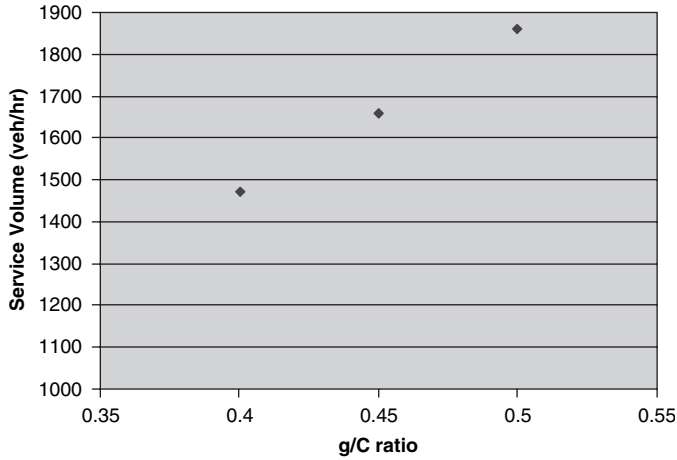

Figure 25. Service volume versus g/C ratio.

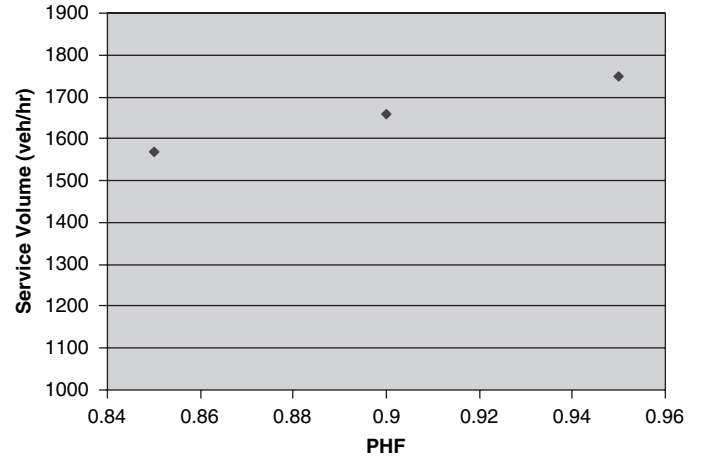

Figure 26. Service volume versus PHF.

Figure 25 illustrates the change in the level of service “D” maximum service volume by varying the green ratio from 0.4 to 0.5. The change in g/C ratio over the range from 0.4 to 0.5 had a very significant impact on the maximum service volume (approximately 25% over the range). For this reason, great care should be taken when selecting a representative g/C ratio for the entire facility.

Figure 26 illustrates the impact of varying the PHF from 0.85 to 0.95. The change in PHF resulted in a significant impact over the range. It is important to carefully select the most appropriate value for the condition facility being studied.

Figure 27 illustrates the change in the level of service “D” maximum service volume that occurs when the signal density varies from 1 to 5 signals per mile. The change in signal density had a very significant impact on the maximum service volume (approximately 25% over the range).

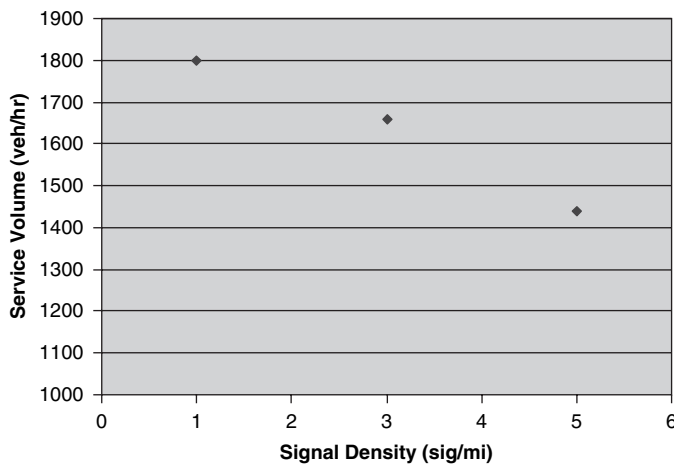

Figure 27. Service volume versus signal density.

Sensitivity Analysis

A sensitivity analysis was conducted for all input parameters where HCM 2000 suggests default values. The intent of this analysis was to determine which input parameters deserved further study based on the relative change in the relevant service measure due to the change in the value of the input parameter. Those input parameters that had a high degree of impact on the relevant service measures were recommended for further study. Input parameters considered for the sensitivity analysis were those that the HCM 2000 has suggested default values for. Specifically, default values are suggested for 63 input parameters described in eight chapters of Part II of HCM 2000: Urban Streets, Signalized Intersections, Pedestrians, Bicycles, Multilane Highways, Two-Lane Highways, Basic Freeway Segments, and Ramps and Ramp Junctions.

To facilitate the ranking of the input parameters, the following three thresholds were established.

- If varying the input parameter within its reasonable range results in 0 to 10% change in the service measure, the parameter is considered to have a low degree of sensitivity.
- If varying the input parameter within its reasonable range results in 10 to 20% change in the service measure, the parameter is considered to have a moderate degree of sensitivity.
- If varying the input parameter within its reasonable range results in more than 20% change in the service measure, the parameter is considered to have a high degree of sensitivity.

In general, input parameters that demonstrated a moderate to high degree of sensitivity were considered for further investigation. The HiCAP software was used to determine how the variation in input parameter values influenced the level of service for each of these methodologies.

Urban Streets

In the Urban Streets methodology, HCM 2000 provides default values for two input parameters: free-flow speed and signal density. (See Table A-1.) In each of four street classifications, a default value is provided. Thus, a separate set of sensitivity analyses was developed corresponding to each of the four street classifications. The effects of free-flow speed and signal density on the service measure (and the level-of-service) were evaluated under low, average, and high traffic volume conditions. Each sensitivity analysis began with the establishment of a base scenario, and input values for the target parameter were varied to record its effects.

A summary of the base scenario is described in the following section.

Base Scenario

A set of base parameters was selected for determining the sensitivity of each of the two input parameters listed above. These parameters represent the typical characteristics of an urban street

Table A-1. Summary of input parameters for urban streets.

Input Variable	Default Value	Methodology	HCM Source
Free-flow speed (mph)	50/40/35/30	Urban Streets	Exhibit 10-5
Signal density (signals/mi)	0.8/3/6/10	Urban Streets	Exhibit 10-6

and could be present in any of the four urban street classes. However, it is possible that a different set of characteristics can produce different sensitivity results.

- Cycle length at signalized intersections, $s = 100.0$ (default value for a signal in a non-CBD area)
- g/C ratio at signalized intersections = 0.30
- Lane group capacity, veh/hr = 1,500
- Arrival type = 3 (default value for arrival type at an uncoordinated signal)
- Unit extension, $s = 0.0$ (assumed pre-timed signals)
- Initial queue, veh = 0
- Initial delay, $s = 0.0$
- Other delay, $s = 0.0$
- Analysis period, $h = 0.25$
- Low congestion— v/c ratio at signalized intersections = 0.30
- Average congestion— v/c ratio at signalized intersections = 0.60
- High congestion— v/c ratio at signalized intersections = 0.90

Default parameters evaluated in this methodology: free-flow speed and signal density in each street class.

Service measure is average travel speed and computed according to the following equation:

$$S_A = \frac{3600 \sum(L)}{\sum(T_R + d + d_m)} \quad (\text{HCM Eq. 15-6b})$$

Where

S_A = average travel speed of through vehicles in the segment (mph);

L = segment length (mi);

T_R = running time on the segment (= $t_R L$) (s);

t_R = running time per mile along the segment, from Exhibit 15-3 (s/mi);

d = control delay for through movements at the signalized intersection at the end of the segment (s); and

d_m = delay for through movements at locations other than the signalized intersection (e.g., mid-block delay) (s).

Findings and Recommendations

In the Urban Streets methodology, the analyst uses the free-flow speed to look up running time which directly affects the average travel speed calculation. For all four urban street classifications, free-flow speed has low sensitivity on the travel speed and level of services. (The results are shown on Tables A-2 through A-5.) Because of the low sensitivity of this input parameter, the use of free-flow speed default values, as suggested by the HCM, are adequate.

The signal density has a direct impact on intersection delays (i.e., as the signal density increases, the total signal delay increases). Within the ranges specified in the HCM, the signal density can alter the computed travel speed by as much as 60%. (See Tables A-6 through A-9.) The effect is less

Table A-2. Free-flow speed sensitivity—Class 1.

CLASS 1	Low Congestion			Avg. Congestion			High Congestion		
	v/c = 0.3			v/c = 0.6			v/c = 0.9		
Free-flow Speed, mph	45	50	55	45	50	55	45	50	55
% Default Change	-10%	0%	10%	-10%	0%	10%	-10%	0%	10%
Avg. Travel Speed	35.3	38.3	41.1	34.3	37.1	40	32.9	35.5	38.1
LOS	B	B	B	B	B	B	C	B	B
% Change in Results	-8%	0%	7%	-8%	0%	8%	-7%	0%	7%

Table A-3. Free-flow speed sensitivity—Class 2.

CLASS 2	Low Congestion			Avg. Congestion			High Congestion		
	v/c = 0.3			v/c = 0.6			v/c = 0.9		
Free-flow Speed, mph	35	40	45	35	40	45	35	40	45
% Default Change	-13%	0%	13%	-13%	0%	13%	-13%	0%	13%
Avg. Travel Speed	18.8	19.6	19.9	17.7	18.5	18.7	16.4	17	17.2
LOS	D	D	D	D	D	D	E	E	D
% Change in Results	-4%	0%	2%	-4%	0%	1%	-4%	0%	1%

Table A-4. Free-flow speed sensitivity—Class 3.

CLASS 3	Low Congestion			Avg. Congestion			High Congestion		
	v/c = 0.3			v/c = 0.6			v/c = 0.9		
Free-flow Speed, mph	30	35	40	30	35	40	30	35	40
% Default Change	-14%	0%	14%	-14%	0%	14%	-14%	0%	14%
Avg. Travel Speed	12	12.3	12.3	11.2	11.4	11.4	10.2	10.3	10.3
LOS	E	E	E	E	E	E	E	E	E
% Change in Results	-2%	0%	0%	-2%	0%	0%	-1%	0%	0%

Table A-5. Free-flow speed sensitivity—Class 4.

CLASS 4	Low Congestion			Avg. Congestion			High Congestion		
	v/c = 0.3			v/c = 0.6			v/c = 0.9		
Free-flow Speed, mph	25	30	35	25	30	35	25	30	35
% Default Change	-17%	0%	17%	-17%	0%	17%	-17%	0%	17%
Avg. Travel Speed	7.3	7.9	8.2	6.8	7.3	7.5	6.1	6.6	6.8
LOS	E	E	E	F	E	E	F	F	F
% Change in Results	-8%	0%	4%	-7%	0%	3%	-8%	0%	3%

dramatic when the signals are coordinated for progression. In general, the analyst should take care in the selection of signal density value and should compute intersection delays and signal density when practical. Caution is advised when using the methodology provided in Exhibit 10-4 of HCM 2000 because there are overlapping ranges of signal density between the urban classifications. Guidance in estimating signal density was provided earlier in this report.

Signalized Intersections

The signalized methodology is the most complex method in the HCM 2000. Because an intersection has more than one approach and because the capacity for each approach is governed by

Table A-6. Signal density sensitivity—Class 1.

CLASS 1	Low Congestion				Avg. Congestion				High Congestion			
	v/c = 0.3				v/c = 0.6				v/c = 0.9			
Signal Density, sig/mi	0.5	0.8	1	2	0.5	0.8	1	2	0.5	0.8	1	2
% Default Change	-38	0	25	150	-38	0	25	150	-38	0	25	150
Avg. Travel Speed	42.0	38.3	36.2	27.1	41.1	37.1	34.9	25.6	39.8	35.5	33.1	23.8
LOS	A	B	B	C	B	B	B	D	B	B	C	D
% Change in Results	10	0	-5	-29	11	0	-6	-31	12	0	-7	-33

Table A-7. Signal density sensitivity—Class 2.

CLASS 2	Low Congestion				Avg. Congestion				High Congestion			
	v/c = 0.3				v/c = 0.6				v/c = 0.9			
Signal Density, sig/mi	1	3	4	5	0.5	0.8	1	2	0.5	0.8	1	2
% Default Change	-67	0	33	67	-67	0	33	67	-67	0	33	67
Avg. Travel Speed	30.7	19.6	16.4	14.3	29.7	18.5	15.3	13.3	28.4	17.0	14.0	12.1
LOS	B	D	E	E	B	D	E	E	B	E	E	F
% Change in Results	57	0	-16	-27	61	0	-17	-28	67	0	-18	-29

Table A-8. Signal density sensitivity—Class 3.

CLASS 3	Low Congestion				Avg. Congestion				High Congestion			
	v/c = 0.3				v/c = 0.6				v/c = 0.9			
Signal Density, sig/mi	4	6	8	10	4	6	8	10	4	6	8	10
% Default Change	-33	0	33	67	-33	0	33	67	-33	0	33	67
Avg. Travel Speed	15.7	12.3	10.3	8.6	14.7	11.4	9.5	7.9	13.5	10.3	8.5	7.0
LOS	D	E	E	F	D	E	F	F	E	E	F	F
% Change in Results	28	0	-16	-30	29	0	-17	-31	31	0	-17	-32

Table A-9. Signal density sensitivity—Class 4.

CLASS 4	Low Congestion				Avg. Congestion				High Congestion			
	v/c = 0.3				v/c = 0.6				v/c = 0.9			
Signal Density, sig/mi	6	8	10	12	6	8	10	12	6	8	10	12
% Default Change	-40	-20	0	20	-40	-20	0	20	-40	-20	0	20
Avg. Travel Speed	11.7	9.7	7.9	6.6	10.9	8.9	7.3	6.1	9.9	8.1	6.6	5.5
LOS	D	D	E	F	D	E	E	F	D	E	F	F
% Change in Results	48	23	0	-16	49	22	0	-16	50	23	0	-17

geometry, traffic characteristics, and signal phasing, there are various ways to perform sensitivity analyses. To ensure consistent results, the sensitivity analyses were structured as follows.

- All approaches were given the same geometry, traffic characteristics, and signal phasing.
- The input parameters were varied in a similar manner for all approaches.
- When an input parameter was varied, splits were optimized within a preselected cycle length to ensure comparable delays for all movements (e.g., splits were adjusted to ensure that the left-turn movements did not suffer undue delays).
- The overall intersection delays were used in the comparative analysis.

Of the 19 parameters that the HCM provides default values for, the discussions on exclusive turn lanes were aimed more toward geometric design than operational analysis. In addition, average

queue spacing is not considered when assessing level of service for a signalized intersection. For this reason, these two input parameters were not included in the sensitivity investigation. Sensitivity levels for the other 17 input parameters were evaluated under low, average, and high traffic demand conditions (see Table A-10). Each sensitivity analysis began with a base scenario. Input values for the target parameter were then varied to record the impact on the service measure. A summary of the base scenario is described in the following section.

Base Scenario

The following values were adopted from much of the data set used to develop the service volume table on page 10-26 of the HCM.

Intersection Geometry

Four two-way approaches, two through lanes with an exclusive LT lane on each approach; 12-ft lane widths; right side curb parking with 8 maneuvers per hour.

- 0% grade
- Length of crosswalk, ft = 60
- Effective width of crosswalk, ft = 10
- Area type = CBD
- Pedestrian walking speed, ft/s = 4

Signal Operation

Cycle length, $s = 70.0$ for low demand, 80.0 for moderate demand, and 110.0 for high demand; four phases with protected lefts; lost time, $s/\text{phase} = 4$; start-up lost time, $s = 2$; yellow + all-red phase, $s = 4.0$; extension of green time, $s = 2.0$.

- Upstream filtering factor = 1.00
- Signalized control type = actuated
- Length of analysis period, $h = 0.25$
- Arrival type = 3 (default value for arrival type at an uncoordinated signal)
- Unit extension, $s = 3.0$

Table A-10. Signalized intersection input parameters.

Input Parameter	Default Value	Methodology	HCM Source
PHF	0.92	Signalized	Exh. 10-12
Length of analysis period (hr)	0.25	Signalized	Exh. 10-12
Cycle Length (sec)	70/100	Signalized	Exh. 10-16
Lost time (sec/cycle)	16/12/8	Signalized	Exh. 10-17
Arrival type (AT)	3,4	Signalized	Exh. 10-12
Unit extension time (sec)	3.0	Signalized	Exh. 10-12
Actuated control adjustment factor (k)	0.40	Signalized	Exh. 10-12
Upstream filtering adjustment factor (l)	1.00	Signalized	Exh. 10-12
Adjusted sat flow (veh/hr/ln)	1700/1800	Signalized	Exh. 10-19
Base sat flow (pc/hr/ln)	1900	Signalized	Exh. 10-12
Lane widths (ft)	12	Signalized	Exh. 10-12
Heavy vehicles	2%	Signalized	Exh. 10-12
Grades	0%	Signalized	Exh. 10-12
Parking Maneuvers	16/8/32	Signalized	Exh. 10-20
Local bus frequency (buses stopping/hr)	12/2	Signalized	Exh. 10-21
Pedestrians (peds/hr)	400/50	Signalized	Exh. 10-22
Lane utilization (f_{LU})	1.000/0.952/0.908/0.971/0.885	Signalized	Exh. 10-23

Traffic Demand

- Bus frequency, stops/h = 2
- Pedestrians, peds/h = 50
- Bicycles, bicycles/h = 0
- PHF = 0.92
- %HV = 2
- Base saturation flow rate, veh/hr = 1900
- Initial queue, veh = 0
- Low demand—volume = 250 (including 10% of RT and 10% of LT)
- Average demand—volume = 700 (including 10% of RT and 10% of LT)
- High demand—volume = 900 (including 10% of RT and 10% of LT)

The service measure is intersection delay. It is computed according to the following equation:

$$d = d_1(PF) + d_2 + d_3 \tag{HCM Eq. 16-9}$$

Where

- d = control delay per vehicle (s/veh);
- d₁ = uniform control delay assuming uniform arrivals (s/veh);
- PF = uniform delay progression adjustment factor, which accounts for effects of signal progression;
- d₂ = incremental delay to account for effect of random arrivals and oversaturation queues, adjusted for duration of analysis period and type of signal control; this delay component assumes that there is no initial queue for lane group at start of analysis period (s/veh); and
- d₃ = initial queue delay, which accounts for delay to all vehicles in analysis period due to initial queue at start of analysis period (s/veh)

Findings and Recommendations

PHF has a direct impact on the magnitude of the input demand. For example, applying a PHF of 0.90 to a demand volume of 1,000 increases the demand volume by over 11%. Varying the PHF from 0.60 to 1.00 results in a significant increase in delay, especially when the demand is high or near saturation (see Table A-11).

The length of the analysis period is used within the calculation of incremental delay, which is a more dominant component of total control delay under heavy traffic conditions. Hence, the analysis period has a significant impact on the service measure for high demand (see Table A-12).

Cycle length has a low to moderate degree of sensitivity on the estimated intersection delay (see Table A-13). Local information is usually available to the analyst. Local policy that establishes maximums and minimums for nearby intersections can also be readily referenced rather than using a default from the HCM.

Table A-11. PHF Sensitivity on delay at signals.

Measures	Low Demand				Average Demand				High Demand			
	250 (veh/approach)				700 (veh/approach)				900 (veh/approach)			
PHF	0.6	0.8	0.92	1	0.6	0.8	0.92	1	0.6	0.8	0.92	1
% Default Change	-35	-13	0	9	-35	-13	0	9	-35	-13	0	9
Intersection delay s/veh	20.2	19.5	19.2	19.1	95.7	34.3	28.8	27.0	253.0	100.1	66.8	47.3
LOS	C	B	B	B	F	C	C	C	F	F	E	D
% Change in Results	5	2	0	-1	232	19	0	-6	279	50	0	-29

Table A-12. Length of analysis period sensitivity on delay at signals.

Measures	Low Demand				Average Demand				High Demand			
	250 (veh/approach)				700 (veh/approach)				900 (veh/approach)			
Analysis period	0.25	0.5	0.75	1	0.25	0.5	0.75	1	0.25	0.5	0.75	1
% Default Change	0	100	200	300	0	100	200	300	0	100	200	300
Intersection delay s/veh	19.2	19.2	19.2	19.2	28.8	28.8	28.8	28.8	66.8	78.8	88.2	96.3
LOS	B	B	B	B	C	C	C	C	E	E	F	F
% Change in Results	0	0	0	0	0	0	0	0	0	18	32	44

Table A-13. Cycle length sensitivity on delay at signals.

Measures	Low Demand			Average Demand			High Demand		
	250 (veh/approach)			700 (veh/approach)			900 (veh/approach)		
Cycle length, s	56	70	84	64	80	96	88	110	132
% Default Change	-20	0	20	-20	0	20	-20	0	20
Intersection delay s/veh	16.5	19.6	22.0	27.1	28.8	33.1	71.0	66.8	69.9
LOS	B	B	C	C	C	C	E	E	E
% Change in Results	-16	0	12	-6	0	15	6	0	5

Depending on the yellow and all-red intervals, lost time can vary from 1 to 7 s per phase. The smaller the total lost time, the larger the intersection's throughput capacity. The sensitivity analysis indicates that the benefit of reduced lost time increases with increased traffic demand. Low to moderate change in delay occurs with changing demand (see Table A-14).

There are six arrival types in the signalized methodology representing poor to exceptional progression quality. The arrival types are used in calculation of the progression factor, which directly adjusts the uniform delay component. Delay was found to be highly sensitive to arrival types 1, 5, and 6 under all three demand levels (see Table A-15).

Unit extension time is used in the estimation of the incremental delay calibration factor which is a term in the incremental delay calculation. Its impact on the service measure is less than 5% (see Table A-16).

Actuated control adjustment factor is a function of the degree of saturation and the unit extension time, and is used in the estimation of the incremental delay. This factor has a low impact on the incremental delay under the heavy congestion levels and a moderate impact under the lower demand levels. Consequently, its effect on the intersection delay is low (see Table A-17).

Upstream filtering accounts for the effect of metering arrivals from upstream signals. The default value is 1.00 for analysis of an isolated intersection. The HCM provides an equation to estimate the I-values for non-isolated intersections. The intersection delay has low to moderate sensitivity for average to high demand conditions (see Table A-18).

Table A-14. Lost time sensitivity on delay at signals.

Measures	Low Demand				Average Demand				High Demand			
	250 (veh/approach)				700 (veh/approach)				900 (veh/approach)			
Total lost time, s	8	12	16	20	8	12	16	20	8	12	16	20
% Default Change	-50	-25	0	25	-50	-25	0	25	-50	-25	0	25
Intersection delay s/veh	16.5	19.6	22.0	27.1	28.8	33.1	71.0	66.8	69.9	16.5	19.6	22.0
LOS	B	B	B	B	C	C	C	C	D	E	E	F
% Change in Results	-8	-4	0	4	-13	-7	0	12	-21	-12	0	14

Table A-15. Arrival type sensitivity on delay at signals.

Measures	Low Demand					
	250 (veh/approach)					
Arrival type	1	2	3	4	5	6
% Default Change	-67	-33	0	33	67	100
Intersection delay s/veh	24.2	20.3	19.2	18.8	14.1	11.6
LOS	C	C	B	B	B	B
% Change in Results	26	6	0	-2	-27	-40
Measures	Average Demand					
	700(veh/approach)					
Arrival type	1	2	3	4	5	6
% Default Change	-67	-33	0	33	67	100
Intersection delay s/veh	35.9	30.3	28.8	28.0	21.7	18.1
LOS	D	C	C	C	C	B
% Change in Results	25	5	0	-3	-25	-37
Measures	High Demand					
	900(veh/approach)					
Arrival type	1	2	3	4	5	6
% Default Change	-67	-33	0	33	67	100
Intersection delay s/veh	78.2	69.4	66.8	65.3	55.3	49.6
LOS	E	E	E	E	E	D
% Change in Results	17	4	0	-2	-17	-26

Table A-16. Unit extension time sensitivity on delay at signals.

Measures	Low Demand				Average Demand				High Demand			
	250 (veh/approach)				700 (veh/approach)				900 (veh/approach)			
Unit extension, s	2	3	4	5	2	3	4	5	2	3	4	5
% Default Change	-33	0	33	67	-33	0	33	67	-33	0	33	67
Intersection delay s/veh	19.2	19.2	19.2	19.5	28.2	28.8	29.1	29.7	66.6	66.8	66.9	67.1
LOS	B	B	B	B	C	C	C	C	E	E	E	E
% Change in Results	0	0	0	2	-2	0	1	3	0	0	0	0

Table A-17. K-factor sensitivity on delay at signals.

Measures	Low Congestion			Average Congestion			High Congestion		
	v/c = 0.7			v/c = 0.8			v/c = 0.9		
K factor	0.35	0.4	0.45	0.35	0.4	0.45	0.4	0.45	0.5
% Default Change	-13	0	13	-13	0	13	-11	0	11
Intersection delay s/veh	2.97	3.38	3.79	4.93	5.59	6.25	10.78	11.89	12.97
LOS									
% Change in Results	-12	0	12	-12	0	12	-9	0	9

Table A-18. Filtering factor sensitivity on delay at signals.

Measures	Low Demand				Average Demand				High Demand			
	250 (veh/approach)				700 (veh/approach)				900 (veh/approach)			
Filtering factor	0.25	0.5	0.75	1	0.25	0.5	0.75	1	0.25	0.5	0.75	1
% Default Change	-75	-50	-25	0	-75	-50	-25	0	-75	-50	-25	0
Intersection delay s/veh	19.2	19.2	19.2	19.2	26.0	27.0	27.9	28.8	52.4	58.3	62.8	66.8
LOS	B	B	B	B	C	C	C	C	D	E	E	E
% Change in Results	0	0	0	0	-10	-6	-3	0	-22	-13	-6	0

The signalized method allows the user to override the estimated adjusted saturation flow rate with field measured values. The saturation flow rate parameter has a low degree of sensitivity under low and average traffic conditions and a significant degree of sensitivity when traffic demand approaches or exceeds saturation (see Table A-19). At oversaturation levels, the saturation flow rate should not be defaulted. If field-measured values are not available, it should be estimated from the base saturation flow rate and adjustment factors as detailed in the HCM.

When base saturation flow rate cannot be measured in the field, a default value is used. A default value of 1,900 is often used in analyses. The sensitivity results indicate that this input parameter has a low impact on delay under low demand, a moderate impact at average demand, and a significant impact under congested conditions (see Table A-20).

The base saturation flow rate is adjusted by the lane width, %HV, percent grade, bus, pedestrian, and parking movements, and lane utilization. A decrease in the lane width decreases the saturation flow and results in a similar sensitivity to that illustrated for the base saturation flow (see Table A-21).

Increasing %HV results in a decrease in the saturation flow rate. Fifteen %HV was found to increase the delay by as much as 60% under high demand conditions (see Table A-22). This parameter has a much more significant effect on the signal operation than other facilities types.

According to its adjustment equation, every 1% in approach grade results in a 0.5% reduction in saturation flow rate, which consequently results in a low to moderate impact on the delay (see Table A-23).

Table A-19. Adjusted saturation flow sensitivity on delay at signals.

Measure	Low Demand				Average Demand				High Demand			
	250 (veh/approach)				700 (veh/approach)				900 (veh/approach)			
Adjusted sat. flow, pc/h	1500	1600	1700	1800	1500	1600	1700	1800	1500	1600	1700	1800
% Default Change	-12	-6	0	6	-12	-6	0	6	-12	-6	0	6
Intersection delay s/veh	19.2	19.1	19.0	19.0	28.0	26.9	26.2	25.6	58.3	48.3	43.4	40.5
LOS	B	B	B	B	C	C	C	C	E	D	D	D
% Change in Results	1	1	0	0	7	3	0	-2	34	11	0	-7

Table A-20. Base saturation flow sensitivity on delay at signals.

Measures	Low Demand				Average Demand				High Demand			
	250 (veh/approach)				700 (veh/approach)				900 (veh/approach)			
Base Sat flow, pc/h	1700	1800	1900	2000	1700	1800	1900	2000	1700	1800	1900	2000
% Default Change	-11	-5	0	5	-11	-5	0	5	-11	-5	0	5
Intersection delay s/veh	19.4	19.3	19.2	19.2	32.6	26.9	28.8	27.7	103.0	82.2	66.8	55.3
LOS	B	B	B	B	C	C	C	C	F	F	E	E
% Change in Results	1	1	0	0	13	-7	0	-4	54	23	0	-17

Table A-21. Lane width sensitivity on delay at signals.

Measures	Low Demand				Average Demand				High Demand			
	250 (veh/approach)				700 (veh/approach)				900 (veh/approach)			
Lane width, ft	9	10	12	14	9	10	12	14	9	10	12	14
% Default Change	-25	-17	0	17	-25	-17	0	17	-25	-17	0	17
Intersection delay s/veh	19.4	19.4	19.2	19.2	33.1	31.3	28.8	27.1	102.3	88.1	66.8	52.5
LOS	B	B	B	B	C	C	C	C	F	F	E	D
% Change in Results	1	1	0	0	15	9	0	-6	53	32	0	-21

Table A-22. %HV sensitivity on delay at signals.

Measures	Low demand				Average demand				High demand			
	250 (veh/approach)				700 (veh/approach)				900 (veh/approach)			
%HV	0	2	15	25	0	2	15	25	0	2	15	25
% Default Change	-100	0	650	1150	-100	0	650	1150	-100	0	650	1150
Intersection delay s/veh	19.2	19.2	19.4	19.6	28.2	28.8	34.0	41.5	61.7	66.8	108.4	147.3
LOS	B	B	B	B	C	C	C	D	E	E	F	F
% Change in Results	0	0	1	2	-2	0	18	44	-8	0	62	121

Table A-23. % Approach grade sensitivity on delay at signals.

Measures	Low Demand				Average Demand				High Demand			
	250 (veh/approach)				700 (veh/approach)				900 (veh/approach)			
Grade, %	-3	0	6	10	-3	0	6	10	-3	0	6	10
% Default Change												
Intersection delay s/veh	19.2	19.2	19.3	19.3	28.3	28.8	29.7	30.6	62.9	66.8	75.2	78.4
LOS	B	B	B	B	C	C	C	C	E	E	E	E
% Change in Results	0	0	1	1	-2	0	3	6	-6	0	13	17

An increase in parking maneuvers results in a decrease in the saturation flow rate. The sensitivity analyses indicate that parking maneuvers have a moderate degree of sensitivity and that the impact is more significant under the high traffic demand conditions (see Table A-24).

Bus frequency accounts for the effect of bus blockage on the saturation flow. An increase in bus frequency results in a decrease in the saturation flow rate and like the parking maneuvers, it has a low to moderate degree of sensitivity on delay (see Table A-25).

Pedestrian flow rate is used in the estimation of pedestrian clearance interval as well as the estimation of saturation flow rate. An increase in pedestrian flow rates results in a decrease in the saturation flow rate. Pedestrian flow rate was found to have a low degree of sensitivity (see Table A-26).

The HCM recognizes that lane utilization has a significant degree of sensitivity and thus recommends that the parameter should be measured in the field when feasible. The sensitivity analyses

Table A-24. Parking maneuver sensitivity on delay at signals.

Measures	Low Demand				Average Demand				High Demand			
	250 (veh/approach)				700 (veh/approach)				900 (veh/approach)			
Parking maneuvers	0	8	15	30	0	8	15	30	0	8	15	30
% Default Change	-100	0	88	275	-100	0	88	275	-100	0	88	275
Intersection delay s/veh	19.1	19.2	19.3	19.3	27.3	28.8	29.3	30.5	51.9	66.8	71.6	77.1
LOS	B	B	B	B	C	C	C	C	D	E	E	E
% Change in Results	-1	0	1	1	-5	0	2	6	-22	0	7	15

Table A-25. Bus frequency sensitivity on delay at signals.

Measures	Low Demand				Average Demand				High Demand			
	250 (veh/approach)				700 (veh/approach)				900 (veh/approach)			
Bus frequency	0	2	15	30	0	2	15	30	0	2	15	30
% Default Change	-100	0	650	1400	-100	0	650	1400	-100	0	650	1400
Intersection delay s/veh	19.2	19.2	19.3	19.3	28.7	28.8	29.4	30.3	65.9	66.8	73.5	75.7
LOS	B	B	B	B	C	C	C	C	E	E	E	E
% Change in Results	0	0	1	1	0	0	2	5	-1	0	10	13

Table A-26. Pedestrian sensitivity on delay at signals.

Measures	Low Demand				Average Demand				High Demand			
	250 (veh/approach)				700 (veh/approach)				900 (veh/approach)			
Pedestrians	50	100	200	400	50	100	200	400	50	100	200	400
% Default Change	0	100	300	700	0	100	300	700	0	100	300	700
Intersection delay s/veh	19.2	19.3	19.3	19.3	28.8	28.9	29.1	29.5	66.8	68.0	70.5	74.8
LOS	B	B	B	B	C	C	C	C	E	E	E	E
% Change in Results	0	1	1	1	0	0	1	2	0	2	6	12

Table A-27. Lane utilization sensitivity on delay at signals.

Measures	Low Demand				Average Demand				High Demand			
	250 (veh/approach)				700 (veh/approach)				900 (veh/approach)			
Lane utilization	0.85	0.90	0.95	1.00	0.85	0.90	0.95	1.00	0.85	0.90	0.95	1.00
% Default Change	-11	-5	0	5	-11	-5	0	5	-11	-5	0	5
Intersection delay s/veh	19.4	19.3	19.2	19.2	32.7	30.3	28.8	27.7	94.7	75.7	66.8	55.7
LOS	B	B	B	B	C	C	C	C	F	E	E	E
% Change in Results	1	1	0	0	14	5	0	-4	42	13	0	-17

show that a 10% change in the lane utilization can result in 15 to 40% change in the delay (see Table A-27).

Pedestrians

HiCAP was utilized to perform sensitivity analyses for four input parameters in the Pedestrian methodologies. The effects of each parameter on the service measure and subsequently, level-of-service, were evaluated under low, average, and high pedestrian demand conditions. Each sensitivity analysis began with a base scenario. Input values for the target parameter were varied to record its effects. The input parameters are listed in Table A-28 followed by a summary of the base scenarios.

Base Scenario

Uninterrupted-flow pedestrian facilities

- Total width of sidewalk, ft = 7.0 (no buffer zone)
- Total width of obstruction, ft = 0.0

Table A-28. Summary of pedestrian input parameters.

Input Parameter	Default Value	Methodology	HCM Source
Effective sidewalk width (ft)	5.0 or 7.0	Uninterrupted-flow pedestrian facilities	Exh. 11-13
Street corner radius (ft)	45.0 or 25.0	Interrupted-flow pedestrian facilities – Street Corners at Signalized Intersections	Exh. 11-14
Pedestrian walking speed (ft/s)	4.0	Interrupted-flow pedestrian facilities – Crosswalk at Signalized Intersections	Exh. 11-12
Pedestrian start-up time (s)	3.0	Interrupted-flow pedestrian facilities – Crosswalk Unsignalized Intersections	Exh. 11-12

94 Default Values for Highway Capacity and Level of Service Analyses

- Low demand—Peak 15-minute flow, pedestrians/15-min = 200
- Average demand—Peak 15-minute flow, pedestrians/15-min = 800
- High demand—Peak 15-minute flow, pedestrians/15-min = 1500
- Default parameter evaluated in this methodology: effective width of sidewalk

The service measure is pedestrian unit flow rate. It is computed according to the following equation.

$$v_p = \frac{v_{15}}{15 * W_E} \quad (\text{HCM Eq. 18-2})$$

Where

- v_p = pedestrian unit flow rate (p/min/ft),
- v_{15} = peak 15-min flow rate (p/15-min), and
- W_E = effective walkway width (ft).

Interrupted-flow pedestrian facilities—street corners at signalized intersections

- Cycle length at signalized intersection, $s = 80.0$
- Red phase and effective green, $s = 40.0$
- Width of minor/major street sidewalk, $ft = 25.0$
- Curb radius, $ft = 25.0$
- Low demand—Peak 15-minute flow, pedestrians/15-min = 100 (same for all directions)
- Average demand—Peak 15-minute flow, pedestrians/15-min = 200 (same for all directions)
- High demand—Peak 15-minute flow, pedestrians/15-min = 450 (same for all directions)

The default parameter evaluated in this methodology is street corner radius.

The service measure is circulation area. It is computed according to the following equation.

$$M = \frac{TS_c}{4v_{tot}} \quad (\text{HCM Eq. 18-10})$$

Where

- M = circulation area per pedestrian (ft^2/p);
- TS_c = total time-space available for circulating pedestrians (ft^2-s); and
- v_{tot} = total number of circulating pedestrians in one cycle = $v_{ci} + v_{co} + v_{di} + v_{do} + v_{a,b}$, as shown in Exhibits 18-11 and 18-12 (p/cycle).

Interrupted-flow pedestrian facilities—crosswalks at signalized intersections

- Cycle length at signalized intersection, $s = 80.0$
- Red phase and effective green, $s = 40.0$
- Walking speed, $ft/s = 4.0$
- Length of crosswalk, $ft = 50.0$
- Effective crosswalk width, $ft = 12.0$
- WALK phase, $s = 40.0$
- Flashing Don't Walk phase, $s = 0.0$
- Number of conflicting right-turn vehicles, $veh/hr = 0$
- Low demand—Peak 15-minute flow, pedestrians/15-min = 100 (same for all directions)
- Average demand—Peak 15-minute flow, pedestrians/15-min = 200 (same for all directions)
- High demand—Peak 15-minute flow, pedestrians/15-min = 450 (same for all directions)

The default parameter evaluated in this methodology is pedestrian walking speed.

The service measure is circulation area. It is computed according to the following equation.

$$M = \frac{TS}{T} \tag{HCM Eq. 18-15}$$

Where

- M = circulation area per pedestrian (ft²/p),
- TS = time-space (ft²-s), and
- T = total crosswalk occupancy time (p-s).

Interrupted-flow pedestrian facilities—street corners at unsignalized intersections

- Total width of crosswalk, ft = 12.0
- Effective width of crosswalk, ft = 12.0
- Pedestrian walking speed, ft/s = 4.0
- Pedestrian start-up time, s = 3.0
- Length of crosswalk, ft = 36.0
- Conflicting vehicle flow rate, veh/hr = 500
- Low demand—Peak 15-minute flow, pedestrians/15-min = 100
- Average demand—Peak 15-minute flow, pedestrians/15-min = 200
- High demand—Peak 15-minute flow, pedestrians/15-min = 450

The default parameter evaluated in this methodology is pedestrian start-up time.

The service measure is average pedestrian delay. It is computed according to the following equation.

$$d_p = \frac{1}{v}(e^{vt_G} - vt_G - 1) \tag{HCM Eq. 18-21}$$

Where

- d_p = average pedestrian delay (s),
- v = vehicular flow rate (veh/s), and
- t_G = group critical gap from Equation 18-19 (s).

Findings and Recommendations

Effective sidewalk width at uninterrupted pedestrian facilities was found to have a significant impact on level of service (see Table A-29). The trend is the same in all demand levels examined.

Street corner radius, which is used to assess street corners at signalized intersections, directly affects the computation of available time-space. An increase in the corner radius results in a reduction in circulation (see Table A-30). This reduction in circulation occurs because as the larger corner radius (for turning vehicles) increases, the sidewalk area at the corner decreases. The street corner radius input parameter has a significant degree of sensitivity at all demand levels.

Table A-29. Effective width sensitivity on pedestrian flow at crosswalks.

Measure	Low Demand					Average Demand					High Demand				
	Volume = 200					Volume = 800					Volume = 1500				
Effective Width, ft	3	5	7	10	15	3	5	7	10	15	3	5	7	10	15
% Default Change	-57	-29	0	43	114	-57	-29	0	43	114	-57	-29	0	43	114
Ped Flow, p/min/ft	4.4	2.7	1.9	1.3	0.9	17.8	10.7	7.6	5.3	3.6	33.3	20	14.3	10	6.7
LOS	A	A	A	A	A	E	D	C	B	A	F	E	D	C	B
% Change in Results	132	42	0	-32	-53	134	41	0	-30	-53	133	40	0	-30	-53

Table A-30. Corner radius sensitivity on area at crosswalks at signals.

Measure	Low Demand				Average Demand				High Demand			
	Volume = 100				Volume = 200				Volume = 450			
Corner Radius, ft	15	25	35	50	15	25	35	50	15	25	35	50
% Default Change	-40	0	40	100	-40	0	40	100	-40	0	40	100
Circulation Area ft ² /p	245	216	158	34	125	105	76	15	53	44	31	4
LOS	A	A	A	C	A	A	A	E	B	B	C	F
% Change in Results	14	0	-27	-84	18	0	-28	-86	20	0	-29	-91

Pedestrian walking speed at signalized intersection crosswalks inversely affects the estimation of circulation area. Within the input range investigated, the service measure is highly sensitive to this input parameter (see Table A-31). It should be noted that the effect appears to slightly decrease as the pedestrian demand increases.

Pedestrian start-up time at unsignalized intersection crosswalks has a significant impact on the service measure for all demand levels. The impact is the most dramatic at the average demand level (see Table A-32).

Bicycles

HiCAP was used to perform sensitivity analyses for three input parameters in the Bicycle methodologies. The effects of each parameter on the service measure were evaluated under low, average, and high bicycle demand conditions. Each sensitivity analysis began with a base scenario. Input values for the target parameter were varied to record its effects. The study parameters are listed in Table A-33, followed by a description of the base scenarios.

Base Scenario

Two-lane, two-way, exclusive off-street bicycle path

- Bicycle lane width, ft = 8.0
- Bicycle PHF = 0.80

Table A-31. Walking speed sensitivity area at crosswalks.

Measures	Low Demand				Average Demand				High Demand			
	Volume = 100				Volume = 200				Volume = 450			
Walking Speed, ft/s	2	4	5	6	2	4	5	6	2	4	5	6
%Default Change	-50	0	25	50	-50	0	25	50	-50	0	25	50
Circulation Area, ft ² /p	31.8	68.2	83.2	96.5	15.4	32.2	38.9	44.7	6.3	12.5	14.8	16.8
LOS	C	A	A	A	D	C	C	B	F	E	E	D
% Change in Results	-53	0	22	41	-52	0	21	39	-50	0	18	34

Table A-32. Pedestrian start-up time sensitivity on delay at signals.

Measure	Low Demand				Average Demand				High Demand			
	Volume = 100				Volume = 200				Volume = 450			
Pedestrian Start-Up, s	1.8	2	3	4	1.8	2	3	4	1.8	2	3	4
%Default Change	-40	-33	0	33	-40	-33	0	33	-40	-33	0	33
Average Delay, s/ped	14.3	15	18.9	23.6	14.3	15	29.1	35.6	22.6	23.6	29.1	35.6
LOS	C	C	C	D	C	C	D	E	D	D	D	E
% Change in Results	-24	-21	0	25	-51	-48	0	22	-22	-19	0	22

Table A-33. Summary of input parameters for bicycle paths.

Input Parameter	Default Value	Methodology	HCM Source
Bicycle path width (ft)	8.0	Two-lane, two-way, exclusive off-street bicycle path	Exh. 11-19
PHF	0.80	Two-lane, two-way, exclusive off-street bicycle path	Exh. 11-19
Bicycle speed (mph)	15.0	Interrupted-flow bicycle lanes along urban streets	Exh. 11-19

- Directional bicycle split in the subject direction = 0.50 (resulting in equal bicycle flow rate in both subject and opposing directions)
- Low demand—bicycle volume, bicycles/hr = 100
- Average demand—bicycle volume, bicycles/hr = 200
- High demand—bicycle volume, bicycles/hr = 400

Default parameters evaluated in this methodology: bicycle lane width, PHF.

The service measure is the number of events computed according to the following equations:

$$F_p = 0.188v_s \quad (\text{HCM Eq. 19-1})$$

$$F_m = 2v_o \quad (\text{HCM Eq. 19-2})$$

$$F = 0.5F_m + F_p \quad (\text{HCM Eq. 19-3})$$

Where

F_p = number of passing events (with bicyclists in same direction) (events/hr);

F_m = number of opposing events (with bicyclists in opposing direction) (events/hr);

F = total number of events on path (events/h), with a weighting factor of 0.5 for meeting events;

v_s = flow rate of bicycles in subject direction (bicycles/hr); and

v_o = flow rate of bicycles in opposing direction (bicycles/hr).

Interrupted-flow bicycle lanes along urban streets

- Cycle length at signalized intersections, $s = 100.0$
- g/C ratio at signalized intersections = 0.30
- Link length, $mi = 0.30$ (distance between signalized intersections)
- Bicycle running speed, $mph = 15.0$
- Low demand—bicycle volume, bicycles/hr = 100
- Average demand—bicycle volume, bicycles/hr = 200
- High demand—bicycle volume, bicycles/hr = 400

The default parameter evaluated in this methodology is bicycle running speed.

The service measure is bicycle travel speed. It is computed according to the following equation.

$$S_{ats} = \frac{L_T}{\left(\sum \frac{L_i}{S_i} + \frac{\sum d_j}{3600} \right)} \quad (\text{HCM Eq. 19-11})$$

Where

S_{ats} = bicycle travel speed (km/hr),

L_T = total length of urban street under analysis (km),

L_i = length of segment i (km),

S_i = bicycle running speed over segment i (km/hr), and

d_j = average bicycle delay at intersection j (s).

Findings and Recommendations

Two-lane, two-way, exclusive off-street bicycle path width does not have any impact on level of service (see Table A-34). A closer examination of the methodologies indicates that this parameter does not enter into the computations, and its default value of 8.0 ft was derived from the AASHTO’s Guide for Development of Bicycle Facilities.

Two-lane, two-way, exclusive off-street bicycle path PHF directly affects bicycle volume and, subsequently, level of service. The service measure has a significant sensitivity to the PHF for all three demand levels (see Table A-35).

Interrupted-flow bicycle lane running speed along urban streets greatly affects the estimation of bicycle travel speed. Within the practical range of this parameter, the performance measure has a significant degree of sensitivity to the running speed for all demand levels (see Table A-36).

Two-Lane Highways

In HCM 2000, two methodologies are provided to analyze a two-lane highway segment: a two-way analysis method and a directional analysis method. Because the directional analysis method

Table A-34. Bicycle path width sensitivity on number of events.

Measures	Low Demand				
	Volume = 100				
Bicycle Path Width, ft	3	5	8	10	14
% Default Change	-63	-38	0	25	75
Number of Events	74	74	74	74	74
LOS	C	C	C	C	C
% Change in Results	0	0	0	0	0
Measures	Average Demand				
	Volume = 200				
Bicycle Path Width, ft	3	5	8	10	14
% Default Change	-63	-63	-63	-63	-63
Number of Events	149	149	149	149	149
LOS	C	C	C	C	C
% Change in Results	0	0	0	0	0
Measures	High Demand				
	Volume = 400				
Bicycle Path Width, ft	3	5	8	10	14
% Default Change	-63	-63	-63	-63	-63
Number of Events	297	297	297	297	297
LOS	C	C	C	C	C
% Change in Results	0	0	0	0	0

Table A-35. PHF sensitivity on number of events at bike paths.

Measure	Low Demand				Average Demand				High Demand			
	Volume = 100				Volume = 200				Volume = 400			
Bicycle PHF	0.6	0.8	0.9	1	0.6	0.8	0.9	1	0.6	0.8	0.9	1
% Default Change	-25	0	13	25	-25	0	13	25	-25	0	13	25
Number of events	99	74	66	59	198	149	132	119	396	297	264	238
LOS	C	C	C	B	F	D	D	D	F	F	F	F
% Change in Results	34	0	-11	-20	33	0	-11	-20	33	0	-11	-20

Table A-36. Bicycle running speed sensitivity on travel speed at bike paths.

Measure	Low Demand				Average Demand				High Demand			
	Volume = 100				Volume = 200				Volume = 400			
Bicycle Running Speed, mph	10	15	20	25	10	15	20	25	10	15	20	25
% Default Change	-33	0	33	67	-33	0	33	67	-33	0	33	67
Average Travel Speed, mph	7.7	10.4	12.5	14.3	7.6	10.2	12.3	14.0	7.4	9.8	11.7	13.3
LOS	C	B	B	A	C	B	B	B	C	B	B	B
% Change in Results	-26	0	21	38	-25	0	20	37	-25	0	20	35

is more appropriate for steep grades and for segments containing passing lanes, it was used to evaluate the length of passing lane parameter. Other parameters were analyzed using the two-way method. Table A-37 lists 11 input parameters that have default values in HCM 2000. Of the 11 input parameters, the length of analysis period and directional split were not included in the sensitivity analyses. The length of analysis period is discussed in the HCM for guidance purposes and its default value does not play any role in the methodologies. The directional split is used by the two-way methodology to compute traffic volume in the peak direction, but this parameter does not have any impact on the service measure. Moreover, directional split is readily derived from volumes. Thus, it should not be defaulted in an HCM analysis.

Consistent with the previous methodologies, the effects of the nine parameters on the service measure were evaluated under low, average, and high traffic demand conditions. Each sensitivity analysis began with a base scenario. Input values for the target input parameter were varied to record its effects. The input parameters are listed in Table A-37, followed by a summary of the base scenarios.

Base Scenario

Two-way methodology

- Highway class = 1
- Terrain = Level
- Average lane width, ft = 12.0
- Average shoulder width, ft = 6.0
- Segment length, mi = 3.0
- Directional split = 60/40
- PHF = 0.92
- Percent of trucks and buses = 2%

Table A-37. Summary of input parameters factors for two-lane highways.

Input Parameter	Default Value	Methodology	HCM Source
Lane width (ft)	12.0	Two-Way /Directional methodology	Exh. 12-9
Shoulder width (ft)	6.0	Two-Way /Directional methodology	Exh. 12-9
Access point density (points/mi)	8/16/25	Two-Way/Directional methodology	Exh. 12-4
Specific grade or general terrain	Level	Two-Way/Directional methodology	Exh. 12-9
Percent no-passing	20%/50%/80%	Level/rolling/mountainous	Exh. 12-11
Length of passing lanes (mi)	0.5/0.75/1.0/2.0	Directional methodology	Exh. 12-12
Analysis Period Length (min)	15	N/A	Exh. 12-9
PHF	0.88/0.92	Two-Way /Directional methodology	Exh. 12-9
Directional Split	60/40 or 80/20	Two-Way methodology	Exh. 12-13
%HV (trucks/buses)	14%/2%	Two-Way /Directional methodology	Exh. 12-14
%HV (RVs)	4%/0%	Two-Way /Directional methodology	Exh. 12-14

- Percent of recreational vehicles = 0%
- Percent of no-passing zone = 20%
- Access point density, points/mi = 16
- Base free-flow speed, mph = 65
- Low demand—two-way traffic volume, veh/hr = 500
- Average demand—two-way traffic volume, veh/hr = 1,000
- High demand—two-way traffic volume, veh/hr = 1,600

The input parameters evaluated in this methodology are lane width, shoulder width, access point density, grade, percent of no-passing zone, length of passing lane, PHF, percent of trucks and buses, and percent of recreational vehicles.

The service measures are percent time spent following and average travel speed. They are computed according to the following equations.

$$ATS = FFS - 0.00776v_p - f_{np} \quad (\text{HCM Eq. 20-5})$$

Where

ATS = average travel speed for both directions of travel combined (mph),
 f_{np} = adjustment for percentage of no-passing zones (see Exhibit 20-11), and
 v_p = passenger-car equivalent flow rate for peak 15-min period (pc/hr).

$$PTSF = BPTSF + f_{d/np} \quad (\text{HCM Eq. 20-6})$$

Where

PTSF = percent time-spent-following,
 BPTSF = base percent time-spent-following for both directions of travel combined (use Equation 20-7), and
 $f_{d/np}$ = adjustment for the combined effect of the directional distribution of traffic and of the percentage of no-passing zones on percent time-spent-following.

Directional methodology

- Highway class = 1
- Terrain = Level
- Average lane width, ft = 12.0
- Average shoulder width, ft = 6.0
- Segment length, mi = 3.0
- PHF = 0.92
- Percent of trucks and buses = 2%
- Percent of recreational vehicles = 0%
- Percent of no-passing zone = 20%
- Access point density, points/mi = 16
- Base free-flow speed, mph = 65
- Length of segment upstream of passing lane, mi = 0.3
- Length of passing lane, mi = 0.5
- Low demand—subject/opposing traffic volume, veh/hr = 200/133
- Average demand—subject/opposing traffic volume, veh/hr = 400/267
- High demand—subject/opposing traffic volume, veh/hr = 700/467

The default parameter evaluated in this methodology is the length of passing lane.

The service measures are average travel speed and percent time-spent-following. They are computed according to the following equations.

$$ATS_d = FFS_d - 0.00776(v_d + v_o) - f_{np} \quad \text{(HCM Eq. 20-15)}$$

Where

- ATS_d = average travel speed in the analysis direction (mph),
- FFS_d = free-flow speed in the analysis direction (mph),
- v_d = passenger-car equivalent flow rate for the peak 15-min period in the analysis direction (pc/hr),
- v_o = passenger-car equivalent flow rate for the peak 15-min period in the opposing direction (pc/hr), determined from Equation 20-13; and
- f_{np} = adjustment for percentage of no-passing zones in the analysis direction (see Exhibit 20-19).

$$PTSF_d = BPTSF_d + f_{np} \quad \text{(HCM Eq. 20-16)}$$

Where

- $PTSF_d$ = percent time-spent-following in the direction analyzed,
- $BPTSF_d$ = base percent time-spent-following in the direction analyzed, and
- f_{np} = adjustment for percentage of no-passing zones in the analysis direction (see Exhibit 20-20).

Findings and Recommendations

Lane width does not enter into the calculation of percent time-spent-following; therefore, it does not affect this service measure. It does have an impact on the travel speed, but the impact is very low (less than 5%) in all three demand levels (see Table A-38).

Shoulder width has no impact on percent time-spent-following and a low impact on travel speed (see Table A-39).

Access point density is not used to calculate percent time-spent-following and has a low impact on travel speed. A 150% increase in access point density results in approximately 10% change in the average travel (see Table A-40).

The two-way methodology only provides adjustment factors for level and rolling terrain. Mountainous terrain can be analyzed as specific grades using the directional method. The analysis results indicate that *terrain* has a low degree of sensitivity, less than 5% impact on either service measures, and becomes less sensitive as the traffic volume increases (see Table A-41).

Table A-38. Lane width sensitivity on travel speed at two-lane highways.

Measures	Low Demand				Average Demand				High Demand			
	2-Way Volume = 500				2-Way Volume = 1000				2-Way Volume = 1600			
Lane width, ft	9	10	11	12	9	10	11	12	9	10	11	12
% Default Change	-25	-17	-8	0	-25	-17	-8	0	-25	-17	-8	0
%Time-spent Following	49.6	49.6	49.6	49.6	67.3	67.3	67.3	67.3	81.2	81.2	81.2	81.2
% Change in Results	0	0	0	0	0	0	0	0	0	0	0	0
Average Travel Speed, mph	52.9	54	54.7	55.1	49.4	50.5	51.2	51.6	44.7	45.8	46.5	46.9
% Change in Results	-4	-2	-1	0	-4	-2	-1	0	-5	-2	-1	0
LOS	B	B	B	B	D	D	D	D	E	E	E	E

Table A-39. Shoulder width sensitivity on travel speed for two-lane highways.

Measures	Low Demand				Average Demand				High Demand			
	2-Way Volume = 500				2-Way Volume = 1000				2-Way Volume = 1600			
Shoulder width, ft	0	2	4	6	0	2	4	6	0	2	4	6
% Default Change	-100	-67	-33	0	-100	-67	-33	0	-100	-67	-33	0
% Time-spent-following	49.6	49.6	49.6	49.6	67.3	67.3	67.3	67.3	81.2	81.2	81.2	81.2
% Change in Results	0	0	0	0	0	0	0	0	0	0	0	0
Average Travel Speed, mph	50.9	52.5	53.8	55.1	47.4	49	50.3	51.6	42.7	44.3	45.6	46.9
% Change in Results	-8	-5	-2	0	-8	-5	-3	0	-9	-6	-3	0
LOS	B	B	B	B	D	D	D	D	E	E	E	E

Table A-40. Access points sensitivity on travel speed at two-lane highways.

Measures	Low Demand				
	2-Way Volume = 500				
Access Point Density, pts/mi	0	8	16	25	40
% Default Change	-100	-50	0	56	150
%Time-spent-following	49.6	49.6	49.6	49.6	49.6
% Change in Results	0	0	0	0	0
Average Travel Speed, mph	59.1	57.1	55.1	52.8	49.1
% Change in Results	7	4	0	-4	-11
LOS	B	B	B	B	C
Measures	Average Demand				
	2-Way Volume = 1000				
Access Point Density, pts/mi	0	0	0	0	0
% Default Change	-100	-100	-100	-100	-100
%Time-spent-following	67.3	67.3	67.3	67.3	67.3
% Change in Results	0	0	0	0	0
Average Travel Speed, mph	55.6	53.6	51.6	49.3	45.6
% Change in Results	8	8	8	8	8
LOS	D	D	D	D	D
Measures	High Demand				
	2-Way Volume = 1600				
Access Point Density, pts/mi	0	0	0	0	0
% Default Change	-100	-100	-100	-100	-100
%Time-spent-following	81.2	81.2	81.2	81.2	81.2
% Change in Results	0	0	0	0	0
Average Travel Speed, mph	50.9	48.9	46.9	44.7	40.9
% Change in Results	9	9	9	9	9
LOS	E	E	E	E	E

Table A-41. Terrain sensitivity on travel speed at two-lane highways.

Measures	Low Demand			Average Demand			High Demand		
	2-Way Volume = 500			2-Way Volume = 1000			2-Way Volume = 1600		
Terrain (1)	M	R	L	M	R	L	M	R	L
% Default Change									
%Time-spent-following		51.7	49.6		69.4	67.3		81.2	81.2
% Change in Results		4	0		3	0		0	0
Average Travel Speed, mph		54.8	55.1		51	51.6		46.7	46.9
% Change in Results		-1	0		-1	0		0	0
LOS		C	B		D	D		E	E

(1) M = Mountain; R = Rolling, L = Level

Table A-42. Percent no-passing sensitivity on travel speed at two-lane highways.

Measures	Low Demand				
	2-Way Volume = 500				
% No-passing Zone	0	10	20	50	80
% Default Change	-100	-50	0	150	300
%Time-spent-following	38.2	43.9	49.6	55.5	58.3
% Change in Results	-23	-11	0	12	18
Average Travel Speed, mph	56.7	55.9	55.1	53.9	53.2
% Change in Results	3	1	0	-2	-3
LOS	B	B	B	C	C
Measures	Average Demand				
	2-Way Volume = 1000				
% No-passing Zone	0	10	20	50	80
% Default Change	-100	-50	0	150	300
%Time-spent-following	61.6	64.5	67.3	70.7	72.4
% Change in Results	-8	-4	0	5	8
Average Travel Speed, mph	52.5	52	51.6	50.9	50.5
% Change in Results	2	1	0	-1	-2
LOS	C	C	D	D	D
Measures	High Demand				
	2-Way Volume = 1600				
% No-passing Zone	0	10	20	50	80
% Default Change	-100	-50	0	150	300
%Time-spent-following	78.3	79.8	81.2	83	83.9
% Change in Results	-4	-2	0	2	3
Average Travel Speed, mph	47.5	47.2	46.9	46.6	46.3
% Change in Results	1	1	0	-1	-1
LOS	D	D	E	E	E

The percent of no-passing zone directly affects the passing opportunity. This parameter has a significant impact on the percent time-spent-following service measure. However, the impact becomes less significant as the traffic demand increases. It has a low effect on the average travel speed (see Table A-42).

PHF directly adjusts the input volume and thus has a noticeable effect on the service measures (see Table A-43). It is interesting to note that the percent time-spent-following is more sensitive to this factor under the low demand conditions and less so under the heavier demand conditions. The opposite trend is observed for the travel speed. The computed speed varies by less than 5% under the low-demand conditions but up to 15% under high-demand conditions.

Percent of trucks and buses has a low degree of sensitivity, with less than 5% impact at all demand levels (see Table A-44).

Table A-43. PHF sensitivity on travel speed at two-lane highways.

Measure	Low Demand				Average Demand				High Demand			
	2-Way Volume = 500				2-Way Volume = 1000				2-Way Volume = 1600			
PHF	0.6	0.88	0.92	1	0.6	0.88	0.92	1	0.6	0.88	0.92	1
% Default Change	-35	-4	0	9	-35	-4	0	9	-35	-4	0	9
%Time-spent-following	59.4	50.9	49.6	47.2	80.0	68.6	67.3	64.8	91.3	82.5	81.2	78.7
% Change in Results	20	3	0	-5	19	2	0	-4	12	2	0	-3
Average Travel Speed, mph	53.2	54.9	55.1	55.4	47.5	51.3	51.6	52.1	39.8	46.4	46.9	48
% Change in Results	-3	0	0	1	-8	-1	0	1	-15	-1	0	2
LOS	C	C	B	B	D	D	D	C	E	E	E	D

Table A-44. %HV sensitivity on travel speed at two-lane highways.

Measure	Low Demand				
	2-Way Volume = 500				
	0	2	14	25	50
% Heavy Vehicles	0	2	14	25	50
% Default Change	-100	0	600	1150	2400
%Time-spent-following	49.5	49.6	49.9	50.3	51
% Change in Results	0	0	1	1	3
Average Travel Speed, mph	55.2	55.1	54.8	55.0	54.8
% Change in Results	0	0	-1	0	-1
LOS	B	B	B	C	C
Measure	Average Demand				
	2-Way Volume = 1000				
	0	2	14	25	50
% Heavy Vehicles	0	2	14	25	50
% Default Change	-100	0	600	1150	2400
%Time-spent-following	67.3	67.3	67.7	68	68.7
% Change in Results	0	0	1	1	2
Average Travel Speed, mph	51.6	51.6	51.4	51.3	50.9
% Change in Results	0	0	0	-1	-1
LOS	D	D	D	D	D
Measure	High Demand				
	2-Way Volume = 1600				
	0	2	14	25	50
% Heavy Vehicles	0	2	14	25	50
% Default Change	-100	0	600	1150	2400
%Time-spent-following	81.2	81.2	82.1	81.2	81.2
% Change in Results	0	0	1	0	0
Average Travel Speed, mph	47.0	46.9	46.8	46.7	46.3
% Change in Results	0	0	0	0	-1
LOS	E	E	E	E	E

Percent of recreational vehicles has no impact on the service measures (see Table A-45).

Length of passing lane (directional method) was analyzed for each of the four optimal ranges specified in the HCM (see Table A-46). The analysis results indicate that this parameter has low impact on percent time-spent-following. It has a moderate impact on travel speed in the first three demand levels but becomes more significant at the very high demand level.

Multilane Highways

Part II of the HCM lists default values for nine input parameters related to multilane highways. Of these nine parameters, length of analysis period does not enter into the Multilane Highways methodology and, therefore, was not included in the sensitivity analyses. Effects of the other eight

Table A-45. %RV sensitivity on travel speed.

Measure	Low Demand				Average Demand				High Demand			
	2-Way Volume = 500				2-Way Volume = 1000				2-Way Volume = 1600			
	0	5	15	25	0	5	15	25	0	5	15	25
%RVs												
% Change from default												
% Time-spent-following	49.6	49.6	49.6	49.6	67.3	67.3	67.3	67.3	81.2	81.2	81.2	81.2
% Change in Results	0%	0%	0%	0%	0%	0%	0%	0%	0%	0%	0%	0%
Average Travel Speed, mph	55.1	55.1	55.1	55.1	51.6	51.6	51.6	51.6	46.9	46.9	46.9	46.9
% Change in Results	0%	0%	0%	0%	0%	0%	0%	0%	0%	0%	0%	0%
LOS	B	B	B	B	D	D	D	D	E	E	E	E

Table A-46. % Passing lane length sensitivity on travel speed.

Measures	Low Demand				Average Demand			
	100/67				200/133			
Passing Ln Length, mi	0.25	0.5	1	1.5	0.5	0.75	1	1.5
% Default Change	-50	0	100	200	-33	0	33	100
%Time-spent-following	22.6	22.4	22.0	21.7	31.7	31.2	30.9	30.3
% Change in Results	1	0	-2	-3	2	0	-1	-3
Average Travel Speed, mph	60.6	60.9	61.7	53.4	58.8	59.3	59.6	51.6
% Change in Results	0	0	1	-12	-1	0	1	-13
LOS	A	A	A	B	A	A	A	B
Measures	High Demand				Very High Demand			
	400/267				1000/667			
Passing Lane Length, mi	0.5	0.75	1	1.5	0.75	1	1.5	2
% Default Change	-33	0	33	100	-25	0%	50	100
%Time-spent-following	53.8	53.0	52.5	51.6	64.2	63.1	60.8	59.3
% Change in Results	2	0%	-1	-3	2%	0	-4%	-6
Average Travel Speed, mph	56.0	56.5	56.9	49.3	48.8	49.2	42.7	37.7
% Change in Results	-1	0	1	-13	-1	0	-13	-23
LOS	C	C	C	C	C	C	D	E

parameters on the service measure (density) were evaluated under low, average, and high traffic demand conditions. Each sensitivity analysis began with a base scenario. Values for the input parameter were varied to record its effects. The input parameters are listed in Table A-47, followed by a summary of the base scenario.

Base Scenario

- PHF = 0.92
- Percent of trucks and buses = 5%
- Percent of recreational vehicles = 2%
- Number of lanes in each direction = 2
- Driver type = commuter
- Terrain = level
- Base free-flow speed, mph = 60
- Lane width, ft = 12.0
- Total lateral clearance, ft = 6.0
- Access point density, points/mi = 16.0
- Median type = divided
- Low demand—subject traffic volume, veh/hr = 1000

Table A-47. Input parameters for multilane highways.

Input Parameter	Default Value	Methodology	HCM Source
Lane width (ft)	12.0	-----	Exh. 12-3
Lateral clearance (ft)	6.0	-----	Exh. 12-3
Access point density (points/mi)	8/16/25	Rural/Low-density/High-density	Exh. 12-4
Specific grade or general terrain	Level	-----	Exh. 12-3
Base free flow speed (mph)	60	-----	Exh. 12-3
Length of analysis period (min)	15	-----	Exh. 12-3
PHF	0.88/0.92	Rural/Urban	Exh. 12-3
Heavy vehicles (%)	10%/5%	Rural/Urban	Exh. 12-3
Driver Population Factor	1.00	-----	Exh. 12-3

- Average demand—subject traffic volume, veh/hr = 2000
- High demand—subject traffic volume, veh/hr = 3400

The default parameters evaluated in this methodology are lane width, lateral clearance, access point density, terrain, base free-flow speed, PHF, %HV, and driver population factor.

Service measure is density and is computed according to the following equation:

$$D = \frac{v_p}{S} \tag{HCM Eq. 21-5}$$

Where

- D = density (pc/mi/ln),
- v_p = flow rate (pc/hr/ln), and
- S = average passenger-car travel speed (mph).

Findings and Recommendations

The lane width input parameter is used to adjust free-flow speed (see Table A-48). The adjustment varies from 0 to 6.9 mph, which translates into a maximum effect of 15% on density. This parameter has a moderate degree of sensitivity.

Lateral clearance is used to adjust free-flow speed. The adjustment varies from 0 to 5.4 mph, which translates into a maximum effect of 9% on density. Lateral clearance has a low degree of sensitivity (see Table A-49).

Access point density is used to adjust free-flow speed. The adjustment varies from 0 to 10 mph, which translates to a moderate level of sensitivity on density. The magnitude of the effect is similar across all three demand levels (see Table A-50).

The analyst can account for the effect of terrain using one of the three predefined terrain types (level, rolling, or mountainous) or using the specific grade or composite grade procedures (see Table A-51). The sensitivity analyses performed focused on the predefined terrain types. The results indicate a low to moderate sensitivity.

Table A-48. Lane width sensitivity on density for multilane highways.

Measures	Low Demand			Average Demand			High Demand		
	Volume = 1000			Volume = 2000			Volume = 3400		
Lane width, ft	10	11	12	10	11	12	10	11	12
% Default Change	-17	-8	0	-17	-8	0	-17	-8	0
Density, pc/mi/ln	11.6	10.6	10.2	23.3	21.2	20.4	42.0	37.8	36.4
% Change in Results	14	4	0	14	4	0	15	4	0
LOS	B	A	A	C	C	C	E	E	E

Table A-49. Lateral clearance sensitivity on density for multilane highways.

Measures	Low Demand			Average Demand			High Demand		
	Volume = 1000			Volume = 2000			Volume = 3400		
Lateral Clearance, ft	0	3	6	0	3	6	0	3	6
% Default Change	-100	-50	0	-100	-50	0	-100	-50	0
Density, pc/mi/ln	11.1	10.5	10.2	22.1	21	20.4	39.7	37.5	36.4
% Change in Results	9	3	0	8	3	0	9	3	0
LOS	B	A	A	C	C	C	E	E	E

Table A-50. Access point sensitivity on density for multilane highways.

Measures	Low Demand				
	Volume = 1000				
Number of Access Points, pts/mi	0	8	16	25	40
% Default Change	-100	-50	0	56	150
Density, pc/mi/ln	9.5	9.9	10.2	10.7	11.5
% Change in Results	-7%	-3	0	5	13
LOS	A	A	A	A	B
Measures	Average Demand				
	Volume = 2000				
Number of Access Points, pts/mi	0	8	16	25	40
% Default Change	-100	-50	0	56	150
Density, pc/mi/ln	19.1	19.7	20.4	21.3	23
% Change in Results	-6	-3	0	4	13
LOS	C	C	C	C	C
Measures	High Demand				
	Volume = 3400				
Number of Access Points, pts/mi	0	8	16	25	40
% Default Change	-100	-50	0	56	150
Density, pc/mi/ln	33.9	35.1	36.4	38.1	41.4
% Change in Results	-7	-4	0	5	14
LOS	D	D	E	E	E

Table A-51. Terrain sensitivity on density for multilane highways.

Measures	Low Demand			Average Demand			High Demand		
	Volume = 1000			Volume = 2000			Volume = 3400		
Terrain (1)	M	R	L	M	R	L	M	R	L
% Default Change									
Density, pc/mi/ln	12.3	10.9	10.2	24.5	21.8	20.4	F	39.3	36.4
% Change in Results	21	7	0	20	7	0	-	8	0
LOS	B	A	A	C	C	C	F	E	E

(1) M = Mountain, R = Rolling, L = Level

Base free-flow speed plays a major role in the estimation of free-flow speed and, subsequently, density (see Table A-52). The current guidance in the HCM suggests the use of the speed limit to estimate base free-flow speed. At low speeds, this input parameter has a significant impact on the resulting density.

PHF directly adjusts the input volume and thus has a noticeable effect on the service measure (see Table A-53). Within the range tested, density increased more than 50% when the PHF was varied by 35%. The effect is more significant under the heavy demand conditions.

%HV displays a low degree of sensitivity on the density service measure (see Table A-54).

Table A-52. Base free-flow speed sensitivity on density for multilane highways.

Measures	Low Demand			Average Demand			High Demand		
	Volume = 1000			Volume = 2000			Volume = 3400		
Base FFS, mi/h	45	55	60	45	55	60	45	55	60
% Default Change	-25	-8	0	-25	-8	0	-25	-8	0
Density, pc/mi/ln	14.1	11.3	10.2	28.2	22.5	20.4	F	40.5	36.4
% Change in Results	38	11	0	38	10	0		11	0
LOS	B	B	A	D	C	C	F	E	E

Table A-53. PHF sensitivity on density for multilane highways.

Measures	Low Demand				Average Demand				High Demand			
	Volume = 1000				Volume = 2000				Volume = 3400			
PHF	0.6	0.8	0.92	1	0.6	0.8	0.92	1	0.6	0.8	0.92	1
% Default Change	-35	-13	0	9	-35	-13	0	9	-35	-13	0	9
Density, pc/mi/ln	15.7	11.8	10.2	9.4	32.1	23.5	20.4	18.8	F	43.5	36.4	32.9
% Change in Results	54	16	0	-8	57	15	0	-8		20	0	-10
LOS	B	B	A	A	D	C	C	C	F	E	E	D

Table A-54. %HV sensitivity on density for multilane highways.

Measures	Low Demand				Average Demand				High Demand			
	Volume = 1000				Volume = 2000				Volume = 3400			
%Heavy Vehicles	0	5	15	25	0	5	15	25	0	5	15	25
% Default Change	-100	0	200	400	-100	0	200	400	-100	0	200	400
Density, pc/mi/ln	10	10.2	10.7	11.2	20	20.4	21.4	22.4	35.3	36.4	38.6	40.9
% Change in Results	-2	0	5	10	-2	0	5	10	-3	0	6	12
LOS	A	A	A	B	C	C	C	C	E	E	E	E

Driver population factor is a flow rate adjustment factor. The sensitivity analyses show that density is moderately sensitive to the variation of driver population (see Table A-55). Despite this finding, the current default values are adopted from research efforts in Florida. It may be appropriate to consider other local data sources.

Basic Freeway Segments

Part II of HCM 2000 lists default values for eight input parameters related to a basic freeway segment. Of these eight input parameters, the length of analysis period does not enter into the methodology and therefore was not included in the sensitivity analyses. Effects of the other seven input parameters on the performance measure (density) were evaluated under low, average, and high traffic congestion conditions. Each sensitivity analysis began with a base scenario. Values for the input parameter were varied to record its effects. The input parameters are listed in Table A-56, followed by a summary of the base scenario.

Base Scenario

- PHF = 0.92
- Percent of trucks and buses = 5%
- Percent of recreational vehicles = 2%
- Number of lanes in each direction = 3
- Driver type = commuter
- Terrain = level

Table A-55. Driver population sensitivity on density for multilane highways.

Measures	Low Demand				Average Demand				High Demand			
	Volume = 1000				Volume = 2000				Volume = 3400			
Driver Population Factor	0.85	0.90	0.95	1.00	0.85	0.90	0.95	1.00	0.85	0.90	0.95	1.00
% Default Change	-15	-10	-5	0	-15	-10	-5	0	-15	-10	-5	0
Density, pc/mi/ln	12	11.4	10.8	10.2	24.1	22.7	21.5	20.4	F	41.6	38.8	36.4
% Change in Results	18	12	6	0	18	11	5	0		14	7	0
LOS	B	B	A	A	C	C	C	C	F	F	E	E

Table A-56. Summary of basic freeway segment input parameters.

Input Parameter	Default Value	Methodology	HCM Source
Lane width (ft)	12.0	Basic freeway segments	Exh. 13-5
Lateral clearance (ft)	10.0	Basic freeway segments	Exh. 13-5
Specific grade or general terrain	Level	Basic freeway segments	Exh. 13-5
Base free-flow speed (mph)	75/70	Basic freeway segments	Exh. 13-5
Length of analysis period (min)	15	Basic freeway segments	Exh. 13-5
PHF	0.88/0.92	Basic freeway segments	Exh. 13-5
%HV	10%/5%	Basic freeway segments	Exh. 13-5
Driver population factor	1.00	Basic freeway segments	Exh. 13-5

- Base free-flow speed, mph = 70
- Lane width, ft = 12.0
- Right-shoulder lateral clearance, ft = 6.0
- Interchange density, interchanges/mi = 0.5
- Low demand—subject traffic volume, veh/hr = 3,300
- Average demand—subject traffic volume, veh/hr = 4,950
- High demand—subject traffic volume, veh/hr = 5,940

The input parameters evaluated in this methodology are lane width, lateral clearance, terrain, base free-flow speed, PHF, %HV, and driver population factor.

The service measure is density. It is computed according to the following equation:

$$D = \frac{v_p}{S} \quad (\text{HCM Eq. 23-4})$$

Where

- D = density (pc/mi/ln),
- v_p = flow rate (pc/hr/ln), and
- S = average passenger-car travel speed (mph).

Findings and Recommendations

The input parameter, lane width, is used to adjust free-flow speed in this method (see Table A-57). The adjustment varies from 0 to 6.6 mph, which translates into a maximum effect of 11% on density. Lane width has a low to moderate degree of sensitivity.

Lateral clearance is used to adjust free-flow speed in this method (see Table A-58). The adjustment varies from 0 to 3.6 mi/h, which translates into a maximum effect of 3% on density. Lateral clearance has a low degree of sensitivity.

In this methodology, the analyst can account for the effect of terrain using one of the three pre-defined terrain types (level, rolling, or mountainous) or using the specific grade or composite grade

Table A-57. Lane width sensitivity on density for freeway segments.

Measures	Low Congestion			Average Congestion			High Congestion		
	(v/c=0.5) 3300			(v/c=0.75) 4950			(v/c=0.9) 5940		
Urban Conditions									
Lane width, ft	10	11	12	10	11	12	10	11	12
% Default Change	-17	-8	0	-17	-8	0	-17	-8	0
Density, pc/mi/ln	20.4	18.9	18.4	30.9	29	28.4	41.1	39.1	38.3
% Change in Results	11	3	0	9	2	0	7	2	0
LOS	C	C	C	E	E	D	F	E	E

Table A-58. Lateral clearance sensitivity on density for freeway segments.

Measures	Low Congestion			Average Congestion			High Congestion		
	(v/c=0.5) 3300			(v/c=0.75) 4950			(v/c=0.9) 5940		
Lateral Clearance, ft	0	3	6	0	3	6	0	3	6
% Default Change	-100	-50	0	-100	-50	0	-100	-50	0
Density, pc/mi/ln	19	18.7	18.4	29.2	28.8	28.4	39.3	38.8	38.3
% Change in Results	3	2	0	3	1	0	3	1	0
LOS	C	C	C	E	E	D	E	E	E

procedures (see Table A-59). The sensitivity analyses performed focused on the predefined terrain types. The results indicate that the density has a significant degree of sensitivity to the terrain type.

According to the HCM, base free-flow speed plays a major role in the estimation of free-flow speed and, subsequently, density. Despite this, the analyses indicate a low degree of sensitivity (see Table A-60).

PHF directly adjusts the input volume and thus has a noticeable effect on the service measure (see Table A-61). Within the range tested, density increased more than 50% when the PHF was varied by 35%. The effect is slightly more significant under the heavy congestion conditions.

%HV displays a low to moderate degree of sensitivity (see Table A-62).

Driver population factor is a flow rate adjustment factor (see Table A-63). The density is moderately sensitive to the variation of driver population factor under low traffic congestion conditions and highly sensitive under heavy traffic conditions.

Ramps and Ramp Junctions

There are two distinct methods in this chapter: one for the analysis of a merge influence area and the other for the analysis of a diverge influence area. Part II of the HCM lists default values for six input parameters related to ramp merge/diverge areas. Except for the acceleration and deceleration lengths, the other four parameters are inputs to both methods. Although it is an input

Table A-59. Terrain sensitivity on density at freeway segments.

Measure	Low Congestion			Average Congestion			High Congestion		
	(v/c=0.5) 3300			(v/c=0.75) 4950			(v/c=0.9) 5940		
Terrain (1)	M	R	L	M	R	L	M	R	L
% Default Change									
Density, pc/mi/ln	22.0	19.5	18.4	38.3	31	28.4	>45	44.3	38.3
% Change in Results	20	6	0	35	9	0	-	16	0
LOS	C	C	C	F	E	D	F	E	E

(1) M = Mountain, R = Rolling, L = Level

Table A-60. Base free-flow speed sensitivity on density at freeway segments.

Measures	Low Congestion			Average Congestion			High Congestion		
	(v/c=0.5) 3300			(v/c=0.75) 4950			(v/c=0.9) 5940		
Base FFS, mph	70	73	75	70	73	75	70	73	75
% Default Change	0	4	7	0	4	7	0	4	7
Density, pc/mi/ln	18.4	17.6	16.4	28.4	27.4	26.3	38.3	37.1	36.5
% Change in Results	0	-4	-11	0	-4	-7	0	-3	-5
LOS	C	C	B	D	D	D	E	E	E

Table A-61. PHF sensitivity on density for freeway segments.

Measures	Low Congestion				Average Congestion)				High Congestion			
	(v/c=0.5) 3300				(v/c=0.75) 4950				(v/c=0.9) 5940			
PHF	0.6	0.8	0.92	1	0.6	0.8	0.92	1	0.6	0.8	0.92	1
% Default Change	-35	-13	0	9	-35	-13	0	9	-35	-13	0	9
Density, pc/mi/ln	29.2	21.1	18.4	16.9	>45	35.2	28.4	25.6	>45	>45	38.3	32.8
% Change in Results	59	15	0	-8		24	0	-10			0	-14
LOS	D	C	C	B	F	E	D	D	F	F	E	D

Table A-62. %HV sensitivity on density for freeway segments.

Measures	Low Congestion				Average Congestion				High Congestion			
	(v/c=0.5) 3300				(v/c=0.75) 4950				(v/c=0.9) 5940			
%HV	0	5	15	25	0	5	15	25	0	5	15	25
% Default Change	-100	0	200	400	-100	0	200	400	-100	0	200	400
Density, pc/mi/ln	17.9	18.4	19.3	20.1	27.5	28.4	30.3	32.5	36.4	38.3	42.7	<45
% Change in Results	-3	0	5	9	-3	0	7	14	-5	0	11	
LOS	B	C	C	C	D	D	D	D	E	E	E	F

Table A-63. Driver population sensitivity on density for freeway segments.

Measures	Low Congestion				Average Congestion				High Congestion			
	(v/c=0.5) 3300				(v/c=0.75) 4950				(v/c=0.9) 5940			
Driver Population	0.85	0.9	0.95	1	0.85	0.9	0.95	1	0.85	0.9	0.95	1
% Default Change	-15	-10	-5	0	-15	-10	-5	0	-15	-10	-5	0
Density, pc/mi/ln	21.6	20.4	19.3	18.4	36.8	33.1	30.5	28.4	>45	>45	43.1	39.3
% Change in Results	17	11	5	0	30	17	7	0			10	0
LOS	C	C	C	C	E	D	D	D	F	F	E	E

to the diverge junction method, the ramp free-flow speed only affects the calculation of ramp junction speed. It does not affect the calculation of density, the service measure. For this reason, it was not included in the sensitivity analyses for the diverge junction. As with other methodologies, the effects of the input parameters on the service measure (density) were evaluated under low, average, and high traffic congestion conditions. Each sensitivity analysis began with a base scenario. Values for the input parameter were varied to record its effects. The input parameters are listed in Table A-64, followed by a summary of the base scenarios.

Base Scenario

Merge Junction Methodology

- Right-side ramp with 3 mainline lanes and 1 ramp on-ramp lane
- PHF = 0.92 (for both mainline and ramp)

Table A-64. Summary of input parameters for ramps and ramp junctions.

Input Parameter	Default Value	Methodology	HCM Source
Acceleration lane length (ft)	590	Merge area	Exh. 13-17
Deceleration lane length (ft)	140	Diverge area	Exh. 13-17
Free-flow speed (mph)	35	Merge area	Exh. 13-17
PHF	0.88/0.92	Merge area/Diverge area	Exh. 13-17
%HV	10%/5%	Merge area/Diverge area	Exh. 13-17
Driver population factor	1.00	Merge area/Diverge area	Exh. 13-17

112 Default Values for Highway Capacity and Level of Service Analyses

- %HV = 5% (for both mainline and ramp)
- Mainline free-flow speed, mph = 70.0
- Ramp free-flow speed, mph = 35
- Driver type = commuter
- Terrain = level
- Acceleration lane length, ft = 590
- No upstream or downstream ramp
- Low demand—traffic volume, veh/hr = 3000 (mainline); 300 (ramp)
- Average demand—traffic volume, veh/hr = 4350 (mainline); 600 (ramp)
- High demand—traffic volume, veh/hr = 5040 (mainline); 900 (ramp)

The input parameters evaluated in this methodology are acceleration length, ramp free-flow speed, PHF, %HV, and driver population factor.

The service measure is density. It is computed according to the following equation:

$$D_R = 5.475 + 0.00734v_R + 0.0078v_{12} - 0.00627L_A \quad (\text{HCM Eq. 25-5})$$

Where

D_R = density of merge influence area (pc/mi/ln),
 v_R = on-ramp peak 15-min flow rate (pc/hr),
 v_{12} = flow rate entering ramp influence area (pc/hr), and
 L_A = length of acceleration lane (ft).

Diverge Junction Methodology

- Right-side ramp with 3 mainline lanes and 1 ramp off-ramp lane
- PHF = 0.92 (for both mainline and ramp)
- %HV = 5% (for both mainline and ramp)
- Mainline free-flow speed, mph = 70.0
- Ramp free-flow speed, mph = 35
- Driver type = commuter
- Terrain = level
- Deceleration lane length, ft = 140
- No upstream or downstream ramp
- Low demand—traffic volume, veh/hr = 3000 (mainline); 300 (ramp)
- Average demand—traffic volume, veh/hr = 4350 (mainline); 600 (ramp)
- High demand—traffic volume, veh/hr = 5040 (mainline); 900 (ramp)

The default parameters evaluated in this methodology are deceleration length, PHF, %HV, and driver population factor.

The service measure is density. It is computed according to the following equation.

$$D_R = 4.252 + 0.0086v_{12} - 0.009L_D \quad (\text{HCM Eq. 25-10})$$

Where

D_R = density of diverge influence area (pc/mi/ln),
 v_{12} = flow rate entering ramp influence area (pc/hr), and
 L_D = length of deceleration lane (ft).

Findings and Recommendations

Acceleration lane length at a merge is used in calculations of both flow rate in the influence area and density. Its impact is significant only when the lane length is more than double the existing default value (see Table A-65).

Table A-65. Acceleration lane length sensitivity on density for ramp merges.

Measures	Low Demand						
	Mainline = 3000; Ramp = 300						
Acceleration lane length, ft	410	470	590	710	770	1000	2000
% Default Change	-31	-20	0	20	31	69	239
Density, pc/mi/ln	20.7	20.4	19.7	19.1	18.7	17.4	11.9
LOS	C	C	B	B	B	B	B
% Change in Results	5	4	0	-3	-5	-12	-40
Measures	Average Demand						
	Mainline = 4350; Ramp = 600						
Acceleration lane length, ft	410	470	590	710	770	1000	2000
% Default Change	-31	-20	0	20	31	69	239
Density, pc/mi/ln	30.1	29.8	29.1	28.5	28.2	27.0	21.8
LOS	D	D	D	D	D	C	C
% Change in Results	3	2	0	-2	-3	-7	-25
Measures	High Demand						
	Mainline = 5040; Ramp = 900						
Acceleration lane length, ft	410	470	590	710	770	1000	2000
% Default Change	-31	-20	0	20	31	69	239
Density, pc/mi/ln	36.1	35.8	35.2	34.5	34.2	33.1	28.0
LOS	E	E	E	D	D	D	C
% Change in Results	3	2	0	-2	-3	-6	-20

Deceleration lane length at the ramp diverge has even less impact on the service measure than the acceleration lane (see Table A-66). A closer examination of the methodology indicates that it is only used in the estimation of density, not flow rate.

Ramp free-flow speed at a merge has no impact on density (see Table A-67). Closer examination of the methodology indicates that it only affects the calculation of flow rate for an 8-lane freeway.

Table A-66. Deceleration lane length sensitivity on density for ramp diverges.

Measures	Low Demand						
	Mainline = 3000; Ramp = 300						
Deceleration lane length, ft	90	110	140	170	190	1000	2000
% Default Change	-36	-21	0	21	36	614	1329
Density, pc/mi/ln	23.4	23.2	23.0	22.7	22.5	15.2	6.2
LOS	C	C	C	C	C	B	A
% Change in Results	2	1	0	-1	-2	-34	-73
Measures	Average Demand						
	Mainline = 4350; Ramp = 600						
Deceleration lane length, ft	90	110	140	170	190	1000	2000
% Default Change	-36	-21	0	21	36	614	1329
Density, pc/mi/ln	31.0	30.9	30.6	30.3	30.1	22.8	13.8
LOS	D	D	D	D	D	C	B
% Change in Results	1	1	0	-1	-2	-25%	-55%
Measures	High Demand						
	Mainline = 5040; Ramp = 900						
Deceleration lane length, ft	90	110	140	170	190	1000	2000
% Default Change	-36	-21	0	21	36	614	1329
Density, pc/mi/ln	34.8	34.6	34.4	34.1	33.9	26.6	17.6
LOS	D	D	D	D	D	C	B
% Change in Results	1	1	0	-1	-1	-23	-49

Table A-67. Free-flow speed sensitivity on density for ramp merges.

Measures	Low Demand				
	Mainline = 3000; Ramp = 300				
	20	30	35	40	50
Ramp FFS, mi/h	20	30	35	40	50
% Default Change	-43	-14	0	14	43
Density, pc/mi/ln	20	20	20	20	20
LOS	B	B	B	B	B
% Change in Results	0	0	0	0	0
Measures	Average Demand				
	Mainline = 4350; Ramp = 600				
	20	30	35	40	50
Ramp FFS, mi/h	20	30	35	40	50
% Default Change	-43	-14	0	14	43
Density, pc/mi/ln	29.1	29.1	29.1	29.1	29.1
LOS	D	D	D	D	D
% Change in Results	0	0	0	0	0
Measures	High Demand				
	Mainline = 5040; Ramp = 900				
	20	30	35	40	50
Ramp FFS, mi/h	20	30	35	40	50
% Default Change	-43	-14	0	14	43
Density, pc/mi/ln	35.2	35.2	35.2	35.2	35.2
LOS	E	E	E	E	E
% Change in Results	0	0	0	0	0

Ramp PHF (merge and diverge methods) has less than 10% impact on the service measure (see Table A-68). This is because the flow rate (which is influenced by the PHF) is only one of the variables that influence the service measure (density). At all three demand levels evaluated, the impact was less significant for the diverge junction than for the merge junction.

In evaluating the effect of heavy vehicles, the %HV on the ramp was varied while the %HV on the mainline remained the same. (The effect of heavy vehicles on the mainline was evaluated in Basic Freeway Segments subsection.) The analysis results indicate a low degree of sensitivity in both the merge and the diverge methodologies (see Table A-69). This is because the flow rate (which is influenced by the %HV) is only one of the variables that influence the service measure (density).

Table A-68. PHF sensitivity on density for ramp merge and diverge.

Merge Measures	Low Demand				Average Demand				High Demand			
	Mainline = 3000 Ramp = 300				Mainline = 4350 Ramp = 600				Mainline = 5040 Ramp = 900			
	0.6	0.8	0.92	1	0.6	0.8	0.92	1	0.6	0.8	0.92	1
Ramp PHF	0.6	0.8	0.92	1	0.6	0.8	0.92	1	0.6	0.8	0.92	1
% Default Change	-35	-13	0	9	-35	-13	0	9	-35	-13	0	9
Density, pc/mi/ln	21.0	20.1	19.7	19.5	31.8	29.9	29.1	28.7	F	36.3	35.2	34.6
LOS	C	C	B	B	D	D	D	D	F	E	E	D
% Change in Results	7	2	0	-1	9	3	0	-1		3	0	-2
Diverge Measures	Low Demand				Average Demand				High Demand			
	Mainline = 3000; Ramp = 300				Mainline = 4350 Ramp = 600				Mainline = 5040 Ramp = 900			
	0.6	0.8	0.92	1	0.6	0.8	0.92	1	0.6	0.8	0.92	1
Ramp PHF	0.6	0.8	0.92	1	0.6	0.8	0.92	1	0.6	0.8	0.92	1
% Default Change	-35	-13	0	9	-35	-13	0	9	-35	-13	0	9
Density, pc/mi/ln	23.3	23.1	23.0	22.9	31.3	30.8	30.6	30.5	35.5	34.7	34.4	34.2
LOS	C	C	C	C	D	D	D	D	E	D	D	D
% Change in Results	1	0	0	0	2	1	0	0	3	1	0	-1

Table A-69. % HV sensitivity for density at ramps.

Merge Measures	Low Demand				Average Demand				High Demand			
	Mainline = 3000 Ramp = 300				Mainline = 4350 Ramp = 600				Mainline = 5040 Ramp = 900			
Ramp %HV	0	5	15	25	0	5	15	25	0	5	15	25
% Default Change	-100	0	200	400	-100	0	200	400	-100	0	200	400
Density, pc/mi/ln	19.7	19.7	19.8	20.0	29.0	29.1	29.4	29.6	35.0	35.2	35.5	35.9
LOS	B	B	B	B	D	D	D	D	D	E	E	E
% Change in Results	0	0	1	2	0	0	1	2	-1	0	1	2

Diverge Measures	Low Demand				Average Demand				High Demand			
	Mainline = 3000 Ramp = 300				Mainline = 4350 Ramp = 600				Mainline = 5040 Ramp = 900			
Ramp %HV	0	5	15	25	0	5	15	25	0	5	15	25
% Default Change	-100	0	200	400	-100	0	200	400	-100	0	200	400
Density, pc/mi/ln	23.0	23.0	23.0	23.0	30.6	30.6	30.6	30.6	34.3	34.4	34.5	34.5
LOS	C	C	C	C	D	D	D	D	D	D	D	D
% Change in Results	0	0	0	0	0	0	0	0	0	0	0	0

Driver population factor was assumed to be the same on the mainline and the ramp. Therefore, this input parameter was varied for both the mainline and the ramp at the same time. For example, a factor of 0.85 was applied to both the mainline and the ramp. The sensitivity results indicated a moderate degree of sensitivity (see Table A-70).

Conclusion

There are 63 input parameters in eight chapters of HCM 2000 for which default values are suggested. Seven of these input parameters are not used in the HCM methodologies. To determine where default values for these input parameters would be most significant, a sensitivity analysis was conducted by applying a set of low, average, and high demands to each of these methodologies. As a result of these, the default values were judged to have a low, moderate, or significant degree of sensitivity in influencing the results. Table A-71 summarizes the sensitivity determined for each of these input parameters.

Table A-70. Driver population sensitivity on density for ramps.

Merge Measures	Low Demand				Average Demand				High Demand			
	Mainline = 3000 Ramp = 300				Mainline = 4350 Ramp = 600				Mainline = 5040 Ramp = 900			
Driver Population Factor	0.85	0.9	0.95	1	0.85	0.9	0.95	1	0.85	0.9	0.95	1
% Default Change	-15	-10	-5	0	-15	-10	-5	0	-15	-10	-5	0
Density, pc/mi/ln	22.9	21.7	20.7	19.7	34.0	32.2	30.6	29.1	F	F	36.9	35.2
LOS	C	C	C	B	D	D	D	D	F	F	E	E
% Change in Results	16	10	5	0	17	11	5	0			5	0

Diverge Measures	Low Demand				Average Demand				High Demand			
	Mainline = 3000 Ramp = 300				Mainline = 4350 Ramp = 600				Mainline = 5040 Ramp = 900			
Driver Population Factor	0.85	0.9	0.95	1	0.85	0.9	0.95	1	0.85	0.9	0.95	1
% Default Change	-15	-10	-5	0	-15	-10	-5	0	-15	-10	-5	0
Density, pc/mi/ln	26.0	24.9	23.9	23.0	34.3	33.0	31.7	30.6	38.4	36.9	35.6	34.4
LOS	C	C	C	C	D	D	D	D	E	E	E	D
% Change in Results	13	8	4	0	12	8	4	0	12	7	3	0

Table A-71. Summary of sensitivity of default parameters on service measures.

Input Parameter	Degree of Sensitivity
General Traffic Characteristics	
PHF	Evaluated with individual chapters
K	Not evaluated
D	Not evaluated
Urban Streets	
Signal density (signals/mi)	Significant
Free-flow speed (mph)	Low
Signalized Intersections	
Exclusive turn lane required	Used for geometric design, not for operational analysis
PHF	Significant
Length of analysis period (hr)	Significant
Arrival Type (AT)	Significant
Adjusted Sat flow (veh/hr/ln)	Significant when traffic demand approaches oversaturation
Base sat flow (pc/hr/ln)	Significant when traffic demand approaches oversaturation
Lane widths (ft)	Significant when traffic demand approaches oversaturation
%HV	Significant
Lane utilization (f_{LU})	Significant
Cycle length (sec)	Moderate
Lost time (sec/cycle)	Moderate
Parking maneuvers	Moderate
Unit extension time (sec)	Low
Actuated control adjustment factor (k)	Low
Upstream filtering adjustment factor (l)	Low to moderate
Grades	Low to moderate
Local bus frequency (buses stopping/hr)	Low
Pedestrians (peds/hr)	Low
Pedestrians	
Effective sidewalk width (ft)	Significant
Street corner radius (ft)	Significant
Pedestrian walking speed (ft/s)	Significant
Pedestrian start-up time (s)	Significant
Bicycles Paths	
PHF	Significant
Bicycle speed (mph)	Significant
Bicycle path width (ft)	Not used in method
Multilane Highways	
Specific grade or general terrain	Low to Moderate
Base free flow speed (mph)	Significant
PHF	Significant
Lane width (ft)	Moderate
Access point density (points/mi)	Moderate
Driver population factor	Moderate
%HV	Low
Lateral clearance (ft)	Low
Length of analysis period (min)	Not used in method
Two-Lane Highways	
Length of passing lanes (mi)	Low (% time spent-following) Moderate—Significant (travel speed)
Percent no-passing	Low to moderate
PHF	Moderate
Lane width (ft)	Low impact on speed; no impact on percent time-spent-following (PTSF)
Shoulder width (ft)	Low impact on speed; no impact on PTSF
Access point density (points/mi)	Low impact on speed; no impact on PTSF
Specific grade or general terrain	Low
%HV (trucks/buses)	Low
%HV (RVs)	No impact
Length of analysis period (min)	Not used in method
Directional split	Not used in method

Table A-71. (Continued).

Input Parameter	Degree of Sensitivity
Basic Freeway Segments	
Driver population factor	Moderate to significant
Specific grade or general terrain	Significant
PHF	Significant
%HV	Low to moderate
Lane width (ft)	Low to moderate
Lateral clearance (ft)	Low
Base free-flow speed (mph)	Low
Length of analysis period (min)	Not used in method
Ramps and Ramp Junctions	
Driver population factor	Moderate for merge and diverge methodologies
Acceleration lane length (ft)	Low for merge methodology
Deceleration lane length (ft)	Low for diverge methodology
Free-flow speed (mph)	Not used in method
PHF	Low for merge and diverge methodologies
%HV	Low for merge and diverge methodologies



APPENDIX B

Lane Utilization Adjustment Factors for Interchange Ramp Terminals

Table B-1. Lane utilization adjustment factors by turning movement distribution for external approaches to diamond interchanges.

O-D Demand Movement Distribution			Lane Utilization Adjustment Factor, f_{LU}	
v_E, v_H	v_I, v_J	v_F, v_G	3-Lane Approach	4-Lane Approach
10%	20%	70%	0.458	0.371
20%	20%	60%	0.526	0.426
30%	20%	50%	0.617	0.500
40%	20%	40%	0.746	0.606
50%	20%	30%	0.677	0.506
60%	20%	20%	0.592	0.420
70%	20%	10%	0.525	0.359
10%	30%	60%	0.500	0.409
20%	30%	50%	0.582	0.478
30%	30%	40%	0.696	0.573
40%	30%	30%	0.748	0.588
50%	30%	20%	0.645	0.475
60%	30%	10%	0.567	0.398
10%	40%	50%	0.551	0.457
20%	40%	40%	0.651	0.544
30%	40%	30%	0.797	0.672
40%	40%	20%	0.709	0.546
50%	40%	10%	0.616	0.447

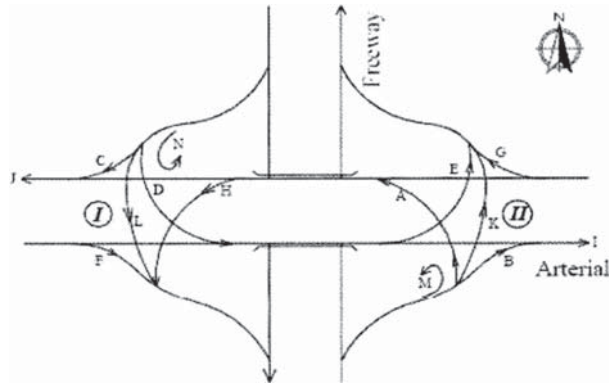

Figure B-1. Illustration of origin-destination demands through a diamond interchange.

Table B-2. Lane utilization adjustment factors by turning movement distribution for external approaches to PARCLO A-2Q interchanges.

O-D Demand Movement Distribution		Lane Utilization Factor, f_{LU}		
v_E, v_H	v_I, v_J	2-Lane Approach	3-Lane Approach	4-Lane Approach
10%	90%	0.905	0.836	0.770
20%	80%	0.826	0.718	0.626
30%	70%	0.760	0.629	0.527
40%	60%	0.703	0.560	0.456
50%	50%	0.655	0.504	0.401
60%	40%	0.613	0.459	0.358
70%	30%	0.575	0.421	0.323
80%	20%	0.543	0.389	0.295

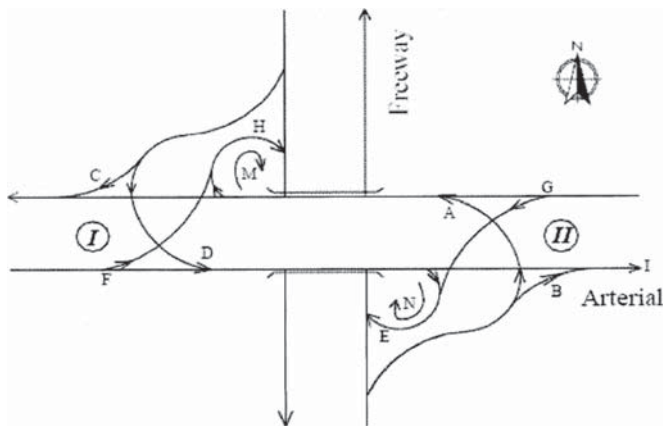

Figure B-2. Illustration of origin-destination demands through a PARCLO A-2Q.

Table B-3. Lane utilization adjustment factors by turning movement distribution for external approaches to PARCLO B-2Q interchanges.

O-D Demand Movement Distribution			Lane Utilization Adjustment Factor, f_{LU}		
v_E, v_H	v_I, v_J	v_F, v_G	2-Lane Approach	3-Lane Approach	4-Lane Approach
10%	20%	70%	0.712	0.429	0.325
20%	20%	60%	0.795	0.502	0.382
30%	20%	50%	0.899	0.604	0.464
40%	20%	40%	0.967	0.710	0.536
70%	20%	10%	0.679	0.474	0.362
60%	20%	20%	0.754	0.533	0.406
50%	20%	30%	0.847	0.609	0.462
40%	20%	40%	0.967	0.710	0.536
10%	30%	60%	0.749	0.471	0.362
20%	30%	50%	0.841	0.560	0.435
30%	30%	40%	0.959	0.691	0.544
40%	30%	30%	0.906	0.678	0.525
60%	30%	10%	0.717	0.515	0.400
50%	30%	20%	0.800	0.586	0.454
40%	30%	30%	0.906	0.678	0.525
30%	30%	40%	0.959	0.691	0.544
10%	40%	50%	0.790	0.523	0.409
20%	40%	40%	0.893	0.634	0.504
30%	40%	30%	0.975	0.765	0.607
40%	40%	20%	0.853	0.649	0.514
50%	40%	10%	0.759	0.564	0.445
40%	40%	20%	0.853	0.649	0.514
30%	40%	30%	0.975	0.765	0.607
20%	40%	40%	0.893	0.634	0.504

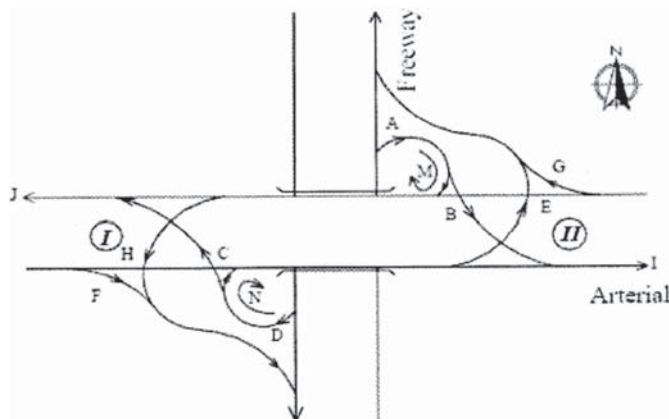

Figure B-3. Illustration of origin-destination demands through a PARCLO B-2Q interchange.

Table B-4. Lane utilization adjustment factors by turning movement distribution for external approaches to PARCLO AB-4Q interchanges.

WESTBOUND						EASTBOUND					
O-D Demand Movement Distribution			Lane Utilization Adjustment Factor, f_{LU}			O-D Demand Movement Distribution			Lane Utilization Adjustment Factor, f_{LU}		
v_H	v_J	v_G	2-Lane Approach	3-Lane Approach	4-Lane Approach	v_E	v_I	v_F	2-Lane Approach	3-Lane Approach	4-Lane Approach
10%	20%	70%	0.712	0.429	0.325	10%	20%	70%	0.656	0.427	0.310
20%	20%	60%	0.795	0.502	0.382	20%	20%	60%	0.641	0.435	0.313
30%	20%	50%	0.899	0.604	0.464	30%	20%	50%	0.626	0.444	0.315
40%	20%	40%	0.967	0.710	0.536	40%	20%	40%	0.613	0.453	0.317
70%	20%	10%	0.679	0.474	0.362	70%	20%	10%	0.575	0.483	0.325
60%	20%	20%	0.754	0.533	0.406	60%	20%	20%	0.587	0.472	0.322
50%	20%	30%	0.847	0.609	0.462	50%	20%	30%	0.600	0.462	0.320
40%	20%	40%	0.967	0.710	0.536	40%	20%	40%	0.613	0.453	0.317
10%	30%	60%	0.749	0.471	0.362	10%	30%	60%	0.683	0.461	0.340
20%	30%	50%	0.841	0.560	0.435	20%	30%	50%	0.667	0.471	0.343
30%	30%	40%	0.959	0.691	0.544	30%	30%	40%	0.651	0.481	0.346
40%	30%	30%	0.906	0.678	0.525	40%	30%	30%	0.637	0.491	0.349
60%	30%	10%	0.717	0.515	0.400	60%	30%	10%	0.609	0.514	0.355
50%	30%	20%	0.800	0.586	0.454	50%	30%	20%	0.623	0.503	0.352
40%	30%	30%	0.906	0.678	0.525	40%	30%	30%	0.637	0.491	0.349
30%	30%	40%	0.959	0.691	0.544	30%	30%	40%	0.651	0.481	0.346
10%	40%	50%	0.790	0.523	0.409	10%	40%	50%	0.713	0.501	0.376
20%	40%	40%	0.893	0.634	0.504	20%	40%	40%	0.695	0.512	0.379
30%	40%	30%	0.975	0.765	0.607	30%	40%	30%	0.678	0.525	0.383
40%	40%	20%	0.853	0.649	0.514	40%	40%	20%	0.662	0.537	0.386
50%	40%	10%	0.759	0.564	0.445	50%	40%	10%	0.647	0.551	0.390
40%	40%	20%	0.853	0.649	0.514	40%	40%	20%	0.662	0.537	0.386
30%	40%	30%	0.975	0.765	0.607	30%	40%	30%	0.678	0.525	0.383
20%	40%	40%	0.893	0.634	0.504	20%	40%	40%	0.695	0.512	0.379

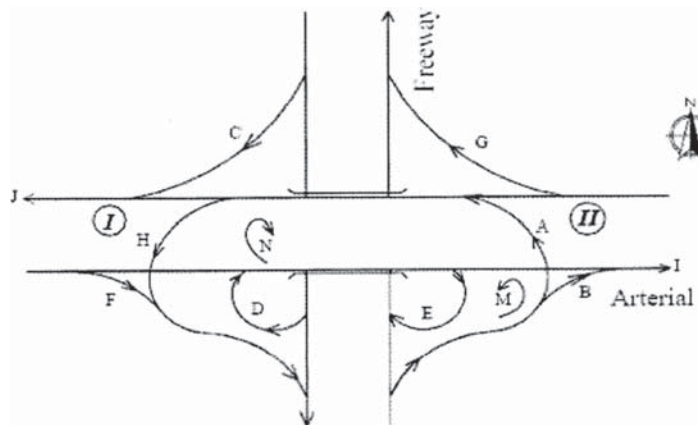

Figure B-4. Illustration of origin-destination demands through a PARCLO AB-4Q interchange.

Table B-5. Lane utilization adjustment factors by turning movement distribution for external approaches to PARCLO A-4Q interchanges.

O-D Demand Movement Distribution			Lane Utilization Adjustment Factor, f_{LU}		
V_E, V_H	V_I, V_J	V_F, V_G	2-Lane Approach	3-Lane Approach	4-Lane Approach
10%	20%	70%	0.656	0.427	0.310
20%	20%	60%	0.641	0.435	0.313
30%	20%	50%	0.626	0.444	0.315
40%	20%	40%	0.613	0.453	0.317
70%	20%	10%	0.575	0.483	0.325
60%	20%	20%	0.587	0.472	0.322
50%	20%	30%	0.600	0.462	0.320
40%	20%	40%	0.613	0.453	0.317
10%	30%	60%	0.683	0.461	0.340
20%	30%	50%	0.667	0.471	0.343
30%	30%	40%	0.651	0.481	0.346
40%	30%	30%	0.637	0.491	0.349
60%	30%	10%	0.609	0.514	0.355
50%	30%	20%	0.623	0.503	0.352
40%	30%	30%	0.637	0.491	0.349
30%	30%	40%	0.651	0.481	0.346
10%	40%	50%	0.713	0.501	0.376
20%	40%	40%	0.695	0.512	0.379
30%	40%	30%	0.678	0.525	0.383
40%	40%	20%	0.662	0.537	0.386
50%	40%	10%	0.647	0.551	0.390
40%	40%	20%	0.662	0.537	0.386
30%	40%	30%	0.678	0.525	0.383
20%	40%	40%	0.695	0.512	0.379

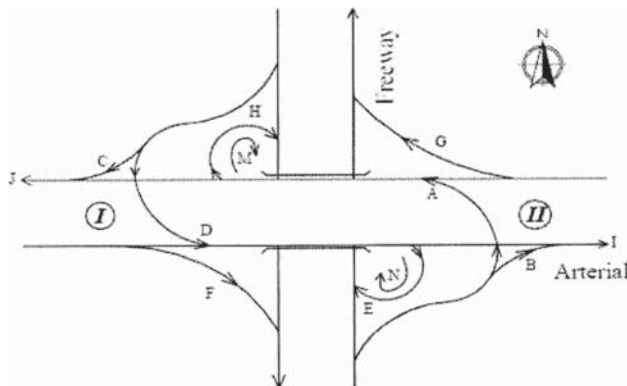

Figure B-5. Illustration of origin-destination demands through a PARCLO A-4Q interchange.

Table B-6. Lane utilization adjustment factors by turning movement distribution for external approaches to PARCLO AB-2Q interchanges.

EASTBOUND						WESTBOUND				
O-D Demand Movement Distribution			Lane Utilization Adjustment Factor, f_{LU}			O-D Demand Movement Distribution		Lane Utilization Adjustment Factor, f_{LU}		
v_E	v_I	v_F	2-Lane Approach	3-Lane Approach	4-Lane Approach	v_H	v_J	2-Lane Approach	3-Lane Approach	4-Lane Approach
10%	20%	70%	0.656	0.427	0.310	10%	90%	0.914	0.819	0.765
20%	20%	60%	0.641	0.435	0.313	20%	80%	0.842	0.694	0.619
30%	20%	50%	0.626	0.444	0.315	30%	70%	0.781	0.602	0.520
40%	20%	40%	0.613	0.453	0.317	40%	60%	0.728	0.531	0.449
70%	20%	10%	0.575	0.483	0.325	50%	50%	0.681	0.476	0.394
60%	20%	20%	0.587	0.472	0.322	60%	40%	0.640	0.430	0.352
50%	20%	30%	0.600	0.462	0.320	70%	30%	0.604	0.393	0.317
40%	20%	40%	0.613	0.453	0.317	80%	20%	0.572	0.362	0.289
10%	30%	60%	0.683	0.461	0.340					
20%	30%	50%	0.667	0.471	0.343					
30%	30%	40%	0.651	0.481	0.346					
40%	30%	30%	0.637	0.491	0.349					
60%	30%	10%	0.609	0.514	0.355					
50%	30%	20%	0.623	0.503	0.352					
40%	30%	30%	0.637	0.491	0.349					
30%	30%	40%	0.651	0.481	0.346					
10%	40%	50%	0.713	0.501	0.376					
20%	40%	40%	0.695	0.512	0.379					
30%	40%	30%	0.678	0.525	0.383					
40%	40%	20%	0.662	0.537	0.386					
50%	40%	10%	0.647	0.551	0.390					
40%	40%	20%	0.662	0.537	0.386					
30%	40%	30%	0.678	0.525	0.383					
20%	40%	40%	0.695	0.512	0.379					

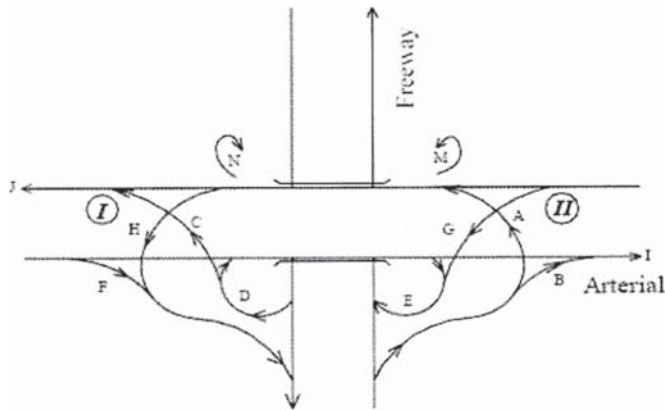

Figure B-6. Illustration of origin-destination demands through a PARCLO AB-2Q interchange.

Abbreviations and acronyms used without definitions in TRB publications:

AAAE	American Association of Airport Executives
AASHO	American Association of State Highway Officials
AASHTO	American Association of State Highway and Transportation Officials
ACI-NA	Airports Council International-North America
ACRP	Airport Cooperative Research Program
ADA	Americans with Disabilities Act
APTA	American Public Transportation Association
ASCE	American Society of Civil Engineers
ASME	American Society of Mechanical Engineers
ASTM	American Society for Testing and Materials
ATA	Air Transport Association
ATA	American Trucking Associations
CTAA	Community Transportation Association of America
CTBSSP	Commercial Truck and Bus Safety Synthesis Program
DHS	Department of Homeland Security
DOE	Department of Energy
EPA	Environmental Protection Agency
FAA	Federal Aviation Administration
FHWA	Federal Highway Administration
FMCSA	Federal Motor Carrier Safety Administration
FRA	Federal Railroad Administration
FTA	Federal Transit Administration
IEEE	Institute of Electrical and Electronics Engineers
ISTEA	Intermodal Surface Transportation Efficiency Act of 1991
ITE	Institute of Transportation Engineers
NASA	National Aeronautics and Space Administration
NASAO	National Association of State Aviation Officials
NCFRP	National Cooperative Freight Research Program
NCHRP	National Cooperative Highway Research Program
NHTSA	National Highway Traffic Safety Administration
NTSB	National Transportation Safety Board
SAE	Society of Automotive Engineers
SAFETEA-LU	Safe, Accountable, Flexible, Efficient Transportation Equity Act: A Legacy for Users (2005)
TCRP	Transit Cooperative Research Program
TEA-21	Transportation Equity Act for the 21st Century (1998)
TRB	Transportation Research Board
TSA	Transportation Security Administration
U.S.DOT	United States Department of Transportation