

Measuring Tire-Pavement Noise at the Source

DETAILS

36 pages | | PAPERBACK

ISBN 978-0-309-11768-5 | DOI 10.17226/14212

AUTHORS

Paul R Donavan; Dana M Lodico; Transportation Research Board

BUY THIS BOOK

FIND RELATED TITLES

Visit the National Academies Press at NAP.edu and login or register to get:

- Access to free PDF downloads of thousands of scientific reports
- 10% off the price of print titles
- Email or social media notifications of new titles related to your interests
- Special offers and discounts



Distribution, posting, or copying of this PDF is strictly prohibited without written permission of the National Academies Press. (Request Permission) Unless otherwise indicated, all materials in this PDF are copyrighted by the National Academy of Sciences.

NCHRP REPORT 630

**Measuring Tire-Pavement
Noise at the Source**

Paul R. Donovan

Dana M. Lodico

ILLINGWORTH & RODKIN, INC.

Petaluma, CA

Subject Areas

Materials and Construction

Research sponsored by the American Association of State Highway and Transportation Officials
in cooperation with the Federal Highway Administration

TRANSPORTATION RESEARCH BOARD

WASHINGTON, D.C.

2009

www.TRB.org

NATIONAL COOPERATIVE HIGHWAY RESEARCH PROGRAM

Systematic, well-designed research provides the most effective approach to the solution of many problems facing highway administrators and engineers. Often, highway problems are of local interest and can best be studied by highway departments individually or in cooperation with their state universities and others. However, the accelerating growth of highway transportation develops increasingly complex problems of wide interest to highway authorities. These problems are best studied through a coordinated program of cooperative research.

In recognition of these needs, the highway administrators of the American Association of State Highway and Transportation Officials initiated in 1962 an objective national highway research program employing modern scientific techniques. This program is supported on a continuing basis by funds from participating member states of the Association and it receives the full cooperation and support of the Federal Highway Administration, United States Department of Transportation.

The Transportation Research Board of the National Academies was requested by the Association to administer the research program because of the Board's recognized objectivity and understanding of modern research practices. The Board is uniquely suited for this purpose as it maintains an extensive committee structure from which authorities on any highway transportation subject may be drawn; it possesses avenues of communications and cooperation with federal, state and local governmental agencies, universities, and industry; its relationship to the National Research Council is an insurance of objectivity; it maintains a full-time research correlation staff of specialists in highway transportation matters to bring the findings of research directly to those who are in a position to use them.

The program is developed on the basis of research needs identified by chief administrators of the highway and transportation departments and by committees of AASHTO. Each year, specific areas of research needs to be included in the program are proposed to the National Research Council and the Board by the American Association of State Highway and Transportation Officials. Research projects to fulfill these needs are defined by the Board, and qualified research agencies are selected from those that have submitted proposals. Administration and surveillance of research contracts are the responsibilities of the National Research Council and the Transportation Research Board.

The needs for highway research are many, and the National Cooperative Highway Research Program can make significant contributions to the solution of highway transportation problems of mutual concern to many responsible groups. The program, however, is intended to complement rather than to substitute for or duplicate other highway research programs.

NCHRP REPORT 630

Project 1-44
ISSN 0077-5614
ISBN: 978-0-309-11768-5
Library of Congress Control Number 2009900077

© 2009 Transportation Research Board

COPYRIGHT PERMISSION

Authors herein are responsible for the authenticity of their materials and for obtaining written permissions from publishers or persons who own the copyright to any previously published or copyrighted material used herein.

Cooperative Research Programs (CRP) grants permission to reproduce material in this publication for classroom and not-for-profit purposes. Permission is given with the understanding that none of the material will be used to imply TRB, AASHTO, FAA, FHWA, FMCSA, FTA, or Transit Development Corporation endorsement of a particular product, method, or practice. It is expected that those reproducing the material in this document for educational and not-for-profit uses will give appropriate acknowledgment of the source of any reprinted or reproduced material. For other uses of the material, request permission from CRP.

NOTICE

The project that is the subject of this report was a part of the National Cooperative Highway Research Program conducted by the Transportation Research Board with the approval of the Governing Board of the National Research Council. Such approval reflects the Governing Board's judgment that the program concerned is of national importance and appropriate with respect to both the purposes and resources of the National Research Council.

The members of the technical committee selected to monitor this project and to review this report were chosen for recognized scholarly competence and with due consideration for the balance of disciplines appropriate to the project. The opinions and conclusions expressed or implied are those of the research agency that performed the research, and, while they have been accepted as appropriate by the technical committee, they are not necessarily those of the Transportation Research Board, the National Research Council, the American Association of State Highway and Transportation Officials, or the Federal Highway Administration, U.S. Department of Transportation.

Each report is reviewed and accepted for publication by the technical committee according to procedures established and monitored by the Transportation Research Board Executive Committee and the Governing Board of the National Research Council.

The Transportation Research Board of the National Academies, the National Research Council, the Federal Highway Administration, the American Association of State Highway and Transportation Officials, and the individual states participating in the National Cooperative Highway Research Program do not endorse products or manufacturers. Trade or manufacturers' names appear herein solely because they are considered essential to the object of this report.

Published reports of the

NATIONAL COOPERATIVE HIGHWAY RESEARCH PROGRAM

are available from:

Transportation Research Board
Business Office
500 Fifth Street, NW
Washington, DC 20001

and can be ordered through the Internet at:

<http://www.national-academies.org/trb/bookstore>

Printed in the United States of America

THE NATIONAL ACADEMIES

Advisers to the Nation on Science, Engineering, and Medicine

The **National Academy of Sciences** is a private, nonprofit, self-perpetuating society of distinguished scholars engaged in scientific and engineering research, dedicated to the furtherance of science and technology and to their use for the general welfare. On the authority of the charter granted to it by the Congress in 1863, the Academy has a mandate that requires it to advise the federal government on scientific and technical matters. Dr. Ralph J. Cicerone is president of the National Academy of Sciences.

The **National Academy of Engineering** was established in 1964, under the charter of the National Academy of Sciences, as a parallel organization of outstanding engineers. It is autonomous in its administration and in the selection of its members, sharing with the National Academy of Sciences the responsibility for advising the federal government. The National Academy of Engineering also sponsors engineering programs aimed at meeting national needs, encourages education and research, and recognizes the superior achievements of engineers. Dr. Charles M. Vest is president of the National Academy of Engineering.

The **Institute of Medicine** was established in 1970 by the National Academy of Sciences to secure the services of eminent members of appropriate professions in the examination of policy matters pertaining to the health of the public. The Institute acts under the responsibility given to the National Academy of Sciences by its congressional charter to be an adviser to the federal government and, on its own initiative, to identify issues of medical care, research, and education. Dr. Harvey V. Fineberg is president of the Institute of Medicine.

The **National Research Council** was organized by the National Academy of Sciences in 1916 to associate the broad community of science and technology with the Academy's purposes of furthering knowledge and advising the federal government. Functioning in accordance with general policies determined by the Academy, the Council has become the principal operating agency of both the National Academy of Sciences and the National Academy of Engineering in providing services to the government, the public, and the scientific and engineering communities. The Council is administered jointly by both the Academies and the Institute of Medicine. Dr. Ralph J. Cicerone and Dr. Charles M. Vest are chair and vice chair, respectively, of the National Research Council.

The **Transportation Research Board** is one of six major divisions of the National Research Council. The mission of the Transportation Research Board is to provide leadership in transportation innovation and progress through research and information exchange, conducted within a setting that is objective, interdisciplinary, and multimodal. The Board's varied activities annually engage about 7,000 engineers, scientists, and other transportation researchers and practitioners from the public and private sectors and academia, all of whom contribute their expertise in the public interest. The program is supported by state transportation departments, federal agencies including the component administrations of the U.S. Department of Transportation, and other organizations and individuals interested in the development of transportation. www.TRB.org

www.national-academies.org

COOPERATIVE RESEARCH PROGRAMS

CRP STAFF FOR NCHRP REPORT 630

Christopher W. Jenks, *Director, Cooperative Research Programs*
Crawford F. Jencks, *Deputy Director, Cooperative Research Programs*
Amir N. Hanna, *Senior Program Officer*
Eileen P. Delaney, *Director of Publications*
Maria Sabin Crawford, *Assistant Editor*

NCHRP PROJECT 1-44 PANEL **Field of Design—Area of Pavements**

Matthew W. Mueller, *Illinois DOT, Springfield, IL (Chair)*
Randell H. “Randy” Iwasaki, *California DOT, Sacramento, CA*
German J. Claros, *Texas DOT, Austin, TX*
Larry Lockett, *Alabama DOT, Montgomery, AL*
David E. Newcomb, *National Asphalt Pavement Association, Lanham, MD*
John H. Roberts, *American Concrete Pavement Association, Coxsackie, NY*
Judith L. Rochat, *Research and Innovative Technology Administration, Cambridge, MA*
Larry A. Scofield, *American Concrete Pavement Association, Mesa, AZ (formerly with Arizona DOT)*
Roger L. Wayson, *University of Central Florida, Orlando, FL*
Robert Orthmeyer, *FHWA Liaison*
Mark Swanlund, *FHWA Liaison*
Frederick Hejl, *TRB Liaison*

AUTHOR ACKNOWLEDGMENTS

The research reported in this document was performed under NCHRP Project 1-44 by Illingworth & Rodkin, Inc., Petaluma, California. Dr. Paul Donovan was the Principal Investigator. Ms. Dana Lodico of Illingworth & Rodkin, Inc., participated in the data acquisition and analysis and was the second author of this report. Chris Peters also of Illingworth & Rodkin, Inc., assisted in the fieldwork. The National Center of Asphalt Technology, Auburn, Alabama, served as a subcontractor for this research.

The authors acknowledge the assistance provided by MnDOT personnel at the MnRoads test facility in Minnesota and the assistance provided by General Motors personnel at the GM Desert Proving Ground test facility in Arizona during the test parameter investigation phase of this work. The authors also extend their gratitude to Dr. James Cable of Iowa State University for his assistance in identifying test sites in Iowa and coordinating the assistance provided by Mr. Bruce Rymer of Caltrans in coordinating test site usage in the State of California.

FOREWORD

By Amir N. Hanna

Staff Officer

Transportation Research Board

This report presents a suggested procedure for measuring tire-pavement noise at the source. The procedure uses the on-board sound intensity (OBSI) method that was found to be the preferred approach for measuring tire-pavement noise at the source. Although the research presented in this report provided a basis for the recently introduced provisional Standard Test Method for the Measurement of Tire/Pavement Noise Using the On-Board Sound Intensity (OBSI) Method (AASHTO Designation TP076-08), the procedure includes some modifications to the provisional standard. The content of the report will be of immediate interest to state engineers and others concerned with pavement design and construction and the noise impacts on nearby communities.

Tire-pavement noise has become an increasingly important consideration for highway agencies as the public consistently demands that highway traffic noise be mitigated. Although sound walls provide a means for addressing highway noise, improved pavement structures and surfaces may provide a competitive alternative for noise mitigation. However, there are no widely accepted procedures for measuring solely tire-pavement noise under in-service conditions. Thus, research was needed to evaluate potential noise-measuring procedures and identify or develop appropriate procedures applicable to light and heavy vehicles and all paved surfaces.

Under NCHRP Project 1-44, "Measuring Tire-Pavement Noise at the Source," Illingworth and Rodkin, Inc., of Petaluma, California, worked with the objectives of (1) developing rational procedures for measuring tire-pavement noise and (2) demonstrating applicability of the procedures through testing of in-service pavements. To accomplish these objectives, the researchers (1) reviewed current practices, approaches, and methods used for measuring tire-pavement noise in close proximity of the tire; (2) conducted tests to evaluate candidate methods and select the most promising test method; (3) examined the parameters associated with the selected test method to identify appropriate parameter limits; and (4) conducted measurements on in-service pavements to demonstrate applicability of the selected method to different pavement types. Based on this review and analysis of test results, the research suggested a procedure for measuring tire-pavement noise using the sound-intensity method. The test procedure will be particularly useful to highway agencies in considering noise issues because it provides an appropriate means for (1) measuring and rating tire-pavement noise levels on existing pavements, (2) evaluating new pavements incorporating noise-mitigating features, and (3) identifying design and construction features associated with different noise levels.

Appendixes A through D contained in the research agency's final report provide detailed information on the literature review, the experimental program, data analysis, and demon-

stration testing of the suggested method. These appendixes are not published herein, but are available online at http://trb.org/news/blurp_detail.asp?id=9956. These appendixes are titled as follows:

Appendix A: Review of Literature

Appendix B: Test Evaluation of Candidate Methods and Recommendation for Test Procedure Development

Appendix C: Results of Test Parameter Evaluation

Appendix D: Demonstration Testing of OBSI Procedure

CONTENTS

1	Summary
2	Chapter 1 Introduction
2	Background
3	Research Objectives and Scope
3	Research Approach
4	Chapter 2 Literature Search
4	Description of the Review
5	Remarks on Test Procedure Development
7	Chapter 3 Evaluation of Alternative Test Methods
7	Overview of Evaluation Testing
7	Summary of the CPX and OBSI Test Results
9	Recommendation of an At-the-Source Measurement Method
11	Chapter 4 Evaluation of OBSI Test Parameters
11	Introduction
11	Description of Field Measurements
11	Parameters Evaluated
11	Measurement Sites
11	Measurement Protocol
12	Meteorological Conditions
12	Results of Parameter Investigation
12	Run-to-Run Repeatability of Baseline Condition
13	Test Tire (SRTT versus Dunlop)
14	Environmental Variables
14	Systematic Vehicle and Test Execution Variables
15	Test Vehicle
16	Fixture Configuration (Single Probe versus Dual Probe)
16	Data Quality Criteria
16	Recommendations on Parameter Limits
17	Chapter 5 Demonstration Testing of OBSI Procedure
17	Introduction
17	Description of Field Measurements
17	Measurement Sites
17	Measurement Protocol
18	Meteorological Conditions
19	Data Reduction and Analysis
19	Data Reduction
19	Data Analysis

20	Results and Discussion
20	Normalized SPB and CPB Data versus OBSI
23	Prediction of SPB Data from OBSI Data
27	Test Tires
27	Summary
29	Chapter 6 Conclusions, Recommendations, and Suggested Research
29	Conclusions
29	Recommendations
30	Test Procedure Implementation and Enhancement
30	Other Recommendations
30	Suggested Research
31	References
32	Attachment Proposed Method of Test for Measurement of Tire-Pavement Noise Using the On-Board Sound Intensity (OBSI) Method
36	Appendixes A, B, C, and D

S U M M A R Y

Measuring Tire-Pavement Noise at the Source

The objectives of this research were to (1) develop rational procedures for measuring tire-pavement noise at the source and (2) demonstrate the applicability of the procedures through testing of in-service pavements. At the beginning of this project, a literature review was performed to identify and evaluate various approaches to measuring on-board tire-pavement noise and to assess if any of these methods were appropriate for development in this research. As a result of this review, two potential candidates were identified, the close proximity (CPX) and on-board sound intensity (OBSI) methods. Field-testing was conducted to assess the two candidate methods and to compare their respective ability to correlate with controlled passby measurements of a test vehicle equipped with tires of two different designs. The two at-the-source measurements correlated well with each other, and to a lesser degree, with the passby measurements. For two of the test sites, differences in sound propagation were found to contribute significantly to the reduced correlation of the CPX and OBSI data to the passby data. Once these differences were considered, adequate correlation to passby data was found for both methods with a slightly better correlation using the OBSI data. It was further found that the CPX results had some distortion in the $\frac{1}{2}$ octave band spectra in comparison to both the passby and OBSI results. For these reasons, with consideration to practicality, the OBSI method was selected for further development into an at-the-source tire-pavement noise procedure.

To further develop the OBSI procedure, testing was conducted to examine the effect of measurement variables on the repeatability of data obtained using the procedure. This testing identified the OBSI probe location in the vertical direction, vehicle speed, and vehicle loading to be the factors contributing to the variation for the ranges and parameters evaluated. Within reasonable limits, probe distance from the tire, probe fore/aft location, and tire inflation pressure were found not to be critical. Based on these results, parameter limits were established for the OBSI procedure.

Following the initial draft OBSI test procedure, testing was performed to demonstrate the applicability of the OBSI method to characterizing the in-service noise performance of pavements. In this testing, OBSI, controlled passby (CPB), and statistical passby (SPB) measurements were made on 12 sites with different pavement structures in Iowa and California. Test data were used to examine the relationship between OBSI and both types of passby measurements. The CPB-to-OBSI comparisons indicated that site-to-site variation due to the geometric and acoustic properties was significant. Using these data, it was possible to normalize site-specific effects out of the SPB data. It was also demonstrated that the SPB results could be accurately predicted from the OBSI data for a typical site defined by the average of the sites included in the investigation.

With the completion of the field measurements and data analysis, a revised draft OBSI test procedure was prepared (see Attachment).

CHAPTER 1

Introduction

Tire-pavement noise has become an increasingly important consideration for highway agencies. However, there are no widely accepted procedures for measuring solely tire-pavement noise under in-service conditions. As a result, this research was undertaken to evaluate potential noise-measuring procedures and identify or develop appropriate procedures applicable to light and heavy vehicles and all paved surfaces. Such procedures will provide highway agencies with an appropriate means for (1) measuring and rating tire-pavement noise levels on existing pavements, (2) evaluating new pavements incorporating noise-mitigating features, and (3) identifying design and construction features associated with different noise levels.

The objectives of this research were to (1) develop rational procedures for measuring tire-pavement noise at the source and (2) demonstrate the applicability of the procedures through testing of in-service pavements. To achieve these objectives, (1) a literature search was conducted to gain understanding of what approaches have been used in the past to quantify tire-pavement noise source levels, (2) evaluation testing was conducted to assess candidate methods and select the most promising one, (3) the effect of test parameters of the selected method were examined to develop parameter limits, and (4) field tests were performed on in-service pavements to demonstrate the applicability of the proposed measurement method for different pavement types. This report presents the results of the research, the information obtained, implications for developing a rational test procedure, and the proposed test method.

Background

Recently, there has been increased interest on the part of highway agencies to consider the use of quieter pavements to mitigate traffic noise. This interest has been driven largely by the cost and, at times, lack of public acceptance of the traditional sound wall approach to mitigating traffic noise (1) and an apparent increase in the demands of the public for highway

traffic noise reduction. In addition, there has been an increasing public awareness that pavement selection can affect the resultant traffic noise levels.

An increased interest in measuring tire-pavement noise at the source has occurred parallel to the recent interest in quiet pavements. With this type of testing, acoustic measurements are made close to the tire-pavement interface with instrumentation that translates with the test tire. Thus, the tire-pavement noise of a large number of pavements can be measured in a relatively short period of time with very few restrictions on the test site. The source-level measurements require less time and fewer resources to complete relative to wayside measurements and facilitate a more direct comparison of tire-pavement noise generation from one site to another. However, there are no widely accepted procedures in the United States for tire-pavement noise source levels under in-service conditions.

When this research began, tire-pavement noise source-level measurements in the United States primarily used two approaches, the Close Proximity (CPX) method as documented in the draft ISO 11819-2 standard document (2), and the On Board Sound Intensity (OBSI) method based on techniques developed at General Motors Corporation (3). In the early 2000s, both of these methods were used to catalogue and compare different pavements for their noise performance (4, 5, 6). Other methods using different approaches of sound pressure level measurement (7) and near field acoustical holography (8) were also reported in the literature. As a result of the uncertainty inherent in the measurement procedures of tire-pavement noise source levels, development of standardized procedures was identified as a research need by the AASHTO Standing Committee on Research in March of 2004; the Committee allocated funds to develop such procedures under NCHRP Project 1-44. This need was also reiterated at the first Tire-Pavement Noise Strategic Planning Workshop conducted by the Federal Highway Administration and the Institute for Safe, Quiet, and Durable Highways held at Purdue University in September of 2004 (9). The research conducted in this proj-

ect was subsequently initiated with the objective of developing a rational procedure for measuring tire-pavement noise at the source that could be implemented by highway agencies.

Research Objectives and Scope

The objectives of this research were to (1) develop rational procedures for measuring tire-pavement noise at the source and (2) demonstrate the applicability of the procedures through testing of in-service pavements. This work was divided into two Phases. Phase I of this project involved reviewing the relevant literature worldwide as documented in conference proceedings, technical papers, and other sources; evaluating the several candidate techniques identified from the literature; and then selecting a single approach for measuring tire-pavement noise at the source for further development. In Phase II, the effect of test parameters was examined and field tests were performed on in-service pavements to compare source level, controlled vehicle passby, and statistical passby data collection. The results were used to develop a recommended test procedure for the measurement of tire-pavement noise at the source.

Research Approach

The research was performed in two phases comprising six tasks. Phase I included the following four tasks (1 through 4):

1. *Identify Potential Tire-Pavement Noise Measurement Methods.* In this task, information on methods for measuring tire-pavement noise at the source was collected, reviewed, and synthesized. The findings of this literature search are summarized in Chapter 2 and documented in more detail in Appendix A.
2. *Develop Recommendation for Tire-Pavement Test Method.* The test methods identified in Task 1 were evaluated in regard to their potential for providing a rational test procedure for measuring tire-pavement noise at the source. Based on this evaluation, two candidate techniques were identified for further investigation: CPX and OBSI. In order to develop a single recommended method, several subtasks were performed. First, the two candidate techniques were evaluated in experiments conducted at and around the National Center for Asphalt Technology (NCAT) test track facility in Opelika, Alabama. CPX, OBSI, and controlled wayside passby noise levels were

measured on a variety of pavement types using the same tires. Next, the results of the CPX and OBSI testing were analyzed and ranked on the basis of their ability to correlate with the wayside passby levels. In addition, consideration was given to the expense/practicality and training/expertise required for each method. Under the final subtask, the OBSI method was recommended as the basis of the procedure to be demonstrated and refined in Phase II based on the ranking of the techniques and their ability to meet the other identified criteria developed in Task 1.

3. *Develop Work Plan to Demonstrate Recommended Method.* In this task, a work plan for Phase II of the project was developed.
4. *Documentation and Interim Report.* In this task, an interim report of the research performed in Tasks 1 through 3 was prepared. The report included the results of survey work of Task 1, the experimental work and recommendations of Task 2, and the updated and detailed work plan for Phase II developed in Task 3.

Phase II included the following two tasks (5 and 6):

5. *Field Measurements, Analysis, and Findings.* This task included three subtasks. The first subtask was the evaluation of repeatability issues and parameter dependencies of the OBSI method using a preliminary test procedure. This evaluation was accomplished through testing conducted at Minnesota's DOT MnROAD Low Volume Road facility in Albertville, Minnesota, and at the General Motors Desert Proving Ground (DPG) in Mesa, Arizona. The second subtask was the assessment of the applicability of the OBSI procedure through the testing of in-service pavements. This work consisted of conducting controlled vehicle passby, statistical passby, and tire-pavement noise OBSI measurements on 12 in-service pavement sections in Iowa and California. These tests included the simultaneous measurement of (1) OBSI on two specific candidate test tires, (2) controlled passbys on test vehicles equipped with those tires, and (3) statistical passbys of both light and heavy-duty vehicles. The third subtask involved the development of a draft OBSI procedure based on the results obtained through the test parameter investigation and the results of the in-service pavement testing.
 6. *Prepare Final Report.* In this task, a report documenting the research, findings, and recommendations resulting from this research was prepared.
-

CHAPTER 2

Literature Search

Hundreds of papers have been written on the subject of tire-pavement noise. Relevant references were read, summarized, and grouped into categories based on the measurement types employed. Studies that dealt with measurements on pavements (not on “road-wheels” in a laboratory environment) that were not limited to passby or wayside measurements were selected for review. Selected papers were examined for the use of a novel approach, the development of a source-level measurement approach, or the comparison of passby to source-level measurements. Papers that gave results comparing passby to source-level measurements were reviewed in the most detail. References discussing testing parameters and/or variables that affect tire noise measurements were also reviewed. Nearly 100 sources of information were evaluated in this manner (detailed results of this work and a complete reference list are provided in Appendix A).

Description of the Review

The primary source of reference material was papers written for various noise conferences. The proceedings of over 100 national and international conferences and symposia have been searched for work related to tire-pavement noise measurement at the source. *The Tyre/Road Noise Reference Book* (10) has been used as a check ensuring that the relevant work prior to 2001 has been included in the search. However, material from the 1970s through 2001 was searched independently of this reference in order to ensure inclusion of all related work. In more recent years (2002 through 2005), many additional papers were published on this subject from ongoing work in Europe, the United States, and Asia. The literature deals with three general categories of acoustic measurement: sound pressure level (SPL) measurements, sound intensity (SI) level measurements, and sound field measurements using acoustic array technology (AAT).

The sound pressure level measurement approaches may be divided into three subcategories. The first of these are variations of “behind the tire” (BTT) measurements where a microphone is placed directly behind the tire typically close to both the tire and pavement. This position was chosen because it was thought to reduce wind noise on the microphone. The second subcategory is the so-called “close proximity” measurement where several microphones are placed at various points around the tire (Figure 1). This approach evolved into the formal ISO Draft Standard procedure, ISO 11819-2 (2), which is commonly referred to as the Close Proximity (CPX) method. Use of slightly different microphone positions than those used in this draft standard was reported. The CPX approach includes techniques where the microphones are protected from airflow by trailers surrounding the test tire and those where the microphones are exposed to flow. The third subcategory is all other SPL measurements that are not included in BTT and CPX approaches and are typically unique to a single study or set of studies by an individual researcher or research group if referred to as “SPL Other.”

In the SI category, the majority of the reported studies follow the approach developed at General Motors Corporation (GM) and documented in the relevant GM Test Procedure (11) (Figure 2) although several other unique approaches were also reported. In the AAT category, almost all of on-road work uses a near-field acoustic holography approach (NAH) and has been done largely by a single research effort at Penn State University (8).

Each of the three major measurement categories has been used both for on-road and road-wheel (RW) testing. Although it was the intent of this project to develop a procedure for in situ measurement of tire-pavement noise at the source, some of the RW work is of interest and was included in the review. Also included in the review were a few references dealing with measurements that were important to understanding tire-pavement noise variables as they relate to a test procedure.



Figure 1. CPX tire-pavement noise measurement configuration.

Remarks on Test Procedure Development

In this subsection, the implications of the literature search on the selection of the candidate test method are summarized. This draws upon the complete discussion of the literature search provided in Appendix A, which includes the citation of 85 references.

Of the three overall approaches, AAT methods appear to be the furthest away from being a usable technique for routine, in-service pavement noise evaluation. These techniques have never been applied to measurements in a highway environment and no comparisons to passby data have been



Figure 2. OBSI single probe position opposite the leading edge of the tire contact patch.

reported. The measurement systems are not standardized and require acquisition and manipulation of many channels of acoustic signals. Considering the similarity of results provided by sound intensity and AAT mapping, there appears to be no advantage in pursuing AAT technology over the simpler OBSI methods.

For SPL measurements, a lot of different approaches have been cited in the literature. Some of the early work using BTT methods displayed some limited level of correlation to passby measurement for trucks. However, more recent research work has shown that the noise region at the front of the tire is equally important to overall tire noise and that there is little correlation between the front and the rear of the tire. Of the remainder of the SPL methods, there appears to be no justification for following any method other than that defined in the ISO CPX draft standard. Comparisons between passby and onboard measurements using other SPL methods show about the same degree of correlation as seen with CPX methods. Regarding the CPX approaches, some consideration should be given to using trailer instead of exposed microphones. With the trailer method, concern has been expressed about reflections in the enclosure. Tests to evaluate reflections have been defined; however, recent work comparing different tests and equipment have indicated some variation. An attractive alternative to the trailer-based CPX method is the exposed microphone technique. With the microphones fixed to the side of the test vehicle, this approach should avoid the build up of reflections and should be less expensive to implement. However, the issue of flow noise contamination of the exposed microphone remains unresolved and methods for testing for it are not defined.

As with the CPX method, the OBSI method using the GM methodology has been used extensively for in situ highway pavement noise measurements. This method has been shown to correlate reasonably well with both controlled passby (CPB) data and CPX data. Unlike the test tires specified in the ISO CPX draft standard, tires used today in OBSI testing seemed to be somewhat arbitrary relative to “typical” tire noise as little data comparing OBSI to statistical passby (SPB) for light vehicles has been reported. Further, the use of consumer tires for standardized testing is problematic as tire suppliers discontinue production of these tires, as has been experienced both by users of the CPX and OBSI methods. International availability of test tires has also been an issue as some test tires used in Europe are not available in the United States and vice versa. For the onboard procedure to be used by highway agencies in the United States, the selection and availability of test tires must be considered regardless of the test procedure used.

An issue that remains an unknown is relating either CPX or OBSI measurements to passby levels of porous pavements.

Differences between CPX to CPB or SPB relationships have been reported in some European studies. Also, one study suggested that porosity played a role in CPB and OBSI data measured for two test surfaces, one slightly porous and one non-porous (12). Differences may also exist in the way in which these two methods respond to porous pavement and how they relate to passby levels.

Prior to this study, there had been no research to compare OBSI to CPX and both to CPB within the same study. Such information is necessary in order to assess the technical merits of both approaches and to determine if there is a technical advantage in one of the approaches that should be considered along with other, non-technical issues. The evaluation testing of these two methods is reported in Chapter 3.

CHAPTER 3

Evaluation of Alternative Test Methods

Based on the results of the literature search, testing was conducted to evaluate the two candidate methods for on-board, tire-pavement noise source measurement. This testing consisted of measuring CPX and OBSI noise levels on the same tires and then conducting controlled passby measurements using the test tires along with three other tires of the same design mounted on the test vehicle. The findings from this testing along with other considerations leading to the selection of the OBSI method of tire-pavement noise measurement at the source are summarized in this section (details of the testing and analyses are discussed in Appendix B).

Overview of Evaluation Testing

Passby measurements were made under both cruise and coast conditions. Sound pressure levels of tire-pavement noise at the source were measured in a manner following the ISO CPX test procedure (2). Sound intensity levels were measured using the OBSI methodology employed in previous California Department of Transportation (Caltrans) studies (6). OBSI levels were also measured on the CPX trailer for comparison to those measured on the test car. In addition to these measurements, testing was done to examine potential propagation differences between sites. Measurements were made at five sites: four asphalt concrete (AC) pavements at the National Center for Asphalt Technology (NCAT) test track in Auburn, Alabama, and one portland cement concrete (PCC) pavement in the nearby town of Waverly, Alabama (specific information on these sites and pavements is provided in Appendix B). Three of the pavements at NCAT were acoustically hard, producing no sound absorption. Surfaces for these sections were fine texture Superpave (Section AC S5), medium texture stone mastic asphalt (Section AC S1), and Superpave with added transverse texture (Section AC W5). The fourth pavement had a porous, open-graded asphalt concrete (OGAC) pavement of coarse texture in the travel lane with propagation over an adjacent non-porous AC lane (Section AC S4). The Waverly site

(Waverly PCC) had an old PCC surface with transverse slab joints, no roadway shoulder, and propagation over an acoustically softer ground, providing some degree of sound absorption. At the NCAT track, test speeds of 35, 45, and 60 mph were measured at all four sites, except for AC W5 where 55 mph was substituted for 60 mph due to track banking. At Waverly, only 35 and 45 mph were tested due to posted speed restrictions. An example passby measurement setup is shown in Figure 3 for the Waverly test site. Photographs showing typical CPX and OBSI measurement setups were shown in Chapter 2. Specific information regarding the test sites, test matrix, and test methods is given in Appendix B.

Three sets of tires were used for the testing (see Figure 4, details of the test tires are documented in Appendix B). One of these tires is the ASTM Standard Reference Test Tire (SRTT) (13), which is currently under study by the ISO Working Group 33 as a possible new standard test tire for the ISO CPX procedure. Another tire was a Dunlop SP Winter Sport M3. This tire has been used in round-robin testing conducted by tire and vehicle manufacturers and was chosen by that group as a replacement for a light truck tire due to its more aggressive tread pattern. The size of both tire types was P225/60R16. The third tire design was the Goodyear Aquatred 3 in a P205/70R15 size. This tire design has been extensively used by a number of researchers since 2000. Due to tire and wheel size incompatibility, comparable passby measurements for the Aquatred tire could not be made. However, CPX and OBSI measurements were conducted at all of the test sites for all three tire designs to provide a linkage to the historical Aquatred data.

Summary of the CPX and OBSI Test Results

For the test evaluation of the CPX and OBSI methods, the overriding issue was how well the at-the-source measures correlate to passby data. The simplest way to compare the CPX and OBSI measurements to the passby data is to consider the

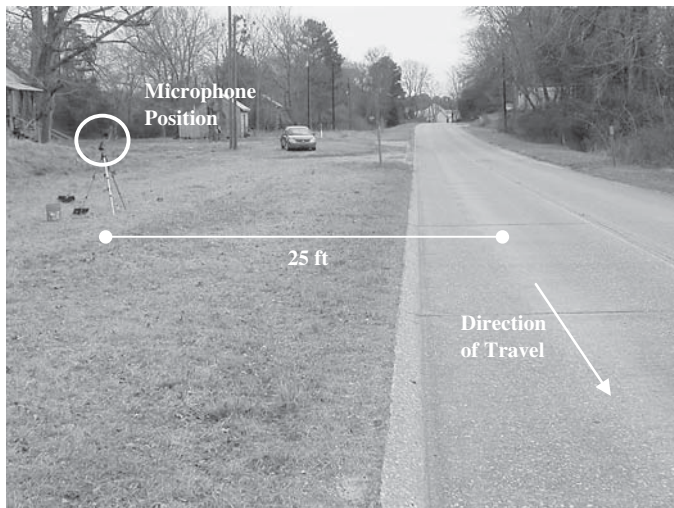

Figure 3. Passby measurement setup for the Waverly PCC test site.

cross-plots of overall A-weighted level and metrics generated by these plots. A typical cross-plot is shown in Figure 5 for CPX versus passby for all pavements and test speeds. From such plots, the slope and r^2 of a linear regression provide some indication of data scatter and deviation from an ideal constant offset (“1-to-1” fit). A 1-to-1 line (slope of 1) can also be constructed and deviations about that line considered. These are presented in Table 1 for the non-porous AC pavements (S1, S5, and W3), for all of the AC pavements (including the porous Section S4), and for all five sites grouped together.

For the first grouping of sites (left columns), there may be a slight advantage in favor of the OBSI measurements as the standard deviation about a 1-to-1 fit of the data is smaller than



Figure 4. Photograph of the Aquatred (left), Dunlop (middle), and SRTT (right) test tires.

that of the CPX measurements. When the porous pavement Section S4 is included, the standard deviations become identical (center columns). For this grouping, the only detractor for the CPX data is that the slope of linear regression deviates more from an ideal slope of 1 than do the OBSI results. For this grouping, both source measures correlate well to passby (even with the porous pavement included) as indicated by the r^2 values and standard and average deviations. With the scatter of the passby data being on the order of 1 to 2 dB, it is apparent that better correlation could not be expected for these sites. When the PCC site is included (right columns), this is not the case. Although the OBSI results hold some small advantage over the CPX, the r^2 and standard deviations for both are not very acceptable. From the sound propagation tests, the PCC site was found to be substantially different (2 to 4 dB) than the others due to sound absorption from the acoustically soft ground at the site and/or because the pavement was slightly depressed below the grade of the adjoining ground. These

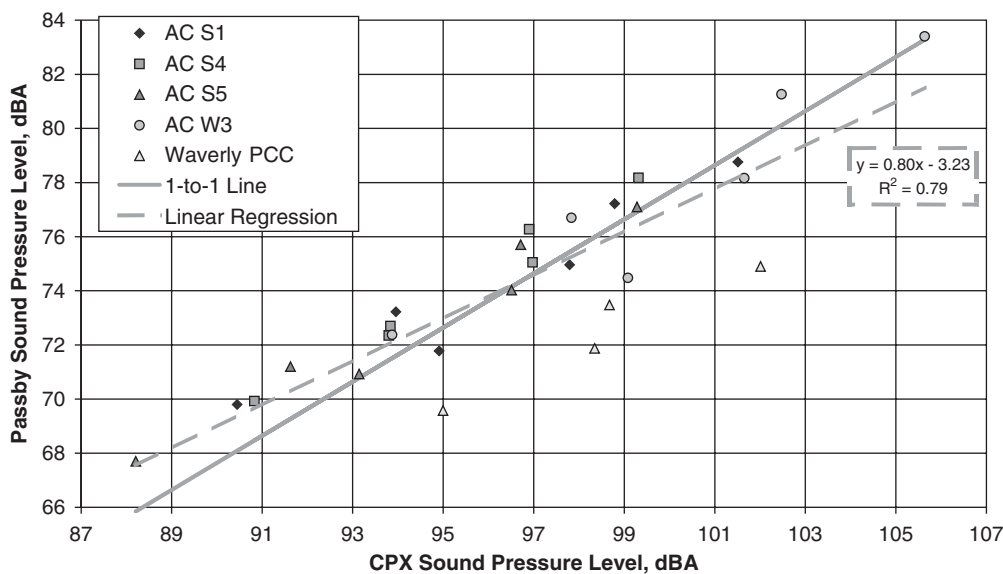

Figure 5. Controlled vehicle passby levels versus CPX sound pressure level for all test sites and both test tires.

Table 1. Correlation indicators for CPX and OBSI methods to passby.

Metric	Sections S1, S5, W3		Sections S1, S4, S5, W3		All Sites	
	CPX	OBSI	CPX	OBSI	CPX	OBSI
Slope	0.94	0.96	0.87	0.94	0.80	0.87
r^2	0.94	0.95	0.94	0.93	0.79	0.87
Offset, dB	21.9	23.7	21.7	24.0	22.4	24.6
Std Dev, dB	1.2	0.9	1.1	1.1	1.8	1.7
Avg. Dev, dB	1.0	0.7	0.8	0.9	1.4	1.3

data indicate that an at-the-source measurement cannot be expected to account for an arbitrary range of site characteristics in the prediction of wayside levels.

Further insight can be gained by plotting the overall CPX levels against the corresponding OBSI levels. These data suggest that CPX or OBSI source levels could be predicted from the other within a standard deviation of 1.1 dB when all of the test pavements are included (Figure 6). The standard deviation is reduced to 0.8 dB, however, when the porous AC Section S4 is excluded. It was noted that the two methods handle porous pavements differently. The actual passby levels were consistently higher than what would be predicted from the CPX to passby correlation curve, and consistently lower than what would be predicted from the OBSI to passby correlation. Thus, the CPX levels over-predict the effect of porosity on the passby levels while the OBSI levels under-predict it. This is likely due to the CPX sound pressure measurements being more affected by pavement sound absorption than the sound intensity measurement.

One of the largest drawbacks for the CPX method is spectral distortion which occurs in comparison to passby and OBSI results. In general, the 1/3 octave band levels below 1000 Hz

measured by the CPX method are consistently reduced by 3 to 4 dB relative to what would be expected from the passby spectra or the OBSI spectra as illustrated in the example presented in Figure 7. Although this spectral distortion has only subtle influence on the correlation of overall levels, some evidence of its effect was seen in the rank ordering of tires. The spectral distortion is thought to be related to the enclosure surrounding the test tire on the CPX trailer. Using the techniques currently under consideration by ISO Working Group 33, methods for determining corrections are being developed to account for the effects of the enclosure on the CPX measurements (14). However, unless trailers were totally identical, correction spectra would need to be determined for each CPX trailer.

Recommendation of an At-the-Source Measurement Method

The selection of the OBSI method for further development was based on both the technical issues resulting from the evaluation testing and from considerations dealing with the expense/practicality and training/expertise required for implementing either of the two methods (detailed analysis is

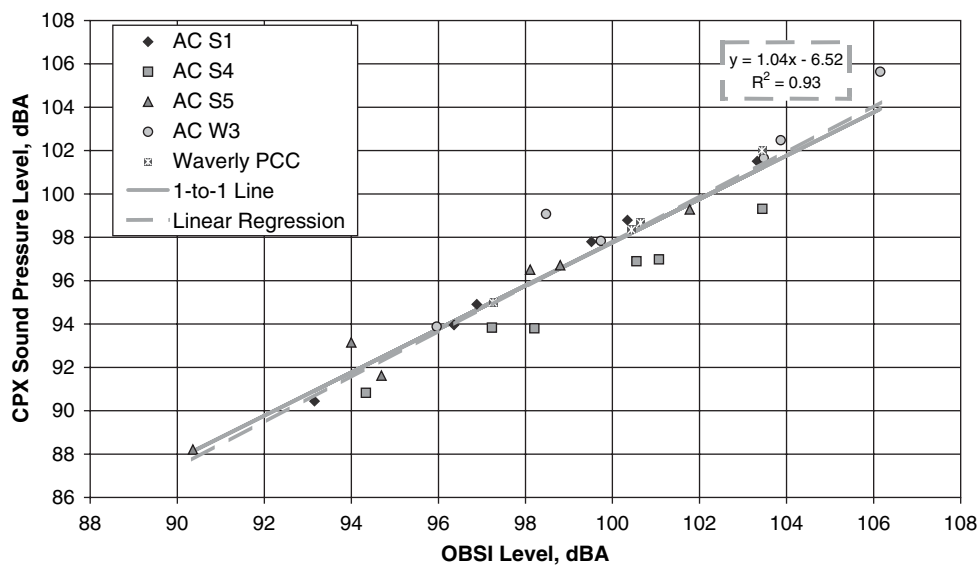

Figure 6. CPX sound pressure level versus OBSI level for all sites and both tires.

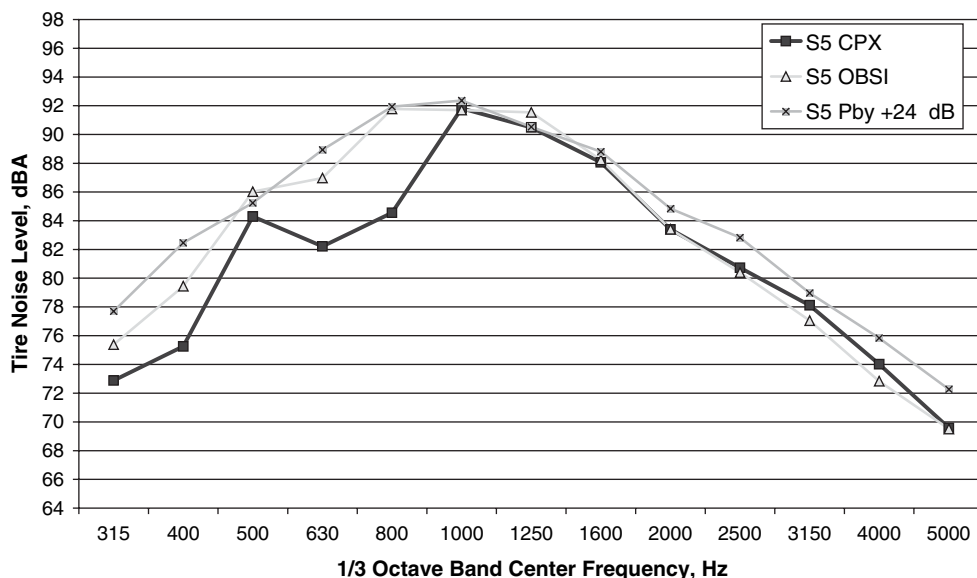

Figure 7. Comparison of spectra for CPX, OBSI, and passby levels with 24 dB added for Dunlop tire on Section AC S5 at 45 mph.

presented in Appendix B). In regard to expense and practicality, factors such as facilities expense, instrumentation costs, labor costs, and operational issues are associated with either method. For training and expertise, trade-offs between the two methods resulted in no net advantage for either method. The OBSI method was selected for the following reasons:

- Slightly better correlation between OBSI and passby data than for CPX data,
- Lack of spectral distortion seen in comparing OBSI and passby data,
- Expense of an enclosed trailer for CPX measurements, and

- Practical issues of acquiring, validating, operating, maintaining and storing a CPX trailer.

The first two reasons resulted from the evaluation testing; the last two reasons deal with the use of a CPX trailer. The option of exposed microphone CPX was considered desirable from a cost and ease of implementation point of view, but technical issues of wind noise, test vehicle reflections and noise, and operation in traffic would lead to inconsistency from one user to another. On the other hand, the issues against an OBSI approach do not appear to be significant enough to preclude its use.

CHAPTER 4

Evaluation of OBSI Test Parameters

Introduction

As explained in Chapter 3, the OBSI method was selected as a basis for developing an onboard, at-the-source measurement procedure for tire-pavement noise. As a portion of the work conducted to develop such a procedure, test variables and measurement uncertainties were examined. Based on input from current OBSI users as well as information contained in the draft ISO CPX procedure, some pertinent variables that could affect the measurement results were identified. The sensitivity of OBSI results to variations in pavement temperature, the configuration of the OBSI measurement fixture, tire inflation pressure, test vehicle type, test speed, and load were investigated. The intent of this investigation was to provide initial guidance on test variables and the control limits needed to implement the OBSI procedure. This chapter summarizes the evaluation and results of the test parameter investigation and makes recommendations on parameter limits and controls (additional information on the measurement sites and protocol, along with a more detailed explanation of the results of this analysis, are provided in Appendix C).

Description of Field Measurements

Parameters Evaluated

Measurements were conducted to evaluate vehicle variables and test execution variables on OBSI measurement results. The test matrix is shown in Table 2.

Environmental variables, such as air and pavement temperatures, wind conditions, and moisture conditions, could not be systematically controlled for these tests. However, temperature and wind conditions were measured throughout, and testing conducted over the extremes encountered was evaluated. All testing was conducted under dry conditions. Vehicle variables, including loading, tire inflation pressure, and vehicle-to-vehicle variation, were evaluated systematically. Because of the time period of the testing, longer term variables

of tire wear and hardness were not evaluated and wheel alignment was not evaluated except as it occurred from test vehicle to test vehicle. Test execution variables including probe location, run-to-run and day-to-day repeatability, probe configuration, small variations in test speed, and reproducibility were also measured. Reproducibility across multiple users was not assessed.

Measurement Sites

The initial portion of this testing was conducted at Minnesota DOT's MnROAD Low Volume Road facility in Albertville, MN. This facility is a 2.5-mile closed loop that contains 20 pavement test sections. Two of these sections, a fine textured AC and a random transversely tined PCC, were selected as test surfaces. Due to an extended period of rain, testing was limited to the SRTT tire and only a portion of the test matrix was completed. The remainder of the testing was conducted at the General Motors Desert Proving Ground (DPG) in Mesa, AZ, on relatively smooth AC and exposed aggregate PCC test sections. The site location, photographs of the pavement sections, and the average $\frac{1}{3}$ octave band spectrum for each surface under baseline conditions are provided in Appendix C.

Measurement Protocol

The baseline test condition for each test pavement and test tire followed the measurement protocol presented in Attachment 1 using "full-sized" rental vehicles along with a baseline load consisting of two people and the OBSI instrumentation. A photograph of the OBSI equipment installed on a test vehicle is shown in Figure 8.

Ideally, the same test vehicle would have been used as the baseline for all of the test scenarios. However, due to the relocation of the second portion of the testing, two different baseline vehicles were used. The test vehicle used at MnROAD

Table 2. Test parameter matrix.

Parameter	Variable Values	Tire
Repeatability (run-to-run)	10 consecutive runs	SRTT, Dunlop
Repeatability (day)	Nominal conditions each day	SRTT, Dunlop
Probe configuration	Single probe, dual probe	SRTT
Probe location, vertical	$\pm 1/4$ ", $\pm 1/2$ " vertical	SRTT, Dunlop
Probe location, fore/aft	$\pm 1/2$ ", ± 1 " fore/aft	SRTT, Dunlop
Probe location, from tire	$\pm 1/2$ ", -1 " from tire	SRTT, Dunlop
Test speed	± 2 , ± 4 mph	SRTT, Dunlop
Inflation pressure	± 4 , ± 8 psi	SRTT, Dunlop
Load	+100, +200 lbs	SRTT, Dunlop
Test vehicle	4 vehicles	SRTT, Dunlop

was a 2007 Buick Lacrosse CX. At the GM DPG, a 2007 Pontiac Grand Prix was used as the primary (baseline) test vehicle. The baseline tire was the Michelin/Uniroyal SRTT, with the Dunlop SP Winter Sport M3 tire (Dunlop) used in those conditions where tire-specific results are suspected to occur due to tread pattern differences. Photographs of the two test tires were provided in Chapter 3.

Measurements were conducted using the two-probe approach (15) at a baseline test speed of 60 mph and a "cold" tire inflation pressure of 30 psi. For the baseline condition, the probe was positioned 3 in. from the pavement surface and 4 in. from the face of the tire, at locations opposite the leading and trailing contact patch of the tire, and oriented so that the sensitive axis was positioned toward the tire. For evaluating the effects of temperature, testing was not restricted to a specific temperature range.

Three vehicle passes were made for each test parameter, which were averaged together during post analysis. A series of repeat baseline configuration measurements was performed at the completion of each set of tests for each parameter. In addition to the repeat baselines, 10 or more consecutive baseline passes were measured for each test tire to examine the run-to-run repeatability under the baseline configuration. These consecutive baseline measurements were assessed individually to examine the run-to-run repeatability under opti-

**Figure 8. OBSI equipment installed on DPG test vehicle.**

mal conditions. To evaluate the variations in OBSI levels attributable to the testing parameters, each 3-pass set of parameter measurements was compared to the 3-run sets of baseline measurements performed at the start and completion of each series of tests for each parameter.

The microphone signals were acquired with a five channel commercial analog to digital converter, which also powered the microphones and provided signal conditioning. This unit was interfaced to a laptop computer that used commercial software to produce first Fourier transform (FFT) narrow band and $1/3$ octave band sound pressure and sound intensity levels using a 5-second averaging time. The microphones were calibrated using a Class I precision acoustic calibrator set for 94 dB at the beginning and end of the measurement period. OBSI quality metrics of coherence between the two microphones comprising each probe and the difference between sound pressure and sound intensity level were monitored during data acquisition. The actual time signals of the four microphones were also monitored in order to identify any data acquisition abnormalities.

Meteorological Conditions

Noise measurements at the MnROAD facility were conducted on August 17, 2007, from 8:00 am until 8:15 pm. Air temperatures ranged from about 60°F at 8:00 am to a high of about 74°F at 2:00 pm and down to 66°F by 8:00 pm. The sky was clear during the early part of the testing period and then became overcast in the late afternoon into the evening.

Over the four days of testing at the GM DPG (September 10–13, 2007) clear skies prevailed and air temperature ranged from 86°F to 107°F. Easterly winds of up to about 18 mph were present on September 11th and 12th, parallel to the orientation of the test sections, resulting in almost no crosswind.

Results of Parameter Investigation

Run-to-Run Repeatability of Baseline Condition

At the beginning of the testing for each tire, ten or more consecutive passes were measured to examine the run-to-run repeatability under the baseline configuration. The tests were conducted using the SRTT tire at MnROAD and the Dunlop tire at the DPG. Testing for the SRTT runs occurred over a period of about 50 min, with an air temperature varying no more than 2°F. The Dunlop measurements were made over a period of about 25 min, with air temperatures varying no more than 2°F. A summary of the total range (difference between maximum and minimum for all runs) in overall A-weighted sound intensity levels and $1/3$ octave bands for the consecutive baseline runs is shown in Table 3 along with the standard deviation.

Table 3. Variation in OBSI levels for consecutive baseline runs.

	SRTT - AC		SRTT - PCC		Dunlop - AC		Dunlop - PCC	
	A-Wtd	1/3 Oct.	A-Wtd	1/3 Oct.	A-Wtd	1/3 Oct.	A-Wtd	1/3 Oct.
Range, dB	0.8	0.5 to 2.5	0.8	0.7 to 1.8	0.6	0.5 to 1.2	0.7	0.6 to 2.0
Std Dev, dB	0.3	0.2 to 0.9	0.3	0.2 to 0.6	0.1	0.1 to 0.3	0.2	0.2 to 0.6

The total range in overall A-weighted OBSI levels for the consecutive baseline runs was 0.8 dB for the SRTT tire on both the AC and PCC pavements. For the Dunlop tire, the range in level was 0.6 and 0.7 dB for the AC and PCC pavements, respectively. The baseline runs for this portion of the analysis were made consecutively and no changes in the fixture configuration or measurement protocol were made between runs. As a result, the difference measured for the consecutive baselines can be considered to be measurement uncertainty. Where OBSI levels under different parameter values fall within the standard deviation of the consecutive baselines, the changes in noise level cannot be reasonably attributed to changes in the given parameter because of this uncertainty.

Test Tire (SRTT versus Dunlop)

Data obtained using the SRTT and the Dunlop tires were examined using the baseline measurement results from the DPG, where both test tires were assessed on the same set of pavements. Because baseline measurements were conducted

for each test tire over a period of several days, some variation in the baseline levels occurred because of temperature variations (discussed under Environmental Variables). To more readily examine the differences in noise between the two test tires, baseline measurements were averaged for each tire on both the AC and PCC pavements. The Dunlop tire baseline measurements conducted prior to 8:30 am were not included because similar early morning measurements were not conducted with the SRTT. The Dunlop tire resulted in overall sound intensity levels that were 2.2 and 1.9 dB higher than the SRTT levels for the AC and PCC pavements, respectively, with an average difference of 2.0 dB. Higher 1/3 octave band levels occurred with the Dunlop tire for all frequencies except the 2,000 and 2,500 Hz bands, where levels with both tires were similar. The average 1/3 octave band spectrums for each surface at the DPG facility under baseline conditions for both tires are shown in Figure 9.

The differences in these measurements were somewhat lower than those measured previously for Test Sites S1, S4, S5, W5, and Waverly which ranged from 2.3 to 3.0 dB, with the

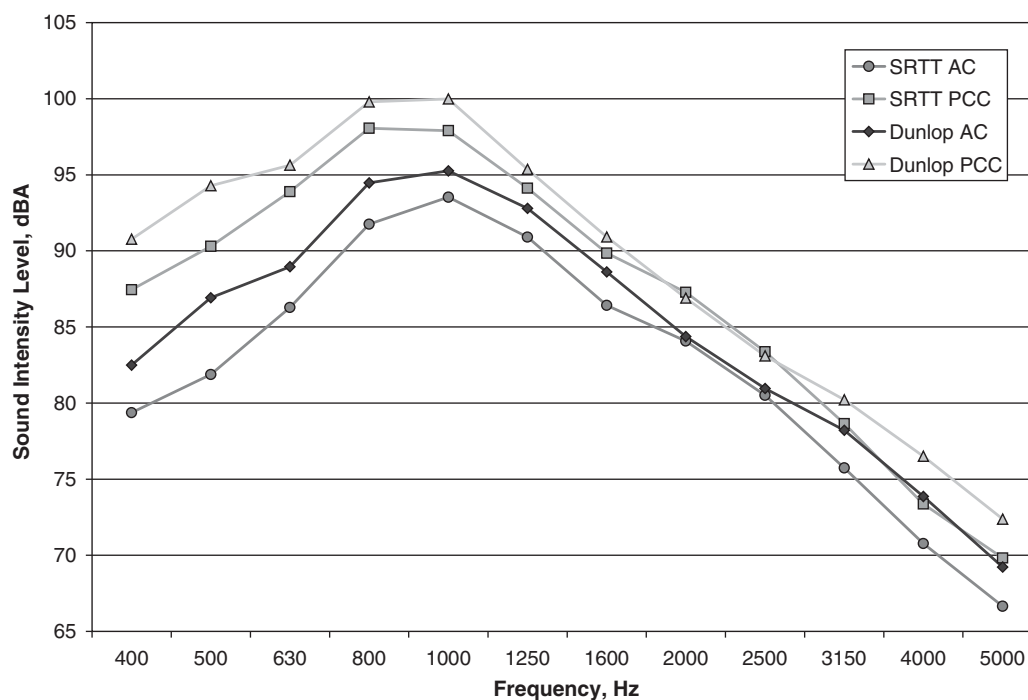
**Figure 9. 1/3 Octave band OBSI levels for SRTT and Dunlop tires.**

Dunlop producing higher levels than the SRTT. They were, however, similar to the differences found for the passby sites (see Chapter 5), which ranged from 0.9 dB to 3.1 dB with an average difference of 2.0 dB.

Environmental Variables

Three-run series of baseline configuration measurements were performed at the completion of each set of tests for each parameter. Over the day of testing at MnROAD, air temperature ranged from about 66.2°F to 74.3°F for the baseline configurations and pavement temperature varied from 79.9°F to 107.2°F for the AC pavement and from 78.1°F to 98.6°F for the PCC pavement. The temperature fluctuation throughout the day in Mesa was greater than that in Minnesota and, unlike the MnROADs testing, the baselines at the DPG were acquired over multiple days. During baseline measurement runs at the DPG site, the air temperature ranged from about 99.0°F to 102.9°F and pavement temperature varied from 99.0°F to 141.8°F for the AC pavement and from 95.4°F to 131.4°F for the PCC pavement over the four-day testing period. The relationship between overall A-weighted OBSI levels and the measured air temperatures are plotted in Figure 10 for the SRTT and Dunlop test tires on both DPG AC and PCC pavements, along with a linear regression for each data set.

The data indicated no clear correlation between the SRTT and air/pavement temperature. A slight downward trend with an increase in air and pavement temperature was found, but r^2 values were very low (0.0 to 0.4). In addition, the range in overall levels for the SRTT tire was only slightly higher than the standard deviation of the consecutive baselines: 0.5 and 0.3 dB for the AC pavements, and 0.6 and 0.5 dB for the PCC pavements at MnROAD and the DPG, respectively. For the Dun-

lop tire at the DPG, the ranges in level between baselines were 1.1 and 1.0 dB for the AC and PCC pavements, respectively, with the levels showing a decreasing trend with an increase in temperature. The results indicate a decrease of 1 dB in the overall OBSI level measured with the Dunlop tire with an air temperature increase of about 18°F. This corresponds to 1 dB decrease in level for a 48.6°F increase in pavement temperature. For the data of Figure 10, the r^2 values for noise-to-temperature regressions for the Dunlop tire were 0.76 and 0.82. The spectra for temperature changes increased or decreased with temperature in a uniform manner.

Systematic Vehicle and Test Execution Variables

Measurement parameters including probe location in the vertical and fore/aft directions, probe distance from tire sidewall, vehicle test speed, vehicle loading, and tire inflation pressure were evaluated incrementally for both the SRTT and Dunlop tires. Three-run sets of baseline repeats, as discussed for the evaluation of environmental variables, were conducted prior to and after each series of tests for each parameter. For some of the parameters, no difference in level within the established measurement uncertainty could be determined. The most sensitive parameters were found to be variation of probe location in the vertical direction, vehicle speed, tire inflation pressure, and vehicle loading, as summarized in Table 4 for the range of parameter values defined in Table 2.

The trends noted in Table 4 only apply within the range of the parameter variations measured in this testing. Given the limited number of data points for each parameter, only linear relationships were considered. The range of slopes reported for any one parameter reflects the range found for

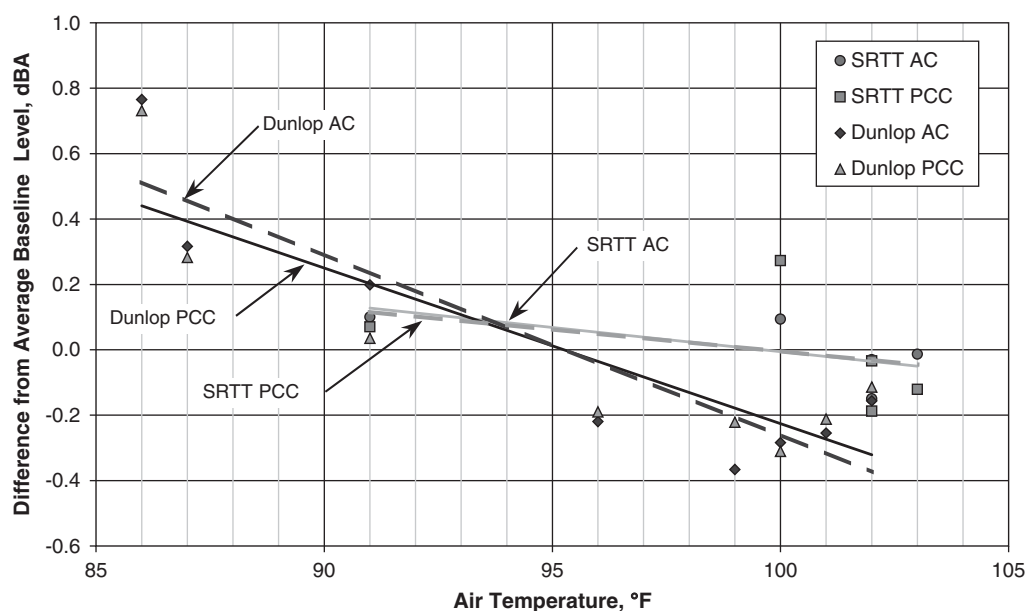

Figure 10. OBSI level versus air temperature for DPG pavement sections.

Table 4. Linear relationships between test parameters and OBSI levels.

Parameter	Linear Regression Slopes
Probe Location, Vertical	-0.3 to -0.4 dB per ¼" upward movement
Vehicle Test Speed	+0.2 to +0.3 dB per 1 mph increase
Tire Inflation Pressure	Frequency shift, see explanation below
Vehicle Load	+0.1 to +0.4 dB per 100 lb increase

specific tires and pavement (complete results are provided in Appendix C). There was a consistent downward trend in noise levels as the probe location was moved incrementally from ¼ in. below to ½ in. above the standard probe location in the vertical direction (about 0.4 dB decrease in noise levels per ¼ in. of movement). For vehicle test speed, OBSI noise levels increased with speed (by about 0.3 dB per 1 mph). Similarly, noise levels increased with an increase in the vehicle load (0.2 to 0.4 dB increase per 100 lb load increase). For probe location in the vertical direction and vehicle test speed, similar trends were indicated over both the AC and PCC pavements for both the SRTT and Dunlop test tires and the spectral characteristics of each pavement were maintained. Vehicle loading resulted in slightly lower increases on the AC pavement (and SRTT tire) than on the PCC pavement (and Dunlop tire); there was a 0.2 dB increase per 100 lbs load for the AC pavement, as compared to 0.3 and 0.4 dB increases for the PCC pavement. The loading-related increases occurred primarily in the frequencies below 1,000 Hz, although a small increase in the mid to high frequencies occurred on the AC section.

As tire inflation pressure increases, ⅓ octave band levels below 1,000 Hz decrease and levels above 1,000 Hz increase,

resulting in small overall changes to the sound intensity level (0 to 0.5 dB increase per 10 psi increase) as shown in Figure 11. These changes are within the repeat baseline variability. However, the frequency shifts are notable; a 2.4 dB increase per 10 psi increase was indicated in the 1,250 Hz band for both pavements; shifts in the other frequency bands were smaller.

The data did not indicate a clear correlation between OBSI levels and probe location in the fore/aft directions. A small downward trend in noise levels occurred as the probe location was moved further from the tire sidewall (about 0.2 dB per ½ in. of movement). The changes in noise level due to variation of the probe distance from the tire sidewall are generally within the standard deviation for the consecutive baselines and slight variation of these parameters in the testing configuration is not anticipated to affect the OBSI result (assuming testing is conducted following the standard protocol). The spectral characteristics of each pavement were maintained.

Test Vehicle

At the GM DPG, a 2007 Pontiac Grand Prix was used as the primary (baseline) test vehicle and results were compared to three other vehicles, including a second 2007 Pontiac Grand Prix, a 2007 Chevrolet Impala, and a 2007 Buick Lacrosse. The same measurement system and tires were used for all vehicles. For the SRTT tire, the overall levels varied by up to 0.6 dB for the AC pavement and by up to 0.8 dB for the PCC pavement. For the Dunlop tire, the overall levels varied by up to 1.2 dB for both the AC and PCC pavements. Although the differences in level between test vehicles exceeded the standard deviation for the consecutive baseline runs, the variability of

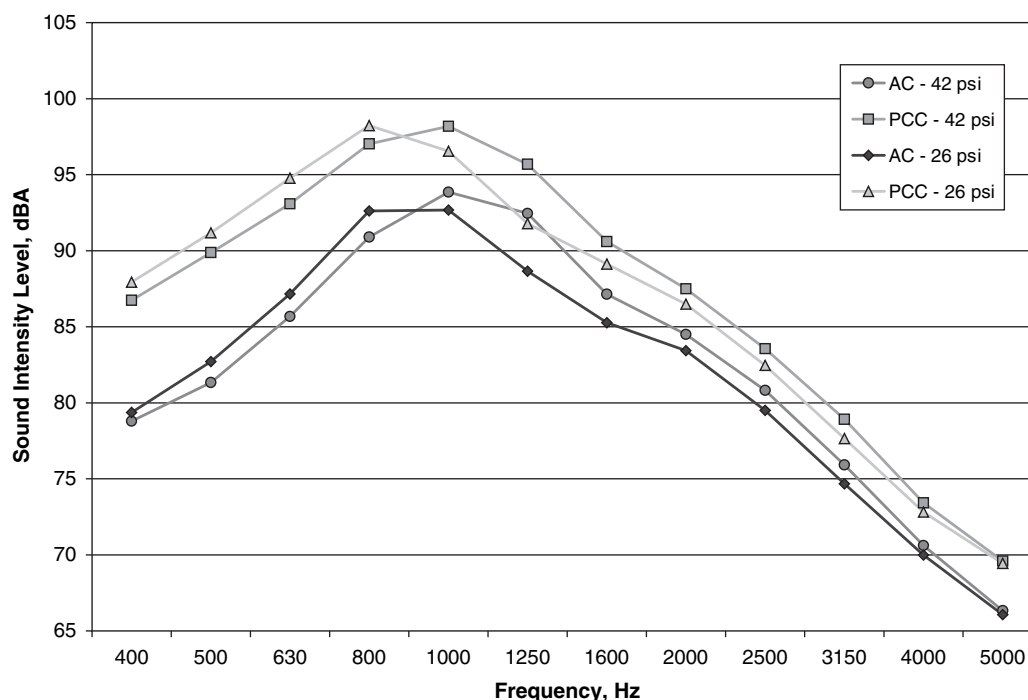

Figure 11. ⅓ Octave band levels at various tire inflation pressures, SRTT test tire.

the environmental conditions was also considerably higher for these runs. The differences between vehicle results can be attributed to differences in temperature (discussed in this chapter under Environmental Variables), which were more apparent with the Dunlop tire. A considerable amount of time was required to change tires and vehicles between measurement sets, resulting in notable air and pavement temperature differences between vehicle sets. Measurements conducted during the morning period (prior to 9:30 am), when temperatures were 10.8°F to 12.6°F lower than during the late morning and afternoon, resulted in the highest levels. The tests conducted during midday (between 11:00 am and 4:00 pm) using three vehicles yielded results within 0.5 dBA for both the SRTT and Dunlop tires and similar spectral characteristics. Although the test vehicle variation did not produce substantial differences in OBSI levels, the same vehicle family, measurement system, and tires were used. Differences resulting from a wider range of vehicle types, OBSI measurement equipment, and multiple test tires of the designs, were not evaluated.

Fixture Configuration (Single Probe versus Dual Probe)

Single versus dual probe configurations were examined using the SRTT tire at the GM DPG site (photographs of the probe configurations are included in Appendix C). The comparison of the probe configurations was made for test speeds of 45 and 60 mph. At 45 mph, the dual probe produced levels that were 0.1 dB to 0.5 dB lower for both pavements, while at 60 mph, the dual probe levels were 0.1 to 1.0 dB lower. These typically small and varied differences in level are consistent with those reported previously (14). The spectral shapes for both probes were very similar throughout the measured frequency range.

Data Quality Criteria

During the data acquisition, the coherence between the signals from the two microphones comprising each probe and the difference between sound pressure and sound intensity level (PI Index) were monitored and recorded for each 1/3 octave band. Coherence is a measure of the linear dependency of two signals with a value of 0 being no dependency, and a value of 1 being perfect linear dependence (16). Mathematically, it is the magnitude of the cross-spectrum between two signals squared divided the product of the auto-spectrum of both signals. For sound intensity measurements made in flow such the OBSI measurements, it is generally found that the data are contaminated with flow noise when the coherence falls below 0.8 (15). With only a few exceptions, the coherence was greater than 0.8 in all 1/3 octave bands from 400 to 4,000 Hz during the parameter measurements. In the 400 and 4,000 Hz bands,

Table 5. Recommended parameter limits.

Parameter	Recommended Criteria (Limit)
Run to Run Repeatability, Overall A-Wtd OBSI level	Within 1 dB
Run to Run Repeatability, 1/3 Octave Band Levels	Within 2 dB
Probe Location, Vertical	3 ± 1/4" above pavement
Vehicle Test speed	60 ± 1 mph
Tire Inflation Pressure (Cold)	30 ± 2 psi
Vehicle Load	± 100 lbs
Probe Location, Fore/Aft	Leading/Trailing edge ± 1/2"
Probe Distance from Tire Sidewall	4 ± 1/2"
Coherence	> 0.8 for frequencies below 4,000 Hz
PI Index	< 5 dB for data reported as valid

slight decreases in coherence occurred at the DPG site in 4 out of 578 runs when high temperatures caused equipment overloads and overheating (these data were discarded). Above 4,000 Hz, coherence is typically lower due to limitations in the finite difference approximation used in the algorithm for determining sound intensity (15). At the 5,000 Hz band, coherence was less than 0.8 for 38% of the parameter runs. The PI index is also used as a data quality check. Generally, if the PI index is above 5 dB, the measurement is contaminated by flow noise (14). In the parameter testing, the PI index was less than 5 dB in all 1/3 octave bands from 500 to 5,000 Hz. PI index values for the trailing edge position occasionally exceeded 5 dB in the 400 Hz band (about 3% of the runs). Because the levels in the 400 Hz 1/3 octave band were sufficiently low so as to have minimal effect on the overall level, the 400 Hz band was not included if the PI index exceeded 5 dB.

Recommendations on Parameter Limits

Based on the results of this research, parameter limits listed in Table 5 for the run-to-run variation, variation of probe location in the vertical direction, vehicle speed, tire inflation pressure, and vehicle loading are recommended. Reasonable variations in some of the testing parameters including location of the probe in the fore/aft direction and probe distance from the tire sidewall would not be anticipated to adversely affect the OBSI results. Parameter limits on these less sensitive variables and on the data quality criteria are based on the results of this study, as well as general experience in conducting these field measurements.

Sufficient data on the effects of environmental variables on OBSI levels are not available to set limits at this time. Measurement, monitoring, and documentation of air temperature, pavement temperature, wind speed and direction, and pavement dampness, as indicated in the standard protocol, may help researchers to establish these variables in time over a larger data set.

CHAPTER 5

Demonstration Testing of OBSI Procedure

Introduction

The investigation was conducted to demonstrate the ability of the OBSI measurement method to quantify the relative effect of different pavement types in comparison to total vehicle noise emissions measured with the CPB and SPB methods. It included the simultaneous measurement of (1) OBSI on specific candidate test tires, (2) controlled passbys on test vehicles equipped with the test tires, and (3) statistical passbys of both light- and heavy-duty vehicles on in-service pavements. Using the SPB data, the relationship between OBSI tire-pavement noise and average vehicle noise emissions was examined for both light vehicles and heavy trucks. To account for site-to-site variation, passby results were normalized using the measured relationships between OBSI and CPB levels for each site. This chapter describes the measurements performed, the results of the OBSI and passby testing, and the relationships between the OBSI and passby data.

Description of Field Measurements

Measurement Sites

The OBSI and passby testing was conducted at a total of 12 sites (five in Iowa and seven in California). The sites in Iowa were located along U.S. Highway 30 between mileposts 178 and 198, near Marshalltown. Portions of this section of highway were recently constructed to include many different types of surface texturing (17). Along this section of highway, four sections with different PCC texture were selected as test sites, including a burlap drag surface, a random transverse tined surface, a uniformly tined surface, and a longitudinally tined surface. In addition, a nearby hot-mix AC pavement section was selected as a test site. In California, four of the Caltrans test sections on LA 138 (18), including DGAC, OGAC, rubberized, and bonded wearing course AC pavements were tested. Two PCC sections, a grooved and a ground pavement, on the Caltrans research sites on the Mojave Bypass (KN 58) (19)

were also tested. In addition, a highly porous rubberized AC pavement along Shasta 299, about 5 miles east of Redding was tested. The site location, photographs of the pavement sections, and the average $\frac{1}{3}$ octave band spectrum for each surface under baseline conditions are provided in Appendix D.

All test sites followed the applicable criteria stipulated in the FHWA document on highway noise measurement (20) and the ISO 11819-1 procedure (21). To the degree reasonable, sites were selected to have acoustically hard (non-sound absorbing) surface characteristics between the vehicle lane of travel and at least half of the distance to the 25-ft microphone following the ISO recommendation. Because the ISO procedure only addresses 25-ft distances, the FHWA criteria were used for the 50-ft microphone positions. To obtain comparable results, sites were selected along roadways where the posted and typical vehicle speeds were 55 mph or higher. The designation, location, and description of each of the test sites are listed in Table 6 (details of these sites are also provided in Appendix D).

Measurement Protocol

OBSI and controlled passby measurements were conducted using the 2007 Pontiac Grand Prix and the 2007 Chevrolet Impala with Michelin/Uniroyal SRTT and Dunlop SP Winter Sport M3 tires (Dunlop). The OBSI measurements followed the measurement protocol discussed for the parameter investigation using the two-probe approach (2) with a vehicle load consisting of two people and the OBSI instrumentation. Measurements were conducted at 60 mph and at test speeds varying from 50 to 70 mph, in 5-mph increments, depending on the typical speed of on-road vehicles, in order to match the speeds of the SPB measurements. The microphone signals were acquired using the same instrumentation and data analysis system described in Chapter 4. A standard 5-second averaging time was used for test Sites 1 through 9 and 12; a 4-second averaging time was used for Sites 10 and 11 because of the shorter lengths of pavement sections. During post-analysis,

Table 6. Passby test sites.

Site #	Location	Description
1	US 30 near Marshalltown, IA	PCC-Burlap Drag
2	US 30 near Marshalltown, IA	PCC-Random Transverse Tine
3	US 30 near Marshalltown, IA	PCC-Uniform Transverse Tine
4	US 30 near Marshalltown, IA	AC-Dense Graded
5	US 30 near Marshalltown, IA	PCC-Longitudinal Tine
6	LA 138 near Lancaster, CA	AC-Dense Graded Overlay
7	LA 138 near Lancaster, CA	AC-Open Graded Overlay
8	LA 138 near Lancaster, CA	AC-Rubberized Open Graded Overlay
9	LA 138 near Lancaster, CA	AC-Bonded Wearing Course
10	KN 58 near Mojave, CA	PCC-Grooved on Burlap Drag
11	KN 58 near Mojave, CA	PCC-Ground (2.67 Blade Spacing)
12	Shasta 299 near Redding, CA	AC-Rubberized Open Graded Overlay

the 60 mph samples were reanalyzed into shorter sample segments to assess the variation of OBSI level over the standard 440-ft test section. The microphones were calibrated at the beginning and end of the measurement period. Three passes were made for each test speed, which were averaged together during post analysis. During the data acquisition, OBSI quality metrics of coherence between the two microphones comprising each probe and the difference between sound pressure and sound intensity level were monitored. The actual time signals of the four microphones were monitored in order to identify any data acquisition abnormalities.

Statistical vehicle passby measurements were done generally following the procedures described in the report “Measurement of Highway-Related Noise” (20). Two microphone positions were used: one at a distance of 25 ft from the centerline of travel and one at a distance of 50 ft at heights of 5 ft above the height of the pavement. An example passby measurement setup is shown in Figure 12 for the longitudinally tined PCC pavement (Site 5). The passby sound pressure levels were measured using two-channel real time analyzers (RTA). The analyzers were set to “fast” response ($\frac{1}{8}$ second exponential average) and the $\frac{1}{3}$ octave band and overall A-weighted sound pressure levels occurring in $\frac{1}{10}$ th-second intervals were logged during the passby. The maximum level for each passby was then determined from a plot of sound level versus time

**Figure 12. Typical passby measurement setup.**

provided from the RTA. The microphone output signals were also captured on a solid-state digital recorder as backup and later use as required. Vehicle speed and type (light vehicle, medium or heavy duty truck, or “other”) were manually recorded for each measured passby. Vehicle speed was measured with a radar gun and wind speed was documented from an anemometer at regular intervals. Prior to testing, the test vehicle speedometer was calibrated with the radar gun “shot” in a direction very nearly parallel to the centerline of vehicle travel. Vehicle speed measurements during the CPB tests were later used to adjust the recorded speed to the actual speed at the measurement angle used for passby data collection. The total number of passby events acquired at each site ranged between 178 and 259 depending on the occurrence of sufficient (nominally 40) heavy truck passby events.

Controlled vehicle passby measurements of the test vehicles followed the same procedures as those described for the statistical passbys. A minimum of three passbys was measured at each test speed.

Meteorological Conditions

Testing in Iowa (Sites 1 through 5) was conducted over a 3-day period from September 26th to 28th, 2007, where clear skies and calm to light winds (0 to 7 mph) prevailed. Temperatures ranged from 48 to 60°F for the morning testing on the 26th and 28th, from 60 to 68°F on the afternoon of the 26th, from 59 to 73°F on the morning of the 27th, and from 76 to 77°F on the afternoon of the 27th.

Measurements along LA 138 (Sites 6 through 9) and Mojave Bypass (Sites 10 and 11) were conducted on November 6th to 9th, 2007. The sky was clear during the testing with winds from the east of up to 9 mph. Air temperatures ranged from about 60°F in the morning to highs of about 75 to 77°F in the afternoon on all 4 days. The Shasta 299 (Site 12) monitoring was conducted on November 30, 2007, where clear skies and air temperatures ranging from 45°F to about 55°F, with winds speeds of up to 6.7 mph prevailed.

Data Reduction and Analysis

Data Reduction

To produce tire OBSI levels for each run, the leading and trailing edge levels were averaged together on an energy basis. For each condition (vehicle speed, pavement, and tire), the $\frac{1}{2}$ octave band levels between 250 and 5,000 Hz for the three runs were arithmetically averaged to represent that condition. The overall level between 400 and 5,000 Hz was then calculated. Although the levels in the 400 Hz band were sufficiently low so as to have minimal effect on the overall level, they were included as data quality indicator requirements were met. These overall levels were then used for comparison to the overall passby levels. The 60-mph samples were also reanalyzed into shorter sample segments to assess the variation of OBSI level over the standard 440-ft test section (results are provided in Appendix D). Most of the sections exhibited fairly homogeneous noise levels throughout the length of the test section. Two of the pavement sections, Site 2 and Site 12, showed notable variation. Based on the review of several passes over the same pavement section, the level variation occurred in the same locations as the vehicle traveled over the pavement. It was determined that the 4- and 5-second average levels for each site were appropriate for the remainder of the OBSI/passby analysis.

In processing the passby data, each event for both the 25-ft and 50-ft microphone positions was reviewed to verify that it was acoustically “clean.” The ISO 11819-1 (21) criteria was used to define clean passby events; only events where a single peak rose at least 6 dB above any surrounding data were included in the analysis. The maximum level for each such event was paired with the recorded vehicle type and speed. For the SPB events, these levels were plotted against vehicle speed for both light vehicles and heavy trucks. The data were then fit with a standard

logarithmic regression producing an equation and r^2 value and plots were reviewed for “outlier” points (points seemingly outside the normal range of data). Points that could be associated with field notes of unusual noises were dropped from the data set. For each data set, the usable speed range was also determined. The clean passby vehicle counts and speed ranges for the test sites are given in Table 7. For comparison to OBSI and CPB data, the logarithmic regression equations for each data set were used to calculate the average SPB level for usable speed range in 5-mph steps (plots of the SPB data and the regression curves, equations, and r^2 values are given in Appendix D).

The data from the CPB events were processed similar to the SPB data. However, the data for the passby levels were processed in 5-mph increments over the speed range within 50 to 70 mph. Average levels at each speed, site, and tire configurations were calculated and used in comparison to the OBSI and SPB data. An example of SPB and CPB levels versus speed is shown in Figure 13 for Site 5, the longitudinally tined PCC pavement on U.S. 30 (similar plots for all of the test sites are included in Appendix D).

Data Analysis

Once the overall SPB, CPB, and OBSI levels were established, data analysis was performed to investigate specific aspects of the results. For the light vehicle overall levels, cross-plots of CPB versus OBSI, SPB versus OBSI, and SPB versus CPB were constructed for both test tires and for each microphone distance. These included levels for all speeds and all sites. For the heavy truck overall levels, plots of SPB versus OBSI and SPB versus CPB were constructed. For each cross-plot, the data were fit with linear regressions and best fit 1-to-1 slope lines. From these, the slope of the linear regression and r^2 values were

Table 7. Number of clean SPB events and vehicle speed range at each test site.

Site #	Light Vehicles				Heavy Trucks			
	25 ft Microphone Distance		50 ft Microphone Distance		25 ft Microphone Distance		50 ft Microphone Distance	
	# of Events	Speed Range (mph)	# of Events	Speed Range (mph)	# of Events	Speed Range (mph)	# of Events	Speed Range (mph)
1	103	55–70	44	55–70	30	60–70	15	60–70
2	136	50–70	129	50–70	31	50–65	31	50–65
3	120	55–70	120	55–70	42	60–65	42	60–70
4	37	55–65			14	55–65		
5	123	55–70	118	55–70	56	60–70	54	60–70
6	123	50–70	123	50–70	54	50–65	54	50–65
7	123	50–70	123	50–70	56	50–65	56	50–65
8	108	50–70	108	50–70	49	50–65	49	50–65
9	89	50–70	89	50–70	42	50–65	42	55–65
10	136	60–70	135	60–70	80	50–65	80	50–65
11	119	60–70	118	60–70	52	50–70	52	55–70
12	126	50–70	119	50–70	33	50–65	33	50–65

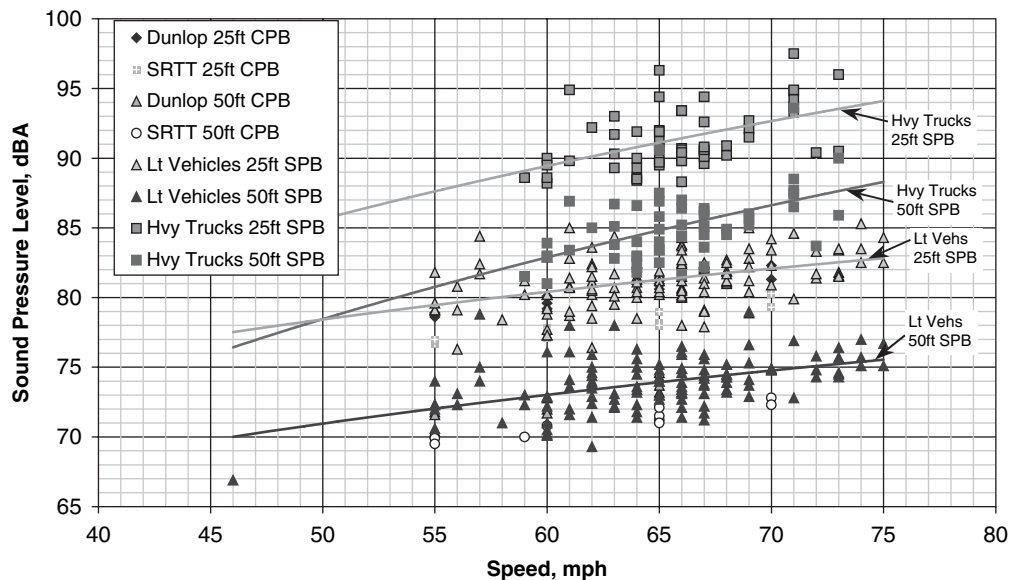

Figure 13. SPB and CPB levels versus speed for heavy and light vehicles at 25 and 50 ft for Site 5 (longitudinally tined PCC pavement).

determined as was the offset, standard deviation, and average deviation from the 1-to-1 line resulting in data similar to that shown in Table 1. Additionally, the difference between OBSI and CPB levels was calculated for each site, each speed, and each tire for those cases where the corresponding data or both types were available (for the 25-ft and 50-ft data). The average and deviations were also determined for these data. The difference between the 25-ft and 50-ft passby levels was also calculated for each passby event for which the corresponding data were available.

The differences between the OBSI and CPB data were used to develop normalization coefficients to account for site-to-site geometry and propagation differences. The need for site normalization has been noted in previous work (15). Earlier SPB studies on LA 138 reported site biases ranging from -0.6 to 1.4 dB relative to the reference site factors for both the 25-ft and 50-ft microphone locations (15). The measurements conducted in Phase I displayed site-specific effects of up to 4 dB even for measurement distances of 25 ft. These effects were evidenced both by propagation testing (see Appendix B) and corresponding differences between the OBSI and CPB. Due to the traffic volumes at the measurement sites, propagation tests could not be made. As a result, site normalization factors were determined by first determining the average difference between OBSI and CPB levels at each site and overall average for the 12 test sites. The average OBSI/CPB difference for each site was then subtracted from the average of all sites to determine the normalization factor for each site. These factors were then applied to the SPB data on a site-by-site basis, and back to the CPB data for confirmation. The normalization coefficients were also applied to the heavy-truck SPB data.

Results and Discussion

The primary results of these measurements are presented in this section (more complete results, including the remainder of the cross-plots, spectral comparisons of OBSI and CPB levels, and level versus speed plots for the CPB and SPB data are given in Appendix D).

Normalized SPB and CPB Data versus OBSI

In order to demonstrate the applicability of the OBSI data to in-service pavements, a series of cross-plots were considered in which the relationships between OBSI and the passby data could be quantified. The first step was to develop the normalized relationship between the CPB and OBSI data for all sites and speeds for each tire using the analysis discussed in the previous section. The effect of the normalization can be seen by comparing the raw cross-plots of CPB levels versus OBSI for the SRTT tire in Figure 14 to the normalized results shown in Figure 15.

In Figure 14, the data points from any one site tend to fall below or above the regression line and the 1-to-1 line. Ignoring these offsets, the points for each site tend to follow a constant slope similar to the regression and 1-to-1 lines. When the data are normalized as shown in Figure 15, these offsets collapse to follow a 1-to-1 slope with considerably less scatter. In this example, the slope of the regression is decreased from 1.31 to 1.06 and r^2 value is increased from 0.91 to 0.96 with normalization. The 1-to-1 offset remains virtually the same with normalization (24.2 dB with it and 24.3 dB without), however, the standard deviation about the line is reduced substantially from 1.4 to 0.6.

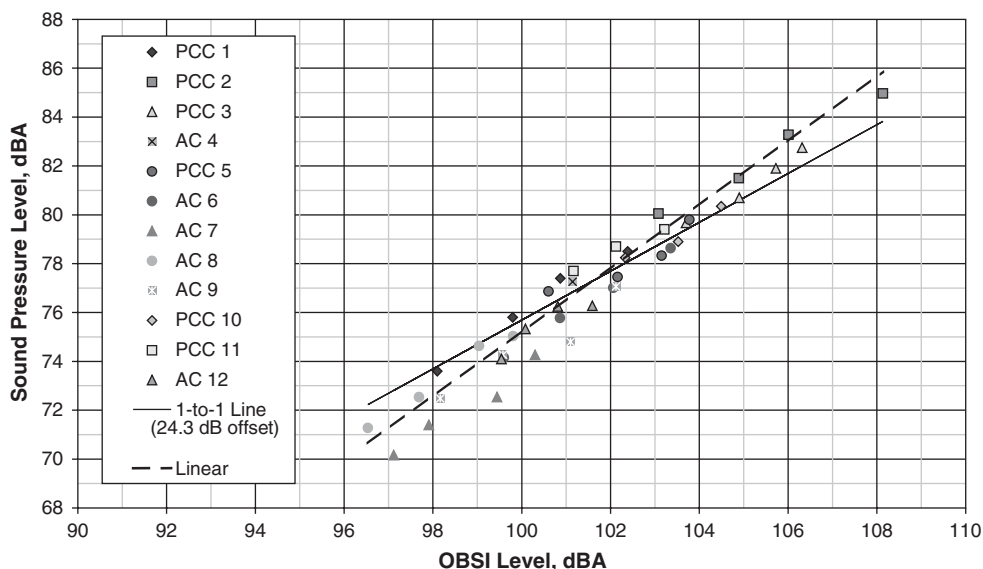

Figure 14. Controlled vehicle passby levels at 25 ft versus OBSI level for the SRTT at all test sites and speeds—raw data.

Normalization produced similar effects on the data from the Dunlop tire and both tires for the 50-ft microphone locations as indicated in Table 8.

In each case, the value of 1-to-1 offset remained virtually unchanged while the standard deviations are reduced by more than 50%. This finding confirms that the normalization does not affect the relationship between the CPB and OBSI data but it reduces the scatter attributed to site-to-site variation, and therefore, the coefficients were also applied to SPB data. Site normalization produced a similar effect on the SPB data as it did on the CPB data. Invariably, the value of the 1-to-1 line offset

was virtually unaffected while the scatter was reduced as shown in Figures 16 and 17 for the 25-ft, light vehicle SPB data and the SRTT OBSI data. The effect on the plot metrics for 50-ft data and the Dunlop tire are given in Table 9.

As noted in Table 9, the reduction in scatter for the SPB data is not as pronounced as it was for the CPB data (see Table 8) partially due to the appreciable scatter was seen between the CPB and SPB data as illustrated in Figure 18 for the SRTT data at 25 ft. In this plot, any site bias is effectively cancelled out leaving only the ability of the test tire to replicate the behavior of the SPB data that spans many different tires and other light vehicles.

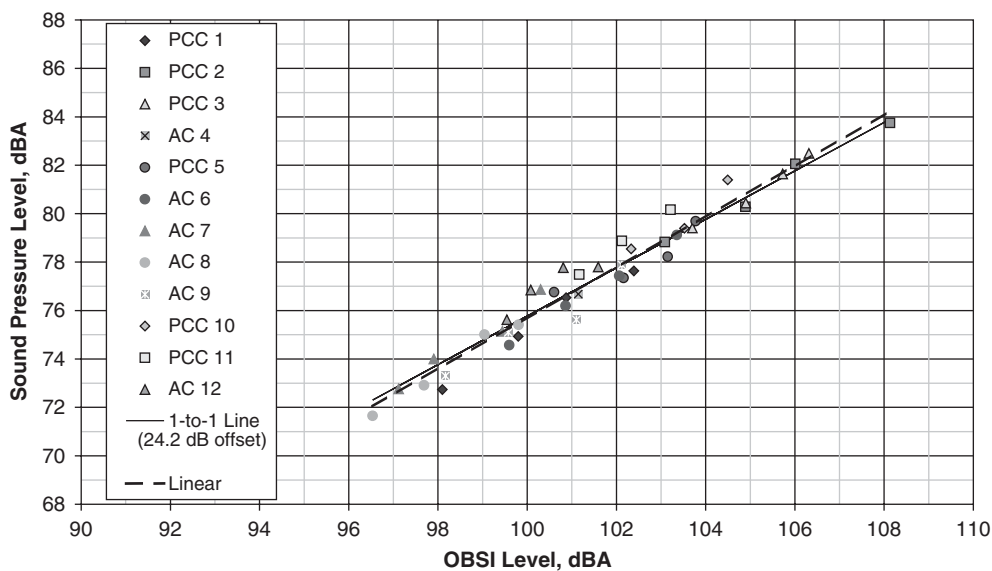

Figure 15. Controlled vehicle passby levels at 25 ft versus OBSI level for the SRTT at all test sites and speeds—normalized data.

Table 8. Metrics for CPB versus OBSI relationship.

Cross-Plot Metrics	25 ft Microphone Distance				50 ft Microphone Distance			
	SRTT		Dunlop		SRTT		Dunlop	
	Raw	Norm	Raw	Norm	Raw	Norm	Raw	Norm
Slope	1.31	1.06	1.17	0.95	1.41	0.97	1.38	0.97
r^2	0.91	0.96	0.85	0.94	0.86	0.96	0.86	0.96
Offset, dB	24.3	24.2	24.8	24.7	31.4	31.0	31.7	31.3
Std Dev, dB	1.4	0.6	1.4	0.6	1.9	0.6	2.0	0.5
Avg Dev, dB	1.1	0.6	1.1	0.5	1.6	0.4	1.6	0.4

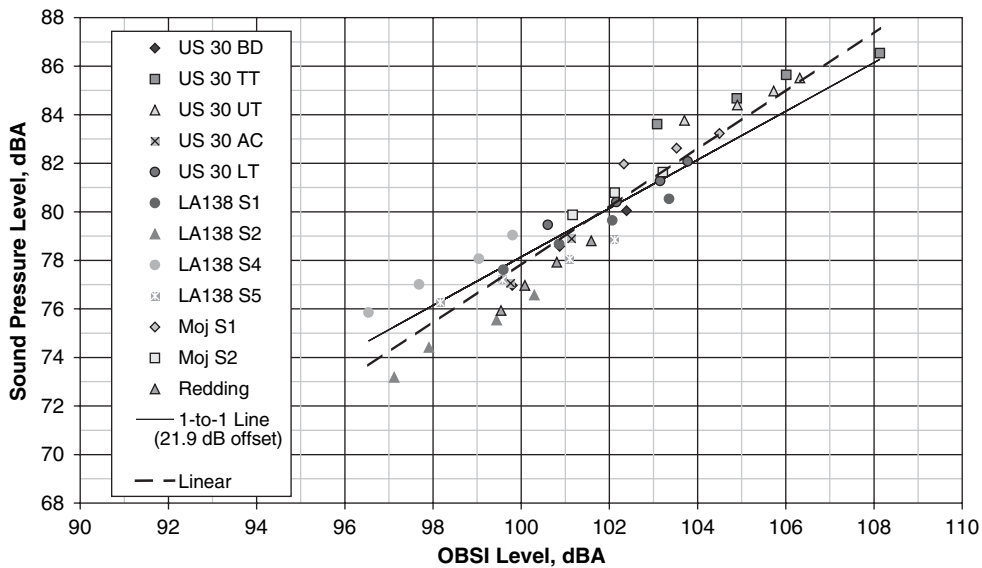

Figure 16. Statistical light vehicle passby levels at 25 ft versus OBSI level for the SRTT at all test sites and speeds—raw data.

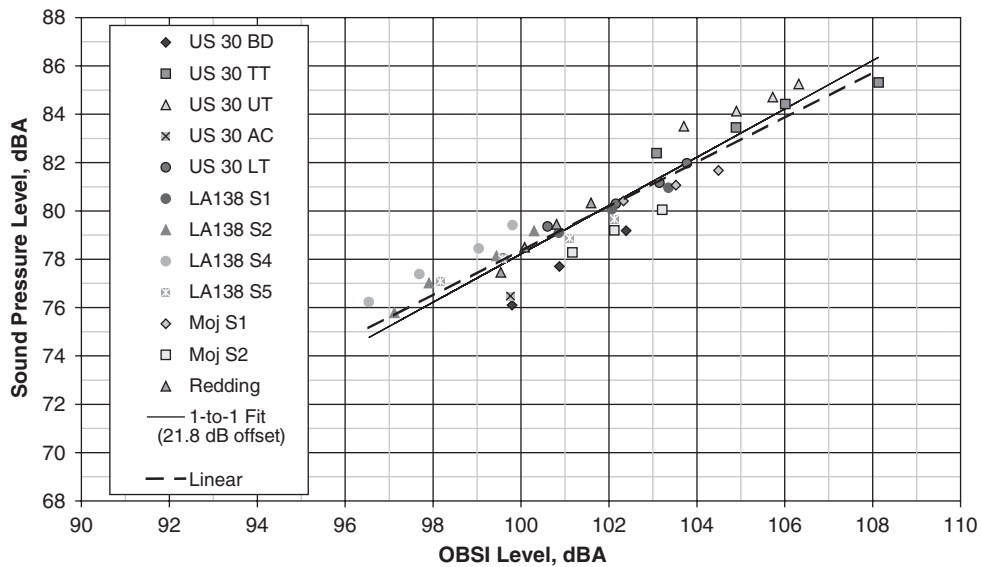

Figure 17. Statistical light vehicle passby levels at 25 ft versus OBSI level for the SRTT at all test sites and speeds—normalized data.

Table 9. Metrics for light vehicle SPB versus OBSI relationship.

Cross-Plot Metrics	25 ft Microphone Distance				50 ft Microphone Distance			
	SRTT		Dunlop		SRTT		Dunlop	
	Raw	Norm	Raw	Norm	Raw	Norm	Raw	Norm
Slope	1.31	0.92	1.29	0.93	1.32	0.91	1.32	0.91
r ²	0.95	0.88	0.89	0.87	0.84	0.87	0.84	0.89
Offset, dB	21.9	21.8	23.9	23.8	28.5	28.3	30.5	30.3
Std Dev, dB	1.2	0.9	1.4	0.9	1.7	0.9	1.9	0.9
Avg Dev, dB	1.2	0.8	1.2	0.7	1.5	0.7	1.7	0.6

The metrics for the SPB versus CPB cross-plots for the 25-ft and 50-ft and SRTT and Dunlop data are given in Table 10; the standard deviations range from 0.7 to 1.0. Since the relationship of the OBSI data to the SPB data is linked to the correlation of the CPB results to the SPB data, the scatter between the normalized SPB and OBSI data was similar to the scatter reported in Table 8 between the CPB and OBSI data.

In applying this approach to heavy trucks, the normalization coefficients developed for the light vehicles were applied directly in the SPB to OBSI comparison. Arguably, the effect of site-to-site variations may be different for trucks than light vehicles due to differences in effective source height. However, as with the light vehicles, normalizing the SPB data produced a reduction in the deviations about the 1-to-1 line with minimal change in offset for each microphone distance and test tire.

Cross-plots of the SPB versus OBSI data for the SRTT measured at 25 ft are shown in Figures 19 and 20 for the raw and normalized data, respectively.

The metrics for 50 ft and the Dunlop tire are shown in Table 11. Unlike the light vehicle data, normalizing the truck data did not result in the regression line slope more closely approaching 1. Instead, the slope decreases even more because

of the increase in the relative contributions from engine/exhaust noise as the speed decreases as noted in the Reference Energy Mean Emission Levels (REMELs) database (22). This would have the effect of causing higher overall levels at the lower speeds than levels due to tires alone resulting in a decreased slope. Comparing Tables 9 and 11, the offsets between the SPB and OBSI data for trucks are 8.9 to 9.3 dB less than for light vehicles indicating that trucks are much louder than light vehicles on average throughout the data range of the measurements. Further comparing the standard deviations for light vehicles and heavy trucks, it is seen that values for trucks are not much larger than those of light vehicles, typically no more than 0.2 dB. This suggests that the SPB levels could be estimated from OBSI data measured with either test tire with almost the same confidence for both light vehicles and heavy trucks.

Prediction of SPB Data from OBSI Data

The applicability of OBSI data to assessing the noise performance of in-service pavement is demonstrated by how well SPB levels can be predicted from OBSI data. To demonstrate

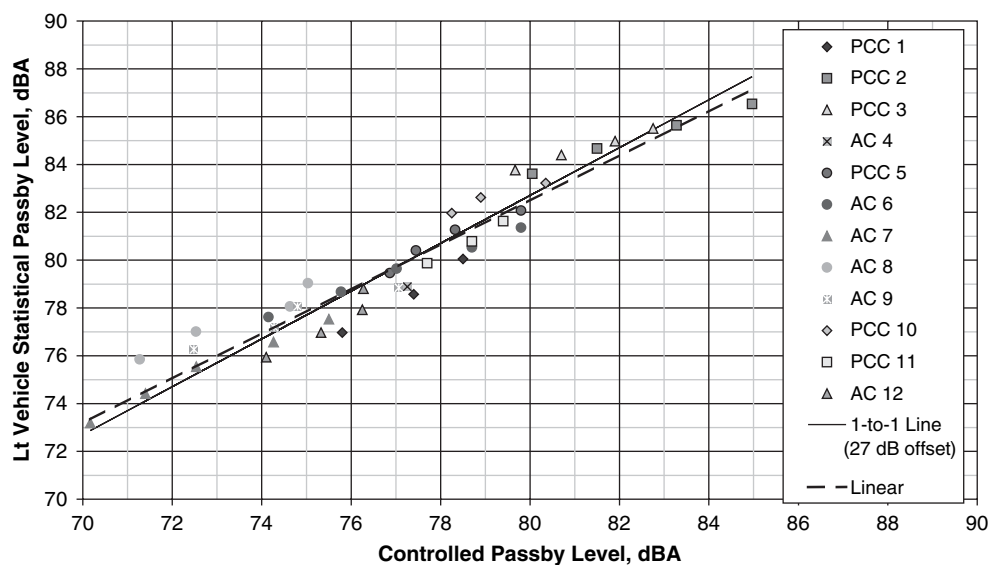

Figure 18. Statistical light vehicle passby levels at 25 ft versus controlled vehicle passby level for the SRTT at all test sites and speeds.

Table 10. Metrics for CPB versus light vehicle SPB relationship.

Cross-Plot Metrics	25 ft Microphone Distance		50 ft Microphone Distance	
	SRTT	Dunlop	SRTT	Dunlop
Slope	0.94	1.02	0.92	0.94
r ²	0.93	0.96	0.94	0.96
Offset, dB	2.7	1.0	2.6	1.1
Std Dev, dB	0.9	0.7	1.0	0.8
Avg Dev, dB	0.7	0.6	0.7	0.7

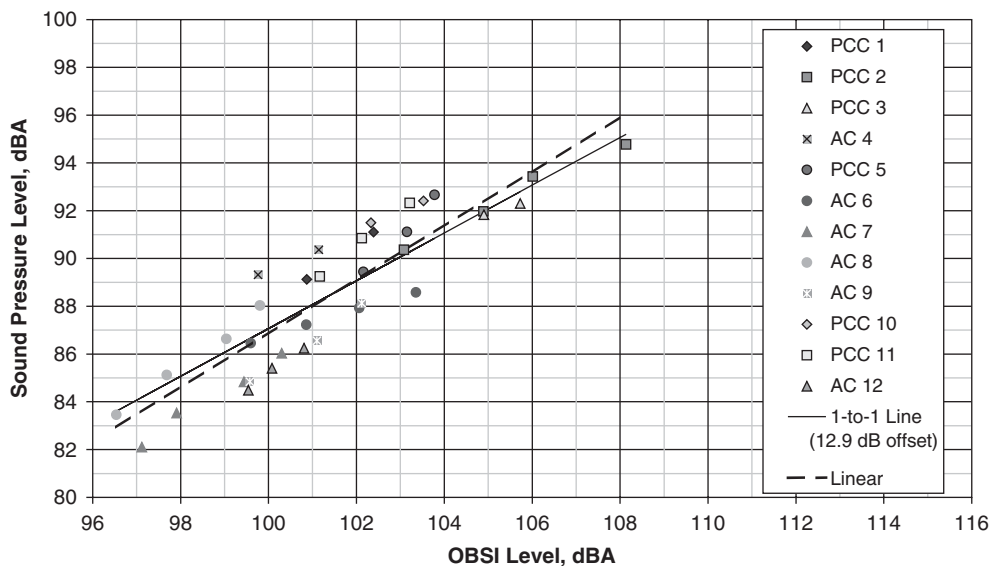

Figure 19. Statistical heavy-truck passby levels at 25 ft versus OBSI level for the SRTT at all test sites and speeds—raw data.

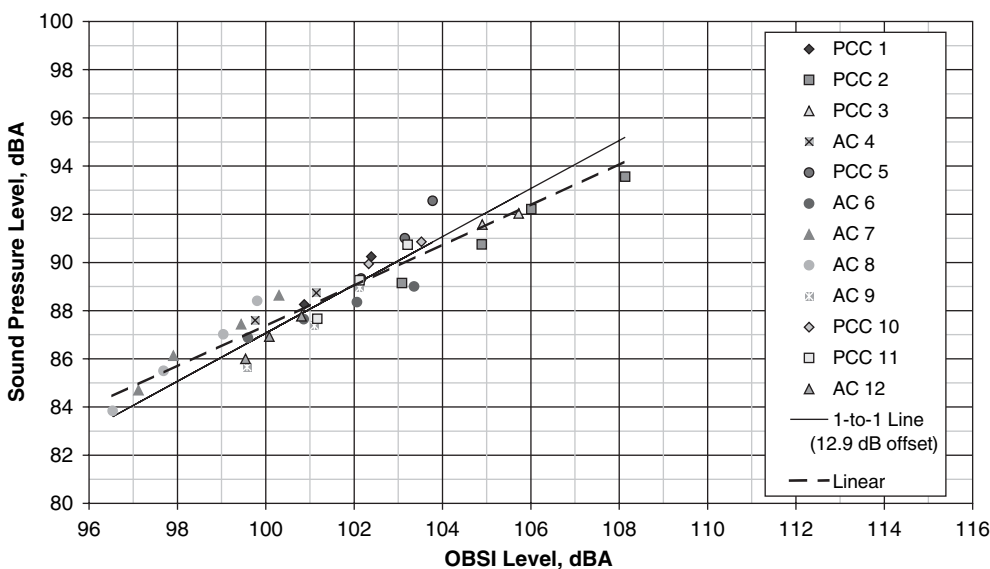

Figure 20. Statistical heavy truck passby levels at 25 ft versus OBSI level for the SRTT at all test sites and speeds—normalized data.

Table 11. Metrics for heavy truck SPB versus OBSI relationship.

Cross-Plot Metrics	25 ft Microphone Distance				50 ft Microphone Distance			
	SRTT		Dunlop		SRTT		Dunlop	
	Raw	Norm	Raw	Norm	Raw	Norm	Raw	Norm
Slope	1.13	0.84	1.14	0.85	1.17	0.76	1.22	0.79
r ²	0.82	0.89	0.77	0.85	0.81	0.79	0.78	0.77
Offset, dB	12.9	12.9	14.9	14.9	19.6	19.2	21.6	21.0
Std Dev, dB	1.4	0.9	1.6	1.0	1.6	1.2	1.8	1.2
Avg Dev, dB	1.2	0.7	1.3	0.8	1.3	1.0	1.5	1.1

this applicability in a less abstract manner than cross-plots, the offsets for the 1-to-1 lines from Tables 8 and 10 can be subtracted from the OBSI data for each tire. This yields a predicted SPB level based on either the SRTT or Dunlop tire at whatever OBSI test speed is selected. Depending on which offset is selected, the SPB levels for light vehicles or trucks at 25 ft or 50 ft can be predicted. Further, the predicted SPB levels can be compared to both the raw and normalized SPB levels. This is illustrated for the primary test speed of 60 mph in Figures 21 through 24.

For light vehicle and the 25-ft microphone distance (Figure 21), several features are noted. First, there is virtually no difference whether the predicted SPB levels are generated from the SRTT or Dunlop tires. Second, the normalized (measured) SPB values compare quite well to the predicted levels with an average difference of only 0.1 dB and standard deviations of 0.8 dB. Third, when site-to-site differences are not normalized, the variation between the predicted and measured SPB levels varies more with standard deviations of 1.2 and 1.4 dB depending on the tire. For heavy trucks at 25 ft (Figure 22), the behav-

ior is almost identical to that for the light vehicles with an average difference of 0.1 dB and standard deviations of 0.7 and 0.8 dB for the normalized SPB data and 1.3 and 1.5 dB for the uncorrected SPB data.

For light vehicles at the 50-ft microphone positions (Figure 23), the results are similar to the 25-ft results except that a larger variance occurs between the predicted SPB and the uncorrected data. The normalized SPB maintains an average difference from the predicted of 0.1 dB with a standard deviation of 0.7 and 0.8 dB. For the uncorrected data, the standard deviations are 2.0 and 2.2 dB depending on the tire. This larger variance of the uncorrected 50-ft data is expected based on the average difference in level between the 25-ft and 50-ft microphone. These differences were found to vary as much as 3.6 dB between sites (see Appendix D).

The same trends are seen for the trucks at 50 ft (Figure 24) with the exception of a larger standard deviation (0.9 to 1.0 dB) between the predicted and normalized SPB data. This SPB prediction methodology was applied to OBSI and SPB data obtained at other vehicle speeds and resulted

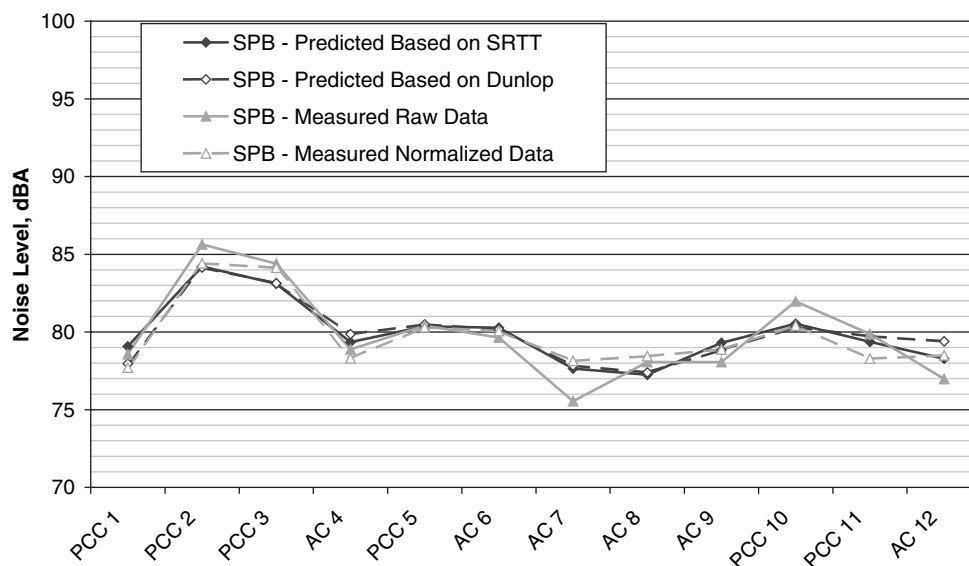

Figure 21. Predicted SPB based on SRTT and Dunlop tires and measured light vehicle SPB levels at 60 mph and 25 ft—raw and normalized.

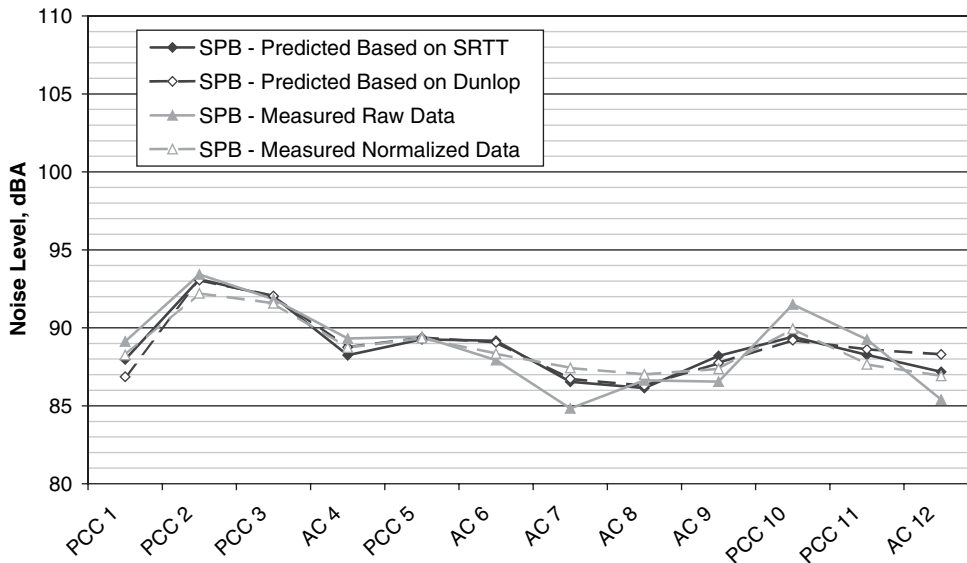

Figure 22. Predicted SPB based on SRTT and Dunlop tires and measured heavy truck SPB levels at 60 mph and 25 ft—raw and normalized.

in essentially the same findings (details are provided in Appendix D).

In general, SPB can be predicted from OBSI by subtracting the offset values established in this research using either of the two test tires. The offsets appropriate for each tire, vehicle type, and microphone distance are provided in Table 12 along with the standard deviations expected for such predictions.

In applying these values using different test tires (SRTT or Dunlop design), it should be realized that standard deviations

do not include differences that may be encountered from tire-to-tire variation. For each case, two standard deviations are given: one for the normalized SPB data and one for the uncorrected SPB data. The first of these can be thought of as the standard deviation that would be expected for an average of sites with the same pavement. The second standard deviation is that which should be applied to a specific site for those that are geometrically and acoustically in the range of the sites included in this research. For either the average or site-specific case, the off-

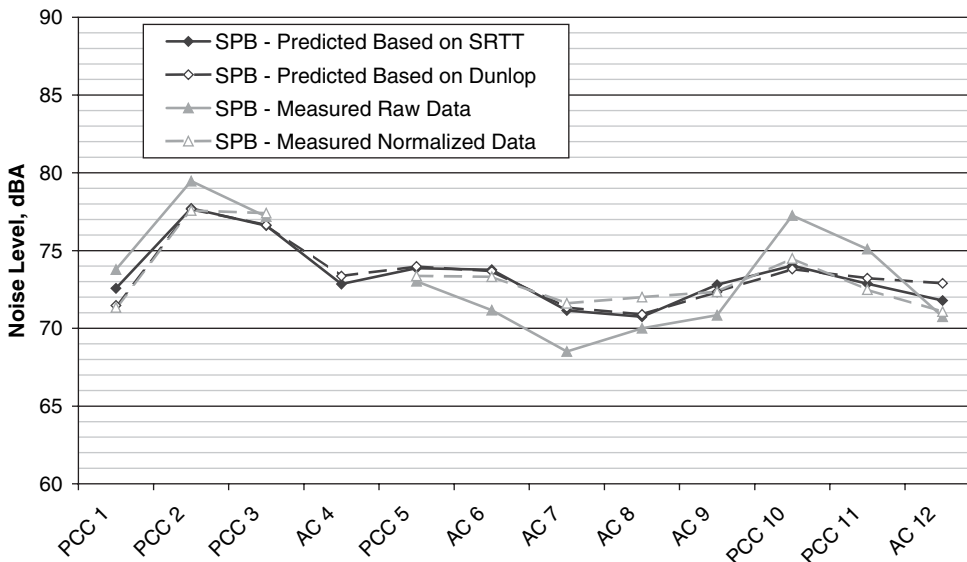

Figure 23. Predicted SPB based on SRTT and Dunlop tires and measured light vehicle SPB levels at 60 mph and 50 ft—raw and normalized.

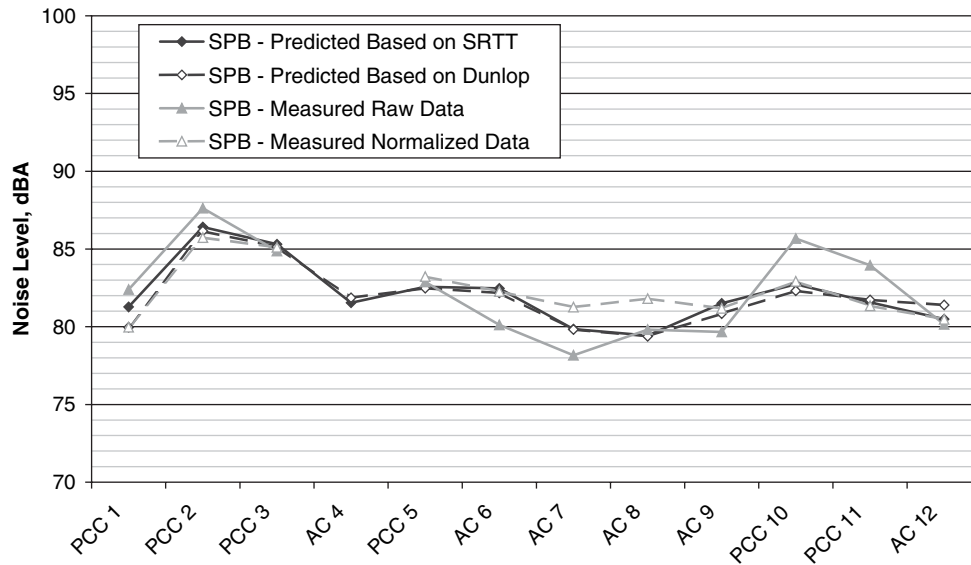

Figure 24. Predicted SPB based on SRTT and Dunlop tires and measured heavy truck SPB levels at 60 mph and 50 ft—raw and normalized.

set between measured OBSI level and predicted SPB level is the same and only the expected accuracy varies. The standard deviations in Table 12 again indicate that SPB levels can be predicted from the OBSI data with virtually the same level of confidence for both light vehicle and heavy trucks at a distance of 25 ft.

Test Tires

As noted in Figures 21 through 24, SPB levels predicted from OBSI using the SRTT and Dunlop tires are almost identical when the appropriate offset is used. From Table 11, the offsets for the Dunlop tire are 1.8 to 2.0 dB greater than for the SRTT, with the Dunlop producing higher noise levels. These tire differences are consistent with those measured for the OBSI parameter testing described in Chapter 4. The plot of passby level versus vehicle speed provided in Appendix D indicates that the Dunlop tire typically produced higher passby levels than the SRTT and generally approximated the levels of the light vehicle SPB more closely than the SRTT. In regard to

truck SPB results, no evidence was found to suggest that the more aggressive tread of the Dunlop tire would better represent truck SPB variation with pavement than would the SRTT. Since the two tires performed equally well in producing predicted SPB levels for both light vehicles and heavy trucks, the decision on which test tire to be used in the OBSI procedure can be based on other, non-noise related issues (e.g., long-term availability).

Summary

In order to demonstrate the ability of the recommended OBSI test procedure to characterize the noise performance of in-service pavements, an extensive measurement program was completed. This program included the measurement of 1,343 light vehicle passby events and 539 heavy truck passby events at 12 sites and pavements in the states of Iowa and California, and measurements of controlled test vehicle passby events and OBSI. By comparing the CPB and OBSI data, significant site-to-site variation of up to 4.2 dB was identified. Site variation was

Table 12. Offsets for predicting SPB from OBSI with expected standard deviations.

Application	Offsets (to be subtracted from OBSI level), dB		Site Average Standard Deviation, dB	Specific Site Standard Deviation, dB
	SRTT OBSI	Dunlop OBSI		
Light Vehicles at 25 ft	21.8	23.8	0.8	1.3
Heavy Trucks at 25 ft	12.9	14.9	0.8	1.4
Light Vehicles at 50 ft	28.3	30.3	0.8	2.1
Heavy Trucks at 50 ft	19.2	21.0	1.0	1.8

also indicated by average differences of up to 3.7 dB between the 25-ft and 50-ft passby levels across the various sites. The site information from the CPB and OBSI data was used to normalize the SPB to OBSI data and establish a 1-to-1 relationship between them for each microphone distance and vehicle type. It was then demonstrated that these relationships could be used to effectively predict SPB results based on OBSI data for the average of sites included in the field testing with a standard deviation of 0.8 dB for both light vehicles and heavy trucks at a distance of 25 ft from the roadway. For 50 ft, a standard deviation of 0.8 and 1.0 dB was maintained for light vehicles

and heavy trucks, respectively. Although the SRTT produced lower noise levels than the Dunlop test tire, essentially, no differences were found when using the data to predict SPB data. Some indication of noise sources other than tire-pavement was found for heavy trucks, particularly at lower speeds (below ~60 mph) where engine/exhaust noise are expected to become more pronounced. However, the ability to predict SPB levels for heavy trucks from OBSI data alone was almost equal to that for light vehicles. Also, no issues were discovered that would limit the use of the 25-ft microphone distance for heavy trucks.

CHAPTER 6

Conclusions, Recommendations, and Suggested Research

Conclusions

Based on the research work completed in this project, the OBSI method was found to be the preferred approach for developing an at-the-source tire-pavement noise test procedure. The CPX approach was not desired due to spectral distortion observed relative to the passby data, a slightly lower ability to correlate with overall passby levels, practical concerns in the use of a CPX trailer or “facility,” and the expense of acquiring and maintaining a CPX trailer. The two methods were found, however, to correlate well with each other on an overall level basis and one could be used to reliably estimate the other, particularly after some initial calibration.

Site-to-site variation was found to be a significant issue affecting the correlation between OBSI and passby measurements, as observed in sound propagation measurements. In using passby data to quantify pavement noise performance, more strict requirements on measurement sites need to be considered for direct comparison of data from different sites. Simultaneous OBSI and CPB measurements were found to be an effective means of identifying and quantifying site biases.

OBSI data can be used to predict SPB levels for light vehicles and heavy trucks using offsets applied to the OBSI levels. This yields predictions for an “average” site as defined by the sites tested in this research. Use of the offsets defined in this work should provide a reasonable estimate of passby levels based on measured OBSI levels. For specific sites of varying properties, greater variance could be expected between predicted and measured levels, however, a better defined “average” site would probably not help to reduce this uncertainty.

Consistent with the REMELs database (22), heavy trucks were found to be about 9 dB louder than light vehicles. Unexpectedly, the SPB levels for trucks could be almost as accurately predicted from OBSI data as it could for light vehicles. The analysis indicated that at lower speeds (i.e., 50 to 55 mph) some increase in noise level, which is not attributable to tire-pavement noise alone, occurs with trucks likely due to engine/exhaust noise. However, within a standard deviation of 1 dB,

truck SPB levels could be predicted even for 50 mph. Also unexpected was the finding that the more aggressive “winter” Dunlop tire did not provide any better correlation to the truck passby levels than the SRTT. This leads to the conclusion that changes in passby noise levels with pavement for heavy trucks can be fairly well predicted on the basis of tire-pavement levels alone at least for speeds of 50 mph and above. However, it is unclear why the levels are typically almost 10 dB higher for trucks than light vehicles.

Within the uncertainty of site-to-site variation encountered for non-porous pavements (Test Sites 1 through 11), the porous Test Site 12 did not display any unique behavior. The spectrum shape of the OBSI levels was unique relative to the other sites and displayed the same shape as the porous pavement Test Site S4. As a result, the Test Site 12 pavement would be expected to have similar sound-absorbing properties as those documented for S4. However, much of the difference between this pavement and the others appears to be accounted for in the OBSI data. For Test Site 12, actual propagation over the porous pavement was quite limited; larger effects may be encountered for propagation over multiple lanes of sound-absorbing pavement.

In regard to the test tire, no overwhelming experimental evidence was found to favor one tire over the other. The Dunlop tire produced levels closer to those measured for the light vehicle statistical passby events, however, both tires tracked equally well with the differences seen in the SPB data for different pavements. Both tires displayed similar sensitivity to test variables in most cases. With the lack of a clear difference based on acoustic performance, the selection of the test tire can be made on the basis of other, non-noise related issues.

Recommendations

Based on the findings of this research, recommendations for the implementation and enhancement of the test procedure and other recommendations are provided.

Test Procedure Implementation and Enhancement

The test procedure provided in Attachment 1 is recommended for adoption as a national standard. To re-enforce the application of the findings of this research, technical presentations should be made to professional organizations and the pavement industry and the results communicated to interested groups.

Although there was no technical preference for the SRTT, the SRTT should be specified as the primary test tire for the OBSI procedure because of its expected long-term availability; additional light passenger vehicle tire types such as winter tires should not be considered at this time. Periodically, the choice of the SRTT in regard to issues that could not be investigated in this research such as tire-to-tire variability and consistency of noise generation over time should be reviewed. Initial investigation of these issues has been recently reported in other research that indicated minimal tire-to-tire variation and little difference between new and used tires (23). These preliminary findings should be verified over a longer time period.

Effects of temperature were indicated to some degree in the parameter testing. However, the results were too limited to develop any trends or potential corrections to account for either air and/or pavement temperature. The effects of temperature should be investigated using the OBSI test procedure developed in this research, either through collective experience of multiple users or directed research. Similarly, tire rubber hardness due to tire aging could not be addressed in the current research and should be further documented by users of the recommended procedure. In the testing performed in this research, no adverse effects of ambient wind conditions were noted on the OBSI data. However, recent wind tunnel testing (19) indicated that some effect may occur under specific speed and cross wind conditions. Therefore, the effect of ambient wind speed and direction should be monitored in future work to determine if testing should be restricted due to wind conditions.

In order to establish the expected reproducibility of OBSI measurements from one user to another, comparative “rodeo” testing should be done between users following the recommended procedure. This research focused on repeatability for a single user/measurement combination. In application, tire-to-tire, data acquisition system-to-system, and fixture-to-fixture variation may create a wider variance than this research indicates. As an example, in this research, a small, but consistent difference (–0.3 to –0.6 dB) in OBSI level was noted between data taken with the horizontal single probe and vertical dual probe fixtures. In comparing one user’s implementation of the OBSI procedure to another, such subtle differences may combine with other differences due to tires and instrumentation to produce user biases on the order of 1 dB. Some other variables may require further specification in the pro-

cedure once differences are identified and understood. This rodeo testing should determine the reproducibility among users and the reasons for differences greater than 1 dB in overall level.

In addition, issues such as the effect of roadway curvature, roadway grade, banking, roadside reflecting surfaces, and the presence of other vehicles near the probe may be of concern but are not currently documented. For undriven tires, curvature, grade, and banking may not be significant issues under moderate conditions, however, they are currently undefined in terms of actual data. Strict adherence to the data quality indicators is recommended to avoid data that are influenced by the presence of sound-reflecting surfaces or nearby vehicles.

Other Recommendations

For SPB and CPB standard measurements, a 25-ft microphone distance from the center of the lane of vehicle travel should be considered. Although even at this reduced distance site-specific differences were found, the 50-ft distance introduced additional site-specific variation. Also, for the 25-ft distance, clean passby events could be more easily acquired due to the greater signal-to-noise ratio. No adverse effects for heavy truck passby events were noted in the measurements.

Current procedures for SPB should be further evaluated to identify means to minimize site-specific effects. Procedures for SPB and CPB measurements should be developed for consideration and adoption as a national standard.

The results of passby measurements obtained in this work should be evaluated relative to the REMELs database to provide insight into how to calibrate OBSI data to those data. Such calibration could facilitate using OBSI data in traffic noise prediction such as is done in the FHWA Traffic Noise Model.

Suggested Research

To enhance the results of this research the following topics are suggested for further research:

- Investigations of the effects of temperature and wind conditions on OBSI measurement. This research will determine temperature limits and/or correction factors as well as limits for wind conditions.
- Investigations of the effect of porous (acoustically absorbing) pavement on sound propagation from the OBSI measurement point to wayside receiver locations and incorporation of such effects in traffic noise prediction models.
- Investigations of the effects of site-specific variables on SPB and CPB measurements to recommend limits for the more important variables or otherwise site corrections.
- Development of procedures for CPB and SPB for consideration and adoption as a national standard.

References

1. Rymer, B. and Donovan, P. "Tire-Pavement Noise Intensity Testing in Europe: The NITE Study and Its Relationship to Ongoing Caltrans Quiet Pavement Activities," Proceedings of the 80th Meeting of the Association of Asphalt Paving Technologists, Long Beach, CA, March 7–9, 2005.
 2. International Organization of Standardization. "ISO/CD 11819-2. Acoustics—Method for measuring the influence of road surfaces on traffic noise—Part 2: the close-proximity method," ISO, Geneva, Switzerland, 2000.
 3. Donovan, P. "Tire-Pavement Interaction Noise Measurement under Vehicle Operating Conditions of Cruise and Acceleration," SAE Paper 931276, Society of Automotive Engineers Noise and Vibration Conference Proceedings, Traverse City, MI, May 1993.
 4. Hanson, D., "Tire-Pavement Noise Characteristics," Proceedings of the 80th Meeting of the Association of Asphalt Paving Technologists, Long Beach, CA, March 7–9, 2005.
 5. Scofield L. and Donovan, P. "Early Results of the Arizona Quiet Pavement Program," Proceedings of the 80th Meeting of the Association of Asphalt Paving Technologists, Long Beach, CA, March 7–9, 2005.
 6. Donovan, P. and Rymer, B. "Quantification of Tire-pavement Noise: Application of the Sound Intensity Method," Proceedings of Inter-Noise 2004, Prague, the Czech Republic, August 2004.
 7. McNerney, M., Landsberger, B., Turen, T., and Pandelides, A. *Comparative Field Measurements of Tire-pavement Noise of Selected Texas Pavements*, Center for Transportation Research, the University of Texas at Austin, Austin, TX, *Report No. 7-2957-2*, April 2000.
 8. Ruhala, R. J. and Burroughs, C. B. "Tire-Pavement Interaction Noise Source Identification Using Multi-Planar Nearfield Acoustical Holography," Proceedings of the Society of Automotive Engineers Noise and Vibration Conference and Exposition, paper no. 1999-01-1733, May 1999.
 9. Bernhard, R. and Thornton, W. "Tire/Pavement Noise Strategic Planning Workshop: September 14–16, 2004 Proceedings and Roadmap," FHWA-HEP-05-007, HL 2004-19, SQDH 2004-4, The Institute for Safe, Durable Highways, School of Mechanical Engineering, Purdue University, September 2004.
 10. Sandberg, U. and Ejsmont, J. *The Tyre/Road Noise Reference Book*, INFORMEX, Ejsmont & Sandberg Handelsbolag, Harg, SE-59040 Kisa, Sweden, 2002.
 11. GM North American Engineering Standards. "Road Tire Noise Evaluation Procedure—GMN7079TP," General Motors Corporation, Detroit, MI, 2004.
 12. Donovan, P. "An Assessment of the Tire Noise Generation and Sound Propagation Characteristics of an ISO 10844 Road Surface," SAE Paper 971990, Society of Automotive Engineers Noise and Vibration Conference Proceedings, Traverse City, MI, May 1997.
 13. ASTM F 2493, Standard Specification for P225/60R16 97S Radial Standard Reference Test Tire.
 14. Ejsmont, J. (editor) *Development of Procedures for Certifying Noise Testing Equipment*, University of Technology Publishers, Wydawnictwo Politechniki Gdańsk, ul. G. Narutowicza 11/12, 80-952 Gdańsk, Poland, 2005.
 15. Donovan, P. *Further Development of the Sound Intensity Method of Measuring Tire Noise Performance of In-Situ Pavements*, California Department of Transportation, Division of Environmental Analysis, Sacramento, CA, prepared by Illingworth & Rodkin, Inc., Petaluma, CA, January 2006.
 16. Beranek, L. and Vér, I. *Noise and Vibration Control Engineering: Principles and Applications*, John Wiley & Sons, Inc., New York, NY, 1992, p. 61.
 17. Wiegand, P., Cable, J., Reinert, S., and Tabbert, T. "Field Experiments of Current Concrete Pavement Surface Characteristics Practices: Iowa Data Collection and Analysis," Report No. FHWA DTFH61-01-X-00042 (Project 15, Part 2) IHRB Project TR-537, Center for Transportation Research and Education, Iowa State University, Ames, IA, December 2005.
 18. Rochat, J., Read, D., and Fleming, G. *Status Report: Caltrans Rte 138 Tire/Pavement Noise Study*, Technical Memorandum, Volpe Center Acoustics Facility, U.S. Department of Transportation, June 2004.
 19. Donovan, P. "Influence of PCC Surface Texture and Joint Slap on Tire/Pavement Noise Generation," Proceedings of NoiseCon 2004, Baltimore, MD, July 2004.
 20. Lee, C. and Fleming, G. *Measurement of Highway-Related Noise*, U.S. Department of Transportation, Report No. DOT-VNTSC-FHWA-96-5, 1996.
 21. International Organization of Standardization. "ISO/CD 11819-1. Acoustics—Measurement of the Influence of Road Surfaces on Traffic Noise—Part 1: Statistical Pass-by Method," ISO, Geneva, Switzerland, 2000.
 22. Fleming, G., Rapoza, A., and Lee, C. "Development of National Reference Energy Mean Emission Levels for the FHWA Traffic Noise Model (FHEA TNM), Version 1.0," U.S. Department of Transportation, *Report No. DOT-VNTSC-FHWA-96-2*, 1996.
 23. Donovan, P., Lodico, D., and Rymer, B. "Considerations in the Standardization of On-Board Sound Intensity (OBSI) for Highway Pavement Evaluation," Proceedings of NoiseCon 2007, Reno, NV, October 2007.
-

ATTACHMENT

Proposed Method of Test for Measurement of Tire-Pavement Noise Using the On-Board Sound Intensity (OBSI) Method

Disclaimer

The proposed test method is a recommendation of the NCHRP Project 1-44 staff at Illingworth & Rodkin, Inc., and it includes some modifications to AASHTO Designation Standard TP076-08, Provisional Standard Test Method for the Measurement of Tire/Pavement Noise Using the On-Board Sound Intensity (OBSI) Method. These modifications have not been approved by NCHRP or by any AASHTO Committee or formally accepted for the AASHTO specifications. The research conducted in this project provided a basis for this provisional standard.

Proposed Standard Method of Test for Measurement of Tire-Pavement Noise Using The On-Board Sound Intensity Method (OBSI)

1. Scope

- 1.1 This document defines the procedures for measuring tire-pavement noise using the on-board sound intensity (OBSI) method.
- 1.2 OBSI measurements at the source can be used to characterize the in-service noise performance of pavements.
- 1.3 This procedure is anticipated to change as experience increases and additional research allows for the establishment of testing variables over a larger data set.
- 1.4 This standard does not purport to address all of the safety problems, if any, associated with the its use. It is the responsibility of the user of this standard to establish appropriate safety and health practices and determine the applicability of regulatory limitations prior to use.

2. Referenced Documents

- 2.1 ASTM Standards
 - 2.1.1 F2493 Standard Specification of P225/60R16 Radial Standard Reference Test Tire.

2.2 ANSI Standards

- 2.2.1 ANSI S1.9-1996 (R2006): Instruments for the Measurement of Sound Intensity.
- 2.2.2 ANSI S1.40-2006: American National Standard Specifications and Verification Procedures for Sound Calibrators.
- 2.2.3 ANSI S1.11 Specification for Octave-Band and Fractional-Octave-Band Analog and Digital Filters.

3. Terminology

- 3.1 Sound intensity—The instantaneous product of acoustic pressure and acoustic particle velocity at a point with direction of propagation defined by the particle velocity vector. It corresponds to the acoustic energy flow through a unit area and the units of Watts per square meter.
- 3.2 Sound intensity level—Ten times the logarithm of the time averaged sound intensity divided by the reference sound intensity (I_{ref}) of 1×10^{-12} watts per square meter [$10 \times \text{Log}(I/I_{ref})$].
- 3.3 Coherence—A measure of the linear dependency of two signals with a value of 0 being no dependency, and a value of 1 being perfect linear dependence. Mathematically, it is the magnitude of the cross-spectrum between two signals squared divided by the product of the auto-spectrum of both signals.
- 3.4 SI_{index} —The sound intensity-to-sound pressure level index defined by subtracting the sound intensity level from the sound pressure level.

4. Summary of Methods

A method is described in which a sound intensity probe is installed directly on a test vehicle using an appropriate fixture and tire-pavement noise from a standard test tire is measured. Data is acquired over a 440-ft section of pavement at a steady test speed. Where possible, a test speed of 60 mph is used with alternative speeds of 35 and 45 mph depending on

local conditions and regulations. Sound intensity levels are measured at the leading and trailing edge contact patch of the test tire, either simultaneously or consecutively, and a minimum of two runs for each probe location are made. Data is acquired for $\frac{1}{3}$ octave bands centered at 400 to 5,000 Hz and checked to ensure that data quality criteria are met. The results from the leading and trailing edge positions for each run are averaged together and then the tire averages for individual runs are averaged, resulting in the overall A-weighted OBSI level and $\frac{1}{3}$ octave band levels that are reported for each pavement section.

5. Significance and Use

- 5.1 This test method defines procedures to quantify tire-pavement noise very near the source in isolation from other vehicle noises.
- 5.2 Using the method and the specified standard test tire, measurements can be compared across different pavements and among different users of the method.
- 5.3 The method can also be used to compare the tire-pavement noise generation of different tires, including truck tires, if the intent of the measurements is to compare tire noise generation on some defined set of pavements.

6. Equipment

6.1 Acoustic Instrumentation

- 6.1.1 The sound intensity level shall be measured using a sound intensity meter or equivalent measurement system meeting the requirements of ANSI S1.9-1996 (R 2006) and requirements of ANSI S1.11.
- 6.1.2 The sound intensity probe shall consist of two $\frac{1}{2}$ " phased matched condenser microphones installed on two $\frac{1}{2}$ " microphone preamplifiers. These shall be attached to a plastic probe holder that provides a 16-mm center-to-center spacing of the microphones as measured from the center of the microphone diaphragms resulting in a "side-by-side" SI probe configuration. The midpoint between these microphones shall be used in positioning the probe. The microphones shall be protected from airflow using a spherical foam windscreen approximately $3\frac{1}{2}$ " in diameter.
- 6.1.3 Acoustic calibration of the entire data acquisition system shall be performed with a sound calibrator that fulfils the requirements of ANSI S1.40 Class 0 or Class 1.

6.2 Non-Acoustic Instrumentation

- 6.2.1 Air and surface temperatures shall be measured with a device with an overall accuracy of $\pm 1.8^\circ\text{F}$.
- 6.2.2 Wind speed shall be measured with a device with an overall accuracy of $\pm 5\%$.

- 6.2.3 Tire inflation pressure shall be measured with a device with an overall accuracy of ± 1 psi.
- 6.2.4 Vehicle speed shall be measured with a device with an overall accuracy of ± 1 mph. Vehicle speedometers may be used if independently calibrated by a device with an overall accuracy of ± 1 mph.

6.3 Test Tire

- 6.3.1 Measurements shall be conducted using the ASTM F 2493 P225/60R16 (16 inch) Standard Reference Test Tire (SRTT). Test tires shall be operated in only one rotational direction for the test life of the tire. The test tire shall be mounted on the right side of the test vehicle on a non-driven axle.
- 6.3.2 Unless a specific inflation is required, the test tire shall be inflated to a pressure of 30 ± 2 psi cold.
- 6.3.3 The test tire shall be loaded with the existing, unloaded weight of vehicle plus the personnel and equipment to perform the testing unless specified otherwise in the test plan. Loading of the test tire shall be 850 ± 100 lbs.

6.4 Test Vehicle

- 6.4.1 The test vehicle shall provide a non-driven, non-steering tire/wheel mounting location.
- 6.4.2 The tire and wheel at the test position shall rotate freely without extraneous noise of any kind.

7. Measuring Procedure

7.1 Probe Location

- 7.1.1 Sound intensity shall be measured at two points, one opposite the leading edge of the contact patch and one opposite the trailing edge (Figure 1)
- 7.1.2 The leading and trailing edges of the contact patch shall be defined as the points where the tire tread is 0.1 inch above the pavement surface (Figure 2).
- 7.1.3 The measurement points shall be $3 \pm \frac{1}{4}$ inches above the ground.
- 7.1.4 Measurements shall be made in a plane surface parallel to the sidewall of the tire with the measurement plane $4 \pm \frac{1}{2}$ inches from the tire sidewall at the measurement location.
- 7.1.5 The probe shall be supported by a fixture capable of maintaining it in the specified position for the duration of the test. The fixture shall be designed to minimize extraneous noise and wind turbulence. Measurements of the leading and trailing edge may be made concurrently using a two-probe fixture configuration.

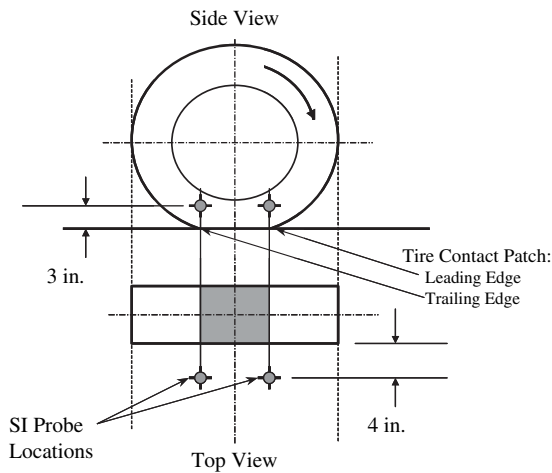

Figure 1. OBSI probe locations relative to test tire and pavement surface.

7.2 Acoustic Calibration

7.2.1 Prior to each set of measurements, the sound intensity probes and measurement system shall be calibrated with the acoustic calibrator. At the end of each set of measurements or after 4 hours (whichever is shorter), the calibration shall be repeated. If the second calibration differs from the first by more than ± 0.2 dB, the set shall be repeated.

7.2.2 Local values for air temperature and barometric pressure shall be entered into the analyzer for proper calculation of sound intensity prior to OBSI measurement.

7.3 Environmental Conditions

7.3.1 Pavement dampness—The pavement shall be dry. For known non-porous pavements, this criterion shall be followed from visual inspection. For porous pavements, testing shall not be conducted on the pavement if it is known that rain has occurred in the vicinity of the test site within 48 hours.



Figure 2. Orientation of the OBSI probe to the edge of the tire contact patch—trailing edge position.

7.3.2 Temperature—Air and pavement temperature shall be measured at the beginning of the OBSI measurement set and monitored such that changes of $\pm 10^\circ\text{F}$ are detected. Testing shall be restricted to a temperature range from 40 to 105°F unless the purpose of the testing is intended to evaluate the effects of temperature. During the OBSI measurements, tire surface temperature shall be measured every half-hour or sooner if environmental conditions are rapidly changing.

7.3.3 Wind speed and direction—Average wind speed and direction shall be monitored and noted throughout the testing. No restrictions on wind speed or direction shall be applied. However, data validity checks shall be used to identify when wind conditions have adverse effects on the OBSI measurement.

7.4 Test Section

The test section shall have the same nominal material and surfacing for its length. The test section shall be free of debris to the extent possible. The test section shall be nominally straight and free of dips and swells.

7.5 Acoustic Data Acquisition

7.5.1 Sound intensity shall be measured using a “linear average” (energy average) over a specific time interval. Generally, an averaging time of 5 seconds shall be used for a test speed of 60 mph. For 45 mph, the averaging time is 6.7 seconds. For 35 mph, it is 8.6 seconds. Pavement sections that are too short to allow this averaging time or are suspected of not being consistent throughout the specified shorter averaging period are acceptable as long as all Data Quality Criteria are met.

7.5.2 The mean sound pressure level of the probe microphone pair and coherence of the sound pressure signals between the microphone pair shall be measured. Microphone signals shall also be recorded for additional post-processing if required.

7.5.3 OBSI and other acoustic data shall be acquired at minimum for the $\frac{1}{3}$ octave bands centered at 400 to 5,000 Hz.

7.5.4 Microphone signals shall be filtered by the A-weighting spectrum shape at the input to the analyzer.

7.5.5 For each 440-ft section of pavement tested, a minimum of two measurements for the leading and trailing edge probe locations shall be made. It is recommended that three or more measurements of each section be performed. If

data quality criteria are not met for at least two of the runs, the measurements shall be repeated until they are.

7.6 Data Quality Criteria

- 7.6.1 Audio monitoring—The sound pressure signals shall be acoustically or visually monitored as they are acquired. Any unusual noises such as rattles, excessive wind noise, stones embedded in the tire tread, etc., shall be observed and the cause of such noises shall be identified and remedied.
- 7.6.2 The direction of the sound intensity shall be positive for all data reported as valid. Positive direction is defined to be sound propagating away from the test tire.
- 7.6.3 Mean sound pressure level minus sound intensity level (SI_{index}) shall be less than 5 dB and greater than -1 dB in all $\frac{1}{3}$ octave bands for all data reported as valid.
- 7.6.4 Coherence—The ordinary coherence between the two microphones constituting the probe shall be greater than 0.8 for all frequencies below 4,000 Hz.
- 7.6.5 Overall A-weighted sound intensity levels for measurements made of the same pavement section shall be within 1 dBA. The range in sound intensity level between runs shall be less than 2 dB in all $\frac{1}{3}$ octave bands for all data reported as valid.

8. Data Processing

OBSI data shall be processed into levels representing the combination of the noise sources at the leading

and trailing edge of the contact patch. If a single probe is used, multiple runs shall be averaged together arithmetically for the leading and trailing edges separately. The leading and trailing averages shall then be averaged on an energy basis. If dual probes are used, the level of the two probes shall be averaged on an energy basis for each run. The energy averages for individual runs shall then be averaged together arithmetically.

9. Data Reporting

- 9.1 The specific acoustic data reported shall depend on the specific needs of the test as defined in the test plan and final report. As a minimum, the following tire-pavement average data shall be reported: overall A-weighted OBSI level summed over the frequency range of valid data with the range noted; $\frac{1}{3}$ octave band levels over the range of valid data.
- 9.2 Any exceptions to this stated OBSI procedure must be reported.
- 9.3 Other information that shall be reported include air and pavement temperature range during testing, location and description of the test pavement, the date of the measurement, period of the performance of the measurements, and test speed.
- 9.4 Additional information to be made available on request shall include wind conditions during the measurements, barometric pressure used for air density calculation, coherence, SI_{index} , probe configuration, and test vehicle make and model.

10. Precision and Bias

- 10.1 Precision is expected to be within 0.5 dB.
 - 10.2 Bias is expected to be within 1.5 dB.
-

Appendixes A, B, C, and D

Unpublished Material

Appendixes A, B, C, and D contained in the research agency's final report are not published herein. Copies are available on the TRB website at http://trb.org/news/blurb_detail.asp?id=9956. The appendixes are titled as follows:

Appendix A: Review of Literature

Appendix B: Test Evaluation of Candidate Methods and Recommendation for Test Procedure Development

Appendix C: Results of Test Parameter Evaluation

Appendix D: Demonstration Testing of OBSI Procedure

Abbreviations and acronyms used without definitions in TRB publications:

AAAE	American Association of Airport Executives
AASHO	American Association of State Highway Officials
AASHTO	American Association of State Highway and Transportation Officials
ACI-NA	Airports Council International-North America
ACRP	Airport Cooperative Research Program
ADA	Americans with Disabilities Act
APTA	American Public Transportation Association
ASCE	American Society of Civil Engineers
ASME	American Society of Mechanical Engineers
ASTM	American Society for Testing and Materials
ATA	Air Transport Association
ATA	American Trucking Associations
CTAA	Community Transportation Association of America
CTBSSP	Commercial Truck and Bus Safety Synthesis Program
DHS	Department of Homeland Security
DOE	Department of Energy
EPA	Environmental Protection Agency
FAA	Federal Aviation Administration
FHWA	Federal Highway Administration
FMCSA	Federal Motor Carrier Safety Administration
FRA	Federal Railroad Administration
FTA	Federal Transit Administration
IEEE	Institute of Electrical and Electronics Engineers
ISTEA	Intermodal Surface Transportation Efficiency Act of 1991
ITE	Institute of Transportation Engineers
NASA	National Aeronautics and Space Administration
NASAO	National Association of State Aviation Officials
NCFRP	National Cooperative Freight Research Program
NCHRP	National Cooperative Highway Research Program
NHTSA	National Highway Traffic Safety Administration
NTSB	National Transportation Safety Board
SAE	Society of Automotive Engineers
SAFETEA-LU	Safe, Accountable, Flexible, Efficient Transportation Equity Act: A Legacy for Users (2005)
TCRP	Transit Cooperative Research Program
TEA-21	Transportation Equity Act for the 21st Century (1998)
TRB	Transportation Research Board
TSA	Transportation Security Administration
U.S.DOT	United States Department of Transportation