

## Roadside Safety Design and Devices: International Workshop

### DETAILS

---

0 pages | 8.5 x 11 | PAPERBACK

ISBN 978-0-309-43465-2 | DOI 10.17226/22642

### AUTHORS

---

Roadside Safety Design Committee

BUY THIS BOOK

FIND RELATED TITLES

### Visit the National Academies Press at [NAP.edu](http://NAP.edu) and login or register to get:

---

- Access to free PDF downloads of thousands of scientific reports
- 10% off the price of print titles
- Email or social media notifications of new titles related to your interests
- Special offers and discounts



Distribution, posting, or copying of this PDF is strictly prohibited without written permission of the National Academies Press. (Request Permission) Unless otherwise indicated, all materials in this PDF are copyrighted by the National Academy of Sciences.

TRANSPORTATION RESEARCH  
**CIRCULAR**

Number E-C172

February 2013

**Roadside Safety  
Design and Devices**

*International Workshop*

**July 17, 2012  
Milan, Italy**

TRANSPORTATION RESEARCH BOARD  
*OF THE NATIONAL ACADEMIES*

## **TRANSPORTATION RESEARCH BOARD 2013 EXECUTIVE COMMITTEE OFFICERS**

**Chair: Deborah H. Butler**, Executive Vice President, Planning, and CIO, Norfolk Southern Corporation, Norfolk, Virginia

**Vice Chair: Kirk T. Steudle**, Director, Michigan Department of Transportation, Lansing

**Division Chair for NRC Oversight: Susan Hanson**, Distinguished University Professor Emerita, School of Geography, Clark University, Worcester, Massachusetts

**Executive Director: Robert E. Skinner, Jr.**, Transportation Research Board

## **TRANSPORTATION RESEARCH BOARD 2012–2013 TECHNICAL ACTIVITIES COUNCIL**

**Chair: Katherine F. Turnbull**, Executive Associate Director, Texas A&M Transportation Institute, Texas A&M University System, College Station

**Technical Activities Director: Mark R. Norman**, Transportation Research Board

**Paul Carlson**, Research Engineer, Texas A&M Transportation Institute, Texas A&M University System, College Station, *Operations and Maintenance Group Chair*

**Thomas J. Kazmierowski**, Manager, Materials Engineering and Research Office, Ontario Ministry of Transportation, Toronto, Canada, *Design and Construction Group Chair*

**Ronald R. Knipling**, Principal, safetyforthelonghaul.com, Arlington, Virginia, *System Users Group Chair*

**Mark S. Kross**, Consultant, Jefferson City, Missouri, *Planning and Environment Group Chair*

**Joung Ho Lee**, Associate Director for Finance and Business Development, American Association of State Highway and Transportation Officials, Washington, D.C., *Young Members Council Representative*

**Peter B. Mandle**, Director, LeighFisher, Inc., Burlingame, California, *Aviation Group Chair*

**Harold R. (Skip) Paul**, Director, Louisiana Transportation Research Center, Louisiana Department of Transportation and Development, Baton Rouge, *State DOT Representative*

**Anthony D. Perl**, Professor of Political Science and Urban Studies and Director, Urban Studies Program, Simon Fraser University, Vancouver, British Columbia, Canada, *Rail Group Chair*

**Steven Silkunas**, Director of Business Development, Southeastern Pennsylvania Transportation Authority, Philadelphia, Pennsylvania, *Public Transportation Group Chair*

**Peter F. Swan**, Associate Professor of Logistics and Operations Management, Pennsylvania State, Harrisburg, Middletown, Pennsylvania, *Freight Systems Group Chair*

**James S. Thiel**, General Counsel, Wisconsin Department of Transportation, *Legal Resources Group Chair*

**Thomas H. Wakeman**, Research Professor, Stevens Institute of Technology, Hoboken, New Jersey, *Marine Group Chair*

**Johanna P. Zmud**, Director, Transportation, Space, and Technology Program, RAND Corporation, Arlington, Virginia, *Policy and Organization Group Chair*

Transportation Research Circular E-C172

# Roadside Safety Design and Devices

## *International Workshop*

July 17, 2012  
Milan, Italy

*Prepared by the*  
Roadside Safety Design Committee

*Editor*  
Rod Troutbeck  
Troutbeck & Associates

February 2013

Transportation Research Board  
500 Fifth Street, NW  
Washington, D.C.  
[www.TRB.org](http://www.TRB.org)

## TRANSPORTATION RESEARCH CIRCULAR E-C172

The **Transportation Research Board** is a unit of the National Research Council, a private, nonprofit institution that is the principal operating agency of the National Academy of Sciences and the National Academy of Engineering. Under a congressional charter granted to the National Academy of Sciences, the National Research Council provides scientific and technical advice to the government, the public, and the scientific and engineering communities.

The **Transportation Research Board** is distributing this Circular to make the information contained herein available for use by individual practitioners in state and local transportation agencies, researchers in academic institutions, and other members of the transportation research community. The information in this Circular was taken directly from the submissions of the authors. This document is not a report of the National Research Council or of the National Academy of Sciences.

### **Design and Construction Group**

Thomas J. Kazmierowski, *Chair*

### **Design Section**

Brian L. Ray, *Chair*

### **Roadside Safety Design Committee**

Richard B. Albin, *Chair*

Roger P. Bligh, *Vice Chair*

Ida Van Schalkwyk, *Secretary*

Dean C. Alberson  
Marco Anghileri  
Mark C. Ayton  
Micheal S. Bline  
Brian E. Chandler  
Bernie L. Clocksin  
Michael G. Dreznes  
John C. Durkos  
Gerrit A. Dyke  
Ronald K. Faller

Dean A. Focke  
Douglas J. Gabauer  
H. Clay Gabler  
Raphael H. Grzebieta  
Chad Heimbecker  
Don Louis Ivey  
John R. Jewell  
Francesca La Torre  
William P. Longstreet  
Dhafer Marzougui  
David K. Olson

Chuck A. Plaxico  
Malcolm H. Ray  
Francesca Russo  
Marc-Andre Seguin  
Ronald J. Seitz  
Barry D. Stephens  
Stephen M. Summers  
Gordon S. Thompson  
Gavin L. Williams  
William B. Wilson

Stephen Maher, *TRB Staff Representative*

Transportation Research Board  
500 Fifth Street, NW  
Washington, D.C.  
[www.TRB.org](http://www.TRB.org)

Javy Awan, Production Editor; Jennifer J. Weeks, Layout; Jennifer Corroero, Proofreading

## Preface

This circular is a record of a meeting hosted by the International Research Subcommittee of the Roadside Safety Design Committee in Milan, Italy, on July 17, 2012.

At the 91st Annual Meeting of the Transportation Research Board in January 2012 in Washington, D.C., the Roadside Safety Design Committee decided to hold an additional subcommittee meeting on the day preceding the I-Crash Conference. This would be the first-ever meeting of the International Research Subcommittee in Europe.

The I-Crash Conference attracts an audience with interests similar to those of the International Research Subcommittee. Subcommittee members could attend both functions, which were held at the same venue, the Passive Safety Laboratory of Politecnico di Milano, through the excellent efforts of Marco Anghileri.

The meeting was organized by Mike Dreznes and Rod Troutbeck, cochairs of the subcommittee. One hundred and eighteen delegates from 15 countries attended the Milan meeting of the International Research Subcommittee; Appendix B lists the attendees.

Presenters were asked to submit a summary of the presentations, which are included in this circular. The papers give a sense of what was discussed and should be useful for researchers and practitioners alike. Rod Troutbeck provided editorial guidance.

The meeting was a great success, and the attendees affirmed interest in conducting a similar meeting annually outside of North America.

Thanks go to the Roadside Safety Design Committee members—in particular to committee Chair Dick Albin; to the Politecnico di Milano—in particular, to Marco Anghileri; to all of the presenters; and finally to TRB Staff Representative Stephen Maher.

*—Rod Troutbeck and Mike Dreznes*  
*Cochairs, International Research Subcommittee of the Roadside Safety Design Committee*



## Contents

<b>Overview of Workshop Themes</b> .....	1
<i>Rod Troutbeck</i>	
<b>SESSION 1: ASSESSMENT PRACTICES</b>	
<b>MASH Compared to NCHRP 350</b> .....	7
<i>Mike Dreznes</i>	
<b>Can EN 1317 and NCHRP 350–MASH Be Used Interchangeably?</b> .....	11
<i>Jason Hubbell</i>	
<b>Current Status of EN 1317: U.S.–Europe Test Result Mutual Recognition</b> .....	22
<i>Marco Anghileri</i>	
<b>EN 1317 and CE Marking Versus National Regulations</b> .....	28
<i>Franz M. Muller</i>	
<b>Latest Update to the British Vehicle Restraint Assessment Process</b> .....	38
<i>Martin Heath</i>	
<b>SESSION 2: SAFE SYSTEMS</b>	
<b>Introduction (or Reintroduction) to the Safe System Approach</b> .....	51
<i>Raphael Grzebieta, Lori Mooren, and Soames Job</i>	
<b>Real-World Implications of the Safe System Approach</b> .....	59
<i>J. Marten Hiekmann</i>	
<b>Improving Roadside Design to Forgive Human Errors: Forgiving Roadside Design Guideline</b> .....	64
<i>Francesca La Torre</i>	
<b>END Turned-Down ENDS</b> .....	75
<i>Mike Dreznes</i>	
<b>END Turned-Down ENDS: How the United Kingdom Accomplished It</b> .....	82
<i>Steve Powell</i>	
<b>End Treatments of Safety Barriers: Best Practices and Challenges in Germany</b> .....	84
<i>Uwe Ellmers</i>	
<b>SESSION 3: BEST PRACTICES</b>	
<b>Best Practices and Strategies to Reduce Fatal or Serious Injury Crashes into Guardrail Posts by Motorcyclists: United Kingdom Experience</b> .....	89
<i>Gavin Williams</i>	
<b>Best Practices and Strategies to Reduce Fatal or Serious Injury Crashes into Guardrail Posts by Motorcyclists: Australian Experience</b> .....	93
<i>Raphael Grzebieta, Mike Bambach, and Andrew McIntosh</i>	
<b>Best Practices and Strategies to Reduce Fatal or Serious Injury Crashes into Obstacles and Road Equipment: Swedish Experience</b> .....	106
<i>Åke Löfqvist</i>	



<b>Best Practices and Strategies to Reduce Fatal or Serious Injury Crashes into Trees and Posts: Germany Experiences</b> .....	111
<i>Frank Brandt</i>	
<b>Best Practices and Strategies to Reduce Fatal or Serious Injury Crashes into Posts and Luminaire Supports: United States and Other International Experiences</b> .....	113
<i>Art Dinitz</i>	
<b>EN 12767: Passive Safety of Support Structures for Road Equipment</b> .....	116
<i>Carolien Willems</i>	

#### **SESSION 4: NEW ROAD SAFETY PRODUCTS**

<b>Development of a Redirective Crash Cushion to EN 1317-12</b> .....	123
<i>Pasquale Impero, Mauro Corsanici, and Luigi Grassia</i>	
<b>Development of N2–H1 Performance Level Guardrail: Crash Testing and Simulation</b> .....	126
<i>Ali Osman Atahan, Ayhan O. Yucel, and Orhan Guven</i>	
<b>Risks of Unprotected Median Drainage Ditches on Vehicle Stability</b> .....	135
<i>Ali Osman Atahan, Ayhan O. Yucel, and Orhan Guven</i>	
<b>How High-Friction Surfacing Treatments Combined with Other Safety Hardware Installations Save Lives Globally</b> .....	143
<i>John LeFante</i>	
<b>Development of a Recycled Substrate Material for Road Signs</b> .....	145
<i>Jason Hubbell and Liz Walker</i>	
<b>Very High-Precision “Weigh-in-Motion” Concept Based on Optical Fiber Technology</b> .....	149
<i>Michele Arturo Caponero and Andreas Demozzi</i>	
<b>The ABCs of Truck-Mounted Attenuators</b> .....	156
<i>Mike Dreznes</i>	
<b>Importance of an Appropriate Transition in a Longitudinal Barrier Design</b> .....	158
<i>Mike Dreznes</i>	
<b>Consideration of Wood Mechanical Properties Variation in Roadside Safety Barriers Performance Evaluation</b> .....	159
<i>Clément Goubel</i>	
<b>Workshop Outcomes and Concluding Remarks</b> .....	165
<i>Rod Troutbeck and Mike Dreznes</i>	

#### **APPENDICES**

<b>Appendix A. 2012 European Workshop on Roadside Safety Design: Agenda</b> .....	169
<b>Appendix B. Workshop Attendees</b> .....	172

## Overview of Workshop Themes

**ROD TROUTBECK**

*Troutbeck & Associates and  
Queensland University of Technology*

The International Research Subcommittee of the Roadside Safety Design Committee has more than 120 active members with an additional 251 friends from more than 30 countries in Europe, Middle East, Asia, and the Pacific.

Membership of the subcommittee requires regular attendance and participation. The meeting in Milan was conceived with the aim of encouraging participation from a different cohort that, due to the prevailing financial climate, would be unable to visit the United States.

There were 27 presentations grouped around four contemporary themes: assessment practices, safety systems, best practices, and other road safety products and issues. Each of these themes is described below

### ASSESSMENT PRACTICES

The first theme of the meeting was Assessment Practices. The desire for all products to be tested under the one set of requirements worldwide cannot happen now. In the early 1990s, attempts were made to have as many elements as possible common to both the European Normative (EN) 1317 and *NCHRP Report 350: Recommended Procedures for the Safety Performance Evaluation of Highway Features*. Hayes Ross at Texas Transportation Institute and Harry Taylor of the FHWA took an active involvement in this harmonization process. Their efforts have allowed for a more-informed discussion of the differences in the EN and the NCHRP 350 and AASHTO's *Manual for Assessing Safety Hardware* (MASH) testing requirements.

While there are these two testing regimes, products designed for either the U.S. or European markets do not immediately transfer to the other market. The first group of papers explains the differences between the EN 1317 and NCHRP 350–MASH testing requirements and solutions for further collaboration.

Papers presented independently by Mike Dreznes and Jason Hubbell discussed the differences between the testing requirements under EN 1317, NCHRP 350, and MASH. Dreznes explained that the products that met either one of these testing requirements should be used if there are no established testing requirements in a country. Marco Anghileri explained that many technical aspects of the EN 1317 test and the NCHRP 350–MASH testing were the same or very similar. Testing houses in either the United States or Europe could undertake testing to both standards. This aspect will further the mutual collaboration and understanding of all involved.

Having a process for testing road safety products is one thing, but there is also a need to establish when and where safety barriers (vehicle restraint systems) should be used. Franz Müller highlighted the considerable differences in the types of barrier that would be employed in similar situations in different European countries. Martin Heath's paper explained that following the Selby incident where a SUV and a trailer went behind a longitudinal barrier and onto a train track that finally caused two trains to collide, the Highway Agency reviewed their standards for

the installation of road safety restraint systems. Their current systems are based on risk assessment practices. It often takes one such critical accident for policies and practices to change.

## **SAFE SYSTEMS**

The second theme was Safe Systems. For a number of years we have had the notion that the roadside should be forgiving if a driver were to leave the traveled way. Death on our road systems should not be considered normal. Death and serious injuries should be reduced as far as possible and we should embrace Vision Zero, which came from Scandinavia and northern Europe. To do so we should be more cognizant of the need to restrict the forces on drivers and passengers to be less than those likely to cause injury and death. To do so requires efforts of not only the road engineer, but also others. In Australia, we have the concept of shared responsibility between the vehicle manufactures, road engineers, and the road users. In our National Road Safety Strategy, we state our aim to have safe roads, safe vehicles, safe drivers, and safe speeds. Raphael Grzebeita's paper explains the concept of safe systems in which an error by a driver should not result in a serious injury or death. In this paper, Grzebeita emphasized that technology will assist in developing safe systems, but in the end, the speeds of vehicles may need to be better managed and reduced.

All authorities need to locate safety barriers where they will be most effective. Barriers are a hazard themselves and should only be used if they reduce the risk to motorists. Marten Hiekman's paper promoted the need for consistent passive road safety across Europe by ensuring roadsides are effectively planned by installing appropriate safety barrier systems and by maintaining barriers correctly. Fransesca La Torre's paper continued this theme by describing the IRDES project that developed a uniform guide for assessing the safety of the roadside. It makes reference to barriers, terminals, rumble strips, forgiving roadside furniture, and different road cross sections.

Risk is reduced when engineers use hardware that has been tested against the EN 1317, NCHRP 350, MASH, or other recognized requirements in the roadside. But the level of testing should be commensurate with expected vehicle speeds. The test speeds do not have to be the same as those posted or the 85th percentile operating speeds that Mak and Bligh (2002) had researched. What is important is that the test speed for the barrier or road safety device is appropriate for the road or motorway. The paper by Dreznes explained an awareness program he started and has promoted through the subcommittee that we should end the use of noncrashworthy terminals. These included terminals that were obviously unsafe, like fish tail end or blunt concrete ends, but also terminals that were tested at a much lower speed than the road's operating conditions.

Steven Powell outlined how the U.K.'s Highway Agency has started to eliminate noncrashworthy terminals by establishing a priority list and replacing those that presented the greatest risk first. Finally in the last paper for this theme, Ellmers' paper described the German practice for end treatments. He indicated that the road authorities in Germany did not feel that the ramped terminals were a significant safety concern given that they are installed to the specifications in their guidelines.

## BEST PRACTICES

Part of the International Research Subcommittee's role is to identify and explain international best practices used in different countries. In the third session, best practices were explained, noting that one solution may not suit all practices in all countries. Of particular interest was the hardware and processes used to reduce death and serious injuries of motorcyclists after a collision into a safety barrier. Like almost all other structures, safety barriers are hazardous to motorcyclists.

Williams' paper described the characteristics of riders and road sections involved in fatal crashes in the United Kingdom. He indicated that in a high proportion of crashes, riders were not sliding along the pavement before colliding with barriers. This is not covered in the CEN (European Committee of Standardization) document TC 1317, Part 8. In the paper by Grzebieta, similar rider and road characteristics of fatal motorcycle crashes were provided from Australia and the United States. He identified that injuries to the thoracic region were the most prevalent, followed by head injuries. Further work is need worldwide to establish risk assessment processes to identify the appropriate locations to install motorcycle protection systems.

Löfqvist's paper explained that the most common fatal accident type has changed from head-on to single run-off accidents following the installation of 3,000 km of median barriers on rural roads. Swedish authorities are designing safer roadsides by using rumble strips and flatter slopes and concentrating on the likely impacts after vehicles have left the road at a small angle ( $6^\circ$  at 110 km/h). Impact with trees is a problem common to all countries. Brandt identified in his paper that crashes into trees constituted nearly 20% of all fatal crashes in Germany. This paper describes a stiffened barrier systems used close to trees.

Street lighting poles and signposts represent a class of hazards that are engineered into the roadside. The paper of Dinitz explained that using omnidirectional breakaway supports can help eliminate injuries caused when motorists collide with these hazards. Willems' paper described EN 12767: Passive Safety of Support Structures for Road Equipment, which classifies these structures as being high-energy, low-energy, or non-energy absorbing. She described a pole that meets the requirements of a high energy-absorbing pole.

## NEW ROAD SAFETY PRODUCTS

Under this theme, authors have described new products and treatments that may help to improve road safety. Grassia described a redirective crash cushion developed in Italy using steel honeycomb elements and successfully tested at 80 km/h. Atahan described a lightweight N2-H1 performance-level guardrail that has successfully met the requirements of EN 1317-1 and -2 with N2-W3-A and H1-W4-A performance levels when breakaway bolts were used between post and rail. Atahan showed the results of an evaluation of different median ditch configurations and barrier installations.

It is better to keep vehicles on the road rather than trying to protect drivers if the vehicle collides with a hazard. LeFante introduced a concept to using a high-friction surface treatment to increase the coefficient of friction to reduce the number of run-off-the-road crashes. Traffic signs give motorists important guidance, which may cause them to adopt a safe speed. Hubbell describes a recycled plastic sheeting that can be used for signs. For many countries, this has the advantage of using waste material while at the same time it eliminating signs being stolen for

scrap metal. Overweight trucks cause pavements to deteriorate more quickly and increase the impact loads on safety barriers. Demozzi described a weigh-in-motion system to identify these vehicles.

Work zone safety is vital. Dreznes explained the importance of using truck mounted attenuators (TMAs) on stopped or slow-moving vehicles in work zones. TMAs protect the motorists and the truck driver. Dreznes argued that contractors should be encouraged to use TMAs. Transitions between barrier systems of different stiffness are important parts of barrier systems in some countries including the United States and Australia; however, this is not the case in all countries. Dreznes described the importance of a transition and indicated that MASH has testing requirements and that EN 2317-4 is under formal enquiry for testing transitions.

Simulation models are useful in extending the understanding of a barrier system. Goubel described a validation method for simulation models. The process used a number of attributes in the validation of a timber-faced barrier.

## CONCLUDING REMARKS

The papers make reference to a number of assessment procedures (EN 1317-1 and subsequent parts, NCHRP 350, and MASH) and often without quoting the reference. These references are at the very heart of the Roadside Safety Design Committee and so it is understood that they will not be referenced each time they are used. Appropriate references are given below.

The papers in this circular provide a comprehensive view of road safety engineering in Europe, United States, and Australia. The papers have value beyond the meeting in Milan; they should have value to practitioners worldwide.

## REFERENCE

Mak, K. K., and R. P. Bligh. Assessment of NCHRP Report 350 Test Vehicles. In *Transportation Research Record: Journal of the Transportation Research Board*, No. 1797, Transportation Research Board of the National Academies, Washington, D.C., 2002, pp. 38-43.

## KEY RESOURCES

AASHTO. *Manual for Assessing Safety Hardware*. American Association of State Highway and Transportation Officials, Washington, D.C., 2009.

EN 1317. Parts Are from the European Committee for Standardisation, Central Secretariat, Rue de Stassart 36, B-1050, Brussels, Belgium.

Ross, H. E., Jr., D. L. Sicking, R. A. Zimmer, and J. D. Michie. *NCHRP Report 350: Recommended Procedures for the Safety Performance Evaluation of Highway Features*. TRB, National Research Council, Washington, D.C., 1993.

SESSION 1

**Assessment Practices**



## SESSION 1: ASSESSMENT PRACTICES

**MASH Compared to NCHRP 350****MIKE DREZNES***International Road Federation*

**M**any people are confused regarding the status of *NCHRP 350: Recommended Procedures for the Safety Performance Evaluation of Highway Features* and AASHTO's *Manual for Assessing Safety Hardware* (MASH). Much of this confusion is due to the implementation procedure for MASH compared to the implementation process used for NCHRP 350.

The purpose of MASH, like NCHRP 350, is to provide criteria and standards for evaluating new safety hardware devices. Neither MASH nor NCHRP 350 provides guidelines for the design of roadside safety hardware. This information is contained within the AASHTO *Roadside Design Guide*. MASH and NCHRP 350 represent uniform guidelines used to conduct full-scale crash tests for permanent and temporary highway safety features along with recommended evaluation criteria to access the test results. Products addressed in NCHRP 350 and MASH include longitudinal barriers, transitions, end terminals, crash cushions, breakaway–yielding supports, truck-mounted attenuators, and work zone traffic control devices. The crash performance is judged on structural adequacy, occupant risk, and vehicle trajectory.

Researchers try to ensure the test vehicle range represents about 85% of the passenger vehicle fleet. In the United States, vehicles weighing about 820 kg (1,800 lbs), which was the lightweight vehicle under NCHRP 350, were very difficult to find in 2009 when MASH was written. In addition many of the pickup trucks used as test vehicles in NCHRP 350 had increased in weight and height. These vehicle changes helped to drive the development of the MASH crash testing requirements.

The major differences between NCHRP 350 and MASH can be summarized as follows:

- Test vehicles are updated to reflect the 85th percentile of the United States' passenger vehicle fleet.
- Impact condition criteria were modified to correct inconsistencies and to identify needed conditions.
- Evaluation criteria were modified to correct subjective criteria and to better define other criteria.

Additional details showing the differences between NCHRP 350 and MASH are shown below.

**CHANGES IN TEST MATRICES**

- The small car impact angle for longitudinal barrier testing is increased from 20° to 25° to match the impact angle used with light truck testing.



- The impact speed for the single-unit truck used for TL-4 testing is increased from 80 km/h to 90 km/h to better distinguish the TL-4 impact severity levels from TL-3.
- The impact angle for length-of-need testing of terminals and crash cushions is increased from 20° to 25° to match that for longitudinal barriers.
- The impact angle for oblique end impacts for gating terminals and crash cushions is reduced from 15° to 5°.
- For small vehicle tests on cable barrier, the target impact point must be at midspan to evaluate the potential for under ride, while the target impact point for all other test vehicles shall be limited to 30 cm (1 ft) upstream of the post for all test conditions.
- Length-of-need tests with the pickup truck are required to meet occupant risk criteria.
- A head-on test with the midsize car is added for staged impact attenuation systems.
- The barrier mounting height is recommended to be set at the maximum for small car tests and at the minimum for pickup truck tests.
- The critical impact point for the small car terminal test is defined as the point where the terminal behavior changes from redirection to gating.
- The critical impact point for reverse direction impacts requires testing at the transition from backup structure to crash cushion.
- Two optional transportation management area (TMA) NCHRP 350 tests are mandatory in MASH and the manufacturer determines the minimum and maximum host truck weights, which will determine how the TMA is used in the field. Test 53 is run with the lightest-weight host vehicle and all other tests with the heaviest recommended host vehicle. The host vehicle is not up against a concrete wall during the MASH light car head-on test like it was in NCHRP 350.
- Variable message signs and arrow board trailers are added to the TMA crash test matrix.
- A pickup truck test is added to tests of support structures and work zone traffic control devices.
- Longitudinal channelizing devices are added as a category and a test matrix is recommended.
- Event data recorded and airbag deployment data to be collected on test vehicles.

## **CHANGES IN TEST INSTALLATIONS**

- Performance-based specifications for soil are added to the existing material-based specifications to help ensure consistency in soil strength.
- The lateral width requirement for fill material is eliminated.
- Any rail element splices that are used in the field are required to be installed in the impact region during testing.
- Cable tension is required to be set to the value recommended for 100°F.
- More-detailed documentation of components used in the test installation is required.
- Minimum installation length requirements for longitudinal barriers are specified more clearly.

## CHANGES IN TEST VEHICLES

- The sizes and weights of test vehicles are increased to reflect the increase in U.S. passenger vehicle fleet size:
  - The 820C test vehicle is replaced by the 1100C;
  - The 2000P test vehicle is replaced by the 2270P;
  - The single-unit truck mass is increased from 8,000 to 9,000 kg; and
  - The light truck test vehicle must have a minimum center of gravity height of 71 cm (28 in.).
- The option for using passenger car test vehicles older than 6 years is removed.
- Truck box attachments on test vehicles are required to meet published guidelines.
- External vehicle crush must be documented using National Automotive Sampling System procedures.
  - A new crushable nose needs to be developed for use on surrogate test vehicles.
  - TMA designers are required to select maximum and minimum support truck weight ratings.

## CHANGES IN EVALUATION CRITERIA

- Windshield damage evaluation uses quantitative, instead of qualitative, criteria.
- Windshield damage criteria are applied to permanent support structures in addition to work zone traffic control devices.
  - The occupant compartment damage evaluation uses quantitative, instead of qualitative, criteria.
    - All evaluation criteria will be pass or fail, eliminating the “marginal pass.”
    - All longitudinal barrier tests are required to meet flail space criteria.
    - Maximum roll and pitch angles are set at 75°.
    - The subjective criteria for evaluating exit conditions are eliminated; reporting the exit box evaluation criterion is required.
  - Documentation on vehicle rebound in crash cushion tests is required.

## CHANGES IN TEST DOCUMENTATION

- Computer-assisted drafting drawings of the test device and test installation are required.
- Additional documentation of the test and evaluation results is required.

When NCHRP 350 was introduced in 1993, road authorities in the United States were able to continue to procure NCHRP 230 products only for 5 years until November 1, 1998. Road authorities were required to purchase products that meet NCHRP 350 for new projects after November 1, 1998. Installed products that did not meet NCHRP 350 could only be used until the end of their normal product life cycle. FHWA did require that existing highway safety hardware

that was accepted under NCHRP Report 350 be upgraded with NCHRP 350 products during reconstruction projects, during 3R projects, or when the system was damaged beyond repair.

MASH was introduced in 2009 and any revised or new highway safety products that were under development before October 15, 2009, when MASH was introduced were allowed to continue to be tested with the NCHRP 350 criteria. However, as of January 1, 2011, the FHWA no longer reviewed nor accepted requests for eligibility letters for revised or new products unless they met the MASH criteria. A significant number of road safety products tested to NCHRP 350 were submitted to FHWA in December 2010 to get them in under the MASH deadline of January 1, 2011.

MASH is an AASHTO document. NCHRP 350 was a FHWA document, and this variance will have a significant effect on the MASH implementation. The major difference between NCHRP 350 and MASH implementation is that road authorities will be allowed to continue to purchase NCHRP 350 products for the foreseeable future. FHWA will not require them to use MASH-only product like FHWA did with NCHRP 350. Each state is allowed to make its own decision regarding the testing criteria that road safety products will be required to meet in its own jurisdiction. Most, if not all states currently are allowing the use of NCHRP 350 and MASH products, and this is the likely scenario for the near future. Most road authorities agree that MASH hardware should be used when available, but there are no requirements for the replacement of existing NCHRP 350 hardware. FHWA does encourage road authorities to upgrade existing highway safety hardware that has not been accepted under MASH or NCHRP Report 350 to either MASH or NCHRP 350 during reconstruction projects, during 3R projects, or when the system is damaged beyond repair.

Very few products have been tested to MASH and limited product development is underway, since it is likely that the MASH products will be more expensive than the NCHRP 350 products due to the more stringent MASH testing requirements. A road authority that allows both products to be used will most likely choose the lower-priced NCHRP 350-qualified product and this scenario makes it unfeasible for a manufacturer to develop the more expensive MASH product. Another problem occurs if only one product in a product category meets MASH. A road authority will be reluctant to specify the MASH product if they know this will create a monopoly situation. For all of these reasons, it is reasonable and logical to assume that the NCHRP 350 road safety products will be used for many years in the United States.

While the United States is requiring that NCHRP 350 or MASH products be used and the European Community countries are requiring that EN 1317 products be used in their jurisdictions, countries outside the United States and Europe that are developing their own road safety standards should consider allowing the use of products that meet NCHRP 350, MASH, or EN 1317. Specifying just one criterion will limit the number of available products, thereby reducing competition and possibly driving up prices.

In March 2011, the International Road Federation endorsed the resolution by a global group of road safety experts who met at the TRB's Roadside Safety Design Subcommittee on International Research Activities AFB20(2) on January 14, 2008. This resolution recommends that

road authorities in all countries should only specify roadside safety hardware, i.e., longitudinal safety barriers, crash cushions, terminals and transitions that has met either NCHRP 350 or EN 1317 criteria (or their updates).

## SESSION 1: ASSESSMENT PRACTICES

**Can EN 1317 and NCHRP 350–MASH Be Used Interchangeably?****JASON HUBBELL***Atlanticum Bridge Corp., Italy*

The purpose, or if you will, the goal of this paper is to stimulate discussion on comparing the *NCHRP 350: Recommended Procedures for the Safety Performance Evaluation of Highway Features* and AASHTO's *Manual for Assessing Safety Hardware (MASH)* standards to the European Normative (EN) 1317 standard with the desire that such discussions lead to a formal comparison. Doing so would create a reference for countries around the world allowing them to safely integrate roadway safety products into one highway system utilizing diverse standards. Apart from potentially creating safer roadways and highways such a reference guide could potentially open up other markets to one standard or another, driving competition and ingenuity.

For the record, this paper is referencing only NCHRP 350, MASH, and EN 1317 parts 1, 2, and 4. There will be no footnotes or bibliography. Where a specific reference is required for a table or section of any of those standards it will be directly referenced in the body of this paper.

In 2008, through this committee (AFB20), a global group of roadside experts recommended that road authorities utilize EN 1317, NCHRP 350, or both standards, and their updates, for developing and approving the use of roadside safety products. Why utilize both standards instead of choosing one or the other? In a word: competition. One of the drawbacks to only accepting products tested to one standard or another is the reduction in available products to the end users. Both EN 1317 and NCHRP 350–MASH are well-designed regulations that have been effective in stimulating the development of roadside safety products.

A potential issue for those countries using both NCHRP 350–MASH and EN 1317 is how to safely integrate products tested according to different standards on one roadway network? Can you transition from a H1 to a TL-4? Is it safe to use a TL-2 crash cushion on a roadway with a posted speed limit of 130 km/h? Is a TL-3 end terminal equal to a P4 end terminal? What is needed is a framework to build a comprehensive comparison of the two standards. Having a comprehensive, detailed comparison would allow road safety engineers to confidently build safe roadways utilizing products tested to both EN 1317 and NCHRP 350–MASH.

So where does one start when attempting to analyze and compare these three standards? With energy. Ultimately, the business of roadside safety is a business of energy management. Yes, a final, complete comparison of the standards should take into consideration more than just the impact energies. A review of the vehicle types, centers of gravity, measurement techniques, vehicle occupant risk, and many other aspects of crash testing would be necessary for a complete comparison of the standards. That said, an energy comparison is a good launching point to begin the comparison of the standards. To keep this paper brief, only the heavy vehicle tests for longitudinal barriers and the highest class of end terminals will be reviewed.

It should be noted, that this is going to be a comparison of NCHRP 350 and MASH to EN 1317. Why include MASH and NCHRP 350? Many countries in the world are choosing, for the moment, to continue to use NCHRP 350 instead of its update MASH. That is not to say that a country accepting NCHRP 350 will not accept MASH. As of the writing of this paper, there are not yet many products available to the markets which have been tested to MASH. Accepting

only MASH would limit the possible products available to the markets. So let's begin by comparing nominal energy levels of longitudinal barriers and transitions as outlined by NCHRP 350, MASH, and EN 1317. Something the three standards have in common is that a test level for both transitions and longitudinal barriers require a heavy and light vehicle test. The heavy vehicle tests demonstrate a barrier's or transition's ability to manage what is considered the high end of the lateral energy levels for a specific test level and evaluate the systems strength in containing the heavy vehicle. Light vehicle tests demonstrate the vehicle occupant risk or essentially what effect the deceleration and redirection has on the vehicle occupant.

In Figures 1 and 2 the nominal lateral impact energies for longitudinal barriers are outlined from data directly from the standards themselves. For the NCHRP 350, nominal impact kinetic energies ( $KE$ ) for longitudinal barriers are found on Table 3.7. MASH nominal impact  $KE$ s for longitudinal barriers are found on Table 2-2. For EN 1317, nominal impact  $KE$ s for longitudinal barriers are found in the EN 1317-1 document on Table B.1.

Figures 1 and 2 make clear that with respect to all three standards there is some close correlation for the first three test levels. For the test levels that follow these first three it would appear, at first glance, that there is a divergence. However, with a little more in-depth review of the standards a more defined understanding of how the standards matchup is achieved.

It should be noted that, with regard to the test level's high set  $KE$ , this comparison is giving a nod to MASH and NCHRP 350. MASH states that "...for most full-scale crash tests, excessive impact speed and angles do not improve the likelihood of a successful test. Therefore, excessive speed and angles are not considered to be a cause for failing these tests, provided all impact performance evaluation criteria are met. The exceptions to this general rule are the low-speed tests..."

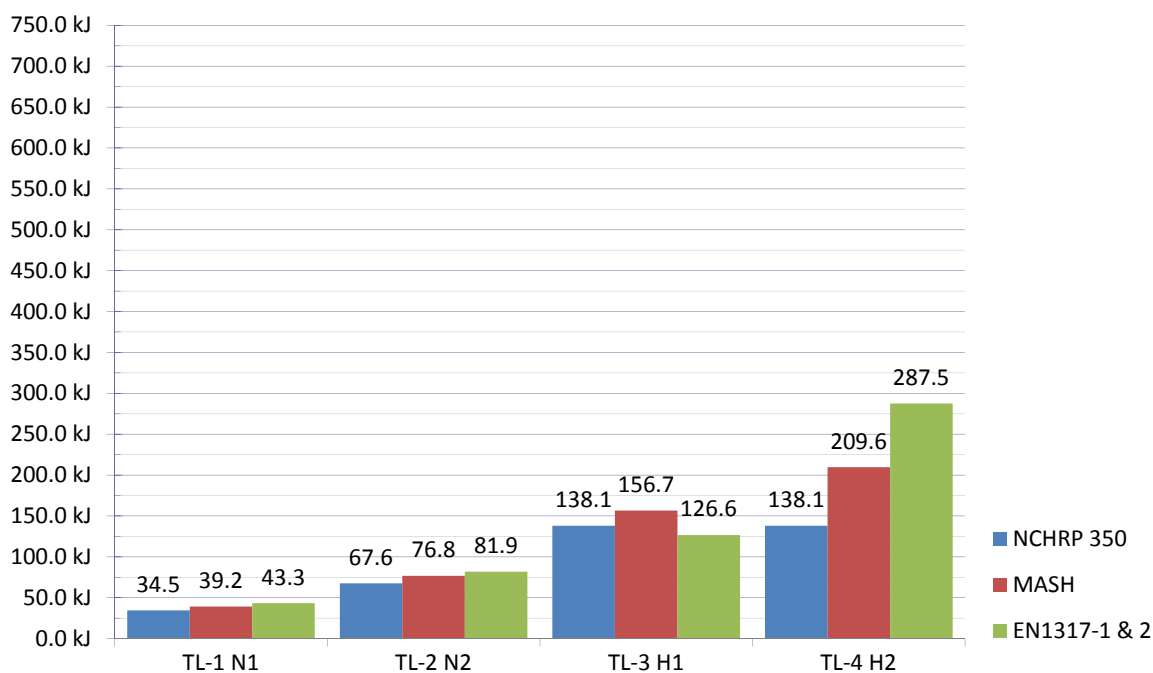

**FIGURE 1** Nominal  $KE$  for longitudinal barriers for NCHRP 350, MASH, and EN 1317, utilizing vehicles with a mass of less than 16 tonnes.

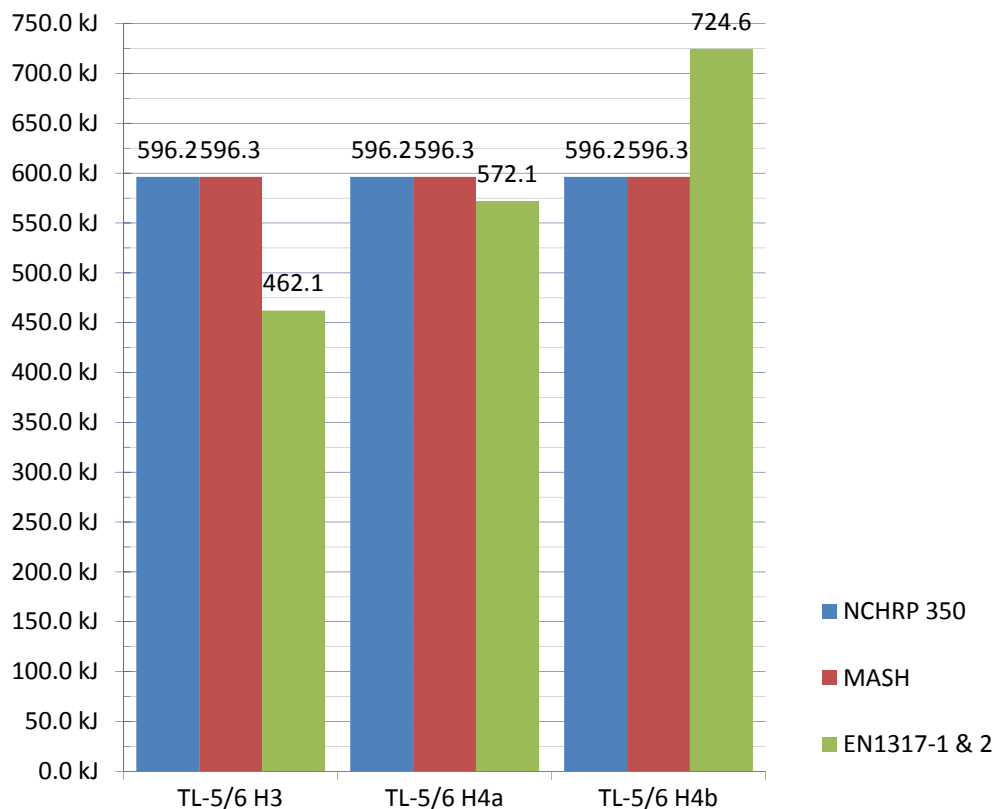

**FIGURE 2 Nominal *KE* for longitudinal barriers for NCHRP 350, MASH, and EN 1317, utilizing a vehicle with a mass of greater than 16 tonnes.**

Figures 3 and 4 adjust the nominal energy levels to upper or lower tolerances for energy according to the standards. NCHRP 350 lists the tolerances for longitudinal barrier's *KE* directly on Table 3.7. MASH, however, is a little more detailed in how it defines the tolerances. Section 2.1.2 outlines what is considered to be the method for calculating tolerance. Based on the review of Section 2.1.2 a formula can be created for upper and lower tolerances. For the upper tolerance the following formula can be used:  $\text{Nominal } KE(1.08)$ . The lower tolerance can be calculated by:  $\text{Nominal } KE(0.92)$ .

To arrive at the upper and lower tolerances of EN 1317 a few more steps must be taken. Under EN 1317-2, Section 5.5 details the proper method to define the tolerances. It is this author's understanding from a review of the EN 1317 standard that to properly evaluate the tolerances it is not simply an increase of mass, velocity, and impact angle. According to Part 2, Section 5.5, to calculate the upper tolerance for impact energy the impact angle may be increased by  $1.5^\circ$  but velocity must decrease by 5%. The inverse is true for calculating a lower tolerance. Velocity is increased by 2% while impact angle is decreased by  $1^\circ$ . Mass is not specifically mentioned in Part 2, Section 5.5. However, the tolerances for vehicle mass are found in Part 1, Table 1: Vehicle Specifications. From Table 1, the upper and lower tolerances for a specific vehicle's mass can be found. From both the Table 1 in Part 1 and the description in Section 5.5 found in Part 2, the following formulas are derived:

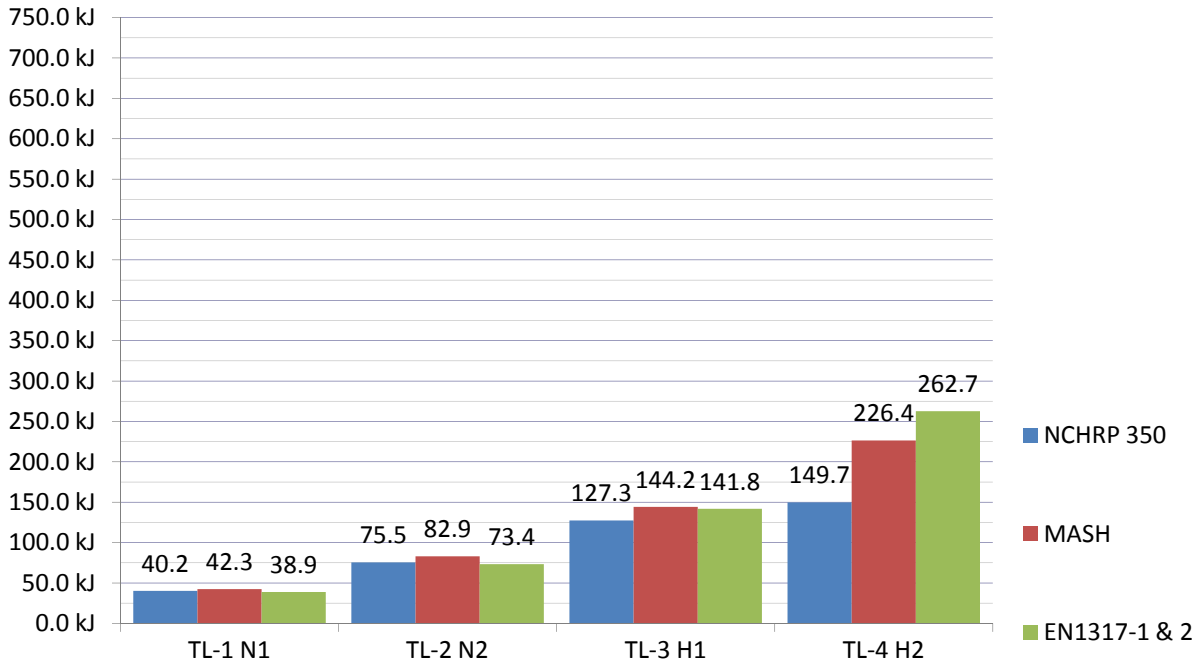

**FIGURE 3 Adjusted *KE* to tolerances for longitudinal barriers for NCHRP 350, MASH, and EN 1317, utilizing a vehicle with a mass less than 16 tonnes.**

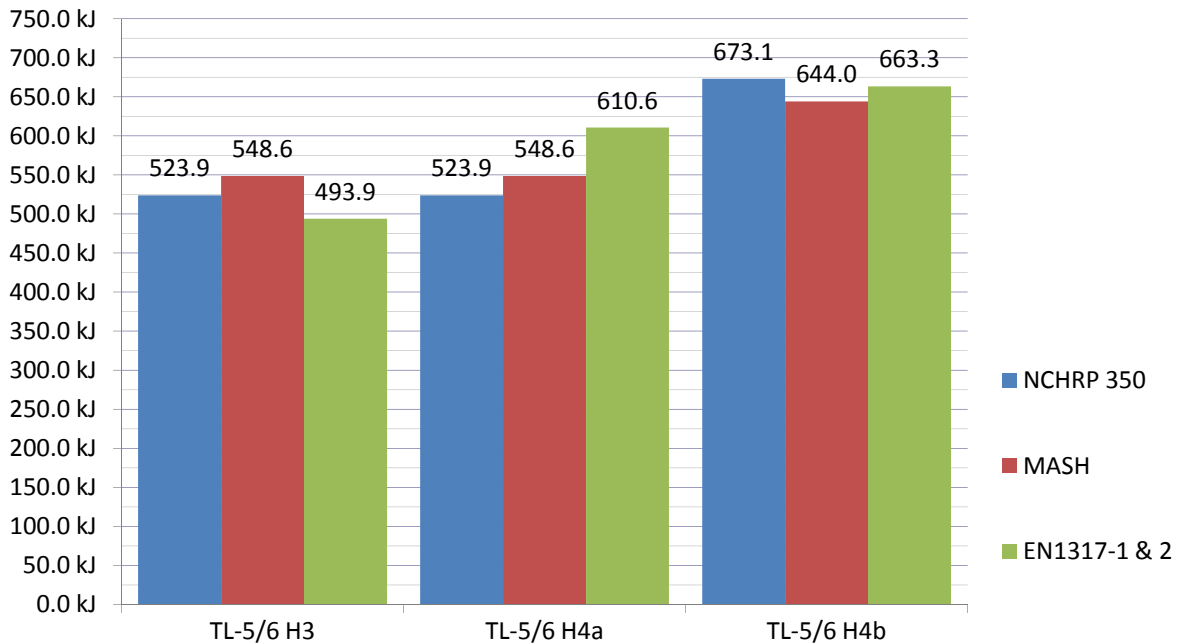

**FIGURE 4 Adjusted *KE* to tolerances for longitudinal barriers for NCHRP 350, MASH, and EN 1317, utilizing a vehicle with a mass greater than 16 tonnes.**

$$\text{Upper tolerance} = (M + MT_u)/2 [(V 0.95) (\sin\theta + 1.5^\circ)^2]$$

$MT_u$  = upper vehicle mass found on Table 1 of EN 1317-1

$$\text{Lower tolerance} = (M + MT_l)/2 [(V 1.02) (\sin\theta - 1^\circ)^2]$$

$MT_l$  = lower vehicle mass found on Table 1 of EN 1317-1

### TL-1 AND N1

- N1 lower tolerance and TL-1 (NCHRP 350–MASH) upper tolerance have some crossover.
- The N1 nominal is higher than the TL-1 (NCHRP 350 and MASH) upper  $KE$  tolerance.
- With regard to this test set of the NCHRP 350 and MASH TL-1 it may be reasonable to conclude that a TL-1 system in certain cases could be used as, or with, a N1 system.
- As the lower tolerance for N1 energies falls near the top of the upper tolerances of the TL-1 energies it can be reasonably used as TL-1 according to both MASH and NCHRP 350.

### TL-2 AND N2

- N2 lower tolerance and TL-2 (NCHRP 350 and MASH) upper tolerance some crossover.
- The N2 nominal is higher than the TL-2 (NCHRP 350 and MASH) nominal.
- With regard to this test set of the TL-2 it may be reasonable to conclude that a TL-2 system in certain cases could be used as, or with, a N2 system.
- As the lower tolerance for N2 energies falls near the top of the upper tolerances of the TL-2 energies it can be reasonably used as TL-2.

### TL-3 AND H1

- The graph shows that the TL-3 nominal  $KE$  is superior to the H1 nominal  $KE$ .
- As can be seen from Figure 3 the NCHRP 350 TL-3 lower  $KE$  tolerance crosses over the H1 upper  $KE$  tolerance.
- The MASH lower tolerance does not any crossover with the H1 upper  $KE$  tolerance.
- With regard to this test set of the H1 it may be reasonable to conclude that a H1 system in certain cases could be used as, or with, a NCHRP 350 TL-3 system but could not ever be used as, or with, a MASH TL-3 system.
- As the lower tolerances for both NCHRP 350 and MASH TL-3 energies superior, as is the case for MASH, or within the upper tolerances of the H1 energies, as is the case with NCHRP 350, systems from both standards can be reasonably used as H1.



## TL-4 AND H2

- The graph shows a large divergence between NCHRP 350–MASH and EN 1317.
- Figure 3 shows that the H2 nominal *KE* is significantly superior to the TL-4 nominal *KE*.
  - As can be seen from Figure 3 that the upper *KE* tolerances of NCHRP 350 and MASH TL-4 do not have any crossover with lower *KE* tolerances for H2.
    - With regard to the kinetic energies it would not be reasonable to conclude that TL-4 systems from neither NCHRP 350 nor MASH could be used as, or with, a H2 system.
    - As the lower *KE* tolerance of the H2 is significantly superior to the upper *KE* tolerance of the TL-3 it could be reasonable to assume that all H2 systems could manage TL4 energies.

## TL-5, TL-6, AND H3

- TL-5 and TL-6 are grouped together because from a *KE* standpoint they are identical. The difference between the two tests, apart from the centers of gravity, is the TL-5 is a “dry” cargo (or van cargo) while the TL-6 is a “wet” cargo (or tanker cargo).
  - Both NCHRP 350 and MASH TL-5/6 nominal *KE* are superior to the EN 1317 H3 nominal *KE*.
    - As can be seen from Figure 4, the lower *KE* tolerances of NCHRP 350 and MASH TL-5 do not have any crossover with upper *KE* tolerances for H3.
      - With regard to the kinetic energies it would not be reasonable to conclude that H3 systems could be used as, or with, a TL-5/6 system from neither NCHRP 350 nor MASH.
      - As the lower *KE* tolerance of the TL-5 for both NCHRP 350 and MASH is significantly superior to the upper *KE* tolerance of the H3 it could be reasonable to assume that all TL-5 systems could manage H3 energies.

## TL-5, TL-6, AND H4A

- As can be seen from the graph the lower *KE* tolerances of NCHRP 350 and MASH TL-5 and TL-6 do crossover with upper *KE* tolerances for EN 1317 H4a.
  - Both the NCHRP 350 TL-5 and TL-6 upper *KE* tolerance (673.1kJ) and MASH TL-5 and TL-6 upper *KE* tolerance (644.0kJ) exceeds the upper *KE* tolerance of H4a (610.6kJ).
    - It could be reasonable to conclude that a NCHRP 350 and MASH TL-5 and TL-6 system can be used with and as an H4a system. This is directly due to the fact that the lower *KE* tolerance of the NCHRP 350 and MASH TL-5 and TL-6 is higher than the lower *KE* tolerance of the H4a and because the NCHRP 350 TL-5 upper *KE* tolerance is higher than the upper *KE* tolerance of the H4a.
      - This means that for the EN 1317 H4a system in certain cases it can be used as a NCHRP 350 and MASH TL-5 and TL-6.

## TL-5, TL-6, AND H4B

- The H4b nominal *KE* tolerance is dramatically superior to the nominal *KE* tolerance of NCHRP 350 and MASH at TL-5.
- There is some crossover between NCHRP 350 TL-5 upper *KE* tolerance and H4b lower *KE* tolerance.
- Provided that a NCHRP 350 TL-5 system's actual *KE* is 663.3kJ, or higher, then it could be reasonable to conclude that it could be used as, or with, an H4b system.
- A MASH TL-5 system, however, could not be used as, or with, an EN 1317 H4b system. This is due to the fact that the lower *KE* tolerance of the H4b is superior to the upper *KE* tolerance of the MASH TL-5.
- An EN 1317 H4b system can be used as, or with, either a NCHRP 350 TL-5 or a MASH TL-5.

That was long and wordy. So to make it simpler these tables will help (Tables 1 through 7). To use the tables correctly start on top and move down the column to the appropriate row.

**TABLE 1 TL-1 and N1**

TL-1 and N1		Tested to		
		NCHRP 350	MASH	EN 1317
Accepted to	NCHRP 350	—	—	R
	MASH	—	—	R
	EN 1317	CC	CC	—

NOTE: R = reasonable expectation of utilization; NR = no reasonable expectation of utilization; PR = possible reasonable expectation of utilization; and CC = case by case.

**TABLE 2 TL-2 and N2**

TL-2 and N2		Tested to		
		NCHRP 350	MASH	EN 1317
Accepted to	NCHRP 350	—	—	R
	MASH	—	—	R
	EN 1317	CC	CC	—

NOTE: See Table 1.

**TABLE 3 TL-3 and H1**

TL-3 and H1		Tested to		
		NCHRP 350	MASH	EN 1317
Accepted to	NCHRP 350	—	—	CC
	MASH	—	—	NR
	EN 1317	R	R	—

NOTE: See Table 1.

**TABLE 4 TL-4 and H2**

TL-1 and N1		Tested to		
		NCHRP 350	MASH	EN 1317
Accepted to	NCHRP 350	—	—	R
	MASH	—	—	R
	EN 1317	NR	NR	—

NOTE: See Table 1.

**TABLE 5 TL-5, TL-6, and H3**

TL-5, TL-6, and H3		Tested to		
		NCHRP 350	MASH	EN 1317
Accepted to	NCHRP 350	—	—	NR
	MASH	—	—	NR
	EN 1317	R	R	—

NOTE: See Table 1.

**TABLE 6 TL-5, TL-6, and H4a**

TL-5, TL-6, and H4a		Tested to		
		NCHRP 350	MASH	EN 1317
Accepted to	NCHRP 350	—	—	CC
	MASH	—	—	CC
	EN 1317	R	R	—

NOTE: See Table 1.

**TABLE 7 TL-5, TL-6, and H4b**

TL-5, TL-6, and H4b		Tested to		
		NCHRP 350	MASH	EN 1317
Accepted to	NCHRP 350	—	—	R
	MASH	—	—	R
	EN 1317	CC	NR	—

NOTE: See Table 1.

Next is a comparison of end terminals nominal energies as outlined by NCHRP 350, MASH, and EN 1317. Unlike with longitudinal barriers, end terminals go through at least four tests, depending on the standard that is being tested to, and from different approaches.

For this discussion, only the EN 1317 P4, NCHRP 350 TL-3, and MASH TL-3 will be compared. Specifically, the comparison is of redirective gating end terminals.

At the time of this presentation it is understood that ENV 1317-4 has been reviewed and a proposal to separate end terminals from part 4 and create a part 7 is under review and is scheduled for acceptance in 2014. The reason part 7 has not been used for this presentation is because while part 4 is currently only a “pre-norm” it is what member states are currently working with to evaluate end terminals. Therefore, only ENV 1317-4 is used in this review.

The first graph shown is of the nominal impact energies which are outlined by the standards themselves. For the NCHRP 350 nominal impact kinetic energies are found on Table 3.7. However, it should be noted that for the 3-30 test the nominal impact *KE* listed on Table 3.7 is a calculation which does not include the “dummy” mass. To bring the comparison on the same level as EN 1317-4 the nominal *KE* for test 3-30 is calculated with a vehicle mass of 895kg. MASH nominal impact kinetic energies are found on Table 2-3.

ENV 1317-4 nominal impact kinetic energies are not found in the document. So a calculation must be performed to arrive at what can be assumed as the expected nominal impact *KE*. Using the theoretical mass, velocity, and impact angle, which is found in Table 1, and with the formula for *KE* a result can be achieved to an approximate nominal lateral impact *KE*. The formula is:

$$KE = M/2(V\sin\theta)^2$$

When dealing with head on impacts of end terminals 90° should be used in the formula for the angle of impact, not 0°.

It should also be noted that ENV 1317-4 calls for four tests to be performed for the P4 test set. NCHRP 350 calls for up to seven tests to be performed for the TL-3 test set. MASH calls for up to eight tests to be performed for the TL-3 test set. As this presentation is attempting to compare NCHRP 350 and MASH with EN 1317 there is a need to review neither all seven NCHRP 350 tests nor all eight MASH tests that may be required. Four tests were selected from NCHRP 350 and MASH, which were the most similar to the ENV 1317-4 tests.

The tests which were selected from NCHRP 350 were 3-30, 3-31, 3-35, and 3-39 while 3-30, 3-31, 3-35, and 3-37 were selected from MASH. These tests were selected as they are, with respect to vehicle mass, velocity, impact angle, and approach as similar as possible to ENV 1317-4.

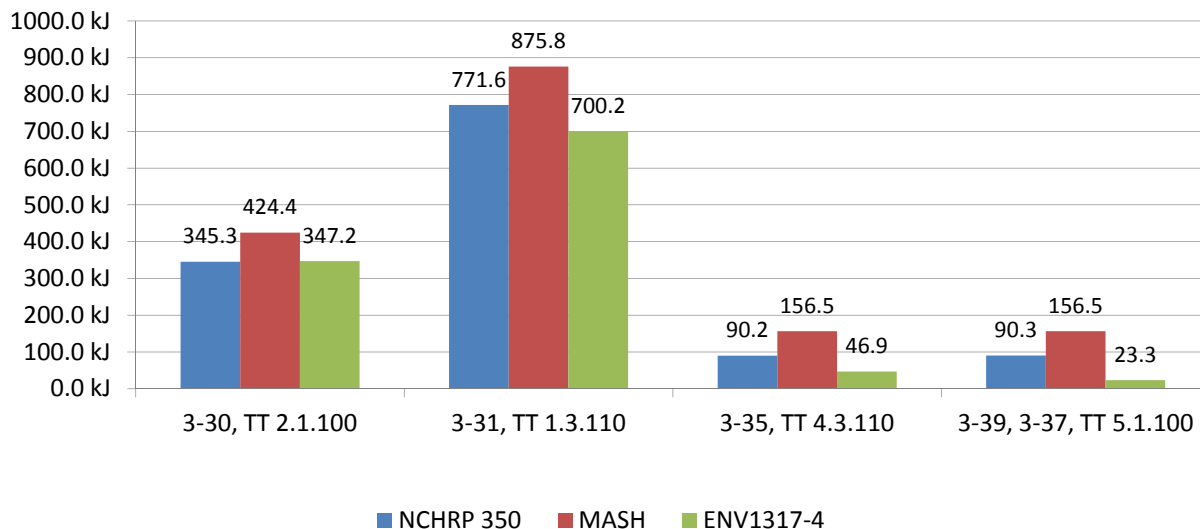

**FIGURE 5 Nominal *KE* for redirective end terminals for NCHRP 350, MASH, and ENV 1317-4.**

Figure 5 shows that with respect to nominal impact *KE*, MASH testing is more severe in each test. NCHRP 350 is more severe than ENV 1317-4 in three of the four tests. But in the test where the ENV 1317-4 *KE* is more severe, the difference is less than 1%. NCHRP 350 lists the tolerances directly in Table 3.7. MASH, however, is a little more detailed in how it defines the tolerances. Section 2.1.2 outlines what is considered to be the method for calculating tolerance. Based on the review of Section 2.1.2 a formula can be created for upper and lower tolerances. For the upper tolerance the following formula can be used: Nominal *KE* (1.08). The lower tolerance can be calculated by: Nominal *KE* (0.92)

As before with longitudinal barriers, determining end terminal *KE* tolerances is not found on a chart or table. So as with longitudinal barriers the formula to determine end terminal *KE* must be created based on what information that is outlined by Parts 1 and 2. The only exception to these formulas is the head on impacts. As a direct head on, 90 (or 0), is the maximum potential angle for an upper tolerance then the +1.5 would not be part of the equation.

$$\begin{aligned} \text{Upper tolerance} &= (M + MT_u)/2 [(V 0.95) (\sin\theta + 1.5^\circ)^2] \\ MT_u &= \text{upper vehicle mass found on Table 1 of EN 1317-1} \\ \text{Lower tolerance} &= (M + MT_l)/2 [(V 1.02) (\sin\theta - 1^\circ)^2] \\ MT_l &= \text{lower vehicle mass found on Table 1 of EN 1317-1} \end{aligned}$$

As the nominal impact *KEs* of MASH were all significantly higher than ENV 1317, only the lower tolerances of the impact *KEs* were used. NCHRP 350 test 3-30 was the only test that had nominal impact *KEs* which were less severe than the ENV 1317-4 test. Therefore, only for test 3-30 was an upper tolerance used (Figure 6).

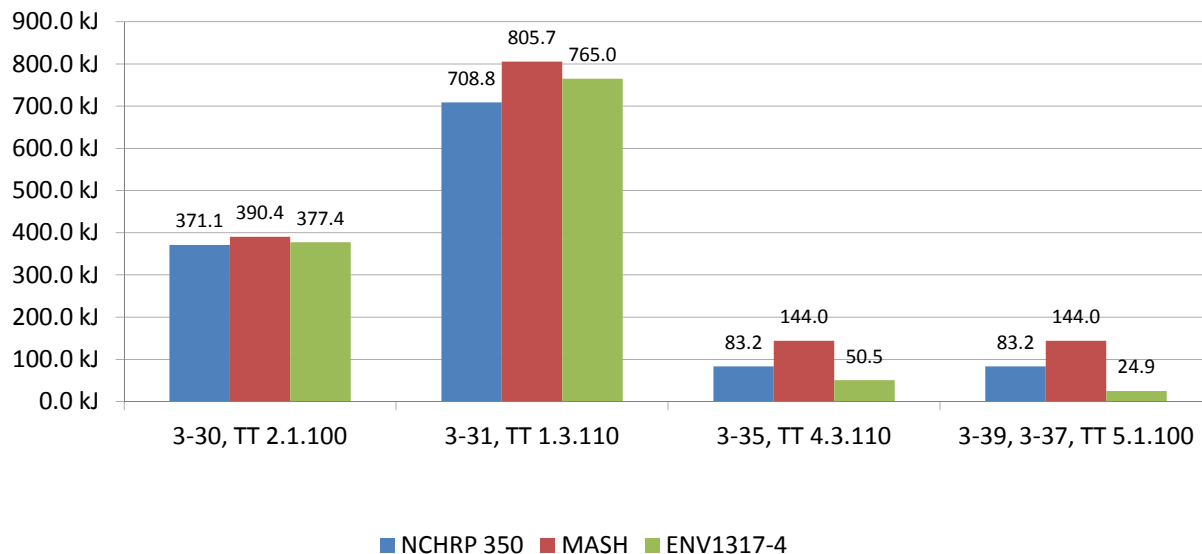

**FIGURE 6 Adjusted *KE* to tolerances for redirective end terminals for NCHRP 350, MASH, and ENV 1317-4.**

Upon review it can be seen that for both the nominal impact *KE* and the upper tolerance impact *KE*, all tests for MASH and NCHRP 350 TL-3 have either some crossover or are more severe.

It can be reasonably concluded that redirective gating end terminals tested to TL-3 according NCHRP 350 and MASH could be used as P4 redirective gating end terminal according to ENV 1317-4. However, this comparison does not show that ENV 1317-4 P4 redirective gating end terminal could be used as a MASH or NCHRP 350 TL-3 redirective gating end terminal.

In conclusion, this paper has shown to some small extent how NCHRP 350 and MASH can compare to EN 1317 when reviewing kinetic impact energy. A much more-thorough analysis would need to be done to show exactly how these standards might align to one another. A thorough analysis would include an analysis of several other factors such as but not limited to vehicle types, centers of gravity, vehicle occupant risk, and vehicle behavior post impact. This is not to suggest that EN 1317 products should be used in the United States or that NCHRP 350–MASH products should be used in the European Union. Although many countries in the world have chosen to use either NCHRP 350, MASH, or EN 1317, the rest of the world is installing NCHRP 350-tested products on the same road with EN 1317-tested products and, without a doubt, at times there are mistakes being made. Having a well-thought-out guide to assist roadside engineers evaluate correctly whether they can use a TL-3 product with a H1 product will save lives.

## SESSION 1: ASSESSMENT PRACTICES

## Current Status of EN 1317 and U.S.–Europe Test Result Mutual Recognition

**MARCO ANGHILERI**  
*Politecnico di Milano*

The supporting parts of European Normative (EN) 1317 and AASHTO's *Manual for Assessing Safety Hardware* (MASH) are equivalent documents produced in Europe and the United States for assessing the safety performance of roadside hardware. While it is understood that there are some differences there are also many similarities. Often industry asks whether they can sell products tested to *NCHRP 350: Recommended Procedures for the Safety Performance Evaluation of Highway Features* or MASH in Europe, while others ask whether products tested to EN 1317 can be sold in the United States? It is my view that the short answer is no and this paper will provide the reasons and in what sense a recognition is possible.

Universally, it is acknowledged that road safety is improved if the risk of an accident is reduced and if the potential injuries from each accident is also reduced. Effective roadside hardware results in less injury when a vehicle collides with it.

The concepts of using effective roadside safety hardware (safety barriers or vehicle restraint systems) to improve road safety are the same everywhere. EN 1317 and MASH have the same focus of setting assessment procedures and limits for different parameters that provide safe and responsible hardware.

### ASSESSMENT PROCESSES

Broadly, EN 1317 and MASH assess the performance of road restraint systems with a similar fashion. In both cases, full-scale tests are conducted with representative vehicles, in representative impact speeds and angles on generally flat terrain. In both cases the output is an evaluation of the deformation of the road restraint system, the trajectory of the impacting vehicle, and the likely risk of injuries for occupants or road users.

But there are significant differences in the detail. There are differences with the vehicles used in the testing, the precise impact conditions, the evaluation of the restraint system performance, and the method of evaluating the risk of injury. These differences will be described below.

### Typical Vehicles

Both EN 1317 and MASH have a smaller vehicle and a larger vehicle. For EN 1317 the vehicle masses are 900 and 1,500 kg, the NCHRP 350 vehicles are 820 and 2,000 kg, and these have been increased in MASH to 1,100 and 2,270 kg, respectively. These differences are shown in [Figure 1](#) for the smaller vehicles and in [Figure 2](#) for the larger vehicles.

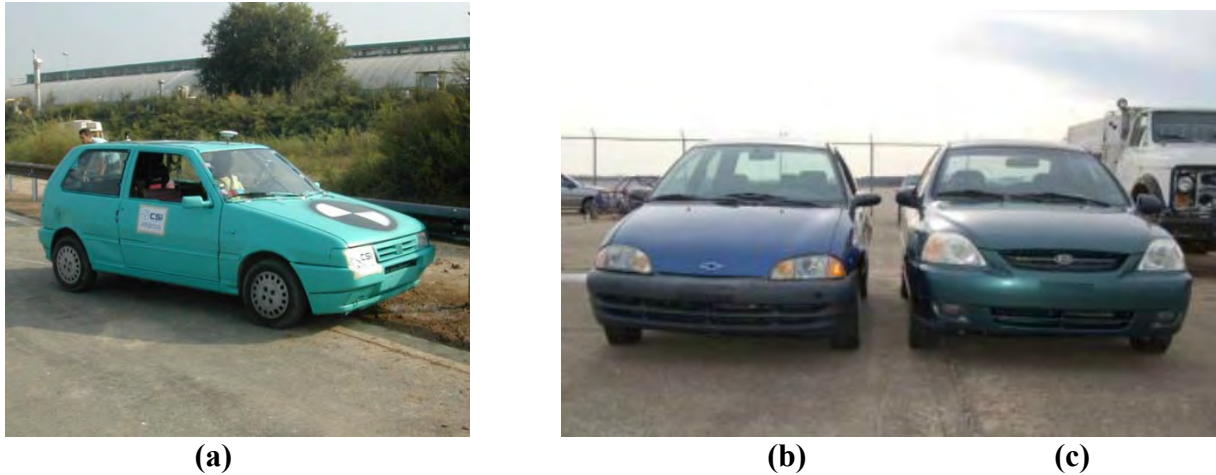

**FIGURE 1** Small car test vehicles: (a) EN 1317, (b) NCHRP 350, and (c) MASH.



**FIGURE 2** Larger test vehicles: (a) EN 1317, (b) NCHRP 350, and (c) MASH.

### Impact Conditions

The impact speed and angles differ between the different testing standards. This can be expressed as the impact severity for each test containment level as shown in [Figure 3](#).

### Occupant Injury Measures

EN 1317 uses an Accident Severity Index (ASI) to define three classes. For classification A, the ASI is less than 1.0; for classification the ASI is between 1 and 1.4; and for classification C, the ASI is between 1.4 and 1.9, although this is only used for barriers.

The occupant protection is further defined through the THIV (Theoretical Head Impact Velocity). For barriers, EN 1317 requires the THIV to be less than 33 km/h and for the frontal tests for crash cushions and terminal it is to be less than 44 km/h.



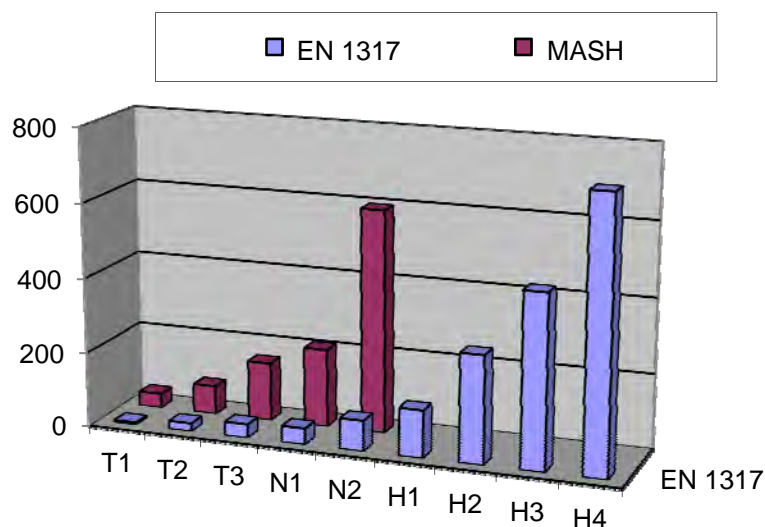

**FIGURE 3 Impact severity for different test containment level.**

MASH specifies an occupant impact velocity (OIV) to be preferable less than 30 ft/s or 32.7 km/h and to have a maximum of 40 ft/s or 43.9 km/h. These values are similar to those from EN 1317, but with a different calculation procedure.

MASH also specifies occupant ride-down acceleration (ORA) measured subsequent to the OIV values. The ORA values should be preferably less than 15 g and with a maximum of 20.49 g.

Both OIV (in MASH) and THIV (in EN 1317) are similar concepts. They represent the theoretical impact speed of a body as it moves outside the flail space. This is a representation of the head impacting the inside the vehicle. The big difference is that OIV uses velocity components, THIV uses the resultant. Figure 4 is a representation of the flail space model used in EN 1317-1.

ORA (in MASH) is similar to PHD, which was used to represent the maximum acceleration that the theoretical head is suffering after the first impact (after THIV or OIV measures). ORA independently use acceleration components while PHD uses resultant acceleration. PHD has been deleted from EN 1317 because was considered to be not a reliable measure. The concept is correct, but the measurement is too sensitive to oscillations in the acceleration trace.

ASI is completely different from OIV and ORA and it is not a measure required by MASH, although MASH does encourage testing agencies to calculate the ASI.

The method to evaluate restraint system performances is completely different in EN 1317 and MASH. Will a system successfully tested with MASH pass EN 1317 requirements? I believe safety barriers probably will, but crash cushions will probably not. Differences in the assessment reflect different traffic, roads design and alignments, vehicle fleets, and the occupant impact severity evaluation.

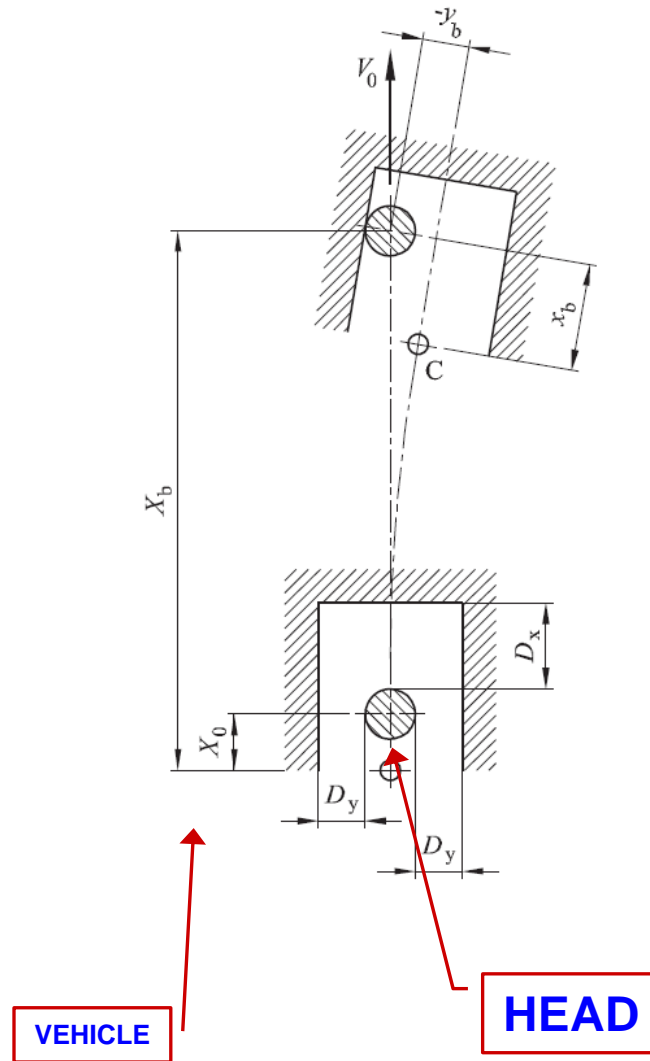

FIGURE 4 Flail space model in EN 1317-1.

## INSTALLING A RESTRAINT SYSTEM ON THE ROAD

Under EN 1317 the process of installing a vehicle restraint system on the road depends on whether standard (or part) is harmonized or not. The flow chart in [Figure 5](#) indicates the steps. If the EN 1317 part is harmonized then the test agency will notify the appropriate body in the member state and the product can have CE (European Committee of Standardization) markings attached. Examples are EN 1317-2 for safety barriers and EN 1317-3 for crash cushions. If the safety device is not a “constructed product” like a temporary barrier or a transportation management area (TMA), then it cannot have CE markings. In addition if the standard has not been voted to be harmonized, for instance EN 1317-8 for motorcyclist protection systems, then again it cannot have CE markings.

## MUTUAL RECOGNITION

Possible mutual recognition agreement (MRA) between the European community and the United States relating to road safety equipment are described in the Transatlantic Economic Partnership between Europe and the United States.

There are three further possible means for mutual recognition from the European Commission Directorate General III industry. These include the following:

1. Mutual recognition of test data only. This option can be seen as offering some, although limited, trade facilitation.
2. Mutual recognition of test data, certificates, inspections, or approvals, i.e. “conformity assessment.” This option is in line with the existing MRA and can be said to offer more comprehensive market access.
3. Mutual recognition of conformity assessment and technical requirements. This option involves, not the harmonization, but the recognition of the equivalence of each other’s technical requirements. In more operational terms, this would mean that a product manufactured in Europe according to the European Union (EU) legislation and standards would be recognized by the United States as fulfilling their requirements. This option would of course require a comparison of the EU and U.S. provisions and standards in order to determine whether they can give assurance of fulfilling each other’s regulatory objectives.

Given the differences between 1317 and MASH, option 3 is impossible to achieve, but options 1 and 2 could be achieved.

Multilateral agreements (MLA) are agreements signed between the EA (European Cooperation for Accreditation) body members to recognize the equivalence, reliability, and acceptance of accredited certifications, inspections, calibration certificates, and test reports across Europe. The MLA eliminates the need for suppliers of products or services to be certified in each country where they sell their products or services, and therefore provides a means for goods and services to cross boundaries in Europe and throughout the world. It delivers confidence in the service supplied by accredited laboratories and inspection and certification bodies, thereby providing the framework for goods and services to cross borders in Europe and throughout the world, acting as a “passport for trade.”

The International Laboratory Accreditation Cooperation (ILAC) in Washington, D.C., is an international cooperation of laboratory and inspection accreditation bodies. The EA MLA is recognized at international level by ILAC and International Accreditation Forum (IAF); a test report or certificate accredited by an EA MLA signatory can be also recognized by the signatories of the ILAC and IAF multilateral agreements, the EA MLA acting then as an international passport to trade. By resolution No. 14, passed at the 22nd meeting of the General Assembly in November 2008, EA recognizes the technical equivalence between results issued by conformity assessment bodies accredited under the ILAC or IAF MRA–MLA.

All the European and U.S. accreditation authorities are listed by ILAC. It is now considered that, given that the ILAC arrangement is in place, the next crucial step is for governments and industries to take advantage of this arrangement. Governments can use it to further develop or enhance trade agreements. Another important step that is already underway

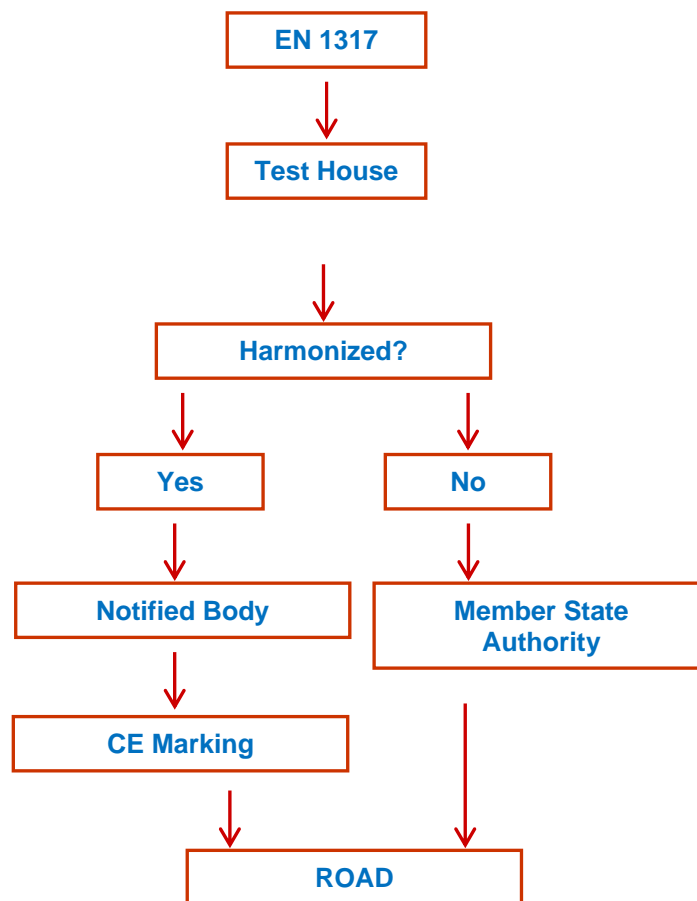

**FIGURE 5** Flowchart for the use of a vehicle restraint system on the road.

involves government acceptance of the results from accredited laboratories. Regulatory agencies around the world are beginning to accept the results from testing and calibration laboratories that are accredited by accreditation bodies, which are signatories to the ILAC arrangement, without direct government review, including results from laboratories in other countries. In summary, the results from European test houses could be accepted in the United States and vice versa.

## CONCLUSIONS

1. EN 1317 and MASH are too different to be used as a single standard, but the technology to perform the tests, acquire data, and evaluate performances is the same.
2. EN TMA standard probably will accept NCHRP 350 or MASH tests. Will MASH accept EN 1317 European tests?
3. Test house accreditation is a passport to export results between United States and Europe.
4. This passport could be accepted and tests performed, for example, in the United States according to EN 1317 could be accepted also for CE markings.

## SESSION 1: ASSESSMENT PRACTICES

**EN 1317 and CE Marking Versus National Regulations****FRANZ M. MÜLLER***Road Safety Consultant, Italy***ROAD RULES**

The rules to be used on roads for traffic safety are not well known at all levels, and now in Europe we speak a lot about European Committee for Standardisation (CEN) standards. The standards come from European Parliament and Commission decisions which mandate that the work have CE (Conformité Européenne) marking on products, which is necessary when circulating in Europe and legally sold on the market.

Some national authorities were quite happy to replace former homologations with the new marking, but this regulation refers just to products and producers. It is mainly a declaration in an agreed form of some main performances by a producer which bears the responsibility of what he declares, even if the procedure may involve third parties like “notified” certification bodies.

It is worth remembering that it all started in 1985, when a decision of the European Council, called New Approach, requested that some essential requirements in matter of safety, determined by the European Commission, should be harmonized and written into standards to be respected by products willing to circulate within the European Union (EU). The producer becomes responsible for the product and declares conformity to requirements through CE marking. Actuation came through the Construction Products Directive (CPD, CEE 89/106), which gave the floor to numerous standards and was recently superseded by CPR (Construction Products Regulation), which will become fully operative by July 1, 2013.

In case of road restraint systems, the harmonized standard is European Normative (EN) 1317-5, which is the general approach to requirements and products evaluation, and the specific Annex ZA, which dictates the rules for CE marking.

At this time, all 27 member countries of the EU apply this standard and the consequence is a fairly good leveling of the main performances of the safety products.

However, this is just half of the problem. Still needed to be defined is what to install where, i.e., the installation rules, which until up to now were strictly defined by each country. Some countries have already had rules for several years, others have produced them recently, and others still do not have anything specific. The result is a discrepancy on the market and on the safety level on roads of different countries.

Following are some examples from main European countries.

**Italy**

Following a procedure started in 1992, the last provision is the Ministerial Decree 2367 of 2004, which rules through Technical Instructions all interventions on new roads or renovations where design speed is above 70 km/h, defines homologation procedures accepting EN 1317 supporting parts as testing procedures. Types of systems, as well as zones to protect, are identified such as verge in certain conditions, central reserve, and obstacles.

**TABLE 1 Type of Traffic**

<b>Tipo di traffico (Type of Traffic)</b>	<b>TGM (Average Daily Traffic)</b>	<b>% Veicoli con massa &gt; 3.5 tonne (% Vehicles with a mass &gt; 3.5 tonnes)</b>
I	≤1,000	Qualsiasi [any]
I	>1,000	≤5
II	>1,000	5 < n ≤ 15
III	>1,000	>15

For the choice of a system, there is a link to the average daily traffic (TGM) in terms of heavy vehicles (>3.5 tonnes) percentage (Table 1).

The following tables indicate minimum classes to be used for barriers according to the type of the road and the type of traffic.

The case of longitudinal barriers is shown in Table 2, which has in the first column the type of road, then the type of traffic, the central reserve, the verge, and the bridge situations.

In a similar way, crash cushions are regulated, different classes of which are listed as a function of the posted speed (Table 3).

The following sections mainly give particular indications to the application designer, which is responsible for the adequacy of the protection.

Due to the modifications introduced by the CE marking and to the experience coming from road data, presently there is an activity to modify the decree and the technical instructions. The new version is expected by the end of this year.

**TABLE 2 Longitudinal Barriers (Translation in Brackets)**

<b>Tipo di Strada (Type of Road)</b>	<b>Tipo di Traffico (Type of Traffic)</b>	<b>Barriera Spartitraffico (Safety Barriers)</b>	<b>Barriera Bordo Laterale (Longitudinal Barriers)</b>	<b>Barriera Bordo Ponte (Bridge Parapets)</b>
Autostrade (A) e strade extraurbane principali (B) [Highways and principal interurban roads (B)]	I, II, III	H2, H3, H3–H4	H1, H2, H2–H3 (2)	H2, H3, H3–H4
Strade extraurbane secondary (C) e Strade urbane di scorrimento (D) [Secondary interurban roads (C) and sub-suburban roads (D)]	I	H1	N2	H2
	II	H2	H1	H2
	III	H2	H2	H3
Strade urbane di quartiere (E) e strade locali (F). [Urban roads (E) and local roads (F)]	I	N2	N1	H2
	II	H1	N2	H2
	III	H1	H1	H2

**TABLE 3 Crash Cushions (Translation in Brackets)**

<b>Velocità Imposta nel sito da Proteggere (Speed Condition at the Site to be Protected)</b>	<b>Classe Degli Attenuatori (Class of Attenuator)</b>
Con velocità $v > 130$ km/h (With speeds $v > 130$ km/h)	100
Con velocità $90 \leq v < 130$ km/h (With speeds $90 \leq v < 130$ km/h)	80
Con velocità $v < 90$ km/h (With speeds $v < 90$ km/h)	50

## France

The reference document is the ministerial order Arrêté of 2009, which gives rules for the use of CE-marked products (safety barriers and crash cushions) on roads with posted speed greater than 70 km/h and fixes the minimum performances to ask according to the road types.

At first, it requires an evaluation of the road, the accident probability, and the advantage of installing a protection.

The minimum requirements for barriers in different conditions (plain, bridges, etc.) are well described, considering also particulars and the need to verify the compatibility of  $W$  with the situation. Often the minimum required is containment class N1 or N2 and it seems to be lower than what is previously seen for Italy.

For crash cushions, it refers to the posted speed, as seen in [Figure 1](#), Art. 7, where on the left are the posted speeds and on the right the cushion levels.

**Art. 7.** – Les performances de retenue exigées en ce qui concerne les atténuateurs de chocs sont fonction de la limitation de vitesse en vigueur sur la section où l'atténuateur de choc est installé (Performance restraint requirements for attenuators are a function of the speed limit in force on the section where the impact attenuator is installed):

- Section limitée à 70 km/h; niveau minimum de retenue 80/1 (section limited to 70 km/h; minimum restraint level 80/1);
- Section limitée à 90 km/h; niveau minimum de retenue 80 (section limited to 90 km/h; minimum restraint level 80);
- Section limitée à 110 km/h; niveau minimum de retenue 100 (section limited to 110 km/h; minimum restraint level 100/1);
- Section limitée à 130 km/h; niveau minimum de retenue 110 (section limited to 130 km/h; minimum restraint level 110/1).

**FIGURE 1 Article 7 from French standard Arrêté  
(with an English translation in brackets).**

## United Kingdom

TD 19/06 is a chapter of the design manual for road and bridges to be used in the road design for roads having speed over 50 mph (80 km/h) and is based on risk assessment, showing measures to mitigate it. This is done through a standard (Figure 2) covering Requirements for Road Restraint Systems (RRS) and an Excel tool (RRRAP) where risk can be calculated and performances determined.

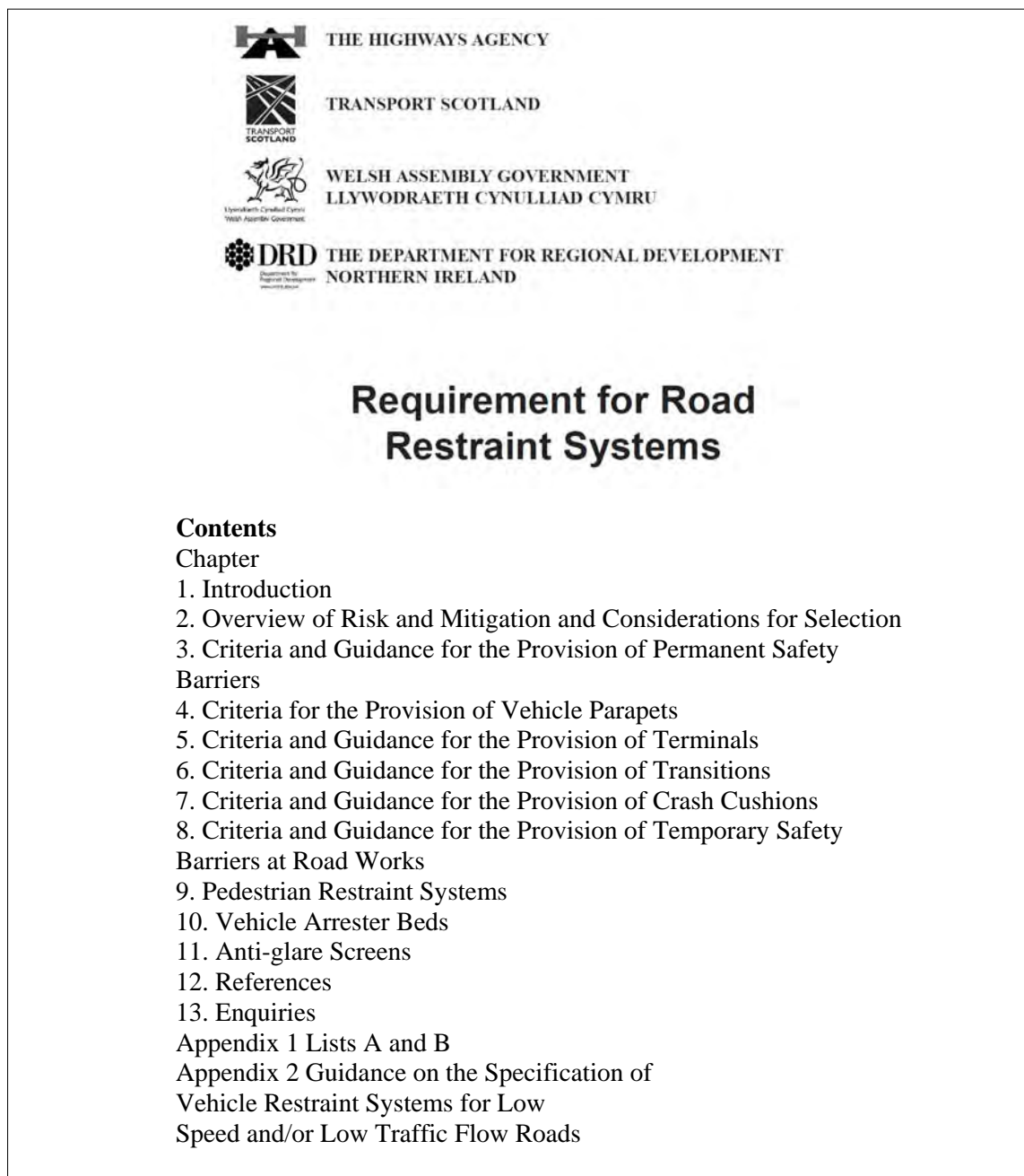

**FIGURE 2 U.K. Standard TD 19/06 RRS front page and contents.**



The risk approach is interesting and is justified in this way (Figure 3). This risk theory-based RRS has been developed to:

- Introduce risk analysis into the design and assessment process;
- Make the risk assessments that are implicit within standards more transparent;
- Provide computer software to enable a risk assessment process to be carried out following recommended design practices to ensure consistency in design appraisal;
  - Enable designers to carry out site-specific risk assessments within the design process in order to select appropriate design parameters for all types of works;
  - Provide a framework to support designers in making optimal design choices at specific sites.

It is also fully explained together with mitigation considerations in Chapter 2 and it introduces a cost–benefit analysis.

1. Identify the hazards;
2. Assess the level of risk at each; and
3. Decide on and implement appropriate action to eliminate, minimize, or control the hazards and mitigate the risk.

Beside referring to EN 1317 for product characteristics and evaluation of conformity, it gives instructions for the selection of the fences (e.g., safety barriers) based on containment, impact severity, working width, visibility, and other features, with specific provisions for verges and central reserves. Examples of general use containment levels for barriers are shown in Figure 4.

A large section then covers the positioning of the restraint systems. Figure 5 shows a nosing example.

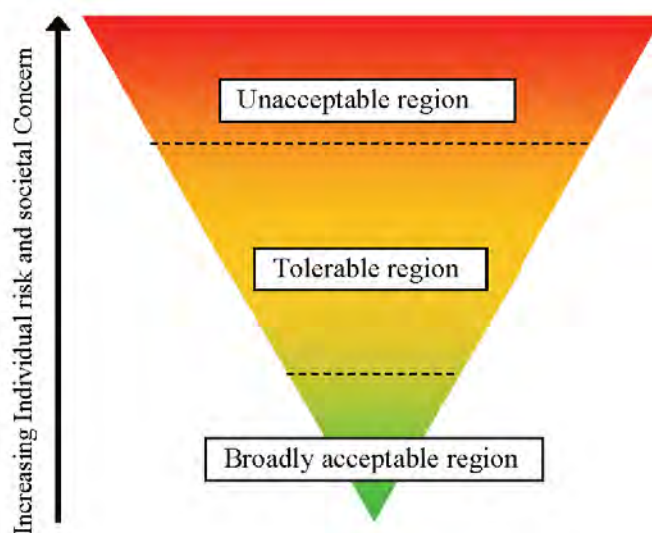

**FIGURE 3 Risk regions.**

<p>3.4 The containment levels requirements for safety barrier are:</p> <p><b>Permanent Deformable and Rigid Safety Barriers:</b></p> <p>(i) <b>On roads with a speed limit of 50 mph or more:</b></p> <p>(a) Normal Containment Level = N2</p> <p>(b) Higher Containment Level = H1 or H2</p> <p>(c) Very High Containment Level = H4a</p> <p>(ii) <b>On roads with a speed limit of less than 50 mph:</b></p> <p>(a) Normal Containment Level = N1</p> <p>3.5 Where the Road Restraint Risk Assessment Process (RRRAP) or the requirements below indicate a containment level that is higher than the minimum, as indicated in Paragraphs 3.4(i)(a) or (ii)(a), is required, the higher containment level must be specified.</p>
---

**FIGURE 4 Containment levels for barriers.**

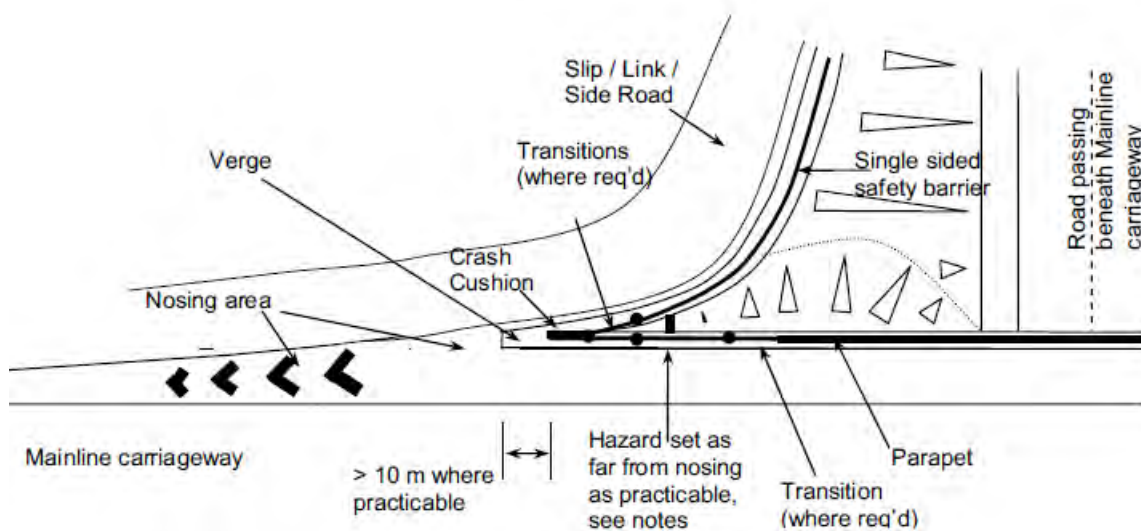

**FIGURE 5 Safety barrier layout and factors to consider at a nosing area.**

Other sections provide guidance for terminals, transitions, crash cushions and also temporary barriers.

## Germany

*Guidelines for Passive Protection on Roads Using Vehicle Restraint Systems* (RPS 2007) covers all permanent products, applicable to new constructions or improvements.

General requirements specify where to install products included in EN 1317, such as barriers, terminals, transitions, crash cushions (redirective only), giving minimum classes, as shown in [Table 5](#) for crash cushions as a function of posted speed

A following chapter is dedicated to criteria for use and application-specific requirements, where, after evaluation of the likelihood of leaving the road, single systems are classified and explained also with considerations on critical distances and diagrams.

A new document, TLP-FRS (Instructions for Test and Delivery of RRS), presented as a draft in 2012, is more detailed and specifies characteristics like materials, minimum height, color, detached parts, labeling, etc., and requires all documentation in German language.

## Spain

Like other countries, the Orden Circular 28/2009 specifies criteria for the application of metal barriers. Risk criteria are also shown through examples; a table considering the type of road, position, slope, to assess risk as function of the distance of an obstacle ([Figure 6](#), abstract; [Tables 6](#) and [7](#)). Other considerations are made about selection of products ([Figure 7](#)), end sections, geometric position, special cases (e.g., gore areas), and transitions.

A particularity is that the Annex containing a catalog of products which fulfill the indications, where the designer can find all technical information, including drawings and test results.

Additional official documents to be considered are

- Orden Circular 18/2004 and 33/2008 for motorcyclist protection;
- Orden Circular 23/2008 for parapets; and
- Orden Circular 321/95 for other systems.

**TABLE 5 Performance Levels for Crash Cushions**

v (km/h)	50 R	80 R	100 R	110 R
50	X			
60/70/80		X		
90/100			X	
>100				X

TIPO DE CARRETERA	TIPO DE ALINEACIÓN	INCLINACIÓN <sup>(1)</sup> TRANSVERSAL DEL MARGEN <sup>(1)</sup> HORIZONTAL:VERTICAL	RIESGO DE ACCIDENTE	
			GRAVE O MUY GRAVE	NORMAL
CARRETERAS DE CALZADA ÚNICA	Recta, lados interiores de curvas, lado exterior de una curva de radio > 1 500 m	> 8:1	7,5	4,5
		8:1 a 5:1	9	6
		< 5:1	12	8
	Lado exterior de una curva de radio < 1 500 m	> 8:1	12	10
		8:1 a 5:1	14	12
		< 5:1	16	14

**FIGURE 6 Obstacle distance and associated risk (translated in Table 6).**

**TABLE 6 Obstacle Distance and Associated Risk (Translation of Figure 6)**

Type of Road	Type of Alignment	Transverse Side Slopes Horizontal: Vertical	Risk of an Accident	
			Serious or Very Serious	Not Serious
Single carriageway	Straight, inside of curves, and outside of curves with a radius > 1,500 m	>8:1	7.5	4.5
		8:1 to 5:1	9	6
		< 5:1	12	8
	Outside of curves with a radius > 1,500 m	>8:1	12	10
		8:1 to 5:1	13	12
		< 5:1	16	14

RIESGO DE ACCIDENTE <sup>(1)</sup>	CLASE DE CONTENCIÓN	INTENSIDAD MEDIA DE PESADOS POR SENTIDO	NIVEL DE CONTENCIÓN
MUY GRAVE	Muy alta		H3 - H2 - H1
		IMD <sub>p</sub> ≥ 5000	H2 - H1
GRAVE	Alta	400 ≤ IMD <sub>p</sub> < 5000	H1
		IMD <sub>p</sub> < 400	H1 - N2
NORMAL	Normal		H1 - N2

**FIGURE 7 Selection of the containment level according to risk (translated in Table 7).****TABLE 7 Obstacle Distance and Associated Risk (Translation of Figure 7)**

Accident Risk	Containment Class	Average Intensity of Heavy Vehicles in Each Direction	Containment Level
Very serious	Very high		H3-H3-H1
Serious	High	IMD <sub>d</sub> ≥ 5,000	H2-H1
		400 ≤ IMD <sub>p</sub> < 5,000	H1
		IMD <sub>p</sub> < 400	H1-N2
Not serious	Average		H1-N2

## Poland

To complete the review, Poland should also be considered. Although the language is not easily understandable, we can appreciate this regulation existing since 2010. The Generalna Dyrekcja Drog Krajowych i Autostrad (General Directorate for National Roads and Motorways) documented the Wwytyczne Stosowania Drogowych Barrier Ochronnych na Drogach Krajowych (Guidelines for the Use of Road Safety Barriers on Roads) in a report dated April 23, 2010. It describes a classification from EN 1317 and is associated with the speed of the road (70, 100, >100 km/h). Diagrams similar to German ones are available,.

## SITUATION ON EUROPEAN ROADS

As it was seen, more or less all European countries have issued rules for the application of the RRS, which are classified in terms of performances in the EN 1317 and they follow generally similar evaluation criteria.

This however does not lead to the same results, since accepted performances are quite different. Table 8 shows protection levels on the TEN network in Europe, which is indicative of the differences.

**TABLE 8 European Motorways**

Situation in the EU countries :  
Overview on motorways

		Side Barrier	Central Barrier	Bridge Barrier
	Austria	H2 	H2 	H3 
	Belgium	H2 	H2 	H4b 
	Denmark	H1 	H2 	H3 
	Finland	N2 	N2 	H2 
	France	N2 	H1 	N2 
	Germany	H2 	H2 	H3 
	Ireland	N2 	H2 	H2 
	Italy	H2 	H3 	H4b 
	Holland	H2 	H2 	H2 
	Norway	N2 	N2 	H2 
	Spain	H1 	H2 	H3 

It can be imagined that on other roads the situation could be even more widespread.

This is an important point to be considered by the European Commission, in order to start working for a directive for uniformization of safety systems, providing CEN with a mandate in this sense, because experts in this area are already members of its Technical Committees.

The mandate could be for the preparation of the installation standards or, at least, of Installation Guidelines to become the reference for all Europe with the target of reaching consistent level of safety on all European roads.



## SESSION 1: ASSESSMENT PRACTICES

**Latest Update to the British Vehicle Restraint Assessment Process****MARTIN HEATH***MHA Planning and Transport, United Kingdom*

The United Kingdom's roads are among the safest in Europe and worldwide, yet the number of collisions involving vehicles leaving the carriageway remains high when considered as a proportion of all collisions.

Following a major railway crash at Selby in Yorkshire in 2001, the British Deputy Prime Minister set up the Highways Agency Working Group to Review the Standards for the Provision of Nearside Safety Fences on Major Roads. That group concluded that there were no major shortcomings in the safety barrier standard (TD 19/85) and its application to the nearside of major roads. However, a number of concerns were noted, in particular that it was not clear:

- Which risk management principles lay behind the standards;
- What specific risks the procedures or standards were trying to control;
- How risks were assessed when granting formal departures from standard during design; and
- How consistency in the highway authority's advice on safety risks could be pursued.

The review also concluded that the TD 19 Standard was written primarily for new road schemes and that there was a need to manage risks for other types of work, e.g., improvement schemes and upgrades that affect the alignment and speed of traffic.

As an interim measure, until a risk-based standard could be produced, the Interim Requirement for Road Restraint Systems (RRS) document was published in July 2002 which brought together and revised the requirements in all vehicle restraint systems (VRS) and related standards into one document.

Following 4 years of development, a new risk theory-based Road Restraint Standard, TD 19/06, was published, addressing earlier concerns to

- Introduce risk analysis into the design and assessment process;
- Make the risk assessments that are implicit within standards more transparent;
- Provide computer software to enable a risk assessment process to be carried out following recommended design practices to ensure consistency in design appraisal;
- Enable designers to carry out site-specific risk assessments within the design process in order to select appropriate design parameters for all types of works; and
- Provide a framework to support designers in making optimal design choices at specific sites.

## **TD 19 AND THE ROAD RESTRAINTS RISK ASSESSMENT PROCESS**

After a further year of evaluation and consultation, the current national U.K. Standard TD 19 was published as a risk-based RRS Standard, prepared for use by appropriately qualified and experienced professional staff, holding levels of competence as defined within another U.K. DMRB Standard GD02/08: Quality Management Systems for Designers.

TD 19 is not a statutory or regulatory document, nor a training manual; neither does it cover every point in exhaustive detail. Many matters are left to the professional expertise and judgment of designers, emphasizing the need for professional competence amongst designers, while others are covered in British (BS), European (EN), or international standards (ISO) or in Codes of Practice and in Specifications which are cross-referenced in TD 19.

Also, the current TD 19 does not follow the traditional U.K. design standard format and comprises two parts that must be used together,

- The written Standard TD 19 Requirement for Road Restraint Systems, which contains some mandatory requirements but gives mainly advice and guidance; and the
- Road Restraint Risk Assessment Process (RRRAP), an MS Excel spreadsheet that enables a designer to establish the need for a vehicle restraint and its basic performance requirements for each site or scheme.

## **ROAD RESTRAINT SYSTEMS**

RRSs are subdivided into VRS and pedestrian restraint systems (PRS). RRSs are intended to reduce the number and severity of injuries in the event that a vehicle leaves the road and would otherwise encounter a hazardous feature. In protecting vehicle occupants, a RRS also protects against damage to any highway asset located behind the restraint system.

A temporary RRS can also provide the indirect benefit of protection for road workers at places of frequent maintenance intervention where temporary working methods would otherwise require installation of physical barriers.

However, the introduction of a RRS does not always make a hazardous location or situation totally safe and the installation of a fully compliant system may incur significant expense. Every year, many road traffic injuries are sustained from collisions with RRSs and in some circumstances it may be more beneficial to remove or relocate a hazard or decide not to protect it at all.

The British RRS standard and assessment process now recognizes that any RRS carries an inherent element of road user injury risk and that this risk has to be balanced against the benefits of mitigating the severity of any collision at an affordable cost.

## **RELEVANT COLLISIONS**

National collision statistics are reported annually by the U.K. government's Department for Transport. These indicate the extent of the problem and are relevant in defining the types and levels of risk present on the road network.



Clearly this data is based on a very broad range of routes with differing traffic flows and characteristics and this illustrates that the case for the provision of a RRS will vary across different route types. Further detailed analysis of traffic and casualty data is then used to determine the typical frequency with which these types of single-vehicle killed or seriously injured (KSI) collisions occur on different road categories.

Although the risk per mile on an average route is low, the number of run-off KSI collisions represents a high proportion of all road casualties. For example, in 2009 there were a total of 2,057 fatal collisions on all British roads, meaning that the proportion of single vehicles leaving the carriageway is almost half of the Great Britain total of all fatal collisions. This proportion has also increased over the last decade, although the number of single-vehicle collisions has also fallen over the same period.

### RARE, RANDOM EVENTS

Despite the large numbers of collisions nationally, the number of incidents of a vehicle leaving the carriageway at any one particular site is likely to be low. A 2005 research project focused on the factors that influence the travel of the errant vehicles, the relative significance of these factors and potential ways to address them.

Data on errant vehicle travel is vital, both in the context of ensuring a rail tragedy like Selby does not occur again and particularly to inform the risk assessment process developed for an updated design standard for vehicle restraint systems.

Analysis of traffic flow data it is known that the average traffic flow on a major road is around 60,000 vehicles per day [annual average daily traffic (AADT)]. This is the daily two-way flow and equates to approximately 22 million vehicles per year on the English major road network. Of these, adjusted collision data has shown that an average of 3,364 vehicles left the carriageway on the nearside each year (between 1990 and 1998), giving a probability of  $3,364/22,000,000$  or 0.00015 (Figure 1).

Adjusted STATS 19 information has shown that of 3,364 vehicles leaving the carriageway between 1990 and 1998, an average of 674 vehicles per year left the carriageway but did not strike either a nearside barrier or any other item of roadside furniture. This amounts to a probability of  $674/3,364$  or 0.2004.

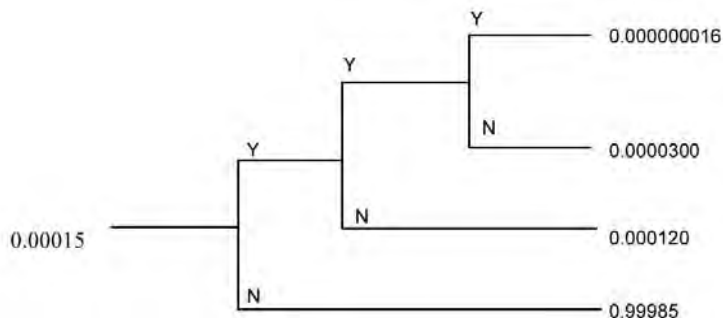

**FIGURE 1** Analysis of traffic flow data.

The potential for vehicles to leave the carriageway, miss an existing RRS, and collide with a major feature such as a railway can therefore be calculated using an event tree analysis, as shown below:

- Initiating event. A single-vehicle accident where a vehicle leaves the carriageway on the nearside of a major road: 0.00015.
- First phase. Vehicle does not strike a roadside feature: 0.2004.
- Second phase. Vehicle reaches a railway line: 0.000534.
- Outcome. Probability of all three factors occurring results in the overall probability: 0.000000016.

This shows how we can determine that while the potential for this scenario arising is real and the consequences are likely to be catastrophic, the likelihood of it materializing is very low and this is a major decision-making tool for the road designer.

It follows then, that the probability of a vehicle striking any roadside feature, including a RRS in the nearside verge, can be also estimated using available data:

$$0.00015 \times (1,474 + 0.6522) = 0.00012$$

## INJURY SEVERITY

Not all run-off-road collisions will result in a fatal injury and this is an important area for the designer to consider. All designers will have different opinions about the relative safety of different roadside objects and their aggressiveness value may be dependent upon a designer's own experience or some form of data research (Table 1).

The TD 19 Standard and RRRAP aim to harmonize this thinking among designers by establishing standard aggressiveness factors for all types of roadside objects, removing the subjectivity that can sometime surround hazard perception and influence decision making. The RRRAP allocates an aggressiveness value to each hazard within reasonable reach of vehicles leaving the road (up to 100 m) and quantifies risk by estimating the equivalent fatalities per vehicle kilometer.

For very aggressive objects adjacent to high-speed roads, the RRRAP indicates that the provision of a VRS is required to lower the risk to an acceptable level, regardless of the traffic flow and probability of collision. To remove some anomalous and unexpected results various aggressiveness factors for hazards were recently modified, using expert opinion.

It is interesting to observe how different such ratings can be between different countries, some of which can be explained by variations in the relevant injury accident reporting systems.

Of particularly topical interest at the moment is how high the collision potential is with the ramped ends of RRS terminal and what severity of injuries might result from it. In unpublished U.K. research it was concluded that the potential for injury arising from a collisions with ramped terminal on the nearside was equivalent to that shown in U.S. data in Table 1 as guardrail–safety end.

The research suggests the likelihood of injury to be roughly 25% of that associated with an impact with a large diameter signpost. Using encroachment theory with data from U.S. roads, it was estimated that the number of injury accidents per ramped end might be one in every 300 years.

**TABLE 1 Accident Statistics**

<b>Kerb</b>	<b>Guardrail</b>	<b>“Safe” Guardrail End</b>	<b>Small Signpost Parapet Rail?</b>	<b>Lighting Column</b>	<b>Culvert</b>	<b>Utility Pole</b>	<b>Tree Large Signpost</b>	<b>Bridge Pier</b>
Based on injury accidents per collision (U.S. data):								
0.1	0.30	0.40	0.6	1.0	1.3	1.4	1.6	2.0
Based on fatalities per injury accident (U.S. data):								
	1.1		0.8			1.1	2.4	
Based on fatalities per injury (STATS19 U.K. data)								
	0.8		0.85	1.0			1.5	

Table 2 shows the kinds of objects resulting in fatal injury on the British strategic road network over a 4-year period.

## MODELLING RRS REQUIREMENT

In the United Kingdom, a 3.3-m hard shoulder is standard on motorways. A 1-m strip is used on both single and dual-carriageway trunk roads; in the latter case where traffic speeds of 70 mph are allowed. There is no clear zone as such required and most research in the United Kingdom has therefore been aimed at assessing when it is necessary to remove the hazards or to provide additional protection.

This required a model to be developed that allows the costs and benefits to be evaluated more directly for a variety of different roadside conditions. The model subsequently developed by Mouchel and the U.K. Transport Research Laboratory as part of the introduction of risk assessment into road restraint standards provided a basis for this.

Models are needed to show how these factors involved combine to reflect overall risk at particular sites. Data have been collated in this report that will provide the following input to such models:

1. Encroachment angles. No evidence was directly available for United Kingdom, but U.S. studies suggest that the angle varies with type of run-off and a probability distribution is provided with the majority of runoffs being between 5° and 15°.
2. Frictional resistance during run-off. Unbraked run-offs over good ground will produce very little deceleration (perhaps 0.1 g) but this can increase to 0.5 g over loose gravel. Braked runs over loose gravel can produce decelerations of 1 g, but over hard ground probably only about half this value.
3. Effect of slope on likelihood of rollover. Down slopes greater than 1:3 results in a high likelihood of rollover; even on slopes of 1:4 the scope for driver control over short distances will be limited.
4. Severity of injury resulting from hitting different objects. Impacts with trees are 50% more likely to result in severe injury than impacts with signs and lampposts; there remains a significant probability of injury after impact with roadside barriers.
5. Collision data. On the overall outcomes from the combined effect of these factors.

**TABLE 2 Objects Impacted on the Roadside**

<b>Percentage of All Nearside Run-Off Accidents for Each Road Type by Object Hit</b>			
<b>Object Hit</b>	<b>Motorway</b>	<b>Dual Carriageway</b>	<b>Single (60 mph)</b>
None	20	19	19
Central crash barrier	3	3	—
Entered ditch	9	12	14
Lamp post	4	12	6
Nearside–offside crash barrier	31	13	3
Other permanent object	19	16	30
Road sign–traffic signals	4	11	8
Telegraph–electricity pole	0	1	3
Trees	10	14	18

Any models starting with these values need to be calibrated against collision data from British road sites to demonstrate the validity of their forecasts for them sites. Research analysis concluded that

- The basic methodology exists to make risk assessments at these sites; and
- Data exists (mostly from other countries) on the values to be used for the parameters in these models.

There is no reason to believe that overseas values are fundamentally different for British conditions, so there is value to be gained from further research, such as

- Identifying improvements that can be made to the risk estimates for British roads by refining the values used; and
- Demonstrating that the output of the models is consistent with observed collision patterns on British roads.

## **LIMITATIONS OF TD 19 AND RRRAP**

Advice on the provision of RRSs within TD 19 is based on the estimation of risk rather than the consideration of local collision history. This risk estimation tool, the spreadsheet-based RRRAP, has been developed using British collision records for roads with speeds of 50 mph or greater and with traffic flows of more than 5,000 vehicles of any classification (AADT).

The RRRAP is an integral part of the decision whether or not to provide safety barrier in TD 19. The provision of other forms of RRSs as described in TD 19 (e.g., terminals) is dependent upon the decision to provide safety barrier or a vehicle parapet and as such not directly dependant on the RRRAP.

However, there are a number of reasons why use of the RRRAP risk model is not suitable for direct application to low speed or low-flow roads:

- The RRRAP data is from a large number of routes that share a large number of common features;

- Local authority roads are much more diverse and a huge variety of risk-related circumstances exist;
- RRRAP data is from routes that have substantially better road geometry; and
- RRRAP data is from routes that have other safety features that would not typically be present on local highway authority routes, e.g., hard shoulders or strips, motorway incident detection, and automatic signaling.

## LOCAL ROAD APPLICATIONS

Experience of using the TD 19 risk-based approach to low speed and low flow roads found it likely to result in over application of RRS's and may not represent best use of limited resources. TD 19 is therefore not considered suitable for use on the majority of Britain's local road network.

Due to the limitations in research and quality of collision data, it has not been possible to produce a prescriptive set of design standards to inform the application of RRSs on local authority roads. As a result, most local road authority engineers have struggled with the use of TD 19–RRRAP and the interpolation of outputs to fit local road scenarios.

A new guidance document for local roads was published at the end of 2011 and now provides a basis for appraisal to help local roads authorities decide when a RRS is justified. This new appraisal framework takes account of several diverse, influencing factors including risk assessment but also considers alternative solutions, system feasibility, cost–benefit analysis and the availability of funding.

The guidance was developed for the United Kingdom Roads Liaison Group (UKRLG) and can be adapted by local highway authorities to create a pragmatic system for decision making to help them make best use of the finite resources available to them.

## LOCAL ROADS GUIDANCE

Justification for the introduction of expensive RRSs to reduce the risk is a major challenge for local highway authorities, especially at a time when funding for maintenance and improvements scheme is already limited. Roads authorities must be confident that any measures introduced represent good value for money.

The UKRLG guidance describes a process to assist highway authority decision making with regards to investing in a RRS at a particular site and includes the necessary supporting information to assist this process and takes account of risk, risk assessment methods, costs, benefits as well as further advice on performance specification and outline design.

The new guidance is not intended to replace TD19 in a local authority context, but it offers alternatives to the RRRAP system of appraisal upon which TD19 relies. Once a decision to install a RRS has been made, the design advice given in TD19 remains relevant to low-speed and low-flow roads and has applications for

- New roads (and the adoption of privately constructed roads);
- Road improvements, e.g., widening and junction improvements;

- Where a new hazard is introduced or an existing roadside feature is altered, e.g., the addition of roadside features;
- Where the upgrade or replacement of a parapet is being considered;
- Maintenance schemes where a significant length of RRS is being replaced; and
- When the safety performance of a particular site has been questioned and risk reduction options are being assessed.

The large variety of circumstances faced by local roads authorities makes the provision of prescriptive guidance inappropriate and the core intention for this guidance document is to assist with local decision making. Inherent in such decision making is framing such decisions within the context of an overall RRS policy and UKRLG recommends that local roads authorities adopt a robust policy for the provision of RRSs.

The ways in which roads authorities manage the risk of vehicles leaving the carriageway and colliding with a roadside object, depend on the nature of the routes they maintain; the funds available to them at any time; and what level of risk an authority considers tolerable. The guidance provides a list of potentially hazardous roadside features, similar to TD 19 and the introduction of any of feature alongside a road is sufficient to justify application of the appraisal process.

Where a RRS already exists and is life-expired, a local authority may wish to undertake a review before automatically replacing the system. In such cases the initial justification for the barrier should be understood and a determination made as to whether this justification is still valid. Maintenance records and an inspection of any damage to the system may indicate that the barrier has served its purpose.

## **DEVELOPING A RISK MANAGEMENT APPROACH**

The TD 19 Standard advocates the use of locally derived risk management processes to ensure that decision making is as robust as possible. For many, this results in the development of some form of risk scoring methodology although is not recommended in situations where collision data can be used to estimate the risk or if there is a road rail interface.

As with any risk-based assessment, robust hazard identification is needed, carried out by competent professionals and supported by secure data recording and documentation systems. The scoring methodology used should assume a primary roadside hazard(s) has been identified. Where a number of hazards are identified present within a relatively contained section of roadside, up to say, 50 m the UKRLG suggests that the one considered to have the highest severity outcome should be assessed. This decision will be most likely based upon collision data research for the local authority as a whole.

### **Collision Risk**

Scoring of the risk of collision is beneficial where the decision to provide a RRS is not simple and risks to errant vehicles are difficult to determine. At some locations, however, risk of injury can be assumed to be sufficiently high to justify automatic progression to the next stage of the assessment, for example, the likelihood of collision with any of the following:

- Public building,
- Place of regular congregation (e.g., outside a school),
- Office block or workplace,
- Large block of flats, and
- Playground or open sports area.

### Route Type

Levels of risk vary according to regional influences and route characteristics, including the prevailing speed limit and volume/composition of motor traffic. The route type assessment collectively considers all of these elements and results in a risk score that represents the overall nature of the road, adjacent to the hazards in question (Table 3).

### Layout Factor

Assessment of the influence of road layout on the propensity for vehicles to leave the road and collide with roadside hazards is a two part analysis in the UKRLG guidance (Table 4).

Road geometry is acknowledged to play a key role in the likelihood of vehicles leaving the road, with a variety of features known to potentially increase the risk. The most obvious of these is horizontal alignment or curve radius, although data suggests that fewer vehicles leave the road on curves. Geometric assessment includes traffic speed, curvature radius, presence or otherwise of super elevation, the influence of transition curves, and road surface performance.

U.K. design standards provide strong guidance on horizontal curves. More recent research by Herrstedt and Greibe (2001) recognized that the risk increases as the curve design speed drops below the approach speed. TD 19–RRRAP asks the designer to record whether the alignment meets current standards for the design speed of the road. The UKRLG suggests taking each step below the desirable minimum standard, as a 1 point increase in risk.

The second layout factor is the complexity of the carriageway layout at the location of the

**TABLE 3 Route Factor**

Priority Rank	Risk Factor Score
0 – All other roads	0
1 – Rural U and B roads and urban C roads	1
2 – Rural A roads and urban B roads	3
3 – Urban A roads	6

**TABLE 4 First Layout Factor**

Priority Rank	Risk Factor Score
0 – Straight alignment or complies with TD 9	0
1 – One step below desirable minimum R with superelevation of 5%	1
2 – Two steps below desirable minimum R with superelevation of 5%	2
3 – Three steps below desirable minimum R with superelevation of 5%	3
4 – Four steps below desirable minimum R with superelevation of 5%	4
5 – Five steps below desirable minimum R with superelevation of 5%	5

hazard, where there may be an increased risk of a vehicle leaving the carriageway (Table 5):

- Where vehicles merge or diverge;
- Where overtaking sections exist on rural roads;
- At intersections where visibility is poor or the vehicle is concealed by the carriageway alignment;
- Where road space is constrained and reversing or positioning maneuvers take place;
- At traffic signals where drivers may need to avoid traffic queues; and
- Near roundabout exits and at central islands or refuges.

Scoring the extent of these factors in so far as they affect risk requires competent judgment, since it is not always the case that layouts that fail to meet standards are of a higher risk. The degree of compliance with standards may be a mitigating factor.

The higher of the two values from this assessment is used in the UKRLG guidance.

### Collision Factors

A two-part assessment is advocated for the evaluation of collision factors on local roads. In the first, a spot hazard such as a traffic signpost or lighting column provides less of an obstruction than a longitudinal hazard such as a retaining wall or parallel canal (Table 6). Where there are a number of hazards grouped together, such as a copse of trees or a number of signs in a diverge nosing, a judgment is required to decide whether this should be treated as a group of spot hazards or one continuous hazard.

This factor also takes into account the increased risk posed by a hazard that is located such that a longitudinal feature (such as a wall) could divert vehicles leaving the carriageway towards the hazard.

The second part of this assessment is the severity of outcome (Table 7). Any vehicle impact with a roadside hazard is likely to result in some form of physical injury, although a variety of other

**TABLE 5 Second Layout Factor**

Priority Rank	Risk Factor Score
0 – No reason for lane changing or maneuvers	0
1 – Some potential for lane changing, overtaking, positioning maneuvers, or avoiding action	2
2 – High likelihood of lane changing, overtaking, positioning maneuvers, or avoiding action	3

**TABLE 6 Collision Factor**

Priority Rank	Risk Factor Score
0 – Individual spot hazard	0
1 – Series of individual hazards less than 50 m apart or a longitudinal hazard that might be reached	1
2 – Longitudinal hazard that is highly likely to be reached resulting in harm or a spot hazard downstream of a feature that may guide the vehicle towards the hazard	2



**TABLE 7 Severity of Outcome**

Priority Rank	Risk Factor Score
0 – Percentage of KSI for primary hazard < 20%	0
1 – Percentage of KSI for primary hazard 20%–30%	1
2 – Percentage of KSI for primary hazard > 30%	2

circumstances dictate severity of injury. However, the UKRLG guidance suggests that the severity of outcome can be considered and that national KSI data can be used to determine the correct value. Where there are multiple hazards present it is suggested that the severity value associated with the most aggressive hazard is used.

### Secondary Incidents

In some cases, a roadside collision can result in a secondary event that creates a hazard for other road users and increases the risk of a secondary incident. This is often cited as a feature of collisions with frangible or passive roadside objects, such as the collapse of the primary hazard. The consequences of an object collapsing onto a footway are ignored in the UKRLG guidance unless it is likely that a pedestrian would be present for the majority of the time. However, when it might result in a major secondary incident off carriageway, this is considered to constitute a higher priority site automatically.

A consequential secondary incident is that of network disruption (congestion and delay) arising from the event, usually due to carriageway obstruction by the collapsed object or damaged vehicles. Scoring of this factor would normally consider the possible disruption that may be caused by the duration of the obstruction and any repair required to the highway or object in order to make the road safe.

These consequential factors are scored based upon whether they are judged to be able to occur or not. Zero points are scored if no occurrence is considered likely and one point is scored if an occurrence is likely.

### Total Risk Value

These four assessment factors (F) result in a combined score, which can be used to assign a priority level (high, medium, or low) to the site under investigation. Each level has a band width for guidance which local authorities can adjust to suit their own policy.

$$\begin{aligned}
 &F_{\text{LOCATION}} \text{ (range 0 to 6) +} \\
 &F_{\text{LAYOUT}} \text{ (largest of two scores, range 0 to 5 or 0 to 3) +} \\
 &F_{\text{COLLISION}} \text{ (sum of two separate scores, range 0 to 4) +} \\
 &F_{\text{CONSEQUENTIAL}} \text{ (sum of three separate scores, range 0 to 3)}
 \end{aligned}$$

Recommended upper and lower bounds for the three risk classifications are

Total Risk Ranking Score	Category
14 or more	Higher priority
9 to 13	Medium priority
0 to 8	Lower priority

SESSION 2  
**Safe Systems**



## SESSION 2: SAFE SYSTEMS

**Introduction (or Reintroduction) to the Safe System Approach****RAPHAEL H. GRZEBIETA****LORI MOOREN****SOAMES JOB***Transport and Road Safety Research, University of New South Wales, Sydney, Australia  
International Safe Systems Institute for Road Safety*

**S**afe System thinking evolved from the visions that emerged in Sweden and the Netherlands in the mid-1990s and then later from Australia at the turn of the century in 1999 to 2002 (1, 2). However, the application of this thinking relies on road authorities and others interpreting the principles and planning actions that are consistent with this thinking.

The Safe System approach to road safety was adopted in principle by Australian Road and Transport Ministers through the Australian Transport Council in 2004 (3). This policy principle now underpins Australian road safety strategies in all jurisdictions in the country (4). It also underpins the Global Decade of Action for Road Safety 2011–2020 Plan (5, 6).

It is said that this approach represents a paradigm shift (1, 2, 7, 8) in road safety approaches. The shift is from treating road injury factors as notionally equal with the underlying assumption that there will always be injury risks inherent in road travel, to conceptualizing and pursuing the development and management of a road traffic transport system that is inherently safe for human users. The Safe System approach calls for road, vehicle, cyclist, pedestrian, and management design parameters that acknowledge human fallibility and vulnerability and places a biomechanical injury tolerance criterion and consideration of human fallibility as the central governing principle underpinning any road safety policy decisions.

Under the former epidemiological (Haddon) approach (9) to road safety, discrete injury factors were systematically identified and countermeasures to these factors were implemented, often guided by benefit–cost analysis. For example, in the case of roads and single-vehicle crashes through and beyond clear zones, it is still accepted by Australian road design engineers that around 15% to 20% of people will not recover from an incident or crash with ensuing associated fatalities and injuries (10, 11). This is based on U.S. AASHTO 2006 Road Design Guidelines (12) where the United States is one of the poorer-performing developed countries in terms of road safety outcomes (13). Moreover, this approach masked or smeared over detailed in-depth analysis that highlighted design flaws, biomechanical human injury hazards, and behavioral errors that were interrelated in a systems context. While this epidemiological approach significantly helped mitigate fatalities and injuries in a broader road safety context, reducing fatality and injury numbers had become more difficult in recent years and thus required this paradigm shift. It was important to recognize that humans do make errors and to assess the consequences of those errors and proposed countermeasures that reduced crash severity to survivable limits or eliminated or compensated for the human error (1, 7, 8, 14–16).

A key principle of the Safe System approach is a shift of responsibility from an emphasis on road users being responsible for their behavior on the road to a greater responsibility for road system designers and managers to build safe guards into the system to prevent injury-causing crashes. The bottom line in this new paradigm for road safety is the extent to which road injury

and fatalities are reduced or eliminated rather than trading off lives and injuries for the benefit of mobility and cost efficiency. Nevertheless, individual road users have the responsibility to abide by laws and regulations, i.e., travel within the speed limit, wear seatbelts and helmets, don't drink and drive, don't text and drive, and be alert and not sleep deprived, etc.

## INTRODUCTION OF VISION ZERO CONCEPTS IN AUSTRALIA

In November 1998, Tingvall, then working with the Monash University Accident Research Centre, introduced his new paradigm for injury prevention, namely Vision Zero, at the Road Safety Research, Policing and Education Conference in Wellington, New Zealand (1).

However prior to Tingvall's arrival researchers were already highlighting flaws and questioning the moral ethics of the road transport system. Job et al. in 1989 noted that

many fatalities occur not because of driver error but because of driver error combined with a negligent designed road system and a politically acceptable but technically substandard vehicle. Most of us would not condone a legal system which handed out the death penalty (or permanent disability) for "crimes" such as the misjudging of the camber of the road or driving when slightly drowsy, so we should not accept a politically determined traffic system which metes out such penalties. (14)

Murray, Grzebieta, and Rechnitzer, along with Job et al. and others in Australia, had also been researching and highlighting various flaws in vehicles and the road system (7, 8, 15) such as poor roof strength for rollover crashworthiness; inadequate near- and far-side impact occupant protection; geometric T-bone crash compatibility between heavy vehicles and cars; lack of adequate truck under-run barriers decapitating car occupants; poor frontal impact compatibility between trams, buses, and pedestrians; spearing w-beam roadside barriers and roadside poles; and tree impacts. These researchers had also highlighted on a number of occasions the inadequacy of the Australian Design Rules in regards to vehicle crashworthiness. This helped precipitate the formation in 1993 of the Australian New Car Assessment (NCAP) program, which, in turn, inspired EuroNCAP and further expansion of consumer testing in the United States through the Insurance Institute of Highway Safety and U.S. NHTSA.

Rechnitzer and Grzebieta then took up Tingvall's lead by presenting these various flaws in the road transport system at an "Aus Top Tec" Topical Technical Symposia run by the Society of Automotive Engineers Australia, in Melbourne, in 1999 (8). They supported a paradigm shift away from the economic cost-benefit model, widely used throughout the western world where deaths and injuries are an acceptable cost of mobility that commonly resulted in the flaws outlined in their paper, to a crashworthy system underpinned by Tingvall's more humanistic biomechanical model where "any foreseeable accident should not be more severe than the tolerance of the human body in order not to receive an injury that causes long term health loss".

Grzebieta and Rechnitzer then highlighted in their part 2 sequel paper, *Crashworthy Systems: A Paradigm Shift in Road Safety Design* in 2001 (7), and how the national road toll had stagnated over the past 5 years, as shown in [Figure 1](#), and indeed was rising back up again to levels 8 years prior and a paradigm shift in thinking was essential to reach any further gains.

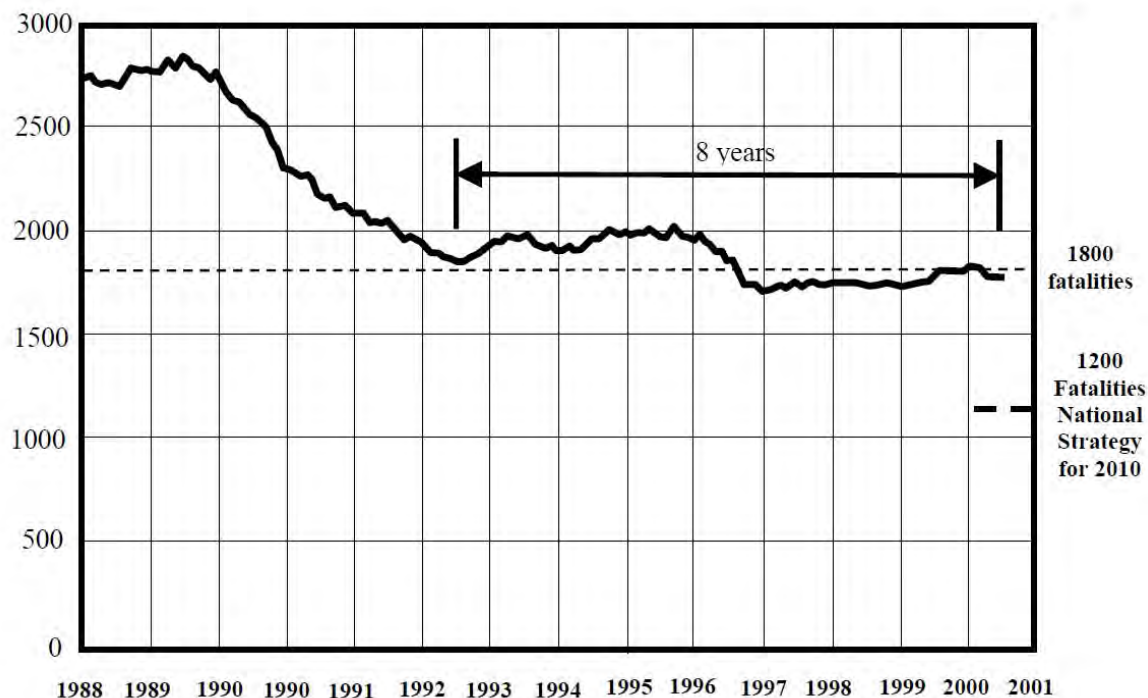

**FIGURE 1 Australian road deaths after Grzebieta and Rechnitzer (7).**

They further highlighted in another paper (17) the crash energy management and system compatibility with other road users: reduce the exchange of energy between impacting vehicles; manage the exchange of energy rather than attempt to dissipate the full kinetic energy of the vehicle–road users involved; make interfaces compatible (stiffness and geometric) between interacting systems, be they structures, roadside objects, vehicles, or humans; and provide energy absorption to reduce forces and accelerations on vehicles, vehicle occupants, and unprotected road users. They further stated that “road and vehicle systems must now be designed to tolerate human error. The systems must negate high-risk behaviour if we are to advance towards a zero road toll. Any uncontrollable errors that do occur must be benign in terms of injury and fatalities.”

Fildes also highlighted the stall in terms of fatality reductions and also advocated for a Vision Zero and systems approach to road safety in November 2001 (18). Significant controversy between policy makers and engineers via a number of newspaper opinion articles by Grzebieta and Rechnitzer ensued at the time in early 2002 (19, 20) as a consequence of a call for redesign of a safer road system and a Vision Zero approach.

Design engineers were concerned about the cost and how realistic was achieving zero deaths on the roads. Australian road designers were underpinned by design guidelines that effectively permitted in the case of clear zones that around 15% to 20% of people who run off the road will not recover from the incident and possibly crash and die or be seriously injured (10, 11). This was a trade-off for reducing costs of road construction while maintaining mobility. In effect, this meant that the public policy position was more like Vision 85%. That is, the road design principles accepted that some people would necessarily die in road crashes.

Road safety debate on these principles continued, but in 2004 the Australian Transport Council adopted the principles of a Safe System to underpin Australian road safety. Put

simply, this is a policy that does not accept that human road users will die or be seriously injured and that the design parameter of road systems would be human tolerance to crash forces resulting from dissipation of kinetic energy.

### SAFE SYSTEM: VICTORIA'S STARTING POINT

In September 1999, Tingvall, together with Haworth published a paper where they recommended that the State of Victoria adopt a Vision Zero approach to road safety (2), advised that the only way to radically reduce the road toll in the state of Victoria was to drop the road travel speeds and gradually align speeds to the inherent safety of the system as a practical start. Long-term maximum speed limits for differing types of road infrastructure were recommended, assuming best-practice vehicle safety design and 100% restraint use as depicted in [Table 1](#). The Vision Zero philosophy demands that road conflicts do not result in serious harm to the health of any road user. Reducing speed limits is one means of achieving reductions in serious harm if money is not available to engineer safety in the system. But given that reducing speed limits is a most contestable road safety issue for the Australian community, the full adoption of the Vision Zero approach was initially rejected by policy makers.

Instead, a slightly less radical concept, the Safe System approach, emerged in the State of Victoria in 2004 and similar developments occurred in New South Wales (NSW) with the third author Job heading road safety in that state at that time. In NSW these developments led to the more cautious name: the Safe Systems Partnership approach emphasizing the partnership with road users. The Safe Systems principles were later endorsed by the Australian Transport Council in their 2004–2005 Road Safety Strategy. This signaled an acceptance of the paradigm shift in road safety thinking, research, and strategy. Thus the Safe System approach was founded on Vision Zero principles, but requires that road users remain alert and compliant in order to ensure harm avoidance (21). The Safe System model is provided in [Figure 2](#). At the same time as this was occurring, a concerted effort was underway by other Monash University researchers (Ogden and Daly) who had moved to industry positions and were advocating star rating road systems after a return visit to Australia by Tingvall. This spawned the birth of AusRAP as the sister program of EuroRAP, which safety rates road infrastructure.

**TABLE 1 Possible Long-Term Maximum Travel Speeds Under Vision Zero  
[Reproduced from Tingvall and Haworth (2)]**

Type of Infrastructure and Traffic	Possible Travel Speed
Locations with possible conflicts between pedestrians and cars	30
Intersections with possible side impacts between cars	50
Roads with possible frontal impacts between cars	70
Roads with no possibility of side impact or frontal impact (only impact with infrastructure)	100+



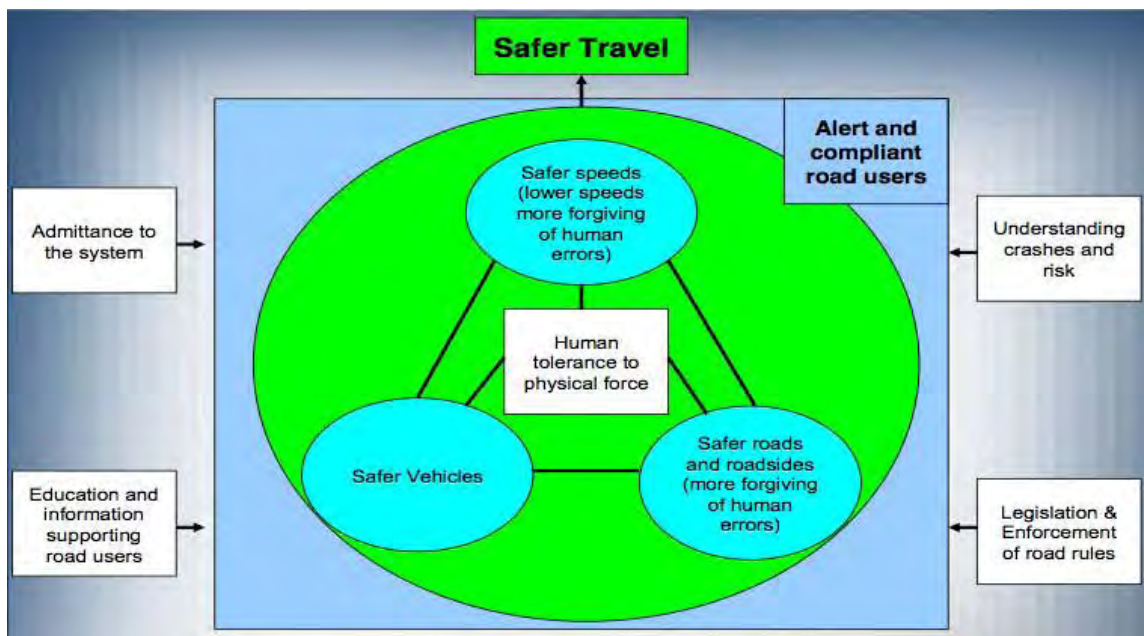

**FIGURE 2** The Safe System model reproduced from Howard (21).

Under the Safe System approach, road and vehicle designers and managers are responsible for designing, producing and managing road travel infrastructure and equipment. Beyond this, road and transport authorities are responsible for putting in place rules and guidance to Safe System use and road users themselves are responsible for abiding by the rules and being alert to injury risks.

The Safe System philosophy recognizes that people make mistakes, but it requires a proactive approach to reduce injury risks through road, vehicle, speed, and behavior management. Thus, collisions in the road environment due to human error should not exceed the human body tolerance to physical force. This new paradigm also accepted that humans make errors and that corrections need to be made to the system to reduce harm consequences of errors if the error could not be mitigated through corrective design or active or passive intervention. Between the years 2001 and 2004, the Victorian Government introduced a number of strong measures to reduce the risks of unsafe travel speeds. Other efforts at achieving road user compliance focused on initiatives to reduce alcohol and drug impaired driving.

Following the adoption of the Safe System principle a number of programs to enhance the safety of roads, roadsides and vehicles were also introduced with a boost in funding to address the biggest infrastructure contributions to road injury. In 2004, Victoria commenced a Safer Road Infrastructure Program, initially injecting \$130 million for 113 projects designed to address the major crash type risks in the network. Another injection of \$110 million for 252 projects was allocated in 2006, followed by a commitment of \$650 million in 2007 for projects to be carried out over the next 10 years. Victoria continued to reduce its fatalities and fatality rates until 2007 (Figure 3) and by the end of calendar year 2010 the fatality rate per 100,000 population was 5.2.



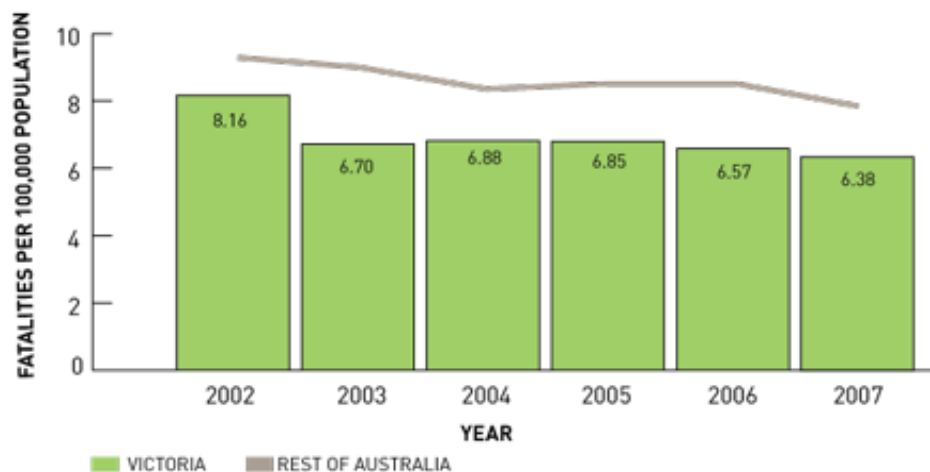

**FIGURE 3** Victoria's fatality rate trend compared with the Australian average.

Victoria has made good strides in road safety, but the challenges continue. The challenges are largely not technical or scientific challenges. They are mainly political and social challenges. The biggest challenge is to win public support for lower road travel speeds. However, the challenges include addressing a Safe System for motorcyclists, aligning engineering guidelines with Safe System principles, raising awareness of the Safe System approach by key stakeholders, and considering the role of intelligent transportation systems, performance indicators, and the use of route-based strategies.

The starting points and characteristics for the two other Australian states, namely NSW and Western Australia, were different because of their governance and political environments. A comparison of these characteristics and performance are provided in the Mooren et al. paper referenced in the footnote on first page of this paper.

## SUMMARY AND CONCLUSIONS

The Safe System approach and its predecessors, Vision Zero and Sustainable Safety, represent a substantial shift in how road safety problems and solutions are conceived. It requires researchers and practitioners to embrace the new scientific basis for analysis and actions. And in order to achieve safety results whilst maintaining a good level of community support, an injection of funding for refitting the road infrastructure is needed. Moreover, two of the primary levers of the Safe System are forgiving roads and roadsides and speed management set to levels needed for sustaining human health. These two aspects bring significant engineering and political challenges.

The Safe System approach recognizes the inherent vulnerability and fallibility of human road users and invokes active and passive mitigation strategies that encourage system self-correction on a number of fronts. It requires that these characteristics be taken into account in the design and management of the road traffic system. A Safe System approach is the only way to achieve the vision of zero road fatalities and serious injuries, as this approach means that the road system is designed to expect and accommodate human error and correct for it (13). It does not just build infrastructure and put in place road rules with the assumption that road users will

use the road in the way that the designers intended. The challenges of the Safe System include the following:

- The infrastructure engineering fraternity will be required to fundamentally change the focus of their work from building roads which accept that a certain level of death and injury will always occur, to building roads which recognize human error, encourages self-correction, and if human error does occur, reduces the crash forces to not only survivable levels but also to levels where a road user can fully recover from the event.
- Motor vehicle manufacturers will need to design cars with both active and passive safety. The vehicles must perceive when the driver is about to lose control of the vehicle and actively correct the vehicle either back on track or away from the crash trajectory or, if a crash is imminent, slow the vehicle down faster than the driver can while activating all restraint systems into crash mode. The passive crashworthy systems must then activate during the crash event.
- Motor vehicle drivers will be, in many instances, required to drive more slowly than they might like until inherent safety of the road traffic system can be assured.
- The aims of no harm to humans may seem unrealistic to the community and many of its leaders.
- Additional resourcing may be required to meet the needs of infrastructure re-engineering, especially in countries with vast road networks and small populations.
- Technological developments to vehicles and equipment need to be better informed by research into human behavioral capabilities, choices, susceptibility to errors, and capacity to withstand physical force.

The ability to meet these challenges will be in part determined by the level of political and managerial commitment and leadership (22) that will be required of governments to pursue ambitious road safety objectives.

## ACKNOWLEDGMENT

This short paper is a compiled extract of a longer paper by L. Mooren, R. Grzebieta, and S. Job, *Safe System—Comparisons of This Approach in Australia*, presented at Australasian College of Road Safety National Conference, *A Safe System—Making It Happen!* Melbourne, September 2011. The paper can be accessed at <http://acrs.org.au/wp-content/uploads/Mooren-et-al-Safe-System-%E2%80%93-Comparisons-of-this-Approach-in-Australia.pdf>.

## REFERENCES

1. Tingvall, C. *The Swedish Vision Zero and How Parliamentary Approval Was Obtained*. Presented at Australasian Road Safety Research, Policing and Education Conference, Wellington, New Zealand, 1998.
2. Tingvall, C., and N. Haworth. *Vision Zero—An Ethical Approach to Safety and Mobility*. Presented at 6th ITE International Conference: Road Safety and Traffic Enforcement: Beyond 2000, Melbourne, 1999.
3. National Road Safety Initiatives, Australian Transport Council, 2004. Available at [http://www.atcouncil.gov.au/communique/atc20.aspx - NRS\\_initiatives](http://www.atcouncil.gov.au/communique/atc20.aspx - NRS_initiatives). Accessed March 4, 2011.

4. Australian Transport Council. National Road Safety Strategy 2011–2020. 2011. Available at <http://www.atcouncil.gov.au/documents/atcnrss.aspx>. Accessed July 8, 2011.
5. World Health Organisation. First Global Ministerial Conference on Road Safety: Time for Action, Moscow Declaration, Moscow, November 2009, Available at [http://www.who.int/roadsafety/decade\\_of\\_action/en/](http://www.who.int/roadsafety/decade_of_action/en/). Accessed July 8, 2011.
6. World Health Organisation. Global Plan for the Decade of Action for Road Safety 2011–2020. 2011. Available at [http://www.who.int/roadsafety/decade\\_of\\_action/plan/plan\\_english.pdf](http://www.who.int/roadsafety/decade_of_action/plan/plan_english.pdf). Accessed July 8, 2011.
7. Grzebieta, R. H., and G. Rechnitzer. Crashworthy Systems—A Paradigm Shift in Road Safety Design (Part II). *Transport Engineering in Australia*, Vol. 7, No. 1–2, 2001.
8. Rechnitzer, G., and R. H. Grzebieta. Crashworthy Systems—A Paradigm Shift in Road Safety Design. *Transport Engineering in Australia*, Vol. 5, No. 2, 1999. (Also in *Proc., Aus Top Tec Topical Technical Symposia*, Society of Automotive Engineers Australia, Melbourne, 1999).
9. Haddon, W., Jr. The Changing Approach to the Epidemiology, Prevention, and Amelioration of Trauma: The Transition to Approaches Etiologically Rather Than Descriptively Based. *American Journal of Public Health*, Vol. 58, 1968, pp. 1431–1438.
10. Austroads. *Guide to Road Safety Part 6: Road Safety Audit*. Austroads Publication No. AGRS06/09.
11. Austroads. *Guide to Road Design Part 6: Roadside Design, Safety and Barriers*, Austroads Publication No. AGRS06/10.
12. *Roadside Design Guide* (3rd ed.), American Association of State Highway and Transportation Officials, Washington, D.C., 2006.
13. *Towards Zero: Ambitious Road Safety Targets and the Safe System Approach*, Organisation for Economic Co-operation and Development, Paris, 2008. Available at <http://www.internationaltransportforum.org/jtrc/safety/targets/08TargetsSummary.pdf>; <http://www.internationaltransportforum.org/Pub/pdf/08TowardsZeroE.pdf>.
14. Job, R. F. S., E. J. Fleming, and G. P. Brecht. Traffic Accidents Are a Political Issue. *Medical Journal of Australia*, Vol. 151, 1989, p. 356.
15. Murray N. *When It Comes to the Crunch: The Mechanics of Car Collisions*, World Scientific Publishing, 1994.
16. Sabey, B., and H. Taylor. *The Known Risks We Run: The Highway*. Transport and Road Safety Research Laboratory, Crowthorne, United Kingdom, 1980.
17. Grzebieta, R. H., and G. Rechnitzer. Vision Zero—The Need for Crashworthy Systems. *Proc., 24th Australasian Transport Research Forum, Zero Road Toll—A Dream or a Realistic Vision?*, 2001. Available at [http://www.patrec.org/web\\_docs/atrf/papers/2001/1419\\_Grzebieta%20&%20Rechnitzer%20\(2001\).pdf](http://www.patrec.org/web_docs/atrf/papers/2001/1419_Grzebieta%20&%20Rechnitzer%20(2001).pdf).
18. Fildes, B. Achieving the National Strategy Target: A Role for Vision Zero? *Australasian Road Safety Research, Policing and Education*, 2001, Melbourne.
19. Grzebieta, R., and G. Rechnitzer. Designs for Death (editorial opinion). *Herald Sun*, April 9, 2002, Melbourne.
20. Grzebieta, R., and G. Rechnitzer. Deadly Design (editorial opinion). *Herald Sun*, March 1, 2002, Melbourne.
21. Howard, E. Implementing a “Safe System” Approach to Road Safety in Victoria. Presented at Road Safety Research, Policing and Education Conference, 2004.
22. Mooren, L. The Politics of Road Safety. *Proc., Australasian Road Safety Research, Policing and Education Conference*, 2000, Brisbane.

## SESSION 2: SAFE SYSTEMS

**Real-World Implications of the Safe System Approach**

**J. MARTEN HIEKMANN**  
*PASS CO, Germany*

**SCOPE**

The purpose of this paper is to answer a few questions regarding the implications of passive road safety as follows:

- Implications of passive road safety within the European Union (EU);
- Scope on vehicle restraint systems (VRS) according to European Normative (EN) 1317; and
- The impact of the implications of the safe system approach from a manufacturer's point of view.

**WHAT WAS THE IDEA?**

Due to the creation of the EU, traveling within the EU has become easier and more frequent. The European Commission (EC) set up a program to ensure that road users (drivers and vulnerable road users) of member states had equal quality of passive road safety on roads and highways, regardless of the country where they were driving.

To accomplish this goal, the EC established the following objectives:

- Create a minimum standard for passive road safety, a standard for road restraint systems; and
- Open the EU market to VRS manufacturers without technical trade barriers and national requirements (free trade, "New Approach").

The EC published the Construction Product Directive (CPD 89/106/EEC) in 1988 to standardize testing, performance, and conformity procedures. In 1992, under Mandate M/111, the EC commissioned the European Committee of Standardization (CEN) to provide the technical specifications for road restraint systems (CEN/TC226/WG1). These specifications were published as EN 1317, which declared that a CE mark was obligatory for VRS beginning January 1, 2011.

What did this mean for VRS manufacturers? To meet the obligations mentioned above, manufacturers need to obtain the following for their VRS:

1. Initial type testing (ITT);
2. Factory production control (FPC); and
3. Manufacturer declaration of conformity (MDC).

According to Katsarakis (EC, DG Enterprise and Industry) “by affixing the CE mark, manufacturers indicate that they take responsibility for the conformity of the construction product with the declared performance.”

### **BUT WHO IS RESPONSIBLE FOR THIS?**

In March 2012, a heavy bus accident at Canton Valais, Switzerland, hit the headlines in the EU newspapers ([Figures 1 and 2](#)).

The school bus was on its way back to Belgium from a ski vacation in Switzerland, when the bus driver lost control of the vehicle, crashed twice into the wall, and came to an abrupt stop, crashing the front against a 90° wall in the tunnel.

The tunnel, officially opened in 1999, is 2.500 m long, with two lanes in each direction and is part of Highway A9. In 2005, the ADAC (Allgemeiner Deutscher Automobil-Club) rated the tunnel as “good.”

Twenty-two children, with an average age of 12, and five adults, including the driver, died in that accident. Twenty-four other passengers were injured. These passengers included citizens from Belgium, Netherlands, Poland, and Germany.

No passive road safety precautions, which could have reduced the severity of this accident, were taken in the tunnel.

### **WHAT TO CONSIDER WHEN PLANNING PASSIVE ROAD SAFETY**

Three parties are critical to the passive road safety planning chain:

- Road authorities and road safety planners;
- VRS manufacturers; and
- VRS final assembly design.

This passive road safety planning chain consists of three steps:

- Planning: what product to put where, why, and when?
- Proceeding: correct installation and repair work? Traceability?
- Maintaining: approve and tolerate construction defects?

To avoid defects and errors, the above-mentioned steps need special attention when it comes to VRS. VRS need to be assembled without any interruption, with tested connections and transitions.

To ensure that the system can perform as confirmed by the manufacturer, minimum construction lengths must be taken into account and assembled.

End terminals must be energy absorbing instead of obvious road safety threats.

VRS manufacturers cannot take the responsibility for incorrect installation or defects caused by incorrect assembling ([Figures 3 through 6](#)).





**FIGURE 1 School bus crash Canton Valais, Switzerland, March 2012.**



**FIGURE 2 Bus being removed.**



**FIGURE 3 Barriers not connected.**



**FIGURE 4** Barrier installation is inappropriate.



**FIGURE 5** Use of ramped ends.



**FIGURE 6** Inappropriate post spacings.

**CONCLUSION: JUST DO IT RIGHT FROM THE BEGINNING**

The contemporary implications of the safe system approach show that much more attention was drawn to requirements, specifications, and controlling systems for VRS manufacturers, and less to the responsibilities of other involved parties.

VRS manufacturers can offer high technology solutions and take responsibility for the performance and quality of their systems, according to the norms.

Road planners, authorities, and administrations need to be sensitized to ensure that road users do receive the minimum required passive road safety.

To accomplish this, more attention must be drawn to the installation and assembly of VRS. Special training, approval systems, and employment of confirmed VRS assemblers need to receive more recognition in future.



## SESSION 2: SAFE SYSTEMS

## Improving Roadside Design to Forgive Human Errors

### *Forgiving Roadside Design Guideline*

FRANCESCA LA TORRE  
*University of Florence*

Each year, 43,000 persons are fatally injured in Europe due to road accidents. The RISER project has shown that even though 10% of all accidents are single-vehicle accidents [typically run-off-road (ROR) accidents] the rate of these events increases to 45% when only fatal accidents are considered (Riser, 2006). One of the key issues of this high ROR fatality rate is to be found in design of the roadsides that are often unforgiving. A forgiving roadside design has a limited effect on reducing the total number of accidents (including property-damage-only events) but has a strong impact on crash severity, reducing the number of fatal and injury crashes. Conference of European Directors of Road (CEDR) has identified the design of forgiving roads as one of the top priorities within the Strategic Work Plan. For this reason, a specific team dealing with forgiving roadsides has been established within the CEDR's Technical Group on Road Safety.

According to the RISER project (RISER Consortium, 2006) a roadside is defined as the area beyond the edgeline of the carriageway. There are different opinions and views in literature on which road elements are parts of the roadside and which are not. The roadside can be seen as the area beyond the traffic lanes (or carriageway). The shoulders are thus part of the roadside, since the lane markings define the boundaries. The slopes, the clear zones (also called safety zones), and trees are examples of roadside features that have to be considered by a road designer to make a roadside more forgiving.

A number of different studies have been conducted in recent years to design roadsides to forgive human errors, but there is still a need for

- A practical and uniform guideline that allows the road designer to improve the forgivingness of the roadside; and
- A practical tool for assessing (in a quantitative manner) the effectiveness of applying a given roadside treatment.

IRDES (Improving Roadside Design to Forgive Human Errors) is a research project of the cross-border-funded joint research program ENR SRO1—Safety at the Heart of Road Design, which is a transnational joint research program that was initiated by ERA-NET ROAD—Coordination and Implementation of Road Research in Europe (ENR), a coordination action in the 6th Framework Programme of the European Commission. The funding partners of this cross-border-funded joint research program are the National Road Administrations (NRA) of Austria, Belgium, Finland, Hungary, Germany, Ireland, Netherlands, Norway, Slovenia, Sweden, and United Kingdom. The aim of the IRDES project, completed in November 2011, was to produce a forgiving roadside design guideline and a practical tool for effectiveness assessment with specific reference to a well-identified set of roadside features.

This paper summarizes the content of the guidelines, highlighting the aspects related to barriers terminal and passively safe structures. The full guideline (la Torre, 2011) can be downloaded at [http://www.eranetroad.org/index.php?option=com\\_content&view=article&id=74&Itemid=74](http://www.eranetroad.org/index.php?option=com_content&view=article&id=74&Itemid=74) and will be published in 2012 as a CEDR Report.

## ***FORGIVING ROADSIDE DESIGN GUIDELINE***

### **Structure of the Guideline**

The *Forgiving Roadside Design Guideline* (la Torre, 2011) has been developed as a practical handbook that can be easily used by designers in road safety design projects.

Based on the inputs by the potential stakeholders gathered during the IRDES webinars, the guideline has been structured with each feature analyzed in a separate section providing:

- Introduction,
- Design criteria,
- Assessment of effectiveness,
- Case studies and examples, and
- Key references.

The roadside features for which the IRDES design guideline have been developed are

- Barrier terminals,
- Shoulder rumble strips,
- Forgiving support structures for road equipment, and
- Shoulder width.

One of the issues tackled in the project has been the harmonization of different existing standards or the identification of underlying reasons for different existing solutions for the same treatments in order to allow the user to select the optimal treatment and to properly assess its effectiveness.

The guideline is based on the results of an extensive literature review on forgiving roadsides conducted in the first part of the IRDES project (Nitsche et al., 2010), combined with an additional literature review focused on the specific safety treatments tackled in the guideline.

The different proposed interventions are linked to the potential effectiveness as evaluated in the specific IRDES activity (Fagerlind et al., 2011) as well as in other relevant literature in order to allow the user to perform cost-effectiveness evaluations before planning a specific treatment. Case studies from Fagerlind et al. (2011) are synthesized in the guideline in order to provide examples of applications and best practices.

## **BARRIER TERMINALS**

Safety barrier ends are usually considered hazardous when the termination is not properly anchored or ramped down in the ground or when it does not flare away from the carriageway.

Crashes with unprotected safety barrier ends are often unforgiving as they can result in a penetration of the passenger compartment with severe consequences (Figure 1).

Crashworthy terminals provide a more forgiving barrier end (Figure 2) and can be either flared or parallel, energy absorbing or non-energy absorbing, but in the latter case they have to be properly designed and flared to avoid front hits on the nose of the terminal. The advantage of using flared non-energy-absorbing terminals is that there are usually non-patented terminals that essentially can be installed as a termination of any W-beam steel barrier just by including the design drawings in the safety barriers' detailed construction planning. The most commonly flared non-energy-absorbing terminals are the eccentric loader terminal and the modified eccentric loader terminal (Figure 3).

The decision to use either an energy-absorbing terminal or a non-energy-absorbing terminal should therefore be based on the likelihood of a near end-on impact and on the nature of the recovery area immediately behind and beyond the terminal. When the barrier length of need is properly defined and guaranteed, and the terminal is therefore placed in an area where there is no need for a safety barrier protection, it is unlikely that a vehicle will reach the primary shielded object after an end-on impact regardless of the terminal type selected. Therefore if the terrain beyond the terminal and immediately behind the barrier is safely traversable a flared terminal should be preferred.

If, for local constraints, the proper length of need cannot be guaranteed or if the terrain beyond the terminal and immediately behind the barrier is not safely traversable, an energy-absorbing terminal is recommended.

Turn-down terminals, or flared-degraded terminals, which have been commonly used in the last years in several countries, are now often replaced in new designs by flared terminals with no degradation as the longitudinal slide that arises from the degradation to the ground can lead to an overriding of the barrier.

Additional issues to be considered in the terminals design that are addressed in the IRDES guideline are the following:

- The definition of the length of need;
- The configuration of the terminals in the backfills;
- The configuration of the terminals in the medians; and
- The configuration of the terminals adjacent to driveways.



**FIGURE 1** Unprotected barrier terminals (la Torre, 2011).



**FIGURE 2 Crashworthy barrier terminals: (a) Tasmania (2004) and (b) Riser (2006).**

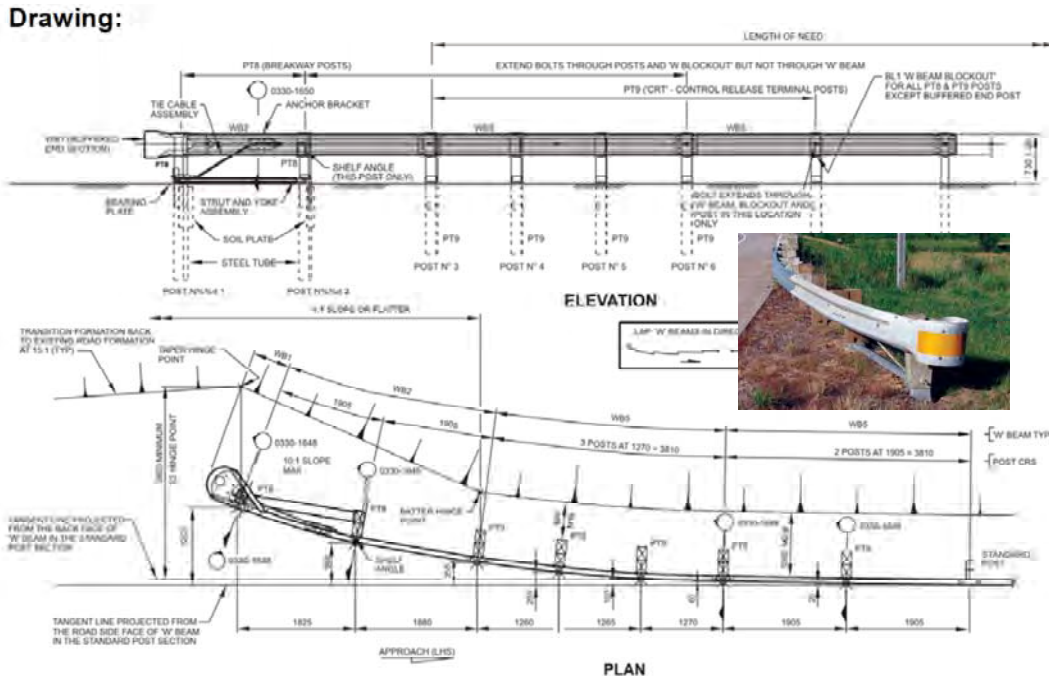

**FIGURE 3 Nonpatented crashworthy barrier terminal. [From Main Roads Washington, website with photo from AASHTO (2011).]**

In terms of effectiveness no before–after studies or crash modification factors (CMFs) are available to account for the number of unprotected terminals on rural single-carriageway roads. This has been developed in the IRDES Project and could be used as a reference (Fagerlind et al., 2011):

$$CMF = e^{0.02381 \times UT}$$



The CMF allows estimation of the potential number of crashes in a section with unprotected terminals (UT) per kilometer of length by multiplying the CMF for the number of accidents expected in the base condition (CMF = 1) that is a segment with no UTs with all the same characteristics as the analyzed one.

Two methods are proposed in the guideline, for evaluating the length of need which defines the first location that needs the barrier's protection. According to the AASHTO *Roadside Design Guide* the length of need can be determined as a function of the roadway design speed and of the average daily traffic (Figure 4). According to the RISER guidelines, the length of need can be defined with reference to a vehicle running off the road with an angle  $\alpha = 5^\circ$  (Figure 5).

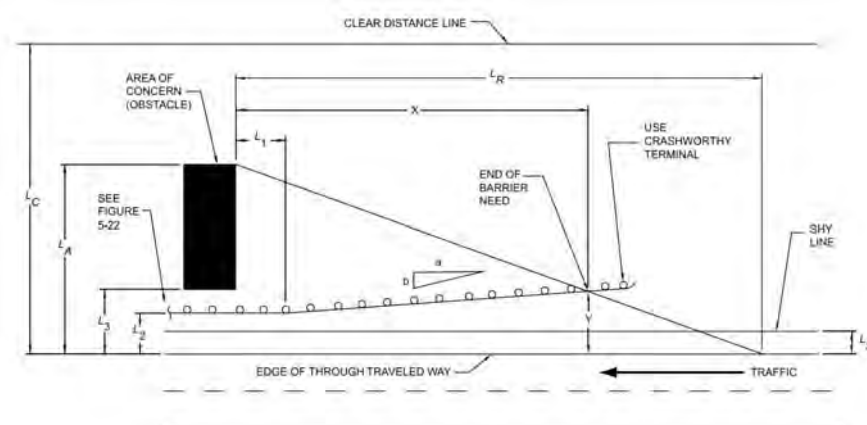

Design Speed (km/h)	Runout Length ( $L_R$ ) Given Traffic Volume (ADT), (m)			
	Over 10,000 veh/day	5,000 to 10,000 veh/day	1,000 to 5,000 veh/day	Under 1,000 veh/day
130	143	131	116	101
110	110	101	88	76
100	91	76	64	61
80	70	58	49	46
60	49	40	34	30
50	34	27	24	21

FIGURE 4 Definition of the length of need, X, according to the AASHTO *Roadside Design Guide* (AASHTO, 2011).

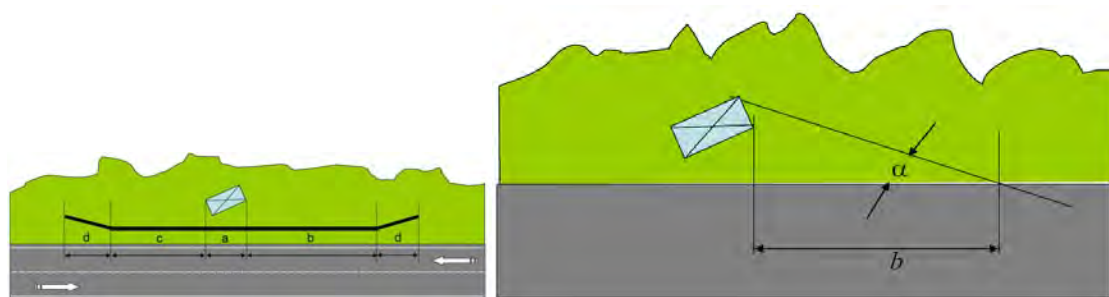

FIGURE 5 Definition of the length of need, b, according to the RISER guidelines (2006).

This assumption leads to values similar to those of the AASHTO *Roadside Design Guide* for almost any obstacle offset for low-speed (50 to 60 km/h), low-volume roads (up to 5,000 vehicles per day). For highly trafficked or high-speed roads the 5-degree angle could lead to underestimating the proper length of need; a site-specific evaluation is recommended by means of the AASHTO approach.

## SHOULDER RUMBLE STRIPS

Shoulder rumble strips have been proven to be a low-cost and extremely effective treatment in reducing single-vehicle ROR (SVROR) crashes and their severity.

For the use of milled rumble strips on rural freeways the CMF has been estimated in Torbc et al. (2010) by combining different studies and resulted in the following:

- CMF = 0.89 (which means potential reduction of crashes of 11%) for SVROR crashes, with a standard error of 0.1; and
- CMF = 0.84 (which means potential reduction of crashes of 16%) for SVROR fatal and injury crashes, with a standard error of 0.1.

For the use of milled rumble strips on rural two-lane roads the CMF estimates are

- CMF = 0.85 (which means potential reduction of crashes of 15%) for SVROR crashes, with a standard error of 0.1; and
- CMF = 0.71 (which means potential reduction of crashes of 29%) for SVROR fatal and injury crashes, with a standard error of 0.1.

Given the very low standard errors these results can be considered extremely reliable in estimating the potential effect of milled shoulder rumble strips on these types of roads.

For urban freeways and multilane divided highways the analysis data available do not yet allow for a statistically sound evaluation of the effectiveness. For multilane divided highways the following values can be used as a best estimate of the effects of milled shoulder rumble strips:

- SVROR crashes are expected to be reduced by 22%; and
- SVROR fatal and injury crashes are expected to be reduced by 51% but more statistically sound research is needed.

Different design configurations have been proposed for milled rumble strips, including the following:

- A more aggressive (and more effective) configuration that can cause higher disturbance to bicycle drivers and to residents in the surrounding area. This type of configuration is recommended when there are no residents in the vicinity of the road and when either a 1.2-m remaining shoulder is available or very limited or no bicycle traffic is expected.
- A less aggressive configuration that is more bicycle friendly and reduces the noise disturbance in the surrounding.

More details on the design of shoulder rumble strips and on the evaluation of their effectiveness are given in the guideline.

## FORGIVING SUPPORT STRUCTURES FOR ROAD EQUIPMENT

This section of the guideline addresses the issue of identifying potential hazards in the roadside and defining the most appropriate solutions for making the hazard more forgiving. It is frequently heard among designers and road managers that obstacles in the roadside need to be protected with safety barriers. This is a simplistic approach that should be overcome to reach a forgiving roadsides design approach as placing a barrier (with its length of need and its terminals) is not necessarily the most forgiving solution and it can be extremely costly as compared to the achieved benefits.

In the IRDES Guideline, the procedure developed in the RISER Project has been proposed and implemented. This requires identifying if the obstacle can be considered a hazard, which means if it is within the clear zone and if it has structural characteristics that can lead to injuries to the occupants of an errant vehicle impacting against the obstacle. As a matter of fact, not all the structures placed within the clear zone are a hazard for an errant vehicle. Among the different criteria to define a hazard available in the literature the approach proposed by SETRA (2007) has been selected as it defines the potential dangerousness based on the stiffness of the structure and not on its shape. According to this approach, a structure can be considered as a hazard if the resistant moment is above  $5.7 \text{ kN}\cdot\text{m}$  and if the structure is not passively safe.

Support structures that have been tested according to European Normative (EN) 12767 standard (Figure 6) are considered to be passively safe or forgiving but different performance classes are given in the EN standard and guidelines for selecting the most appropriate performance class in different situations are given in the IRDES Guideline based on the U.K. selection procedure (Figure 7) (BSI, 2007).



**FIGURE 6** Passively safe support structures (la Torre, 2011).

Situation	Location	Type of support structure		
		Lighting column	Sign or signal support	Non-harmful support structures
Non-built up all-purpose roads and motorways with speed limits > 40 mph	Generally in verges of motorways, dual carriageways and single carriageway roads	100:NE:1-3	100:NE:1-3	100:NE:4
	With significant volume of non-motorised users	100:LE:1-3 or 100:HE:1-3	100:LE:1-3	100:NE:4
	Where major risk of items falling on other carriageways	100:LE:1-3 or 100:HE:1-3	100:LE:1-3	100:NE:4 or 70:NE:4
Built up roads and other roads with speed limits ≤40 mph	All locations	70:LE:1-3 or 70:HE:1-3	70:LE:1-3	100:NE:4 or 70:NE:4

**FIGURE 7 Design criteria for passively safe support structures (BSI, 2007).**

Even though these types of passively safe support structures have been in place for several years in several countries, including most of the northern European countries (Norway, Finland, and Sweden) and Iceland, sound statistical analyses of the effectiveness of using these support structures in reducing the severity of crashes were not found. On the other hand, several studies can be found that indicate that crashes against these types of structures rarely lead to severe consequences.

A risk assessment of the potential effect of using passively safe lighting columns and signposts has been performed in the United Kingdom (Williams, 2008) by combining the likelihood of occurrence of different events that can lead to passenger injuries. The risk associated with the use of passively safe or forgiving lighting columns resulted almost eight times lower than the risk associated with conventional unprotected columns. The solution of protecting the column with a safety barrier leads to a risk that is still two times higher than the risk associated to using passively safe columns.

## SHOULDER WIDTH

The width of the outer shoulder (right for most of the European countries) is commonly recognized as an important roadside safety feature as it increases the recovery zone that allows an errant driver to correct its trajectory without running off the road but the effect of enlarging the outer shoulder width in rural roads is clearly positive for narrow shoulders while for larger shoulders this can be more questionable or even negative. The IRDES Guideline provides CMF and predictive functions that can be used for estimating the effect of having shoulder widths below the national standards. For enlarging the shoulders above the national standards a specific risk assessment should be conducted and additional interventions to prevent the misuse of the extra width of the shoulder should be considered (such as using different pavement colors).

For rural single carriageway two-lane roads and for multilane divided and undivided highways consolidated CMF functions can be found in the recently published *Highway Safety*



*Manual* (AASHTO, 2010) while for motorways in open air the effect of the shoulder width is often not found as these road types usually have an outer shoulder width of 2.50 to 3.0 m that has been shown to be the value above which no effect can be seen in crash reduction. For motorways in tunnels, where shoulders are often more narrow and the confinement affects the drivers behavior, a specific safety performance function is given to estimate the effect of having a reduced shoulder width.

Given the fact the national standards usually set the criteria for defining the minimum or standard outer shoulder width, a uniform value was not proposed but the requirements given for rural roads in Austria, France, Italy, and Sweden have been compared, showing that these are very similar for motorways with speed limits of 130 km/h (2.50 to 3.00 m) while more variability is found in the secondary road network with a speed limit of 90 to 100 km/h.

The studied conducted in the IRDES project highlighted that the effect of enlarging the outer shoulder width in rural roads is clearly positive for narrow shoulders while for larger shoulders this can be more questionable or even negative. It is therefore recommended that the CMF and predictive function given above are used for estimating the effects of having shoulder width below the national standards. For enlarging the shoulders above the national standards a specific risk assessment should be conducted and additional interventions to prevent the use of the extra width of the shoulder should be considered (such as using different colors).

More details on the evaluation of the effectiveness of having wider shoulders are given in the guideline.

## CONCLUSIONS

Within the ERANET-funded project, IRDES, a practical and uniform guideline that allows the road designer to improve the forgiveness of the roadside and a practical tool for assessing the effectiveness of applying a given roadside treatment, has been produced with specific reference to the following set of roadside features:

- Barrier terminals,
- Shoulder rumble strips,
- Forgiving support structures for road equipment, and
- Shoulder width.

The study defined sound and practical guidelines to design forgiving barriers terminals but there is still a need for extensive effectiveness studies to evaluate the effect of replacing unprotected (unforgiving) barrier terminals with crashworthy terminals.

Similarly, the use of forgiving support structures for road equipment tested according to EN 12767 standard needs practical guidelines for selecting the proper performance classes that only a few countries have already implemented. In addition, there is a lack of data to provide an estimate of the effect of using this type of structure even though a risk assessment has shown that the potential benefit is higher than protecting the support structure with a safety barrier.

Shoulder rumble strips, on the other side, are proven to be a highly cost-effective intervention that, with proper design, can be suitable also if bicycle traffic is allowed on the road. But within 200 m of the urban areas, milled rumble strips (more effective but more noisy and

disturbing for the bicycle riding) should be avoided and, if necessary, only rolled rumble strips should be considered.

Finally, the effect of the outer shoulder width on road safety has a well-defined effect but this should be used to assess the effect of having a shoulder narrower than the national design standard for a given road type. The effect of wider shoulder should be evaluated by means of a specific risk assessment as it might encourage drivers' wrong behaviors. Unpaved shoulders effect on safety can be limited, especially in bends.

## ACKNOWLEDGMENTS

The IRDES Team is a Consortium of six EU partners: Università di Firenze (Francesca la Torre, Coordinator, Scientific Responsible, Italy); Chalmers University of Technology (Helen Fagerlind, Scientific Responsible, Sweden); Austrian Institute of Technology (Peter Saleh, Scientific Responsible, Austria); ANAS (Eleonora Cesolini, Scientific Responsible); and IFSTTAR (Yann Goyat, Scientific Responsible, France).

## REFERENCES

- AASHTO. *Highway Safety Manual*. American Association of Highway Transportation Officials, Washington, D.C., 2010.
- AASHTO. *Roadside Design Guide*. American Association of Highway Transportation Officials, Washington, D.C., 2011.
- BSI-EN12767: Passive Safety of Support Structures for Road Equipment—Requirements, Classification and Test Methods. British Standards Institution, U.K., 2007.
- Fagerlind, H., J. Martinsson, P. Nitsche, P. Saleh, Y. Goyat, F. la Torre, and A. Grossi. Guide for the Assessment of Treatment Effectiveness. ENR SRO1 – ERANET Project IRDES – Deliverable N. 2, 2011. Available at [http://www.eranetroad.org/index.php?option=com\\_content&view=article&id=74&Itemid=74](http://www.eranetroad.org/index.php?option=com_content&view=article&id=74&Itemid=74). Accessed Aug. 5, 2012.
- FHWA. Technical Advisory—Shoulder and Edge Line Rumble Strips. T5040.39. FHWA, U.S. Department of Transportation, 2011.
- la Torre, F. Forgiving Roadside Design Guide. ENR SRO1 – ERANET Project IRDES – Deliverable N. 2, 2011. Available at [http://www.eranetroad.org/index.php?option=com\\_content&view=article&id=74&Itemid=74](http://www.eranetroad.org/index.php?option=com_content&view=article&id=74&Itemid=74). Accessed Aug. 5, 2012.
- Mainroads. Available at <http://www2.mainroads.wa.gov.au/NR/mrwa/frames/Standards/standardsr.asp?L=/Internet/Standards/Pavements/default.asp&G={E582C897-FF5E-4C02-8B46-51E88C1E5DD8}&T={1532D87F-C1AC-4386-9968-5E5F4FD002E5}>. Accessed Feb. 22, 2011.
- Nitsche, P., P. Saleh, and M. Helfert. State of the Art Report on Existing Treatments for the Design of Forgiving Roadsides. ENR SRO1–ERANET Project IRDES–Deliverable N. 1. 2010. Available at [http://www.eranetroad.org/index.php?option=com\\_content&view=article&id=74&Itemid=74](http://www.eranetroad.org/index.php?option=com_content&view=article&id=74&Itemid=74). Accessed Aug. 5, 2012.
- Nitsche, P., R. Stütz, P. Saleh, and P. Maurer. A Simulation Framework for Assessing the Safety Effects of Soft and Hard Shoulders as Examples of Forgiving Roadside Treatments. Presented at TRA Conference, Athens, Greece, 2012.
- Nitsche, P., R. Stütz, and M. Helfert. Simulation-Based Assessment of Forgiving Roadside Treatments. *Advances in Transportation Studies—An International Journal*, Special Issue 2011, 2011, pp. 87–98.
- RISER Consortium. D06: European Best Practice for Roadside Design: Guidelines for Roadside Infrastructure on New and Existing Roads. RISER Deliverable, 2006.

- SETRA. Guidelines—Handling Lateral Obstacles on Main Roads in Open Country. SETRA, France, November 2002 (translated August 2007).
- Road Hazard Management Guide*. Tasmania Department of Infrastructure, Energy and Resource, Australia, 2004.
- Torbic, D., L. Eleftheriadou, and M. El-Gindy. Development of Rumble Strip Configurations That Are More Bicycle Friendly. In *Transportation Research Record: Journal of the Transportation Research Board, No. 1773*, Transportation Research Board of the National Academies, Washington, D.C., 2001, pp. 23–31.
- Torbic, D., J. Hutton, C. Bokenkroger, K. Bauer, E. Donnell, C. Lyon, and B. Persaud. Guidance on Design and Application of Rumble Strips. In *Transportation Research Record: Journal of the Transportation Research Board, No. 2149*, Transportation Research Board of the National Academies, Washington, D.C., 2010, pp. 59–69.
- Williams, G. L., J. V. Kennedy, J. A. Carroll, and R. Beesley. The Use of Passively Safe Signposts and Lighting Columns. Transport Research Laboratory, United Kingdom, 2008.

## SESSION 2: SAFE SYSTEMS

**END Turned-Down ENDS****MIKE DREZNES***International Road Federation*

**R**oad authorities worldwide recognize that the most dangerous part of a longitudinal barrier is the end. Understanding the importance of a safe barrier end, researchers have developed a variety of end treatments, or terminals, since their introduction in the 1960s to reduce the dangers of blunt ends.

A crashworthy end treatment must be able to act as an anchor to redirect an errant motorist during an impact near the upstream or nose of the barrier. Therefore, it must be very strong.

However, crashworthy end treatments also must act like a cushion to reduce the deceleration of an errant motorist who inadvertently impacts the end of the barrier head on without ramping, rolling, or pitching. Therefore, the end treatment must also be soft with the ability to cushion an errant motorist.

This creates an engineering challenge and the highway safety engineering community has responded in a very positive manner over the past 50 years.

In the 1960s the best solutions were “fishtails” or “spoons” that were designed to distribute the impact across a wider section of the vehicle (**Figure 1**).

While these fishtail or spoon terminals were an improvement over blunt ends, they were spearing vehicles or driving engines into the backseats of cars (**Figure 2**). They were killing and maiming people on the roads around the world.

In the late 1960s, researchers sloped the ends of the barrier into the ground to create turned-down end terminals or “Texas twists.” While these terminals did prevent spearing, they were causing impacting vehicles to roll, flip, or launch, resulting in serious injuries or fatalities (**Figures 3 and 4**).

In 1990, the FHWA prohibited the use of turned-down end, fishtail, or spoon terminals on the upstream end of barriers located on roads with speeds in excess of 80 km/h and more than 6,000 average daily traffic (ADT) (high-speed, frequent-use roads). In 1998, because turned-down end, fishtail, or spoon terminals could not pass the *NCHRP 350: Recommended Procedures for the Safety Performance Evaluation of Highway Features* criteria, they were prohibited for use on the National Highway System in the United States regardless of design speed or ADT.



**FIGURE 1** Typical fishtail or spoon terminal.



**FIGURE 2 Unacceptable fishtail terminal performance.**



**FIGURE 3 Turned-down end launching vehicle.**



**FIGURE 4 Vehicle after impact with turned-down end.**



Other countries, including England, Sweden, Australia, New Zealand, and Israel, also implemented plans to eliminate the use of these dangerous terminals on the approach ends of concrete barriers or steel beam guardrails on roads with operating speeds in excess of 80 km/h unless these ends are outside the defined clear zone and in other locations where end-on high-speed impacts are unlikely to occur or otherwise shielded from potential impacts. At these sites, these road authorities are requiring the use of crashworthy terminals ([Figure 5](#)).

A variety of these crashworthy terminals that have been tested to the NCHRP 350, AASHTO's *Manual for Assessing Safety Hardware* (MASH) criteria, or to the European Norm (EN) 1317-4 criteria are commercially available today. Their expanded use is encouraged.

Unfortunately, turned-down end, spoon, and fishtail terminals continue to be used at speeds over 80 km/h in countries around the world ([Figures 6 and 7](#)). Too often road authorities or design engineers simply look at the previous project and use the same drawings for the new project. This “way we have always done it” mentality needs to change.



**FIGURE 5** Examples of crashworthy terminals.



**FIGURE 6** Spoon terminal in South America.



**FIGURE 7 Turned-down concrete terminal in Middle East.**

On January 24, 2011, a global group of road safety experts, who met at a meeting of the TRB Roadside Safety Design Subcommittee on International Research, introduced the “END Turned-Down ENDS” resolution that was designed to eliminate the use of outdated and ineffective noncrashworthy, longitudinal barrier terminals like fishtails, spoons, or turned-down ends. This resolution of the expert road safety group was endorsed by the International Road Federation in Washington on March 23, 2011.

The END Turned-Down ENDS resolution reads as follows:

“Turned-Down Terminals were developed and introduced in the 1960s to eliminate sparring of the rail into the passenger compartment of the impacting vehicle that often occurred with the “Fishtail” or “Spoon” full height, stand-up ends. While Turned-Down Terminals were an improvement over the “Fishtail” or “Spoon” Terminals, both field experience and full scale crash testing have shown that vehicle roll over or launching is likely with Turned-Down Terminals under high speed impact conditions.

Based on observed crash test performance and reported field experience, it is recommended that road authorities in all countries immediately prohibit new installations of “Fishtail” or “Spoon” Terminals as well as Turned-Down Terminals on the approach end of concrete barriers or steel beam guardrails on roads with operating speeds in excess of 80 km/h unless these ends are outside the defined clear zone and in other locations where end-on high speed impacts are unlikely to occur or otherwise shielded from potential impacts.

It is understood that system-wide replacement of existing Turned-Down Ends or Fishtail or Spoon Terminals, while beneficial, may not be practical or economically feasible. For new Terminal installations at these locations road authorities should only specify the use of crashworthy Terminals that have met appropriate testing criteria such as NCHRP 350, MASH or EN 1317 (or their updates). During any road construction Restoration, Rehabilitation and Resurfacing Projects (3R), existing Terminals should be updated with Terminals that meet NCHRP 350, MASH or EN 1317 (or their updates) criteria.

Turned-Down Terminals and Fishtail Terminals remain appropriate for trailing (downstream) ends of traffic barriers on divided highways and in other locations where end-on high speed impacts are unlikely to occur.”

One objection by many road authorities to the implementation of tested state-of-the-art crashworthy terminals and the disuse of fishtails, spoons, or turned-down ends is the economic effect if all terminals had to be updated at one time. The appropriate implementation plan, and the plan utilized in the United States, England, Israel and Australia, would be to install crashworthy terminals on new projects and to upgrade the terminals during any major road construction projects such as restoration, rehabilitation or resurfacing projects. A systemic program could be developed to treat the other terminals based on their location, accident history, ADT, and design speed.

To put a face on the dangers of turned-down ends, meet Mark Noel. Mark Noel was a typical 16-year-old teenager living in Maryland. On August 24, 2008, a group of teens from Mark's church youth group were going to a surprise birthday party for one of his friends.

Mark was a passenger in a two-door Honda Civic. They were traveling on a rural road, when a piece of farm equipment identified by witnesses as "large and wider than the road" was encountered on a curve. The passenger side of the automobile was forced off the road, subsequently hit a turned-down end terminal at the end of the guardrail and was ramped into a tree just at the end of the guardrail (Figure 8).

The driver sustained minor lacerations, bruises, short-term memory loss, and trauma. Mark's injuries included a sheering of half his brain stem, bruising to the front, and multiple bleeding throughout the brain, as well as a broken right femur and lacerations. Mark remained in a coma for 4 months. Two weeks after the accident, doctors determined that due to the sheered brain stem, Mark's organs would eventually shut down and that he would die.

Fortunately, Mark did live, but not without life-changing injuries (Figure 9). Mark had surgery that was required to repair his right foot that toned straight. Mark is now considered permanently disabled with traumatic brain injury. Mark cannot walk nor feed himself. All daily functions require assistance. While Mark attends school in a specialized program, he is placed at an elementary learning level.

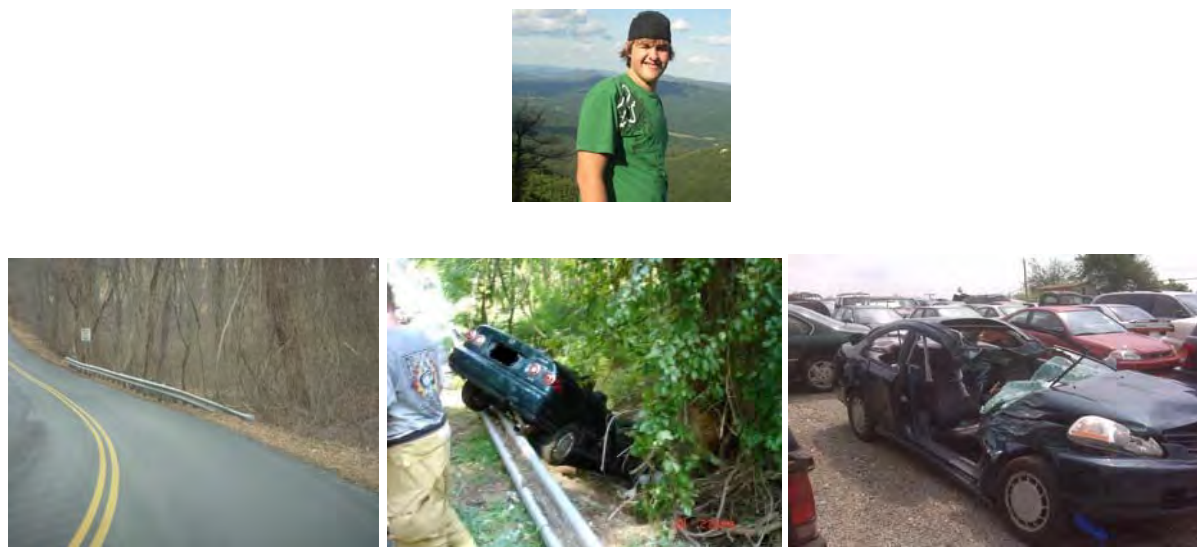

**FIGURE 8** Mark Noel's crash.



What was the financial cost of not continuing the guiderail further up around the curve and using a crashworthy end treatment? What were the costs of shock trauma? Consider the cost of three different rehab facilities and regular doctor visits. More than US\$1 million were spent on Medi-Vac and emergency responders. The costs of attorney fees were horrendous. Instead of working and paying taxes, Mark will be receiving government social benefits for the remainder of his life. He will not be driving a car that would provide fuel taxes to pay for road building and improvements.

Would extending the guiderail another 20 ft (6 m) and using a crashworthy end treatment have made a difference (Figure 10)? Would this have been a more cost-effective option for this location, given the human toll on top of the medical costs? The answer is obvious. It is time to end the use of non-crash-worthy terminals.

On March 2, 2010, the United Nations adopted a resolution pledging to take action to tackle the global public health epidemic of road deaths. More than 1,300,000 people die every year on the roads around the world. The United Nations called for a “Decade of Action for Global Road Safety,” from 2011 to 2020 with a goal of reducing by 50% the projected increase in road traffic deaths by 2020. Eliminating the use of non-crashworthy terminals like turned-down ends, fishtails, and spoons would be a tangible, positive step to make the roads safer around the world and to help the Decade of Action meet its goal to reduce traffic fatalities by 50%.



**FIGURE 9** Mark Noel after his crash.

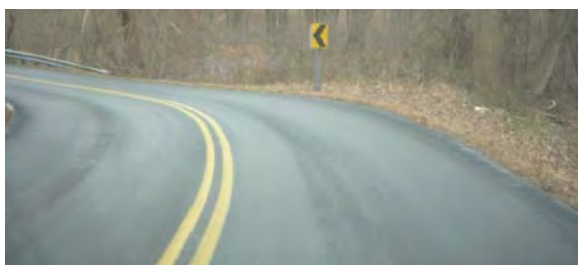

**FIGURE 10** Potential solution by extending the guardrail.

Talk is cheap. The Decade of Action must be a Decade of Change as road authorities and design engineers recognize the new technologies that are available to them, including crashworthy end terminals, and they start to use them on a large scale. Consider that approximately 30% of the fatalities on the road are single-vehicle, nonpedestrian accidents. Road authorities and users would benefit from a mandate to use proven, properly tested road safety hardware to make their roads forgiving so errant motorists do not pay for their mistakes with serious injuries or worse. The motorists expect a safe road and they deserve a safe road.

## SESSION 2: SAFE SYSTEMS

## END Turned-Down ENDS

### *How the United Kingdom Accomplished It*

**STEVE POWELL**  
*Highway Care Limited*

The presentation will look at how the U.K. government roads body, the Highways Agency (HA), moved from the use of barrier terminal ramped ends to the use of European Normative (EN) 1317-compliant P4 terminals on roads with a posted speed limit of 50 mph or greater.

Terminations of safety barrier in the United Kingdom initially involved the use of full height or fishtailed barrier ends. The U.K. performance standard TD 19/85 progressed from allowing these to the mandatory use of ramped ends. All of the barriers at this time were nonpropriety-type systems designed by the U.K. government.

Energy-absorbing barrier end terminals had been in use in the United States for a number of years, however, these were not considered for use by the HA because they used wooden rather than steel posts. It was also considered a problem that there was no European performance standard.

In 1996 a new high-profile motorway was planned in Italy, the Autostrada del Brennero. Many new, innovative systems were designed to be used on this project, including energy-absorbing end terminals with steel posts that meet the requirements of EN 1317-4 at test level P4 (110 km/h).

Shortly after this Highway Care Limited introduced a P4 Terminal to the United Kingdom and began the process of gaining approval for its use by the HA on the Trunk Road Network.

Recognizing the publication of EN 1317 Part 4, the HA replaced TD19/85 with the Interim Requirements for Road Restraint Systems (IRRRS), although this document only specified P1 Performance Class (one test with a 900-kg car at 80 km/h) for terminals on all roads.

Discussions with the HA were ongoing for a couple years, persevering with many different departments as well as efforts being made to gather all available information relating to vehicle impacts involving ramped ends. Presentations were also made to road design engineers and offers of systems free of charge for trial sites. The HA would still not allow its use on the U.K. roads for the following reasons:

- There was no real evidence of ramped ends being hit. The reporting of accidents on the road network generally did not give exact locations. Without this specific information it was difficult to build records of ramped-end accidents. Around this time there were a number of fatal accidents involving ramped ends that attracted media attention; this did show that the consequences of impacting ramped ends at high speed were likely to be severe.
- Concern that with more than 30,000 ramped ends if only some were replaced with P4 terminals that the agency would leave itself open to liability issues. This was proven not be a justifiable reason; as long as a program is undertaken within given financial constraints then it is okay. To do nothing because you cannot do everything at the same time is not an excuse.

- Cost of P4 terminals. Prior to P4 terminals the only energy-absorbing systems available were crash cushions, these are generally much more expensive than ramped ends, however it was shown that the cost of supply and installation of P4 terminals was not much more than ramped ends.

These points were debated and around the same time a number of other important factors assisted with progress:

- A number of fatal accidents involving ramped ends occurring and being reported in the media.
- The acceptance by the HA that current systems being installed on U.K. roads were nonproprietary systems that had not been tested and were unlikely to meet the requirements of EN 13117-4.
- External media pressure. Press articles and a television motoring program, *Fifth Gear*, running a feature video article.
- Pressure from other manufacturers that were able to supply P4-compliant products.
- Finding someone in the HA to recognize and utilize innovation.

Eventually there was a breakthrough moment. At the U.K. road industry trade show Traffex in 2003, a senior member of HA saw the product and understood that 110-km/h P4 terminals would offer better protection than ramped ends. A trial location on the M4 motorway was agreed and the first P4 terminal was installed on September 26, 2003 (Figure 1).

The use of P4 terminal had been accepted and, in December 2004, IRRRS was revised, making it mandatory for roads with a speed limit of greater than 50 mph to have terminals that face oncoming traffic to be compliant to EN 1317-4 with a performance class rating of P4.

In 2006, the IRRRS was incorporated into the new U.K. performance standards TD 19/06: Requirement for Road Restraints, part of the *Design Manual for Roads and Bridges*.

To date, there are more than 6,000 P4 terminals installed in the United Kingdom, supplied by a number of manufacturers.



**FIGURE 1** Crashworthy terminals.

## SESSION 2: SAFE SYSTEMS

## End Treatments of Safety Barriers *Best Practices and Challenges in Germany*

UWE ELLMERS

*Federal Highway Research Institute, Germany*

The use of road restraint systems along the roads has a long tradition in Germany. Mostly you will find steel guardrails although concrete barriers are installed more and more. Each guardrail has a beginning and an end, unless there is a closed line in the median. These parts of a system are critical because it is difficult to ensure the whole containment capacity at that point. Furthermore, it should not create a hazard to impacting vehicles. But the beginning and the end of road restraint systems can also have the function of an anchorage. It is obvious for a country like Germany, where safety plays an important role, that national design guidelines for road restraint systems are covering also these parts of a road restraint system.

In the old regulation from 1989 (1), Germany already forbade using blunt ends like fishtails or spoons because they are regarded as dangerous. This knowledge came from accidents that have happened in several countries. So Germany decided to turn down and flare the beam of the steel guardrail to the ground over a distance of 12 m. In exceptional cases where space is limited it could be done within 4 m. At that time no impact tests have been required on these systems.

These systems were used in Germany for decades. Although there is no specific accident statistics, the experiences were generally positive.

In the late 1980s and early 1990s, the activities of standardization on the European level started. At that time impact tests were required as a proof of the correct function of road restraint systems. On behalf of the Ministry of Transport's Federal Highway Research Institute (BAST) conducted around 80 impact tests on road restraint systems taking into account the requirements of the new European Normative (EN) 1317. Parallel to this the national design guideline RPS 2009 (2) was newly set up.

The new guideline has been valid since 2010. It is completely free of systems, meaning it is functional based. This was done to be fully in line with international regulations.

Some requirements for terminals are included as well. Terminals must fulfill class PA2 of ENV 1317-4 (or EN 1317-7). They should be placed in areas without obstacles or hazards because gating terminals are not supposed to contain vehicles. On the other hand they must not be a hazard itself. So according to the German guideline they are located in hazard-free areas. If it is possible they should be flared into the edge of the road. In general, terminals should be installed in areas where they can be crossed over (gate) or, in the case of a vehicle riding up onto the nose of the terminal, there should be no obstacle close to the nose. The guideline demands a minimum of 80-m length in front of an obstacle, which is close to the guardrail so that it cannot be hit by a vehicle riding up onto the nose.

To ensure the use of safe systems, BAST has conducted several impact test on terminals used in Germany. The results are published in BAST Report No. V57. We learned that turned-down ends with a length of 4 m do not function well so they do not fulfill the new guideline.

Whereas the tests on the 12-m turned-down end worked satisfactory for class P2 and can be used in Germany as a common terminal for steel guardrails.

To improve the situation, BAST has recently conducted another head-on test according to ENV 1317-4 with a turned-down end terminal of 16-m length and a speed of 100 km/h. This test was successful so there is a good chance to have also a terminal in class P3U in the future.

Taking into account that the Part for Terminals of the EN 1317 is now being voted on by all member countries, further testing will be done when the standard has become harmonized.

A country like Germany has the obligation to install safe road equipment on its roads. To fulfill this obligation, first we need initial-type testing. The systems have to prove their crashworthiness in practice before being installed on the roadside. In this sense, crashworthiness means they have to work well (safely) in nearly all circumstances.

Dealing with safety always means that there is a remaining risk for the user of the road, which cannot be avoided. It is always possible that the circumstances of an accident will lead to an unknown or unexpected behavior of installed safety devices. This should be monitored. If the conclusion is that it was just bad luck, nothing reasonable can be done to improving the situation. If there is a systematical error in the system the road authority has to take action. There are several examples in Germany where this can be seen. Monitoring is done in Germany by accident investigations and gathering and sharing experiences during meetings within the national road authority organization. There is a big accident database available with all registered accidents in Germany. In the database you can choose the attribute "road restraint system." Unfortunately, it is not possible to abstract terminals. This can only be done in a detailed accident investigation. On behalf of the Ministry of Transport, the German In-Depth Accident Study was started in 1999 and continues to the present (for more information see [www.gidas.org](http://www.gidas.org) or [www.bast.de](http://www.bast.de)).

Looking at accidents that have occurred in Germany on terminals, one will find only few cases and very different ones. In general we find that terminals which are installed in accordance to our national guidelines cannot be regarded as an unsafe device. We have some accidents in our database showing that it is possible to cross the turned-down end, to ride on it, or to be retained. There are very few cases where there is an overturning with severe outcome.

To conclude, from the point of view of BAST, we regard turned-down ends positively tested in accordance to ENV 1317-4 or in future EN 1317-7 as the best practical solution for a wide use on our roads to begin and end a steel guardrail. In addition they ensure the function of the anchorage of the system so that the containment (or redirection) is provided close to the anchorage.

## REFERENCES

1. *Richtlinien für passive Sicherheit (Guidelines for Passive Safety)*. RPS, 1989.
2. *Richtlinien für passiven Schutz an Straßen durch Fahrzeug-Rückhaltesysteme (Guidelines for Road Safety with Regard to Road Restraint Systems)*. RPS, 2009.



SESSION 3

**Best Practices**





## SESSION 3: BEST PRACTICES

## Best Practices and Strategies to Reduce Fatal or Serious Injury Crashes into Guardrail Posts by Motorcyclists *United Kingdom Experience*

GAVIN WILLIAMS

*Transportation Research Laboratory, UK*

This paper examines the background to the use of motorcyclist protection systems (MPS) within the United Kingdom by first presenting a case study of the first MPS installation in the United Kingdom. This installation increased awareness of the use of MPS systems within the United Kingdom and this, together with discussions from motorcyclist organizations and enquiries through Parliamentary Questions, persuaded both the Highways Agency (HA) and Transport Scotland to initiate research into incidents between motorcyclists and safety barriers. This paper presents the results of this research, and explains how this research may lead to implementation guidelines for future MPS use in the United Kingdom.

The first installation of a motorcyclist protection device (MPS) in the United Kingdom was in March 2004 at the A2070 Cloverleaf Junction, Kent. This MPS was installed on both tensioned corrugated beam (TCB) and open box beam (OBB).

Cloverleaf Junction is a combination of bends linking the A2070 dual carriageway, part of the Ashford Southern Bypass, to the A2070 Hamstreet Bypass, a single-carriageway link to the A259 at Brenzett (Figure 1). The area is notorious for vehicles, particularly high-speed motorcycles. A handover meeting between Kent Highways, Ashford Highways, and InterRoute, a HA local area team, identified an existing problem at the Cloverleaf Junction with numerous fatalities and serious incidents mostly involving motorists losing control and colliding with the support posts of the safety barrier.

Furthermore, at a coroner's inquest into a fatal incident in August 2002, the coroner instructed the local highway authority to undertake such measures as to prevent the likelihood of further incidents of this nature and severity from re-occurring.

In the 5 years prior to the installation, 14 motorcyclist casualties had occurred at the location (three fatalities, eight serious, and three slight injuries). All of the incidents occurred in dry conditions during the months between February and September.

A review of MPSs available at the time was then undertaken by the local HA area team. It is worthy of note that the effect of adding the MPS on the performance of the safety barrier was included in the review. A proposal for the addition of a secondary rail was subsequently submitted to HA in January 2004, with approval granted in March 2004. The system was then installed in late March 2004.

As part of the safety improvement scheme, a reduction in speed limit from 70 mph to 50 mph was also introduced.

Since the installation of the system (and the reduction in speed limit) and the end of 2010, no personal injury incidents had been reported at Cloverleaf Junction (Figure 2). Witness marks on the barrier indicate that there may have been one motorcyclist impact with the system during that time.



**FIGURE 1 The Cloverleaf Junction before the installation of the MPS.**



**FIGURE 2 The Cloverleaf Junction following the installation of the MPS.**

This installation increased awareness of the use of MPS systems within the United Kingdom and this, together with pressure from motorcyclist organizations, and enquiries through Parliamentary Questions, drove both the HA and Transport Scotland to initiate research into such incidents. Hence between 2007 and 2008, incident analyses were carried out by the Transport Research Laboratory (TRL) on behalf of HA and Transport Scotland.

A search was made within the Department for Transport's STATS19 database for all incidents reported by the police occurring in England, Scotland, and Wales between 1992 and 2005 on major roads. During this period, there were a total of 1,584,605 incidents, involving 3,029,100 vehicles and resulting in 2,233,288 casualties.

The search showed that the number of motorcycle-to-safety-barrier incidents per year is relatively low; 2,559 incidents occurred between 1992 and 2005 (183 per year), of which

- 19.9 per year are fatal,
- 82.5 per year are serious, and
- 80.4 per year are slight.

This corresponds to the following incident severities:

- 10.8% are fatal,
- 45.1% are serious, and

- 44.0% are slight.

If this is compared to the severity of all motorcycle incidents:

- 2.4% are fatal,
- 24.8% are serious, and
- 72.8% are slight;

all vehicle restraint system (VRS) incidents:

- 2.0% are fatal,
- 13.9% are serious, and
- 84.0% are slight,

and the general severity of all incidents:

- 1.4% are fatal,
- 12.9% are serious, and
- 85.7% are slight.

It can be seen that while the number of motorcyclist incidents are relatively low, the severity of the incident is disproportionately high.

Further examination of the incident data also showed that the riders typically involved in motorcycle-to-safety-barrier incidents are mostly male (92%) and aged between 30 and 59 (60.0%). Most incidents (77.6%) involve no precollision, occur during daylight or on a lit road (84.6%), in fine weather (93.5%; this may be due to more motorcyclists being on the roads during fine weather), on a dry road surface (85.8%).

Whilst the STATS19 incident data give a very-effective way of obtaining general information on injury incidents, further information can be obtained by examining police files relating to fatal incidents. Examination of these files, relating to motorcyclist-to-safety-barrier impacts has shown that at the time of impact with the barrier, 47% of fatalities were in a seated location, 37% were sliding along the carriageway, 12% were not in contact with the ground, and 4% were rolling. So the current testing procedure for MPS, contained within TS 1317-8 (which only looks at the sliding rider configuration) may not be representative of the most common incident scenario identified.

The locations of all 278 fatal incidents were plotted on a map to identify common trends in the location of the incidents. This showed that in 38.5% of cases the barrier was struck on a straight road section; 32.0% occurred on a left-hand bend; 19.1% occurred on a right-hand bend; 6.1% occurred on a slip road; and 3.2% occurred at a roundabout. From the examination of the incident locations it was concluded that median barrier impacts are most likely to occur on a left-hand bend with a large radius, and that verge-barrier impacts are most likely to occur on a right-hand bend with a small radius.

The current HA guidelines for the selection and location of VRSs, TD 19/06, requires that motorcyclist protection be considered for areas with a potentially high risk of a motorcyclist impact, although no methodology is currently provided. However new guidelines are currently being considered by the HA and Transport Scotland.

TRL is currently undertaking work on behalf of the HA and Transport Scotland to update the incident data within the original analysis and this will lead to a further understanding of the issues regarding motorcyclists and VRS. In turn, this may lead to the development of risk assessment methodologies for the installation of MPS. Of course the protection of other road users will also be considered within any decision-making processes

TRL would like to thank the Highways Agency and Transport Scotland for the funding required to carry out this research and data analysis, without which the work is unlikely to have been completed.

## SESSION 3: BEST PRACTICES

## Best Practices and Strategies to Reduce Fatal or Serious Injury Crashes into Guardrail Posts by Motorcyclists

### *Australian Experience*

**RAPHAEL H. GRZEBIETA**

**MIKE R. BAMBACH**

**ANDREW S. MCINTOSH**

*Transport and Road Safety Research*

*University of New South Wales, Sydney, Australia*

### BACKGROUND

The role of roadside safety barriers in motorcyclist trauma has been an area of concern among motorcyclists, road authorities, road safety researchers, and advocates despite the number of barrier-related deaths being relatively small. Roadside barriers include safety barriers positioned either at road edges or within medians and are typically steel W-beam, concrete, or wire-rope. As a result, a major research project focusing on motorcycle crashes into roadside barriers in both Australia and New Zealand was started in 2008 (11). This project is now in its final stages at Transport and Road Safety (TARS) Research (formerly the IRMRC) at the University of New South Wales in Sydney, Australia. The results presented in this paper focus on impacts into barrier posts. Presented are extracts from reports and papers already published by the authors elsewhere and listed in the references (1–6, 11–14). The project was funded by a consortium comprised of three road authorities, a third-party injury compulsory insurance authority, and an Australian motoring safety consumer group. (Note: This short paper is a compiled extract of a number of papers by the authors listed under references at the end of this paper.)

The proportion of fatal motorcycle crashes involving roadside barriers is typically small. In Australia, they comprise less than 0.01% of all road fatalities. The following percentages are barrier fatalities as a proportion of all motorcycle fatalities: 5.5% in the United States (9), 6% in Australia (13), 2% in New Zealand (14), and 8% to 16% in Europe (8). However, barriers represent a much greater fatality risk to motorcyclists than to car occupants; 15 times in Europe (8) and 80 times for steel guardrails in the United States (9). Gabler (9) determined that 12% of motorcycle–guardrail collisions were fatal and 7.9% of motorcycle–concrete barrier collisions were fatal. The fatality risk for motorcycle–guardrail collisions was found to be 2.5 times that for motorcycle–car collisions. Selby (19) found that of non-urban motorcycle crashes in New Zealand between 2001 and 2005, 6.4% of motorcycle–barrier crashes were fatal, which was slightly less than the fatal rate of 7.3% for crashes that did not involve a roadside object. Ouellet (15) found that in the United States, 30% of motorcyclists that impacted a guardrail received at least one ASI3+ injury (Accident Severity Index).

### DATA COLLECTION AND ANALYSIS

The methodology of how the data were collected and analyzed is described in two reports by Bambach et al. (1) and Grzebieta et al. (11). Roadside fatalities involving a motorcycle were

identified in the Australian National Coroners Information System (NCIS) and the Crash Analysis System (CAS) of the New Zealand Transport Agency for the 5-year period between 2001 to 2006 as inclusive. A total of 1,462 roadside motorcycle fatality cases were identified. Of these, 78 were positively identified as involving a roadside safety barrier. The police reports contained a varying amount of information. However, as per police procedure for fatal crashes in most cases, police crash team investigators were in attendance at the crash scene. Scene photographs were available in 66 case files; measurements of the crash scene were documented in 62 cases (skid or scrape mark lengths, location of impact points, resting positions of motorcycle and motorcyclist, and any parts thereof, etc.); the pre-crash speed of the motorcycle was estimated in 54 cases; and scene diagrams produced from a surveying instrument were included in 14 cases. Many cases also included witness accounts and statements from police attending the scene (11–14).

The rigid upright posts of some barrier systems have been previously noted to be particularly harmful to motorcyclists (15, 16). Thus, in the present study, the involvement of posts was documented. Post impacts were determined in the files from the on-scene crash investigators reports of markings and in some cases were additionally complemented by witness statements. Such markings include one or more of blood or human tissue on posts, helmet scrape marks on posts, clothing material caught on posts, imprints left in helmets matching post markings, or motorcyclist position when found (1, 2).

The crash modes are summarized in Figures 1 and 2, along with the motorcyclist kinematics and the occurrence of motorcyclist impacts with barrier posts and barrier types (1, 2). There were 34 confirmed post impacts, predominantly on W-beam barriers. However, two were wire-rope posts and three resulted from signposts located on top of concrete barriers. Of the 34 impacts, 19 were in the upright posture, 13 were sliding, and two were ejected. Of the motorcyclists that impacted a W-beam or wire-rope barrier post, 92% recorded ASI3+ injury to the body region that contacted the post, and 76% recorded a Melasma Area and Severity Index (MASI) rating for the body region that contacted the post. The crash modes in which motorcyclists collided with the barriers were classified into the three categories of upright (37 cases), sliding (34 cases), or ejected (five cases). In two cases the crash mode could not be determined.

In the sliding crash mode the motorcycle falls to the roadway and the motorcyclist and motorcycle slide along the road surface and into the barrier. Witness reports often comment on the fact that the motorcyclist and the motorcycle are separated prior to contacting the barrier in this mode. However a reliable criterion to determine separation could not be established from the case files. The sliding crash mode was further categorized in some cases into cases of low-siding or high-siding. Low-siding involves the motorcycle falling to the roadway on the side of the motorcycle that is on the inside of the corner. High-siding involves the motorcycle being flipped over from the inside of the corner to contact the roadway on the outside side of the motorcycle (opposite to the leaning side). Evidence of the motorcycle low- or high-siding could be determined in 23 of the sliding cases, from the skid and scrape marks on the roadway or damage to the motorcycle (1, 2).

In the upright crash mode the motorcyclist collides with the barrier in the upright posture while seated on the motorcycle. The motorcycle is typically redirected along the barrier. Due to the impact trajectory angle of the motorcycle relative to the barrier, momentum causes the upper body of the motorcyclist to continue over the barrier. In nine cases the motorcyclist was ejected over the barrier upon impact. In 20 cases this momentum and the redirection of the motorcycle along the barrier resulted in the motorcyclist scraping, tumbling, or skidding along the top of the



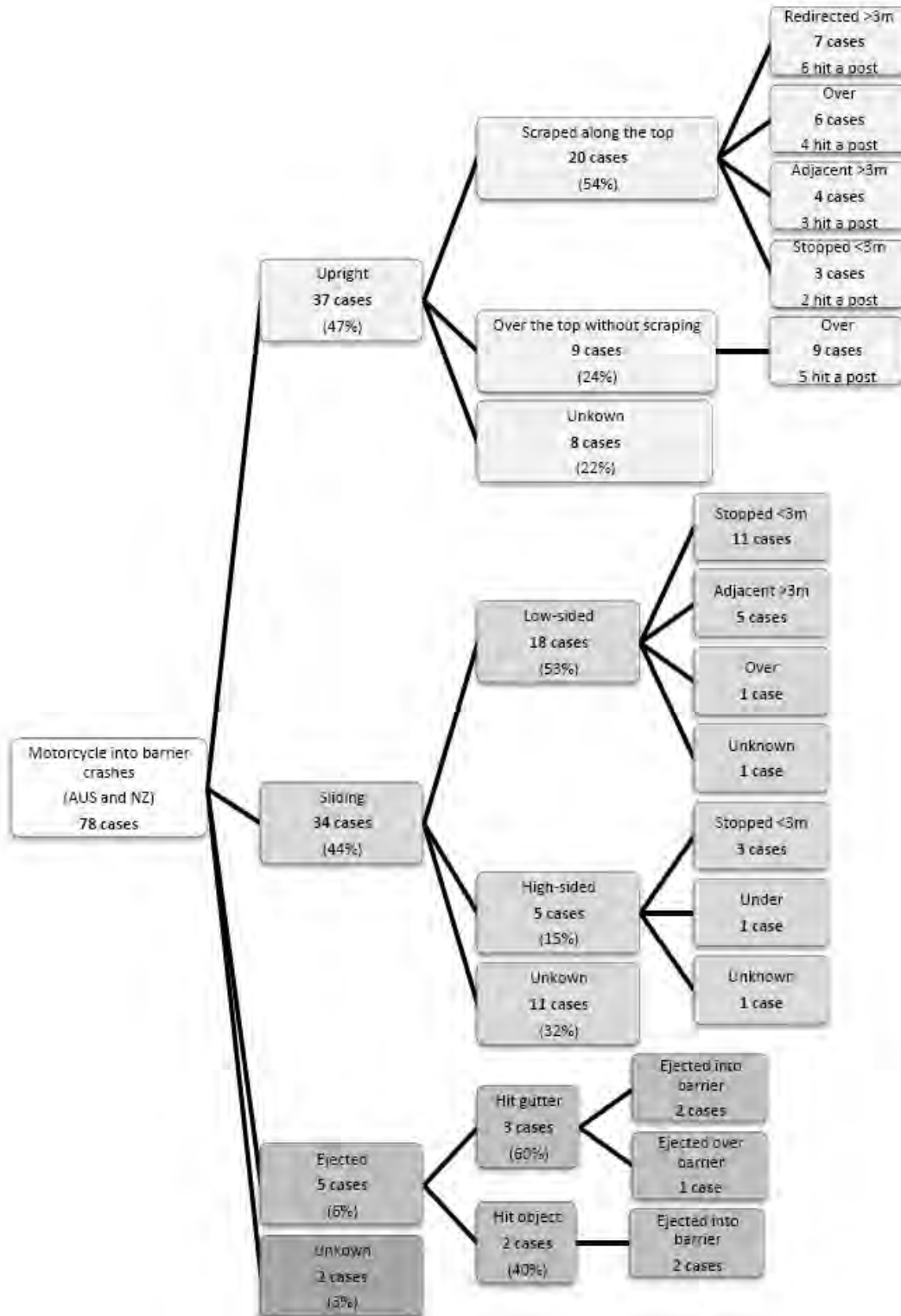

**FIGURE 1 Summary of crash modes, motorcyclist kinematics and post impacts for the 78 motorcycle barrier (1, 2).**

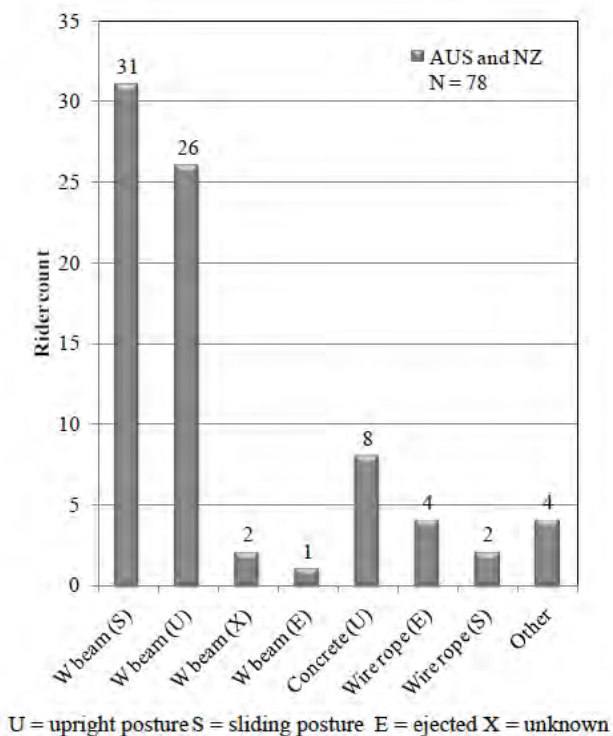

**FIGURE 2 Summary of barrier types and crash postures (1, 2).**

barrier. After scraping along the top of the barrier for some distance the motorcyclist was then ejected from the barrier, and in 15 of the 20 cases this occurred as a result of the motorcyclist impacting a barrier post.

It could not be determined from the case files to what extent the motorcyclist remained in contact with the motorcycle during the process of scraping along the top of the barrier. Some crash tests in the upright mode have shown crash test dummies [anthropomorphic test devices (ATDs)] may separate from the motorcycle during this process (7, 16). In eight cases it could not be determined if the motorcyclist had scraped along the top of the barrier (1, 2).

In the ejected crash mode the motorcycle came into contact with the gutter (three cases) or an object (two cases), and the motorcycle rapidly decelerated, ejecting the motorcyclist forwards from the motorcycle and into the barrier. It is noted that in none of the eight cases where a fatality resulted from a collision with a concrete barrier did the motorcyclist impact in the sliding crash mode (1, 2).

The mean distance the motorcyclist traveled from the impact point with the barrier was 21.8 m (SD = 23.4 m) in all crash modes. Among motorcyclists that impacted the barrier in the sliding crash mode the mean distance was 12.7 m (SD = 20.6 m) and in the upright mode 26. m (SD = 20.4 m). The longer distance covered when in the upright mode results from the momentum retained by motorcyclists as they scrape, tumble, or skid along the top of the barrier. The mean distance motorcyclists scraped along the top of the barrier in the upright mode was 13.9 m (SD = 12.4 m). Given that W-beam posts are typically spaced 2 m apart, this presents multiple opportunities for the motorcyclist to impact with a post, resulting in the high incidence noted in this

crash mode (15 from 20 in Figure 1). The mean distance motorcyclists slid on the roadway prior to impacting the barrier in the sliding crash mode was 28.9 m (SD = 13.8 m) (1, 2).

The mean impact angle in all crash modes was 15.4° (SD = 8.6°), and the mean impact angles for the sliding and upright crash modes were approximately the same. Motorcyclists that went over the barrier tended to have impacted the barrier at angles larger than the mean. Motorcyclists that were redirected tended to have impacted the barrier at angles shallower than the mean, and both results are to be expected when one considers the momentum of the motorcyclist (1, 2).

Figure 3a plots the percentage of motorcyclists that received at least one AIS3+ injury in each body region among the group of motorcyclists that collided with W-beam barriers, and the motorcyclists that collided with W-beams in the sliding posture or the upright posture. While the injury profiles of the two crash postures were similar, thorax and pelvis injuries occurred more frequently among motorcyclists that slid into W-beam barriers. In Figure 3b the injury profiles are compared for the three different barrier types of W-beam, wire-rope, and concrete. The distribution of injuries is quite similar. However, the results must be treated cautiously due to the small datasets for the wire-rope and concrete barriers (five and four cases, respectively) (1, 3).

## IMPLICATIONS FOR MOTORCYCLE–BARRIER CRASH TEST PROTOCOLS

European standards have recently been developed that define methods to evaluate the performance of barriers when impacted by a motorcyclist (17, 20). These standards prescribe crash tests in which an ATD is propelled into a barrier at an angle of 30° at an impact speed of 60 km/h. While the standards recommend ATD head, neck, and thorax instrumentation, only head and neck biomechanical indices are defined for determining the injury severity levels of the barrier crash.

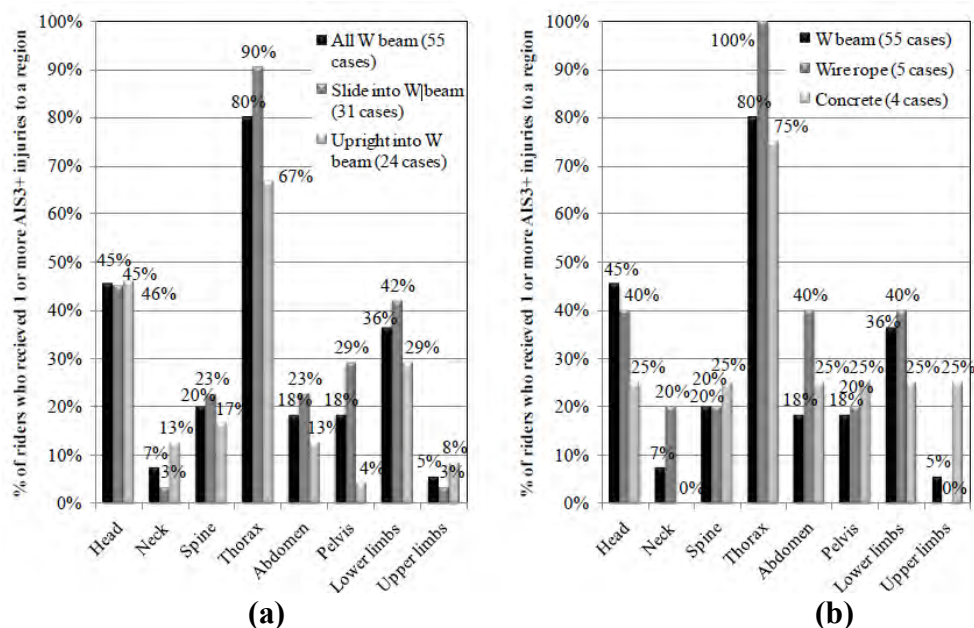

**FIGURE 3** Injury profiles for (a) different crash postures in collisions with W-beams and (b) different barrier types in all crash postures (1, 3).

**TABLE 1 Summary of Crashes in Which the Motorcyclist Was Likely to Be Traveling Around 60 km/h on Impact with the Barrier in the Sliding Posture (I)**

Barrier type	Angle (°)	Barrier impact speed range (km/hr)	ISS	MAIS	MAIS body region(s)	AIS3+ injuries
W beam	--	80*	25	4	Thorax	≥3 ribs fractured, lacerated aorta, ruptured diaphragm, haemopneumothorax, pelvic ring fracture
W beam	--	27-64	75	6	Thorax	≥3 ribs fractured, ventricular rupture of the heart, major haemothorax, major spleen laceration, cerebrum subdural hematoma
W beam	16	49-66	75	5	Thorax, Spine	Bilateral flail chest, perforated heart, haemothorax, cervical cord laceration, lumbar cord laceration
Wire rope	24	32-65	16	4	Thorax	≥3 ribs fractured, major haemothorax
W beam	19	26-63	43	5	Spine	thoracic cord laceration with fracture, haemothorax, intracerebral hematoma, femur fractures
W beam	18	29-66	18	3	Thorax, Lower ext.	≥3 ribs fractured, major unilateral lung contusion, unilateral lung laceration, haemothorax, open tibia shaft fracture
W beam	9	61-82	9	3	Thorax	≥3 ribs fractured, haemothorax
W beam	10	59-83	32	4	Thorax, Upper ext.	≥3 ribs fractured, lacerated aorta, unilateral lung laceration, haemothorax, arm amputation at shoulder
W beam	14	60*	16	4	Thorax	≥3 ribs fractured, bilateral lung contusion, major pneumothorax
W beam	28	46-62	41	5	Abdomen	unilateral flail chest with >5 ribs fractured, major unilateral lung laceration, ruptured diaphragm, stomach, uterus and spleen, renal artery and vein lacerations, major haemothorax
W beam	32	55-77	18	3	Thorax, Lower ext.	≥3 ribs fractured, both femurs fractured

\* pre-crash speed shown since slide measurements were not available

For comparison of injury profiles resulting from conditions similar to those prescribed by these standards, those cases in which the impact speed of a sliding motorcyclist was likely to be around 60 km/h were determined and are presented in [Table 1](#). Lower-bound impact speeds were determined using the lower-bound pre-crash speed and upper-bound drag factor, and upper-bound speeds vice versa, to produce the impact speed ranges listed in [Table 1 \(I\)](#). Among this group of 11 fatally injured motorcyclists there were a total of 31 thorax, six abdominal, six lower extremity, three spine, two head, and one upper extremity ASI3+ injuries. The thorax received a MASI injury in nine of the 11 cases. Since the number of motorcyclists and nature of injuries of motorcyclists that collide with a barrier at this speed and are not fatally injured is unknown, an injury or fatality risk cannot be determined. However, from [Table 1](#) it is clear that such collisions can certainly be fatal, and when motorcyclists were fatally injured in such collisions it was generally from thorax injury rather than head or neck injury.

This has significant implications for motorcyclist–barrier testing protocols. While some researchers have suggested thorax injury criteria, presently none have been adopted due to



concerns regarding the biofidelity of current ATD thoraxes, and inconclusive relationships between measured loads and injury severity (10, 17). Two alternative sliding tests have been provided by the authors in (1). However, more research work needs to be carried out to assess the viability of these alternate scenarios.

Considering that a quarter (20) of the cases (Figure 1) involved an upright rider sliding along the top of the barrier, another test should also be considered in regards to addressing injuries occurring in motorcycle–barrier crashes. Figure 4 shows the top of a standard W-beam barrier where it can be clearly seen how the Charlie posts and block-out protrude above the top of the beam. At high speeds these act as sharp cutting edges much like a hacksaw. An alternative design and test procedure is shown in Figure 5. Beside addressing the measurement of the thorax injury risk, an additional test to the current European test (10, 17, 18, 20) should require that an ATD slide along the top of the barrier as has already been demonstrated by Berg et al. in 2005 (7).

### FURTHER ANALYSIS OF FIXED-OBJECT COLLISIONS USING U.S. DATA

A logistic regression model was developed by the authors (4, 5) where the United States National Automotive Sampling System General Estimates System (GES) was used to determine factors associated with fatalities in single-vehicle, fixed-object motorcycle crashes for the years from 2000 to 2009 (inclusive). The GES provides data about all types of crashes involving all types of vehicles, and is a probability sample that reflects the geography, roadway mileage, population,



**FIGURE 4 W-beam with Charlie post and block-out.**

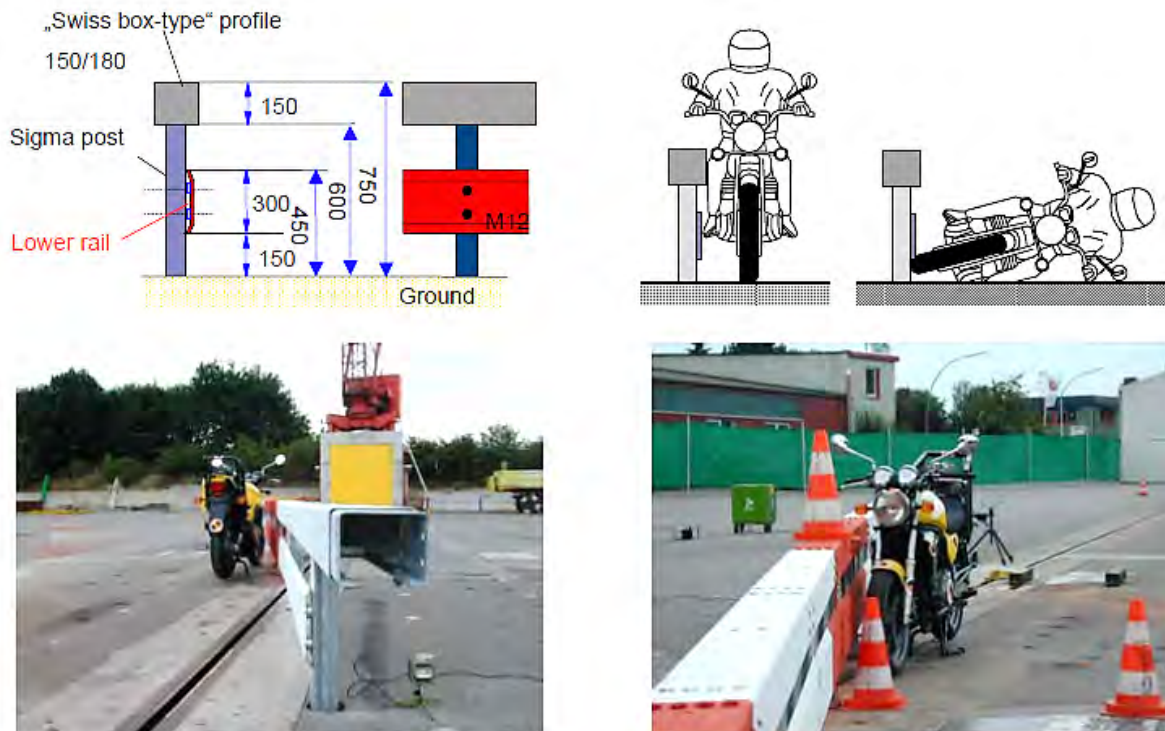

**FIGURE 5** Steel barrier with lower-rub rail and smooth top (6).

and traffic density in the United States. Around 50,000 crashes are sampled each year, including those that result in a fatality or injury, and those involving property damage only. All human, vehicle, and environmental variables were considered as parameters in the model. A dichotomous outcome of fatal (1) or not fatal (0) was used. Model parameters were included based on their significance levels, and parameter estimates were determined from the method of maximum likelihood. Model selection was based on Wald chi-square statistics, Akaike's information criterion and likelihood ratio tests. The log likelihood, Hosmer and Lemeshow goodness-of-fit test, and the area under the receiver operating characteristic curve, indicated that the selected model had good convergence, fit, and predictive power (5).

Figure 6 shows the major outcome from this analysis is that trees and poles were found to be particularly hazardous and more so than barriers. Associations with a fatality risk increased sharply above a travel speed of about 100 km/h. Moreover, a motorcycle traveling at a speed of 100 km/h prior to crashing into a fixed object such as a tree or pole will result in around a 40% probability of a fatality outcome. However, by installing a barrier (of any kind), the probability of a fatal outcome reduces to around 10%.

A further fatality risk investigation compared the statistical model developed in (5) with data from the Fatality Analysis Reporting System (FARS) database. The FARS database is a census of all crashes in the United States of motor vehicles traveling on a traffic way customarily open to the public, which resulted in the death of a motorist or a nonmotorist within 30 days of the crash. The FARS database was queried for the years from 2000 to 2009 (inclusive), to determine all fatal motorcycle rural roadway departure collisions with trees and utility poles. These cases were identified in the database when they satisfied the following conditions: the roadway function class was defined as rural (rural arterial, rural collector, rural local road or

street, or rural unknown); the vehicle body type was a motorcycle; the crash was a single-vehicle crash; and the most harmful event was a collision with a tree or utility pole. The cases were then reduced to those that contained known quantities for the variables required in the logistic regression model, including; travel speed, helmet use, motorcyclist age, speed limit (compared with travel speed to ascertain if the motorcyclist was speeding), motorcycle model year, lighting condition, location relative to an interchange, and roadway profile. The reader is referred to Bambach et al. (6) for details of the analysis.

From the FARS database it was determined that for the years from 2000 to 2009 (inclusive), there were 11,681 fatal fixed-object motorcycle crashes; 1,964 fatal single-vehicle rural motorcycle collisions with trees or poles; and 782 of these 1,964 cases contained known values for the required model variables. Table 2 presents the main notable results of the fatality risk analyses which were the reductions in the fatality risk resulting from the various road safety measures investigated, compared with the original fatality risk (%). The reductions were calculated for each of the 782 cases, and group means are also presented.

Fatality risk profiles are presented for the various road safety measures investigated in Figure 7. In this figure, the fatality risk determined from the logistic regression model for each case is plotted against the travel speed. For the cases considering the fatality risk for a reduced travel speed (Figures 1c and 1e), the reduced travel speed is plotted. The numbers of cases falling within each decile of fatality risk are presented in Figure 8, for the various road safety measures investigated.

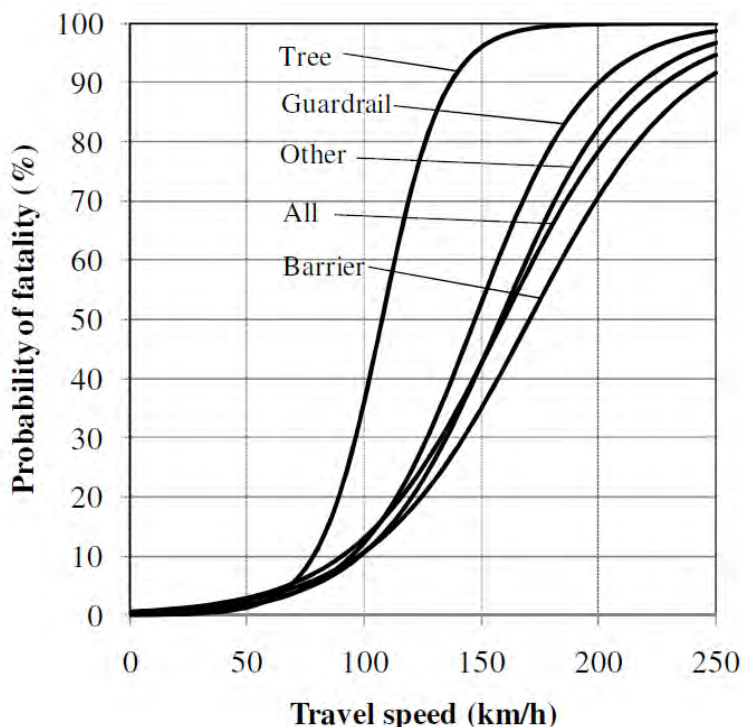
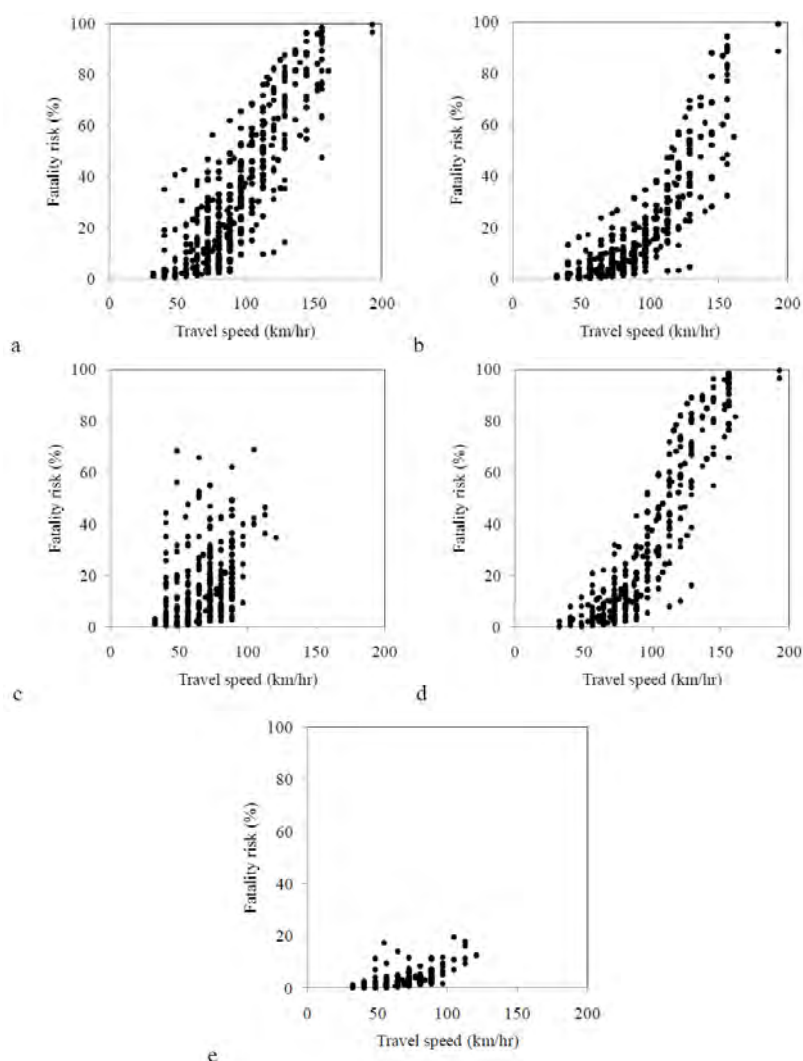

**FIGURE 6** Probability of fatality versus travel speed comparing type of fixed object (5).



**TABLE 2 Reduction of Fatality Risk Results of all Fatal Motorcycle Rural Roadway Departure Collisions with Trees and Utility Poles in the United States, 2000 to 2009 Inclusive ( $n = 782$ ) (6)**

Treatment	Reduction of fatality risk (%)			
	Mean	Standard deviation	Mean when travel speed <100km/hr	Mean when travel speed >100km/hr
a. Barrier	15.0	9.6	11.1	21.8
b. Speed not exceeding speed limit	29.9	16.3	10.8	44.1
c. Helmet use	10.6	6.7	11.9	6.1
d. All of a,b,c	31.7	26.2	16.1	58.7
e. 10% reduced speed limit	21.1	25.4	6.3	46.7
f. 20% reduced speed limit	23.3	26.4	8.0	49.9
g. 30% reduced speed limit	25.0	27.2	9.2	52.4



**FIGURE 7 Motorcyclist fatality risk profiles, conditional on a rural roadway departure into a tree or utility pole, for road safety measures: (a) none, (b) install barrier, (c) not exceeding the speed limit, (d) helmet use, and (e) all measures (b, c, and d).**

Table 2 and Figures 7 and 8 all indicate that to significantly reduce single-vehicle motorcycle fatalities involving trees and poles, road authorities can install a barrier and ensure motorcyclists wear a helmet and travel at the posted speed limit. The fatality risk essentially drops to a very small level of risk. Just ensuring that motorcyclists travel at the posted speed limit reduces the risk by around 30%.

## CONCLUSIONS

The following conclusions were reached from the retrospective study described above, of motorcyclists that were fatally injured following a collision with a roadside barrier during the period 2001 to 2006 in Australia and New Zealand (1–6, 11–14).

It was found in Garcia et al. (11) that rider behavior plays a significant role in motorcyclist fatalities into roadside barriers in Australia and New Zealand. Alcohol, drugs, or speed played a role in two out of every three fatal barrier crashes. Further, crashes appeared to occur predominantly on recreational rides. It was also noted that a high proportion of the motorcyclists were on recreational rides in areas that provide challenging riding conditions when they collided with a barrier. An association between riding a sports motorcycle and receiving thorax injuries was established (1).

A similar situation exists in the United States in that rider behavior in terms of excessive speed and not wearing helmets also appears to play a significant role in motorcyclist fatalities. Table 2 and Figures 7 and 8 indicate that enforcing helmets and travel speeds within speed limits, coupled with installation of a roadside barrier where tree and pole impacts are a risk, eliminates fatalities.

The majority of motorcycle into barrier crashes resulted from collisions with steel W-beam barriers in Australian and New Zealand data. Both sliding and upright crash postures were approximately equally represented and mean pre-crash speeds and impact angles were found to

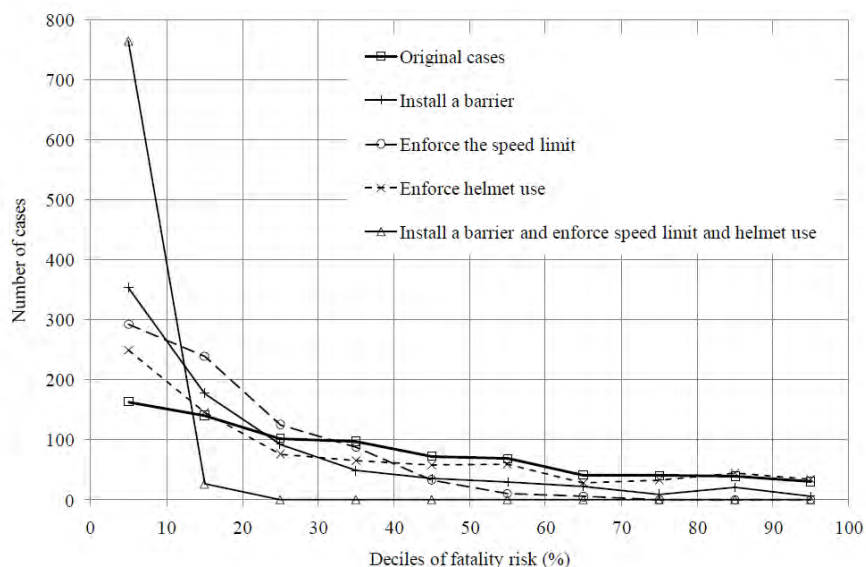

**FIGURE 8** Number of cases falling within each decile of fatality risk.

be 100.8 km/h and 15.4° respectively. The thorax region was found to have the highest incidence of injury and the highest incidence of maximum injury in fatal motorcycle–barrier crashes, followed by the head region. As existing motorcycle–barrier crash testing protocols do not specify a thorax injury criterion, there appears to be a need to determine such criteria. Similarly around a quarter of the crashes involved an upright crash posture with the rider subsequently sliding and tumbling along the top of the barrier. An additional test should be developed, possibly similar to the DEKRA test proposed by Berg et al. (5), which requires the rider to impact the barrier up right and then slide along the top of the barrier. The Berg et al. paper further proposes that a rub rail along the bottom of the barrier and a smooth surface along its top would reduce motorcycle into barrier injuries.

## ACKNOWLEDGMENTS

This study was funded by the New South Wales Road and Traffic Authority (RTA), Motor Accidents Authority of New South Wales (MAA), The Road Safety Council WA (RSC), New Zealand Transport Agency (NZ TA), and the Australian Automobile Association (AAA). The support of the following people was greatly appreciated: Soames Job (RTA), Steve Levett (formerly of the RTA), David Pratt (RTA), Wal Smart (RTA), Dimitra Vlahomitros (formerly of the MAA), Jan Karpinski (WA Main Roads), Brian Kidd (WA Main Roads), Iain Cameron and Jon Gibson (Office of Road Safety ORS, WA), Fabian Marsh (formerly of NZ Transport Agency), James Cameron (AAA), Craig Newland (AAA), and Rob Smith and Mario Attard (Department of Civil and Environmental Engineering, UNSW). While representatives from the sponsors were not involved in the design, collection, analysis, and neither the presentation of the data nor the writing of this report, they were part of a Scientific Advisory Committee reviewing project progress and discussing results.

The authors thank the Victorian Institute of Forensic Medicine as the source organization of the National Coroners Information System from which crash data was extracted for the statistical analysis. The authors would especially like to thank Marde Hoy and Jo Cotsonis for training and assistance with accessing the NCIS database. All the state coroners are also acknowledged for granting permission to view the case files. The following people were particularly helpful: Michell Heidtman (ACT), Alex Tilley (NSW), Victoria Hall (NT), Leanne Field (Queensland), Annemarie Van Putten (SA), Jenny Scott (Tasmania), Emma Flatman (Victoria), and Gary Cooper (WA).

## REFERENCES

1. Bambach, M., R. H. Grzebieta, and A. S. McIntosh. Motorcycle Crashes into Roadside Barriers Stage 2: Crash Mechanics and Injury Causation. IRMRC Research Report, 2010. Available at [http://www.tars.unsw.edu.au/downloads/Stage2\\_report.pdf](http://www.tars.unsw.edu.au/downloads/Stage2_report.pdf).
2. Bambach, M. R., R. H. Grzebieta, and A. S. McIntosh. Crash Characteristics of Motorcyclists Impacting Road Side Barriers. *Proc., Australasian Road Safety Research, Policing and Education Conference*, Canberra, Australia, 2010.
3. Bambach, M., R. H. Grzebieta, and A. McIntosh. Injury Typology of Fatal Motorcycle Collisions with Roadside Barriers in Australia and New Zealand. *Accident Analysis and Prevention*, 2011.

4. Bambach, M. R., R. H. Grzebieta, J. Olivier, and A. S. McIntosh. Motorcycle Crashes into Roadside Barriers Stage 3: Survivability Analysis. IRMRC Research Report, 2011.
5. Bambach M. R., R. H. Grzebieta, J. Olivier, and A.S. McIntosh. Fatality Risk for Motorcyclists in Fixed Object Collisions. *Journal of Transportation Safety and Security*, Vol. 3, No. 3, 2011, pp. 222–235.
6. Bambach, M., and R. Grzebieta. Fatality Risk Mitigation for Rural Motorcycle Collisions with Trees and Utility Poles. Presented at 91st Annual Meeting of the Transportation Research Board, Washington, D.C., 2012.
7. Berg, F. A., P. Rucker, M. Gartner, J. Konig, R. Grzebieta, and R. Zou. Motorcycle Impacts into Roadside Barriers: Real-World Accident Studies, Crash Tests and Simulations Carried Out in Germany and Australia. *Proc., 19th International Conference on the ESV*, Washington, D.C., 2005.
8. EuroRap. Barriers to Change: Designing Safe Roads for Motorcyclists. Publication Number 01/08. European Road Assessment Program, Basingstoke Hampshire, United Kingdom, 2008.
9. Gabler, C. The Risk of Fatality in Motorcycle Crashes with Roadside Barriers. *Proc., 20th International Technical Conference on ESV*, 2007.
10. Garcia, J., D. Garcia, A. Molinero, and J. M. Perandones. Improving Motorcyclists' Safety in Spain by Enhanced Crash Test Procedures and Implementation Guidelines. *Proc., 21st International Technical Conference on ESV*, 2009.
11. Grzebieta, R. H., H. Jama, R. Friswell, M. Bambach, A. S. McIntosh, and J. Favand. Motorcycle Crashes into Roadside Barriers Stage 1: Crash Characteristics and Causal Factors. IRMRC Research Report, 2010. Available at [http://www.tars.unsw.edu.au/downloads/Stage1\\_report.pdf](http://www.tars.unsw.edu.au/downloads/Stage1_report.pdf).
12. Grzebieta, R. H., M. Bambach, A. S. McIntosh, R. Friswell, and H. Jama. Fatal Motorcycle-into-Road-Safety-Barrier Crashes. *Proc., Australasian Road Safety Research, Policing and Education Conference*, Perth, Australia, 2011.
13. Grzebieta R.H., Jama H., McIntosh A., Friswell R., Favand J., Attard M., Smith R., (2009) Overview of Motorcycle Crash Fatalities Involving Road Safety Barriers, *Journal of the Australasian College of Road Safety*, November, Vol. 20 No. 4, pp. 42 – 52. (also published in *Proceedings Road Safety Research, Policing and Education Conference*, Sydney, Australia, November 2009).
14. Jama, H. H., R. H. Grzebieta, R. Friswell, and A. S. McIntosh. Characteristics of Fatal Motorcycle Crashes into Roadside Safety Barriers in Australia and New Zealand. *Accident Analysis and Prevention*, Vol. 43, No. 3, 2011.
15. Ouellet, J. V. Environmental Hazards in Motorcycle Accidents. *Proc., American Society for Automotive Medicine 26th Annual Conference*, Ottawa, 1982, pp.117–129.
16. Peldschus, S., E. Schuller, J. Koenig, M. Gaertner, D. G. Ruiz, and A. Mansilla. Technical Basis for the Development of a Test Standard for Impacts of Powered Two-Wheelers on Roadside Barriers. *Proc., 20th International Technical Conference on ESV*, 2007.
17. prEN 1317-8. Road Restraint Systems—Part 8: Motorcycle Road Restraint Systems Which Reduce the Impact Severity of Motorcyclist Collisions with Safety Barriers. Revised draft, 2010. prEN 1317-8 – WI 00226127.
18. Ruiz, D. G., B. P. Magallon, S. Peldschus, E. Schuller, A. M. Gallo, and S. Bidal. Overview on the Development of a Test Standard for the Evaluation of Motorcyclists' Impacts on Road Infrastructure Elements. *International Journal of Crashworthiness*, Vol. 15, No. 1, 2010, pp. 1–17.
19. Selby, T. Motorcyclists and Wire Rope Barriers. Transit New Zealand Positioning Paper, 2006.
20. UNE 135900-1,2. Spanish Standard: Performance Evaluation of Motorcyclist Protection Systems in Safety Barriers and Bridge Parapets, Parts 1 and 2, 2008.

## SESSION 3: BEST PRACTICES

## Best Practices and Strategies to Reduce Fatal or Serious Injury Crashes into Obstacles and Road Equipment

### *Swedish Experience*

ÅKE LÖFQVIST

*Swedish Transport Administration*

The traffic safety development is constantly going in the right direction. The last 10 years has seen almost 40% reduction of fatalities despite ~9% higher traffic flow (Figure 1). We believe that we can meet the current target, of not more than 220 fatalities in 2020.

The European Union has recently set a new goal to reduce the number of fatalities in 2020 to half of those recorded in 2010. For Sweden, this means 133 fatalities, which corresponds to the very low figure of 1.4 fatalities per 100,000 inhabitants. We have calculated that, with a certain amount of effort, it is possible to achieve this goal.

The proportion between fatal single or run-off accidents and head-on crashes were 10 years ago 47/53. Five years later it had changed to 60/40, mainly due to the large amount of 2+1-roads with a median barrier that prevents head-on crashes.

The first steps to introduce safer roads in Sweden were taken during the 1970s with significant influence mainly from Germany and the United States (Figure 2). The inner or back slopes became 1:3/1:2 and clear zones with a width of about 4 m at 90 km/h were introduced.

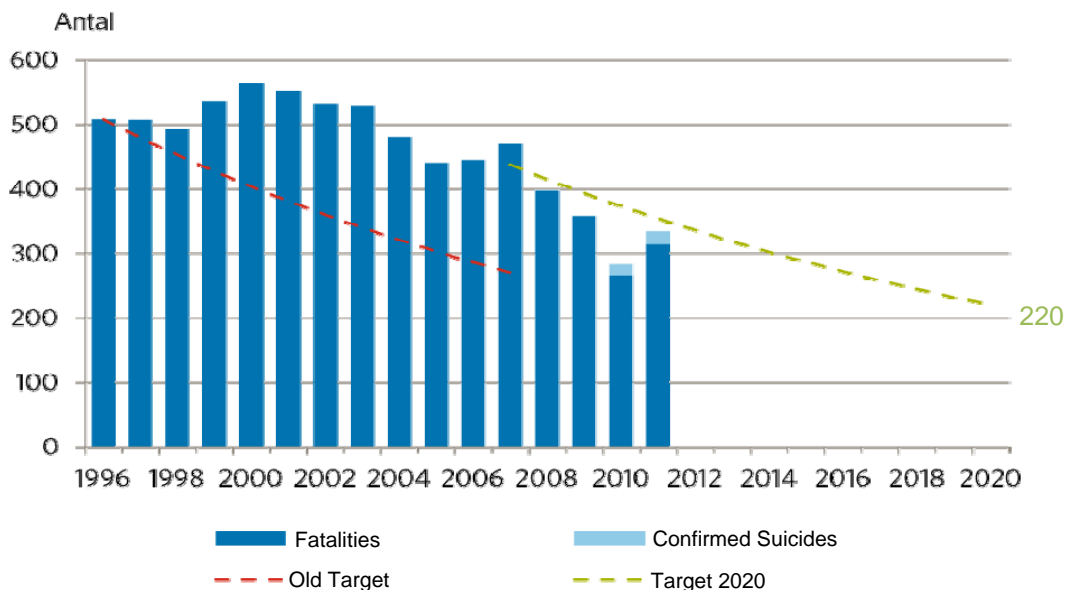

**FIGURE 1 Swedish road crash statistics.**

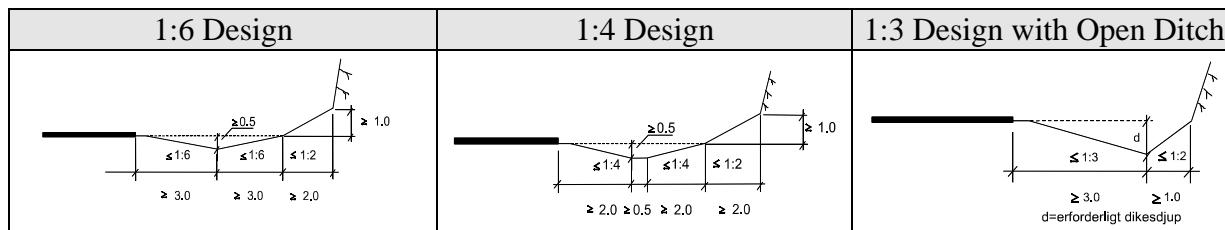

**FIGURE 2** Verge designs.

The design guideline from 1994 was a breakthrough for modern roadside area design with clear zone requirements of 9 m at 90 km/h for example. A concept from the United States with smooth slopes was also implemented with three alternative design levels depending on traffic volume and speed limit. Figure 2 is shown with rock cut.

The clear zone was not allowed to contain any dangerous obstacles such as gantries, sign or lamp posts, trees >0.1 m, etc. If so, a guardrail had to be installed. Most common were the W-beam on  $\Sigma$ -shaped posts.

## EXISTING AND UPCOMING DESIGN GUIDELINES

The slightly revised guideline from 2004—VGU (*Road and Street Design Manual*, available at <http://www.trafikverket.se/vgu>), including later supplements—points out that the 1:6 design does not have any safety advantages over the 1:4 designs. Instead, secondary accidents (e.g., cars leaving the roadside area uncontrolled, crossing the median and colliding with oncoming vehicles, or roll-over accidents) were experienced (Figure 3).

In the cases of obstacles in the clear zone or poor roadside areas, a standard guardrail is recommended. The length is determined by the encroachment angle depending on design speed, e.g., 110 km/h and  $6^\circ$ . The length might be shorter due to flared installation.

The upcoming guidelines, expected later this year, will improve the roadside safety design further. Improvements include lower embankment height, more distinct advice on how to use high-capacity guardrails, and, finally, showing the standard solution with flared guardrail anchorages (Figure 4).

The new guidelines also handle the speed limit review in Sweden which aims to abandon the 50-, 70-, and 90-km/h limits, preferring 30-, 40-, 60-, 80-, 100-, 110-, and 120-km/h limits.

## EXPERIENCES FROM ACCIDENTS WITH ROAD EQUIPMENT

The Swedish Road Administration (now the Swedish Transport Administration) has conducted in-depth studies for every fatal road traffic accident since 1997 (Figure 5).



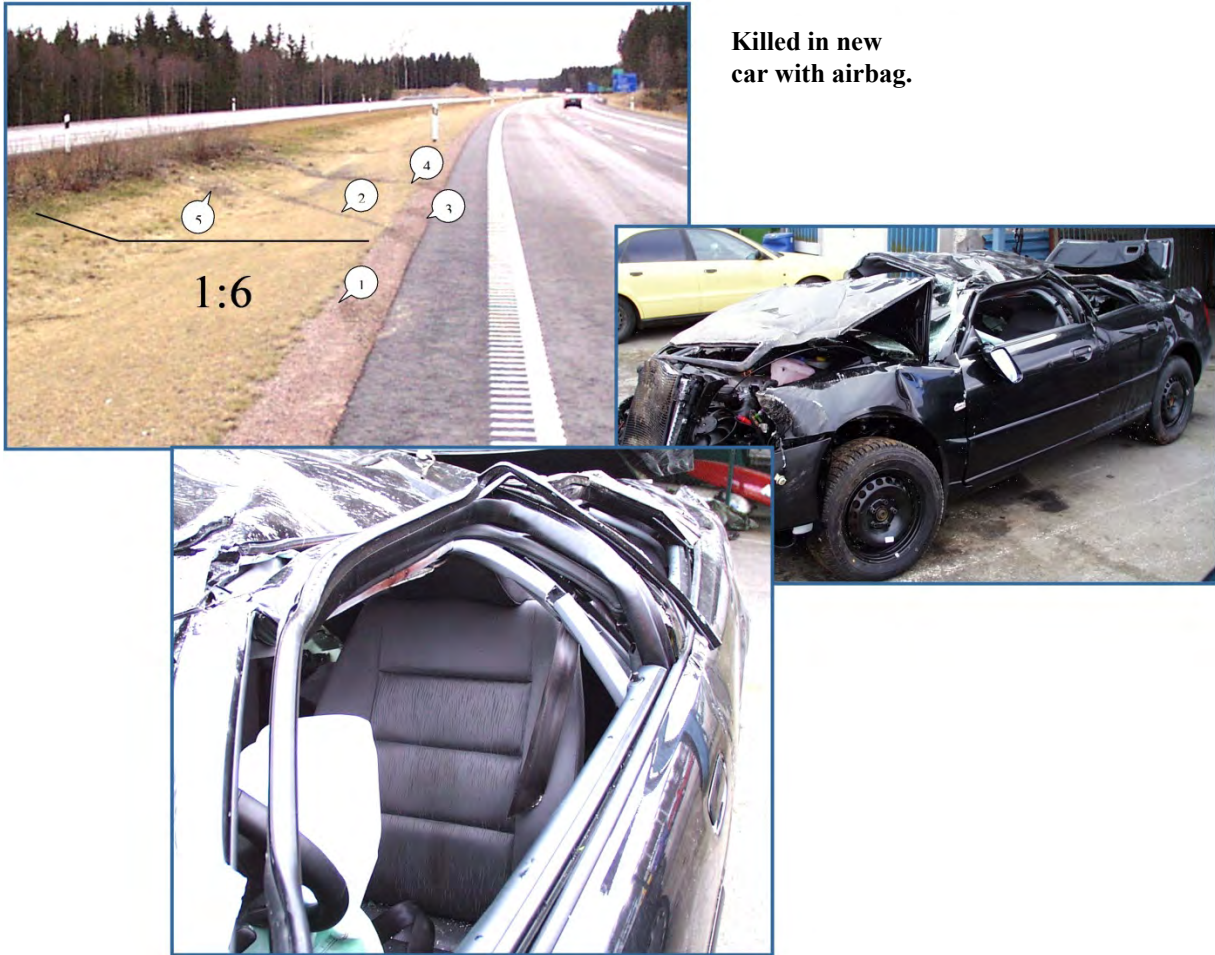

**FIGURE 3 Fatal crash on a 1:6 median.**



**FIGURE 4 Current barrier installation details.**





**FIGURE 5 Fatal crash investigation.**

Concerning accidents with road equipment, where guardrails are most common, four to five typical common factors are seen:

- Very old equipment, e.g., guardrail from the 1960s is not working properly;
- Too-short installation in which the vehicle goes behind the guardrail—the “open window” effect;
- Ramped-down terminal creates an uncontrolled ramp effect;
- Energy-absorbing terminal is not hit in a proper way; and
- Vehicle highly exceeds the design speed.

However, it is unsafe to draw conclusions with statistical accuracy because the distribution of accident types is extensive. It is most important to replace old equipment, e.g., too-low height, dangerous terminals, and insufficient anchoring.

## HOW TO HANDLE GUARDRAIL TERMINALS

When the German W-beam (A-profile) was introduced in Sweden in the early 1970s, the anchorage was 12 m, ramped down, flared about 0.4 m from the road.

The guidelines from 1994 recommended energy-absorbing terminals as the safest but showed also the possibility to flare the guardrail wider with the purpose to “close the window” (recommended flare rate 1:20 for 110 km/h). The solution became however not widely used.

In the late 1990s, the energy-absorbing terminals were introduced in Sweden, mainly the American design with wood posts (Figure 6). Thousands of them were installed, many on existing roads with 1:3 inner slopes. After some years, we became aware of accidents on those terminals, some of them fatal. There were also accidents with better installation locations.



**FIGURE 6 Energy-absorbing terminal.**

The next step was to use the flared guardrail following the inner slope and anchored outside the ditch in the backslope. At embankments the ramped-down anchor was placed 3 to 5 m outside the road. To be more certain about the functionality we had some crash tests done with good results (Figure 7).

The experiences so far are good; the guardrail has behaved well unless it was overloaded by a too-heavy vehicle.

The standard solution is a flared guardrail anchored in the backslope or ramped down at least 5 m from the road, with at least  $\frac{1}{2}$  clear zone width proposed.

Energy-absorbing terminals might be used due to lack of space or in some urban areas. Ramped-down terminals might be used at low speed or low traffic volume.



**FIGURE 7 Full-scale testing of the proposed terminal design.**

## SESSION 3: BEST PRACTICES

## Best Practices and Strategies to Reduce Fatal or Serious Injury Crashes into Trees and Posts

### *German Experience*

**FRANK BRANDT**  
*Volkman & Rossbach*

In Germany, along thousands of kilometers of rural roads, are trees standing next to the carriageway, for example 2.900 km along Deutsche Alleenstraße, from north to south Germany (Figure 1).

Nearly 20% (651 in 2010) of all fatal accidents on German roads result from a crash with a tree. The chance of road users dying after a collision with a tree is around 2.3 times greater than the chance of dying in an average traffic accident on a road outside of a built-up area (excluding freeways). Trees beside the road are black spots, causing a high danger for road users. If it is necessary to remove them, they must be replaced in places far away from the traffic. Trees that cannot be removed due to protection by law (objects of cultural value) must be protected with guardrails.

The solution according to the German Guideline RPS 2009 is to install vehicle restraint systems, evaluated to European Normative (EN) 1317, Containment Level N2, and H1

There are a number of new products that have been designed to meet a range of different needs. For instance, there is a steel system that is stiffened near a tree so that the deflections are manageable. This system is shown in Figure 2 and is used to protect single obstacles like trees or poles. In combination with other standard guardrails it is also suitable for tree-lined roads.

The second product is a post and rail system where the posts are placed at various spacings, allowing for different containment levels (Table 1).

#### 3.3 Outer edge of carriageway:

- (1) The hazard potential of danger spots at the outer edge of the carriageway is classified according to four hazard levels:
- Hazard level 1: Areas requiring protection with special risks for third parties (e.g., potentially explosive chemical plants, heavily used stopping areas, adjacent sections of high-speed railways with permitted speeds >160 km/h, buildings in danger of collapse);
  - Hazard level 2: Areas requiring protection with risks for third parties (e.g., adjacent, heavily used footpaths and cycle paths, adjacent rail lines with more than 30 trains/24 h, adjacent roads with ADT >500 vehicles/24 h);
  - Hazard level 3: Obstacles with special risks for vehicle passengers (e.g., non-deformable, extensive obstacles vertical to the direction of the traffic, non-deformable, isolated individual obstacles, noise barriers);
  - Hazard level 4: Obstacles with risks for vehicle passengers [e.g., isolated obstacles which are deformable but do not buckle or shear off, intersecting ditches, ascending slopes (incline >1:3), descending slopes (height >3 m and incline >1:3), stretch of water with a depth >1 m, white water].

**FIGURE 1 Hazard levels as described in German Guidelines.**



**FIGURE 2 Stiffened barrier near a tree.**

**TABLE 1 Containment Level for Different Post Spacings**

Post distance	6.00 m	4.00 m	2.00 m	1.33 m
Containment level	N2	N2 N2-H1		N2-H1
Working width	W5	W4 W3-W4		W2-W3
Impact severity	A	A A A		
Number of posts	0.66 posts/4 m	1 post/4 m	2 posts/4 m	3 posts/4 m

### FATAL ACCIDENTS WITH INSUFFICIENT PROTECTED POSTS OR GANTRY PLINTHS

The solution according to the German Guideline RPS 2009 is to install a vehicle restraint systems evaluated to EN 1317, Containment Level H2, and H4b.

A third product is a guardrail system with rails at multiple heights (Figures 2 and 3). This product fulfills requirement classes H2 and H4b of DIN EN 1317-2 and combines high restraint capacity with very low system deflection. The construction offers key advantages compared to classic systems when the highest possible level of safety is required, e.g., before truck break-throughs. The hazard potential is also significantly decreased for vehicle occupants through the excellent impact characteristics (accident severity level A; ASI = 1.0). The H2 device had a W4 working width classification and the H4b system has a W8 working width classification.



**FIGURE 3 Higher barrier to protect gantries and bridge piers.**



## SESSION 3: BEST PRACTICES

## Best Practices and Strategies to Reduce Fatal or Serious Injury Crashes into Posts and Luminaire Supports

### *U.S. and International Experiences*

**ARTHUR M. DINITZ**  
*Transpo Industries, Inc.*

Countries throughout the world are seeking ways to increase safety and comply with traffic laws on roads and highways, reducing the number of fatal and serious injury crashes into posts and luminaire supports.

### **BREAKAWAYS**

The history of breakaways systems for signs and light posts goes back 50 years in the United States. In the 1960s, roadside hazards were identified as a major cause of fatalities and serious injuries. It became evident that if the obstacle could not be removed, it should be made to breakaway or, if it could not be made breakaway, it should be protected using redirective devices.

Sign supports are often located immediately adjacent to roadways and are subject to impact by errant vehicles and must yield or breakaway if struck. Since the 1970s in the United States, omnidirectional breakaway couplings for light pole and signpost support have become the standard for many states and thousands of lives have been saved.

New Zealand, Australia, Canada, and others have begun to use omnidirectional breakaways and there is increasing global interest in this technology. Eastern Europe and the Netherlands are currently examining the use of breakaways for their roadways.

In Israel, highway safety support structures have been used for more than 20 years. Hazard removal or treatment using breakaway systems are preferred over the more-expensive and still more-hazardous installation of guardrails. Dozens, if not hundreds, of accidents have been witnessed with no fatalities or serious bodily harm injuries reported on light poles using omnidirectional breakaways.

Until now, the use of energy-absorbing posts in Europe has been the only form of yield supports used. However, as seen in many of the crash tests in the United States, these energy-absorbing posts at high speeds can entrap the vehicle causing yaw which overturns the vehicle and results in serious bodily harm.

### **FORGIVING ROADWAYS**

Roadways are now designed with a forgiving concept. Still, approximately 34,000 fatalities occurred in the United States and approximately 1.3 million fatalities occurred worldwide in 2010. Seventy percent of vehicle fatalities involve cars leaving the roadway and either overturning or colliding with fixed objects. Breakaways for ground-mounted signs and luminaries can significantly decrease the severity of these accidents and resulting fatalities ([Figure 1](#)).

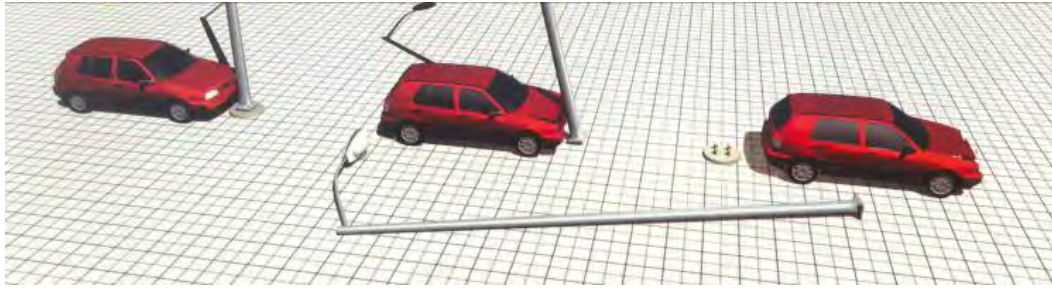

**FIGURE 1 Breakaway pole collapse mechanism.**

*NCHRP Report 350: Recommended Procedures for the Safety Performance Evaluation of Highway Features* and AASHTO's *Manual for Assessing Safety Hardware* present procedures for conducting crash tests and in-service evaluation of roadside safety devices including breakaways or yield supports (signs and luminaries). In AASHTO's *Standard Specifications for Structural Supports for Highway Signs, Luminaires, and Traffic Signals*, Section 12 addresses the structural, breakaway, and durability requirements for structures required to yield, fracture, or separate when struck by an errant vehicle. Breakaways need to be designed to meet both structural and dynamic performance requirements.

### **Dynamic Requirements**

1. The longitudinal component of occupant velocity at impact due to a vehicle striking a breakaway support shall not exceed 5 m/s (16.4 ft/s).
2. Substantial remains of breakaway supports shall not project more than 100 mm (4 in.). The specified limit on the maximum stub height lessens the possibility of snagging the undercarriage of a vehicle.

### **Structural Performance Requirements, Sign Post Spacing, and Pole Size**

1. Breakaway supports shall be designed to carry loads using the appropriate allowable stresses for the material used.
2. Wind load design up to 150 mph (240 km/h) basic wind speed.
3. Multiple post spacing for signs: 7 ft (2.1 m) between.

### **Breakaways Are Impact Tested Using the Critical Angle of Impact**

1. Slip base: 0 to 25 degrees.
2. Frangible bases: 0 to 90 degrees.
3. Frangible couplings: 0 to 90 degrees.

### **Choices on Breakaways: Slip Base and Omnidirectional Breakaways**

1. Slip base:
  - Sign slip bases work where the vehicle strikes the support in the direction of the traffic (notches). The upper post separates from the imbedded portion.

2. Omnidirectional breakaways (and frangible sign posts, primarily used on small sign posts). These breakaways are designed to break away when a vehicle strikes at any angle of impact.
3. Frangible bases: For small sign supports:
  - Tear away,
  - Stripped bolt, and
  - Omnidirectional breakaway (frangible) coupling.
4. Frangible couplings: For large sign supports. (The primary components of the system are high-strength couplings.)

Designed for poles located within roadside clear zones and other locations vulnerable to vehicular impacts, omnidirectional breakaway couplings have become a standard for many states in the United States. (Omnidirectional means the system breaks away with consistent predictable behavior regardless of the vehicle's angle of impact and is designed to break away quickly and cleanly upon impact, thus saving lives and reducing property damage.) These couplings are strong enough to hold up 16-m high pole weighing 450 kg and withstand 240 km/h winds, but will breakaway consistently as shown in standard crash testing for breakaway systems.

## SAVING LIVES

One of the key issues to ensuring greater safety in transport is to identify and treat hazardous locations and objects. By using breakaway supports that are designed to break away quickly and cleanly upon impact, with consistent, predictable behavior, regardless of the vehicle's angle of impact (omnidirectional), will result in reduced property damage and lives saved.

## RESOURCES

- AASHTO. *Standard Specifications for Structural Supports for Highway Signs, Luminaires, and Traffic Signals* (5th edition), 2009.
- Ross, H. E., Jr., D. L. Sicking, R.A. Zimmer, and J. D. Michie. *NCHRP Report 350: Recommended Procedures for the Safety Performance Evaluation of Highway Features*. TRB, National Research Council, Washington, D.C., 1993.



## SESSION 3: BEST PRACTICES

**EN 12767*****Passive Safety of Support Structures for Road Equipment*****CAROLIEN WILLEMS***Safety Product Belgium*

The poles for public lighting must basically correspond to the European Normative (EN) 40. Poles for signalization apply to EN 12899, regarding resistance. These standards define the technical properties of poles regarding dimensions, installation and other characteristics yet not dealing with a pole as a passive element of traffic in respect to the safety.

In EN 12767 the impact for passengers and the exit speed is determined: how much energy of the crash is absorbed by the infrastructure and how is the speed lowered to minimize the risk after the first crash.

**INTRODUCTION**

The standard EN 12767, Passive Safety of Support Structures for Road Equipment, evaluates two parameters which categorize the support structures of the road equipment which are category of energy absorption in case of the car crash and the level of safety for the persons being in the car, all this at exactly defined conditions regarding the equipment used in the test as well as the procedure of testing.

**ENERGY ABSORPTION**

The seriousness of the occupants' injuries is the consequence of the impact in case of a crash into support structures for road equipment. If we think about safety, such support structures could be done in a way that they disintegrate or bend in a case of a car crash. The cited European standard enables common base for the testing of a car crash onto support structures of the road equipment. European standard foresees three categories of passive safety for support structures:

- High energy absorbing (HE),
- Low energy absorbing (LE), and
- Non-energy absorbing (NE).

The support structures that absorb the energy of a hit are slowing down the vehicle significantly and lower the risk for a secondary hit of the vehicle into the objects in surrounding, trees, pedestrians, or other participants in the traffic. The support structures that do not absorb the energy of a hit allow the vehicle to proceed with just a little lower speed further on. Such support structures enable lower primary risk for the occupants but remains a big risk for a secondary collision into an obstacle in vicinity.

The standard determines the category of energy absorption in relation to three different initial speeds and their related exit speeds with their maximum and minimum limits. Support structures for which exists no request for efficiency regarding the passive safety are marked with a category 0.

The support structures that do not deform in case of a vehicle impact or they deform just minimally, that is, all those where the complete energy of collision overtakes the vehicle and the occupants, are not classified in the passive safety support structures at all. Such support structure is for example a rigid lighting column. The consequences of a collision could be immense (Figure 1).

## LEVELS OF OCCUPANT SAFETY

There are four levels of occupants' safety specified. Level 1, 2, and 3, in this order, present an increase of occupants' safety which means lowering the effect of the impact onto the support structure. For these levels of safety a test has to be performed at

- 35 km/h to verify the sufficient functionality of support structures at low speed and
- Speed classes of impact speed (50, 70, and 100 km/h) as given in a Table 1.

Level 4 includes non-harmful support structures that are assumed to cause only minor damage. A simplified test at a certain speed class should be done and the difference between impact speed and exit speed may not be more than 3 km/h (*I*).

All tests must be done with lightweight cars for the reason that the level of impact severity in respect to the occupants' safety in such type of cars is ensured. The test vehicle must be a standard passenger car with inertial mass of  $825 \text{ kg} \pm 40 \text{ kg}$ , with maximum allowed ballast 100 kg, test dummy of  $78 \text{ kg} \pm 5 \text{ kg}$ , and other characteristics described in the article 6.2.1 of standard (*I*).



**FIGURE 1** Crash into a rigid pole.

**TABLE 1 Test Speed Characteristics**

Impact speed, $v_I$ km/h	50	70	100
Energy absorption category	Exit speed, $v_e$ km/h		
HE (high)	$v_e = 0$	$0 \leq v_e \leq 5$	$0 \leq v_e \leq 50$
LE (low)	$0 < v_e \leq 5$	$5 < v_e \leq 30$	$50 < v_e \leq 70$
NE (none)	$5 < v_e \leq 50$	$30 < v_e \leq 70$	$70 < v_e \leq 100$

Speed after impact is reduced.



To determine the level of occupants' safety two parameters are used: ASI (Acceleration Severity Index) and THIV (Theoretical Head Impact Velocity), both in regard to the class of impact speed and the category of energy absorption (Figure 2 and Table 2).

Different demands and evaluations are taken into account not only for occupants' safety to determine the type of support structures for road equipment whereas following parameters are taken into consideration:

- Expected risk of accident's damage or harm and possible calculation of cost and benefit;
- Type of the road and its geometry;
- Characteristic speed of a vehicle on a certain location;
- Presence of other objects, constructions, trees, or pedestrians; and
- Presence of different systems for lowering the speed.

In such way the road authorities on different levels of administration (state, provincial, regional, and municipal) specify the request for a certain level of passive safety of support structures. These decisions could be different in different regions or states and they depend very much on a consciousness of decision takers, that is, how much are they aware about the need for passive safety on the roads.

Based on the tests successfully done, the producer obtains the corresponding certificate in which is exactly stated the product, its category, and the level of occupant safety.

## APPLICATIONS IN DIFFERENT COUNTRIES IN EUROPE

Having in mind the increase of passive safety of the roads, the Flemish Road Administration decided to install the HE poles

- On all roads where the allowed speed is over 50 km/h and where there are no guardrails in front of the lighting poles;
- On all roads where the allowed speed is under 50 km/h but the lighting columns must be closer than 2 m from the edge of the pavement and there are no guardrails in front of the columns;
- On all roundabouts where the speed is not limited to 30 km/h; and

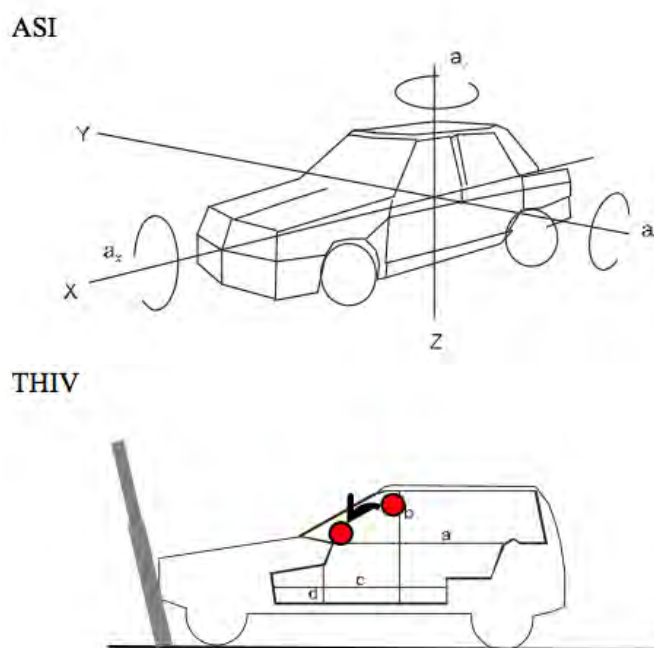

FIGURE 2 ASI and THIV.

TABLE 2 Occupant Protection Levels

Energy Absorption Categories	Occupant Safety Level	Speeds			
		Mandatory Low-Speed Impact Test, 35 km/h		Speed Class Impact Tests, 50, 70, and 100 km/h	
		Maximum Values		Maximum Values	
		ASI	THIV km/h	ASI	THIV km/h
HE	3	1.0	27	1.0	27
HE	2	1.0	27	1.2	33
HE	1	1.0	27	1.4	44
LE	3	1.0	27	1.0	27
LE	2	1.0	27	1.2	33
LE	1	1.0	27	1.4	44
NE	3	0.6	11	0.6	11
NE	2	1.0	27	1.0	27
NE	1	1.0	27	1.2	33

- On places where there exists a high possibility for a vehicle to crash onto the pole, such as roads leading to roundabouts, roads in between roundabouts, curves, crossing with sharp angles, etc.

Lately, the installation of HE poles became interesting also on the entrances and exits of the highways because there is no need for guardrails in front of the columns if safe columns are used.

In Holland the prescription is

- If there is an obstacle-free zone of 40 m wide by 50 m long they install 100NE3 poles and
- If the zone is smaller the national road authorities install 100HE3 poles (3).

In Finland, HE poles are installed in urban areas to avoid the risk of having a secondary accident: getting the speed out of the car reduces the risk towards other road users. Slip base poles are no longer used (4).

Further steps (beside other measures for higher safety on the roads) encouraging the authorities and investors to prescribe and use passive safe infrastructure elements was done by a European Transport Safety Council document about European road safety, mentioning also so-called “forgiving roadside” (2).

## NEW ENERGY-ABSORBING POLE CONCEPT

A new energy-absorbing pole was constructed of steel plates making a cross section with nine angles. The plates are not welded together to form the final shape but are joined with rivets. Such construction ensures that the column is strong enough for the functional use. It can support the lamp or other equipment but in case of a car’s impact it starts flattening step by step so that it turns the form from an almost-round shape into a ribbon, which means that the deformation of a column reduces the impact force of a vehicle. This attribute allows for the energy-absorbing principle to occur, regardless of the height of the column that might be hit. So, even in a case in which the car jumps into the pole a meter or two above the ground level, the pole will react in the same way as being hit at the ground level. Poles of this type have already been tested according to the 2008 standard EN 12767 and have successfully passed the test.

## REFERENCES

1. European Standard EN 12767: Passive Safety of Support Structures for Road Equipment—Requirements, Classification and Test Methods. Comité Européen de Normalisation, Brussels, Belgium, 2007.
2. Avenoso, A., and E. Townsend. European Transport Safety Council. Future Road Safety in the EU at Stake? ETSC Response to the EC communication Towards a European Road Safety Area: Policy Orientations on Road Safety 2011–2020, European Transport Safety Council, 2010.
3. Componentspecificatie openbare verlichting, 30 mei 2011, versie 2.5.
4. Milne, D. The Finnish Experience with Passively Safe Lighting Columns, Designing Safer Roadside.

SESSION 4

**New Road Safety Products**





## SESSION 4: NEW ROAD SAFETY PRODUCTS

**Development of a Redirective Crash Cushion to EN 1317-3****PASQUALE IMPERO****MAURO CORSANICI***Industry AMS srl, Via Saggese***LUIGI GRASSIA***Second University of Naples*

The problems involved in the development of a crash cushion can be schematized as the problem to stop a certain mass moving at an initial velocity,  $V_0$ , in a certain space,  $X_0$ .

The European Normative (EN) 1317 defines a limit for the maximum deceleration of the vehicle during the impact of a crash cushion through the definition of the Accident Severity Index (ASI) parameter.

During impact, the force required to deform the crash cushion affects cushion the level of deceleration of the vehicle, simply because the inertial force,  $F = m a$ , of the vehicle (where  $m$  is the mass of the vehicle and  $a$  is the deceleration) equals at each time the force,  $F$ , required to deform the crash cushion. Generally crash cushions contain energy absorbers that transform the kinetic energy of the vehicle into internal energy of the absorbers. It is useful to define the efficiency,  $\eta$ , of the energy absorbers in terms of force as follows:

$$\eta = \frac{F_m}{F_{max}} = \frac{1}{F_{max}} \int_0^s F(x) dx = \frac{a_m}{a_{max}} \quad (1)$$

where  $F(x)$  is the force required to deform the energy absorber,  $x$  is the deformation of the energy absorber, and  $s$  is the maximum deformation that undergoes the absorber. If the absorber works during an impact with a vehicle, it is clear that the efficiency of the absorber equals the ratio of the mean deceleration during the impact and the maximum deceleration during the impact.

Referring to a frontal impact the EN 1317 gives us a limit for  $a_{max}$ :

$$a_{max} < 16.8 g = 12 g \text{ ASI}_{max}$$

where  $\text{ASI}_{max} = 1.4$ . According to this approach, the minimum length of crash cushion can be easily predicted, once the desired ASI and the efficiency of the energy absorber are known:

$$X_0 = \frac{3}{2} \frac{V_0}{a_m} = \frac{3}{2} \frac{V_0 \eta}{12g \cdot \text{ASI}} \quad (2)$$

## STEEL HONEYCOMB ENERGY ABSORBER

A high-efficiency energy absorber has been developed from steel honeycomb. The honeycomb is obtained by stamping and then welding metal sheets. In [Figure 1](#), the behavior of the absorber when it undergoes plastic deformation is displayed. In [Figure 2](#), the plot of the force required to deform the honeycomb as function of its deformation is reported. The force versus displacement curve reported in [Figure 2](#) is likened to a step function; this means that the steel honeycomb behaves almost as a perfect energy absorber. Indeed, the efficiency of the energy absorbed is calculated to be about 0.92 (92%). This high efficiency allows the construction of crash cushion with a very small length according to Equation 2.

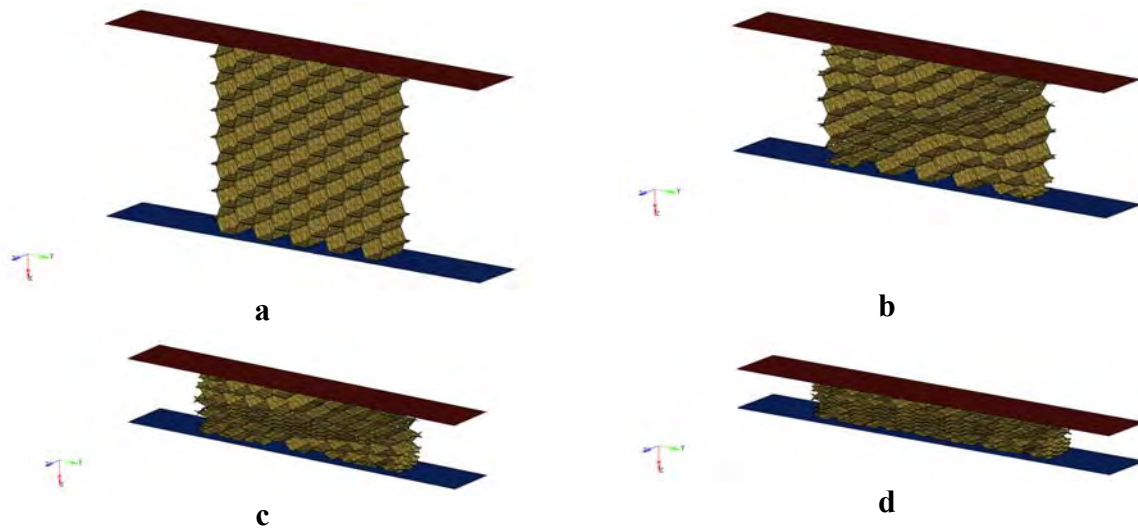

**FIGURE 1** Steel honeycomb energy absorber that undergoes plastic deformation.

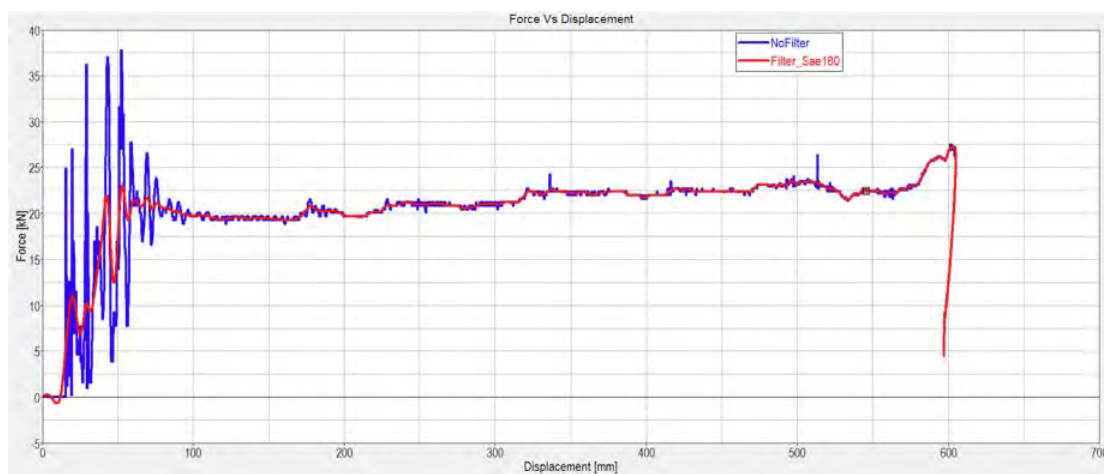

**FIGURE 2** Force versus displacement curve for the steel honeycomb energy absorber. Blue curve: data from the calculation; red curve: SAE 180 filtered curve.

## CRASH CUSHION DESIGNED FOR DIFFERENT IMPACT SPEEDS

Crash cushions for impact velocities of 50, 80, 100, and 110 km/h have been designed using a steel honeycomb energy absorber. Due to the high efficiency of the utilized energy absorber we were able to reduce the size of the crash cushions to 2.5, 3.3, 5.1, and 6.5 m for the 50, 80, 100, and 110 km/h, respectively.

The experimental crash tests have performed on the different systems at CSI-SPA in Milan. The experimental results are in perfect agreement with the numerical calculations as displayed in [Figure 3](#), where the ASI versus time is reported for the TC.2.1.80 test.

It clearly appears from Figure 2 that the ASI curve is very flat, highlighting that the crash cushion collapse in a smooth way without showing dangerous peak in the deceleration signal. This means that the biomechanical parameters will also show a significant improvement as proved by our numerical calculations that simulate the dummy crash test and use as input the acceleration signal of the vehicle measured during the experimental crash test performed at CSI-SPA. In conclusion, the use of high-efficiency energy absorber allows developing crash cushions with a reduced length and, more importantly, improving the safety as measured by biomechanical parameters like head injury criteria.

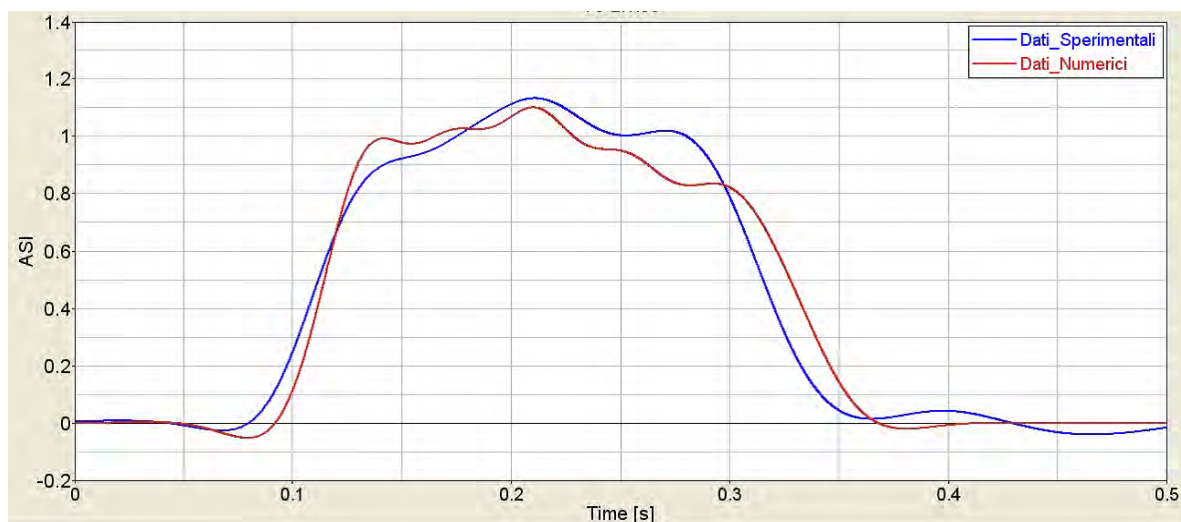

**FIGURE 3** ASI versus time for the TC.2.1.80 crash test. The red curve indicates numerical results and the blue curve indicates experimental results.

## SESSION 4: NEW ROAD SAFETY PRODUCTS

## Development of N2–H1 Performance-Level Guardrail *Crash Testing and Simulation*

ALI OSMAN ATAHAN

AYHAN O. YUCEL

ORHAN GUVEN

*Mustafa Kemal University, Turkey*

In this paper development details of a new lightweight N2-H1 performance level guardrail, called AG04, is explained. A series of computer simulations and crash tests were performed for the crashworthiness evaluation of the AG04 system. A nonlinear multipurpose 3-D finite element code, LS-DYNA, was used for the crash test simulations. After two failed crash tests necessary modifications were made and AG04 guardrail successfully met the criteria outlined in European Normative (EN) 1317-1 and 2. AG04 achieved N2-W3-A and H1-W4-A performance levels when breakaway bolts were used between post and rail. Crash test results showed that AG04 system with both A and B type W-beam rails performed similarly, which indicated either rail type can be used for an acceptable performance. It was concluded that properties of post-to-rail bolt and details of 10,000-kg truck are the most critical parameters for a satisfactory crash test performance for the AG04-2.0 barrier.

### INTRODUCTION

Since 2011 all roadside safety hardware installed in Turkey are required to comply with EN 1317 (1, 2). Currently only old German guardrail systems are in widespread use in Turkey (3). However, due to the increased demands for more roads (an additional 15,000 km until year 2023) there is an increased interest to develop new generation lightweight and cost-effective guardrail designs.

A majority of the guardrail systems used in Turkey are H1-level guardrails, an old German design called EDSP-1.33 (4). Recently the largest guardrail manufacturing company in Turkey, ALKA Group, started the initiative for developing lightweight, new generation H1-level guardrails as an alternative to the EDSP-1.33 system (4). A system called AG04-2.0 with N2-W3-A and H1-W4-A performance levels was developed, which is equal to the performance of EDSP-1.33. The rest of this paper details the development process of AG04-2.0 guardrail system.

### COMPARISON OF EDSP-1.33 AND AG04-2.0 GUARDRAILS

As shown in Figure 1, EDSP-1.33 uses five different components and this design has many disadvantages over the recently developed AG04 shown in Figure 2. These differences are (a) the weight of EDSP-1.33 is almost twice as heavy as AG04-2.0; (b) production of the spacer for EDSP system is fairly challenging due to its geometry; (c) the width of AG04 is fairly small, allowing its use at locations where EDSP-1.33 cannot be used; and (d) installation time for EDSP-1.33 takes twice as long as AG04-2.0 due to its connection complexity.

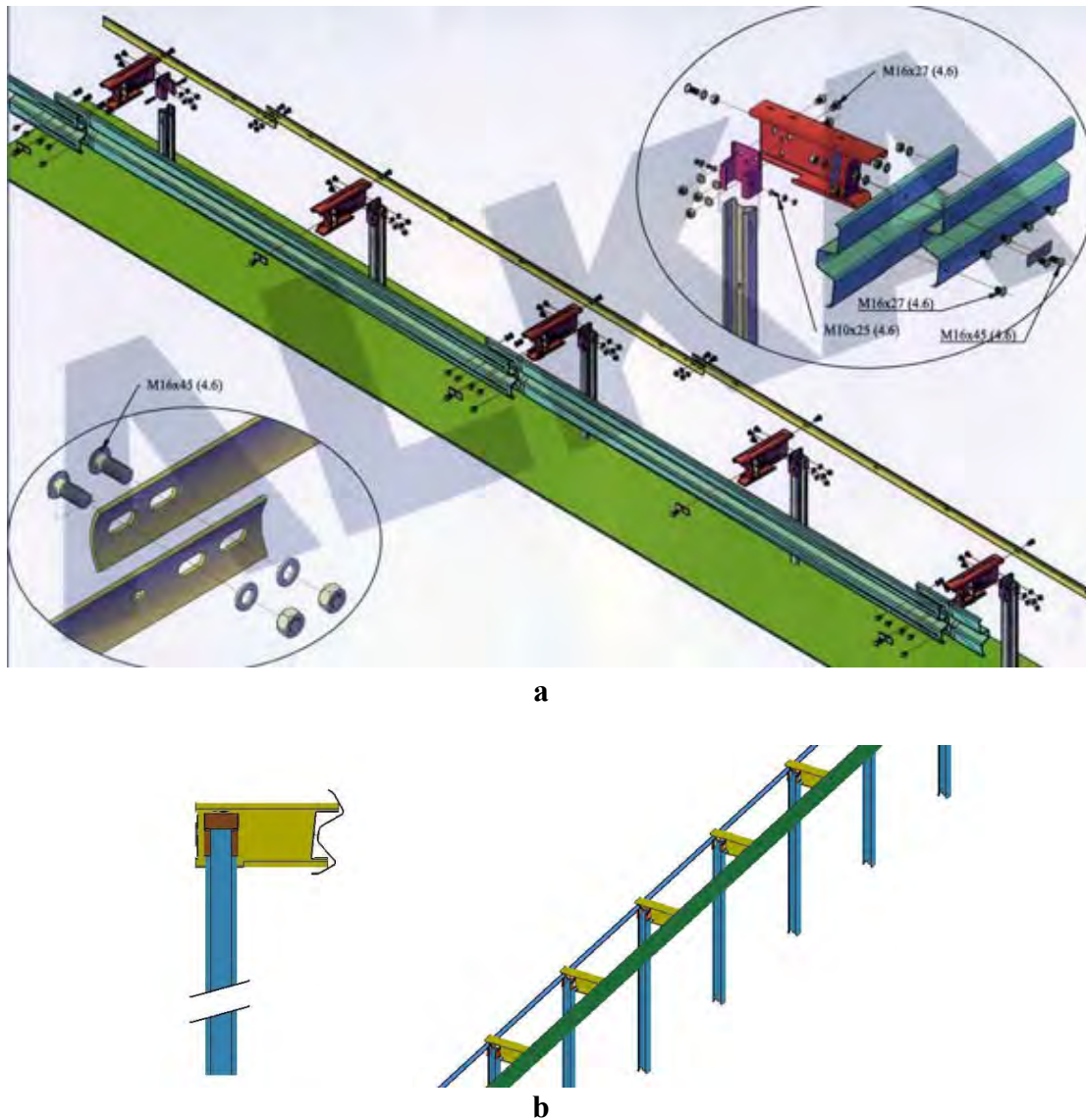

**FIGURE 1 EDSP-1.33: (a) guardrail components and (b) finite element model (4).**

As shown in Figure 2, AG04 guardrail has only three components. These are C125 x 62.5 posts, standard A- or B-type W-beam rail, and connecting bolts. Three different class of steel, S235JR, S275JR, or S355JR, were used in AG04 components. Depending upon the request, AG04 guardrail can include A-type or B-type W-beam rail. Figure 3 shows the difference between these two rails. Previous simulation studies showed that both rails are considered to be equivalent and they can be used interchangeably without further evaluations. However, no crash test data is available to prove this finding. This study is intended to verify this prediction.



## LS-DYNA AND CRASH TEST RESULTS

In this study a series of LS-DYNA simulations and crash tests were performed to achieve the following goals: (a) develop a new generation, lightweight N2-H1 performance-level guardrail; (b) determine the EN 1317-2 suitability of newly developed AG04 system through full-scale crash testing; (c) validate the accuracy of the finite element models of the AG04 system; and (d) observe and compare the performances of A- and B-type W-beam rails.

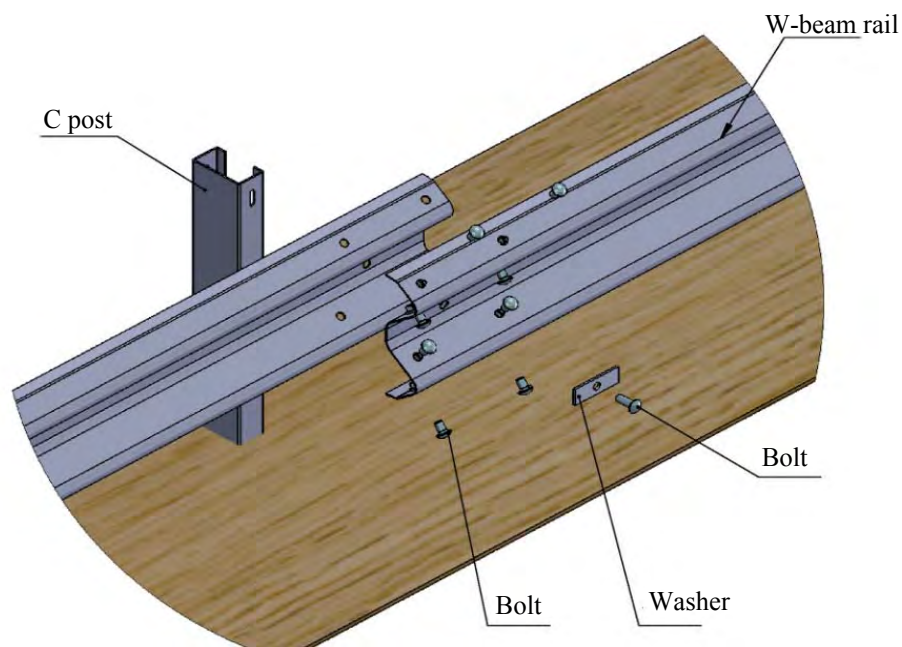

**a**

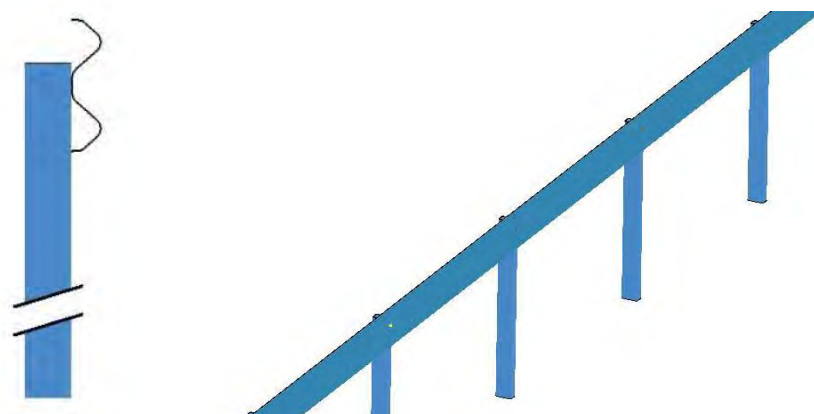

**b**

**FIGURE 2** AG04-2.0: (a) guardrail components and (b) finite element model (4).

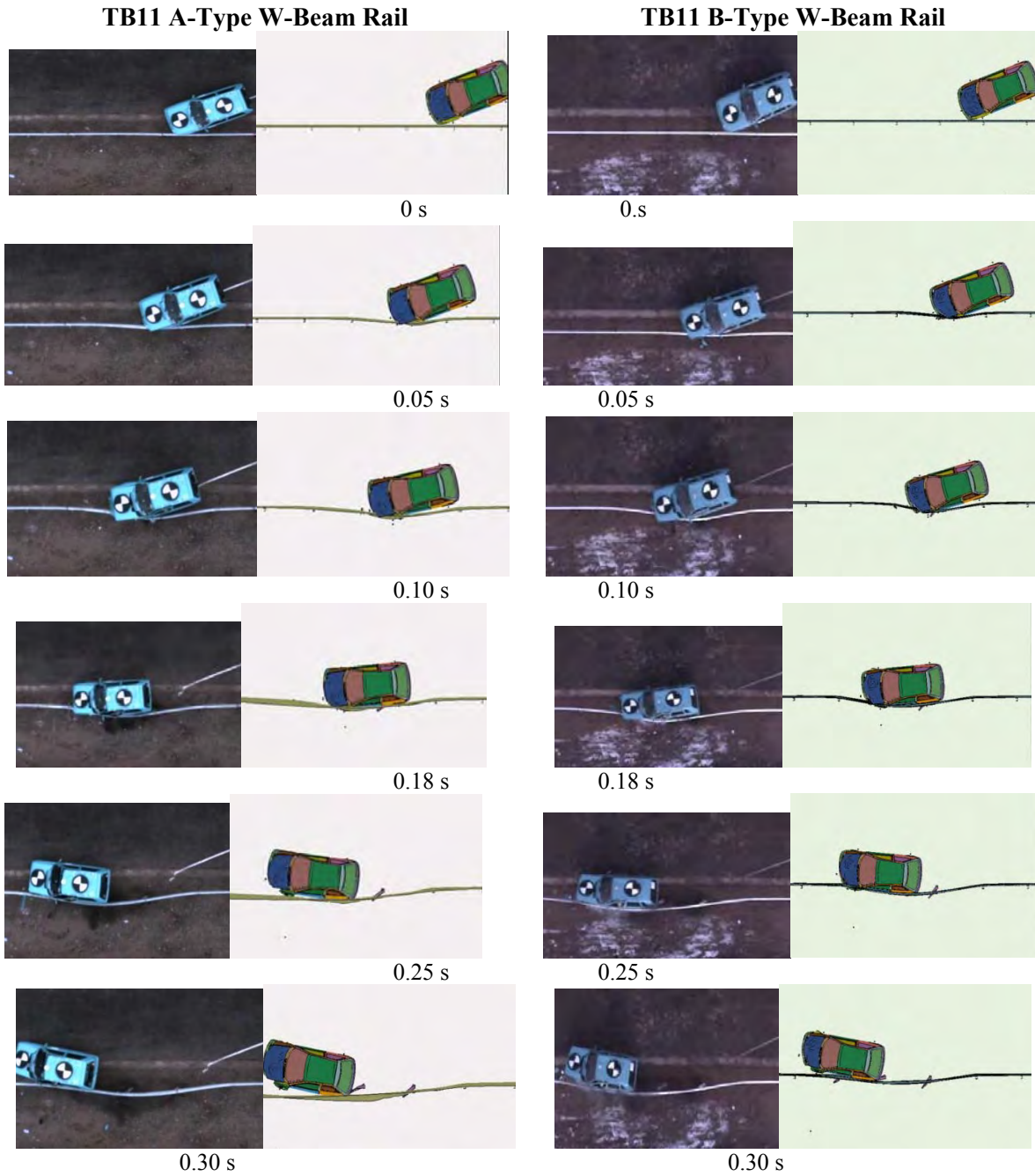

**FIGURE 3 TBLL crash test and LS-DYNA simulation comparison for AG04-2.0 guardrail.**



A total of six successful and two unsuccessful crash tests were performed on AG04-2.0 guardrail system (5). Details of these tests are depicted in Table 1. As shown in this table results obtained from TB11, TB32, and TB42 tests for A- and B-type rails were found to be very similar. On the other hand, finite element simulations of these crash tests were also very predictive to observed dynamic behavior of the barrier. Figures 3 through 5 show comparisons between full-scale crash tests and simulation results for all the tests. It was found that bolt modeling in LS-DYNA is very accurate in representing the actual bolt fracture observed in full-scale crash tests (6).

## DETAILS OF UNSUCCESSFUL TESTS ON AG04-2.0 GUARDRAIL

In the development process of AG04-2.0 system, two TB42 tests failed. The first test failed due to the rigid post-to-rail connection. As shown in Figure 6, in this design, strong M16-grade 8.8 bolts with a large washer was used to connect C125 posts to W-beam rail. Due to the presence of the washer, the posts were not separated from rail in TB42 test. Eventually, as shown in Figure 6, excessive tensile loads in the bolt forced the bolt and washer in the W-beam slot which caused the rail rupture. This test clearly showed that a non-failing post to W-beam rail is not an acceptable connection option for AG04 design. This design flaw was corrected in modified design and, in the next test, AG04-2.0 passed the TB42 crash test criteria specified in EN 1317-2 (2).

The second TB42 test failed due to the 10,000-kg truck properties. Even though the truck used for the TB42 test was a standard vehicle, its frontal bumper and side structure caused the truck to override the 750-mm high W-beam rail. A subsequent test with the identical barrier passed the TB42 test when a more friendly truck was used. This result clearly proved that a better vehicle selection criterion is needed for more uniform evaluation of roadside safety hardware.

**TABLE 1 Crash Test Details on AG04-2.0 Guardrail**

<b>Successful Crash Tests on AG04-2.0</b>						
	<b>Vehicle Type</b>	<b>Speed (km/h)</b>	<b>Angle (degree)</b>	<b>Result</b>	<b>Comment</b>	<b>Performance Level</b>
<b>A-Type W-Beam Rail</b>						
TB11	Car	100	20	ASI = 0.94	A	N2-W3-A H1-W4-A
TB32	Car	110	20	W = 1,000 mm	W3	
TB42	Truck	70	15	W = 1,300 mm	W4	
<b>B-Type W-Beam Rail</b>						
TB11	Car	100	20	ASI = 0.7	A	N2-W2-A H1-W4-A
TB32	Car	110	20	W = 810 mm	W2	
TB42	Truck	70	15	W = 1,250 mm	W4	
<b>Unsuccessful Crash Tests on AG04-2.0</b>						
TB42	Truck	70	15	Failure due to rail rupture		
TB42	Truck	70	15	Failure due to vehicle override		

TB32 A-Type W-Beam Rail



0 s



0.10 s



0.18 s



0.25 s



0.35 s



0.45 s

TB32 B-Type W-Beam Rail



0 s

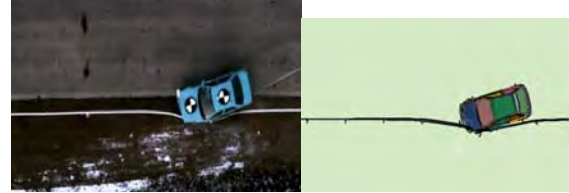

0.10 s



0.18 s



0.25 s



0.35 s



0.45 s

**FIGURE 4 TB32 crash test and LS-DYNA simulation comparison for AG04-2.0 guardrail.**

**TB42 A-Type W-Beam Rail**

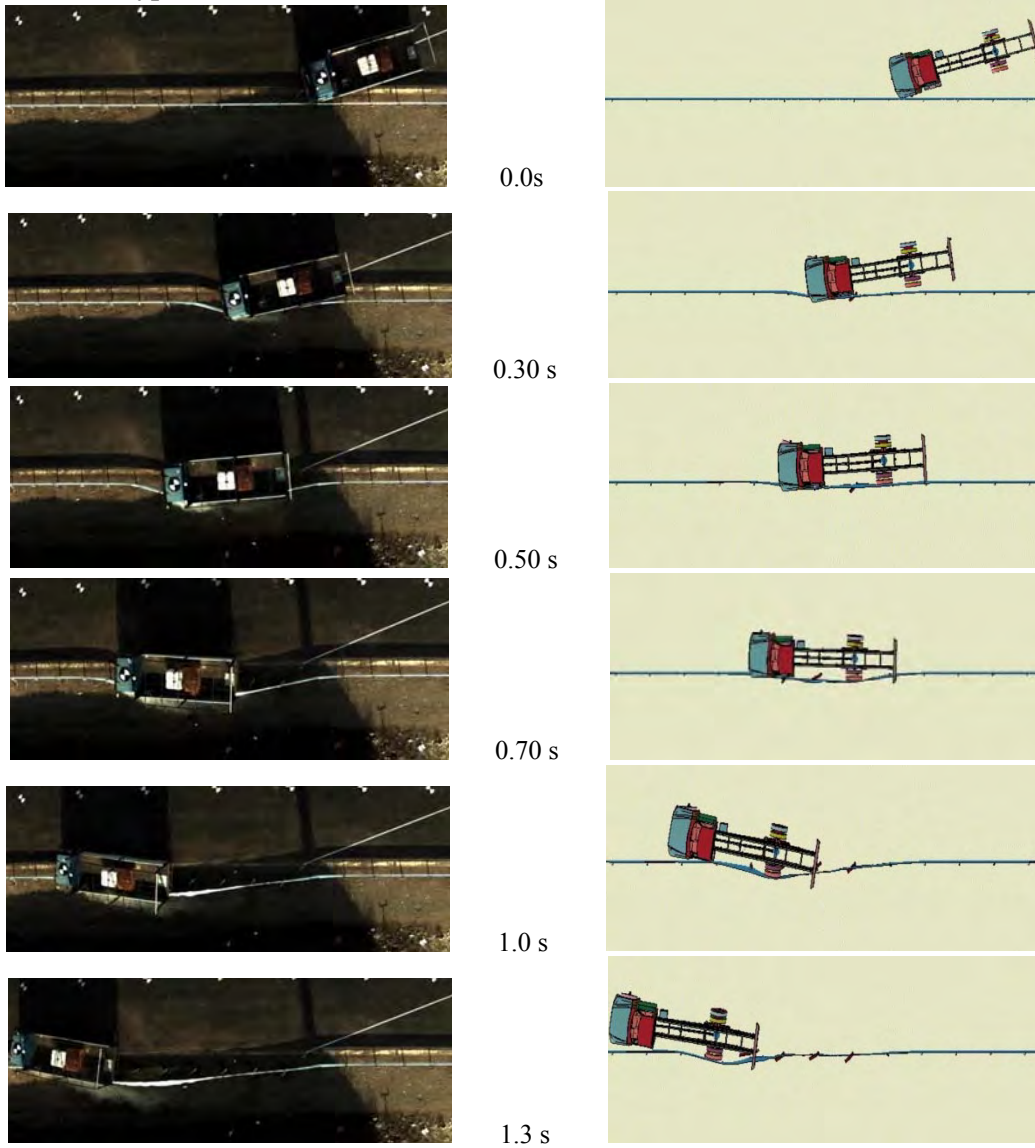

**FIGURE 5a** TB42 crash test and LS-DYNA simulation comparison for AG04-2.0 guardrail, A-type W-beam rail.

**TB42 B-Type W-Beam Rail**

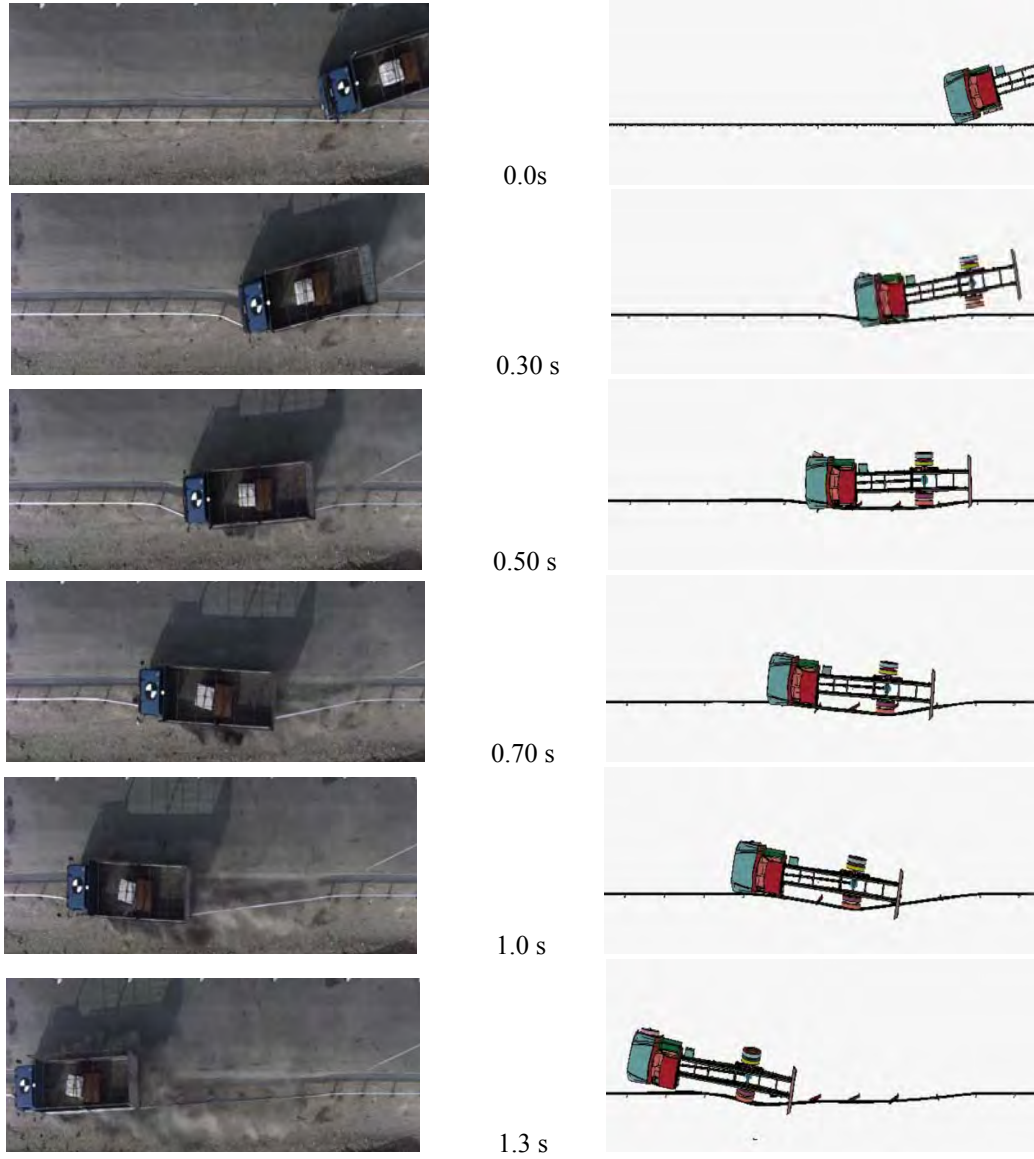

**FIGURE 5b** TB42 crash test and LS-DYNA simulation comparison for AG04-2.0 guardrail, B-type W-beam rail.



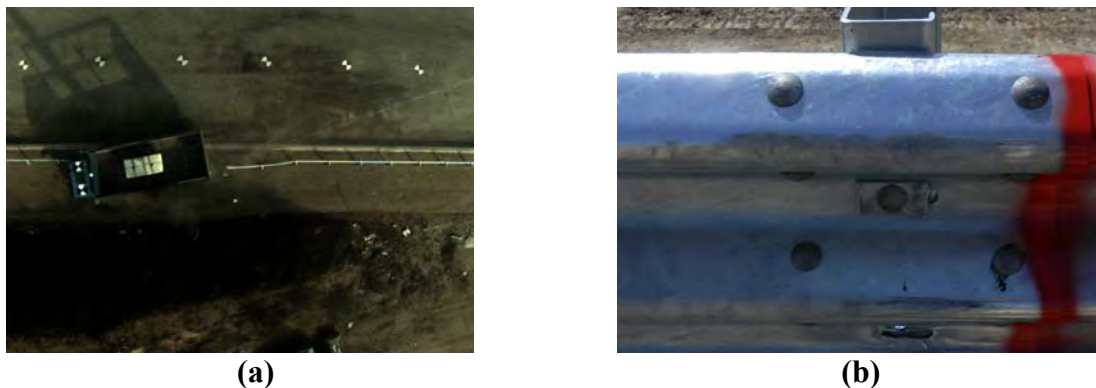

**FIGURE 6 (a) W-beam rail rupture in TB42 test and (b) large washer and nonfailing M16 grade 8.8 bolts used in post-to-rail connection.**

## CONCLUSIONS

Based on the study, the following conclusions were reached.

1. A new generation, lightweight, and competitive N2-H1 level guardrail, AG04-2.0, was developed using extensive finite element simulations and full-scale crash tests.
2. It was interesting to see that A- and B-type W-beam rails performed very similarly. Both performed H1-W4-A in H1 performance level. For the N2 level, the difference between test results was no more than standard deviation. This result suggests that A or B rails can be used interchangeably. No extra crash test should be required when rail is replaced.
3. In light guardrail designs, such as AG04-2.0, performance of bolted connection between post and W-beam rail is crucial for an acceptable crash test behavior.
4. It was observed that truck properties could have a significant influence on the crash test results. Same truck with different frontal and side properties changed the crash test behavior of AG04-2.0 guardrail.
5. Similar to U.S. practice, it is recommended to better control vehicle specifications in EN 1317 for more uniform evaluation criteria.
6. Finally, LS-DYNA simulation results showed that finite element models used for AG04-2.0 barrier, such as breakaway bolts, are found to be fairly accurate in representing the crash test behavior of AG04-2.0 guardrail.

## REFERENCES

1. Turkish Standardization Committee, Regulations for European Norms, Ankara, 2012.
2. European Committee for Standardization. EN 1317-1 and 2: Road Restraint Systems, Comité Européen de Normalisation, Brussels, Belgium, 2010.
3. RAL RG620. Road Restraint Systems: Overview of Systems Tested in Accordance with EN 1317-2, Germany, 2000.
4. ALKA Guardrail Manufacturing Company, Istanbul, Turkey, 2011. [www.alkagroup.com.tr](http://www.alkagroup.com.tr).
5. CSI Crash Test Facility. Test No. 0135\_me\_hrb\_11, TB11 and TB42 crash tests, CSI-SPA, Bollate, Italy.
6. LS-DYNA 971 User's Manual, Livermore Software Technology Corporation, Calif., 2011.

## SESSION 4: NEW ROAD SAFETY PRODUCTS

**Risks of Unprotected Median Drainage Ditches on Vehicle Stability**

ALI OSMAN ATAHAN

AYHAN O. YUCEL

ORHAN GUVEN

*Mustafa Kemal University, Turkey*

In this study, potential risks of unprotected triangular and trapezoidal cross-sectional median drainage ditches on vehicle stability was investigated. Dynamic simulations were carried out to determine the safety concerns and suggest appropriate countermeasures. Drainage structures geometry, characteristics of vehicles entering the ditches, vehicle approach angle and velocity were described as variables for the analysis. Finite element analysis program LS-DYNA was used to simulate the dynamic interaction between vehicle and ditch. Based on the analysis results it was determined that vehicles tend to either: (a) rollover or enter opposing lanes in uncontrolled manner or (b) remain inside the ditch when the velocity and encroachment angle is low. To provide required level of safety and security at drainage ditches use of guardrail was also investigated. Based on the crash simulations it was concluded that when guardrail location is correctly selected the H1-level guardrail provided acceptable performances with respect to vehicle stability.

**INTRODUCTION**

In recent years, more than 5,000 km of low-volume roadways have been constructed in Turkey. A cross-section view of these highway platforms is depicted in [Figure 1](#) (1, 2). As shown in this figure, the roadway is consisted of two separate lanes and a fairly narrow median connecting both lanes. These medians are mostly used as a means of draining rainwater and made out of concrete. To achieve the desired water flow they were constructed as a ditch and, as shown in [Figure 2](#), they were either in triangular or trapezoidal shape. Existence of these ditches in highway platform creates a discontinuity on the road surface and a potential accident risk for errant vehicles encroaching on the roadway and entering these ditches (3).

The aim of this study is threefold: (a) determination of risks involving unprotected triangular and trapezoidal cross-sectional median drainage ditches on vehicle stability; (b) assessment of level of safety and security for H1 safety level guardrail when applied at different locations at these ditches; and (c) recommendation of acceptable solutions to alleviate crash risks.

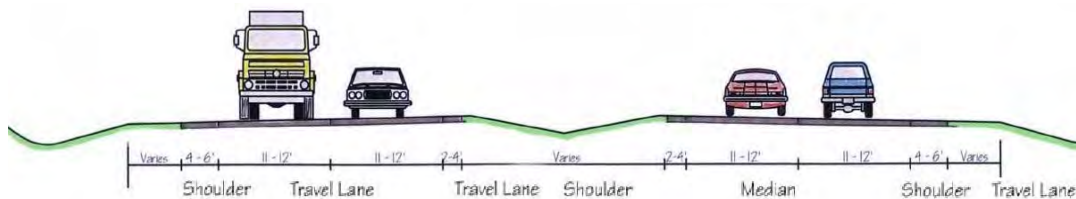

**FIGURE 1 Cross-section view of low-volume highway platform.**



**FIGURE 2 (a) Triangular-shaped ditch and (b) trapezoidal-shaped ditch at median.**

## RESEARCH WARRANTS

Previous studies showed that roadside ditches constructed steeper than a 1H:4V slope could present risks for entering vehicles (4–6). As shown in Figure 2, there are two types of ditches commonly used in Turkey on low-volume roads. These triangular- and trapezoidal-shaped ditches are mainly used for rainwater drainage. Real-life experiences show that these ditches are able to drain rainwater thus improving road safety. However, introducing a discontinuity between the roadway lanes could create additional risks for vehicles entering these ditches. Even though similar research attempts have investigated the effect of wide medians on safety (7–9), very few studies investigated the effect of ditches at narrow medians on vehicle stability.

## DETAILS OF COMPUTER SIMULATION STUDY

In this research, a detailed computer simulation study was performed to investigate the potential risks of unprotected triangular and trapezoidal cross-sectional median drainage ditches on vehicle stability. LS-DYNA, a versatile finite element code (10) that is able to capture dynamic interaction between vehicle and ditch, is used. Finite element models of three different vehicle types, a 900-kg automobile, a 3,000-kg van, and a 10,000-kg truck, were obtained from the National Crash Analysis Center at George Washington University (11) and used in the study. To cover a variety of conditions, the velocities for these vehicles were 50, 70, 90, and 110 km/h and the angle of entrances to the ditch were 5, 15 and 25 degrees. Friction between the tires and the concrete or asphalt road surface were also varied to compare the effect on vehicle friction. A picture representing one of the simulations is shown in Figure 3.

## VEHICLE–DITCH DYNAMIC INTERACTION SIMULATION RESULTS

A total of 100 LS-DYNA simulations were performed to evaluate the effect of ditch geometry, friction, and vehicle mass, velocity, and angle on trajectory of vehicle. Results show that vehicles: (a) in most of the cases, vehicles crossed the ditch and entered the opposing lanes in uncontrolled manner; (b) the vehicle sometimes rolled over at inside or outside the ditch; and



(c) the vehicle rarely remained inside the ditch. Pictures showing the behavior of the vehicles in each case are shown in [Figure 4](#). Based on the results, it was determined that with under current conditions it is not possible to provide safety for vehicles entering the ditches. Moreover, geometry of ditch, triangular or trapezoidal, did not have significant influence on the simulation outcome. Hence, the next phase of the study, which included implementation of proper guardrails, was initiated.

## PROTECTION OF DITCHES WITH PROPER GUARDRAIL

Based on the statistical information, 10,000-kg trucks are the most frequently used heavy vehicles on low-volume roads in Turkey. So in this study 10,000-kg truck models were used in simulating vehicle–guardrail dynamic interaction and in selection and placement considerations of guardrails. According to EN 1317 crash test standards, these barriers represented H1-level barriers (11).

As shown in [Figure 5](#), in this phase of study two different H1 performance level guardrails were evaluated. The first design is old German design, EDSP-1.33, and the second system is the recently developed AG04-2.0 system. Both systems have previously crash tested and they were classified as H1-W4-A.

A series of LS-DYNA simulations were performed on triangular and trapezoidal ditches protected with both EDSP-1.33 and AG04-2.0. As shown in [Figure 6](#), these barriers were placed at four different locations to evaluate the effect of location on performance. These locations are: (1) inside the ditch, (2) at slope break point, (3) 30 cm away from slope break point, and (4) 50 cm away from slope break point. A 10,000-kg truck impacted the barriers at 70 km/h and a 15 degree angle. These impact conditions are taken from EN 1317-2 standard for 10,000-kg truck case (5).

## RESULTS AND RECOMMENDATIONS

[Figures 7](#) and [8](#) show results of 10,000-kg truck impact simulations on both H1-level guardrails. Based on the simulation results it was determined that H1-level guardrails evaluated in this study could provide the desired level of protection at median drainage ditches when placed at a minimum 50 cm away from ditch slope break point. Rest of the cases resulted vehicle stability problems and eventually truck rollover. Based on this finding utilization of new generation guardrail system AG04-2.0 is strongly recommended due to its advantages, such as weight, ease of production, speed of construction over EDSP-1.33 system.

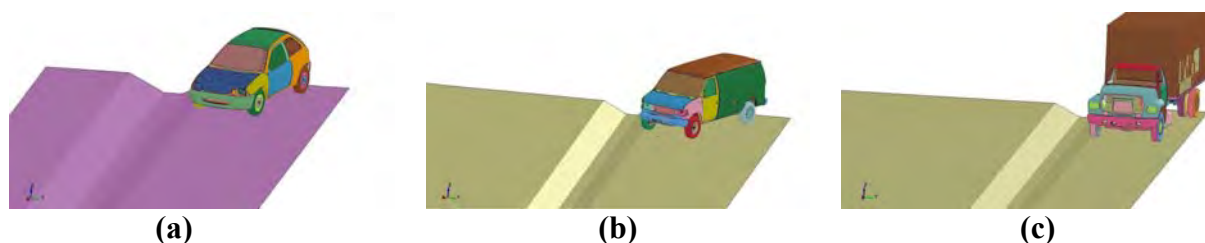

**FIGURE 3** Finite element model of ditch and vehicles used in the simulations: (a) 900-kg automobile, (b) 3,000-kg van, and (c) 10,000-kg truck.

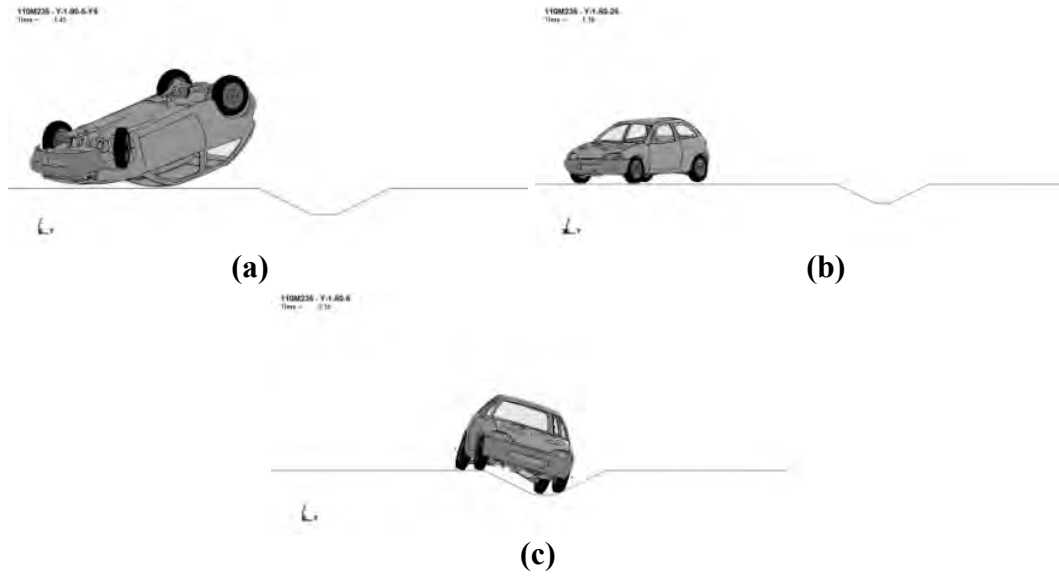

**FIGURE 4** Results of vehicle-ditch interactions: (a) vehicle rollover, (b) entering opposing lanes, and (c) remaining inside the ditch.

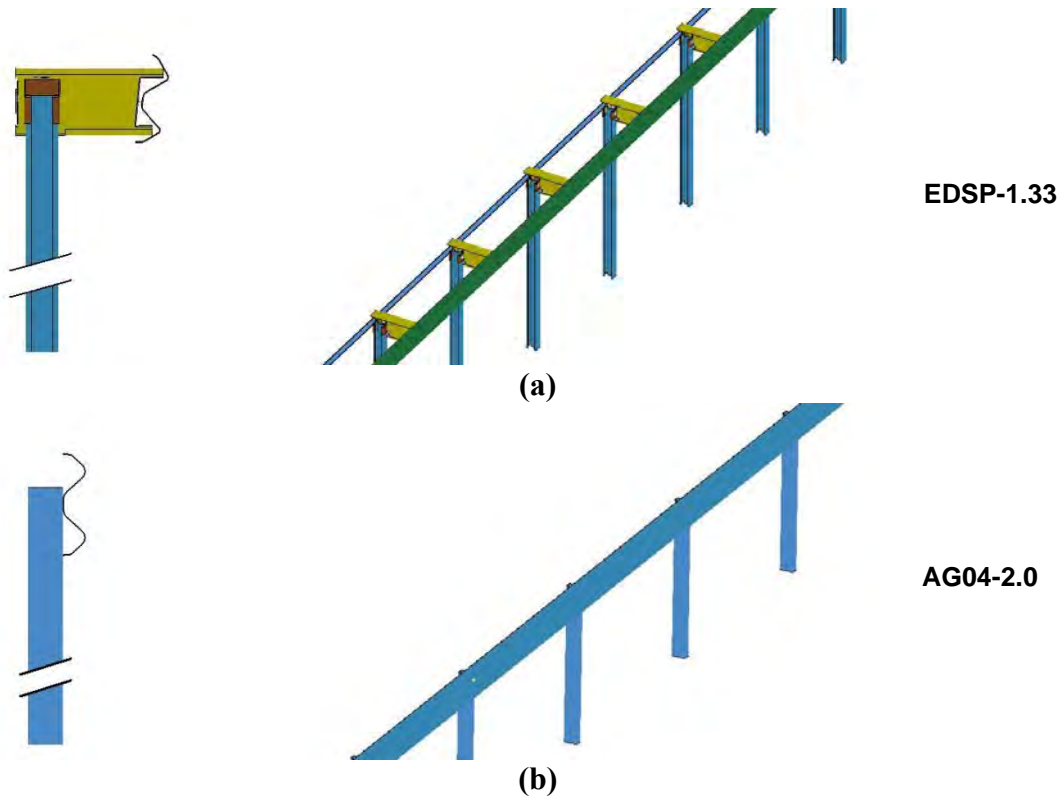

**FIGURE 5** Details of two H1-level guardrails used in this study: (a) EDSP-1.33 and (b) AG04-2.0.

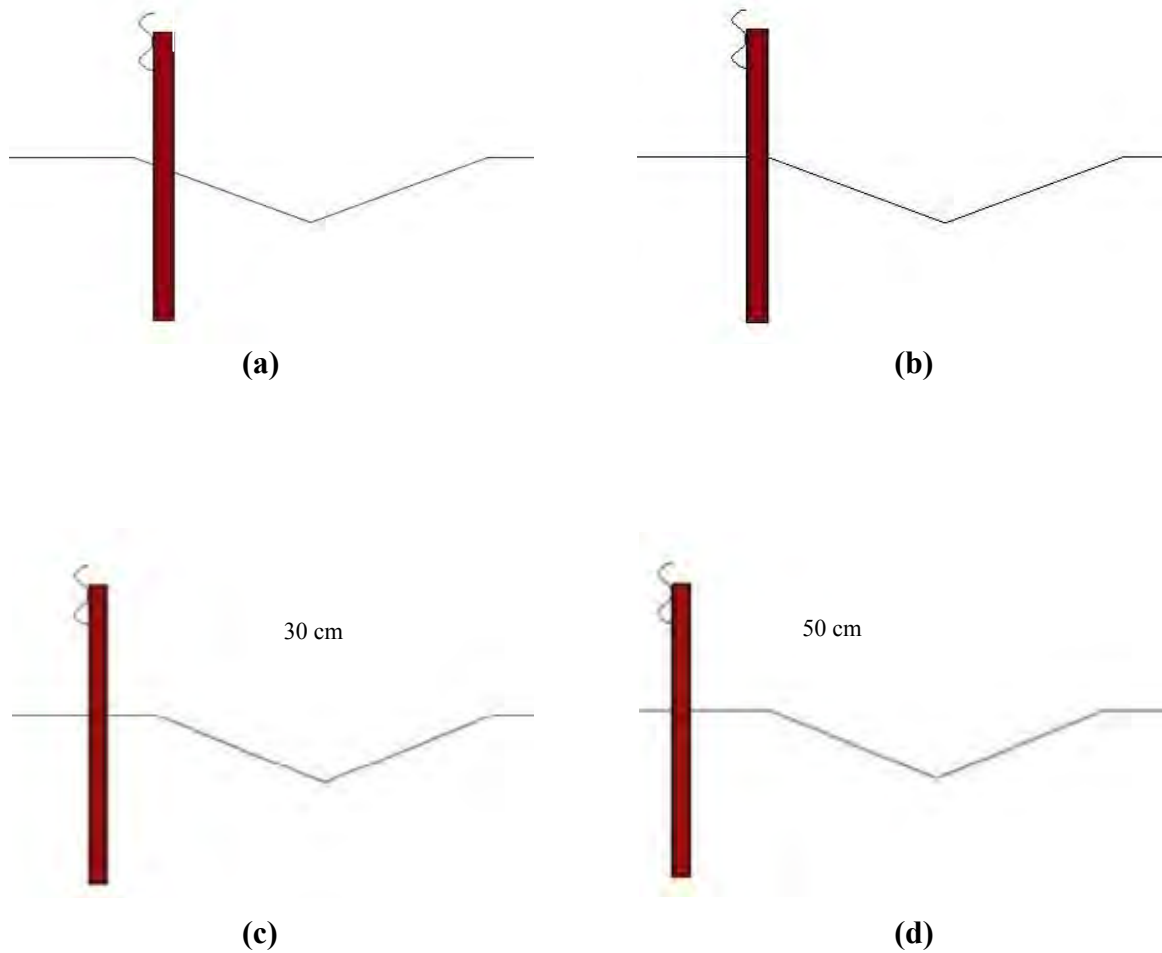

**FIGURE 6** Barrier placement details (a) barrier inside ditch, (b) barrier at slope break point, (c) barrier 30 cm away from slope, and (d) barrier 50 cm away from slope.

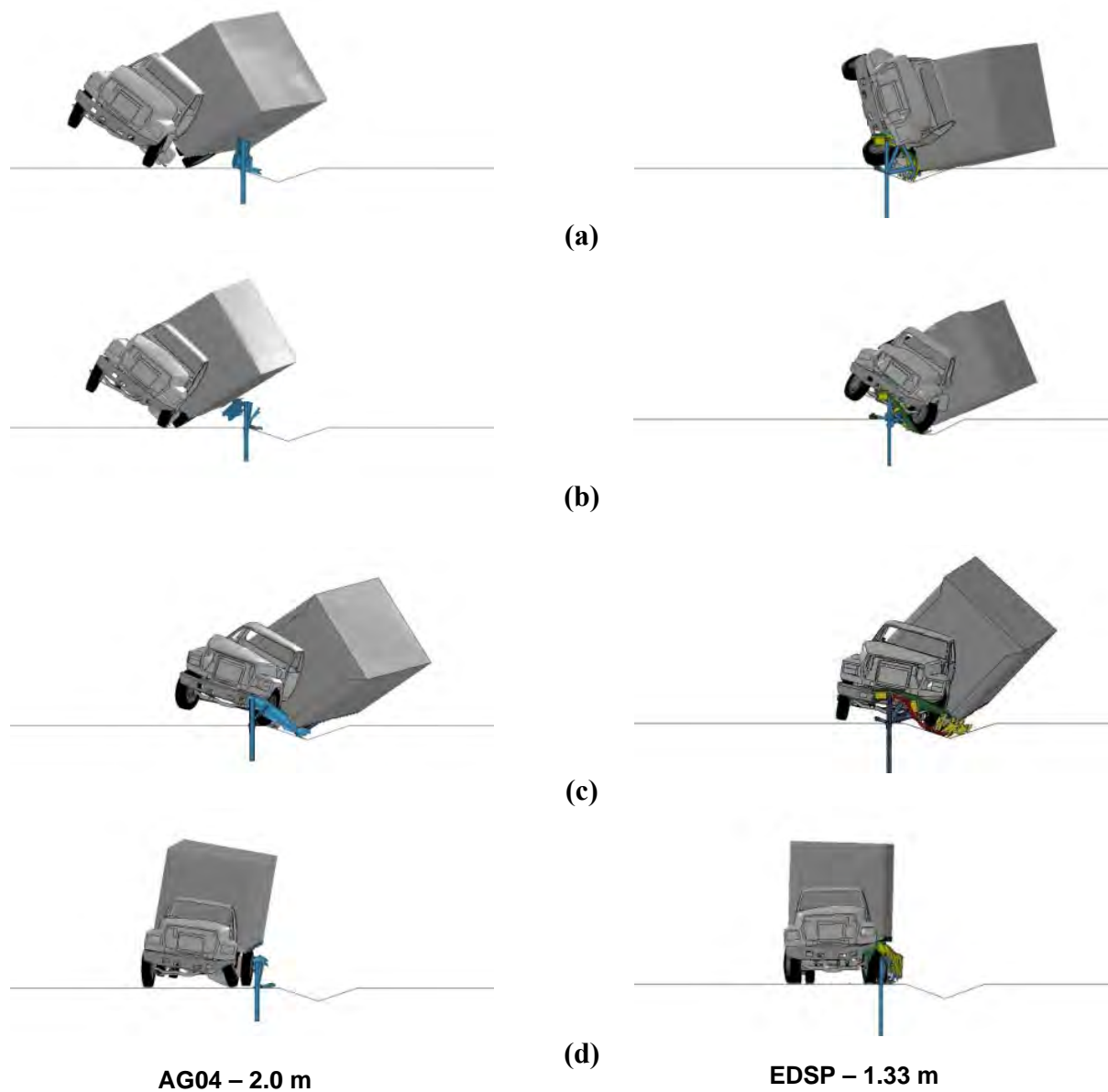

**FIGURE 7** Results of guardrail impact for triangular ditch (a) inside the ditch, (b) at slope break point, (c) 30 cm away from slope break point, and (d) 50 cm away from slope break point.

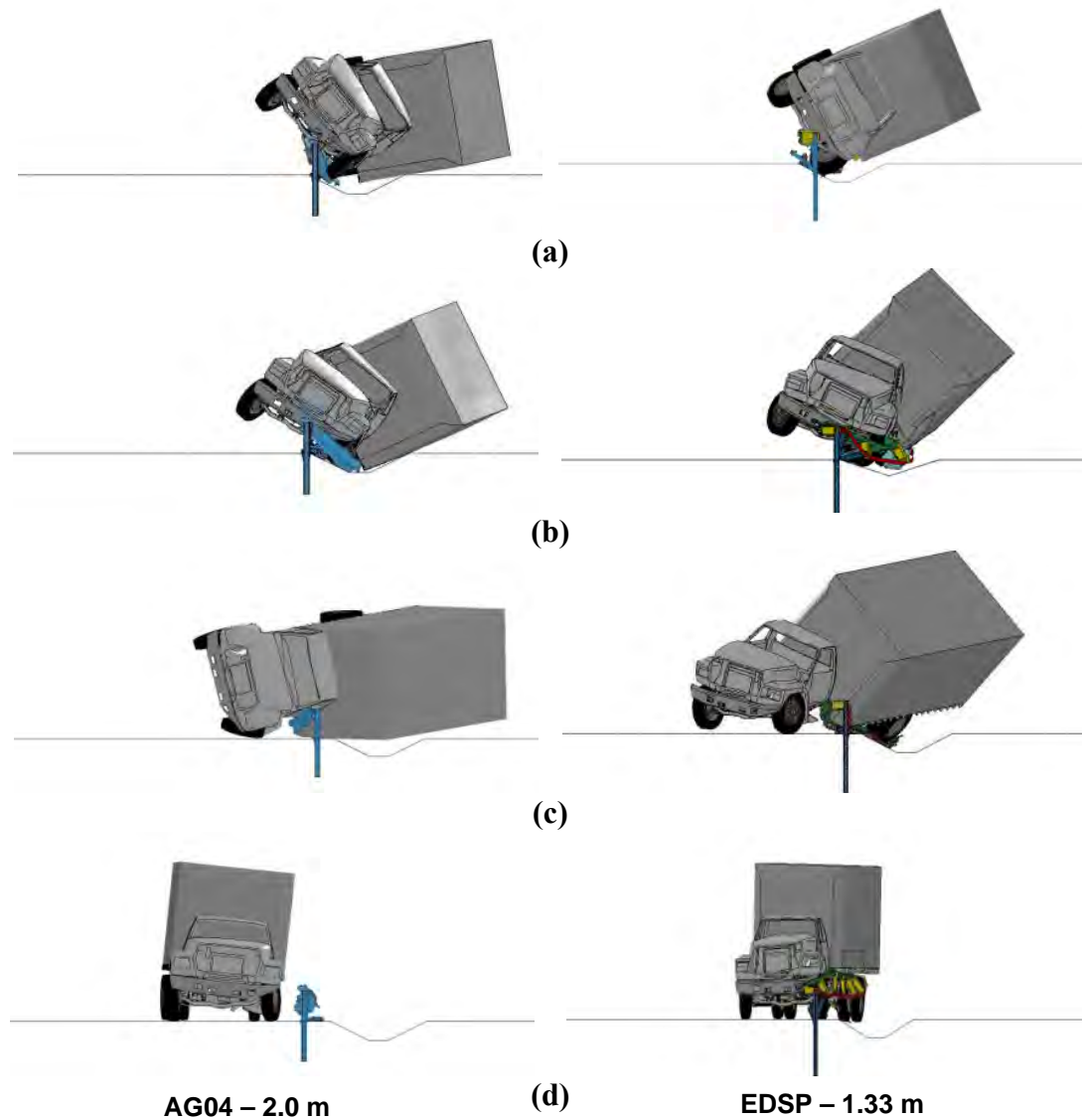

**FIGURE 8** Results of guardrail impact for triangular ditch (a) inside the ditch, (b) at slope break point, (c) 30 cm away from slope break point, and (d) 50 cm away from slope break point.

#### ACKNOWLEDGMENT

Financial support for this project was provided by the Turkish Scientific Committee, Tübitak, and ALKA company.

**REFERENCES**

1. *Highway Design Manual for Low Volume Roads*. Turkish National Roads Directorate, KGM, Ankara, 2005.
2. Median Configurations in Divided Roads. Turkish National Roads Directorate, Ankara, 2011.
3. Yucel, A. O. Risks of Unprotected Median Drainage Ditches on Vehicle Stability. Master's thesis. Mustafa Kemal University, 2012.
4. Stamatiadis, N., J. G. Pigman, J. Sacksteder, W. Ruff, and D. Lord. Impact of Shoulder Width and Median Width on Safety. *NCHRP Report 633: Impact of Shoulder Width and Median Width on Safety*, Transportation Research Board of the National Academies, Washington, D.C., 2009.
5. Sheihh, N. M., and R. P. Bligh. Analysis of the Impact Performance of Connet Median Barrier Placed on or Adjacent to Slopes. Report No. 0-5210. Texas Transportation Institute, College Station, 2006.
6. Marzougui, D., P. Mohan, U. Mahadevaiah, and C. D. Kan. Performance Evaluation of Three Strand Cable Barriers Installed on Sloped Terrains. National Crash Analysis Center Report 2007-R-005. George Washington University, 2007.
7. Marzougui, D., P. Mohan, C. D. Kan, and K. Opiela. Performance Evaluation of Low Tension Three-Strand Cable Median Barriers. In *Transportation Research Record: Journal of the Transportation Research Board*, No. 2025, Transportation Research Board of the National Academies, 2007, pp. 34–44.
8. Miaou, S.-P., R. P. Bligh, and D. Lord. Developing Guidelines for Median Barrier Installation: Benefit–Cost Analysis with Texas Data. In *Transportation Research Record: Journal of the Transportation Research Board*, No. 1904, Transportation Research Board of the National Academies, Washington, D.C., 2005, pp. 3–19.
9. Marzougi, D., K. S. Opeila, and C. D. Kan. Effects of Cable Barrier Design and Placement on Safety Performance for Varying Median Configurations. National Crash Analysis Center, George Washington University, 2009.
10. Livermore Software Technology Corporation. *LS-DYNA 971 User's Guide*, LSTC, Livermore, Calif., 2010.
11. National Crash Analysis Center, George Washington University, Va., 2010. Available at <http://www.ncac.gwu.edu/vml/models.html>.
12. EN 1317: European Standard for Road Restraints Systems: Performance Classes, Impact Test Acceptance Criteria and Test Methods for Safety Barriers, Brussels, Belgium, 2010.



## SESSION 4: NEW ROAD SAFETY PRODUCTS

## How High-Friction Surfacing Treatments Combined with Other Safety Hardware Installations Save Lives Globally

JOHN LEFANTE  
*DBI Services*

In 2009 there were approximately 200,000 severe road traffic accidents in Great Britain, of which 2,057 resulted in fatal injuries. Similarly in the United States there are approximately 10.8 million road traffic accidents in which 30,797 result in a fatality. The estimated costs are £18 billion in the United Kingdom and \$164 billion in the United States. Although these are alarming statistics there is a commonality in both Great Britain and the United States: these numbers have been and continue to decline yearly. In fact, in Great Britain in 2010 the casualty rate declined by 17%. In the United States it declined 3% over the same period and declined by 25% over the last 5 years.

There are quite a few reasons for this decline. Safety innovations have been one of the leading factors in the decline of these statistics. It has been estimated that 53% of all fatal accidents are due to roadway departures. There are several reasons for roadway departures to occur. The four major reasons are roadway conditions, collision avoidance, vehicle failure, and driver error. At least three of these may be impacted by safety improvements within the road surface that can increase the coefficient of friction. By increasing this friction coefficient there is a reduced likelihood that a vehicle will leave the roadway. One proven safety method is the use high-friction surface treatments (HFST).

HFSTs were developed in Europe more than 30 years ago under an industry- and government-sponsored safety program. In the last 15 years the FHWA has supported these treatments under their horizontal curve low-cost crash reduction program. The HFST system is engineered to resolve the issue of low friction on pavements through the installation of a high-friction surface on site-specific pavement locations. HFST utilizes special high-friction aggregates that alerts drivers to traffic changes, enhance traffic calming efforts, reduce run-off-the-road accidents, and most importantly, saves lives. This process has shown a proven record of crash reduction on horizontal curves, bridge decks, and intersection approaches.

HFST will bond asphalt, concrete, and other substrates. HFST has the ability to resist snowplowing and the impact of surface contaminants and still remains effective for several years. The key to this system is the aggregate utilized. Typically 1 to 3 mm of crushed bauxite is the preferred aggregate due to its angular geometry; other aggregates can be utilized as a demarcation to alert road users of an impending danger.

Currently, two processes are used: the older heated bituminous system and the cold applied resin base. The resin-based system has become more cost-efficient due to the development and utilization of specialty installation equipment. In the past this system would be costly in larger areas due to the intensive manual application of the system. With the development of automated application equipment, manual applications only are utilized for small areas of less than 200 m<sup>2</sup>.

Test data and results prove that the average stopping distances are dramatically reduced once an HFST surface has been applied. At 60 mph on wet or dry pavement, HFST can reduce

stopping distances up to 40%. This margin can make the difference in crash rate reductions at intersections, rural roads, and pedestrian walkways.

The Kentucky Transportation Cabinet (KYTC) has implemented a 3-year statewide safety improvement program using HFST at selected high-incident horizontal curve locations to improve pavement friction and reduce roadway departure crashes. The first round of results from the KYTC HFST has concluded a total crash reduction of 69% from an annual rate of 6.18 to 1.92. This is one of many such programs currently in progress throughout the United States.

HFST has been and is currently utilized in over 20 countries worldwide as a method to reduce roadway crashes and roadside departures. With a 30-year track record of saving lives, HFST has proven effective in improving the friction of various surfaces. The U.S. Department of Transportation has stated that "...70% of wet pavement crashes can be affected by friction improvements." HFST is commonly utilized in areas in which a reduction of stopping distance is warranted (intersections, roundabouts) or road departure incidents are common (horizontal curves). Most importantly, HFST saves lives.

## SESSION 4: NEW ROAD SAFETY PRODUCTS

**Development of a Recycled Substrate Material for Road Signs****JASON HUBBELL***Atlanticum Bridge Corp, Italy***LIZ WALKER***Image Microsystems*

**O**ur industry has a unique opportunity in the 21st century to contribute to the solution of the growing problem of e-waste. E-waste is growing faster than any other type of waste with an annual volume close to 40 million metric tons globally (1). That is 88.2 billion pounds. Furthermore, a 2010 United Nations study reports that the amount of e-waste could grow exponentially (2). It is estimate to grow 500 times greater over the next decade. That is another 44.1 trillion pounds.

Plastic accounts for roughly 23% of all e-waste (3). That is more than 10 trillion pounds of e-plastic per year. Primarily this is acrylonitrile-butadiene-styrene (ABS) plastic which contains ultraviolet inhibitors and brominated flame retardants and is virtually nonbiodegradable. For every 500 million computers that are thrown out there are 6.32 billion pounds of plastic, 1.58 billion pounds of lead, 3 million pounds of cadmium, 1.9 million pounds of chromium, and 632,000 pounds of mercury (3).

Plastic is by far the greatest portion of the e-waste. So what is typically done with all this plastic? The “dirty” plastic is generally considered valueless in the downstream recycling supply chain. Typically, this plastic ends up in landfills, incinerated, and a large percentage of e-waste from the developed countries is exported to developing countries (Figures 1 and 2). The landfilling, transportation, and handling costs and the environmental cost are incalculable.

**FIGURE 1 Postconsumer e-waste disposal.**



**FIGURE 2** “Dirty” e-waste plastic shipped off to developing countries.

So how can our industry help with this growing problem? How can we contribute to reducing the number of pounds of ABS plastic that end up in landfills, incinerated, or exported to other countries? The solutions have to be sustainable and economical. Could our industry deal with this in an economical manner?

The development of retroreflective sheeting in the 1940s changed the face of traffic signs forever. Aluminum substrate became the standard for signing. Over 500,000,000 ft<sup>2</sup> of retroreflective sheeting is sold annually in the United States. There are approximately 11 million stop signs replaced in the United States annually. Recycled ABS plastic sheeting can be a reasonable substitute for aluminum substrates for traffic signing (Figure 3).

Recent advances in recycling technology allow for the recycling of e-waste ABS plastic into sheeting. A significant amount of testing has been conducted on ABS recycled plastic sheeting to support the possibility for use as a traffic sign substrate (Figure 4). There are ABS sheeting products available to the market which have been shown to have a flexural modulus of 2,384.4 MPa with a unit weight of 10.54 kN/m<sup>3</sup> and a modulus of elasticity of 2,353 MPa. In addition, many of the market manufacturers of retroreflective sheeting, including Nippon Carbide, Avery Dennison, and 3M, have issued letters extending their warranties to specific ABS plastic sheeting.

The benefits to utilizing recycled ABS plastic sheeting versus aluminum as a traffic sign substrate are numerous. To begin with ABS recycled plastic has almost no after-market value. Or it should be stated it has significantly less after-market value than aluminum. Therefore, recycled ABS plastic sheeting would be far less theft prone than the current aluminum signs. Recycled ABS plastic sheeting is also approximately 35% less expensive than aluminum. Furthermore, some companies actually offer to recycle the ABS sheeting signs at the end of the sign’s life cycle. This reverse logistics helps to reduce the costs to a municipality’s budget as there is usually a discount for such exchanges.

Recycled ABS plastic has advantages when compared to virgin plastic substrates, cost being the biggest. The average cost savings for recycled ABS plastic sheeting is even greater than the savings versus aluminum. One problem with virgin plastics is the outgassing that occurs. Outgassing, apart from being harmful, can also be a problem with respect to the longevity of the retroreflective sheeting. Recycled ABS plastic has minimal or no outgassing so the retroreflective sheeting is not negatively impacted.





**FIGURE 3** Recycled postconsumer ABS plastic sheeting.



**FIGURE 4** Stop sign manufactured with recycled ABS plastic.

The final and possibly most important reason to use recycled ABS plastic sheeting as a substitute for aluminum substrates is the carbon footprint (Figure 5). A recent life-cycle analysis study published in the *International Journal of Environmental Engineering* shows that recycled ABS plastic sheeting has one quarter the carbon footprint as aluminum. It may be possible for some municipalities, which are under mandates to reduce their carbon footprints, to use that study as support for such mandates.

So what is needed is a realistic examination of recycled ABS plastic and its potential use as traffic signing substrate. Conducting an independent study of recycled ABS plastic sheeting



**FIGURE 5** Thermoformed ABS plastic sheet.

could be the basis for the development of a standard, specification, or recommendation. Standardizing recycled ABS plastic sheeting will allow road authorities to utilize recycled ABS plastic sheeting for their signing needs with the knowledge that their sign products are of a specific quality and they will have specific expectations from that quality.

## REFERENCES

1. Basel Conference Addresses Electronic Wastes Challenge. Press release. United Nations Environment Programme, November 27, 2006. Available at: <http://www.unep.org/Documents.Multilingual/Default.asp?DocumentID=485&ArticleID=5431&l=en>.
2. Urgent Need to Prepare Developing Countries for Surge in e-Wastes. Press release. United Nations Environment Programme, February 22, 2010. Available at: <http://www.unep.org/Documents.Multilingual/Default.asp?DocumentID=612&ArticleID=6471>.
3. Exporting Harm: The High Tech Trashing of Asia, Basal Action Network, 2002.



## SESSION 4: NEW ROAD SAFETY PRODUCTS

### **Very High-Precision Weigh-in-Motion Concept Based on Optical Fiber Technology**

**MICHELE ARTURO CAPONERO**

*Italian National Agency for New Technologies, Energy and Sustainable Economic Development*

**ANDREA (ANDREAS) DEMOZZI**

*IRIS Laboratory SRL and iWIM SRL*

**W**ith public and privately funded research and development programs, expertise has been achieved in planning, installing, and operating monitoring systems based on optical fiber sensors and dedicated to structural health monitoring of civil and mechanical engineering infrastructures. New applications and tests have been developed for real-time weight monitoring of passing vehicles.

#### **PREMISE**

The need to identify the overloading by heavy trucks is recognized throughout Europe as a serious problem. For instance, the following directive is cited:

DIRECTIVE 2006/38/EC OF THE EUROPEAN PARLIAMENT AND OF THE COUNCIL of 17 May 2006 amending Directive 1999/62/EC on the charging of heavy goods vehicles for the use of certain infrastructures.

Overloading causes many different consequences, including

- Additional road maintenance costs (due to the excessive wear and damage to roads, bridges and pavements);
- Unfair competition;
- Negative impacts on road safety, e.g., overloading;
- Makes the vehicle less stable, difficult to steer, and takes longer to stop;
- Puts massive strain on vehicle tires and can cause the tires to overheat and wear rapidly (which increases the chance of premature, dangerous, and expensive failure);
- Increases fuel consumption, which will increase costs and pollutions; and
- Uselessness of investment in roadside barriers, because such systems are designed for totally different loads.

A fairer system of charging for the use of road infrastructure, based on the ‘user pays’ principle and the ability to apply the ‘polluter pays’ principle, for instance through the variation of tolls to take account of the environmental performance of vehicles, is crucial in order to encourage sustainable transport in the Community.

(From Directive 2006/38/EC)

Weigh-in-motion (WIM) systems are under development with this aim.

### **FIBER BRAGG GRATING SENSORS TECHNOLOGY: A RELIABLE DEVICE FOR DEVELOPING MONITORING SYSTEMS**

Fiber Bragg grating (FBG) sensors are optical fiber strain gauges. An FBG sensor is embedded in the body of an optical fiber and does not modify neither its dimensions nor its mechanical features. Inside the optical fiber, the FBG sensor is in a short segment about 5 mm long. This segment, attached to the structure to be monitored, allows measuring the deformations of the structure itself. The small size of the FBG sensor makes the deformation measurement to be referred to the “point” of the structure where the sensor is attached. Should be required to measure the deformation in many points, many FBG sensors can be used, each of them attached in one of the points of concern. In such a configuration, all the FBG sensors can be embedded in the body of one single optical fiber at any reciprocal distance (from a few centimeters up to many kilometers). FBG sensors are intrinsic optical fiber sensors and to be operated, no energy is required apart from the light propagating along the optical fiber and to transmit a signal no cabling is required apart from the optical fiber in which they are embedded. FBG sensors provide strain measurement within a dynamic range from 0 Hz up to tens of kHz, thus allowing their use not only for static deformation monitoring, but also for dynamic deformation and vibration modal monitoring (possibility to replace accelerometers). FBG sensors offer many advantages compared to the traditional strain sensors (electrical): intrinsic long-term stability (permanent monitoring of structures for early detection of structural damage), immunity to electromagnetic noise (structural monitoring close to power lines), easy cabling (up to hundreds of FBG sensors can be embedded in one optical fiber), and hardness to hostile environment (intrinsic chemical stability of glass).

FBG sensors intrinsically are strain sensors, but they can be used for various physical and chemical measurements: pressure, mass, humidity, temperature, displacement, and acceleration, etc. In fact, it is possible to correlate the strain measurement to the parameter of concern by placing an FBG sensor in a specifically developed housing. For example, thermal deformation on a metallic beam can be easily correlated to its temperature and thus to the temperature of the environment in which it is placed. Using specific housing, FBG sensors can also be turned from short-gauge (5-mm) strain sensors to long-gauge (up to several meters) strain sensors; a conceptual example of this housing is an elastic beam, pre-stressed and with its ends clamped at the required distance. FBG sensors provide an effective solution for permanent structural health monitoring and maintenance planning of large and remote infrastructures. According to the requirements of the application, FBG sensors can be applied by the most suitable technique (embedding, on-surface sticking, etc.) and with the required spatial distribution (a few sensors very close to each other on a mechanical joint; hundreds of sensors far away one from another along an oil pipe). Any problems related to cabling the FBG sensors to the acquisition device can be solved easily thanks to the high variety of reliable solutions already developed for telecom applications (fire-rodents-water protection and suspended or submarine cables). Moreover, low energy consumption of FBG systems allows remote operation of the FBG control unit and digital (wireless) data transmission.

## **INNOVATIVE APPLICATION OF FBG SENSORS TECHNOLOGY: WEIGHING OF PASSING VEHICLES**

The characteristics of the FBG sensors make this technology an amazing tool for a new concept of WIM system. In brief, this is a system with the following aspects:

- Fiber-optic sensor;
- No electricity line (it is enough to use a local little photovoltaic module);
- Very high precision (picometric level);
- No influences from magnetic fields; and
- Weatherability, i.e., no influences from the aggressive chemical environment typical of roads (corrosion by antifreezing salts, acid rains, or air pollution).

Therefore, WIM research is aimed at developing a prototype with very high performance in heavy vehicle monitoring and managing. The system will allow the real-time and high-precision monitoring of weight, speed, and length of passing vehicles on a road section.

The main targets of this information are

- Direct real-time check of any overloaded truck by the police; and
- Modulation of the toll system on the real weight of the vehicle (a fair principle is “the more you weigh, the more you damage the road structure, the more you pay”).

WIM systems based on FBG technology have garnered great interest for many years and different solutions have been tested. For example, the EU WAVE (WIM of axles and vehicles for Europe) Project is cited.

However, today a widespread commercial product with such a technology does not exist, nor it is going to be spread (may be due to both the intrinsic difficulty in the required precision and the rigid market of the traditional technologies).

A new idea has been developed by the Italian National Agency for New Technologies, Energy and Sustainable Economic Development: to measure the WIM through the energy dissipation during the deformation instead of the deformation measurement itself.

## **PROGRAM OF LABORATORY TESTS**

Many laboratory tests are scheduled, including:

- First comparison between FBG sensors and traditional piezoelectric sensors;
- Indoor real-scale tests, with low speed and low weight;
- Outdoor real-scale tests, with speed and weight as in real applications; and
- On-site installation (Brenner Motorway), with permanent monitoring and check of the performances.

## Comparison of FBG and Piezoelectric Sensors

Many measurements have been done with different weights, using last-generation piezoelectric sensors (micro-measurements technology). The results have been compared with those obtained from FBG sensors technology (Figures 1 and 2).

The scattering of the FBG system peak values (blue spots) has been verified as much lower than the scattering that comes from the piezoelectric one (red spots) (Figures 3 and 4).

The excellent results convinced us to continue the experiments immediately on a larger scale (Figure 5). Therefore, new tests have been already carried out, with different cars and different velocities.

## Indoor Real-Scale Tests with Low Speed and Low Weight

A very high precision in weighing has been verified with standard deviations in the order of thousandths.

With such results, a FEM model of the system has been validated, so future studies will be developed also by calculation (Figures 6 and 7).

Furthermore, full-scale tests are scheduled within September 2012, with heavy trucks and high speeds.

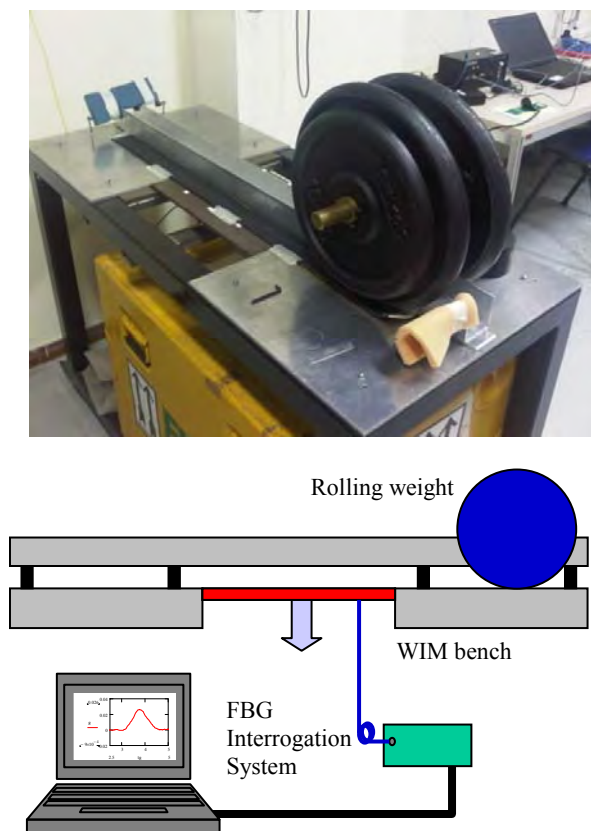

**FIGURE 1** Experiment set-up for tests done on bench laboratory.

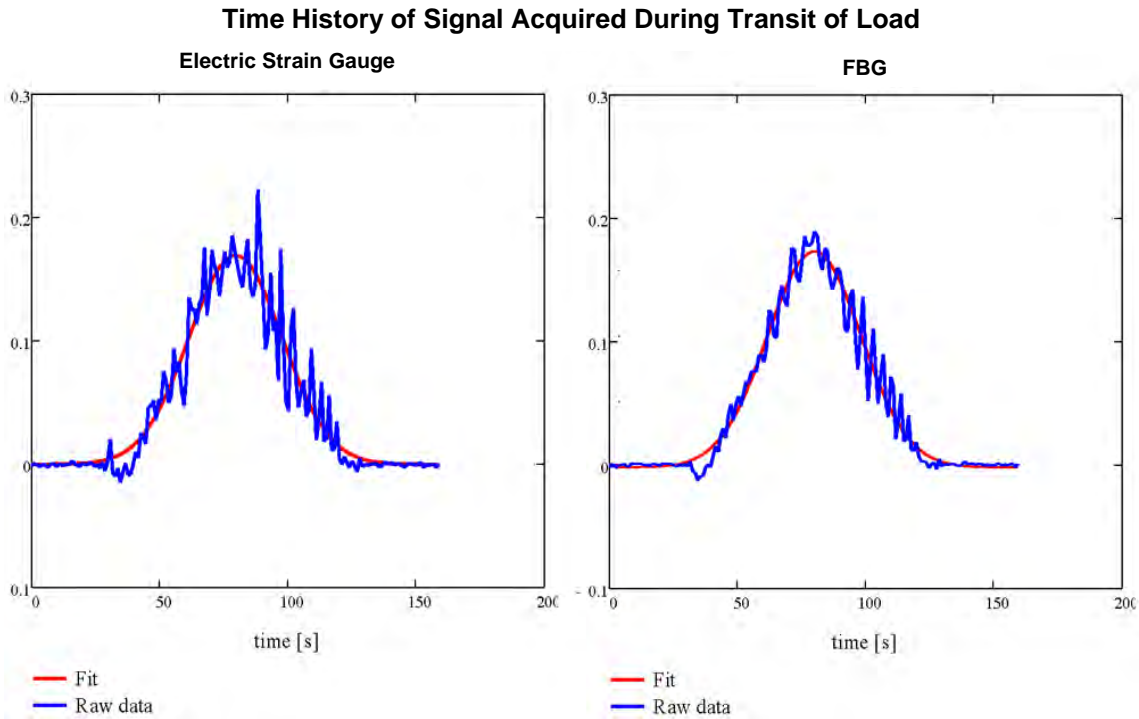

**FIGURE 2 Comparison between data acquired by electric strain gauge sensors and by FBG sensors.**

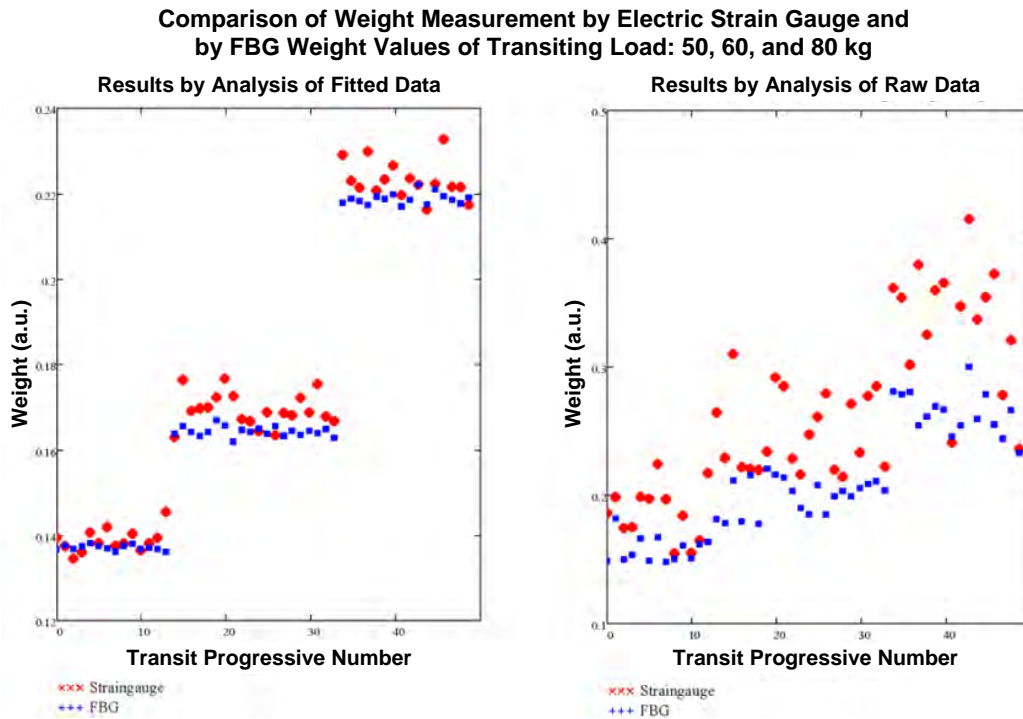

**FIGURE 3 Evidence of the improvement of the dispersion that can be obtained working out the weight by analysis of fitted data instead of analysis of raw data.**



**FIGURE 4** Experimental set-up for indoor WIM test at slow speed. Drawing on right shows dependence of sensors on position of transiting load: signals in red (blue) refer to load transiting on Sensor S1 (Sensor S3).

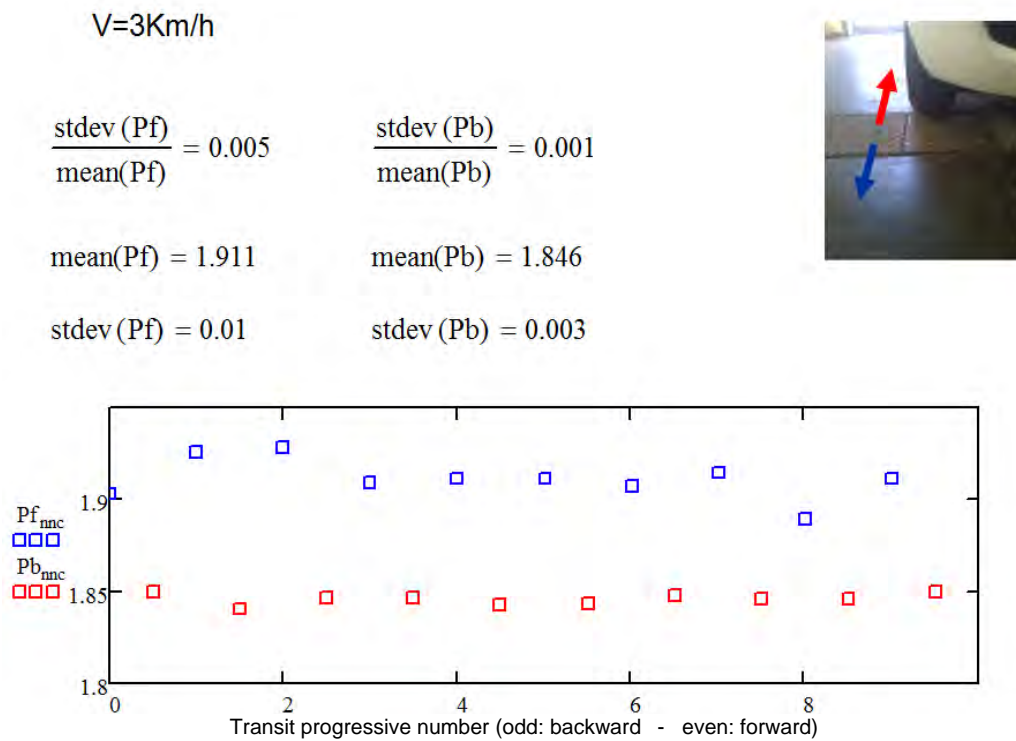

**FIGURE 5** Results of test at slow speed (3 km/h) with back-and-forth transit of front wheel on the WIM bending plate: Pf, forward, blue data; Pb, backward, red data. Weight values are given in arbitrary units. Results show evidence of different weight measurement for the dynamic load of the front wheel (picture, right) transiting forward and backward, as expected from shock absorber with  $acc \neq 0$  motion.



## FEM Numerical Evaluation of Bending Plate Deformation: Transit at Midspan

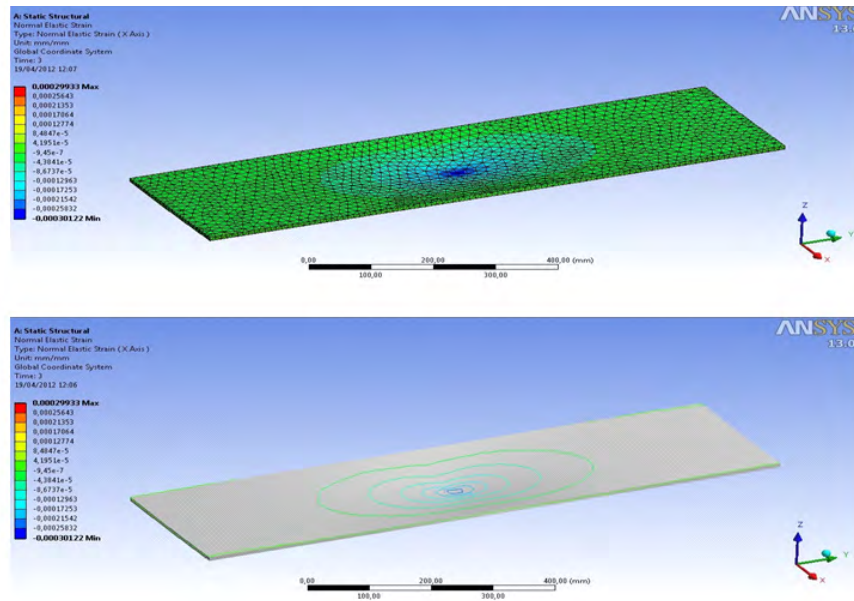

**FIGURE 6** FEM numerical evaluation of the deformation of the bending plate in correspondence of load applied at the centre of the plate: (*top*) FEM mesh in deformed condition and (*bottom*) contouring of deformed condition.

## FEM Numerical Evaluation of Bending Plate Deformation: Transit Out of Midspan

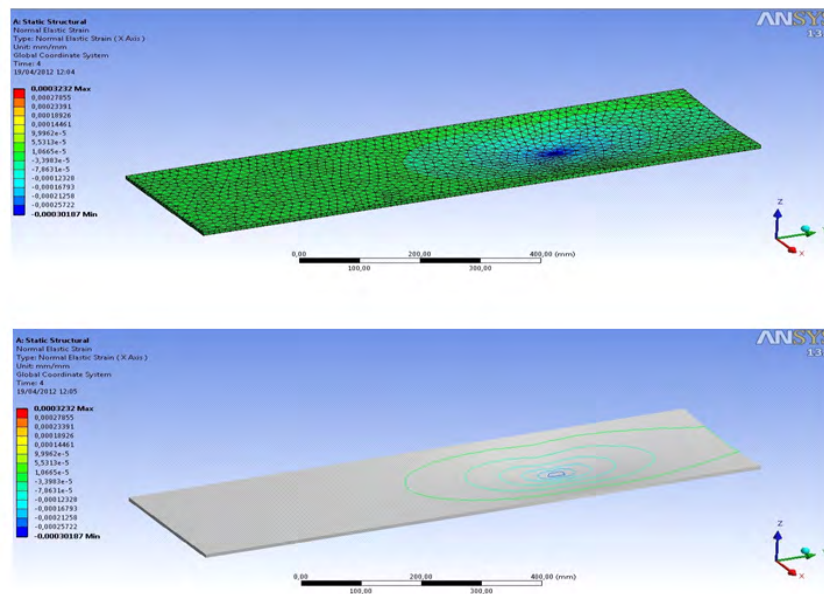

**FIGURE 7** FEM numerical evaluation of the deformation of the bending plate in correspondence of load applied out of the centre of the plate: (*top*) FEM mesh in deformed condition and (*bottom*) contouring of deformed condition.

## SESSION 4: NEW ROAD SAFETY PRODUCTS

**The ABCs of Truck-Mounted Attenuators****MIKE DREZNES***International Road Federation*

**T**oo often, motorists do not see the warning signs in a work zone or do not realize that a truck in a work zone is stopped or moving very slowly. These motorists impact the rear of these work zone vehicles and the results can be catastrophic. The basic purpose for a truck-mounted attenuator (TMA) is to reduce the severity of impacts by errant vehicles into these trucks being used in work zones.

TMA's have been in use since the 1960s and more than 50,000 units are in use. In effect, a TMA is a crash cushion that is either attached to the rear of a truck or pulled behind the truck as a trailer (**Figure 1**). TMA's can be used on barrier vehicles, which are work vehicles that are stopped in a work zone to shield workers or equipment in front of the truck, or on shadow vehicles, which are work vehicles that are moving slowly behind other vehicles that are performing maintenance functions.

TMA's use the same energy-absorbing principles as stationary crash cushions. They evenly and gradually dissipate the kinetic energy of impacting vehicles to reduce the severity of the impacts. They also prevent impacting vehicles from underriding a barrier vehicle or a shadow vehicle. TMA's extend the time of the event, thereby reducing deceleration levels on the occupants.



**FIGURE 1** Example of a TMA.

TMAs protect the motorist, the driver of the work vehicle, and the work vehicle itself. Most contractors typically are more concerned with their vehicles and the drivers of their vehicles than they are the motorists. It is the responsibility of the road authority to mandate the use of TMAs to protect their motorists in and around work zones. Contractors will use TMAs if told to do so. However, very few contractors are concerned enough with motorists' safety to use a safety feature that may make them uncompetitive in the bidding process for a job. Contractors insist that they play on a level playing field, and if every contractor is required to use a TMA, then they will all use TMAs.

One common misconception regarding TMAs is "rollahead." Rollahead is defined as the distance a vehicle will displace when impacted. The amount of this rollahead is dependent on the weight and speed of the work zone vehicle, the weight and speed of the impacting vehicle, the angle of impact, and pavement conditions. TMAs have minimal, if any, effect on the rollahead distance. If TMAs do anything, they can slightly reduce the amount of rollahead due to the added weight on the impacted vehicle. Rollahead must be considered whether a TMA is used or not to ensure trucks are safely positioned in a work zone and do not become a hazard for workers in front of them if they are impacted. Charts are available that define recommended rollahead distances and they should always be used.

*NCHRP Report 230: Recommended Procedures for the Safety Performance Evaluation of Highway Appurtenances*, *NCHRP 350: Recommended Procedures for the Safety Performance Evaluation of Highway Features*, and AASHTO's *Manual for Assessing Safety Hardware* (MASH) have outlined specific testing requirements for TMAs. The United Kingdom has its own testing criteria for TMAs and the European Community is working on criteria for TMA testing that should be completed and implemented in 2013, if not before.

TMAs are mandated in most states in the United States as well as the United Kingdom, Belgium, Netherlands, Norway, Sweden, Denmark, Australia, and New Zealand for selected work zone applications. TMAs are extremely effective when used to shield shadow vehicles, since few other options for protection are available. The *Manual on Uniform Traffic Control Devices* in the United States recommends, but does not require the use of TMAs.

## SESSION 4: NEW ROAD SAFETY PRODUCTS

## Importance of an Appropriate Transition in a Longitudinal Barrier Design

**MIKE DREZNES**

*International Road Federation*

**L**ongitudinal barriers can be classified in three categories based on their lateral deflection when impacted on an angle by an errant vehicle. These categories are rigid, semi-rigid (semi-yielding), and flexible (yielding). When two of these barriers are joined to each other, such as a rigid bridge rail and a semi-rigid W-beam guardrail, a transition must be used to compensate for the differences in the lateral stiffness to allow the continuous longitudinal barrier to redirect the vehicle smoothly and safely.

A transition is defined as a section of barrier used to produce the gradual stiffening of a flexible or semi-rigid barrier as it connects to a more rigid barrier or fixed object. Crash tests have shown that if a transition is not used an errant motorist that impacts the semi-rigid or flexible barrier on an angle could be snagged or be redirected into the blunt end of the rigid barrier. This is commonly referred to as pocketing. A properly configured and installed transition is designed to shield these unprotected ends of rigid barriers because they are hazards. These transitions should provide an effective transition between longitudinal barriers with different lateral stiffness and redirect impacting vehicles without any contact with the rigid barrier.

Stiffer transitions can be accomplished through the use of additional posts with reduced post spacing, larger posts, doubled (nested) rail elements, rubrails, and other special features such as use of a stiffer semi-rigid barrier such as a thrie-beam barrier. Transitions typically are generic designs.

*NCHRP 350: Recommended Procedures for the Safety Performance Evaluation of Highway Features*, *AASHTO's Manual for Assessing Safety Hardware*, and European Normative (EN) 1317-4 have outlined testing requirements for transitions. Many of these transitions are generic and have been required in the United States since 1993. Few European countries require the use of these transitions. However, this is expected to be addressed in the near future as EN 1317-4 becomes finalized and goes into effect.

EN 1317-4 is under formal enquiry. It is expected that Part 4 will include different levels of assessment. Level A1 will require three tests. Two of the tests will be TB11 tests: one upstream of the transition, and the other in the span of the transition. The third test shall be a containment test with the impact point upstream of the transition.

Level A2 will require two tests. One test will be the TB11 test and the other test will be the containment test. The impact location will be determined by the use of computational mechanics.

Level B1 will require one TB11 test and one containment test.

For Level B2, the transition shall be evaluated with two simulated vehicle impact tests. Test approaches are the same as in level B1.

Level B3 will be connections between two members of the same barrier family with design requirements and Level C will only require design requirements.

## SESSION 4: NEW ROAD SAFETY PRODUCTS

## Consideration of Wood Mechanical Properties Variation in Roadside Safety Barriers Performance Evaluation

CLÉMENT GOUBEL

*INRETS Road Equipment Test Laboratory, France*

The use of finite elements (FE) models in roadside safety research is now largely adopted. The capability of these models to reproduce with accuracy real crashes has been illustrated and, more and more, one can call on FE analysis to design new devices, to understand the behavior of existing ones, or to predict the behavior in several conditions. In most of the cases a simulation is compared to a real crash test results in order to validate the model.

A vehicle restraint system (VRS) evaluated in the frame of the European Normative (EN) 1317 is classified in two different ways:

- A severity class which depends on the results obtained for two severity indices: Accident Severity Index (ASI) and Theoretical Head Impact Velocity (THIV) and
- A working width (W) class which is directly linked to the working width measurement.

### MODEL VALIDATION BASED ON FAILURE MODES ANALYSIS

In a crash of a vehicle against a VRS, a lot of parameters could have an effect on the global behavior and, thus, to the severity indices and W results. As the structures are highly solicited (for some component until the failure) the use of standardized data for parameters such as steel yield point could lead to poor correlation. Furthermore, even if the components are checked after the crash, uncertainties concerning the real component mechanical properties are remaining.

When talking about correlation between a simulation and a real test in the field of roadside safety, it is frequent to see comparison between one crash configuration (mainly due to the crash test cost) and one simulation. This point-to-point comparison is unfortunately very poor, as the variation of mechanical properties is quite important and can affect significantly the device performances. One important issue of this paper is to outline a procedure for assessing the intrinsic variability of a VRS and then to compare an experimental result to a cloud of numerical simulations.

LIER procedure is based on the failure modes analysis. A failure mode is defined by a sequence of events which activates a mechanism in the device.

**Figure 1** presents the test sequence of one TB32 simulation performed on a VRS which is made of C100 steel posts every 2 m and a wooden beam with a steel reinforcement connected to the post with a steel spacer.



The analysis of this test sequence leads to the identification of four main mechanisms listed in **Table 1**.

The failure modes observed during real test can be clearly illustrated thanks to numerical tools. Table 1 shows the main sequence that is repeated at every post of the device until the

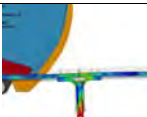

**FIGURE 1** Test sequence from one TB32 simulation.

**TABLE 1** Four Main Mechanisms

Failure Mode	Component	Main Parameter	Average Value	Range of Variation
 Post plastic hinge	Post	Steel yield stress	270 MPa	240–300 MPa
 Articulation plastic deformation	Spacer and reinforcement	Steel yield stress	270 MPa	240–300 MPa
 Bolt failure	Bolt	Beam failure force	37,950 N	33,700–42,200 N

effectiveness of the redirection of the vehicle. For each failure mode identified, the physical parameter which could affect the apparition of the failure mode is added to the table.

For each parameter, three values are considered: a minimum, average, and maximum value taken from LIER experience in the field of material analysis. This leads, in a full factorial Design of Experiment (DOE), of  $3^3 = 27$  simulations ran with LS-DYNA explicit solver.

## RESULTS

The results are presented in [Figure 2](#). The tolerances proposed by the CM-E group are identified by the red rectangle. All the simulations are in accordance with EN 1317 criteria remaining in severity class A ( $ASI \leq 1.0$  and  $THIV \leq 33$  km/h). The results obtained vary between two working



width class (W5 and W6, real test standing in the border of W5 class) but with a 5% variation which is reasonable compared to  $\pm 10\%$  of variation of the design variables of the DOE. These results highlight the robustness of the device.

Furthermore, it's worth noticing that the chosen DOE enclose the experimental result in terms of ASI and W very well.

Figures 3 and 4 illustrate the best correlation test–simulation for velocity components of the vehicle's center of gravity in the global reference frame obtained for the shot 18 in which the set of parameter leads to the full validation of the numerical model according to CM-E requirements.

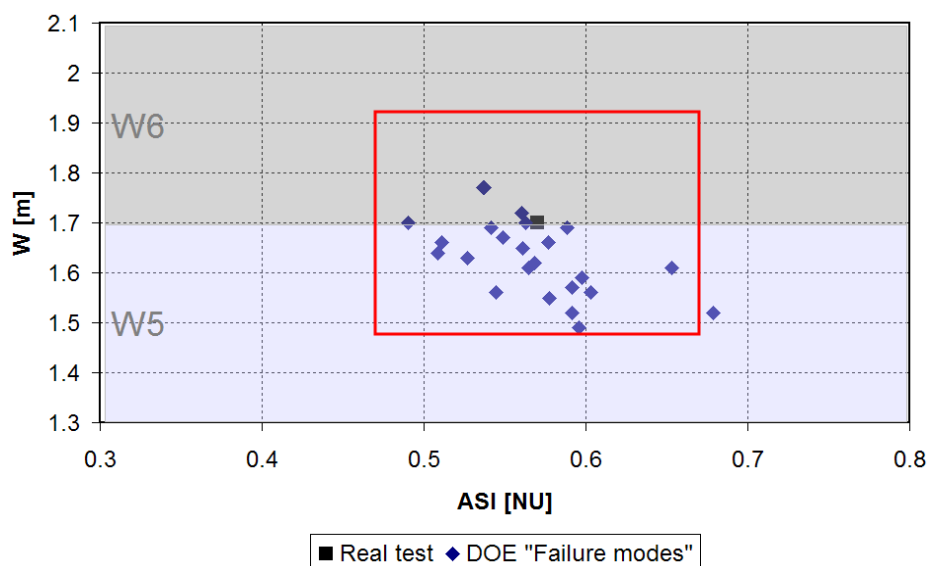

**FIGURE 2 EN 1317 results from failure modes simulations and full-scale test.**

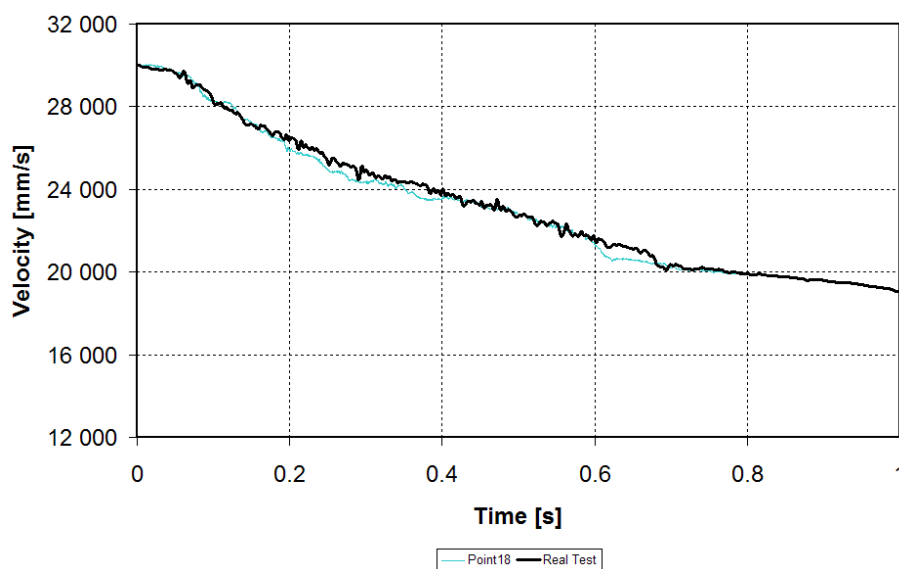

**FIGURE 3 X velocity component time plot for a simulation and full-scale test.**

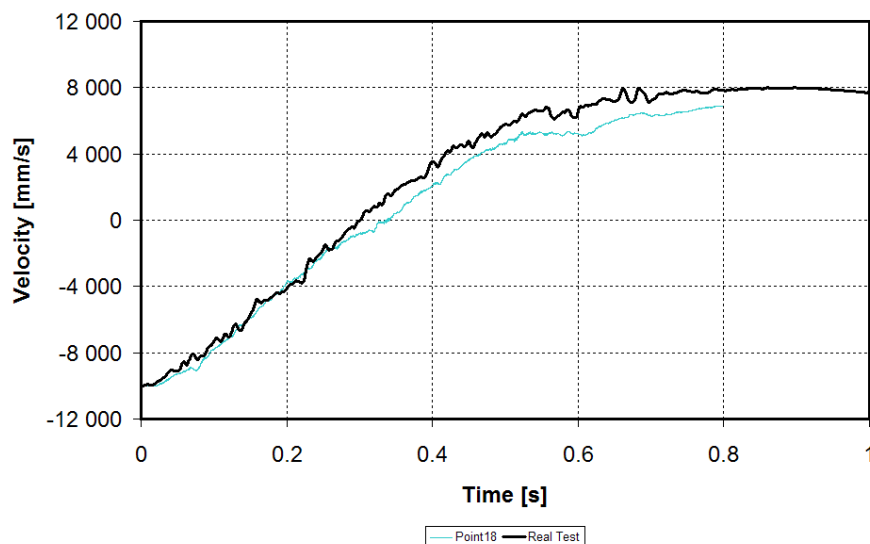

**FIGURE 4** Y velocity component time plot for a simulation and full-scale test.

## ASSESSMENT OF WOOD MECHANICAL PROPERTIES VARIATION EFFECT

Since the numerical model is validated following CEN-TC226-WG1-TG1-CM-E recommendations, a new parametric study is defined to assess the effect of wood mechanical properties variation (Figures 5 through 7).

The LS-DYNA wood material (type 143 available in LS-DYNA), developed under contract from the FHWA offers the opportunity to use four moisture contents and four temperatures which lead to 16 possibilities affecting both elastic and failure properties of the wood material.

Our interest is that default material properties for yellow pine are available and temperature (T) and moisture content (MC) could be changed (0°C, 10°C, 20°C, and 30°C and 0%, 10%, 20%, and 30%, respectively) for three grades of wood quality.

In order to enhance the accuracy of this material law and to find out the set of parameters that best fits the wood characteristics used in Europe, experimental three-point-bending dynamic tests were carried out. Those tests were performed at three velocity levels on some samples of a road safety barrier. Two kinds of structures were tested, with and without steel reinforcement.

This allows, in the validation process of the numerical model, to distinguish the wood and the steel-wood modeling problems. The results of this work was published and allowed to validate the wood material law in the corresponding test conditions ( $20\% < MC < 30\%$  and  $20^{\circ}\text{C} < T < 30^{\circ}\text{C}$ ).

A complete factorial DOE was defined to assess the effect of wood mechanical properties variation (16 combinations).

Although the mechanical properties variation due to Moisture Content and Temperature variation is very high, the variation of EN 1317 severity indices (ASI and THIV) remains around 3%.

The main effect is on W results because of wood beams failure that occurs in almost all simulations performed below 10°C and below 10% of MC. This failure is clearly due to a more brittle behavior of the wood material for these test conditions parameters which has not been validated.

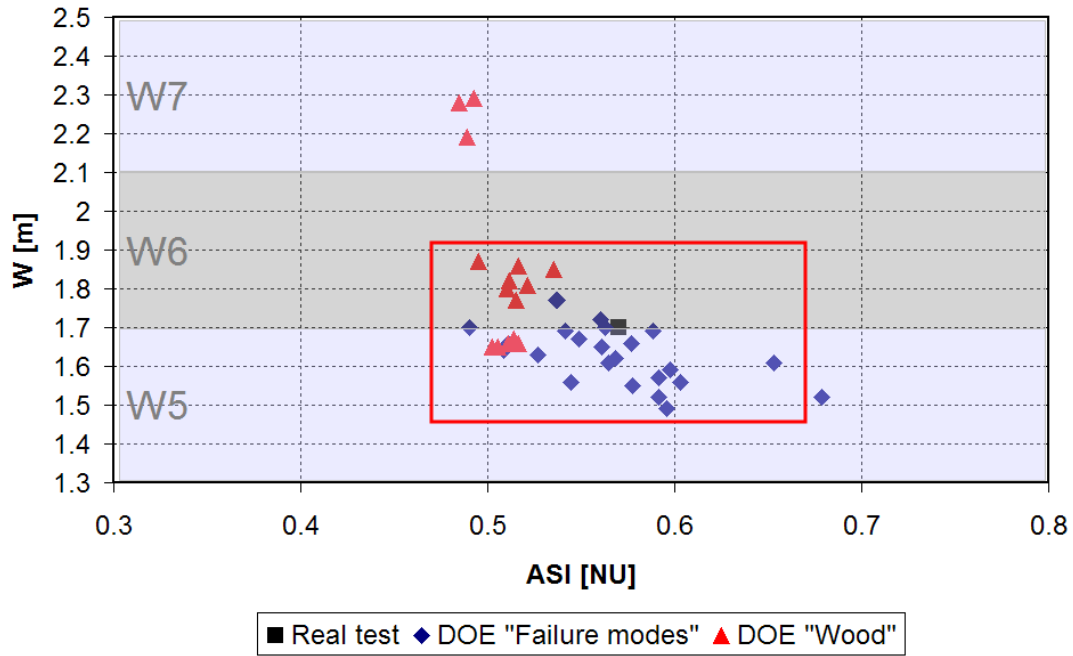

**FIGURE 5 Failure modes for the wood material.**

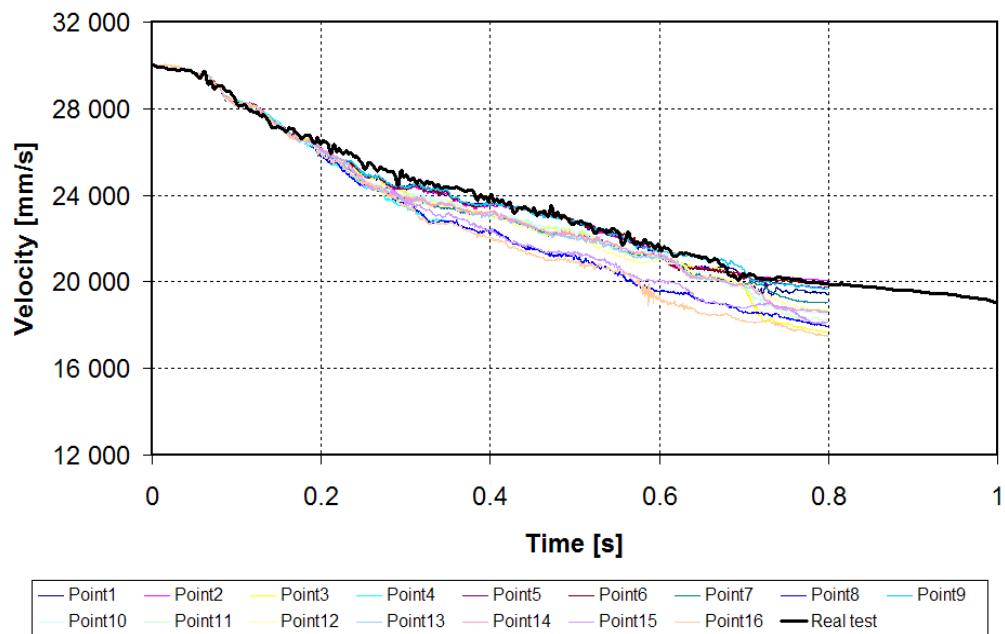

**FIGURE 6 X velocity component plots for wood variability and real test.**

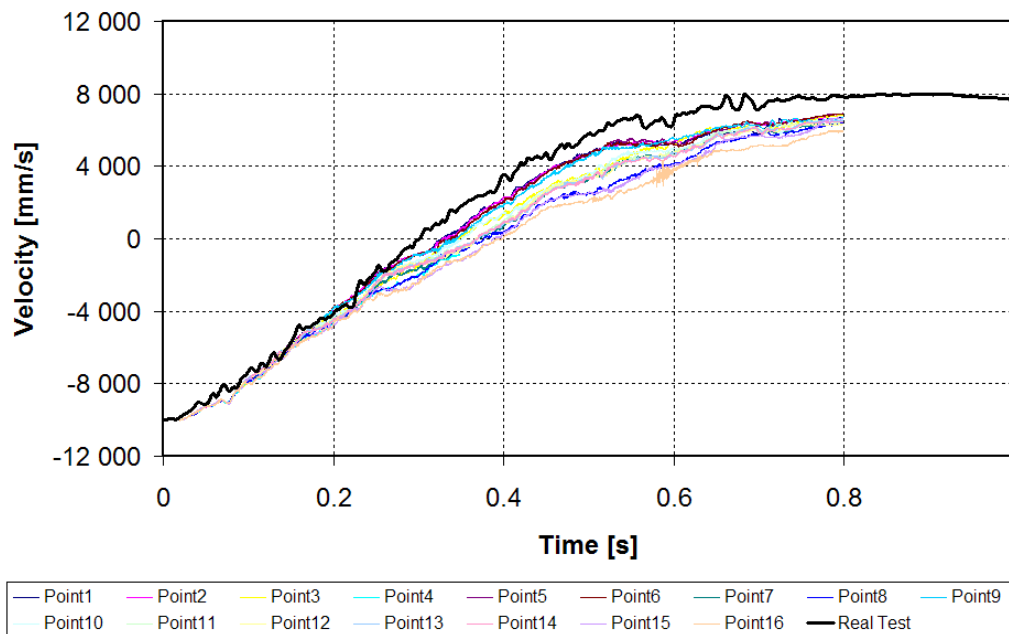

**FIGURE 7** Y velocity component plots for wood variability and real test.

In terms of velocity components, the figures show the corridors obtained in the global reference frame are narrower than those obtained in the failure modes DOE. This fact brings to the conclusion that the wood, in this specific design, does not enter in the failures modes of the structure.

The environment (mainly temperature and moisture content) affects wood mechanical properties. This fact has been highlighted in experimental tests and well represented by a numerical study by the mean of a parametric study.

On the roadside, those parameters can vary and cannot be controlled. One interest of a numerical model is to take into account those variations in order to obtain a corridor of responses and, thus, to assess their effect to the VRS performances.

Steel-wood devices are in fashion in places where infrastructures has to be discrete (mountains or countryside). In this paper, the effect of wood mechanical properties variation due to environment variable toward the performances has been illustrated.

The variation of this environment variables proposed in the material law has been applied to a VRS numerical model in a parametric study. The effect of this variation is very limited towards the device performances in terms of severity. For lowest value of MC and T, the brittle behavior of wood leads to failure of some wood beams which only affects deflection measurements without challenging the proper behavior of the VRS under vehicle impact. Thus, steel-wood devices, characterized by good severity indices, should not be considered only environmentally friendly but also safe.

## Workshop Outcomes and Concluding Remarks

In 1987, the chairs of the Committee on Roadside Safety Design recruited eight members to start an International Research Activities Subcommittee. In a corporate hospitality suite at the 66th Annual Meeting of the Transportation Research Board in 1987, these eight individuals, one from Sweden, one from Germany, one from Italy, one from France, and four from the United States, created an organization that today is one of the most active and effective subcommittees at TRB.

Today the International Research Activities Subcommittee boasts a membership that includes more than 120 members and more than 250 friends from more than 33 countries around the world. This subcommittee continues to increase the visibility of TRB globally. Subcommittee members and friends work hard to implement the policies and procedures that will make the roadsides safer in every country in the world.

The meeting in Milan was no exception. At the end of the day, the attendees agreed that the European meeting in Milan was most successful and that there is a need to conduct a similar meeting in Europe on a regular basis.

Those eight men who met that winter day at the 66th Annual Meeting in 1987 must be smiling with the satisfied smile of a job well done.

A list of attendees is provided in Appendix B.

*—Rod Troutbeck and Mike Dreznes  
Cochairs, International Research Subcommittee of Roadside Safety Design Committee  
August 2012*





# Appendices



APPENDIX A

**2012 European Workshop on Roadside Safety Design**  
*Agenda*

**ROD TROUTBECK**  
**MICHAEL DREZNES**  
*Cochairs*

- 9:00 a.m.      Opening Remarks, *Rod Troutbeck and Michael Dreznes*  
Self-Introductions, *Michael Dreznes*  
Membership Status, *Rod Troutbeck*
- 9:20 a.m.      **Session 1: Assessment Practices**  
*Chair: Rod Troutbeck, Troutbeck Associates, Australia*
- NCHRP 350 Compared to MASH  
*Mike Dreznes, International Road Federation*
- Can EN 1317 and NCHRP 350–MASH Be Used Interchangeably?  
*Jason Hubbell, Atlanticum Bridge Corp, Italy*
- Current Status of EN 1317: U.S.–Europe Test Result Mutual Recognition  
*Marco Anghileri, Politecnico di Milano, Italy*
- EN 1317 and CE Marking Versus National Regulations  
*Franz M. Muller, Road Safety Consultant, Italy*
- Latest Update to the British Vehicle Restraint Assessment Process  
*Martin Heath, MHA Planning and Transport, United Kingdom*
- 11:00 a.m.      **Session 2: Safe Systems**  
*Chair: Marco Anghileri, Politecnico di Milano, Italy*
- Introduction (or Reintroduction) to the Safe System Approach  
*Raphael Grzebieta, Transport & Road Safety Research, UNSW, Australia*
- Real-World Implications of the Safe System Approach  
*J. Marten Hiekmann, PASS CO, Germany*

Improving Roadside Design to Forgive Human Errors: Forging Roadside Design Guidelines

*Francesca La Torre, University of Florence, Italy*

END Turned-Down ENDS

*Mike Dreznes, International Road Federation*

END Turned-Down ENDS: How the United Kingdom Accomplished It

*Steve Powell, Highway Care Ltd., United Kingdom*

End Treatments of Safety Barriers: Best Practice and Challenge in Germany: German Experience

*Uwe Ellmers, BASt, Germany*

2:00 p.m.

**Session 3: Best Practices**

*Chairs: Ali Osman Atahan and Mustafa Kemal University, Turkey*

Best Practices and Strategies to Reduce Fatal or Serious Injury Crashes into Guardrail Posts by Motorcyclists: Spanish Experience

*Angel Martinez, HIASA, Spain*

Best Practices and Strategies to Reduce Fatal or Serious Injury Crashes into Guardrail Posts by Motorcyclists: United Kingdom Experience

*Gavin Williams, TRL, United Kingdom*

Best Practices and Strategies to Reduce Fatal or Serious Injury Crashes into Guardrail Posts by Motorcyclists: Australian Experience

*Raph Grzebieta, NSW Injury Risk Management Research Centre, Australia*

Best Practices and Strategies to Reduce Fatal or Serious Injury Crashes into Obstacles and Road Equipment: Swedish Experience

*Åke Löfqvist, Swedish Transport Administration, Sweden*

Best Practices and Strategies to Reduce Fatal or Serious Injury Crashes into Trees and Posts: German Experience

*Frank Brandt, Volkmann and Rossbach, Germany*

Best Practices and Strategies to Reduce Fatal or Serious Injury Crashes into Posts and Luminaire Supports: United States and Other International Experiences

*Art Dinitz, Transpo Industries*

EN 12767: Passive Safety of Support Structures for Road Equipment

*Carolien Willems, Safety-Product, Belgium*

4:30 p.m.

**Session 4: Other Road Safety Issues***Chair: Gavin Williams, TRL, United Kingdom*

Development of a Redirective Crash Cushion to EN 1317-3

*Luigi Grassia, Second University of Naples, Italy*

Development of N2–H1 Performance Level Guardrail: Crash Testing and Simulation

*Ali Osman Atahan and Mustafa Kemal University, Turkey*

Risks of Unprotected Median Drainage Ditches on Vehicle Stability

*Ali Osman Atahan and Mustafa Kemal University, Turkey*

How High-Friction Surfacing Treatments Combined with Other Safety Hardware Installations Save Lives Globally

*John LeFante, DBI Services*

Development of a Recycled Substrate Material for Road Signs

*Jason Hubbell, Atlanticum Bridge Corp, Italy, and Liz Walker, Image Microsystems*

Very High-Precision Weigh-in-Motion Concept Based on Optical Fiber Technology

*Michele Arturo Caponero and Andreas Demozzi, ENEA National Agency and IRIS Laboratory SRL, Italy*

The ABCs of Truck-Mounted Attenuators

*Mike Dreznes, International Road Federation*

Importance of an Appropriate Transition in a Longitudinal Barrier Design

*Mike Dreznes, International Road Federation*

Consideration of Wood Mechanical Properties Variation in Roadside Safety Barriers Performances Evaluation

*Clément Goubel, INRETS Road Equipment Test Laboratory, France*

7:00 p.m.

**Final Comments and Adjournment***Chair: Mike Dreznes, International Road Federation*

## APPENDIX B

### Workshop Attendees

Felipe Almanza  
TrafFix, USA

Ali Yero Amadou  
Ministère de l'Équipement, Niger

Alberto Andreoni  
Ministero delle Infrastrutture e dei Trasporti  
Italy

Pierre Anelli  
Aximum, France

Marco Anghileri  
Politecnico di Milano, Italy

Fabrizio Apostolo  
*Le Strade* magazine, Italy

Jan Arsoba  
General Directorate for National Roads and  
Motorways, Poland

Patrcik Asimus  
Solosar, France

Ali Osman Atahan  
Mustafa Kemal University, Turkey

Alexander Barnas  
Delta Bloc, Austria

Lorenzo Bartolini  
Spea, Italy

Myrko Bellmann  
Volkman & Roszbach, Germany

Peter Bergendahl  
Trinity Industries, Sweden

Luca Biagini  
Luca Biagini, Italy

Phil Bigley  
Trinity Industries, United Kingdom

Pal Bjur  
Saferoad, Norway

Jean Bloch  
LIER, France

Guido Bonin  
University of Rome la Sapienza, Italy

Steve Bowyer  
Hill & Smith, United Kingdom

Frank Brandt  
Volkman & Roszbach, Germany

Adrian Bullock  
Highway Care, United Kingdom

Marina Casati  
*Le Strade* magazine, Italy

Giulio Catalani  
Consulting Engineer, Italy

Liz Chesworth  
Trinity Industries, United Kingdom

Claudia Cofano  
GD TECH, Belgium

Mauro Corsanici  
AMS srl, Italy

Valeria De Giacomo  
Snoline, Italy

Andrea Demozzi  
IRIS, Italy

Jose Alberto de Prado Rodriguez  
CIDAUT, Spain



Konstandinos Diamandouros  
ERF, Belgium

Art Dinitz  
Transpo Industries, USA

Gerrit Dyke  
Barrier Systems, Inc.

Pape Amadou Diouf  
Ministère des Infrastructures et des Transports  
Senegal

Silvana Disanto  
SNOLINE, Italy

Lorenzo Domenichini  
University of Florence, Italy

Mike Dreznes  
IRF Washington, USA

Jan Droege  
Volkman & Rossbach, Germany

Ben Duncker  
Highway Care, United Kingdom

Ewe Ellmers  
BAST, Germany

Ron Faller  
Midwest Roadside Safety Facility

Luca Felappi  
Arcelor Mittal, Italy

Pedro Fernandes  
VIALITORAL, Portugal

Paola Ferraris  
SNOLINE, Italy

Jeanne Foret  
Aximum, France

Zoubeida Foughali  
Industrias Duero, Spain

Franco Gabbiani  
Prealux, Italy

Marlene Gallien  
Rondino, France

Clement Goubel  
LIER, France

Luigi Grassia  
Second University of Naples, Italy

Lidia Grzebieta  
Professional Engineering Consultants Pty Ltd.  
Australia

Raphael Grzebieta  
Transport and Road Safety  
University of New South Wales, Australia

Martin Heath  
MHA Planning and Transport, United Kingdom

Martin Hiekmann  
PASS CO, Germany

Jason Hubbell  
Atlanticum Bridge Corp, Italy

Pasquale Impero  
AMS srl, Italy

Nikolai Ivanov  
Bulgarian Branch Association for Road Safety ,  
Bulgaria

Juergen Janschitz  
Janschitz gmbh, Austria

Guy Janssen  
GD TECH, Belgium

Ken Konomi  
PMR, Japan

Francesca La Torre  
University of Florence, Italy

John Lefante  
DPI, USA

Filippo Leone  
Magaritelli, Italy

Ake Löfqvist  
Swedish Transport Administration, Sweden

Luciano Marasco  
Ministero delle Infrastrutture e dei Trasporti  
Italy

Joseph Marra  
GD TECH, Belgium

Angel Martinez  
Hiasa, Spain

Rick Mauer  
Gregory Industries

Monica Meocci  
University of Florence, Italy

Eva Minuz  
Atlanticum Bridge Corp, Italy

Fernando Montesinos  
Industrias Duero, Spain

Jacopo Moretti  
Magaritelli, Italy

Michael Mourad  
DPI

Fausto Mozzarelli  
CSI spa, Italy

Franz Müller  
Road Safety Consultant, Italy

Sara Neto  
VIALITORAL, Portugal

Martin Page  
LIER, France

Alberto Pedroni  
Snoline, Italy

Mariano Perneti  
University of Naples, Italy

Andrea Pescatori  
Prealux, Italy

Matteo Pezzucchi  
Norwegian Public Roads Administration  
Norway

Gabriele Piziali  
Prealux, Italy

Steve Powell  
Highway Care, United Kingdom

Willem Prinsloo  
Heintzmann South Africa

Ernst Reijns  
Laura Metal, Netherlands

Davide Riccobono  
SNOLINE, Italy

Christina Rodriguez  
Mieres Tubos, Spain

Armand Rouffaert  
Stuer-Egghe, Belgium

Francesca Russo  
University of Naples, Italy

Sandra Sanchis  
Industrias Duero, Spain

Peter Sandqvist  
VTI, Sweden

Fredrik Sango  
Birsta, Sweden

Daniele Santi  
Fracasso, Italy

Tobias Schneider  
SGGT, Germany

Fadi Tahan  
George Washington University, USA

Novella Tajariol  
D Kougioumtzopoulos, Italy

Oscar Tejedor  
AMS srl, Italy

Jeff Thompson  
Barrier Systems, Inc.

Gavin Williams  
TRL, United Kingdom

Gunther Thuysbaert  
Stuer-Egghe, Belgium

Wolfgang Wink  
Volkman & Rossbach, Germany

Mark Tonks  
Hill & Smith, United Kingdom

Daisy van den Hout  
ANWB, Netherlands

Rod Troutbeck  
Troutbeck Associates, Australia

Richard van den Hout  
ANWB, Netherlands

Karl Urlberger  
SPS-Schutzplanken GmbH, Germany

Hans Verstappen  
Laura Metal, Netherlands

Lennart Wahlund  
RSSE, Sweden

Jus Znidarsic  
Asfalteks, Slovenia

Carolien Willems  
Safety-Product, Belgium



**2012 Roadside Safety Design and Devices International Workshop attendees.**



# THE NATIONAL ACADEMIES

## *Advisers to the Nation on Science, Engineering, and Medicine*

The **National Academy of Sciences** is a private, nonprofit, self-perpetuating society of distinguished scholars engaged in scientific and engineering research, dedicated to the furtherance of science and technology and to their use for the general welfare. On the authority of the charter granted to it by the Congress in 1863, the Academy has a mandate that requires it to advise the federal government on scientific and technical matters. Dr. Ralph J. Cicerone is president of the National Academy of Sciences.

The **National Academy of Engineering** was established in 1964, under the charter of the National Academy of Sciences, as a parallel organization of outstanding engineers. It is autonomous in its administration and in the selection of its members, sharing with the National Academy of Sciences the responsibility for advising the federal government. The National Academy of Engineering also sponsors engineering programs aimed at meeting national needs, encourages education and research, and recognizes the superior achievements of engineers. Dr. Charles M. Vest is president of the National Academy of Engineering.

The **Institute of Medicine** was established in 1970 by the National Academy of Sciences to secure the services of eminent members of appropriate professions in the examination of policy matters pertaining to the health of the public. The Institute acts under the responsibility given to the National Academy of Sciences by its congressional charter to be an adviser to the federal government and, on its own initiative, to identify issues of medical care, research, and education. Dr. Harvey V. Fineberg is president of the Institute of Medicine.

The **National Research Council** was organized by the National Academy of Sciences in 1916 to associate the broad community of science and technology with the Academy's purposes of furthering knowledge and advising the federal government. Functioning in accordance with general policies determined by the Academy, the Council has become the principal operating agency of both the National Academy of Sciences and the National Academy of Engineering in providing services to the government, the public, and the scientific and engineering communities. The Council is administered jointly by both Academies and the Institute of Medicine. Dr. Ralph J. Cicerone and Dr. Charles M. Vest are chair and vice chair, respectively, of the National Research Council.

The **Transportation Research Board** is one of six major divisions of the National Research Council. The mission of the Transportation Research Board is to provide leadership in transportation innovation and progress through research and information exchange, conducted within a setting that is objective, interdisciplinary, and multimodal. The Board's varied activities annually engage about 7,000 engineers, scientists, and other transportation researchers and practitioners from the public and private sectors and academia, all of whom contribute their expertise in the public interest. The program is supported by state transportation departments, federal agencies including the component administrations of the U.S. Department of Transportation, and other organizations and individuals interested in the development of transportation. [www.TRB.org](http://www.TRB.org)

[www.national-academies.org](http://www.national-academies.org)



**TRANSPORTATION RESEARCH BOARD**  
500 Fifth Street, NW  
Washington, DC 20001

## **THE NATIONAL ACADEMIES™**

*Advisers to the Nation on Science, Engineering, and Medicine*

The nation turns to the National Academies—National Academy of Sciences, National Academy of Engineering, Institute of Medicine, and National Research Council—for independent, objective advice on issues that affect people's lives worldwide.

[www.national-academies.org](http://www.national-academies.org)



**NATIONAL ACADEMY OF SCIENCES**

1863–2013 • Celebrating 150 Years of Service to the Nation