



A Tale of Two Suburbs

Gustav Vrang

**Handledare/
Supervisor** Hélène Frichot, Assistant Professor

**Examinator/
Examiner** Anders Johansson

Examensarbete inom arkitektur, avancerad nivå 30 hp
Degree Project in Architecture, Second Level 30 credits

24 maj 2013



A Tale of Two Suburbs

Prologue

A critical comparison of two suburbs in Södertälje, Lina Hage and Glasberga. In Lina, each home owner was allowed to build as they wanted. in Glasberga, a joint venture of municipality and corporations tried to plan according to their vision of the modern suburb and with vernacular ambitions.

What is the role and potential of the Swedish suburb in relation to urban planning procedures today? How can the planning of new Swedish suburbs be expanded so as to offer different alternatives for an increasingly mixed Swedish and migrant population



Lina Hage (kv Murverket)

Södertälje has since way back been a proletarian town ruled by the Social Democrats and "they always built for their people" (Andrén 2008). This meant houses that structurally and programatically followed the ideals of "folkhemmet"; robust pre-fab and rowhouses houses with a restrained amount of ornament and personalization.

In the late 90's, after a shocking shift of power in the municipality, the conservative and liberal parties announced that this would be the dawn for new building policies in town:

"In the late 90's, we set out to reduce the building restrictions for private house in order to stimulate the market. There would be no more house mats like the conventional suburbs in our town - now people were going to be allowed to build as they wished. No damn authority is going to decide what people want to do with their money."
- Bengt Andrén (m), ex. planning manager, 2008

Lina Hage was the pilot project. But instead of houses with different colors and roofing, the area became a plethora of shapes, materials, symbols and lifestyles. As one of

the architects behind the houses puts it: "The areas that are built in Södertälje are unique, there are no other places where you would find something similar in Sweden. I would say that they are the direct result of a good cooperation with the municipality. The town has adapted to its multicultural population and allowed for new traditions. This is brave, and wise. The house owners are allowed to live out their dreams and show who they are."
- Jie Zhao, 2011

Glasberga Sjöstad

The response to Lina Hage was very mixed. Potential home builders saw the freedom of choice as fantastic and the demand for more plots with the same building code exploded.

The home-owners organization (Villaägarna) were appauled and saw the development as a downhill slope that would make Södertälje a place were no-one would want to live. The focus was quickly turned to Glasberga Sjöstad, a major suburb on the Stockholm-side of town on the fields of an old manor. The project had been a buzz for many years but just recently gone into serious planning

procedures. The authors behind Glasberga was a joint venture made up of JM, Riksbyggen, Telgebostäder and the town of Södertälje. Once completed, it will be place for almost 600 new homes.

The Master Plan was set with a long list of restrictions and was appended with a Design document that explained the ambitions and ideals that would characterize the new suburb. The outspoken idea was to make it a garden-city based on local building traditions

and virtues such as "beautiful Swedsh simplicity"

Until now only about 75 plot have been exploited and many of these houses are from catalogues. But there is also some recent examples that have traits from Lina Hage and this has caused much conflict. Almost to the point where the entire project will be cancelled.

Chapter 1

Södertälje's Population Development and the Urban Texture that Followed

In 1900, Södertälje was a flourishing and exclusive bath resort for persons of wealth searching for a week or two of relaxation and comfort.

A few years later started the industrial boom, fueled by the closeness to Stockholm and the direct access to the Baltic Sea. This was spearheaded by the emerging businesses Astra and Scania and workers arrived in great numbers both from Sweden and abroad, mostly Finland, Greece, Italy and former Yugoslavia. The building industry was working at full throttle.

This development climaxed in the "record years" of 1965-75 represented by the million programme and a re-development of the town centre. This thoroughly re-invented Södertälje as the definitive worker's town it is today.

The oil crisis led to an almost complete development stop. The town would have imploded if not a wave of Assyrian/Syriac immigrants filled the apartments where truck mechanics or medical technicians were thought to move in.

The development up to now had been focused on apartment buildings. Lina Hage and Glasberga Sjöstad are examples of the later years shift to single family homes.

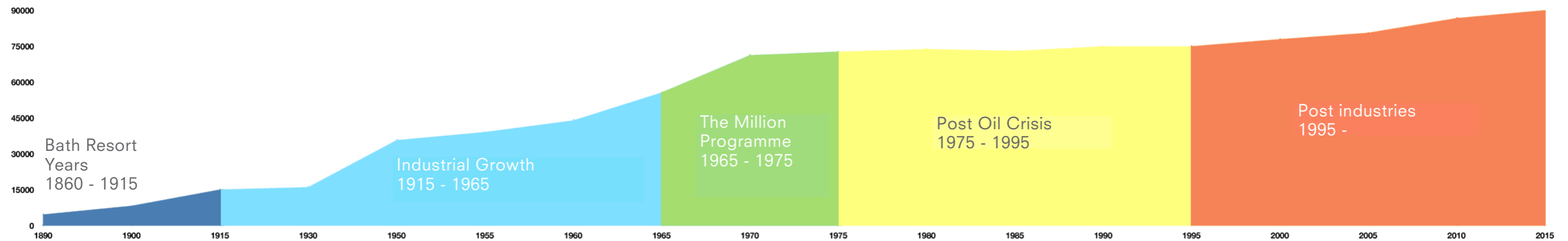
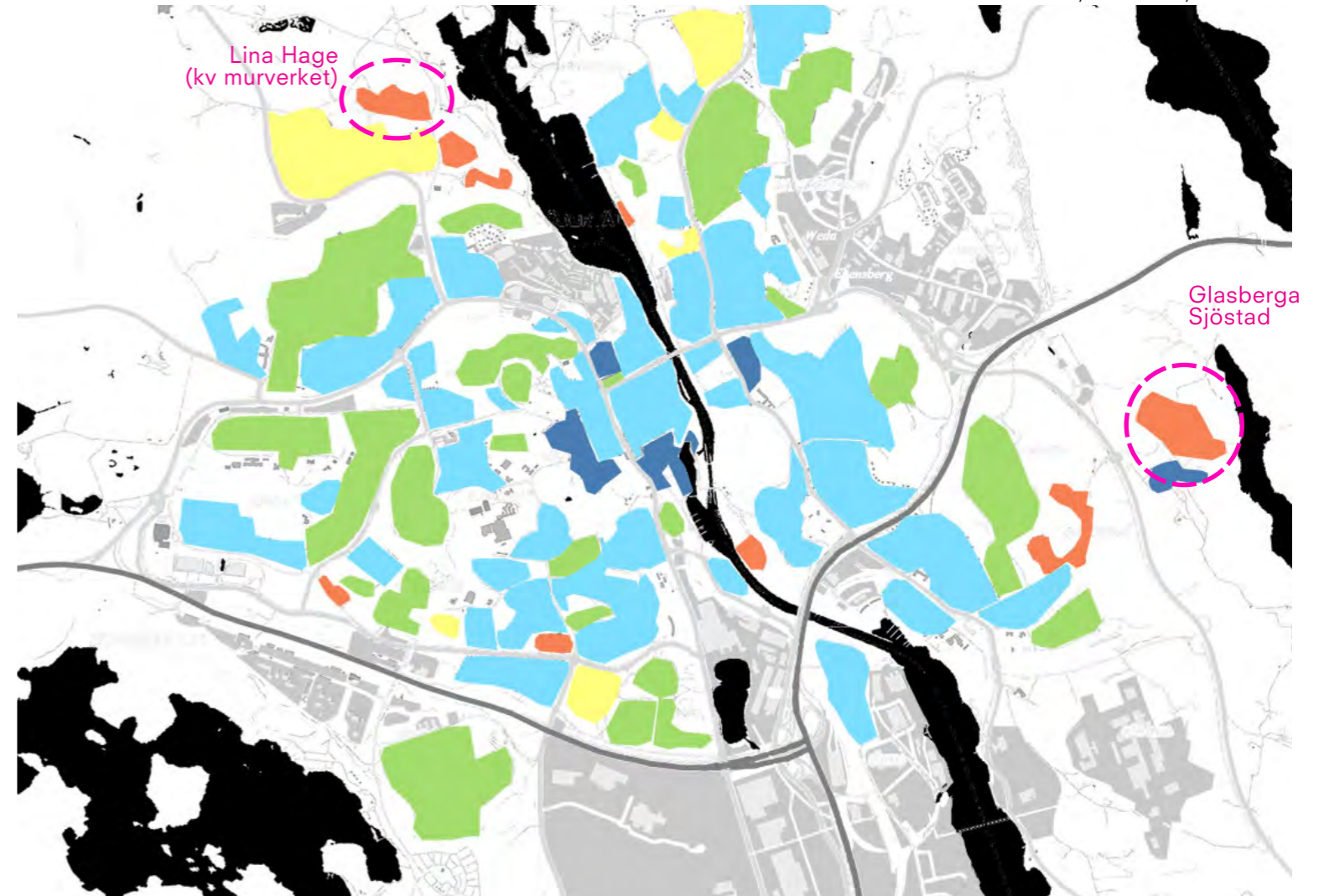

Chapter 2 Code Wars

The attempted stimulation of the market worked perfectly in Lina Hage. The plots were sold quickly and created a wave of demand for similar plots elsewhere in town. The development showed that there was an urge for other types of housing, both in aesthetics and content. A majority of settlers in Lina Hage belong to the Assyrian/Syriac group, and Lina is one of the first residential areas that express their presence architecturally.

But a wave of critique and discontent started to build. The home owners association (Villaägarna) - dominated by affluent and conservative people with deep reach into local business and politics - was the strongest opposer. Some saw Lina Hage as proof that the Assyrians didn't want to assimilate into the Swedish system, but rather build their own.

Rolf Bengtsson was the former chairman of Villaägarna and one of the top politicians in the conservative party, Moderaterna. In an article in the town's major newspaper, Länstidningen, he explains his discontent in the Assyrian/Syriac population's lack of gratitude and adaption:

"It is clear that you (Assyrians/Syriacs) do not want to be involved in our organizations and be a part of our society. Maybe you have your own organizations, I don't know. In any case this is no good."

A good example of lack of participation is found in our residential areas. It is difficult, nearly impossible, to get participation from the Assyrians/Syriacs in our organized work. What are you afraid of?

What was it you wanted when you came here? Do you not want to be a part of our community - be a part of Södertälje? You have to adapt your way of life, and your way to do business, to how we do things in this society."
- LT, 2010

Bengtsson further developed his argument in a later article in the same newspaper:

"For a long time, Moderaterna has tried to make the Planning department take their responsibility in conserving local building traditions. Allowing people to build however they want, resulting in these Mediterranean palaces, risk to destroy our town. We should not make ugly something with such a beautiful geographical location as Södertälje."

Somehow, he soon had his prayers answered, in the form of Glasberga. Sjöstad.

Felicity Scott on Settling as a Non-Normative Action

"Wheeler's ranch (a code free utopian settlement in northern California) was at once a manifesto for freeing the land or ceeding it back to the commons and an invitation to participate in testing the limits of the police and legal system's (let alone neighbors') tolerance for the commune's battle against private ownership of land and their unconventional behaviour. And the local authorities (like the neighbors) did, of course, fight back, giving rise to what came to be known as "code wars" and with them an escalating set of tactical and countertactical maneuvers between the commune, on the one hand, and local and state governing institutions on the other. It was during this battle that the non-normative structures of Wheeler's ranch, structures which served not only as an expression of identity but also a mechanism of settling Open Land, emerged as key sites and key components both of this countercultural refusal of normative modes of life and of the local government's mode of defense against it."

- Bulldozers in Utopia, 2012

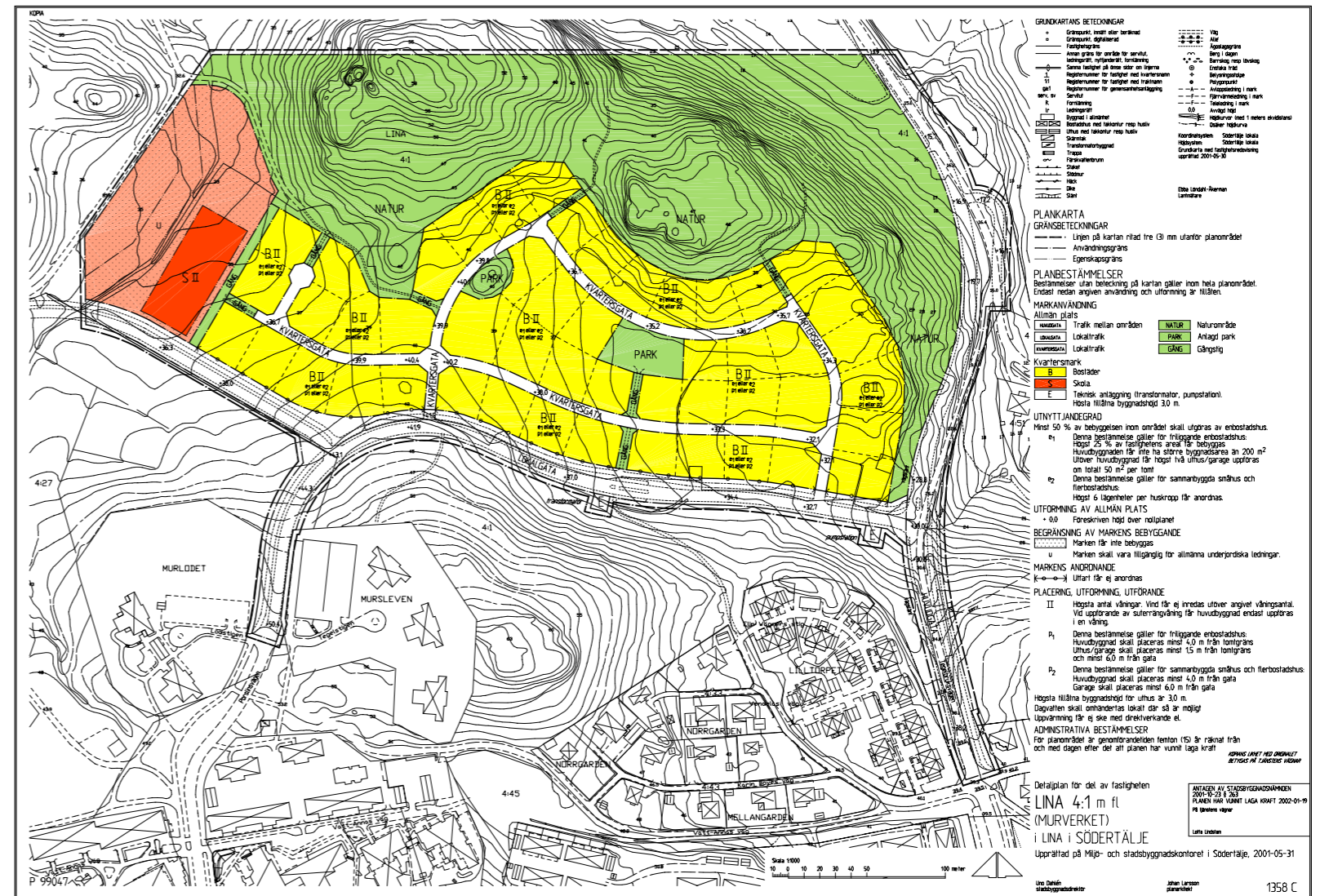

Lina Hage and its Inhabitants

Residents seem happy and proud of their neighbourhood, and at the same time confused by what is going on in Glasberga:

"The mix (in Lina Hage) has a charm in itself, and we have to accept that taste is individual. Some houses I didn't like to start with, but as time goes I have come to appreciate them to."
- Ebba Åkerman, Agnes Söderlunds väg, Lina hage

"In Glasberga all the houses look the same, you are not even allowed to chose the color of your own house or what to do with your yard. Why? Lina is much better, it's like with flowers on a meadow you know, the more different flowers, the better the meadow"
- Samir Haddad, Jenny Lidmans stig, Lina Hage

"Wooden facades doesn't fit a house in town, though it may be nice to live in one for the ski-holiday. It's not that we do not like Sweden. This is our home, our country now, this is where

we want to live and invest our money. But like everyone else, we want to do it according to our own heads."
- Edward Hana, Agnes Söderlunds väg, Lina Hage

"A neighborhood like Lina Hage is a clear image of a well integrated society. You live side by side and you see each other everyday. Maybe you hate each other's houses, but you say good morning and ask about the car regardless. Not like in Stockholm, for example, where you can live an entire life without ever really mixing with other ethnical groups."
- Bengt Andrén (m), ex. planning manager, 2008

The Glasberga Design Program

The Design program was written as a complement to the Master plan. Its is made up of explanations of the building restrictions and a kind of Manifesto for this Swedsh middle class utopia. The Design Program is very much a response to the building traditions which started to form in Lina Hage and elsewhere in town. No stone facade or walls, no elaborate roofs or building volumes, only low-key dormers, restricted building sizes, very limited siting and a pre-set of colors and materials.

"Our ambition is to make this the most attractive area in Södertälje that caters to modern families with a demand for a close connection to nature and water.

The architecture in Glasberga will be characterized by modern and stylish simplicity. This, combined with Swedish building traditions, will result in a genuine neighbourhood. All buildings will be characterized by beautiful, clean shapes; creating a consistency in architecture (although details and colors can be somewhat different for the sake of variety and vitality). The houses will adapt to the terrain of the plot, making for a residential area with beautiful slopes. The color scheme will harmonize; yellow ochre, rich reds, brown and black. The roofs will be red or gray-black. The facades of will be a combination of wood and plaster, where the choice of paint enhances the true character of the materials."

- Thomas Eriksson, representative from JM



Robert Venturi on planning from above

"In dismissing Levittown(Lina Hage), modern Architects (Planners), who have characteristically promoted the role of the social sciences in architecture, reject whole sets of dominant social patterns because they do not like the architectural consequences of these patterns. Conversely, by defining Levittown as "silent-white-majority" architecture, they reject it again because they do not like what they believe to be the silent white majority's political views. These architects reject the very heterogeneity of our society that makes the social sciences relevant to architects in the first place... they build for Man rather than for people - this means, to suit themselves, that is, to suit their own particular upper-middle-class values, which they assign to everyone."

- Learning from Las Vegas 1972

Change of Plans

At first, the plan was that all four actors involved in the planning of Glasberga were going to be equally involved in construction. A close collaboration would secure that the Design program was respected.

But when the Socialdemocrats came back into power in mid 00's, they decided to withdraw from the project and put their focus elsewhere. New plots elsewhere with Lina Hage-type regulatins made the competition fierce, and land in Glasberga was proving hard to sell. In 2008, a new disposition of the still

unbuilt plots were made. All four initial actors withdrew and the private plots were divided between the companies Götenehus, Älvsbyhus and private persons (right image). This made the Design program hard to impose, but the new political majority were not that worried about that:

"The conflict arose as soon as the Glasberga Company decided to sell lots as detached villas and townhouses instead of building there themselves. When people build according to their own dreams, there will be difference between the homes

regardless of the design program. Especially in a city like Södertälje.

Obviously, the Planning department try to adjust the zoning to reduce friction, but this is how the people of Södertälje actually want their houses to look like today. Defining what others home should look like can not be done, and to divide a city into homogeneous house districts is simply not right."

- Staffan Norberg, Current planning manager, 2012

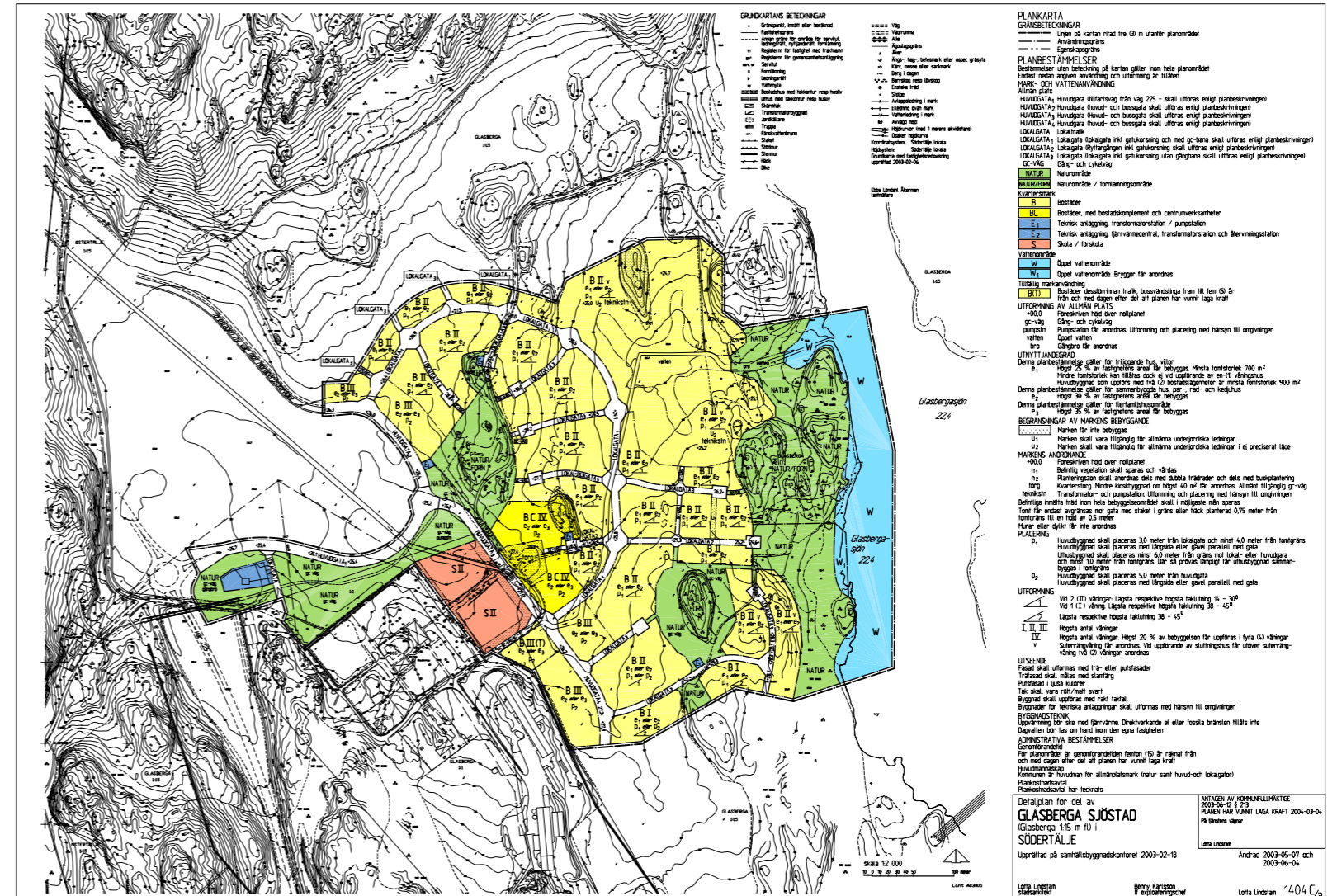

The re-disposition of plots from 2008

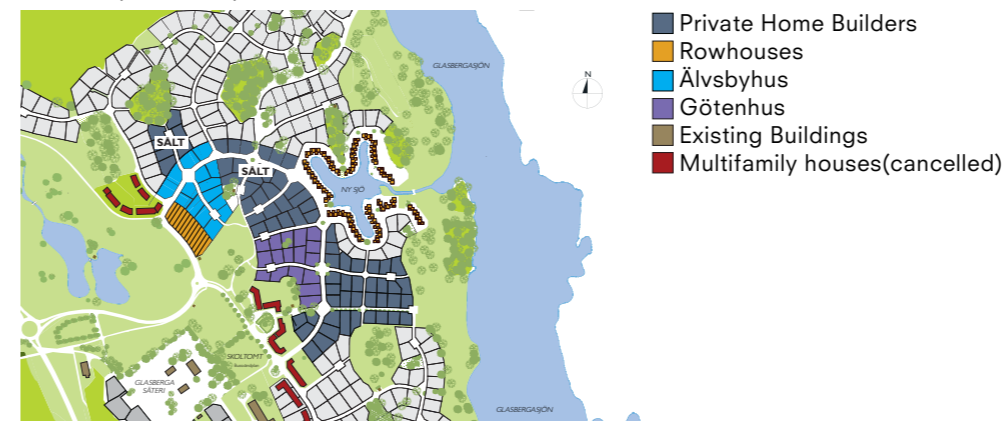

Chapter 3

The Glasberga Building Codes and How they Materialize

Visual regulations:

Volume

- The building volume should follow our local traditions and be rectangular.
- Eventual dormers should be moderate in size and adapted to overall design.
- Despite traditional values, our contemporary view on architecture should be featured in design, with adaptation to functions which are crucial for us today: windows, patios and detailing.

Facade

- Limewashed-painted wood or
- Plaster in the following colors:



Roof

- The roof's shape should be simple and traditional, complex shapes are not allowed
- 2-storeys 14-30°
- 1-storey 35-45°
- Metal sheets or concrete tiles in following colors:



Hedge/Fence

- If hedge: Hornbeam (avenbok) or Pivet (liguster)
- If fence: Wood painted dark green
- Stone walls are foreign to a garden city why these will not be allowed.

Plot regulations:

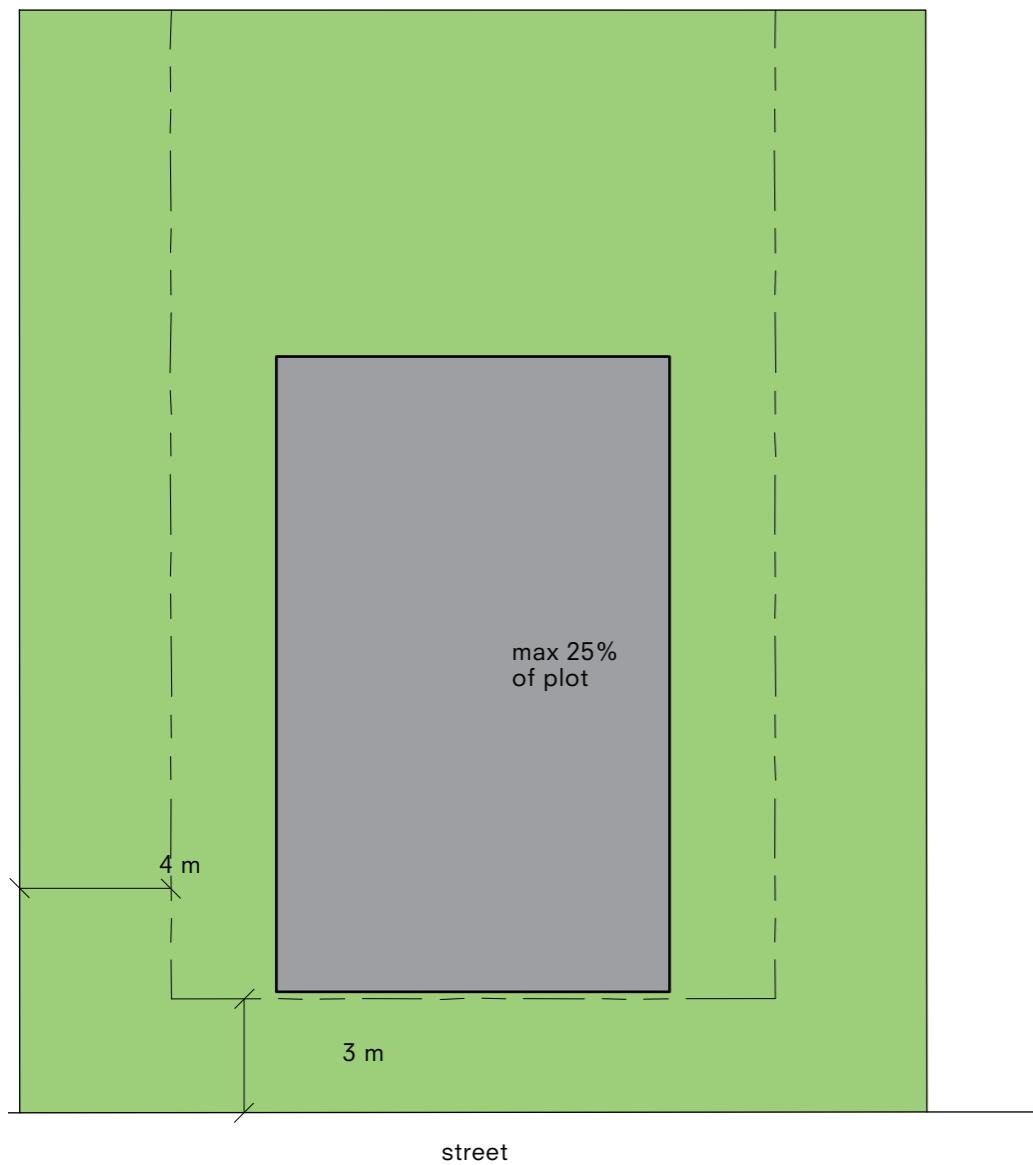

Volumetric variations within regulations: (* = volumes used by developers)

	1 storey *	2 storeys	1+1 storey	2+2 storeys
45° pitch				
15° pitch				
pen roof				
to the side				
backyard				
elevated				
going further				
cutting off				

Chapter 4 Norsholm

Red, 150 m²

The company given the most plots, 17, was Götenehus. They decided to put the standard house Norsholm on all 17 plots. Norsholm comes in 2 storeys with a cast-on-site slab and prefab polonceau trusses. The walls are divided up in a grid of 2x2 m. >

On their website, Götenehus describes Norsholm:

"The covered veranda with its beautiful woodwork make guests feel welcomed. Inside there is a kitchen, a dining and living room, all integrated into an open and harmonic floor plan with light and volume. On ground level there is a bathroom with shower and a laundry room. The latter is accessed from the kitchen as well as from the outside through."

"On the upper floor there is a bathroom, a study, a larger and two smaller bedrooms. There is also a common room in between these."

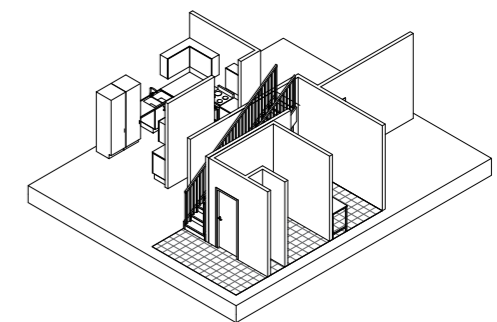
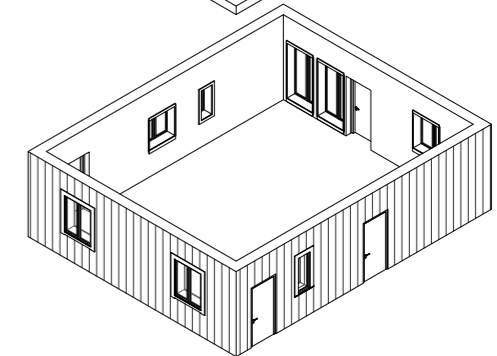
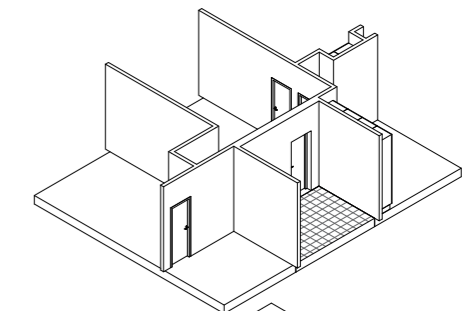
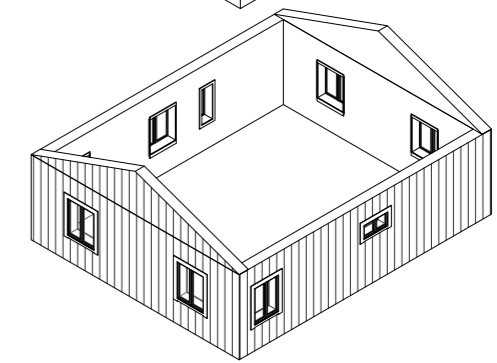
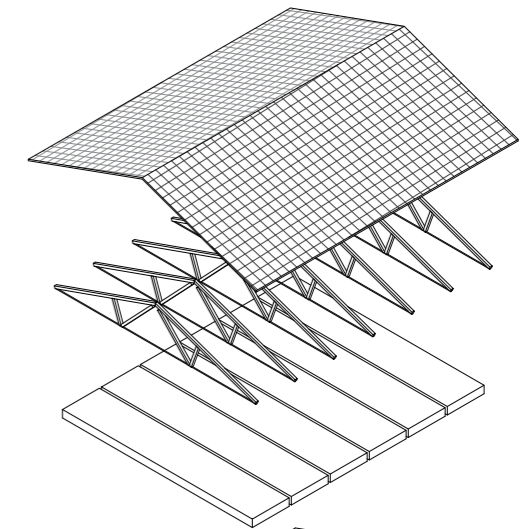
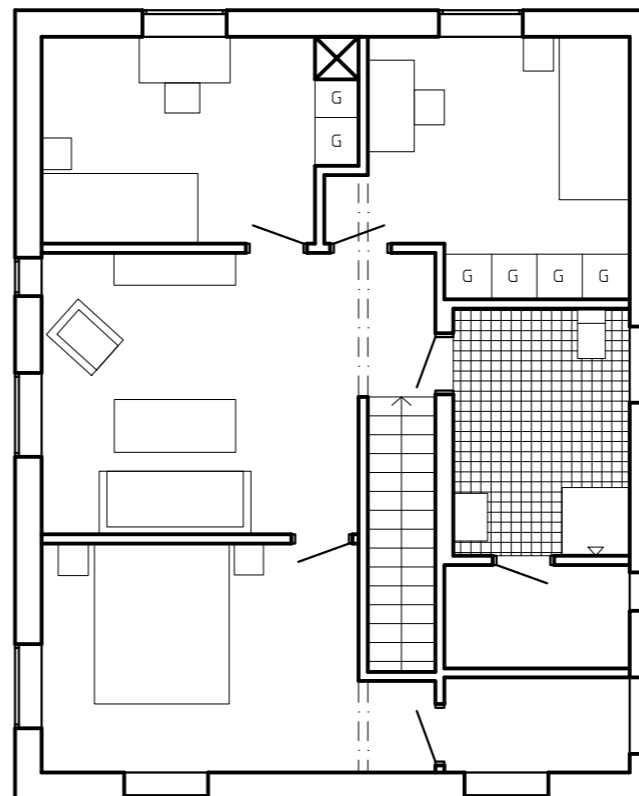
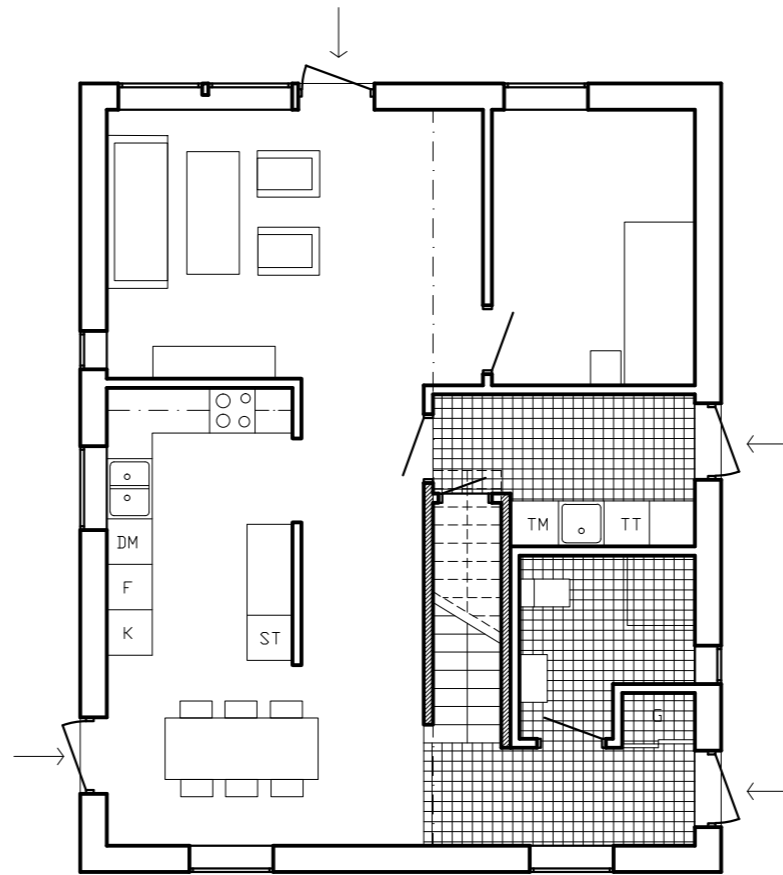
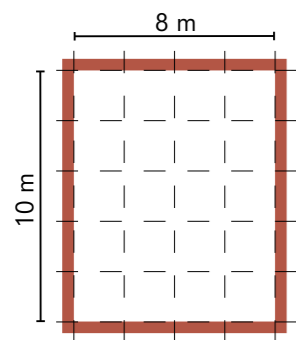

Chapter 5 Problems

01 Hollow Ambitions of the Vernacular

The Design Document of Glasberga says:

"The beautiful Swedish simplicity - which has shaped our building tradition since the middle ages to modernity - is a desirable goal for the design of the new houses. The buildings should be simple and traditional with pitched or pen roof, and materiality should be linked to local building tradition" (gestaltningsprogrammet, 2003)

We can argue that this "Swedish simplicity" has two origins:
-Since the "middle ages", the poverty and harshness of the Scandinavian climate and how it

has been coped with.

-In "modernity", the idea of mass-production, equality, and an inclusive price tag. These two traditions locate their arguments in necessity and ideology. In Glasberga, the Design document requests the builder to imitate these traditions (limewash, pitched roof and timber facades) although the element of necessity is no longer there. This is post-modernity imposed by the planning authorities with the contradictory claim of being vernacular, and with the intention to impose uniformity.

Venturi on Vernacular
"While architects have adapted the simple forms of vernacular architecture, they have largely ignored the complex symbolism behind it. They themselves have used the vernacular vocabularies symbolically, to suggest association with the past and the simple, deterministic virtue, that is, as early examples of a correspondence between structural methods, social organization, and environmental influences."
- Learning from Las Vegas 1972

Equally problematic is the argument of Glasberga respecting the local building traditions and existing buildings stock (exposed intensively in promotional material). Both the aesthetics and functions of the pre-existing buildings on site are in conflict with the building restrictions, and actually have more in common with the houses in Lina Hage.

From Vernacular to Post-Modern
1850, Roslagen



- Mullions reduce cost of glass
- Copper tinted paint to protect from rot
- Roof pitch is a result of roofing method

1940, Norra Ängby



- No mullions reduce cost of window
- Plastic paint was modern and cheap
- Roof pitch a result from prefab trusses

2011, Glasberga



- Mullions glued on
- Limewash is prescribed in masterplan
- Roof pitch result from masterplan
- Dimensions according to transportation limits

Contradictions

The old farm in Glasberga



"The facade material should be limewash-painted wood or plaster, why stone will not be allowed"

- Gestaltningsprogrammet

Gate to Glasberga Manor



"Fences and gates should be painted dark green."

- Gestaltningsprogrammet

Glasberga Manor



"Roofs should be pitch or pen, oversized dormers or broken roofs are not allowed."

"Facades colors such as white or pink are foreign to local building traditions why these will not be allowed."

- Gestaltningsprogrammet

02 Urban Planning from Above or Below

Apart from the aesthetics, a common characteristic of the homes in Lina Hage and its successors is that their program has evolved to include more than a home. They are expanded to contain a business and/or salon for up to 50 people where the extended family or guests can gather (zhao, 2011).

As a response, the planning authorities have chosen to fight this form of development. In glasberga they have created restrictions that result in smaller smaller houses, limited freedom of architectural expression and restricted siting. This unveils a clear conflict between planning from above, as in glasberga, and planning from below, as seen in lina hage (Mack, 2011).

The low demand of land in glasberga, and the fact that many developers have chosen to ignore the restrictions and realize their own designs, shows that the planning authorities are making decisions out of context, and fails to cater properly to the citizens desires and how they want to architecturally express themselves.

Businesses/Resident on the Streets of Lina Hage

- > 0.25
- 0.20 - 0.24
- 0.15 - 0.19
- 0.10 - 0.14
- < 0.9



Haddad House
Lina Hage
420 m²

- 5 Bedrooms/3 Bathrooms
- Inviting ground floor, 3.5M ceiling height, 50m² salon
- Imported stone facade
- Garage for 2 cars and parking for 3 more
- Flat and easy-to-take-care-of garden
- Upper floor open to possibilities

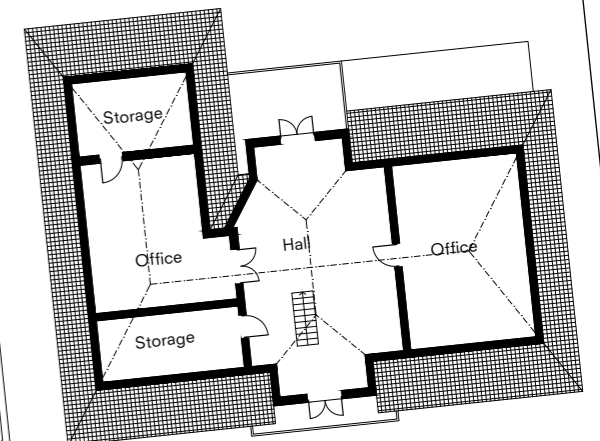
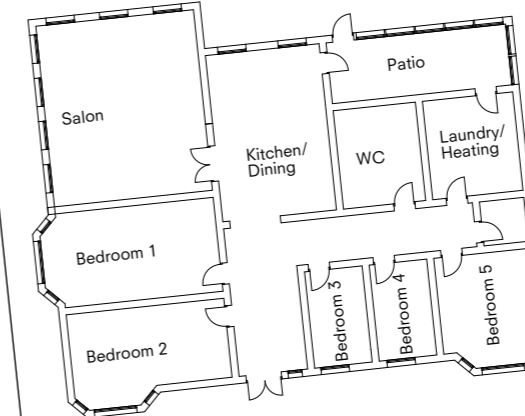

The functions and aesthetics of the old Glasberga Manor is very much like the Haddad house of Lina Hage.

03 Segregation as a Goal?

The promotional images of Glasberga show a bizarre vision of how the authors envision life in a Södertälje suburb.

The website www.Glasberga.se states that Glasberga will become the exemplary suburb in Södertälje addressing the demographics of "modern families with kids who search for an active life close to nature and water".

Götenehus is the company that has been commissioned to build most houses in Glasberga. Through their catalogue, this company communicates a quite specific characteristic of the inhabitants and their lifestyle.

Through words and images, Glasberga seems to be planned to impose segregation. There is an wish of who to live here. It excludes both ethnic and social groups.

Thomas Hylland Eriksen, prof. in Social Anthropology, on Normality
 "In today's Swedish society there are two groups, independent of each other, which are outside what is considered normal. The first is immigrants, and the second is people who can't or won't compete in society's race, without a dynamic life-project, family or career and unable/unwilling to take part and collaborate."
 From the radio programme Filosofiska Rummet, Sveriges Radio 2008.

Promotional pictures from www.glasberga.se

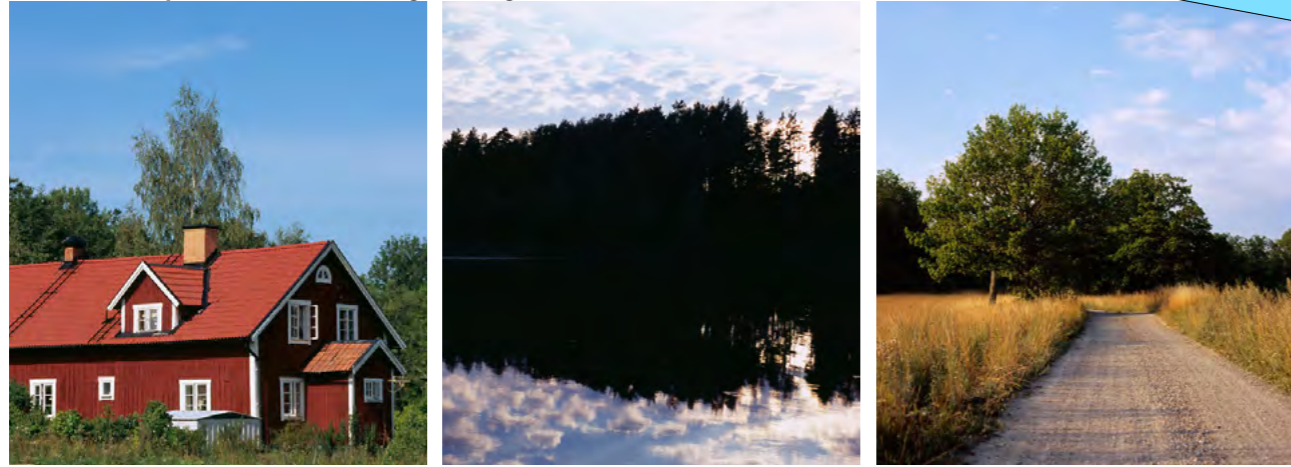

Promotional pictures from Götenehus



Promotional pictures from Götenehus

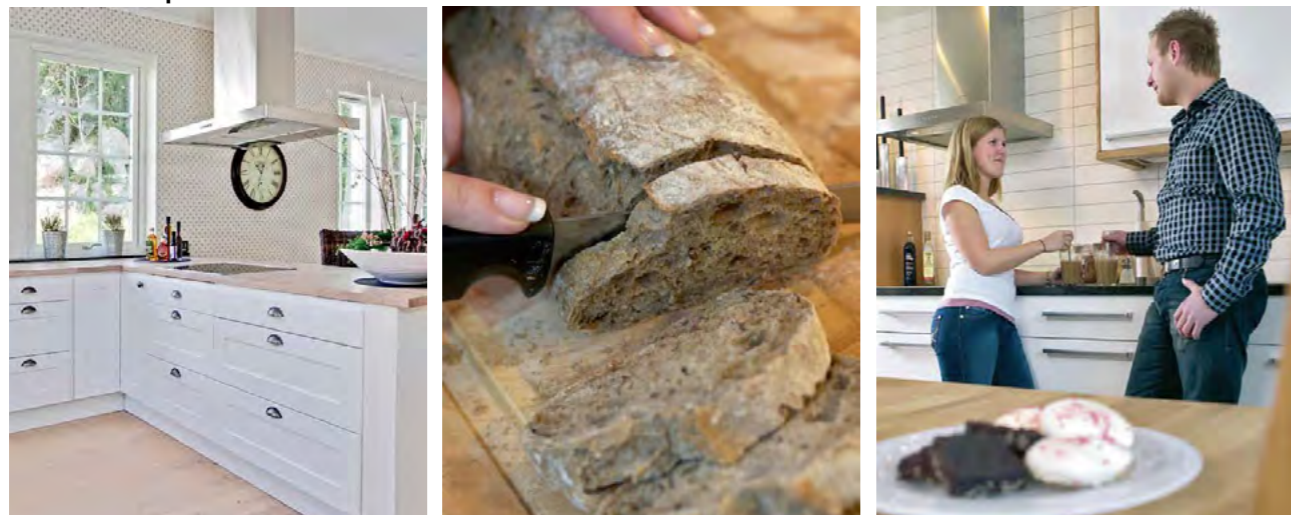

04 The Economic Barrier

The average price for a single family house in Södertälje is 14 300 sek/m² (according to www.hemnet.se in april, 2013). In Glasberga that number is 25 100 sek/m².

This is the major suburban development in Södertälje with 600+ new homes built over 10 years. But the price level makes it an option for a minority of the town's population.

This difference is typical for a Swedish town. What makes Glasberga special is that it is isolated from other parts of town and it has a size much larger than any other housing suburb.

So the segregation problem is as much economic as it is ethnic/social.

Erik Friberger, Pioneer of the Element House, on its advantages:
 "The advantage and of the ready made house is that the techniques and possibilities of modern architecture is utilized to create better and cheaper houses. Houses that easily can be adapted to changing needs and economic conditions."
 1936

Prices sek/m² for villas in Södertälje

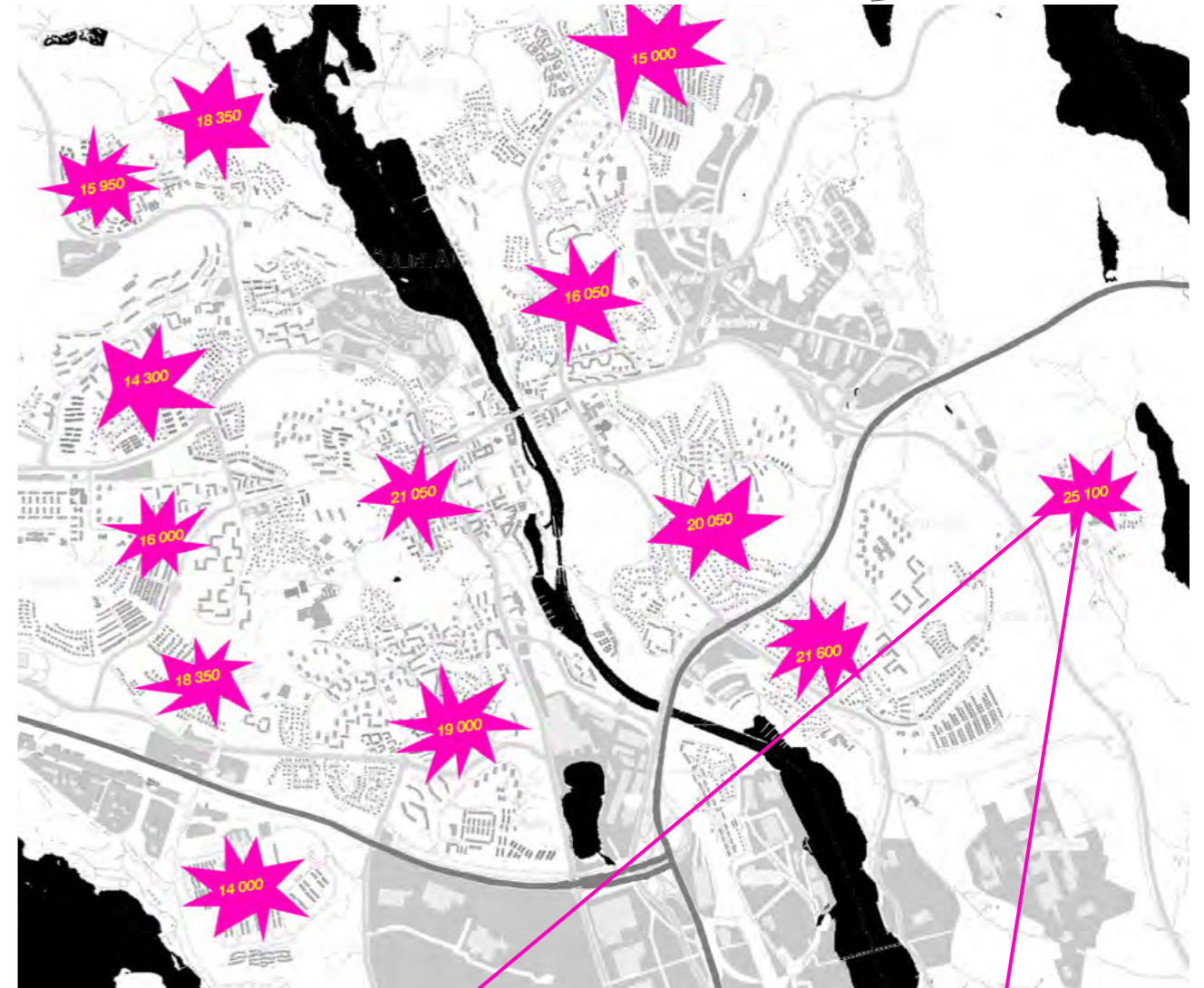

Trollöngatan mfl 3 334 750 kr

Fakta
 Byggnadsyta: 138 m²
 Skulle: 100 m²
 Tomtearea: 7 400 m²
 Dufvarens: 22 000 kr

Glasberga 3 273 250 kr

Fakta
 Byggnadsyta: 139 m²
 Skulle: 100 m²
 Tomtearea: 6 400 m²
 Dufvarens: 22 000 kr

Chapter 6 Breaking Down

The initial question was about the role and potential of Swedish suburbia and how it could be expanded to address a wider spectrum of the population.

Glasberga and Götenehus symbolize the contrary of what I am searching for:

- Götenehus sell houses to a specific and niched group of people - affluent, white families.
- Glasberga is extracting this section from the rest of town and clusters them in a monocultural colony.

I don't see Lina Hage as the model example of

a suburb, but it holds so much more promises than Glasberga. In Lina you buy land, but what you put there is up to you, both the blessings and the consequences. Among the people there I

talked to, difference and specificity is not seen as problems to be solved.

The existential dimensions of choosing where to put a wall for your own house is important. But in Glasberga the walls are already there.

More than 3/4 of the plots in Glasberga are still to be built upon. Götenehus is going to build on a lot of those.

My proposal is a collection of alterations of their house Norsholm. they address different forms of living than the one in the catalogue. Focus has been on living alone or in group and having home and work in the same place. As a vehicle for these alterations, I have used the stories of people close to me. None of these people live in their own, or in a family, but all of them would like, or even need, to have a house of their own, a piece of land of their own.

The role of Södertälje's planning departments would be to include smaller plots in the future expansion of Glasberga. Plots that would sell for much less and open up for more people.

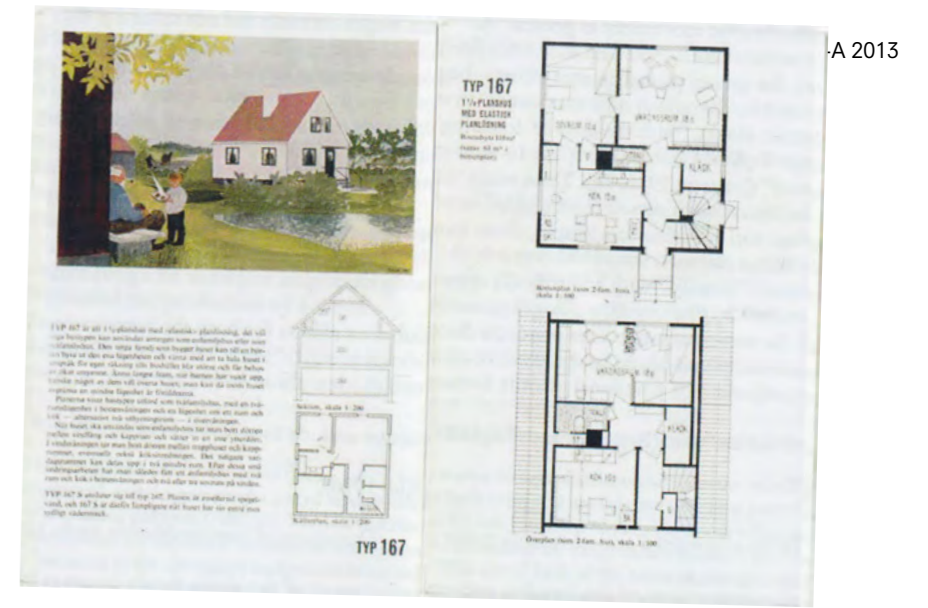

A House for the Home-Worker 160 m²

- Living quarters 36 m²
- Loading area with garage
- Ground slab
- Workshop on ground floor

This home is based on the life of my former boss, who runs a small carpentry in a residential area. His current apartment, which lies above his workshop, is practically a hotel room where he sleeps and showers. The rest of his life he spends downstairs - watching television, meeting friends, working, eating etc.

His business is a hub in the neighborhood where the locals come to drink coffee, talk and get help with home repairs.

My house for him has street has the workshop entry facing the street. Next to this is a loading area from which you reach the workshop. On the back side of the house there is a private entry that reaches the kitchen, the toilet and the stairs which goes to the private quarters and the storage.

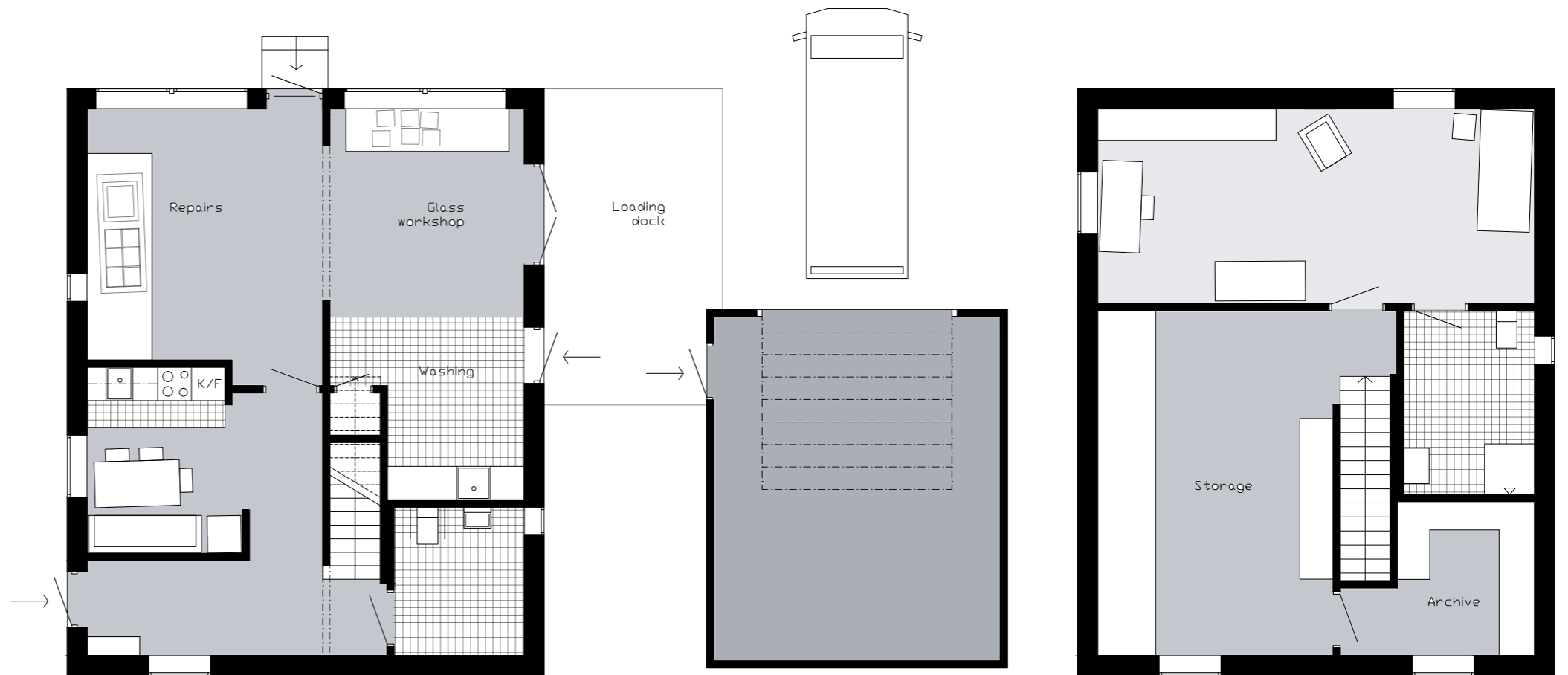
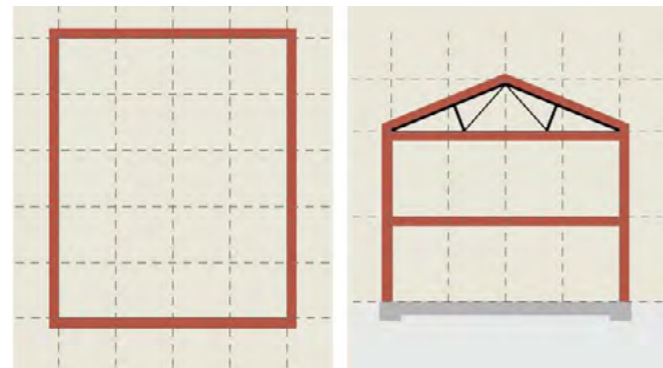

B House for the Co-Op's 344 m²

- 8 bedrooms
- Atrium
- Ground slabs
- Shared laundry
- External entrances and stairs

The first version is a Co-op house that strives to reduce the costs and risks for a group of people to build their own private apartment building. It is made up of two units of Norsholm with a void in between that is the heart of the settlement.

To save space, the entrances and stairs are put on the outside. Each floor is a separate apartment that can be further divided into two depending on the inhabitants. The shared laundry room lies below the stairs in the space between the houses. This space is covered to

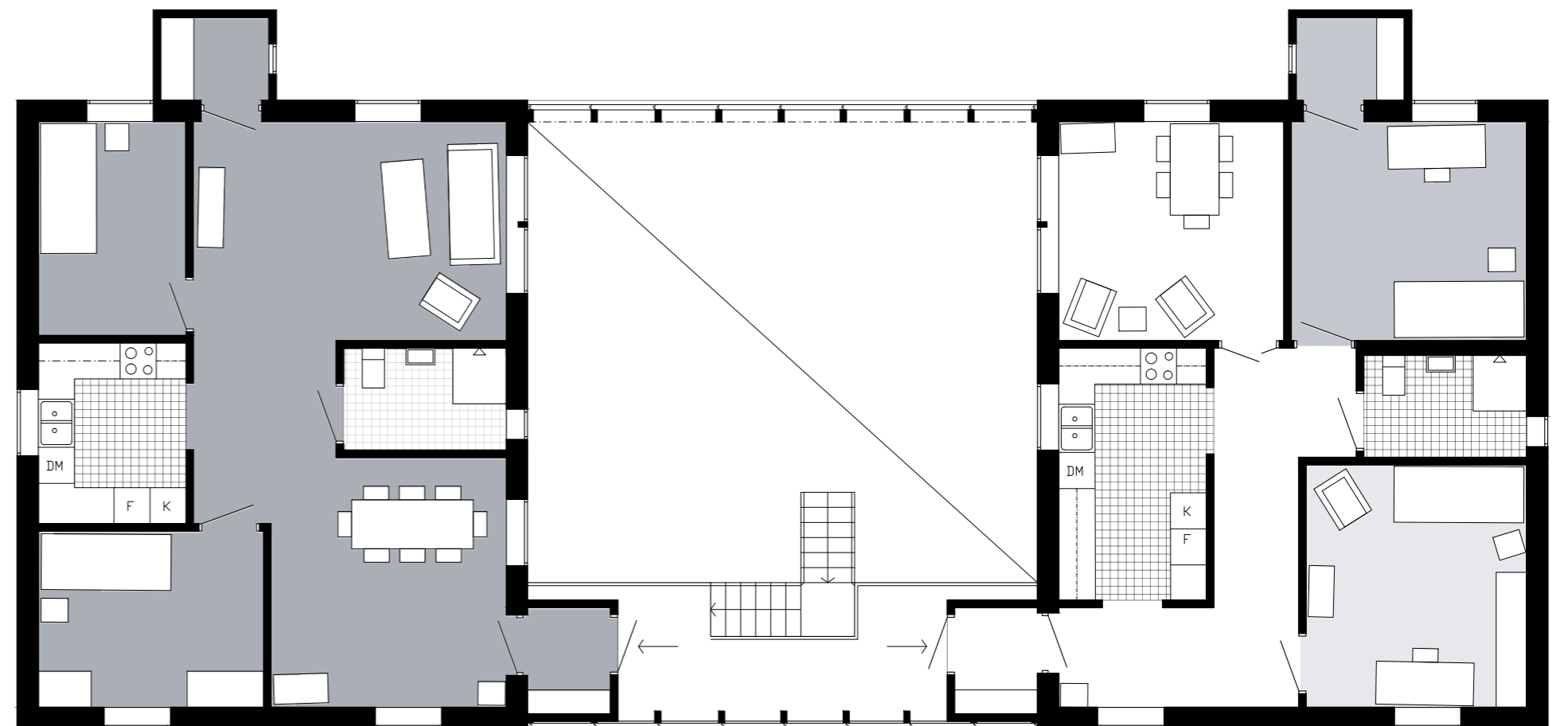
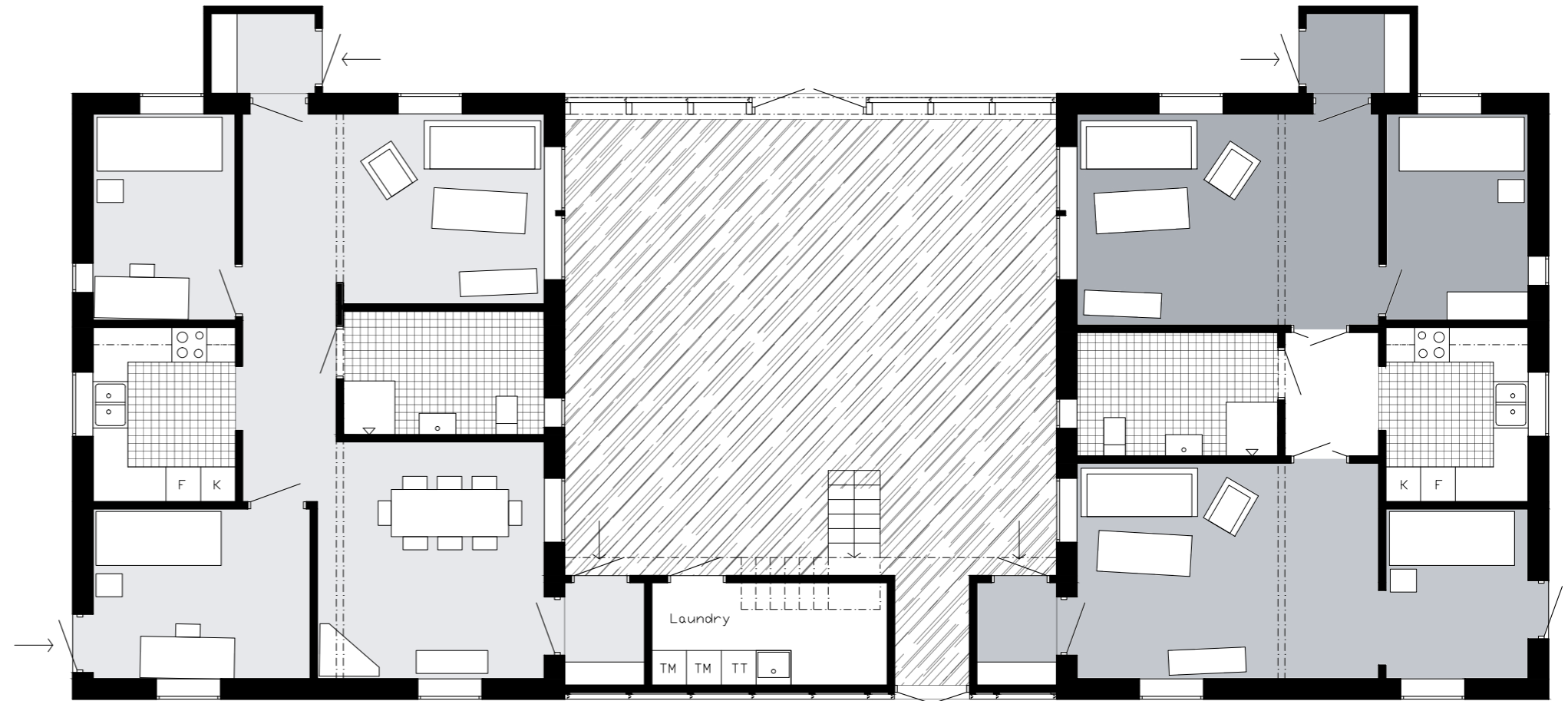
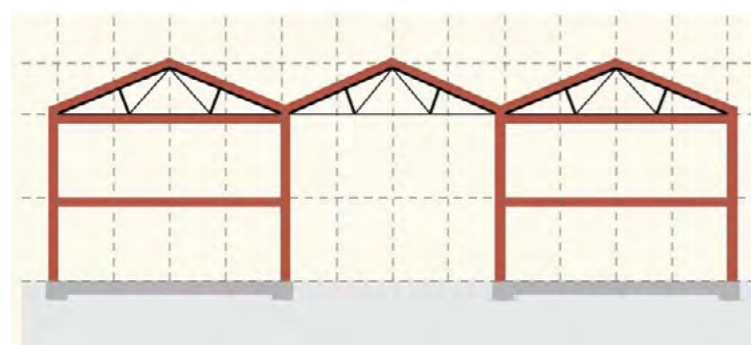
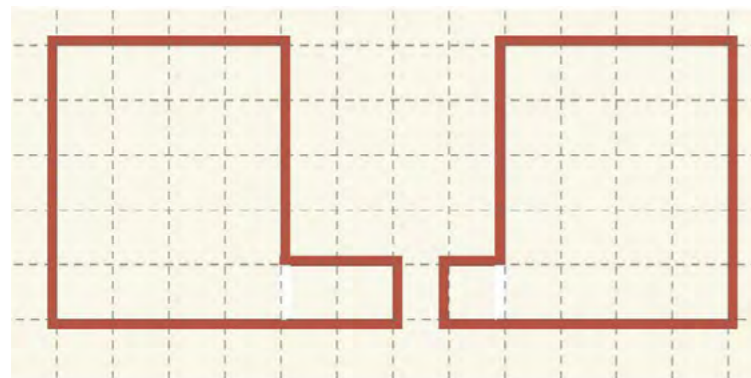

C House for the Self Involved Solitaire, 60 m²

- Bare trusses
- All wood, half-decomposed by the time the self involved solitaire passes away
- Wooden plinths

This house dies with its occupant, making it easier for the person to relate to that horrible but beautiful ending. Until that day, they can grow together as one. Opening up, or closing in on the world as they seem fitting.

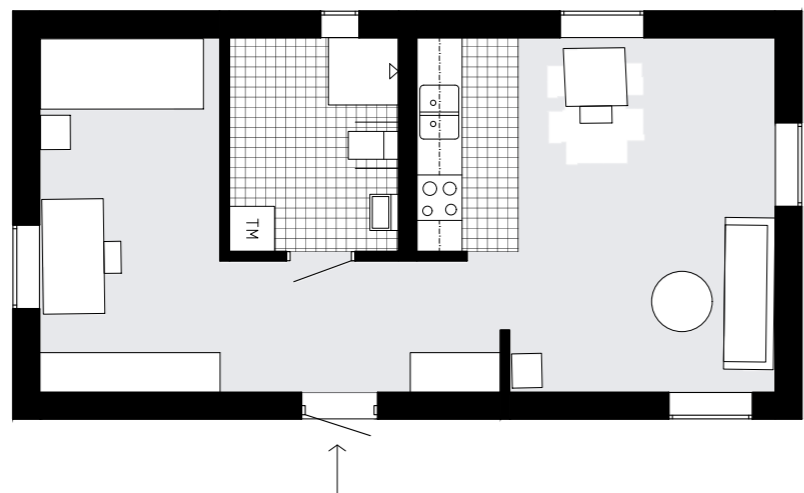
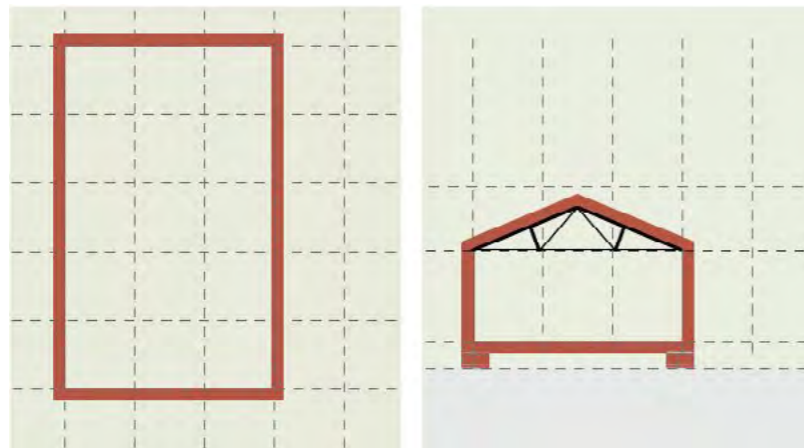
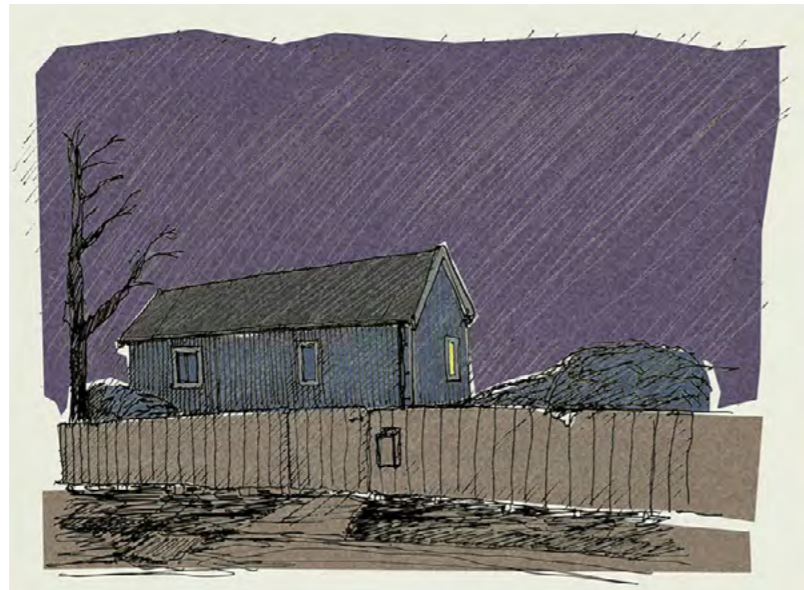

D House for the Reluctant Service-Taker, 48 m²

- 1 person
- Plinths
- 4 windows/one door

The home for a person with endless need for freedom and privacy, but also a great need of care.

