

**Innovation in Hybrid Mass Timber High-rise Construction: A Case Study of UBC's Brock
Commons Project**

by

Azadeh Fallahi

B.A.Sc., The University of British Columbia, 2015

A THESIS SUBMITTED IN PARTIAL FULFILLMENT OF
THE REQUIREMENTS FOR THE DEGREE OF

MASTER OF APPLIED SCIENCE

in

THE FACULTY OF GRADUATE AND POSTDOCTORAL STUDIES

(Civil Engineering)

THE UNIVERSITY OF BRITISH COLUMBIA

(Vancouver)

April 2017

© Azadeh Fallahi, 2017

Abstract

With the advocacy for sustainable construction on the rise, use of timber as the main building material is being championed in large-scale construction projects. While the advancement of engineered timber products is addressing some issues that previously limited the use of wood in high-rise construction, there are still challenges such as fire and weather safety, code compliance and negative public perceptions. One main gap in the available resources is the lack of a comprehensive and detailed case study of a high-rise project with wood as the main construction material to capture constraints and innovations necessary in creating success, which has formed the direction of this research.

This thesis is focused on documenting a case study of the Brock Commons project, an 18 storey, hybrid timber-concrete residential high-rise located at the University of British Columbia, Vancouver campus, which is the tallest hybrid timber building in the world. The overall research objective was to identify and document the delivery of this innovative project, with a specific emphasis on the innovations necessary to make timber high-rise construction successful and the use of VDC tools in the design and pre-construction process.

The case study documents the project context, the design process, the business and industry drivers, and the motivation for construction. Moreover, it investigates the motivations for all stakeholders, identifies the challenges and constraints, and captures the innovative solutions that were utilized to ensure project success. The case study also documents the innovative use of VDC to support prefabrication and overall project coordination. Specifically, it investigates the role of the VDC integrators in the project, the paths of communications with the different project team members, and the inputs and outputs of each phase of design and construction.

This research identified lessons learned that can be applied to other construction projects where timber is the main structural component and a heavy use of VDC and pre-fabrication is required. Use of timber and innovative methods in construction have been consistently rising in the past decade, and this research aims to provide a starting point for future efforts in mass timber high-rise construction.

Preface

All images, figures and tables used in this research include references to the owners and are used with the permission of the applicable sources. Any figures without acknowledgements, are developed and created by the author.

Table of Contents

Abstract.....	ii
Preface.....	iv
Table of Contents	v
List of Tables	viii
List of Figures.....	ix
List of Abbreviations	xiii
Acknowledgements	xiv
Dedication	xv
Chapter 1: Introduction	1
1.1 Background.....	1
1.2 Case Study Motivation.....	6
1.3 Research Objectives.....	7
1.4 Research Scope	8
1.5 Thesis Outline	8
Chapter 2: Literature Review.....	10
2.1 Construction Innovation.....	10
2.2 Pre-fabrication.....	12
2.3 Design for “X”	13
2.4 Virtual Design and Construction (VDC)	14
2.5 Literature Review Conclusion	15
Chapter 3: Case Study.....	16

3.1	Project Description.....	16
3.2	Industry Context.....	20
3.3	Business Context.....	21
3.3.1	For British Columbia	22
3.3.2	For UBC.....	23
3.4	Site Context.....	25
3.5	Design Process Summary	26
Chapter 4: Methodology.....		30
4.1	Research Activities	31
Chapter 5: Project Innovations		39
5.1	Concrete Cores.....	39
5.2	CLT Slabs	45
5.3	GLT and PSL Columns.....	49
5.4	Building Envelope	54
5.5	Specialty Construction Considerations.....	62
5.5.1	Water Management during Construction.....	63
5.5.2	Fire Safety and Management during Construction.....	68
Chapter 6: Innovative Uses of Virtual Design and Construction.....		75
6.1	VDC Integrator Software.....	75
6.2	VDC Model Evolution and Use Workflow	77
6.3	Preliminary Design Phase.....	78
6.3.1	VDC Preliminary Design Stage Inputs:.....	79
6.3.2	VDC Preliminary Design Stage Products:.....	81

6.3.3	VDC Preliminary Design Stage Outputs:	81
6.4	Design Development Phase	82
6.4.1	VDC Design Development Stage Inputs:	83
6.4.2	VDC Design Development Stage Products:	86
6.4.3	VDC Design Development Stage Outputs:.....	88
6.5	Mock-up and Project Construction Phase.....	90
6.5.1	VDC Construction and Mock-up Stage Inputs:	91
6.5.2	VDC Construction and Mock-up Stage Products:	92
6.5.3	VDC Construction and Mock-up Stage Outputs:	94
Chapter 7: Conclusion		95
7.1	Lessons Learned.....	95
7.2	Summary of Innovations.....	103
7.3	Limitations and Future Work.....	105
Bibliography		106

List of Tables

Table 1-1 Structural systems of well-known timber buildings globally modified from (Foster et al., 2016)	3
Table 3-1 External funding available for a timber solution (Poirier et al., 2016).....	24
Table 4-1 Research activities for each sub-objective	30
Table 4-2 Data collection per research activity	38
Table 5-1 Concrete core process flow	41
Table 5-2 CLT process flow	47
Table 5-3 Column types: Extracted from the supplier shop drawings.....	50
Table 5-4 Column process flow	51
Table 5-5 Envelope panel process flow	60

List of Figures

Figure 1-1 Industry preconceptions of wood (Green & Karsh, 2012).....	2
Figure 1-2 Mixed-material tall timber building typologies (Foster et al., 2016).....	3
Figure 1-3 WIDC in Prince George (Courtesy of bccasn.com)	4
Figure 1-4 LCT One in Dornbirn (Courtesy of woodday.eu).....	5
Figure 1-5 TREET in Bergen (Courtesy of timberdesignandtechnology.com).....	6
Figure 3-1 Left: Architect rendering of the project (Courtesy of AOA), Right: Brock Commons under construction (Courtesy of Naturally: Wood)	16
Figure 3-2 Typical floor layout (Courtesy of AOA).....	17
Figure 3-3 The various building materials used in Brock Commons (Courtesy of AOA).....	18
Figure 3-4 Building envelope panels and curtain wall system (Courtesy of AOA).....	18
Figure 3-5 MEP coordination done in VDC to determine exact locations of penetrations and pre- fabricate mechanical room.....	19
Figure 3-6 Left: The Landing, Right: The Leckie (courtesy of Citycaucus.com and fremarconstruction.com).....	21
Figure 3-7 Brock Commons site (Courtesy of AOA).....	26
Figure 3-8 Constraints in pre-fabrication.....	28
Figure 3-9 Hand-off, constraints, responsibility and tolerances process map	28
Figure 3-10 View of the mockup with one type of prefabricated panel	29
Figure 4-1 Research activity sequence and roadmap.....	31
Figure 5-1 the lift n' lock system, (Courtesy of Aluma Systems).....	40
Figure 5-2 The work platforms for workmen and core boxes (Courtesy of CadMakers Inc.)	40
Figure 5-3 Concrete core schedule for the two cores, picture taken at the site trailer.....	41

Figure 5-4 Installation sequencing (as highlighted in red) (Courtesy of UrbanOne Builders)....	46
Figure 5-5 Wood wraparound on the steel stud structure for added flushness (Courtesy of RDH)	
.....	55
Figure 5-6 Flashing detail (Courtesy of RDH)	56
Figure 5-7 Envelope cross section showing the connection details and the envelope	
section(Courtesy of AOA)	57
Figure 5-8 Panel types for the building enclosure (Courtesy of UrbanOne Builders).....	57
Figure 5-9 Envelope plant, jigs fixed onto the floor, for each different panel type.....	58
Figure 5-10 Building envelope plant	58
Figure 5-11 Mockup testing (Courtesy of RDH).....	59
Figure 5-12 Original water management strategy at fabrication plant (Courtesy of UrbanOne	
Builders).....	64
Figure 5-13 Original water management strategy (Courtesy of AOA)	65
Figure 5-14-Moisture protection at different stages of the CLT panel (Courtesy of RDH)	65
Figure 5-15 Original rainwater strategy (Courtesy of AOA).....	66
Figure 5-16 Revised rainwater strategy - Adding the number of exposed floors to be able to pour	
concrete and tank floors (Courtesy of AOA).....	67
Figure 5-17 Revised rainwater strategy approved by Vancouver Fire and Rescue Services -	
Adding the number of exposed floors to be able to pour concrete and tank floors (Courtesy of	
AOA).....	73
Figure 6-1 3D EXPERIENCE suite by Dassault Systemes	76
Figure 6-2 Left: Structural option 1a. (beam Option), Right: Structural option 3a. (2-way slab	
Option) (Curtesy of CadMakers)	78

Figure 6-3 Inputs, products and outputs of the VDC model during preliminary design phase	79
Figure 6-4 Preliminary structural design hand sketches (Courtesy of Fast and Epp).....	80
Figure 6-5 3-day design workshop (Courtesy of Acton Ostry Architects).....	80
Figure 6-6 VDC products during the preliminary design stage.....	81
Figure 6-7 Left: Cost estimations done by the construction manager during the design workshop (Courtesy of UrbanOne Builders), Right: Bidders package supplementary information (Courtesy of CadMakers Inc.)	82
Figure 6-8 Inputs, products and outputs of the VDC model during design development phase ..	83
Figure 6-9 Architectural design development drawings used as input for the VDC model	83
Figure 6-10 Right: Mechanical design development drawings used for VDC, Left: Structural design development drawings used for VDC	84
Figure 6-11 VDC integrator official communication with the design team	85
Figure 6-12 Constructability issues identified in the design development phase by the VDC integrator (Courtesy of CadMakers Inc.).....	86
Figure 6-13 Constructability issues identified in the design development phase by the VDC Integrator (Courtesy of CadMakers Inc.).....	86
Figure 6-14 CLT panel dimensions from the coordinated model in the design development phase by the VDC integrator (Courtesy Of CadMakers Inc.).....	87
Figure 6-15 Design development VDC model (Courtesy of CadMakers Inc.)	87
Figure 6-16 Mechanical room coordination by VDC integrators during design development phase	88
Figure 6-17 Fire-stopping locations and details incorporated into the VDC model.....	88

Figure 6-18 MEP modeled in VDC, turned to BOM and installed on site (Courtesy of CadMakers Inc.).....	89
Figure 6-19 Mechanical Room VDC, turned to BOM and installed onsite (Courtesy of CadMakers Inc. and UrbanOne Builders).....	89
Figure 6-20 Rebar and MEP canning location coordination in VDC.....	90
Figure 6-21 Inputs, products and outputs of the VDC model during construction and mock-up phase	91
Figure 6-22 VDC Integrator and construction team and trade meeting onsite to discuss construction activities	92
Figure 6-23 VDC model and shop drawing developed by the VDC integrator during mock-up stage (Courtesy of CadMakers)	92
Figure 6-24 Construction sequencing 4D and VDC model for concrete cores (Courtesy of CadMakers).....	93
Figure 6-25 4D of loading and installing of the envelope panels and GLT columns.....	93
Figure 6-26 The "Outrigger" location and movement 4D for interior work.....	94
Figure 6-27 Construction strategy document highlighting the placement of column bundles (Courtesy of UrbanOne Builders).....	94
Figure 6-28 Installation sequencing of the CLT panels.....	94

List of Abbreviations

UBC: University of British Columbia

UBC SHHS: UBC Student Housing and Hospitality Services

UBC PT: UBC Properties Trust

NRCan: Natural Resources Canada

RFI: Request for Proposals

SI: Site Instructions

CO: Change Orders

CLT: Cross-Laminated Timber

LVL: Laminated Veneer Lumber

GLT: Glued-Laminated Timber

AEC: Architecture, Engineering, Construction

LOD: Level of Detail/Development

PM: Project Manager/Management

MTP: Mass Timber Panels

VDC: Virtual Design and Construction

Acknowledgements

This research is the result of continued support from a large number of amazing people. First and foremost, I want to thank my research supervisor, Dr. Sheryl Staub-French. It was first in her class as an undergraduate student that I realized my passion for construction management and it was only reinforced in my second class with her during my senior year, that I decided I wanted to pursue this as my master's degree. It was her continued guidance and encouragements that made this possible. Additionally, I have to thank Dr. Erik Poirier, as without his guidance in shaping me as a masters student, I would never have been able to finish this research.

I also want to express my immense gratitude to all the project team involved in the UBC Brock Commons project, for their support and generosity of giving me their time and knowledge to help me paint a holistic picture of the happenings on and off site. I specifically want to thank Karla Fraser and Bill Leininger from Urban One Builders, for always making time for me, and taking the time to walk me through the latest developments, as well as providing mentorship for me.

I also want to thank all my fellow students and colleagues at the BIM TOPiCS lab for their encouragement and feedback along the way and for lending a hand whenever I needed one. Last but definitely not least, I have to thank my amazing family for never doubting me even when I wasn't sure along the way, and for providing the best role models for me and shaping me into the person I am today.

Dedication

I dedicate this thesis to my given family and my chosen family. Thanks for being in my life.

Chapter 1: Introduction

1.1 Background

In recent years, the use of sustainable/green building practices have come to the forefront of the construction industry as there have been a wide spread push for a sustainable development agenda (Adeli, 2009; Brundtland, 1987; Szeto et al., 2014). This has led many in the industry and academia to consider using timber in area previously not explored. The use of wood in housing construction has been widely adopted in North America from the days of the early settlers in the form of heavy post and beam construction, due to the abundance of forest resources. Since then, the process has accelerated due to the lowered cost of machine-made nails and use of water-powered saw mills to produce properly cut and planed pieces of wood. That, as well as the relative ease of construction with light frame wood (compared to heavy masonry) has contributed to the system being the preferred method mostly for single family residential constructions (Burrows, 2014; “Wood Frame Construction,” n.d.).

Use of Mass Timber Products (MTPs) has been overshadowed by wood stick-frame construction and despite ancient examples of mass timber buildings having withstood the test of time, modern interpretations of mass timber have stayed relatively low. According to an industry survey done in the book “A Case for Tall Wood Buildings” by Michael Green Architecture, industry preconceptions illustrated in Figure 1-1 were identified as barriers of entry for MTP into high-rise construction (Green & Karsh, 2012):

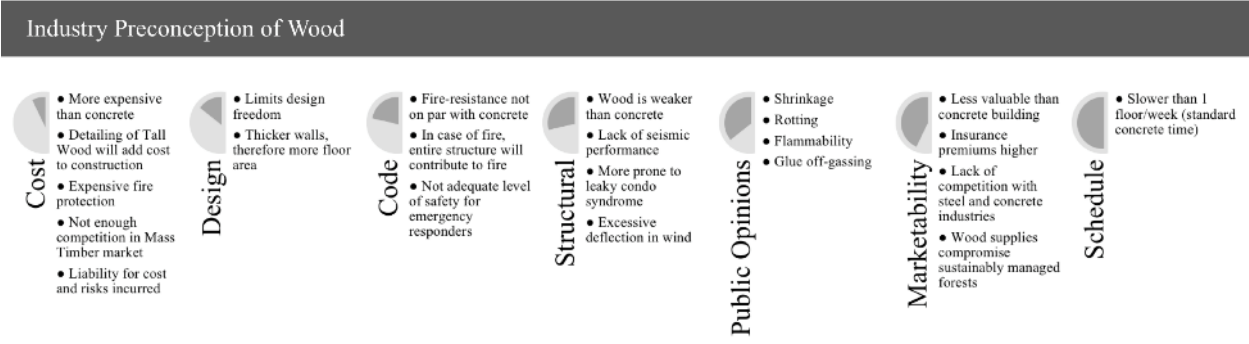

Figure 1-1 Industry preconceptions of wood (Green & Karsh, 2012)

A number of literature addresses these perceived disadvantages, and provide solutions and strategies to mitigate each as the industry is beginning to divert their attention to using MTPs for mid-rise and potentially high-rise construction. Issues of weather protection, fire safety and structural soundness are being addressed through specialty engineered timber products, and novel construction strategies are ensuring projects can be competitive with the traditional building materials such as concrete and steel both in terms of schedule and cost (Barber & Gerard, 2015; Foster et al., 2016; Gasparri et al., 2015; Green & Karsh, 2012; Öqvist et al., 2012; Robinson et al., 2016; Van De Kuilen et al., 2011)

With the new wave of efforts being put in the realization of “tall timber” buildings, there have been studies on how to use timber in conjunction with other traditional building materials, and how to leverage each material’s structural strengths to the fullest. In a forum paper published by the American Society of Civil Engineers (ASCE), the authors have looked at the modern and recent examples of tall timber buildings and have identified the following building typologies in mixed material building as illustrated in Figure 1-2 (Foster et al., 2016):

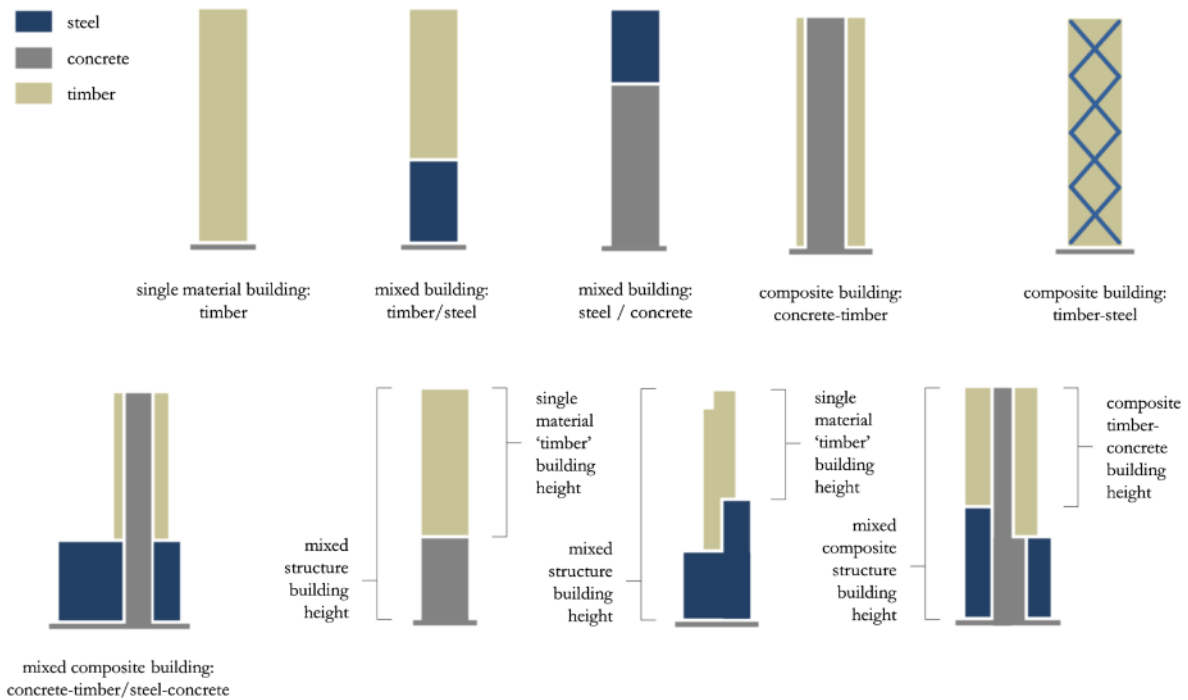

Figure 1-2 Mixed-material tall timber building typologies (Foster et al., 2016)

Table 1-1 shows a list of well-known timber projects globally and the structural system adopted:

Table 1-1 Structural systems of well-known timber buildings globally modified from (Foster et al., 2016)

BUILDING	Location	# of Stories	STRUCTURAL SYSTEM		
			Vertical	Lateral	Flooring
WIDC	Prince George, BC	7	GLT Column, LVL, CLT Wall, TF	CLT Core	GLT, CLT
LCT ONE	Dornbirn, Austria	8	GLT Column, RC Wall, RCGF	RC Core	HBV
TREET	Bergen, Norway	14	GLT Columns, TF/CLT Modules, RCGF	Braced GL	TF, Braced GLT+RC/5th floor

GLT: Glue-laminated Timber, LVL: Laminated veneer lumber, CLT: Cross-laminated timber, TF: Timber frame, RC: Reinforced concrete, RCGF: Ground-floor podium and concrete transfer slab above

The three buildings while different in nature, share the extensive use of CLT as the preferred MTP for structural purposes. Below are short descriptions of each building:

WIDC: At seven stories tall and at 29.25 m, it is the tallest wood building in Canada, located in Prince George, BC (Figure 1-3). On top of the CLT and GLT, the building utilizes LVL in the entrance canopy and the feature stairs. The connections are glued-in perforated steel plates (HSKTM system), aluminum dovetail Pitzl connectors in GLT columns and self-tapping screws (Naturally Wood, 2015).



Figure 1-3 WIDC in Prince George (Courtesy of bccassn.com)

LCT ONE: Finished on November 2012, the LCT ONE building is the first 8-storey timber hybrid building in the world (Figure 1-4). Located in Dornbirn, Austria, the building's main structural element is the GLT columns used, which is combined with some concrete and a systemized, prefabricated approach entitled "LifeCycle Tower (LCT) system" which is where the name of the building has originated from (Tahan & Zangerl, 2013). Designed by Hermann Kauffman, the advisory architect in Brock Commons, the pre-fabricated elements of the building were aimed to have rapid installation times to accelerate the schedule. The envelope panels were pre-fabricated and designed to be erected at a pace of one floor per day, and together with the

CLT panels, they were able to decrease construction time from 14 months to 11 months, compared to a typical concrete build project (FII & BSLC, 2014).



Figure 1-4 LCT One in Dornbirn (Courtesy of woodday.eu)

TREET: A 14-storey building located in Bergen, Norway (Figure 1-5), is the tallest contemporary timber building in the world (45 meters above concrete foundation). The building has some reinforced storeys that take on the loads of the floors above, before the next “power storey”. These reinforcements are through load-carrying GLT trusses. The building has a CLT elevator shaft internal walls and balconies, however the CLT is not load bearing. Finally, weather protection of the timber elements is done through glass and metal sheeting protection (Abrahamsen & Malo, 2014).



Figure 1-5 TREET in Bergen (Courtesy of timberdesignandtechnology.com)

1.2 Case Study Motivation

One aspect all timber projects to date have had in common has been to display the timber in the buildings as aesthetic features. There are arguments against doing so, as exposing the timber can both pose safety concerns such as fire and would require the timber to have an aesthetic grade which adds costs to the project. While all the projects mentioned were admirable achievements in modern use of timber, currently, the UBC Brock Commons project is the tallest hybrid timber building in the world, which is why it was chosen as the case study for this research.

Due to the novelty of MTPs current overall construction costs are higher than concrete buildings, and as UBC intended for the building to stay cost competitive with other concrete buildings, it was necessary for the project to be built faster than when using concrete. A pre-fabricated approach was chosen for this project to ensure that the designed building elements are precise, and waste is limited to help keep the project on budget, price competitive and most importantly fast. In order to combat the uncertainties in precision, installation and performance, on top of the

rigorous design and approvals process, a Virtual Design and Construction (VDC) approach was used in both the design and construction process using a third party VDC integrator. These innovations in the product and process were also the reasons that made this building a valuable research subject as these practices are not standard in the industry yet and there are few literature that capture these processes in detail.

1.3 Research Objectives

The overall research objective was to identify and document the delivery of the UBC's Brock Commons Project, the tallest hybrid mass timber high rise in the world. Two Sub-Objectives (SOs) were explored:

SO1: Investigates various innovations necessary in the successful construction of a hybrid timber-concrete high-rise, including use of pre-fabricated and optimized modular elements, the unique installation processes on site and capturing timber-specific construction strategies to mitigate potential safety and quality issues on site.

SO2: Investigates the role of the VDC integrators and their selected tool in the project and identifies the various and continual communications lines with all the project team members, the VDC model inputs and outputs of each phase of design and construction, and the VDC products of each phase.

Finally, the thesis identifies specific lessons learned for this project, and outlines constraints and points of interest during the different sections.

For each of the selected SOs, various research activities have been defined and specific data collection and analysis assigned to each activity, which is explained in greater detail in chapter 4 and summarized in Figure 4-1, Table 4-1 and Table 4-2.

1.4 Research Scope

This research has monitored and documented the processes during the pre-construction and construction phase for the UBC Brock Commons project. The research has focused on capturing all areas of innovation in the project, and has refrained from documenting processes that are standard and common practice in the industry. This has translated to capturing information related to the VDC modelling, the pre-fabrication and other factors directly relating to the use of the selected material (timber) in the project. This research has focused on the construction aspects of the project, and has not discussed the structural design rationale and the specifics of permit approvals. Finally, this research is not delving into budgets and costs and since as of writing this thesis, the commissioning and life cycle analysis are still underway. Finally, any comments on the success and long-term performance of the building are omitted as they are outside the scope of research.

1.5 Thesis Outline

This thesis consists of six chapters. Chapter two conducts some literature review to identify the history and current means of innovation in the construction field, including the use of pre-fabrication, modular construction and VDC (Virtual Design and Construction). Chapter three provides a brief introduction to the selected case study, the Brock Commons project and looks at it through the regulatory context, industry context, site context and business context. Chapter four describes in further detail the methodology used in conducting this research, including the

data collection relevant to each research activity and how the research activities contribute to the identified SOs. Chapter five presents the findings of the research, in the shape of a detailed description of the building elements, their construction and fabrication steps, the installation sequencing on site and specialty construction processes to mitigate any risk of damaging the timber elements for the first SO, product innovation. For the second SO, process innovation, the research captures the different stages VDC was incorporated into the project, and inputs and outputs in each of those phases. Finally, chapter six looks at specific lessons learned and discusses the effectiveness of using timber for the UBC Brock Commons project and provide a summary and identifies limitations and future work to be done.

Chapter 2: Literature Review

This chapter reviews literature that is relevant to this research, innovation in construction, use of pre-fabrication and modularization as a form of innovation, and the use of VDC to support the delivery of construction projects.

2.1 Construction Innovation

When talking about innovation in construction, it is important to first define and then characterize “Innovation”. One proposed definition of innovation by the Organization for Economic Cooperation and Development is that it is the “Creation of new products, services, or business processes that create wealth or social welfare”(OECD, 2010). This definition is an important one as it opposed the more classic notions of innovation that portrays it as a linear one that only fits in high-technology industries (Loosemore, 2015). Further, it has been re-iterated by multiple researchers that when talking about innovation, the ideas do not necessarily have to be considered innovative globally, but rather be considered so in the specific context of the industry being discussed (Dulaimi et al., 2005; Seaden et al., 2003; Sexton & Barrett, 2003).

When discussing innovation in the context of construction, one argument is that due to the uniqueness of every project, there are significant opportunities for new approaches and some consider those innovative behaviors (Seaden & Manseau, 2001). However, there are counter arguments for this mentioning the lack of motivation to use innovation (as the knowledge gained is obsolete when moving to next project) and lack of economy of scale as the main hindrances of innovation (Pries & Janszen, 1995). Additionally, another challenge in widespread adoption of innovations implemented and proven successful in a project, is the transfer of knowledge. Innovations developed for problem solving are not effectively documented and communicated, and hence rarely become commercialized by manufacturers (Slaughter, 1993; Veshosky, 1998).

Innovation has also been noted as more than creativity and invention, but rather that it includes commercialization, implementation and entrepreneurship as part of the process. This requires a change in culture to proactively promote and support innovation. In the book, *Managing the Professional Practice in the Built Environment*, author Jeremy Watson states that historically the innovation process has progressed from “technology push” to “demand pull” to “concurrent innovation”. He identifies “open innovation” as the latest and currently most rapidly growing innovation process in which ideas are traded in the open market place created by the internet. In this process, would-be intellectual property buyers place their technology needs on a site, while technology providers add their contributions. Watson describes this as a potentially disruptive approach with the power to abolish traditional research and design methodologies for driving innovation (Watson, 2011).

Increasingly when talking about innovation in construction and the future, literature focuses on using “lean” delivery methods for construction projects. It is mainly argued that minimization or attempting elimination of waste is the driving force for lean construction methods (Bølviken & Koskela, 2016; Formoso et al., 2015). This car manufacturing strategy inspired approach has been proposed by Koskela (1992) as he identified eleven guiding principles for its implementation. Of the eleven, a few specifically address pre-fabrication and decreasing cycle times, both of which are implemented in Brock Commons (Koskela, 1992). There are also literature arguing that applying a motor vehicle production line strategy to construction is not feasible as the standard industrial classifications (SIC) used as the basis for national accounts do not allow the comparison of like with like. It further argues there might not be a deficiency in innovation in the construction industry as there are no conclusive data signifying that when

compared to other industries properly considered as value systems, construction has a lower rate of innovation (G. M. Winch, 2003).

2.2 Pre-fabrication

Pre-fabrication is an off-site manufacturing process in which various materials are connected to building systems and form blocks of the larger final product (Tatum et al., 1986; G. Winch, 2003). Depending on the size of the modules and ranking from largest to smallest, they can be categorized into the following four types (Schoenborn, 2012):

- **Modular Structures:** Volumetric components that form a completed part of the building.
- **Panelized Structures:** Components comprised of a series of pre-fabricated elements, but not enclosed usable spaces by themselves. This is the case in Brock Commons, as the building elements were fabricated ahead of arrival on site, and while not making up fully enclosed modules by themselves, they were rapidly installed to create enclosed spaces, which was a mandate to protect the timber building elements from weather exposure.
- **Pre-fabricated Components:** A single assembly fabricated in the factory, typically due to hardship of construction on site
- **Processed Materials:** Building elements fabricated offsite, that make up the majority of construction material these days.

Pre-fabrication has also been identified as the first degree of industrialization, followed by mechanization, automation, robotics and reproduction (Richard, 2005) and due to the fragmented nature of the AEC industry, the other degrees haven't been able to grow as much as pre-fabrication.

One of the main advantages in pursuing pre-fabrication is reduction in waste, both in terms of environmental impacts and project cost. Many point to studies that demonstrate the size of

construction waste in landfills. Back in 2006, construction consumed up to 60% of raw materials in the US, and of the 136 million tons of construction and demolition waste, only 20-30% were recycled (Ilozor, 2009). The reason pre-fabrication can greatly help reduce waste is the eliminations of site-factors such as over order, damage during transportation, loss during installation and poor workmanship which are the main contributors to waste production on site (Tam & Hao, 2014).

There is also evidence that when the pre-fabrication plant is working at full capacity, construction costs can be driven down to 85% due to reasons such as climate protection, having semi-skilled labour, bulk purchasing of materials and better quality control (Richard, 2005).

2.3 Design for “X”

Design for Manufacturing and Assembly (DFM & DFA) focuses on minimizing cost of product development and manufacturing and the proffered method of applying DFA is through systematic methods for analyzing assemblies (Holt & Barnes, 2010). Using BIM in aiding the prefabrication process is becoming exceedingly common where clash detection and constructability analysis are done from initial design stages to ensure the prefabrication is efficient and cost effective (Zhang et al., 2016).

This method of designing for a set goal early on is called design for X (DFX) and there are a variety of techniques associated with it. Bralla (1996) defined DFX as design for excellence and describes it as a “knowledge base to approximate the product design to the maximum of its desirable characteristics such as high quality, reliability, maintainability, safety, easiness of use, environment requirements, reducing the lead time for sales, reducing manufacturing costs, and maintenance product.” (Bralla, 1996)

The authors of “Engineering Design: A systematic approach” categorize the different phases of the design process as:

- Product Planning and clarifying the task
- Conceptual Design
- Embodiment Design
- Detail Design

This methodology is a means to establishing workflows and procedures during the early conception phases to ensure every design decision contributing to the desired end goal (Pahl et al., 2007). This was the case with the design process of Brock Commons, as all four of these phases were done in direct communication with the respective stakeholders, to ensure no decision was made that only benefited one team member and negatively affected another. From the early 3-day workshop all the way to installation sequencing on site, all the responsible parties, including the designers, the owner, the construction team and trades were included in the conversations that drove the final design for this project.

2.4 Virtual Design and Construction (VDC)

It has been well documented that the AEC industry is highly fragmented and iterative. This often translates to a lengthy and expensive design-construction process (Wood et al., 2014). Hence many companies and research institutions have taken on numerous initiatives to increase performance of the design-construction process. It is also imperative to understand the role of communication and collaboration between stakeholders in projects (Becerik, 2004; Farinha et al., 2007). Building Information Modeling (BIM) has been one of the more important strategies developed to increase this collaboration. While there are many definitions BIM, at its most basic level it can be defined as a “computerized process that is used to design, understand and

demonstrate the key physical and functional characteristics of a building (or construction or civil engineering project) on a ‘virtual’ computerized model basis” (Barnes & Davies, 2014).

While the use and adaptation of BIM has significantly increased in the past decade, there are deficiencies identified by scholars and researchers specifically in the field of management and communication of multi-disciplinary processes and information (Kunz & Fischer, 2012).

Introduced in 2001 by the Centre of Integrated Facility Engineering (CIFE), Virtual Design and Construction (VDC) has been defined as: “The method of Virtual Design and Construction is the use of multidisciplinary performance models of design-construction projects, including the Product, Process and the Organization of the design, in order to support business objectives” (Kunz & Fischer, 2012).

The three main components of every design and construction project are the product, the process and the organization. Using VDC, these components are visualized and made measurable with the use of drawings, models and simulations (Khanzode et al., 2006). In the case of Brock Commons, the installation sequencing and inter-disciplinary coordination for Mechanical, Electrical and Plumbing (MEP) with the structural elements were some of the products of this VDC process.

2.5 Literature Review Conclusion

Although much research has been conducted on innovation in construction, few efforts have connected the concepts of innovation, prefabrication, design for “X”, and the use of VDC, in a single study. Moreover, there have been limited case studies that closely study innovations in timber projects and present the challenges and lessons learned. This research addresses these gaps and contributes a rich case study that illustrates how these different innovative concepts can be leveraged to enable the delivery of the tallest hybrid mass timber building in the world.

Chapter 3: Case Study

3.1 Project Description

The UBC Brock Commons Phase I project is an 18 storey, 53m high, engineered mass timber building on UBC's Vancouver campus. This thesis investigates and documents innovations utilized in designing and constructing the project and draws conclusions and lesson learned to be adopted by the industry.

As pictured in Figure 3-1, Brock Commons is an 18-storey building that will house 404 students in single and quad occupancy units. On each of the floors from 2-18, there are 16 single units and two quad units (Figure 3-2), housing a total of 24 students per floor, except for the 18th storey, which has substituted one quad unit with a common area for residents. The ground floor, houses the mechanical, electrical and other service rooms as well as a collegium for commuter students on campus. The project was initiated in November 2014, design began in January 2015, construction began in November 2015 and is expected to be ready for occupancy by May 2017.



Figure 3-1 Left: Architect rendering of the project (Courtesy of AOA), Right: Brock Commons under construction (Courtesy of Naturally: Wood)

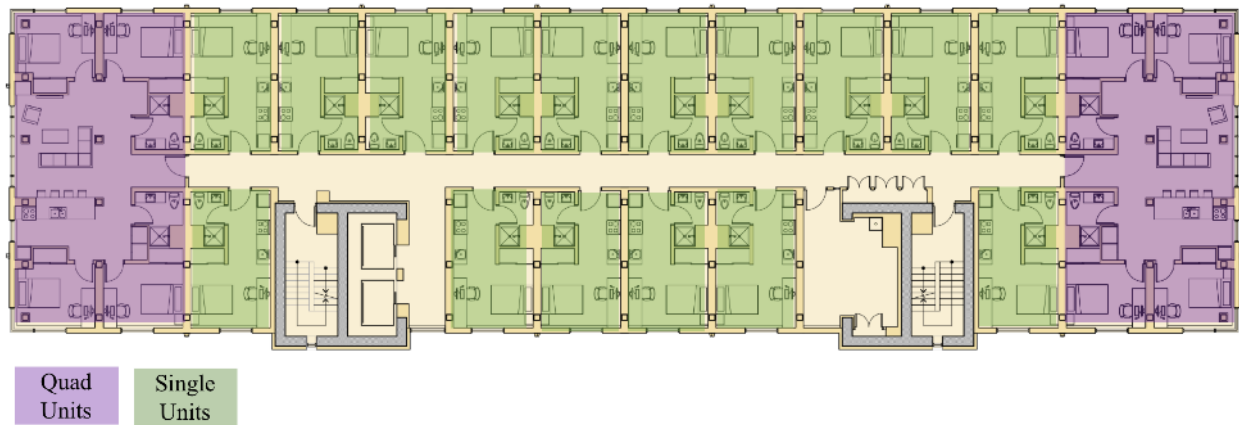

Figure 3-2 Typical floor layout (Courtesy of AOA)

The structural system was designed to be a hybrid solution as shown in Figure 3-3. The foundations, ground floor and first level, as well as the cores, are cast-in-place concrete.

The timber elements are in the levels 2 to 18 in the form of columns and slabs. The slabs are made 169mm cross-laminated timber (CLT) panels with a 40mm non-structural concrete topping. Most of the columns are standard GLT columns with a few parallel strand lumber (PSL) columns on the interior grids in the lower levels (2-5) for increased compression strength. The column to floor connection are steel assemblies, that are adhered to the columns with epoxy resin and bolted between each floor slab. Panel to core connections are steel angles bolted to the concrete walls and screwed to the panels.

Drag straps are installed at the cores and screwed to the panels at every level to tie the floor structure back to the concrete cores and transfer all lateral loading to the foundation through the cores.

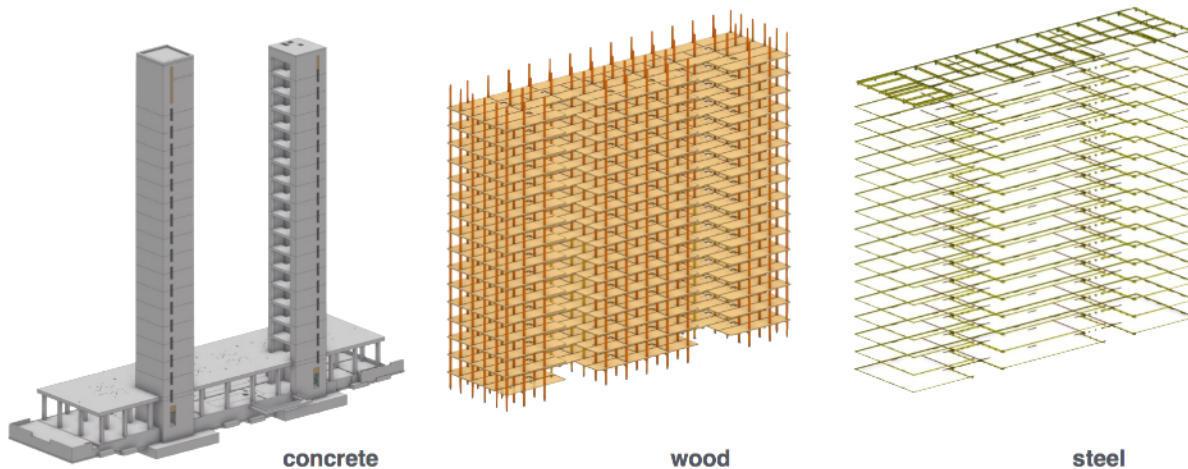

Figure 3-3 The various building materials used in Brock Commons (Courtesy of AOA)

The building is enclosed with a typical curtain wall system on the ground floor and a prefabricated exterior panel system on the remainder of the floors. The prefabricated envelope panels are insulated steel and frame assemblies that are on an exterior rain screen system. They were used to ensure rapid enclosure of the timber elements during construction, to minimize the exposure of the timber elements to weather (Figure 3-4).

The roof structure is metal decking on steel beams connected to the wood columns on the 18th level.

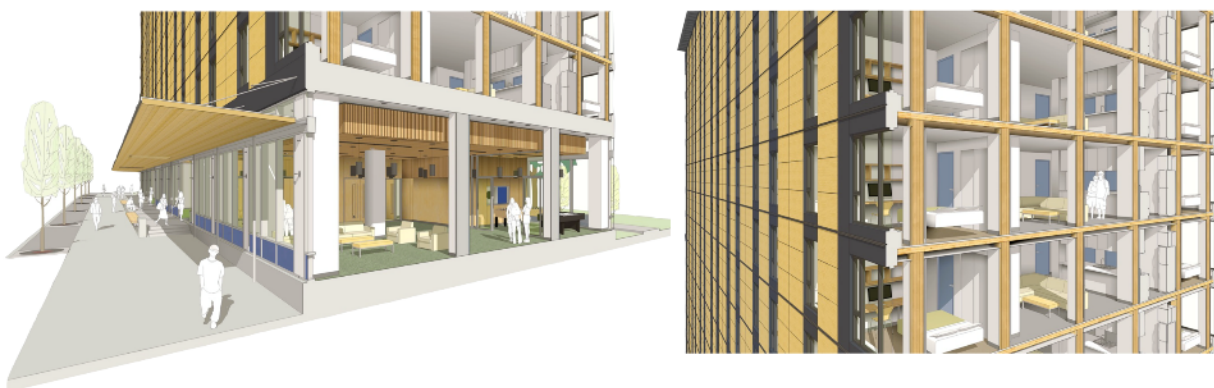

Figure 3-4 Building envelope panels and curtain wall system (Courtesy of AOA)

The overall structural system and the architectural design is viewed as being a very simple one by the project stakeholders, simplicity and ease of erection being one of the key drivers for this project.

The mechanical and electrical systems used in the building are fairly simple and standard practice. The challenges were to: 1. Minimize horizontal runs at each level as there can be no services cast in the slabs, 2. Coordinate all CLT penetrations ahead of slab production to cut out openings using CNC machines and 3. Ensure in case of a leak, the leak can be contained to the single unit it originated from. As will be discussed in detail later in chapter five This required the design workflow to accommodate a lot of collaboration and VDC was used extensively to fully virtually build the building ahead of time to ensure all details are fully coordinated as one example shows in Figure 3-5.

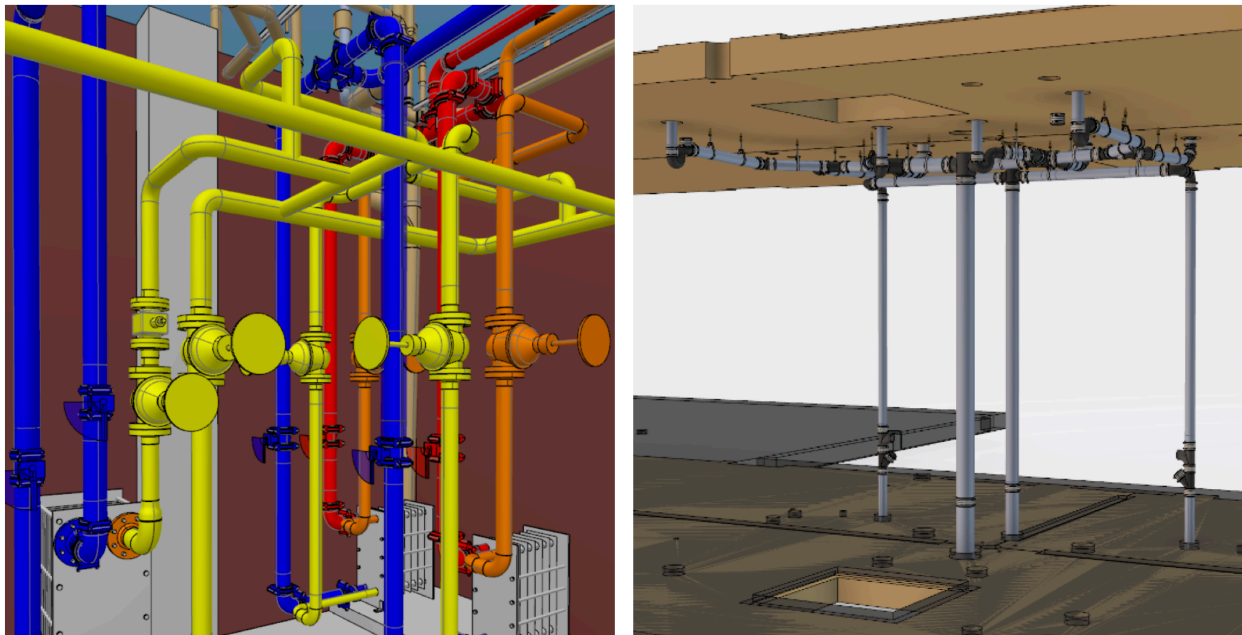

Figure 3-5 MEP coordination done in VDC to determine exact locations of penetrations and pre-fabricate mechanical room

3.2 Industry Context

The industry context was defined by the local Vancouver and Lower-Mainland Architecture, Engineering and Construction (AEC) industry. Throughout the Lower-Mainland, the preferred construction type for high-rises is identified as cast-in place reinforced concrete (Poirier et al., 2016).

Currently, use of wood is limited to 6-storey residential constructions with maximum height of 18 m, as elaborated in the latest British Columbia Building Code (BCBC year). These buildings are often light wood framed constructions and rarely use mass timber as in the mentioned height, there is no need, structurally, to use heavier MTPs. This lack of experience was a concern with the project designers, specifically the structural designer that voiced concerns about designing an MTP solution, but not having the technical and experienced trades available to implement it (Poirier et al., 2016).

There are, however, many turn-of-the-century buildings utilizing mass timber as the main building component around that could not be replicated today due to code constraints, but that are still performing and are fully habitable for the occupants. There are many such buildings in Vancouver including the Leckie and the Landing as illustrated in Figure 3-6 (Koo, 2013).

There are several constraints that account for the marginal use of MTPs in the construction industry. One of the main challenges for builders is regulatory concerns. As mentioned in the last paragraph, the BC building code currently does not allow for buildings above six storeys to be made with wood. In the case of UBC Brock Commons, a code consultant was hired to work with the province and develop a Site-Specific Regulation (SSR) to demonstrate the structural safety and soundness of the building to be issues a one-time permit to construct Brock Commons.

While the code has not changed yet, this building can serve as an example for others who want to pursue using mass timber, possibly for 10-12 storey market.



Figure 3-6 Left: The Landing, Right: The Leckie (courtesy of Citycaucus.com and fremarconstruction.com)

Another challenge for the adoption of the MTP into high-rise construction industry is the limited number of suppliers in North America. While BC has the most certified forests (for sustainable harvesting) in the world, the number of major engineered timber suppliers is limited to seven in all North America, and effectively only one that can service BC (Poirier et al., 2016).

The limited number of suppliers means a small supply network which causes problems for sourcing and procuring MTPs on a mass scale. Additionally, it discourages competitive pricing and unless a price competitive timber solution can be used by builders, they will tend to stay clear from using timber.

3.3 Business Context

The project was selected as one of the three demonstration projects by Natural Resources Canada (NRCan) and Canadian Wood Council's (CWC) in 2013. The demonstration project identified building projects in Canada that could demonstrate the commercial viability of innovative wood building solutions in high-rise construction. Their overall aim was to demonstrate, both

physically and fiscally, the applicability and replicability of wood construction in the high-rise construction. The building had to be safe, structurally sound, functional, highly livable, and financially competitive. The project also aimed to revolutionize the use of wood and mass timber products in British Columbia and foster the adoption of wood construction for future mid- and high-rise buildings, elucidating the structural as well as sustainable benefits of wood with comparison to other building materials. The selection of Brock Commons Phase I by NRCan and CWC ensured the viability of the wood portion of the project (CWC, 2013).

There were a number of incentives for both the provincial government that backs this project up through funding and grants and for UBC to take on the challenge of building the world's tallest hybrid timber building that are:

3.3.1 For British Columbia

With 52 million hectares of certified forests, BC has more certified forests than any other jurisdiction in the world, second only to Canada as a whole. The certifications used in BC are the Canadian Standards Association's Sustainable Forest Management Standards (CSA), the Forest Stewardship Council (FSC) and the Sustainable Forestry Initiative (SFI). Certified forests are ones in which sustainable forest management measures are implemented. BC is recognized as a global leader in sustainable forest management practices and with 95% of its forests being public owned, the priorities of land use are developed through community based consultations. A 2016 customer market acceptance research conducted by the Forest Products Association of Canada (FPAC) found that *"97% of those that expressed an opinion, have a positive impression of how Canadian forests are managed. Their perception of British Columbia's forest management was similarly extremely positive. B.C.'s score was highest among North American, Chinese, Japanese and Korean companies. The professionals surveyed also positively evaluate Canada's*

performance on environmental issues. The most positively perceived attributes are related to legality assurance and forest management practices.”(FII, 2016)

As BC is capable to maintain sustainable harvesting practices while providing large quantities of timber to the global market, penetrating the construction market provides BC with further economic growth opportunities. The availability of government grants and NRCan’s EOI are further indications that the local and federal government are interested in investing in demonstration projects to promote wider use of timber in mid-rise and high-rise construction. Wood is a natural insulator, it is lighter than traditional building material and certain properties (such as fire performance) have the potential to outperform the traditional building material.

3.3.2 For UBC

This building is one of the five mixed use and student housing commons and part of the 2010 UBC Vancouver Campus Plan to address the growing need for student housing on campus. As of 2015, 6,000 students were on the waitlist to get student housing, and according to an article published on UBC news, SHHS is aiming to provide over 2,000 beds by 2017 with an additional 640 by 2019 (UBC Public Affairs, 2015).

As this building is part of the UBC’s response to the student housing need on campus, through attending various workshops and lectures given by UBC representatives, as well as conversations and research into UBC values, goals and ambitions, the author of this research has identified the main drivers for pursuing Brock Commons as follows:

1. **Cost:** Since UBC is a public entity and any additional cost to the construction would mean the students would have to take on the additional cost, one of the main drivers was ensuring regardless of the structural solution developed, the building is price competitive with campus’s standard practice which is building with concrete. The availability of

nearly \$4.5M worth of grants available for using a timber solution (Table 3-1) was the reason this option was pursued as any “Timber premium” could potentially be covered using the grants. These grants added up to approx. 8.6% of total project cost at the time of planning.

Table 3-1 External funding available for a timber solution (Poirier et al., 2016)

Funding Source	Amount
Natural Resources Canada (NRCan) contribution for Tall Wood premium	\$2,335,000
Binational Softwood Lumber Council (BSLC) contribution for Tall Wood premium	\$467,000
Forest Innovation Investment (FII) contribution for Tall Wood Premium	\$650,000
Further Gov’t Targeted Fundraising for Tall Wood premium	\$1,000,000
Total 3rd party funding provided	\$4,452,000*

2. **Fire and Life Safety:** As the building is meant to house students, ensuring safety is of utmost importance to UBC. Any real or perceived risks to safety were to be addressed in detail to ensure the project can demonstrate safety both in performance and in the construction process.
3. **Optimal Layout:** UBC has developed an optimal floor layout for studio and quad units which is the layout used for UBC’s Ponderosa Commons Phase II. For the foreseeable future, any new development for student housing would follow that as a precedent and will have a very similar layout.
4. **Construction Speed:** Due to the high volume of demand, any new construction should aim to minimize the design and construction phase durations. Therefore, use of pre-fabricated and novel construction processes are preferred. A mass timber building provided extended pre-fabrication and fast-tracking opportunities.

5. **Sustainability and UBC as a Living Laboratory:** UBC mandates a minimum gold LEED certification for any new development on campus. The timber building was expected to hit the same targets. Additionally, using a novel construction material provided UBC with the opportunity to monitor the building for research and academic purposes
6. **Media Attention:** While not necessary a priority, this project has brought plenty of eyes and attention to UBC which is helping promote UBC's brand.

3.4 Site Context

UBC Vancouver campus has mandates for all new building on campus and in the “Design Guidelines” adopted in 2010 which are listed below (UBC Campus and Community Planning, 2010):

- Sustainability
- Universal Accessibility
- Architectural guidelines such as:
 - Positioning, Massing, and Setbacks
 - View Corridors
 - Building Heights
 - Architectural Expression



Figure 3-7 Brock Commons site (Courtesy of AOA)

Brock commons is classified as a “Hub” on campus based on the descriptions in the campus plan (Figure 3-7). *Hubs* are defined as “*local mixed-use centres distributed around campus that accommodate significant student housing, plus academic support services open to all faculty, students and staff. These hubs will function as neighbourhood ‘living rooms’ for the daytime community of surrounding academic disciplines as well as for the students who reside there. The open space associated with each hub will be informal and busier than the academic commons due to the mixed-use daily program that hubs will include.*” (UBC Campus and Community Planning, 2010)

3.5 Design Process Summary

The design and pre-construction process for Brock Commons officially commenced in November 2014 and was completed in September 2015. The building required approval from UBC Board of Directors for budget, the owner for design and Authorities Having Jurisdiction (AHJ) for code and building permitting (Poirier et al., 2016).

The team had eight months to design and get approval for the entire project. To accomplish this, they relied on different strategies (Poirier et al., 2016):

- Using a strong precedent that had been already built on campus

- Well defined project constraints
- Conducting integrated design workshops
- Using a design approach akin to set-based design
- Heavy involvement of the virtual design & construction integrator for planning and constructability review
- Building a full-scale mockup
- Involving AHJs throughout the design process

From the beginning, the team wanted to ensure that the uniqueness of the building be contained to a manageable scope, and insure overly ambitious plans would not result in the failure of the project. According to the construction management's agent, the approach was "the structure would be substantially unique, the envelope would be somewhat unique and the interior finishes would be relatively typical". This required a cyclical process that would propose a structurally sound system, conduct cost analysis and change the system to ensure economic feasibility (Poirier et al., 2016). To facilitate this process effectively, a 3-day workshop was held early in 2015 with the presence of the owner, architect, structural engineer, code consultant, construction manager (in an advisory role), virtual design and construction integrator, wood erection and concrete trade (in a design-assist role). The team discussed various structural strategies and worked collaboratively to keep the budget to a target of 192\$/ft². This number at the time had come from using another one of UBC's new built concrete residential buildings as a baseline, to demonstrate economic viability for Brock Commons. This was made possible by the use of rapid digital prototyping offered by the VDC integrators that created quantity take-offs, and together with the experience and knowledge present in the room, allowed for rough, but reliable budget estimations (Poirier et al., 2016).

During this time, the project constraints were identified in the workshop which is displayed in Figure 3-8 and are categorized into site/design related constraints, Material constraints, production constraints, shipping constraints and installation constraints.

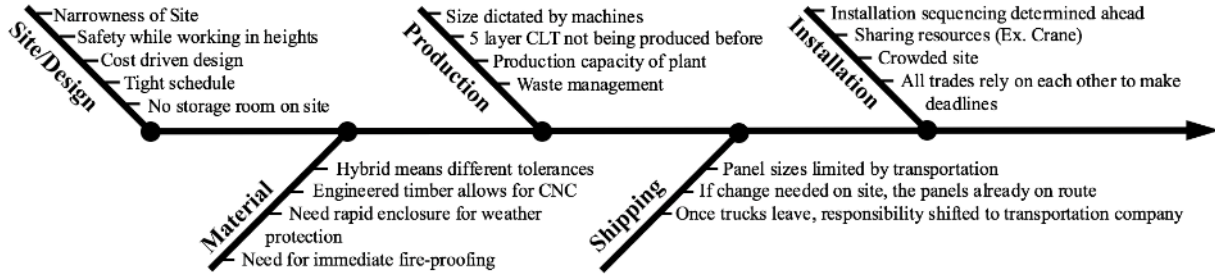

Figure 3-8 Constraints in pre-fabrication

While 3d and VDC models are not an official requirement as project handover documents, a key strategy has been to transfer the digital models (validated by the engineer on record) directly to the pre-fabricators (floors, columns, envelope panels) along with the official 2D drawings.

Figure 3-9 highlights the handoffs between the structural engineer, the VDC integrator and the mass-timber supplier.

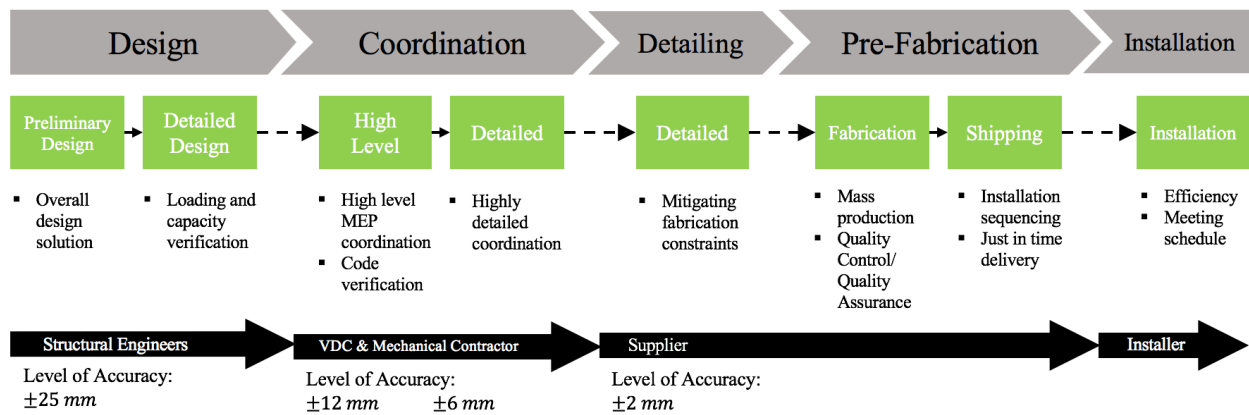

Figure 3-9 Hand-off, constraints, responsibility and tolerances process map

It was the UBC PT project manager's strong opinion that a full-scale mock-up of the building be built somewhere offsite, to test and validate decisions such as: connection details with column and slab, connection with the slab and concrete core and confirm the choice of steel assembly for the structural columns. It also was a test of the shortlisted companies for the pre-fabricated envelope panels to bring a sample panel and test the installation ease and precision on site before being awarded the contract. The mock-up with the floor panels, columns and envelope attached is pictured in Figure 3-10.



Figure 3-10 View of the mockup with one type of prefabricated panel

Chapter 4: Methodology

In undertaking this research, a literature review was conducted and the main deficiency and gap in knowledge was identified to be a comprehensive case study of a tall timber building, highlighting various design and construction nuances that are attached to utilizing an unconventional building construction material. In the context of this building, there were innovations in both the final product with construction strategies and prefabrication and in the process with the extensive use of VDC which formed the two main SOs of this research as highlighted in Table 4-1.

After the SOs were identified, specific research activities were assigned to each and chronological sequencing of the mentioned activities were established as illustrated in Table 4-1 and Figure 4-1. Later each research activity was conducted using specific data collection methods further elaborated in the chapter in Table 4-2. This chapter will describe each research activity and their corresponding data collection and analysis methods.

Table 4-1 Research activities for each sub-objective

RO: Identifying innovations used in the construction of a mass timber high-rise project	
SO 1: Document and Analyze the project innovations	
	RA1: Investigate project background to highlight drivers and contexts
	RA2: Identify current construction practices to highlight fields of innovation
	RA3: Investigate Owner perceptions of building with timber to identify expectations
	RA4: Investigate Designer perceptions of building with timber to identify expectations
	RA5: Examine project documentations to track design process steps
	RA6: Examine project documentations to track construction process steps
	RA8: Track construction progression to identify accordance with planned strategies and schedule
	RA9: Identify Constraints and Lessons Learned specific to Brock Commons
SO 2: Document and Analyze the innovative uses of VDC	
	RA2: Identify current construction practices to highlight fields of innovation
	RA5: Examine project documentations to track design process steps
	RA6: Examine project documentations to track construction process steps
	RA7: Track the VDC model evolution to identify model development process
	RA9: Identify Constraints and Lessons Learned specific to Brock Commons

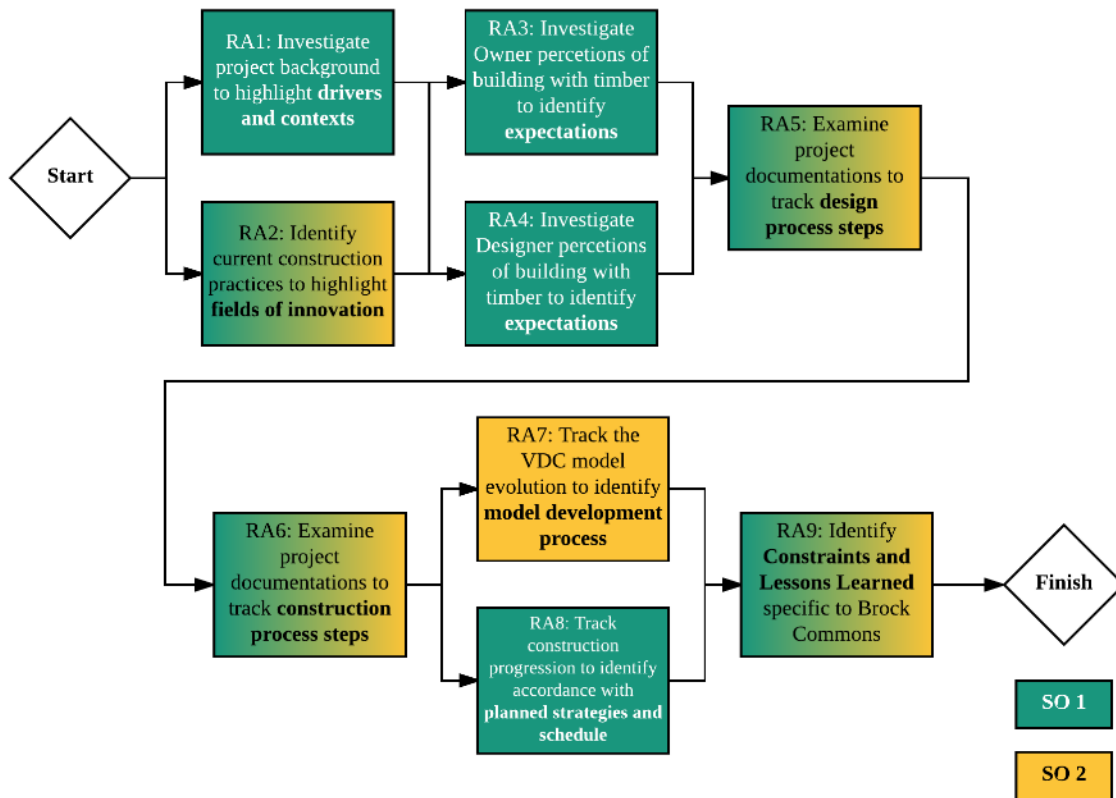

Figure 4-1 Research activity sequence and roadmap

4.1 Research Activities

Nine research activities were designed to assist in forming a clear response for the selected SOs. The research activities required a mixed–method data analysis of both qualitative and quantitative data analysis. The following sections describe each research activity in greater detail and elaborate on data collection and analysis that followed:

RA1: Investigate project background to highlight drivers and contexts

During this part, the main task was to gather as much background information about the project as possible to identify motivations, drivers, goals and expectations for the project from the different project stakeholders. During this time, the majority of the information was obtained

through the comprehensive interviews conducted with the design team, the owner, the construction team and the VDC integrators. The mentioned were all participants in the initial discussions and talks before the project was formally approved by the UBC board of directors, and working collaboratively to ensure the expectations and goals of the owner can be met in all aspects of budget, schedule and building safety and operation. The interview questions were designed ahead of time to provide structure for the session, however, during the first round of interviews, the goal was to capture as much of the motivations, goals and drivers for the interviewees as possible. Hence the questions were kept to a minimum, and the participants were allowed to elaborate on factors and issues they found to be the most important, as the goal for the research activity was to identify the project context from different perspectives and carve out project drivers.

The interviews were transcribed and coded, to allow for identification of recurring themes and concepts that led to the identification of areas of concern, projects drivers and risk categories the participants were willing to reasonably take on.

At this point, the researcher was also given access to the project documentation from the construction managers, and since they were involved with the project from the very early conception stages, many of the communications and preliminary design documents were made available. A rigorous study of the team communications and findings were conducted to gain insight on the selected design, along with the issues and complexities associated with it. Finally, independent research on typical construction methods, constraints on working with timber, other tall timber precedents and their proposed solutions were conducted to help identify areas of innovation and novel construction methods.

RA2: Identify current construction practices to highlight fields of innovation

Building on RA1, the next step to aid in highlighting innovation was to gain a deepened understanding of the standard practices and typical construction methods globally and in the Lower Mainland. This was done both through academic and industry literature reviews, conversations with professionals in the field and continual communications with the project team. As this was a continuous process throughout the entire duration of the research, questions relating to this were included in the second round of interviews, specifically when conducting the weekly meetings with the site senior project manager, as will be further elaborated in section 0. Additionally, as the pre-fabrication of the building elements started, and site visits to the facilities were conducted, the pre-fab practices were captured to be compared with on-site construction methods.

In general, the data analysis of this phase was a very qualitative one, mostly focused on identifying how this project was overcoming challenges relating to the use of a new construction material (wood) and the challenges in modifying the construction process to allow for more off-site construction.

RA3: Investigate Owner perceptions of building with timber to identify expectations

At this stage, the goal was to get a clear understanding of what the expectations for collaboration of the team, the construction schedule, the project cost and building performance were from the owner's point of view. This information was important as expectations drive the project team conduct and have a direct effect on the final product. Due to its novelty in both the process and product, this building has been the focus of many workshops and seminars, as well as lectures and presentations, and those were all captured to paint a holistic view of what the public is expecting from this project, and what the owner wants to put further emphasis on. One of the main challenges in using and advocating the use of timber in high-rises are public perceptions of

timber and the marketability of the final product. These concerns and drivers were captured and are presented in section 3.3 and specifically in section 3.3.2 of this thesis.

Similar to the last two research activities, the data analysis was a very qualitative one, that focused on extracting patterns and groups of concerns and drivers for the project.

RA4: Investigate Designer perceptions of building with timber to identify expectations

Once the owner's perceptions and subsequently their expectations were established, it was important to also capture the issues and constraints the designers and the overall project team were anticipating with the building. Similar to RA3, these were captured through further interviews and conversations as well as both attending and reading meeting minutes between the various stakeholders where concerns were voiced and addressed.

Once these perceptions and expectations were identified, they were used to drive the subsequent activities in examination of the project documentations, to examine whether they were reflected in the designs, site instructions and construction strategies.

RA5: Examine project documentations to track design process steps

Once RA1-4 were done, the goals, motivations, concerns and strategies to address all the mentioned were established. With that, the goal of the next research activity, RA5, was to begin capturing the design process in order to carve out innovations in the subsequent steps. In doing so, the project documentation was closely examined and monitored to identify any decisions or considerations that directly related to the use of timber or prefabrication for the project. These documents included plans and drawings, meeting minutes, site instructions, specifications, shop drawings and installation strategies.

Additionally, all documents relating to the VDC modeling was examined to determine 1.the types of information in the final model, 2.the frequency of updates in the model and 3.the types

of output the model was producing for the design team that was later fed into the subsequent design steps.

Some quantitative data analysis was done for this stage, such as tracking the number of RFIs the VDC integrators sent to the team, their response time and the frequency over time. However, as the focus of this research was not to conduct an in-depth RFI and issue analysis of the Brock Commons project, that information was used to inform the author's understanding of the types of communication, types of recurring issues and how they were mitigated.

RA6: Examine project documentations to track construction process steps

Similar to RA5, this step was done to capture the innovation in the construction process. During this step, the relevant construction documents were analyzed to identify recurring issues and monitor the risks identified in the earlier stages. During this stage, through continued communication with the construction team, interviews were conducted weekly to identify successes, short comings and the anticipated bottlenecks and constraints for the next week. These information as remedial work that would have been required were captured and the relevant documentation were collected to inform the analysis of the construction process.

Same as RA5, some quantitative analysis was done to further inform the understanding of the types of issues and mitigation strategies.

RA7: Track the VDC model evolution to identify model development process

This activity was done by utilizing the VDC integrator's internal documentations that illustrated the latest changes in the model, the latest communications with the project team and their responses. The collected data was divided into phases covering the preliminary design to construction phase, and the role of the VDC in each of the phases were highlighted with respect to the inputs, products and outputs.

Additionally, issues in modeling and communication were captured through additional interviews with the VDC integrators other project team members. This activity was done mostly with qualitative analysis methods by tracking the changes and updates.

RA8: Track construction progression to identify accordance with planned strategies and schedule

This was what the bulk of the research time was spent on, as it required the author be present on site an average of 2-3 times a week during the construction of the building elements that were previously identified as containing innovative building practices. During this time, on top of personal visits to site and recording of observations, photos and videos, 2 time-lapse site cameras were installed by a UBC research team and the owner to monitor the construction progress on site.

During this time, regular meetings and interviews with the construction manager were conducted to capture all aspects relating to the construction processes including issues, unique construction strategies and workaround techniques to mitigate potential risks to the construction safety and material protection. A pre-determined set of questions were asked from the project manager with each visit, that included the following questions:

1. – Is the Project on Schedule?
2. – What has been going well this week?
3. – What didn't go well this week?
4. – Any interesting/noteworthy remarks about the past week?
5. – What is planned for next week?

The recorded responses were compared with project documentation such as schedule, specifications and construction strategies to separate personal opinions and minimize the bias of the project manager from the facts.

During this phase, site visits to the pre-fabrication plants were conducted and their fabrication and assembly line was recorded to complete the overall construction strategy and process.

RA9: Identify Constraints and Lessons Learned specific to Brock Commons

Once a detailed picture for SOs one and two were drawn, and before any conclusions were drawn by the author, further measures were taken to extract every lesson learned and any constraints identified by the project team. These efforts included attending wrap-up meetings, seminar and workshops where the project team make comments on the completed sections of the building and the workflows. Finally, meeting minutes, project communications and initial goals identified in the earlier research activities were overlaid with the recorded performance to highlight any conflicts, unfulfilled promises or identified risks. This information will be used to inform future project teams better anticipate the issues and constraints they can expect in building a tall wood building.

Table 4-2 identifies in detail the various data that were used in all the research activities described earlier:

Table 4-2 Data collection per research activity

Data Type	Data Analysis	Data Collection	RA 1	RA 2	RA 3	RA 4	RA 5	RA 6	RA 7	RA 8	RA 9	
DC1	Qualitative	Conducted, Recorded, Coded, Categorized, Summarized	Interviews									
			Design Team	X	X	X	X					X
			Owner	X	X	X	X					X
			Consturction Team	X	X	X	X					X
			VDC Integrator	X	X	X	X			X		X
										X		
DC2	Quantitave	Reviewed, Examined, Repetative and one-off elements Identified	Project Document Review									
			Plans and design Documents	X				X	X			
			Meeting Minutes		X	X	X	X	X			X
			Specifications		X			X	X			
			X		X	X	X	X	X	X		
DC3	Quantitave	Reviewed, Examined, Patterns Identified	Fabrication Document Review									
			Shop Drawings					X	X		X	
			Site Instructions		X			X	X			
						X	X	X	X			
DC4	Qualitative	Photos, Videos, Informal Q&A	Site Visits									
			Timber Supplier Facilities		X			X	X		X	
			Envelope Panel Facilities		X			X	X		X	
			X	X		X	X					
DC5	Qualitative/ Quantitative	Observations recorded, photos, videos, Q&A with site personel, Progress checked against Schedule	Progress Tracking on Site									
			Site check-ins					X	X		X	
			RFIs					X	X		X	
			COs					X	X		X	
			Site Camera					X	X		X	
				X	X	X	X	X	X	X		
DC 6	Qualitative	Note taking, Coding, Categorizing, Summarizing	Gathering Industry and Academic Opinions									
			Attending Conferences			X	X					
			Attending Workshops			X	X					
			Attending Lectures			X	X					X
			Independent Literature review	X	X			X	X			
			X	X		X	X			X		
DC7	Qualitative/ Quantitative	Downloading and organizing data, Monitoring model evolution, Identifying recurring issues	Progress Tracking of the VDC Model									
			VDC Integrator communications							X		X
			Model Evolution					X	X	X		
			VDC Integrator Questions							X		
						X	X	X				

Chapter 5: Project Innovations

As mentioned earlier, in this chapter, each of the building elements will be described in detail to fully capture the innovative process in the design and the innovative construction strategies. The descriptions include a timeline description of each building element and a comprehensive analysis of the product and construction processes of each building element. For each section, the process flow table is color coded to highlight “points-of-interests” which document the special considerations and/or processes that were utilized for the completion of that section as well as “challenges” and “constraints” the construction team had to overcome and what takeaways they had regarding that specific building element.

5.1 Concrete Cores

Construction and Product Description

The work for the construction and pour of the two free-standing concrete cores housing the janitor’s closet, stairs and elevators began on March 10th, 2016 and lasted for approximately four months, ending in June 4th, 2016.

The concrete cores form the “backbone” of the UBC Brock Commons. They provide the rigidity that is required to support wind or seismic lateral forces exerted on the building. They also provide the vertical circulation, housing both the stairs and the elevator shafts, as is common with high rise construction. The core walls are 450 mm thick cast-in-place reinforced concrete. They form a continuous element from the foundation to the roof to which each level is attached. To “lift” the cores, the project team used specialty products such as the “Lift N’ Lock Platform” system for pouring the concrete(Figure 5-1). The system, illustrated below, was modified from the typical single height configuration to a double height one to increase the efficiency and accuracy of the pours. The system includes a Lift n’ lock safety platform for workmen as well as

an outside form and an inside form box. There are side-platforms for workmen to work on the outside of the cores.



Figure 5-1 the lift n' lock system, (Courtesy of Aluma Systems)

The rebar and concrete schedule for the cores are typical, however they were designed to the seismic provisions of the 2015 National Building Code of Canada (NBCC, 2015) which are more rigorous than the previous versions. That means there are more reinforcement used inside.

Concrete Core Process Description

The inner core boxes, the outside wall panels, the safety platform, and the work platforms are all prefabricated and bought from the Aluma Systems and assembled on site by the concrete trade (Figure 5-2).

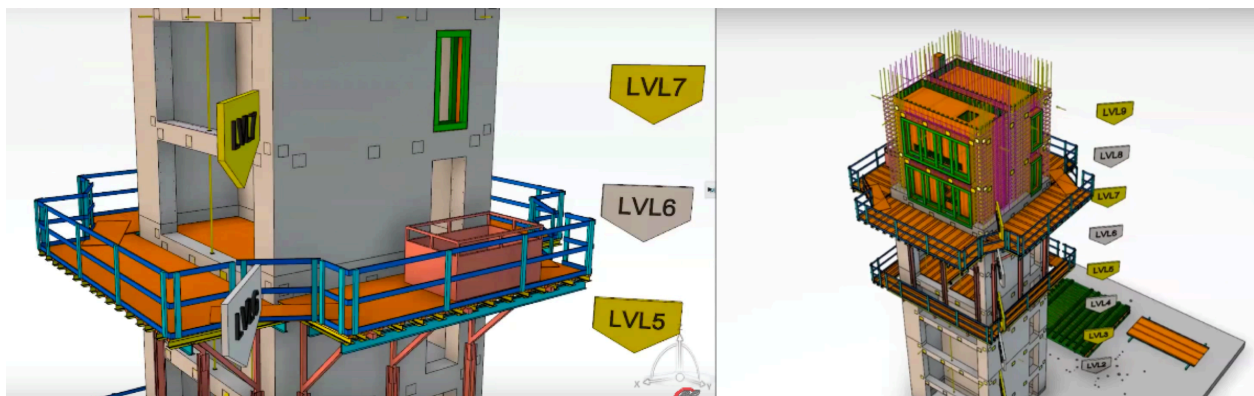

Figure 5-2 The work platforms for workmen and core boxes (Courtesy of CadMakers Inc.)

The concrete core construction for two floors on each of the cores is a 5-day cycle as elaborated in **Error! Reference source not found.** Figure 5-3 and in a VDC video (snapshots shown in Figure 5-2), with slight modifications such as minor changes in the illustrated steps and changing sequencing of subtasks, based on discussions at the trade meeting where this was shown.

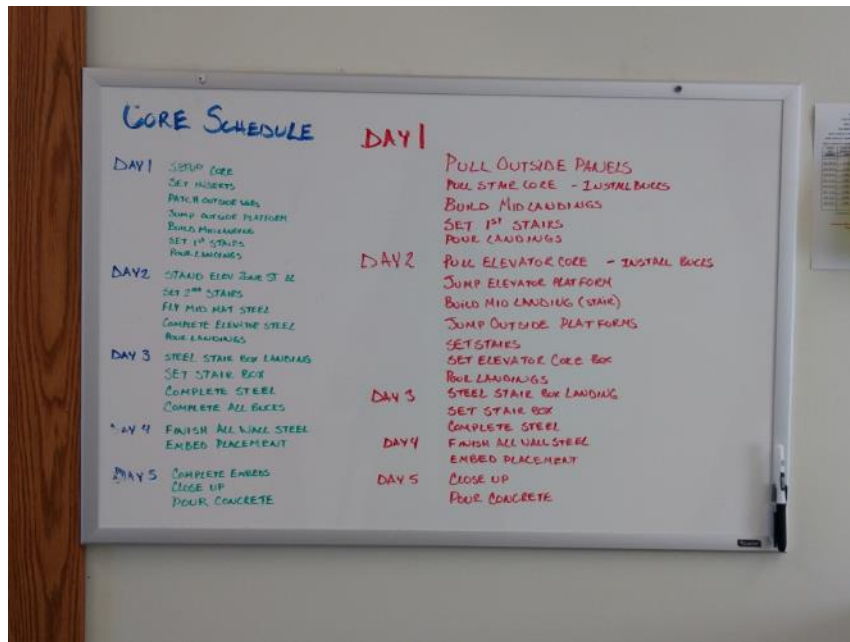



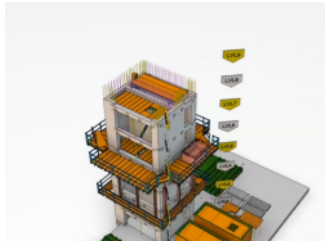

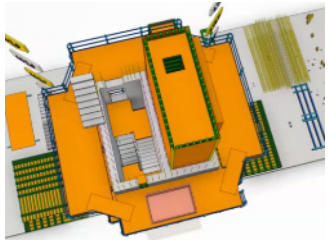

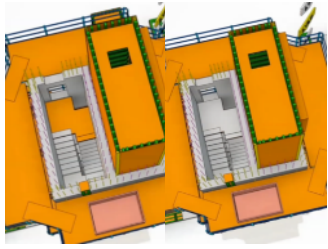

Figure 5-3 Concrete core schedule for the two cores, picture taken at the site trailer





Table 5-1 illustrates each step involved in the process along with pictures and comments. The comments in blue denote lessons learned, the ones in green show a point of interest and the purple demonstrates any challenges or constraints the team faced:

Table 5-1 Concrete core process flow

Day ID	Activities	Photos	Comments	Image Credit
Day 1	Strip core button up (exterior forms)		The Aluma Lift'n Lock system which was modified to be double height for the construction schedule acceleration and increased accuracy.	Azadeh Fallahi

Day 1	Set inserts for outside decks		It was typical on the project to work on Saturdays, and usually it's harder to get labour to show up to work on the weekend. The geographical location of UBC and it being far from city centers added to the difficulty of commute for labour.	Urban One Builders
Day 1	Patch tie holes outside walls			
Day 1	Jump outside platforms (4decks)			
Day 1	Strip stair box		One set of the core boxes arrived on site eight weeks late. But since there was a learning curve and after four cycles on each core, the 5-day cycle was met (it started with 7-8 days initially). Since there were allowances built into the schedule, this didn't affect the overall construction time.	Azadeh Fallahi
Day 1	Strip elevator box			
Day 1	Add temporary opening support for elevator openings		-	Urban One Builders
Day 1	Jump inside elevator platform		This is a general comment, but windy days would result in crane stoppage, and since the schedule critical path included the cores to be finished, that could have been problematic.	CadMakers Inc.
Day 1	Build stair mid landing		The stairs were pre-cast on site, and lifted and placed inside the cores using the cranes. The landing was poured in place.	Azadeh Fallahi
Day 1	Set elevator box	-	-	
Day 1	Sprinkler canning in divider wall	-	-	
Day 1	Fly first set of stairs to mid landing		The decision to pre-cast the stairs on site proved to be the best choice, as it allowed the construction to proceed with greater speed.	CadMakers Inc.
Day 1	Fly second set of stairs to top landing			

Day 1	Fly elevator pour platform	-	-	
Day 1	Temporary platform for divider wall work		-	
Day 1	Reinforce landings		A slip form could not be used, since the access to the core is from the inside (using the stairs) and that, the window openings were not possible with a slip form.	CadMakers Inc.
Day 1	Pour landing at stairs			
Day 2	Strip/build stair landing	-	-	
Day 2	Sprinkler canning in divider wall	-	-	
Day 2	Stand elevator steel		-	Azadeh Fallahi
Day 2	Fly in third set of stairs to mid landing		The stairs had to be poured concurrently with the core going up, as it was used to access the core from the inside while working	Urban One Builders
Day 2	Fly in fourth set of stairs to top landing			
Day 2	Reinforce landings			
Day 2	Complete all steel on elevator side	-	-	
Day 2	Concrete for both cores (stair landings precast)	-	-	
Day 3	Complete reinforcing to divider wall	-	-	
Day 3	Prep elevator platform pockets and install stair ledgers	-	-	
Day 3	Set stair box	-	-	
Day 3	Layout and complete door bucks		The door bucks were initially being built for each floor, but upon further discussions it was decided to prefabricate them to increase efficiency.	Urban One Builders

Day 3	Complete all steel on elevator side			
Day 3	Insert sprinkler sleeves			
Day 3	Complete all bucks			
Day 4	Finish all wall steel		-	Urban One Builders
Day 4	Embed placement (done by the concrete trade)		One of the main lessons learned from the concrete portion was that with adequate QA/QC, even tighter tolerances can be achieved using typical construction methods. The concrete was given up to +/- 50mm of tolerance, but ended up being very flush and was accurate to +/- 20mm in the cores. That is partially due to the double height formworks which made it easier to maintain that margin.	Azadeh Fallahi
Day 4-5	Close core forms		Concrete is generally 1" tolerance in any direction over one level and in this project, concrete up to 2" out on a level was observed. This could be further analyzed to work to an even tighter tolerance in the next project.	Urban One Builders
Day 5	Pour concrete		The core was finished ahead of the arrival of timber, since there were no room for an additional crane on site to facilitate parallel operations taking place.	Azadeh Fallahi

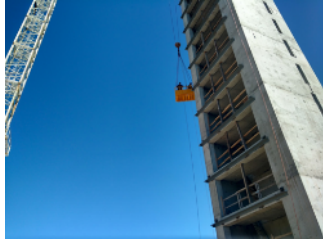
After Core Completion	Welding l-angles		The welding of L angles was done ahead of wood structure both to ensure no hot work was being performed near timber and to meet the schedule since welding accurately is a time intensive process that would delay timber erection since the pace is much slower than the planned timber element installations.	Azadeh Fallahi
-----------------------	------------------	---	---	----------------

5.2 CLT Slabs

Construction and Product Description

Entire production time for the timber floors and columns was roughly two months (9 weeks) for the entire building including columns, connection steels and CLT.

The installation of the CLT panels took nine weeks and half, beginning on June 10th, 2016 and lasted till Aug 9th, 2016.

The CLT panels are a 5-layer panel and 169 mm thick. The panels have 1650 Machine Stress-Rated (MSR) lumber placed in major strength layers (top and bottom layers) instead of #2 and better lumber as CLT must be a balanced layup. The products are PRG 320 (APA, 2011) certified by The Engineered Wood Association. PRG 320 is their latest standard and is used by all engineered wood manufacturers.

There are four different panel sizes:

- 6000 X 2850 mm
- 8000 X 2850 mm
- 10000 X 2850 mm
- 12000 X 2850 mm

The CLT panels is oriented on the building's long axis and installed in a staggered configuration as shown in Figure 5-4. There are 29 panels per level. They come in four different lengths,

spanning one and a half (located at the cores, 6 m long – two panels), two bays (8m long – 19 panels), two and a half bays (located at the cores, 10 m long – two panels) or three bays (12 m long – six panels). On the short axis, panels are 2.85m wide. The CLT panels are joined together using a 140mm x 25mm thick plywood spline that is both nailed and screwed to each panel.

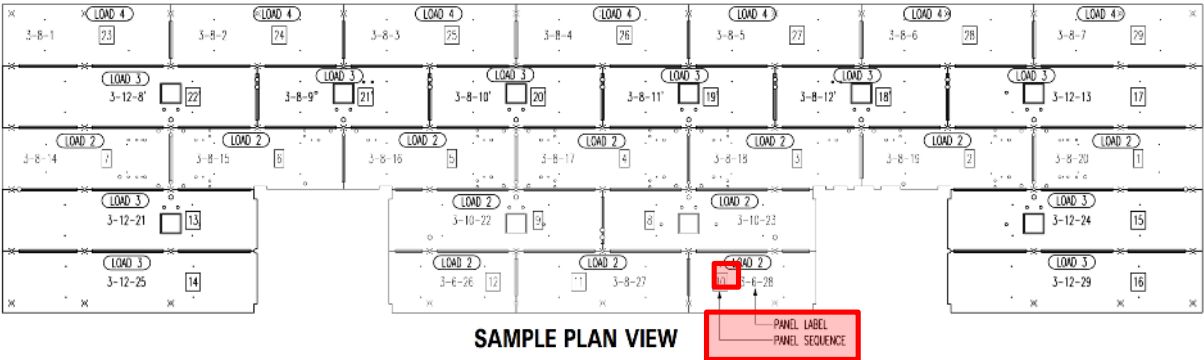

Figure 5-4 Installation sequencing (as highlighted in red) (Courtesy of UrbanOne Builders)

Fabrication and erection tolerances are as follows:

- Fabrication:
 - Thickness: +/- 1.6mm
 - Width: +/- 2mm
 - Length: +/- 2mm
 - Squareness: The length of two panel face diagonals measured between panel corners shall not differ by more than 2mm.
 - Straightness: Deviation of edges from a straight line between adjacent panel corners shall not exceed 1mm.
- Erection - Floors and Roofs:
 - Elevation: +/- 2mm from theoretical.



Miralite is the recommended sealer by the manufacturer to be applied to the CLT panels to





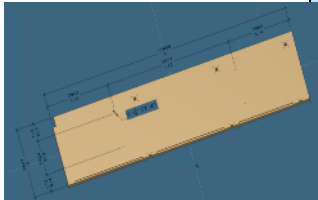

mitigate issues caused by exposure to adverse weathers. Before the acoustic concrete is poured, another sealer, the Thomson Water Sealer is applied to the CLT to prep the surface further for concrete on top of the Miralite applied at the plant.

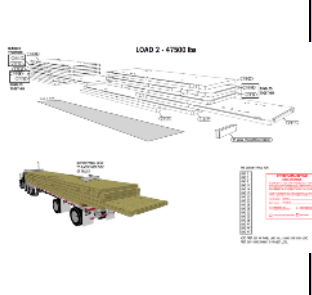

CLT Process Description

Table 5-2 illustrates each step involved in the process along with pictures and comments. The comments in blue denote lessons learned, the ones in green show a point of interest and the purple demonstrates any challenges or constraints the team faced.

Table 5-2 CLT process flow

Phase	Activities	Photos	Comments	Image Credit
Prefabrication	The lumber pieces are pressed together in opposite directions every layer in the CLT press	-	-	
Prefabrication	The VDC integrator sends the suppliers a simplified 3d model that includes all dimension details required for the production. The supplier then alters the model to fit their own software and make modifications necessary to achieving the tight tolerances.		The VDC integrator used a .stp export of their model (a .stp file is a simple geometry file format) and sent it to the supplier. For the mockup, the VDC integrator produced all the shop drawings, however it was later decided that the workflow would be more streamlined the shop drawings were developed by the timber suppliers.	CadMakers Inc.
Prefabrication	The CLT panels are cut into specified shapes using the CNC machines (the CNC including machines cut all the openings for MEP)		One of the main challenges and constraints was meeting the tight mandated tolerances. Tolerances for CLT were +/- 2 mm in all dimensions. This was unilaterally applied, whereas the suppliers have specialty tolerances for different framing types. Anything that was unique was considered and ok'd with the engineer on record (EOR) if it did not meet the flat blanket specs	Azadeh Fallahi
Prefabrication	The cut panels have 1 layer of sealant applied to them to partially protect them against weather		The sealer was "Miralite" as recommended by the manufacturer. While the sealer performed as desired, the nature of CLT panels and the existence of "slits" along the lumber pieces makes the CLT very porous. This is further discussed in the water management section.	Azadeh Fallahi

<p>Prefabrication</p>	<p>Once dry, the panels are wrapped in weather proof packaging</p>		<p>The team could achieve the tolerance through intense and rigorous QA and QC from the manufacturer. During installation, every single installed panel had to be checked using laser measures to ensure maximum accuracy can be achieved.</p>	<p>Azadeh Fallahi</p>
<p>Prefabrication</p>	<p>The wrapped panels are loaded on the trucks in the reverse order of installation and ready for shipment (each floor is 29 panels and three truck loads)</p>		<p>A challenge in shipping the panels was that since the panels were being delivered on site 11 hours apart, if an issue was discovered while installing the panels, there was no contingent time to remedy the situation on site, and due to the tight site, there would have been nowhere to store the next arriving shipment.</p>	<p>From Supplier Shop Drawings</p>
<p>Installation</p>	<p>The trucks arrive a few hours apart to the site on the day of the installation. The trucks are loaded in reverse order of installation</p>		<p>Additionally, if an issue in one of the panels required modifications to the next batch, it would be too late as they would have been in shipment.</p>	<p>Urban One Builders</p>
<p>Installation</p>	<p>Hook chains to the CLT panels using specified information from Structurlam in four locations</p>		<p>One interesting strategy used was to lift the panels at an angle to ensure ease of installation when lowering into place. This made the installation faster by allowing the installers to first pull the two rods at one of the ends before moving to the opposite side.</p>	<p>Urban One Builders</p>
<p>Installation</p>	<p>Lower into place and align using a laser pointer</p>		<p>An idea was brought up to "piggy-back" the CLT panels. It means rigging a small CLT panel on top of a large CLT panel. Then installing the large CLT panel into position and hooking the small panel and install it. This saves the following two crane trips:</p> <ol style="list-style-type: none"> 1. Empty return trip from deck to ground, after installing the large CLT panel 2. Rig trip from ground to deck hauling the small CLT panel 	<p>Azadeh Fallahi</p>
<p>Installation</p>	<p>Release the attached chains</p>		<p>Columns are lined and plumbed after the upper CLT has been installed. This process takes one third to half a day and requires two laborers</p>	<p>Urban One Builders</p>
<p>Installation</p>	<p>Tighten bolts and secure into place</p>			

Installation	Safety railing installed on the perimeters		The use of a special guard rail system made securing the edges of the floors fast and efficient. These guard rails could be drilled in a matter of hours and dismantled and used later.	Azadeh Fallahi
Installation	Nail and bolt splines into place at the perimeter of the panels	-	The splines were initially going to be installed with just screws, but it was decided that fixing it in place with screws, and nailing the rest was more efficient and just as structurally sound.	
Installation	Install the steel Dragstraps at specified locations		The drag straps were screwed to the CLT slabs, and bolted to an angle back at the core. The angles were welded to the core.	Azadeh Fallahi

Alternative Installation Method	<p>This method was proposed by the site superintendent inspired by formwork fly tables, but was not implemented by the timber erector trades for this project:</p> <ol style="list-style-type: none"> 1. Stand the columns and place their pin. Then brace columns at gridlines c and d 3. Install the first CLT panel (#19) and adjust the location of CLT #19 panel using the twist buckle in column bracing and a laser level pointer 5. Fix CLT panel to the concrete wall using SDS (strong-drive screws) 6. Install the second CLT panel (#20) and adjust it in place using the same way and install spline between CLT panels to fix them and continue installing the first strip the same way by using the first strip of CLT panels as a reference for the remaining panels 	<p>According to the structural superintendent, the advantages would have been the elimination of spaces and cutting down on amount of labour required, (currently 2-3 people in each of ground, lower floor and upper floor.</p>
---------------------------------	--	--

5.3 GLT and PSL Columns

Construction and Product Description

The installation of the mass timber columns began on June 9th, 2016 and finished in early august (Aug 9th), 2016. That puts the entire duration at about two months.

The columns used in the construction of Brock Commons are made of mass timber, specifically from GLT and PSL (Parallel-Strand Lumber) elements. The majority of the columns were GLT and only in the 2nd -5th floors PSL were used on the interiors of the building to mitigate some of

the settlement that occurs on the timber. Particularly since this building is a hybrid timber and concrete building, the difference in settlements between timber and concrete was an issue to be resolved in the design stages. It was determined by the structural engineers that 24mm of settlement was to occur and the decision was made to use a stiffer material for some of the elements that have the most compression hence the use of PSL columns. Since all the columns are to be covered with gypsum, the appearance grade of all the columns is industrial.

There are 78 columns per floor and all the GLT columns are made of Douglas Fir, with stress grades elaborated in Table 5-3. The connections are Hollow steel structure (HSS) tubes in which the top of the columns have the slightly larger tube to allow for easy assembly of the columns by just sliding the column connections inside each other.

The Table 5-3 summarises the size, weights and the material of all the columns as well as the floors each of which are used in:

Table 5-3 Column types: Extracted from the supplier shop drawings





Column type	height	Width	Length	weight	Material	Stress Grade	Levels used
1	265	265	2332	260	GLT	16c-E	2
2	265	265	2332	303	PSL	2.2E	2
3	265	265	2532	316	GLT	16c-E	3-9
4	265	265	2532	363	PSL	2.2E	3-5
5	265	215	2532	262	GLT	16c-E	10-17
6	265	215	3517	279	GLT	16c-E	18



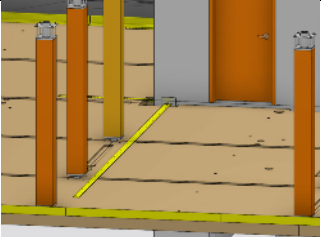
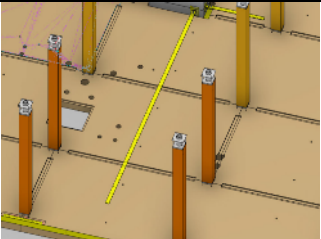

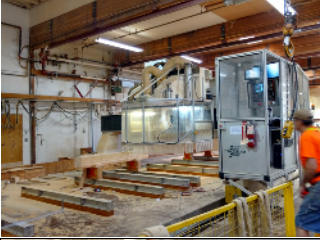
Process Description

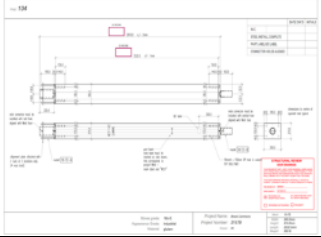

There are two stages to cover in the process description of the columns. The first is the activities during the pre-fabrication of the columns. Table 5-4 illustrates each step involved in the process along with pictures and comments. The comments in blue denote lessons learned, the ones in green show a point of interest and the purple demonstrates any challenges or constraints the team faced:

Table 5-4 Column process flow

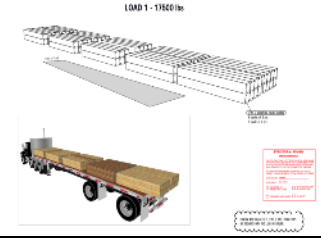
Phase	Activities	Photos	Comments	Image Credit
Pre-fabrication	The columns and the thicknesses and heights were designed by the structural engineers and peer reviewed to ensure structural adequacy.	-	During the design development, the specs of the columns were discussed. The supplier was then given the chance to either prove their existing products is compliant with what is required or work on producing and expanding on their existing catalogue. This was since locally sourcing the timber would decrease shipping costs and help grow BC economy which were one of the main drivers for the ROI (CWC request Of Interest)	
Pre-fabrication	They were then modeled in Catia by the VDC integrators (CadMakers). Catia is part of 3d experience, a multi-platform software suit for design and manufacturing developed by the French company, Dassault Systemes.		The Catia software isn't widely adopted by the AEC industry, and therefore file sharing must happen through more universal exports of the model.	CadMakers Inc.
Pre-fabrication	A .stp export of the model was sent to the supplier. A. Stp is a simple geometry file with no built-in information about the elements of the model. Information such as fire rating, r values or material properties.		-	CadMakers Inc.

Pre-fabrication	The supplier took the .stp model and made modifications to their available catalogue of products to ensure the specific design requirements match that of the final product. The .stp was imported into the software used by the timber supplier, Cadwork wood.		The geometry file (.stp file) was then modified in the software to adjust for items such as saw thickness and drill bit diameters to ensure the tight tolerances are achievable	Azadeh Fallahi
Pre-fabrication	The columns were cut based on the specified dimensions using CNC machines that operate by importing the 3d model into		The CNC machines cut the columns automatically based on the model fed to them.	Azadeh Fallahi
Pre-fabrication	The holes were drilled into the two ends of the column to be ready for steel connection installation			Azadeh Fallahi
Pre-fabrication	The steel connections were brought to the supplier to be installed to the timber columns		The timber supplier believes it is better practice to have all the columns be required to be a couple mm shorter, and use shimming plates to rise to the exact level height required to eliminate possible issues arising from the columns being too tall. This would additionally eliminate the need for QC on every single one of the columns to be performed in the future.	Azadeh Fallahi
Pre-fabrication	The steel connections were installed to the columns		Initially the idea was to have the timber portion of the column be to 1mm and have the steel plates to be 1mm so that the overall tolerance be 2mm. During the mock-up stage, when the steel pieces and the timber pieces arrived on site separately, it was determined that including the connections in the scope of the timber supplier is more reasonable as they could check all these values before arrival on-site and resolve any potential issues earlier due to better control over QC.	Azadeh Fallahi

Pre-fabrication	QC was done for every single column individually using the QC sheets		The supplier was working to $\pm 2\text{mm}$ tolerances (as opposed to their usual $\pm 6\text{mm}$). This is a much higher level of QC than the supplier generally does, and adds time and cost to the process for them.	Supplier Shop Drawings
Pre-fabrication	The columns were wrapped in plastic (in bundles) and were prepared for shipment		-	Azadeh Fallahi
Pre-fabrication	The columns were loaded on the trucks based on the loading schedule.		the loading schedule was developed ahead of time with all the trades present to ensure the installation sequence is repetitive and predictable every time.	Supplier Shop Drawings
Installation	The benchmark elevation was shot to determine whether the heights do or don't require shimming	-	-	-
Installation	10 bundles of columns were lifted and placed at their respective locations on the rooftop floor. These bundles were daisy chained to increase efficiency by lifting two bunches at a time		This was decided later, to save time. According to the site superintendent the timber erectors were not used to working in heights and with cranes, therefore there was a learning curve in the beginning to get familiar with efficient crane operation.	Azadeh Fallahi
Installation	The columns were then placed next to their respective connection. The yellow marks the locations.	-	-	-
Installation	The perimeter columns were lifted using a special rig and with men wearing fall protection		The timber erectors are generally used to working in shorter heights. Therefore, performing their assembly process using a crane required they develop a new workflow which took some time in the beginning but ended up outperforming the rest of the operations in terms of assembly durations. The erectors developed a specialty rig to help lift the columns at the perimeters as the standard practice is to lift the columns in bunches using a crane and then lift manually into place.	Azadeh Fallahi

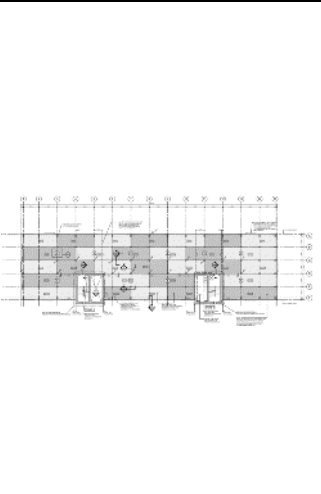
Installation	Inside columns were lifted and fixed into place manually by the workers		The use of PSL columns in the interiors of the building for levels 2-5 was to accommodate excessive forces at the lower floors which required a higher stress grade that PSL provides. Issues with that were that PSL is more expensive and heavier than GLT	Azadeh Fallahi
Installation	The HSS (hollow steel structure). Connections were placed inside each other and they were fixed with a pin. They were then checked for height to see if they require any shimming.	-	Even though the columns were all within +/-2 mm tolerances, extra shimming plates (steel) were provided from the supplier to ensure they can adjust the heights of the columns if it is required.	
Installation	The diagonal supports and braces were placed to keep the columns from tilting and rotating in place before the arrival of the CLT panels above.		-	Azadeh Fallahi
Installation	One issue has been to mitigate slack at the bottom of the columns in the east-west direction, where the bolt hole and slit are. To address that, spacers (generally a short piece of dimensional lumber) are added to the far north and south columns in each north-south row, and a reference line is run between the columns. Then the columns are pushed in the right location so that the distance between the reference line and column face are equal to the spacers' width.		Most interior walls run north-south. Thus, any error in aligning column bottoms would increase the wall widths, reducing the floor area of units; hence, reducing the profit earned by developer. A lesson learned is to have bolt holes in column-column connections running the same direction as most interior walls.	IFC Structural Drawing

5.4 Building Envelope

Construction and Product Description

There are multiple construction timelines for the fabrication of the building envelope. The design was finalized in April 2016, with testing completed in May 2016. The pre-fabrication of the envelope panels began in early June 2016 and the installation were performed from June 21, 2016 till September 9, 2016.

The envelope panels are steel studs with punched windows. The prefabricated portion is composed of the exterior rain screen cladding system up to the steel studs. The vapor barrier, batt insulation and the interior layer of drywall were applied on site. The panel system is supported on a 127 x 127 x 13 steel angle that is installed to provide additional stiffness around the building's entire perimeter at each level.

There is a wood wraparound that are used to keep the steel studs flush. There are very detailed precautions taken to ensure there are minimal to no leakages at the connections and edges that include multiple flashings and seals. Figure 5-5 and Figure 5-6 illustrate the steel stud system, the wood wrap around and the flashing detail that contribute to the structural rigidity and leakage proofing of the panels.

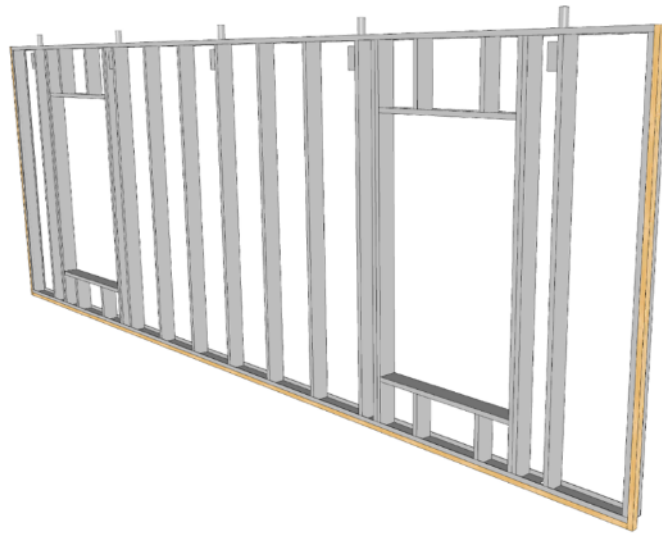

Figure 5-5 Wood wraparound on the steel stud structure for added flushness (Courtesy of RDH)

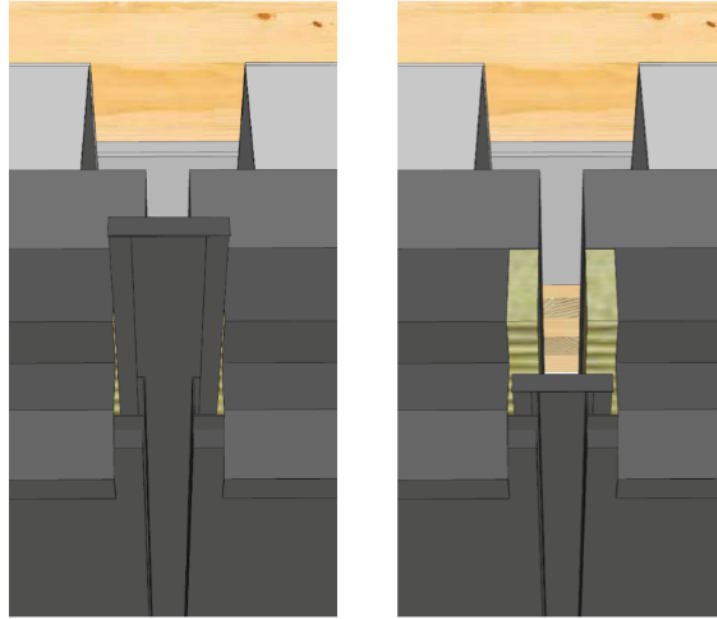

Figure 5-6 Flashing detail (Courtesy of RDH)

The connection between the lower panels and ones from the floor above are through a male-female connection shown in Figure 5-7. The male part was cut at an angle to make insertion easier for the installers on site. There are two general types of panels, flat panels and the corner “L” panels as illustrated in Figure 5-8. There were rigs bolted and welded to the ground for each different panel type and size at the fabrication plant, and different crews would rotate around the plant to install the various layers of the envelope panels as pictured in Figure 5-9 and Figure 5-10.

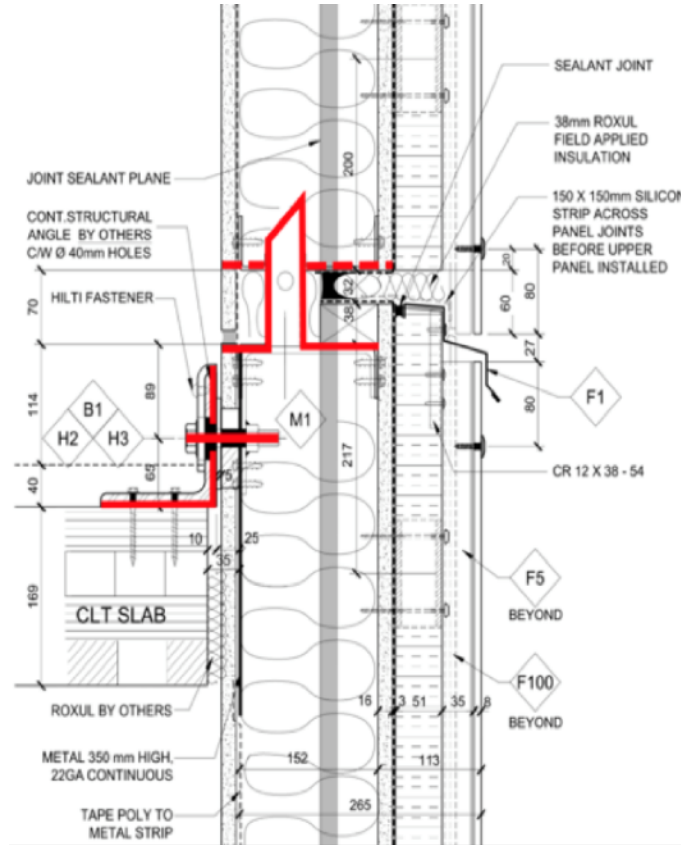

Figure 5-7 Envelope cross section showing the connection details and the envelope section (Courtesy of AOA)

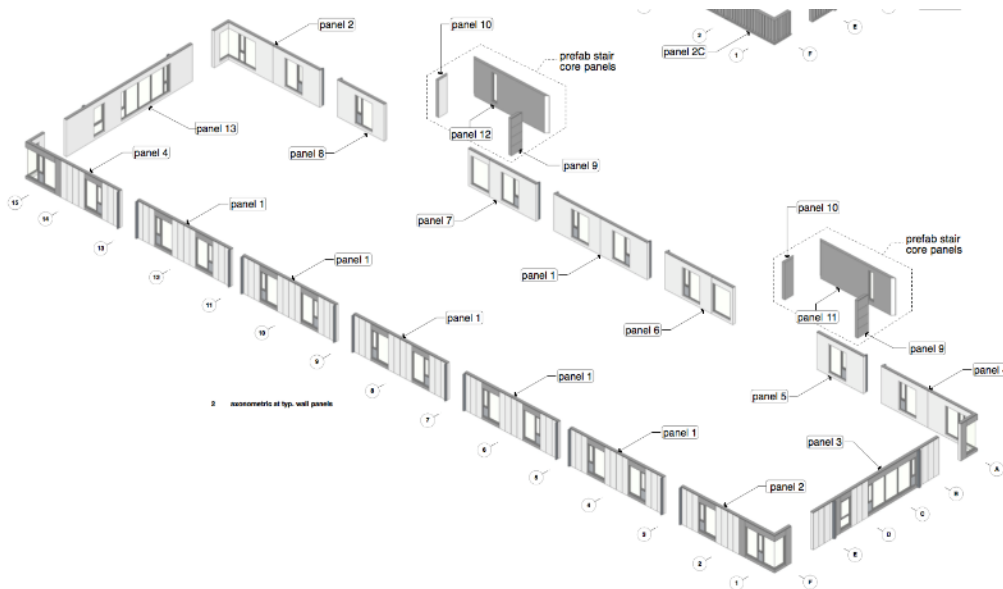

Figure 5-8 Panel types for the building enclosure (Courtesy of UrbanOne Builders)



Figure 5-9 Envelope plant, jigs fixed onto the floor, for each different panel type



Figure 5-10 Building envelope plant

The panels were tested on a mock-up structure ahead of attaining the final approvals to ensure no water will come through and that the installation sequencing and connections are exactly as planned (Figure 5-11).









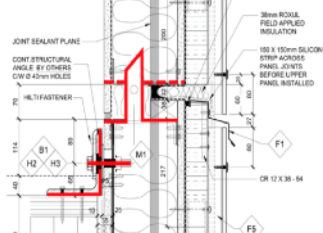

Figure 5-11 Mockup testing (Courtesy of RDH)





Process Description

There are two process stages for the envelope panels; Pre-fabrication and installation. The table below illustrates each step involved in the process along with pictures and comments. The comments in blue denote lessons learned, the ones in green show a point of interest and the purple demonstrates any challenges or constraints the team faced:

Table 5-5 Envelope panel process flow

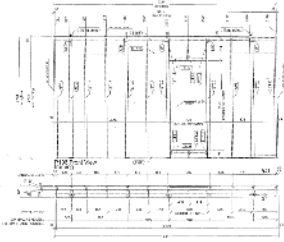
Phase	Activities	Photos	Comments	Image Credit
Prefabrication	Special rigs with exact dimensions of each panel type welded to the ground at the plant		<p>The main lesson learned for the project team was through planning and developing a functional system, the tight mandated tolerances were achieved. It is important to disclose that the energy and acoustic performance of the panels were not analyzed in this thesis as it was outside the defined research scope.</p>	Azadeh Fallahi
Prefabrication	Steel studs installation		-	Azadeh Fallahi
Prefabrication	Drywall and weather proofing installation		-	Azadeh Fallahi
Prefabrication	Insulation layer installation		-	Azadeh Fallahi
Prefabrication	Trespa panel installation to the outside		-	Azadeh Fallahi

<p>Prefabrication</p>	<p>Windows installation</p>		<p>Since the wind has been an issue when lifting the panels, an idea has been discussed to install the windows on site after the panels were fixed in place (to have holes in them and be less privy to wind sways). However, this idea couldn't be implement for this project as the windows are installed on the exterior of the panels with the current design.</p>	<p>Azadeh Fallahi</p>
<p>Prefabrication</p>	<p>Connection details</p>		<p>The I angles on the perimeter were installed protruding from the building to allow for better accuracy of the edges, in case the CLT panels weren't exactly lining up on the edges.</p>	
<p>Prefabrication</p>	<p>The I panel transportation</p>		<p>One challenge that arose during construction was that the approval process for the corner "I" panels took longer than anticipated. The approvals were supposed to be issued from the building envelope consultant but since some design aspects changed in over the course of the project, the process took longer. This delay meant that for some time, the I panels could not be produced (to avoid rework). Another challenge was that the production and transportation of the "I" panels were more difficult than the flat panels as they don't stack up, but due to aesthetic reasons, the building designers wanted them to be done.</p>	<p>Azadeh Fallahi</p>
<p>Prefabrication</p>	<p>Stacking in trailers and shipping</p>		<p>In turn, this resulted in the fabricator having to work harder later when the approvals were issued, to make up for the I panels and keep the same rate of production for the flat ones. Initially they produced more flat panels (16 panels/3days in the beginning, going up to 26 panels/3days to make up for I panels that were delayed. Every cycle, two additional I panels produced to make up for the schedule.). By the 14th floor, the panels were caught up to the original schedule</p>	<p>Moh Kasbar</p>

Installation	Hooking of the panel for lifting at points specified in the shop drawings		The envelope panels were very sensitive to wind while being lifted (crane required to be stopped at 35km/hr. Wind vs. The 50km/hr. Wind for the clot panels). A suggestion has been to either lift them horizontally and use a special rig to tilt them up upon arrival to the installation location.	Supplier Shop Drawings
Installation	Fitting base connection to lower panel's header connection (same as lifting point)		In level 2 (first level of envelope cladding) connectors installed in concrete curb	Moh Kasbar
Installation	Half-fastening to top level's corresponding holes in the perimeter angles		The miter cuts at the corners do not allow the timber erectors to install them close-fitted. As a result, holes in corner l-angles do not line up with holes in envelope panels. A bevel cut would allow a more close-fitted installation.	Moh Kasbar
Installation	Checking elevations using laser a level		The holes in the l-angles were wider than the holes in the envelope panels. The bolt used corresponded to the envelope panel hole and thus checked to ensure in the 100% square location. In order to do so, gums, shims and micro-shims were used.	Moh Kasbar
Installation	Using shims at the bottom to adjust elevation per instructions from upper slab worker			
Installation	Final checking of elevation		One interesting fact about the panels is that even though they were specifically designed for this project, they can now be used in any type of construction that requires rapid and accurate closures.	From RDH Presentation
Installation	Fully fastening and fixing the envelope panels in place			
Installation	Unhooking lifting chains and releasing the crane			

5.5 Specialty Construction Considerations

As timber was the main structural material for this building, on top of general site and construction safety measures, much more rigorous and comprehensive considerations were given to protect the building against fire and water damage as both are detrimental to wood. The strategies are described in the next two sections. The water and fire safety and management during construction were focused on the protection of the timber elements, and therefore were in

effect from June to September 2016, when the timber elements were being installed and before they were fully concealed with gypsum boards and concrete. The next two sections describe each of those strategies in more detail:

5.5.1 Water Management during Construction

The following fire risks and mitigation strategies were identified by the project team during design:

1. erection of mass timber structure scheduled for Spring/Summer seasons
2. water resistant coatings on wood elements to minimize water absorption during construction.
This didn't change when they had to revise the plans.
3. prefabricated temporary rain protection potentially erected during wet weather conditions
4. prefabricated building envelope installed approximately one level behind erection of structure. This didn't change in the revised strategy also.
5. man-hoist connection to building to allow for control of rain shedding
6. water flow alarm used at main water entry room after hours; main water shut off at night
7. fire standpipes not charged during construction; standpipe valve caps wrench tightened.
8. site security presence to commence at start of wood structure erection; personnel to receive training regarding water damage prevention and mitigation
9. concrete topping covering wood slab structure may be sloped to direct drainage
10. building envelope consultant involved in moisture content assessment of wood structure prior to encapsulation

The water management plan was updated once the first rainfall on site proved that the CLT panels are much more permeable than initially anticipated. The decision was made to have more levels have their concrete poured to protect the CLT panels during rain fall events. In the original

strategy, the water management was done using peel and stick products, the CLT sealant and water diversion pipes as illustrated in Figure 5-12 and Figure 5-13. The revised strategy later relied on the acoustic concrete topping to act as a barrier for water to pass through.

The original strategy was:

- Using peel and stick membrane to cover the holes and openings. Some, as shown in Figure 5-12 were done in the plant, and the edges and connection points of the CLT panels were to be taped and sealed on site;
- Using more peel and stick when the CLT panels are installed at the perimeters of the panels and at the perimeters of the building;
- Using the sealer on the CLT panels to keep water from permeating into the panels both at the plant and again when splines are done installing on site;
- Having rainwater collection holes and diversions to guide water down.

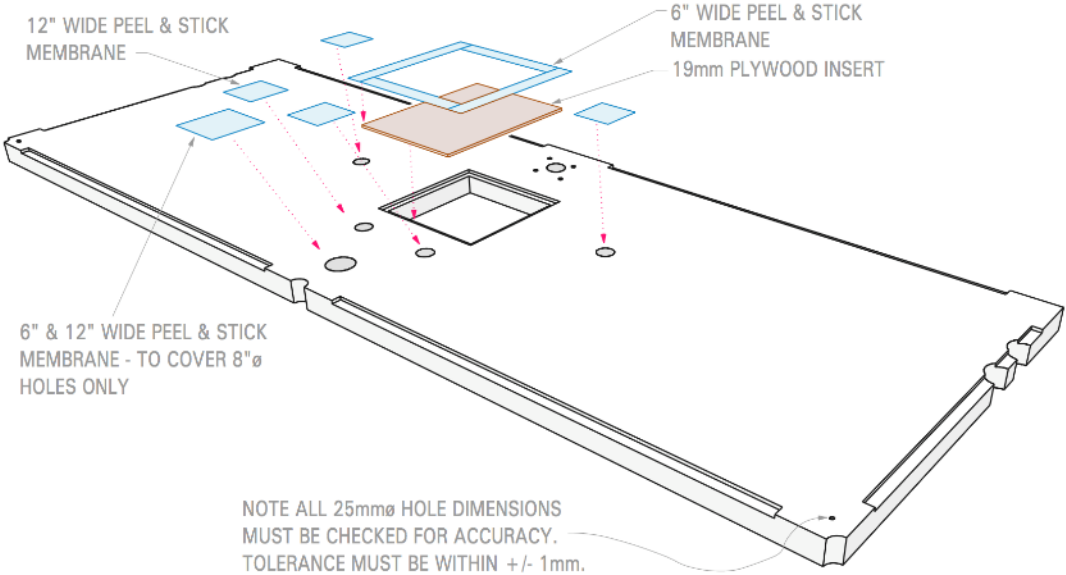

Figure 5-12 Original water management strategy at fabrication plant (Courtesy of UrbanOne Builders)

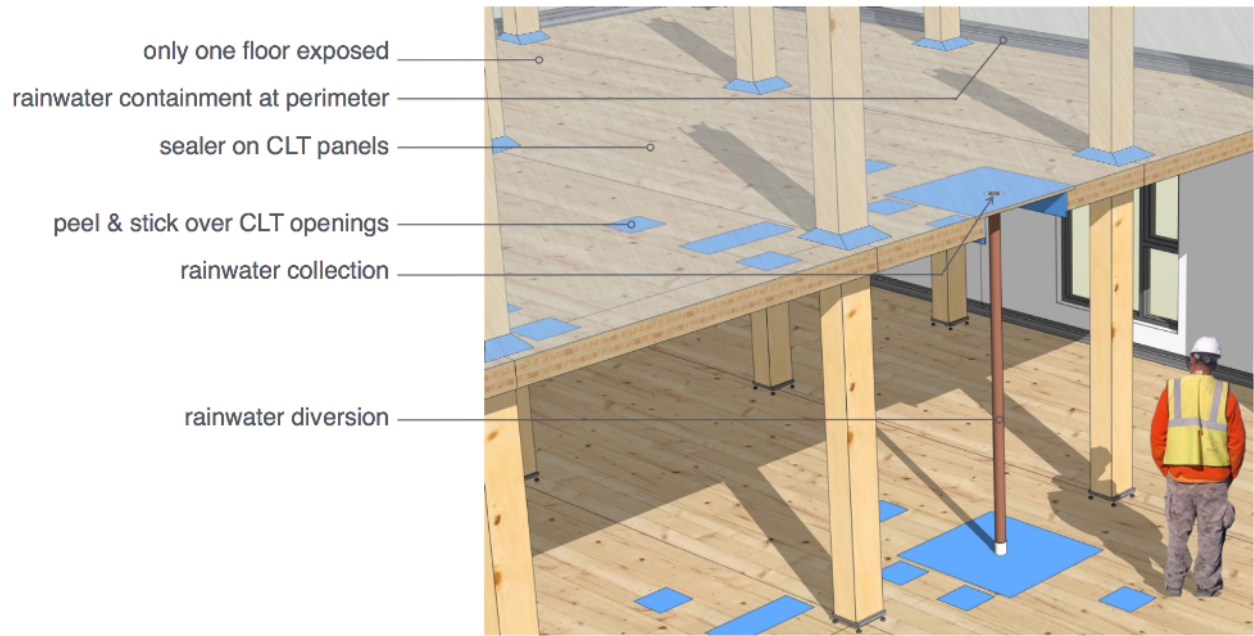

Figure 5-13 Original water management strategy (Courtesy of AOA)

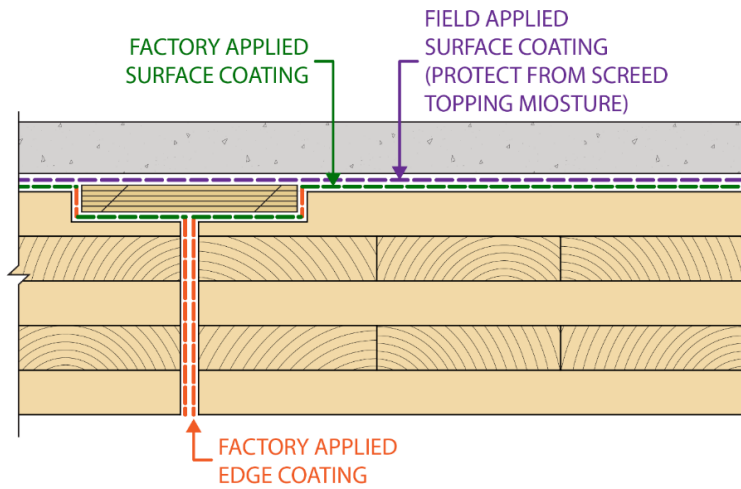

Figure 5-14-Moisture protection at different stages of the CLT panel (Courtesy of RDH)

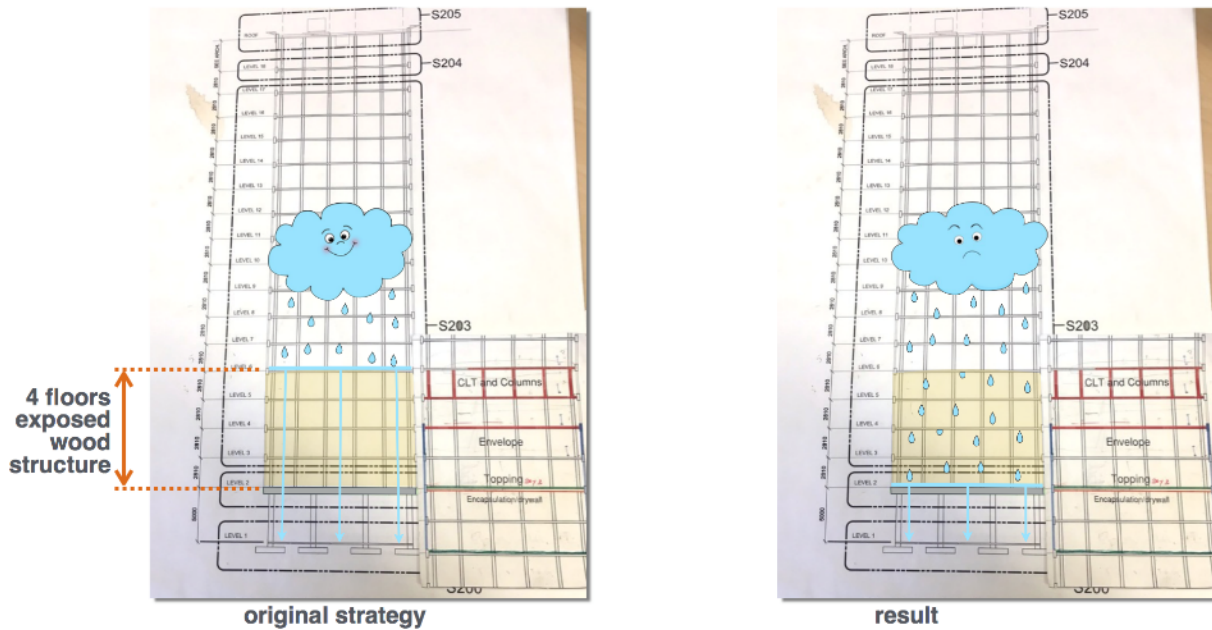

Figure 5-15 Original rainwater strategy (Courtesy of AOA)

The revised strategy became:

- Having six levels of exposed CLT panels (with no Type X Gypsum);
- Fully tanking the floors with concrete topping and prevent permeating water into CLT panels;
- Allowing more floors to have concrete topping and not lag due to gypsum;
- Installing the envelope panels to keep water out of the building.

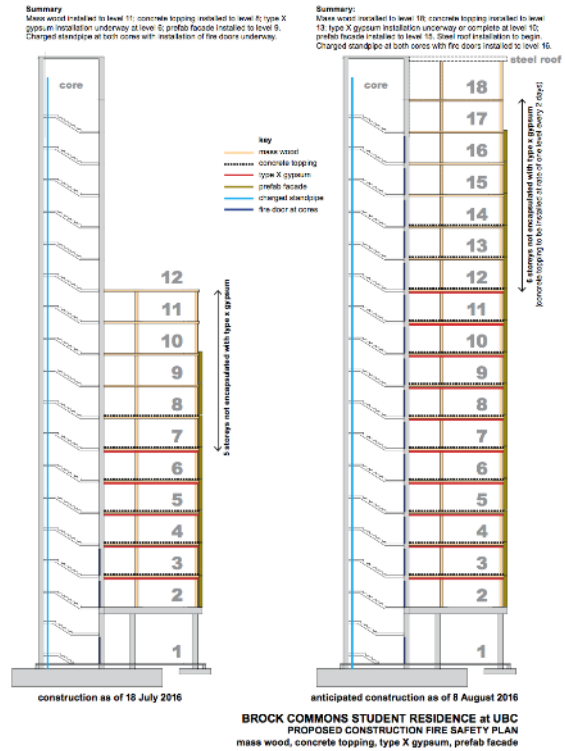
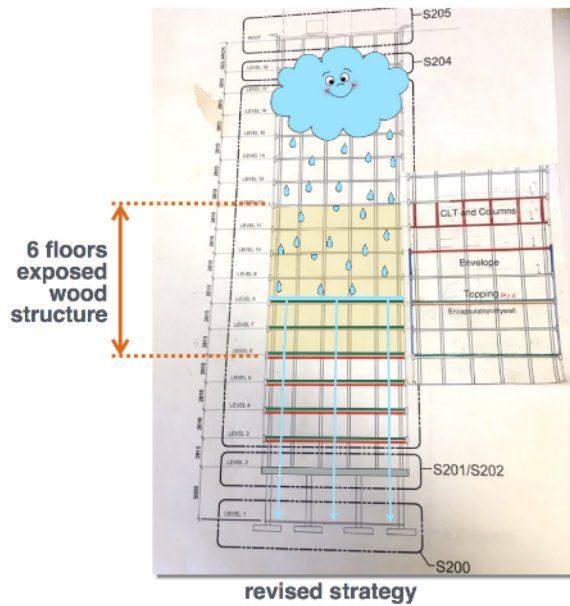

Figure 5-16 Revised rainwater strategy - Adding the number of exposed floors to be able to pour concrete and tank floors (Courtesy of AOA)

Discussion

The first and main challenge has been the realization that the CLT panels are more permeable than the team anticipated. This means in case of any rainfall; water will immediately travel through the panels and will fully soak the floors below.

Another challenge has been the sheer amount of rainfall the site experienced despite the timber elements having been scheduled to be installed in the driest months of the year. Vancouver has experienced the most rain fall in recent years on the summer of 2016.

Finally, changing the water management plan did have implications on the fire safety plan and before proceeding with the modified plan, the VFRS (Vancouver Fire and Rescue Services) had

to approve the plan and ensure fire safety isn't compromised with the overall schedule duration staying unchanged.

One of the comments the PM received frequently was why tarp was not used to mitigate rainwater penetrating the CLT slabs. According to her, use of tarp is a safety hazard, and is also cluttering the work surface, therefore other water management systems were used. Even though the CLT panels were very permeable and would get wet very fast, they also drain fast and as long as there a barrier from rain was provided, they would dry back to acceptable moisture contents very fast in a matter of days. That said, excessive wetting and drying can change the mechanical and chemical properties of the panels, therefore the team put in every effort to prevent the panels from getting wet to begin with.

It was learned that the CLT panels will dry back to acceptable moisture contents in two days even if they get wet. So, while it is preferred that they stay dry, the team now knows how to deal with accidental spills and water exposure to panels.

It is the opinion of the construction site team that their experience working in the excessive rainy weather and their modified water management plan will enable them to build similar projects all year around.

5.5.2 Fire Safety and Management during Construction

The following fire risks and mitigation strategies were identified by the project team during design:

1. detail wood structure to minimize or eliminate welding; hot work permit process in effect for hot work activities by trade contractors; fire watch personnel posted as required
2. temporary heat to be used will avoid open flame heat within the structure

3. fire standpipes to be constructed no less than four levels below active structure deck and to be available for use by Fire Department; temporary Siamese connection installed
4. CLT slab structure to be encapsulated with 1 layer Type X gypsum board with no more than four levels of unprotected wood structure exposed at any one time
5. site security begins at wood structure erection; training in fire prevention and fire response
6. Fire Safety Plan to be reviewed and approved by Vancouver Fire Department

The strategy changed throughout the implementation of the fire management plan since excessive rainfall forced the team to change the water management plan which in turn affected the fire management plan. The original strategy relied heavily on the type X gypsum board to be installed on the ceilings to ensure the CLT panels are fire proof. However, with the approval from VFRS (Vancouver Fire and Rescue Services), the strategy was revised to allow for the acoustic concrete topping to act as the fire stopping.

All the information below is taken directly from the construction site safety plan that focuses on special considerations due to the main building element being timber. The strategies are divided into three categories, for protection during construction activities, for protection of adjacent buildings and for protection of project (Urban One Builders, 2016):

1. Construction activity protection

- Excellent housekeeping will be maintained to prevent build-up of flammable materials and to maintain safe access and egress through the project. The fire load within the building will practically nil to prevent ignition of any material;
- No more than six storeys of mass timber will be unprotected with Type X Gypsum Board. Of the six storeys, 1-2 of the storeys will have a 40mm concrete topping installed as per Figure 5-17;

- Both core access doors on Level #1 are locked each night, so access to top levels is not possible;
- All electrical feeds for temporary power are routed through the concrete cores and not through the CLT;
- Smoking will not be permitted within the boundaries of the worksite;
- Use of a hot work permit system is in place. Any of the following are categorized as hot work and a special form signed by the superintendent or safety officer needs to be obtained prior to work commencement:
 - Cutting
 - Welding
 - Soldering
 - Brazing
 - Grinding
 - Open flame heater;
- A chargeable stand pipe will be installed on each floor concurrently as the building is being erected;
- A chargeable fire department water connection will be installed at street level as soon as reasonably possible during the construction of the project;
- Flammable/combustible liquids shall not be stored in the building. Only a quantity required for the day's activities will be allowed in the building;
- All flammable/combustible liquids shall only be stored in the lockable and fire rated storage container that is located away from the building. This will prevent the entry of unauthorized personnel or inadvertent contact from vehicles or mobile equipment;

- Flammable/Combustible liquids shall be separated from other dangerous goods;
- ‘No Smoking’ signage will be prominently posted in any areas directly involved in the storage, handling and use of flammable liquids and combustible liquids. (There is no smoking permitted anywhere on site)

2. *Strategy for protection of adjacent buildings:*

- Fire separations between any building undergoing construction will have the internal fire separations installed as soon as practical during the construction of the buildings to minimize fire spread throughout the structures;
- Fire rated doors into the exit stairs will be installed as soon as practical and will be latch able;
- the sprinkler system will be installed as soon as reasonably practical;
- Storage of combustible materials will be kept to a minimum and will be located away from neighbouring properties where possible;
- Quantities of combustible materials will be kept to a minimum on site.

3. *Strategy for protection of Project:*

- No more than six levels of CLT slabs are to be exposed and unprotected from potential fire at a given time;
- The CLT panels are to have moisture content no greater than 19% when one layer of fire-rated drywall is attached directly to its underside. The Building Envelope Consultant will be involved in evaluating the wood moisture content of the CLT panels;
- A concrete topping will be placed atop the CLT; however, the sole purpose for the concrete topping is for acoustical considerations, not for protection of the CLT panels from potential fire;

- Night security guard is on site every evening (6:00PM – 07:00AM) and 24 hours on weekends. This project is not relying on CCTV; however, there are several web/time-lapse cameras taking different views of the site 24/7.

Summary

Mass wood installed to level 11; concrete topping installed to level 8; type X gypsum installation underway at level 6; prefab facade installed to level 9. Charged standpipe at both cores with installation of fire doors underway.

Summary:

Mass wood installed to level 18; concrete topping installed to level 13; type X gypsum installation underway or complete at level 10; prefab facade installed to level 15. Steel roof installation to begin. Charged standpipe at both cores with fire doors installed to level 16.

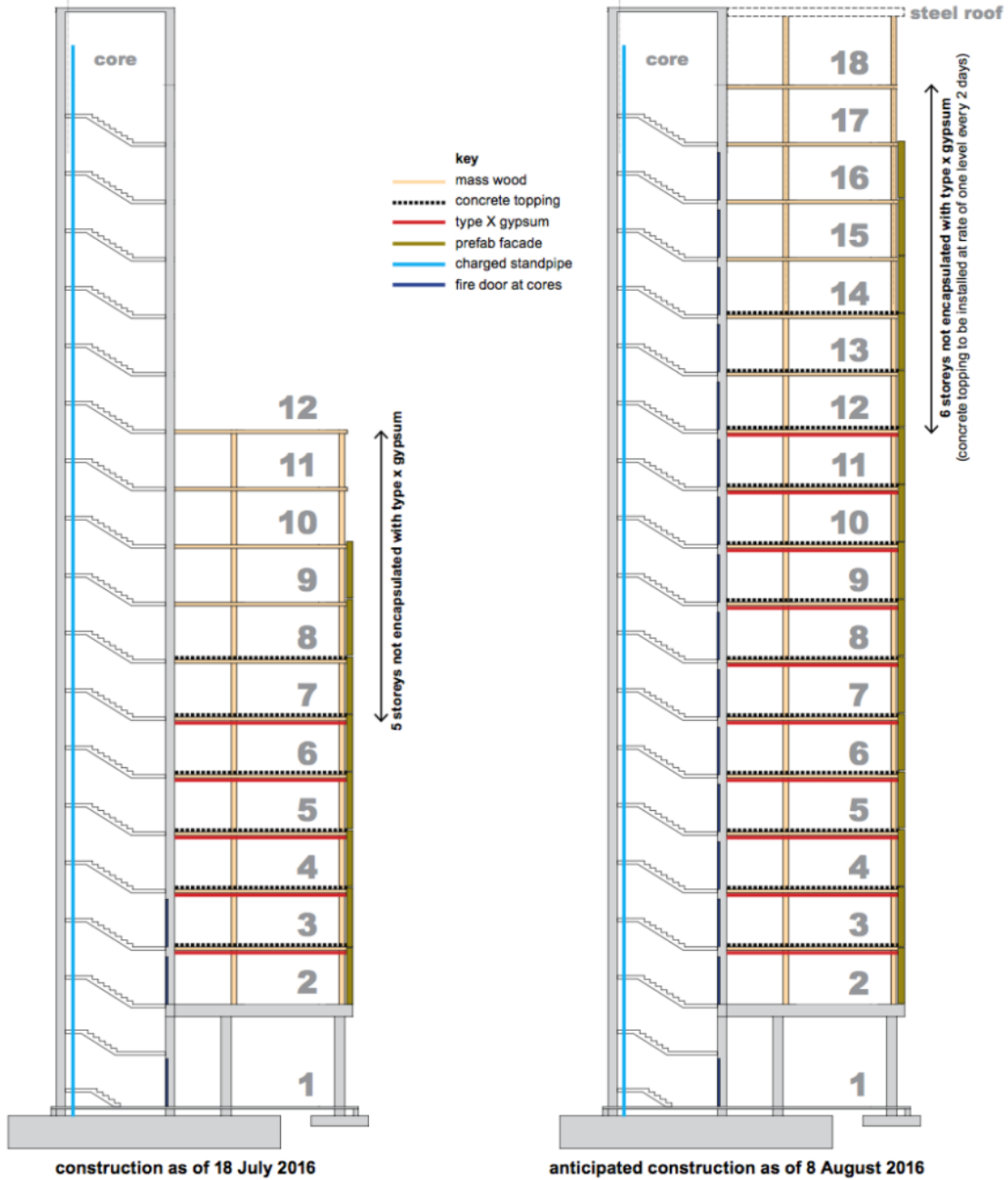

**BROCK COMMONS STUDENT RESIDENCE at UBC
PROPOSED CONSTRUCTION FIRE SAFETY PLAN
mass wood, concrete topping, type X gypsum, prefab facade**

Figure 5-17 Revised rainwater strategy approved by Vancouver Fire and Rescue Services - Adding the number of exposed floors to be able to pour concrete and tank floors (Courtesy of AOA)

Discussion

The main challenge with this fire safety plan has been getting approvals from the VFRS (Vancouver Fire and Rescue Services) when the plan was modified to include more levels of exposed CLT on the ceilings. This meant the team had to formally devise a modified protection plan and present to the VFRS and they came and did a site visit to approve the new plan.

The GLT columns do not require encapsulation by drywall according to the construction fire safety plan. That is due to the fact that the columns are separated from the CLT panels with the acoustic concrete topping and even though it doesn't serve fire protection, it provides separation from the floor.

Another point of interest is the fact that since all the construction and performance stages of the building are comparable to that of a concrete building, typical measures necessary when building a wooden stick frame building are not necessary here. One such measure is the use of the fire screens.

Some of the lessons learned in this part of the construction include the reinforcement of the idea that fire protection and weather management plans go hand in hand even more than usual for this building, both because of the nature of timber which is vulnerable to both fire and water damage.

Another learned lesson is the demonstration that even through there was a need for changes to the weather management plan, the fire can also be modified in a way to allow for the schedule to stay unchanged.

Chapter 6: Innovative Uses of Virtual Design and Construction

As the use of the timber mandated the project be done faster and with more precision to justify using a novel construction material and still make economic sense for UBC, the design and construction process for Brock Commons needed to follow the innovation in the form of extensive use of VDC. Defining the role of the VDC integrators through the different phases of the design and construction process as well as tracking how the model was being evolved is captured in this chapter through the methodology elaborated in chapter 4. The bulk of the communication between the VDC integrators and the team was through formal and informal means, including both the detailed handover of design and construction documents, as well as phone calls and emails clarifying certain information or potential clashes. In this section, the software of choice is discussed, along with a description of the different project stages they were involved in and their inputs and outputs.

6.1 VDC Integrator Software

The company utilizes the cloud based “3D EXPERIENCE” platform developed by Dassault Systemes that claims to be one of the most powerful 3D modeling software and project management tool in the market. According to the platform website, the platform aims to streamline modern construction through real-time process and cost visualization, efficient construction using prefabricated components, just-in-time delivery of materials and information, cash flow improvement, and efficient collaboration among all stakeholders (Dassault Systemes, n.d.).

The Dassault suite includes a number of “app” like software that are available to the users, based on their permissions and assigned roles. As a viewer, the designers, construction managers and the owner were all given access to the latest model, which can be opened,

panned, rotated and zoomed based on element names (Dassault Systemes, n.d.).

However, during the different stages, there were frequent meetings with the active project members of that stage to advance the model and plan the subsequent steps. Generally, the meetings would consist of the CadMakers modeler, the construction or project manager, the designers and available trades. The model would be displayed on a screen and responsible parties' comments would be built into the model as further 3d details, solutions to clashes or animations and sequencing videos to inform the construction process.

The apps within the 3D EXPERIENCE that was most widely used for this project are illustrated in Figure 6-1:

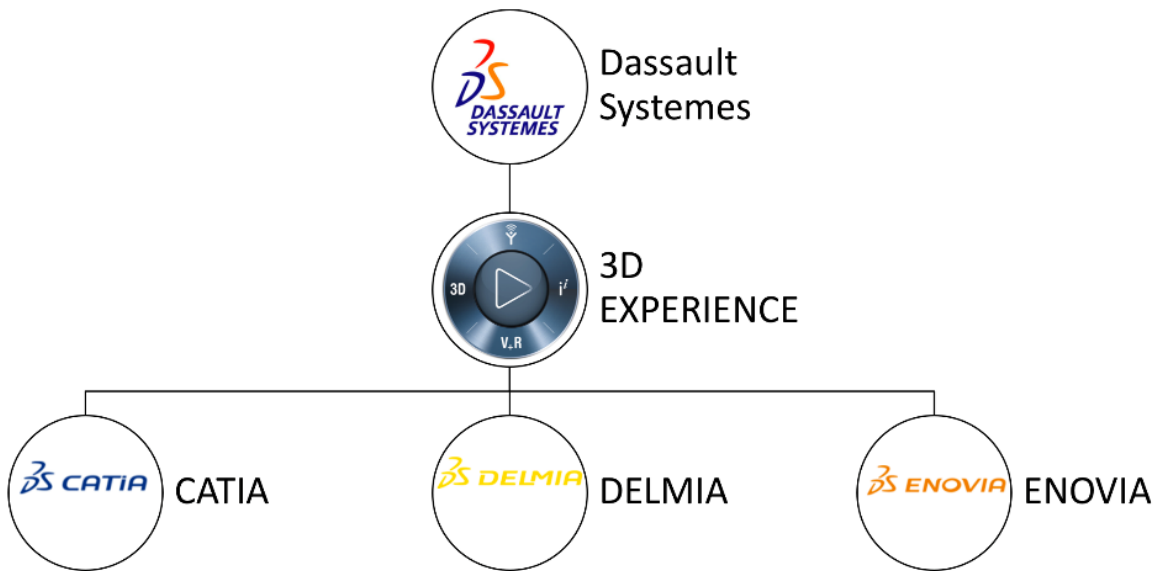

Figure 6-1 3D EXPERIENCE suite by Dassault Systemes

1. **CATIA:** This is the 3D modelling app within the suite and provides the ability to model a product in the context of its real-life behavior. The software is commonly used in the aerospace industry; however, Dassault has been working on making the product more

suitable for the AEC industry. In its current form, it is “A Social design environment built on a single source of truth” which means at any given time, the all contributors look at and work on the same model to ensure the latest changes are reflected (Dassault Systemes, n.d.).

2. **DELMIA:** This app is used for managing the products from a “manufacturing” lens and gives the opportunity to design and test in a simulated production environment. It can create powerful animations and create 4D to test and measure the installation times on site before even breaking ground on the construction site.
3. **ENOVIA:** This app is the one that allows the different collaborators (with or without editing rights) to navigate through the latest model (single source of truth) and quickly pull out BOMs, make comments and ask for clarifications and manage the contents of the VDC model at any given time.

6.2 VDC Model Evolution and Use Workflow

The VDC integrator had been involved from the very preliminary design phase, before the project was officially approved by the UBC board of Directors. In order for the project to be viable for UBC, the design and construction team met and coordinated to ensure the building (minus the available funding of Table 3-1) would not cost any more than a typical concrete building since any difference would have to be made up from student tuitions.

The VDC integrators were at the table during the initial design workshop, working collaboratively with the structural engineers, the architects, the construction manager and the owner to parametrically model the proposed designs in CATIA, do quantity take offs, and create cost and budget estimations. The same take offs were also used to calculate the costs of the same

design made from concrete (typical construction material for UBC) in order to compare costs and ensure the building is economically viable.

The VDC integrators were present through the remaining project phases, namely the design development phase, the construction phase and also during the mock-up phase.

6.3 Preliminary Design Phase

During the preliminary design phase, the architects presented the basic design of the building. The design was a variation of the Ponderosa Phase II project for the layout, as UBC has found the floor layout to be the optimal design, and a simple façade to accommodate the opportunity of pre-fabrication. The structural engineers worked through a variation of different configurations, and narrowed down the structural design to three choices out of which one without beams was selected. The decision to eliminate beams was to keep the uninterrupted floor heights to a maximum, in order to allow for hung MEP, as contrary to a concrete building, in-slab configuration was not an option. Two of the last options are shown in Figure 6-2.

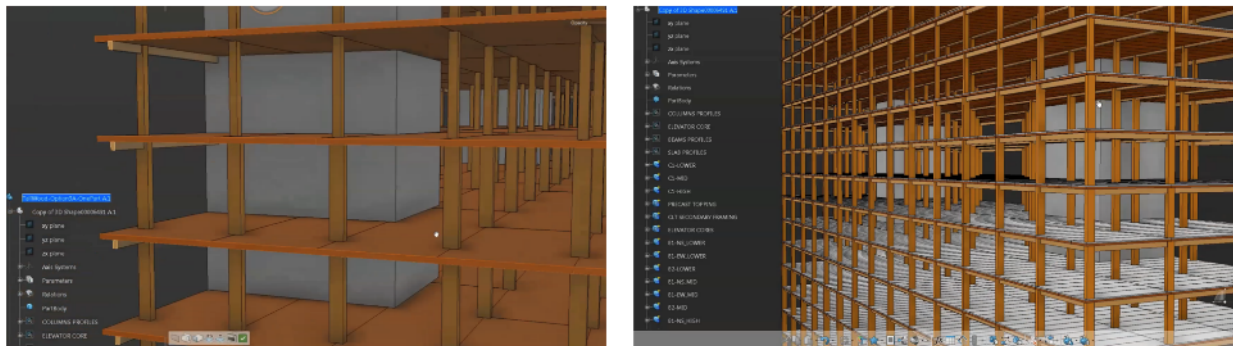

Figure 6-2 Left: Structural option 1a. (beam Option), Right: Structural option 3a. (2-way slab Option)
(Courtesy of CadMakers)

The basic architectural design, and the three structural options were brought to a 3-day collaborative design workshop and the building was modeled in 3D. From there, quantity take-

offs were done, and using expert judgement and technical knowledge, the construction cost was estimated to ensure the building cost could to be contained to that of a concrete proxy.

Images Courtesy of CadMakers and Urban One

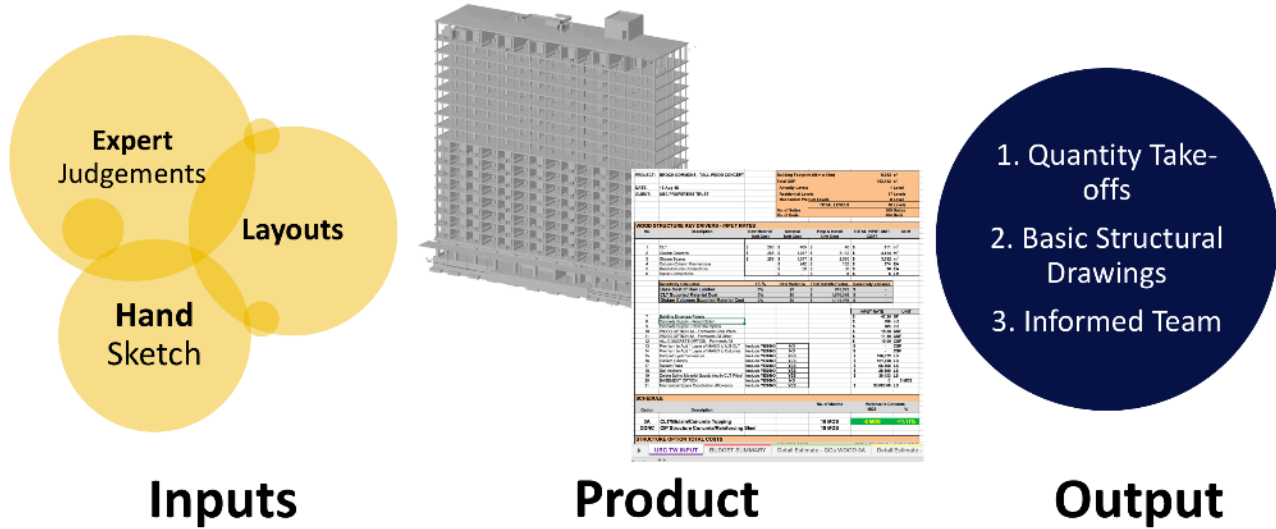

Figure 6-3 Inputs, products and outputs of the VDC model during preliminary design phase

6.3.1 VDC Preliminary Design Stage Inputs:

In this stage, the inputs included the hand sketches from the structural engineers (as shown in Figure 6-4), basic architectural layouts and floor plans developed by Acton Ostry Architects and the knowledge of the people present in the room during the design workshops (as shown in Figure 6-5).

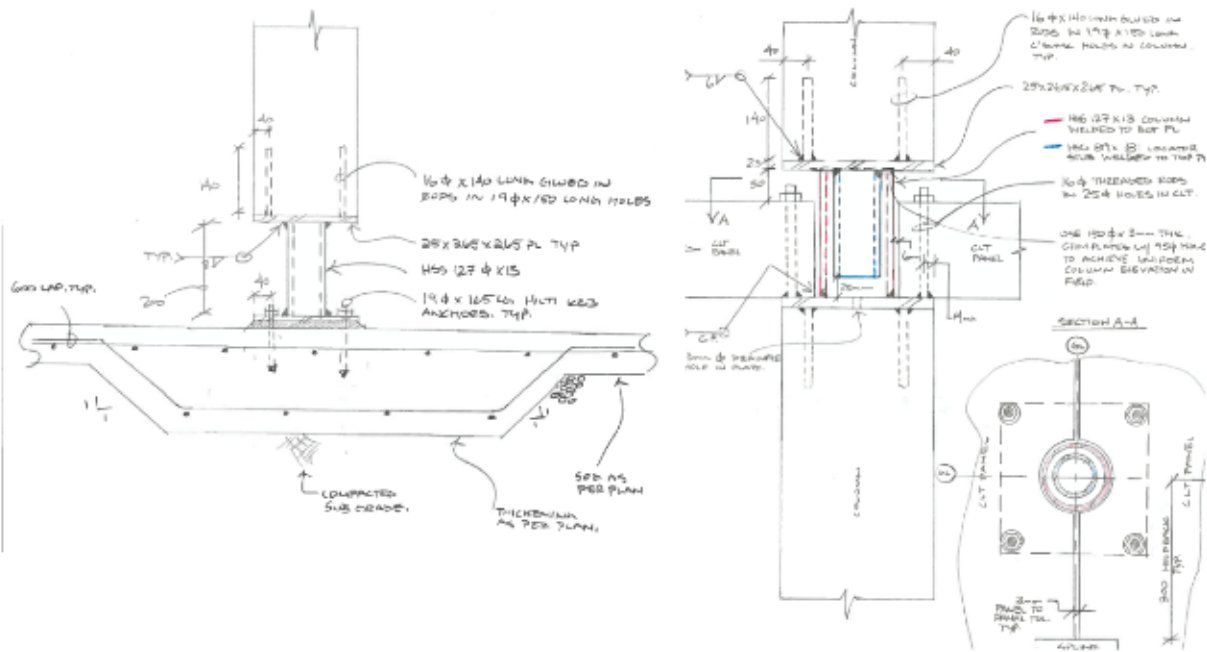

Figure 6-4 Preliminary structural design hand sketches (Courtesy of Fast and Epp)



Figure 6-5 3-day design workshop (Courtesy of Acton Ostry Architects)

6.3.2 VDC Preliminary Design Stage Products:

At this stage, the products produced by the VDC integrator were preliminary models showing the chosen design, along with volumetric and numeric information about the building elements as pictured below in Figure 6-6.

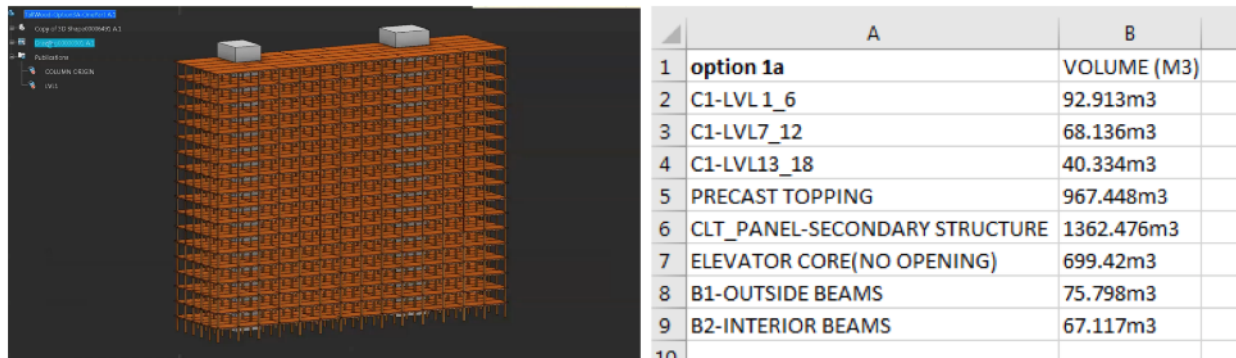

Figure 6-6 VDC products during the preliminary design stage

6.3.3 VDC Preliminary Design Stage Outputs:

After the VDC models were created and basic quantity take offs were done, the outputs were detailed excel spreadsheets developed by the construction managers, that used quantity take-offs from the VDC integrator, unit prices for labour and material from the trades and their own knowledge and cost breakdowns from the Ponderosa Phase II project which has served as a precedent for Brock Commons. The numbers were adjusted to include inflation and market predictions for the time of construction and a verbal agreement was reached that if all the trades could commit to the number they had given, the job would be theirs. Additionally, shop-drawing-like 2d documentation was produced, to assist the bidders in project understanding, to minimize uncertainty for bidders that could inflate costs for the bid proposal. Figure 6-7 shows both the spreadsheets developed during the design workshops and the bidder's packages created by CadMakers:

PROJECT:	BROCK COMMONS - TALL WOOD CONCEPT	Building Footprint (56m x 15m)	9,042 of
DATE:	19-Aug-15	Total GSF	162,752 sf
CLIENT:	UBC PROPERTIES TRUST	Amenity Levels	1 Level
		Residential Levels	17 Levels
		Mechanical Plenum Levels	2 Level
		TOTAL LEVELS	18 Levels
		No. of Suites	305 Suites
		No. of Beds	404 Beds

WOOD STRUCTURE KEY DRIVERS - INPUT RATES						
No.	Description	Raw Material Unit Cost	Material Unit Cost	Prep & Install Unit Cost	TOTAL INPUT UNIT COST	UOM
1	CLT	\$ 265	\$ 485	\$ 46	\$ 811	m ³
2	Glulam Columns	\$ 265	\$ 1,017	\$ 3,132	\$ 4,414	m ³
3	Glulam Beams	\$ 265	\$ 1,017	\$ 2,050	\$ 3,332	m ³
4	Column-Column Connections	\$	\$ 242	\$ 132	\$ 374	EA
5	Beam-Column Connections	\$	\$ 90	\$ 30	\$ 96	EA
6	Spline Connections	\$	\$	\$ 6	\$ 6	LM

Sensitivity Calculator				
+/- %	Rate Variance	Total Installed Value	Sensitivity Variance	
Base Cost of Raw Lumber	0%	\$0	\$ 15,072	\$ -
CLT Supplied Material Cost	0%	\$0	\$ 1,870,016	\$ -
Glulam Columns Supplied Material Cost	0%	\$0	\$ 1,114,976	\$ -

		INPUT RATE	UNIT
7	Building Envelope Panels	\$	47.20 SF
8	Concrete Supply - Wood Option	\$	190 m ³
9	Concrete Supply - Concrete Option	\$	185 m ³
10	WOOD OPTION 3A - Formwork Core Walls	\$	15.00 CSF
11	WOOD OPTION 3A - Formwork All Other	\$	11.50 CSF
12	ALL CONCRETE OPTION - Formwork All	\$	10.00 CSF
13	Premium to Add 1 Layer of MAGD to URB CLT	Include YES/NO	NO
14	Premium to Add 1 Layer of MAGD to Columns	Include YES/NO	NO
15	Parapet Eyebrow Feature	Include YES/NO	YES
16	Podium Canopy	Include YES/NO	YES
17	Raised Plaza	Include YES/NO	YES
18	Seal Anchors	Include YES/NO	YES
19	Delete Spline Material Supply (Inc in CLT Price)	Include YES/NO	YES
20	BASEMENT OPTION	Include YES/NO	NO
21	Mechanical Space Coordination Allowance	Include YES/NO	YES

SCHEDULE			
Option	Description	No. of Months	Variance to Concrete MOS %
3A	CLT/Glulam/Concrete Topping	16 MOS	-2 MOS -11.11%
CONC	CIP Structure Concrete/Reinforcing Steel	18 MOS	

STRUCTURE OPTION TOTAL COSTS	
UBC TW INPUT	BUDGET SUMMARY

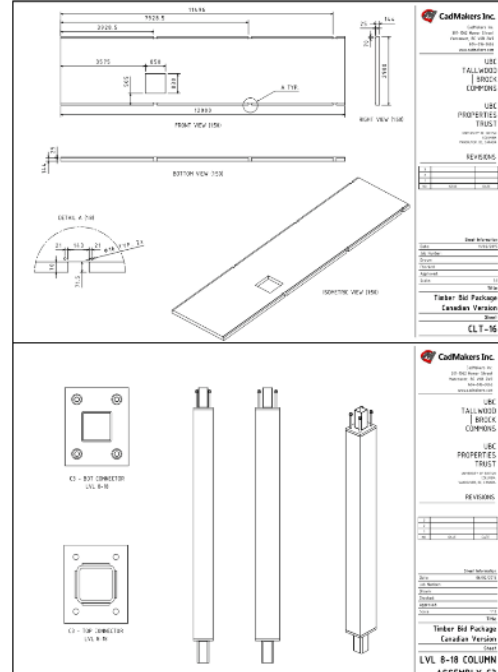

Figure 6-7 Left: Cost estimations done by the construction manager during the design workshop (Courtesy of UrbanOne Builders), Right: Bidders package supplementary information (Courtesy of CadMakers Inc.)

6.4 Design Development Phase

After the project approval and go-ahead was obtained, the preliminary design was further expanded upon, and the designers commenced working on detailing and finalizing the plans. In this stage, the official project deliverables for the team were the same as other UBC projects, which are 2D drawings. However, the VDC model was being further developed and updated on a parallel track, and as the designers were working on the drawings, the VDC integrator was incorporating them into the master model as well. This allowed the VDC integrators to identify any potential clashes or inter-disciplinary coordination issues early on, and ask for clarifications or changes before the issue caused further problems downstream.

Images Courtesy of CadMakers

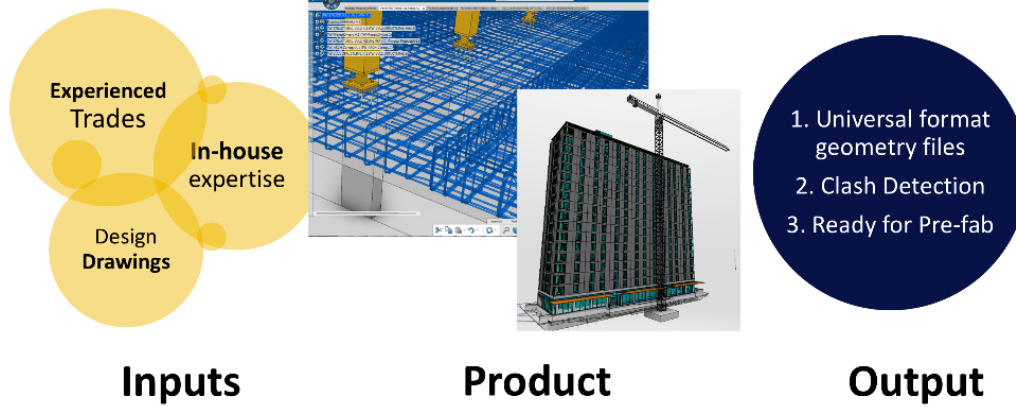

Figure 6-8 Inputs, products and outputs of the VDC model during design development phase

6.4.1 VDC Design Development Stage Inputs:

The main VDC model inputs in this phase were the design drawings being developed as shown in both Figure 6-9 and in Figure 6-10.

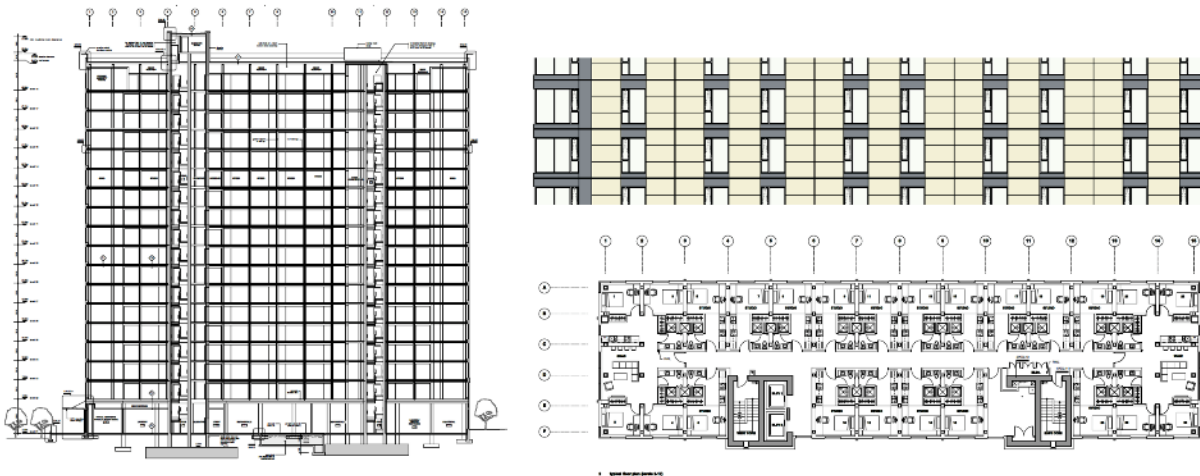

Figure 6-9 Architectural design development drawings used as input for the VDC model

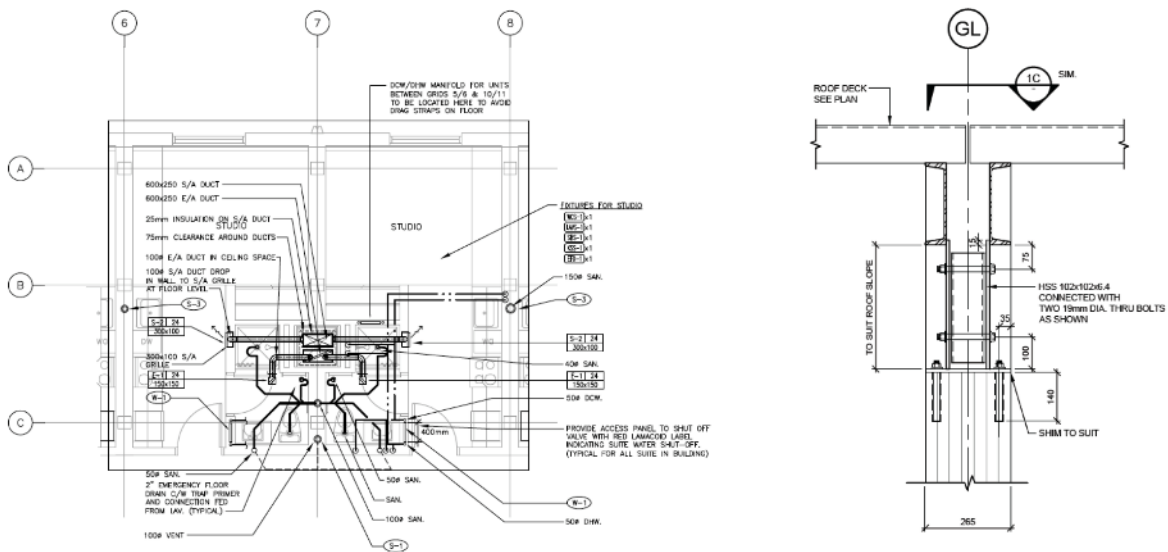

Figure 6-10 Right: Mechanical design development drawings used for VDC, Left: Structural design development drawings used for VDC

Additionally, due to the VDC integrator being directly hired by the owner, and the owner mandating clear and continuous communications between the VDC integrator and the team, the model was constantly being updated through both formal written questions (similar to an RFI, but for the VDC integrator) pictured in Figure 6-11, and through informal phone and email communications.

Subject	Discipline
W1 DCW/DHW riser clashing with S/A duct from AHU-1	Mechanical <input checked="" type="checkbox"/> - <input checked="" type="checkbox"/>
Drawing Reference: P2.01, and M2.01	Drawing Status: IFT <input checked="" type="checkbox"/>
Question/Issue: LVL 1 @ Grid C'-5' DCW and DHW riser clashing with S/A duct from AHU-1. M2.01 shows duct at 1200x450 and DCW DHW riser - 1200mm from CMU wall - when accounting for flanges and insulation (~50mm all around) this appears not to fit.	
Suggestion: Narrow duct to 1050mm wide to allow for riser to fit since Riser cannot be move east without being outside of the wall above	
Answer: 2015-11-03: • mechanical to advise - probably offset pipe to the east <div style="text-align: right; color: red;"> CM Update 2015-11-09: If Riser is offset, it will be outside of the wall in the washroom above, please confirm </div>	

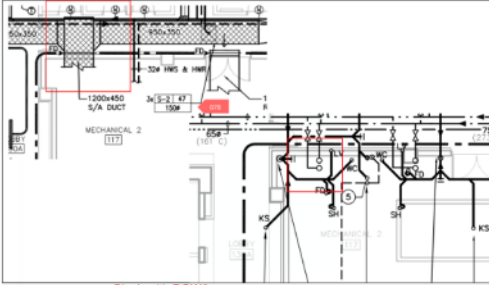
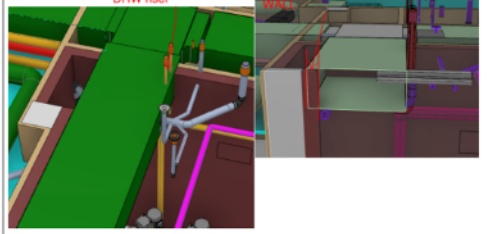



Figure 6-11 VDC integrator official communication with the design team

Finally, the VDC integrator brought in experienced trade to sit with in their offices to help do a detailed layout of the MEP configurations, as it is standard in the construction industry for the MEP designers to include a general layout in the drawings highlighting the important engineering considerations, and it is the responsibility of the trade to determine the final detailed layout on site. By having the trades brought on earlier, the VDC integrator was able to identify any potential constructability issues ahead before the design phase concluded to make adjustments to the general layout. The reason the team insisted on knowing the exact locations and configurations for the MEP was to coordinate the openings in the CLT slabs to allow for pre-fabrication of the mechanical room. Two examples of constructability issues identified in the design development phase are illustrated in Figure 6-12 and Figure 6-13.

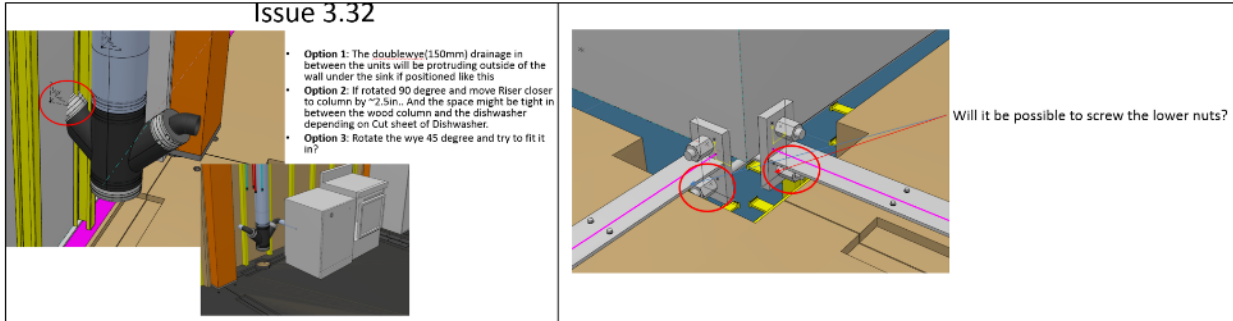

Figure 6-12 Constructability issues identified in the design development phase by the VDC integrator

(Courtesy of CadMakers Inc.)

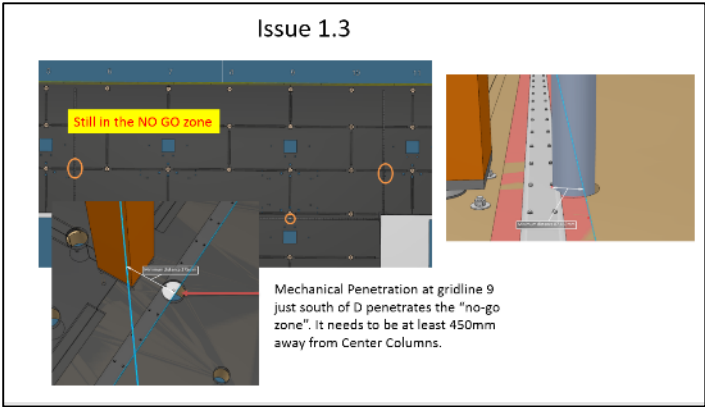

Figure 6-13 Constructability issues identified in the design development phase by the VDC Integrator

(Courtesy of CadMakers Inc.)

6.4.2 VDC Design Development Stage Products:

The VDC product at this stage was a detailed 3D coordinated model, with the exact locations of all the MEP, CLT openings, rebars and reinforcements, interior finishings and envelope panels determined as shown in Figure 6-14 and Figure 6-15 below:

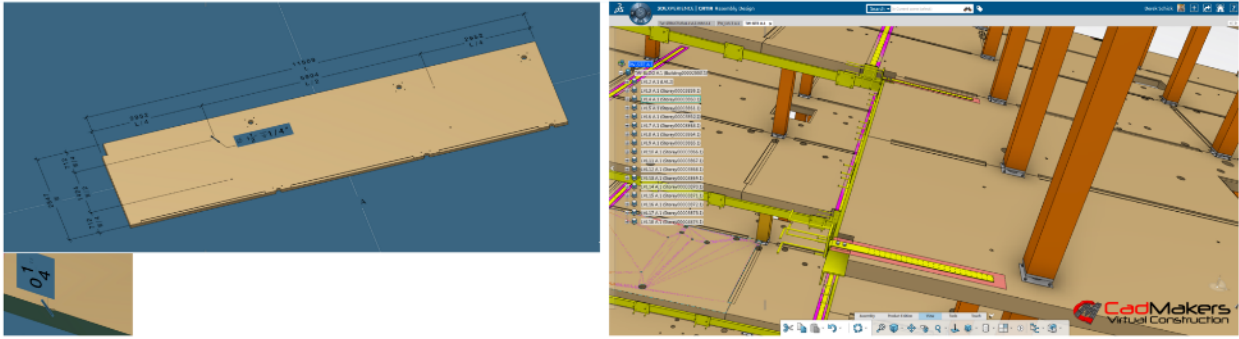

Figure 6-14 CLT panel dimensions from the coordinated model in the design development phase by the VDC integrator (Courtesy Of CadMakers Inc.)

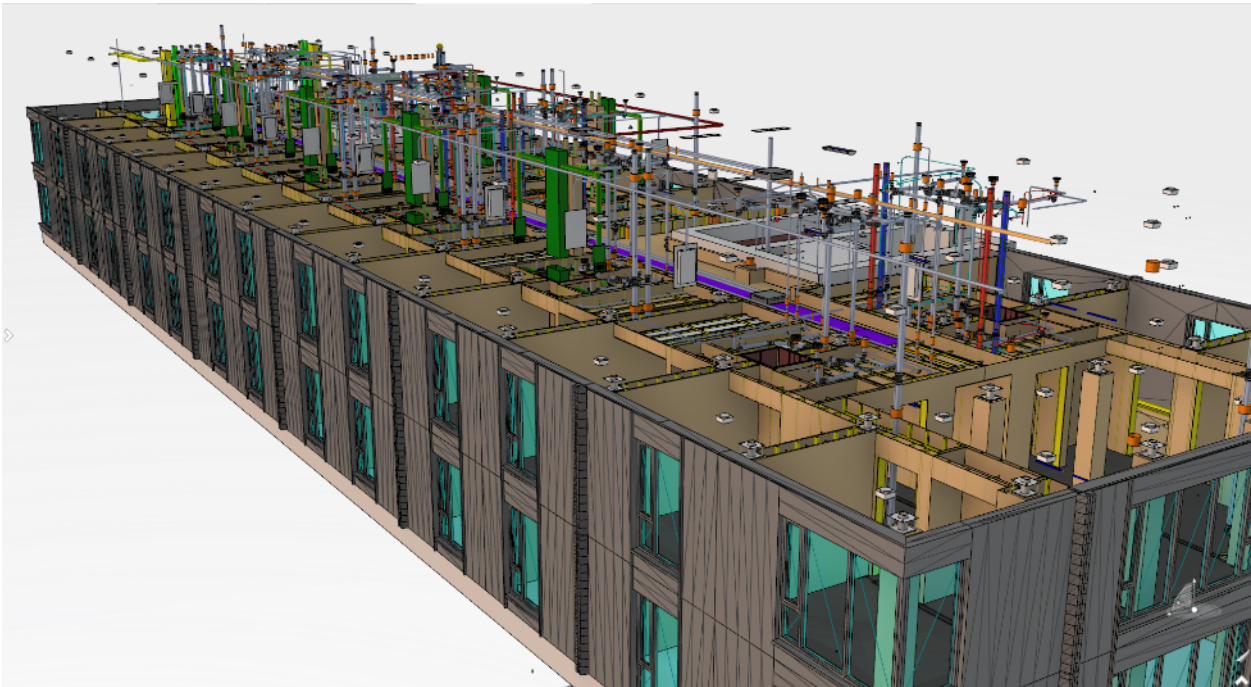

Figure 6-15 Design development VDC model (Courtesy of CadMakers Inc.)

The coordinated MEP elements for the Mechanical room and the floors were optimized by the VDC integrators to be pre-fabricated. These helped shave time off the construction schedule and allowed for extensive pre-fabrication due to the repetitive nature of the spool packages across the floors.

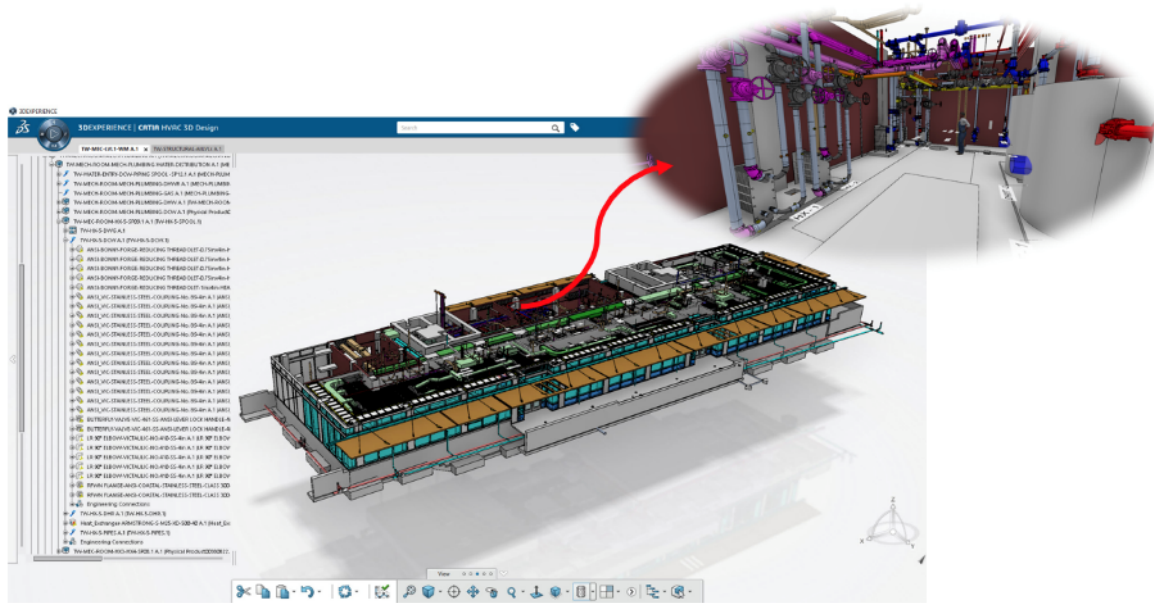

Figure 6-16 Mechanical room coordination by VDC integrators during design development phase

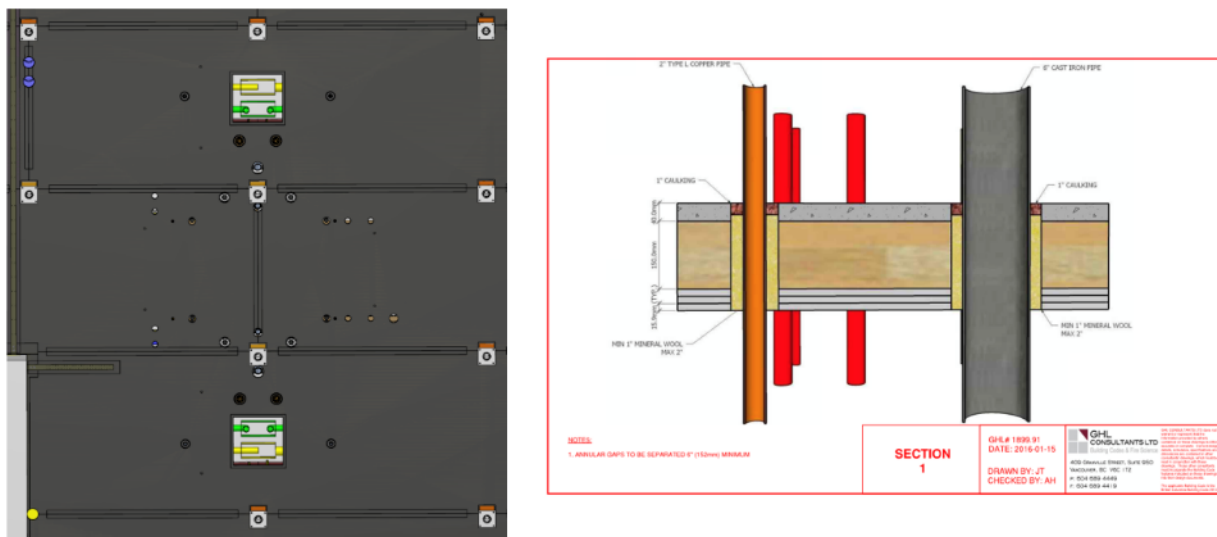

Figure 6-17 Fire-stopping locations and details incorporated into the VDC model

6.4.3 VDC Design Development Stage Outputs:

Upon fully coordinating the building elements, universal file formats such as .stp and .ifc versions of the model was exported and sent to the corresponding suppliers, along with the project documents (2d drawings) to be manufactured offsite. Additionally, for the MEP

elements, a bill of material and detailed description of the spool packages and their dimensions were sent to the MEP trade as illustrated below in Figure 6-18:

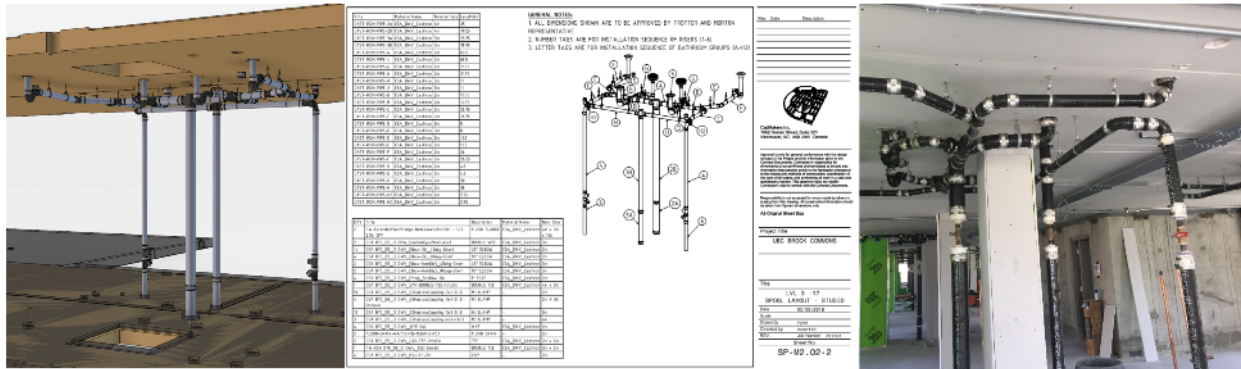

Figure 6-18 MEP modeled in VDC, turned to BOM and installed on site (Courtesy of CadMakers Inc.)

The VDC of the mechanical room was also turned to bill of materials to allow for pre-fab as illustrated below in Figure 6-19:

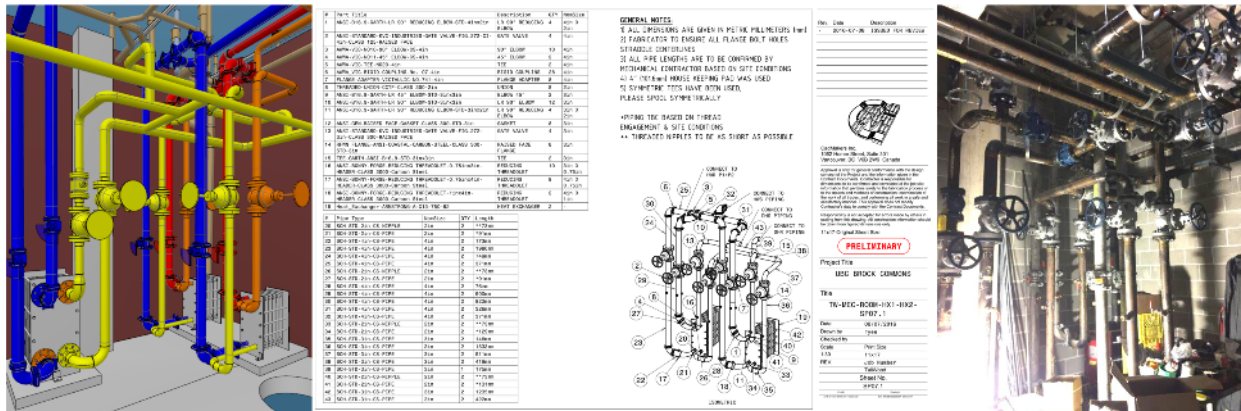

Figure 6-19 Mechanical Room VDC, turned to BOM and installed onsite (Courtesy of CadMakers Inc. and UrbanOne Builders)

Finally, the locations of the penetrations and canning were coordinated in the VDC model to prevent any potential clashes onsite, as illustrated below in Figure 6-20:

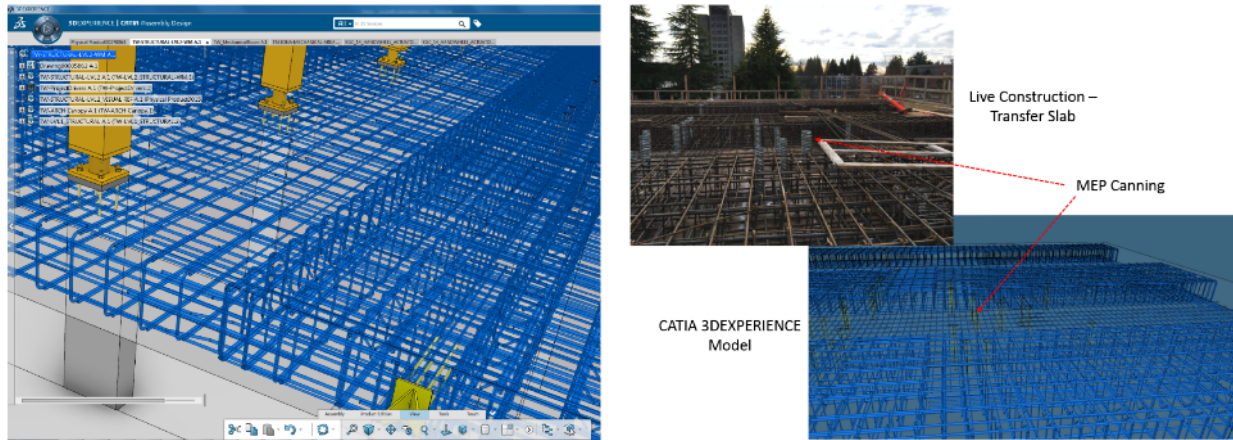

Figure 6-20 Rebar and MEP canning location coordination in VDC

6.5 Mock-up and Project Construction Phase

A point of interest unique to this project was the construction of mock-up before the main construction. The purpose of this exercise was to practice the construction methods, and test the sequencing and connections on site. The resultant model incorporated the construction scheduling and sequencing, and helped the project team develop construction strategy documents including safety plans, transportation and loading schedules and installation sequencing. These documentations were used to inform the team, analyze and increase efficiency in the installation methods and ensure rapid and streamlined movement of material onsite (due to limited storage space on site). The main advantage of wood for this project is the speed of erection. This and the fact that timber is not meant to be exposed to weather for long periods, meant that these construction method analyses were crucial to project success.

Images Courtesy of CadMakers and Urban One



Figure 6-21 Inputs, products and outputs of the VDC model during construction and mock-up phase

6.5.1 VDC Construction and Mock-up Stage Inputs:

During the construction of both the mock-up and the building, the VDC integrators were engaged with the construction team and trades, through trade meetings on-site (Figure 6-22), communication with the project manager, using their in-house expertise and consulting with experienced trades in their offices. Other inputs for the VDC integrators at this stage included Sis (Site Instructions), all the submittals, project schedules, contractor bids and chosen products.



Figure 6-22 VDC Integrator and construction team and trade meeting onsite to discuss construction activities

6.5.2 VDC Construction and Mock-up Stage Products:

The products for the mock-up stage and the construction stage were similar, except the fact that for the mock-up stage, shop drawings were produced and sent to the timber suppliers by the VDC integrator (Figure 6-23), which due to quality control issues, was later modified to be included in the supplier's work package.

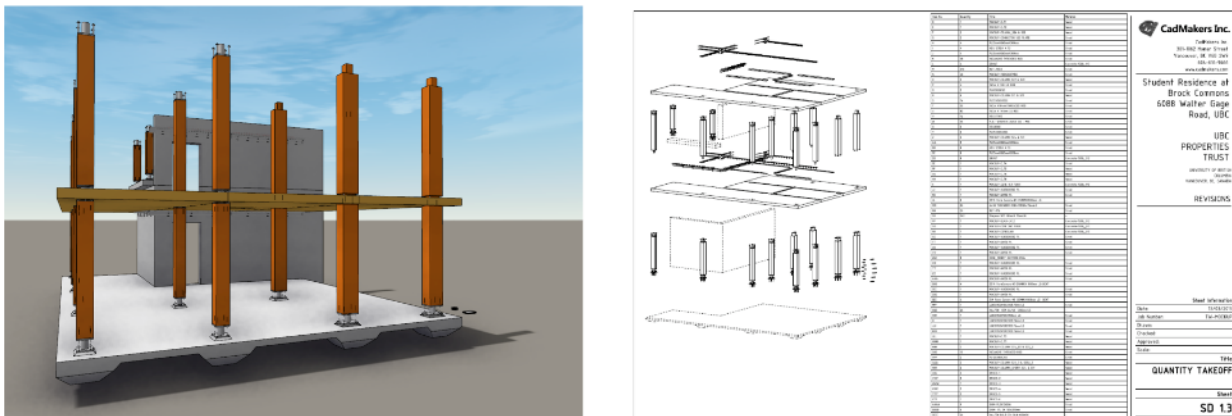

Figure 6-23 VDC model and shop drawing developed by the VDC integrator during mock-up stage (Courtesy of CadMakers)

The products included 4D sequencing videos for the construction processes and installations
 Figure 6-24, loading schedules for the trucks carrying the pre-fabricated elements and
 constructability and logistical analysis videos and documents, as shown in Figure 6-25 and
 Figure 6-26 below:

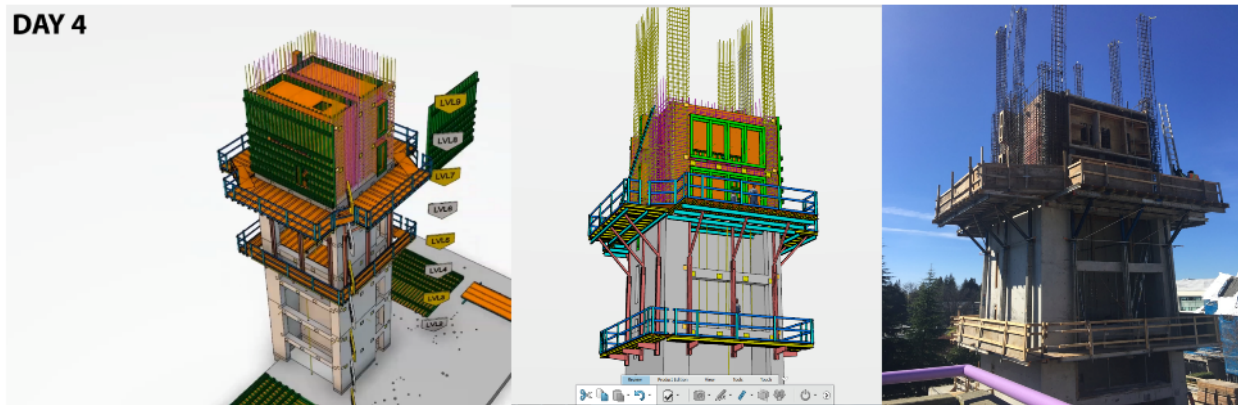

Figure 6-24 Construction sequencing 4D and VDC model for concrete cores (Courtesy of CadMakers)

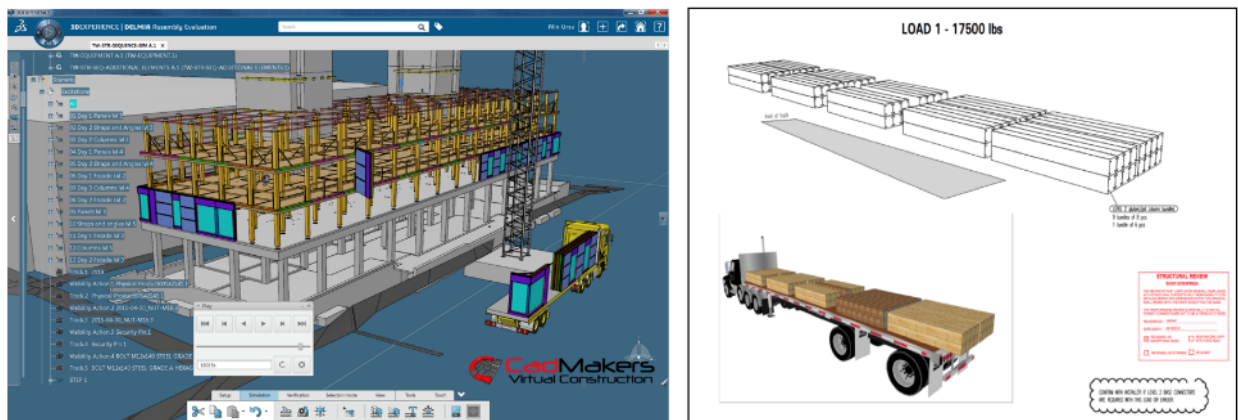

Figure 6-25 4D of loading and installing of the envelope panels and GLT columns

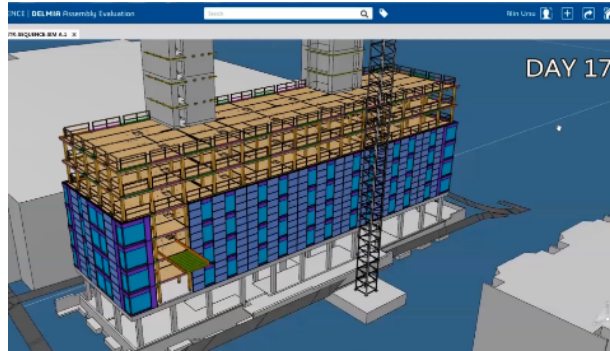

Figure 6-26 The "Outrigger" location and movement 4D for interior work

6.5.3 VDC Construction and Mock-up Stage Outputs:

The products produced by the VDC integrators at this stage were used to develop construction strategy documents and inform the team. Figure 6-27 highlights the temporary placement of columns before being installed on the CLT Slabs.

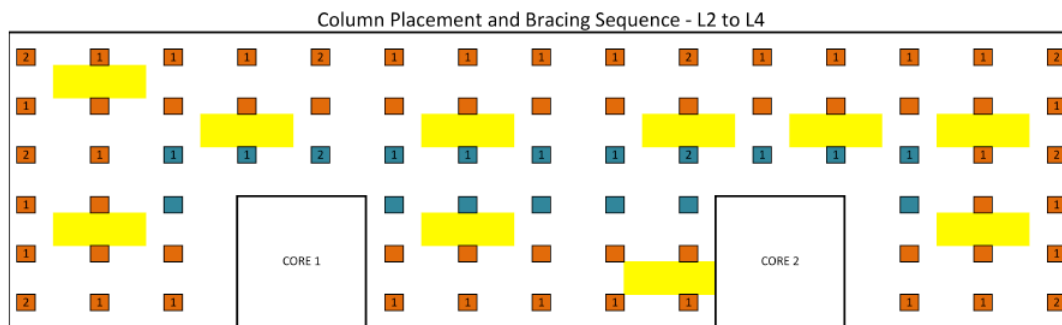

Figure 6-27 Construction strategy document highlighting the placement of column bundles (Courtesy of UrbanOne Builders)

These sequencing and 4D videos were then translated into numbers and codes on shop drawings to indicate their respective installation sequencing as shown in Figure 6-28.

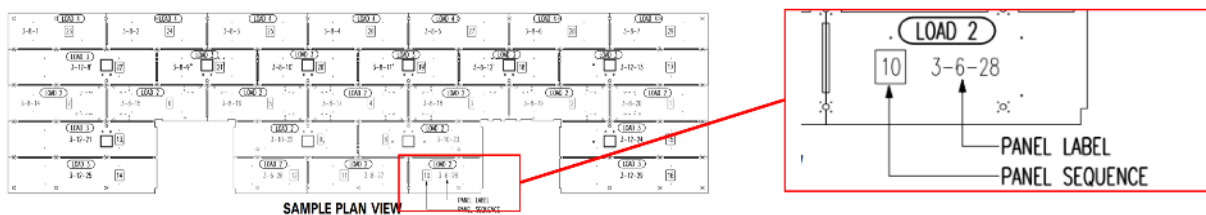

Figure 6-28 Installation sequencing of the CLT panels

Chapter 7: Conclusion

7.1 Lessons Learned

This thesis has been an in-depth case study on the use of innovation as a solution to a driver which is the use of an unconventional building material, timber. While a detailed documentation of the innovations in product and process of Brock Commons which is provided in chapter five may not be applicable to future tall timber construction projects, there are 12 categories of lessons learned that can be extracted and presented as the contribution of this thesis:

1. Extensive pre-planning translates to direct benefits in the field:

Many of the trades involved during the preliminary design stages did not have a contract at the time of the workshop. Regardless, their presence provided valuable feedback that dictated the direction of the design which later translated to better understanding of the project and better execution on-site. The idea with including the trades from the very early project onset was to ensure nothing is assumed about the constructability and everything in the budget estimations and schedule development were realistic.

The extra design and preconstruction time has proved to be valuable due to the saved construction time. “From a project developer’s perspective, the running cost is of construction is very high (approximately \$5,000/ day or \$150,000/ month [and can be] \$10,000/day in a higher project). The profit made by renting out 404 beds is approximately \$0.5M/ month. We spent [6] months longer in the design stages (14 months as opposed to a typical 8 month) to save three months of the construction time ... [resulting in] a huge benefit”(Olund, 2016).

2. Continuous and consistent communications amongst project team ensures tighter project control:

Weekly trade meetings, involving trades, the VDC integrator, the construction manager and designers, helped the project team determine a very detailed breakdown of work and sequencing of construction activities on site down to an hourly cycle to ensure the construction process is safe, efficient and that the schedule is aggressive, but obtainable. The presence of the site safety office both in all the trade meetings and while work was being commenced additionally ensured everybody was adhering to the procedures developed ahead of work.

3. Pre-fabrication is key to achieve project targets:

Cost and schedule targets, albeit aggressive, were achieved in large part due to the ease of assembly of pre-fabricated building components, as highlighted by the project manager repeatedly throughout the project. Part of the pre-planning exercise was to ensure that targeted building components could be pre-fabricated and then work towards detailing each element as necessary. The level of automation of the pre-fabrication process largely dictated the level of detail required by the suppliers. For instance, much more coordination work went into the CLT panels (placing each plumbing route or electrical conduit) than into the envelope panels, which were very repetitive. Of course, the typology of the building, lent itself well to this type of exercise. More time would have been required had the floor plans been different on every level.

The creation of standardized packages for the plumbing, based on Bills of Materials (BOMs) provided by the VDC integrators was beneficial but could have been developed further. While the level to which the plumbing subcontractor used, the prepared packages are to be determined when the work is fully finished, it is a fact that the mechanical room was fully prefabricated off site and assembled on site which shaved 2-3 months of on-site work.

When asked if more of the building could have been pre-fabricated, the project team mentioned that further exploration is needed. Items such as framing for demising walls, bathroom units and electrical cabinets could all have been pre-fabricated off site. This would however have increased crane usage and made management of hook time more onerous. In this case, emphasis was put on structure and envelope.

4. Pre-fabricated and non-prefabricated elements have different tolerances which needs mitigation:

Some questions arose around the interfacing between the pre-fabricated components, which had a tolerance of +/- 2mm and non-prefabricated elements, the concrete cores which had a tolerance level of +/- 50mm. Designers built-in sufficient leeway to accommodate larger tolerances, but this was an important consideration throughout design and construction. To overcome this, constant surveying was done when installing the “L” angles on the core among other elements. In the end, concrete cores showed a +/- 20mm variation. This was attributed to the double height formworks which made it a bit easier to maintain that margin as well as rigorous QA during and QC after each pour.

Working to tight tolerances even within traditional processes was achievable as was demonstrated with the concrete and interior type X dry walling.

5. There needs to be flexibility in design for prefabricated elements:

It was highlighted by the mass-timber supplier that it would have been plausible to manufacture all columns a couple of millimeters shorter, and then add shimming plates on site to fix the heights, instead of having to shave some of the newer products to make up for the height in a lower level. That being said, in this particular case, no corrective action had to be taken on the columns at any point in the construction (i.e. no shimming plates nor reduction in height or the columns)

6. Repetition supports a rapid learning curve:

As demonstrated in section 5.2, productivity rapidly adjusted after level three construction. The timber erectors learned how to use the crane better rather than do everything manually as they are used to in stick frame constructions which are generally working in much less heights and weights. They started slow but made the schedule, in fact they could have gone faster if other weather and fire measures and interior work would have caught up.

7. The presence of extensive QA/QC in the shop and on-site is crucial to success:

A lot of effort was put into QA/QC while the structure was being erected. There were heavy quality assurance and quality control measures in place. Indeed, procedures were in place to check all building elements produced against design requirements. Actual measurements were recorded both on the product, and on a separate sheet. Since the

superstructure installation is now completed, it is demonstrated that since all the pre-fabricated elements were built exactly within tolerances, it helped the construction process and the aggressive schedule was realized.

8. Use of Virtual Design and Construction (VDC) means and methods, including BIM, is key to enabling pre-fabrication:

VDC integrators were involved early in the project (see phase I report) and carried throughout the project. Typically, VDC integration is either absent in a project or tasks are divided up between the designers to hand in as part of their package submissions. This project was different in that the VDC integrators were hired directly by the owner (see below). Their role was to support the coordination of building elements during design and then interface with the trades to further develop and detail several of the building's key components, including the CLT panels and the plumbing. They were involved in all aspects of the planning and coordination of the project, including detailing the mock-up, producing highly detailed digital models of the CLT panels that were then transferred to the structural timber supplier and developing bills of materials for the mechanical trades. To do so, they worked directly with the designers, construction managers and trades to bring the virtual model of the building up to a very high level of detail. They helped the project team with budget estimations, structural design selection and construction process streamlining. The VDC integrator did all the sequencing detailing to the finishing detailing level, since with this project being so fast-tracked, there were no time for tender negotiations concurrent to timber installation.

9. The VDC integrator acting on behalf of the owner allows for better communication between the team:

To ensure that the VDC integrators could fulfill the role discussed in the point above, they were hired directly by the owner to act as facilitators throughout the project. This allowed access to the project team and facilitated flow of information as the VDC modelers were seen as representing the building's interest. It was mentioned during interviews with the project team members that nobody saw them as competition or dedicated to a specific trade or designer.

To further formalize the VDC integrators role within the project team, the owner required that project participants work and report to the VDC integrator. The VDC integrator was empowered by the owner to call upon the designers and trades directly to coordinate further details. These informal phone calls, emails and coordination meetings allowed the VDC integrator to determine areas of possible clashes or improvement and communicate it to the design team to further refine the design before the arrival of any single module on site. This constant involvement of the VDC integrator as an in-between person and owner's agent allowed to keep the virtual model alive and updated at all times.

The one draw-back with this means of communication was that in order for the model to be kept updated and the penetration coordination being finalized, the VDC integrator would require a higher level of detail from the designers, specifically the MEP designers, as they are generally used to laying out a general layout and having the trade be in charge of finalizing the MEP plans on site.

10. Obtaining buy-in from the trades increases ownership of the project:

Open and clear communication throughout the bidding and hiring process of the trades were key in ensuring the trades have a clear idea of their scope and responsibilities to avoid over or underestimation that can lengthen the schedule and incur extra costs. In order for the trades to provide detailed feedback, taking ownership for the project was key and the collaborative spirit was instilled in the team from the beginning. The trade knew the success of the project would directly reflect good on themselves and according to the PM also knew they had to step up in collaborative meetings if they didn't want to be the "Weakest link" in the team. This trade buy in also resulted in the what was deemed 'truer' prices given by the trades, which included less of a contingency, as they knew what was going to happen and much of the guesswork related to field coordination was removed. So far it seems the prices given were adequate and excessive expenditures are minimal. It is worth noting however, that this enthusiasm and buy-in was partly due to the fact that this building was to be "the tallest" and "the first" to utilize use of mass timber in conjunction with concrete to this extent. It is possible that even if all the same methods for increasing buy-in are implemented on a second project of this scope, the excitement and eagerness would not be as much. Figure 6-22 in the earlier chapter shows one of the routine meetings with all the trades present, and discussing a plan of action.

The area where trade buy-in and mentality was an issue was during the interior and finishing work session. According to the site senior project manager, the trades were not used to working within a very detailed and sequential schedule and were used to working at their own pace. This caused issues both because the trades would take longer to finish, and because of the sequential work, any delay from one trade would lead to considerable

hindrance of other trades' operations. While this is normal for most construction, in this project, due to the tight schedule and because the completion of the project is now fully dependent on the interior trades finishing on time, this had more importance.

11. Water, Fire and weather management is a priority as wood is more sensitive to those factors:

For water and weather management, the idea of using tarp to cover the panels were brought up. However, according to the PM, use of tarp is a safety hazard, and is also cluttering the work surface, therefore other water management systems were used which has been explained in detail earlier. Even in case of severe rainfall (which happened), the CLT panels will dry in 2days however excessive wetness and dryness will lead to changed mechanical properties of the CLT panels, so It should be minimized. The CLT installation can now be done in rainy weather due to all the lessons learned and the revised rainfall mitigation strategy.

Fire protection and weather management go hand in hand, so any adjustments in one needs to be checked against the other. This means since a lot of what fire protection deals with are the concrete topping and the type X drywall, if the sequencing of these are changed to allow for more rapid water mitigation, it needs to still satisfy the fire protection measures.

12. Modified Contracts with Trades are beneficial to the project:

Even though it is not specific to the nature of a mass timber building, the lack of operating elevators has made it very difficult to service inside trades. Initially, the schedule and plan was to have the elevators installed and be operating even through the timber element

assemblies. This meant the elevators were planned to work in conjunction with the existing outrigger system to service the building. However, according to the project manager, due to the elevator supplier not coming in time, the elevator is still not installed through the interior finishes stage.

According to the project manager, the one thing that could have helped the process for interior work would have been to have modified contracts. She believes having double the crew for each of the trades would have shaved off significant time from the schedule, even bringing it down to 3/4- 2/3 of what is currently is. It would have also helped keep sequencing on track as having more trades would have partially made up for the lack of shift in mentality for working with such tight deadlines and time commitments.

7.2 Summary of Innovations

This research has aimed to capture how use of an unconventional high-rise building material can be successful through using innovative methods. To this end, UBC Brock Commons was used a case study, and the experiences and processes undertaken by the project team was documented in depth and presented as the finding of the research along with comments on takeaways.

The innovations identified in the project, has been defined as any building element that has had a construction method outside of standard practice. Therefore, the following elements were identified, along with how they deviated from typical methods:

1. **Construction Cores:** While using concrete is very standard in the industry at least in the Lower Mainland, the construction of two free standing tall structures, with only access from within the cores, required a modified system different from typical cast in place concrete projects.

2. **Timber Floors and Columns:** On top of timber not being the standard building material for columns and floors in high-rise construction, the pre-fabrication of the MTPs required extensive pre-planning and modifications in the standard workflows.
3. **Envelope Panels:** The pre-fabrication of envelope panels is not standard practice in the industry and hence capturing the process was of value

Once each of the elements were analyzed and innovative solutions were flagged the use of innovation for the process was further dissected. The various phases of project VDC was used in that made up the second SO of this research were:

1. **Preliminary Design Phase:** In this phase, the VDC was used to create a base VDC model to use for basic quantity take-offs, cost estimations and project approval studies. The model was additionally used to create the basic 2d drawings for the structural engineers to further develop based on hand sketches provided to the VDC integrators.
2. **Design Development Phase:** During design development, the model was further updated to include the latest details and represent the latest set of drawings at any given time. The model was then used to coordinate the locations of mechanical cannings in the concrete slab against the steel reinforcements and conduct rigorous inter-disciplinary clash detections. Finally, the model was heavily used to finalize the MEP for the building, to allow for pre-fabrication of mechanical spools in floor and the mechanical room. It was also heavily used to determine the exact openings in the CLT slabs in preparation for CNC machines.
3. **Construction Phase:** During the construction, the VDC integrators created detailed 4d sequencing videos, and presented them in trade meetings to two ends. First to demonstrate the workflow and minimize uncertainty on site that could lengthen the

schedule and drive up the costs, and to incorporate trade feedback into the sequencing and plans.

Finally, the overarching lessons learned from the project, that can be taken away and applied to future buildings of the same scale were listed and elaborated on. This research presents a comprehensive glance behind what is required to make the idea of tall timber construction a reality.

7.3 Limitations and Future Work

Since this case study is submitted ahead of the occupancy phase, final comments on building performance, and lessons learned for the “interior” and “finishes” are incomplete. With the innovative processes identified, it is the recommendation of the author that future work and analysis be done on examining the construction site communications (RFI, SI, CO) and compare them with those of more traditional method construction sites to identify areas in which the innovation has increased and decreased efficiencies. Additionally, a comprehensive case study of commissioning, post-construction and occupancy is recommended to assess how the building can perform as a product since the bulk of the analysis presented here are regarding the process innovation.

Bibliography

- Abrahamsen, B. R., & Malo, K. A. (2014). Structural design and assembly of “treet” - A 14-storey timber residential building in Norway. *NEW ZEALAND TIMBER DESIGN*, 22(3), 3–10.
- Adeli, H. (2009). Vision for civil and environmental engineering departments in the 21st century. *Journal of Professional Issues in Engineering Education and Practice*, 135(1), 1–3.
[https://doi.org/10.1061/\(ASCE\)1052-3928\(2009\)135:1\(1\)](https://doi.org/10.1061/(ASCE)1052-3928(2009)135:1(1))
- APA. (2011). *Standard for Performance-Rated Cross-Laminated Timber. October* (Vol. 320).
- Barber, D., & Gerard, R. (2015). Summary of the fire protection foundation report - fire safety challenges of tall wood buildings. *Fire Science Reviews*, 4(1), 5.
<https://doi.org/10.1186/s40038-015-0009-3>
- Barnes, P., & Davies, N. (2014). *BIM in Principle and in Practice*.
<https://doi.org/doi:10.1680/bimpp.60920>
- Becerik, B. (2004). A review on past , present and future of web based project management & collaboration tools and their adoption by the US AEC industry. *International Journal*, 2(3), 233–248.
- Bølviken, T., & Koskela, L. (2016). Why Hasn’t Waste Reduction Conquered Construction? In *24th Annual Conference of the International Group for Lean Construction*. Retrieved from <http://www.iglc.net/papers/details/1362>
- Bralla, J. (1996). *Design for excellence*. New York: McGraw-Hill.
- Brundtland, G. H. (1987). *Our Common Future. Oxford Paperbacks*.
<https://doi.org/10.2307/633499>
- Burrows, J. (2014). *Canadian Wood-Frame House Construction. Canada Mortgage and*

Housing Corporation (CMHC) (Vol. 3).

Canadian Wood Council (CWC). (2013). 2013 Tall Wood structure demonstration Projects/ a

Request for an expression of Interest. Retrieved March 3, 2017, from

<http://cwcdemoproject.ca/fr/>

Dassault Systemes. (n.d.). Architecture, Engineering & Construction Collaborative and

industrialized construction. Retrieved April 4, 2017, from

<https://www.3ds.com/industries/architecture-engineering-construction/overview/>

Dulaimi, M. F., Nepal, M. P., & Park, M. (2005). A hierarchical structural model of assessing

innovation and project performance. *Construction Management and Economics*, 23(July),

565–577. <https://doi.org/10.1080/01446190500126684>

Farinha, F., Gonçalves, R. J., & Garção, A. S. (2007). Integration of cooperative production and

distributed design in AEC. *Advances in Engineering Software*, 38(11–12), 772–779.

<https://doi.org/10.1016/j.advengsoft.2006.08.038>

Forestry Innovation Investment (FII). (2016). 2016 Customer Market Acceptance Research.

Retrieved from

http://www.bcfii.ca/system/files/reports/public/fii_summary_leger_2016_market_acceptance_survey.pdf

Forestry Innovation Investment (FII), & Binational Softwood Lumber Council (BSLC). (2014).

Summary Report: Survey of International Tall Wood Buildings.

Formoso, C., Bølviken, T., Rooke, J., & Koskela, L. (2015). A Conceptual Framework for the

Prescriptive Causal Analysis of Construction Waste. *23rd Annual Conference of the*

International Group for Lean Construction, 454–461. Retrieved from

<http://www.iglc.net/Papers/Details/1162>

- Foster, R. M., Reynolds, T. P. S., & Ramage, M. H. (2016). Proposal for Defining a Tall Timber Building. *Journal of Structural Engineering*.
- Gasparri, E., Lucchini, A., Mantegazza, G., & Mazzucchelli, E. S. (2015). Construction management for tall CLT buildings: From partial to total prefabrication of façade elements. *Wood Material Science and Engineering*, *10*(3), 256–275.
<https://doi.org/10.1080/17480272.2015.1075589>
- Green, M., & Karsh, E. (2012). The Case for Tall Wood Buildings. *Mgb Architecture + Design*, 22–23.
- Holt, R., & Barnes, C. (2010). Towards an integrated approach to “Design for X”: an agenda for decision-based DFX research, *21*(2), 123–136.
- Ilozor, B. D. (2009). Differential management of waste by construction sectors: a case study in Michigan, USA. *Construction Management and Economics*, *27*(February 2015), 763–770.
<https://doi.org/10.1080/01446190903117769>
- Khanzode, A., Fischer, M., Reed, D., & Ballard, G. (2006). A Guide to applying the principles of virtual design & construction (VDC) to the lean project delivery process. *CIFE, Stanford University*, ..., (December), 1–47. Retrieved from
<http://www.stanford.edu/group/CIFE/online.publications/WP093.pdf>
- Koo, K. (2013). *A study on historical tall-wood buildings in Toronto and Vancouver*.
- Koskela, L. (1992). *Application of the new philosophy to construction*. Center for Integrated Facility Engineering. Retrieved from
<http://citeseerx.ist.psu.edu/viewdoc/download?doi=10.1.1.15.9598&rep=rep1&type=pdf>
- Kunz, J., & Fischer, M. (2012). Virtual Design and Construction: Themes, Case Studies and Implementation Suggestions. *CIFE Working Paper*, *97*(Version14), 50. Retrieved from

<http://www.stanford.edu/group/CIFE/online.publications/WP097.pdf>

Loosemore, M. (2015). Construction Innovation: Fifth Generation Perspective. *Journal of Management in Engineering*, 31(6), 4015012. [https://doi.org/10.1061/\(ASCE\)ME.1943-5479.0000368](https://doi.org/10.1061/(ASCE)ME.1943-5479.0000368)

Naturally Wood. (2015). Wood Innovation & Design Centre Case Study. Retrieved from http://www.naturallywood.com/sites/default/files/documents/resources/wood-innovation-design-centre_0.pdf

NBCC. (2015). National Building Code of Canada. *National Research Council, Ontario, ON, Canada.*

OECD. (2010). *Measuring Innovation: A New Perspective.*

Brock Commons Project Background Interview [Interview by Wood Works Debrief!]. (2016, December 13).

Öqvist, R., Ljunggren, F., & Gren, A. (2012). On the uncertainty of building acoustic measurements - Case study of a cross-laminated timber construction. *Applied Acoustics*, 73(9), 904–912. <https://doi.org/10.1016/j.apacoust.2012.03.012>

Pahl, G., Beitz, W., Feldhusen, J., & Grote, K.-H. (2007). *Engineering Design: A Systematic Approach. A NASA STI/Recon Technical Report.* <https://doi.org/10.1007/978-1-84628-319-2>

Poirier, E., Tanner, T., Staub-French, S., Fallahi, A., & Moudgi, M. (2016). *UBC Tall Wood Building Case Study – (Design and Pre-construction Phase).*

Pries, F., & Janszen, F. (1995). Innovation in the construction industry: the dominant role of the environment. *Construction Management and Economics*, 13(1), 43–51. <https://doi.org/10.1080/01446199500000006>

- Richard, R. B. (2005). Industrialised building systems: Reproduction before automation and robotics. In *Automation in Construction* (Vol. 14, pp. 442–451).
<https://doi.org/10.1016/j.autcon.2004.09.009>
- Robinson, T., Hallova, A., Spiritos, J., & Roelofs, M. (2016). New heights for renewables: The US Tall Wood Building competition. *CTBUH Journal*, (1).
- Seaden, G., Guolla, M., Doutriaux, J., & Nash, J. (2003). Strategic decisions and innovation in construction firms. *Construction Management and Economics*, 21(6), 603–612.
<https://doi.org/10.1080/0144619032000134138>
- Seaden, G., & Manseau, A. (2001). Public policy and construction innovation. *Building Research & Information*, 29(3), 182–196. <https://doi.org/10.1080/09613210010027701>
- Sexton, M., & Barrett, P. (2003). Appropriate innovation in small construction firms. *Construction Management & Economics*, 21(6), 623–633.
<https://doi.org/10.1080/0144619032000134156>
- Slaughter, S. (1993). Innovation and learning during implementation: a comparison of user and manufacturer innovations. *Research Policy*, 22(1), 81–95. [https://doi.org/10.1016/0048-7333\(93\)90034-F](https://doi.org/10.1016/0048-7333(93)90034-F)
- Szeto, W. Y., Wang, Y., & Wong, S. C. (2014). The Chemical Reaction Optimization Approach to Solving the Environmentally Sustainable Network Design Problem. *Computer-Aided Civil and Infrastructure Engineering*, 29(2), 140–158.
- Tahan, N., & Zangerl, M. (2013). LCT ONE. *Wood Design & Building*.
- Tam, V. W. Y., & Hao, J. J. L. (2014). Prefabrication as a mean of minimizing construction waste on site. *International Journal of Construction Management*, 14(2), 113–121.
<https://doi.org/10.1080/15623599.2014.899129>

- Tatum, C. B., Vanegas, J. A., & Williams, J. M. (1986). *Constructability Improvement Using Prefabrication, Preassembly, and Modularization*. Dept. of Civil Engineering, Stanford University.
- UBC Campus and Community Planning. (2010). *UBC Vancouver Campus Plan*. Vancouver.
- UBC Public Affairs. (2015). New UBC student residence to be among world's tallest wood buildings.
- Urban One Builders. (2016). UBC Brock Commons: Construction Site Safety Document. Vancouver.
- Van De Kuilen, J. W. G., Ceccotti, A., Xia, Z., & He, M. (2011). Very tall wooden buildings with Cross Laminated Timber. In *Procedia Engineering* (Vol. 14, pp. 1621–1628).
<https://doi.org/10.1016/j.proeng.2011.07.204>
- Veshosky, D. (1998). Managing Innovation Information in Engineering and Construction Firms. *Journal of Management in Engineering*, 14(1), 58–66. [https://doi.org/10.1061/\(ASCE\)0742-597X\(1998\)14:1\(58\)](https://doi.org/10.1061/(ASCE)0742-597X(1998)14:1(58))
- Watson, J. (2011). Innovation in the construction sector. In *Managing the professional practice in the built environment*. Wiley-Blackwell.
- Winch, G. (2003). Models of manufacturing and the construction process: the genesis of re-engineering construction. *Building Research & Information*, 31(2), 107–118.
<https://doi.org/10.1080/09613210301995>
- Winch, G. M. (2003). How innovative is construction? Comparing aggregated data on construction innovation and other sectors – a case of apples and pears. *Construction Management and Economics*, 21(6), 651–654.
<https://doi.org/10.1080/0144619032000113708>

- Wood, H. L., Piroozfar, P., & Farr, E. R. P. (2014). Understanding complexity in the AEC industry. In *Proceedings 29th Annual Association of Researchers in Construction Management Conference, ARCOM 2013* (pp. 859–869). Retrieved from <http://www.scopus.com/inward/record.url?eid=2-s2.0-84911439852&partnerID=tZOtx3y1>
- Wood Frame Construction. (n.d.). Retrieved April 10, 2017, from <http://www.understandconstruction.com/wood-framed-construction.html>
- Zhang, J., Long, Y., Lv, S., & Xiang, Y. (2016). BIM-enabled Modular and Industrialized Construction in China. In *Procedia Engineering* (Vol. 145, pp. 1456–1461). <https://doi.org/10.1016/j.proeng.2016.04.183>