

# Development of Rear Entry HUT/PLSS Design for Aouda.X Spacesuit Simulator



Anjana Jegatheesan

**Space Engineering, master's level (120 credits)  
2018**

Luleå University of Technology  
Department of Computer Science, Electrical and Space Engineering

---

**Masters Thesis**  
**Development of Rear Entry HUT/PLSS Design**  
**for Aouda.X Spacesuit Simulator**

---



**Anjana Jegatheesan**

*Luleå University of Technology*

***Erasmus Mundus Joint European Master in Space Science  
and Technology***

*Department of Computer Science, Electrical and Space Engineering*

**Supervisor: Dr. Gernot Grömer**

*Österreichisches Weltraum Forum - The Austrian Space Forum*

**Examiner: Dr. Lars-Göran Westerberg**

*Luleå University of Technology*

**January 18, 2018**



# Disclaimer

This project has been funded with support from the European Commission. This publication (communication) reflects the views only of the author, and the Commission cannot be held responsible for any use which may be made of the information contained therein.



Co-funded by the  
Erasmus+ Programme  
of the European Union



# Abstract

**Keywords:** Rear Entry Spacesuit, HUT, PLSS, Aouda.X, Donning, Prototype development

The Aouda.X Space suit simulator, developed by The Austrian Space Forum (ÖWF) currently consists of a system that weighs 48 kg of which nearly 57% is comprised of the Suit's HUT (Hard Upper Torso), PLSS (Portable Life Support System) and OBDH (On-board data handling). In addition to this, the current configuration requires 3 hours of assisted donning/doffing. To improve the ergonomics of the design, a relatively lighter HUT/PLSS design prototype with efficient donning capabilities, preferably self-donning, must be developed. This issue can be addressed by proposing a Rear – Entry Design that when implemented on the Aouda.X, can potentially ease these impediments.

This study aims at identifying a suitable Rear entry closure design for the current configuration of Aouda.X based on planetary suit performance indicators and operational requirements. The Aouda.X rear entry design is also targeted to be compatible with the NDX -Suitport developed by the University of North Dakota's Human Spaceflight Laboratory. The thesis work comprises of the development of a suitable methodology to distinguish a rear entry design for the HUT and PLSS of the spacesuit simulator with the identification of a self-sealing/locking mechanism based on these requirements. A full scale CAD model of the HUT and PLSS with optimal dimensions of compatibility for the Spacesuit with the suitport is designed as a result of this study. Static load bearing analysis is performed to validate the feasibility of the structure and make suitable recommendations for choice of materials. Methods for further improvement for rear entry suit development are outlined.

# Acknowledgements

At this delightful moment of having completed this thesis report, I extend my sincere thanks to Luleå University of Technology for providing me this opportunity and necessary funds to carry out my research work in Innsbruck. My first and foremost gratitude goes to Österreichisches Weltraum Forum - The Austrian Space Forum who had selected me for this research work on their Spacesuit simulator.

I would like to express my biggest gratitude to those three souls who were always at the Spacesuit Lab , whether rain or shine, Dr. Gernot Grömer, who was my supervisor as well, Sophie Gruber and Max Lell without whom my days at the lab would not have been any more amusing than it already was. Our Spacesuit "Wonderland" Lab is never the same without you guys especially. I must also not forget Sebastian Sams who was always ready to open up the PLSS and start a detailed explanation about everything Suit related, never once getting bored as well as Benjamin Knaus and Julia Neuner who assisted me with structural work on Aouda. Their suggestions coupled with Dr. Gernot's guidance were vital for the outcome of the project. My thanks to Olivia Haider for always helping me with any media related work , answering my constant questions during the Analog Basic Mission Training , for giving me her awesome bike without which I probably would not have explored around Alpine Innsbruck and thanks of course to everyone else at the lab who always had welcoming bright smiles on their faces. Endless Sci-fi discussions with you people coupled with a ton of humour was something to look forward to everyday at work. Hoping to see you again for AMADEE-18!

I would also like to thank my examiner Dr. Lars-Göran Westerberg and my course director Dr. Victoria Barabash and the administration from Luleå University of Technology for their understanding of unprecedented delays faced during the course of the thesis, for their constant support and advice as well as for letting me continue this work for an extended duration. Many thanks to Dr. Thomas Kuhn from LTU who offered to lend his 3D printer during the prototype phase.

My hearty thanks to Mr. Tim Lexen , an experienced R&D mechanical engineer from Minnesota who has a passion for developing hands on Space projects. His paper on *Inside Hand Access for a Surface EVA suit* immediately caught my attention due to some innovative designs and concepts mentioned there after which I decided to implement some of his ideas on Aouda. Many thanks to him for answering each one of my emails and questions without delay. His detailed drawings and explanations were a great help when I was struggling with some design configurations.

Gratitude goes out to Dr. Pablo de Leon and Nanette Valentour from University

---

of North Dakota's Human Spaceflight Laboratory who extended their full cooperation and timely assistance in providing me details of their NDX spacesuit and Suitport and their interest to further continue working with me to achieve a prospective NDX- Aouda collaboration. Many thanks to my good friend, Rusty Goh for providing me with instrumental advice during the CAD modelling and analysis phase.

Finally, I would extend my deepest gratitude to my Spacemaster Round 11 friends who have been instrumental in sharing their knowledge and help in various technical fields as well as a lot of memorable experiences during my Erasmus years. Thanks to you guys, I have grown in both mind and spirit and it has been the best educational experience so far! My friends and my family back home who are always ready to pick my brain and encourage me further about what's out there in Space, deserve appreciation for their support throughout my thesis work.

The list is unending but a final thanks to all those whose names I could not mention here and I hope to meet all of you in the near future!



# Contents

<b>1</b>	<b>Introduction</b>	<b>1</b>
1.1	Heritage of Extra Vehicular Activity (EVA) and Spacesuits . . . . .	1
1.1.1	Evolution of Spacesuits . . . . .	2
1.2	Parts of a Spacesuit . . . . .	4
1.3	Mars Planetary EVA and Exploration . . . . .	5
1.4	Mars Analog Missions and Spacesuit Simulators . . . . .	7
1.5	Aouda.X Spacesuit Simulator - Current State of the Art . . . . .	9
1.6	Statement of research problem . . . . .	9
1.7	Literature research . . . . .	11
1.8	Research aims, scope and deliverables . . . . .	13
<b>2</b>	<b>Methodology</b>	<b>15</b>
<b>3</b>	<b>Aouda.X-System Configuration of HUT/PLSS</b>	<b>19</b>
3.1	System Overview . . . . .	19
3.2	Performance Envelope . . . . .	20
3.3	HUT Structure . . . . .	20
3.4	PLSS Structure . . . . .	21
<b>4</b>	<b>Performance and Test Requirements</b>	<b>23</b>
4.1	HUT/PLSS requirements . . . . .	24
4.1.1	Design goals . . . . .	26
4.2	Suitport compatibility . . . . .	27
4.2.1	Suitport concept . . . . .	27
4.2.2	NDX Suitport . . . . .	27
4.3	Test requirements . . . . .	28
4.3.1	Task analysis . . . . .	29
4.3.2	Performance metrics . . . . .	29
<b>5</b>	<b>Design Considerations and Results</b>	<b>33</b>
5.1	Challenges to System Design and Weight Issues . . . . .	33
5.2	HUT frame design considerations . . . . .	34
5.2.1	Contemporary design considerations . . . . .	34
5.2.2	HUT Design features and mechanism . . . . .	40
5.3	CAD model of HUT . . . . .	46

---

5.4	HUT/PLSS Assembly Configuration . . . . .	49
5.4.1	PLSS Packaging concepts . . . . .	49
5.5	Anthropometric Sizing . . . . .	52
5.6	Suitport docking arrangements . . . . .	57
<b>6</b>	<b>Analysis</b>	<b>63</b>
6.1	Finite Element Modeling . . . . .	63
6.2	Finite Element Analysis . . . . .	63
6.2.1	With 1G acceleration of gravity, calculate the maximum vertical displacement of the HUT and the stress generated on the hatch entry . . . . .	64
6.2.2	With vertical force of 300N on hatch entry, calculate the maximum vertical displacement of the HUT and the stress generated on the hatch entry . . . . .	66
6.2.3	Material Selections . . . . .	67
6.2.4	Further Material Recommendations . . . . .	67
<b>7</b>	<b>Prototype Development</b>	<b>71</b>
<b>8</b>	<b>Conclusion and Further work</b>	<b>73</b>
<b>A</b>	<b>NDX EVA Airlock- Draft</b>	<b>77</b>
<b>B</b>	<b>HUT- Draft</b>	<b>79</b>
<b>C</b>	<b>PLSS- Draft</b>	<b>81</b>

# List of Figures

1.1	First known Spacesuit . . . . .	3
1.2	First pressure suit . . . . .	3
1.3	NASA's Spacesuits <i>from left to right</i> : Mercury, Gemini, Apollo, Shuttle EMU . . . . .	4
1.4	The Russian Orlan and Chinese Feitian Spacesuits . . . . .	5
1.5	HUT and PLSS developed by NASA . . . . .	6
1.6	MARS 2013 – Morocco Mars Analog Field Simulation by ÖWF . . . . .	8
1.7	Aouda.X Spacesuit and its major components . . . . .	10
1.8	Donning technique for Rear Entry Suits . . . . .	11
1.9	Spacesuit entry types . . . . .	12
2.1	Project Methodology Workflow Diagram . . . . .	18
3.1	Empty HUT (configuration early 2014, here without aluminium reinforcements on the shoulders) . . . . .	21
4.1	Line drawing of the front and back views of the Orlan D Spacesuit . . . . .	25
4.2	Exoskeletons for arms and legs . . . . .	25
4.3	An astronaut entering a spacesuit through a suitport . . . . .	27
4.4	<i>Left</i> : Suitport assembly that connects to the NDX-2 and Rover mount and Suitport dock. <i>Right</i> : Dome section of the space suit portion of the Suitport showing a mock up of the PLSS fitting. . . . .	28
4.5	EVA Access procedures using the Suitport, adapted from NASA TM-86856. . . . .	28
4.6	Climbing test, kneeling, bending forward and backward test . . . . .	30
4.7	Walking on inclined surface and standing posture . . . . .	30
5.1	General dimensions and comparison of Orlan-DMA and Orlan-M HUT . . . . .	35
5.2	Comparison between architecture of EVA 2000 suit and Orlan DMA ( <i>left</i> ) and Initial Zvezda prototype for arms and rear entry testing ( <i>right</i> ) . . . . .	36
5.3	ZPS Mark III hard torso shell ( <i>left</i> ) and Rear entry closure ( <i>right</i> ) . . . . .	36
5.4	NDX-2 HUT ( <i>left</i> ) and Helmet, Rear and Waist rings ( <i>right</i> ) . . . . .	37
5.5	I-Suit HUT ( <i>left</i> ) and Rear entry closure design ( <i>right</i> ) . . . . .	37
5.6	Movement of shoulder . . . . .	38
5.7	Z-2 HUT Shell ( <i>left</i> ) and Z-2 Suit 3-D printed prototype design ( <i>right</i> ) . . . . .	39

5.8	Comparison of Rear Entry Openings in Inches . . . . .	40
5.9	Front and Side cross sectional view of proposed Rear entry HUT . . .	41
5.10	Inside hand access mock up frame . . . . .	43
5.11	Skeletal frame of designed HUT . . . . .	43
5.12	Rear entry hatch - right side perspective and outward tilted mode . .	44
5.13	Locking mechanism consisting of a tongue - groove flange and trun- nion and mounting brackets . . . . .	45
5.14	Front- isometric view of designed HUT . . . . .	47
5.15	Back- isometric view of designed HUT . . . . .	47
5.16	Front - isometric view of designed HUT without scye extrusion . . . .	48
5.17	Back- isometric view of designed HUT without scye extrusion . . . .	48
5.18	( <i>from left to right</i> ) Foam Supported PLSS, Motherboard Packaging Concept and LEGO™ Packaging Concept . . . . .	50
5.19	PLSS configuration of the Orlan ( <i>left</i> ) and I-suit ( <i>right</i> ) . . . . .	51
5.20	NDX Suitport configuration . . . . .	51
5.21	PLSS inside view . . . . .	52
5.22	Isometric view of assembly with scye . . . . .	53
5.23	Side view of assembly without scye extrusion . . . . .	54
5.24	Stand overhead: Front view ( <i>left</i> ) and Side view( <i>right</i> ) . . . . .	55
5.25	Arms extended: Front view ( <i>left</i> ) and Isometric view( <i>right</i> ) . . . . .	56
5.27	Bending while working: Front view ( <i>left</i> ) and Side view( <i>right</i> ) . . . .	56
5.26	Kneeling on two knees: Front view ( <i>left</i> ) and Isometric view( <i>right</i> ) . .	57
5.28	Donning technique . . . . .	58
5.29	Example of the guide rails (purple) with pins (silver) ( <i>left</i> ) and Ex- terior seat to assist crewmember with alignment ( <i>right</i> ) . . . . .	59
5.30	Cross Section of Mark III latching tab concept showing the inflatable seal (red) and latching tab chain (gold) ( <i>left</i> ) and Navy dog detail showing disengaged and engaged shaped dogs (green) and the detents (blue) can assist in alignment and latching ( <i>right</i> ) . . . . .	59
5.31	Interlocking flanges bulkhead detail ( <i>left</i> ) and Detail of the multi- latch concept showing a single latch (green), designed so that they all go overcenter when engaged to secure the PLSS front (aqua). The activator ring (red) slides back and forth in the guide rod (yellow) ( <i>right</i> ) . . . . .	60
5.32	Marman Clamp detail showing engagement that assists in alignment and latching ( <i>left</i> ) and Marman Clamp mockup using wooden clamp, pulleys and rollers ( <i>right</i> ) . . . . .	61
6.1	Finite Element Model with force loading, gravity and fixed constraint	64
6.2	Displacement of S-Glass Fiber Composite HUT under 1G . . . . .	64
6.3	Stress deformation of S-Glass Fiber Composite HUT under 1G . . . .	65
6.4	Displacement of Kevlar HUT under 1G . . . . .	65
6.5	Stress deformation of Kevlar HUT under 1G . . . . .	65
6.6	Displacement of S-Glass Fiber Composite HUT under 300N . . . . .	66

6.7	Stress deformation of S-Glass Fiber Composite HUT under 300N . . .	66
6.8	Displacement of Kevlar HUT under 300N . . . . .	67
6.9	Stress deformation of Kevlar HUT under 300N . . . . .	67
7.1	Front and back views of 3D printed HUT . . . . .	71
7.2	Front and back views of 3D printed PLSS . . . . .	72

# List of Tables

- 3.1 Aouda.X System Mass overview . . . . . 20
- 4.1 Summary of Requirements . . . . . 31
- 5.1 EMU Weight History . . . . . 34
- 5.2 Dimensions of EVA space suit rear entry hatches . . . . . 39
- 5.3 Anthropometric dimensional data for an American male in 1-G conditions . . . . . 54
- 6.1 Material Properties and Mass of HUT/PLSS . . . . . 68
- 6.2 Comparison rating chart of Glass, Aramid and Carbon Fibre : E=Excellent, G=Good, P=Poor, F=Fair . . . . . 69



# Chapter 1

## Introduction

The Polish author Stanislaw Lem noted: “*there are no answers, only choices.*” When it comes to space suit engineering, a more accurate maxim could not be found. There are, and will be, many different approaches to lunar and Mars surface EVA investigated in the years to come. In systems engineering there is seldom one precise solution for a problem, especially if engineering for human physiology. Instead, there are a succession of technical trade-offs that must be studied and compared in order to ascertain what the most appropriate solutions available to the designer/engineer are, given the requirements and limitations s(he) must address. Since we are dealing with human anthropometry it should also be borne in mind that space suit enclosure design, and especially fabrication, is as much an art as a science. Accordingly, design approaches will draw from a history of technical choices and skilled design arts that have evolved in the United States and Russia since the 1960s. In addition, we must also draw from the most recent discoveries in materials sciences and processes [*LHarris et al.*].

This chapter gives an overview of the evolution and types of Spacesuits and how the research problem under study will be approached in this thesis work.

### 1.1 Heritage of EVA and Spacesuits

Since the beginning of human exploration above Earth’s atmosphere, our main challenge has been to supply the explorer with the basic necessities for life support that nature normally provides. Unprotected by a spacecraft, anyone encountering the near-vacuum of space would survive only a few minutes. Body fluids would vaporize in the absence of pressure and an atmosphere, and gas that would quickly expand in the lungs and other tissues would prevent circulation and respiration [*Newman, 2007*].

An EVA is identified as any manned space procedure or process performed outside the protective environment of a same habitat or space vehicle. This activity requires life support in conjunction with a pressurised, flexible enclosure. The ‘enclosure’ is referred to as an EVA suit, or in layman’s terms, a space suit [*Harris, 2001*].



A Spacesuit is the overall term for equipment that provides a cosmonaut/astronaut the required environmental protection and life support during any part of a space mission and consists of the suit enclosure proper and the Life Support System (LSS) components arranged on it. It is more than a set of clothes astronauts wear on spacewalks. It protects the astronaut from the dangers of being outside in space and a fully equipped spacesuit is really a one-person spacecraft. It provides its occupant from several harsh conditions in Space such as extreme temperature variations (-120°C to 120°C), micrometeoroids and radiation. They also contain oxygen to breathe, provide stable internal pressure and mobility, communication systems, waste collection and water to drink while they are in the vacuum of Space.

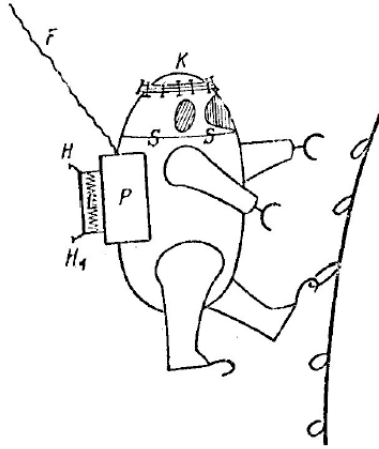
### 1.1.1 Evolution of Spacesuits

It is impossible to know when the need for spacesuits in outer space first became apparent. Fictionalized accounts of space travel from 165 A.D. through the early nineteenth century envisioned other-worldly adventures undertaken in unpressurised sailing vessels, balloons, and even by bird [Ordway *et al.*, 1992]. The first mention of spacesuits in fiction is found in Jules Verne's *From the Earth to the Moon*, where Verne describes spacesuits similar to those developed during Project Apollo [Kozloski, 1994]. K.E. Tsiolkovsky, the father of cosmonautics, first wrote of spacesuits as an engineering possibility in his 1926 work *Exploration of the Universe with Reaction Machines*. In this prescient work, Tsiolkovsky describes the basic functions of modern spacesuits: pressure production, oxygen delivery, contaminant removal, thermal control, mobility, and protection from the sun's rays [Blagonravov, 1954]. Working independently, German visionary Hermann Oberth described the basic design of a spacesuit in 1929 [Oberth, 1972]. See Fig 1.1

*“I would make them of thin polished tin and, in principle, similar to the deep-sea divers' equipment already in use today. For hands, I would attach claws. The feet could have hooks with which the diver can hold on to the cables or rings especially attached for this purpose to the projections of the rocket. . . I would embed the joints in a balloon of canvas lined with a thin layer of rubber on the inside. The whole diver's equipment could be tested before the ascent by sticking it into a somewhat large deep-sea diver's suit and using the air hose of the deep sea equipment to evacuate the space between the two suits.”*

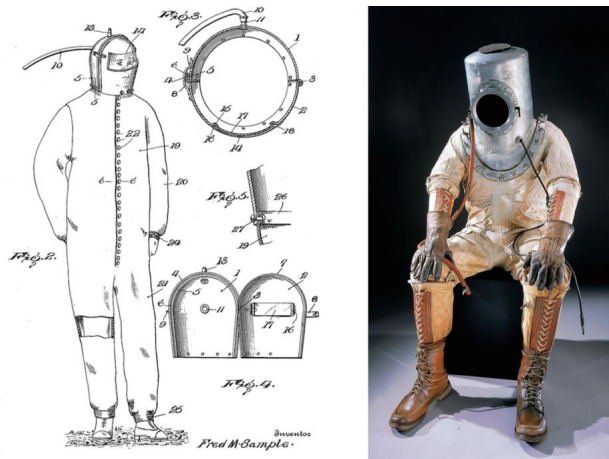
As pilots flew to greater and greater heights during the modern era of flight, people had to don pressure suits to provide oxygen when the air became too thin. Balloonists and, later, airplane pilots were the first innovators of such clothing. Fred M. Sample patented the first pressure suit in the US on Jul. 16, 1918 [Mann, 2011] as seen in Fig 1.2.

It was meant *“for supplying air to aviators when making flights at high altitudes or to travellers crossing high mountains.”* Fabricated from an elastic material, the invention shares many characteristics with modern spacesuits, including an airtight body suit that completely encloses the wearer, a helmet that can be readily opened



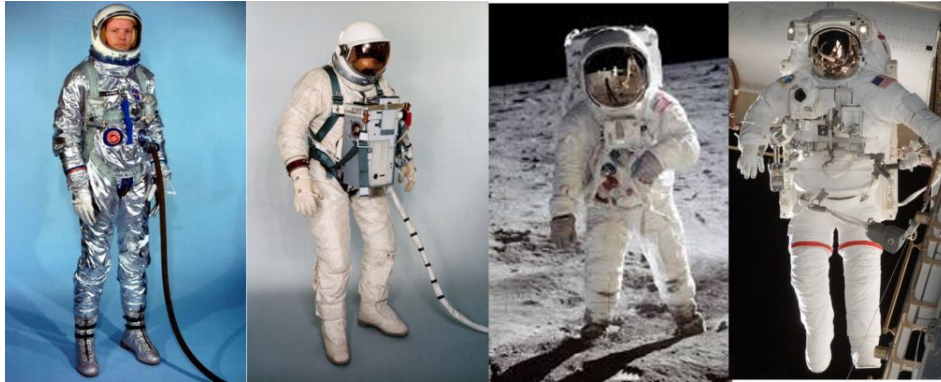
**Figure 1.1:** First known Spacesuit

*Image: Oberth [1972]*



**Figure 1.2:** First pressure suit

*Image: Mann [2011]*



**Figure 1.3:** NASA's Spacesuits *from left to right:* Mercury, Gemini, Apollo, Shuttle EMU

*Image: Google Images*

and closed during transition from normal atmospheric conditions to thinner atmospheres, and a flexible air-supply hose connected to a source of compressed air and a pump.

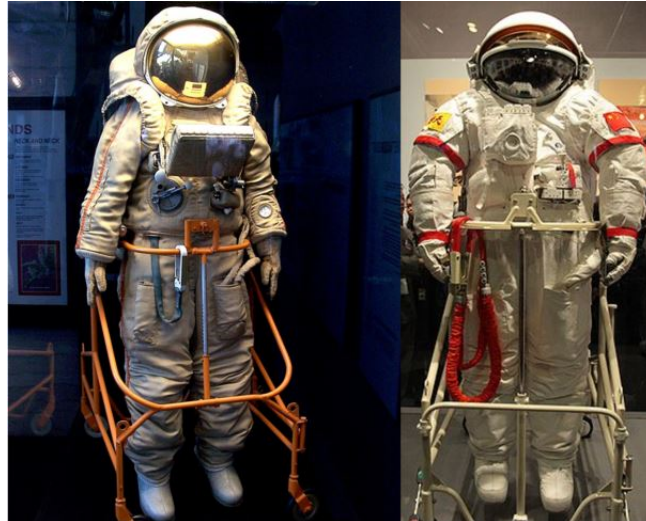
Henceforth, National Aeronautics and Space Administration (NASA)'s Mercury program was developed which flew the first astronauts into space. They were based on the pressure suits worn by U.S. Navy Pilots and could only be used inside the spacecraft. On March 18, 1965, history was created when Soviet cosmonaut Alexey Leonov spent 12 minutes outside the Voskhod 2 spacecraft. The same year, NASA's Gemini program took their first spacewalks using more advanced suits than Mercury suits but they connected to their spacecraft using umbilical for life support systems. Spacesuits designed for the Apollo program had the first LSS backpack. This allowed the astronauts to explore away from the lunar lander. See Fig 1.3

Modern spacesuits are more sophisticated such as the semi rigid EMU and the Russian Orlan which was used since the late 1970s for missions to Mir and International Space Station (ISS). Chinese space missions make use of the Feitian spacesuit, which is modelled after the Russian Orlan suit as seen in Fig 1.4. Taikonaut Zhai Zhigang wore one on the first Chinese extravehicular activity in 2008 during the Shenzhou 7 mission.

## 1.2 Parts of a Spacesuit

The Spacesuit consists of several parts. Due to broad range of components in a Spacesuit, only the parts pertaining to the thesis discussion, namely the Hard Upper Torso (HUT) and Portable/Personal Life Support System (PLSS) will be discussed in detail.

The rear entry spacesuit consists of a rigid metal body and removable soft shells for arms and legs. At the rear of the spacesuit body (torso) there is a rectangular opening for entry into the spacesuit. In addition, the body houses control consoles, the helmet with visor, the umbilicals and other auxiliary hardware. The spacesuit's



**Figure 1.4:** The Russian Orlan and Chinese Feitian Spacesuits

*Image: Wikipedia*

independent life support system is located in the back part (backpack), the backpack also serves as a pressurised hatch cover.

The HUT is the primary component of several Spacesuits such as Roscosmos' Orlan and NASA's EMU. The rigid enclosure, usually made of fibre glass, supports the upper body of the occupant and provides pressure containment for this part of the body. The HUT incorporates structural attachment points for the arms, Lower Torso Assembly (LTA), helmet, chest-mounted Display Control Module (DCM) and PLSS backpack. The HUT also includes an In-Suit Drink Bag, with a plastic tube extending into the helmet, to allow the astronaut to stay hydrated [Wikipedia, 2015]. On the back of the spacesuit is a backpack called the PLSS. This backpack provides a breathable atmosphere and removal of carbon dioxide; suit subsystems providing stable pressurization, temperature regulation, mobility, power, and communications; waste collection; particle and radiation protection; rovers and mobility aids; and tools that enable crew members to accomplish mission tasks. See Fig 1.5.

### 1.3 Mars Planetary EVA and Exploration

Since their early conceptions in the 1920s, spacesuits have become an integral part of humankind's exploration of space. During the past forty years, spacesuits have enabled astronauts to walk on the Moon, service satellites, and assemble the International Space Station (ISS). The current goals of the U.S. space program, announced in January of 2004, call for a return to the Moon and eventual human exploration of Mars [Aeronautics et al., 2004]. In this next era of planetary exploration, spacesuits will play an even more important role, enabling astronauts to interact with their surroundings and helping them to accomplish the scientific and engineering goals of the mission.

The success of astronauts in performing Extra-Vehicular Activity (EVA) is highly



**Figure 1.5:** HUT and PLSS developed by NASA

*Image: Wikipedia*

dependent on the performance of the spacesuit they are wearing. The Space Shuttle Extravehicular Mobility Unit (EMU) is a waist entry suit consisting of a hard upper torso (HUT) and soft fabric mobility joints. The EMU was designed specifically for zero gravity operations. With a new emphasis on planetary exploration, a new EVA spacesuit design is required [Graziosi *et al.*, 2005].

One of the most important tasks for preparation of a future manned mission to Mars is to create a space suit, which ensures efficient and safe operation of the astronaut on the planet's surface. The concept of space suit utilisation on the Martian surface will be determined mainly by the Mars mission scenario. Currently the preference is given to employment of robotics with the crew driving a Mars rover vehicle, whereby the suit will be used solely as an additional safety means. However, one cannot exclude the necessity of a durable self-contained stay of the man outside a pressurised compartment, to pick up, for instance, soil samples or do certain repair work in case of an emergency.

The requirements of the Martian suit and especially of the personal self-contained LSS will depend in many respects on the Martian environmental conditions, the space vehicle system concept and performance characteristics, the airlock and its interface design, the availability of expendable elements for the LSS, etc [Abramov *et al.*, 2005].

The primary functions of a Mars exploration EVA suit are to provide a habitable, anthropomorphic, pressurised environment for up to ten hours that allows crewmembers to perform autonomous and robotically-assisted extravehicular exploration. The Mars EVA suit should also facilitate science and research, construction,

and servicing operations on the exterior of the spacecraft and habitats in the hazardous conditions of the Mars environment [*Sipila and Mary, 2014*].

Spacesuits and EVA concepts of operations used on the ISS and during the Apollo Moon missions are insufficient to support Mars missions. Technical requirements for a Mars EVA suit include mitigation of the thermal fluctuations resulting from the Martian atmosphere, limitation of dust contamination, prevention of organic venting, and radiation protection [*Katuntsev et al., 2009*].

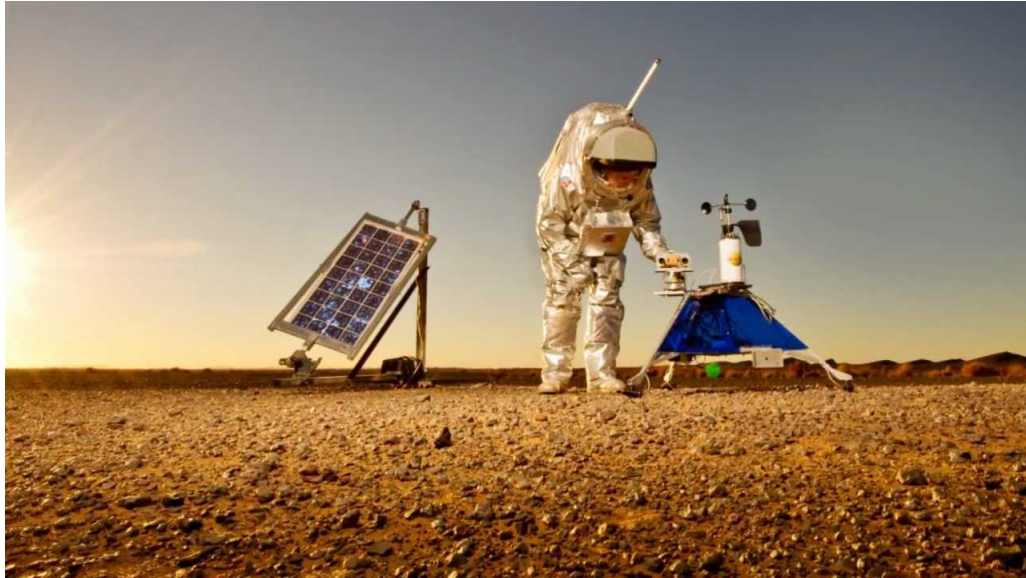
Mars will require a spacesuit that is extremely mobile, giving astronauts the ability to perform many different tasks with maximum efficiency. The EVA spacesuit will have to be lightweight to minimize crew member fatigue and launch weight. Future planetary missions will spend as long as 500 days on the surface requiring the EVA suit to be resistant to physical damage as well as handle severe temperature extremes. The suit will also have to be comfortable. Astronauts will perform daily EVA for long durations and therefore will not be able to tolerate discomfort, which over extended periods can lead to physical harm. Rationale for these requirements includes, but is not limited to, the presence of a  $0.38 g$  gravitational force on Mars, a need for EVA crewmember comfort and increased performance capability [*Masters, 2016*] and number of other performance requirements which will be discussed in Chapter 4.

## 1.4 Mars Analog Missions and Spacesuit Simulators

One of the current major goals in spaceflight exploration is to land on Mars. Till date, a number of landers, orbiters and rovers have been successfully sent to the Red Planet in order for us to understand the habitability of the planet but a crewed mission to Mars has been an ongoing operation for decades. As well as furthering human knowledge in the aforementioned fields, a crewed mission to Mars is the first step towards permanent colonization of planets other than Earth, believed by many to be a necessary step in ensuring the long-term survival of our species [*Matheny, 2007*].

A crewed mission to Mars, however, represents an expensive, time-consuming, and risky endeavour. A likely round-trip mission profile consists of outbound and return transit times of roughly 200 days each and a stay on the Martian surface for 500 days, for a total mission length of about 900 days [*Durante and Bruno, 2010*]. This timeframe greatly exceeds any space mission attempted thus far and also brings forth a number of challenges that spacefaring humans have faced before. In order to identify possible challenges faced by a potential future Martian crew, it is of utmost importance that terrestrial simulations or analog missions are conducted first.

Analog missions are field tests in locations that have physical similarities to extreme space environments. It prepares us for near-future exploration of asteroids, Mars, and the moon [*NASA, 2016*]. It is not enough developing planetary



**Figure 1.6:** MARS 2013 – Morocco Mars Analog Field Simulation by ÖWF

*Image: OeWF Media Team*

rovers, spacesuits and habitats if they cannot be tested on simulated planetary environments. Hence, analog missions play a significant role in problem solving for spaceflight research.

One of the pivotal research groups actively involved in Mars Analog Missions is the Austrian Space Forum - Österreichisches Weltraum Forum (ÖWF). The ÖWF is an organization based in Innsbruck, Austria which conducts human-robotic Mars analog missions as part of their PolAres Programme. The ÖWF has completed multiple Mars simulation missions, the recent ones being the MARS2013 mission which was a 4 week analog field test in the northern Saharan deserts of Morocco and the AMADEE-15 mission which was a 2 week Mars Simulation on the Kaunertal rock glacier in Austria. Both missions consisted of a field operations team conducting experiments under the instruction and supervision of a Mission Support Center in Innsbruck, Austria [Groemer *et al.*, 2014].

One of the foremost projects of the PolAres program is the “*Analog EVA Suit*” – the endeavour of designing, building and testing a Mars analog EVA suit, which allows the interactivity with robotic exploration systems whilst studying biological contamination vectors [Groemer, 2016].

Built by the ÖWF Aouda-X (a fully functional research grade prototype) is a novel spacesuit simulator that simulates the functions and feel of a spacesuit that could potentially be used by the astronauts on a planetary surface. This allows us to learn here on Earth the difficulty in operating and performing science on a distant planetary body. It enables the possibility of experiencing the physical restrictions and limitations of a mission to Mars without leaving the planet. Being one of the 4 research groups worldwide and the only team in Europe working on Mars analog spacesuits, this program has been established in order to help prepare for a human-robotic Mars surface expedition scenario.

## 1.5 Aouda.X Spacesuit Simulator - Current State of the Art

A spacesuit simulator, as the name suggests, is a suit worn by an Analog Astronaut (AA) which aims to realistically emulate the life support and biomonitoring capabilities of the planetary spacesuit as well as the working environment of the astronaut in the suit.

The Aouda.X-Ray (X) spacesuit simulator is designed to mimic several conditions of a real Mars spacesuit during a surface EVA, including weight, pressure, and limited sensory input. The system consists of a 48-kg hard-upper-torso suit, ambient air ventilation, a functional portable life-support system (PLSS) providing basic life support and health monitoring, a modified exoskeleton able to simulate various pressure regimes for all major joints, and capability for biomedical and engineering telemetry communications. The 48-kg mass was decided upon as an upper limit based on military research on the average mass load acceptable for long duration multi-hour operations for trained individuals [Groemer, 2016]. Aouda's subsystems will be briefly discussed in Chapter 3.

## 1.6 Statement of research problem

The main design complication of the Aouda.X is its overall weight. The system weighs 48kg of which nearly 57 % is comprised of the Suit's HUT, PLSS and On-board Data Handling (OBDH). In addition to this, the current configuration requires 3 hours of donning/doffing with the AA wearing the exoskeleton. This load of the suit is considered to be a paramount deterrent to the efficiency of the AA during simulated EVAs as they are subjected to a strenuous amount of physical activities in a challenging environment. In order to improve the ergonomics of the design, a relatively lighter HUT/PLSS design with efficient donning capabilities such as 'self-donning' must be developed. This will potentially relieve the AA of exhaustion and save time whilst donning/doffing. Based on a detailed literature research, an optimal solution to this problem is by implementing a Rear Entry design to the Aouda.X. Since this is the first utilization/realization of this type of design being implemented to Aouda.X, the objectives for development are aimed at performance improvement with respect to current operational suits and cost reduction.

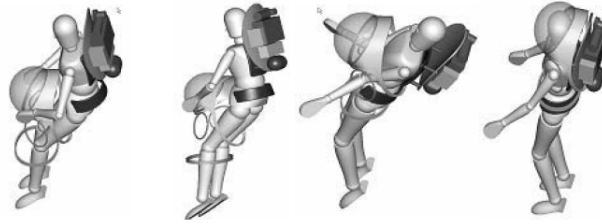
The Austrian Space Forum had recently decided to collaborate with University of North Dakota's Human Spaceflight Laboratory where a suit port concept has been underway. The target was to design a rear entry suit for Aouda.X to be compatible with this suit port leading to a potential Aouda - NDX cooperation. This will be detailed in Chapter 4.





Figure 1.7: Aouda.X Spacesuit and its major components

Image: OeWF Media Team



**Figure 1.8:** Donning technique for Rear Entry Suits

*Image: Dionne et al. [2006]*

## 1.7 Literature research

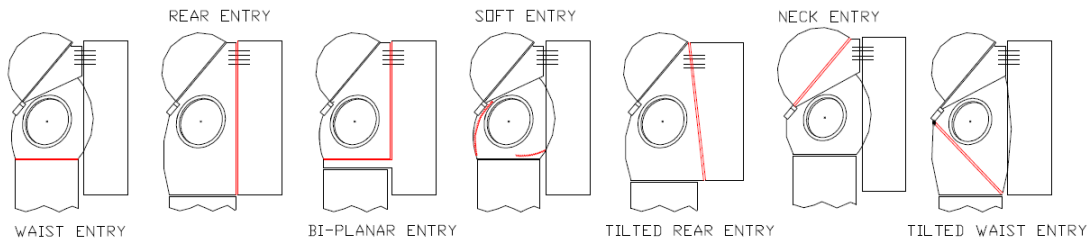
A detailed literature review of past and existing Spacesuit designs focused on performance parameters - particularly ease of donning and mass reduction, their entry types and planetary operational requirements was conducted to identify the ideal design configuration to implement on Aouda.X's HUT and PLSS.

The Martian surface is a substantially different place from any other that man has visited. It is instructive to compare it with previous and current manned space missions. Performance during EVA is dependent to a large degree upon the space suit worn by the astronaut. Comfort, and fit, along with consumables, determine maximum EVA duration. The ability to don the spacesuit quickly and safely is critical to maximizing overall productive EVA time. Self-donning capability is essential. Mobility of the space suit defines the work space envelope. Adequate mobility is also necessary to maximize productive EVA time. These suit design characteristics are affected by entry type. Space suit operations such as maintenance, and on-site reconfiguration are also affected by entry type. Spacesuit entry type is designed for a particular mission. The American EMU is designed for zero gravity for satellite servicing and deployment. It is designed with standard sizes and for minimal lower torso mobility which is not suitable for planetary exploration .

Requirements for mass, sizing, don/doff method, and mobility will be different for a planetary suit than for the EMU. The suit entry type should be designed concurrently with vehicle and habitat interfaces such as air locks, hatches, and manned rovers. With a new emphasis on planetary exploration, it is important to understand the effects of spacesuit entry types on EVA performance and spacesuit operations [Graziosi et al., 2004].

Various entry types have been designed and tested. Entry types used in previous spacesuits include waist entry, rear entry, tilted rear entry, bi-planar, and soft zipper opening. Other entry type possibilities include a tilted waist entry and neck entry. The various entry types are described below and are depicted in Figure 1.9.

From a comparative study conducted at ILC Dover [Graziosi et al., 2004] on the advantages and disadvantages of these entry types in accordance to planetary EVA performance requirements, it was decided that a rear entry design meets the performance requirements in Chapter 4 with some tradeoffs. It is also a good candidate to be used with the concept of a Suitport / Suitlock - an alternative technology to



**Figure 1.9:** Spacesuit entry types

*Image: Graziosi et al. [2004]*

an airlock, designed for use in hazardous environments and in human spaceflight, especially planetary surface exploration.

Once the type of entry system for the spacesuit was identified, a comprehensive study on the existing Rear Entry Suits was performed. The experience gained in the orbiting stations showed that the spacesuits of a semi-rigid type were the optimum suits to perform EVA. These suits (the ORLAN family) feature a HUT integrated with a helmet, a back entry hatch incorporating the LSS components and soft arms, LTA and legs [Abramov et al., 2005].

The following list provides the different Rear entry type spacesuits and their developers, considered during the course of the study:

1. Russian Orlan Suits (and predecessors from the Krechet Lunar EVA Suit Prototype)
2. I Suit (International Latex Corporation (ILC) Dover)
3. Zero Pre-Breathe (ZPS) Mark III (ILC Dover)
4. Chinese Feitian
5. EVA Suit 2000 / European Space Suit System (ESSS) (European Space Agency (ESA) and Russian Space Agency - Roscosmos (RKA))
6. NDX Series Suits (University of North Dakota Space suit Laboratory)
7. MX Series Suit (University of Maryland Space suit Laboratory)
8. Z Series Suits (NASA Johnson Space Center (JSC))
9. Prototype Exploration Suit (PXS) / NextGen Suit (Oceanering <sup>®</sup>)
10. Gandolfi Spacesuit (The Compagnie Maritime d'Expertises (COMEX))

The study combined with a detailed patent information study on rear entry suit analysis and development as well as test and operation data for EVA spacesuits, provided necessary information on Suit sizing, design configurations for the HUT and PLSS and locking mechanisms for the back entry hatch which could be further applied to redesign the current state of the art of the Aouda.X. Anthropometric

dimensional data will be considered from NASA-STD-3001 Space Flight Human-System Standard Volumes.

## 1.8 Research aims, scope and deliverables

The research work aims at developing an ergonomic rear entry design for the Aouda.X Space suit simulator, at the same time solving the issues addressed under the research problem. The entirety of the project consisted of a full product development cycle involving survey, design and analysis. The design, if applied to Aouda. X will be required to function at an analog mars environment at 1  $g$  and meet certain design requirements and performance envelopes (discussed in Chapter 4). Further material selection, manufacturing capabilities, and techniques, cost and services required were to be probed. Finite Element Analysis (FEA) was conducted to verify the loading and stresses apparent on the HUT after which the feasibility of the design was to be reviewed by stakeholders and trade off assessments performed. Unfortunately due to external factors , there was a lot of time lost during the major design phase of the project so further manufacturing methods and cost analysis could not be performed at the time of submission of the report.

The final product realization of the project was to provide a simulated 3D Computer Aided Design (CAD) model of the proposed Rear entry design conforming to the stakeholders' requirements of the HUT/PLSS of the Aouda.X. A down scaled, high fidelity, 3D printed HUT prototype was to be produced based on this model that meets and demonstrates functional requirements such as featuring a back hatch with a self-sealing/locking mechanism in addition to accommodating the PLSS components and interfaces .



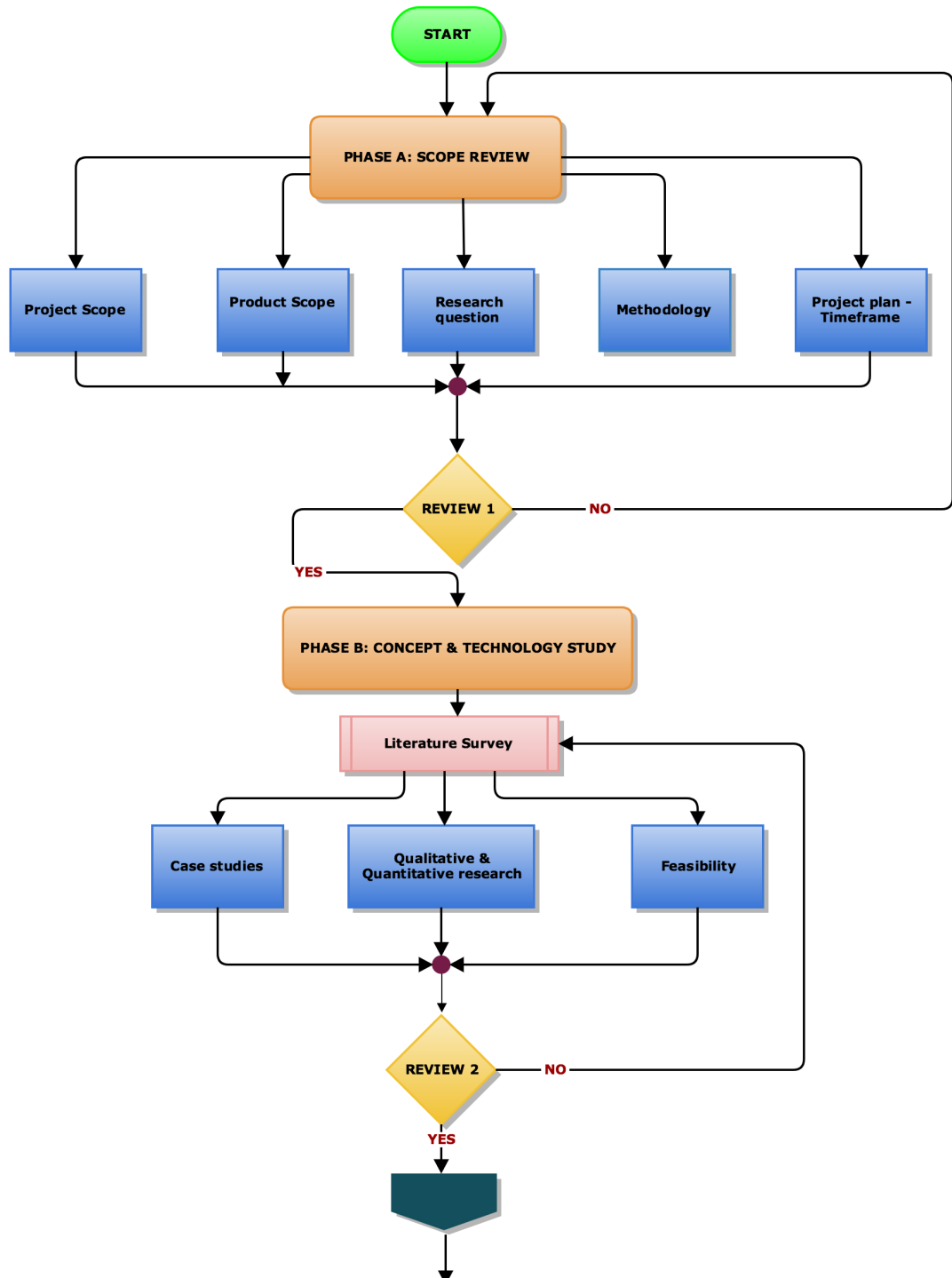
# Chapter 2

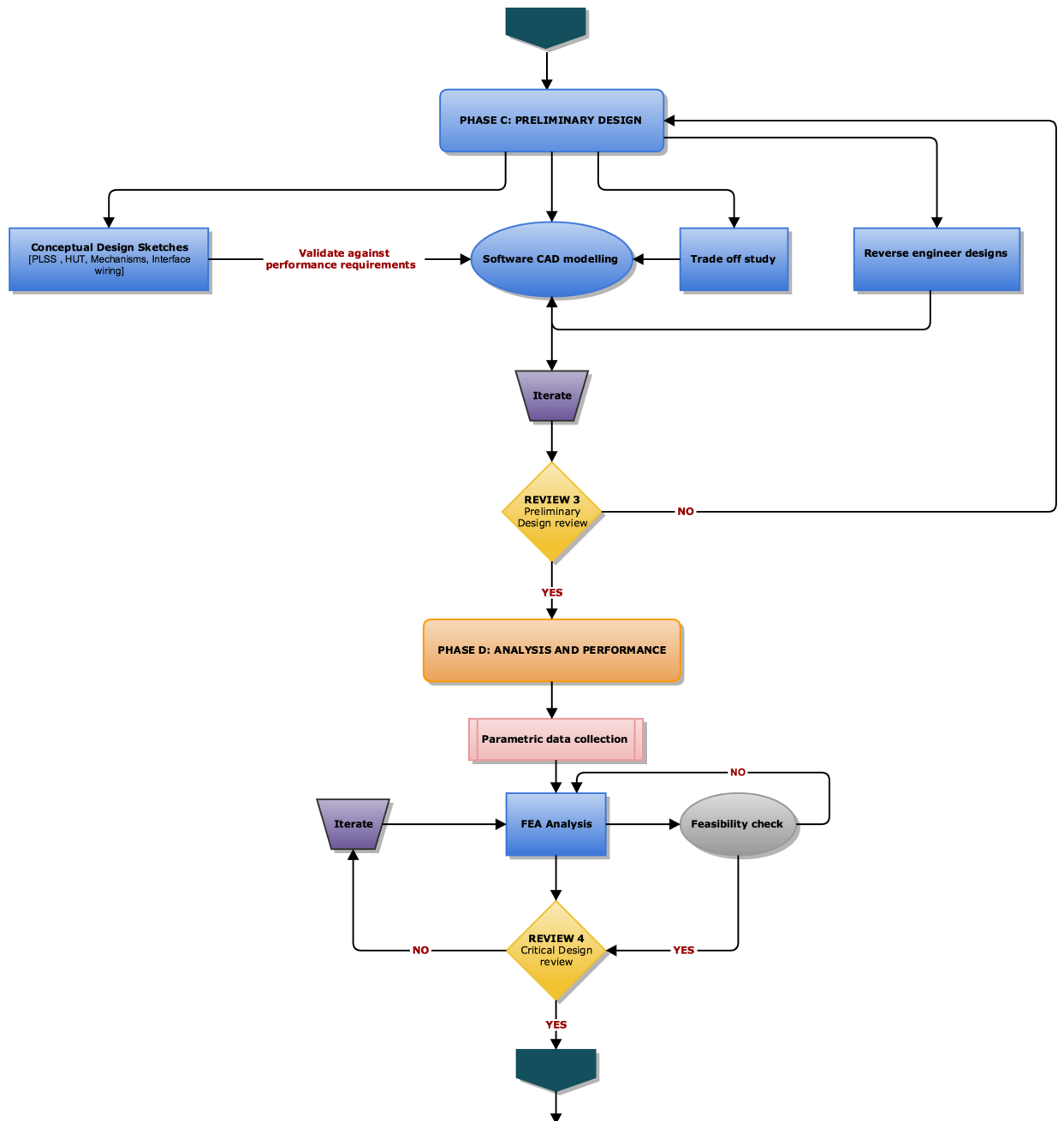
## Methodology

Considering the iterative nature of any planetary suit development, a detailed literature survey investigating past, present and proposed EMU/Planetary Rear Entry suit designs (primarily American and Russian space suit) as well as patent research was conducted. The current design parameters and specifications of the HUT/PLSS structure of Aouda.X was evaluated and indigenous capabilities and resources for implementing a new design were identified.

Stakeholder expectations and requirements in terms of performance metrics were further assessed by establishing a qualitative resource pool and performance benchmarks identified to evaluate the feasibility of the projected design. Upon approval of a selected design, it was modelled on a CAD (Computer aided design) software and then verified for structural loading .

The following flowchart 2.1 provides a detailed layout of the initial work-flow plan of the thesis from preliminary design to product deliverance. The final product served as a framework for further modifications as specified by the stakeholders.







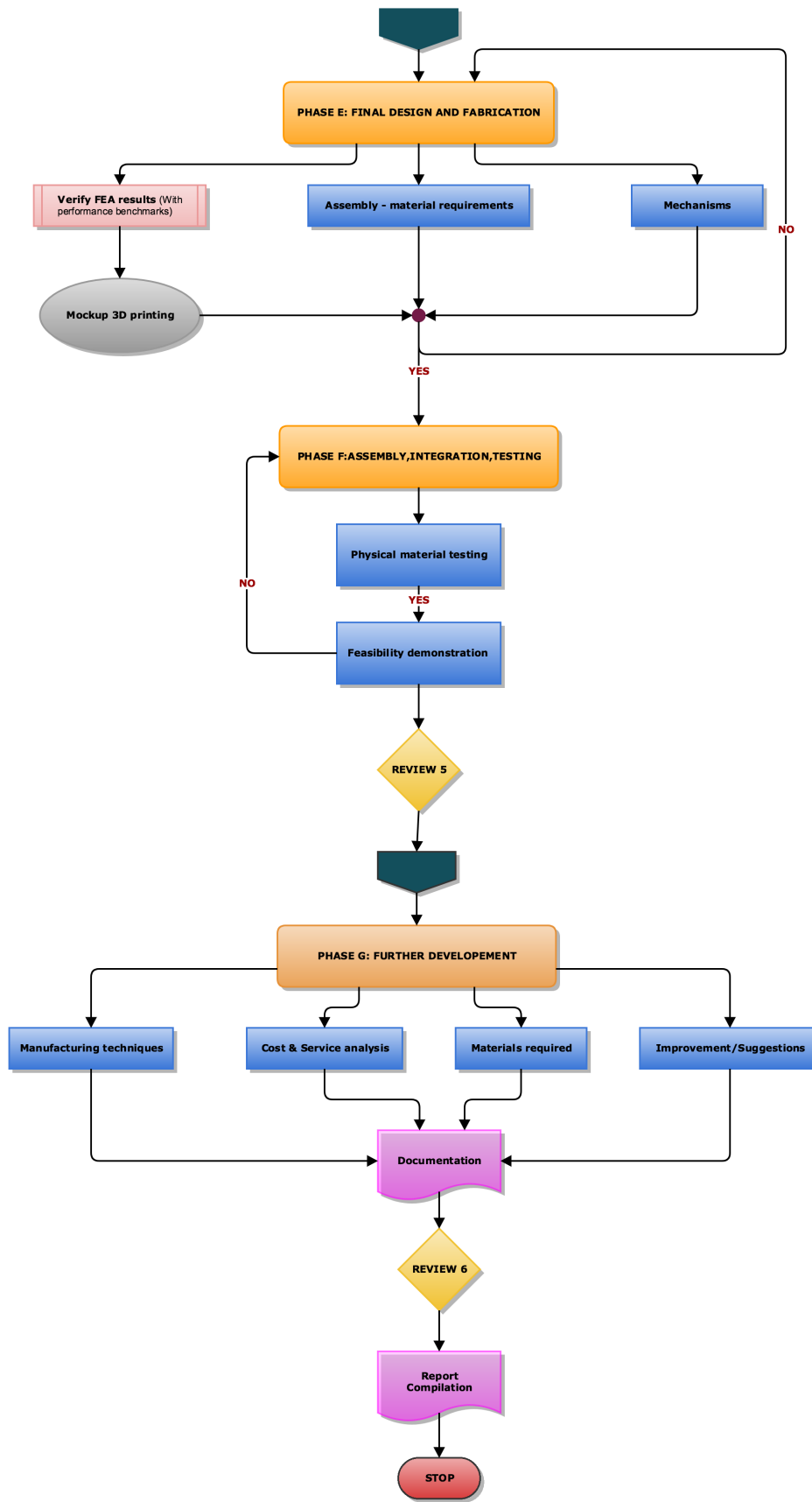


Figure 2.1: Project Methodology Workflow Diagram

# Chapter 3

## Aouda.X-System Configuration of HUT/PLSS

*'Aouda.X is both a spaceship simulator and a computer to wear.'*

- Aouda System Handbook [Groemer, 2016]

Aouda is based upon a Hard Upper Torso philosophy, which is a rigid structure, comprised of a hard shell where the Personal Life Support System (PLSS, the “Backpack”), the helmet, the gloves and trousers/boots are attached. This system weighs roughly 48 kg without additional experiments or soil samples, and complementary special equipment. This system mass was accepted as the upper limit, based upon experiences from military research of what the average mass load could be which is still enabling multi-hour operations for a trained human.

The suit is designed to study contamination vectors in planetary exploration analog environments and create limitations depending on the pressure regime chosen for a simulation. An advanced human-machine interface, a set of sensors and a purpose designed software act as a local virtual assistant to the crewman. It is designed to interact with other field components like the rover and instruments.

### 3.1 System Overview

- < 45kg including Hard-Upper-Torso, supplied with ambient air (in order to correctly replicate the weight to strength ratio present on Mars)
- Outer hull: Panox/Kevlar composite textile with aluminium coating
- An adjustable exoskeleton which can simulate various pressure regimes on Mars
- Biomedical and technical telemetry via broadband-WiFi (including of video, audio, temperature,  $CO_2/O_2$  sensors, Global Positioning System (GPS), air pressure/humidity, acceleration...), human waste management

- Human-Machine interface including speech recognition and acceleration sensors.

The mass overview of the major system components are given in table 3.1

## 3.2 Performance Envelope

- Operating time with one battery charged, measured from locking of helmet: 4-6 hrs (depends on individual usage and ambient temperature, including 2 hrs donning/ 1 hr doffing during field operations)
- Temperature limits: -110°C (tested) and +35°C (tbc)
- WiFi range > 1km (can be extended with directional W-LAN)

**Table 3.1:** Aouda.X System Mass overview

*Source: Groemer [2016]*

Spacesuit element	Mass [kg]
Hard Upper Torso incl. PLSS & OBDH (PLSS Box empty : 2.61 kg)	20
Pants, Gloves, Underwear	5
Boots	2
Exoskeleton	8
Helmet/Visor/ Head Up Display (HUD)	6
Accumulators (3 pieces)	5
Water (up to 2 l)	2
Total	48

Aouda.X is a system, which means, it is more than “just” the suit. This includes operational aspects, handling, transportation, safety aspects as well as crew and team issues.

## 3.3 HUT Structure

The approximately 4kg HUT holds most of the major Spacesuit parts together such as the helmet , the arm sleeves, the LTA, the PLSS and the Chest pack. See 1.7. It is made of glass fibre layers ( typically 5-7 layers of 163g Jamara 232513) with NEUKADUR LH 90 resin (curable laminate with high dimension accuracy and dimensional stability. The resin was chosen in the weight ratio of 100:25 to the hardener. [Groemer, 2016]. The HUT can be seen in figure 3.1

In order to allow the analog astronauts to consume water and eat in the suit, two camel-bag-type drinking bags are installed at the lower side parts of the HUT,



**Figure 3.1:** Empty HUT (configuration early 2014, here without aluminium reinforcements on the shoulders)

*Image: Aouda System Handbook*

A drinking valve is on both the right and left side of the neck-ring section. For food, a granola bar can be installed with a plastic holder at the neck ring. The Aouda has a detachable Chest-pack in the front of the HUT, which allows the AA to utilize a small set of standard equipment on any type of EVA.

### 3.4 PLSS Structure

The PLSS or the "backpack" comprising of the life support systems weighs approximately 2.7kg and hosts the multiple components, the majority of them falling under the following categories :

- OBDH
- Communications (COMM)
- Biomedical systems
- Support electronics (lights, Printed Circuit Boards (PCB) for HUT Sensors, cables and switches, etc.)

**NOTE:** The list of individual PLSS components, their mass budgets and images of the PLSS assembly are strictly confidential for intellectual property reasons and will not be shown in this report. The reader is welcome to contact the author for details about the PLSS.



# Chapter 4

## Performance and Test Requirements

In order to start with the design process of the rear entry suit, it is crucial to evaluate the requirements for how the suit should perform, the criteria of functionality and operability and how the design can be further tested to improve or verify these criteria [*Harris, 2001*] .

A project must start with a firm valid set of requirements. In advanced technology projects, most requirements change in the process of design and development. The rough ones we have now are sufficient to start evaluating competing designs. Analyzing surface access systems will help us better understand the requirements. New and desirable capabilities may emerge from future operations. The surface access system recommendations based on the current understanding of the requirements are subject to change. This chapter provides a detailed set of requirements for establishing a baseline for design and development [*Jones, 2007*].

Some of the major design drivers to be considered while designing any suit to evaluate:

- physical needs and characteristics of suit occupants
- environment the suit must contend with
- configuration and mechanical constraints of the mothercraft from which the suit must operate

It is first reasonable to identify what a Planetary Walking Suit should ideally look like . It should have the following specifications [*Webbon et al., 2007*] :

- Rear-entry
- Helmet angled and shaped for wide field view, including downward visibility
- Hard or soft torso, briefs and hip
- Waist bearing and flexion/extension joints

- Hip mobility joint system with 2 or more bearings and features for adduction/abduction
- Softgood arms and knees
- Walking boots with an ankle flexion/extension joint and ankle bearing
- Environmental protection garment that addresses dust, durability with UV radiation exposure, thermal protection in a low atmospheric pressure, durability against chemical corrosion and abrasion.

One of the reasons for emulating the Orlan design for Aouda was that the Russian designs were rugged, straightforward, easy to maintain, effective, practical and functional. The HUT was a paramount component to mount the heavy PLSS as it created rigid points on the HUT unlike a Soft Upper Torso (SUT). The concept of the back entry hatch developed by the Russian engineer Anatoly Stoklitsky had a very uncomplicated suit seal closure with minimal problems during donning.

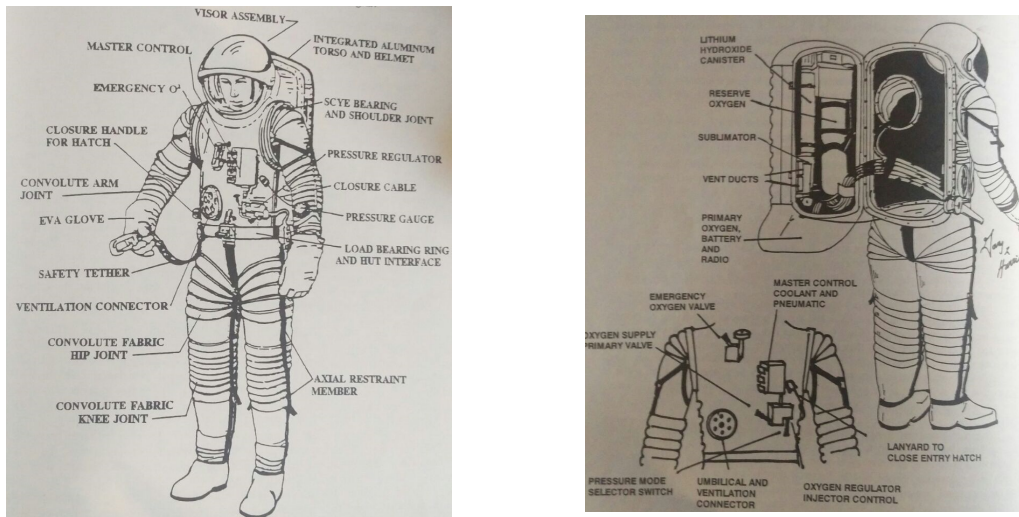
The early Krechet and Orlan rear entry suits had a rigid HUT frame which extended only till the waist. It consisted of an all aluminium helmet and torso which provided bearings for the shoulder -scye, lower trousers and back hatch (LSS). Air ventilation tubes were integrated into the suit shell.

## 4.1 HUT/PLSS requirements

The HUT forms the foundation of the spacesuit. It supports the LSS, display controls, opening for the entry closure, shoulder and waist mobility joints. It has a direct effect in the LSS configuration, don/doff capability, mass, volume, suit sizing, suit performance (i.e. visibility, mobility, comfort, etc) [Fertl *et al.*, 2006]. The PLSS has large mass and volume and is critical to the Center of Gravity (CG) and the outside envelope of the spacesuit [Graziosi *et al.*, 2004].

Unlike the earlier Orlan versions (such as SKV) which had a tall entry hatch, without a waist and hip joint and lower brief sections rigid, the requirements for a planetary suit are different as the Orlans were designed for use in the microgravity Space where donning, joint movement and bending at the waist are fairly easier than on, say a Martian surface with 1/3 gravity as on Earth. A majority of the components from the Orlan design (See Fig 4.1) can be reused with the addition of and removal of certain unwanted parts to suit a planetary environment.

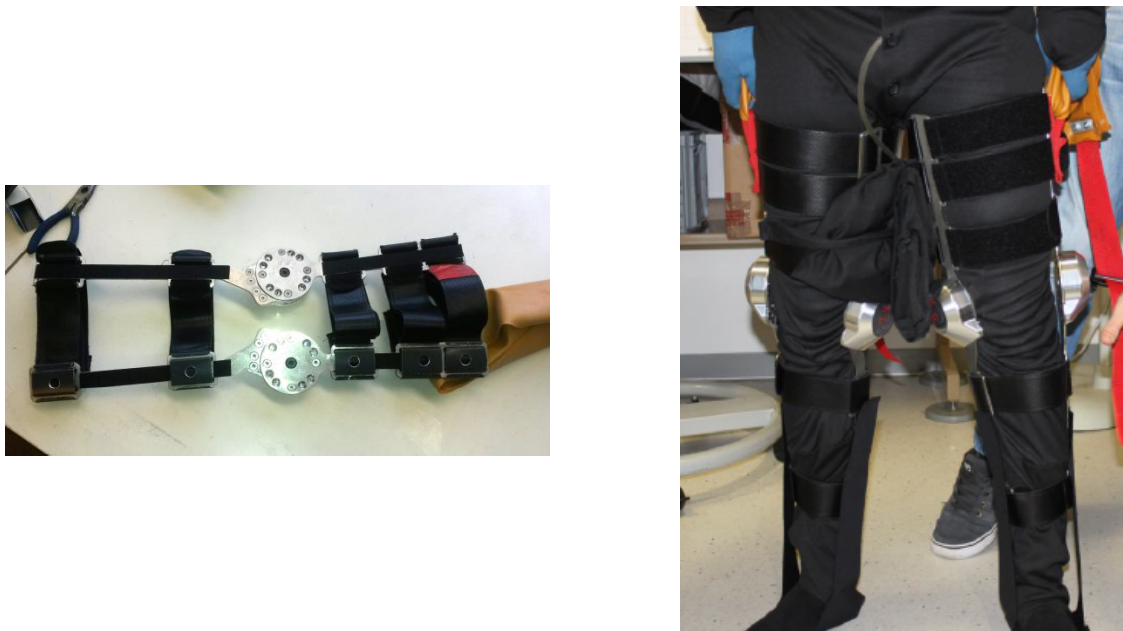
Another fundamental challenge to begin with in suit design is to control pressure. The problem arises when there is a need to provide the suit occupant with mobility while providing pressure at a controlled rate and volume allowing proper metabolism. In the case of Aouda.X, the suit by itself is not pressurised at the current stage of development. Rather the AA wears two sets of exoskeletons which simulate different pressure regimes as seen in Fig 4.2. They contain a set of torsion springs to counteract the flexing. By changing the angle of the cuff mounting, various pressure regimes can be simulated. The default setting is 0,6 bar (NASA ISS EMU), the



**Figure 4.1:** Line drawing of the front and back views of the Orlan D Space-suit

*Image: Harris [2001]*

systems also allows for 0,4 bar (Russian Orlan) and for test purpose 0,2 bar. One of the challenges and requirements for the design is that the rear entry should be compatible and large enough for an AA to climb into the suit whilst wearing the exoskeletons.



**Figure 4.2:** Exoskeletons for arms and legs

*Image: Aouda System Handbook*

Generally the "Nude Range" of the user is determined subjectively by measuring rotation and angular range of the joints. It is the measurement of the amount of flexibility that the human body can achieve if it is unimpeded by clothing, etc.



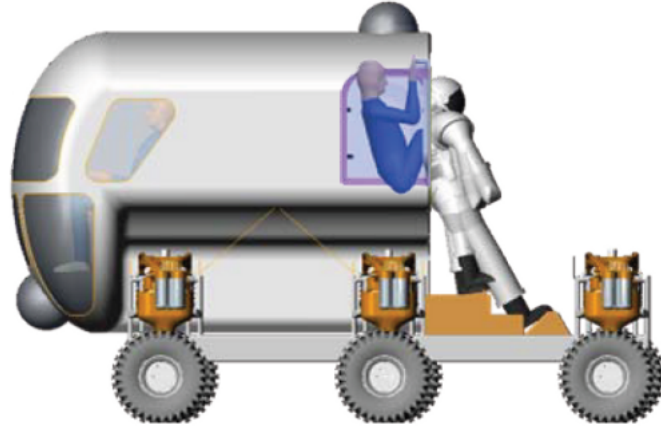
### 4.1.1 Design goals

While developing the rear entry HUT/PLSS design, there were numerous design goals that were kept in mind. There will always be a compromise between optimal fit for modularity. Although meeting all the goals would result in the ideal space-suit (which cannot be achieved without multiple design iterations and prototype developments), these goals can serve as a guideline for future Rear entry space suit developers:

1. Instructive to compare with previous and current manned space environments.
2. Rear entry opening aligned and angled forward from the vertical to enhance climbing and sliding down into the suit.
3. Convenient to don/doff in less than 10 minutes, remove helmet in an emergency, resupply suit consumables in less than 5 minutes and accommodate drinking bag [*de León et al.*, 2006].
4. Collecting biological samples/rock samples.
5. Following check list through Head Mounted Display (HMD).
6. Scye bearing should be omnidirectional with 360° rotation for shoulder.
7. HUT should be subjected to less leakage and load failure
8. Waist interface possibly angled upward of the horizontal (higher in the front than back) to improve forward bending and provide a good range of motion and mobility.
9. Possibility of replacing space suit arms and LTA.
10. Architecturally elegant, simple to engineer and configure
11. Inclusion of an adjustable shoulder pad / strap -suspension system for securing the astronaut , supporting and distributing weight.
12. Rescue requirements to make doffing of an incapacitated EVA crew member less difficult.
13. Necessary to provide the Planetary Space Suit (PSS) enclosure for sizing over the required / broad anthropometric range.
14. Latch mechanism situated near the anterior of waist of HUT making it easily accessible and visible for the user.
15. Tradeoff optimization studies in terms of performance, weight, safety, cost and reliability are essential.

## 4.2 Suitport compatibility

### 4.2.1 Suitport concept



**Figure 4.3:** An astronaut entering a spacesuit through a suitport

*Image: Wikipedia*

Current space suit designs require substantial time devoted to donning and removing the multi-piece suit, with more time and energy consumed to evacuate the air lock so that the astronauts can begin their Extravehicular Activity (EVA). For planetary surfaces, such as Mars, the airlock itself is a major source of contamination in the form of dust, which is abrasive compared to dust on Earth. The astronauts can egress with Martian EVA suits provided only through a landing module or airlock of a spacecraft as seen in Fig 4.3. The goal of the Suitport system is to address these issues and streamline EVAs.

### 4.2.2 NDX Suitport

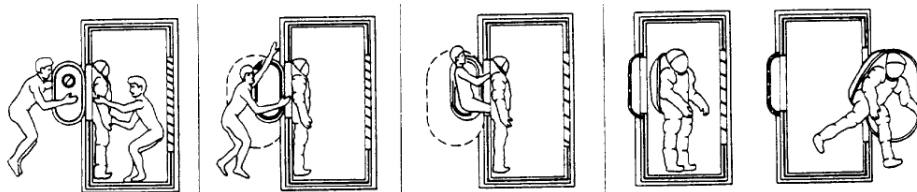
The Suitport is a two-part system with one half incorporated into the NDX-2, University of North Dakota (UND)'s rear entry space suit, and the other half attached to either the rover or the habitat (see Fig 4.4). Unlike current spacesuits, with the Suitport the spacesuit connects to the outside of the habitat, reducing transfer of dust. To enter the suit, the prospective astronaut opens the hatch on the interior of the habitat, then opens the hatch on the back of the space suit and climbs into the space suit. Once inside the astronaut operates a few mechanisms to close and seal the suit and rover/habitat connection.

The Suitport connection hardware on the NDX-2 encloses the space suit Portable Life Support System (PLSS) much like on current spacesuits. With this concept an astronaut is able to don their space suit and conduct an EVA without assistance from other crewmembers, something that is not possible with current space suit designs. Additionally, since the space suit stays outside the rover/habitat and since



**Figure 4.4:** *Left:* Suitport assembly that connects to the NDX-2 and Rover mount and Suitport dock. *Right:* Dome section of the space suit portion of the Suitport showing a mock up of the PLSS fitting.

*Image: deLeon [2016]*



**Figure 4.5:** EVA Access procedures using the Suitport, adapted from NASA TM-86856.

*Image: Cohen [1995]*

the astronaut doesn't have to re-enter the rover/habitat through an airlock the chances of contaminations from planetary dust is minimized [deLeon, 2016].

The development of the rear entry design should entail the fulfillment of the following tasks for Aouda [Abramov et al., 2002]:

- perform airlock procedures unassisted
- space vehicle ingress/egress
- martian rover ingress/egress
- control of rover driving

### 4.3 Test requirements

As evidenced in previous test methods of Spacesuits, resources for testing the design are to be implemented. Generally an accompanying *Test Stand* is utilized in conjunction with rear entry suits. These stands are built for the helmet, scye bearings, waist joints, hip bearings and body seal closures. They can be used to simulate don/doff studies [Harris, 2001]. A nominal baseline for comparison of the results can be used such as Shuttle EMU suit. Some good performance indicators that could be potentially used to test and evaluate the design are enlisted below [Harris, 2001]:

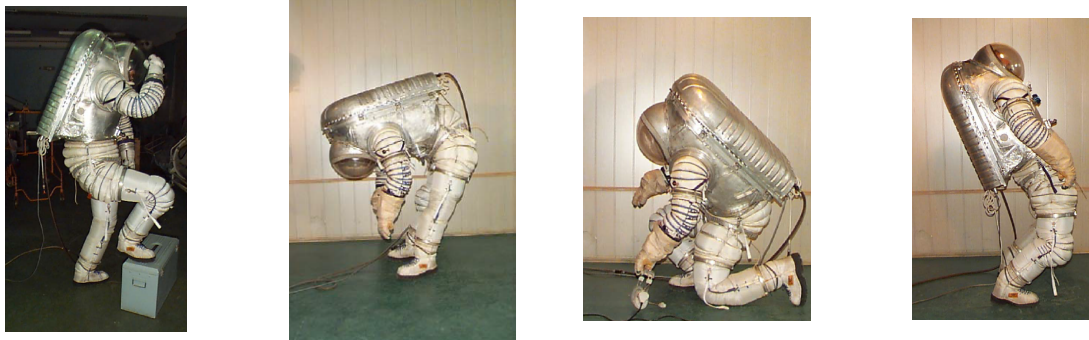
### 4.3.1 Task analysis

- Define rudimentary visibility and motion values imposed on the suit for the user to perform a series of tasks such as defining motion values (ranges) for:
  1. operating the body closure hatch handle
  2. closing/opening the helmet visor
  3. reaching the life support controls
  4. donning/doffing the suit and related functions
  5. ingress/egress of projected airlock and movement inside the airlock structure
  6. translatory movement in a narrow volume such as a tunnel
- Theoretical determination of Torso Ergonomic Sizing:
  1. ascertain basic HUT geometry
  2. angle placement of hip/waist bearings
  3. CAD wireframe models of HUT and bearings positioned around 3D human like computer models that encompass the sizing range
  4. theoretical analysis confirmed by building a mock up/ test jig
  5. fabricate high fidelity demonstrator model

### 4.3.2 Performance metrics

When performing planetary exploration tasks, the suited crewmember must walk on uneven terrain. The PSS design must allow the crewmember to stand up after falling and take intermediate positions (on all fours, kneeling, etc.), necessary to take the vertical position. The PSS enclosure must also allow the suited crewmember to take different static postures without excessive effort. Moreover, the subject may need to take these positions to complete a set of activities and exploratory tasks. This suggests a list of static postures (See Fig 4.6 and Fig 4.7) at which the PSS joints should be in an equilibrium state (i.e. position maintained with little or no effort) [Abramov *et al.*, 2001, 2005]:

- Standing up
- Walking on horizontal and inclined surfaces
- Bending forward
- Sitting
- Identification of angular movement ranges for suit mock-up elements (by photographing)
- On knee(s) and picking up things on the floor
- Ladder step climbing
- Leaning back
- On all fours



**Figure 4.6:** Climbing test, kneeling, bending forward and backward test

*Image: Abramov et al. [2005]*



**Figure 4.7:** Walking on inclined surface and standing posture

*Image: Abramov et al. [2005]*

**Table 4.1:** Summary of Requirements

Performance metrics	System Requirements	Measurables (quantitative)
<b>Mass</b>	Less than current configuration (27 kg for HUT and PLSS)	Mass breakdown of HUT and PLSS components, wiring, OBDH etc, Centre of mass
<b>Volume</b>	Volume of HUT and PLSS	Dimensional envelope; CAD model
<b>Comfort</b>	Comfort enhancing components; padding inside HUT; support harness; drinking bag etc	Dimensional envelope; Location in CAD model
<b>Entry method (Don/Doff)</b>	Self donning ; latch door unaided ; Ease of alignment in sealing the entry closure; Emergency extrication capability (active/passive)	Hatch dimensions ; anthropometric dimensions; Suitport dimensions
<b>Vehicle interface (Suitport)</b>	Border conditions or constraints required in case of attaching suit to a rover/ habitat	Suitport/ airlock dimensions; angle of entry
<b>Mobility</b>	Suit- body interaction; Ingress/Egress capability	Performance envelope – Volume covered ; Range of motion required Dimensional envelope of major HUT sizing
<b>Sizing</b>	Range of crew sizes	mounting locations of arm sleeves; lower torso; CAD model
<b>LSS interface</b>	Compatibility with current subsystems; Compatibility with NDX suitlock	PLSS components and location of components; umbilical connections etc; any interfaces for wiring; CAD model
<b>Structural integrity</b>	Fracture control; loading from bearings; structural loading	FEA loading conditions; stress,deflection ; any results available from previous analysis
<b>Environment</b>	Dust control, puncture resistant; thermal contraction /expansion; abrasion resistant	Operational temperature range
<b>Chronological life and maintenance interval</b>	Aging factors; cleaning; lubricating parts; removal/ replacement parts	Maintenance frequency
<b>Safety/Reliability</b>	Fire resistant/barrier	Nil
<b>Material</b>	Materials used in HUT /PLSS	Name of materials; Strength; Thickness; Weight
<b>Manufacture</b>	Currently used manufacturing techniques machinery; skills	Costs



# Chapter 5

## Design Considerations and Results

### 5.1 Challenges to System Design and Weight Issues

The most fundamental difference between a Mars EMU and those that precede it, is that the design of a Mars EMU must be driven by science and permanent habitability requirements, while all prior EMU designs have been driven by engineering requirements.

One of the most challenging issues affecting the design of the Mars EMU is system weight. The magnitude of this problem is apparent from Table 5.1, which shows EMU weight history from Apollo through Space Station Freedom projections. These data show a total system weight of  $100kg$  for the Apollo EMU,  $131 kg$  for the current Shuttle EMU, and anywhere from  $188$  to  $255kg$  for the projected Space Station EMU, depending on design. If any of these past, current or future systems were to be used on Mars, their equivalent weights on the Martian surface would range between  $38kg$  for the lightest design (Apollo) to  $97kg$  for the heaviest.

If one uses the apparent weight of the Apollo EMU on the Lunar surface as an upper limit, then  $17kg$  is a reasonable design target for carried equivalent mass on the Martian surface ( $100 kg * 1/6 G$ ). This means that previous, current and projected designs are too heavy by an apparent weight of at least  $21kg$  on Mars, or almost 50 percent. This means that a Mars EMU should have a target weight on Earth of  $44kg$ , or  $55kg$  less than the lightest system ever used in the manned space program. This will be an especially difficult problem, in light of the historical growth in weight that has characterized the EMU program (supposedly associated with increasing and necessary capability) [*Kuznetz and Gwynne, 1992*].

On this note, the structure of the Aouda.X that weighs the most - HUT and PLSS was reconfigured to be a rear entry suit with a target weight of  $44kg$  or less with even mass distribution for maintaining balance. It should be noted that there will always be a tradeoff between mass and mobility as these types of suits may lead to a slight increase in weight based on the size of the rear opening and strength of the closure.



**Table 5.1:** EMU Weight History

Source: Kuznetz and Gwynne [1992]

	Apollo	Shuttle	Space station
Suit	28	47	82-91
PLSS	63	73	97-155
Total weight (kg) [with boots, helmet, gloves, ancillary equip.)	100	131	188-255

## 5.2 HUT frame design considerations

The length of the rear entry opening and hatch height take up much vertical room. A shorter and wider opening results in minimal bending of waist whereas a longer opening requires more twisting of the hips. Ease of donning/doffing is primarily related to the size of the hatch opening and resistance from the LTA.

Raising the HUT structure (along with the back hatch door) increases the operational performance as it allows easier donning and doffing of the suit. This type of modification was evidenced in the Orlan M suit as this resulted in no additional effort by the crewmember to bend his head down when donning the suit, as this had been an area of complaint by some cosmonauts [Severin *et al.*, 1995]. Other advantages of raising the HUT are :

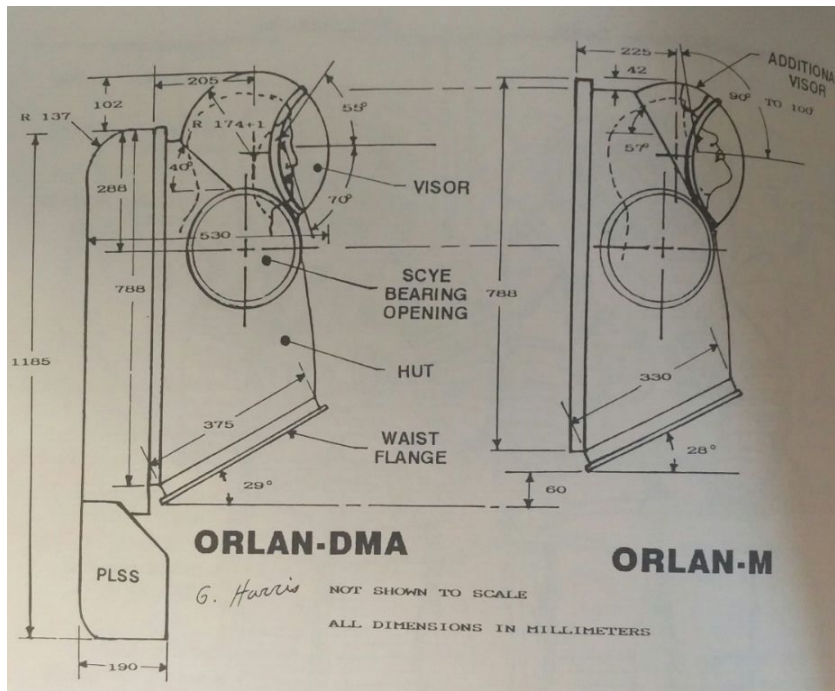
- an incapacitated crewmember can be more easily removed from the suit
- a corresponding rearrangement of components in the LSS allows an increase in internal volume in the HUT which increased comfort and allowed the HUT to accommodate updated components
- the modification of the HUT to optimize an integrated hemispherical helmet arrangement, permitting upward visibility to be augmented by an additional visor in the top of the helmet
- the Russian Orlan suits have a successful performance history

Accordingly, with the structure of the back hatch and its LSS up out of the way, the crew member can bend his head back enough to see through the upper visor as seen in Fig 5.1.

### 5.2.1 Contemporary design considerations

#### Orlan DMA:

Orlan DMA shown in this Fig 5.1 was designed to crew members of  $1.6m - 1.87m$  height and  $965 - 1105mm$  chest circumference. The design was a one size fits all HUT with a hatch opening  $393.7mm$  wide and  $787.4mm$  tall [Graziosi *et al.*, 2005]. The



**Figure 5.1:** General dimensions and comparison of Orlan-DMA and Orlan-M HUT

*Image: Harris [2001]*

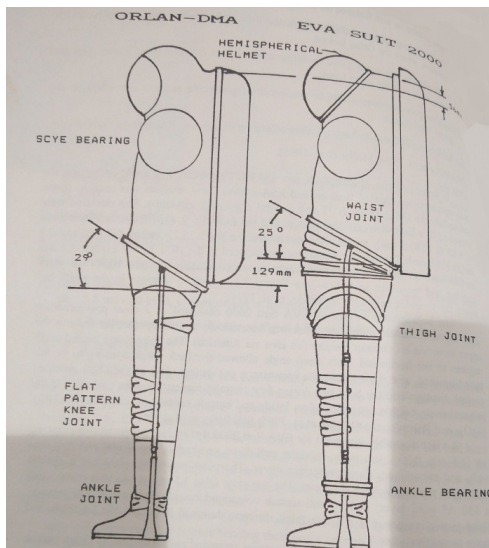
PLSS assembly was hinged at the left side of the HUT and held in place by dual diameter slide bar latches at the top, bottom and four places at the right side. The hatch assembly in this design was sealed by redundant seals [Harris, 2001].

### EVA/Russian 2000:

Meanwhile, the EVA/Russian 2000 (Fig 5.2) suit had an ergonomic suit sizing for Europeans and Russians of the height range  $1675\text{mm} - 1875\text{mm}$  and chest circumference of  $920\text{mm} - 1080\text{mm}$ . This design introduced the increase of helmet angle ( $55^\circ$  to the horizontal) and improved visibility. Another notable change seen in this design was the relocation of the rear door closure handles on the EVA Suit 2000 from the lower right side of the Orlan to the front of the helmet ring. This aided in rescue requirements to make the doffing of an incapacitated EVA crew member less difficult [Harris, 2001].

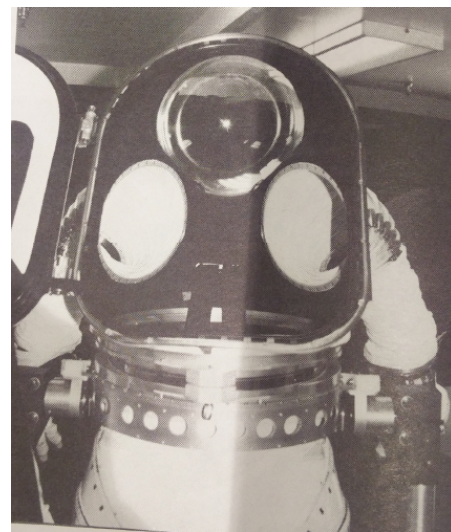
### ZPS Mark suits :

The plane of the rear entry opening was aligned at an angle of  $9.5^\circ$  forward of the vertical to enhance climbing into the suit (Fig 5.3). The entry hatch was designed to hinge like a refrigerator door. The opening was  $520.7\text{mm}$  wide and  $609.6\text{mm}$  tall [Graziosi et al., 2005]. The waist interface angle was tilted at  $15^\circ$  upward of the horizontal to improve forward bending [Harris, 2001].



**Figure 5.2:** Comparison between architecture of EVA 2000 suit and Orlan DMA (left) and Initial Zvezda prototype for arms and rear entry testing (right)

*Image: Harris [2001] and Skoog and Abramov [2007]*



**Figure 5.3:** ZPS Mark III hard torso shell (left) and Rear entry closure (right)

*Image: Harris [2001]*

### NDX-2:

The rear entry hatch of the NDX- 2 (Fig 5.4) is  $508\text{mm}$  wide and  $635\text{mm}$  tall and tilted at  $15^\circ$  from the vertical so that the subject can easily slide into the suit [de León et al., 2006].

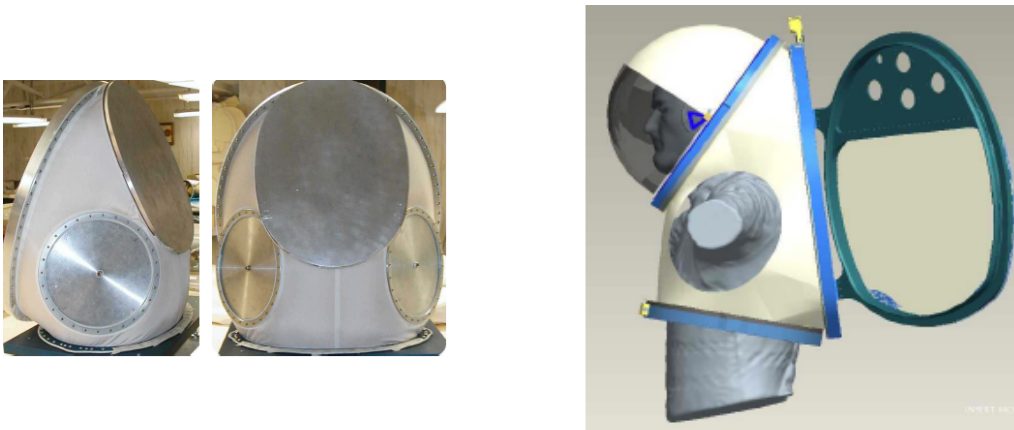


**Figure 5.4:** NDX-2 HUT (*left*) and Helmet, Rear and Waist rings (*right*)

*Image: de León et al. [2006]*

### I-Suit:

The I- Suit (Fig 5.5) is a tilted rear entry suit with a hatch opening of  $508\text{mm}$  width and  $584.2\text{mm}$  height. There were less restrictions on the inter scye dimensions but the torso length was long enough to accommodate the vertical length. This rear entry design had more mass due to size of opening and strength of closure [Graziosi et al., 2005].



**Figure 5.5:** I-Suit HUT (*left*) and Rear entry closure design (*right*)

*Image: Graziosi et al. [2005]*

### Z-2 Suit:

One of the most interesting design considerations addressed in this design is shoulder mobility and injury prevention. The scye (aka shoulder) bearing should be



**Figure 5.6:** Movement of shoulder

*Image: Graziosi et al. [2005]*

positioned inboard of the acromion (i.e. the bony process on the scapula that is attached to the collarbone) to better allow shoulder mobility and limit the potential for injury. When the scye bearing is inboard of the acromion, the scapula can move freely through a wider range of motion within the suit as the arm is lifted over the head before impinging on suit hardware, as shown in Fig 5.6.

A critical anthropometric dimension associated with this fit is the biacromial distance. The related suit dimension is called the *Q distance*, and is defined as the distance between the center points of the innermost planes of the scye openings. The Z-2 is designed with a nominal Q distance of 11in(280mm) with a sizing feature that produces a 10in(254mm) Q distance. These distances are smaller than the ISS EMU planar and pivoted HUT Q distances, respectively, making the Z-2 the first EVA pressure garment to be sized that small. The rear entry design contributes to enabling smaller Q distances because, unlike a mid-body entry design, the Q distance does not have to be compromised (widened) to allow donning and doffing. Generally, rear entry designs mitigate the shoulder mobility issues associated with HUT chest depth that cause limitations to movement of the scapula. The slanted geometry of the hatch interface provides increased volume in this area allowing the scapula to move without impinging on the hatch structure [Ross et al., 2014].

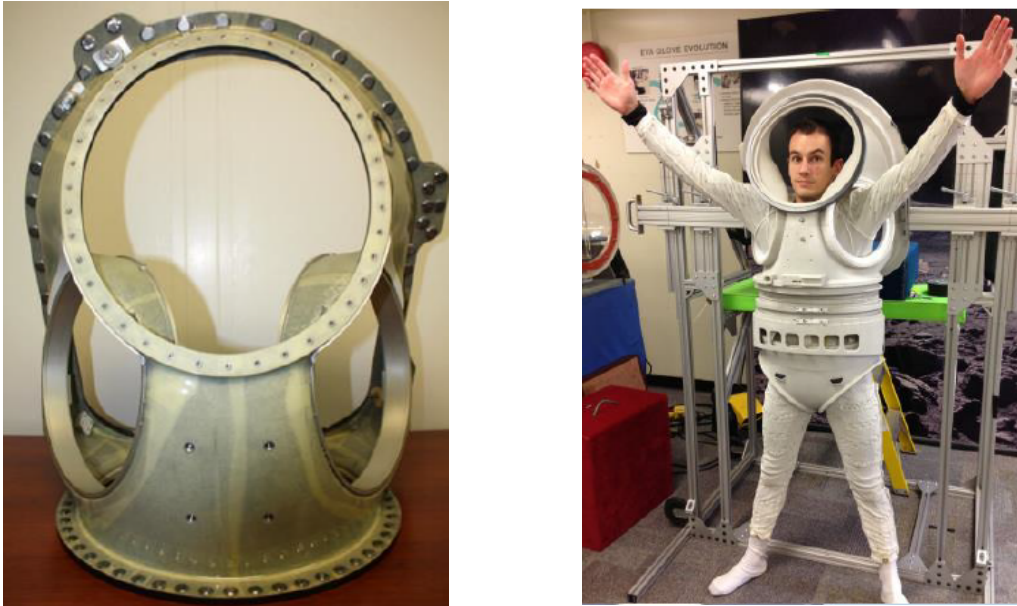
The modelling was made keeping this benefit in mind as the human-to-hatch interface was designed. The HUT architecture consists of a Mk-III style rear entry, elliptical neck ring interface flange, scye openings sized for a new 228.6mm inner diameter bearing, and a circular waist opening flanged to accept a 381mm inner diameter waist bearing. In order to provide improved sizing for subjects within a given HUT size, the Z-2 design includes two sets of scye insert rings that allow the scye bearing breadth to be moved in or out 12.7mm per side. This effectively makes two HUT sizes in one when comparing to the ISS EMU HUT sizing scheme. The

**Table 5.2:** Dimensions of EVA space suit rear entry hatches

*Source: Abramov et al. [2001]*

Dimension	Orlan-M	EVA-2000	AX-5	MK-III	PSS
Entry hatch height (mm)	788	724	700	584	600
Entry hatch width (mm)	390	454	432	457	400

interior of the HUT includes bonded Velcro that provides attachment for a drinking bag. There are two shoulder harness options, one with a self-retracting webbing reel for self- don/doff. The self-retracting webbing reel utilizes a push/pull cable assembly that is actuated to the lock position when the hatch is closed [Graziosi et al., 2016].

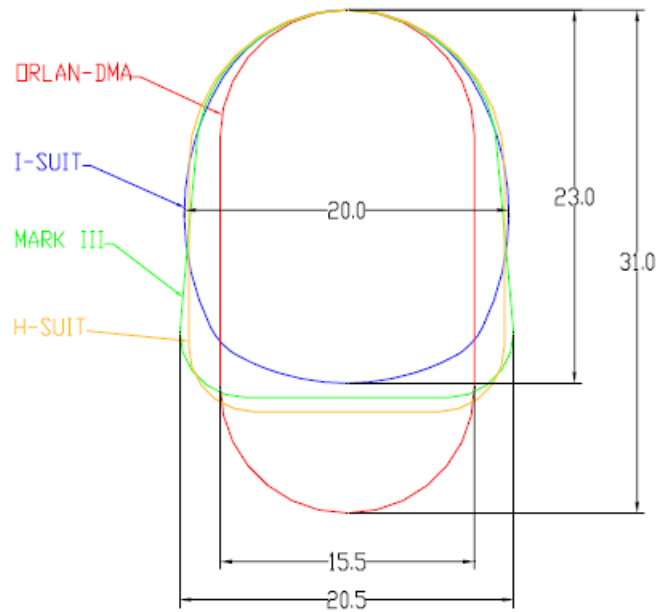


**Figure 5.7:** Z-2 HUT Shell (*left*) and Z-2 Suit 3-D printed prototype design (*right*)

*Image: Ross et al. [2014] and Graziosi et al. [2016]*

Selection of the optimal minimal rear entry hatch dimensions with easy donning/doffing taken into account will allow the designers to decrease the space suit mass in comparison with existing designs. The space suit HUT mass also depends on selection of materials and technology, but while the HUT enclosure can be made both from metal and fabric, the HUT frame and flanges can be made only from metal. Some of the rear entry dimensions used to make a comparative study as well as choose an optimal design selection for Aouda.X are shown in Table 5.2 and Fig 5.8.

Keeping in mind the major criteria fixed for designing the rear entry hatch for Aouda.X which is to be compatible with the NDX suitport hatch, PLSS attached to the back of hatch, the hatch opening from the bottom due to the constraint



**Figure 5.8:** Comparison of Rear Entry Openings in Inches

*Image: Graziosi et al. [2005]*

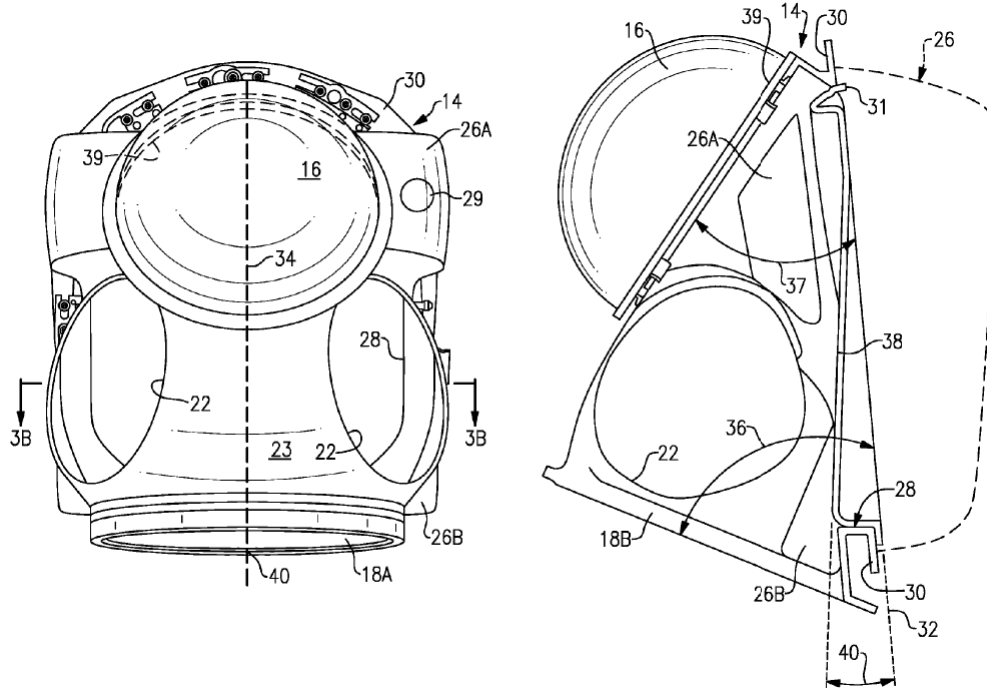
of the suspension straps and fixed helmet ring dimensions, a suitable HUT design was selected based on the patent study made on *"Pressure Assist Hatch Closure"* design as seen in Fig 5.12 as well as *"Hard Upper Torso For Rear Entry Suit"* for dimensional measurements. This hatch works similar to aircraft doors. The following section describes the working and structure of the selected design and the important design parameters considered while estimating measurements for the CAD model.

## 5.2.2 HUT Design features and mechanism

### Estimation of HUT proportions:

It is arguably optimal to take an existing design and improve upon it while retaining critical systems that are proven. Preliminary design measurements were taken from the claims outlined by the author in the patent *Hard Upper Torso For Rear Entry Suit* [Thomas, 2011]. Describing the parts of the suit will be beyond the scope of this report and the reader can turn to this patent for the description of the labeled components. This section describes only those key features that had been adopted while designing the HUT for Aouda.X. Refer Fig 5.9.

- The suit includes a hard upper torso having an entry opening and shoulder apertures.
- The hard upper torso extends along a subject axis configured to coincide with the axis of a subject having donned the suit.



**Figure 5.9:** Front and Side cross sectional view of proposed Rear entry HUT

*Image: Thomas [2011]*

- The entry opening lies in a plane at an angle  $7^\circ \pm 5^\circ$  relative to the subject axis.
- The suit includes a hard upper torso with a waist bearing that attaches to the bottom of the HUT.
- The HUT includes a shell that supports a visor and portions of a primary life support system which are located inside HUT protrusions and outside the entry opening through which a subject dons the suit.
- The protrusions may be volumes inside the HUT or protective covers for volumes outside the pressure volume. The protrusion volumes can be shaped to utilize the maximum HUT width while avoiding impingement on arm movement.
- Placement of primary life support system elements in the HUT protrusions reduces the PLSS mass and volume behind the subject during EVA. This redistribution moves the PLSS mass closer to the subject's center of gravity for improved mass control during subject movement while providing a more front-to-back compact suit system envelope. The protrusions may also provide a mounting area to which lights or other devices may be attached external to the HUT.
- The entry opening is lies in a plane to which the PLSS is mounted.



- The visor is secured to a visor opening in the HUT that lies in plane at an angle of  $40^\circ \pm 5^\circ$  relative to the plane on which the PLSS lies.
- The top of the entry opening has a wall in a direction that is approximately perpendicular to the subject axis, such that the top of the entry opening is about level with the inside of the visor.
- The positioning of the entry opening relative to the visor in this manner enables the subject easy entry into the suit while avoiding the need to reposition the HUT upward or downward significantly subsequent to donning the suit in order to locate the subject's head within the visor.
- The HUT shell may be of hybrid (two or more different fiber systems) composite construction. The shoulder apertures may be non-circular and lie in planes that are canted forward and inward (at the top) relative to one another, as best shown in Fig 5.9.
- Each shoulder aperture plane includes an axis intersecting the subject axis at an angle of  $29^\circ \pm 5^\circ$  relative to the entry opening.
- The shoulder aperture planes are at an angle of  $17^\circ \pm 5^\circ$  relative to the subject axis.

### **Preliminary skeleton design:**

Preliminary sketches were outlined taking into consideration the requirements and dimensional constraints mentioned in section 5.2.2. Further dimensional baselines were taken from [Lexen, 2016]. The author had provided reference dimensions of a mockup of a "Inside Hand Access Suit for surface EVA" constructed by him. See Fig 5.10. This low-resolution prototype approximates a generic rear-entry HUT design, although it is more similar to the Orlan than to latest ones in development. The focus was on modelling the interior space as defined by the relationship between scye, helmet ring, back plane, and waist ring, in order to explore and define the back recess (shoulder and elbowroom) needed for hand access. The author designed and optimized the mockup just for himself. This project excludes torso sizing or adjustments for range of 5th to 95th percentile users, and also excludes determining optimal scye spacing, scye placement and angles.

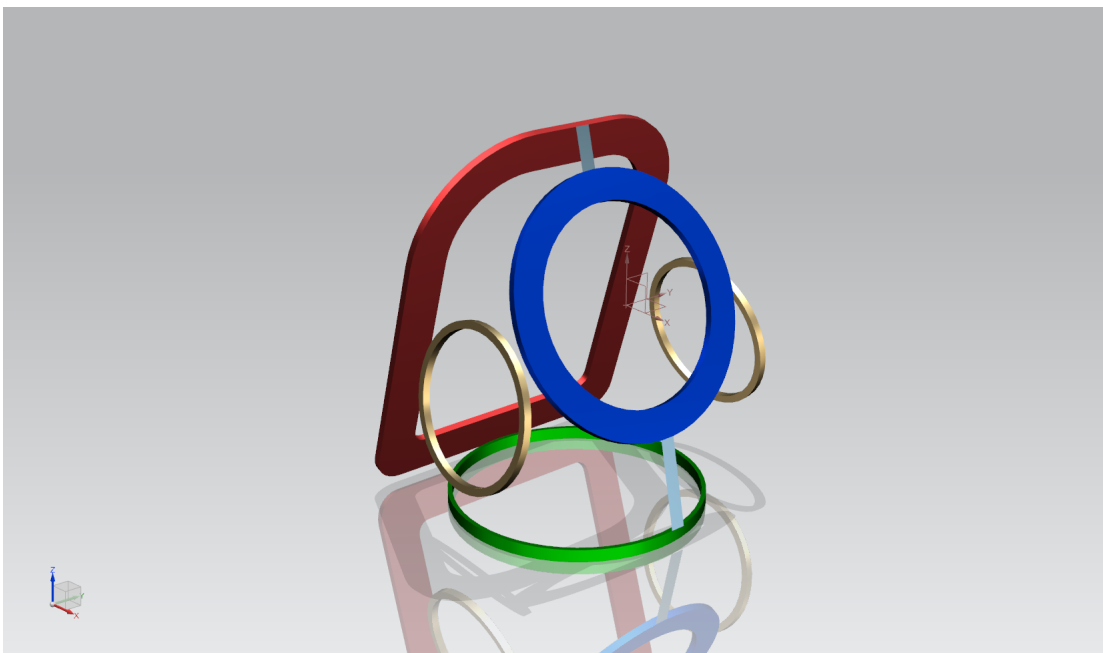
The dimensions were a composite from various current prototypes, including scaling from photos. The mockup was designed to custom-fit the author; for instance the scye placement is a compromise based on what seemed reasonable after much trial and error. These were of course, not any guide for general rear-entry design, but only a reference point. The model also had a rear hatch opening similar to that of the NDX-2 suit.

The outer skeletal frame of the HUT was designed in NX- CAD using baselines mentioned earlier. The design was modelled with the intention of prototyping a wooden mockup assuming a frame thickness of  $12.7mm$ .



**Figure 5.10:** Inside hand access mock up frame

*Image: Lexen [2016]*



**Figure 5.11:** Skeletal frame of designed HUT

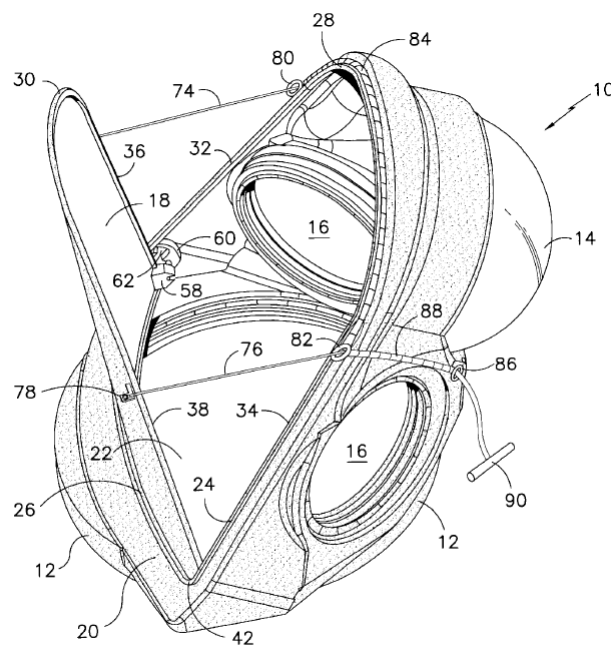
From the Fig 5.11 one can clearly identify the main components : Helmet ring (blue), Scye (yellow) , Waist ring (green) and outer rear entry hatch (red). The significant baseline dimensions of the HUT are briefed below:

- Helmet dome ring : Outer diameter =  $434mm$  ; Inner diameter =  $330mm$
- Helmet ring angled at  $25^\circ$  from the vertical
- Back hatch angled at  $18^\circ$  from the vertical
- Length and width of rear hatch is  $641.4mm$  and  $516.4mm$  respectively

- Waist ring : Outer diameter =  $434.4mm$ ; Inner diameter =  $419.1mm$  at a distance of about  $245mm$  from the lower tip of the helmet ring
- Scyes each tilted at  $10^\circ$  from the vertical, each of inner diameter  $244.28mm$ , and further apart from each other by  $527.05mm$

### System operation and sealing mechanism:

The summary excerpt of the invention and its working is adapted from the patent [Dean, 2001]. Describing the parts of the suit will be beyond the scope of this report and the reader can turn to this patent for the description of the labeled components. The design can be adapted to suit the specifications of Aouda.X with the exception of eliminating the need for pressurization as detailed in the following section. Since Aouda is not a pressurised suit yet, only the physical closing mechanism controlled by a webbing reel/ cable system will be adopted although the locking/sealing mechanism can be potentially used if and when the Aouda. X will be used as pressurised suit. This type of draw cable system was used for pulling the rear entry door hatch in Orlan DMA.



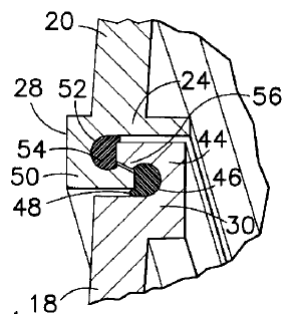
**Figure 5.12:** Rear entry hatch - right side perspective and outward tilted mode

Image: Dean [2001]

The closure system shown in Fig 5.12 comprises of a frame member provided within a HUT section of an astronaut spacesuit such that the closure system comprises a rear-entry type closure. The closure member is provided with an outwardly projecting peripheral flange portion and a seal member, while the frame member is provided with a complementary, mateable inwardly projecting peripheral flange

portion and a seal member which operates together to form the pressure assist closed type hatch. Pressurization of the space suit increases the sealing of the system and the closure cannot be opened without depressurization of the suit. The closure member and frame opening have substantially triangular or trapezoidal configurations whereby the closure member can be vertically moved and pivotally tilted with respect to the frame member so as to permit such a closure to be opened and closed with minimal interior space within the spacesuit. A cable control system, similar to the one used in the Orlan DMA suits, enables the astronaut to easily and readily open and close the closure member with respect to the suit framework.

The pressure-assist closed door or hatch closure comprises a trapezoidal or triangularly configured closure which is adapted to sealingly mate with a similarly configured access opening framework provided within the rear portion of the astronaut space suit, specifically, within the head or helmet and upper-torso region of the space suit. The wider base portions, having the larger lateral or transverse dimension, of the closure and access opening framework, are provided within the bottom or lower regions of the closure and framework components, while the narrower or apex portions, having the smaller lateral or transverse dimension, of the closure and access opening framework, are provided within the top or upper regions of the closure and framework components, with the narrower or apex portions of the closure and framework components being rounded and defined by means of a large radiused curve so as to match or complement the suit helmet curvature. Substantially identical tongue-and-groove (see Fig 5.13) elements, having suitable seal members extend continuously around the perimeter portions of the door or hatch closure and the space suit access opening framework, and the door or hatch closure is slightly larger in all dimensions than the space suit access opening framework so as to define a pressure-assist closed type hatch.



**Figure 5.13:** Locking mechanism consisting of a tongue - groove flange and trunnion and mounting brackets

*Image: Dean [2001]*

When the interior of the space suit is therefore pressurized, the tongue-and-groove elements and their associated seal members of the door or hatch, and the space suit access opening framework, will thus engage each other so that pressure loads upon the door or hatch closure are effectively and uniformly distributed to the suit access opening framework, without stress concentration points, whereby the

proper and desired pressurisedsealing of the space suit environment in a pressure-assist closed type manner is achieved.

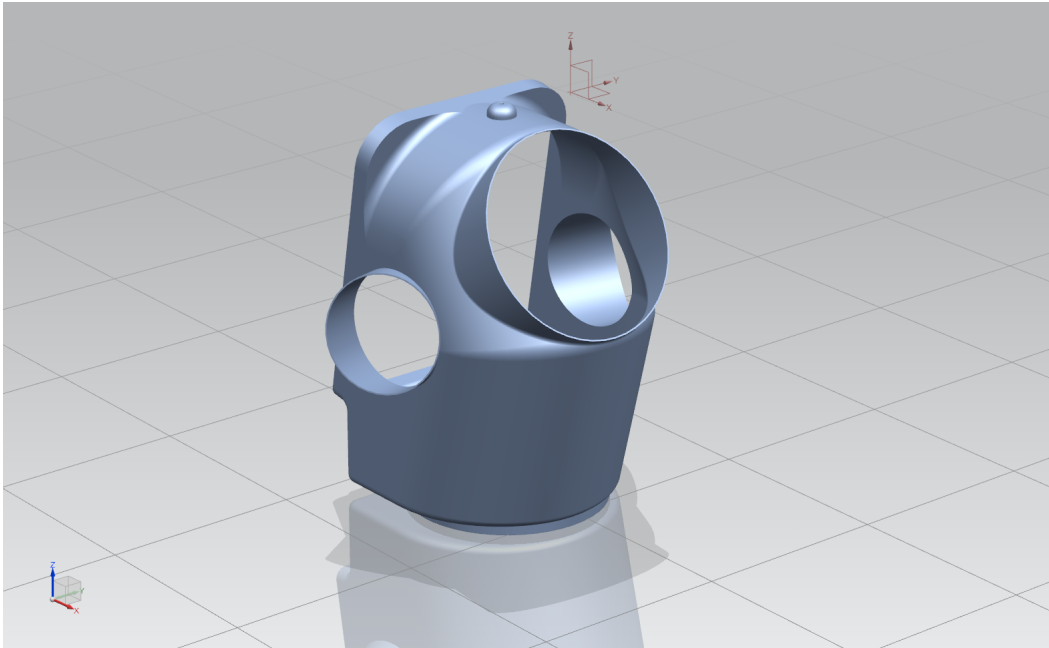
When it is desired to open the door or hatch closure, the interior pressure within the suit is reduced to a near-zero pressure level so that the door or hatch closure can be moved slightly inward, with a minimum amount of force, into the suit interior with respect to the access opening framework and thereby achieve disengagement of the sealingly mated tongue-and-groove elements and their associated seal members. The door or hatch closure is then slid vertically downwards a predetermined slight amount with respect to the access opening framework whereby the tapered sides of the door or hatch define a slight clearance with respect to the corresponding tapered sides of the space suit access opening framework. While a larger clearance is defined between upper end of the door or hatch closure and the upper end of the space suit access opening framework. The door or hatch can then be tilted with respect to the access opening framework such that the upper end of the door or hatch projects outwardly from the space suit access opening while the bottom end of the door or hatch remains inside the space suit and protrudes only slightly into the interior space of the suit. With the door or hatch closure disposed in this position, the astronaut can achieve ingress into or egress out of the space suit interior.

When entering the space suit, the astronaut will enter the suit in a feet first mode and can then subsequently position his or her arms and head within the appropriate upper portions of the suit. Once inside the suit, the astronaut reverses the tilting and sliding operations of the hatch or door closure with respect to the access opening framework of the suit so as to effect closing of the door or hatch. When the suit is then pressurized, the door or hatch closure cannot be opened without exerting a substantial amount of force, such as for example, more than one thousand pounds of force, in order to overcome the pressure/area force imposed upon the door closure. In order to permit the astronaut to easily and readily manipulate the door or hatch closure when the astronaut is inside the space suit, an astronaut-operative cable system is operatively connected to the closure so as to permit the astronaut to properly position and orient the closure with respect to the suit access opening framework whereupon the tongue-and-groove elements and their sealing members may engage each other in order to achieve closing and pressurised sealing of the closure upon the space suit, and the same cable system can be operated by the astronaut so as to disengage the tongue-and-groove elements and the associated sealing members so as to achieve opening of the door or hatch closure with respect to the space suit access opening framework.

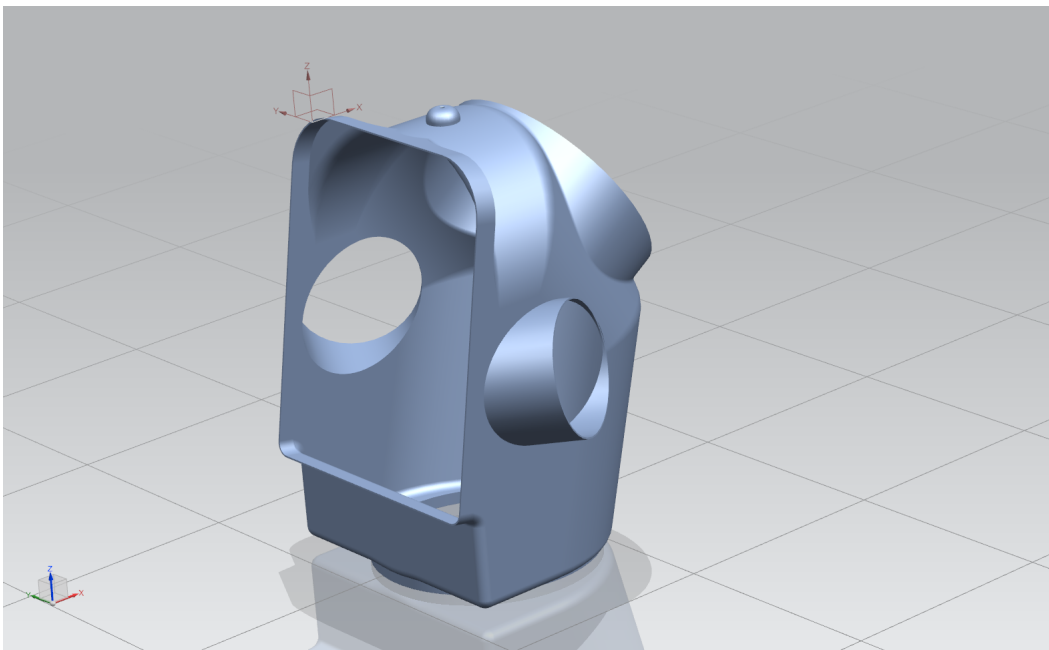
### **5.3 CAD model of HUT**

The model was iterated multiple times from the preliminary design to suit the optimum dimensions and helmet, scye and waist planes for a human in the 95th percentile range. Hatch entry size was also kept in accordance to the airlock dimensions as shown in the figure in *Appendix A*. The NDX airlock opening is 516.4mm

wide and  $641.35\text{mm}$  tall. Helmet ring dimensions were kept constant, i.e using the current helmet design of Aouda.X. Two variations of the same model were made, the difference being the removal of scye extrusions as seen in Fig 5.14.

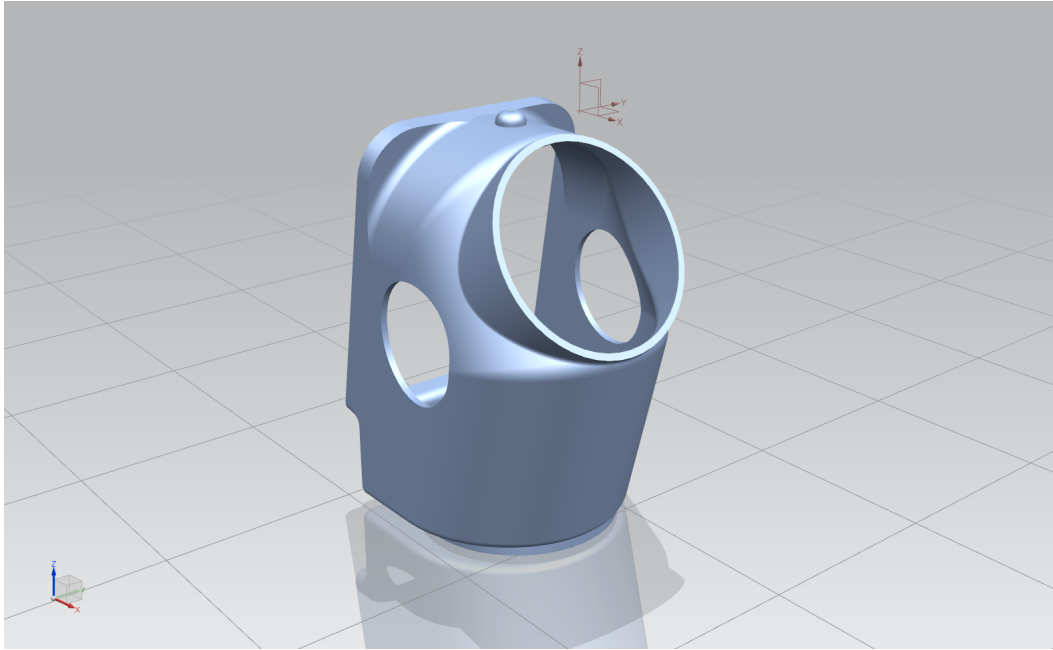


**Figure 5.14:** Front- isometric view of designed HUT

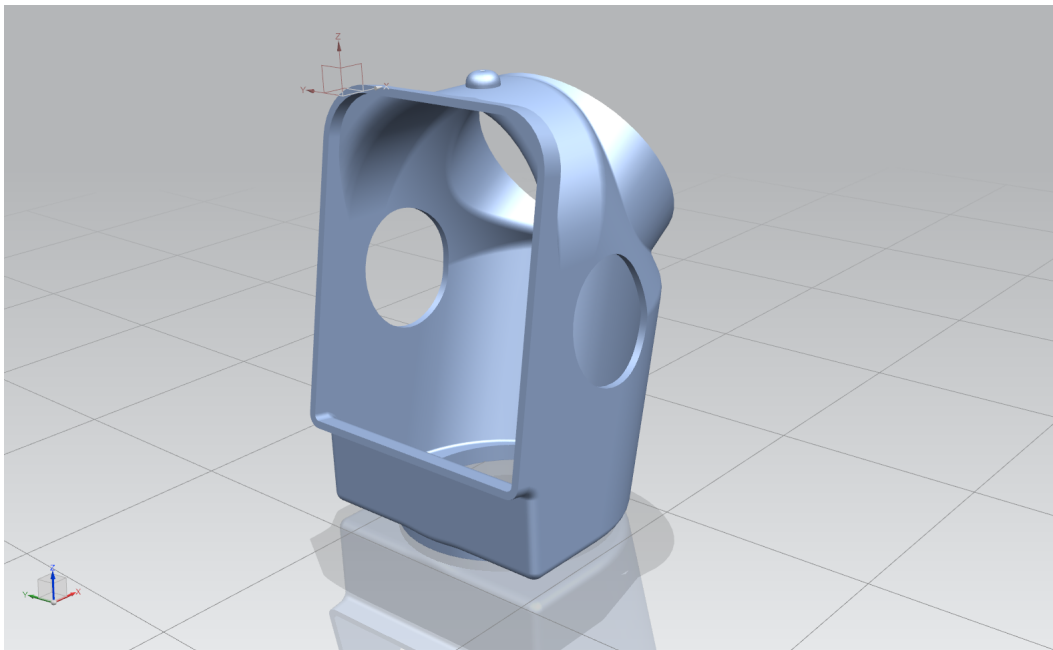


**Figure 5.15:** Back- isometric view of designed HUT

The scye extrusions are shown in Fig 5.14 and Fig 5.15 to indicate the angles at which the scye holes are canted with respect to the HUT. This design is feasible but if the user feels the need for more arm mobility, this extrusion can be removed as seen in Fig 5.16. By eliminating this extrusion, a better Q distance can be achieved as mentioned in section 5.2.1.



**Figure 5.16:** Front - isometric view of designed HUT without scye extrusion



**Figure 5.17:** Back- isometric view of designed HUT without scye extrusion

The final dimensions of the HUT are briefed below (the centre of the scye is taken as the vertical reference plane):

- Helmet dome ring : Diameter =  $428mm$
- Helmet ring angled at  $58^\circ$  from the vertical
- Back hatch angled at  $10^\circ$  from the vertical
- Length and width of rear hatch is  $625.4mm$  and  $510mm$  respectively

- Waist ring : Diameter =  $421mm$  at a distance of about  $427mm$  from the centre of the Scye.
- Scyes each tilted at  $30^\circ$  from the center plane of the HUT body , and cantered inward at  $10^\circ$  to the vertical ; each of diameter  $240mm$ , and further apart from each other by  $621.2mm$
- Thickness of HUT and PLSS is  $2mm$  while the load plate is of thickness  $8mm$

The model provides sufficient tolerance for bending of the waist, viewing angle and rotation of the arms. The CAD draft of the HUT can be found in *Appendix B*.

## 5.4 HUT/PLSS Assembly Configuration

The general life support function is to provide all vital resources to the suited crew member during an EVA sortie as well as the associated preparation and deactivation operations within the airlock of the mothercraft. More specifically, the life support system provides breathing oxygen, pressure control, temperature control, atmosphere revitalization and protection from the external space environment [Möller *et al.*, 1995].

### 5.4.1 PLSS Packaging concepts

Planetary PLSS configurations should have the following characteristics:

- Ease of maintenance
- Technological Flexibility
- Low weight
- Minimal volume

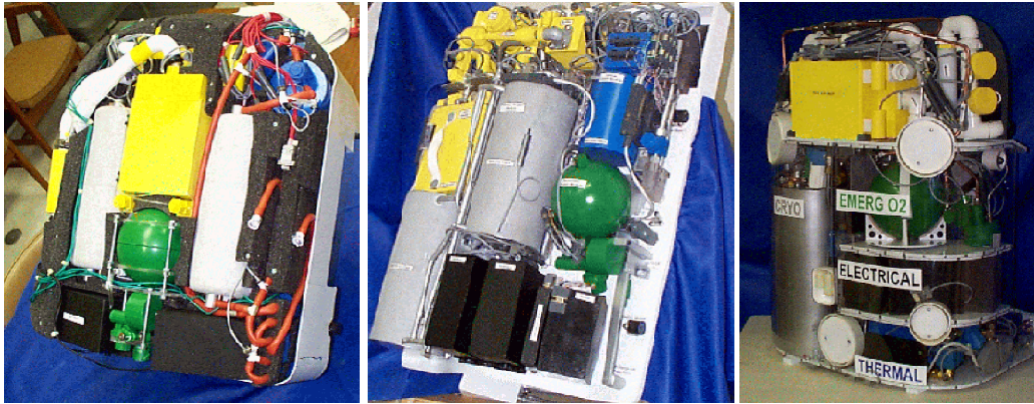
A PLSS development concept devised by NASA evaluated the process of PLSS packaging by targeting maintenance, robustness, mass properties, volume, CG and flexibility as key aspects to a new PLSS packaging configuration [O'Connell *et al.*, 1999].

Three key packaging concepts developed by NASA were : The Foam, Motherboard, and LEGO™ whose concepts share many similarities, yet are unmistakably unique and can be seen in Fig 5.18.

- The **Foam** concept packages all components in a clamshell rigid chamber with stabilization and protection of individual components provided by a foam medium.
- The **Motherboard** design attaches groups of components (modules) to a single mounting plane containing primary module-to-module resource transfer lines.



- **LEGO™** package links together functionally unique, independently packaged subsystems into a complete operational assembly.



**Figure 5.18:** (from left to right) Foam Supported PLSS, Motherboard Packaging Concept and LEGO™ Packaging Concept

*Image: Hoffman [2004]*

The "backpack" or the PLSS portion was designed to be on the outside of the hatch similar to the I-Suit design as opposed to the Orlan designs where the PLSS components were on the inside of the hatch. See Fig 5.19. This is due to the fact that Aouda.X makes use of an internal strap- suspension system (similar to straps used in a hiking backpack) to aid the user in carrying the load of the HUT and PLSS on his shoulders and waist. It helps to keep the shoulders centered in the scye bearings for maximum mobility. This suspension system is situated on the inside of the hatch so the components of the PLSS cannot be placed here. It is possible for this side of the PLSS to have pass throughs for air/ventilation and electric cables.

The external module can easily be replaced and accommodates the PLSS components. The heavier components are mounted to the base of the backpack suit closure. The components are less densely packed into the backpack closure hatch to allow for easy servicing while on Analog missions.

The PLSS and hatch entry size were based on the dimensions of NDX suit port to continue with an Aouda.X - NDX collaboration where the rear entry suit design of Aouda can be made to dock with the suitlock of NDX's suitport (see Fig 5.20) as mentioned in Chapter 4. The interfaces will be potentially located on a load bearing frame around the lower edge of the HUT or on the flange to connect the lower torso [Abramov *et al.*, 2002].

The mockup was designed exclusively from CAD systems as seen in Fig 5.21 . A library of components was constructed and manipulated to produce an efficient 3D layout. The ability to rotate and observe the layout from any view was key to visualizing volumetric loading of components within the contours and interstitial spaces. Resource lines were then routed and instrumentation locations defined. Objects had mass property data attached, to easily and automatically define system mass properties. Air ventilation ducts can be seen on the inner face of the PLSS



**Figure 5.19:** PLSS configuration of the Orlan (*left*) and I-suit (*right*)

*Image: Graziosi et al. [2006]*



**Figure 5.20:** NDX Suitport configuration

*Image: UND Human Spaceflight Laboratory*

and the load plate (in purple). The load plate acts as an interface between the PLSS and HUT and can possibly have docking mechanism attachments in order to dock with the suitport. The side of the load plate on the opposite side of the PLSS has sufficient space to tether suspension straps for the user to securely fasten the PLSS in the HUT. PLSS dimensions can be seen in *Appendix C*.

The assembly of the PLSS with the lower rear portion of the HUT is shown in Fig 5.22 and Fig 5.23 . The load plate is fixed to the entry hatch of the HUT by means of a simple hinge. The internal components of the PLSS , though designed and assembled to suit the configuration of the current Aouda.X design, is not shown here due to intellectual property rights. The assembly is checked on a human model on CAD which matches the approximate anthropometric size range required for using this suit.

**NOTE:** The list of individual PLSS components, their mass budgets and images of the PLSS assembly are strictly confidential for intellectual property reasons and will not be shown in this report. The reader is welcome to contact the author for

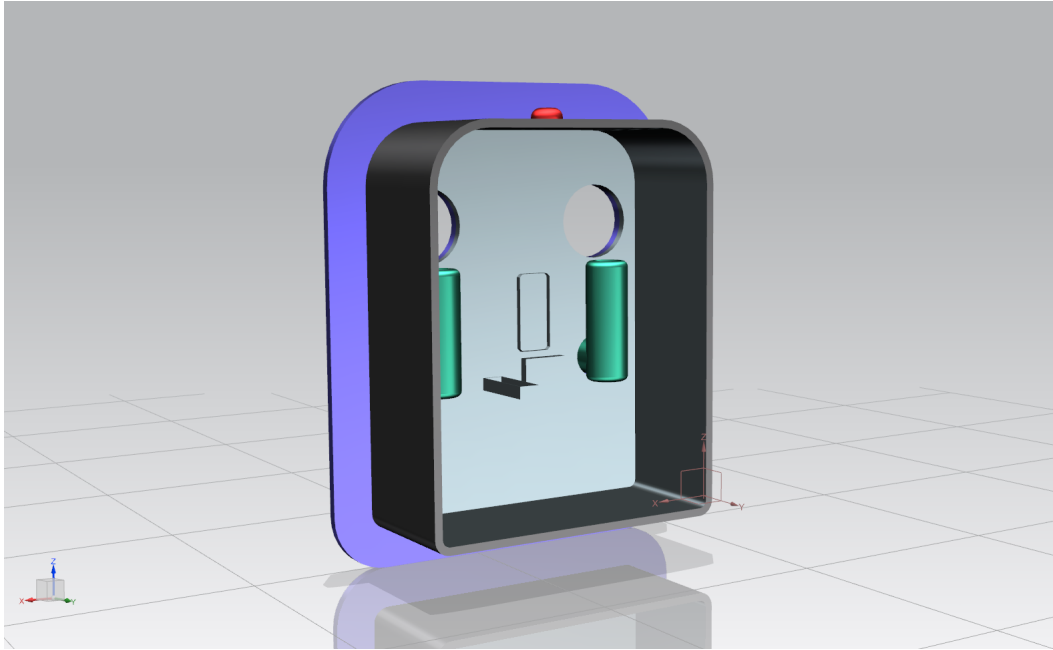


Figure 5.21: PLSS inside view

details about the PLSS.

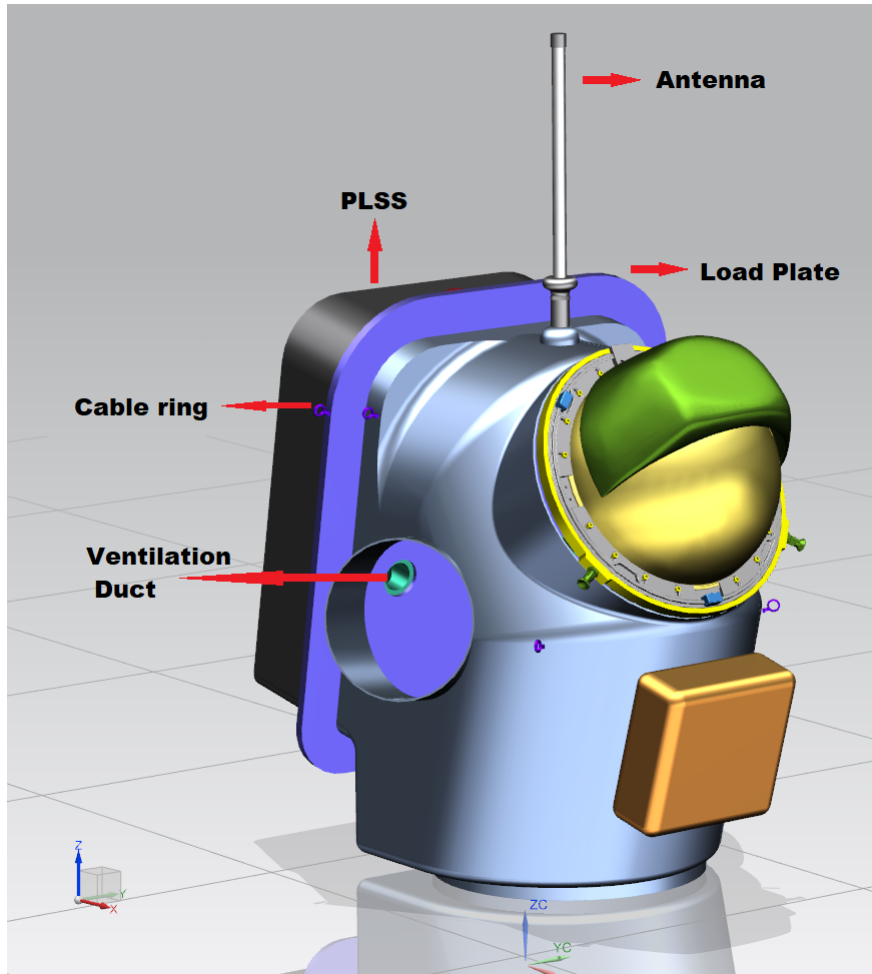
## 5.5 Anthropometric Sizing

HUT sizing depends on various anthropometric values such biacromial breadth, mid shoulder breadth, scye circumference, base of neck to acromion length, suprasternal to acromion length [Reid *et al.*, 2014]. Width of entry is defined by hip breadth (with the underwear and thermal garment taken into account). It is not defined by biacromial width as they are dynamic and can be changed. The hatch dimensions are ideally smaller than normal biacromial length and the shoulder bearing arrangements are crucial Abramov *et al.* [2001]. Small rings for a cable to be drawn through along the HUT for closing and opening the hatch door can be seen in the assembled images.

For Aouda.X, the range of analog astronauts who don the suit are mostly male of the following anthropometric range [Soucek *et al.*, 2015] :

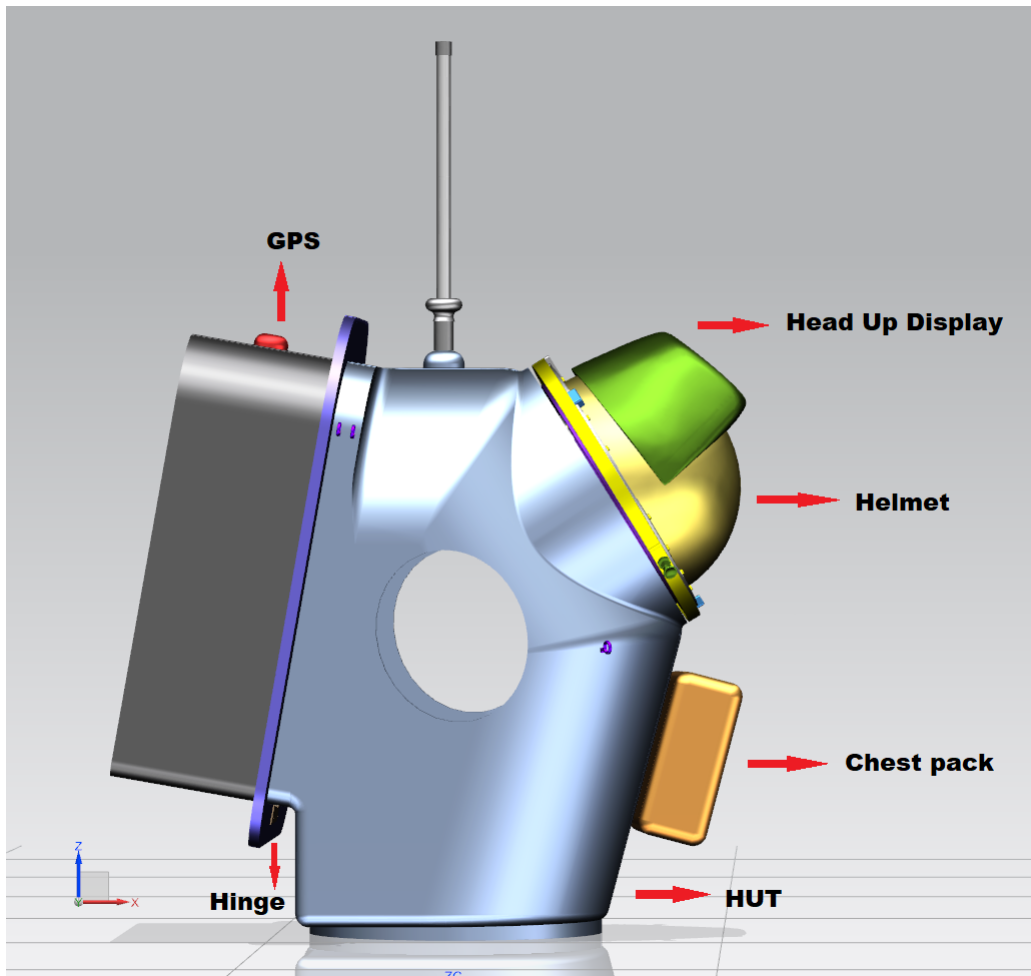
- Mean age:  $33(\pm 4.24)$  years
- Mean body weight :  $77.25(\pm 6.2)$  kg
- Mean height:  $177.5(\pm 5.75)$  cm

For this design, the Anthropometric Dimensional Data for American Male were taken from NASA-STD-3000, the Man-System Integration Standards, Volume I, Section 3 ANTHROPOMETRY AND BIOMECHANICS [Johnson-Throop, 2008]. The stature assumed is for the 95th percentile allowing usage for a wide range of user sizes. In NX, the human modelling tool was set up to define the test subject. The subject was taken from the Army Anthropometric Survey (ANSUR) database



**Figure 5.22:** Isometric view of assembly with scye

which is the military population database of the U.S Army. The subject was a male from the 95th percentile range. The anthropometric dimensions for this range of subjects are shown in Table 5.3.

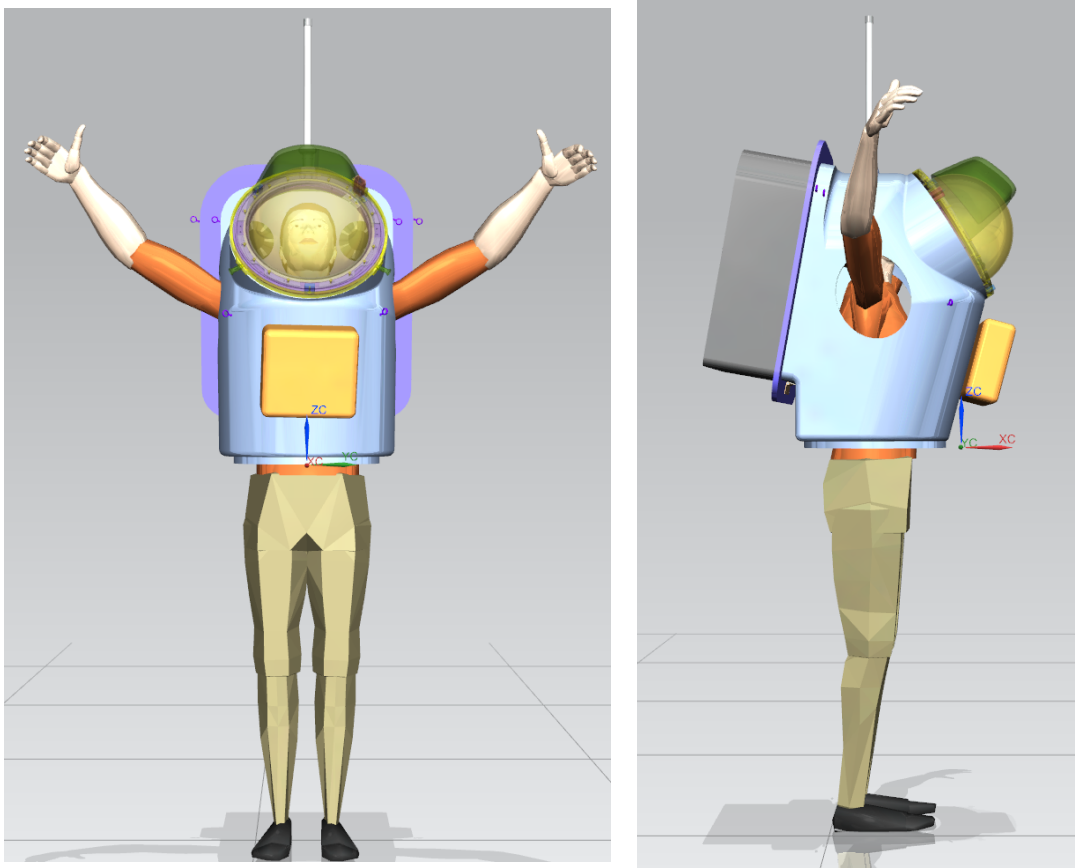


**Figure 5.23:** Side view of assembly without scye extrusion

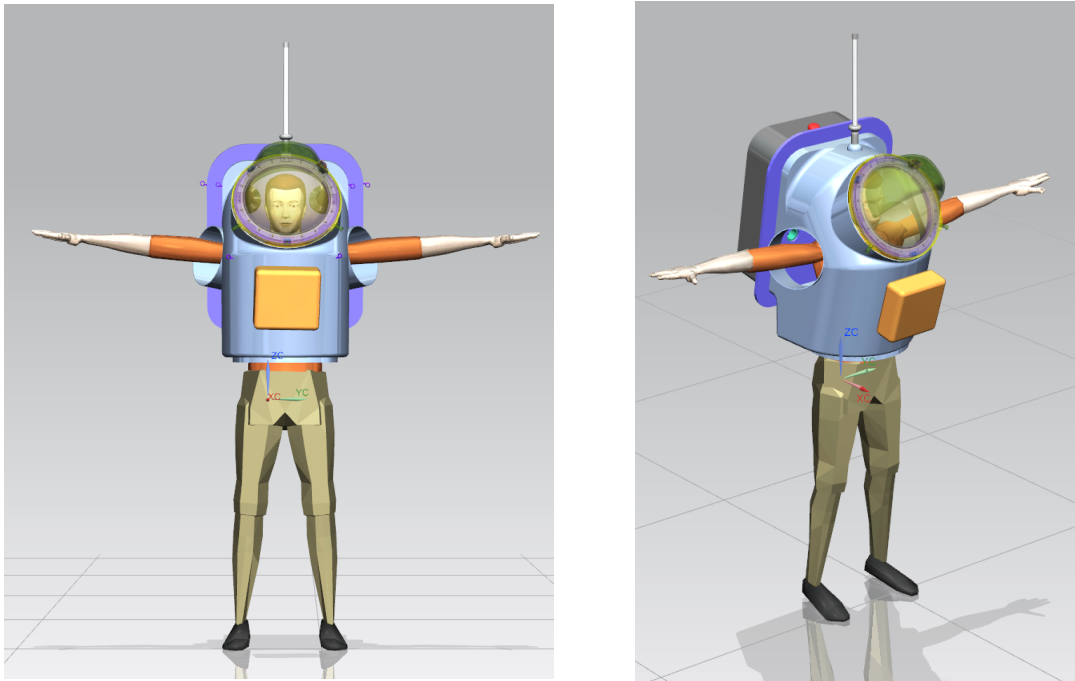
**Table 5.3:** Anthropometric dimensional data for an American male in 1-G conditions

Dimension	95th Percentile (mm)
Abdominal Depth	237.62
Acromion Height	1550.04
Arm Length	865.11
Biacromial Breadth	412.08
Bideltoid Breadth	481.64
Elbow Fingertip Length	511.62
Hand Breadth	96.65
Hand Length	204.68
Head Breadth	152.78
Head Height	235.01
Head Length	201.333
Hip Breadth	372.72
Shoulder Elbow Length	416.34
Stature	1870.00
Weight (kg)	89.00

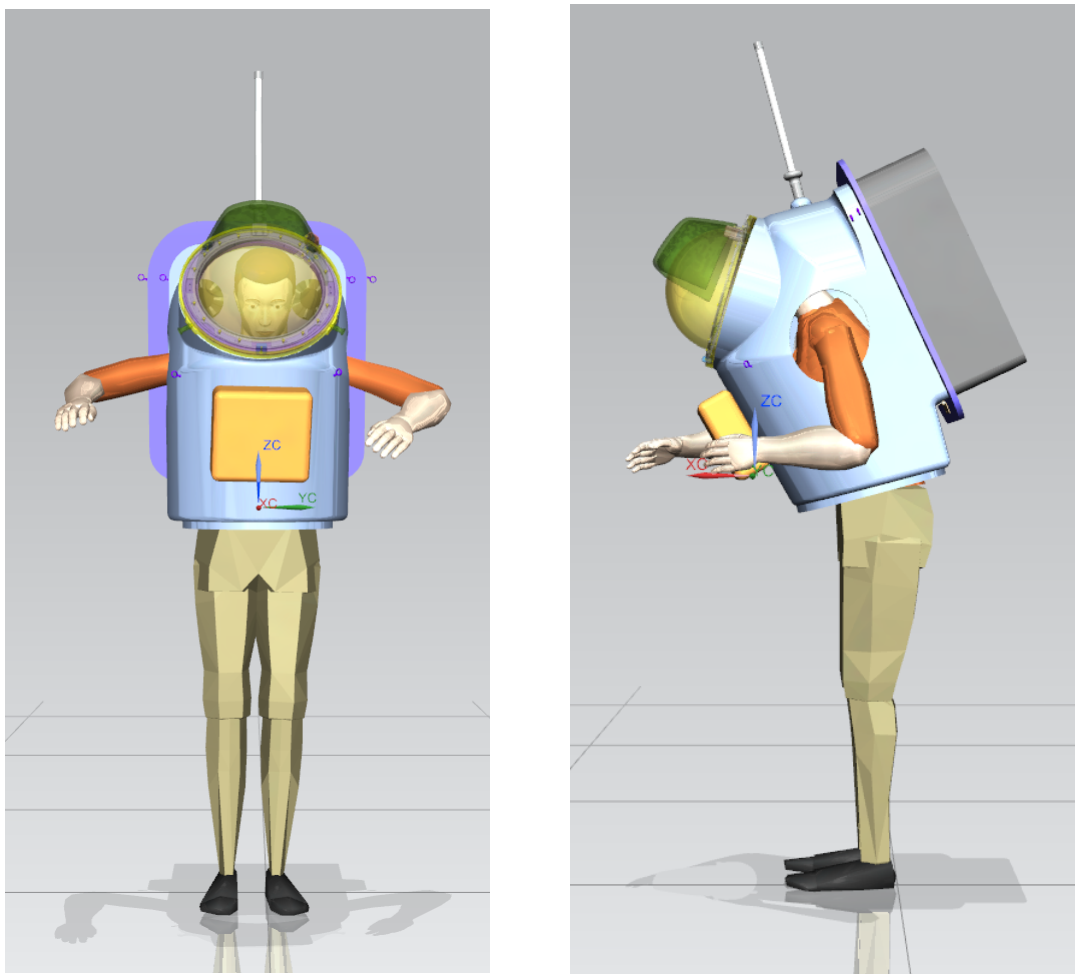
Some of the performance metrics outlined in Section 4.1 were tested on the CAD software through trial and error. Some of the tests involved were checking if the subject can extend his arms (Fig 5.25), reach outwards and upwards (Fig 5.24) , kneel down on both knees (Fig 5.26) and bend forward while working (Fig 5.27).



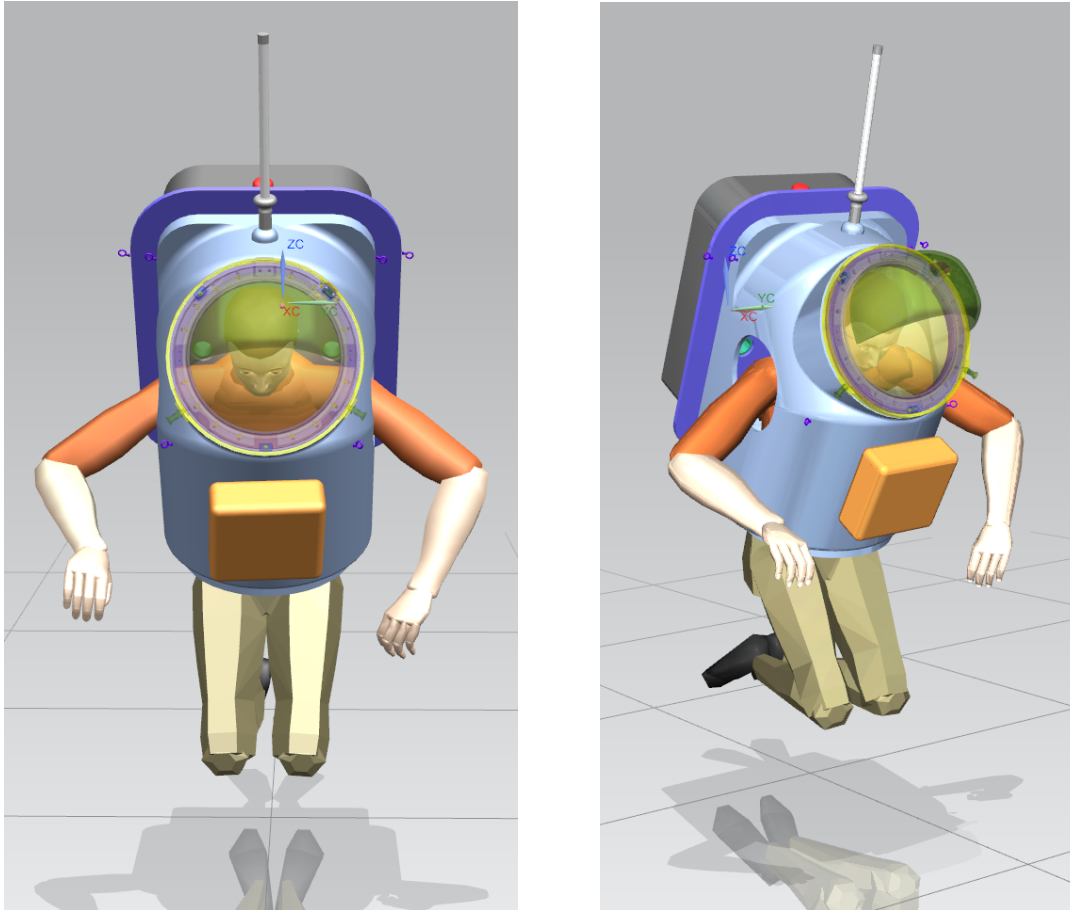
**Figure 5.24:** Stand overhead: Front view (*left*) and Side view (*right*)



**Figure 5.25:** Arms extended: Front view (*left*) and Isometric view(*right*)



**Figure 5.27:** Bending while working: Front view (*left*) and Side view(*right*)



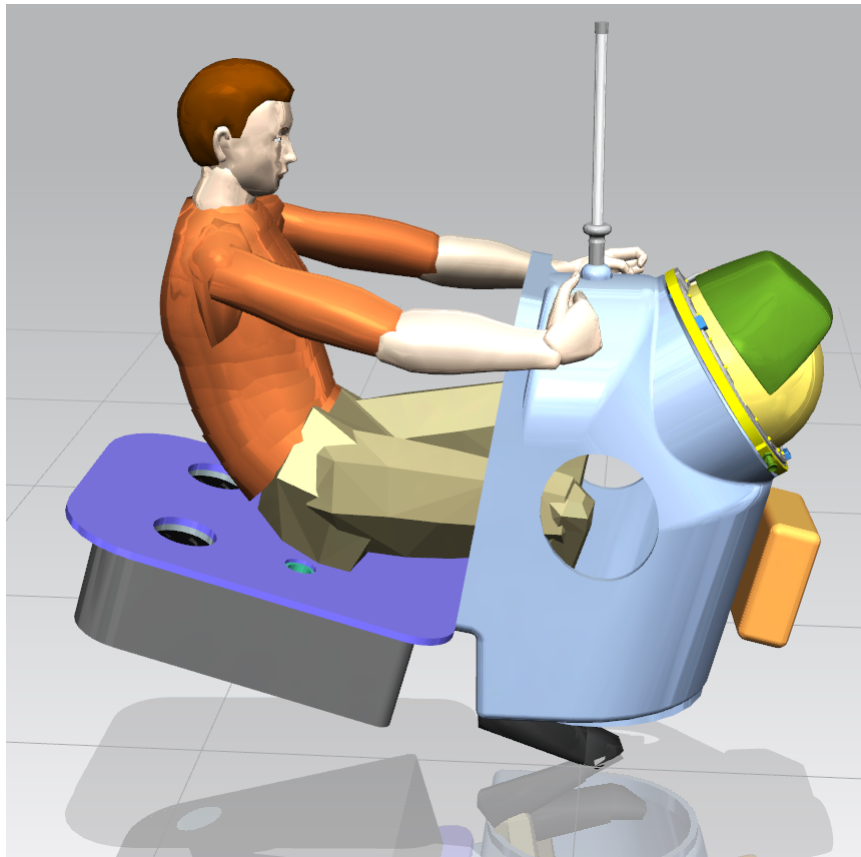
**Figure 5.26:** Kneeling on two knees: Front view (*left*) and Isometric view (*right*)

The suit can be donned by climbing into the suit when the hatch entry is open. For such rear entry suits, there is almost always a need for a donning stand to assist in donning the suit. The stand can be mounted at the hip bearings to prevent the HUT from moving. The user can slide through the hatch (See Fig 5.28 ), adjust his/her suspension straps and insert the arms through the scye openings. Then, the PLSS can be closed against the HUT by pulling on a draw cable to lock the HUT and PLSS in place.

## 5.6 Suitport docking arrangements

The design thus far developed should be able to dock with the NDX suitport and this requires a separate docking mechanism, that is beyond the scope of this project. Some suggestive mechanisms have been identified for future development on this area. The design criteria for the docking mechanism should be focused on two key areas : 1) the alignment of the upper part of the suit and 2 ) latching and sealing. Some conceptual designs developed for this purpose by NASA [*Chartres et al., 2009*] are outlined below. The options can be used in conjunction to provide assistance and feedback to the crewmember as they are unable to see behind them during the





**Figure 5.28:** Donning technique

docking procedure.

### **Guide with Pins and Tapered PLSS**

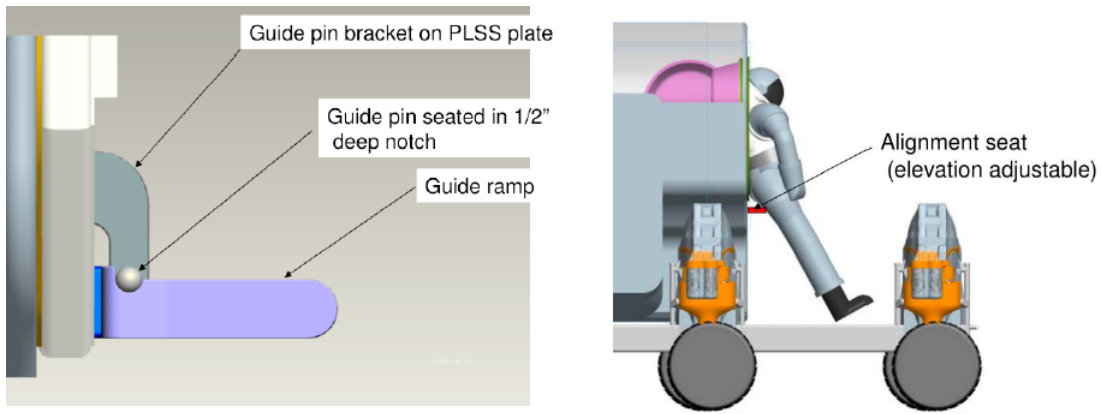
The pins are used for location and alignment providing tactile feedback to the crewmember prior to docking and engagement. The guides allow the pins to follow a predetermined path to ensure proper engagement. A tapered or shaped PLSS, similar to the guide and pins, allows for location and alignment. The taper contour allows initial rough alignment with tactile feedback to the crewmember and the shape guides to the correct final alignment. See Fig 5.29.

### **Exterior Seat**

An exterior seat, shown in Fig 5.29, can also provide assistance to the crewmember to locate the PLSS and give tactile feedback prior to engagement. The seat would also provide a rest point to the crewmember and can be designed to carry some of the load from the suit reducing the loads in the docking mechanism.

### **Tabs and Latches**

The design adopts the moving latch tab chain from the Mark III and incorporates it as part of the rear bulkhead . The design also uses a tapered PLSS to assist



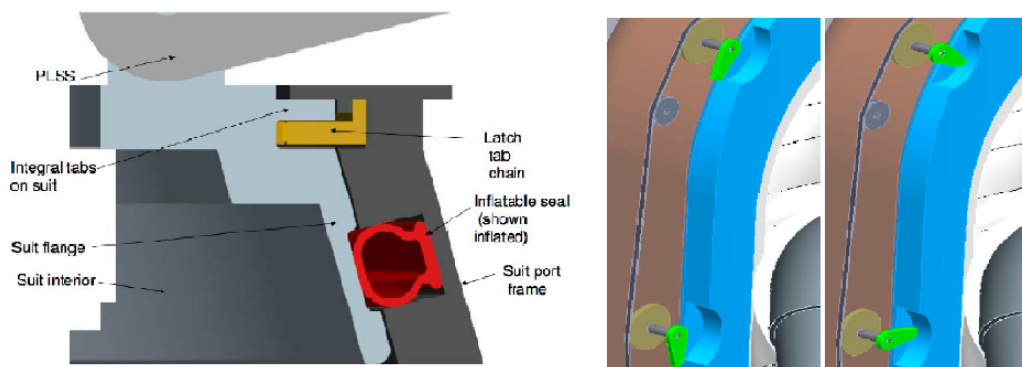
**Figure 5.29:** Example of the guide rails (purple) with pins (silver) (*left*) and Exterior seat to assist crewmember with alignment (*right*)

*Image: Chartres et al. [2009]*

alignment with the rear bulkhead prior to rotating the latch tab chain to the locked position. An inflatable seal as part of the rear bulkhead would provide sealing. The pressurised seal expands towards the suit interior against the suit flange to prevent gas leakage from the habitat. See Fig 5.30.

### Navy Dog Seals

This concept uses engaging dogs to hold the pressure load. The crewmember backs the suit and PLSS into the opening and presses up against the bulkhead where they then engage the dogs. See Fig 5.30.



**Figure 5.30:** Cross Section of Mark III latching tab concept showing the inflatable seal (red) and latching tab chain (gold) (*left*) and Navy dog detail showing disengaged and engaged shaped dogs (green) and the detents (blue) can assist in alignment and latching (*right*)

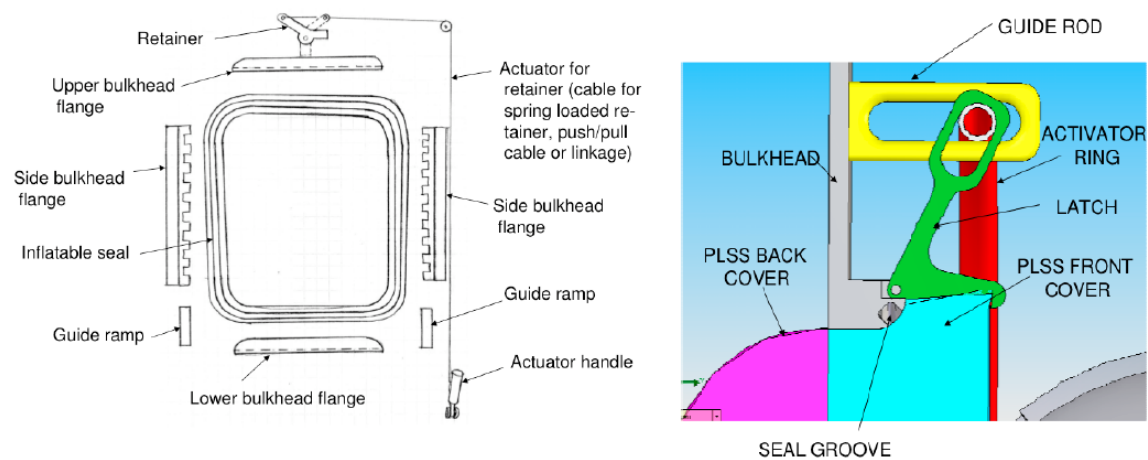
*Image: Chartres et al. [2009]*

## Interlocking Flanges

The simplest implementation of the concept uses a passive design of interlocking flanges to take the pressure load as seen in Fig 5.31. The crewmember uses the guide ramp and pins to initially align with the rear bulkhead. They then slide the pins along the guides backwards towards the bulkhead. The guide ramp is shaped to cause the flanges to move upward and then down to interlock with the bulkhead flange. A retainer is then engaged to hold the flanges in place. The passive nature of the concept also reduces the mass on the bulkhead.

## Multipoint Latch

This concept uses multiple latches spaced around the bulkhead to secure the PLSS against the pressure load. The latches pivot about the bulkhead point located near the seal. Initially the activating ring is rearwards by the bulkhead as the crewmember reverses the PLSS into the bulkhead. Alignment and location is achieved using a shaped PLSS, guides, pins or all of these elements, with tactile feedback given to the crewmember. The crewmember then moves the activator ring via the dual handles located about their waist. The activator ring moves forward within the guide rods and drives the latches to an over-center position locking in the PLSS plate and suit. See Fig 5.31.



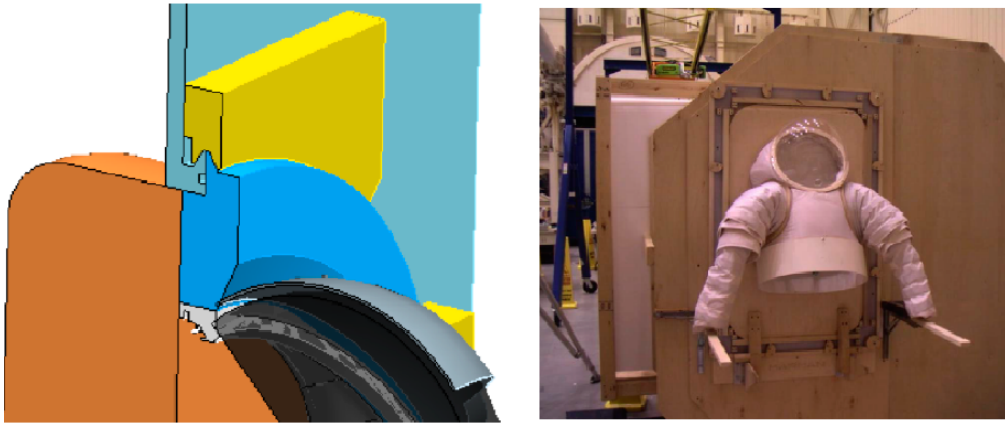
**Figure 5.31:** Interlocking flanges bulkhead detail (*left*) and Detail of the multi-latch concept showing a single latch (green), designed so that they all go overcenter when engaged to secure the PLSS front (aqua). The activator ring (red) slides back and forth in the guide rod (yellow) (*right*)

*Image: Chartres et al. [2009]*

## Marman Clamp

This concept uses a movable V shaped Marman clamp to hold the pressure load. See Fig 5.32. The design is structurally efficient and provides for some self-aligning capability to assist the crewmember. The crewmember would back the PLSS into

the bulkhead possibly with the assistance of a shaped PLSS, guides and pins. Once activated by the engagement mechanism the Marman clamp can then assist in final alignment and latches.



**Figure 5.32:** Marman Clamp detail showing engagement that assists in alignment and latching (*left*) and Marman Clamp mockup using wooden clamp, pulleys and rollers (*right*)

*Image: Chartres et al. [2009]*



# Chapter 6

## Analysis

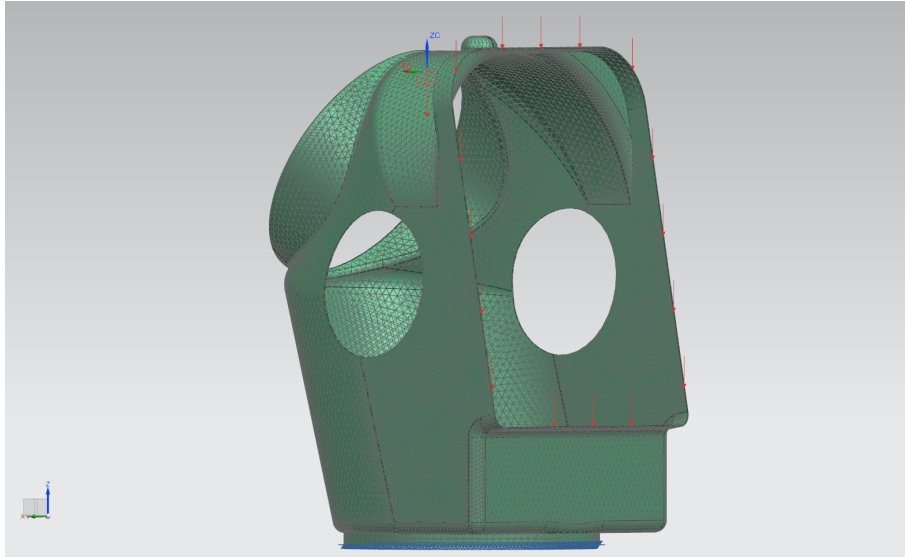
The performance of the designed Rear Entry HUT is very significant for the overall space suit design. The deformation of the structural design is an issue to be addressed and checked to improve further iterations of the design in the future. The finite element method is used to check the load bearing conditions of the HUT with some potential light-weight materials. The entry frame hatch is the major load bearing component of the HUT. The model was first checked for displacements and deformations due to stress in normal 1-G conditions. This was performed to check if there were any deformations due to the self weight of the structure. Then a suitable mass approximation of the PLSS and its components was applied as a load to verify the stability of the structure. The Finite Element Model (FEM) and FEA set up and results are described as follows :

### 6.1 Finite Element Modeling

After completion of the HUT structure ( without scye extrusions) , the CAD model was transferred to the Advanced Simulation application of NX. The analysis type chosen was '*Structural*' under the NX NASTRAN solver with the solution type chosen as SOL 101 Linear Statics - Global Constraints. An ideal geometry of the model was setup and pre-processing involved defining the mesh shape. CTETRA (10) type mesh shells were used with an optimal element size. Then, suitable material was added. In the following cases , the materials S- Glass fiber composite and Kevlar (Aramid) were used in the analysis.

### 6.2 Finite Element Analysis

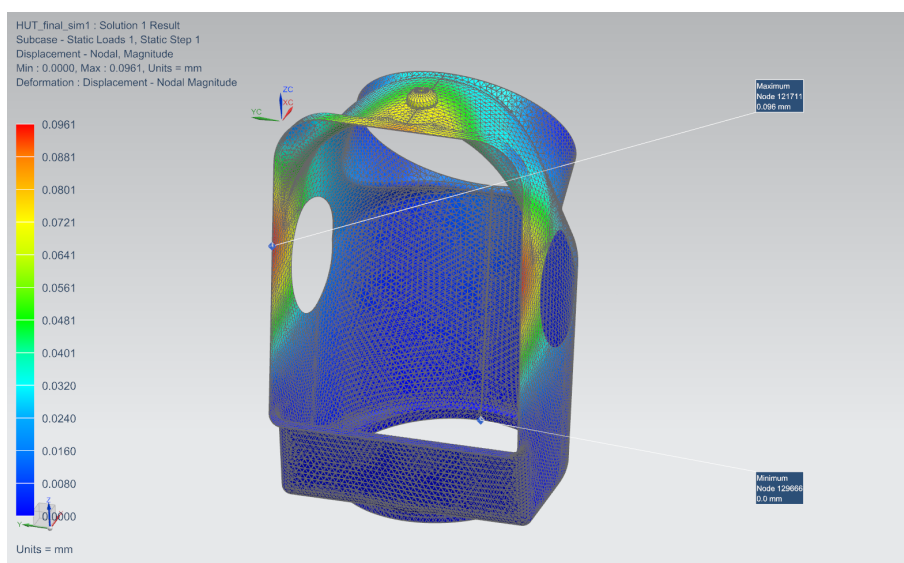
A simulation file was set up to define boundary conditions and constraints on the model. In this analysis , two types of *static vertical stiffness* conditions were observed which are outlined below. Both types of analysis were run on S-Glass Fiber and Kevlar. The FEM and loading conditions set up can be seen in Fig 6.1. For a more in-depth analysis of the composite fiber and resin structure, the NX application of Composite Lamina Analysis is suggested.



**Figure 6.1:** Finite Element Model with force loading, gravity and fixed constraint

### 6.2.1 With 1G acceleration of gravity, calculate the maximum vertical displacement of the HUT and the stress generated on the hatch entry

The FEM was given a fixed constraint at the waist ring and the boundary condition was given as 1-G Gravity load ( $9810\text{mm}/\text{s}^2$ ) in the negative Z direction. The analysis was conducted to check the displacement and stress deformation apparent on the HUT due to its self weight. The results for S-glass and Kevlar can be seen in Fig 6.2 to Fig 6.5 .



**Figure 6.2:** Displacement of S-Glass Fiber Composite HUT under 1G

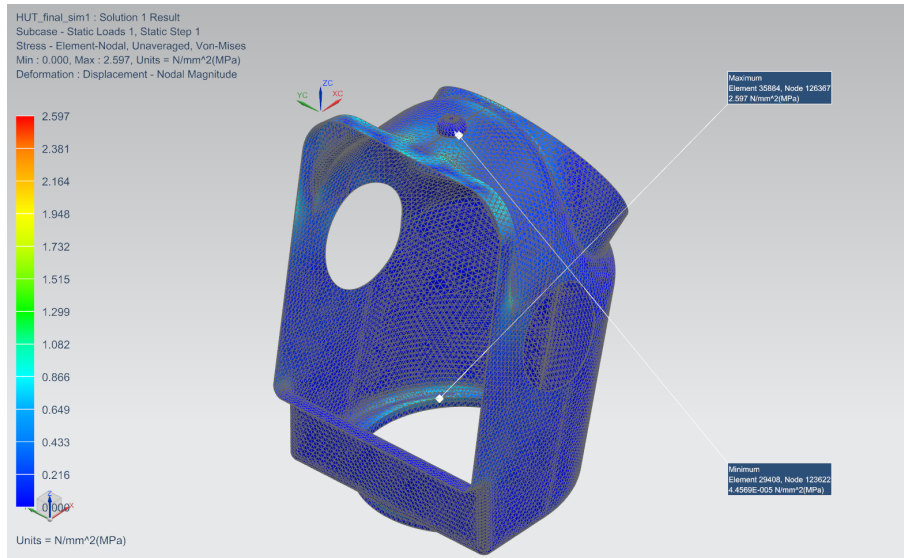


Figure 6.3: Stress deformation of S-Glass Fiber Composite HUT under 1G

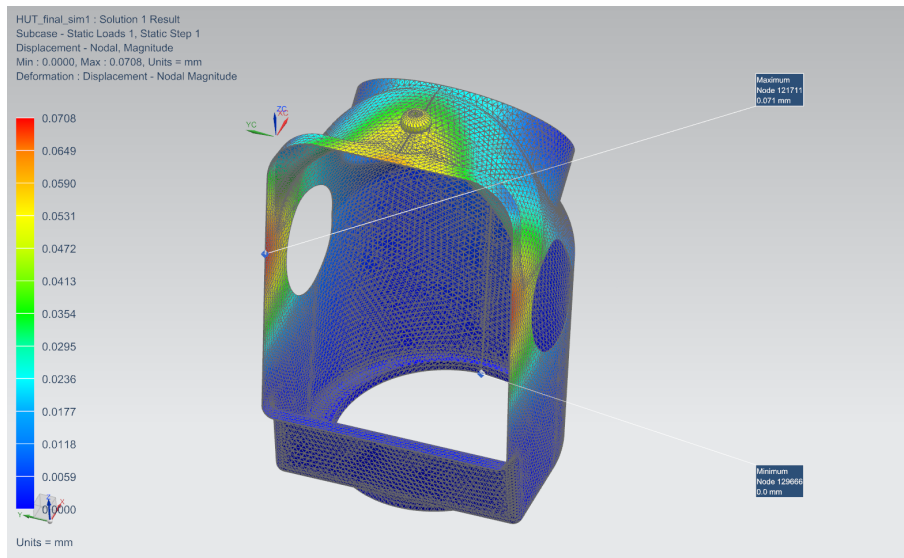


Figure 6.4: Displacement of Kevlar HUT under 1G

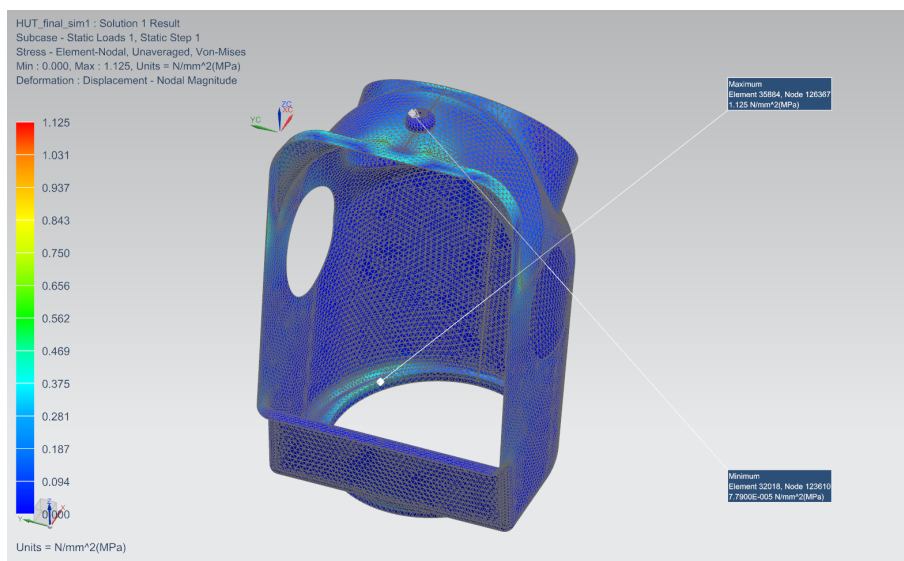


Figure 6.5: Stress deformation of Kevlar HUT under 1G



### 6.2.2 With vertical force of 300N on hatch entry, calculate the maximum vertical displacement of the HUT and the stress generated on the hatch entry

The FEM was given a fixed constraint at the waist ring and the boundary condition was given as 300N in the negative Z direction. The mass of the PLSS, its internal components as well as the drinking bags inside the HUT were assumed to weigh a maximum of 30kg, hence this was applied as force load on the face of the entry hatch that acts as the load bearing plane. The analysis was conducted to check the displacement and stress deformation apparent on the HUT due to the mentioned force load. The results for S-glass and Kevlar can be seen in Fig 6.6 to 6.9 .

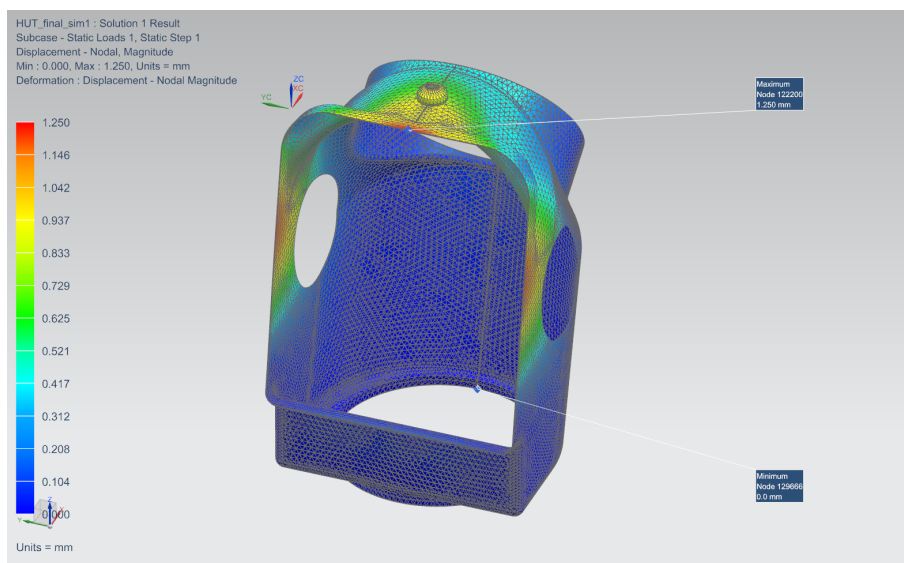


Figure 6.6: Displacement of S-Glass Fiber Composite HUT under 300N

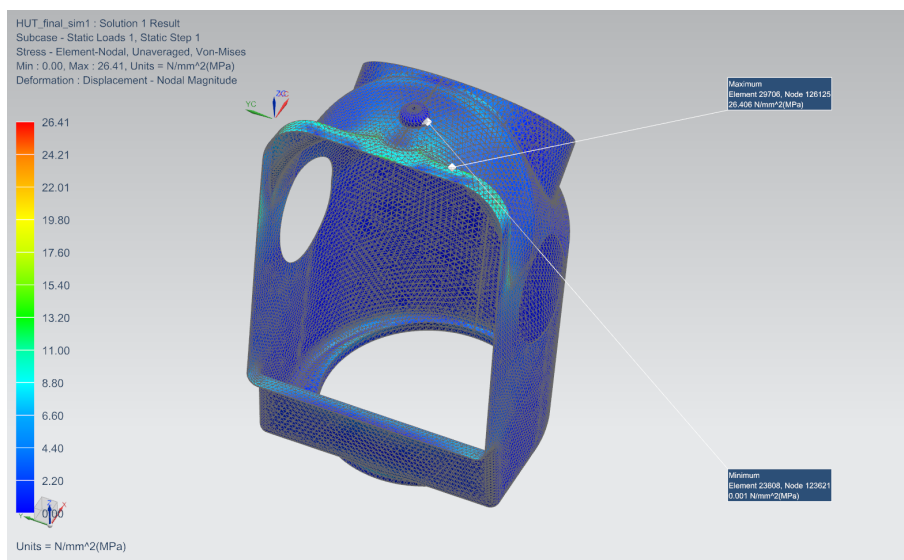
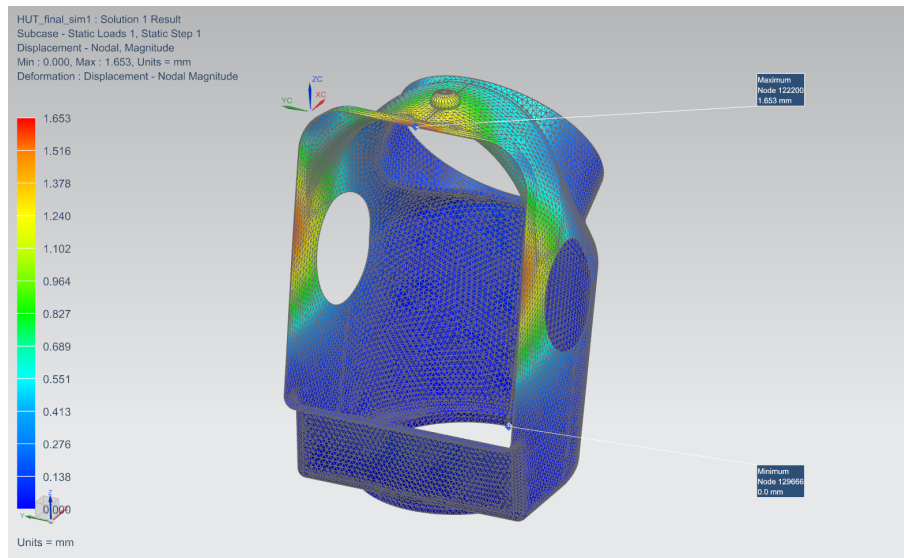
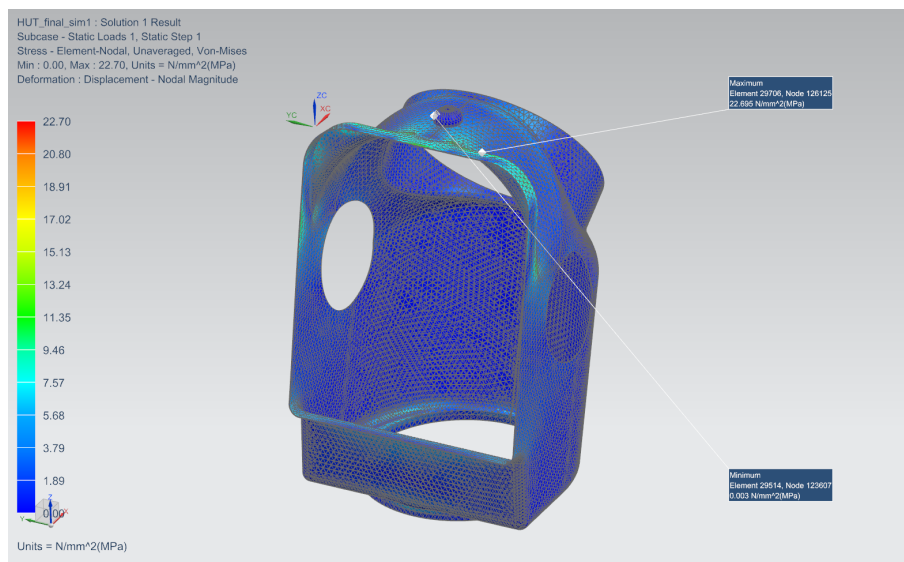


Figure 6.7: Stress deformation of S-Glass Fiber Composite HUT under 300N



**Figure 6.8:** Displacement of Kevlar HUT under 300N



**Figure 6.9:** Stress deformation of Kevlar HUT under 300N

### 6.2.3 Material Selections

The mass of the HUT and empty PLSS (assuming the load plate is made of Aluminium 6061 of density  $2711 \text{ kg/m}^3$ ) with the selected ideal materials are shown in Table 6.1. A comparison rating chart of the selected materials, relative to each other, in terms of their material properties are shown in Table 6.2.

### 6.2.4 Further Material Recommendations

Material selection is a continuous trade-off process where mass and strength of the material should be compromised. Based on previous literature study, some of the

**Table 6.1:** Material Properties and Mass of HUT/PLSS

Material	Density (kg/m <sup>3</sup> )	Young's Modulus (MPa)	Poissons Ratio	Mass of HUT (kg)	Mass of PLSS (kg)
<i>S- Glass Fiber Composite</i>	2490	88000	0.22	5.33	13.77
<i>E- Glass Fiber Composite</i>	2630	72500	0.22	5.63	13.99
<i>Kevlar (Aramide)</i>	1350	63600	0.36	2.89	12.05
<i>Carbon Fiber Reinforced Polymer (CFRP)</i>	1600	142000	0.5	4.43	12.43
<i>EPGC 202 Fiber Glass Composite ( used currently in Aouda.X )</i>	2000	25000	0.3	4.28	13.04

materials used in rear entry suits and their manufacturing capabilities are described below:

The HUT of the Orlan DMA was manufactured from welded stressed Aluminium stamping . Welding - Tungsten Inert Gas (TIG) and resistance welding was inexpensive , easy to modify and provided a strong frame. The ZPS Mk I was also machined from solid block of 6061-T6-Aluminium. It was more expensive compared to welding but resulted in less leakage and load failure. [Harris, 2001]. The suit also made use of Teflon for scye bearing pressure seals. Metal HUTs would result in a heavier suit and may not be ideal for Planetary spacesuits as the Orlan suits were used in the microgravity of space.

The materials for the NDX-1 HUT were selected on the basis of strength, rigidity, ease of hardware attachment, and mass. Based on an evaluation of expected pressure and applied loads on the HUT, a variety of composite sandwiches were considered. To significantly improve the HUT's rigidity without substantially increasing mass, a Nomex® honeycomb core material was tested in two different types of carbon fiber sandwich coupons. The backpack is designed to be lightweight and to partially conform around the HUT in order to stabilize the backpack load. The backpack

**Table 6.2:** Comparison rating chart of Glass, Aramid and Carbon Fibre :  
E=Excellent, G=Good, P=Poor, F=Fair

Source: *deMerchant [2017]*

	Glass	Aramide	Carbon Fiber
<b>Cost</b>	E	F	P
<b>Weight to Strength Ratio</b>	P	E	E
<b>Tensile Strength</b>	E	E	E
<b>Compressive Strength</b>	G	P	E
<b>Stiffness</b>	F	G	E
<b>Fatigue Resistance</b>	G-E	E	G
<b>Abrasion Resistance</b>	F	E	F
<b>Sanding/Machining</b>	E	P	E
<b>Conductivity</b>	P	P	E
<b>Heat Resistance</b>	E	F	E
<b>Moisture Resistance</b>	G	F	G
<b>Resin Adhesion</b>	E	F	E
<b>Chemical Resistance</b>	E	F	E

is constructed using a fiberglass and core material sandwich for improved rigidity [*de León et al.*, 2006].

The strength of metal and composite materials is comparable to the strength of textiles at the same thickness. However, flexural stiffness and impact resistance also dictate metal and composite thickness and construction. Upper torsos made of Dacron fabric, Aluminium and fiberglass reinforced epoxy materials do exist and can be compared such as those used on the Shuttle EMU, rear entry I-suit and the ZPS MK-III suit [*Ferl et al.*, 2006].

For the Z-2 suit, a composite upper torso (including hatch) and brief were proposed. The composite components of Z-2 are required to withstand a prescribed internal pressure within the limit of the allowable volumetric expansion and rate of leakage, and most importantly to withstand all possible impact loading conditions that may arise during operation under gravitational loading conditions on the lunar surface. The materials, S-glass (improved strength E-fiberglass) and IM10 (carbon fiber), are materials currently being used in Z-2. The final design for Z-2 is a sandwich structure of S-glass and carbon fiber [*Ross et al.*, 2014].

A new hybrid composite material was further developed for the Z-2 HUT that consists of a few inner and outer layers of S2 glass/epoxy resin prepreg sandwiching a much thicker IM10/epoxy resin prepreg core. This approach provided the best balance between impact resistance, strength and mass resulting in a final HUT shell weight of 3.17kg. Hybrid aluminium and composite hatch was used for PLSS [*Graziosi et al.*, 2016].

With a lower space-vehicle/habitat to suit pressure combination, fewer rigid components need be utilized in the space suit enclosure. This has the benefit of allowing much of the enclosure to be built from modern, rugged fabrics and possibly light carbon composites rather than metals. From studies on the NDX-1, it has been found that a space suit enclosure using a restraint (shaping) layer of Zylon and a para-aramid shows promise. This type of textile, which has emerged just in the last few years, was used in the enclosure of the NDX-1 Mars Surface Suit Demonstrator. It was chosen because it has high tensile strength and flexibility, is resistant to abrasion and displays good bias elasticity. It also is cut resistant (high trapezoidal strength of the warp and fill fibers), has excellent resistance to rip propagation and is thermally stable. Zylon/para-aramid is as well easy to join with readily available bonding adhesives and is commercially available. Its tradeoffs are that it is onerous to shear by common mechanical methods and in moderate deniers it is relatively thick and can be arduous to stitch. Moreover, it forms thick seams once sewn, requiring creative methods to attach it to hard elements such as wrist rings, etc [*LHarris et al.*].

In terms of material and manufacture, although previous Orlan designs made use of Aluminium as their HUT material, with advancements in material research, potential composites and fibre glass could be implemented on the HUT structure and metals can be selected for the load bearing structures such as frames / flanges. For improving rigidity without increasing mass, composites such as Dacron and Nomex can be tested with a honeycomb structure. Another new technology being implemented on NDX-2 Malleable Hybrid suit is the usage of a Polyurethane bladder which consists of fiber glass mesh cells filled with Isoprene.

Joints of the LTA and waist portion of HUT can make use of rubber, cotton fabrics or leather to reduce overall weight. Teflon lining can be implemented in the thermal garments as well as employed by the users of the I-suits to easily don/ doff with minimal friction. Materials like Bonded Velcro can be used to attach small, light weight components within the suit like for e.g., the drinking bag.

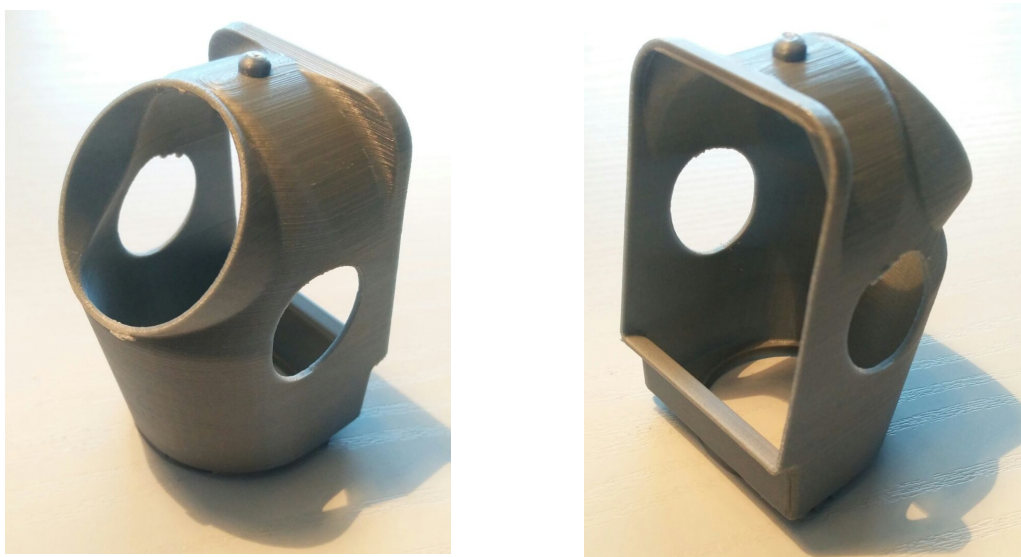
Overall the materials can be chosen on the basis of safety, durability, cost, and tests at an analog site.

# Chapter 7

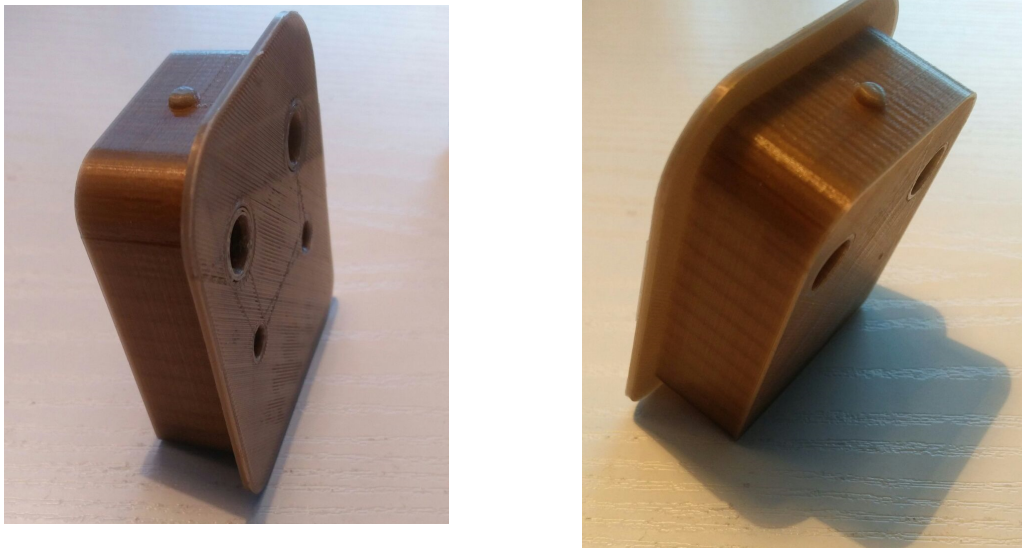
## Prototype Development

The final milestone of this project was to produce a small scale version of the designed rear entry model. This was done by rapid prototyping in a 3D printer. In order for the model to be of optimal size to fit the printer, the HUT and the PLSS were both scaled down to 10% its original size. The wall thickness was set to  $1.05\text{mm}$  and the infill density to 30% so that the structure had some stiffness. Additional internal support structure was added where needed and the product was printed using Polylactide (PLA) plastic.

The 3D printed prototypes can be seen in Fig 7.1 and Fig 7.2 for better visualization of the designed model.



**Figure 7.1:** Front and back views of 3D printed HUT



**Figure 7.2:** Front and back views of 3D printed PLSS

# Chapter 8

## Conclusion and Further work

A compatible design meeting the requirements addressed in the initial chapters has been suitably identified. The design is functional, featuring a back hatch and self-sealing/locking mechanism in addition to accommodating the current PLSS components and interfaces of Aouda.X.

This extensive study provided a lot of interesting information related to rear entry suits and their sequential development. There is much room for improvement and modification considering this is the very first iteration of the design for Aouda.X. Testing the design with the additional suit components can be carried out. For example, the LTAs consisting of expandable fabric joints for a variety of LTA sizes can be designed according to the waist ring of the suit and suitable design changes can be made. Attachment points for scye bearings and sleeves can also be looked upon as future developmental work.

Various types of locking mechanisms can be explored as well from simple gasket seal mechanisms used in refrigerators to complicated gear / bearing based mechanisms. Docking mechanism for Suitports can also be investigated in detail.

The focus in this project was more on modeling the interior space as defined by the relationship between scye, helmet ring, back plane, and waist ring. A 3-D printed, down scaled design was the final target of this thesis although future space suit developers can build upon the design to create potential wooden mockups to test the model first-hand. A low-resolution prototype can approximate a generic rear-entry HUT design.

Some further suggestions for future work includes the following [*Webbon et al.*, 2007]:

- design refinement of the final concepts
- include equipment and systems such as umbilicals and cleaning systems
- produce high fidelity weight/volume/power estimates
- fabricate prototype suitport mechanisms for evaluation and testing with dust simulants
- fabricate full-scale mockup(s) for human factors testing



- system level testing with dust simulants
- using digital mannequins for testing population range coverage

Further tradeoff optimization studies in terms of performance, weight, safety, cost and reliability which are essential can be performed. It is hoped the project can be pursued further with more and better resources, including more realistic prototypes and more thorough design and engineering analysis over a wide range of parameters. Overall , the ultimate goal is to continue with more prototype iterations and tests on Aouda.X to eventually make use of rear entry suits on planetary surfaces such as Mars.

# List of Abbreviations

<b>AA</b>	Analog Astronaut
<b>ANSUR</b>	Army Anthropometric Survey
<b>CAD</b>	Computer Aided Design
<b>CG</b>	Center of Gravity
<b>COMEX</b>	The Compagnie Maritime d'Expertises
<b>COMM</b>	Communications
<b>DCM</b>	Display Control Module
<b>EMU</b>	Extravehicular Mobility Unit
<b>ESA</b>	European Space Agency
<b>ESSS</b>	European Space Suit System
<b>EVA</b>	Extra Vehicular Activity
<b>FEM</b>	Finite Element Model
<b>FEA</b>	Finite Element Analysis
<b>GPS</b>	Global Positioning System
<b>HUD</b>	Head Up Display
<b>HMD</b>	Head Mounted Display
<b>HUT</b>	Hard Upper Torso
<b>ILC</b>	International Latex Corporation
<b>ISS</b>	International Space Station
<b>JSC</b>	Johnson Space Center
<b>LSS</b>	Life Support System
<b>LTA</b>	Lower Torso Assembly

**NASA** National Aeronautics and Space Administration

**OBDH** On-board Data Handling

**ÖWF** Österreichisches Weltraum Forum

**PCB** Printed Circuit Boards

**PLA** Polylactide

**PLSS** Portable/Personal Life Support System

**PSS** Planetary Space Suit

**PXS** Prototype Exploration Suit

**RKA** Russian Space Agency - Roscosmos

**SUT** Soft Upper Torso

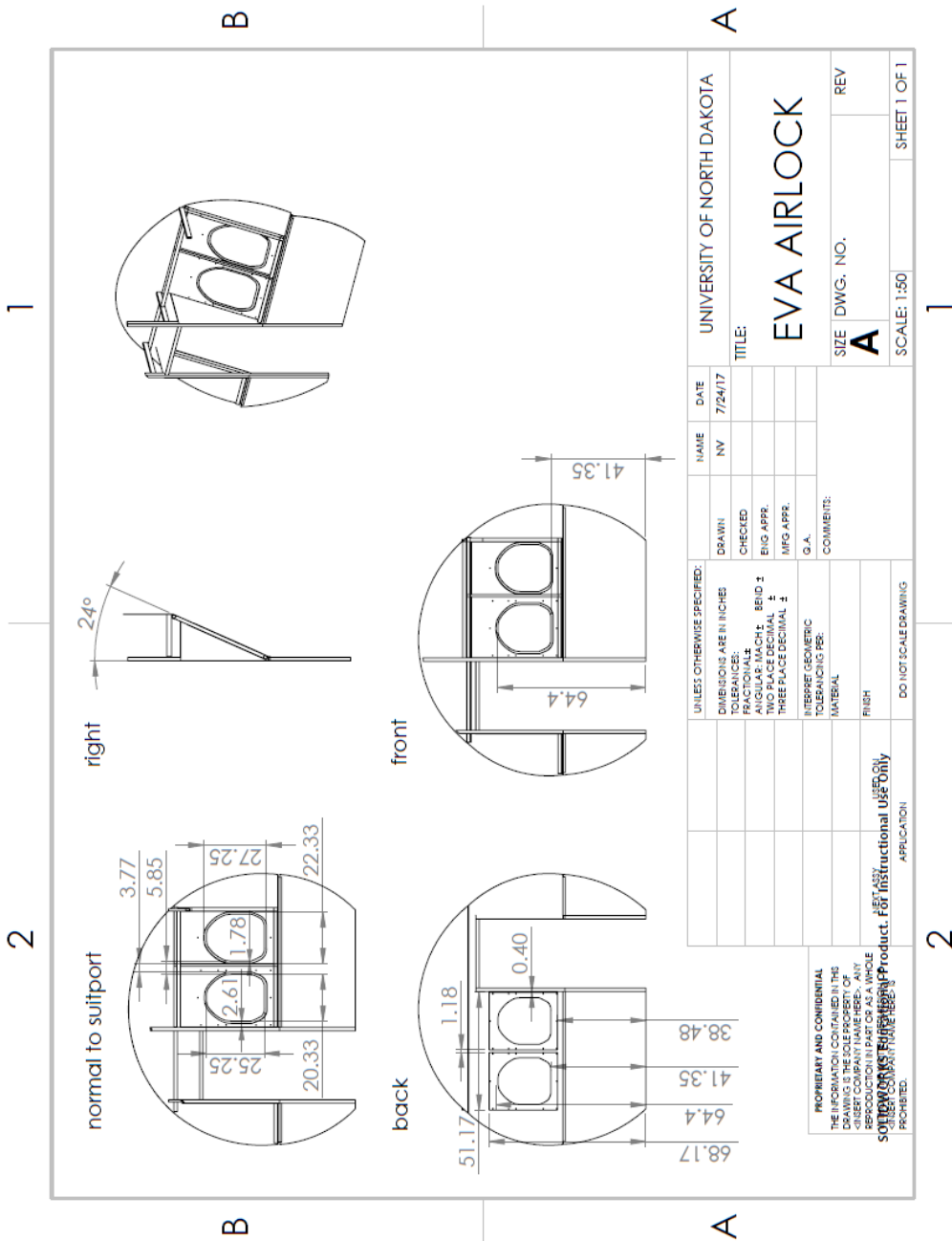
**UND** University of North Dakota

**X** X-Ray

**ZPS** Zero Pre-Breathe

# Appendix A

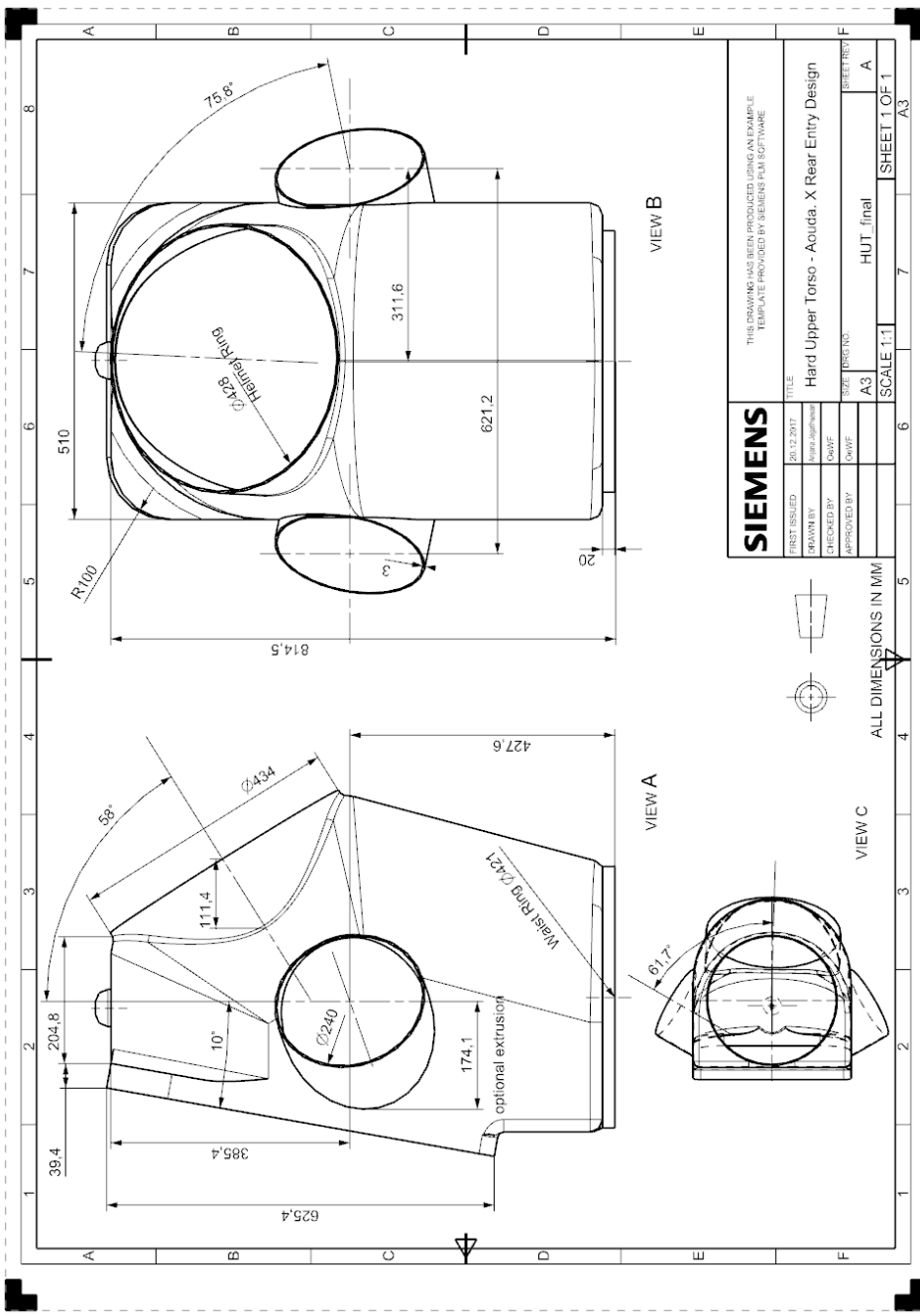
## NDX EVA Airlock- Draft





# Appendix B

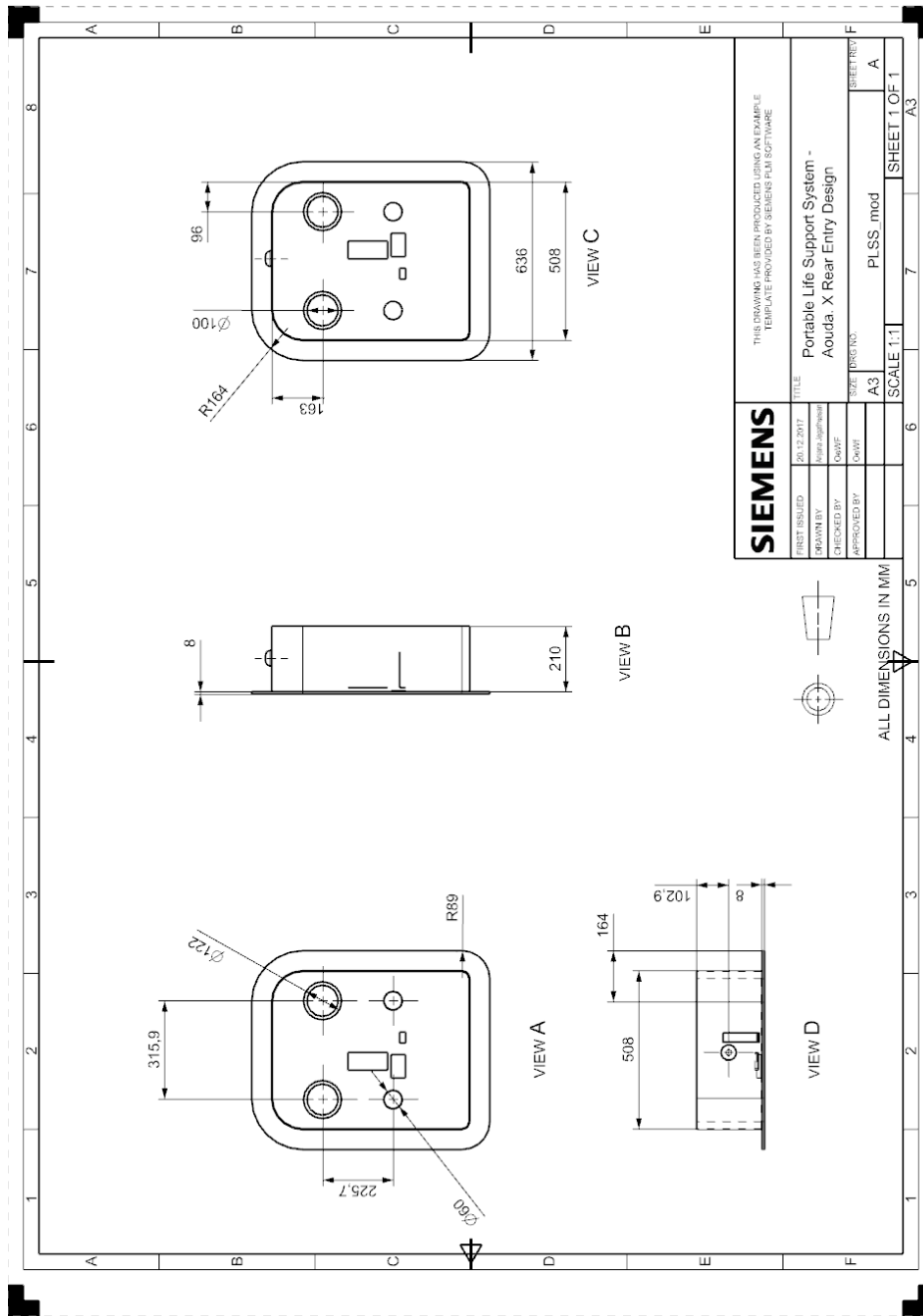
## HUT- Draft





# Appendix C

## PLSS- Draft





# Bibliography

- Abramov, I., N. Moiseyev, and A. Stoklitsky, Concept of space suit enclosure for planetary exploration, *Tech. rep.*, SAE Technical Paper, 2001.
- Abramov, I., N. Moiseyev, and A. Stoklitsky, Concept of mechanical interfaces for planetary space suit to airlock and rover, *Tech. rep.*, SAE Technical Paper, 2002.
- Abramov, I., N. Moiseyev, and A. Stoklitsky, Some problems of selection and evaluation of the martian suit enclosure concept, *Acta Astronautica*, 57(12), 901–909, Elsevier, 2005.
- Aeronautics, U. S. N., S. Administration, and G. W. Bush, *The vision for space exploration*, NASA Headquarters, 2004.
- Blagonravov, A., Collected works of К.Е Tsiolkovskiy, reactive flying machines, NASA Technical Translation, USSR Academy of Science Publishing House, Moscow, 1954.
- Chartres, J., B. Koss, C. Brivkalns, B. Webbon, B. Romig, and C. Allton, Preliminary development of a suit port for planetary surface eva—design studies, *Tech. rep.*, SAE Technical Paper, 2009.
- Cohen, M. M., The suitport’s progress, 1995.
- de León, P., M. Williamson, S. de Silva, J. Untener, and G. L. Harris, The development of a planetary suit concept demonstrator by the north dakota space grant consortium, *Tech. rep.*, SAE Technical Paper, 2006.
- Dean, W. C., Pressure assist hatch closure, uS Patent 6,256,786, 2001.
- deLeon, Suitport concept, <https://www.human.space.edu/projects/suitport.htm>, 2016.
- deMerchant, C., Comparison of carbon fiber, kevlar® (aramid) and e glass used in composites for boatbuilding., <https://www.christinedemerchant.com/carbon-kevlar-glass-comparison.html>, 2017.
- Dionne, S., et al., A comparison of pressure suit systems architectures for the space exploration enterprise, *Tech. rep.*, SAE Technical Paper, 2006.

- Durante, M., and C. Bruno, Impact of rocket propulsion technology on the radiation risk in missions to mars, *The European Physical Journal D-Atomic, Molecular, Optical and Plasma Physics*, 60(1), 215–218, Springer, 2010.
- Ferl, J., L. Hewes, D. Cadogan, D. Graziosi, and K. Splawn, System considerations for an exploration spacesuit upper torso architecture, *Tech. rep.*, SAE Technical Paper, 2006.
- Graziosi, D., J. Ferl, and K. Splawn, An examination of spacesuit entry types and the effects on suit architecture, *Space*, 5969, 2004, 2004.
- Graziosi, D., J. Ferl, and K. Splawn, Evaluation of a rear entry system for an advanced spacesuit, *Tech. rep.*, SAE Technical Paper, 2005.
- Graziosi, D., W. K. Splawn, J. Ferl, and A. J. Ross, Evaluation of the rear entry i-suit during desert rats testing, *Tech. rep.*, SAE Technical Paper, 2006.
- Graziosi, D., R. Jones, J. Ferl, S. Scarborough, L. Hewes, A. Ross, and R. Rhodes, Z-2 architecture description and requirements verification results, 46th International Conference on Environmental Systems, 2016.
- Groemer, G., *Aouda System Handbook*, ÖSTERREICHISCHES WELTRAUM FORUM, 2016.
- Groemer, G., et al., The MARS 2013 Mars analog mission, *Astrobiology*, 14(5), 360–376, Mary Ann Liebert, Inc. 140 Huguenot Street, 3rd Floor New Rochelle, NY 10801 USA, 2014.
- Harris, G. L., *The origins and technology of the advanced extravehicular space suit*, San Diego, Calif. : Published for the American Astronautical Society by Univelt, ISBN 0877034818, 2001.
- Hoffman, S. J., Advanced eva capabilities: A study for nasa’s revolutionary aerospace systems concept program, 2004.
- Johnson-Throop, K., Anthropometry and biomechanics, <https://www.msiss.jsc.nasa.gov/sections/section03.htm>, 2008.
- Jones, H., Planetary airlock and suitlock requirements and alternate approaches, *Tech. rep.*, SAE Technical Paper, 2007.
- Katuntsev, V. P., Y. Y. Osipov, and S. N. Filipenkov, Biomedical problems of eva support during manned space flight to mars, *Acta Astronautica*, 64(7), 682–687, Elsevier, 2009.
- Kozloski, L. D., U. S. Space gear: Outfitting the astronaut, *Washington: Smithsonian Institution Press, 1994.*, 1994.
- Kuznetz, L. H., and O. Gwynne, Space suits and life support systems for the exploration of mars, *British Interplanetary Society, Journal*, 45(5), 215–224, 1992.

- Lexen, T., Inner space: Some thoughts on inside hand access for a surface eva suit, 46th International Conference on Environmental Systems, 2016.
- LHarris, G., P. G. de Leon, and M. Williamson, Some thoughts on the architecture of a planetary extravehicular space suit, *Tech. rep.*, NASA, 2006: 14-17.
- Mann, A., The evolution of the spacesuit, <https://www.wired.com/2011/10/spacesuit-evolution>, 2011.
- Masters, D., Development of Aouda.X spacesuit caution and warning system algorithms for mars analog mission extravehicular activity: Monitoring thermal stress, workload, and fatigue, master's thesis, King's College London, London, England, 2016.
- Matheny, J. G., Reducing the risk of human extinction, *Risk analysis*, 27(5), 1335–1344, wiley Online Library, 2007.
- Möller, P., R. Loewens, I. Abramov, and E. Albats, Eva suit 2000: A joint european/russian space suit design, *Acta astronautica*, 36(1), 53–63, 1995.
- NASA, About analog missions, <https://www.nasa.gov/analogs/what-are-analog-missions>, 2016.
- Newman, D. J., Life in extreme environments: How will humans perform on Mars?, *Gravitational and Space Research*, 13(2), 2007.
- Oberth, H., *Ways to spaceflight*, 622, National Aeronautics and Space Administration, 1972.
- O'Connell, M. K., H. G. Slade, and R. G. Stinson, Advanced spacesuit portable life support system packaging concept mock-up design & development, *Tech. rep.*, SAE Technical Paper, 1999.
- Ordway, F. I., R. Liebermann, and B. Bova, *BLUEPRINT FOR SPACE PB*, Smithsonian, 1992.
- Reid, C. R., L. R. Harvill, J. R. Norcross, E. A. Benson, S. A. England, K. Young, and S. L. Rajulu, An ergonomic evaluation of the extravehicular mobility unit (emu) spacesuit hard upper torso (hut) size effect on mobility, strength, and metabolic performance, in *Proceedings of the Human Factors and Ergonomics Society Annual Meeting*, vol. 58, pp. 1595–1599, SAGE Publications Sage CA: Los Angeles, CA, 2014.
- Ross, A., R. Rhodes, D. Graziosi, B. Jones, R. Lee, B. Z. G. Haque, and J. W. Gillespie, Z-2 prototype space suit development, 44th International Conference on Environmental Systems, 2014.
- Severin, G. I., I. P. Abramov, V. I. Svetshek, and A. Y. Stoklitsky, Some results on modification of the eva suit for the mir orbiting station, *Tech. rep.*, SAE Technical Paper, 1995.

- Sipila, S., and N. Mary, Mars and extravehicular activity: A challenging synergy, *LPI Contributions*, 1791, 1420, 2014.
- Skoog, A. I., and I. P. Abramov, The soviet/russian spacesuit history: Part iii—the european connection, *Acta Astronautica*, 60(12), 1002–1014, 2007.
- Soucek, A., L. Ostkamp, and R. Paternesi, Suited versus unsuited analog astronaut performance using the aouda. x space suit simulator: the delta experiment of mars2013, *Astrobiology*, 15(4), 283–290, 2015.
- Thomas, K. S., Hard upper torso for rear entry suit, uS Patent App. 13/175,994, 2011.
- Webbon, B., B. Luna, J. Brown, A. Gonzales, H. Jones, B. Koss, and D. Smith, Innovative concepts for planetary eva access, *Tech. rep.*, SAE Technical Paper, 2007.
- Wikipedia, Hard upper torso, [https://en.wikipedia.org/wiki/Hard\\_Upper\\_Torso](https://en.wikipedia.org/wiki/Hard_Upper_Torso), 2015.