

**DECISION SUPPORT SYSTEM FOR MASONRY LABOR PLANNING AND
ALLOCATION CONSIDERING PRODUCTIVITY AND SOCIAL SUSTAINABILITY**

A Dissertation
Presented to
The Academic Faculty

By

Laura Florez

In Partial Fulfillment
Of the Requirements for the Degree
Doctor of Philosophy
In Building Construction

Georgia Institute of Technology

December, 2015

Copyright © 2015 by Laura Florez

**DECISION SUPPORT SYSTEM FOR MASONRY LABOR PLANNING AND
ALLOCATION CONSIDERING PRODUCTIVITY AND SOCIAL SUSTAINABILITY**

Dr. Daniel Castro-Lacouture, Advisor
School of Building Construction
Georgia Institute of Technology

Dr. Xinyi Song
School of Building Construction
Georgia Institute of Technology

Dr. Sonit Bafna
School of Architecture
Georgia Institute of Technology

Dr. Charles Rudolph
School of Architecture
Georgia Institute of Technology

Dr. Andres L. Medaglia
Industrial Engineering
Universidad de Los Andes

Maria Viteri, AIA, LEED B+C
International Masonry Institute

Date approved: June 18, 2015

ACKNOWLEDGEMENTS

I could not have accomplished this dissertation without the support of my parents and their unconditional love. The strong values you instilled in me have been very fruitful. I also want to thank my sister Tatiana, my brother-in-law Sebastian and my niece Mia for always believing in me; my sister Silvia and my brother-in-law Jean for their encouragement and for backing my research efforts. I have no words to express how much I love you. We did it!

I especially want to thank my advisor, Dr. Daniel Castro-Lacouture who supported me in this journey and always encouraged me to think positively. I also want to thank Dr. Andres L. Medaglia for his helpful recommendations; I am also grateful to Dr. Xinyi Song, Dr. Charles Rudolph and Dr. Sonit Bafna for their constructive remarks on my work.

I want to thank Maria Viteri and the International Masonry Institute for their warm welcoming to the National Training Center and collaboration with my research effort.

I am very grateful to the masonry contracting firms who facilitated the data collection and all the owners, superintendents, managers, masons, laborers, and field personnel from across the United States that participated in this research process. During the last two years I enjoyed great conversations and I am very happy to have learned tremendously from each one of you about this trade. I hope I made a contribution to the masonry industry and I hope to continue advancing this trade.

Finally, I want to thank all my friends and colleagues for making life happier.

DISCLAIMER: This dissertation is an independent study and is not part of any research project or research initiative.

TABLE OF CONTENTS

	Page
ACKNOWLEDGEMENTS	iii
LIST OF TABLES	vi
LIST OF FIGURES	vii
SUMMARY	x
CHAPTER 1: INTRODUCTION	1
1.1 Background	1
1.2 Motivation	3
1.3 Objectives	5
1.4 Contributions	7
1.5 Dissertation structure	
CHAPTER 2: LABOR IN CONSTRUCTION	9
2.1 Labor shortage	11
2.2 Characterizing construction labor	13
2.3 Labor impact on productivity	15
2.4 Masonry labor productivity	17
2.5 Labor management and allocation	19
2.6 Labor allocation models	23
2.7 Well-being of workers	25
2.8 Discussion chapter 2	27
CHAPTER 3: METHODOLOGY	28
3.1 Semi-structured interviews	29
3.2 Information from the interviews	33
3.3 Sample of interviewees	35
3.4 Discussion chapter 3	57
CHAPTER 4: CURRENT PRACTICE	58
4.1 Labor requirements	58
4.1.1 Summary of the results- Labor requirements	66
4.2 Rules for crew design	70
4.2.1 Summary of the results-Rules for crew design	90
4.3 Drivers for crew makeup	93
4.3.1 Summary of the results- Drivers for crew makeup	101

4.3.2 Proposed drivers	102
4.3.3 Wall degree of difficulty	104
4.4 Discussion chapter 4	105
CHAPTER 5: DECISION SUPPORT SYSTEM	110
5.1 Problem definition	113
5.2 Literature review	114
5.3 Masons functions	117
5.4 Model framework	118
5.5 Model formulation	120
5.6 Numerical example	123
5.7 Comments on the productivity score	133
5.8 Case study: scheduling a masonry project	135
5.9 Discussion chapter 5	150
CHAPTER 6: GENERAL DISCUSSION	152
6.1 Benefits and limitations	154
6.2 Future research	155
REFERENCES	161

LIST OF TABLES

Table 1	Interview protocol	37
Table 2	Roles	69
Table 3	Suitability score for masons	126
Table 4	Craft score for masons	127
Table 5	Compatibility score for masons	128
Table 6	Characteristics of wall 1	129
Table 7	Characteristics of wall 2	131
Table 8	Masons that belong to each possible crew formation	138
Table 9	Characteristics of the nine walls	141
Table 10	Compatibility score for masons (superintendent provided scores)	143
Table 11	Suitability score for masons	144
Table 12	Craft score for masons	144

LIST OF FIGURES

Figure 1	Task distributions for stage 1	22
Figure 2	Task distributions for stage 2	23
Figure 3	Area of operation of respondents (states colored in blue)	36
Figure 4	Superintendent on the site overseeing the installation of stone pieces	60
Figure 5	Foreman (right) giving instructions to the forklift operator	61
Figure 6a	Assistant foreman assigned to install a door frame	62
Figure 6b	Assistant foreman (left) laying out a wall with the chalk line	62
Figure 7	Labor foreman (middle) giving instructions to the forklift operator	63
Figure 8	Figure 8a- Mason laying block	63
Figure 8b	Mason laying brick	63
Figure 9a	Laborer stocking material next to a wall	65
Figure 9b	Laborer grouting a block wall	65
Figure 9c	Laborer making mortar in the mixer	65
Figure 9d	Laborer building scaffold	65
Figure 9e	Laborer operating the saw	65
Figure 9f	Forklift operator carrying material in the site	65
Figure 10	Mason working in an interior column	71
Figure 11	Crew of three masons and one laborer working on a brick veneer wall	73
Figure 12	A crew of two masons and one laborer working on a block wall	74
Figure 13	Foreman using the laser to lay out a wall	76
Figure 14	Wall ready for the masons	77
Figure 15	Three masons and two laborers working on a block wall	78
Figure 16	Mason cleaning the surface of the blocks and finishing joints	79

Figure 17	Three masons working on a block wall. One laborer tending	81
Figure 18	Crane used to lift a metallic cage with blocks	82
Figure 19	Long straight block wall with two masons (left) and one laborer	83
Figure 20	Mason and laborer working on a short block wall	84
Figure 21	Two laborers carrying block on a wheel barrel and stocking units	85
Figure 22	Scaffold to build a long straight wall	85
Figure 23	Hydraulic scaffold is used to build a brick veneer wall	86
Figure 24	Two masons working on a 24 ft. block wall	87
Figure 25	Two masons working on a 25 ft. long brick veneer wall (two left)	88
Figure 26	Four masons (and laborer) on an L-shaped block wall	89
Figure 27	Masons assigned repeatedly to work together in different wall sections	94
Figure 28	Mason measuring and marking the cuts for an electric box	96
Figure 29	String line used to lay masonry units	97
Figure 30a	Mason using the level to build a block wall	97
Figure 30b	Mason working on a wall with numerous windows	97
Figure 31	Mason working on a long straight block wall	98
Figure 32a	Mason working on a high quality brick veneer wall	99
Figure 32b	High quality wall with insertions and color brick	99
Figure 33	Masons putting the pole line in a brick veneer wall	100
Figure 34	Mason building the lead in a block wall	101
Figure 35	Easy/normal wall	106
Figure 36	Easy/Normal wall	106
Figure 37	Easy/normal wall	107
Figure 38	Difficult wall	108
Figure 39	Difficult wall	109
Figure 40	Labor allocation for one week	112

Figure 41	Model framework	119
Figure 42	Information for wall 1	124
Figure 43	Information for wall 2	125
Figure 44	East façade of the building and haracteristics of the the brick	137
Figure 45	North façade of the building	139
Figure 46	Precedence relations between the walls	140
Figure 47	Report per mason (case study)	145
Figure 48	Report per crew (case study)	145
Figure 49	Schedule for the walls (case study)	146
Figure 50	Schedule for the walls (model)	147
Figure 51	Report per mason (model)	147
Figure 52	Report per crew (model)	148
Figure 53	Schedule for the walls (model)	149
Figure 54	Schedule for the walls (case study)	150
Figure 55	Team and job performance study approach	157

SUMMARY

Masonry construction is labor-intensive. Processes involve little to no mechanization and require a large number of crews made up of workers with diverse skills, capabilities, and personalities. Relationships among crews are tight and very dependent. Often crews are re-assembled and the superintendent is responsible for assigning workers to crews and allocating crews to different tasks to maximize workflow. This dynamic environment can influence the motivation of workers and impose pressure and stress on them.

Workers, unlike other resources, have their own needs and requirements beyond the financial compensation for their work. Workers place a great value on requirements such as certainty about work assignments, matching assignments to career development goals, and work satisfaction. If managed properly, workers may bring considerable benefits to both the project and the contractor. A project that links workers to career goals not only allows contractors to develop more qualified staff for its future projects, but also gives the worker opportunities for career growth and development. Additionally, job satisfaction and efficiency increases from suitable worker assignment and consideration of tasks. Therefore, the study of sustainable labor management practices is of interest in masonry construction and other labor-intensive industries.

A mixed-integer programming (MIP) model enables the integration of workers needs and contractor requirements into the process of labor allocation. Furthermore, the model can be used to quantify strategies that maximize productivity, quality of work, and the well-being of workers. Developing such a model is a necessary task. To plan and manage masonry construction, the contractor has to take into account not only multiple workers with different characteristics but also rules for crew design and makeup and project requirements in terms of personnel needs. Providing an analytical description of all the needs and requirements is challenging. Therefore, to determine labor

management practices that indeed maximize production and maximize workers satisfaction, the model needs to realistically represent the realities in masonry construction sites and staffing practices, while remaining computationally manageable such that optimization models can be derived.

This dissertation proposes a decision support system (DSS) for sustainable labor management in masonry construction that takes into consideration information on workers and job characteristics with the intention of assisting decision makers in allocating crews. Firstly, semi-structured interviews were conducted with masonry practitioners to gather perspectives on labor requirements, rules for crew design, and drivers for crew makeup. Secondly, a model that incorporates realities was implemented. The model supports masonry contractors and superintendent in the challenging process of managing crews, that is, to determine the composition of each crew and the allocation of crews to maximize productivity and workflow while considering workers' preferences and well-being. With the DSS, project managers and superintendents are not only able to identify working patterns for each of the workers but also optimal crew formation and investment and labor costs. Data from real case study is used to compare the schedule and allocation on the site with the one proposed by the model. The comparison shows the model can optimize the allocation of crews to reduce the completion time to build the walls while maximizing the utilization of masons and outlining opportunities for concurrent work. It is expected that the DSS will help contractors improve productivity and quality while efficiently managing masonry workers in a more sustainable way.

The contributions for the masonry industry are two-fold. Firstly, the proposed model considers a set of rules that masonry practitioners typically use to design crews of masons and analytically captures the realities of masonry construction jobsites when managing labor. Secondly, it attempts to quantify and mathematically model the practices that contractors use for crew makeup and evaluate labor management

allocation both in terms of contractor requirements and worker needs. Literature review indicates that the existing models for labor allocation have not taken into consideration masonry site realities.

An optimization framework, which combines masonry site realities from the semi-structured interviews is proposed. The framework results in a MIP model that is used to solve a crew scheduling and allocation problem. The model is formulated to determine which masons are in a crew and to assign crews to the different walls in a project. Additionally, it is used to evaluate crew design strategies that maximize productivity.

Keywords: masonry construction, optimization, labor management, crew allocation, social sustainability

CHAPTER 1

INTRODUCTION

1.1 Background

Project-oriented organizations such as construction companies use temporary organizations to complete work demand (Huemann et al, 2007; Brucker et al, 2011). Construction projects not only are unique but are also limited in time and scope. Therefore, every time a new project starts the crew configuration and allocation of workers change (Turner et al, 2008). This creates a dynamic and transient work environment frequently seen in masonry construction projects. In masonry, workers are transferred between different projects and even between different roles to accomplish a specific task. This temporary nature of the work influences the motivation of workers and creates pressure due to the uncertainty of work assignments, work durations, and lack of opportunities for career growth (Turner et al, 2008; Loosemore et al, 2003; Lingard and Sublet, 2002). Additionally, the number and function of workers needed in every project change constantly, making it difficult for contractors to determine the optimal crew formation and for workers to achieve a work-life balance and work satisfaction.

Masonry contractors divide work into different wall sections and usually work with crews (Ng and Tang, 2010) to build walls in a project. Crews work in walls that are available (e.g. there is no other craftsman working in the wall) and accessible (e.g. the concrete structure has already been poured). Crews also work in areas where the plumbing, ductwork, and electric conduits are already installed and in areas where openings and sheathing walls are marked and already placed so that masons can lay units around.

Due to the varying conditions in a masonry site, there are different types of walls, with each wall having special features. For instance, some walls are very long and straight and do not have openings, while others are short and have numerous openings that require very detailed work. Some walls are made of smaller units such as brick that do not have reinforcement bars while others are made of larger units such as block that have reinforcement bars and need grouting. Because walls have different features, masonry sites require diverse workers to build those walls.

The activities in a masonry project, such as laying units, mixing mortar, cutting units, grouting, scaffold building, and erection, are labor-intensive and require a large number of workers that are extremely heterogeneous. Crews are configured by the contractor, provided that the workers of each crew possess the skills needed for each of the tasks to complete the walls. Often when a wall section is completed, crews are re-assembled and the contractor is responsible for assigning workers to the crews and allocating crews to the different tasks. Due to this task division, multiple crews are present on the jobsite at any one time and the contractor has to constantly assemble crews and properly sequence their work to maximize workflow.

A decision support system (DSS) that integrates all the characteristics of the workers can enable masonry contractors to optimally assign the most suitable workers to the various walls across the projects. This DSS can bring significant benefits to both contractors and workers. Firstly, contractors can maximize workflow and production by assigning the most suitable workers to the different tasks based on the various characteristics of the workers, the properties of the walls, and the conditions of the site. Secondly, workers will maximize their well-being as long as their needs of work, collegiality, work satisfaction, and career development are taken into account.

1.2 Motivation

According to the latest statistics published by the U.S. Bureau of Labor Statistics (BLS), eight construction occupations have the fastest employment growth for the years 2012 to 2022 (BLS, 2014). The recent BLS data indicates that the projected rate of change for the 10-year timeframe for these occupations is much higher compared to the average growth rate of all occupations (14%). Included in the list of occupations in construction with the fastest growth are: stonemasons, brick masons, and block masons (34%); cement masons and terrazzo workers (29%); and helpers-brick masons, block masons, and stonemasons (25%) among others. Given this projected growth, there is a need for skilled workers and new entrants to satisfy this demand. However, the construction industry is not a very attractive working environment due to the transient nature of the work and the uncertain career paths for its workers (Gomar et al, 2002; Srour et al, 2006). Within the crafts in construction, masonry is considered a demanding craft. Masons and helpers (laborers) work outdoors and are subject to poor weather conditions that may reduce their work activity (BLS, 2014). Furthermore, work is physically demanding and masons as well as mason helpers often lift heavy materials and stand for long periods of time (Boschman, 2011). By considering masonry workers needs and expectations, projects may not only benefit current workers but may also help attract new masons and laborers to fill these positions.

Workers, unlike other resources, have their own needs and requirements beyond the financial compensation for their work. Workers place a great value on requirements such as certainty about work assignments, matching assignments to career development objectives, and sense of personal growth.

Because of their needs and requirements, workers may represent the most difficult resource for organizations to manage but, when managed effectively, can bring considerable benefits (Loosemore et al, 2003). For instance, a project that links project assignments to career development not only allows contractors to develop staff for its future projects but also helps workers develop skills and opportunities for career growth (Lingard & Sublet, 2002). At the same time, contractors benefit through increased work control by better using education and competence development that increases job satisfaction and motivation (Turner et al, 2008). Projects have better productivity rates where employee work experience is enhanced by assembling teams that consider managers and co-workers as well as tasks and roles (Turner et al, 2008). Moreover, projects receive greater loyalty from their workers and better productivity where conditions are set to provide more equitable workplace environments (Loosemore et al, 2003). By considering their needs and expectations, construction projects may not only benefit current workers but may also help attract other workers to the field.

1.3 Objectives

The main objective of this work is to develop a DSS that helps superintendents and masonry contractors manage labor so as to maximize productivity while considering workers' preferences and well-being. Within this context the objectives are:

1. To explore the rules for crew design and makeup. This involves gathering perspectives and knowledge from industry stakeholders. Furthermore, this objective encompasses identifying staffing processes and understanding labor planning and allocation in masonry construction sites.
2. To determine intrinsic characteristics of workers and how these characteristics relate to site conditions that may impact labor management in masonry

construction. Furthermore, how to consider these characteristics in planning and staffing projects to increase productivity and workers' well-being and satisfaction.

3. To propose a model that performs allocation and scheduling of crews in masonry construction projects and to use it to evaluate labor productivity increase strategies. This requires a model that is sufficiently detailed, such that the strategies to increase productivity at the program management level can be evaluated.
4. To compare the model's allocation and schedule against a real case study and determine whether there are potential time savings by considering in advance different crew configurations, mason underutilization, and productivity increases.

1.4 Contributions

A summary of the main contributions of this dissertation follows.

Current practices:

- This dissertation gathers perspectives and explores labor management practices of masonry stakeholders and practitioners across the United States. Through semi-structured interviews, knowledge is gathered about the type and characteristics of workers, roles, and activities in masonry sites. Furthermore, the interviews provide detailed descriptions of the rules practitioners use for crew design that directly impact labor needs and the size of crews in masonry sites.
- Staffing processes and labor planning are also investigated to understand the criteria used by practitioners in the makeup of crews. It openly examines the guidelines that are currently used to form efficient and productive crews.

Optimization Model:

- To address the crew allocation problem, one model to assign crews to the different walls is presented. As described, the main challenge is to incorporate realities, that is, to identify how the characteristics of workers are related to different conditions on the site so that the most suitable workers are assigned to the walls that require those characteristics.

For this model, the formulation is provided and then integrated within an optimization framework to perform workers allocation. The results for the model quantifies labor needs and evaluates formation strategies to determine the most efficient and productive crews considering their well-being or social sustainability.

Decision support system (DSS):

- The proposed decision support system includes typical contractors requirements to address realistic scenarios experienced by masonry contractors in the jobsite. In addition, the model considers the workers' needs such as worker preferences and job satisfaction.
- The crew allocation process in masonry construction is challenging. Masonry is labor-intensive, and often crews have to be re-assembled to complete walls. Multiple crews with different skills, capabilities, and personalities are present on the jobsite at any one time, and it is difficult to determine which crew should be assigned to which wall and when each crew should be working. Consequently, contractors need to plan the work of the crews as well as the appropriate sequencing of tasks to maximize productivity.
- A case study of a masonry construction project will be implemented to evaluate and predict if efficiencies in mason allocation can be accomplished while meeting

crew design and makeup considerations. It is expected that the decision support system will support labor planning in masonry projects.

- The proposed decision support system integrates an exploratory approach and a modelling approach in an attempt to understand the challenges in masonry construction jobsites and to develop a tool that can help alleviate some of the issues faced by masonry decision-makers in their day-to-day practices. The exploratory approach helps to understand current practices in masonry that affect the size of the crews while considering productivity and social sustainability. The modeling approach will form crews and allocate crews to the different walls.

1.5. Dissertation structure

Chapter 2 includes a literature review of labor management practices in construction.

Chapter 3 presents the methodology that is used to gather knowledge about current labor management practices in masonry.

Chapter 4 describes the state of practice in masonry construction. It presents the labor requirements, the rules for crew design and the drivers for crew makeup that are used by masonry practitioners. Preliminary results of the state of practice have been published in the peer-reviewed papers below. However this dissertation includes new results.

- Florez, L. & Castro-Lacouture, D. (2015). Modelling and quantifying design rules for masonry construction crews. *Proceedings of the 12th North American Masonry Conference*, Denver, CO, USA, May 17-20.

- Florez, L. & Castro-Lacouture, D. (2014). Optimal crew design for masonry construction projects considering contractor's requirements and workers' needs. *Proceedings of the 2014 ASCE Construction Research Congress*, Atlanta, GA, USA, May 19-21.

Chapter 5 presents the decision support system for sustainable labor management for masonry construction. Preliminary results of incorporating social sustainable practices when managing labor in construction have been published in the peer-reviewed papers below. However this dissertation includes new results

- Florez, L., Castro-Lacouture, D., & Medaglia, A.L. (2013). Sustainable workforce scheduling in construction program management. *Journal of the Operational Research Society*, 64(8), 1169-1181.
- Florez, L., Castro-Lacouture, D., & Medaglia, A.L. (2012). Maximizing labor stability as a sustainability performance indicator in project scheduling. *Proceedings of the 2012 ASCE Construction Research Congress*, West Lafayette, IN, USA, May 20-22.
- Florez, L., Castro-Lacouture, D., & Medaglia, A.L. (2011). Program management optimization model using sustainability performance indicators. *Operational Research Society OR53 Conference*, Nottingham, UK, September 6-8.

Chapter 6 presents conclusions and future lines of research that have arisen from the results of this dissertation.

Chapter 7 presents the references

CHAPTER 2

LABOR IN CONSTRUCTION

It is estimated that the US construction industry currently employs 13.9% of the total workforce, which is about 5,088,030 workers (BLS, 2014). The recent Bureau of Labor Statistics (BLS) data indicates that eight construction occupations have the fastest employment growth for the years 2012 to 2022 (BLS, 2014). As stated by the BLS, the projected rate of change for the 10-year timeframe for these occupations is much higher compared to the average growth rate of all occupations (14%). Included in the list of occupations in construction with the fastest growth are: stonemasons, brick masons and block masons (34%), cement masons and terrazzo workers (29%), and helpers-brick masons, block masons, stonemasons (25%) among others. Masonry construction employs about 58,730 brick masons and block masons, stone masons (10,410), tile and marble setters (30,090), terrazzo workers and finishers (3,220), and helpers-brick masons, block masons, stonemasons, and tile and marble setters (24,280) (BLS, 2014). Current data shows that the employment in construction has continued to trend up, adding approximately 12,000 more jobs. Given this projected growth, there is a need for qualified workers and new entrants to satisfy this demand (Levanon et al, 2014). However, it is recognized that the construction industry is not a very attractive working environment due to the transient nature of the work and the uncertain career paths for its workers (Gomar et al, 2002; Srour et al, 2006).

The skilled craft shortage is one of the issues that the construction industry faces today (Wang et al 2009, AGCA 2014, Levanon et al, 2014). The Business Roundtable in the early 1980s predicted that a shortage of skilled workers would impact the growth of both open shop companies and union construction sectors (Business Roundtable, 1993).

This was later confirmed by a study in 1996 that found that 60% of the members it surveyed experienced a shortage of skilled craft workers. The shortage seems to have increased in more recent years. The Construction Users Roundtable (CURT) conducted a survey in 2001 in which 85% of the respondents determined a shortage in their projects. Out of these respondents, 78% indicated that the shortage had worsened in the 3 years prior to the study (CURT, 2001) and in 2007 it was about 86% (Sawyer and Rubin 2007). The Construction Labor Research Council predicted in 2009 that the construction industry needed to attract, train, and retain 185,000 new workers each year up to 2016 in order for the industry to replace the expected turnover of craft workers throughout the industry and also sustain the expected growth.

These results are not different from the results reported by Levanon et al (2014) and the Associated General Contractors of America (AGCA). In 2013 the AGCA surveyed construction firms and 74% of firms reported having a hard time finding qualified craft workers while 53% reported having difficulty filling professional positions (AGCA, 2014). Note that craft workers include professional carpenters, equipment operators, plumbers, and laborers among others. Professional staff refers to executives, managers, office professionals, and field supervisors among others. In 2014 the AGCA again surveyed construction firms. What is clear from the results is that the shortage of workers, particularly of craft workers, is becoming more severe. This makes job growth inconsistent, which certainly impacts construction employment. According to the latest results dated 2014, employment in construction increased in 37 states and 28 states added jobs between 2013 and 2014 but the growth continues to be vulnerable to workers shortages and new regulatory burdens. From the construction firms surveyed in 2014, 83% reported having trouble finding qualified workers to meet growing demand of construction services, while 53% reported having difficulty filling professional positions (AGCA, 2014).

2.1 Labor shortage in construction

There are some specific factors that have contributed to the shortage of craft workers in the construction industry. Firstly, the construction industry is not a very attractive working environment due to the transient nature of the work and the uncertain career paths for its workers (Gomar et al, 2002; Srour et al, 2006). Despite the fact that construction has improved compensation levels (AGCA, 2014), many firms continue to lose qualified workers to other employers. Companies have difficulties maintaining and recruiting workers because companies usually focus on cost considerations and workers have other requirements beyond the financial compensation of their work. Workers place a great value on requirements such as involvement, respect, and sense of personal growth (Lingard and Sublet, 2002) and when these requirements are met they can bring considerable benefits. For instance, a project that offers continual employment allows contractors to not only use workers more efficiently and at lesser cost, but also helps generate a sense of commitment to the job from the workers (MacKenzie et al, 2010). At the same time, an increase in employment duration may help train workers and resolve the skills shortage problem within the construction industry (Gomar et al, 2002; Srour et al, 2006; MacKenzie et al, 2010; Levanon et al, 2014). Projects receive greater loyalty from their workers and better productivity where conditions are set to provide improved career opportunities and more equitable workplace environments (Loosemore et al, 2003). Furthermore, career growth is directly related to the degree of education, which positively impacts on the flexibility of the workforce and its adaptability to unforeseen activities (Srour et al 2006; AGCA, 2014). A more educated workforce may have the necessary knowledge for adopting more technical production techniques which may translate into higher levels of productivity and quality of work (Loosemore et al, 2003).

Secondly, the use of single skilled workers or workers that can only be able to perform in one trade is a limiting factor for labor efficiency (Wang et al, 2009). Alternative training strategies towards developing quality programs that provide adequate training for craft workers could not only benefit workers but also could benefit contractors and owners. Extensive research has been conducted in construction regarding the benefits of multiskilling (Burlison, 1998; Gomar et al, 2002; Thomas and Harman, 2006; Lill, 2008; Florez et al, 2013). Benefits have been observed with regard to employment opportunities for construction workers. Multiskilling is a labor strategy that has proven successful to help workers stay longer on a project. According to a study conducted by the Construction Industry Institute (CII) at the University of Texas at Austin, one of the benefits of utilizing a multi-skilled workforce is a potential 47% increase in average employment duration. Burlison et al (1998) reported a workforce reduction of 35% in projects that used multi-skilled workers. The reduction of workers, they concluded, showed a greater appeal to potential workers because of the development of career type employments and skill enhancement opportunities. Gomar et al (2002) concluded that multi-skilled workers have continuity of job assignments, longer employment durations, and increased employability. Lill (2008) indicated that multi-skilled workers have a broader variety of skills which makes them adaptable to unforeseen activities and allows the manager more flexible utilization of their capacities. Thomas and Hartman (2006) cited multiskilling as a fundamental principle of workforce management, that is, a strategy that project managers should use to efficiently manage crews in construction.

Benefits have also been observed with regard to cost savings and productivity. According to the study developed by the CII, the benefits of utilizing a multi-skilled workforce include total labor cost savings of 5% and productivity improvements by over 75%. Burlison et al (1998) found between 5% to 20% reductions in labor costs from 5% to 20%.

Cross (1996) stated that multi-skilling brings not only costs but also productivity benefits. Most recently, Liu and Wang (2012) have stated that by incorporating multi-skilled crews, there is an opportunity towards improving work productivity with repetitions. Florez et al (2013) have reported multiskilling as a strategy that provides labor stability for workers.

Thirdly, the construction industry does not have specific information on its workforce compared to other industries such as the manufacturing and services industries (McFillen and Maloney, 1986). Unlike the services and manufacturing industries that have a more stable workforce, labor fluctuation is very common in the construction industry, which limits the possibility of collecting information on the nature of its workforce. Workers usually identify themselves with their trade or union rather than with a given employer hence companies and construction associations have made little effort to develop detailed information on the workforce (McFillen and Maloney, 1986). In other words, information about the skills and capabilities of its workers. The collection of this information would have major implications for labor management in the construction industry. Detailed information would help the construction industry to not only plan for future labor demand but also to optimize the utilization of the available workers and get the best out of the workers (McFillen and Maloney, 1986; Rowings et al, 1996). Specifically, information on intrinsic characteristics of masons, how these characteristics influence the interaction between masons, and how these characteristics relate to site conditions that may impact workflow.

2.2 Characterizing construction labor

A number of studies have attempted to characterize labor in construction, that is, detail and describe the characteristics or features of workers.

McFillen and Maloney (1986) conducted a study with unionized construction workers to collect data on education, training, experience, employment history, and a variety of demographic variables. Data showed that younger workers were not joining unions in the same numbers as in the past and there was going to be a shortage of skilled workers, which had implications for productivity and on the funded benefits for the existing workers. The study discussed the need for improved human resource planning and management in the construction industry. Rowings et al (1996) developed a model to get an insight into how craft workers perceive job satisfaction and satisfaction with the financial aspects of construction work. Through a survey questionnaire administered to 4,600 respondents, workers were asked about the perceptions of their job, career, and employment conditions. In terms of job satisfaction, the study showed that higher ranked workers, women, and workers who had received training were more satisfied than their counterparts. Furthermore, compensation levels and construction as a career option were directly influenced by the age of the workers. The study highlighted the importance of knowing the perceptions of workers by management personnel to get the best out of the workers, retain skills that currently exist, and build a strong and competitive future workforce.

Srouf et al (2006) developed a research effort to characterize the US construction workforce. It presented the social and demographic attributes of a sample of 862 workers and then further discussed the attributes that the construction industry values the most, based on the hourly wages and average incomes. Results revealed the importance of years of experience and computer knowledge, which are reflected in higher wages. As reported by Srouf et al (2006) workers who know how to operate computers made higher salaries than workers who do not possess computer knowledge. In terms of years of experience, results showed that at the journeyman level and foreman level one more year of experience was reflected in higher hourly wages (Srouf

et al 2006). Previous research has analyzed the characterization in construction labor in other contexts such as Jayawardane and Gunawardena (2010), Muya et al (2006), and El-Dash (2007). These studies have identified demographic characteristics of workers and factors that workers consider as relevant to their development and career growth.

2.3 Labor impact on productivity

Other studies have focused on labor factors that affect workflow and productivity. Maloney and McFillen (1987) examined construction workers perceptions of work-crew functioning and explored the impact of that functioning upon worker motivation and performance. Through a survey questionnaire administered to 703 union workers, the study identified five elements of crew-work functioning: effectiveness, openness, cohesion, goal clarity, and goal difficulty. The study found that crews may have a significant influence on worker motivation, performance, and satisfaction. The study also found that improved work-crew functioning could be achieved by designing cohesive crews and making workers more comfortable with each other. As concluded and suggested by Maloney and McFillen (1987), contractors need to give time and attention to crew staffing and team building since these two approaches have been shown to improve performance of workers and crews.

Olomolaiye et al (1998) investigated the factors affecting productivity from the perspective of a group of bricklayers in the UK. Lack of materials was identified as the most significant factor affecting productivity followed by crew interference, rework, supervision delay, lack of equipment/tools and absenteeism. Dai et al (2007) conducted a study to determine the factors that influence productivity from the perspective of both craft workers and foremen in the US. Through a survey questionnaire administered to 1,996 respondents, workers were asked about the perceptions of their job, career, and employment conditions.

Major findings indicated that craft workers and foremen tend to have similar opinions on factors that affect productivity such as equipment, communication, supervision, and materials. Foremen reported project management and engineering drawings to have more impact on productivity whereas craft workers reported construction materials to have a more severe impact. Kaming et al (1997) conducted an investigation of the problems that influence craftsmen's productivity in Indonesia. Through a survey questionnaire administered to 243 workers and an activity sampling survey, workers were asked about the main factors that affect productivity. Major findings indicated that craft workers spend on average 75% of the time working productively although five specific problems affected productivity including lack of materials, rework, absenteeism, lack of equipment and tools, and interference due to improper sequence of work and crew size. As concluded and suggested by Kaming et al (1997), contractors need to give time and attention to proper worker's management practices. Hewage and Ruwanpura (2006) investigated human, management, and external issues affecting worker efficiency, productivity, and motivation in Canada. Human issues were investigated through a combination of interviews, observations, and a survey questionnaire administered to a group of 101 carpentry workers. The most highlighted areas for productivity improvement included time frame availability, group feelings, working conditions, effort to performance expectancy and non-existence of other sources of income. Smithers et al (2000) studied the effect of the workplace environment in the motivation of employees in Australia. The findings of the study showed that workplace factors such as long hours, chaos, non-recognition for work done, and colleague's aggressive management style negatively influenced the motivation of workers. Results revealed the importance of creating a more attractive workplace environment for workers and professional site staff to increase productivity.

2.4 Masonry labor productivity

There have been numerous studies in masonry construction to determine and quantify the factors that affect labor productivity. Determining and quantifying these factors are needed for estimating, planning, scheduling, and evaluating performance among others (Han and Lee, 2008). Sanders et al (1991) conducted a study to quantify and determine project-related factors affecting labor productivity in masonry. Through an exploratory analysis, it was determined that work type, building element, construction methods, design requirements, and weather are the most relevant factors affecting productivity. Further analyses indicated that repetitive designs help improve productivity by 30% whereas designs that require extensive cutting and layout can negatively affect productivity by 40%. Sanders and Thomas (1993) developed a model to forecast masonry productivity by considering the effects of project-related factors that change daily and may affect the overall measurement. A statistical model was developed to forecast the productivity of masonry activities based on data collected from 11 projects. Independent factors in the regression model included work type, building element, design requirements, construction methods, weather, and crew size to explain the expected productivity. The model was validated and tested by predicting the productivity of the projects, with 7 projects predicted within the 10% level. The model can be used to determine labor needs and to better plan and manage the projects as they progress. Anand and Ramamurthy (2003) determined the factors that affect productivity of alternative masonry systems. To measure the utilization of direct, indirect and non-contributory time by crew members, work sampling was used to compare the relative productivity of conventional and interlocking-block masonry. It was observed a productivity enhancement of 80-120% for dry-stacked masonry and 60-90% for bedded-interlocking block and thin-jointed masonry compared to that of conventional block.

Sweis et al (2008) quantified the factors that cause changes in productivity baseline measurements and conducted a comparative study of masonry labor productivity among the United States, United Kingdom, and Jordan. Results from the comparative study showed that changes in the baseline are caused mainly by workers skills, work methods, and especially the workers that are assigned to material handling. Sweis et al (2009) developed a method to model the variability of masonry labor productivity and to assess productivity loss in masonry construction. Fourteen projects sharing similar conditions and sociological factors were selected and measurements at the task-level work accomplished by a single crew in one shift were conducted. Documentation of the factor that could impact crew productivity was also performed. It was determined that congestion, sequencing, weather, supervision, information, equipment and tools, material and rework are the most relevant factors influencing productivity. Shen et al (2011) developed a study to compare productivity of masonry activities and operations between China and the United States. The study examined labor productivity measured by physical quantity installed per labor-hour based upon national average productivity data. Statistical analyses showed that there is a strong correlation between the productivity differences and labor usage. As indicated by the results, China's crew productivity lags behind its US counterpart mainly in equipment intensive construction where it was found that the first has a high labor intensive factor. On the contrary, the productivity for China and US crews was very similar for labor-intensive activities. Gerek et al (2015) modeled masonry crew productivity to compare the performance of the feed forward neural network and the radial basis neural network. A number of input factors with different combinations were incorporated in the models, which showed that neural techniques can be used to model crew productivity. Results also showed that the radial basis neural network was found to be better than the feed forward neural network.

As observed from previous studies, measuring labor productivity in masonry construction it's a great challenge. There are a variety of issues that give rise to this challenge and disagreement in addition to the difficulty of defining and quantifying productivity. The complexity of the construction environment itself and the fact that there are many different workers with different skills involved in each project, the significant variation in terms of the size of masonry construction projects, and also the different type of methods that have been used for productivity measurement have all made productivity metrics definition for the masonry construction industry a challenging task. As a result, efforts and research in terms of improving productivity measurements have remained an ongoing task as seen from above. However, there is no study on the influence on productivity of interaction terms, that is, the relation between masons and between masons and site characteristics.

2.5 Labor management and allocation

One of the most difficult problems a company faces is how to plan its workforce (De Bruecker et al, 2015). Defining when and how many workers should be hired or laid and when these workers should work make workforce planning a challenging task. Workers, unlike other resources, have many distinct and special characteristics that make the decision environment dynamic and managers have to deal with a very heterogeneous set of workers (De Bruecker et al, 2015). When workers are involved, companies not only must take into account labor needs and requirements but also workers characteristics.

Labor management processes and practices in a construction company are project-oriented as opposed to the traditional management practices that are product and service related and where job and task requirements are well defined and stable (Turner et al, 2008).

Considering labor requirements and effectively allocating the workers make labor planning crucial for the success of a construction project for the owner and the contractor (Jaskowski and Sobotka, 2006). Management of labor is a critical task in construction project management as labor costs on a project may account for about 30-50% of the total project costs (Harmon & Cole 2006). Labor management also indirectly affects the total project cost because it controls the productivity of equipment and materials that make up for the other direct costs (El-Dash, 2007). Labor management not only contributes to the success of a project, but also creates a competitive advantage for an organization (Shahhosseini and Sebt, 2011).

Masonry contractors usually manage a program of different project types that are unique, custom-made, and temporary. These features add uncertainty and novelty as no project is completed using the same approach. Consequently, contractors need to work in a cross-functional way and integrate resources (labor, equipment, and capital) in such a way so that they realize the maximum benefit for the operations. By integrating resources, contractors align resources to achieve the desired quality within the given time frame (Shehu & Akintoye, 2010).

Masonry construction is labor-intensive. Processes involve little to no mechanization and require a large number of crews made up of workers with diverse skills, capabilities, and personalities. In masonry construction, management of labor is one of the key factors to balance production and quality. Human resource allocation in masonry is the process of assigning crews of workers to tasks (Lin, 2011). Tasks may require several crews with diverse skills to be completed and crews need to be scheduled to ensure an efficient output and adequate control (Hassanein & Melin, 1997). This allocation process in masonry construction is challenging. Often times, crews complete their work on a section, but then have to be relocated to complete another part of a section.

Due to this characteristic, every time a wall section or part of a wall section is completed, the labor configuration is reorganized. This results in temporary crews that need to be constantly moving and the superintendent is responsible of reorganizing the crews to make sure the masons selected to build the walls have the required characteristics to produce good quality work. Human allocation deals with designing and configuring crews to assure workers have the functions required by the projects to complete tasks. The conditions of the site, and the workers' characteristics needed to complete the work within the given time and quality constraints. Effectively allocating the workers based on workers functions and characteristics make labor planning crucial for the success of a construction project for the owner and the contractor.

Figure 1 shows the common allocation of masons in a masonry site. Let's assume the site has 4 sections of block walls denoted as section 1, section 2, section 3, and section 4. In addition, lets assume section 1 and section 2 are ready for the masons to work in stage 1 while section 3 and section 4 are not ready and will be completed in stage 2. Note that wall sections have different characteristics such as geometry and number of openings and intricate work. Therefore the superintendent or foreman has to determine from the masons that are available, which masons will work in section 1 and section 2. From his experience and looking at the drawings and specifications of the walls, the superintendent or foreman has determined section 1 requires 1 mason and section 2 requires 4 masons. Therefore, the superintendent needs to determine from the five masons available, which mason is going to work in wall section 1 and which four masons are going to work in section 2. Section 1 is a short straight wall that has no openings or details and it is just a long wall or a line while section 2 is a much bigger section which is a difficult wall that has a few openings and details. Once stage 1 starts as shown in Figure 1, a crew of one mason needs to be working in wall section 1 and a second crew of four masons needs to be working in wall section 2.

In this study, the term crew refers to the group of masons that are working in a wall section. That is, a project may have multiple crews working in different wall sections.

Let's assume section 1 and section 2 are completed in stage 1. After wall section 1 and section 2 are completed the masons need to be allocated to section 3 and section 4 that are ready in stage 2. Therefore, the superintendent is responsible of configuring and assigning new crews to work during stage 2.

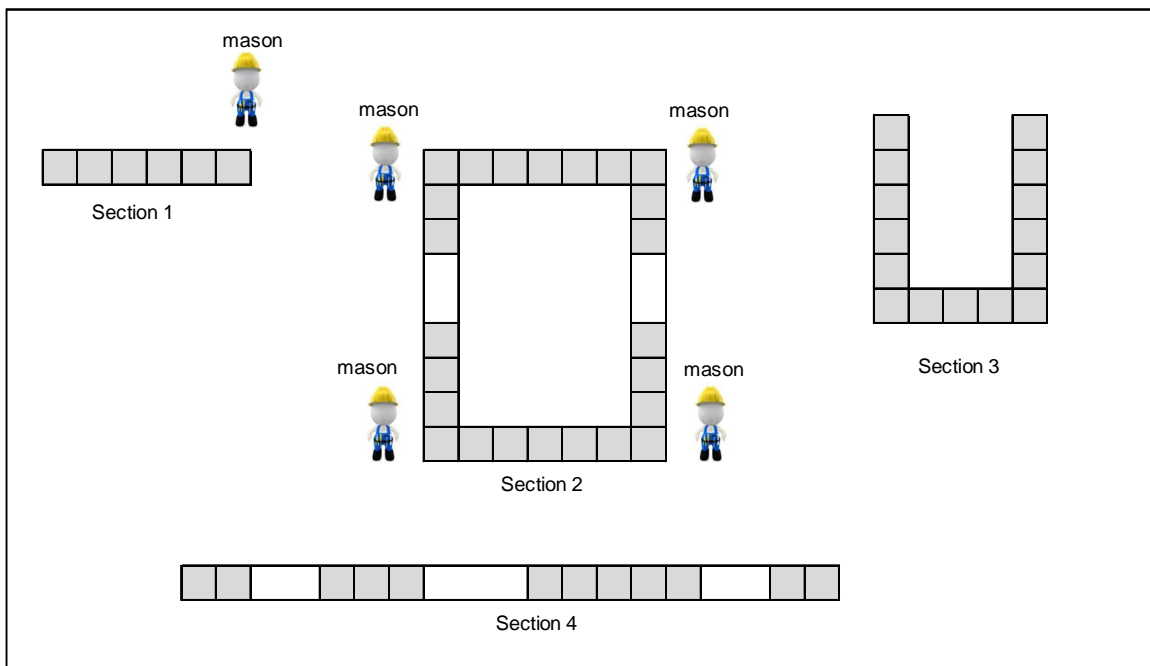

Figure 1- Task distributions for stage 1

In stage 2 (as shown in Figure 2), a crew of two masons is needed to work in wall section 3, which can be an elevator shaft or stairwell. A second crew of three masons needs to be working in wall section 4 which is a straight wall with openings. This wall may have some window and door jams. Note that for each wall section in the site the labor requirements might change.

Therefore, the superintendent needs to determine from the 5 masons available, which two masons will go to work in section 3 in the elevator shaft and which 2 masons will go to work to section 4 which is a straight line. In other words, the superintendent needs to properly allocate the masons to the wall sections based on the characteristics of the masons and the characteristics of the walls.

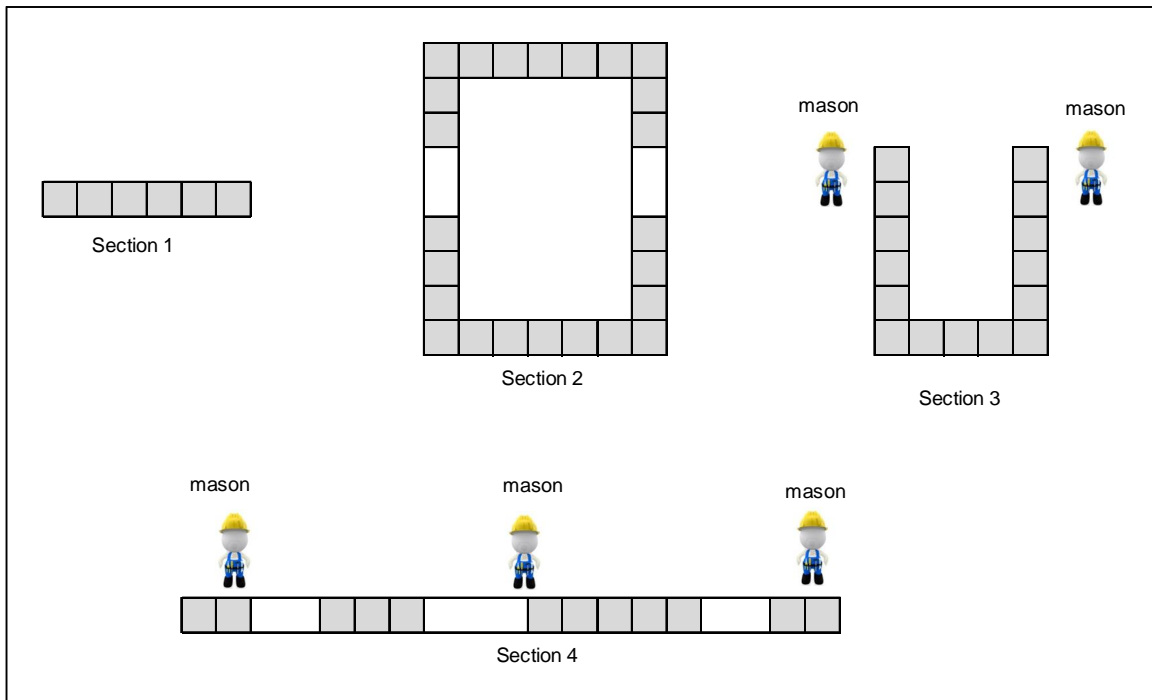

Figure 2- Task distributions for stage 2

2.6 Labor allocation models

There are several approaches that have been developed to allocate human resources in construction to guide the planning process. In the planning stage of the construction, it is crucial to manage labor allocation to ensure the optimal choice of crews and effective utilization of each crew member.

Some studies have been developed to plan workforce incorporating skills. Shahhosseini and Sebt (2011) developed a fuzzy adapted decision making tool to select personnel for construction projects. Lee et al (2010) developed a competency model for project construction and project control teams. The model provided a framework for manpower development which included employment, performance measurement and organizational ability improvement. By changing competency levels, the model evaluated its relation with the performance of projects. Bard and Wan (2008) developed a workforce design model that included movement restrictions between workstation groups. Cai and Li (2000) proposed a genetic algorithm for scheduling staff with mixed skills under multi-criteria constraints. Buchan and Dal Poz (2002) reviewed the mix of skills in the health care workforce. A comprehensive review of further models and extensions can be found in Alfares et al (2004), Burke et al (2004), Van den Bergh et al (2013) and De Bruecker et al (2015).

Other studies have been developed to plan workforce allocation with multiskilled workers. Haas et al (2001) presented a methodology to effectively use multiskilled workers. It documented and formalized the current methods that construction companies use to plan and use multi-skilled workers. Gomar et al (2002) developed a linear programming model to help optimize the assignment and allocation of multi-skilled workers. Bellenguez et al (2007) proposed a branch-and-bound method for solving the multi-skilled project scheduling problem. Liu and Wang (2012) proposed a duration optimization model while introducing the concept of multi-skilling to integrate single and multiple-skilled crews to improve work performance. Their proposal uses a constrained-programming optimization model to minimize project duration and increase continuity in a construction project.

In construction, a number of approaches have been developed to allocate workers. Al-Bazi and Dawood (2010) presented a strategy to allocate crews of workers in the

precast concrete industry using genetic algorithms-based simulation modeling. Lin (2011) proposed a decision-making model for human resource allocation in remote construction projects. El-Rayes and Moselhi (2001) developed an optimization model that uses dynamic programming for repetitive construction projects. Maxwell et al (1998) presented a stochastic simulation program for finding the optimal crew configuration to complete a defined quantity of work under cost and time constraints. Their proposal uses an optimization rule to determine the best crew configuration by measuring the elapsed time and activity cost of each candidate crew. A review of the aspects and modelling approaches in personnel allocation and scheduling in construction can be found in Brucker et al (2011).

However, there is no method in the current building construction literature that combines both technical methodologies as well as real life implications in masonry construction. In other words, a model based on sound technical methods that helps contractors allocate labor, while considering workers characteristics and site realities.

2.7 Well-being of workers

In project-oriented organizations such as construction companies, project managers adopt a temporary work process to complete projects. The configuration of crews of workers is constantly changing and crews are assembled and re-assembled based on the demand of clients and the work load. This dynamic work environment is regularly seen in masonry construction.

In masonry, project demand is unpredictable, which forces managers to constantly adjust the size of crews and reconfigure crews to get the projects done. Workers are often transferred to different projects and even between different roles in a project according to the demand of work. This temporary organization and dynamic environment can influence the motivation and impose pressure and stress to workers.

Workers cannot be sure what kinds of projects or tasks they will be assigned to, the location of the projects, or the co-workers they will work with (Loosemore et al, 2003). Furthermore, given the peaks in workloads and the uncertainty of work, it is difficult for workers to have opportunities for career development and achieve a work-life balance. To address this problem, managers need to implement human resource practices that assure an ethical treatment and the well-being of workers so that workers have a better work environment. However, project management has traditionally focused on planning operations with little attention being paid to the workers (Belout, 1998). The organizational perspective of project oriented organizations such as construction companies in sake of profit maximization and client demands usually prevails over the needs of workers (Turner et al, 2008; Loosemore et al, 2003). Additionally, the lack of opportunities for career growth result in high turnover rates while construction companies have difficulties maintaining and recruiting construction workforce (Gomar et al, 2002).

Workers are an organization's most valuable asset and this is especially true in relatively labor intensive industries such as construction (Loosemore et al, 2003). Workers, unlike other resources, have their own needs and requirements beyond the financial compensation for their work. Workers place a great value on requirements such as involvement, respect, and sense of personal growth (Loosemore et al, 2003). Because of their needs and requirements, workers may represent the most difficult resource for organizations to manage, but when managed effectively can bring considerable benefits (Loosemore et al, 2003). For instance, a project that links project assignments to career development allows contractors to not only develop staff for its future projects, but also helps workers develop competencies and functions for career growth (Lingard and Sublet, 2002; MacKenzie et al, 2010).

At the same time, contractors benefit through increased work control by better using education and competence development that increases job satisfaction and motivation. Projects have better productivity rates where employee work experience is enhanced by assembling teams that consider managers and co-workers as well as appropriate tasks and roles for the workers to work on (Turner et al, 2008). By considering the strengths, needs and expectations of workers, construction projects may not only benefit current workers but may also help attract new workers to the field and increase their social capital (Gomar et al, 2002; MacKenzie et al, 2010; Srour et al, 2006; Loosemore et al, 2003; Pastoriza et al, 2008). Construction companies have duties to identify appropriate projects for the workers to work on and to ensure that he or she achieves career development opportunities (Turner et al, 2008).

2.8 Discussion chapter 2

In this chapter, a literature review search on construction labor and methods to allocate and schedule workers in construction projects was conducted. The first part, namely, the search on construction labor aimed to describe workers in construction, the challenges the construction industry phases today in terms of labor, and the impact of labor in productivity. The second part introduced the labor allocation problem and described the research efforts that have been conducted to schedule and allocate workers in the construction industry. The search showed that there is no model in the current building construction literature that combines both technical methodologies as well as real life implications in masonry construction. Finally, based on the results of the literature search the chapter concludes by determining the need to develop a model based on sound technical methods that helps masonry contractors allocate labor, while considering workers characteristics and site realities.

CHAPTER 3

METHODOLOGY

Qualitative methods are used when an exploratory study is done to understand and gain insight on a specific topic area. To understand the topic, information is usually collected in two forms. One form relies on observations, which are detailed descriptions of situations, events, people, interactions, and observed behaviors. The second form relies on verbal interactions with participants, mainly direct quotations from respondents about their experiences, attitudes, beliefs and behaviors. Both forms, detailed descriptions and direct quotations, are raw data from the empirical world that are collected as narratives without attempting to fit the information into predetermined or standardized categories (Patton, 1997). Rather the purpose is to explore what people's experiences and interactions means to them in their own words and in their natural setting.

Interviews are one method used to collect data directly from participants. Interviews are used to access the perspectives of participants and understand a situation from the respondent's point of view without predetermining those points of view in selection categories (Patton, 1997). The objective behind the interviews is to understand how respondents have organized a specific situation and the meaning they have attached to what goes in that situation. To gather responses, the interviewer provides a framework within which participants can respond accurately and comfortably about the questions that are being asked. There are three basic approaches to gathering responses: fully structured interviews, semi-structured interviews, and unstructured interviews.

In a fully structured interview, the questions are predetermined and typically the interviewer has a standardized schedule similar to a questionnaire.

Questions are closed-ended and fixed and they are asked in the same order to all participants, the way they are worded does not change and no additional questions can be asked to participants. In semi-structured interviews, the interviewer works on a set of questions in advance and outlines specific topics that will be covered before the interview, but the setting is more flexible. That is, questions are open-ended, and the interviewer can change the wording of the questions, modify the order in which questions are asked, give explanations and even leave out questions which may seem inappropriate for a respondent or include additional questions that may provide relevant information. Semi-structured interviews are conducted with open-ended questionnaires which allow collecting direct quotations from participants that not only reveal the way in which they have organized the world, but also their experiences and their basic perceptions. Through the conversations it is possible to probe or extend responses as well as to gather deep and detailed responses that enrich the research process.

In unstructured interviews, the questions are not pre-determined nor the outline of the interview is established and the interview relies entirely on the spontaneous generation of questions which typically occurs as part of an ongoing observation.

3.1 Semi-structured interviews

Semi-structured interviews are interviews in which the researcher explores a few general topics and attempts to understand them from the respondent's point of view (Creswell, 1998). The interview is comprised of a set of structured questions that help initiate the conversation with participants and gather responses on the topic of interest. It is through the conversation process and the questions that emerge from it, that participants are able to frame their responses (Marshall and Rossman, 1999) and interviewers can ask for verbal clarification of what is said by them (Fontana and Frey, 2005).

This setting helps gather information that is somehow conversational, allowing respondents to share experiences and personal knowledge that would be difficult to collect if the format was more structured and responses were pre-determined.

Semi-structured interviews do not impose pre-existing conditions on the setting (Patton, 2002), but rather help in gaining an understanding of the research questions by encouraging participants to share their own personal perspectives and experiences (Hesse-Biber and Leavy, 2006). In other words, the focus is to see the setting through the eyes of the participants. Semi-structured interviews enable the gathering of “thick descriptions” (Patton, 2002) that help identify the context of practices and can help uncover complex interactions between people (Creswell, 1998).

Semi-structured interviews have been used in a number of construction studies. Bassioni et al. (2005) conducted semi-structured interviews to develop a framework for measuring the business performance of construction organizations. Green et al. (2008) investigated through a series of exploratory interviews how firms continuously adapt to changing environments and shape their competitive strategies. Redmond et al (2012) conducted semi-structured interviews on using cloud computing as integration platform for Building Information Modeling (BIM) applications. Agapiou (2002) conducted semi-structured interviews with participants from all the levels of a firm to assess their general perceptions of women’s roles and contributions in the construction industry. Almahmoud (2012) obtained relationships between project health and project performance from a series of semi-structured interviews to help project managers identify shortcomings in the early stages of a project. The conclusion from these studies is that the overall goal of semi-structured interviews is to collect data on the topic of interest and explore emerging topics.

While it is useful to allow some flexibility in the interviews to discover new diversions, it is necessary to have a protocol to guarantee that complete and consistent information is received across the different interviews. The protocol also guarantees that the data is meaningful (Green et al, 2010) and the central topic and the concepts derived from the literature are discussed. For that reason interviewees need to be selected on the basis of having a relevant expertise on the topic under investigation, which can provide data to reveal concepts in support of theory development (Randall and Mello, 2012).

One of the major challenges that arise from semi-structured interview studies is to demonstrate the validity and reliability of the data (Green et al, 2010). Validity is concerned that the data collected is accurate, relevant, and meaningful. Since one part of the analysis process is to provide descriptions of the data, these descriptions must demonstrate the validity of the data. Descriptions must make sense to the reader and must convince the reader that the researcher was part of the culture by using unique features and industry-specific terms. On the other hand, reliability is also needed because it determines that the results are stable, that is, similar and consistent results can be found under similar circumstances. Reliability also requires enough detail, but the purpose is to provide enough context for readers to determine what specific aspects of the setting can be generalized to similar situations (Phelps and Horman, 2010).

Semi-structured interviews were selected for this study since this method of interviewing allowed the researcher to give some form to the interview while letting new topics emerge from respondents' knowledge (Green, Kao, & Larsen, 2010). Given the flexibility of the format, semi-structured interviews enhanced the research questions by allowing respondents to share experiences that otherwise would have been difficult to collect if the format was more structured and responses were pre-determined.

In fact, semi-structured interviews allowed the interviewer to probe the interviewee for clarity or for more detailed information when it was needed (Creswell, 1998).

The overall goal of semi-structured interviews was to understand and explore the factors and drivers that masonry stakeholders use to makeup crews in masonry construction. The sample of interviewees for this study was drawn from people directly involved in labor management in masonry construction, whose opinion was relevant for the research and who could provide as much information as possible on the research topic (Miles and Huberman, 1994). The sampling approach was that of purposive and theoretical sampling (Hesse-Biber and Leavy, 2006, Creswell, 1998). Purposive to guarantee the participants in the sample were knowledgeable and familiar with the processes under investigation and were experiencing or had experienced the phenomenon (Creswell, 1998). Theoretical to guarantee the data was sufficient to develop explanations and theories.

The sampling approach was formal based on interviewing people who had specific characteristics to fulfill the needs of the research requirements and the conceptual framework (Miles and Huberman, 1994). For this reason, only masonry stakeholders who are involved or had previous experience in the makeup of crews both in the office when planning work and in the jobsite coordinating and performing work were included in the sample. It was determined that only stakeholders responsible for planning and organizing workers with a management position are knowledgeable with the makeup of crews. Therefore, the target population included foremen, superintendents, project managers, contractors, and industry representatives. Masonry instructors were also included since they all have had experience running work as project superintendents or foremen. Masons, laborers, and other support workers were not included in the sample since they do not know the factors that influence the design and makeup of crews. The sample was small, but it was studied intensively to generate

a rich amount of information since the idea was not sampling people but sampling incidents and experiences that denote the work that those people do.

Semi-structured interviews were conducted to find saturation, which is the point where there is a well-developed theory and more participants will not provide new data to the existing data. In other words, saturation occurs when a new participant is repeating what others have reported (Creswell, 1998) and when concepts and relationships between concepts are saturated. Creswell (1998) has stated that usually twenty to thirty interviews are conducted for qualitative research, while Bertaux (1981) has argued that fifteen is the smallest acceptable sample size in qualitative research and Guest et al. (2006) found saturation with twelve interviews for a purposive sample. Hesse-Biber and Leavy (2006) have stated that the size may vary according to the analysis and if data initially taken is sufficient to answer the research questions and all subsequent questions that arise afterwards. For this study, twenty seven interviews were conducted.

3.2 Information from the interviews

The initial stage of the research comprised semi-structured interviews to gain useful insight and knowledge of implicit practices in masonry labor management that could only be collected through interactions with practitioners. The purpose of the interviews was to not only understand labor requirements but more specifically gather knowledge to inform the rules and drivers for the design and makeup of crews. To expedite this goal, four main objectives were defined (i) To identify the type of workers, the activities, and the roles in masonry sites, (ii) To understand and discuss the factors that influence the size, the composition, and the process of building up crews, (iii) To explore and discuss labor management practices such as task and role distribution in masonry sites,

and (iv) To explore and examine the rules and drivers for the design and makeup of crews and practical criteria that masonry practitioners use for staffing projects. The four objectives were then formatted into three categorized sections, namely: labor requirements, rules for crew design, and drivers for crew makeup.

Labor requirements: this section comprised of two questions initially inquiring the type of workers, roles, and activities in masonry sites. It also defined the tasks and responsibilities of masonry workers.

Rules for crew design: this section focused on investigating and exploring the rules used by practitioners that directly impact labor needs and the size of crews in masonry sites.

Drivers for crew makeup: this section was designed to explore criteria used by practitioners in making up crews. It openly examined the guidelines that practitioners use to form efficient and productive crews.

Based on these categories, an interview protocol was developed as a guide during the interview process (see Table 1). The protocol was used to ensure that the topics of interest were pre-specified and covered (Creswell, 1998). Although the questions in some cases were reworded as needed (Tasshakori & Teddle 2003), they were all covered by the interviewer to make sure the information gathered from participants was complete. The interview questions were informed by academic and trade literature on masonry construction as an integral part of the exploratory research (Jarratt, 1996) and were complemented with two visits to the Training Center at the International Masonry Institute (IMI) in Bowie, Maryland, US.

3.3 Sample of interviewees

The sample of interviewees for this study was drawn from people directly involved in labor management in masonry construction, whose opinion was relevant for the research. The sampling method was that of purposive sampling (Creswell, 1998; Hesse-Biber & Leavy, 2006). Purposive sampling was intended to guarantee the participants in the sample were knowledgeable and familiar with masonry construction labor practices. The sample was intended to include participants that were experiencing or had experienced similar work responsibilities of organizing workers and designing crews in masonry construction projects (Creswell, 1998). The sample included two types of experts as defined in Redmond et al (2012): those whose expertise is a function of what they know (epistemic expertise) and those whose expertise is a function of what they do (performative expertise). An epistemic expert has the capacity to provide justifications for a range of propositions in a domain while a performative expert has the capacity to perform a skill in accordance to the rules and virtues of a practice (Weinstein, 1993). The experts chosen for the interviews were a mix of both epistemic (industry representatives, instructors, project managers, and contractors) and performative (superintendents and foremen). In some cases, some experts were both epistemic and performative. All the respondents were known to have a strong association with masonry construction.

Previous to starting the interviews, two pilot interviews were conducted. Based on the results and findings of the pilot interviews, the wording was revised for proper use of terminology and the questions were selected for data collection. The interviews comprised a set of close and open-ended questions, which provided more flexibility in the data collection process and allowed for clarification of the responses (Creswell, 1998). The interview protocol was made following the Institutional Review Board (IRB) procedures.

Before starting the interview, each participant was given a copy of the consent form or the consent form was read to each participant explaining the purpose, procedures, and the confidentiality of the study. Each participant was asked whether or not they preferred to be audio-taped and were told that both audio-taping and note-taking were acceptable for the researcher.

During the course of the interviews, it became apparent that practitioners considered different factors and used different criteria to design and makeup crews in masonry projects. Twenty seven interviews were conducted on a varied sample of masonry practitioners all based in the United States. The group consisted of interviewees from firms and organizations nationally recognized for their trajectory with masonry. Figure 3 shows the area of operation of respondents. After conducting the twenty-seven interviews, the consistency of the responses observed became apparent suggesting that the responses will not be significantly different from that of a larger sample.

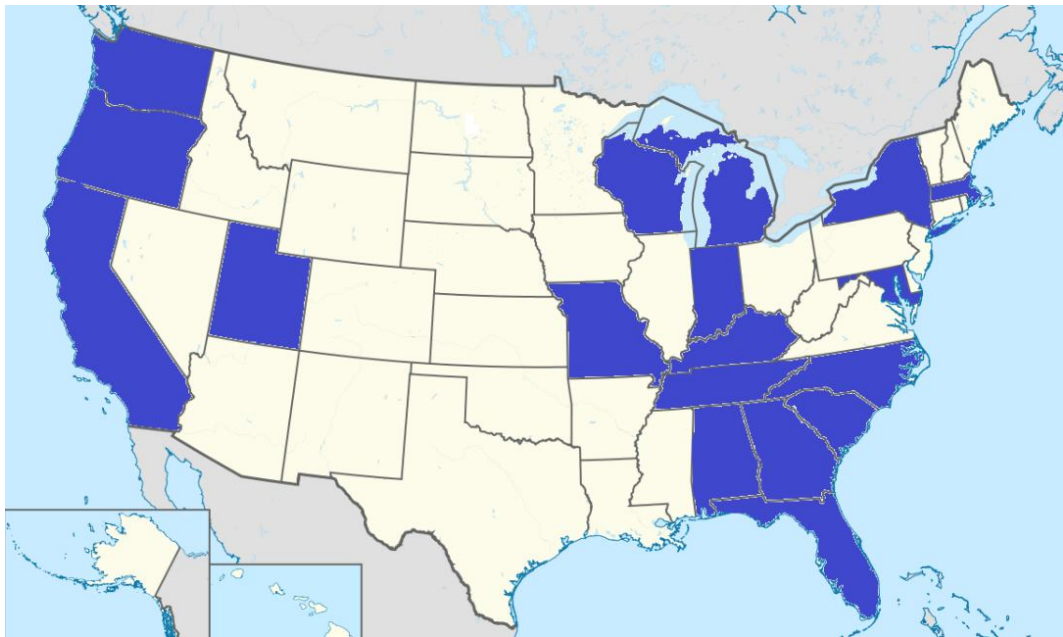

Figure 3- Area of operation of respondents (states colored in blue)

The experience in masonry construction ranged from 10 to 46 years with a mean of 29.2 years. The respondents interviewed were asked about the title that best described their line of work. These included nine superintendent or foreman, seven contractors, seven instructors, two industry representatives, one superintendent, and one project manager. All of the interviewees indicated they started their masonry career as either laborers or apprentice masons. In some cases, the interviewees also indicated that they are second-generation or third-generation bricklayers that were raised with the trade. In regards to their current work, foreman or superintendent interviewees indicated they spend all of their time on the jobsite running jobs in contrast to the other interviewees who divide their time between the jobsite and off the jobsite. All the other interviewees (industry representatives, project managers, and contractors) alternate their time between the site and the office, except for instructors. Instructors give continuing education to both apprentices and masons, so they spend most of the time in the classroom. The interviews were conducted from September 2013 to July 2014 and included both phone interviews and face-to-face interviews. The length of the interviews ranged from 50 to 70 minutes and the sample of questions included is shown in Table 1.

Table 1- Interview protocol

Number	Question
Q1	What type of workers do you have in a masonry site?
Q2	What does each worker do?
Q3	What is a standard crew?
Q4	What is the size of a crew?

Table 1 (continued)

Q5	How do you build up your crews?
Q6	How many laborers do you assign to a mason?
Q7	How do you determine the number of masons per wall?
Q8	How do you assign workers to roles? Who goes where (saw, mixer, forklift, general laborer)?
Q9	What factors do you consider when assigning a laborer to a mason?
Q10	What factors do you consider when grouping masons in crews?
Q11	If you have different wall sections, which worker goes to which wall?

To illustrate the detail of the responses, examples of common responses to each of the questions are detailed below:

Q1. What type of workers do you have in a masonry crew?

Contractor 1: *"We always have a foreman on the job which is a bricklayer foreman or a superintendent which ever you want to call him- now sometimes he can work with his tools in his hands and sometimes he does not work with tools in his hands - depending on the type of project and what is required of him - almost 99% of the projects we have, you know - there are safety meetings or project scheduling meetings with the owner or general contractor - there are different tasks that keep him from being able to work with the tools in his hands - so you take that into account when you build your crew."*

You work in terms of productive masons, which are the actual ones that are putting materials on the wall so typically - you have a foreman, masons that are working- as far as placing units in the wall when I say working- and then your laborers or helpers”.

Contractor 4: *“We typically have a management person on site, our foreman on site is essentially a superintendent OK - they have all the power to make all the decisions, financial and schedule and all that kind of stuff and we have a project manager that’ll be in the office they aren’t on-site every day - he would go to the site once a week or every 2 weeks, so the guy that is a foreman is more like a superintendent - sometimes we have a really big job so we may have 40, 50, 60, 70 people and we’ll have a couple of big foreman and we have some sub-foreman that help coordinate the individual crews, you know, so our foreman or our supervisor they typically aren’t putting units but they are walking around and making sure things are going the way we talked in the morning and getting things ready - so for example if the guys are working on wall A and it takes 18 guys to get it done in 2 weeks, he’ll be preparing wall B and wall C to place those 18 guys so when the guys are finished they can jump in wall B and wall C and keep working non-stop - and then we have laborers that are the ones that tend the masons”.*

Q2. What does each worker do?

Instructor 3: *“The straw boss is usually a person that works and is laying material in the wall - he's looking for production and looking at who is working and probably laying brick - usually they put the apprentice in the saw- they can make more money on a wall with a journeyman - a forklift is a laborer that has a*

license for it- if something happens then you see a foreman that jumps in the forklift- not everybody drives the forklift- a laborer sets the scaffold and is certified to building scaffold- but you - you have to have a person that is certified to building scaffold for a certain height”.

Contractor 2: *“So we have- we have masons and mason tenders that assist the masons - so my work crew would be calculated by the amount of masons needed to complete the tasks that we have in the time frame that is allowed and - I will supplement the amount of masons needed with the amount of mason tenders needed in the project. So my mason tenders will be mixing the mortar, stacking material, building scaffold, driving the forklift, operating the machinery, giving all the material to the mason, clean-up - everything that’s involved except the actual installation of the unit -the masonry unit- that would be the mason - so the laborer or mason tender is responsible for all the preparation work and the mason is responsible for the actual installation”.*

Instructor 5: *“A mason tender will be the guy that will be in the saw and will be moving the material with the forklift - In some states they have the operators that will operate the machines - sometimes if you are a good laborer they will buy your operator card – and in other states is just a laborer that operates the saw and the forklift”.*

Foreman 6: *“In a non-union site, the masons can be assigned all over to different tasks- if it’s needed to get the job done- for instance a mason might clean the floor, mix mortar, grout but in a union the masons cannot do that –*

they can only lay units in the wall- the laborers are the ones that clean the floor, mix mortar, and do the grouting”.

Q3. What is a standard crew?

Contractor 7: *“A standard crew for brick and block jobs is a foreman or superintendent whatever you want to call it, layout guy -half the time laying walls and half the time placing units- the saw man, 6 masons, 6 laborers and one labor foreman, one driving the forklift, one in the mixer. A laborer building the scaffold is not part of the crew. It seems that is the most productive group for us”.*

Instructor 4: *“So a typical crew would be one foreman, 6 masons that are working - as far as placing units in the wall and then your 3 mason tenders - and sometimes we have a labor foreman on bigger projects where you may have 6 or 8 or 10 laborers on the job, so you have the labor foreman that organizes- cause they might be working in different areas at the same time - so you may have multiple crews throughout that project - so a labor foreman would be responsible for organizing the laborers - who’s needed to work where, what their tasks are - and that sort of thing - that labor foreman wouldn’t be totally non-working - he may be operating a piece of machine part of the time, but yeah a lot of time he is not working and doing more supervisory type role”.*

Q4. What is the size of a crew?

Contractor 2: *“That varies in terms of how much work is available to us, in terms of - you know square footage or linear footage of wall and the schedule - you know - you have jobs anywhere from like 50,000 dollars to 6 million dollar contracts OK? so you have 120 guys on one job and you have 2 guys in one job,*

so it goes back to the schedule for one thing and – time - how much time we have to complete it and how much building is available to us - so you kinda look - for example you have 200 ft. of wall you can put 10 guys on it, that's kind of like how it comes to us”.

Contractor 4: *“A lot of times it depends on how big the project is - if the project is sizeable and we have maybe 12 or 14 masons on the job, then we would have an assistant with the foreman - some foreman can handle more guys better than others - it just kinda like some baseball players can hit home runs and some can't - is just that - some guys are better at delegating and you just have to know as the owner of the company that - you don't put a guy that's not good at delegating on a job with that many men - that doesn't mean that he's a bad guy - that's just placing your men - that's the part that you have to know your people very well to know where you can maximize their strengths”.*

Instructor 4: *“You really have to analyze each wall, each project, and determine what's best to put in that wall crew-size wise - and that's when you get - you have your superintendent, you know, your foreman and your project manager all looking at the plans and you - you talk it out and determine what's best - a lot of times in a project there is areas you can work in and then you may run into a problem outside your control that causes you to cut down your crew or to add to your crew that sort of thing”.*

Like...

“For instance you might be working with maybe 10 masons and you know, you finish that wall and there might not be another area ready for you to put that many masons cause they have to pour concrete ahead of you and maybe height seal ahead of you that sort of thing - maybe the other trades didn’t get their portions ready in time for you to be able to use that same crew so you have to adjust - cut your crew down, maybe you go from 10 masons to 7 masons and then once that original job opens where you can use your 10 masons you build up your crew again - and a lot of times it is not because of us it might be due to other trades”.

Q5. How do you build up your crews?

Industry representative 1: *“First day you need a superintendent, a mason, and laborer because you have some layout to do. Then the next day you need a laborer in the mixer, some masons and laborers and then you keep bringing in more masons to build your walls and - if they need scaffold then you have to bring a scaffold crew and grout people and rebar”.*

Contractor 5: *“So sometimes the customers that we work for - they think they know our business better than we know our business - so they are telling us you know you need 6 masons from day one and I say no I have 2 and 2 more coming and that’s what I need, but - they try to make you work on some things that you don’t necessarily want to do and that - like we talked - not because you have too many masons on the project you are going to have the production that you need - it might be counterproductive - and then you think you have a perfect crew and everything is working perfectly and then you get a call at six in the morning, my daughter is sick I need to take her to the doctor that sort of thing - now instead of*

6 bricklayers and 3 laborers then you have 4 bricklayers and 3 laborers and you have more laborers than you need and is costing you money you know - you are not as productive as you should be”.

Foreman 3: *“It always depends on how much work you have for the day. Once you get the sections ready you bring in more guys and increase your crew and then if you don’t have much space then you move guys to another job. You as a foreman can plan for that variation because you can see it coming - it’s very easy - so you cut your crew or you increase your crew - typically you start slow and then bring in more guys and then you end with just a few guys”.*

Contractor 6: *“Generally when we are starting a job, even if we figure a job with 6 masons- as our average crew- and we determine this job is a 6 mason job and we are going to put 6 masons on this crew- on the first day you don’t have enough work ready for 6 masons to be there- you might only have two or three coming in on the first day until you get some work ready and the contractor spreads you out and gets more slabs poured and more foundation in and then we build up to the 6 men crew - so all of that has to be evaluated as we go and take that to a different level- like on a Target store where 12 masons are needed we can’t put 12 masons on the very first day- there is just not enough work until it builds up - so there is a build-up of the crew when you get to the end of the job there is a build down of the crew”.*

Q6. How many laborers do you assign to a mason?

Contractor 4: *“Typically is a 2 to 1 ratio - sometimes we will work say on a Saturday and we get the scaffold ready all set and we spend like 4 laborers that*

day with no material going in the wall, then Monday, Tuesday, and Wednesday let's say we would have 12 masons and I could probably get away with 5 laborers if we were totally prepared - and we do it that way sometimes, but still it works out as a 2 to 1 ratio - it might change like - If you are doing intricate work, let's say a building that's got arches in it - or pretty heavy intricate work you got a lot of pockets or whatever - typically you won't need too many laborers, you could work - 8 bricklayers and 3 laborers if you're going slow - a lot of times if we're doing a big block job like with 12 inch block and they're going fast we might have to have an extra laborer - so it all depends - like if we're doing a long dead wall sometimes we need to have an extra laborer".

Industry representative 1: *"Typically you have 1.5 laborers per mason - sometimes I've seen 2 laborers per mason but you really have to make sure they are getting some production. I've also seen 1 laborer per mason".*

Project manager 1: *"We typically work with a 2 to 1 ratio, two masons to one laborer - but it may change according to the spot where they are working - if it is too tight or difficult to access, it might require an extra laborer or two for getting the material - so in that case we will go 1 to 1- and if- if it is easy accessible we might go 3 to 1- and it depends on the material too you know - if it's brick veneer the ratio might be 3 to 1 – brick you know- it does not require as much labor as load bearing jobs such as CMU - CMU is more labor intensive because of the grouting and all the material and stuff- so you might go 2 to 1."*

Industry representative 2: *"The ratio of laborers per bricklayer came in the labor negotiations you know - it has- I mean the ratio has a range of 1 brick layer*

to 1 laborer to up to 3 brick layers to 1 laborer- and I would say 99% of the jobs use that ratio”.

Q7. How do you determine the number of masons per wall?

Contractor 4: *“Well if it’s like a 30 ft. long wall, I would only wanna have two bricklayers on it- so that they have room to work I mean you don’t want a guy that’s spreading mortar and laying brick and- you know you want him to be able to go like 15 ft. and they meet in the middle, but if you put 4 on it then they can only lay about 7 ft. and then they stop - and that’s not very productive - you wanna be able to give the guy a chance to spread the line and - kinda be like a race horse you know - let him- you know- let him do something cause if you have the guys too crowded elbow to elbow you are not going to have very good production – so 15 ft. of wall per guy or maybe even a little more”.*

Foreman 3: *Well- how many blocks in it - a mason- if he’s got more room to lay block, he’ll lay more block - if you put too many on there, then the count goes down because - you’ve got too many of them, too crowded, rather than laying 10 or 12 blocks a course each - like a 24 block long wall, I put two on there, they’re laying 12 blocks each - they put, say 15 courses on there, they lay almost 200 blocks - if I put three up there, then they only lay 100 blocks each- you see what I mean? - it takes away from what you’re trying to do - smaller walls, you don’t want to put two in there”.*

Instructor 1: *“Well - we want to make sure that each mason would have at least 20 ft. of wall to work on you know - per course - you understand how we lay the block - we pull a line and lay to that line and once we have our leads, our corners*

established - you would want each guy to have at least 20 ft. of wall, preferably a little more than that, cause 20 ft. will be 15 block and you want to have that figured out, so when you're laying that course of block along that line, that all of those bricklayers or block layers will be finishing their section of wall at the same time, so then the line will be raised and you can start again in the next course - you know - if some of the guys have to stand there and wait until - some of the other guys finish their section of wall - well the guys waiting are non-productive at that time - you know you want to make sure everybody is finishing the line at the same time and you would raise the line and then everybody will go again".

And if you have too many guys...

"If you have too many guys, let's say everybody only had, you know, only 10 ft. of wall or less well - they're each only laying about 7 blocks per course - and you are spending more time raising the line than you are getting units in the wall - so that 20 ft. makes it easier for the workers or for the masons to meet that average of 150 or 160 units a day".

Industry representative 1: *"Sometimes you need a certain amount of space per mason depending on - you need room to kind of like spread out - you could put too many people on a wall, OK? that will slow the process down - it's too crowded - they might not be able to spread out mortar on the wall all that freely - and if you've seen work then you might be able to understand this or you might run up to somebody that will have to explain it to you - but If I've got 4 guys on a wall and they are all meeting, I have two closure points OK and those closure points that last unit in where two people meet, is the slowest unit on the wall - so*

if I've got two guys on that wall I've got one closure point – I got 3 guys laying on a wall, I've got two closure points - I got 4 guys on a wall two can start in the middle and go either way and I still got two - the more people you've got on a wall, the less productive they could be depending on the size of the wall. Four people on a 25 ft. wall, you are not going to get any production at all - four people on a 100 ft. wall - you probably are going to maximize production – it's all relative”.

Q8. How do you assign workers to roles? Who goes where (saw, mixer, forklift, general laborer)?

Contractor 4: *“Some guys are really good at driving the forklift and they are qualified to run it, some guys are really good at building scaffold, of course they have to have their scaffold builder's card and just - well a lot of it is based on experience, some guys are better with the tractors than others, some guys are always the guys that you have in the front building scaffold, some guys keep the mortar mix better than others and you just kinda know that - and a lot of the guys - they have been with us for a very long time so you just kinda put them in the job and they know what they're supposed to do - you kinda have to know the skill set of your guys and you can place them accordingly”.*

And for the masons...

“Some guys are better at the saw than others- believe it or not - some guys are better at laying out which means you're laying your first course and laying at your control joints and sawing the flashing, you know understanding what heights you have to hit and - some guys are more meticulous and can kinda do that and don't

get frazzled cause it takes a little bit of thinking, where other guys are better at doing - they are maybe speedy and you just kinda set the table for them and other guys just set the table and they kinda come and keep the pace up you know - it's just a matter of judging and learning from working with other people - some guys are better at laying out work on the ground so you have them laying out as others are getting the wall topped up, working around pipes and stuff - it's just - again it's just like a basketball or any team - everyone has a certain position and as the person in charge you have to maximize wherever their strengths are - and it doesn't mean that one is better than the other is just that one guy is better at one thing than the other and vice versa - is not that any one person is better than the other or less valuable is just human nature that some people are going to be better at certain things than others".

Instructor 2: *"There is a place for everybody in the job - you know what I'm saying- like the guy in the saw- usually the guy in the saw is an apprentice because he is cheap help, they can make more money with a guy that is experienced on the wall- in the bricklayer end is usually the apprentice goes to the saw all the time- or they take an apprentice and he stays on that saw for the whole job - the forklift is usually a driver on it, OK? an depending on what part of the country you are in, it could be another union or it's a laborer that's got a license for it, not everybody drives the forklift- it's usually a laborer with a license- and in this part of the country when something goes wrong, you'll see a foreman jump on that forklift- to make sure that - if they got no mortar up there nobody's working so you will even see a foreman jump in those mixers too, if they aren't getting the mixer fast enough and stop, you'll see a foreman, that's why it gets stressed out being a foreman but you get extra money to be that foreman - there*

is money in every pod in being a foreman for every company- don't forget that when everybody goes home the foreman might stay on the job overlooking things or come in an hour before the job starts, he is walking around looking - the scaffold it's usually laborers and its usually carpenters setting up the first lettings, depends how high it is, a lot has to do with heights and in the new laws it's not a competent person you got to have a person that's got a license after a certain height – it's a staging you know what I mean- like a lot times certain companies they have a company that will come up to set up the stages- you have to have a license and depending on how much weight you have and- well there are some things that play into factor- the mixer is usually a laborer and is usually a company guy because they want to make sure that mix is consistent, especially when you are using colors, that there is no change in the mixer and now the mix bags are already premixed and it is setup next to the mixer with how much material goes”.

Contractor 5: *“There are certain guys that are good at cutting units and they are good at basically mocking up the block, speed is better, they know how to do it, - they will run the saw, other guys they'll gaol out the saw I mean you can see how much its build up- I mean it's really just a sawing operation so it's always cleaning out and keeping things tidy and there are certain guys that do that better than others- to drive the forklift you have to have actual certification on the lift so that leaves out a group of guys and then certain guys have better skills that is actually operating the lift than others - and so there's tight corners, tough conditions to get to - you wanna have an extremely skilled guy vs like a wide open site, a lot of visibility- certain guys are just better than others and so we'll consider the site conditions of the job and what it needs- and that'll help out pick*

who our staffing is and if we have smaller lifts- not as much height that we are using- that operator can be different than if it's a 10k unit that reaches 54 ft. and we are having to boom out and put our records and maybe using like stone misting with inserts- that's a different style operator than just taking a pallet and putting it on a scaffold - so different skill sets drive what the needs are in terms of who we staff it with- and- oh yeah mixing is pretty basic - I would say mixing is the easiest I mean you got be able to have the ratio correct if you are mixing any kind of mortar or sand vs mortar or the sand boxes, grout mixing is just- is just mix plus water so you can't really mess that up- so it's the most basic job I would say out there in terms of what actually- it is extremely repetitive, do it and just pour it- and so it's a need but is a basic need- and then scaffold building, forklift driving, saw cutting those are just kind of like the other items that is not just laying up block or brick but we have to think through who is doing that, is has to be a scaffold competent person, that knows how to build that scaffold, make sure its tagged, make sure it's got all the railings done correct, the tiles points if needed, it's a deeper understanding of what's in it so – and there are certain guys that tend better than others and that's fairly basic too so it's just knowing the needs before they are actually at that point - so I mean it is kind of like wire needs to be there, block has to be stock there, mortar to be mixed and there's usually a guy that's on that floor making sure all the different helpers are giving them what they need and that's keeping up with the inventory, making sure all the vendors are shipping correctly for what we need as far as quantities, and our lead superintendent makes the calls for the orders for products but he usually leans on one main helper that's got a big picture of what we have for basic quantity of products, overall needs of the job- that guy helping that mason may be pretty simple but there's usually one lead guy in that floor area that's got a

really good feeling of products other than just the block, wire or grout and what that mixer is doing, he's keeping up with the cuts, he's transferring what they need on top of wall, make sure they are giving it to the saw guy correctly so yeah it's a sync between all those different players and people".

Q9. What factors do you consider when assigning a laborer to a mason?

Industry representative 2: *"Some laborers (going to training school) will get certified for scaffold building, scaffold use, drive the forklift, signalling - in some parts of the country they don't have schools cause they think laborers are a unskilled craft - so if they are certified I will place them operating machines or building scaffold and if they aren't then any laborer with any mason".*

Project manager 1: *"With the laborers is kind of like the same as the masons, not all the laborers have the same skills and it is important to recognize this - like some are good at just tending the masons, but some are good at erecting scaffold or operating the forklift".*

Foreman 4: *"Well I hate to say it but laborers aren't as specialized as masons - most of them do pretty much the same - so with them it doesn't really matter who goes with whom - but if I can, I try to keep the same guys with the same guys throughout the job".*

Instructor 5: *"Some laborers are better at stocking, they know how many blocks they will have to put in the staging and in between the mortar boards you know- they can count and know how to do that count - some guys do exclusively staging and some guys just mix the mortar and prepare the material for the*

masons- laborers bounce a lot in the different areas so you don't really pay much attention to how you pair them with the masons".

Q10. What factors do you consider when grouping masons in crews?

Instructor 5: *"Well - once you get your crew established you know - we usually kinda team up the crew- if we can you know- if we were to pick guys- we would pick two guys that work well together you know- cause they can work more productively you know - everybody has their own personality and stuff and - and it just seems to work out you know -if- it is like any of us in any job - if we are working with our colleagues and we get along with them, well it seems to be a little bit more productive than if we're like I really don't like that guy you know - it will be a miserable day if I have to work with him so we like to work that on".*

Any other factor...

"Yeah, certainly their skill level that would depend on you know - if you have a let's say, you're working on the front of a bank building or something where they have some fancy work - you would want to try to pick up your more skilled masons to do that type of work and you know everybody - they can be qualified journey workers, but everybody has a little different skill level just like if you know - I use this analogy with my students - like a basketball player you know, a professional basketball player they might all be very good but yet there are some that are still better than others you know - maybe you have some masons that are good and skilled and everything, but they are not just quite as reminded as some others, so maybe just put them onto walls that maybe they are not shown you know, not as in a highly visible spot you know, or if you have two apprentices

on the job you will often put them working in an area where their skills can grow without challenging them too much at first - like some guys are just neater, some guys- they take a lot of pride in their work and they just - you know they can make it look effortless and they just do really, really nice work, and other guys do adequate work but when you compare you know- the very best to the average guy you can see that the best guy is really you know, his work just shines - an so as a foreman you get to know that so if you are working on a spot where - heights are really critical and you - you know that well this mason stays right on heights and he will continue to check and I can trust him to -you know if I tell him he has to have this bearing plate at 16 ft. 8 and 3/8 inches off at the 100 mark you can count on him - he's gonna have it there where maybe there are some other guys that they can be plus or minus an inch somewhere and they just don't bother".

Project manager 1: *"Some guys are good at brick and no so good at block. Some are better in stone than in block so we like to make sure they are assigned to the project where they can use better the skills they have - some people work in detailed areas better than others - for instance intricate corners, or arches or detailed work - and – and also you don't want to have your best guys all in the same job in the same crew and then have the ones that are not so good together - so it's important to have a mix and - generally speaking if you have A guys mixed with B and C guys, it kind of like helps pick up production".*

Foreman 7: *"You team up people that are going to get along, that work well together - and have the same ideas - that way you get the best production out of it- I don't team two guys that hate each other- it's hard to get production with two*

people that are going against each other - and you sometimes try to put guys that have the same speed because your wall is going to be as slow as the slowest guy - so you better have two masons that have similar speeds so that none of them is waiting for the other”.

Q11. If you have different wall sections, which worker goes to which wall?

Project manager 1: *“We always look at the strengths of the guys – like some guys are better at certain things than others and it’s up to us to place our men to get the optimal production out of them - like everybody is good at certain different things - some bricklayers are good at brick some are good with block - some are better with the - technical work, some are a little faster than others - and those are all good attributes and it’s just- is to us to recognize and know all our men and utilize their strengths to - to get the projects done - you know - it doesn’t mean that one guy is better than the other is just that they are all better at different things so you better take advantage of that.”.*

Instructor 1: *“There is a place for every guy in every job you know – like there are guys that have better hands for certain things - some people are good at corners and openings and are very detailed - some people can go just straight and you know those guys –so you put the fast guy in the long straight wall -if you put him doing work around a bunch of windows he just can't do it – like- not every guy can build an arch - not every guy can keep going around windows and not make a mistake - everyone has something special that they can put to you - everyone has a different talent - some people are better qualified than others”.*

Contractor 4: *“Well all of my employees have a - they have a basic - they’ve gone through an apprenticeship which is a 4 year program, so when they come out of their apprentice school they have all the capabilities, they have all the tools that they need to be able to perform all the main tasks that we have - what happens in reality is certain masons have more experience laying brick, some may have more experience laying block - so each project is different in the material that is used or the type of walls that you have and there is always - there is a different level of expertise needed per project so I would - I know the strengths and weaknesses of each mason and each mason will be assigned depending on their abilities, their strengths - so I make sure I put the proper people on the jobs, and it may sound silly but there is definitely criteria that goes in that - and depending on who you are working for, the different owners and the sophistication of the owners and general contractors that you work with- it may require more polished individuals to be able to communicate with those owners- you know there a lot that goes into that”.*

Foreman 6: *“The long wall that has nothing in, it requires more laborers because the masons are going to be installing more units in a day - so 1 laborer per mason - 1 man in the forklift, 2 in the scaffold and maybe 6 masons- you might even need 1 extra laborer to give more material. And I will put my fastest masons, they might not be the more crafty, but their quality is good. If you have the same straight wall but it now has 10 windows, each mason has a plumb and everything is levelled, everything is slower- I am looking for masons that are more quality than fast, the highest quality- there is more expertise needed in that wall – and because the masons are spending time in the cuts, there is no need for so many laborers- I might need only 1 laborer in the scaffold”.*

3.4 Discussion Chapter 3

In this chapter, a literature review search on semi-structured interviews was conducted. The search aimed to describe why this method was selected as part of the research effort to understand and gather knowledge about masonry site realities. After the search, an explanation of how the questions were developed as well as the questions included in the interview protocol were detailed. The protocol included questions to explore and examine the rules and drivers for the design and makeup of crews and practical criteria that masonry practitioners use for staffing projects. Basically, the protocol was divided in three categorized sections, namely: labor requirements; rules for crew design, and drivers for crew makeup. Once the protocol was finalized, a description and characteristics of the interviewees were provided. Finally, an illustration of the responses and examples of common responses are detailed.

CHAPTER 4

CURRENT PRACTICE

The purpose of the interviews was to not only understand labor requirements, but more specifically gather knowledge to inform the rules and drivers for the design and makeup of crews. This chapter summarizes the responses to the questions in the interview protocol and aims to describe current practices in masonry. To detail current practices, each section, namely labor requirements, rules for crew design, and drivers for crew makeup summarizes the responses to the questions and visually shows the conditions of the site, that is, illustrates masonry site realities.

4.1 Labor requirements

This section comprised of two questions initially inquiring the type of workers, roles, and activities in masonry sites. It also tried to define the tasks and responsibilities of masonry workers.

Q1: What type of workers do you have in a masonry project?

In identifying the type of workers that are present in a masonry project, all the twenty seven respondents pointed out there is a superintendent, a project superintendent or foreman, masons, and laborers. In six instances respondents stated that they use an assistant foreman to help the foreman supervise workers, layout walls, and install door frames. Six respondents pointed out that often times there is a mason foreman helping the foreman supervise masons and making sure the masons are working at proper times per union regulations. Eight respondents claimed that often times there is a labor foreman working with the laborers and making sure the laborers are working at proper times and giving instructions to the laborers on how to build

scaffold, where to put the mixer, and overall making sure the masons have all the material at hand to build the walls.

Q2: What does each worker do?

Responses to this question denote a great deal of similarities in the tasks and responsibilities that each worker has in the jobsite. Some differences in terminology, tasks, and personnel needs were seen from respondents that operate in union states compared to respondents that operate in non-union states.

All the twenty seven respondents pointed out there is a superintendent that oversees the jobs and visits the projects regularly to make sure the foreman has all the resources to get the job done. As shown in Figure 4, the superintendent is on site helping the foreman determine how to place five pieces of stone. There is a difference in the responsibilities of the superintendent regarding the hiring process for union and non-union states. In union states the superintendent is not responsible of hiring workers directly but instead calls the union hall if workers are needed. In non-union states the superintendent is directly responsible of hiring workers. Typically he would call workers that have previously done jobs with the company or he places an advertisement in the news requesting workers.



Figure 4- Superintendent on the site overseeing the installation of stone pieces

In addition to the superintendent, all of the twenty seven respondents pointed out that in each project there is a field superintendent or often times called a foreman. The foreman is the management person on site that supervises workers, plans the work for the day, and coordinates with the other trades the areas where masons are going to work. Respondents also claimed the foreman has to schedule grout and materials, inspect the work, and solve issues that arise on site to make sure the job is completed on time and production is maximized. Figure 1 shows a foreman giving instructions to the forklift operator on how to move around the site.



Figure 5- Foreman (right) giving instructions to the forklift operator

In regards to supervisory tasks, eight respondents from union states claimed that often times (per union regulations) there is a mason foreman or shop mason that works closely with the masons checking that work is going according to plans and making sure they are working at proper times. Four respondents from non-union states claimed they use an assistant foreman when the job has a certain number of masons. The assistant foreman will help the foreman coordinate workers on site and layout the walls. Figure 6a shows an assistant foreman installing a door frame and Figure 6b shows an assistant foreman (left) laying out the chalk lines for a wall with the assistance of a laborer.

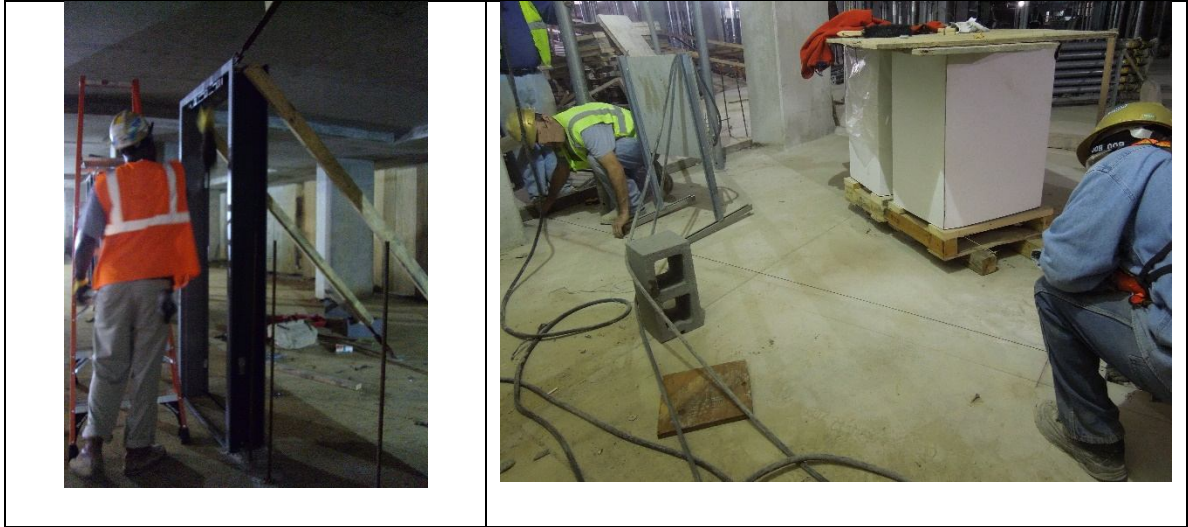

Figure 6a- Assistant foreman assigned to install a door frame; Figure 6b- Assistant foreman (left) laying out a wall with the chalk line

Twelve respondents from union states and non-union states pointed out that there is a labor foreman in the site that works directly with the laborers. The labor foreman may run the equipment (i.e. forklift, crane, and loader) and often times start half an hour earlier to make mortar so that it is ready when the masons get to the site. Similar to the mason foreman, the labor foreman works closely with the laborers checking that work is going according to plans and making sure they are working at proper times. Figure 7 shows a labor foreman (middle) giving instructions to the forklift operator on where to place the boards to build scaffold. The foreman (left) observes.



Figure 7- Labor foreman (middle) giving instructions to the forklift operator

All of the twenty seven respondents highlighted that the masons do the actual installation of the units, that is, masons are the ones that build the walls. There was a clear consensus among respondents that they like to see masons just placing units and laborers doing the rest of the work. Figure 8a and Figure 8b show masons placing masonry units. Figure 8a shows a mason that is starting to build a block wall. The mason is placing units in the area where the wall was laid out. Figure 8b shows a mason that is placing brick on an exterior wall.



Figure 8a- Mason laying block; Figure 8b- Mason laying brick

As for the laborers, all of the twenty seven respondents pointed out that laborers do all the preparation work and support tasks. There were clear references among respondents that even though every laborer that steps in the job site can be a general laborer, some laborers have other skills that will allow them to work in different tasks. A general laborer performs basic tasks such as mixing and hydrating mortar, handling material to the mason, stocking masonry units and mortar boards in the work area, carrying units to the saw for cutting, cleaning the work areas, and grouting the walls. Figure 9a shows a general laborer stocking material next to a wall and Figure 9b shows a laborer grouting a block wall. Then in order of skills, a laborer in the mixer needs to know the ratio of material to make mortar and/or grout (see Figure 9c).

A laborer that builds scaffold needs to know safety rules and be certified to building and dismantling scaffold (see Figure 9d). A laborer in the saw needs to know how to work on the saw and make cuts (see Figure 9e). Finally, a laborer operating the forklift needs a license to operate machines and is the most specialized laborer (see Figure 9f).



Figure 9a- Laborer stocking material next to a wall; Figure 9b- Laborer grouting a block wall; Figure 9c- Laborer making mortar in the mixer; Figure 9d- Laborer building scaffold; Figure 9e- Laborer operating the saw; Figure 9f- Forklift operator carrying material in the site

The one difference came from the saw man since in union states a mason operates the saw whereas in a non-union state a laborer operates the saw. Seven respondents from union states pointed out that any mason can be assigned to the saw. Out of these respondents four claimed they like to switch the mason that is in the saw since the work in the saw is considered less relevant than the actual installation of units. Two respondents pointed out they place the less productive mason in the saw and the fastest in the walls. In one instance a responded said he tries to place the oldest masons in the saw and the youngest in the walls. In two instances respondents claimed that some laborers go to training school to get certified for scaffold building/use, driving the forklift, and signalling.

4.1.1 Summary of the results- Labor requirements

Results from the interviews indicated that there are different roles and tasks in masonry work. The roles presented in Table 2 were identified during the interviews conducted with the practitioners and are complemented with the roles identified in Mitropoulos & Memarian (2013). These roles are primarily for concrete masonry unit (CMU) walls and brick veneer but may likely be different in the construction of other masonry materials such as tile and stone.

As shown in Table 2, eight major roles were identified:

1. The general superintendent is responsible of overlooking the foremen and making sure the projects are performed according to the specifications and the schedule. The general superintendent regularly visits the projects to check on progress and is responsible of staffing, that is, handling personnel and making sure the foreman has the number and type of workers he needs.

2. The foreman, or often called the project superintendent, performs management tasks in a project such as planning the flow of work, distributing tasks, monitoring workers, ordering materials and equipment, quality control, and coordinating working areas with other foremen (e.g. electrical, plumbing, mechanical).
3. The assistant foreman performs management tasks and supervisory work. This assistant foreman supports the main foreman when the number of crews exceeds a certain number or when the crews are spread out in multiple areas.
4. The masons lay units, install rebar and wire for reinforcement (blocks), ties, weep vents, termination bar, flashing, and insulation board (brick), and often times set up door and window frames. Some can read blueprints and have the skills to do wall layout.
5. The general laborers provide support work including mixing mortar in the buckets and delivering mortar to the mortar boards, transporting and stacking the masonry units, erecting and dismantling scaffold and working platforms, grouting, and handling materials to the masons.
6. The saw operator cuts units.
7. The forklift operator delivers materials from the storage areas to the work areas, which include units, scaffold, working platforms, mortar container, and grout container. In projects with small access areas, a warehouse lift is often used in combination with the forklift. In big projects, the number of operators increases with the number of workers and/or the number of floors.
8. The mixer operator mixes grout and/or mortar.

As shown in Table 2, the general superintendent, the project superintendent, and the assistant foreman mainly perform management tasks. On the other side, the tasks of masons and laborers involve the actual construction of the wall. Their work is defined as either productive or support work. The work of masons is considered productive work since they are the ones that are actually placing units in the wall and productivity is measured in units. The work of laborers is considered support work because it is not directly related to productivity, they are not placing units.

The roles defined in Table 2 apply mainly for non-union jobs. For union jobs there are some differences. One difference is that in union jobs a laborer only performs laborer work and masons only perform mason work. In non-union jobs, workers are able to perform in different roles if there is a need for someone to complete a task and the worker has the skills to do so. A second difference is that in union jobs a mason is assigned to the saw whereas in a non-union job a laborer operates the saw. A third difference is that in union jobs the contractor or the superintendent calls the masons union hall for masons and the laborers union hall for laborers. In non-union jobs, the contractor or the superintendent typically have a list of workers that have previously worked with the company. At times of high volume of work, the superintendent places job advertisements in local media stating that masons and/or laborers are needed.

Table 2- Roles

Title	Skill	Role	Task
General superintendent	Superintendent	Plans and allocates field personnel to the project. Oversees the foremen in the jobsite to make sure the projects are going according to the overall plan.	Responsible for staffing
Project superintendent	Foreman	Plans and distributes tasks, monitors workers, orders materials and equipment, performs quality control, lays the walls, and coordinates working areas with other foremen (e.g. electrical, plumbing).	Lays out the wall and designs and allocates crews.
Assistant foreman	Foreman	Plans and distributes tasks, monitors workers, orders materials and equipment.	Supervises workers
Mason	Journeyman	Lay units, installs materials for reinforcement and insulation, set up door frames, marks cuts.	Lays units
	Apprentice	Lay units (learning and getting training on the journeyman level).	Lays units
Laborer	Saw operator	Cuts units.	Cuts units
	Forklift operator	Delivers materials from the storage areas to the work areas which include units, scaffold, working platforms, mortar container, and grout container. In projects with small access areas, a warehouse lift is also used.	Operates the forklift or warehouse forklift
	Mixer operator	Mixes mortar and grout.	Mixes material
	General laborer	Perform support tasks including mixing mortar in the buckets and delivering mortar to the mortar boards, transporting and stacking units, erecting and dismantling scaffold and working platforms, grouting, and handling material for insulation and reinforcement.	Looks over a mason and performs support work

4.2. Rules for crew design

This section focused on investigating and exploring the rules used by practitioners that directly impact labor needs and the size of crews in masonry sites.

Q3: What is a standard crew?

Eighteen respondents said they do not have a standard crew. However, nine respondents did point out that based on experience they have a standard crew or the “most productive” crew they like to use for brick and block jobs. This standard crew works for most of the jobs and if needed, they escalate the crew accordingly with the amount of work to be done. For example, if the job is small they use one standard crew whereas in a big job they will use four or five of the standard crews. Out of these respondents, in five instances respondents said they use a standard crew of one foreman, eight masons, eight tenders, and one forklift operator. In three instances, respondents said a standard crew is one foreman or superintendent, one layout mason (half of the time laying half of the time placing units), one saw man, six masons, six laborers, one labor foreman, one forklift operator, and one mixer operator. In one instance a respondent said he likes to use two types of crews: one foreman, six masons, three laborers, and one forklift operator or one foreman, eight masons, four laborers, and one forklift operator.

Q4: What is the size of a crew?

The overwhelming majority of respondents stated that the size of the crew is determined by the amount of work to be done, that is, by what is required on site. Twenty-five respondents stated that from the estimate they know the quantities of work, that is, the number of masonry units in a job. With this amount of units and the productivity rates they have for their masons, they figure out how many man-days the

job will take. These number of days combined with the owner's number of days will help them determine how many masons (in average) there need to be in the jobsite to complete the job in time.

Six respondents claimed that the number of masons may vary depending on what is happening on site. If ten masons are required every day per the schedule, there could be some days with five masons working and some others with 15 masons working, but in average ten masons are required for the whole duration of the project. As shown in Figure 10, a small interior column needs to be covered with brick. The column is small so the size of this crew is one mason working with one laborer.



Figure 10- Mason working in an interior column.

In further explaining what affects the size of the crew, respondents commented on different factors such as the amount of supervision, the amount of support staff, and the schedule.

Some respondents claimed there are some factors that affect the amount of supervision, that is, the number of foremen or assistant foremen they use, ultimately impacting the size of the crew. Some respondents pointed out that the number of

foremen or assistant foremen depends on the number of masons. In six instances respondents said they typically have a mason foreman for every eight masons and one labor foreman for every eight laborers. In two instances respondents said for big jobs (more than six masons) there is one foreman (non-working) for every six to eight masons and for small jobs (less than six masons) there is one working foreman since there is no much supervision needed. In one instance a respondent said that if there are more than six laborers on site, then one labor foreman is added, who determines where they should be working and maybe operating some machines.

In three instances respondents said that they assign a foreman to the site for every 20 to 25 workers (masons and laborers) and if that number increases then they assign an additional foreman to help. This same respondent pointed out that on significant jobs (more than 20 masons) a foreman for general supervision, a labor foreman to look over the laborers, and a mason foreman to look over the masons need to be used per union regulations. Three more respondents claimed that per union regulations there is a foreman for every four masons but some foremen may be able to supervise four to six masons and even some can handle eight masons so they look at the person per se. Figure 11 shows a crew of three masons and one laborer working on a brick veneer wall. The wall is about 50 ft. long so the size of the crew is three masons and one laborer.



Figure 11- Crew of three masons (top) and one laborer working on a brick veneer wall

Other respondents claimed the amount of supervision depends on the type of job and the job conditions. One respondent pointed out that if the project is a home depot store with 50 workers in a crew then one foreman can handle all since the crew is working in a long straight wall that is compacted in one area, but if the project is a prison or a school and the 50 workers have to be split in five or six crews then there needs to be a foreman for every crew. Two respondents said that on a big wall ten masons are in the same wall and a foreman can handle all, but if the ten masons are in different areas then one foreman is used to look over all the crews and additionally two sub-foremen (assistant foremen) are assigned to manage the individual crews. Two respondents pointed out that in a small crew of about ten to 12 masons in a convenient store there is one foreman supervising, but if the crew is larger (about 30 masons) in a school or big housing complex then one foreman and one sub-foreman are assigned and in some cases even two sub-foremen. One respondent said that if the job is small then there is 1 foreman in the jobsite but if there are about 14 to 16 masons there is a foreman and an assistant foreman.

Five respondents said that a typical foreman takes care of 20 to 30 workers and it will be up to the foreman to determine the maximum number of workers he can handle. Usually they will escalate the number of foreman based on the number of masons. The foreman might call the company and ask for another foreman to help if that maximum number of workers is exceeded.

Some respondents pointed out that in terms of support they follow some standards for the number of support workers they assign to a jobsite. In two instances, respondents said they always have a saw man and typically it is a saw man for every crew of eight masons or a saw man for every two crews depending on the job. In one instance a respondent said he uses a saw man in every job that has less than 15% or less cutting, regardless of the amount of masons and in a job that has 15% or more areas for cutting he uses a saw man for every six masons and then escalates to two saw men if there are more than six masons. Figure 12 shows a crew of two masons and one laborer working on an inclined block wall.



Figure 12- A crew of two masons (front) and one laborer working on a block wall

Some respondents pointed out their preference on the size of the crew. In three instances respondents said that when they have a big crew of ten to 12 masons there needs to be a lot of areas ready so that the crew is not standing and sometimes this is not possible. These respondents emphasized that the interaction with other trades and the setup of the work makes it difficult to have areas ready for that many masons so they prefer a smaller crew of 6 to eight masons, which gives them a better opportunity to reach the production levels. One respondent claimed that the number of masons is determined by how many are needed to keep a constant flow of material to the wall.

In six instances respondents pointed out the schedule also affects the size of the crew. According to these respondents, in an aggressive schedule the site has to have a greater number of masons because they have less time than usual to complete the job and the masonry contractor needs to get it done, but in a flexible schedule not very many masons are needed.

Overall, it was clear for respondents that the size of the crew is determined by the amount of work to be done and also by rules that determine the amount of supervision and support that is needed based on the number of masons.

Q5: How do you build up your crews?

There was a high mark response identifying the fact that crews are build up according to the areas that become available for masonry and the amount of work that is laid for the masons. There were clear references on how the availability of work dictates what areas the crews can work in and consequently if the crew needs to be scaled up or scaled down.

Six respondents emphasized they need to go to the site a week before starting the work to make sure there is enough space or walls ready for the masons to work. Out of these responses, in two instances respondents claimed they like to see about 100 to

200 ft. of wall ready before starting the job and bringing in the crews. Fourteen respondents pointed out that on the first day there is no reason to show up to the jobsite with all the workers since the areas are not ready and the foreman has to coordinate with the other trades the path that is going to be followed on site and where the masonry work is going to start. Out of these responses, in seven instances respondents said that typically on day one the foreman, a mason, and a laborer show up to the site to plan initial conversations with the client, perform some layout, drill the rebar, and check the site. Figure 13 shows an assistant foreman using a laser to lay out a wall.



Figure 13- Foreman using the laser to lay out a wall

Then the next day there is a laborer in the mixer, a couple of masons and a couple of laborers. These respondents emphasized that on the following days after starting a job, the number of masons starts to increase and consequently the number of crews starts to increase. Figure 14 shows a wall that is ready for the masons to work and place units. The rebar is drilled in, block is stocked, and the mortar boards are placed with mortar.



Figure 14- Wall ready for the masons

Once the project progresses, a common opinion among respondents was that there is a need to consider both the number of masons and the walls that are ready to keep up with the schedule. These respondents claimed that the foreman has to look at the schedule and determine what is coming, that is, how much work is going to be ready for the masons. By looking at the areas that become available, the foreman can plan for that variation and either cut the crews or increase the crews.

Fourteen respondents claimed that it is a daily planning so if there are sections ready then more masons are brought to the site and the crews can be increased, whereas if there are not so many areas ready then masons can be moved to another job while some of the areas become available. Figure 15 shows three masons and two laborers working on a section of a wall. The general contractor said to the foreman the area was available for masonry, that is, no other trade was going to work there so the masons were brought to work on this section of wall.



Figure 15- Three masons and two laborers working on a block wall

In ten instances respondents pointed out that it is better if there is a constant number of workers for a longer time, rather than having all those fluctuations of workers and running out of work with a much bigger crew. Out of these respondents, five further commented that a common practice is to hold as much as possible the maximum number of workers for maximum production and then gradually download depending on the amount of work that becomes available. Three respondents claimed that if more masons show up to the site then the foreman tries to make room and accommodate them on site so that they have a place to work.

Finally, when the project is about to end a common opinion among respondents was that they like to have just a few workers on site since there are not many work areas left. Eleven respondents said that typically on the last week or last days, one or two masons and a few laborers are in the job finishing joints to make sure the bonding space is accurate and joints look adequate. In addition, this crew cleans and washes down masonry surfaces to deliver walls according to job site requirements. Out of these respondents, five pointed out that in some cases the foreman stays to supervise and make sure everything is finished according to the requirements but in some cases the

foreman leaves the site to start a new job. Figure 16 shows a mason in an aerial lift brushing the blocks and finishing joints.



Figure 16- Mason cleaning the surface of the blocks and finishing joints

Overall, it was clear for respondents that the crucial task is to gradually build up and build down the manpower and control that variation. Three respondents pointed out that on some jobs there is no staging area so more laborers are needed because every morning they are bringing in material directly from the delivery trucks to the site. In one instance, a respondent pointed out that in the winter season more laborers are needed because there are some enclosures that need to be built and heaters to be tendered. In addition, it was clear for respondents that any time the amount of laborers per mason can be decreased is definitely good for production, that is, have more masons in the jobsite and less laborers.

Q6: How many laborers do you assign to a mason?

The ratio of laborers per mason as an industry standard business practice to determine the amount of support needed was clearly evident in all twenty seven responses. Eighteen respondents stated that a ratio of two masons per one laborer is the most common ratio used in every project. That ratio is the number of masons per general laborer, that is, masons assigned to the laborer that is tending the masons and working on the wall. Note that this ratio does not include the laborers that are used for other support tasks such as the laborer in the mixer, the saw, building scaffold, and the forklift.

These respondents also highlighted that this ratio is an average and that it can increase or decrease depending on the type of project, type of wall, the type of material, and the accessibility in the jobsite. As one respondent pointed out, the ratio was determined in the labor negotiations and it has a range of one mason per one laborer to up to three masons per one laborer in 99% of the jobs. The respondents had several reasons behind these variations.

Five respondents pointed out the differences in terms of the type of project. A project that is a "box" such as a Wal-Mart or Target store typically has long straight walls that go fast so they have two masons per one laborer or even one mason per one laborer. In other projects that have more openings and small walls such as a prison or high school, they have two masons per one laborer because the walls do not go as fast so not many laborers are needed to stock and handle material. In other projects such as a bank, court house, or federal building they have two masons per one laborer or even three masons per one laborer because the walls go very slow (require a high level of cuts, details and precision) so one laborer can take care of three masons. Figure 17a and 17b show three masons and one laborer working on a block wall that requires

working around pipes and cutting block. Since the work is slow, only one laborer is assigned to tend the masons.

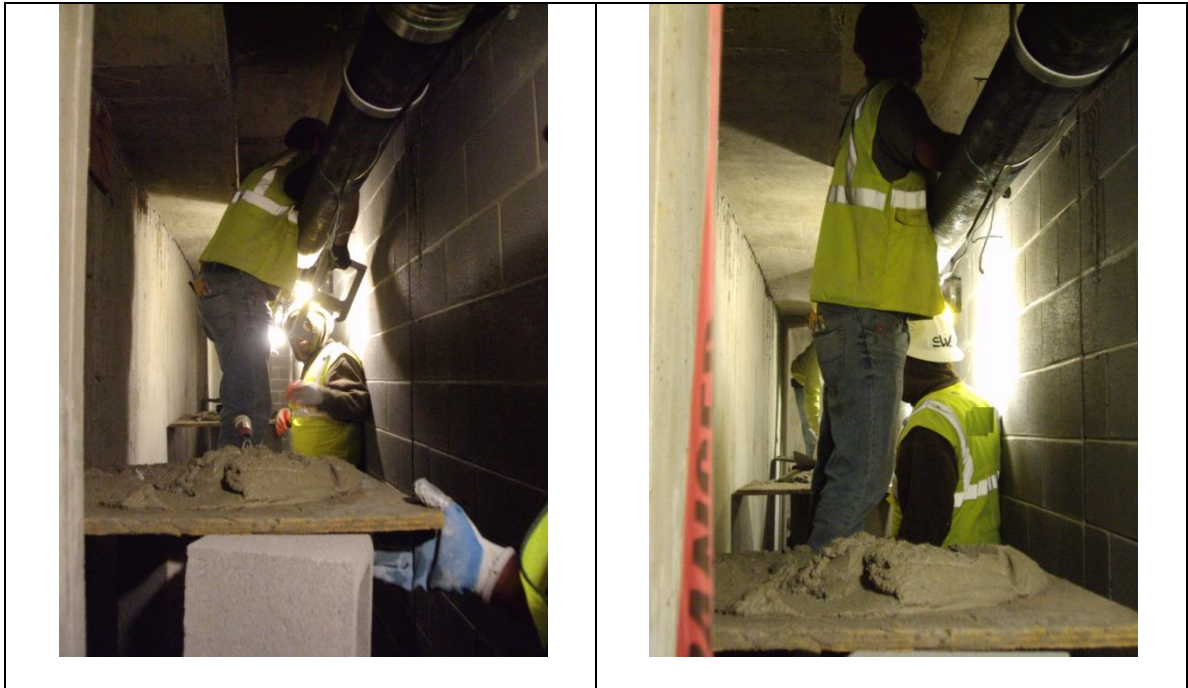

Figure 17a, 17b- Three masons working on a block wall that requires cutting around pipes on a very narrow area. One laborer is tending the masons.

Some respondents highlighted that the type of material is also determinant to the number of laborers per mason. In seven instances respondents commented that load bearing walls such as block walls require more laborers because these walls require grouting, there is more material that goes in the wall (reinforcement and steel) and the speed of the wall is fast (big units cover more area). On the other hand, as stated by these seven respondents, brick veneer walls require fewer laborers because there is no grouting, less material goes in the wall, and the speed is low (smaller units cover less area). Additionally, brick usually goes on the outside of a building so accessibility at the site is not a factor, materials can be handled directly which takes fewer laborers to move

material around. Figures 18a and 18b show the hole in a basement that was used to bring in material to the jobsite. A crane was used to lift a metallic cage with the blocks.



Figure 18a, 18b- Crane used to lift a metallic cage with blocks

Some respondents pointed out the type of wall also affect the number of laborers. Fourteen respondents highlighted that long straight walls that have no openings and intricate work go pretty fast so in these walls there needs to be one laborer for every two masons or even one laborer for every one mason while on walls that do have openings or intricate work there needs to be one laborer for every two masons or even one laborer for every three masons. Figure 19 shows a straight wall in which one laborer is assigned to two masons. The masons are placing units (left) and the laborer is stocking units in the scaffold (right).



Figure 19- Long straight block wall with two masons (left) and one laborer

In six instances respondents pointed out that a given wall section would require less laborers than that same section broken into different smaller sections that are spread apart because laborers cannot be all over the place running up and down. For these respondents, even if the section is small, there needs to be a laborer handling material and looking over the mason, so there is a laborer in each and every section regardless of the size. Figure 20 shows a mason and a laborer working on a short wall. Even though the wall is short, a laborer has to be tending the mason and bringing in material for the mason to build the wall.



Figure 20- Mason and laborer working on a short block wall

In five instances, respondents pointed out the accessibility at the jobsite could increase the number of laborers since in tight spots or spots that are hard to reach with the forklift more laborers are needed to bring and handle material to the masons. For example, a pair of laborers carrying a mortar bucket or two with their hands and a wheelbarrow filled with masonry units are a replacement for the forklift. As shown in Figure 21, a wheel barrel is used to bring material to the work area since the concrete poles make it impossible to use the forklift to carry material.



Figure 21- Two laborers carrying block on a wheel barrel and stocking units in the work area.

In four instances, respondents pointed out high walls require more laborers because there is scaffold and more laborers help is needed to handle material in the scaffold to the masons and take care of the masons. Five respondents emphasized the amount of scaffold and type of scaffold also affected the number of laborers. Figure 22 shows an area of the site where there is a good amount of scaffold built.



Figure 22- Scaffold to build a long straight wall

According to these respondents, while more laborers building scaffold are needed if there is a good amount of scaffold in the site, less laborers are needed if a hydraulic scaffold is used instead of the regular type of scaffold because the hydraulic scaffold does not require manual installation. Figure 23a shows a hydraulic scaffold that is used to build a brick veneer wall section. The scaffold covers the entire wall so no scaffold building is needed (see Figure 23b). The platform of the scaffold moves vertically to the brick course where the masons are laying units.

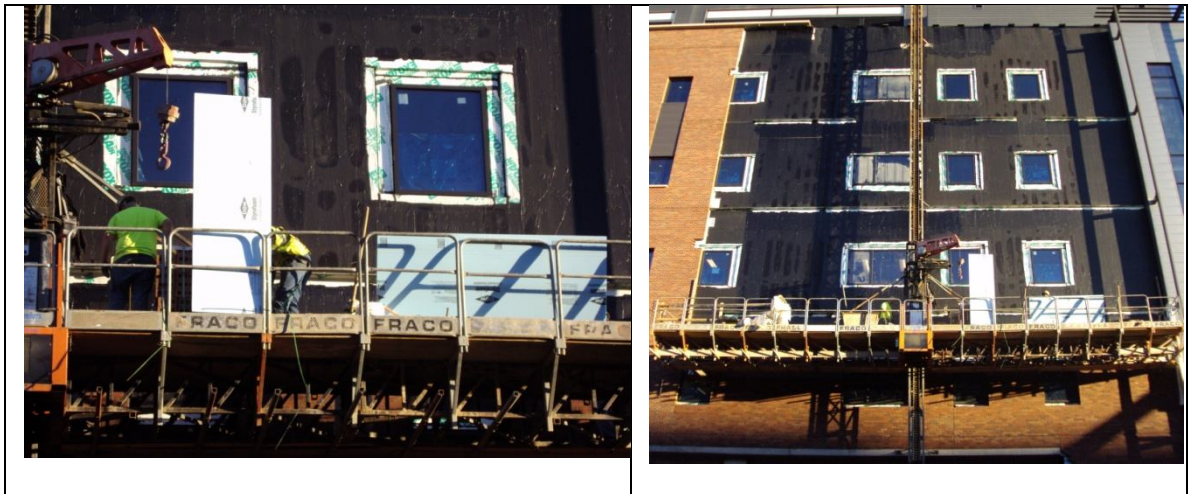

Figure 23a and 23b- Hydraulic scaffold is used to build a brick veneer wall

Three respondents pointed out that on some jobs there is no staging area so more laborers are needed because every morning they are bringing in material directly from the delivery trucks to the site. In one instance, a respondent pointed out that in the winter season more laborers are needed because there are some enclosures that need to be built and heaters to be tendered. Overall, it was clear for respondents that any time the amount of laborers per mason can be decreased is definitely good for production, that is, have more masons in the jobsite and less laborers.

Q7: How do you determine the number of masons per wall?

All of the twenty seven respondents mentioned the size of the wall as a factor to determine the number of masons per wall. Twenty-three of the respondents stated that 15 to 20 linear ft. of wall was the minimum space they assigned to a mason to guarantee the mason had enough room to stretch out, spread mortar, and avoid bouncing into another mason's shoulder. The respondents had several reasons behind the rationale for using those minimum 15 to 20 linear ft. of wall. Six respondents emphasized that by giving the mason that minimum amount of linear feet of wall, the mason implicitly knew he had that much to lay, and at the end of the day they could easily get their count in a wall section. Figure 24 shows a block wall that is about 24 ft. long. Two masons are on top of the scaffold working on this wall and one laborer is tending the masons.

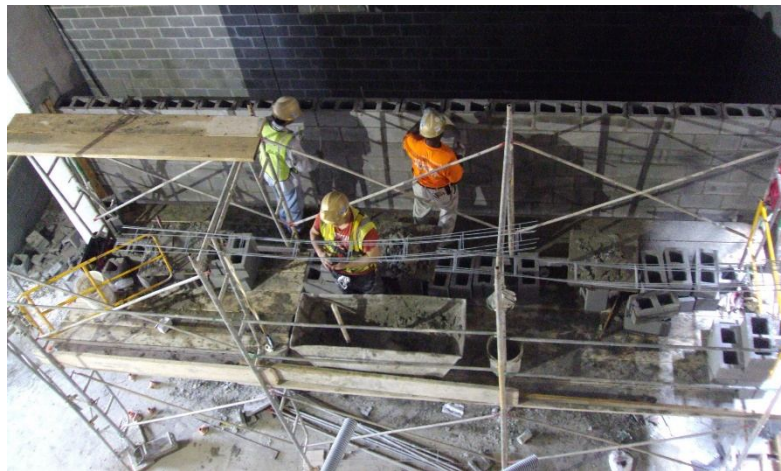

Figure 24- Two masons working on a 24 ft. block wall

Five respondents highlighted the fact that a smaller section of wall would require frequently raising the line and thus more time wasted than getting units in the wall. Four pointed out that 15 ft. was a good space for setting up the pace and that a smaller

distance would result in less time for the masons to keep up the pace and more time waiting to raise the line. In six instances, respondents highlighted that 15 to 20 ft. of wall per mason allowed them some flexibility to accommodate more masons in case an area was not ready for a mason to work. As stated by these respondents, sometimes they will put a mason in between two other masons just to give that mason a place to work and that could only be done if they had accounted for 15 ft. of wall per mason. One respondent emphasized that if the space was longer, by the time the mason comes back to the mortar board the mortar might need to be re-tempered, increasing the number of laborers needed, which is not desired. Overall, it was clear for respondents that too many masons is not always productive, since the more you start to crowd people the less efficient they are going to be. Figure 25 shows a brick veneer wall that is about 25 ft. long. Two masons are working on this wall and one laborer is tending the masons.

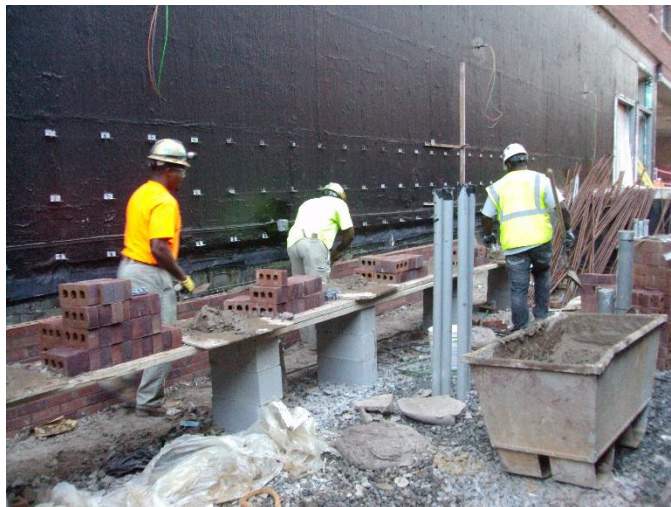

Figure 25- Two masons working on a 25 ft. long brick veneer wall (two left)

Some respondents pointed out that in addition to the size of the wall, there are other factors that affect the number of masons. In eight instances respondents pointed out that the number of masons is also affected by the type of wall. While a long straight

wall, a “money wall” would require a high number of masons because it goes fast, a wall with openings and penetrations would require fewer masons because is not going to go as fast. Figure 26 shows an L-shaped block wall with three masons and two laborers. The longest side is about 21 ft. long and the short side is about 16 ft. long. There is a door frame in the short side of the wall.



Figure 26- Four masons (and laborer) on an L-shaped block wall

Three respondents pointed out the linear feet per mason could change if a masonry unit needs to be handled by two masons (a heavy unit), reducing the minimum space of wall for two masons instead of one. Four respondents claimed that the number of masons also is driven by the schedule since in a fast schedule more masons need to be working compared to a normal schedule were the number of masons is driven by the size of the walls. In nine instances, respondents pointed out that if a wall has many corners and needs more precision work, then that wall may require one or two more masons and then is not 15 linear feet but can be 10 linear feet per mason. As these respondents said, a mason will be in each corner setting up the string line and raising the line once each course is finished. In one instance, a respondent claimed that he also

considers the amount of closure points as a factor to determine the amount of masons in a wall. By minimizing the number of closure points or the number of points where two masons meet, low productivity sections were decreased.

Overall, it was clear for respondents that the length of the wall is the factor that determines the number of masons.

4.2.1 Summary of the results- Rules for crew design

Superintendents start the staffing process at the macro level to determine the number and type of workers needed in a project. Although, the size of the project and the availability of masonry work play an important role in defining labor requirements, there are some rules that contractors use and try to maintain and that may or may not be affected by the size of the project. These rules, which are the result of years of experience, impact the labor requirements and ultimately help superintendents and contractors determine the number and type of workers per project and the composition of the crews. The rules presented in this study were determined from the interviews with masonry practitioners and are coupled with the rules identified in Hassanein and Melin (1997).

Rule 1: Crew composition

In general contractors do not have a typical crew, but they have some guidelines as to the worker's ratio in a crew that they use and try to maintain. This ratio dictates the typical number of laborers to masons that is used when forming crews.

Rule 2: Crew operators

There are some basic operators that need to be present in the jobsite at all times. No matter how many crews are present, there always has to be a laborer mixing the mortar, a laborer in the saw, and a laborer operating the forklift.

Rule 3: Forklift operator

The forklift can only handle a maximum number of crews (in terms of material per day). When the maximum number of crews is reached, then it is necessary to assign another forklift and thus a forklift operator.

Rule 4: Saw operator

Typically the foreman uses one saw operator in the job to handle the cuts. However, when there are walls with a lot of openings or masons need to work around a lot of pipes and ductwork, the foreman has a saw operator for every number of workers to keep up with the high amount of cuts.

Note: in union jobs a mason works in the saw. It can be an apprentice or a journeyman level mason.

Rule 5: Starting crew

The initial plan considers that there is not a full crew when a job starts. Typically during the first few days, the foreman is in the jobsite with a mason and a laborer. This small size crew makes sure the structure is ready for masonry and starts figuring out the workflow of activities. Furthermore, this small crew starts laying out the walls, stocking material, and setting up the walls so when the masons get to the site they can immediately start placing units in the walls (Hassanein and Melin, 1997).

Rule 6: Closing crew

When the job is about to finish and there are not many work areas left, there is also a small size crew. Typically composed by one or two masons and a few laborers, this small crew tools and finishes joints to make sure the bonding space is accurate and joints look adequate. In addition, the crew rubs, cleans and washes down masonry surfaces, and removes tags scrapes and excess mortar to deliver walls according to job site requirements (Hassanein and Melin, 1997).

Rule 7: Crew size

In regards to the crew size, there are a maximum number of workers that are assigned to a non-working foreman. Typically foremen or in some cases the contractor determine the maximum number of workers that they can handle to guarantee an adequate control.

Note: non-working implies the foreman is not working with his tools in his hands, that is, the foreman does not place masonry units in the wall.

Note: In different jurisdictions the union contractors per the collective bargain in that area may specify the number of masons a foreman can handle. This foreman is often called mason foreman or simply foreman.

Rule 8: Crew control

The foreman has a working assistant foreman that monitors crews and helps layout the job. The number of assistant foremen or often times called mason foreman is dictated by the foreman and depends on the number of crews. Usually the number of crews is divided equally among the assistant foremen

Note: union contractors need to have a labor foreman per a given number of laborers and an assistant foreman per a given number of masons. These foremen (for laborers and masons) help supervise crews and coordinate work before actually doing it and are different people since the union hall for laborers is separate from the union hall for masons.

Rule 9: Masons per wall

In general foremen do not have a rule to determine the number of masons per wall, but they use the length of the wall as a guide to build up their crews. Typically foremen assign a mason every given linear feet of wall. This length of wall gives the mason enough space to spread out and keeps the mason busy and productive all day. If the

masons are too tight, the production decreases because the wall is crowded and masons don't have enough space to spread mortar freely.

Rule 10: Accessibility

In general, the number of laborers will increase if the accessibility around the jobsite is difficult. Usually if walls are located in areas that are inside the building where it is not possible to reach with the forklift, more laborers have to be assigned to bring material and pack material for the masons to work.

4.3. Drivers for crew makeup

This section was designed to explore criteria used by practitioners in making up crews. It openly examined the guidelines that practitioners use to form efficient and productive crews.

Q10: What factors do you consider when grouping masons in crews?

The overwhelming majority of respondents stated that there is always a rationale in picking up masons in the process of forming crews. Twenty-one respondents highlighted the fact that masons have different personalities and consequently some masons work well together, but some masons just do not work well with certain other masons. These respondents recognized the importance of teaming up people that like each other as determinant for productivity and a good work environment. Figure 27a, Figure 27b, and Figure 27c show two masons assigned repeatedly to work together in different walls since they worked well together and liked each other.



Figures 27a, 27b, 27c,- Masons assigned repeatedly to work together in different wall sections

Some of these respondents further explained how the personality of the masons influenced decisions on site. Four respondents pointed out the foreman may request workers that he really likes to work with and keep them in his team. Five respondents claimed they mix masons around during the first weeks as a way to determine how they work together and then group them in the most productive arrangement based on their personalities. Two respondents pointed out that it was a good practice to group masons that have the same ideas and have the same work ethic. One respondent claimed that there has to be a bonding between the masons and masons need to communicate well.

Another common practice pointed out by respondents is to evenly spread the most productive masons across the projects. Eleven respondents claimed to mix the most productive masons with the less productive masons. Eight respondents claimed this helped to balance production (overall the projects), while three claimed the less productive will be pushed by the most productive masons since masons like to compete and take a lot of pride in their work.

Another practice is to mix apprentice level masons with journeyman level masons. Ten respondents claimed to do this, so that the journeyman (experienced mason) can show the apprentice how to perform work. Out of these respondents, five claimed they mix journeyman and apprentice because this practice helps train new masons to enter the trade while five claimed there are some industry guidelines as to the ratio of apprentice to journeyman in a crew that they have to use per union/state regulations.

In three instances, respondents claimed that it was a good practice to have a left-handed mason with a right-handed mason so that both masons could place units going forward instead of having one mason having to work backwards. In one instance, a respondent claimed that he tries not to pair a tall mason with a short mason because they have to work at the same level and to the line and by the time the short mason needs a scaffold build the high mason can still reach out the wall.

Overall, it was clear for respondents that masons work in crews so crews have to be assembled in order to have a good work environment.

Q11: If you have different wall sections, which worker goes to which wall?

The overwhelming majority of respondents clearly stated that there is a whole spectrum of masons with several different characteristics, and that there is a place in the site for each and every mason. Twenty five respondents were in the opinion that the

foreman or superintendent on the jobsite has to know the capabilities of its manpower in order to better use their strengths. It was a consensus that the initial step to getting to know how experienced and skilled a mason is when it gets to the jobsite, is by looking at the way the mason picks up the trowel and spreads mortar.

The second step to getting to know more specific skills is by looking at the way the mason marks the cuts for an electric box. Figure 28a and 28b show an experienced mason measuring a block and marking the cuts for an electric box. While a mason that is good at detailed work will rapidly figure out and mark the cuts, a mason that is not good with detailed work (but probably good with the string line) will take time figuring the marks and will slow down the work. Figure 29a and 29b shows the string line used to lay units in a wall, which does not require a mason to level and plumb a wall. In general, respondents recognized that with time they start getting to know their workers and their characteristics based on past performance and use this information to better plan work.

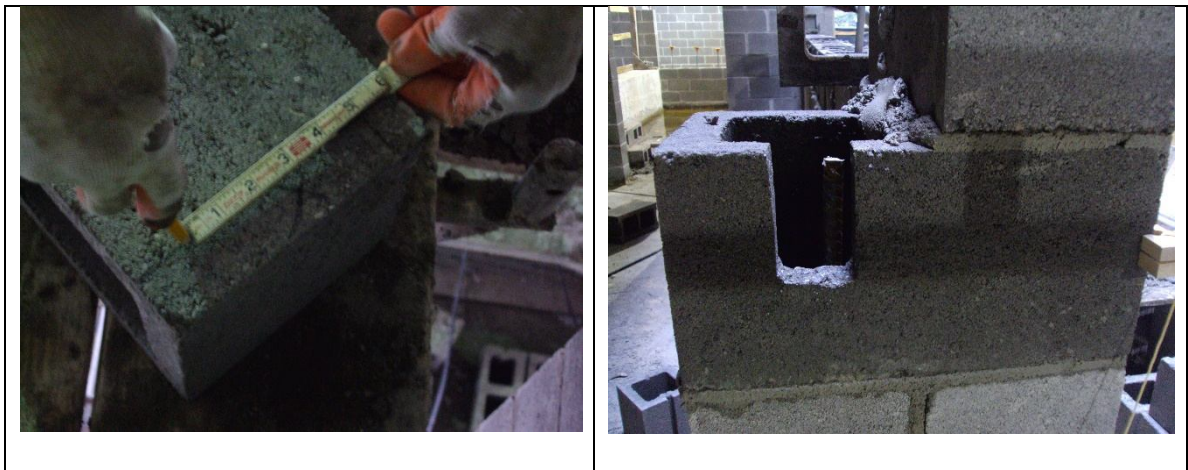

Figure 28a, 28b- Mason measuring and marking the cuts for an electric box

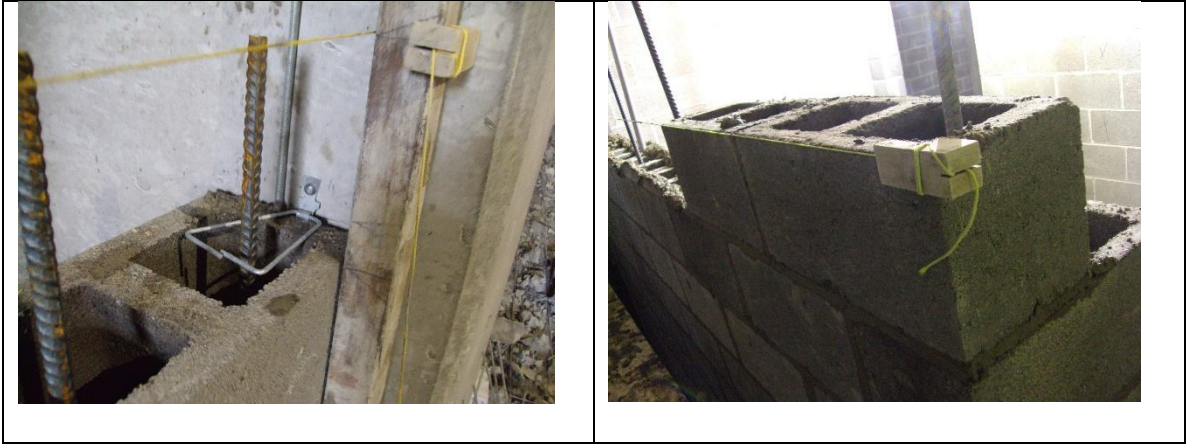

Figure 29a, 29b- String line used to lay masonry units

Twenty-one respondents pointed out that some masons are very good with the level and plumb so they work well on wall sections that require a high demand of craft work such as walls with openings, windows, building leads, complex patters, and arches. As shown in Figure 30a, one mason is using the level on a section that requires levelling and plumbing. Figure 30b shows one mason working on a wall with numerous windows.



Figure 30a- Mason using the level to build a block wall; Figure 30b – Mason working on a wall with numerous windows

Eighteen respondents claimed that some other masons are not good with the level and the plumb but are very fast so they work on wall sections that do not involve craft work. Figure 31 shows a mason that is good working in the line and is very fast so he is assigned to a long straight block wall that has not detailed work.



Figure 31- Mason working on a long straight block wall

Six respondents claimed they place the highest quality masons on visible spots such as entrances, high traffic corridors, painted walls, and exterior walls and the not so quality masons on interior walls, walls that may be covered with sheet rock, and high walls that are not visible. Figure 32a shows a mason working on an exterior wall that requires high quality work. The wall has some insertion brick courses and some courses with color brick and patterns (see Figure 32b).



Figure 32a- Mason working on a high quality brick veneer wall; Figure 32b- High quality wall with insertions and color brick

Twelve respondents recognized that masons have different skill levels, and this fact influences the location where each mason can work. While journeyman level masons have more experience and can be assigned to any spot on the job, apprentice level masons have less experience and need to be assigned to wall sections that do not require a high level of skills.

Another common factor when assigning workers to walls highlighted by respondents is the trade of the masons. In twelve instances respondents pointed out that even though masons learn how to lay brick and block, the most common masonry units, some are better at laying brick and some are better at laying block, so they place the masons according to the trade they perform better. Respondents claimed that bricklayers look into details and can easily manipulate light units whereas block masons are less into details and can manipulate heavy units. Figure 33 shows two experienced masons working on a brick veneer wall. One respondent claimed that he prefers to assign a young mason to a block wall because he can lift heavier units whereas an old mason will be assigned to a brick wall because the units are lighter.



Figure 33- Masons putting the pole line in a brick veneer wall

In six instances respondents pointed out that if a new mason comes to the site, they try to place the mason in different spots to determine its capabilities. However, as mentioned by these respondents, they usually prefer to have masons they have worked with before because they know what their skill level is and where to best place the mason in the jobsite to maximize production.

Five respondents claimed they try to keep the masons in a wall until the wall is finished since they are familiar with the work, know the elements that go in the wall, know the measurements, and most likely they will do the work right. In two instances, respondents claimed they have specific masons building the leads because they are good with the level. These masons start a wall to establish the bond and the pattern and once they build the leads the masons that are good with the line come and just fill the wall. Figure 34 shows a mason building the lead in a block wall.



Figure 34 –Mason building the lead in a block wall

In one instance, a respondent claimed that some masons are afraid of heights so he tries not to place them on very high walls.

Overall, it was clear for respondents that one of the factors for productivity is how to best apply and use the skills of the masons. In other words, recognize that masons have strengths and weaknesses and consciously assign masons to walls according to their abilities since there is always a different skill needed for each wall.

4.3.1 Summary of the results- Drivers for crew makeup

Results from the interviews indicated that there are different qualifications of masons that are determinant in how crews are designed. Masons use masonry units to build schools, prisons, warehouses and other structures. Most masons learn the trade through an apprenticeship program, but some learn directly on the job. Even though a mason may have all the qualifications to build a masonry structure and perform tasks, most of the times they are better at doing some tasks than others. In other words masons get very specific in what they can and cannot do. Not all of the qualifications of masons are

equal and it is something that needs to be considered when planning a masonry project. The qualifications of masons presented in this study are based on the responses of the interviews given by the masonry practitioners:

1. Suitability:

- Non-detailed: mason that is fast working in the line and filling the wall.
- Detailed: mason that is good at leveling and plumbing and therefore works in wall sections that require a high demand of craft work and technical work (e.g., openings, intricate corners, details, building leads, penetrations).

2. Craft:

- Brick: a mason that is more suited to working with brick (bricklayer)
- Block: a mason that is more suited to working with block (block mason)

3. Compatibility:

- Compatibility: masons have personalities that impact the way they perform on crews.

4.3.2 Proposed drivers for making up crews

Analysis of the interviews revealed several criteria for the makeup of crews. These criteria are used by masonry practitioners in designing crews and are used as guidelines when the foreman or superintendent is in the jobsite and is trying to group workers in crews to form the most efficient crew. There are 3 drivers for the makeup of crews:

Driver 1: Compatibility of labor

Masons have different personalities, ways to work, and get things done. Some masons work well together, but some masons just do not work well with certain other masons. They just do not get along and when they work with each other they seem to get less productive. This often creates a friction on the wall and can bring the whole crew down. The foreman tries to form crews with workers that are compatible because grouping masons that work well together can improve quality and increase throughput (Kumar et al, 2013).

Driver 2: Suitability

Masons have different specialties and can be more suitable to work in a specific type of wall. Some masons are very good levelling and plumbing and therefore are fast (and efficient) working on wall sections that require a high demand of craft work and technical work (e.g., openings, intricate corners, details, building leads, penetrations). Other masons are not good with the level and the plumb but are very fast (and efficient) working in the line and filling the wall. These masons can be assigned to non-craft work (e.g. straight walls or walls with little to no openings) because they are good at laying units to a line. The superintendent tries to assign a mason to a wall that matches the specialty of the mason to the type of work required in the wall.

Driver 3: Craft

Most masons learn (and know) how to lay brick and block but are usually faster at one craft than the other. Some masons are good at handling smaller units and are more detailed so they are better brick layers, whether some masons are stronger and are better at laying block. In other words, in masonry there are bricklayers and there are

block masons. The superintendent tries to assign a mason to a wall section where the material match the craft the mason is faster at and thus more efficient at.

4.3.3 Wall degree of difficulty

A number of trades in construction use up-to-date information in labor references to estimate the labor time and value of an installation. These references list national averages for the construction industry, helping estimators build competitive estimates and giving estimators a consistency to their estimates (RSMeans, 2014). One of such references is the RSMeans manual, which offers a comprehensive cost database for the construction industry. In addition to RSMeans, other reference manuals have been developed to specifically support construction trades such as Timberline, and the Manual of Labor Units for electrical construction.

The Manual of Labor Units published by the National Electrical Contractors Association (NECA) is one of the most detailed and comprehensive labor-units manual in construction (NECA, 2014). This manual lists the national average direct labor time required to install electrical materials and components based on three degrees of difficulty: normal, difficult, and most difficult. These degrees are used for determining the labor-unit value for a specific project by considering both the job's and installation's degree of difficulty (NECA, 2014). The job's degree of difficulty takes into account the type of project and the working conditions. For instance, the NECA suggests to use labor unit "normal" for residential (e.g. apartment buildings, high-end homes) and commercial construction (e.g. office buildings, store malls), "difficult" for institutional construction (e.g. hospitals, schools), and "most difficult" for special projects (e.g. water treatment plants, mines). Considering that these jobs have a set of individual characteristics, the installation's degree of difficulty further helps establish a labor category for the different areas a project might have. The installation's degree of difficulty considers factors such

as mounting elevations, weight, occupancy, and duplication. Mounting elevations takes into consideration ceiling heights and the floors of a building as these may require the use of special scaffolding and lift rental charges. Equipment weight and occupancy are also considered since an increase in any of these requires more installation time and precaution. Duplication or multiple installations of like products on the other hand, reduces the labor unit. Weather, which cannot be analyzed from labor unit tables, is usually appraised based on training and experience.

Although NECA acknowledges that it is impossible to relate all the influences that affect labor units, these factors serve to more closely reflect the individual job characteristics that may affect a labor unit. The NECA labor-units, which are periodically updated, serve as a benchmark of the electrical construction industry (NECA, 2014). With this standard set of labor-unit values, electrical contractors and more specifically estimators can have a consistency in the estimates. In a similar manner to the characterization used in NECA, this study proposes a system to categorize masonry walls using a three degree system. With such a categorical system, the wall's degree of difficulty may help determine the total number of workers, the type of workers and the skills of the workers required to build a wall. By characterizing the walls, the estimating and the planning process could be facilitated since this standard could help masonry contractors determine the influences in labor for different wall types and project types and better anticipate the needs to complete a project. The proposed two degree wall characterization for masonry is as follows:

Easy/normal:

It is a straight wall that has no openings or details and it is just a long wall or a line and a wall that might have a few openings such as door or window frames and intricate for ductwork. The spacing between the openings can be about 15-20 ft. There is no difficulty

in that wall so it is the highest productive and fastest wall in a project (see Figure 35). This is the most common type of wall in a masonry project (see Figure 36 and Figure 37).



Figure 35- Easy/normal wall

An easy wall is a fast productive wall. Therefore, the highest productivity rates are expected for this type of walls. The foreman might want to assign the fastest masons (as opposed to quality masons) to this wall to get a high production.



Figure 36- Easy/Normal wall

Every mason on a project should be able to work on a normal wall. Therefore, the foreman might assign a mason no matter the skills (apprentice or journeyman) and no matter the capabilities (high quality mason) to a normal wall.



Figure 37- Easy/normal wall

Difficult

A wall that has mostly detailed and technical work such as openings, intricate corners, and penetrations. This type of wall may involve building arches, piers, and columns (see Figure 38 and Figure 39). A difficult wall has to be constantly leveled and plumbed. Because of its shape and the amount of openings it has, it cannot be constructed using a string line. Most of the time, the masons have to work with their plumb rule and level. This type of wall is very slow in terms of production (see Figure 38 and Figure 39).



Figure 38- Difficult wall

In this case the foreman does not look for productive masons but for the highest quality masons, that is, masons that are better with detailed and technical work since more expertise is needed. In a difficult wall, the masons are spending more time with the plumb rule and the level and they are not getting as much production. Also the masons might be working with masonry materials with special characteristics such as different surfaces or color units that may require blueprint reading and more skilled masons. Therefore, not as much labor is needed to take care of those masons.



Figure 39- Difficult wall

4.4 Discussion chapter 4

In this chapter, a detailed summary of the twenty-seven responses to the questions of the interview protocol was conducted. To detail masonry realities, three sections, namely labor requirements, rules for crew design, and drivers for crew were summarized. The responses to the questions were explained and photos were added to visually help the reader understand the conditions of the site, that is, illustrate masonry site realities. The realities will give a basis for the decision support system (DSS).

CHAPTER 5

DECISION SUPPORT SYSTEM

Masonry construction is labor-intensive. Processes involve little to no mechanization and require a large number of crews made up of masons with diverse skills, capabilities, and personalities. Tasks may require several crews to complete different functions, and crews need to be scheduled to ensure an efficient output and adequate control (Hassanein & Melin, 1997). Consequently, masonry contractors need to consider the conditions of the site and the masons' characteristics that are required to complete the work within the given time and quality constraints.

Crew scheduling in masonry construction is the process of configuring crews and allocating crews to the different tasks. This scheduling process in masonry is challenging. Often crews complete their work on a wall section and then have to be relocated to complete another part of a section. Due to this characteristic, every time a wall section or part of a wall section is completed, the labor configuration is reorganized. This results in temporary crews that need to be constantly moving, and the superintendent in the site is responsible of re-configuring crews and scheduling the crews so that the project is completed within the given constraints. Therefore, effectively allocating masons based on their functions and characteristics make labor planning crucial for the success of a masonry project for the contractor and the owner.

Crew scheduling in a masonry site is typically done as described below. Every week, the project superintendent, often simply called the foreman, determines the walls that are going to be built based on the areas that are available for the masonry work specified by the general contractor. Once the walls are established, the superintendent determines the number of masons that are needed to complete the walls considering the

man-hour needs specified in the estimate, the size of the walls, and the workload. After the number of masons is established, the superintendent determines which masons are going to be grouped in a crew to work on each wall or wall section. When the crew finishes building a wall, the superintendent either assigns the crew to a different wall or re-configures a crew and assigns the new crew to another wall. Every time a wall is finished, the superintendent is responsible of rearranging the crews (if necessary) and reassigning crews to the different walls. This crew makeup and assignment process continues for the whole duration of the project. In other words, every week the superintendent plans the labor requirements for a project based on the areas that are available for the masonry work.

Figure 40 illustrates the current allocation method for one week. On that week, two walls are available for crews to work, section 1 and section 2. The superintendent has determined the number of masons that are needed to build the walls based on the size of the walls and his experience with previous work. Section 1 is a block wall and needs four masons (indicated by the red crosses), and section 2 is a brick wall and needs three masons. There are 7 masons available that week to complete the work. Each mason has different capabilities, skills and personalities. For instance, mason 7 is a mason that is better at laying block than brick, is very good with detailed work, and gets along well with mason 1, mason 3, and mason 4. Therefore, mason 7 can be assigned to either section 1 or section 2. The superintendent then needs to determine for mason 7, as well as for the other masons, who will go to which crew and to which wall.

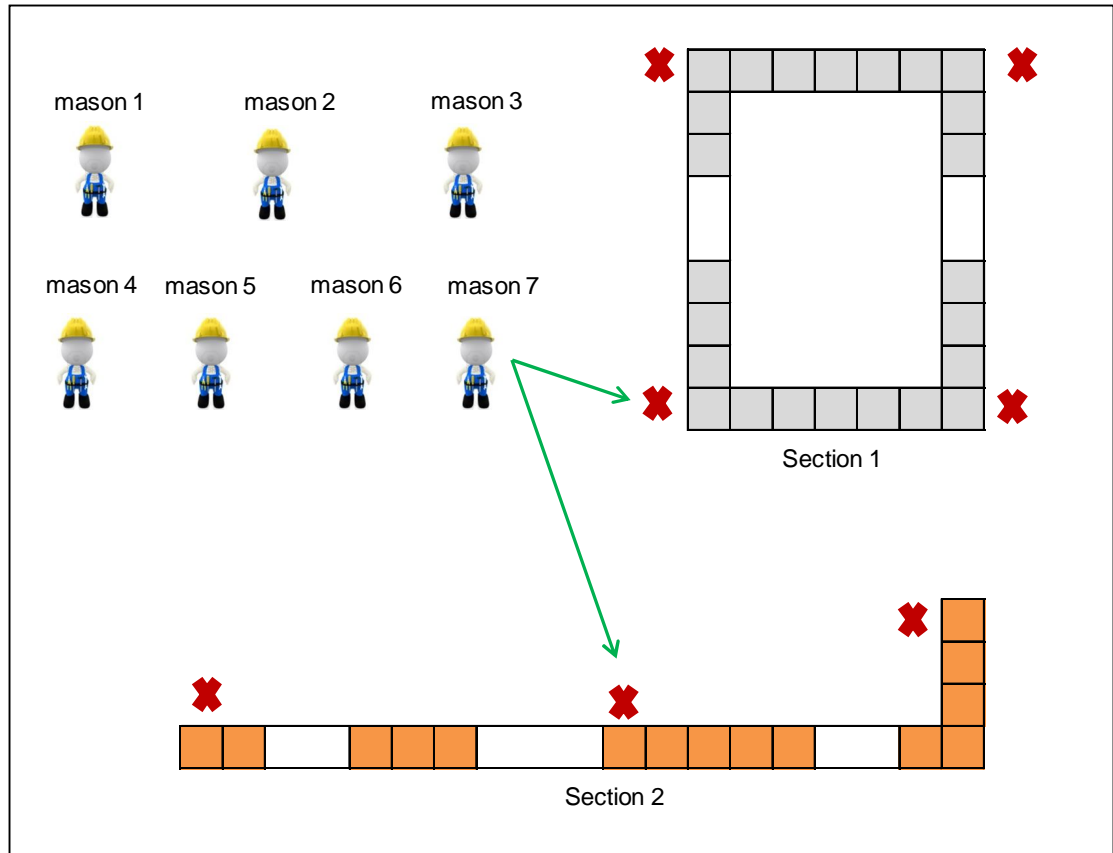

Figure 40- Labor allocation for one week

That is, the superintendent is responsible for forming crews of masons and assigning crews to the two sections to balance between the complexity of the job, the need for quality, and the need for high production rates. However, increase of workflow, quality of work, and worker's well-being will not be achieved if the characteristics and functions of the masons, the interactions between the masons, and the site characteristics are not fully considered when configuring and assigning crews to the different walls.

To address this problem, this document presents the masonry construction industry with a DSS designed to facilitate the crew makeup and allocation process. Specifically, the system integrates the rules that contractors use to design crews with the drivers for making up crews to balance production and quality in masonry sites.

5.1 Problem definition

The crew allocation problem faced by masonry contractors has the following key characteristics. First, the masonry walls that can be built during each period of time are determined by the areas that are available for the masons to work in. In other words, the masonry contractor knows which walls or sections of wall can be built. Second, the superintendent and the contractor have determined the order to build the walls that are available, that is, they have established the precedence relations between the walls to avoid blocking access to get equipment and material. Third, the geometry and physical characteristics of each wall are known in advance from the drawings and specifications of the project. Fourth, the superintendent and the contractor have determined the number of masons that are needed to build a specific wall based on industry standards and previous work. Fifth, the superintendent can build as many walls as needed to complete the work per the schedule as long as there are masons available to work on each wall. Lastly, all masons have been ranked by the superintendent based on the suitability to work in a specific type of wall, the experience with a certain craft, and the compatibility with other masons.

The process starts when the general superintendent and the foreman for the project establish the number of masons that are needed based on the man-hour needs specified in the estimate and also the areas that are available for the masonry work. In other words, at the macro level the main purpose is to determine the number of masons for each project. However, masons have different personalities, capabilities, and skills, and not every mason can be assigned to every wall and every crew. Currently, masonry contractors and superintendents are aware that masons have different characteristics and functions. It is still common practice for contractors and superintendents to know the characteristics of their masons "in their head". In other cases, contractors and

superintendents have a rating system to rank their masons, but only some characteristics are considered when assigning masons to the different walls in a project. Consequently, increase of workflow, quality of work, and workers' well-being will not be achieved if the complexities of the workforce, the characteristics of the site, and the subjective and social interactions between masons are not fully considered during the staffing process.

5.2 Literature review

Human resource allocation is the process of assigning crews of workers to tasks (Lin, 2011). Tasks may require several crews with diverse functions to be completed and crews need to be scheduled to ensure an efficient output and adequate control (Hassanein & Melin, 1997).

Implementation of crew scheduling and allocation problems in construction has been reported in the literature. For instance, Al-Bazi and Dawood (2010) present a strategy to allocate crews of workers in the precast concrete industry using genetic algorithms-based simulation modeling. Their crew allocation system efficiently allocates possible crews of workers using two steps: process mapping to identify, model, and simulate the processes and a genetic algorithm approach to search for a more promising allocation. Lin (2011) proposes a decision-making model for human resource allocation in remote construction projects. Their approach balances management expenses and project risks while considering strategies between assigning regular staff and hiring local temporary employees. El-Rayes and Moselhi (2001) develop an optimization model that uses dynamic programming for repetitive construction projects such as highways, high-rise buildings, and housing projects. Their approach incorporates scheduling and interruption algorithms to identify the optimum crew size and interruption strategy for each activity in the project. Maxwell et al (1998) presents a stochastic simulation program to measure

the elapsed time and activity cost of each candidate crew for excavation projects. Their proposal uses an optimization rule to determine the best crew configuration from a range of possible configurations and determine the optimum resources required to complete a defined quantity of work in a timely and cost effective manner. Zhang and Li (2004) develop a model that integrates a simulation approach with an heuristic algorithm to optimize dynamic resource allocation for construction scheduling. The dynamic program minimizes the total execution time while considering the availability of resources and provides an alternative to optimize resource flow for scheduling in the construction field. Nassar (2005) present a spreadsheet based genetic algorithm (GA) model to optimally assign resources to repetitive activities of construction projects in residential and high rise projects. Lu et al (2008) develop a simplified simulation based scheduling approach to solve the problem of skilled laborer scheduling in a multi-site and multi-project context. Mohseli and Alshibani (2007) propose a methodology that combines GA and spatial technologies for optimization of crew formations for earth moving operations. A review of the aspects and modelling approaches in personnel allocation and scheduling can be found in Brucker et al (2011). As reported in this review, when people are involved, one must take into account not only different tasks and personnel constraints but also the different functions that workers may possess.

For this study, “skills” is defined as the ability of a worker to perform certain tasks well (De Bruecker et al, 2015). There are two different skill classes: the hierarchical class and the categorical class. In the case of hierarchical skills, workers with a lower skill level can do less than workers with a higher skill level. Workers with a higher skill level are more educated or have more experience and therefore can perform certain tasks better or faster. Models that have considered multi-functional workers have also been reported in the literature. Some researchers have only used two levels of skills: unskilled and skilled (Corominas et al, 2008; Lagodimus and Leopoulos, 2000) while other

researchers have used varying level of skills (Süer and Tummaluri, 2008; Srour et al, 2006). In the case of categorical skills, each specific task requires a specific skill or set of skills. There is no difference in skill level, so the skills of one worker are not higher or lower than the skills of another worker. Instead, the skills that a worker possesses determine which tasks he or she can perform. When a worker has the skills that allow him or her to perform several different tasks, the worker possesses each unique skill to perform each unique task. Some workers have one or more skills, and a worker who possesses different categorical skills is referred to as a multi-skilled worker (Gomar et al, 2002; Florez et al, 2013) or a cross-trained worker (de Matta and Peters, 2009; Li and Li, 2000).

When the workforce is multiskilled, workers perform several different tasks. Researchers have reported that when workers work in tasks that may differ from their core tasks there is usually a decrease in performance or efficiency and also that workers usually work more efficiently when working on their core task. Some researchers have considered an increase in the quality of the job (Batta et al, 2007; Tiwari et al, 2009), some have considered an increase in speed (Huang et al, 2011; Tiwari et al, 2009), and others have considered an increase in costs (Corominas et al, 2012; Brunner et al, 2011). Due to this varying levels of efficiency, a worker is said to be more suitable to work in certain tasks than in others. The suitability of a worker for a certain task is not related to the level of experience of that worker but rather to the worker's specialty that allows him to perform more efficiently in the core task than other.

For tasks requiring two or more workers to work together, compatibility is a measure that determines the relation a worker has with his co-workers and the way they work together (Nussbaum et al 1999; Kumar et al, 2013). Compatibility should be considered to make an appropriate worker assignment because teams of workers that work well together are critical to work success and effectiveness. Teams of workers that are

compatible may reduce potential noncooperation or conflict (Lin et al, 2012). A review of the state of the art in workforce planning incorporating skills can be found in De Bruecker et al (2015).

Nevertheless, despite this large body of work on the use of DSS for labor allocation and scheduling and certain applications for construction related decision making, the literature includes no reports on the use of a DSS for labor allocation for the masonry industry. To fill this void, this study aims to expand the set of decision-making tools available to masonry contractors and subcontractors for masons scheduling and allocation.

5.3 Mason functions

In the masonry industry, typically masons go through a formal or informal training to acquire the necessary technical knowledge to build all types of walls. In other words, with the apprenticeship program or on-the-job training, masons learn how to lay masonry units and are expected to be able to build any type of wall regardless of the difficulty of the wall or the craft of the wall. However, in reality masons become very specialized in the type of walls they can build and in the craft they can work with. Therefore, the superintendent at the site needs to consider the functions of each mason to optimally allocate the masons to the most suitable walls to increase quality and productivity.

For this study, we will consider that masons have three distinct features that impact work performance based on the responses of the interviewees detailed in Chapter 3. Firstly, masons have skills or the ability to perform certain tasks better than others. It will be considered that there are masons that are more skilled at working in long straight walls that do not have openings or windows and do not demand a high level of craft work. By contrast, other masons are more skilled to work on walls that demand a high level of detail such as openings, windows, and intricate work. Secondly, masons have

capabilities that allow them to work with one craft better than another. Although masons know how to lay bricks and how to lay blocks, it will be assumed there are brick masons and there are block masons. That is, two workers may have the same skill level, but their capabilities influence the tasks they are assigned to because they have a direct effect on quality and efficiency. Thirdly, masons have different personalities, and for walls requiring two or more masons, compatibility will be considered because this may influence the relation a mason will have with his co-workers and the way they work together (Nussbaum et al, 1999; Kumar et al, 2013).

5.4 Model framework

The DSS impacts the current decision process in masonry labor management by determining optimal crew configurations while considering crew labor needs, availability of masons, and wall requirements. The model determines the masons for each crew, the walls assigned to the crews, and the times to start the walls. As shown in Figure 41, the DSS is comprised of three modules: the data input module, the optimization module, and the reporting module.

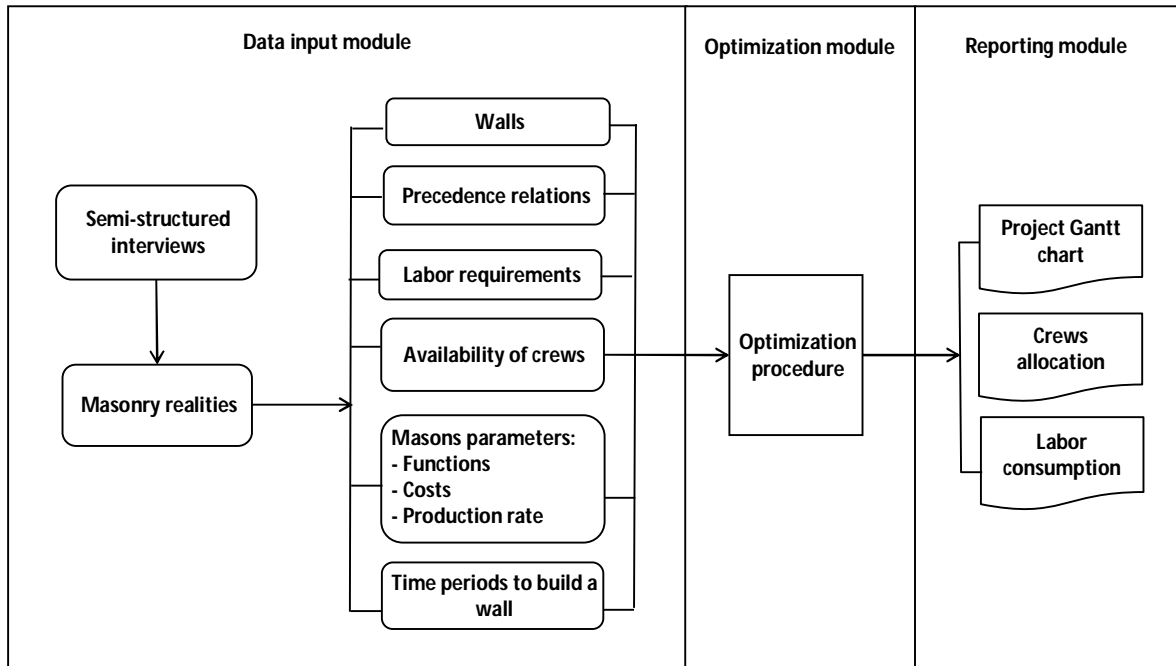

Figure 41 - Model framework

The data input module collects the information on the parameters required by the project. These parameters were determined based on the interviews with masonry stakeholders detailed in Chapter 3 and Chapter 4. The knowledge gathered in the interviews is used to incorporate masonry realities into the model and to better reflect what happens in a masonry site. From the responses, labor requirements, rules for crew design, and drivers for crew makeup were determined to be requirements in terms of the number of masons that can be working in one wall and the factors that affect crew performance and ultimately productivity. The data input module also includes, for every time period, information on the availability of crews, walls that are available for the masons to work in, and the precedence relations between the walls.

Once all the data input is entered, the optimization module builds the model that assigns crews to minimize the time to build walls in a masonry project. The allocation process consists of determining which crew is going to be working in which wall and at

which time. Each wall demands a number of masons and each crew is comprised of a certain number of masons, so the model determines which crew from the crews available is assigned to each wall. To build the schedule, the model uses binary decision variables to define the times each crew is working in a specific wall. The model determines the total number of crews and ultimately the total number of masons that are working along the planning horizon. Furthermore, the model determines the cost of allocating crews in each period of time. The model's objective is to allocate crews of masons so that the completion time is minimized. Finally, the reporting module of the optimization model is a detailed schedule of the times to start the walls, the number of masons, and the crew configuration under the optimal schedule.

5.5 Model formulation

The proposed model can help masonry superintendents and subcontractors design optimal crews, while considering crew labor needs, availability of workers, and wall requirements. The model determines which crew is assigned to which wall, the times that each crew and consequently each mason is working and the times to start the walls.

The formulation includes the set of walls I , the set of crews J , and the set of masons R . The set J_r contains the crews with mason r , while the set J_i contains the crews capable of building wall i . The formulation also includes a set of precedence relations between the walls, A . That is, if wall $i \in I$ precedes wall, $i' \in I$ then $(i, i') \in A$.

The model also includes parameter q_i representing the number of masons needed to construct wall i whereas parameter p_j represents the number of masons in crew j . Parameter v_{ij} represents the number of time periods required to complete wall i with crew j . Parameter c_j^{wage} represents the wage (per period of time) of crew j .

Parameter b_t represents the available budget for time t . The binary parameter a_{jt} takes the value of 1 if crew j is available in time t ; it takes the value of 0, otherwise.

The structural binary variable x_{ijt} takes the value of 1 if crew j is assigned to wall i at time t ; it takes the value of 0, otherwise. The binary variable y_{ijt} takes the value of 1 if wall i is assigned to crew j and scheduled to start at the beginning of time t ; it takes the value of 0, otherwise. In addition the (auxiliary) binary variable z_{ij} takes the value of 1 if wall i is assigned to crew j ; it takes the value of 0, otherwise. The binary variable r_{it} takes the value of 1 if wall i is scheduled to start at the beginning of time t ; it takes the value of 0, otherwise. Variable \bar{w}_t represents the number of masons working in the scheduled walls at time t (where $\bar{w}_0 \equiv 0$). The auxiliary variable \bar{c}_t^{labor} denotes the labor cost incurred at time t . The decision variable C_{\max} represents the completion time of the latest wall in the project.

The proposed mixed-integer program follows:

$$\min = C_{\max} \tag{1}$$

subject to,

$$C_{\max} \geq (t + v_{i,j} - 1) \cdot y_{i,j,t} \quad ; i \in I, j \in J, t = 1, \dots, T \tag{2}$$

$$\sum_{t=1}^T \sum_{j \in J_i} y_{i,j,t} = 1 \quad , i \in I \tag{3}$$

$$\sum_{i \in I} x_{i,j,t} \leq 1 \quad ; j \in J, t = 1, \dots, T \tag{4}$$

$$\sum_{j \in J_r} \sum_{i \in I} x_{i,j,t} \leq 1 \quad ; t=1, \dots, T, r \in R \quad (5)$$

$$z_{i,j} = \sum_{t=1}^T y_{i,j,t} \quad ; i \in I, j \in J \quad (6)$$

$$v_{i,j} \cdot z_{i,j} = \sum_{t=1}^T x_{i,j,t} \quad ; i \in I, j \in J \quad (7)$$

$$v_{i,j} \cdot y_{i,j,t} \leq \sum_{t=t}^{t+v_{ij}-1} x_{i,j,t} \quad ; i \in I, j \in J, t \in T \quad (8)$$

$$\sum_{i \in I} q_i \cdot x_{i,j,t} \leq a_{j,t} \cdot p_j \quad ; j \in J, t \in T \quad (9)$$

$$x_{i,j,t} \leq a_{j,t} \quad ; i \in I, j \in J, t \in T \quad (10)$$

$$y_{i,j,t} \leq a_{j,t} \quad ; i \in I, j \in J, t \in T \quad (11)$$

$$\bar{w}_t = \sum_{i \in I} \sum_{j \in J} x_{i,j,t} \cdot p_j \quad i \in I, t = 1, \dots, T \quad (12)$$

$$c_t^{-labor} = \sum_{j \in J} c_j^{wage} \cdot x_{i,j,t} \quad ; t = 1, \dots, T \quad (13)$$

$$c_t^{-labor} \leq b_t \quad ; t = 1, \dots, T \quad (14)$$

$$r_{i,t} = \sum_{j \in J_i} y_{i,j,t} \quad ; i \in I, t \in T \quad (15)$$

$$r_{i',t} \leq \sum_{j \in J} \sum_{t=1}^{t-v_{i',j}} y_{i',j,t} \quad ; (i, i') \in A, t \in T \quad (16)$$

$$x_{i,j,t} \in \{0,1\} \quad ; i \in I, j \in J, t \in T \quad (17)$$

$$y_{i,j,t} \in \{0,1\} \quad ; i \in I, j \in J, t \in T \quad (18)$$

$$z_{i,j} \in \{0,1\} \quad ; i \in I, j \in J \quad (19)$$

$$r_{i,t} \in \{0,1\} \quad ; i \in I, t \in T \quad (20)$$

$$\bar{w}_t \in Z_+^1 \quad , t = 1, \dots, T \quad (21)$$

$$C_{\max} \in Z_+^1 \quad (22)$$

$$c_t^{-labor}, b_t \geq 0 \quad , t = 1, \dots, T \quad (23)$$

As is shown in (1), the model seeks to minimize the total execution time when scheduling all the walls in a project. The group of constraints in (2) sets C_{\max} to the completion time of the latest wall in the schedule. The set of constraints in (3) guarantees that every wall is built. The set of constraints in (4) guarantees a crew builds at most one wall at any given time while the set of constraints in (5) guarantees that a mason is not working in two crews at any given time. The set of constraints in (6) activates the corresponding z variables when a given wall is assigned to a crew. The set of constraints in (7) and (8) guarantee that a crew that is assigned to a wall stays in the same wall until the wall is finished. Note that a crew works during consecutive time periods for the whole duration of the wall, that is, no interruptions are allowed. The group of constraints in (9) guarantees that at any time, the available workforce is able to fulfill the demand of labor. The bound constraints in (10) and (11) guarantee that a crew assigned to a wall is a crew that is available. The expression in (12) denotes the number of masons working in time t . The expression in (13) denotes the labor cost in time t . The group of constraints in (14) guarantees that the labor cost does not exceed the available budget at any given time. The set of constraints in (15) articulates decision variables y with auxiliary variables r . The precedence conditions between walls are accounted for in (16). Variable-type constraints (17), (18), (19), and (20) define variables x , y , z , and r as binary. Constraints (21) and (22) define variables \bar{w} and C_{\max} as non-negative integers. Finally, constraint (23) accounts for the non-negativity of $\bar{c}_t^{\text{-labor}}$ and b_t .

5.6 Numerical example

To illustrate how the contractor will determine the number of time periods that a crew j takes to build a masonry wall i , that is parameter v_{ij} , let us consider two walls. Assume the craft of each wall is either 8 inch concrete block (CMU) or regular brick. The

length and height of each wall in linear feet are known from the drawings of the project. Based on the number of openings (e.g. windows, door frames) and the amount of detailed work that is required to build each wall (e.g. cuts, arches), the difficulty for each wall is determined. In other words, each wall has been labeled by the superintendent as either an easy/normal wall or a difficult wall.

Figure 42 shows the information for wall 1. Note that wall 1 is an easy block wall. Given the length and height of the wall in linear feet and considering the nominal dimensions of an 8 inch block (8"x8"x16"), it can be determined the wall is 14 units long and has 12 courses (12 units high). Based on the length of the wall and assuming that one mason is assigned every 15 linear feet of wall, two masons will be working on this wall, that is, the wall will be built using a two-mason size crew.

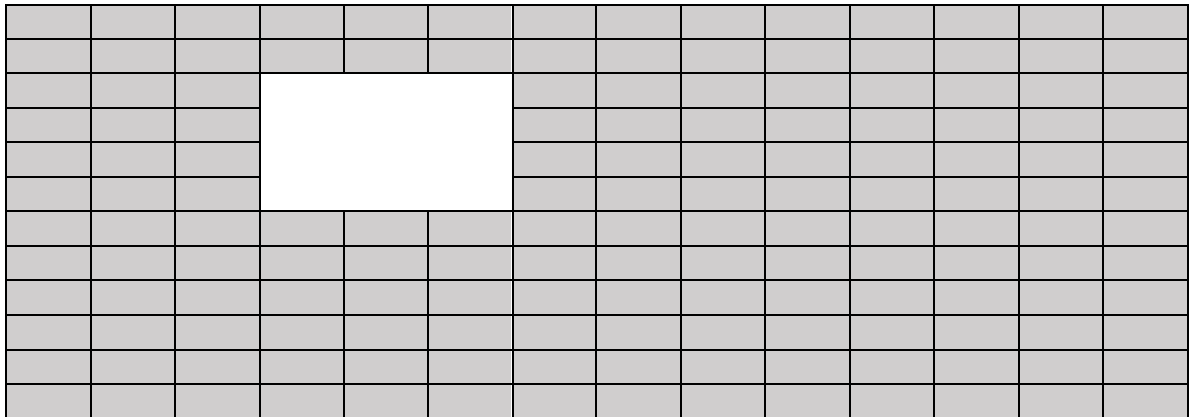

Wall 1

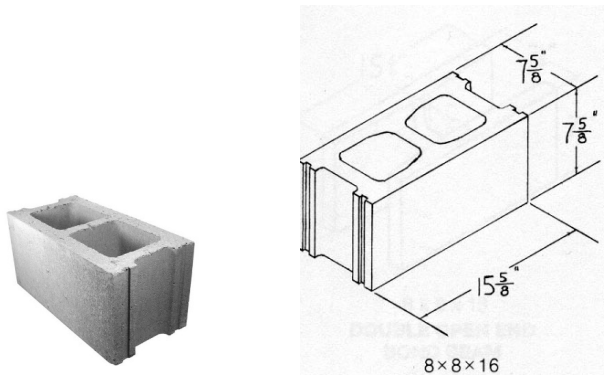
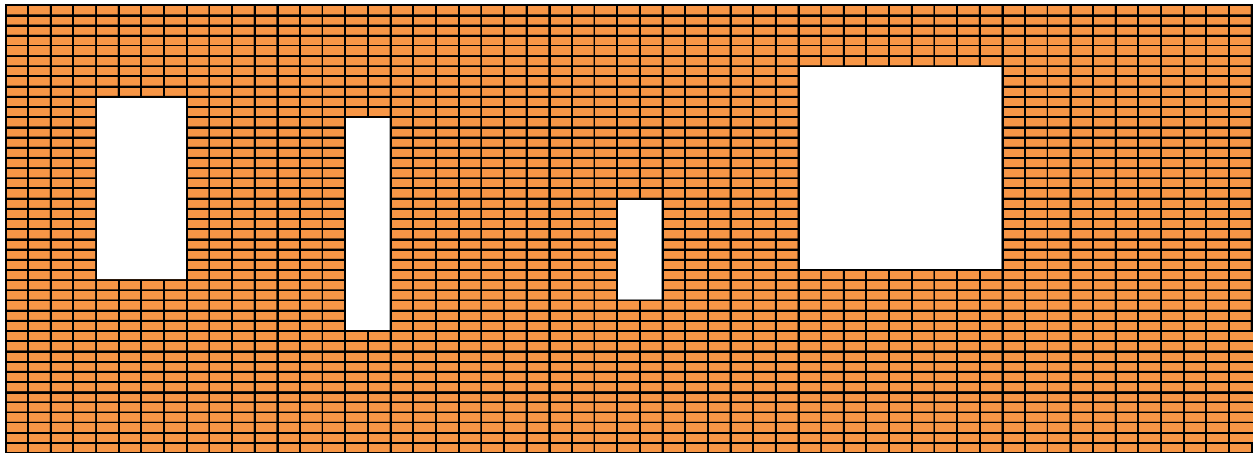

Figure 42- Information for wall 1

Wall 1		
Craft	block	
Difficulty	easy	
# masons	2	
Length	18 ft.	14 units
Height	8 ft.	12 units
Total	168 units	

Figure 43 shows the information for wall 2. Note that wall 2 is a difficult brick wall. Given the length and height of the wall in linear feet and considering the nominal dimensions of a regular brick (2"x 4" x 8"), it can be determined that the wall is 52 units long and has 35 courses (35 units high). Based on the length of the wall and considering that one mason is assigned every 15 linear feet of wall, a three-mason size crew will be working on this wall.



Wall 2

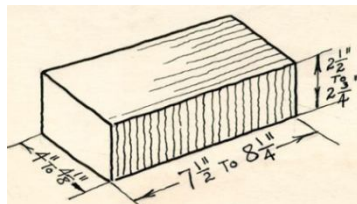

Figure 43- Information for wall 2

Wall 2		
Craft	brick	
Difficulty	difficult	
# masons	3	
Length	35 ft.	52 units
Height	8 ft.	44 units
Total	2288 units	

Based on the proposed drivers for designing crews described in Chapter 4, it is assumed the productivity of a crew is affected by: how suitable the crew is to work in a specific type of wall, how well the crew works with a type of material, and how the masons in the crew get along and work well together. In other words, the productivity is

affected by three factors: the suitability, the craft, and the compatibility of the crew. Consequently, it is assumed there is a productivity factor that results from combining the suitability, craft, and compatibility scores and that ultimately affects the productivity of the crew.

The suitability score quantifies how well a mason works in an easy/normal or difficult wall (see Table 3). When a crew j is formed, it is assumed the suitability of the crew is the minimum score on suitability for the masons that are in the crew. For instance, for a three-mason crew formed with mason 1, mason 3, and mason 4, the suitability to work in an easy wall is:

$$suit_j = \min\{0.8, 0.6, 0.9\} = 0.6$$

Table 3- Suitability score for masons

Suitability		
	Easy	Difficult
Mason 1	0.8	0.3
Mason 2	0.3	0.7
Mason 3	0.6	0.8
Mason 4	0.9	0.4
Mason 5	0.6	0.9

Note that the higher the suitability score, the more suitable a mason is to work in a specific type of wall. Consequently, the higher the suitability score the more suitable a crew is to work in a specific type of wall.

The craft score quantifies how well a mason works with a material, that is, how well a mason lays brick or lays block (see Table 4). Similarly, the craft score for a crew j is assumed to be the minimum craft score among the masons that are in the crew. For

instance, for a crew formed with mason 1, mason 3, and mason 4, the craft score to work in a block wall is:

$$craf_j = \min\{0.6,0.9,0.7\} = 0.6$$

Table 4- Craft score for masons

	Craft	
	Block	Brick
Mason 1	0.8	0.6
Mason 2	0.5	0.7
Mason 3	0.8	0.9
Mason 4	0.9	0.7
Mason 5	0.8	0.6

Note that the higher the craft score, the more capable a mason is to work with a specific craft. Consequently, the higher the craft score the more capable a crew is to work with a specific craft.

The compatibility score quantifies how masons work well together (see Table 5). When a crew j is formed, the compatibility score of the crew is the minimum of the compatibility score between the masons that are in the crew. For instance, for a crew formed with mason 1, mason 3, and mason 4, the compatibility score when working in a wall is:

$$comp_j = \min\{0.4,0.8,0.7\} = 0.4$$

Table 5- Compatibility score for masons

Compatibility					
	Mason 1	Mason 2	Mason 3	Mason 4	Mason 5
Mason 1	-	0.9	0.4	0.8	0.9
Mason 2	0.9	-	0.5	0.6	0.7
Mason 3	0.4	0.5	-	0.7	0.8
Mason 4	0.8	0.6	0.7	-	0.9
Mason 5	0.9	0.7	0.8	0.9	-

Note that the higher the compatibility score, the better the masons get along. Consequently, the higher the compatibility score, the better masons work well together. Therefore, the productivity score for a crew j is given by equation (1):

$$prod_j = \frac{craft_j + suit_j + comp_j}{3}$$

Let's calculate the productivity score for the crew that is assigned to wall 1. Table 6 shows the characteristics of wall 1. Assume wall 1 will be built with a crew composed of mason 1 and mason 3. To calculate the suitability, craft, and compatibility scores for wall 1:

Table 6 - Characteristics of wall 1

Wall 1		
Craft	block	
Difficulty	easy	
# masons	2	
Length	18 ft.	14 units
Height	8 ft.	12 units
Total		168 units

The suitability score is given by (see Table 3):

$$suit_j = \min\{0.8, 0.6\} = 0.6$$

The craft score is given by (see Table 4):

$$craft_j = \min\{0.8, 0.8\} = 0.8$$

The compatibility score is given by (see Table 5):

$$comp_j = \min\{0.9\} = 0.9$$

Therefore, the productivity score is given by:

$$prod_j = \frac{suit_j + craft_j + comp_j}{3} = \frac{0.6 + 0.8 + 0.9}{3} = 0.76$$

Now let's calculate the productivity F_j for a crew j :

$$F_j = prod_j \times n_j \times a$$

Where,

$prod_j$: productivity score for crew j

n : number of masons in crew j

a : average productivity per day per mason for craft m

Note that the average productivity per day per mason varies if it is for CMU block or for brick. The productivity for block is assumed to be 100 units per day per mason while the productivity for brick is assumed to be 500 units per day per mason.

Hence, the productivity for the crew (number of units per day per crew) composed of mason 1 and mason 3 is:

$$F_j = prod_j \times n_j \times a = 0.76 \times 2 \times 100 = 152$$

Now let's calculate the time that it will take crew j to build wall 1:

$$v_{ij} = \frac{U_i}{F_j}$$

Where,

v_{ij} : time it takes crew j to build wall i

U : total number of units in wall i

F_j : productivity of crew j

The time periods (days) that it will take the crew composed of mason1 and mason 3 to build wall 1 is:

$$v_{ij} = \frac{U_i}{F_j} = \frac{168}{152} = 1.10$$

In other words, it will take mason 1 and mason 3, 2 days to build wall 1.

Let's calculate the productivity score for the crew that is assigned to wall 2. Table 7 shows the characteristics of wall 2. Assume wall 2 will be built with a crew composed of mason 2, mason 3 and mason 5. To calculate the suitability, craft, and compatibility scores for wall 2:

Table 7 – Characteristics of wall 2

Wall 2		
Craft	brick	
Difficulty	difficult	
# masons	3	
Length	35 ft.	52 units
Height	8 ft.	44 units
Total	2288 units	

The suitability score is given by:

$$suit_j = \min\{0.7, 0.8, 0.9\} = 0.7$$

The craft score is given by:

$$craft_j = \min\{0.7, 0.9, 0.6\} = 0.6$$

The compatibility score is given by:

$$comp_j = \min\{0.5, 0.7, 0.8\} = 0.5$$

Therefore, the productivity score is given by:

$$prod_j = \frac{suit_j + craft_j + comp_j}{3} = \frac{0.7 + 0.6 + 0.5}{3} = 0.60$$

Now let's calculate the productivity F_j for a crew j :

$$F_j = prod_j \times n_j \times a$$

So the productivity for the crew composed of mason2, mason 3, and mason 5 is:

$$F_j = prod_j \times n_j \times a = 0.60 \times 3 \times 500 = 900$$

Now let's calculate the time that it will take crew j to build wall 2:

$$T = \frac{U}{F}$$

Where,

U : total number of units in wall

F_j : productivity of crew j

So the time periods (in days) that it will take the crew composed of mason2, mason 3 and mason 5 to build wall 2 is:

$$T = \frac{U}{F} = \frac{2288}{900} = 2.54$$

In other words, mason 2, mason 3, and mason 5 will take 3 days to build wall 2.

5.7 Comments on the productivity score

Note that this study is proposing a productivity function in terms of the compatibility, suitability, and craft scores of the masons in a crew. This function (shown below) was proposed for a number of reasons:

$$prod_j = \frac{suit_j + craft_j + comp_j}{3}$$

Reason 1: the function is a linear approximation since it is expected that the suitability, compatibility, and craft scores will affect the productivity. It is not the product of the scores because it is not expected that these may have such a significant reduction in the productivity. If it had been the product of the factors, even for a slight reduction of the

scores the total productivity score will be considerably reduced which does not truly reflect the capabilities of the masons. The masons are qualified to place units in a wall because they are trained to be masons. For example, let's suppose that a crew of two masons has the following scores:

- $suit_j = \min\{0.9, 0.9\} = 0.9$
- $craft_j = \min\{0.9, 0.9\} = 0.9$
- $comp_j = \min\{0.9\} = 0.9$

If the function were a product of the scores, the productivity score will be given by:

$$prod_j = suit_j \cdot craft_j \cdot comp_j = 0.9^3 = 0.729$$

Note that although the score of the masons is 90% in the three factors, the productivity score of the crew will be reduced to 72.9%. This new score on productivity does not reflect the high score of the suitability, compatibility, and craft of the masons in the crew.

Now let's assume that the suitability score of the same crew was reduced by 50%. That is, the suitability score will be 0.45. If the function were a product of the scores, a reduction of 50% in suitability will be:

$$prod_j = suit_j \cdot craft_j \cdot comp_j = 0.9 \cdot 0.9 \cdot 0.45 = 0.3645$$

Note that although the reduction of the suitability was 50%, the productivity score of the crew will be reduced to 36.45%.

Reason 2: the function has a number three that divides the sum because it is assumed that the three factors influence the productivity score equally. Therefore, the productivity score will be the mean value of the scores. Furthermore, since the range of the three scores is between 0 and 1, the resulting productivity score will also be in this range and any influence to the actual productivity of the masons will be a percentage of the productivity.

Reason 3: the coefficients of the three scores (compatibility, suitability, and craft) in the function are assumed to be equal. In this particular case, $a = 1/3$, $b = 1/3$, $c = 1/3$. For this study there is no more data in hand so this assumption applies. However, further studies can be developed to determine the coefficient for each one of the factors using a mathematical regression.

In summary, further studies are needed to collect more data on the compatibility, suitability, and craft scores of various crews, working on different crafts and in multiple sites. This new data will help refine the coefficients and the productivity function. It is expected that a refined function will estimate more precisely the productivity of a masonry crew.

5.8 Case study: scheduling a masonry project

This case study is based on a real 14 story apartment building with an area of 20,000 ft² in Ann Arbor, Michigan. The floor division of the building is as follows: there is a basement with an underground parking garage; the first floor houses a multi-flex space with: private and open study areas, lobby, a community lounge and an athletic club. The second floor through the fourteenth floor has units with a variety of floor plans including

one bedroom, two bedrooms, three bedrooms, and four bedrooms. The floor height is about 9 feet and 2 inches. The façade of the building has color brick (4"x4"x12") and there are interior columns and walls that are made up of color brick in the first and second floors. Figure 44a shows the east façade and Figure 44b shows the characteristics of the brick.

For a week during the fall 2015, the allocation and schedule of the masons as well as the labor productivity were documented on site. The purpose of the case study was to compare the week's results against the model's allocation and schedule and determine whether there is a change in the completion time and the working patterns. Previous to starting the data collection process, the superintendent and the contractor had determined which walls the masons were going to work during that week. Additionally, the superintendent had determined the order to build the walls, that is, the precedence relations between the walls. The masons started on the east side of the building, continued on the south, then north, and finally on the west side. For the case study it was considered that each wall is a segment that extends from one corner to another corner. The masons worked in walls that ranged from 20 ft. to 60 ft. in length during that week.

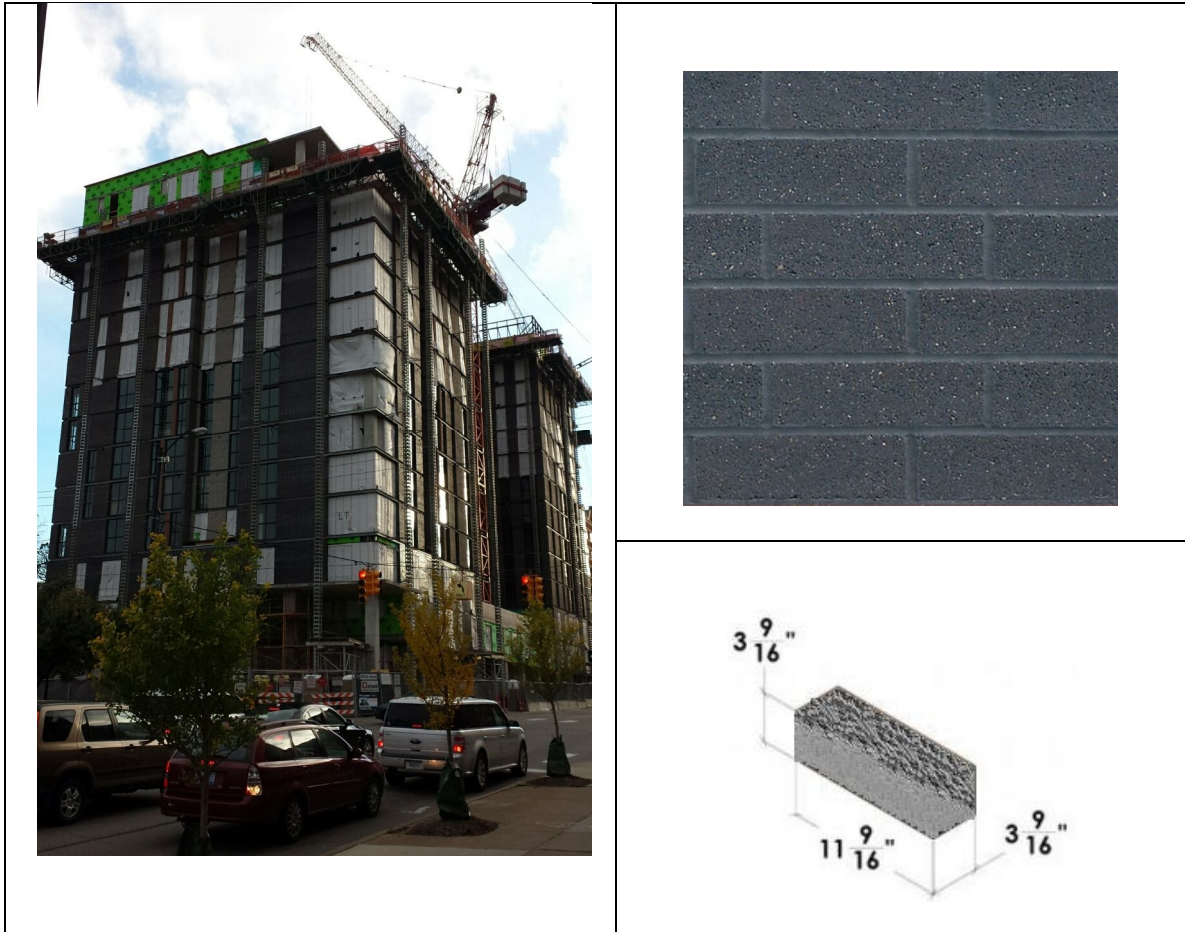

Figure 44- East façade of the building; Characteristics of the walls and the brick

Based on the workload, the superintendent determined that six masons were needed to complete the walls. That is, six masons were available to build the walls. The supply had no variations in the number of masons so there were six masons available during the entire week and 64 possible crew formations (see below):

$$crews = \binom{6}{0} + \binom{6}{1} + \binom{6}{2} + \binom{6}{3} + \binom{6}{4} + \binom{6}{5} + \binom{6}{6} = 1 + 6 + 15 + 20 + 15 + 6 + 1 = 64$$

During the week, the walls were built with crews of one, two, and three masons, so there were only 41 possible crew formations (see Table 8). Note that the binary parameter takes the value of 1 if a mason belongs to that crew; it takes the value of 0, otherwise.

Table 8- Masons that belong to each possible crew formation

Crew	Mason 1	Mason 2	Mason 3	Mason 4	Mason 5	Mason 6
Crew 1	1	0	0	0	0	0
Crew 2	0	1	0	0	0	0
Crew 3	0	0	1	0	0	0
Crew 4	0	0	0	1	0	0
Crew 5	0	0	0	0	1	0
Crew 6	0	0	0	0	0	1
Crew 7	1	1	0	0	0	0
Crew 8	1	0	1	0	0	0
Crew 9	1	0	0	1	0	0
Crew 10	1	0	0	0	1	0
Crew 11	1	0	0	0	0	1
Crew 12	0	1	1	0	0	0
Crew 13	0	1	0	1	0	0
Crew 14	0	1	0	0	1	0
Crew 15	0	1	0	0	0	1
Crew 16	0	0	1	1	0	0
Crew 17	0	0	1	0	1	0
Crew 18	0	0	1	0	0	1
Crew 19	0	0	0	1	1	0
Crew 20	0	0	0	1	0	1
Crew 21	0	0	0	0	1	1
Crew 22	1	1	1	0	0	0
Crew 23	1	1	0	1	0	0
Crew 24	1	1	0	0	1	0
Crew 25	1	1	0	0	0	1
Crew 26	1	0	1	1	0	0
Crew 27	1	0	1	0	1	0
Crew 28	1	0	1	0	0	1
Crew 29	1	0	0	1	1	0
Crew 30	1	0	0	1	0	1
Crew 31	1	0	0	0	1	1
Crew 32	0	1	1	1	0	0
Crew 33	0	1	1	0	1	0
Crew 34	0	1	1	0	0	1
Crew 35	0	1	0	1	1	0
Crew 36	0	1	0	1	0	1
Crew 37	0	1	0	0	1	1
Crew 38	0	0	1	1	1	0
Crew 39	0	0	1	1	0	1
Crew 40	0	0	1	0	1	1
Crew 41	0	0	0	1	1	1

The crews built nine walls. The nine walls were located on the east, south, north, and west elevations of the building. Figure 45 shows the north façade of the building. The precedence relations between the walls are detailed in Figure 46. Note that wall 4 can only be built if wall 1, wall 2, and wall 3 are finished. In a similar manner wall 7 can only be built if wall 4, wall 5, and wall 6 are finished. This implies that wall 1, wall 2 and wall 3 are also finished by the time wall 7 is started.



Figure 45- North façade of the building

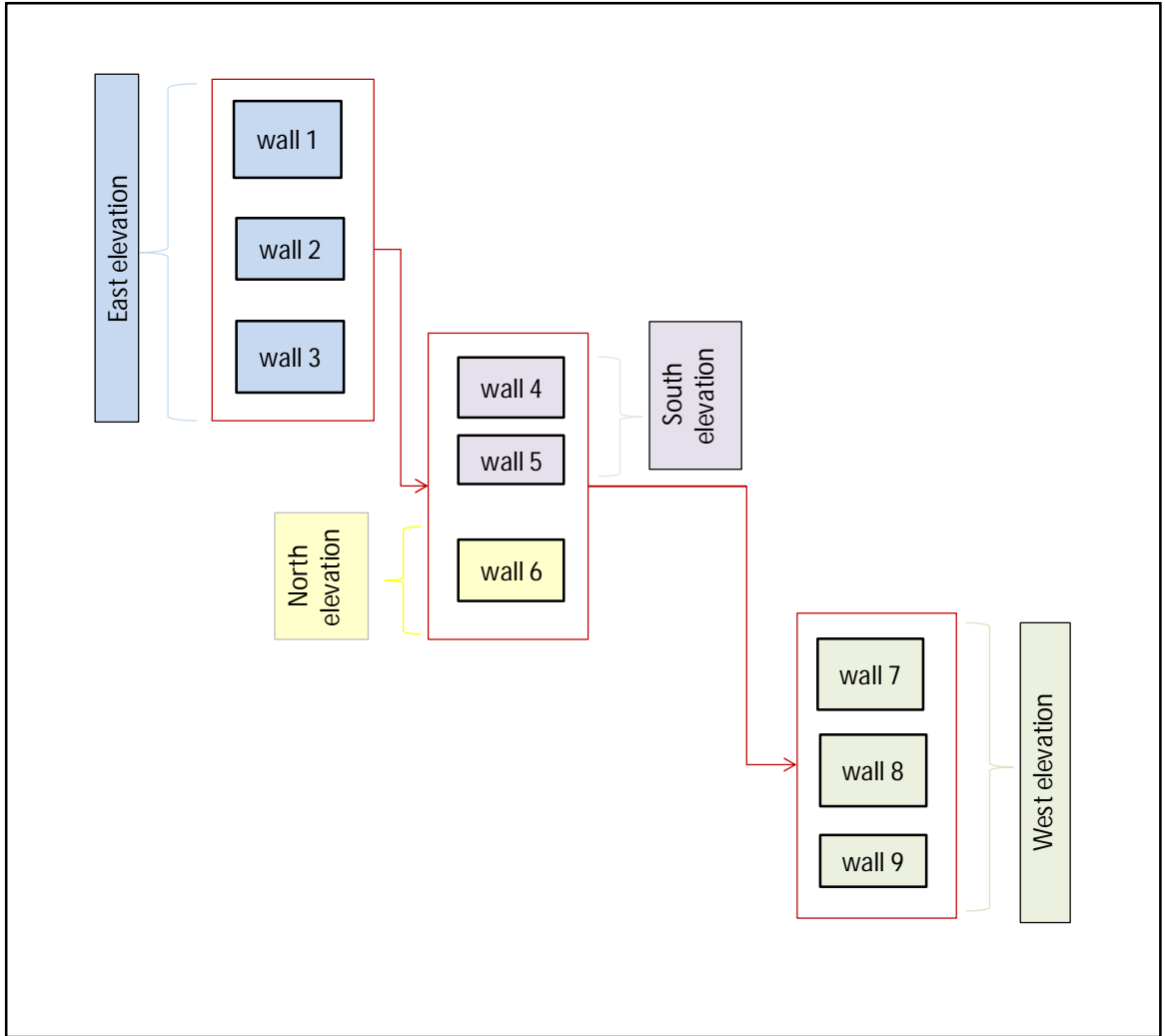

Figure 46- Precedence relations between the walls

The nine walls have the characteristics detailed below (Table 9):

Table 9- Characteristics of the nine walls

	Wall 1	Wall 2	Wall 3
Walls			
Craft	Brick	Brick	Brick
Difficulty	Difficult	Easy/normal	Difficult
# masons	2	2	2
Length (units)	35	30	27
Height (units)	27	27	27
Total units	945	810	729







	Wall 4	Wall 5	Wall 6
Walls			
Craft	Brick	Brick	Brick
Difficulty	Difficult	Easy/normal	Difficult
# masons	1	2	3
Length (units)	33	35	46
Height (units)	27	27	27
Total units	891	945	1242

Table 9- (continued)

	Wall 7	Wall 8	Wall 9
Walls			
Craft	Brick	Brick	Brick
Difficulty	Difficult	Easy/medium	Difficult
# masons	2	2	2
Length (units)	37	60	30
Height (units)	27	27	27
Total units	999	1620	810

Note that the number of masons in each wall was the actual manpower on site utilized to build each wall. This number in some cases is different from the rule of the number of masons per wall (see Section 4.2.1 Rule 9), but for the purpose of the comparison the model and the case study were studied with the actual number of masons used on site. After the information on site was compiled, the superintendent then provided information on the suitability, the craft, and the compatibility scores for the six masons. In other words, the superintendent was asked to provide scores for each of the masons based on the knowledge he had about the masons and their characteristics. Table 10 shows the compatibility scores.

Table 10- Compatibility score for masons (superintendent provided scores)

Compatibility						
	Mason 1	Mason 2	Mason 3	Mason 4	Mason 5	Mason 6
Mason 1	-	0.5	0.9	0.5	0.9	0.5
Mason 2	0.5	-	0.5	0.5	0.5	0.9
Mason 3	0.9	0.5	-	0.1	0.9	0.1
Mason 4	0.5	0.5	0.1	-	0.9	0.5
Mason 5	0.9	0.5	0.9	0.9	-	0.5
Mason 6	0.5	0.9	0.1	0.5	0.5	-

For simplicity, the superintendent was asked to state how well the masons get along: not very well, well, excellent. Based on the responses of the superintendent, a compatibility score between masons was determined (0.1=not very well, 0.5=well, 0.9=excellent). Note that the scores were taken similarly to a Likert-scale, that is, the responses were scaled so that the distance on each item is equal.

For the suitability score, the masons were scored by the superintendent on a scale from 0 to 1 based on previous work and productivity rates working on easy/normal walls and difficult walls. In addition, the superintendent considered their performance on the site from previous to the data collection. Table 11 shows the scores provided by the superintendent for the six masons that were available on the site. Note that the suitability is directly related to the specialty of the mason and in most cases a mason that is good working in difficult walls is not good working in an easy wall and vice versa.

Table 11- Suitability score for masons

Suitability		
	Easy	Difficult
Mason 1	0.8	0.5
Mason 2	0.6	0.7
Mason 3	0.4	0.8
Mason 4	0.9	0.5
Mason 5	0.6	0.9
Mason 6	0.9	0.7

Similarly, the superintendent provided a craft score for the masons on a scale from 0 to 1 based on previous work and experience working with brick and block walls. Table 12 shows the scores provided by the superintendent for the six masons that were available on the site.

Table 12- Craft score for masons

Craft		
	Block	Brick
Mason 1	0.8	0.7
Mason 2	0.6	0.8
Mason 3	0.8	0.9
Mason 4	0.9	0.7
Mason 5	0.8	0.6
Mason 6	0.9	0.6

The weight of the three factors (compatibility, suitability, and craft) is assumed to be equal, that is, each one equally affects the productivity of the crew. With these scores and considering the characteristics of each mason, the time that each crew will take to build a wall is known in advance (please see section 5.6 for a detailed example on how to calculate the time). These times were used as input parameters to run the model and determine the schedule and allocation of masons. Note that time periods are measured in hours.

The results of the allocation and schedule of the masons (case study) are shown in several figures below. Figure 47 illustrates the working pattern for each mason. For instance, mason 2 works in wall 1 from time period 1 until time period 11. In time period 11, he/she shifts to wall 4 and works until time period 28. Once wall 4 is finished, he/she starts working in wall 7 in time period 29 until time period 37. Note that the report shows when a mason is working in a wall (productive time) and when the mason is not productive.

mason	Time period																																								
	1	2	3	4	5	6	7	8	9	10	11	12	13	14	15	16	17	18	19	20	21	22	23	24	25	26	27	28	29	30	31	32	33	34	35	36	37	38	39	40	41
1	wall 1											wall 6											wall 7																		
2	wall 1											wall 4											wall 7																		
3	wall 3										wall 5											wall 8																			
4	wall 3										wall 5											wall 8																			
5	wall 2										wall 6											wall 9																			
6	wall 2										wall 6											wall 9																			

Figure 47- Report per mason (case study)

Figure 48 illustrates the working pattern for each crew (case study). For instance, crew 21 (mason 5 and mason 6) works in wall 2 from time period 1 until time period 10. In time period 29, the crew is re-grouped and starts working in wall 9 in time period 29 until time period 37. Note that mason 5 and mason 6 work in crew 21, which is a two-mason crew. Also note that mason 5 and mason 6 work together with mason 1 in crew 31, which is a three-mason crew.

crew	Time period																																								
	1	2	3	4	5	6	7	8	9	10	11	12	13	14	15	16	17	18	19	20	21	22	23	24	25	26	27	28	29	30	31	32	33	34	35	36	37	38	39	40	41
2	wall 1											wall 4											wall 7																		
7	wall 3										wall 5											wall 8																			
16	wall 3										wall 5											wall 8																			
21	wall 2										wall 6											wall 9																			
31	wall 6											wall 9											wall 9																		

Figure 48- Report per crew (case study)

Figure 49 shows the optimal timing of the walls (case study). For instance, wall 1 starts in time period 1 and finishes in time period 11, while wall 4 starts in time period 12 and finishes in time period 28. Note that wall 1, wall 2, and wall 3 were completed before any other wall could start. In a similar manner, wall 4, wall 5, and wall 6 were completed before the next three walls (wall 7, wall 8, and wall 9) started. Note that the completion time of the latest wall in the schedule (wall 8) is time period 41. Thus, starting in time period 1 (wall 1, wall 2, wall 3) all the walls were completed by time period 41. As shown in Figure 49, the schedule only allows *go-no-go* decisions, that is, walls were not partially built and once they are in progress are not interrupted.

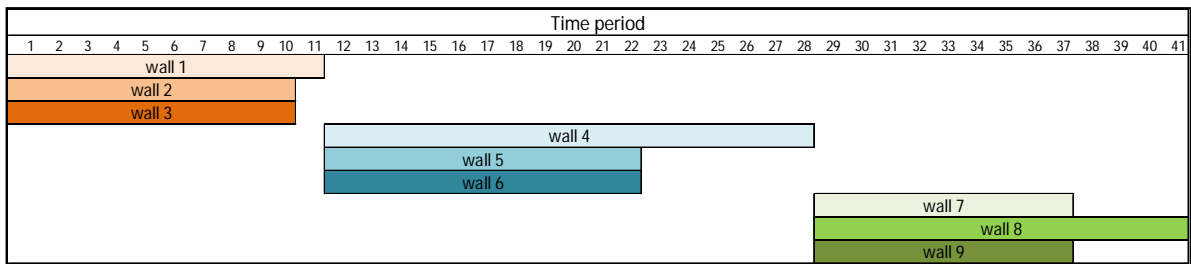

Figure 49- Schedule for the walls (case study)

Figure 50 shows the optimal timing of the walls (model). Note that the completion time of the model is the same completion time as that of the case study. However, let's look at the results more closely. Note that the completion time in the model of the first group of walls (wall 1, wall 2, and wall 3) is time period 10, whereas the completion time in the case study for the first group in the is time period 11. Also note that the completion time of the second group of walls (wall 4, wall 5, and wall 6) is time period 26 whereas the completion time of the second group for the case study is time period 28. In other words, the model suggests that by using a different configuration of crews, 3 periods of time can

be saved in the first two groups of walls. In the third group of walls (wall 7, wall, 8 wall 9) the completion time of the model and the case study is time period 41.

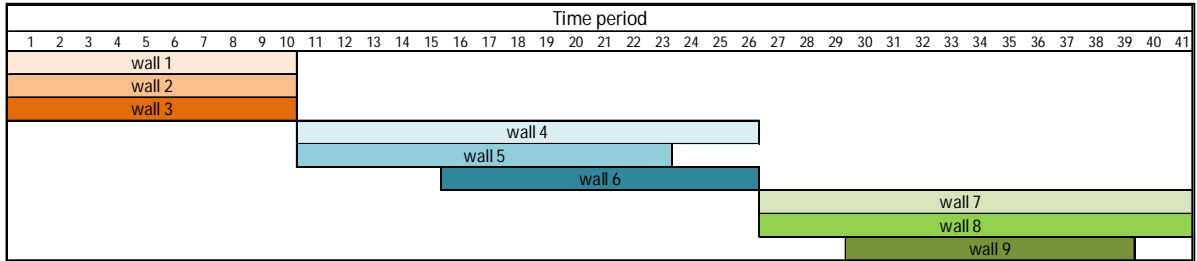

Figure 50- Schedule for the walls (model)

The results of the allocation and schedule of the masons (model) are shown in several figures below. Figure 51 illustrates the working pattern for each mason (model). For instance, mason 3 works in wall 3 from time period 1 until time period 10. In time period 11, he/she shifts to wall 4 and works until time period 26. Once wall 4 is finished, he/she starts working in wall 7 in time period 27 until time period 41. Note that the report shows when a mason is working in a wall (productive time) and when the mason is not productive.

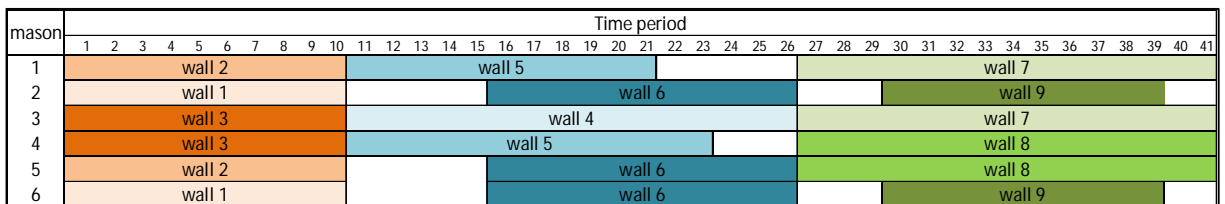

Figure 51- Report per mason (model)

Figure 52 illustrates the working pattern for each crew (model). For instance, crew 15 (mason 2 and mason 6) works in wall 1 from time period 1 until time period 10. In time period 30, the crew is re-grouped and starts working in wall 9 until time period 39. Note

that mason 5 and mason 6 work in crew 15, which is a two-mason crew. Also note that mason 5 and mason 6 work together with mason 2 in crew 37, which is a three-mason crew.

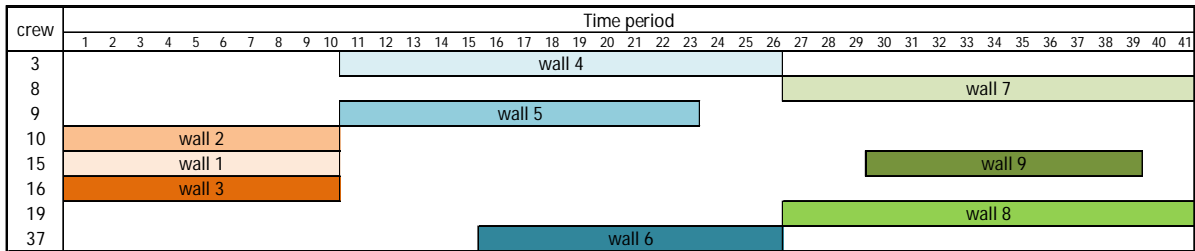

Figure 52- Report per crew (model)

Although the results show that the schedule of masons in the case study was the same in terms of time as that of the model, there are some aspects that can be observed by looking in more detail at the results.

First, the allocation of the model suggests that some masons are underutilized. For instance the model shows that between time period 11 and time period 15 crew 37 (mason 2, mason 5 and mason 6) is not assigned to a wall. Therefore, these masons can be allocated to another wall or can be assigned to a different task such as placing waterproofing, flashing and drip edge components, wall ties, and termination bars.

Second, the report per mason shows that the masons in the model are working concurrently during more time periods than in the case study. Note that in the case study mason 1, mason 3, mason 4, mason 5, and mason 6 are not working between time period 23 and time period 28 while in the model these masons are not working at non-concurrent times. Note that mason 1 is not working between time period 22 and time period 26, mason 2 is not working between time period 11 and time period 15 and then between time period 27 and time period 29, mason 4 between time period 24 and time

period 26, mason 5 is not working between time period 11 and time period 15, and mason 6 is not working between time period 11 and time period 15 and then between time period 27 and time period 29. The allocation of the model may facilitate the job of the superintendent since in different time periods he may need to find an alternative task for one or two masons instead of finding an alternative task for 4 masons at the same time.

Third, there are 33 non-working time periods in the model whereas in the case study there are 50 non-working time periods. This result shows that there are labor resources that are underutilized and the superintendent may assign the masons that are not working to perform non-productive work. Fourth, the average productivity score of the crews that are used in the model ($=0.60$) is higher than the average productivity score of the crews that are used in the case study ($=0.52$). Therefore, in the model the allocation is considering the characteristics of the masons and how do they relate to the job conditions to get which may result in a higher productivity.

The optimal timing of the walls is also solved for the case when there are 7 walls. Figure 53 shows the optimal timing of the walls (model). Note that the completion time of the model is time period 36. Under the same conditions (7 walls), the completion time of the walls in the case study is time period 37 (see Figure 54).

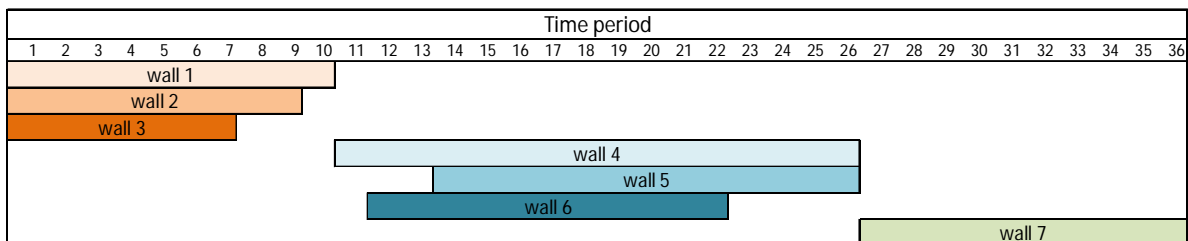

Figure 53- Schedule for the walls (model)

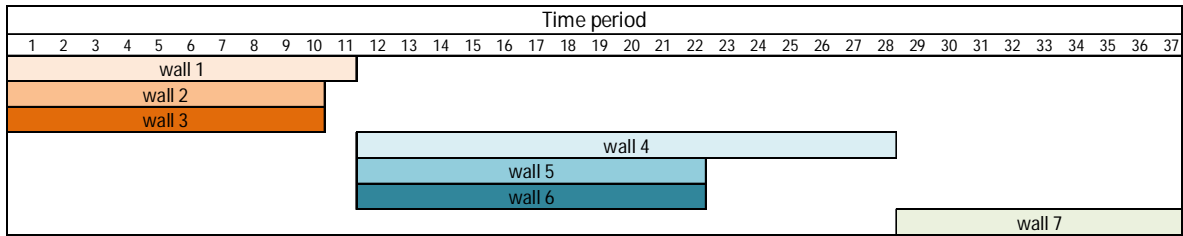

Figure 54- Schedule for the walls (case study)

This solution shows that the model can optimize the allocation of crews to reduce the completion time to build the walls. Note that wall 8 and wall 9 were omitted since wall 8 is a very long wall and the number of masons assigned to this wall on site was less than the number of masons suggested by the Rule 9 (Section 4.1.2). Wall 8 was built using a two-mason crew while the rule suggests using a three-mason crew. Since the number of masons directly affects the productivity of the crew, this result may be influencing the time it takes to build wall 8 which actually is increasing the total completion time of the model. This result further suggests a more thorough study to correctly predict the productivity function and its coefficients. In addition further studies can be completed to evaluate the allocation of masons in both brick and block jobs as well as jobs that have brick and block walls.

5.9 Discussion chapter 5

In this chapter, a literature search on labor scheduling and allocation models was conducted. The search aimed to describe the methods and approaches that have been developed to address the problem of labor scheduling and allocation in the construction field. After the search, the problem of allocating and scheduling labor in masonry was described, along with its assumptions and its context. Then, the framework of the DSS was explained. The model formulation was formally introduced to the labor allocation and scheduling literature. The study presents a mixed integer programming formulation

to the crew scheduling and allocation problem in masonry construction. The model solves the crew allocation problem by determining the optimal crew formation that minimizes time while considering labor requirements, availability of crews and precedence relations of the walls. A numerical example was presented to explain how the drivers for crew makeup can be calculated. In addition, data from real case study is used to compare the schedule and allocation used on site with the one proposed by the model. The comparison shows the model can optimize the allocation of crews to reduce the completion time to build the walls while not only maximizing the utilization of masons but also opportunities for concurrent work.

CHAPTER 6

GENERAL DISCUSSION

The crew allocation process in masonry construction is challenging. Masonry is labor-intensive and often the superintendent needs to schedule and allocate crews to avoid disruptions and maximize production. Multiple masons with different skills, capabilities, and personalities are present in the jobsite at any one time and the superintendent needs to consider the functions of the masons to balance between the complexity of the job, the quality of work and the need for high production rates.

The proposed DSS aims to help contractors and superintendents allocate crews of masons in masonry projects. The model integrates a qualitative approach and a modeling approach in an attempt to understand masonry site realities and develop a tool that can help alleviate some the challenges faced by masonry contractors and superintendents in their day-to-day practices. Typical contractors' requirements are included to address realistic scenarios experienced by masonry decision-makers in the jobsite. These requirements dictate the rules contractors use to design and makeup crews. In addition, the model includes social sustainability considerations that links workers to career goals and allows contractors to not only develop more qualified staff for its future projects, but also gives the masons opportunities for career growth and development. The inclusion of social sustainability helps increase job satisfaction and efficiency that arise from suitable worker assignment to crews and tasks. In other words, the DSS is a tool for sustainable labor management in masonry construction that takes into consideration information on workers and job characteristics with the intention of assisting decision makers to optimally allocate crews.

A mixed-integer programming (MIP) model was developed to enable the integration of workers needs and contractor requirements in the process of labor allocation. The model can be used to quantify strategies that maximize productivity, quality of work, and the well-being of workers. Developing such model is a necessary task. To plan and manage masonry construction, the model takes into account not only functions and characteristics of masons, but also rules for crew design and makeup, and project requirements in terms of personnel needs.

The model supports masonry contractors and superintendents in the challenging process of managing crews, that is, to determine the composition of each crew and the allocation of crews to maximize productivity and workflow while considering workers preferences and well-being. With the DSS, project managers and superintendents are not only able to identify working patterns for each of the masons, but also optimal crew formation, and labor costs. Data from several mason contractors is used to illustrate the decision model and showcase its capability. It is expected that the DSS will help contractors improve productivity and quality while efficiently managing masonry workers in a more and sustainable way.

The contributions for the masonry industry are two-fold. Firstly, the proposed model considers a set of rules that masonry practitioners typically use to design crews of masons and analytically captures the realities of masonry construction jobsites when managing labor. Secondly, it attempts to quantify and mathematically model the practices that contractors use for crew makeup and evaluate labor management allocation both in terms of contractor requirements and worker needs.

These new considerations should prove useful to masonry contractors and enable them to optimize the allocation of multiple workers in order to maximize workflow. An optimal schedule that considers the needs of workers and contractors contributes to formulate strategies to make project management more sustainable and increase the

benefits achieved by both workers and contractors. As further developments, the model may be modified to solve more complicated crew allocation problems by considering processes with other factors. Factors such as the impact of different working shifts or space availability can be considered in detail while developing the allocation system.

6.1 Benefits and limitations

Analysis of the interviews revealed several criteria for the makeup of crews. These criteria are used by masonry practitioners in designing crews and are used as guidelines when the foreman or superintendent is in the site trying to group masons in crews to form the most efficient crew. It was found there are three drivers for making up crews: compatibility, suitability and craft. 1) Compatibility of labor: masons have different personalities, ways to work, and get things done. Some masons work well together, but some masons just do not work well with certain other masons. They just do not get along and when they work with each other they seem to get less productive. This often creates a friction on the wall and can bring the whole crew down. The foreman tries to form crews with workers that are compatible because grouping masons that work well together can improve quality and increase throughput (Kumar et al, 2013). 2) Suitability: masons have different capabilities and can be more suitable to work in a specific type of wall. Some masons are very good levelling and plumbing and therefore are fast (and efficient) working on wall sections that require a high demand of craft work and technical work (e.g., openings, intricate corners, details, building leads, penetrations). Other masons are not good with the level and the plumb but are very fast (and efficient) working in the line and filling the wall. These masons can be assigned to non-craft work (e.g. straight walls or walls with little to no openings) because they are good at laying units to a line. The superintendent tries to assign a mason to a wall that matches the specialty of the mason to the type of work required in the wall. 3) Craft: most masons

learn (and know) how to lay brick and block but are usually faster at one craft than the other. Some masons are good at handling smaller units and are more detailed so they are better brick layers, whether some masons are stronger and are better at laying block. In other words, in masonry there are bricklayers and there are block masons. The superintendent tries to assign a mason to a wall section where the material match the craft the mason is faster at and thus more efficient at.

Therefore, to determine labor management practices that indeed maximize production and maximize workers satisfaction, the model realistically represents the realities in masonry construction sites and staffing practices.

One limitation is that the study considered equal weights for the drivers for crew makeup. Compatibility, suitability and craft were considered to equally influence the performance and therefore the productivity of the crew. Another limitation is that the study focused on labor management for CMU and brick. Other trades in masonry such as stone and tile among others may change the labor requirements observed in this study. This model does not consider other factors that were collected from the interviews and this work is an on going effort by the author.

6.2 Future research

Construction is a research area that is both technical and social, but most of the studies have focused on the technical aspect. An approach that integrates realities and includes social considerations such as personnel characteristics, the use of personal characteristics in crew formation, and strategies to maximize group performance can provide useful benefits to the construction industry. These considerations can help understand the context and identify and document personnel functions, but also provide numerous opportunities to address some of the industry's most relevant problems.

One opportunity is to develop theories about commitment and work relations. This provides relations with social fields such as sociology, organizational theory, social networks, and organizational behavior. By bringing social aspects to construction research, construction can bring findings and translate theories that have been developed for the social sciences. Such findings can help understand what aspects for instance influence crew formation and what should be the focus of managers when forming crews in construction and other group teams. For instance, a study that focuses on assessing workers characteristics for personnel selection, that is, research on the ability of skills or personalities to predict job and team performances. One focus can be determining if compatibility is more relevant than skills when forming groups or if skills play a more important role in group performance than personality. Such a study can bring considerable benefits to the construction industry and other industries and guide managers on what aspects to consider when designing work teams to maximize performance. Another focus is to evaluate if personality measures are valid predictors of job performance. A statistical model or predictive model can be developed to evaluate if indeed personality is correlated to job performance. Additionally, different personality constructs can be evaluated and tested in different job settings and with different occupations. The process flow shown in Figure 55 describes the process for developing theories for building teams. In contrast to quantitative research in which researchers only model aspects, a mixed-approach considers that empirical data and modeling remain in dialogue throughout the process.

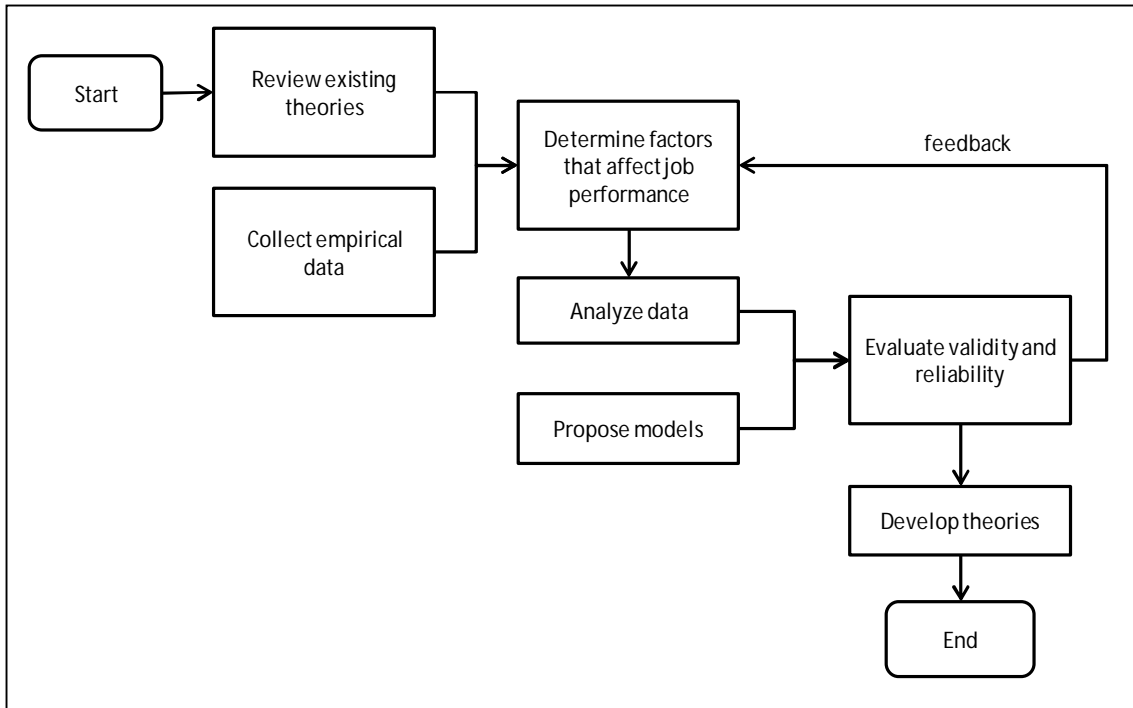

Figure 55- Team and job performance study approach

The process begins by reviewing the literature and existing theories that helps shape the initial research design. Then, empirical findings and emergent data are collected in the field and analyzed to generate initial explanations. However, the analysis of data collected in the field is not sufficient to develop theories and advance the understanding of the phenomenon under investigation. New knowledge is developed through an iterative process between data, theory and modeling. In other words, new theories are formed by extensively reading and analyzing empirical data together with a process of modeling and quantifying ideas derived from the literature and from the field.

This process of interrogating data against theories derived from the literature continues for as long as the resultant explanation and theories make sense and the description of the setting gives enough detail that the researcher can understand what is happening in the field. In order to continuously develop and refine theories from construction sites, different methods of data collection are used to help understand the complexity of a

natural setting. By using a combination of techniques, new data from one technique can further support or enrich existing data of the factors that affect team formation. Furthermore, the process of constant comparison between different factors that affect job performance allows identifying similarities and differences from the results of the model and from data derived from the field in support of theory development. Mixing methods leads to a greater understanding of the setting. Therefore, empirical data should be coupled with archival data to understand practices and how these are situated within a specific setting.

Another opportunity is to conduct an ethnographic research for interpreting crews. Ethnographic studies involve long-term and extensive participant observations that allow the researcher to fully observe the details of a site, listen to what is said, interpret interactions, and gather new insights to understand workplace realities. In ethnographic studies, the researcher engages extensively with project teams by observing the day-to-day practices of participants in their natural setting, that is, within their own frame of reference. Observations are performed over long periods of time (usually months) to minimize the disruption that the researcher may have on the population and allow the researcher to understand complex interactions occurring on site. By having a deep knowledge of a work setting, researchers are able to understand the meaning of words, actions, and artefacts used in a project environment, which may not always be explicit. Furthermore, this knowledge can be used to address practical and problem-based research and develop recommendations for construction site problems.

The use of research that includes realities may provide great opportunities for construction researchers to understand complex phenomena happening in jobsites. The interview-based research conducted in this study helped determine labor requirements and the day-to-day practices in masonry sites. By observing crews and interviewing masonry practitioners and stakeholders, this study helped understand how roles are

defined and the challenges of organizing crews for masonry work with the objective of informing crew management and planning strategies. This knowledge gathered through the use of empirical data enables construction practitioners to evaluate why some recent trends in organizing are congruent with the masonry workforce and why masonry contractors are likely to face challenges when planning workforce.

This study lays the groundwork for new models of masonry work, crew formation and organization that reflect changes in the division of labor and structure of a masonry construction site. It demonstrates how roles can be constructed, drawing on a set of interviews to propose an empirically grounded model of how masonry crews are formed and strategies to evaluate performance and productivity. The findings show why some trends in organizing crews are congruent with the characteristics of the workforce and why masonry contractors are likely to face challenges when planning and allocating workers in masonry work.

The strong link that emerges between industry and researchers is evident in construction research. Research that focuses on observing the natural context and how things are done in the site has the potential of helping researchers develop tools that are compatible with existing practices and practical to implement in actual construction sites. The interaction that results from bringing industry and researchers together can make both parties aware of what is happening in each while strengthening and providing greater collaboration. Finally, research about realities provides the means to understand complex issues rather than in parts using the traditional research methods in construction. For instance, this methodology can be used to understand information flow and integration throughout the delivery of construction infrastructure, adoption of new technology, performance effects of delivery methods, integration of team members, and social and technical factors that affect communication in construction sites.

The development of theoretical models by considering how natural settings and contexts are defined in construction jobsites contributes to identify practices and formulate strategies to make applied interventions in actual construction sites that are compatible with realities. Following this study, the idea is to expand the theoretical framework to other concepts such as crew coordination and information flow. By doing so, a wider scope of phenomena can be explained, including those beyond labor requirements.

REFERENCES

- Agapiou, A. (2002). Perceptions of gender roles and attitudes toward work among male and female operatives in the Scottish construction industry. *Construction Management and Economics*, 20(8), 697-705.
- Al-Bazi, A., & Dawood, N. (2010). Developing Crew Allocation System for the Precast Industry Using Genetic Algorithms. *Computer-Aided Civil and Infrastructure Engineering*, 25(8), 581-595.
- Almahmoud, E. S., Doloi, H. K., & Panuwatwanich, K. (2012). Linking project health to project performance indicators: Multiple case studies of construction projects in Saudi Arabia. *International Journal of Project Management*, 30(3), 296-307
- Bassioni, H. A., Price, A. D. F., & Hassan, T. M. (2005). Building a conceptual framework for measuring business performance in construction: an empirical evaluation. *Construction Management and Economics*, 23(5), 495-507
- Belout, A (1998). Effects of human resource management on project effectiveness and success: toward a new conceptual framework. *International Journal of Project Management* 16(1), 21-26.
- Bertaux, D. (1981). From the life-history approach to the transformation of sociological practice. In *Biography and society: The life history approach in the social sciences*, ed. by D. Bertaux, 29–45. London: Sage.
- Boschman, J. S., van der Molen, H. F., Sluiter, J. K., & Frings-Dresen, M. H. W. (2011). Occupational demands and health effects for brick-layers and construction supervisors: A systematic review. *American Journal of Industrial Medicine*, 54(1), 55–77.
- Brucker, P., Qu, R., & Burke, E. (2011). Personnel scheduling: Models and complexity. *European Journal of Operational Research*, 210(3), 467-473.

- Bureau of Labor Statistics (BLS) (2013). Occupational outlook handbook- Construction and extraction.<http://www.bls.gov>. Accessed: Aug 23, 2014.
- Burleson, R. C., Haas, C. T., Tucker, R. L., & Stanley A (1998). Multiskilled labor utilization strategies in construction. *Journal of Construction Engineering and Management* 124(6), 480-489.
- Caprara, A., Toth, P., Vigo, D., & Fischetti, M. (1998). Modeling and solving the crew rostering problem. *Operations Research*, 46(6), 820-830.
- Cheng, M.-Y., Tsai, M.-H., & Xiao, Z.-W. (2006). Construction management process reengineering: Organizational human resource planning for multiple projects. *Automation in Construction*, 15(6), 785-799.
- Cox, R. F., Issa, Raja R.A., & Frey, A. (2006). Proposed subcontractor-based employee motivational model. *Journal of Construction Engineering and Management*, 132(2), 152-163.
- Creswell, J. W. (1998). *Qualitative inquiry and research design- Choosing among five traditions*. Sage, Thousand Oaks, Calif.
- Demian, P., & Fruchter, R. (2006). An ethnographic study of design knowledge reuse in the architecture, engineering, and construction industry. *Research in Engineering Design*, 16(4), 184-195.
- Dohn, A., Kolind, E., & Clausen, J. (2009). The manpower allocation problem with time windows and job-teaming constraints: A branch-and-price approach. *Computers & Operations Research*, 36(4), 1145-1157.
- Dossick, C. S., & Neff, G. (2010). Organizational divisions in BIM-enabled commercial construction. *Journal of Construction Engineering and Management*, 136(4).
- El-Rayes K., & Moselhi, O. (2001). Optimizing resource utilization for repetitive construction projects. *Journal of Construction Engineering and Management*, 127(1), 18-27.

- Fernie, S., Leiringer, R., & Thorpe, T. (2006) Change in construction: A critical perspective. *Building Research and Information*, 34(2), 91–103.
- Firat, M., & Hurkens, C.A.J. An improved MIP-based approach for a multi-skill workforce scheduling problem. *Journal of Scheduling*, 15(3), 363-380.
- Florez, L. & Castro-Lacouture, D. (2014). Optimal crew design for masonry construction projects considering contractor's requirements and workers' needs. Proceedings of the 2014 ASCE Construction Research Congress, Atlanta, GA, USA, May 19-21.
- Florez, L. & Castro-Lacouture, D. (2015). Optimal crew design for masonry construction projects considering contractor's requirements and workers' needs. Proceedings of the 12th North American Masonry Conference, Denver, CO, USA, May 16-20.
- Florez L, Castro-Lacouture D, and Medaglia A L. (2013). Sustainable workforce scheduling in construction program management. *Journal of the Operational Research Society*, 64(8), 1169-1181.
- Florez, L., Castro-Lacouture, D., & Medaglia, A.L. (2012). Maximizing labor stability as a sustainability performance indicator in project scheduling. Proceedings of the 2012 ASCE Construction Research Congress, West Lafayette, Indiana, USA, May 20-22.
- Florez, L., Castro-Lacouture, D., & Medaglia, A.L. (2011). Program management optimization model using sustainability performance indicators. *Operational Research Society OR53 Conference*, Nottingham, UK, September 6-8.
- Fontana, A., & Frey, J.H. (2005). The interview: From neutral stance to political involvement. In N.K. Denzin & Y.S. Lincoln (Eds). *The sage handbook of qualitative research* (3eds) Thousand Oaks, CA: Sage Publications.

- Gomar, J. E., Haas, C. T., & Morton, D. P. (2002). Assignment and allocation optimization of partially multiskilled workforce. *Journal of Construction Engineering and Management*, 128(2), 103-109.
- Green, S. D., Kao, C.-C., & Larsen, G. D. (2010). Contextualist research-Iterating between methods while following an empirically grounded approach. *Journal of Construction Engineering and Management*, 136(1), 117-126.
- Green, S. D., Larsen, G. D., & Kao, C. C. (2008). Competitive strategy revisited: contested concepts and dynamic capabilities. *Construction Management and Economics*, 26(1), 63-78.
- Guest, G., Bunce, A., & Johnson, L. (2006). How Many Interviews Are Enough?: An Experiment with Data Saturation and Variability. *Field Methods*, 18(1), 59-82
- Harmon, K. M., & Cole, B. (2006). Loss of productivity studies- Current uses and misuses. *Constr. Briefings*, 8(1), 1–19.
- Hartmann, S. (2001). Project scheduling with multiple modes: A genetic algorithm. *Annals of Operations Research*, 102 (1-4), 111-35.
- Hartmann, S., & Briskorn D (2010). A survey of variants and extensions of the resource-constrained project scheduling problem: A Review. *European Journal of Operational Research*, 207 (1), 1-14.
- Hassanein, A., & Melin, J. (1997). Crew design methodology for construction contractors. *Journal of Construction Engineering and Management*, 123(3), 203-207.
- Hegazy, T., & Kamarah, E. (2008). Efficient repetitive scheduling for high-rise construction. *Journal of Construction Engineering and Management*, 134(4), 253-264.

- Heimerl, C., & Kolisch, R. (2010). Work assignment to and qualification of multi-skilled human resources under knowledge depreciation and company skill level targets. *International Journal of Production Research*, 48(13), 3759-3781
- Hesse-Biber, S.N., & Leavy, P. (2006). *The practice of qualitative research*. Thousand Oaks, CA: Sage Publications.
- Horman, M. J., Orosz, M. P., & Riley, D. (2006). Sequence planning for electrical construction. *Journal of Construction Engineering and Management*, 132(4).
- Huemann, M., Keegan, A., & Turner, J. R. (2007). Human resource management in the project-oriented company: A review. *International Journal of Project Management*, 25(3), 315-323.
- Hwang, S., & Liu, L. Y. (2010). Contemporaneous time series and forecasting methodologies for predicting short-term productivity. *Journal of Construction Engineering and Management*, 136(9), 1047-1055.
- Hyaru K, El-Mashaleh M and Kandil A (2010). Optimal Assignment of Multiskilled Labor in Building Construction Projects. *International Journal of Construction Education and Research*, 6 (1), 70-80.
- Jaskowski, P., & Sobotka, A. (2006). Scheduling Construction Projects Using Evolutionary Algorithm. *Journal of Construction Engineering and Management*, 132 (8), 861-870.
- Jun, D. H., & El-Rayes, K. (2010). Optimizing the utilization of multiple labor shifts in construction projects. *Automation in Construction*, 19(2), 109-119.
- Koo, B., Fischer, M., & Kunz, J. (2007). Formalization of construction sequencing rationale and classification mechanism to support rapid generation of sequencing alternatives. *Journal of Computing in Civil Engineering*, 21(6), 423-433.

- Kumar, A., Dijkman, R., & Song, M. (2013). Optimal resource assignment in workflows for maximizing cooperation. *Business Process Management. Lecture Notes in Computer Science*, 8094, 235-250.
- Labuschagne, C., Brent, A. C. & Van Erck, R. P. G. (2005). Assessing the sustainability performances of industries. *Journal of Cleaner Production*, 13(1), 373-385.
- Lee, H.-S., Yu, J.-H., & Kim, S.-K. (2004). Impact of labor factors on workflow. *Journal of Construction Engineering and Management*, 130(6), 918-923.
- Li R K Y & Willis R J (1993). Resource Constrained Scheduling within Fixed Project Durations. *Journal of the Operational Research Society*, 44(1), 71-80.
- Lill I (2008). Sustainable management of construction labour. The 25th international symposium on automation and robotics in construction, Vilnius Lithuania, 864-875.
- Lin, K.-L. (2011). Human Resource Allocation for Remote Construction Projects. *Journal of Construction Engineering and Management*, 27(1), 13-20.
- Lingard H & Sublet A (2002). The impact of job and organisational demands on marital or relationship satisfaction and conflict among Australian civil engineers. *Construction Management and Economics*, 20 (6), 507-521.
- Lloyd, P., & Deasley, P. (1998). Ethnographic description of design networks. *Automation in Construction*, 7(2), 101-110.
- Loosemore M, Dainty A & Lingard, H (2003). *Human Resource Management in Construction Projects: Strategies and operational approaches*. Spon Press: London.
- MacKenzie S, Kilpatrick A R and Akintoye A (2010). UK construction skills shortage response strategies and an analysis of industry perceptions. *Construction Management and Economics*, 18(7), 853-862.

- Marshall, C. & Rossman, G.B. (1999). *Designing qualitative research* (3ed). Thousand Oaks, CA: Sage Publications.
- Maxwell, D. A., Back, W. E., & Toon, J. (1998). Optimization of crew configurations using activity-based costing. *Journal of Construction Engineering and Management*, 124(2), 162-168.
- Mitropoulos, P., & Memarian, B. (2013). Task demands in masonry work: Sources, performance implications and management strategies. *Journal of Construction Engineering and Management*, 139(5), 581-590.
- Mortlock, D. J., & Whitehead, B. (1970). Productivity in brick and block construction - A literature survey. *Building Science* (4), 179–197.
- Ng, S. T., & Tang, Z. (2010). Labour-intensive construction sub-contractors: Their critical success factors. *International Journal of Project Management*, 28(7), 732-740.
- Oral, E. L., & Oral, M. (2010). Predicting construction crew productivity by using Self Organizing Maps. *Automation in Construction*, 19(6), 791-797.
- Orton, J. D. (1997) From inductive to iterative grounded theory: Zip- ping the gap between process theory and process data. *Scandinavian Journal of Management*, 13(4), 419–439.
- Patton, M.Q. (2002). *Qualitative research and evaluation methods* (3ed) Thousand Oaks, CA: Sage Publications.
- Phelps A F, & Horman, M J (2010). Ethnographic theory-building research in construction. *Journal of Construction Engineering and Management*, 136(1), 58-65.
- Pink, S., Tutt, D., Dainty, A., & Gibb, A. (2010). Ethnographic methodologies for construction research: knowing, practice and interventions. *Building Research & Information*, 38(6), 647-659.

- Rajendran, S., Gambatese, J. A., & Behm, M. G. (2009). Impact of Green Building Design and Construction on Worker Safety and Health. *Journal of Construction Engineering and Management*, 135(10), 1058-1066
- Randall, W. S., & Mello, J. E. (2012). Grounded theory: an inductive method for supply chain research. *International Journal of Physical Distribution & Logistics Management*, 42(8-9), 863-880.
- Redmond, A., Hore, A., Alshawi, M., & West, R. (2012). Exploring how information exchanges can be enhanced through Cloud BIM. *Automation in Construction*, 24, 175-183
- Retzlaff, R. C. (2010). Green Buildings and Building Assessment Systems: A New Area of Interest for Planners. *Journal of Planning Literature*, 24(1), 3-21.
- Riley, D. R., & Sanvido, V. E. (1995). Patterns of construction-space use in multistory buildings. *Journal of Construction Engineering and Management*, 121 (4), 464-473.
- Riley, D. R., Sanvido, V., & Mace, B. (2002). Sequence guidelines for mechanical/electrical contractors, Electrical Contractors Foundation, Bethesda, Md.
- Rooke, J., Seymour, D., & Fellows, R. (2003). The claims culture: a taxonomy of attitudes in the industry. *Construction Management and Economics*, 21(2), 167-174
- Sanders, S. R., & Thomas, H. R. (1991). Factors affecting masonry-labor productivity. *Journal of Construction Engineering and Management*, 117(4), 626-643.
- Sarker, B. R., Egbelu, P. J., Liao, T. W., & Yu, J. (2012). Planning and design models for construction industry: A critical survey. *Automation in Construction*, 22, 123-134

- Shehu, Z., & Akintoye, A. (2010). Major challenges to the successful implementation and practice of programme management in the construction environment: A critical analysis. *International Journal of Project Management*, 28(1), 26-39.
- Singh R K, Murty H R, Gupta S K & Dikshit A K (2007). Development of composite sustainability performance index for steel industry. *Ecological Indicators*, 7(2), 565-588.
- Spielholz, P., Davis, G., & Griffith, J. (2006). Physical risk factors and controls for musculoskeletal disorders in construction trades. *Journal of Construction Engineering and Management*, 132(10), 1059–1068.
- Sprecher A & Drexel A (1998). Multi-mode resource-constrained project scheduling by a simple, general and powerful sequencing algorithm. *European Journal of Operational Research*, 107(2), 431-450.
- Srouf I M, Haas C T & Morton D P (2006). Linear Programming Approach to Optimize Strategic Investment in the Construction Workforce. *Journal of Construction Engineering and Management*, 132 (11), 1158-1166.
- Strauss, A., & Corbin, J. (1994). Grounded theory methodology: An overview. *Handbook of qualitative research*, N. Denzin and Y. Lincoln, eds., Sage, Thousand Oaks, Calif.
- Tahir A C & Darton R C (2010). The Process Analysis Method of selecting indicators to quantify the sustainability performance of a business operation. *Journal of Cleaner Production*, 18 (16-17): 1598-1607.
- Thomas, H. R., & Sanvido, V. E. (2000). Role of the fabricator in labor productivity. *Journal of Construction Engineering and Management*, 126 (5), 358–365.
- Trinius, W. (2005). Sustainable construction in ISO/TC59. The 2005 World Sustainable Building Conference, Tokyo, Sep 27-29.

- Turner, R., Huemann, M., & Keegan, A. (2008). Human resource management in the project-oriented organization: Employee well-being and ethical treatment. *International Journal of Project Management*, 26(5), 577-585.
- Ugwu O O & Haupt T C (2005). Key Performance Indicators for Infrastructure Sustainability—A comparative study between Hong Kong and South Africa. *Journal of Engineering, Design and Technology*, 3(1), 30-43.
- Valdes-Vasquez, R., & Klotz, L. E. (2013). Social Sustainability Considerations during Planning and Design: A Framework of Processes for Construction Projects. *Journal of Construction Engineering and Management*, 139(1), 80-89.
- Wong, J. M. W., Chan, A. P. C., & Chiang, Y. H. (2007). Forecasting construction manpower demand: A vector error correction model. *Building and Environment*, 42(8), 3030-3041.
- Wong, J. M. W., Chan, A. P. C., & Chiang, Y. H. (2008). Modeling and forecasting construction labor demand: Multivariate analysis. *Journal of Construction Engineering and Management*, 134(9), 664-672.
- Wongwai N & Malaikrisanachalee S (2011). Augmented heuristic algorithm for multi-skilled resource scheduling. *Automation in Construction*, 20 (4), 429-445.
- Zhang H, Tam C M & Li H (2006). Multimode Project Scheduling based on Particle Swarm Optimization. *Computer-Aided Civil and Infrastructure Engineering*, 21(2), 93-103.
- Zhao, Z.-Y., Zhao, X.-J., Davidson, K., & Zuo, J. (2012). A corporate social responsibility indicator system for construction enterprises. *Journal of Cleaner Production*, 29-30, 277-289.
- Zhu G, Bard J F & Yu G (2005). Disruption management for resource-constrained project scheduling. *Journal of the Operational Research Society*, 56, 365-381.