

AN INVESTIGATION OF THE CHANGE IN MOTIVATION OF FIFTH-GRADE  
STUDENTS ON WRITING ACTIVITIES AFTER BEING TAUGHT COMPUTER  
PROGRAMMING USING SIMILAR TEACHING STRATEGIES

by

Raymond E. Boyles

A dissertation submitted in partial fulfillment  
of the requirements for the degree

of

DOCTOR OF PHILOSOPHY

in

Education

Approved:

---

Gary A. Stewardson, Ph.D.  
Major Professor

---

Edward M. Reeve, Ph.D.  
Committee Member

---

Oenardi Lawanto, Ph.D.  
Committee Member

---

Michael L. Pate, Ph.D.  
Committee Member

---

Matthew Verleger, Ph.D.  
Committee Member

---

Mark R. McLellan, Ph.D.  
Vice President for Research and  
Dean of the School of Graduate Studies

UTAH STATE UNIVERSITY  
Logan, Utah

2014

UMI Number: 3683560

All rights reserved

INFORMATION TO ALL USERS

The quality of this reproduction is dependent upon the quality of the copy submitted.

In the unlikely event that the author did not send a complete manuscript and there are missing pages, these will be noted. Also, if material had to be removed, a note will indicate the deletion.



UMI 3683560

Published by ProQuest LLC (2015). Copyright in the Dissertation held by the Author.

Microform Edition © ProQuest LLC.

All rights reserved. This work is protected against unauthorized copying under Title 17, United States Code



ProQuest LLC.  
789 East Eisenhower Parkway  
P.O. Box 1346  
Ann Arbor, MI 48106 - 1346

Copyright © Raymond E. Boyles 2014

All Rights Reserved

**ABSTRACT**

An Investigation of the Change in Motivation of Fifth-Grade Students on  
Writing Activities After Being Taught Computer Programming  
Using Similar Teaching Strategies

by

Raymond E. Boyles, Doctor of Philosophy

Utah State University, 2014

Major Professor: Dr. Gary Stewardson  
Department: School of Teacher Education and Leadership

Writing is a well-established content area in the elementary grade levels and computer programming is currently being introduced to the elementary grade levels. Both subject areas utilize similar organizational skills and teaching strategies. However, the students who are motivated to program may not represent the students who are motivated to write. The purpose of this study was to investigate the change in the dimensions of motivation, which are: challenge, choice, enjoyment, and interest of fifth-grade students to engage in an expository writing activity after being taught to develop computer programs with the same teaching strategies used in the writing activity.

A quasi-experimental control-group design was conducted, with the use of the *My Class Activities Instrument*, to investigate the change in the dimensions of motivation. Control, treatment groups, and gender were investigated by comparing pretest and

posttest data. The data were analyzed using a multivariate general linear model (MGLM) for treatment/control groups and gender.

The results of the MGLM showed no statistical significance for difference in the control, treatment groups, and gender; more analysis was conducted on individual students. Students were categorized into three levels (low, middle, and high) on motivation by the results of their pretest scores. Students were tracked based on who showed a motivational change from the pretest on both the science activity and the posttest. The individual students in the treatment and control groups were then compared by percentage of individual movement. The results of the analysis showed that the low treatment group, on all four dimensions of motivation, moved more positively than the control group that scored in the low group on the pretest.

The results of this study suggest that the teaching of computer programming was not effective with the intention of motivating the masses of fifth-grade students to write. However, there appears to be supporting evidence that teaching computer programming to fifth-grade students may help some individual students who are not initially motivated to write.

(313 pages)

**PUBLIC ABSTRACT**

An Investigation of the Change in Motivation of Fifth-Grade Students on  
Writing Activities After Being Taught Computer Programming  
Using Similar Teaching Strategies

by

Raymond E. Boyles, Doctor of Philosophy

Utah State University, 2014

The implementation of collaboration and the use of graphic organizers in the teaching of programming and writing in the elementary grades have proven to be effective instructional strategies. There is evidence that shows the students who are motivated to program and perform well in this content area are not necessarily representative of the students who are motivated to write. Since the organizational skills required in the two content areas are similar, there may be an opportunity to motivate students who engage in computer programming to become more motivated in writing. As a result, the purpose of this study was to investigate the change in the dimensions of motivation which are: challenge, choice, enjoyment, and interest of fifth-grade students to engage in an expository writing activity after being taught to develop computer programs with the same teaching strategies used in the writing activity.

The results of this study suggest that the teaching of computer programming was not effective with the intention of motivating the masses of fifth-grade students to write. However, there appears to be supporting evidence that teaching computer programming to fifth-grade students may help some individual students who are not initially motivated to write.

## ACKNOWLEDGMENTS

I would like to thank Dr. Gary Stewardson, who, through long hours, exhibited great patience, leadership, mentorship, and supporting characteristics that I find valuable in the field of education. I would also like to thank the committee members for their patience, hard work, and support that has better prepared me as an academic. I would like to thank my colleagues, Jacob Bishop, Rod Flanigan, Keith Nelson, Trevor Robinson, and Steve Williams, for their help and assistance in the completion of this process.

I would also like to thank my father and mother, Richard and Donna Boyles, and my nephew Richard, for all the phone calls and support that also helped me succeed in this process; and John Rively, who assisted me with many hours of support; Joe Stojan, who is an awesome friend; my cousins, Kenny Ingold and Tom McCray, who provided family support during this process.

Raymond E. Boyles

## CONTENTS

	Page
ABSTRACT.....	iii
PUBLIC ABSTRACT .....	v
ACKNOWLEDGMENTS .....	vi
LIST OF TABLES.....	
LIST OF FIGURES .....	
CHAPTER	
1. INTRODUCTION.....	1
Purpose Statement .....	3
Hypotheses .....	4
Need Statement.....	5
Limitations of the Study .....	6
Assumptions of the Study.....	6
Procedures .....	7
Definition of Terms .....	8
Summary .....	10
2. REVIEW OF THE LITERATURE.....	11
Motivation .....	11
Motivation in Writing.....	13
Motivation in Computer Programming .....	20
Models of Motivation.....	29
Instrument Selection.....	30
Summary .....	32
3. METHODOLOGY .....	33
Study Purpose.....	33
Hypotheses .....	33
Reliability and Validity of the My Class Activity Instrument .....	35
Curriculum.....	35
Development and Piloting of the Curriculum .....	36



	Page
Design Stages .....	38
Data Analysis .....	42
Summary .....	47
4. FINDINGS .....	48
Introduction .....	48
Actual Time Line for Curriculum Delivery and Data Collection .....	49
Statistical Results for Null Hypothesis One .....	49
Mean Differences for Treatment and Control Groups .....	50
Statistical Results for Multivariate GLM on Groups .....	50
Statistical Results for Null Hypothesis Two .....	53
Results for Null Hypothesis Three .....	55
Summary .....	61
5. INTERPRETATIONS, CONCLUSIONS, AND RECOMMENDATIONS .....	63
Introduction .....	63
Conclusions and Recommendations .....	67
Summary .....	68
REFERENCES .....	70
APPENCICES.....	76
Appendix A: IRB Signature Form.....	77
Appendix B: My Class Activities Survey Instrument Answer Sheet.....	81
Appendix C: Core Curriculum .....	84
Appendix D: Programming Curriculum .....	134
Appendix E: Curriculum Workbook .....	170
Appendix F: Tables for Low and High Groups on the Four Dimensions of Motivation .....	290
CURRICULUM VITAE.....	299

## LIST OF TABLES

Table	Page
3-1. Demographics of Control and Treatment Intact Groups.....	35
3-2. Reliability of the Motivational Dimensions for the My Class Activity Instrument .....	36
3-3. Unit: Electrical Controls and Programming .....	37
3-4. Design Stages and Activities .....	39
3-5. Cut-Off Scores for Low, Middle, and High Groups .....	45
4-1. Mean Differences for Groups on the Four Dimensions of Motivation.....	51
4-2. Multivariate Test Results for Groups.....	51
4-3. Between-Subject Results for Groups .....	52
4-4. Mean Difference Results for Gender .....	54
4-5. Multivariate Tests Results for Gender .....	55
4-6. Between Subject Results for Gender .....	56
4-7. Movement of Students in the Pretest Low-Treatment Group on the Dimension of Challenge .....	57
4-8. Movement of Students in the Pretest Low-Control Group on the Dimension of Challenge .....	57
4-9. Movement of Students in the Pretest High-Treatment Group on the Dimension of Challenge .....	58
4-10. Movement of Students in the Pretest High-Control Group on the Dimension of Challenge .....	59
4-11. Low and High Treatment and Control Group Movement on the Four Dimensions .....	60

Table	Page
F1. Movement of Students in the Pretest Low-Treatment Group on the Dimension of Choice .....	291
F2. Movement of Students in the Pretest Low-Control Group on the Dimension of Choice .....	291
F3. Movement of Students in the Pretest High-Treatment Group on the Dimension of Choice .....	292
F4. Movement of Students in the Pretest High-Control Group on the Dimension of Choice .....	293
F5. Movement of Students in the Pretest Low-Treatment Group on the Dimension of Enjoyment .....	293
F6. Movement of Students in the Pretest Low-Control Group on Dimension of Enjoyment .....	293
F7. Movement of Students in the Pretest High-Treatment Group on Dimension of Enjoyment .....	294
F8. Movement of Students in the Pretest High-Control Group on the Dimension of Enjoyment .....	295
F9. Movement of Students in the Pretest Low-Treatment Group on the Dimension of Interest.....	295
F10. Movement of Students in the Pretest Low-Control Group on the Dimension of Interest.....	296
F11. Movement of Students in the Pretest High-Treatment Group on the Dimension of Interest.....	297
F12. Movement of Students in the Pretest High-Control Group on the Dimension of Interest.....	298

**LIST OF FIGURES**

Figure	Page
2-1. Dimensions of motivation as used in the My Class Activity Survey Instrument .....	11
2-2. Motivation and challenge relationship.....	12
3-1. Model .....	40
4-1. Timeline .....	49
5-1. Means for both control and treatment groups on the pretest, science test, and the posttest.....	65

# **CHAPTER 1**

## **INTRODUCTION**

This study focused on two curriculum areas, writing and computer programming; more specifically, expository writing and imperative-computer programming, at the fifth-grade level. Writing has been, and still is, a well-established content area in the elementary grades. Computer programming is in its infancy as a content area but is currently gaining in popularity. Emphasis on science, technology, engineering, and mathematics (STEM) in today's education environment has assisted in the inclusion of programming at the elementary grades. Vendors such as LEGO and more recently VEX, market controllers and programming languages that are age-appropriate for elementary students. To increase student motivation and performance in writing (e.g., expository, narrative, persuasive) and programming (e.g., imperative, declarative, compiled, object orientated), similar instructional strategies are utilized. Although the research identifies similarities in instructional strategies; the students who are successful and motivated in these two areas appear to be different.

For a person to reach his/her full potential, a necessary skill in the 21<sup>st</sup> century is to be able to communicate through writing. "It is clear that the ability to use written language to communicate with others... is more relevant than ever" (U.S. Department of Education, 2012a, p. 1). However, not all students are motivated to write; therefore, these students do not perform at a proficient level in writing. The U.S. Department of Education (2012a) reported that 74% of third- and eighth-grade students in 2011 performed at a basic or below basic level in writing (p. 10). Basic performance "denotes

partial mastery of prerequisite knowledge and skill that are fundamental for proficient work at each grade” (p. 7).

Society’s dependence on technology is increasing. With the growing importance of technology to our society, it is vital that students receive an education that emphasizes technological literacy (International Technology and Engineering Educators Association [ITEEA], 2007). One example of technology literacy is the ability to write, use, manage, access, and understand computers and their applications. Computer programming represents one facet of this broadening goal. Although some schools do not require computer programming experiences, President Obama supported requiring computer programming classes being taught in high schools (White House, 2013). Research has shown that students in middle school who engage in computer programming activities are successful at the programming required to complete their activities (Norton, McRobbie, & Ginns, 2007). Research has also shown that students at the elementary level can learn and have success at writing computer programs (Webb, Ender, & Lewis, 1986).

Research has revealed that both writing and computer programming are taught and developed with an effective strategy known as collaboration (e.g., think-pair-share, buddy system, writing response groups) and an effective organizational tool known as graphical organizers (e.g., thinking maps, sequential concept maps). Collaboration in writing is an effective teaching strategy that increases motivation and performance (Cook, Green, Meyer, & Saey, 2001; Kohnke, 2006; Mason, Meadan, Hedin, & Cramer, 2012). Collaboration in computer programming is an effective teaching strategy that increases motivation and performance (Cockburn & Williams, 2001; Williams, Wiebe,

Yang, Ferzli, & Miller, 2002). The use of graphical organizers in teaching writing increases students' motivation and performance (Chularut & DeBacker, 2004; Garcia & De Caso, 2004; Harris, Graham, & Mason, 2006; Nesbit & Adesope, 2006; Sturm & Rankin-Erickson, 2002). The use of graphical organizers when teaching computer programming increases students' motivation and performance (Hsia & Petry, 1980; Norton et al., 2007; Shneiderman, Mayer, McKay, & Heller, 1977; Weideman & Rawson, 1975). The use of both collaboration and graphic organizers has proven to increase motivation and performance when teaching writing and programming.

Gender is another issue found in both writing and computer programming. In writing, females are more motivated and out perform their male counterparts (Merisuo-Storm, 2006; U.S. Department of Education, 2012b). In the field of computer programming, more males are engaged and participate in computer programming than females in both education and employment (Beyer, Rynes, Perrault, Hay, & Haller, 2003; Forte & Guzdial, 2005; Jiau, Chen, & Ssu, 2009; Nastasi, Clements, & Battista, 1990; U.S. Department of Education, 2012b; Wilder, Mackie, & Cooper, 1985; Wilson & Shrock, 2001). Based on the literature, it appears the students who succeed in writing may represent a different group than those who succeed in the area of programming.

### **Purpose Statement**

The implementation of collaboration and the use of graphic organizers in the teaching of programming and writing in the elementary grades have proven to be effective instructional strategies. There is evidence that shows the students who are

motivated to program and perform well in this content area are not necessarily representative of the students that are motivated to write. Since the organizational skills required in the two content areas are similar, there may be an opportunity to motivate students who are motivated to engage in computer programming to become more engaged in writing. As a result, the purpose of this study was to investigate the change in the dimensions of motivation which are: challenge, choice, enjoyment, and interest of fifth-grade students to engage in an expository writing activity after being taught to develop computer programs with the same teaching strategies used in the writing activity.

### **Hypotheses**

The associated null hypotheses for each research question are as follows.

H1o: There was no significant change in the dimensions of motivation to engage in a writing activity between students who learned computer programming in a collaborative learning environment using a sequential concept map as a graphical organizer and those who did not.

H2o: There was no significant change in the dimensions of motivation to engage in a writing activity within male and female students who learned computer programming in a collaborative learning environment and using a sequential concept map and those who did not.

H3o: There was no change in the dimensions of motivation to engage in a writing activity with individual students who scored in the upper and lower groups on the pretest and who learned computer programming in a collaborative learning environment using a



sequential concept map as a graphical organizer as compared to those who did not.

### **Need Statement**

Although we live in a technological world where automation and processes are controlled by computer systems and most resources can be found on the internet, the skill of writing is still very important. Writing is practical, job related, stimulating, social and therapeutic. Writing is practical. A person who writes can make lists, reminders, and notes. Writing is job-related. Professional workers write frequently, preparing memos, letters, and many other documents. Writing is stimulating. Writing helps to provoke thoughts and organize them. Writing is social. We may write a birthday card or a thank you note. Writing is therapeutic—it allows us to express feelings that cannot be expressed so easily by speaking. However, because of these technological advancements, an increased emphasis on the understanding of computers, their applications, and programming is evident in the K-12 curriculum. Endorsements from President Obama, Bill Gates, and many companies and corporations, are rallying to have computer programming courses taught in the K-12 classroom. Also, with the rise in after-school robotic competitions such as LEGO, VEX, and FIRST, computer programming is being introduced to students as early as the elementary grade levels (Kumar, 2014, p. 20).

The need for students to become more motivated and increase motivation in both subjects is apparent and currently in demand. Because computer programming is in its infancy and with the direction of education and today's technological progress, there may be an opportunity to motivate students in writing through experiences in computer

programming. This opportunity was not available in the past.

### **Limitations of the Study**

This study had six limitations, which aided in defining the scope of the research. Simon and Goes (2013) stated that every study, no matter how well it is conducted and constructed, has limitations (p. 1). The following limitations were inherent in this study.

1. To align this study with the Utah Science Core Curriculum, fifth-grade students were chosen for this study. The science curriculum contains the major components of electricity and magnetism which enables the programming activity as the independent variable. This study was limited specifically to fifth-grade students at two elementary schools in Logan, Utah and the Cache County School District.

2. This study was limited to the LEGO Mindstorms NXT controller.

3. This study was limited to the LEGO NXT imperative-programming language.

4. This study was limited to expository writing.

5. This study was limited to a collaboration teaching strategy known as think-pair-share.

6. This study was limited to sequential concept maps.

### **Assumptions of the Study**

Assumptions were made for this study as they cannot be determined based on observation and experience. Additionally, the study identifies the assumptions to maximize both validity and integrity. The following assumptions were made in this study.

1. Students answered the survey instrument truthfully.
2. The curriculum in writing was the same or similar for the two represented schools.

### **Procedures**

The following procedures were followed in the pursuit of this study:

1. The literature was reviewed in the areas of writing, computer programming, and graphical organizers.
2. The My Class Activities instrument was obtained and reviewed.
3. The curriculum was developed to teach electrical circuits, controls, and programming.
4. The curriculum was piloted.
5. Two elementary schools were selected for the participation of students.
6. The proposal was written.
7. An application to the Internal Review Board (IRB) was submitted and approved (see Appendix A)
8. A meeting was held with English teachers from the two schools to ensure consistency in teaching strategies.
9. Two schools agreed to teach the expository writing with sequential concept maps.
10. The study was conducted and the data gathered.
11. The data received from survey instrument and writing samples was checked

for errors and then analyzed.

12. The results were reported.
13. The conclusions were established.
14. The recommendations were prepared.

### **Definition of Terms**

*Challenge:* One of the four dimensions of motivation, identified in the My Class Activities Survey Instrument, where an individual engages the student and requires extra effort (Gentry & Gable, 2001, pp. 2-4).

*Choice:* One of the four dimensions of motivation, identified in the My Class Activity Survey Instrument, where an individual gives the student the right or power to select educational options and direct his or her own learning (Gentry & Gable, 2001, pp. 2-4).

*Collaborative learning:* A teaching strategy that is both a process innovation and a product innovation that increases students' choices and decisions based on shared knowledge (Lawson, 2004, p. 225).

*Enjoyment:* One of the four dimensions of motivation, identified in the My Class Activity Survey Instrument, where an individual provides the student with pleasure and satisfaction to learn (Gentry & Gable, 2001, pp. 2-4).

*Expository writing:* A method of writing that employs exposition. The employment of exposition is a type of oral or written discourse that is used to explain, describe, give information, or inform (Stanford University, 2013. p. 1)

*Future gain:* Money, rewards, and “perks.”

*Goal theory:* How leaders motivate subordinates to accomplish designated goals (Northouse, 2010, p. 125).

*Graphical organizers:* Graphic organizers, earlier known as structured overviews descended from Ausubel’s advance organizer. Unlike advance organizers that use linear prose, graphic organizers use a spatial format to convey concept relations (Robinson & Kiewra, 1995, p. 455).

*Imperative programming:* A programming paradigm that describes computation in terms of statements that change a programs state. Also this paradigm can use techniques such as subroutines and structure (Goguen & Burstall, 1992, p. 99).

*Interest:* One of the four dimensions of motivation, identified in the My Class Activity Survey Instrument, where a student reflects positive feelings/preference for certain topics, subject areas, or activities (Gentry & Gable, 2001, pp. 2-4).

*Motivation:* A desire or want that energizes and directs goal-oriented behavior (Hunt, 2011, p. 1).

*Sequential concept maps:* Graphical organizers based on eight cognitive skills that utilize visual representation to help students create mental visual patterns for thinking about activities that occur in a sequential manner (Hyerle & Yeager, 2007, p. 7).

*Think-pair-share:* A collaborative teaching strategy where a question is posed to students who were placed in groups of two or three students. The groups discuss and collaborate about the answer (King, 1993, p. 31)

## Summary

The understanding of the relationship between computer programming and writing using collaboration and graphical organizers will help educators determine if computer programming is important with respect to expository writing. This research study examined if there is a change in motivation and performance of fifth-grade students' writing after being taught to develop computer programs with the same teaching strategies used in writing. While the focus of this study was on change in the dimensions of motivation in all students, this study also looked at how the dependent variables: challenge, choice, enjoyment, and interest, are affected within and between students who have been identified at various levels of motivation in writing, in male and female students, and individual students. The importance of this study will assist educators' understanding on how programming activities may influence writing.

## CHAPTER 2

### REVIEW OF THE LITERATURE

#### Motivation

Motivation is a desire or want that energizes and directs goal-oriented behavior (Hunt, 2011, p. 1). According to Gentry and Gable (2001), motivation can be comprised of four dimensions including: challenge, choice, enjoyment, and interest (p. 1). Each construct is defined as follows. *Challenge* is where an individual engages the student and requires extra effort. *Choice* is where an individual gives the student the right or power to select educational options and direct his or her own learning. *Enjoyment* is where an individual provides the student with pleasure and satisfaction. *Interest* is where the students reflect positive feelings/preference for certain topics, subject areas, or activities (Gentry & Gable, 2001, p. 4). As a teacher gains a greater understanding of these four dimensions, they are better enabled to individualize the curriculum to meet the students' motivational needs. These dimensions are illustrated in Figure 2-1.

According to Gentry and Gable (2001), motivating students in the classroom is a

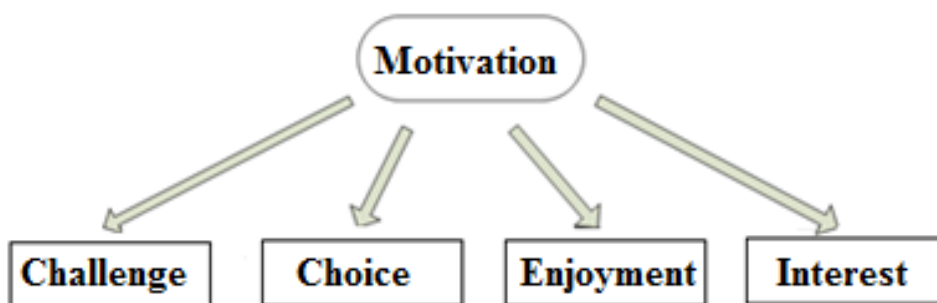

*Figure 2-1.* Dimensions of motivation as used in the My Class Activity Survey instrument (Gentry & Gable, 2001, pp. 2-4).

continual challenge for teachers (p. 1). A student who is more motivated has a greater probability to fulfill the psychological need of competence through performance than a student who is less motivated. One way of motivating students is to set an optimal challenge. The challenges, established by the teacher, should never be too easy or too difficult. Students are attracted to challenges that are slightly beyond their perceived ability level (Deci & Chandler, 1986, pp. 589-590). The relationship between motivation and challenge is illustrated in Figure 2-2.

As challenge increases, motivation increases. Point A illustrates where the challenge is slightly beyond the student's perceived ability level. This area is called optimal challenge. To keep challenge and motivation at the optimum, the teacher has to foster individualism in the curriculum for each student (Deci & Chandler, 1986, p. 590). Promoting challenge, while maintaining student's motivation, can be better accomplished by understanding underlying dimensions of motivation.

Choice affects performance by increasing interest. When a student is given a

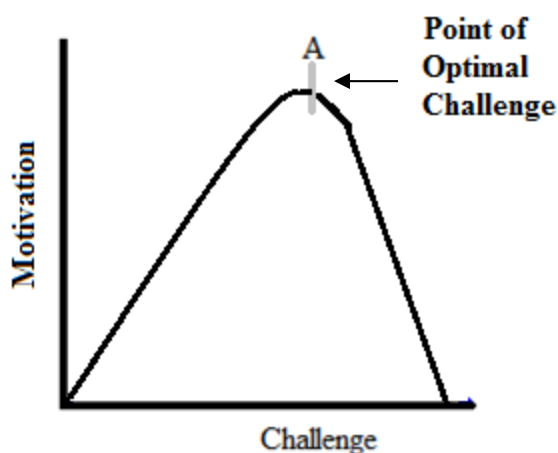

Figure 2-2. Motivation and challenge relationship (Deci & Chandler, 1986, pp. 589-590).



meaningful choice, the challenge may be presented more optimally. While investigating how to increase interest, Schraw, Flowerday, and Lehman (2001) revealed that offering students a meaningful choice increases situation interest (p. 212). It is this choice that engages the student and allows the challenge to be perceived more optimally; hence, performance increases.

Enjoyment affects performance. While investigating the effects of enjoyment on students' learning, Frymier's (1994) study uncovered that student learning was correlated with enjoyment in the classroom (pp. 101-105). If students enjoy classroom interactions, they will tend to be more engaged and focused.

Interest affects performance. If students are not interested, they will not be engaged or focused. Schraw and colleagues' (2001) study also revealed that interest increases learning when a task is original (p. 212). It is increased interest that will employ engagement for performance.

### **Motivation in Writing**

In this paper, an overview of the research in motivation is provided in two different academic contexts and shows how an appropriate intervention might simultaneously improve motivation in both writing and computer programming. Throughout this discussion, it is critical to remember the dimensions of motivation: challenge, choice, enjoyment, and interest, and how these dimensions affect writing activities and learning strategies.

Writing is important and being motivated to write is important; however, some

students are not motivated to write. This review of the literature will show how challenge, choice, enjoyment, and interest are related to factors including: time, gender, goal theory, collaborative projects, and graphical organizers to help improve upon the dimensions of motivation and also gain a better opportunity of increasing motivation in writing.

The search for literature, as it related to writing, uncovered 22 studies, which were included in this literature review. These studies were applicable towards motivation and performance in writing. Of these 22 studies there were nine quantitative and 13 qualitative studies that were included in the body of this study to support this discussion. Exclusion criteria in this search for the literature consisted of subject appropriate studies.

#### Time

The amount of time provided for a student to complete a writing assignment affects the challenge and enjoyment with respect to writing. While exploring students' past and present writing-related experiences, Ballinger (2009) reported that students felt more supported and enjoyed the class when teachers provided plenty of class time to write (p. 25). While exploring students' personal goals, beliefs, and underlying motivations to write, Keil (2001) reported that most classes do not provide enough time to construct a good writing assignment (p. 32).

The amount of class time to write is not the only influence that affects interest and enjoyment to write. Time of year can also affect writing performance when mediated through avoidance motivation. According to Elliot (1999), avoidance motivation can be described as a behavior that is instigated or directed by a negative or undesirable event or possibility (p. 170). While conducting a study on student achievement goals, Meece and

Miller (1999) reported that there is a significant decrease in students' avoidance motivation from the fall to spring term (p. 215).

The amount of time to write and time of the year are important factors that affect challenge and enjoyment with respect to writing. Motivation is influenced based on how much time is offered in a class and the time of year the writing challenge is offered to the student. Challenge and enjoyment affect the students' overall performance through time.

#### Gender

According to the literature, distinction in gender can affect challenge, choice, enjoyment, and interest with respect to writing. While exploring male and female students' attitudes toward reading and writing, Merisuo-Storm (2006) reported that females significantly enjoy writing poetry more than males ( $t = 6.23, p = .000, p < .05$ ) and that females significantly enjoyed writing to a pen pal more than male students ( $t = -5.10, p = .000, p < .05$ ). This study also reported that female enjoyment to write was significantly higher in middle and high school than their male counterparts (pp. 120-122). Considering that females enjoy writing more than males, it is not surprising that the females outperform their male counterparts in writing. The National Center for Education Statistics (NCES) report card stated that females have a significantly higher average writing score than males in 8<sup>th</sup> and 12<sup>th</sup> grade (U.S. Department of Education, 2012b, p. 56). The assessment for this sample was the new national writing assessment administered by the National Assessment of Educational Progress.

Female challenge is optimal in writing because they enjoy, are interested in, and have chosen to participate in writing. Females also achieve higher than their male

counterparts as writers. This is not surprising considering the elevated dimensions of motivation. The literature supports the relationship of motivation and performance through gender.

### **Goals**

Goal theory can be utilized as a teaching strategy. Goal theory affects challenge. Implementation of goal theory in the classroom can increase students' motivation by breaking down a large goal into smaller, achievable goals. Goal theory can be understood as how leaders motivate subordinates to accomplish designated goals (Northouse, 2010, p. 125). While investigating goal theory on students' motivation, Potter, McCormick, and Busching (1994) reported that mastery goals and performance goals do not capture the motivational process (p. 1).

However, Jankauskas (2003) later explored goal setting instruction with writing performance and reported that student scores significantly increased (p. 133). Because students' performance increased, using the goal setting, instructional strategy more optimally presented the challenge. The relationship between optimal challenge and performance reflects that optimal challenge positively affects performance.

### **Collaboration**

Collaboration affects students' challenge, choice, enjoyment, and interest, on both what subject to write about and how to write the subject. Collaboration better enables the student because the students are able to combine ideas that increase the teacher's ability to increase the activities optimal challenge point. The student has more ideas from which

to choose. Most students enjoy talking about their writing with their teacher and colleagues and this helps the student create a more interesting paper to write about. Collaboration is a teaching and learning strategy. According to Lawson (2004), collaboration is an intervention that is both a process innovation and product innovation that increases choices and decisions based on shared knowledge (p. 225). When students collaborate with peers and teachers, more positive results occur with respect to motivation to write. While investigating how to increase motivation to write, Cook and colleagues (2001) reported that very few students in a group almost never share their work while collaborating with peers (p. 61). While investigating student self-motivation to write, Garrett and Moltzen (2011) reported that friends were primarily esteemed as a source of ideas for writing (p. 173). According to this literature, it seems that students desire the opportunity to collaborate. However, Mason and colleagues' (2012) study on students' motivation and their ability to read and write reported that sharing with peers, relative to task perception, did not increase motivation to write (p. 93). Perhaps this study is suggesting that guidelines be set as to how students collaborate because Kohnke's (2006) study of the effects of a writing workshop on students' motivation reported that after collaborating with peers, students were able to choose a topic about which to write. This study also reported that the students' motivation to write was increased because the collaboration allowed the student to make a choice (pp. 100-132).

Students collaborate differently with their parents. Cook and colleagues (2001) reported that the parents argued that their child never shared their work (p. 63). It is the teacher who becomes the collaborator. Kohnke's (2006) study also reported that teacher

interaction increases motivation to write. This interaction helps to prevent the writing assignment from becoming confusing. This study also showed that the post-writing collaboration increased motivation based on audiences' reception to the writing (pp. 108-111). Garret and Moltzen (2011) reported that students place a high value on positive teacher feedback in relation to early writing outputs (pp. 173-174). Collaboration affects four dimensions of motivation. When students collaborate, they can exchange ideas about what to write and how to write it which affect challenge, choice, enjoyment, and interest. This motivation in turn affects performance through collaboration.

### **Graphical Organizers**

Graphical organizers affect challenge, choice, enjoyment, and interest. Similar to goal theory, graphical organizers affect performance by presenting the challenge optimally. Graphical organizers can be presented in the form of sequential concept maps when used in writing (Education Place, 2014). Graphical organizers can also be combined in teaching strategies with collaboration and goal theory.

While investigating graphical organizers on middle school students with learning disabilities, Sturm and Rankin-Ericson (2002) study reported that students who use graphical organizers as a tool increases their knowledge which significantly increases their performance in writing (pp. 132-133). Therefore, training students on graphical organizers becomes an important teaching strategy. While investigating writing as a second language, Chularut and DeBacker's (2004) study significantly revealed that graphical organizers enabled a college class to significantly gain skills in English proficiencies (p. 257).

Tools that help organize, such as outlining or summaries, can be argued as effective teaching strategies; however, a meta-analysis presented by Nesbit and Adesope (2006) revealed that there is evidence that concept mapping is slightly more effective than writing outlines (p. 434). While investigating effects of a motivation intervention for improving the writing of children with learning disabilities, Garcia and de Caso (2004) found that using graphical organizers as part of the motivational strategy increased writing achievement (p. 150). The Harris and colleagues (2006) study showed that using graphical organizers as part of the writing intervention significantly increased student performance. The student performance was measured in terms of length of paper and increased motivation (p. 322).

Graphical organizers allow a large goal to be separated into smaller, manageable goals which affect challenge and help improve goal theory. Because of the modified goals, graphical organizers affect challenge. Although goal theory and collaboration are successful teaching strategies, graphical organizers help classify ideas and communicate the ideas more effectively. Because graphical organizers can be used to outline writing projects which generate ideas both individually and collaboratively, it is no surprise that graphical organizers affect choice. Also, because graphical organizers can be used in problem solving, decision making, studying, research planning, and brainstorming, graphical organizers affect interest and enjoyment. Because of this, challenge, choice, enjoyment, and interest affect performance and motivation to write through graphical organizers.

## **Motivation in Computer Programming**

As mentioned earlier, it is critical to remember the dimensions of motivation when discussing ability, motivation, and performance in any discipline. The next discipline that this literature review will uncover is ability, the dimensions of motivation, and performance on aspects of computer programming. The discipline of computer programming is important and being motivated to engage in computer programming is important because of the advancement of technology. However, some students are not motivated to engage in computer programming. This literature review will reveal how creativity, comfort, future gain, gender, choice, collaboration, and graphical organizers are affected by the dimensions of motivation and how these topics affect an increase or decrease in motivation and performance in the computer programming field.

While conducting the literature review for computer programming as it relates to motivation and performance, 21 studies (16 quantitative and 5 qualitative studies) were included. These studies were applicable towards motivation and performance in computer programming. Selection criteria for the review of programming literature were slightly different than that of the selection criteria for the review of writing literature. This difference is due to the fact that computer programming is in its infancy at the elementary grade level and few studies have been reported for this population. As a result, the consideration of age was not included in the selection criteria for computer programming.

### **Creativity**

Creativity affects challenge, enjoyment, and interest. The nature of the field of



computer programming deals with solving many different types of problems on a daily basis. Some people enjoy the constant changes in problems and the various challenges they represent. These constant changes of problems offer optimal challenge to the programmer which instigates creativity. The challenge of problem solving also creates interest which supports creativity. Because of the nature of the field of computer programming, creativity is an asset. According to Sternberg and Lubart (1998), creativity can be defined as the ability to produce work that is original, unexpected, and appropriate (p. 3). In the field of computer programming, there is much opportunity for creative people. An example of creativity is presented in a study that investigated what motivates “hackers” to engage in computer science. In this study, Lakhani and Wolf (2003) revealed that enjoyment is a significant motivator for computer programming. Their study also showed that allowing students to express creativity in a programming activity significantly increases enjoyment by 41% (pp. 21-23). While investigating urban youth programming motivation, Maloney, Peppler, Kafai, Resnick, and Rusk (2008) showed that creativity allowed sustained engagement in learning while programming at a workshop. Their study reported that creativity attributed for success of the workshop. The students were motivated because they enjoyed applying their own creativity toward the programming activity (pp. 368-370).

Challenge, enjoyment, and interest, are affected through creativity. The field of computer programming deals with solving many different types of problems on a daily basis. People that are engaged enjoy the constant change of different challenges. Problem solving in computer programming also stimulates interest through ever changing

challenges which require creativity. These motivational dimensions: challenge, enjoyment, and interest, affect performance through creativity.

### **Comfort level**

Comfort level affects enjoyment and interest. The level of comfort correlates with anxiety (Hadley & Dorward, 2011). This correlation affects enjoyment and interest which ultimately affects performance. Peoples' educational background can increase or decrease comfort level. Comfort can attribute as to why some students do not enjoy engaging in aspects of computer programming. One reason may be their perceived ability in related subject areas. If a person believes they do not have the ability (e.g., mathematics) required for successful engagement in computer programming, they will have a lower comfort level because the challenge is beyond their perceived ability. Because mathematics is required in computer programming some people will not be engaged because they may feel their mathematical skills are inadequate. While investigating factors that lead to success in an introductory computer programming class, Wilson and Schrock's (2001) study revealed that a math background is a significant contributor of success or failure in computer programming (p. 187). While investigating comfort level in a computer science class, Beyer and colleagues' (2003) study revealed that the level of math and confidence in computer programming are highly-positively correlated (p. 151). While investigating student attributes on success in programming, Byrne and Lyons' study (2001) revealed a significant positive correlation between mathematics points and programming examination scores (p. 50).

Misconceptions about a profession or skill can affect comfort level which may

affect challenge. While investigating attitudes of non-majors in a computer science class, Forte and Guzdial's (2005) study revealed that computer science was perceived as just computer programming (pp. 250-251). This perception affected comfort level because of the misconception. To clarify, the students think that computer programming is sitting at a computer to make the computer carry out tasks when in fact computer science is the study of how computers can be implemented to solve problems and offers much more than just coding programs (e.g., systems analyst, system design).

Altering a class can also affect comfort level. For example, the comfort level of traditional computer-programming students significantly decreased 18.21% when the teacher altered the computer-programming class, from traditional-teaching strategies non-traditional teaching strategies in order to attract students who were not computer-science majors (Forte & Guzdial, 2005, pp. 250-251). Changing the teaching strategy in an attempt to engage non-majors affected the comfort level of the traditional students.

If teachers have an educational or professional background with the skills required to engage in the teaching style for a discipline, they tend to be more comfortable and have a higher probability to be interested in that discipline. This comfort level allows the people to better enjoy the activity. However, if a person does not believe they have the perceived ability to engage, the challenge is beyond optimal, and they will not enjoy or have interest to engage in computer programming. The decreased motivations will negativity affect performance through comfort level.

### **Future Gain**

Rewards (e.g., money, perks) affect choice. Similar intentions of future gain may

affect one's choice to enter a discipline. However, future gain may not correlate with enjoyment. The literature reveals that future gain (e.g., money, lifestyle, rewards) does not attract computer-programming professionals. While investigating motivation of students in programming, Jenkins (2001) study revealed that the aspiration for some future gain is the most common factor as to why students want to engage in computer programming (p. 55). However, while investigating why students who have an aptitude for computer science do not engage, Carter's (2006) study revealed that money had the least influence on choice to engage in computer science. Carter's study also revealed that the students significantly believed they would sit in a chair all day (pp. 29-31). The belief that one who engages in computer science will be sitting in a chair all day decreased motivation to engage as stated earlier as a misconception.

Choice may be affected by money, rewards, and "perks". However, future gain, which affects choice, may not correlate with enjoyment. The decision for engagement in a particular field or discipline is affected by choice and enjoyment through future gain which ultimately affects performance.

## **Gender**

Difference in gender affects challenge, choice, enjoyment, and interest with respect to computer programming. Males, more than females, enjoy and have a greater interest in computer programming. Because of this, it is not surprising that more males choose to enter the field of computer science. Enjoyment is critical for males. For example, more males than females enjoy playing games on the computer. While investigating programming motivation on game-based simulations, Jiau and colleagues'

(2009) study revealed that games significantly motivated males over females to engage in the field of computer science (p. 561). Wilson and Schrock's (2001) study supported that more males than females engage in computer science because they have been reported to play more games on the computer (pp. 187-189). This study seems to correlate computer games with computer programming. While investigating motivation and cognitive growth in programming, Nastasi and colleagues' (1990) study showed that games, in relation to computer science, increased creativity and choice which was evident through the measurements of higher performance (p. 154).

Gaming was not the only choice biased by gender. Forte and Guzdial's (2005) study showed that females believed that computer science was not people oriented, and therefore, they did not enjoy computer science (pp. 250-251). Again, this study is reflecting misconception about the difference between computer programming and computer science. While investigating gender attitudes on computer science, Wilder and colleagues' (1985) study showed that females in K1-12 perceived computer science as masculine. This study is interesting because the males noted that writing was significantly more appropriate for females (p. 218). Females also believed that they would make less money. Beyer and colleagues' (2003) study supported that females would make less money while also supporting the belief that females felt computer science was a more masculine career (pp. 151-153).

More males than females engage in the field of computer science and other fields that require computer programming. According to the U.S. Department of Education (2012a), from 1970 to 2011 more males engaged in the field of computer science and

related fields than their female counterparts. More males engaged in bachelor's degrees and in computer-related fields than females. This report showed that females only accounted for 37% of the total population in computer-related bachelor degrees. In computer-related master degrees, females only accounted for 39% of the total population. In the computer science PhD, females only accounted for 21% of the population (p. 1). In the field of computer engineering and electrical engineering, that ratio of males is greater than the ratio of females. According to Yoder (2011), only 9.4% of women receive their bachelor's degree in the field of computer engineering and only 11.5% of females receive their bachelor's degree in the field of electrical engineering (p. 2). The ability for an individual to write computer programs is essential for success in all three of these fields. More males engaged in these three fields than females.

The literature shows that challenge, choice, enjoyment, and interest are gender biased in both writing and computer programming. This gender bias is evident on which gender engages in computer programming and writing. Because of this, gender affects challenge, choice, enjoyment and interest on the two respective fields.

The literature has shown males enjoy the challenge of computer programming, choose to engage in computer programming, have greater enjoyment in computer programming, and have more interest than females in computer programming. More males than females choose to enter the field of computer programming. Because of the gender bias, the motivational dimensions are affected in the computer related fields through gender.

## **Collaboration**

Collaborative teaching techniques in computer science affect challenge, choice, enjoyment and interest, which in turn affect performance. However, due to computer related fields being relatively new in education, not many studies were conducted to measure the effectiveness of collaboration. However, two studies did support collaborative teaching techniques.

While investigating paired programming in an introductory computer science class, Williams and colleagues' (2002) study showed that course effectiveness can statistically increase when collaboration is used as a teaching strategy (p. 206). Cockburn and Williams (2001) revealed that collaboration can also increase performance. This study reported that the increase in performance was a result of increased enjoyment (p. 4).

Collaboration increases motivation to engage in computer science activities. The collaborative aspect of computer science better enables shared knowledge that allows a greater challenge to be accomplished and also increases choice. The literature also shows that collaboration increases challenge, choice, enjoyment and interest. These four dimensions of motivation in turn affect performance.

## **Graphical Organizers**

Graphical organizers affect performance through challenge, choice, enjoyment, and interest. The teaching strategy of graphical organizers can be applied to the field of computer science in the form of flowcharts (Education Place, 2014). Flowcharts are used to organize and troubleshoot computer programs but can be applied to other logical

problems. When utilized in computer programming or a related field, the use of flowcharts affects the dimensions of motivation both positively and negatively on performance. For example, while investigating the utility of detailed flowcharts in programming, Shneiderman and colleagues (1977) reported that flowcharts do not have a significant effect on composition, comprehension, or troubleshooting ability of students' programs for both flowchart and nonflowchart groups (pp. 375-376). While presenting a paper on how to demonstrate loops in programming, Weiderman and Rawson (1975) argued that flowcharts hamper ability to create structured programming (p. 37). What this study is suggesting is that novices benefit from flowcharts and experts do not.

However, while investigating the effects of graphical organizers in computer science, Hsia and Petry's (1980) study showed that when flowcharts were utilized, computer programmers' ability to produce more computer code with fewer errors increased significantly (p. 231). While investigating problem solving in a robotics class, Norton and colleagues' (2007) study showed that students improved their troubleshooting skills with flowcharts while engaged with a robotic activity. This study also revealed that using flowcharts allowed a large percentage of the class to find an error and fix it (pp. 264-273).

It is important to note that Weiderman and Rawson (1975) argued that flowcharts hinder performance, the studies targeted audiences were computer professionals. Norton and colleagues' (2007) study was targeted toward novices and the use of flowcharts was more valued. This literature supports the use of flowcharts when teaching novices.

When engaged, people can successfully troubleshoot, produce more code, achieve



at a higher level, and become more motivated. This motivation occurs by using flowcharts. These flowcharts are a form of graphical organizers. Therefore challenge, choice, enjoyment, and interest, affect motivation and performance through graphical organizers and collaboration.

### **Models of Motivation**

As mentioned earlier, motivation is a desire or want that energizes and directs goal-oriented behavior (Hunt, 2011, p. 1). There are many motivational theories to consider while investigating motivation (e.g., expectancy-value, attribution theory, and social cognitive theory). Each of these models has their advantages and disadvantages, but these models are very accurate and appropriate in alliance with their scope and audience. For this study the motivational model was established because the instrument, My Class Activities Survey Instrument, was age appropriate and the instrument has been normed and tested with students within grades third through eighth. The My Class Activities Survey Instrument meets the needs of this study because the survey instrument can be used to assess how students view their activities (Gentry & Gable, 2001, p. 1). This model was used to identify how the treatment groups viewed the science activity on the four dimensions of motivation to engage in a writing activity.

In this study there are four dimensions of motivation: which are challenge, choice, enjoyment, and interest that were measured while investigating fifth-grade students' motivation to write. Because the four dimensions of motivation are key components of student learning and student motivation in class activities, this model of

motivation can be measured by the My Class Activities Survey Instrument.

According to Koskinen, Palmer, Codling, and Gambrell (1994), the role of choice in motivation is well recognized. In their study, the children who were more motivated to read were given a choice on what they wanted to read (p. 177). According to Isen and Reeve (2005), when an individual enjoys the activity in which they are engaged, motivation increases (p. 299).

According to Schiefele (1991), an individual who is in a motivational state of being interested in a certain topic, wants to learn more about that topic for its own sake. This interest attributes to motivation (pp. 303-304). These dimensions align with the dimensions supplied in the My Class Activities survey instrument.

### **Instrument Selection**

To enhance this study, an extensive search was conducted including resources from Mental Measurements Yearbook with Test in Print and Google Scholar. The internet and the Merrill-Cazier Library, located at Utah State University, were included as resources in this extensive search. The following five instruments were identified and evaluated.

1. School Motivation and Learning Strategies Inventory
2. California Measure of Mental Motivation Instrument
3. The Self-Concept and Motivation Inventory: What Face Would You Wear?
4. The School Motivation Analysis Test Research Edition
5. My Class Activities Instrument

Exclusion criteria were age appropriateness, and subject appropriateness. Age appropriateness eliminated the (2) California Measure of Mental Motivation Instrument. Subject appropriateness eliminated (1) The School Motivation and Learning Strategies Inventory, (3) The Self-Concept and Motivation Inventory: What Face Would You Wear?, and (4) The School Motivation Analysis Test Research Edition. As a result, the (5) My Class Activities Instrument was selected for this study because it was both age and subject appropriate and fit the motivational model for this study.

The My Class Activities instrument, developed by Marcia Gentry, Ph.D, and Robert Gable, Ed.D, measured students' perception in the four dimensions of motivation discussed earlier (Gentry & Gable, 2001). This instrument is appropriate for measuring the dimensions of motivation of students from the third to sixth grade. The My Class Activities instrument consists of 31 items. Eight items are used to measure the construct of interest, nine items measure the construct of challenge, seven items measure the construct of choice, and seven items measure the construct of enjoyment. All items are presented utilizing a 5-point Likert scale (see Appendix B). This instrument has been used in other studies. For example, a study was conducted that measured motivation. The My Class Activities Instrument tested how teacher's practices influence student outcomes in reading instruction for advanced readers (Hunsaker, Nielsen, & Bartlett, 2010, pp. 273-282). Another study that used this instrument was a comparison of middle school student motivation and preference toward text and graphic-based programming (Williams, 2009). A search conducted on Google Scholar revealed over 900 uses including studies and publications that use or cite the My Class Activities instrument.

## Summary

The literature shows that writing and computer programming share similar factors and teaching strategies that align with writing and computer programming. These factors include graphical organizers, collaboration, and gender. The literature also shows that teaching strategies in both writing and programming require a similar organizational skill set. In addition, the literature shows that students who succeed in writing may represent a different group than those who succeed in the area of computer programming. As a result, it is believed that we can motivate students by teaching expository writing by using imperative programming through the use of the same teaching strategies and organizational skills. If this theory is correct, this study will help motivate students by the integration of computer programming and writing in the elementary schools.

## **CHAPTER 3**

### **METHODOLOGY**

#### **Study Purpose**

The purpose of this study was to investigate the change in the dimensions of motivation which are: challenge, choice, enjoyment, and interest of fifth-grade students to engage in an expository writing activity after being taught to develop computer programs with the same teaching strategies used in the writing activity. The literature shows that the implementation of collaboration and the use of graphic organizers in the teaching of programming and writing in the elementary grades have proven to be effective instructional strategies. The literature also indicates that the students who are motivated to write computer programs and perform well in this content area are not necessarily representative of the students who are motivated to write. The following null hypotheses will be investigated by the methods described in this chapter. The associated null hypotheses for each research question are as follows.

#### **Hypotheses**

H1o: There was no statistical change in the dimensions of motivation to engage in a writing activity between students who learned computer programming in a collaborative learning environment using a sequential concept map as a graphical organizer and those who did not.

H2o: There was no statistical change in the dimensions of motivation to engage in

a writing activity within male and female students who learned computer programming in a collaborative learning environment and using a sequential concept map and those who did not.

H3o: There was no change in the dimensions of motivation to engage in a writing activity with individual students who scored in the upper and lower groups on the pretest and who learned computer programming in a collaborative learning environment using a sequential concept map as a graphical organizer as compared to those who did not.

### **Population**

The population for this study was from two schools in Cache County, Utah. Two schools were selected as a convenience population. The two schools were selected due to their close proximity to Utah State University. From each school one class was selected as the control group and one class was selected as the treatment group. Because of the nature of the science core curriculum appropriateness, fifth-grade students were selected in two schools. The selected fifth-grade classes in the two schools were comprised of 121 fifth-grade students. Gender was identified by the teacher in the two respective schools. A mixed method experimental pretest-posttest control-treatment design was used in this study with intact groups. According to Dimitrov and Rumrill (2003), nonrandomized control group pretest/posttest designs do not interrupt the existing research setting (p. 160). It is the noninterruption that reduces risk to external validity. However, risk to internal validity becomes more sensitive. Although randomization of the students at each school would reduce internal validity, randomization could not be accomplished due to intact groups. The schools' *N* size and demographics are illustrated in Table 3.1.

Table 3-1

*Demographics of Control and Treatment Intact Groups*

School/group	Gender		<i>n</i>
	Male	Female	
Edith Bowen Laboratory School			
Control	13	13	26
Treatment	14	13	27
Canyon Elementary			
Control	15	15	30
Treatment	20	18	38

### **Reliability and Validity of the My Class Activity Instrument**

The internal validity score of the My Class Activities instrument was based on data obtained from 1,523 student respondents from 61 classrooms. Validity data were based on the Tucker-Lewis “goodness of fit index with a score of .88, a mean root square residual of .09” (Gentry & Gable, 2001, p. 23). Generally, values at or above a .90 are considered an excellent fit. The reliability coefficients for the My Class Activities instrument’s Cronbach’s alpha ranged from .66 to .74 and are represented in Table 3.2. Nunnaly (1978) indicated that a score of .70 alpha to be an acceptable reliability coefficient but lower thresholds are sometimes used in the literature (pp. 898-899).

### **Curriculum**

The curriculum administered in this study consisted of two expository writing activities, a science activity (electricity and magnetism) with an interpretive-

Table 3-2

*Reliability of the Motivational Dimensions  
for the My Class Activity Instrument*

Scale	Reliability estimate
Interest	.70
Challenge	.66
Choice	.67
Enjoyment	.74

*Note.* Reliability scores are Chronbach's alpha.

programming emphasis accompanied by a workbook, and the same science activity (electricity and magnetism) without the interpretive-programming emphasis which is also accompanied by a workbook (see Appendices C, D, and E). The expository writing activity was taught by the fifth-grade English teachers from both schools. This writing activity was derived by the Utah State Standards to ensure grade level appropriateness. The science activity with the interpretive programming emphasis and the science activity without the programming emphasis that covers lessons 1-8 (see Appendices D and E) were taught by the researcher. The science content was derived from the Utah State Standards and follows the outline illustrated in Table 3-3.

### **Development and Piloting of the Curriculum**

A curriculum was developed by the researcher for the science activity with the imperative programming emphasis. This curriculum was developed based on Utah's Science Core Curriculum, which covers fifth-grade electricity and controls (Utah State Board of Education [USBE], 2002, p. 9). Terminal objectives were identified along with



Table 3-3

*Unit: Electrical Controls and Programming*

Lesson #	Content
1	Light a light bulb
2	Follow safety practices
3	Test for Conductivity
4	Electrical properties and components
5	Wire a simple circuit
6	Wire a series circuit
7	Wire a parallel circuit
8	Wire a mechanical relay
9	Write a program to turn on individual outputs
10	Write a program to control a traffic light
11	Write a program to control a traffic light based on the input of a switch
12	Write a program to control a Ping-Pong ball feeder
13	Write a program to control a Ping-Pong ball feeder based on inputs

*Note.* Outline of the (treatment) curriculum.

the necessary enabling objectives. Formative and summative assessments to measure these objectives were developed and activities were also developed to teach the objectives outlined in the lesson plans (see Appendices C, D, and E). Next, the curriculum was piloted in two phases. In the first phase, 26 fifth-grade students from Edith Bowen Laboratory School were taught the science activity without the programming emphasis which was derived from core curriculum.

The curriculum covered electricity and magnetism in the first eight lessons (see Table 3-3). In the second phase, 21 4-H students were taught the science activity with the imperative-programming emphasis, which covered lesson 1-13. The results of piloting the curriculum uncovered needed modifications. For example, Lesson 3: Test for

Conductivity was originally Lesson 4; Lesson 4: Electrical properties and components was originally Lesson 3. These two lessons were switched after it was discovered that having two lessons that were lecture based, Lesson 2: Follow Safety Practices and the original Lesson 3: Electrical Properties and Components, made it difficult to keep the students engaged early on in this activity. Switching these two lessons allowed there to be a minimum of only one lecture based lesson between the more engaging hands-on based lessons. Later in the activity, this was no longer a problem since the lessons were primarily designed around hands-on learning.

### **Design Stages**

The quasi-experimental design pretest posttest on expository writing, in addition to the test on programming, consists of six stages and is illustrated in Table 3.4.

### **Model**

As illustrated in Figure 3-1, the following activities demonstrate the methodology of this study. This model demonstrates the events that occurred in this study,

An expository writing activity was administered to the students in both the treatment and control groups after the writing activity. This writing activity was taught with the aid of collaboration (think-pair-share) and graphical organizers (thinking maps, sequential concept maps).

### **Instrument**

The My Class Activities instrument was administered to both the control groups

Table 3-4

*Design Stages and Activities*

Stage	Activity
1	The expository writing activity was taught with the aid of collaboration (think-pair-share) and graphical organizers (thinking maps, sequential concept maps) to both the control and treatment groups.
2	A pretest on the dimensions of motivation (challenge, choice, enjoyment, and interest) of the expository writing activity was conducted using the My Class Activities instrument on both the control and treatment groups for the purpose of a benchmark.
3	The science activity, with an imperative programming emphasis, was taught to the treatment groups with the aid of collaboration (think-pair-share) and graphical organizers (thinking maps, sequential concept maps). During this activity, the similarities between expository writing and imperative programming with the use of collaboration (think-pair-share) and graphic organizers (thinking maps, sequential concept maps) was pointed out to the students in the treatment groups throughout the lesson. Also, during this period the same science activity without the programming emphasis was taught to the control groups.
4	A test was conducted on students' motivation (challenge, choice, enjoyment, and interest) of programming, in the treatment groups, using the My Class Activities instrument, and a test was conducted on students' motivation of control groups using the My Class Activities instrument.
5	The expository writing activity, with the aid of collaboration (think-pair-share) and graphical organizers (thinking maps, sequential concept maps), was administered to both the control groups and the treatment groups. During this activity the similarities between writing and programming with the use of collaboration and graphic organizers was pointed out to the students in the treatment groups throughout the lesson. The similarities were pointed out through the curriculum and verbally by this researcher.
6	Posttest both the control and treatment groups using the My Class Activities instrument.

*Note.* Outline of this study's model.

and the treatment groups after the first writing activity. The purpose of the pretest was to establish baseline data that indicated to what level students were motivated to engage in expository writing. At this time, the teacher identified gender and listed the information on the individual student's tests.

### **Core Curriculum**

Both the control and the treatment groups were taught the electricity and magnetism portion of the science curriculum activity. This portion of the curriculum

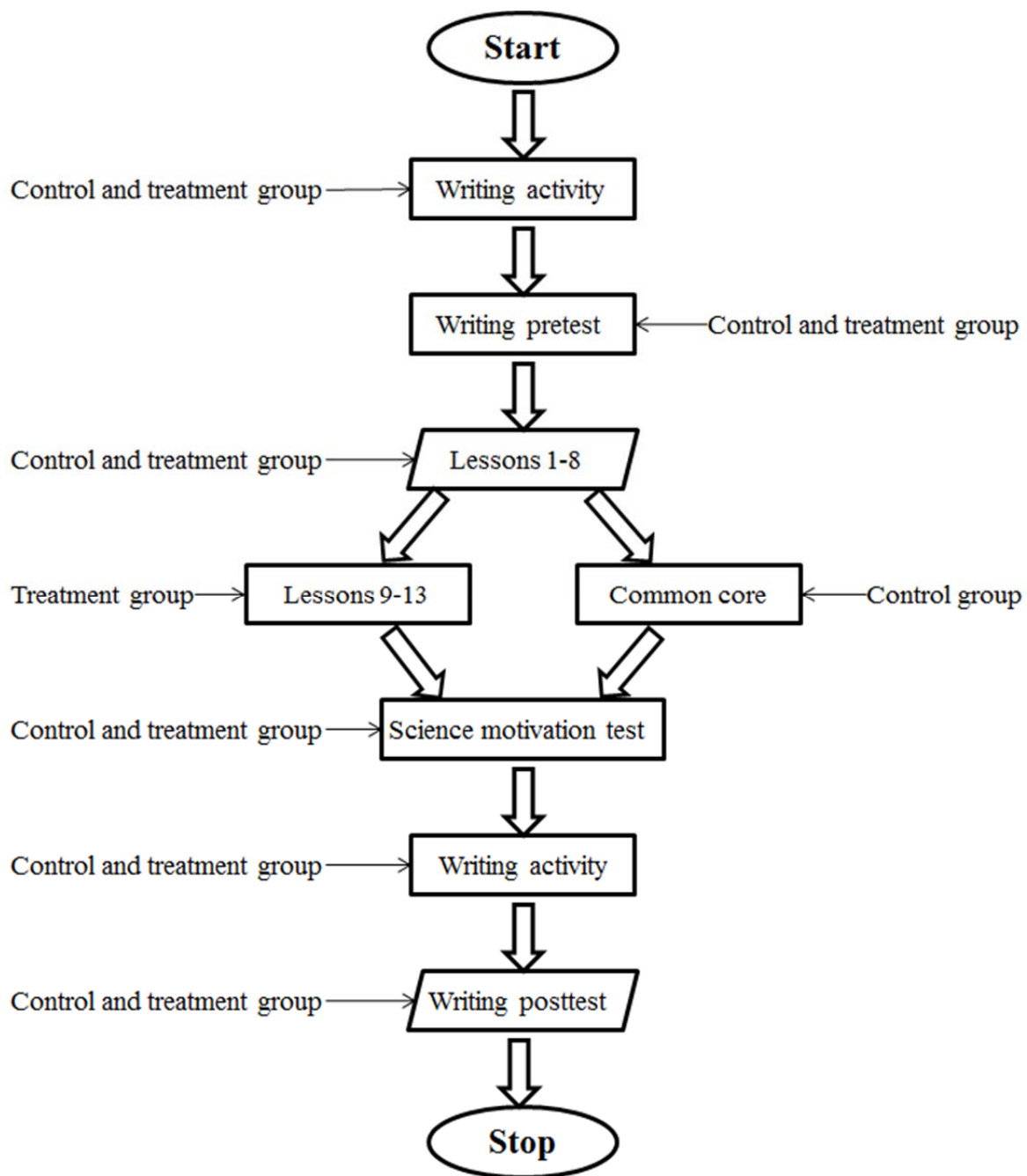

Figure 3-1. Model.

consisted of Lessons 1-8 as listed in Table 3.3. This activity was taught with the aid of collaboration (think-pair-share) and hands-on activities.

### **Group**

The control and treatment groups were then separated by classes and assigned into cooperative learning groups. The control group was taught a core curriculum science lesson while the treatment group was taught the same core curriculum with an imperative programming section of the science activity. The lessons included in the programming activity consisted of Lesson 9-13 as listed in Table 3-3. During the activity with the treatment group, graphical organizers (flowcharts) would be identified to the students as having an organizational relationship to graphical organizers (sequential concept maps) that the students use to write an expository paper. The method of identifying this information to students was both formal (in the curriculum) and informal (verbal) by the researcher. For example, the students were told that the flowcharts they used to write their software had similar functionality as does the graphical organizers (thinking maps, sequential concept maps) that the students use in their expository writing assignments.

### **Motivation in Science**

The My Class Activities instrument was administered to the treatment groups and the control groups. The purpose was to measure the dimensions of motivation to engage in the imperative programming portion of the curriculum. At this time, the teacher identified gender and listed the information on the individual student's tests. An expository writing activity was taught to the students. This expository writing activity

was taught with the aid of collaboration (think-pair-share) and graphical organizers (thinking maps, sequential concept maps) to both the control groups and the treatment groups. During this activity, the similarities between expository writing and interpretive programming with the use of collaboration (think-pair-share) and graphic organizers (thinking maps, sequential-concept maps) were pointed out to the students in the treatment groups throughout the lesson. The similarities were pointed out verbally.

### **Posttest**

The My Class Activities Survey was administered to all the students. The purpose of this posttest was to measure the four dimensions of students' to engage in an expository writing activity. At this time the teacher identified gender and listed the information on the student's tests.

### **Data Analysis**

The following variables in this study will be identified: independent variables, moderating variables, and the dependent variables. The independent variables in this study were the programming curriculum and methods (flowcharting and collaboration). The moderating variables in this study were: gender (1 = male, 2 = female), group (1 = treatment, 2 = control), and motivation groups (1 = low, 2 = middle, 3 = high) with 1 being lowest-motivational writing or science score and 3 being highest motivational writing or science score. Gender was identified by the teacher and labeled on the My Class Activity Survey answer sheet. The dependent variables were challenge, choice, enjoyment, and interest. The survey is presented on a Likert scale and measured upon the

four dimensions of motivation. Each of the dimensions of motivation were measured on a scale from 1 to 5 with the following representations: 1 = never, 2 = seldom, 3 = sometimes, 4 = often, and 5 = always with respect to the four dimensions of motivation.

After the My Class Activity Survey was completed three times by the students the survey was inspected for completeness. A team of two college students inspected the data, which was coded prior to the inspection by the college students, on two different Microsoft Excel data sheets. Both sheets were compared by the criteria of (same/different) using a programming technique built into Microsoft Excel. Any discrepancy that was found was compared to the original data, and the corrections to the data were made. The team also verified each of the data individually and compared their results. All data and all statistical tests were verified with the use of Mat Lab. SPSS also accounted for testing errors. For example, if a student did not fully participate in the study, SPSS accounted for this student. Also, if a student answered twice on one question, the verifiers and the researcher counted that question as not answered. This question was later accounted for by SPSS.

The first null hypothesis states that there was no significant change in the dimensions of motivation to engage in a writing activity between students who learned computer programming in a collaborative learning environment using a sequential concept map as a graphical organizer and those who did not. The second null hypothesis states that there was no significant change in the dimensions of motivation to engage in a writing activity with each of the levels of students who learned computer programming in a collaborative learning environment using a sequential concept map as a graphical

organizer. Both of these null hypotheses were investigated with the following analysis.

The method to investigate these two hypotheses was to analyze the data using SPSS with a 2x2 multivariate general linear model (MGLM). A MGLM was selected because there was more than one dependent variable in this model. In this study, there are four dependent variables (challenge, choice, enjoyment, interest). According to IBM, authors of SPSS, the MGLM procedure provides regression analysis and analysis of variance for multiple dependent variables by one or more factor variables or covariates (IBM, 2012). A MGLM can be used when a design is a simple one-way design or with a more complex design where there is more than one independent variable or factor (Brace, Kemp, & Snelgar, 2012, p. 314).

A MGLM consists of several tests including Box's test of equality of covariance matrices, partial eta squared, Levene's test of equality of error variance, multivariate, and sums of squares. To test whether the data violates the assumption of homogeneity of variance-covariance matrices, Box's test of equality of covariance matrices was conducted. If the value is significant, then the violation has occurred (Brace et al., 2012, p. 316). Partial eta squared values were used to provide an indicator of the proportion of variance in the combined dependent variables that can be accounted for by the independent variable group matrices (Brace et al., 2012, p. 316). Levene's test of equality of error variance was also conducted. This test signifies if the variance can be assumed equal or not equal matrices (Brace et al., 2012, p. 317). The Type III sums of squares was also reported to show the sum, over all observations of the differences squared of each observation on the dependent variable between the independent variables from the



overall mean matrices (Cohen, 2008, p. 54). Because no statistical significance was found on the MGLM, a *t* test was not conducted.

### **Low, Middle, and High Groups**

Null hypothesis three states that there was no change in the dimensions of motivation to engage in a writing activity with individual students who scored in the upper and lower groups on the pretest and who learned computer programming in a collaborative learning environment using a sequential concept map as a graphical organizer as compared to those who did not. The approach to investigate this hypothesis consists of creating three groups from the data (low, medium, and high) and analyzing the low and high groups' movement through the other two activities on the four dimensions of motivation. Groups were determined using cut-off scores defined by Gentry and Gable's database:  $N = 1,523$  (Gentry & Gable, 2001, pp. 24-50). Each dimension in the Gentry and Gable's My Class Activity Survey Instrument has different cut-off scores. These cut-off scores are illustrated in Table 3-5. Because of the cut-off scores being supplied by the database used by Gentry and Gable, the  $N$  size for the low, medium, and high groups, in this study, did not have an equal number of students.

Table 3-5

#### *Cut-Off Scores for Low, Middle, and High Groups*

Dimension	Low group	Medium group	High group
Challenge	< 3.13	3.13 to 3.94	> 3.94
Choice	< 2.69	2.69 to 3.69	> 3.69
Enjoyment	< 3.23	3.13 to 4.54	> 4.54
Interest	< 3.07	3.13 to 4.07	> 4.07

Hypothesis three investigated individual students identified in the low group on the pretest who scored in the middle or high group on the posttest after scoring into the middle or high group on the science test. Students that meet this criterion would have lower motivation in the dimensions challenge, choice, enjoyment, and interest to engage in the writing activity. However, the individual student may have increased motivation on the post-writing activity because they may have been motivated on the science activity. Because of this motivational increase during the science activity and the similarities in the teaching and organizational skills in both programming and writing, the treatment group of the science activity may have increased their individual motivation on the post-test writing activity. This study then compared the percentage of movement of individuals meeting the criteria in the treatment group to those students meeting the criteria in the control group to assist in determining if this movement was a possible result of the treatment.

Conversely, this study investigated individual students identified in the high group on the pretest who moved negatively on the posttest after scoring low on the science test to see if the treatment impacted individual students negatively. The percentages of the movement were compared with the treatment group to those in the control group which assisted in determining if this movement was a possible result of the treatment.

Students who had not completed all phases of the study were kept in the data for null hypothesis one and two. For null hypothesis three, this would have been inappropriate since the movement is being tracked by individual students.

## Summary

The purpose of this study was to investigate the change in the dimensions of motivation which are: challenge, choice, enjoyment, and interest of fifth-grade students to engage in an expository writing activity after being taught to develop computer programs with the same teaching strategies used in the writing activity. Identified in the chapter were the following: study purpose and research questions, population and participants, design stages, curriculum, pilot study, reliability and validity of the My Class Activities instrument, data analysis, statistical power, and hypothesis three. Using the statistical analysis and qualitative analysis described in the section, the three null hypotheses will be investigated.

## **CHAPTER 4**

### **FINDINGS**

#### **Introduction**

The purpose of this study was to investigate the change in the dimensions of motivation which are: challenge, choice, enjoyment, and interest of fifth-grade students to engage in an expository writing activity after being taught to develop computer programs with the same teaching strategies used in the writing activity. To fulfill this purpose, the following null hypotheses were tested:

H1o: There was no significant change in the dimensions of motivation to engage in a writing activity between students who learned computer programming in a collaborative learning environment using a sequential concept map as a graphical organizer and those who did not.

H2o: There was no significant change in the dimensions of motivation to engage in a writing activity within male and female students who learned computer programming in a collaborative learning environment and using a sequential concept map and those who did not.

H3o: There was no change in the dimensions of motivation to engage in a writing activity with individual students who scored in the upper and lower groups on the pretest and who learned computer programming in a collaborative learning environment using a sequential concept map as a graphical organizer as compared to those who did not.

### Actual Time Line for Curriculum Delivery and Data Collection

For this study, the procedure model (see Figure 3-4) outlined in Chapter 3 was followed. However, implementing this model with two different schools and with various un-anticipated interruptions (e.g., fire drills, standardized testing) would be difficult to forecast. The Gantt chart below (see Figure 4-1) illustrates the actual time-line of events during this study with both schools.

### Statistical Results for Null Hypothesis One

#### Descriptive Statistics

The first null hypothesis states that there will be no significant change in the dimensions of motivation to engage in a writing activity between students who learned computer programming in a collaborative learning environment using a sequential concept map as a graphical organizer and those who did not. This null hypothesis was

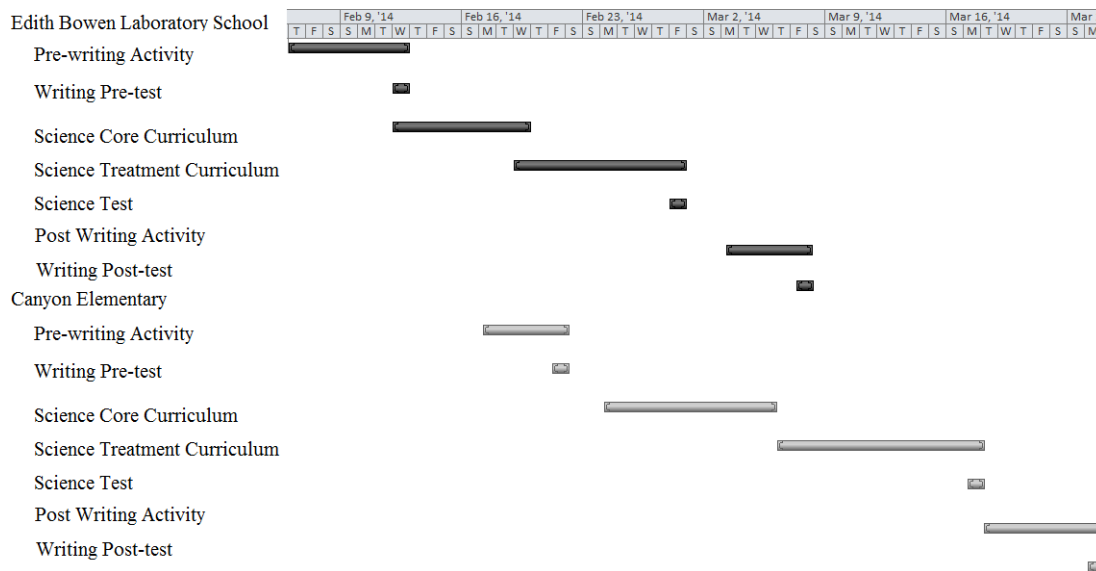

Figure 4-1. Timeline.

tested with 121 students. However, because of absenteeism, only 96 out of 121 students completed the pretest, science, and posttest. For all four dimensions the treatment group had an  $N$  size of 46 and the control group had an  $N$  size of 50, for a total  $N = 96$ .

To test null hypothesis one, the means difference and standard deviation differences between the posttest and pretest were reported from the control and treatment groups. Next, a MGLM was used to evaluate the data. The purpose of utilizing the mean difference and the standard deviation difference was to gain an indication of the movement between the treatment and control groups from the pretest to the posttest. The purpose of utilizing the MGLM was to identify the effect of the two independent variables (group and gender) and how the independent variables interacted between and within the four dependent variables.

### **Mean Differences for Treatment and Control Groups**

The reported mean differences and standard deviations differences with standard error of both the control and treatment groups are illustrated in Table 4-1. For the dimension of challenge, the treatment group had a mean difference between the pretest and the posttest of  $-.11$  with a standard deviation difference between the pretest and the posttest of  $.52$ . The control group had a mean difference of  $-.19$  with a standard deviation difference of  $.40$ . Choice, enjoyment, and interest are reported in Table 4-2.

### **Statistical Results for Multivariate GLM on Groups**

Further investigation into  $H_{10}$  was to conduct by using a MGLM. On the

Table 4-1

*Mean Differences for Groups on the Four Dimensions of Motivation*

Dimension	Group	<i>n</i>	Mean difference	SD difference	<i>SE</i>
Challenge	Treatment	46	-.11	.52	.08
	Control	50	-.19	.40	.06
Choice	Treatment	46	-.22	.86	.13
	Control	50	-.39	.70	.10
Enjoyment	Treatment	46	-.39	.83	.12
	Control	50	-.32	.64	.09
Interest	Treatment	46	-.31	.83	.12
	Control	50	-.40	.75	.11

Table 4-2

*Multivariate Test Results for Groups*

Independent variables	Statistic	Value	<i>F</i>	Hypothesis <i>df</i>	Error <i>df</i>	Sig.	Partial Eta squared
Group	Pillai's trace	.05	1.01	4.00	89.00	.41	.04

dimensions of motivation with Groups, there are several test associated with a MGLM. In this study the test included: Box's test of equality of covariance matrices, Levene's test of equality of error variance, multivariate, and between subjects.

To test whether the data violates the assumption of homogeneity of variance-covariance matrices, Box's test of equality of covariance matrices was conducted. If the value is significant, then the violation has occurred (Brace et al., 2012, p. 316). The test results were  $F(30, 21300.97) = 1.28, p < .001$ , and  $p = .14$ . These results were not significant; therefore, the assumption of homogeneity is valid.

The multivariate test results are illustrated in Table 4-2. Partial eta squared values for groups on all four dimensions were reported. The value of the Partial Eta Squared for all four statistical tests was .04. There are four tests that accompany the MGLM (Pillai's trace, Wilks' lambda, Hotelling's trace, and Roy's largest root). Pillai's trace was reported because of the variance found in Levene's test of equality of error variances on the dimension of challenge;  $F(4,89) = 1.01, p < .05. p = .41$ . Levene's test of equality of error variances was also included in the MGLM for the purpose of conducting a test of homogeneity

The test signifies if the variance can be assumed equal or not equal matrices (Brace et al., 2012, p. 317). For the dimension of challenge,  $F(3,92) = 3.22, p = .026$ , which is significant and assumes unequal variances.

The between-subject effects are illustrated in Table 4-3. The Type III sums of squares was also reported to show the sum, overall observations, of the differences squared of each observation of the dependent variable between the independent variables from the overall mean matrices (Cohen, 2008, p. 54).

Table 4-3

*Between-Subject Results for Groups*

Source	Dependent variable	Type III sum of squares	df	Error	Mean square	F	Sig.	Partial eta squared
Group	Challenge	.19	1	92	.19	.88	.35	.01
	Choice	.80	1	92	.80	1.30	.26	.01
	Enjoyment	.11	1	92	.11	.20	.66	.00
	Interest	.23	1	92	.23	.37	.54	.00



## Statistical Results for Null Hypothesis Two

### Statistical Procedures

The second null hypothesis states that there will be no significant change in the dimensions of motivation to engage in a writing activity within male and female students who learned computer programming in a collaborative learning environment and using a sequential concept map and those who did not.

This question was tested with a total  $N$  of 96. For all four dimensions, the treatment group of males had an  $N$  of 26 and the control group of males had an  $N$  of 25, for a total of 51 males. The treatment group of females had an  $N$  of 20 and the control group of females had an  $N$  of 25, for a total of 45 females.

### Means and Standard Deviation Difference

Mean and standard deviation difference were again reported for the independent variable gender. The reported mean and standard deviation differences of both the control and treatment groups are illustrated in Table 4-4.

For the dimension of challenge, the males in the treatment group had a mean difference between the pretest and the posttest of  $-.14$  with a standard deviation difference of  $.62$ . For the dimension of challenge, the males in the control group had a mean difference between the pretest and the posttest of  $-.15$  with a standard deviation difference of  $.44$ . For the dimension of challenge, the females in the treatment group had a mean difference between the pretest and the posttest of  $-.06$  with a standard deviation difference of  $.37$ . For the dimension of challenge, the females in the control group had a

Table 4-4

*Mean Difference Results for Gender*

Dimension	Gender	Group	Mean difference	SD difference	N
Challenge	Male	Treatment	-0.14	0.62	26
		Control	-0.15	0.44	25
	Female	Treatment	-0.06	0.37	20
		Control	-0.24	0.37	25
Choice	Male	Treatment	-0.25	0.79	26
		Control	-0.45	0.8	25
	Female	Treatment	-0.17	0.96	20
		Control	-0.34	0.59	25
Enjoyment	Male	Treatment	-0.42	0.92	26
		Control	-0.42	0.65	25
	Female	Treatment	-0.36	0.72	20
		Control	-0.23	0.62	25
Interest	Male	Treatment	-0.36	0.88	26
		Control	-0.53	0.82	25
	Female	Treatment	-0.24	0.77	20
		Control	-0.26	0.67	25

mean difference between the pretest and the posttest of -.24 with a standard deviation difference of .37. Choice, enjoyment, and interest are also reported in Table 4-6.

A MGLM was used to test the dimensions of motivation with gender. To test whether the data violates the assumption of homogeneity of variance-covariance matrices, Box's test of equality of covariance matrices was conducted. The test results were the same as for group because group and gender are part of the same MGLM. The test results were  $F(30, 21300.97) = 1.28, p < .001, p = .14$ . Because this result is not significant, the data did not violate the assumption of homogeneity.

The multivariate test results are illustrated in Table 4-5. Partial eta-squared values

Table 4-5

*Multivariate Tests Results for Gender*

Effect	statistical test	Value	<i>F</i>	Hypothesis <i>df</i>	Error <i>df</i>	Sig.	Partial eta squared
Gender	Pillai's trace	.021	.46	4.00	89.00	.76	.02

for groups on all four dimensions were reported. The value of the partial eta squared for all four statistical tests was .02. There are four tests that accompany the MGLM. These include Pillai's trace, Wilks' lambda, Hotelling's trace, and Roy's largest root;  $F(4,89) = .46, p < .05. p = .76$ . Pillai's trace was used because of the results of Levene's test of equality of error variances.

Levene's test of equality of error variances was also included in the MGLM for the purpose of conducting a test of homogeneity. For the dimension of challenge:  $F(3,92) = 3.22, p = .026$ , which is significant which is assumed unequal variances.

The between-subject effects are illustrated in Table 4-6. The Type III Sums of Squares was also reported to show the sum, overall observations, of the differences squared of each observation of the dependent variable between the independent variables from the overall mean matrices (Cohen, 2008, p. 54).

### **Results for Null Hypothesis Three**

#### **Low, Middle, and High Groups**

The null hypothesis three states that there was no change in the dimensions of motivation to engage in a writing activity with individual students who scored in the

Table 4-6

*Between Subject Results for Gender*

Source	Dependent variable	Type III sum of squares	<i>df</i>	Mean square	<i>F</i>	Sig.	Partial eta squared
Gender	Challenge	< 0.0	1	< 0.0	.000	.99	.00
	Choice	.22	1	.22	.35	.56	.00
	Enjoyment	.38	1	.38	.68	.41	.01
	Interest	.89	1	.89	1.44	.23	.02

upper and lower groups on the pretest and who learned computer programming in a collaborative learning environment using a sequential concept map as a graphical organizer as compared to those who did not.

#### **Low Treatment Group Results on Challenge**

Table 4-7 illustrates that five students were represented in the low group on the pretest who received the treatment. Two of these five students demonstrated movement from the low group on the pretest to the middle or high group on the posttest after scoring in the middle or high group on the science test. The movement of these two students represents 40% of the population of the low group, which received the treatment on the dimension of challenge.

#### **Low Control Group Results on Challenge**

Table 4-8 illustrates that 10 students were represented in the low group on the pretest who did not receive the treatment. Two of these 10 students demonstrated movement from the low group on the pretest to the middle or high group on the posttest

Table 4-7

*Movement of Students in the Pretest Low-Treatment Group on the Dimension of Challenge*

Student	Pretest group	Science group	Posttest group	Meets movement criteria
62	Low	Middle	Low	
5	Low	Low	Low	
6	Low	Mid	Middle	X
73	Low	Low	Middle	
72	Low	High	High	X

Table 4-8

*Movement of Students in the Pretest Low-Control Group on the Dimension of Challenge*

Student	Pretest group	Science group	Posttest group	Movement
92	Low	Low	Low	
39	Low	Low	Low	
53	Low	Middle	Low	
96	Low	Low	Low	
51	Low	Low	Low	
44	Low	Low	Low	
80	Low	Low	Low	
78	Low	Middle	Middle	X
43	Low	Low	Middle	
89	Low	Middle	Middle	X

after scoring in the middle or high group on the science test. The movement of these two students represents 20% of the population of the low group that did not receive the treatment on the dimension of challenge.

### High Treatment Group Results on Challenge

Table 4-9 illustrates that 14 students were represented in the high group on the pretest who received the treatment. Four of these 14 students demonstrated movement from the high group on the pretest to the middle or low group on the posttest after scoring in the middle or low group on the science test. The movement of these four students represents 29% of the population of the high group that received the treatment on the dimension of challenge.

### High Control Group Results on Challenge

Table 4-10 illustrates that nine students were represented in the high group on the pretest who did not receive the treatment. Four of these nine students demonstrated

Table 4-9

#### *Movement of Students in the Pretest High-Treatment Group on the Dimension of Challenge*

Student	Pretest group	Science group	Posttest group	Meets movement criteria
70	High	Low	Low	X
66	High	High	Middle	
2	High	High	Middle	
7	High	Middle	Middle	X
59	High	Middle	Middle	X
64	High	Middle	Middle	X
26	High	Middle	High	
1	High	High	High	
60	High	High	High	
9	High	High	High	
61	High	High	High	
65	High	High	High	
12	High	High	High	
19	High	High	High	

Table 4-10

*Movement of Students in the Pretest High-Control Group on the Dimension of Challenge*

Student	Pretest group	Science group	Posttest group	Meets movement criteria
91	High	Middle	Low	X
93	High	Middle	Middle	X
83	High	High	Middle	
81	High	Middle	Middle	X
88	High	Middle	Middle	X
33	High	Middle	High	
30	High	High	High	
49	High	High	High	
50	High	High	High	

movement from the high group on the pretest to the middle or low group on the posttest after scoring in the middle or high group on the science test. The movement of these four students represents 44% of the population of the low group who did not receive the treatment on the dimension of challenge.

On the dimension of challenge, Table 4-11 illustrates the low group who received the treatment moved 40%; whereas, the low group that did not receive the treatment moved 20%. This represents a 20% gain for the treatment group over the control group indicating that the treatment may benefit certain individuals.

On the dimension of challenge, Table 4-11 illustrates the high group who received the treatment moved 29%; whereas, the high group that did not receive the treatment moved 44%. This represents a 15% movement of the treatment group over the control group indicating that the treatment possibly did not lower the individuals in the high group who received the treatment.

Table 4-11

*Low and High Treatment and Control Group Movement on the Four Dimensions*

Dimension	Group	Treatment/control	Percentage of group that moved	Percentage difference in movement
Challenge	Low	Treatment	40	20
		Control	20	
	High	Treatment	29	15
		Control	44	
Choice	Low	Treatment	40	+20
		Control	20	
	High	Treatment	57	-44
		Control	13	
Enjoyment	Low	Treatment	66	66
		Control	0	
	High	Treatment	21	15
		Control	36	
Interest	Low	Treatment	50	12
		Control	38	
	High	Treatment	19	28
		Control	47	

*Note.* To determine percentage difference in movement for low and high groups the following formulas were used:

- Low group percentage difference = treatment % – control %
- High group percentage difference = control % – treatment %

For the other three dimensions (choice, enjoyment, and interest), Table 4-11 was developed using same technique that was used to develop percentages of movements for the dimension of challenge. These percentages of movements for choice, enjoyment, and interest were developed using 12 similar tables found in Appendix F (see Tables F1 -



F12). These tables, along with the four above were used in the development of Table 4-11.

### **Summary**

The purpose of this chapter was to report the findings on the following three hypotheses.

H1o: There was no change in the dimensions of motivation to engage in a writing activity between students who learned computer programming in a collaborative learning environment using a sequential concept map as a graphical organizer and those who did not.

H2o: There was no change in the dimensions of motivation to engage in a writing activity within male and female students who learned computer programming in a collaborative learning environment and using a sequential concept map and those who did not.

H3o: There was no change in the dimensions of motivation to engage in a writing activity with individual students who scored in the upper and lower groups on the pretest and who learned computer programming in a collaborative learning environment using a sequential concept map as a graphical organizer as compared to those who did not.

The null hypothesis one was investigated by utilizing the mean difference of the treatment and control group followed up with a MGLM. The null hypothesis two was investigated by utilizing the mean difference of the treatment and control group followed up with a MGLM. The null hypothesis three was investigated by using Gentry and

Gables cut-off scores to assign individual students into low, middle, and high groups on each dimension. The students were then tracked from the pretest, science test, and the posttest and reported by percentage of individual movement for those students who scored in the low and high groups on the pretest.

## **CHAPTER 5**

### **INTERPRETATIONS, CONCLUSIONS, AND RECOMMENDATIONS**

#### **Introduction**

The purpose of this study was to investigate the change in the dimensions of motivation which are: challenge, choice, enjoyment, and interest of fifth-grade students to engage in an expository writing activity after being taught to develop computer programs with the same teaching strategies used in the writing activity. To investigate this study, the following null hypotheses were formulated.

H1o: There was no significant change in the dimensions of motivation to engage in a writing activity between students who learned computer programming in a collaborative learning environment using a sequential concept map as a graphical organizer and those who did not.

H2o: There was no significant change in the dimensions of motivation to engage in a writing activity within male and female students who learned computer programming in a collaborative learning environment and using a sequential concept map and those who did not.

H3o: There was no change in the dimensions of motivation to engage in a writing activity with individual students who scored in the upper and lower groups on the pretest and who learned computer programming in a collaborative learning environment using a sequential concept map as a graphical organizer as compared to those who did not.

A MGLM was used to investigate the null hypothesis one and null hypothesis

two. The null hypothesis three was investigated by using Gentry and Gables cut-off scores to assigning the students into low, middle, and high groups on each dimension. The students, in the low and high groups were then tracked through the pretest, science test, and the posttest and reported.

### **Null Hypothesis One and Two**

The null hypothesis H1o states that there was no significant change in the dimensions of motivation to engage in a writing activity between students who learned computer programming in a collaborative learning environment using a sequential concept map as a graphical organizer and those who did not. The null hypothesis one was evaluated by utilizing a MGLM. There was no statistical significance between treatment and control groups on challenge, choice, enjoyment, and interest.

The null hypothesis H2o states that there was no significant change in the dimensions of motivation to engage in a writing activity within male and female students who learned computer programming in a collaborative learning environment and using a sequential concept map and those who did not. The null hypothesis two was investigated by utilizing a MGLM. There was no statistical significance between male and female groups on challenge, choice, enjoyment, and interest. Before hypothesis H1o and H2o were tested, *t* tests were conducted which detected certain phenomena in this study.

From the pretest to the posttest, a reduction on the four dimensions of motivation occurred in both the control group and the treatment group. This reduction in scores did not influence the difference between the control group and the treatment group. Figure 5-1 illustrates that both the control and treatment group scores were significantly lower on

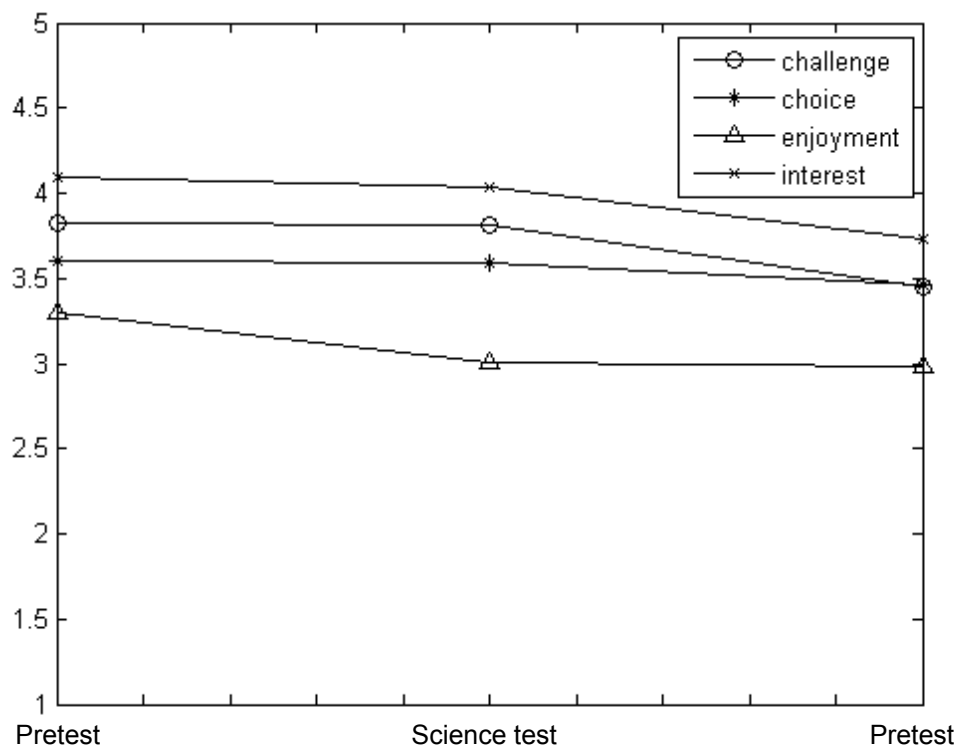

*Figure 5-1.* Means for both control and treatment groups on the pretest, science test, and the posttest.

the posttest than on the pretest after the science test on the four dimensions.

There are three possible explanations developed by the research to explain the drop in scores from the pretest to the posttest. First, the writing activity associated with the pretest included students making “chocolate truffles” which are crushed Oreo cookies, mixed into an icing, then placed on a stick, and dipped in chocolate. The motivation of making and eating “chocolate truffles” is likely to increase the four dimensions of motivation in the students more than the posttest activity of writing about a normal day’s schedule. The literature shows that even when students write about chocolate their motivation increases (Turner & Paris, 1995, p. 665). This explanation could have affected the students on the four dimensions of motivation.

Second, hands-on activities are especially popular in elementary education. Hands-on activities influence motivation (Gerstner & Bogner, 2009, p. 850). The pretest activity and the science activity for both groups involved hands-on activities. The pretest and the posttest activities both involved expository writing; however, the posttest activity was not a hands-on activity. The lack of a hands-on component in the posttest activity could have affected the students negatively on the four dimensions.

Third, the posttest was administered prior to spring break. During this time students were eager for their vacation. Taking the posttest so close to spring break may have affected the students on the four dimensions of motivation.

### **Null Hypotheses Three**

The null hypothesis three states that there was no change in the dimensions of motivation to engage in a writing activity with individual students who scored in the upper and lower groups on the pretest and who learned computer programming in a collaborative learning environment using a sequential concept map as a graphical organizer as compared to those who did not.

### **Movement of All Four Dimensions**

Table 4-13 illustrated that a greater percentage of individual students in the treatment group who scored low on the pretest were positively impacted on all four dimensions of motivation than students who scored low in the control group on the pretest. Conversely, a greater percentage of individual students in the treatment group who scored high on the pretest were positively motivated on three of the four dimensions

of motivation than students who scored high in the control group on the pretest. The students who scored in the high group on the pretest were more positively impacted on the dimensions of challenge, enjoyment, and interest and were negatively impacted on the dimension of choice. To make the statement that these impacts are statistically significant is not possible because of the *N* size available in each of the low and high groups. However, it appears from the data that the treatment positively impacted some individuals who scored low on the pretest. This treatment may be beneficial as a remedial activity for low-motivated students in the context area of writing.

### **Conclusions and Recommendations**

Based on the null hypothesis one and two, it is evident that the treatment had no significant impact. However, when investigating hypothesis three it appears that there are some positive impacts on individual students who scored low on the pretest. Although it could be argued that the sample size for this hypothesis is too small to show any statistical significance, this impact should be investigated further.

This study did not show statistical significance; however, there were several observations made during this study that may improve a similar study and render different results. These observations include: increasing the length of the study, increasing the number of lessons delivered, and equating writing activities.

The timeline for this study was approximately one month during the spring school year. This study investigated the four dimensions of motivation, which can be categorized in the affective domain. Because the affective domain typically takes longer to change in

most individuals a longer timeline for future studies would be recommended. It is recommended a similar study be conducted over an entire school year.

Increasing the length of the study would obviously require additional interventions (lessons) both in writing and in computer programming. As a recommendation for further studies the number of lessons should increase to a minimum of four writing and programming lessons to a maximum of six lessons for each subject area over the course of a school year.

In this study, there were two expository writing lessons that were taught. The prewriting activity was a hands-on activity that involved making an edible treat. The post-writing activity involved writing about a normal school day and what happens if the normal school day was interrupted by a pep rally. The postactivity was not equated with the prewriting activity. Because of this inequality, it may be possible that the students' overall motivation was affected by other factors than the treatment. Therefore, it is recommended for future studies that the writing activities should be delivered as equal as possible. With these recommended changes, a similar study would be recommended to investigate both null hypotheses one and two.

### **Summary**

The results of the null hypothesis one and null hypothesis two suggest that the teaching of computer programming was not effective with the intention of motivating the masses of fifth-grade students to write. However, the literature shows that computer programming activities are in their infancy and gaining popularity in the elementary



schools. The teaching of computer programming in the elementary schools should or should not be taught based on its own merit.

According to the results of null hypothesis three, there appears to be support that teaching computer programming to fifth-grade students may help some individual students. These students, who may benefit from this treatment, were identified as scoring in the low group on the pretest then scoring in the middle to high group, on the posttest after having scored in the middle or high group on the science test. The treatment of teaching programming to low motivated students in the area of writing may have remedial merit for select individuals.

## REFERENCES

- Ballinger, K. A. (2009). *Academic writing motivation: A qualitative study of adolescents' perspectives* (Doctoral dissertation). Available from ProQuest Dissertations and Theses database. (UMI No. 3373670)
- Beyer, S., Rynes, K., Perrault, J., Hay, K., & Haller, S. (2003). Gender differences in computer science students. *ACM SIGCSE Bulletin*, 35(1), 49-53.
- Brace, N., Kemp, R., & Snelgar, R. (2012). *SPSS for psychologists* (5<sup>th</sup> ed.). New York, NY: Macmillan.
- Byrne, P., & Lyons, G. (2001). The effect of student attributes on success in programming. *ACM SIGCSE Bulletin*, 33(3), 49-52.
- Carter, L. (2006, March). *Why students with an apparent aptitude for computer science don't choose to major in computer science*. Paper presented at the 37<sup>th</sup> SIGCSE Technical Symposium on Computer Science Education, New York, NY.
- Chularut, P., & DeBacker, T. K. (2004). The influence of concept mapping on achievement, self-regulation, and self-efficacy in student of English as a second language. *Contemporary Educational Psychology*, 29, 248-263.
- Cockburn, A., & Williams, L. (2001). *The cost and benefits of pair programming*. Retrieved from [http://reference.kfupm.edu.sa/content/c/o/the\\_cost\\_and\\_benefits\\_of\\_pair\\_programmi\\_114178.pdf](http://reference.kfupm.edu.sa/content/c/o/the_cost_and_benefits_of_pair_programmi_114178.pdf)
- Cohen, B. H. (2008). *Explaining psychological statistics* (3<sup>rd</sup> ed.). Hoboken, NJ: Wiley.
- Cook, P. J., Green, R. M., Meyer, T. S., & Saey, L. A. (2001). *Increasing motivation to write by enhancing self-perception, utilizing collaboration, modeling and relevance* (Master's thesis). Available from Education Resources Information Center. (ERIC Doc. No. ED435 524)
- Deci, E. L., & Chandler, C. L. (1986). The importance of motivation for the future of the field. *Journal of Learning Disabilities*, 19, 587-594.
- Dimitrov, D. M., & Rumrill, P. D. (2003). Pretest-posttest designs and measurement of change. *A Journal of Prevention, Assessment and Rehabilitation*, 20(2), 159-165.
- Education Place. (2014). [Classroom resources.] <http://www.eduplace.com/>

- Elliot, A. J. (1999). Approach and avoidance motivation and achievement goals. *Educational Psychologist, 34*(3), 169-189.
- Forte, A., & Guzdial, M. (2005). *Motivation and non-majors in computer science: Identifying discrete audiences for introductory courses*. Retrieved from <http://citeseerx.ist.psu.edu/viewdoc/download?doi=10.1.1.167.6010&rep=rep1&type=pdf>
- Frymier, A. B. (1994). The use of affinity-seeking in producing liking and learning in the classroom. *Journal of Applied Communication Research, 22*, 87-105.
- Garcia, J. N., & De Caso, A. M. (2004). Effects of a motivational intervention for improving the writing of children with learning disabilities. *Learning Disability Quarterly, 27*(3), 141-159.
- Garrett, L., & Moltzen, R. (2011). Writing because I want to, not because I have to: gifted writers' perspectives on the factors that "matter" in developing expertise. *Research Commons, 10*(1), 165-180.
- Gentry, M., & Gable, R. K. (2001). *My class activities*. Mansfield Center, CT: Creative Learning Press.
- Gerstner, S., & Bogner, F. X. (2009). Cognitive achievement and motivation in hands-on and teacher-centred science classes: Does an additional hands-on consolidation phase (concept mapping) optimize cognitive learning at work stations? *International Journal of Science Education, 32*, 849-870.
- Goguen, J. A., & Burstall, R. M. (1992). Institutions: Abstract model theory for specification and programming. *Journal of the ACM, 39*, 95-146.
- Hadley, K. M., & Dorward, J. (2011). The relationship among elementary teachers' mathematics anxiety, mathematics instructional practices, and student mathematics achievement. *Journal of Curriculum & Instruction, 5*(2), 27-44.
- Harris, K. R., Graham, S., & Mason, L. H. (2006). Improving the writing: Knowledge, and motivation of struggling young writers: Effect of self-regulated strategy development with and without peer support. *American Educational Research Journal, 43*, 295-340.
- Hsia, P., & Petry, P. E. (1980). A framework for discipline in programming. *IEEE Transactions on Software Engineering, 6*, 226-232.
- Hunt, W. (2011). *Motivation to learn: An overview*. Retrieved from <http://www.edpsycinteractive.org/topics/motivation/motivate.html>

- Hunsaker, S. L., Nielsen, A., & Bartlett, B. (2010). Correlates of teacher practices influencing student outcomes in reading instruction for advanced readers. *Gifted Child Quarterly*, 4, 273-282.
- Hyerle, D., & Yeager, C. (2007). *A language for learning*. Cary, NC: Thinking Maps.
- IBM. (2012). *GLM multivariate analysis*. Retrieved from [http://pic.dhe.ibm.com/infocenter/spssstat/v21r0m0/index.jsp?topic=%2Fcom.ibm.spss.statistics.help%2Ffidh\\_glm\\_multivariate.htm](http://pic.dhe.ibm.com/infocenter/spssstat/v21r0m0/index.jsp?topic=%2Fcom.ibm.spss.statistics.help%2Ffidh_glm_multivariate.htm)
- International Technology and Engineering Education Association. (2007). *Standards for technology literacy*. Retrieved from <http://www.iteaconnect.org/TAA/PDFs/xstnd.pdf>
- Isen, A. M., & Reeve, J. (2005). The influence of positive affect on intrinsic and extrinsic motivation: Facilitating enjoyment of play, responsible work behavior, and self-control. *Motivation & Emotion*, 29, 297-324.
- Jankauskas, J. B. (2003). *Exploring goal-setting instruction with grade 8 writing students* (Doctoral dissertation). Available from ProQuest Dissertations and Theses database. (UMI No. 3297171)
- Jenkins, T. (2001). The motivation of students of programming. *ACM SIGCSE Bulletin*, 33(3), 53-56.
- Jiau, H., Chen, J. C., & Ssu, K. F. (2009). Enhancing self-motivation in learning programming using game-based simulation and metrics. *IEEE Transactions on Education*, 52(4), 555-562.
- Keil, M. G. (2001). *One student's perception of the academic writing experience and its influence on motivation to write: A longitudinal case study* (Doctoral dissertation). Available from ProQuest Dissertations and Theses database. (UMI No. 3029949)
- King, A. (1993). From sage on the stage to guide on the side. *College Teaching*, 41(1), 30-35.
- Kohnke, J. L. (2006). *Supporting and sustaining student motivation within the context of a writing workshop in a fourth grade classroom* (Doctoral dissertation). Available from ProQuest Dissertations and Theses database. (UMI No. 3207586)
- Koskinen, P. S., Palmer, B. M., & Codling, R. M. (1994). In their own words: What elementary students have to say about motivation to read. *National Reading Research Center*, 48(2), 176-178.

- Kumar, D. (2014). Digital playgrounds for early computing education [Supplemental material]. *Inroads*, 5(1), 20-21.
- Lakhani, K., & Wolf, R. G. (2003). *Why hackers do what they do: Understanding motivation and effort in free/open source software projects*. Retrieved from <http://ssrn.com/abstract=443040> or <http://dx.doi.org/10.2139/ssrn.443040>
- Lawson, H. A. (2004). The logic of collaboration in education and the human services. *Journal of Interprofessional Care*, 18(3), 225-237.
- Maloney, J. H., Peppler, K., Kafai, Y., Resnick, M., & Rusk, N. (2008). Programming by choice: Urban youth learning programming with scratch. *ACM SIGCSE Bulletin*, 40(1), 367-371.
- Mason, L. H., Meadan, H., Hedin, L. R., & Cramer, A. M. (2012). Avoiding the struggle: Instruction that supports students' motivation in reading and writing about content material. *Reading & Writing Quarterly*, 28, 70-96.
- Meece, J. L., & Miller, S. D. (1999). Changes in elementary school children's achievement goals for reading and writing: Results of a longitudinal and intervention study. *Scientific Studies of Reading*, 3, 207-229.
- Merisuo-Storm, T. (2006). Girls and boys like to read and write different text. *Scandinavian Journal of Educational Research*, 50(2), 111-125.
- Nastasi, B. K., Clements, D. H., & Battista, M. T. (1990). Social-cognitive interactions, motivation, cognitive growth in logo programming and CAI problem-solving environments. *Journal of Educational Psychology*, 82(1), 150-158.
- Nesbit, J. C., & Adesope, O. O. (2006). Learning with concept and knowledge maps: A meta-analysis. *Review of Educational Research*, 76, 413-448.
- Northouse, P. G. (2010). *Leadership: Theory and practice* (5<sup>th</sup> ed.). Los Angeles, CA: Sage.
- Norton, S. J., McRobbie, C. J., & Ginns, I. S. (2007). Problem solving in a Middle school robotics design classroom. *Research in Science Education*, 37, 261-277.
- Nunnally, J. (1978). *Psychometric theory*. New York, NY: McGraw-Hill.
- Potter, E. F., McCormick, C. B., & Busching, B. A. (1994, April). *Motivation in the writing classroom: Contributions of goal theory*. Paper presented at the American Educational Research Association Meeting, New Orleans, LA.

- Robinson, D. H., & Kiewra, K. A. (1995). Visual argument: Graphic organizers are superior to outlines in improving learning from text. *Journal of Educational Psychology, 87*(3), 455-467.
- Schiefele, U. (1991). Interest, learning, and motivation. *Educational Psychologist, 26*, 299-323.
- Schraw, G., Flowerday, T., & Lehman, S. (2001). Increasing situational interest in the classroom. *Educational Psychology Review, 13*(3), 211-224.
- Shneiderman, B., Mayer, R., McKay, D., & Heller, P. (1977). Experimental investigations of the utility of detailed flowcharts in programming. *Communications of the ACM, 20*, 373-381.
- Simon, M. K., & Goes, J. (2013). *Scope, limitations, and delimitations*. Retrieved from <http://dissertationrecipes.com/wp-content/uploads/2011/04/limitationscope-delimitation1.pdf>
- Stanford University. (2013). *Information about expository writing*. Retrieved from <http://www.stanford.edu/~arnetha/expowrite/info.html>
- Sternberg, R. J., & Lubart, T. I. (1998). *Handbook of creativity*. New York, NY: Cambridge University Press.
- Sturm, J. M., & Rankin-Erickson, J. L. (2002). Effects of hand-drawn and computer-generated concept mapping on the expository writing of middle school students with learning disabilities. *Learning Disabilities: Research & Practice, 17*(2), 124-139.
- Turner, J., & Paris, S. G. (1995). How literacy tasks influence children's motivation for literacy. *The Reading Teacher, 48*, 662-673.
- U.S. Department of Education, Institute of Education Sciences, National Center for Education Statistics, National Assessment of Educational Progress. (2012a). *The nations report card: Writing 2011—National assessment of educational progress at grades 8 and 12* (NCES Publication No. 2012-470). Retrieved from <http://nces.ed.gov/nationsreportcard/pdf/main2011/2012470.pdf>
- U.S. Department of Education, Institute of Education Sciences, National Center for Education Statistics. (2012b). *Higher education: Gaps in access and persistence study* (NCES Publication No. 2012-046). Retrieved from <http://nces.ed.gov/pubs/2012/2012046.pdf>

- Utah State Board of Education. (2002). *Utah elementary science core curriculum: Fifth grade*. Retrieved from <http://www.uen.org/core/core.do?courseNum=3050>
- Webb, N. M., Ender, P., & Lewis, S. (1986). Problem-solving strategies and group processes in small groups learning computer programming. *American Educational Research Journal*, 23, 243-261.
- Weiderman, N. H., & Rawson, B. M. (1975). Flowcharting loops without cycles. *ACM SIGPLAN Notices*, 10(4), 37-46.
- White House. (Producer). (2013). *President Obama on computer programming in high school in a Google+ Hangout* [Video file]. Available from <http://www.youtube.com/watch?v=PCLfyIbIr5Q>
- Wilder, G., Mackie, D., & Cooper, J. (1985). Gender and computers: Two surveys of computer-related attitudes. *Sex Roles*, 13(3-4), 215-228.
- Williams, L., Wiebe, E., Yang, K., Ferzli, M., & Miller, C. (2002). *In support of pair programming in the introductory computer science course*. Retrieved from [http://collaboration.csc.ncsu.edu/laurie/Papers/PP%20in%20Introductory\\_CSED.pdf](http://collaboration.csc.ncsu.edu/laurie/Papers/PP%20in%20Introductory_CSED.pdf)
- Williams, S. E. (2009). *An experimental comparison of middle school students motivation and preference toward text and graphic-based programming* (unpublished master's thesis). Utah State University, Logan, UT.
- Wilson, B. C., & Shrock, S. (2001). Contributing to success in an introductory computer science course: A study of twelve factors. *ACM SIGCSE Bulletin*, 33(1), 184-188.
- Yoder, B. L. (2011). *Engineering by the numbers*. Retrieved from <http://www.asee.org/papers-and-publications/publications/college-profiles/2011-profile-engineering-statistics.pdf>

**APPENDICES**



Appendix A  
IRB Signature Form



**INFORMED CONSENT**  
AN INVESTIGATION OF THE CHANGE IN MOTIVATION OF FIFTH GRADE STUDENTS IN  
WRITING AFTER BEING TAUGHT COMPUTER  
PROGRAMMING USING SIMILAR TEACHING STRATEGIES

**Introduction/ Purpose** Dr. Gary Stewardson and Raymond Boyles in the Department of Agricultural Systems Technology and Education (ASTE) at Utah State University are conducting a research study to find out more about the relationship of student motivation in writing when exposed to computer programming using similar instructional strategies. There will be approximately 60 participants at this site. There will be approximately 120 total participants in this research. Raymond Boyles, a graduate student, will conduct the study as part of his doctoral program.

**Procedures**

Your student is going to have an opportunity to be taught several lessons from the Utah State Core curriculum using proven instructional strategies. This study will begin with a writing activity taught by their classroom teacher using collaborative learning groups and graphical organizers. This writing activity will take approximately one week. At the end of this activity the student will be given a pencil/paper survey consisting of 31 questions that will measure the student's motivation towards their classroom activity.

The students will then be taught the Utah Science Core Curriculum in the area of electricity. The application of these electrical concepts will be applied through a programming /controls activity using a LEGO controller. This activity will take approximately four weeks. . At the end of this activity the student will be given a pencil/paper survey consisting of 31 questions that will again measure the student's motivation towards their classroom activity.

Next, the writing activity that was initially performed will be repeated along with the survey to measure motivation. All data gathered for the purpose of this study will be coded and kept confidential. In summary your student will complete two writing activities and one science activity which are part of the Utah Core Curriculum and complete a survey that will measure their motivation to each classroom activity three times.

**Risks** There is a small risk of loss of confidentiality of data however, the researchers will follow all of the Institutional Review Board guidelines and procedures to reduce this risk to ensure that all data is kept confidential. There is also a small risk when working with electricity. Curriculum, with safety lessons, has been developed and field tested to ensure a safe environment. In addition, the classroom teacher and researchers will be in direct supervision at all times to monitor and ensure a safe environment.

**Benefits** If the researcher hypothesis is correct your student and others may be more motivated to write. In addition, your student will receive an introductory experience in computer programming, a 21<sup>st</sup> century skill.



Page 2 of 3

### INFORMED CONSENT

#### AN INVESTIGATION OF THE CHANGE IN MOTIVATION OF FIFTH GRADE STUDENTS IN WRITING AFTER BEING TAUGHT COMPUTER PROGRAMMING USING SIMILAR TEACHING STRATEGIES

**Explanation & offer to answer questions** Raymond Boyles has explained this research study to your student and answered their questions. If you have questions or research-related problems, you may reach Raymond Boyles at (435) 938-8321 or Gary Stewardson at (435) 797-1802.

**Voluntary nature of participation and right to withdraw without consequence** Participation in research is entirely voluntary. You may refuse to participate or withdraw at any time without consequence or loss of benefits. If you have other questions or research-related problems, you may reach Raymond Boyles at (435)-938-8321 or Gary Stewardson at (435) 797-1802.

**Confidentiality** Research records will be kept confidential, consistent with federal and state regulations. Only the investigators will have access to the data which will be kept in a locked file cabinet or on a password protected computer in a locked room. To protect your privacy, personal, identifiable information will be removed from study documents and replaced with a study identifier. Identifying information will be stored separately from data and will be kept secure. At the end of this study, the data will be destroyed.

**IRB Approval Statement** The Institutional Review Board for the protection of human participants at Utah State University has approved this research study. If you have any questions or concerns about your rights or a research-related injury and would like to contact someone other than the research team, you may contact the IRB Administrator at (435) 797-0567 or email [irb@usu.edu](mailto:irb@usu.edu) to obtain information or to offer input.

**Copy of consent** You have been given two copies of this Informed Consent. Please sign both copies and keep one copy for your files and have your student return the other copy.

**Investigator Statement** "I certify that the research study has been explained to the individual, by me or my research staff, and that the individual understands the nature and purpose, the possible risks and benefits associated with taking part in this research study. Any questions that have been raised have been answered."

**Utah State University**  
 Department of Agricultural Systems  
 Technology and Education  
 6000 Old Main Hill  
 Logan UT 84322-6000  
 Telephone: (435) 797-1802



**INFORMED CONSENT**

AN INVESTIGATION OF THE CHANGE IN MOTIVATION OF FIFTH GRADE STUDENTS IN  
 WRITING AFTER BEING TAUGHT COMPUTER  
 PROGRAMMING USING SIMILAR TEACHING STRATEGIES

**Signature of Researcher(s)**

  
 \_\_\_\_\_  
 Gary Stewardson  
 Principal Investigator  
 (435) 797-0567  
 Gary.Stewardson@usu.edu

  
 \_\_\_\_\_  
 Raymond Boyles  
 Student Researcher (or Co-PI)  
 (435)-938-8321  
 Raymond.Boyles@aggiemail.usu.edu

**Signature of Parent/Guardian or Legally Authorized Representative.** By signing below, I agree to participate.

\_\_\_\_\_  
 Parent/Guardian or Legally Authorized  
 Representative signature

\_\_\_\_\_  
 Date

\_\_\_\_\_  
 Relationship

\_\_\_\_\_  
 Translator if Applicable

\_\_\_\_\_  
 Date

**Child/Youth Assent:** I understand that my parent(s) or guardian(s) are aware of this research study and that they have given permission for me to participate. I understand that it is up to me to participate even if they say yes. If I do not want to be in this study, I do not have to and no one will be upset if I don't want to participate or if I change my mind later and want to stop. I can ask any questions that I have about this study now or later. By signing below, I agree to participate.

\_\_\_\_\_  
 Name/Signature

\_\_\_\_\_  
 Date

Appendix B

My Class Activities Survey Instrument Answer Sheet

Student Survey About...

# My Class Activities

Marcia Gentry Ph.D. and Robert K. Gable Ed.D.



Student ID		A	B	C	D
0	0	0	0	0	0
1	1	1	1	1	1
2	2	2	2	2	2
3	3	3	3	3	3
4	4	4	4	4	4
5	5	5	5	5	5
6	6	6	6	6	6
7	7	7	7	7	7
8	8	8	8	8	8
9	9	9	9	9	9

- We would like to know how you feel about your class activities. Read each sentence and indicate how often this happens for you in your class by coloring in the doughnut. There are no right or wrong answers. Your answers will be kept secret. Remember to color in a doughnut for each sentence.

Name/ID \_\_\_\_\_ (Optional)

Subject/Class \_\_\_\_\_ Teacher \_\_\_\_\_

Grade

3  4  5  6  7  8

I am a . . .

Female  Male



In the example below, the person indicated that his/her class is often enjoyable.

	Never	Seldom	Some-times	Often	Always
Example: My class is enjoyable.	<input type="radio"/>	<input type="radio"/>	<input type="radio"/>	<input checked="" type="radio"/>	<input type="radio"/>

	Never	Seldom	Some-times	Often	Always
1. What I do in my class fits my interests.	<input type="radio"/>	<input type="radio"/>	<input type="radio"/>	<input type="radio"/>	<input type="radio"/>
2. I have an opportunity to work on things in my class that interest me.	<input type="radio"/>	<input type="radio"/>	<input type="radio"/>	<input type="radio"/>	<input type="radio"/>
3. What I do in my class gives me interesting and new ideas.	<input type="radio"/>	<input type="radio"/>	<input type="radio"/>	<input type="radio"/>	<input type="radio"/>
4. I study interesting topics in my class.	<input type="radio"/>	<input type="radio"/>	<input type="radio"/>	<input type="radio"/>	<input type="radio"/>
5. The teacher involves me in interesting learning activities.	<input type="radio"/>	<input type="radio"/>	<input type="radio"/>	<input type="radio"/>	<input type="radio"/>
6. What I learn in my class is interesting to me.	<input type="radio"/>	<input type="radio"/>	<input type="radio"/>	<input type="radio"/>	<input type="radio"/>
7. What I do in my class is interesting.	<input type="radio"/>	<input type="radio"/>	<input type="radio"/>	<input type="radio"/>	<input type="radio"/>
8. My class has helped me explore my interests.	<input type="radio"/>	<input type="radio"/>	<input type="radio"/>	<input type="radio"/>	<input type="radio"/>
9. The activities I do in my class are challenging.	<input type="radio"/>	<input type="radio"/>	<input type="radio"/>	<input type="radio"/>	<input type="radio"/>
10. I have to think to solve problems in my class.	<input type="radio"/>	<input type="radio"/>	<input type="radio"/>	<input type="radio"/>	<input type="radio"/>

Please continue on the back

Side 2

	Never	Seldom	Some- times	Often	Always
11. I use challenging materials and books in my class.	<input type="radio"/>	<input type="radio"/>	<input type="radio"/>	<input type="radio"/>	<input type="radio"/>
12. I challenge myself by trying new things.	<input type="radio"/>	<input type="radio"/>	<input type="radio"/>	<input type="radio"/>	<input type="radio"/>
13. My work can make a difference.	<input type="radio"/>	<input type="radio"/>	<input type="radio"/>	<input type="radio"/>	<input type="radio"/>
14. I find the work in this class demanding.	<input type="radio"/>	<input type="radio"/>	<input type="radio"/>	<input type="radio"/>	<input type="radio"/>
15. I am challenged to do my best in class.	<input type="radio"/>	<input type="radio"/>	<input type="radio"/>	<input type="radio"/>	<input type="radio"/>
16. What we do in class fits my abilities.	<input type="radio"/>	<input type="radio"/>	<input type="radio"/>	<input type="radio"/>	<input type="radio"/>
17. This class is difficult.	<input type="radio"/>	<input type="radio"/>	<input type="radio"/>	<input type="radio"/>	<input type="radio"/>
18. I can choose to work in a group.	<input type="radio"/>	<input type="radio"/>	<input type="radio"/>	<input type="radio"/>	<input type="radio"/>
19. I can choose to work alone.	<input type="radio"/>	<input type="radio"/>	<input type="radio"/>	<input type="radio"/>	<input type="radio"/>
20. When we work together, I can choose my partners.	<input type="radio"/>	<input type="radio"/>	<input type="radio"/>	<input type="radio"/>	<input type="radio"/>
21. I can choose my own projects.	<input type="radio"/>	<input type="radio"/>	<input type="radio"/>	<input type="radio"/>	<input type="radio"/>
22. When there are many jobs, I can choose the ones that suit me.	<input type="radio"/>	<input type="radio"/>	<input type="radio"/>	<input type="radio"/>	<input type="radio"/>
23. I can choose materials to work with in the class.	<input type="radio"/>	<input type="radio"/>	<input type="radio"/>	<input type="radio"/>	<input type="radio"/>
24. I can choose an audience for my product.	<input type="radio"/>	<input type="radio"/>	<input type="radio"/>	<input type="radio"/>	<input type="radio"/>
25. I look forward to my class.	<input type="radio"/>	<input type="radio"/>	<input type="radio"/>	<input type="radio"/>	<input type="radio"/>
26. I have fun in my class.	<input type="radio"/>	<input type="radio"/>	<input type="radio"/>	<input type="radio"/>	<input type="radio"/>
27. The teacher makes learning fun.	<input type="radio"/>	<input type="radio"/>	<input type="radio"/>	<input type="radio"/>	<input type="radio"/>
28. I like what I do in my class.	<input type="radio"/>	<input type="radio"/>	<input type="radio"/>	<input type="radio"/>	<input type="radio"/>
29. I like working in my class.	<input type="radio"/>	<input type="radio"/>	<input type="radio"/>	<input type="radio"/>	<input type="radio"/>
30. The activities I do in my class are enjoyable.	<input type="radio"/>	<input type="radio"/>	<input type="radio"/>	<input type="radio"/>	<input type="radio"/>
31. I like the projects I work on in my class.	<input type="radio"/>	<input type="radio"/>	<input type="radio"/>	<input type="radio"/>	<input type="radio"/>

00095

Appendix C  
Core Curriculum



## Scope and Sequence

### Unit: Electrical Controls and Programming

**Lesson 1:** Light a light-bulb

**Lesson 2:** Follow safety practices

**Lesson 3:** Test for Conductivity

**Lesson 4:** Electrical properties and components

**Lesson 5:** Wire a simple circuit

**Lesson 6:** Wire a series circuit

**Lesson 7:** Wire a parallel circuit

**Lesson 8:** Wire a mechanical relay

**Lesson 9:** Write a program to turn on individual outputs

**Lesson 10:** Write a program to control a traffic light

**Lesson 11:** Write a program to control a traffic light based on the input of a switch

**Lesson 12:** Write a program to control a Ping-Pong ball feeder

**Lesson 13:** Write a program to control a Ping-Pong ball feeder based on inputs.

**NOTE:** The above curriculum unit meets the following standard, objective, indicators, and science language of the Utah Fifth Grade Science Core Curriculum:

**STANDARD IV:** Students will understand features of static and current electricity....

**Objective 2:** Analyze the behavior of current electricity.

- a. Draw and label the components of a complete electrical circuit that includes switches and loads (e.g., light bulb, bell, speaker, motor).
- b. Predict the effect of changing one or more of the components (e.g., battery, load, wires) in an electric circuit.
- c. Generalize the properties of materials that carry the flow of electricity using

data by testing different materials.

- d. Investigate materials that prevent the flow of electricity.
- e. Make a working model of a complete circuit using a power source, switch, bell or light, and a conductor for a pathway. (USBE, 2002, p. 9)

Selected language science students should use: complete circuit, incomplete circuit, current, conductor, insulator, pathway, power source, electromagnetism, magnetic force, magnetic field, properties, switch, and load. (USBE, 2002, p. 9)

## **Introduction to Electrical Controls and Programming**

**Unit:** Electrical Controls and Programming

**Terminal Objective 1:** Light a light bulb

**Performance Objective:** Given a light bulb, AA battery, and one hook-up wire, light the light bulb using four different circuits (ways) and sketch your solutions.

**Enabling Objectives:**

1. identify the symbols for a light bulb, battery, and hook-up wire

**Laboratory Hardware:**

- 1.5 V light bulb
- AA battery
- hook-up wire (4-6 inches long)

**Printed Documents:**

- Activity 1

**Learning Activities:**

- 1.1 Pass out Activity 1: Light a Light Bulb, 1.5V light bulb, AA battery, and hook-up wire.
- 1.2 Complete PowerPoint 1: Light a Light Bulb, along with Activity 1.

**Formative Evaluation:** Formative evaluation will be informally handled through questions by teacher and students during the activity of lighting a light bulb.





**Summative Evaluation:** All four solutions to the activity will be sketched on Activity 1: Light a Light Bulb.

**TEE**  
TECHNOLOGY AND  
ENGINEERING EDUCATION



Smasher

Hello, I am Smasher. I would like to introduce Sparky, Slippery, Shorty, and Smiley. We are going to be helping you to safely work with basic electrical components and label, draw, and wire a simple circuit.

Sparky Slippery Shorty Smiley



Dr. Gary Stewardson, Raymond Boyle

**TEE**  
TECHNOLOGY AND  
ENGINEERING EDUCATION

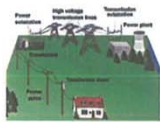

Smasher

Before we begin we would like you to discuss why electricity is so important.

Dr. Gary Stewardson, Raymond Boyle

**TEE**  
TECHNOLOGY AND  
ENGINEERING EDUCATION

### Light a Light Bulb



Given a light bulb, AA battery, and hook-up wire, light the light bulb using four different circuits (ways) and draw your solutions in the boxes provided using the symbols that you have just learned.

Sketch 1	Sketch 2
Sketch 3	Sketch 4



Dr. Gary Stewardson, Raymond Boyle

**TEE**  
TECHNOLOGY AND  
ENGINEERING EDUCATION

### Symbols



To complete this activity we need to be able to identify the symbols for the battery, light bulb, and hook-up wire. These symbols are shown below. Add light bulb sketch.

Battery Light-Bulb Hook-Up Wire

Dr. Gary Stewardson, Raymond Boyle

**TEE**  
TECHNOLOGY AND  
ENGINEERING EDUCATION

### Video



Dr. Gary Stewardson, Raymond Boyle

**Activity 1: Light a Light Bulb**

Name \_\_\_\_\_

Date \_\_\_\_\_

**Directions:** Using the light bulb, AA battery, and single piece of wire provided, experiment and complete a circuit to light the bulb. There are four possible solutions. Record your answers by sketching the solutions in the blocks below. Use the following symbols to represent the three components:

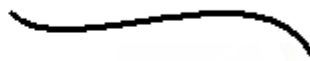

## Introduction to Electrical Controls and Programming

**Unit:** Electrical Controls and Programming

**Terminal Objective 2:** follow safety practices

**Performance Objective:** During laboratory activities, follow safety practices.

**Enabling Objectives:**

2. identify safety practices

**Laboratory Hardware:**

- None

**Printed Documents:**

- PowerPoint 2 Guided Notes
- Safety Quiz

**Learning Activities:**

- 1.3 Complete PowerPoint 2 along with Activity 2: PowerPoint Guided Notes

**Formative Evaluation:** Activity 2: PowerPoint 2 guided notes on safety will be used for formative assessment. The following are the answers to the PowerPoint guided notes:

1. Report the safety violation to the teacher
2. Jewelry
3. Anything
4. On the inside
5. Water

**Summative Evaluation:** The safety quiz will be used for summative assessment. The following are the answers to the safety quiz:

1. False
2. True
3. False
4. False
5. False

**Activity 2: PowerPoint 2 Guided Notes**

Name \_\_\_\_\_



Date \_\_\_\_\_

1. Who should you report safety violations to? \_\_\_\_\_
2. What should you never wear when working with electricity? \_\_\_\_\_
3. What should you never place on top of a power chord? \_\_\_\_\_
4. Where should you never touch a wall receptacle? \_\_\_\_\_
5. What should you never work around when working with electricity? \_\_\_\_\_

**TEE**  
TECHNOLOGY AND  
ENGINEERING EDUCATION

### Practice Safety

Hello, Shorty here. Smasher, Sparky, and myself will be helping you throughout the safety lesson.

Shorty      Smasher      Sparky

Dr. Gary Staudson, Licensed Electrician

**TEE**  
TECHNOLOGY AND  
ENGINEERING EDUCATION

### Practice Safety

Hi, Smasher again.

Working with electricity can be fun. To keep it fun, we need to discuss safety throughout this lesson. If we pay close attention to safety for ourselves and others, we will have an enjoyable time learning about electricity.





Dr. Gary Staudson, Licensed Electrician

**TEE**  
TECHNOLOGY AND  
ENGINEERING EDUCATION

### Safety Practice

One of the most important safety practices is to report any safety violations that you may see to your teacher.





Dr. Gary Staudson, Licensed Electrician

**TEE**  
TECHNOLOGY AND  
ENGINEERING EDUCATION

### Practice Safety

You should never wear jewelry when working with electricity. When jewelry comes in contact with electricity and completes a circuit, an electric shock or burn may result.





Dr. Gary Staudson, Licensed Electrician

**TEE**  
TECHNOLOGY AND  
ENGINEERING EDUCATION

### Practice Safety

You should never put anything on top of power cords. Items on power cords can damage the wires inside the cord and create a hazard.



- Question 1: What is a power cord?
- Question 2: What hazards can result by a heavy object being placed on the wire?

**Teacher's Notes:** These items need to be covered.

Q1: An electrical cord that supplies 120VAC to electrical devices.  
 Q2: An electrical short will cause heat which causes fire.  
 Q3: An electrical open can cause equipment malfunctions.





Dr. Gary Staudson, Licensed Electrician

**TEE**  
TECHNOLOGY AND  
ENGINEERING EDUCATION

### Practice Safety

Hello, Sparky here.

Touching the inside of a wall receptacle is dangerous. However, touching a household battery is safe. When we were learning about conductivity you touched a household battery and you were safe. Look up receptacle.

Dr. Gary Staudson, Licensed Electrician



 Practice Safety

Slippery here.

I wanted to tell you never to work with electricity around water. Working with electricity around water is not safe. Make sure you are working in a dry area.



© 2014 Pearson Education, Inc. All rights reserved.

 Safety Explanation

Hi, Smiley again. It is so awesome that an adult will be in the lab to help you assemble electric circuits. The teachers will be wiring the electric plug and the power source for your safety. You should never attempt to re-wire the power source because the voltage in the receptacle is dangerous if touched by the human body.



© 2014 Pearson Education, Inc. All rights reserved.

 Practice Safety

Slippery again.

Now it is time for us to complete the safety quiz. It was nice learning with you as this is the end of our lesson.



© 2014 Pearson Education, Inc. All rights reserved.

**Safety Quiz**

Name \_\_\_\_\_

Date \_\_\_\_\_

**Directions:** Circle **True** or **False** based on the action.

1. True False - You can place an unapproved object in a wall socket.
2. True False - You should never place an object on top of a power cord.
3. True False - It is safe to work with electricity around water.
4. True False - It is safe to touch the inside of a wall receptacle if there is  
no power cord plugged in.
5. True False - It is safe to wear jewelry when working with electricity.

## **Introduction to Electrical Controls and Programming**

**Unit:** Electrical Controls and Programming

**Terminal Objective 3:** Test for Conductivity

**Performance Objective:** Given a Conductivity Tester and a variety of items, test for conductivity and report results on Activity Sheet 3.

**Enabling Objectives:**

3. define conductor and insulator
4. identify conductors and insulators

**Laboratory Hardware**

- Conductivity Tester
- Test items listed on Activity 3

**Printed Documents:**

- Activity 3

**Learning Activities:**

- 1.4 Complete PowerPoint 3 along with Activity 3: Test for Conductivity.

**Formative Evaluation:** Pretest assumptions on Activity 3: Test for Conductivity will be used for formative assessment.

**Summative Evaluation:** Posttest observations on Activity 3: Test for Conductivity will be used for summative assessment.

**TEE** TECHNOLOGY AND ENGINEERING EDUCATION

### Insulators and Conductors



Hi, Slippery again. Some materials conduct electricity and are called **conductors** and some materials do not conduct electricity and are called **insulators**.

So Remember:

**Conductors** allow electricity to flow quite easily and will complete a circuit.

**Insulators** DO NOT allow electricity to flow easily and WILL NOT complete a circuit.

© Gary Swanson, Raymond State

**TEE** TECHNOLOGY AND ENGINEERING EDUCATION

### Insulators and Conductors



Now it is time for us to complete the pre-test assumptions on Activity 3: Test for Conductivity. Make sure you receive a/an:

Key	Paper clip
Wooden dowel	Bare wire
Wire with insulation	Pencil
Nail	Leather
LEGO block	Aluminum foil

© Gary Swanson, Raymond State

**TEE** TECHNOLOGY AND ENGINEERING EDUCATION

### Activity 2-1



Now that you have completed the pre-test assumptions on Activity 3: Test for Conductivity, make sure you receive a Conductivity Tester so you can complete the post-test observations. Also, be sure to answer the question at the bottom of Activity Sheet 3.

© Gary Swanson, Raymond State

**TEE** TECHNOLOGY AND ENGINEERING EDUCATION

### Conductors and Insulators

Here are two lists of items that are commonly known as insulators and conductors when working with voltages equal to or less than 12 volts.

<u><b>Insulators</b></u>	<u><b>Conductors</b></u>
Wood	Copper
Plastic	Aluminum
Glass	Most metals
Air	
<b>Human body</b>	



© Gary Swanson, Raymond State

**TEE** TECHNOLOGY AND ENGINEERING EDUCATION

### Conductors and Insulators

Here are two lists of items that are commonly known as insulators and conductors when working with 120 volts.

<u><b>Insulators</b></u>	<u><b>Conductors</b></u>
Wood	Copper
Plastic	Aluminum
Glass	Most metals
Air	<b>Human body</b>



© Gary Swanson, Raymond State

**TEE** TECHNOLOGY AND ENGINEERING EDUCATION

### Conductors and Insulators



Remember, most insulators will conduct electricity if enough voltage is supplied. For example, we mentioned that wood is an insulator when working with 12 or 120 volts; however, if lightning strikes a tree, then electricity will flow through the tree and to the ground. Lightning has a very high voltage.



© Gary Swanson, Raymond State



## Conductors and Insulators

It was fun studying conductors and insulators with you. Our next lesson will discuss electrical properties.



### Activity 3: Test for Conductivity

Name \_\_\_\_\_

Date \_\_\_\_\_

**Directions:** Under pretest assumptions, label whether you think the item listed is a conductor or insulator by writing **conductor** or **insulator** in the space provided. After completing the pretest assumptions use the Conductivity Tester to test each item and record whether it is a **conductor** or **insulator**. After completing the posttest observations, answer the question at the bottom of this activity.

Pretest Assumption	Item (material)	Posttest Observation
	Key	
	Wooden Dowel	
	Paper Clip	
	Wire with insulation	
	Bare Wire	
	Nail	
	Pencil	
	Lego Block	
	Leather	
	Aluminum Foil	

What do the conductors have in common?

## Introduction to Electrical Controls and Programming

**Unit:** Electrical Controls and Programming

**Terminal Objective 4:** Describe electrical properties and components

**Performance Objective:** Given an activity sheet and the use of PowerPoint notes, describe electrical properties and components.

**Enabling Objectives:**

5. define voltage, current and resistance
6. identify electrical components
7. match electrical components to their schematic symbols
8. draw schematic symbols of electrical components
9. describe the purpose of electrical components

**Printed Documents:**

- Activity 4
- PowerPoint 4 Guided Notes

**Learning Activities:**





- 1.5 Participate in PowerPoint 4 presentation and complete the PowerPoint 4 Guided Notes.
- 1.6 Using your PowerPoint Guided Notes, complete the lesson's Activity 4: Electrical Properties and Components.

**Formative Evaluation** The guided notes will be used to assess student progress.

**Summative Evaluation:** Activity 4: Electrical Properties and Components will be used to assess student's achievement of the lesson's performance objective.

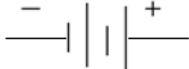
The answers to the Activity 4 are as follows:

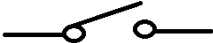
1. B
2. D
3. F
4. C
5. H
6. E

Electrical components	Schematic Symbol
7. Battery or Power Supply	
8. Hook-up Wire	
9. Switch	
10. Light Bulb	



## PowerPoint 4 Guided Notes

1. The amount of pressure pushing the electricity through a circuit is called?
- 

2. The amount of electricity flowing at a given rate through a circuit is called?
- 

3. An opposition to the flow of electricity through a circuit is called?
- 

4. List two electrical components that supply electricity. Draw the schematic symbols for these components.

Device

Schematic Symbol

---

---

5. What electrical component illuminates when the filament is heated. Draw the schematic symbol for this component?

Device

Schematic Symbol

---

6. What electrical component serves as a path for electricity in a circuit? Draw the schematic symbol for this component.

Device

Schematic Symbol

---

7. What electrical component is used to open or close an electric circuit interrupting or allowing the flow of electricity? Draw the schematic symbol for this component.



Device

Schematic Symbol

---

 **Smasher**

Hello there, I am Smasher. Sparky, Slippery, Smiley, and myself will be assisting you as we learn about the electrical properties and components.

Sparky Slippery Smiley

Dr. Ken Stambak, Raymond Barks

 **Properties of Electricity**

Hi, Slippery here. We are going to discuss some of the properties of electricity. You will need to take PowerPoint Guided Notes.

These notes will be useful later to complete your activity sheet.



Dr. Ken Stambak, Raymond Barks

 **Properties of Electricity**

Smasher here. I wanted to let you know that electricity has three properties. They are:



- **Voltage** – the amount of pressure pushing the electricity through a circuit.
- **Current** – the amount of electricity flowing at a given rate through a circuit.
- **Resistance** – the opposition to the flow of electricity through a circuit.



Dr. Ken Stambak, Raymond Barks

 **Properties of Electricity**

Another way to understand the properties of electricity is by comparing electricity to the behavior of water from a garden hose. Sparky will explain this section.

Dr. Ken Stambak, Raymond Barks

 **Voltage**

When the water tap is turned on, the release of water creates pressure. The more the tap is turned, the greater the pressure. This pressure can be compared to electricity's property of **voltage**. Voltage is the amount of pressure pushing the electricity through a circuit.



Dr. Ken Stambak, Raymond Barks

 **Current**

The rate at which the water flows from the reservoir can be compared to electricity's property of **current**.



Dr. Ken Stambak, Raymond Barks

**TEE**  
TECHNOLOGY AND  
ENGINEERING EDUCATION

## Current

Current is the amount of electricity flowing at a given rate. The greater the flow of water, the greater the rate. This rate of flow can be compared to electricity's property of current.

Higher Pressure – Higher Flow Rate      Lower Pressure – Lower Flow Rate



Dr. Gaur Vardaan, Patna, India

**TEE**  
TECHNOLOGY AND  
ENGINEERING EDUCATION

## Resistance

The nozzle on the garden hose can be compared to electricity's property of resistance. As we close the nozzle, we increase the resistance to the flow of water. Resistance in an electrical circuit is the opposition to the flow of electricity through a circuit.



Dr. Gaur Vardaan, Patna, India

**TEE**  
TECHNOLOGY AND  
ENGINEERING EDUCATION

## Components in a Circuit

Now that we discussed the three properties of electricity, let's talk about electrical components, their purpose, and their symbols. Slippery will explain the components.



Dr. Gaur Vardaan, Patna, India

**TEE**  
TECHNOLOGY AND  
ENGINEERING EDUCATION

## Battery

A battery is used to supply the electricity. The battery we used when testing for conductivity is shown below. This battery is rated at 1.5 volts (electrical pressure). The symbol for the battery is on the bottom right of this slide. We use symbols so we can easily draw the representation instead of drawing the component.



Battery      Schematic symbol for a battery

Dr. Gaur Vardaan, Patna, India

**TEE**  
TECHNOLOGY AND  
ENGINEERING EDUCATION

## Power Sources

Remember, we said that a battery can be used to supply electricity. There is another device that can supply electricity as well. This device is known as a power supply. So a battery and a power supply are similar in that they are both power sources. They also use the same symbol. Smiley is pointing to the power supply.



Power Supply      Schematic symbol for a Power Supply

Dr. Gaur Vardaan, Patna, India

**TEE**  
TECHNOLOGY AND  
ENGINEERING EDUCATION

## Light Bulb

A light bulb produces light. When electricity passes through the bulb, the filament (wire) resist the flow of electricity and increases in temperature. The resistance of the filament causes the filament to glow and emit light.



Light Bulb      Schematic Symbol for a Light Bulb

Dr. Gaur Vardaan, Patna, India

**TEE** TECHNOLOGY AND ENGINEERING EDUCATION  **Hook-up Wire**

Hook-up wire provides a path for electricity to flow from one component to another. The hook-up wire we use has a color coating on the outside of the wire. This coating is an insulator. The insulation helps keep electricity from changing paths. The symbol for wire is simply a line connecting various components.



Dr. Gary Stauden, Eastern Illinois **Wire** **Schematic symbol for Wire** 11

**TEE** TECHNOLOGY AND ENGINEERING EDUCATION  **Electrical Switch**

A switch is an electrical component that can open or close an electric circuit interrupting or allowing the flow of electricity.



**Knife Switch** **Schematic symbol for a switch** 12

**TEE** TECHNOLOGY AND ENGINEERING EDUCATION  **Electrical Switch**

An **open circuit** does not allow electricity to flow.  
A **closed circuit** allows electricity to flow.



**No flow of electricity (Open)** **Flow of electricity (Closed)** 13

**TEE** TECHNOLOGY AND ENGINEERING EDUCATION  **Light Bulb Circuit Board**

Since we know that we need a switch and a light bulb for our activities, why don't we just use a device that already has both electrical components attached. This device is known as a Light Bulb Circuit-Board.



Dr. Gary Stauden, Eastern Illinois 14

**TEE** TECHNOLOGY AND ENGINEERING EDUCATION  **Activity 4**

Now that we have completed the PowerPoint and your guided notes you should be able to complete Activity 4: Electrical Properties and Components.

Dr. Gary Stauden, Eastern Illinois 15

**Activity 4:** Electrical properties and components

Name \_\_\_\_\_ Date \_\_\_\_\_

**Directions:** Match the letter that describes the characteristics or components of electricity and electric circuits.

- |          |   |                            |
|----------|---|----------------------------|
| 1. _____ | The amount of electricity at a given rate.  | A. Voltage                 |
| 2. _____ | A device used to supply electricity   | B. Current                 |
| 3. _____ | Opposes electrical flow   | C. Hook-up Wire            |
| 4. _____ | Used as a path for electricity  | D. Power Supply or Battery |
| 5. _____ | An electrical component that can open or close an electric circuit interrupting or allowing the flow of electricity through a circuit | E. Light bulb              |
| 6. _____ | An electrical component that illuminates when the filament is heated  | F. Resistance              |
|          |   | G. Reservoir               |
|          |   | H. Switch                  |

**Directions:** In the column labeled Schematic Symbol, draw the schematic symbol for each of the following electrical components:

Electrical component	Schematic Symbol
7. Battery or Power Supply	
8. Hook-up Wire	
9. Switch	
10. Light Bulb	

## **Introduction to Electrical Controls and Programming**

**Unit:** Electrical Controls and Programming

**Terminal Objective 5:** wire a simple circuit

**Performance Objective 5:** Given a power supply, light-bulb circuit-board, hook-up wire, small slotted screwdriver, and the Electrical Controls and Programming Workbook pp. 1-11, wire a simple circuit.

**Enabling Objectives:**

10. draw a simple circuit
11. diagram the flow of electricity in a simple circuit
12. label the components in a simple circuit

**Laboratory Hardware**

- power supply
- light bulb circuit-board
- 1 red hook-up wire
- 1 black hook-up wire
- 1 blue hook-up wire
- small slotted screwdriver
- Electrical Controls and Programming Workbook

**Printed Documents:**

- Activity 5
- Activity 5-6-7
- Electrical Controls and Programming Workbook
- Performance Assessment 5

**Learning Activities:**

- 5.1 Participate in PowerPoint 5: Wire a Simple Circuit
- 5.2 Complete Activity 5: Draw, Label and Show the Flow of Electricity
- 5.3 Complete Performance Objective 5 and the student self-assessment on the Performance Assessment 5: Wire a Simple Circuit
- 5.4 Complete the simple circuit portion of the chart in Activity 5-6-7: Rate Light Bulb Brightness



**Formative Evaluation** Activity 5 will be used to assess student progress. The answers to the Activity 5 are as follows:

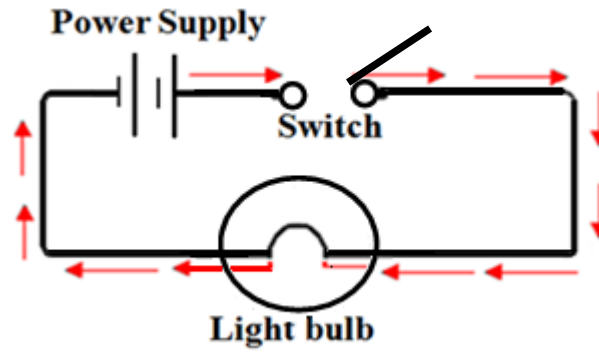

**Summative Evaluation:** The Performance Assessment 5: Wire a simple circuit, will be used to assess the student's ability to perform the terminal objective.

**TEE**  
TECHNOLOGY AND  
ENGINEERING EDUCATION



Smasher

Hello there, I am Smasher. Shorty, Smiley and myself will be assisting you as we learn how to wire a simple circuit.

When you are finished with this lesson you will be able to label, draw, and wire a simple circuit.



Shorty



Smiley

Dr. Gary Stewardson, Electrical Books

**TEE**  
TECHNOLOGY AND  
ENGINEERING EDUCATION

Simple Circuits 

Next, we attach the lines (hook-up wire) to the components. Your schematic should look like mine.

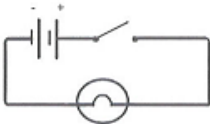

Dr. Gary Stewardson, Electrical Books

**TEE**  
TECHNOLOGY AND  
ENGINEERING EDUCATION

Simple Circuits 

Hello, Shorty again. In our previous lesson we learned the symbols for various electrical components. Now we will learn how to use these symbols to represent an electrical schematic.



Battery  
or  
Power Supply



Switch



Lamp

Dr. Gary Stewardson, Electrical Books

**TEE**  
TECHNOLOGY AND  
ENGINEERING EDUCATION

Simple Circuits 

Finally, we will label the components of our circuit. Labeling allow us to demonstrate that we know what the symbols represent. Most circuit schematics will not have labels.

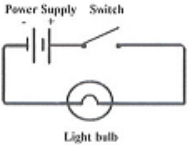

Power Supply    Switch

Light bulb

Dr. Gary Stewardson, Electrical Books

**TEE**  
TECHNOLOGY AND  
ENGINEERING EDUCATION

Simple Circuits 

First, we will draw and lay out the symbols for the electrical components.

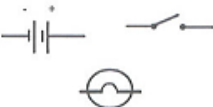

Dr. Gary Stewardson, Electrical Books

**TEE**  
TECHNOLOGY AND  
ENGINEERING EDUCATION

Simple Circuits 

Below I have demonstrated the direction of the flow of electricity when the switch is closed. As we can see, electricity flows from the positive (+) side of the power supply, through the switch (when closed), through the light bulb, and back to the negative (-) side of the power supply.

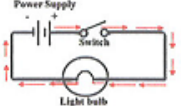

Power Supply    Switch

Light bulb

Dr. Gary Stewardson, Electrical Books



## Simple Circuits



Now that we understand schematics and how electricity flows through the represented circuit, let's complete Activity 5 and the performance objective. You will need your workbook to complete the performance objective.

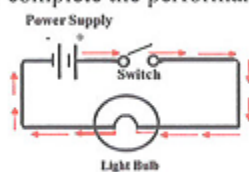

Dr. Guy Stewart-Jones, Raymond Beckley

**Activity 5: Draw, Label and Show the Flow of Electricity**

Name \_\_\_\_\_ Date \_\_\_\_\_

1. With the three symbols given below draw a schematic of a simple circuit that lights the bulb. Label the electrical components and show the flow of electricity through the circuit using arrows.

Symbols

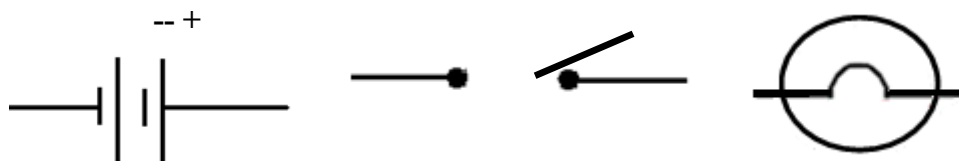

2. With the schematic above and the Electrical Controls and Programming workbook, wire a simple circuit.

### Performance Assessment 5: Wire a Simple Circuit

Name \_\_\_\_\_

Date \_\_\_\_\_

**Directions:** All steps below must receive an acceptable rating to pass this lesson.

Simple Circuit	Student Self-Assessment	Teachers Assessment	
		Acceptable	Not acceptable
1. The tinned end of the red hook-up wire is attached to the positive 12VDC terminal on the power supply and the spade (#8) terminal end of the red wire is connected to the red terminal on the knife switch.	<input type="checkbox"/>	<input type="checkbox"/>	<input type="checkbox"/>
2. The spade (#8) terminal end of the blue hookup-wire is attached to black terminal on knife switch and the spade (#6) terminal end is connected to the brass terminal screw on the #1 light bulb.	<input type="checkbox"/>	<input type="checkbox"/>	<input type="checkbox"/>
3. The spade (#6) terminal end is connected to the silver terminal screw on the light bulb and the tinned end of the black hook-up wire is attached to negative 12VDC terminal on the power supply.	<input type="checkbox"/>	<input type="checkbox"/>	<input type="checkbox"/>
4. With the power supply plugged into a 120VAC power source, the light bulb lights when the switch is closed.		<input type="checkbox"/>	<input type="checkbox"/>

Teachers Signature: \_\_\_\_\_

### Activity 5-6-7: Draw, Label and Show the Flow of Electricity

(Note: This Activity will be used in Activity 5, Activity 6, and Activity 7)

Name \_\_\_\_\_ Date \_\_\_\_\_

3. Rate the brightness of the bulb: 1 = dim 2 = bright 3 = brightest

	Bulb 1	Bulb 2	Bulb 3	When bulb is removed	Other bulb's reaction 1 = light 2 = don't light
Simple Circuit					
Series Circuit					
Parallel Circuit					

**Warning:** \*\*\* Turn off circuit and the let light bulb(s) cool so you don't burn your fingers \*\*\*

### **Introduction to Electrical Controls and Programming**

**Unit:** Electrical Controls and Programming

**Terminal Objective 6:** wire a series circuit

**Performance Objective 6:** Given a power supply, light-bulb circuit-board, hook-up wire, small slotted screwdriver, and the Electrical Controls and Programming Workbook pp. 12-20, wire a series circuit.

**Enabling Objectives:**

13. draw a series circuit
14. diagram the flow of electricity in a series circuit
15. observe the characteristics of a series circuit

**Laboratory Hardware:**

- |   |  |
|---|--|
| <ul style="list-style-type: none"> <li>• power supply</li> <li>• light-bulb circuit-board</li> <li>• small slotted screwdriver</li> <li>• Electrical Controls and Programming Workbook</li> </ul> | <ul style="list-style-type: none"> <li>• 1 red hook-up wire</li> <li>• 1 black hook-up wire</li> <li>• 1 blue hook-up wire</li> <li>• 4 white hoop-up wires</li> </ul> |
|---|--|

**Printed Documents:**

- |  |  |
|--|--|
| <ul style="list-style-type: none"> <li>• Activity 6</li> <li>• Activity 5-6-7</li> </ul> | <ul style="list-style-type: none"> <li>• Performance Assessment 6</li> <li>• Electrical Controls and Programming Workbook</li> </ul> |
|--|--|

**Learning Activities:**

- 6.1 Participate in PowerPoint 6: Wire a Series Circuit
- 6.2 Complete Activity 6: Draw and Show the Flow of Electricity
- 6.3 Complete Performance Objective, student self-assessment on the Performance Assessment 6: Wire a Series Circuit
- 6.4 Complete the series circuit portion of the chart in Activity 5-6-7: Rate Light Bulb Brightness

**Formative Evaluation:** Activity 6 will be used to assess student progress. The answers to the Activity 6 are as follows:

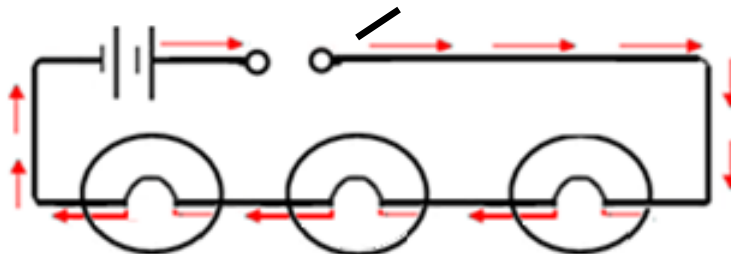



The series circuit portion of Activity 5-6-7 will also be used to assess student progress. The answers for the activity sheet 5-6-7 are as follows:

Series Circuit	1	1	1	None of the light bulbs stay illuminated.
----------------	---	---	---	---

**Summative Evaluation:** Performance Assessment 6: Wire a series circuit, will be used to assess the student's ability to wire a series circuit.





**Shorty**  **Smiley** 

Shorty here. Smiley and I will help we will explore wiring series circuits.

Dr. Gary Stewardson, Raymond Baylis



### Safety Practice

Working with electricity can be fun. To keep it fun, we will continue to use the safety practices we learned in an earlier lesson. In this section we are going to be working with series circuits.



Dr. Gary Stewardson, Raymond Baylis



### Introduction of Circuit Types

Since we have learned how to wire a simple circuit, we are now ready to explore complex circuits. The first complex circuit we will discuss is known as a **series circuit**.



Dr. Gary Stewardson, Raymond Baylis



### Series Circuits

Components of an electrical circuit can be connected in many different ways. The way components are connected determines the type of circuit.

One way components can be connected in a circuit is in series. We call this a **series circuit**.

Dr. Gary Stewardson, Raymond Baylis



### Series Circuits

In the simple circuit we only had one light bulb. By connecting more light bulbs or other devices in series with the one light bulb, our simple circuit becomes a **series circuit**.

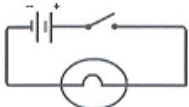
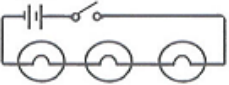
**Simple Circuit** **Series Circuit**

Dr. Gary Stewardson, Raymond Baylis



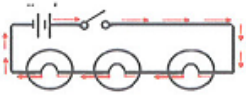

### Series Circuits

A series circuit exists when all the components are connected in-line, and electricity must flow through each component on its way from the positive (+) to the negative (-) terminal of the power source.





Dr. Gary Stewardson, Raymond Baylis

 **Series Circuits** 

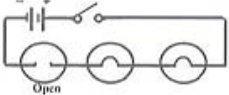
If one of the light bulbs is burnt out or disconnected, the electricity will no longer flow because there is an electrical open in the circuit, similar to when the switch is in the open or off position.



Dr. Gary Steinbock, Raymond Boyce 7

 **Laboratory Activity** 

Now that we covered series circuits, let's complete Activity 6 and the performance objective. You will need your workbook to complete the performance objective.

Dr. Gary Steinbock, Raymond Boyce 8

**Activity 6: Draw and Show the Flow of Electricity**

Name \_\_\_\_\_ Date \_\_\_\_\_

1. With the symbols below, draw a schematic of a series circuit that lights the bulbs. Show the flow of electricity through the circuit using arrows.

Symbols:

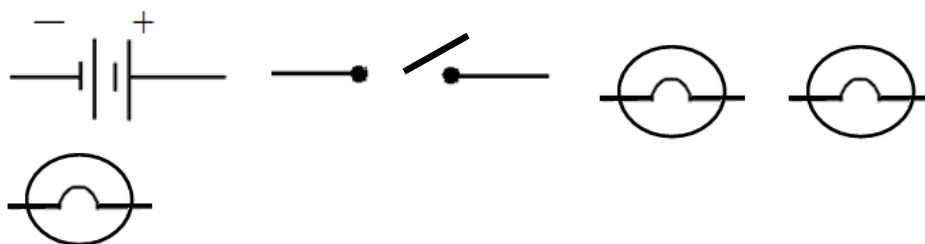

2. With the schematic above and the Electrical Controls and Programming workbook, wire a series circuit.

### Performance Assessment 6: Wire a Series Circuit

Name \_\_\_\_\_

Date \_\_\_\_\_

**Directions:** All steps below must receive an acceptable rating to pass this lesson.

Series Circuit	Student Self-Assessment	Teachers Assessment	
		Acceptable	Not Acceptable
1. The tinned end of the red hook-up wire is attached to the positive 12VDC terminal on the power supply and the spade (#8) terminal end of the red wire is connected to the red terminal on the knife switch.	<input type="checkbox"/>	<input type="checkbox"/>	<input type="checkbox"/>
2. The spade (#8) terminal end of the blue hookup-wire is attached to black terminal on knife switch and the spade (#6) terminal end is connected to the brass terminal screw on the #1 light bulb.	<input type="checkbox"/>	<input type="checkbox"/>	<input type="checkbox"/>
3. One end of the first white hook-up wire is attached to the silver terminal on the #1 light bulb and the other end is connected to the brass terminal on the #2 light bulb.	<input type="checkbox"/>	<input type="checkbox"/>	<input type="checkbox"/>
4. One end of the second white hook-up wire is attached to silver terminal on the #2 light bulb and the other end is connected to the brass terminal on the #3 light bulb.	<input type="checkbox"/>	<input type="checkbox"/>	<input type="checkbox"/>
5. The black wire's spade (#6) terminal end is connected to the silver terminal screw on the #3 light bulb and the tinned end of the black hook-up wire is attached to negative 12VDC terminal on the power supply.	<input type="checkbox"/>	<input type="checkbox"/>	<input type="checkbox"/>
6. With the power supply plugged into a 120VAC power source, the light bulb lights when the switch is closed.	<b>Wait for Teacher to check circuit</b>	<input type="checkbox"/>	<input type="checkbox"/>

Teachers Signature: \_\_\_\_\_

## Introduction to Electrical Controls and Programming

**Unit:** Electrical Controls and Programming

**Terminal Objective 7:** wire a parallel circuit

**Performance Objective 7:** Given a power supply, light-bulb circuit-board, hook-up wire, small slotted screwdriver, and the Electrical Controls and Programming Workbook pp 21-31, wire a parallel circuit.

**Enabling Objectives:**

16. draw a parallel circuit
17. diagram the flow of electricity in a parallel circuit

**Laboratory Hardware**

- |   |  |
|---|--|
| <ul style="list-style-type: none"> <li>• power supply</li> <li>• light bulb circuit-board</li> <li>• small slotted screwdriver</li> <li>• Electrical Controls and Programming Workbook</li> </ul> | <ul style="list-style-type: none"> <li>• 1 red hook-up wire</li> <li>• 1 black hook-up wire</li> <li>• 1 blue hook-up wire</li> <li>• 4 white hook-up wires</li> </ul> |
|---|--|

**Printed Documents:**

- |  |   |
|--|---|
| <ul style="list-style-type: none"> <li>• Activity 7</li> <li>• Activity 5-6-7</li> </ul> | <ul style="list-style-type: none"> <li>• Performance Assessm</li> <li>• Workbook</li> </ul> |
|--|---|

•

**Learning Activities:**

7.1 Participate in PowerPoint 7: Wire a parallel circuit

7.2 Complete Activity 6: Draw and Show the Flow of Electricity

7.3 Complete Performance Objective 7 and the student self-assessment on the Performance

Assessment 7: Wire a Parallel Circuit

7.4 Complete the parallel circuit portion of the chart in Activity 5-6-7: Rate Light Bulb Brightness

**Formative Evaluation:** Activity 7 will be used to assess student progress. The answers to the Activity 7 are as follows:

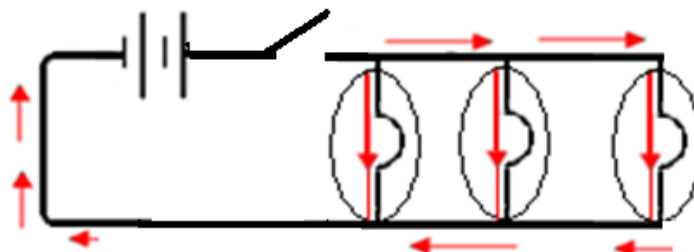

The parallel circuit portion of laboratory activity 5-6-7 will also be used to assess student progress. The answers for the Activity 5-6-7 are as follows:

Parallel Circuit (lesson 7)	3	3	3	The other light bulbs are illuminated.
-----------------------------	---	---	---	--

**Summative Evaluation:** Performance Assessment 7: wire a parallel circuit, will be used to assess the student's ability to wire a parallel circuit.

**TEE**  
TECHNOLOGY AND  
ENGINEERING EDUCATION



Smasher Slippery

Smasher here. Slippery and I will help you explore wiring parallel circuits.

Dr. Gary Stevenson, Raymond Boyd

**TEE**  
TECHNOLOGY AND  
ENGINEERING EDUCATION

### Safety Practice



Working with electricity can be fun. To keep it fun, we will continue to use the safety practices we learned in the first section. In this section we are going to be working with parallel circuits.



Dr. Gary Stevenson, Raymond Boyd

**TEE**  
TECHNOLOGY AND  
ENGINEERING EDUCATION

### Parallel Circuits

A circuit composed solely of components connected in parallel is known as a **parallel circuit**.



Dr. Gary Stevenson, Raymond Boyd

**TEE**  
TECHNOLOGY AND  
ENGINEERING EDUCATION

### Parallel Circuits



Hi, Slippery again. Remember our simple circuit? By connecting another light bulb or other component in parallel, our simple circuit becomes a **parallel circuit**.

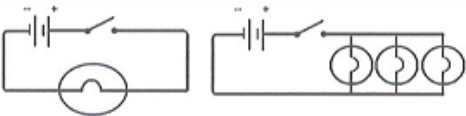

Dr. Gary Stevenson, Raymond Boyd

**TEE**  
TECHNOLOGY AND  
ENGINEERING EDUCATION

### Parallel Circuits



A parallel circuit exists when all the components are connected so that the positive lead and the negative lead of the power source have a direct path to each light bulb.

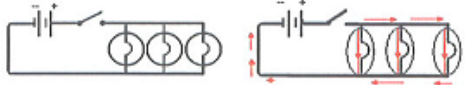

Dr. Gary Stevenson, Raymond Boyd

**TEE**  
TECHNOLOGY AND  
ENGINEERING EDUCATION

### Parallel Circuits



Notice that the positive (+) side of the power source touches all the light bulbs on one side and the negative (-) side of the battery touches the other side of all the light bulbs. So when the switch is closed, all the bulbs light with equal pressure (voltage). This is why the light bulbs in this circuit burn brighter.

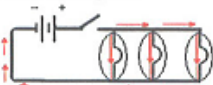

Dr. Gary Stevenson, Raymond Boyd

 **Parallel Circuits**  
TECHNOLOGY AND  
ENGINEERING EDUCATION

Unlike the series circuit, if a light bulb burns out, the other light bulbs will still illuminate. This is the result of each of the loads having an electrical path to the power source.

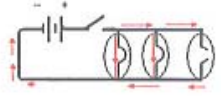

Dr. Gary Stewart, Raymond, BC 2

 **Laboratory Activity**  
TECHNOLOGY AND  
ENGINEERING EDUCATION

Now that we understand parallel circuits let's complete Activity 7.



Dr. Gary Stewart, Raymond, BC 5



**Activity 7: Draw and Show the Flow of Electricity**

Name \_\_\_\_\_ Date \_\_\_\_\_

1. With the five symbols given below, draw a schematic of a parallel circuit that lights the bulbs. Show the flow of electricity through the circuit using arrows.

Symbols

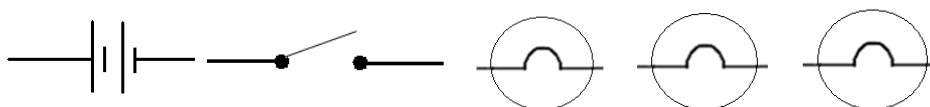

### Performance Assessment 7: Wire a Parallel Circuit

Name \_\_\_\_\_

Date \_\_\_\_\_

**Directions:** All steps below must receive an acceptable rating to pass this lesson.

Student Assessment

#### Parallel Circuit

Teachers Assessment

	Acceptable	Acceptable	Not	Acceptable
1. The tinned end of the red hook-up wire is attached to the positive 12VDC terminal on the power supply and the large (#8) spade terminal end of the red wire is connected to the red terminal on the knife switch.	<input type="checkbox"/>	<input type="checkbox"/>		<input type="checkbox"/>
2. The spade (#8) terminal end of the blue hookup-wire is attached to black terminal on knife switch and the spade (#6) terminal end is connected to the brass terminal screw on the #1 light bulb.	<input type="checkbox"/>	<input type="checkbox"/>		<input type="checkbox"/>
3. The spade (#6) terminal end of the white hook-up wire is attached to brass terminal on the # 1 light bulb and the other end is connected to the brass terminal on the #2 light bulb.	<input type="checkbox"/>		<input type="checkbox"/>	<input type="checkbox"/>
4. One end of the first white hook-up wire is attached to brass terminal on the # 2light bulb and the other end is connected to the brass terminal on the #3 light bulb.			<input type="checkbox"/>	<input type="checkbox"/>
5. One end of the second white hook-up wire is attached to silver terminal on the # 3 light bulb and other end is connected to the brass terminal on the #2 light bulb.	<input type="checkbox"/>		<input type="checkbox"/>	<input type="checkbox"/>

6. One end of the third white hook-up wire is attached to silver terminal on the #2 light bulb and other end is connected to the silver terminal on the #1 light bulb.
7. The black wire's spade (#6) terminal end is connected to the silver terminal screw on the #1 light bulb and the tinned end of the black hook-up wire is attached to negative 12VDC terminal on the power supply.
8. With the power supply plugged into a 120VAC power source, the light bulb lights when the switch is closed.



Teachers Signature: \_\_\_\_\_

## Introduction to Electrical Controls and Programming

**Unit:** Electrical Controls and Programming

**Terminal Objective 8:** wire a mechanical relay

**Performance Objective 8:** Given a power supply, mechanical relay, light-bulb circuit-board, hook-up wire, slotted screwdriver, continuity tester, and the Electrical Controls and Programming Workbook pp. 32-38, wire a an mechanical relay to control a secondary circuit.

**Enabling Objectives:**

18. draw a relay circuit
19. diagram the flow of electricity in a relay circuit

**Laboratory Hardware**

- power supply
- mechanical relay
- light bulb circuit-board
- small slotted screwdriver
- continuity tester
- magnet
- wire coil
- 1 red hook-up wire
- 1 black hook-up wire
- 1 blue hook-up wire
- 4 white hook-up wires
- electromagnet

**Printed Documents:**

- Activity 8
- Performance Assessment 8
- Electrical Controls and Programming Workbook

**Learning Activities:**

8.1 Participate in PowerPoint 8: Wire a mechanical relay

8.2 Complete Performance Objective 8 and the student self-assessment and the Performance

Assessment 8: Wire an mechanical relay

**Formative Evaluation:** Activity 8 will be used to assess student progress. The answers to the Activity Sheet 8 are as follows:

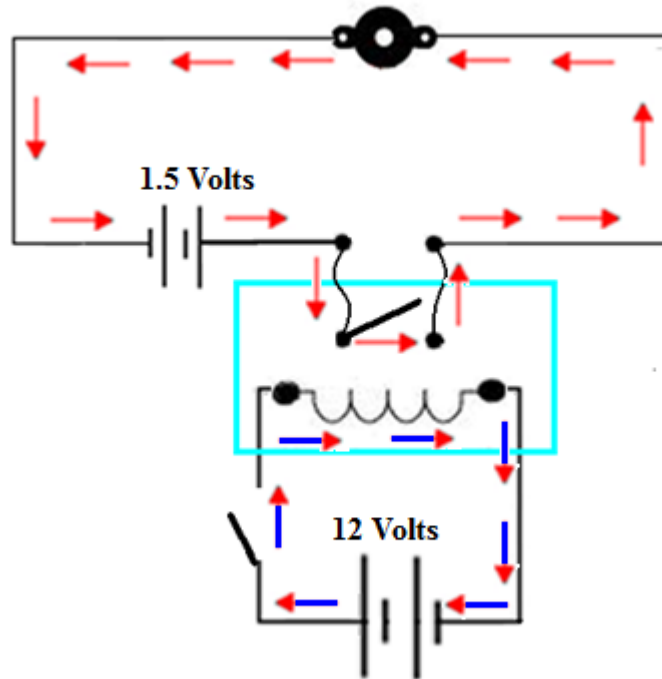

**Summative Evaluation:** Performance Assessment 8 : Wire a mechanical relay, will be used to assess the student's ability to wire a mechanical relay.

**TEE**  
TECHNOLOGY AND  
ENGINEERING EDUCATION

Shorty Smiley

Hello there. Smiley, Smasher, and myself will be assisting you as we learn how to wire a mechanical relay circuit.

When you are finished with this lesson you will be able to draw and wire a relay circuit.

Smasher

Dr. Gary Swanson, Edmond Parks

**TEE**  
TECHNOLOGY AND  
ENGINEERING EDUCATION

### Relays

In this lesson we will be discussing relays. The type of relay that we will be working with is known as a mechanical relay. A relay is simply a switch that is controlled by electricity. There are many types of relays as shown below. The relay we will work with is identified by the red arrow.



Dr. Gary Swanson, Edmond Parks

**TEE**  
TECHNOLOGY AND  
ENGINEERING EDUCATION

### Relays

Hello, Shorty again. In your first lesson, light a light bulb, you learned how to draw the schematic for the circuit. The light bulb used in this circuit is referred to as a load.



Dr. Gary Swanson, Edmond Parks

**TEE**  
TECHNOLOGY AND  
ENGINEERING EDUCATION

### Relays

If you were to replace the light bulb (load) with a coil of wire (load) we can create an electromagnet.



Dr. Gary Swanson, Edmond Parks

**TEE**  
TECHNOLOGY AND  
ENGINEERING EDUCATION

### Relays

The electromagnet is similar to a regular magnet. Question: What is the main difference between a regular magnet and an electromagnet?

**Hint: Look at the switch on the electromagnet.**



Dr. Gary Swanson, Edmond Parks

**TEE**  
TECHNOLOGY AND  
ENGINEERING EDUCATION

### Relays

That's right! You can turn off the magnetism with the electromagnet!



Dr. Gary Swanson, Edmond Parks

**TEE**  
TECHNOLOGY AND  
ENGINEERING EDUCATION

### Relays



We can use this magnetism to create an electric switch. With this circuit and a switch we can create a relay. A relay is nothing more than an electric switch.

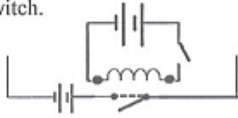



Dr Gary Swadlow, Emerald Hills

**TEE**  
TECHNOLOGY AND  
ENGINEERING EDUCATION

### Relays

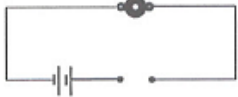

Smasher and Smiley here. Remember when we were testing continuity? Here is the schematic representation of that circuit.



Dr Gary Swadlow, Emerald Hills

**TEE**  
TECHNOLOGY AND  
ENGINEERING EDUCATION

### Relays

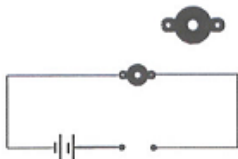

Notice the symbol for a buzzer.

Dr Gary Swadlow, Emerald Hills

**TEE**  
TECHNOLOGY AND  
ENGINEERING EDUCATION

### Relays



When we placed a conductor across the two terminals the buzzer would make a sound.

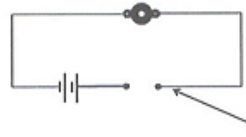

Dr Gary Swadlow, Emerald Hills

**TEE**  
TECHNOLOGY AND  
ENGINEERING EDUCATION

### Relays



The same reaction can occur with our electromagnet. We call this electrical switch a relay

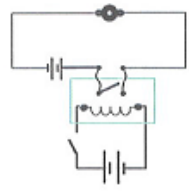

Dr Gary Swadlow, Emerald Hills

**TEE**  
TECHNOLOGY AND  
ENGINEERING EDUCATION

### Relays



Now we can draw the flow of electricity in both circuits. The solid red arrows show the flow of electricity in one loop and the red and blue arrows show the flow of electricity in the second loop.

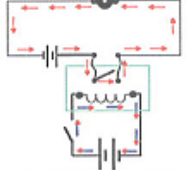

Dr Gary Swadlow, Emerald Hills

**TEE**  
TECHNOLOGY AND  
ENGINEERING EDUCATION

## Relays

We can control the 1.5 Volts in the top circuit with the 12 Volts in the relay circuit.

Dr. Gary Stewart, Starred Fields

**TEE**  
TECHNOLOGY AND  
ENGINEERING EDUCATION

## Relays

Now that we understand how a mechanical relay works in a circuit let us complete Activity 8: Wire a Mechanical Relay

Dr. Gary Stewart, Starred Fields



**Activity 8: Draw and Show the Flow of Electricity in a mechanical relay circuit.**

Name \_\_\_\_\_ Date \_\_\_\_\_

1. With the four symbols given below, draw a schematic of an electric relay circuit that causes the buzzer to buzz. Show the flow of electricity through both loops in the circuit using arrows.

Symbols

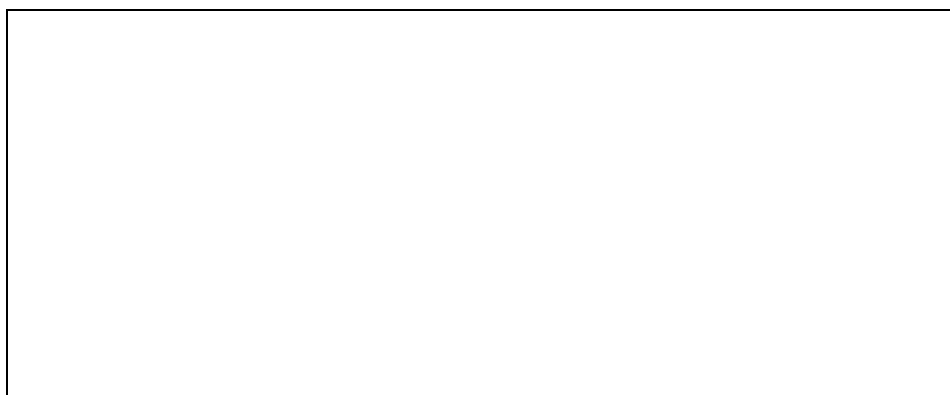
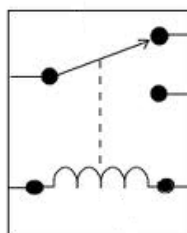
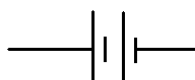

Appendix D  
Programming Curriculum

## Introduction to Electrical Controls and Programming

**Unit:** Electrical Controls and Programming

**Terminal Objective 9:** write a program to turn on individual outputs

**Performance Objective 9:** Given necessary components and the Electrical Controls and Programming Workbook pp. 39-49 & 49-61, write a program to turn on individual outputs controlling a traffic light for a specified time.

**Enabling Objectives:**

20. wire an NXT circuit
21. draw electrical flow in a relay circuit
22. demonstrate the use of the NXT's lamp and wait objects.

**Laboratory Hardware**

- LEGO NXT Controller
- Traffic Light
- 12V Power Supply
- Small slotted screw driver
- NXT Software
- Relay circuit board
- Hook-up wire

**Printed Documents:**

- Electrical Controls and Programming Workbook
- Activity 9
- Performance sheet

**Learning Activities:**

- 9.1 Participate in instructor's demonstration, while following the steps in the Electrical Controls and Programming Workbook, on how to wire the NXT circuit to control the green traffic light. Have your instructor check off your completed wiring in Activity 9 section 1. Then draw arrows to show the flow of electricity in the NXT circuit for the green light and have your instructor check off your completed drawing in Activity 9 section 2. After completing the task, have your instructor check off your program to control the green light on your Performance Assessment sheet 9.
- 9.2 Use the Electrical Controls and Programming Workbook to wire and write a program to control the yellow traffic light. Have your instructor check off your wiring and your completed representation of the flow of electricity in Activity 9 Section 3&4. After completing the task, have your instructor check off your program to control the yellow light on your Performance Assessment sheet 9.
- 9.3 Use the Electrical Controls and Programming Workbook to wire and write a program to control the red traffic light. Have your instructor check off your wiring and your completed representation of the flow of electricity in Activity 9

Section 5&6. After completing the task, have your instructor check off your program to control the yellow light on your Performance Assessment sheet 9.

**Formative Evaluation:** Wire and draw the flow of electricity and label the voltages in an NXT circuit in the Electrical Controls and Programming Workbook will be used to assess student progress. Answers to the following activity are on the next page.

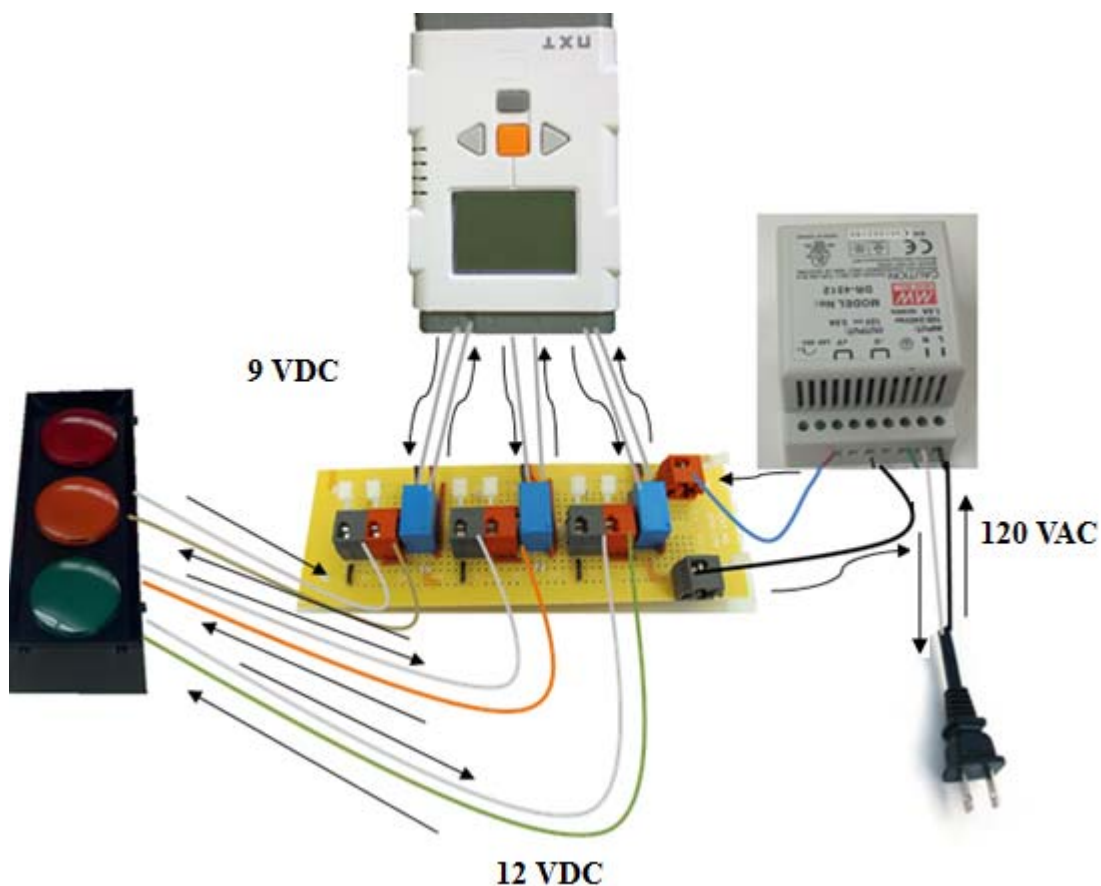

**Summative Evaluation:** Performance Assessment 9: Write a program to turn on individual outputs in the Electrical Controls and Programming Workbook, will be used to assess the student's ability.

## Activity 9: Write a program to turn on individual outputs

Name \_\_\_\_\_ Date \_\_\_\_\_

### Green Light

**Section 1: Directions:** All steps below must receive an acceptable rating to pass this lesson.

#### NXT Relay Circuit for the green light

	Student Assessment	Teachers Assessment Acceptable	Not Acceptable
A. The twisted end of the black wire is connected to the negative black power post on the relay board and the tinned end is connected to the negative (-) 12VDC power supply terminal. The twisted end of the red wire is connected to the positive red power post on the relay board and the tinned end is connected to the positive (+) 12VDC power supply terminal	<input type="checkbox"/>	<input type="checkbox"/>	<input type="checkbox"/>
B. The green wire from the traffic light is connected to the red relay post and the white wire with a green stripe is connected from the traffic light to the dark relay post for relay number 1	<input type="checkbox"/>	<input type="checkbox"/>	<input type="checkbox"/>
C. Line 1 of the relay board is plugged into Port A on the NXT Controller	<input type="checkbox"/>	<input type="checkbox"/>	<input type="checkbox"/>
D. The A/B USB cables B end is plugged into the NXT Controller and the A end is plugged into the computer's USB port.	<input type="checkbox"/>	<input type="checkbox"/>	<input type="checkbox"/>

Teachers Signature: \_\_\_\_\_

**Section 2 Green Light:** Below the arrows show the flow of electricity in the three sub-circuits. Identify the three sub-circuits by placing a circle around each sub-circuit and writing the voltage for each sub-circuit.

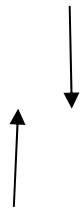
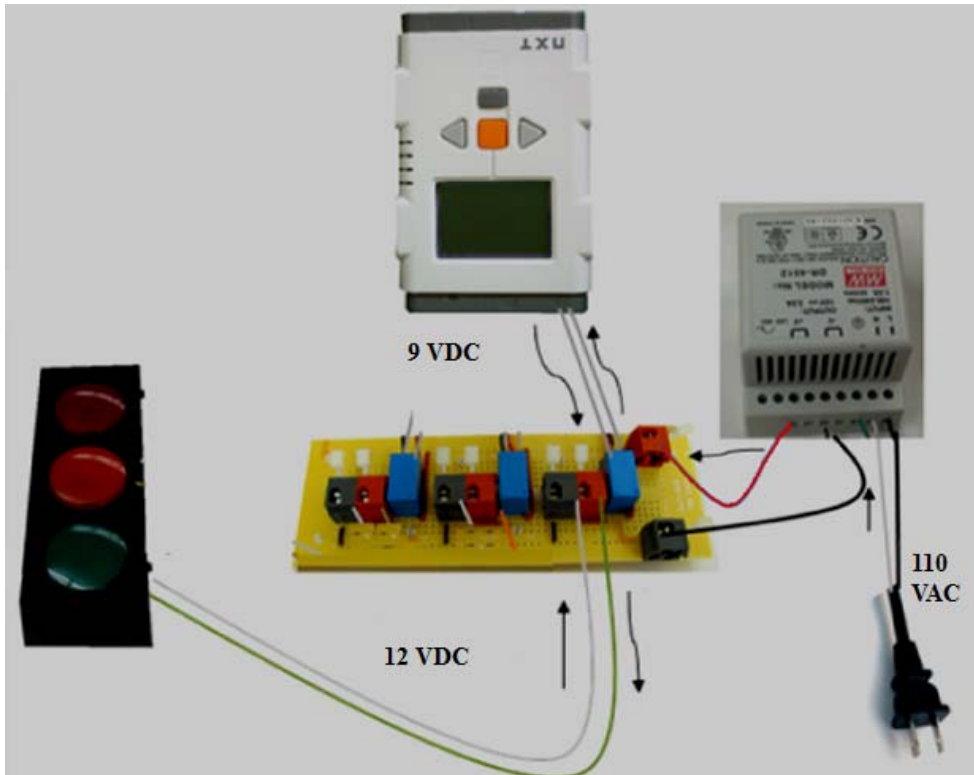

Teachers Signature: \_\_\_\_\_

Name \_\_\_\_\_

Date \_\_\_\_\_

**Section 3 Yellow Light: Directions:** All steps below must receive an acceptable rating to pass this lesson

Student  
AssessmentTeachers  
Assessment**NXT Relay Circuit**

A. The orange wire from the traffic light is connected to the yellow relay post and the white wire with a orange stripe is connected from the traffic light to the dark relay post for relay number 2

Acceptable

Not  
Acceptable

B. Line 2 of the relay board is plugged into Port B on the NXT Controller

C. The A/B USB cables B end is plugged into the NXT Controller and the A end is plugged into the computer's USB port.

Teachers Signature: \_\_\_\_\_

Name \_\_\_\_\_ Date \_\_\_\_\_

**Section 4 Yellow Light: Directions:** Using arrows, finish the drawing showing the paths of electricity on the circuit below that controls the yellow light. Also write in the various voltages associated with each sub-circuit.

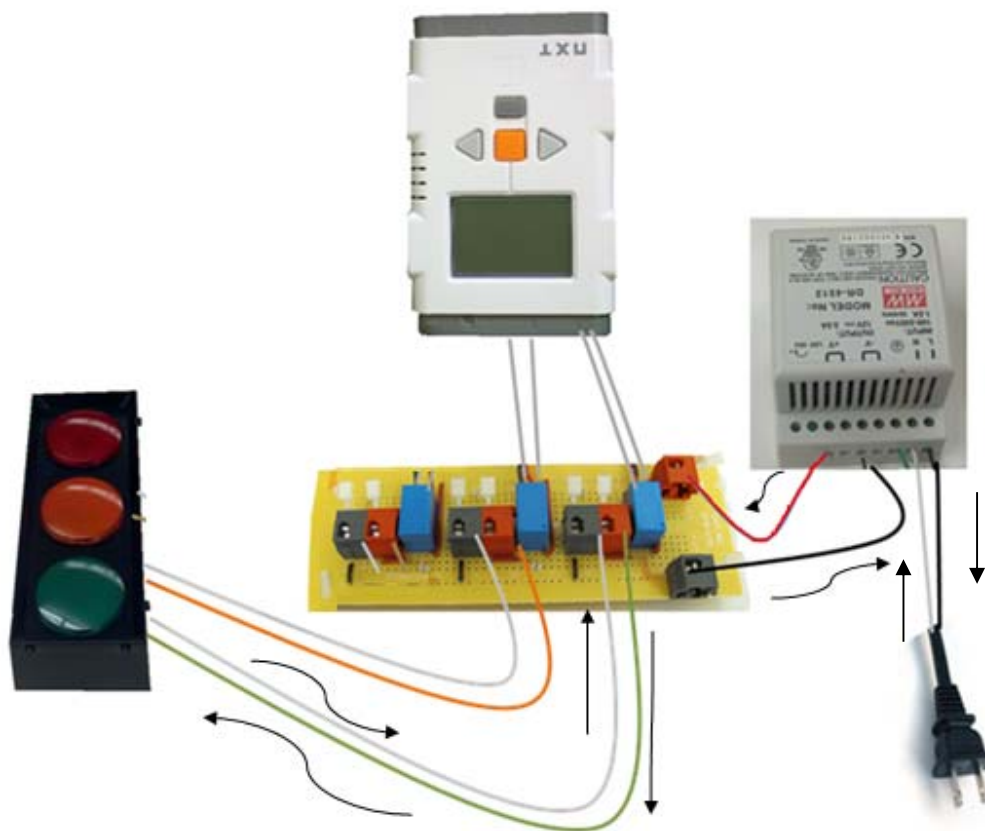

Teachers Signature: \_\_\_\_\_



Name \_\_\_\_\_

Date \_\_\_\_\_

**Section 5 Red Light: Directions:** All steps below must receive an acceptable rating to pass this lesson

	Student Assessment	Teachers Assessment	
		Acceptable	Not Acceptable
A. The brown wire from the traffic light is connected to the red relay post and the white wire with a brown stripe is connected from the traffic light to the dark relay post for relay number 3	<input type="checkbox"/>	<input type="checkbox"/>	<input type="checkbox"/>
B. Line 3 of the relay board is plugged into Port C on the NXT Controller	<input type="checkbox"/>	<input type="checkbox"/>	<input type="checkbox"/>
C. The A/B USB cable B end is plugged into the NXT Controller and the A end is plugged into the computer's USB port.	<input type="checkbox"/>	<input type="checkbox"/>	<input type="checkbox"/>

Teachers Signature: \_\_\_\_\_

Name \_\_\_\_\_ Date \_\_\_\_\_

**Section 6 Red Light: Directions:** Using arrows finish the drawing showing the paths of electricity on the circuit below that controls the red light. Also write in the various voltages associated with each sub-circuit.

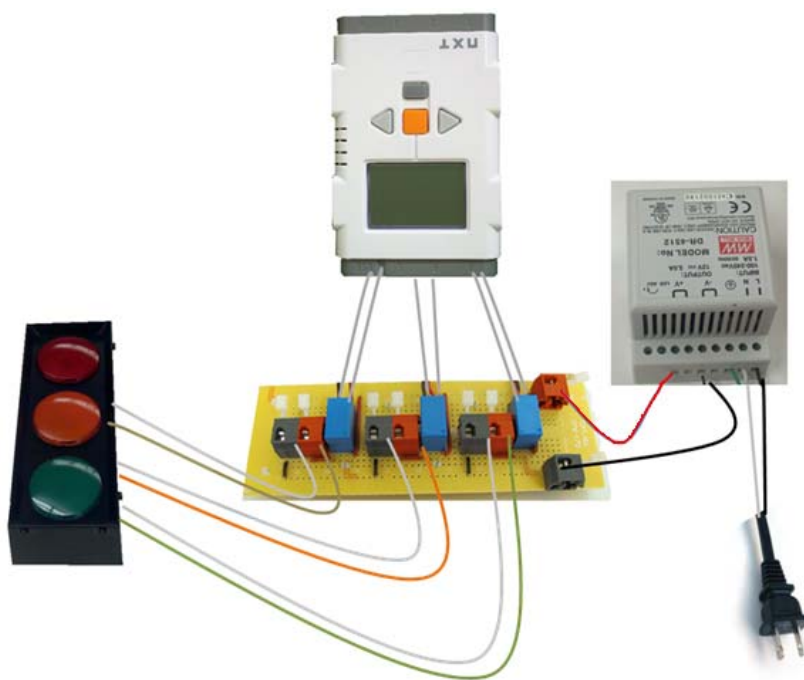

Teachers Signature: \_\_\_\_\_

**Performance Assessment 9:** Write a program to turn on individual outputs

Name \_\_\_\_\_

Date \_\_\_\_\_

- Directions:** All steps below must receive an acceptable rating to pass this lesson.

	Teachers Assessment	
	Acceptable	Not acceptable
1. The green light illuminates and stays on for two seconds	<input type="checkbox"/>	<input type="checkbox"/>
2. The yellow light illuminates and stays on for three seconds	<input type="checkbox"/>	<input type="checkbox"/>
3. The red light illuminates and stays on for one second	<input type="checkbox"/>	<input type="checkbox"/>

Teachers Signature: \_\_\_\_\_

## **Introduction to Electrical Controls and Programming**

**Unit:** Electrical Controls and Programming

**Terminal Objective 10:** write a program to control a traffic light

**Performance Objective 10:** Given a NXT circuit, and the Electrical Controls and Programming Workbook pp. 62-73, write a program to control a traffic light to operate continuously.

### **Enabling Objectives:**

23. Identify flow chart symbols
24. diagram a flowchart
25. demonstrate the use of the NXT's While Object

### **Laboratory Hardware**

- NXT circuit
- NXT Software

### **Printed Documents:**

- Activity 10 with guided notes
- Electrical Controls and Programming Workbook
- Object/Flowchart Reference Guide

### **Learning Activities:**

- 10.1 Watch Traffic Light Video
- 10.2 Participate in the instructor's PowerPoint 10 presentation: Flowcharts, and complete the guided notes in Activity 10
- 10.3 Complete Activity 10 with guided notes
- 10.4 Complete the Electrical Controls and Programming Workbook activity:  
Write a program to control a traffic light

**Formative Evaluation:** Activity10 with guided notes will be used to assess student progress.

The answers to Activity 10 with guided notes are as follows: **Please note: There are a variety of ways to flowchart this program. The flow chart below represents one solution.**

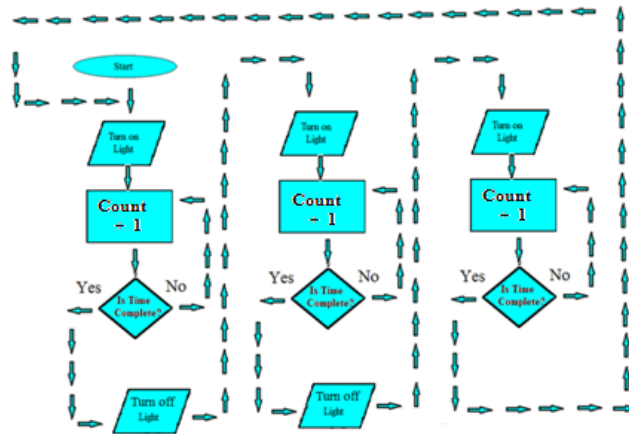

**Summative Evaluation:** Performance Assessment 10: Write a program to control a traffic light will be used to assess the student's ability to write a program to control a traffic light to operate continuously.

**TEE**  
TECHNOLOGY AND  
ENGINEERING EDUCATION

## Flowcharts



Hello again, Sparkey here. Slippery and I will help you explore how to create a program that simulates outputs on a traffic light. Make sure you have your guided notes.

Dr. Gary Stewardson, Raymond Boyce

1

**TEE**  
TECHNOLOGY AND  
ENGINEERING EDUCATION

## Flowcharts



Flowcharts can be a useful tool that better enable us to organize, problem solve, and brainstorm when we are writing a program. Flowcharts are similar to thinking maps and concept maps we use to organize, problem solve, and brainstorm when we are writing a paper.

Dr. Gary Stewardson, Raymond Boyce

2

**TEE**  
TECHNOLOGY AND  
ENGINEERING EDUCATION

## Flowcharts



In our last program, we wrote a program to turn on a light for two seconds. Let's use symbols to represent the logical flow of this program.

Dr. Gary Stewardson, Raymond Boyce

3

**TEE**  
TECHNOLOGY AND  
ENGINEERING EDUCATION

## Symbols



Start and Stop symbols represent the beginning or end of a program. These symbols are simply a place holder and are oval.

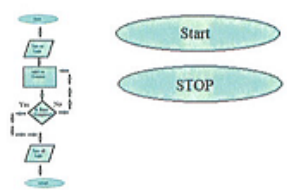

Dr. Gary Stewardson, Raymond Boyce

4

**TEE**  
TECHNOLOGY AND  
ENGINEERING EDUCATION

## Symbols



Input and outputs from the computer can be represented by the parallelogram symbol below. We use this symbol to represent when we turned the light on.

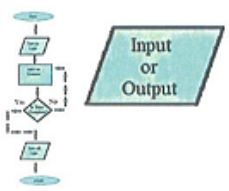

Dr. Gary Stewardson, Raymond Boyce

5

**TEE**  
TECHNOLOGY AND  
ENGINEERING EDUCATION

## Symbols



We can also use this symbol to represent a switch or a touch sensor.

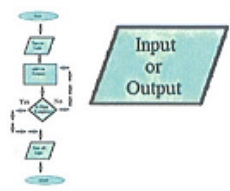

Dr. Gary Stewardson, Raymond Boyce

6

**TEE**  
TECHNOLOGY AND  
ENGINEERING EDUCATION

### Symbols

Process symbols represent computational action as rectangles or blocks and represent "Action". For example, we use this symbol to represent the timer counting two seconds.

Dr. Gary Stevenson, Raymond Bayes

7

**TEE**  
TECHNOLOGY AND  
ENGINEERING EDUCATION

### Symbols

The decision symbol represents a yes/no and is in the shape of a diamond. We use this symbols to represent testing if the counter has counted to two.

Dr. Gary Stevenson, Raymond Bayes

8

**TEE**  
TECHNOLOGY AND  
ENGINEERING EDUCATION

### Symbols

The decision symbol can also represent if a switch or a touch sensor is pushed or not.

Dr. Gary Stevenson, Raymond Bayes

9

**TEE**  
TECHNOLOGY AND  
ENGINEERING EDUCATION

### Symbols

The arrow symbols represent the direction of flow in a program. The arrow symbols shows how the logic flows in a computer program.

Dr. Gary Stevenson, Raymond Bayes

10

**TEE**  
TECHNOLOGY AND  
ENGINEERING EDUCATION

### Complete Flowchart

The connection of all the symbols shows a process. The flowchart to the right represents the process of turning a light on for two seconds, then turning off the light, and then ending the program.

Dr. Gary Stevenson, Raymond Bayes

11

**TEE**  
TECHNOLOGY AND  
ENGINEERING EDUCATION

### Complete Flowchart

1. Start the process
2. Turn on the light
3. - If (Yes) the time has expired then: Go to Stop  
- If (No) the time has not expired then keep counting
4. Turn off the light
5. Stop

Dr. Gary Stevenson, Raymond Bayes

12

**TEE** TECHNOLOGY AND ENGINEERING EDUCATION

### Flow Chart Activity

Our next program will perform the following so please write these down in your activity guided notes:

- The green light and red light will turn on for two seconds.
- The green and red light will turn off.
- The green and yellow light will turn on for one second
- The green and yellow light will turn off

Dr. Gary Brownstein, Raymond Boyes

**TEE** TECHNOLOGY AND ENGINEERING EDUCATION

### Flow Chart Activity

Wiring:

- The green light is connected to Port A of the NXT controller and relay 1 on the relay board.
- The yellow light is connected to Port B of the NXT controller and relay 2 on the relay board
- The red light is connected to Port C of the NXT controller and relay 3 on the relay board

Dr. Gary Brownstein, Raymond Boyes

**TEE** TECHNOLOGY AND ENGINEERING EDUCATION

### Pre-Programming Activity

With the symbols below and the PowerPoint guided notes, create a flow chart that represents a computer program that will logically follow the steps you have just written in your Activity 10 guided notes.

Dr. Gary Brownstein, Raymond Boyes

**TEE** TECHNOLOGY AND ENGINEERING EDUCATION

### Flow Chart

Your flow chart should look something like the flowchart pictured to the right.

Dr. Gary Brownstein, Raymond Boyes

**TEE** TECHNOLOGY AND ENGINEERING EDUCATION

### Flow Chart

NXT Object Reference

Your computer program should look something like the flowchart pictured to the right.

Dr. Gary Brownstein, Raymond Boyes



**TEE** TECHNOLOGY AND ENGINEERING EDUCATION

### Complete Flowchart

Can you flowchart the process of a traffic light?

Dr. Gary Brownstein, Raymond Boyes



 **Complete Flowchart**  

Now, let us complete Activity 10

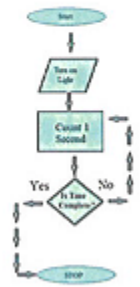

```
graph TD; Start([Start]) --> TurnOnTable[/Turn on Table/]; TurnOnTable --> Count1Second[Count 1 Second]; Count1Second --> IsTimeComplete{Is Time Complete?}; IsTimeComplete -- Yes --> Stop([Stop]); IsTimeComplete -- No --> Count1Second;
```

Dr. Gary Stevenson, Raymond Bayns 19

**Activity 10 with Guided Notes:** Diagram a flowchart for a traffic light

Name \_\_\_\_\_ Date \_\_\_\_\_

1. **Directions:** Draw the flowchart as presented by the PowerPoint:

A. Draw the flowchart symbols for start and Stop and state their purposes in accordance with the :

Flowchart Symbol	Purpose
	Represents the beginning of a computer program

B. Draw the flowchart symbol for Input/Output and state the purpose:

Flowchart Symbol	Purpose

C. Draw the flowchart symbol for a process and state the purpose:

Flowchart Symbol	Purpose

D. Draw the flowchart symbol for Decision and state the purpose:

Flowchart Symbol	Purpose

E. Draw the flowchart symbol for Flow and state the purpose:

Flowchart Symbol	Purpose

Teachers Signature: \_\_\_\_\_

2. List the steps of the computer program presented in the PowerPoint discussion.
  
3. In the column below, use flowchart symbols to draw a flowchart that represents a computer program that was just discussed.

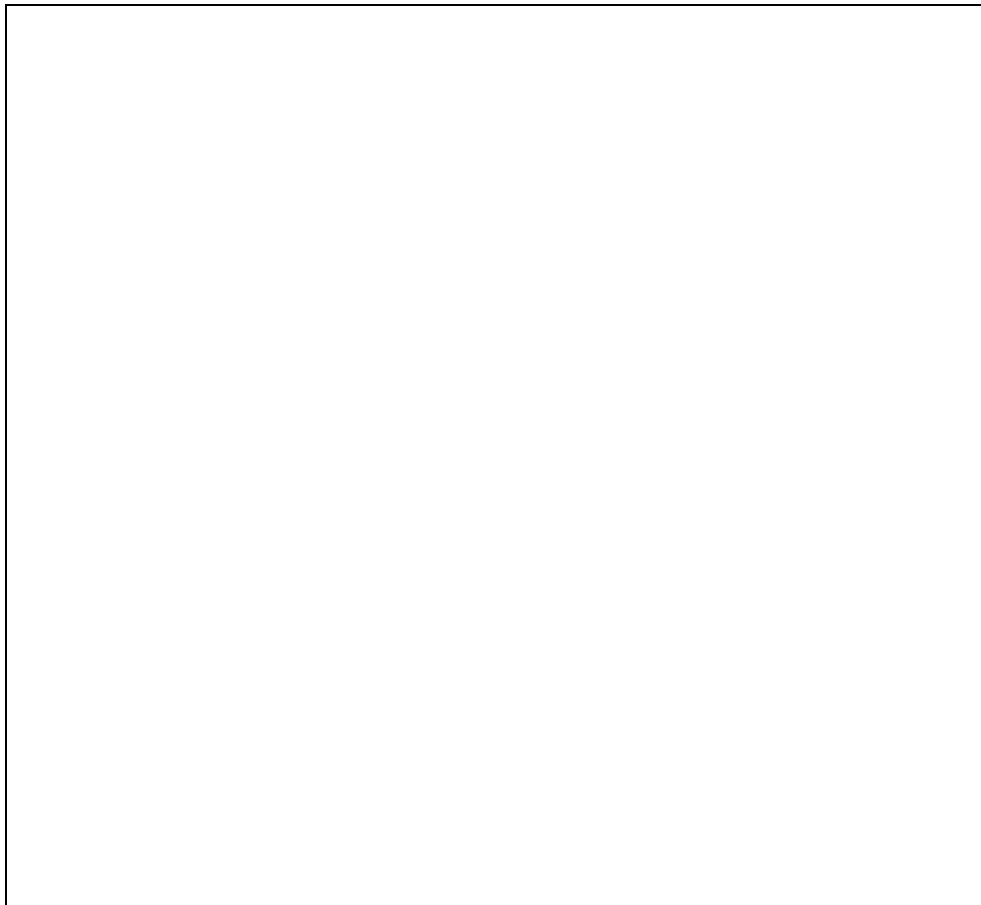
A large, empty rectangular box with a thin black border, intended for drawing a flowchart. The box is centered horizontally and occupies a significant portion of the page's width and height.

Teachers Signature: \_\_\_\_\_

4. **Directions:** With the use of NXT software, develop the computer program according to your flowchart.

5. **Directions:** Watch the video titled Traffic Light and record the time of the lights being illuminated in the table below.

Light	Time:
Green	
Yellow	
Red	

Teachers Signature: \_\_\_\_\_

**6. Directions:** Using the symbols below, diagram a flowchart that represents the logical function of a traffic light that runs continuously. Next, have your instructor verify your flow chart.

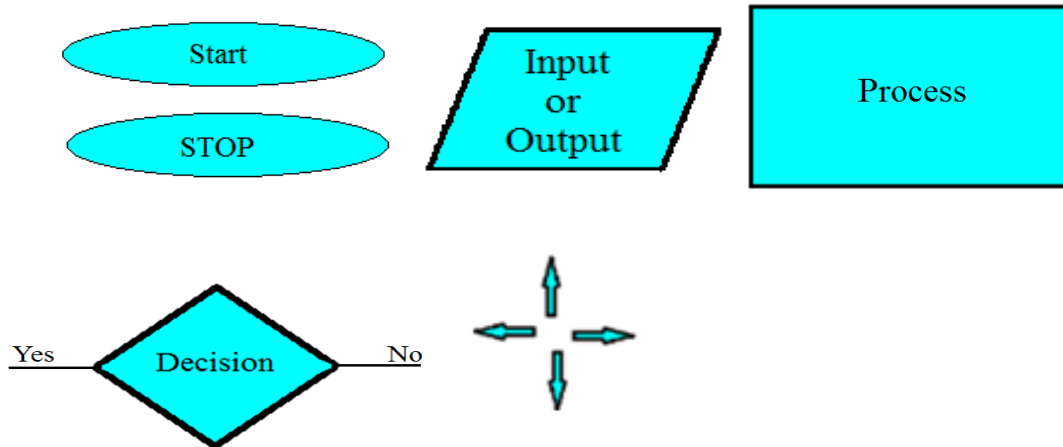

A large empty rectangular box with a black border, intended for the student to draw their flowchart.

Teachers Signature: \_\_\_\_\_

**7. Directions:** Write the program for the NXT controller to simulate the traffic light and demonstrate your work to your instructor.

Teachers Signature: \_\_\_\_\_

**Performance Assessment 10:** Write a program to control a traffic light

Name \_\_\_\_\_

Date \_\_\_\_\_

**Directions:** All steps below must receive an acceptable rating to pass this lesson.

**Traffic Light**

	Student Assessment	Teachers Assessment Acceptable	Not acceptable
1. Does traffic light function in the proper sequence	<input type="checkbox"/>	<input type="checkbox"/>	<input type="checkbox"/>
2. Do the various lights stay on for the appropriate time	<input type="checkbox"/>	<input type="checkbox"/>	<input type="checkbox"/>
3. Does the light continuously cycle	<input type="checkbox"/>	<input type="checkbox"/>	<input type="checkbox"/>

Teachers Signature: \_\_\_\_\_



**Performance Assessment 10:** Write a program to control a traffic light

Name \_\_\_\_\_











Date \_\_\_\_\_

**Directions:** All steps below must receive an acceptable rating to pass this lesson.

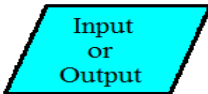
		Student Assessment	Teachers Assessment	
			Acceptable	Not acceptable
1.	<b>Traffic Light</b> Does traffic light function in the proper sequence	<input type="checkbox"/>	<input type="checkbox"/>	<input type="checkbox"/>
2.	Do the various lights stay on for the appropriate time	<input type="checkbox"/>	<input type="checkbox"/>	<input type="checkbox"/>
3.	Does the light continuously cycle	<input type="checkbox"/>	<input type="checkbox"/>	<input type="checkbox"/>

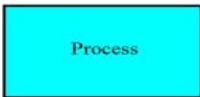
Teachers Signature: \_\_\_\_\_

### Object/Flowchart Reference Guide

Object	Flow Chart Symbol
	
	
	
	
	
	

## Introduction to Electrical Controls and Programming

**Unit:** Electrical Controls and Programming

**Terminal Objective 11:** write a program to control a traffic light based on the input of a switch.

**Performance Objective 11:** Given a NXT circuit, and the Electrical Controls and Programming Workbook pp.74-96, write a program to control a traffic light based on the input of a switch

**Enabling Objectives:**

26. write a program to illuminate a light based on the input of a switch
27. diagram a flowchart to represent controlling a traffic light based on the input of a switch

**Laboratory Hardware**

- NXT wired circuit
- Pencil
- NXT Software
- NXT Touch Sensor

**Printed Documents:**

- Electrical Controls and Programming Workbook
- Object Flowchart Reference Guide

**Learning Activities:**

- 11.1 Complete the Electrical Controls and Programming Workbook: Write a program to control a light based on the input of a switch with Activity 11-1 and 11-2.
- 11.2 Complete Activity 11- 2: Diagram a flowchart to control a traffic light based on the input of a switch
- 11.5 Complete the Electrical Controls and Programming Workbook: Write a program to control a traffic light based on the input of a switch activity.

**Formative Evaluation:** Activity 11.1 and Activity 11.2 will be used to assess student progress. The answers to the Activity Sheet 11.1 and Activity 11.2 are as follows: **Please note: There are a variety of ways to flowchart this program. The flow charts below represent one solution.**

**Activity 11.1**

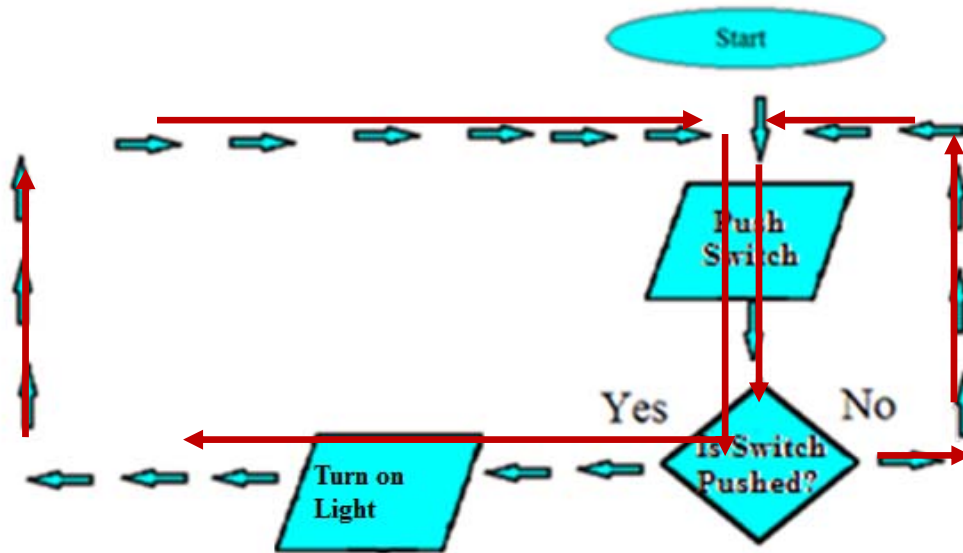

**Activity 11.2**

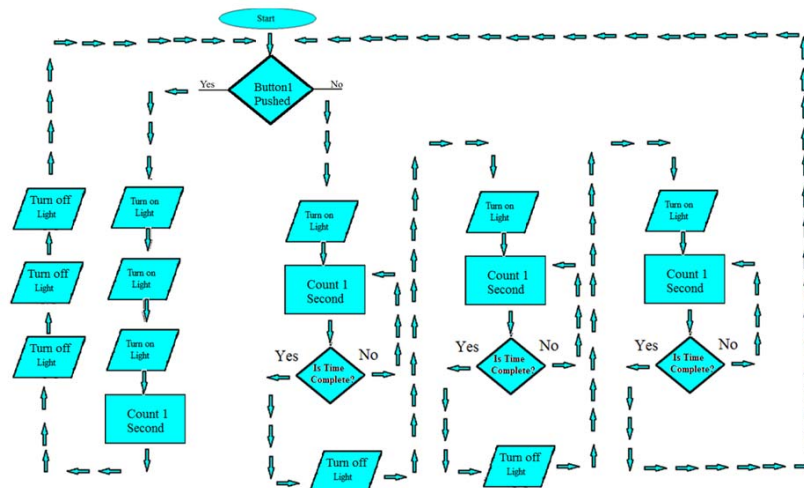

**Summative Evaluation:** Performance Assessment 11 will be used to assess the student's ability write a program to control a traffic light based on the input of a switch.

**Activity 11.1:** Diagram a flowchart that represents a program that waits for a touch sensor to be depressed.

Name \_\_\_\_\_ Date \_\_\_\_\_

**1. Directions:** Using the flow chart below, first draw arrows representing program flow if the touch sensor (switch) is pressed. Next, draw arrows representing program flow if the touch sensor (switch) is not pushed.

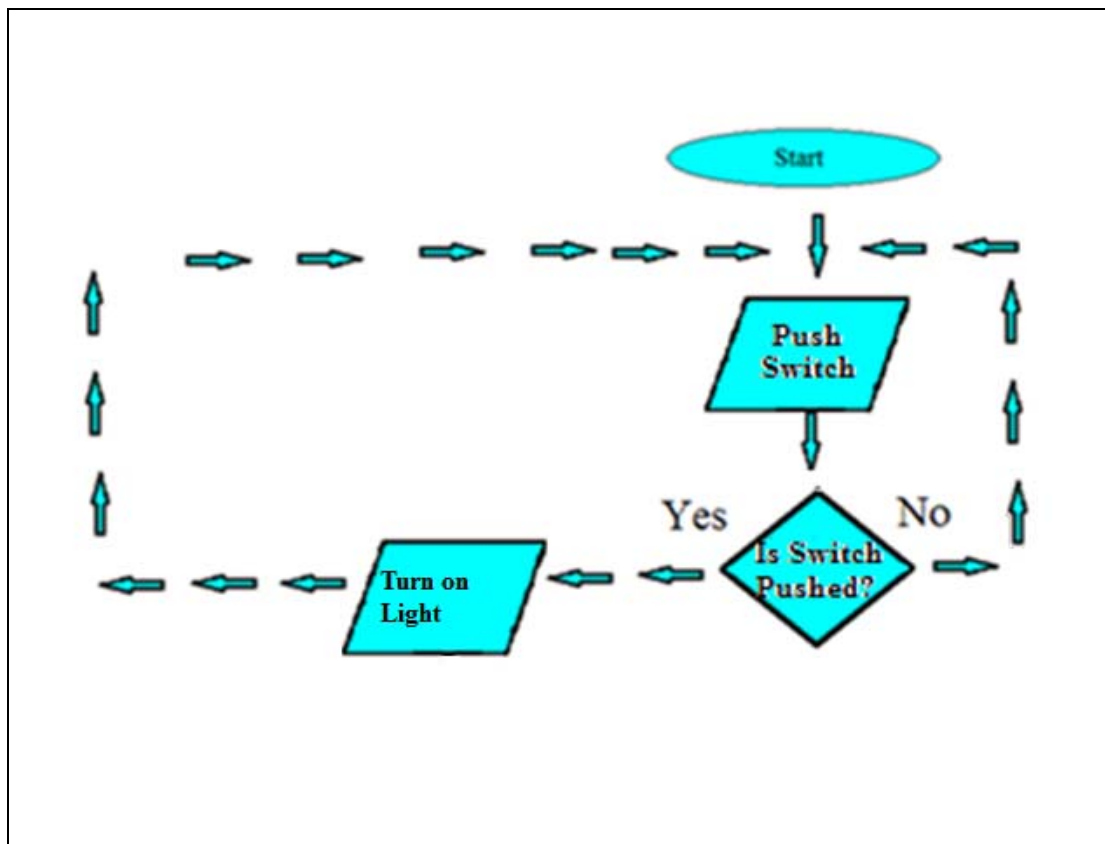

**Activity 11.2:** Diagram a flowchart for a traffic light based on the input of a switch

Name \_\_\_\_\_ Date \_\_\_\_\_

**1. Directions:** Using the symbols below draw a flowchart that represents the process of a traffic light that functions normally but when a touch sensor pressed, all lights turn on and off every two seconds.

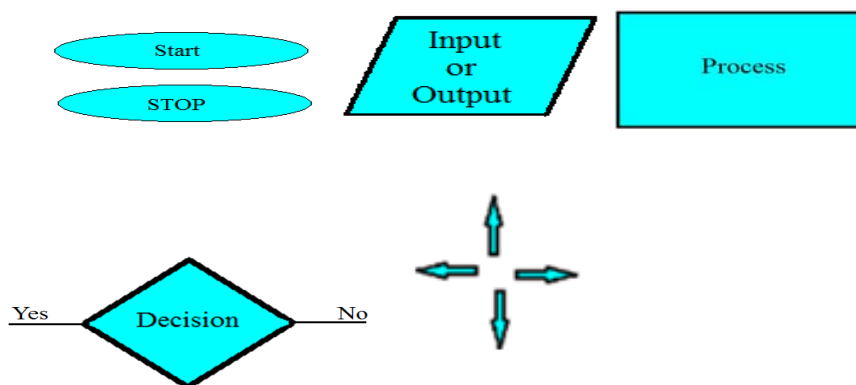

A large empty rectangular box provided for drawing the flowchart.

**Performance Assessment 11:** Write a program to control a traffic light based on the input of a switch

Name \_\_\_\_\_

Date \_\_\_\_\_

- Directions:** All steps below must receive an acceptable rating to pass this lesson.

Student  
Assessment

Teachers  
Assessment

**Program to control a traffic light based on the input of a switch**

Acceptable      Not  
Acceptable

1. Traffic light functions normally
2. When button is pushed, all lights blink on and off every two seconds







Teachers Signature: \_\_\_\_\_

## Introduction to Electrical Controls and Programming

**Unit:** Electrical Controls and Programming

**Terminal Objective 12:** Write a program to control a Ping-Pong ball feeder

**Performance Objective 12:** Given a NXT circuit, and the Electrical Controls and Programming Workbook pp. 97-111: Write a program to control a Ping-Pong ball feeder that will deliver a Ping-Pong ball every two seconds.

**Enabling Objectives:**

28. Diagram a flowchart that represents a Ping-Pong ball feeder that delivers a Ping-Pong ball every two seconds.

**Laboratory Hardware:**

- NXT wired circuit
- Pencil
- NXT Software

**Printed Documents:**

- Electrical Controls and Programming Workbook
- Object/Flowchart Reference Guide
- Activity 12

**Learning Activities:**

12.1 Complete Activity 12: Diagram a flowchart for a ping pong ball feeder

12.2 Complete the Electrical Controls and Programming Workbook: Write a program to energize two solenoids activity. Then complete the Electrical Controls and Programming Workbook activity: Write a program to feed Ping-Pong balls every two seconds.



**Formative Evaluation:** Activity 12 will be used to assess student progress. The answers to the Activity Sheet 12 are as follows

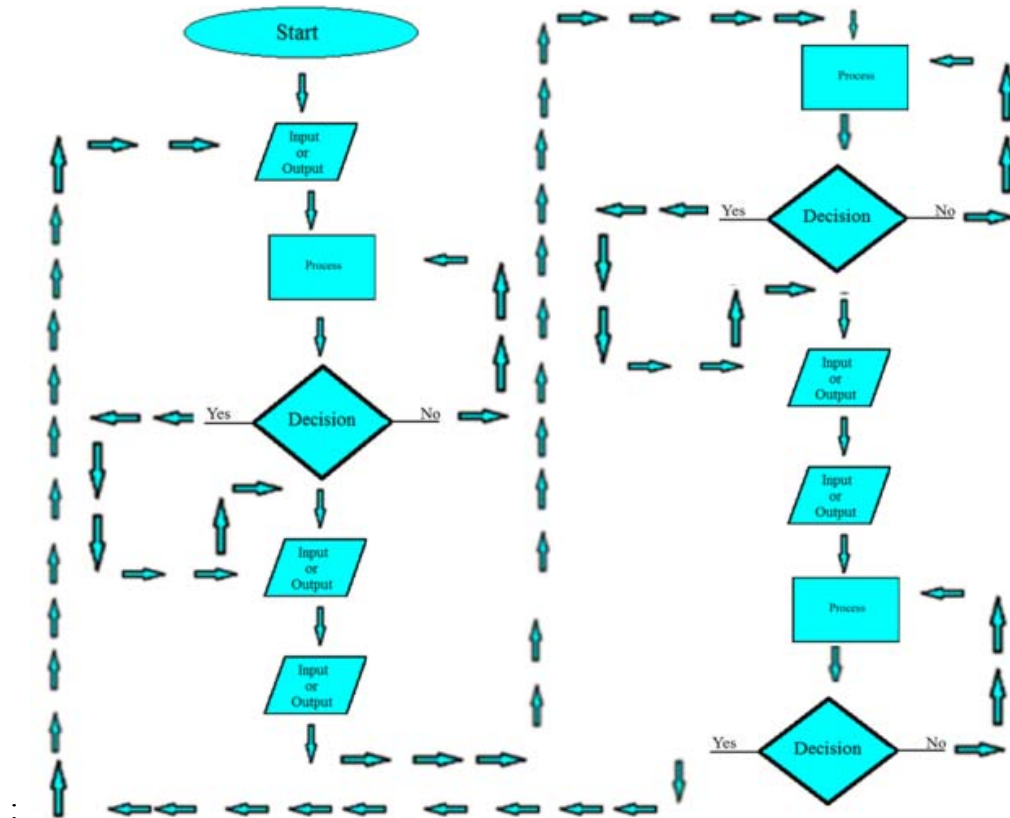

**Summative Evaluation:** Performance Assessment 12 will be used to assess the student's ability to program Ping-Pong ball feeder that delivers a Ping-Pong ball every two seconds.

## Introduction to Electrical Controls and Programming

**Unit:** Electrical Controls and Programming

**Terminal Objective 13:** write a program to control a Ping-Pong ball feeder based inputs

**Performance Objective 13:** Given a NXT circuit and the Electrical Controls and Programming Workbook pp.112-117: Write a program to control a Ping-Pong ball feeder that will deliver a Ping-Pong ball every two seconds.

**Enabling Objectives:**

29. Diagram a flowchart that will enable a Ping-Pong ball feeder to deliver a Ping-Pong ball every two seconds or four seconds based on the input of two switches.

**Laboratory Hardware**

- Modified NXT wired circuit
- Pencil
- NXT Software
- 2-NXT Touch Sensors

**Printed Documents:**

- Electrical Controls and Programming Workbook
- Object/Flowchart Reference Guide
- Activity 13

**Learning Activities:**

13.1 Complete Activity 13: Diagram a flowchart that will enable a Ping-Pong ball feeder to deliver a ping pong balls based on the input of two switches.

13.2 Complete Activity 13: Write a program to control a Ping-Pong ball feeder based on the input of two switches.

13.3 Complete the Electrical Controls and Programming Workbook activity Write a program to control a Ping-Pong ball feeder based on the input of two switches.

**Formative Evaluation:** Laboratory Activity 13 will be used to assess student progress. The answers to the Activity Sheet 13 are as follows: **Please note: There are a variety of ways to flowchart this program. The flow chart below represents one solution**

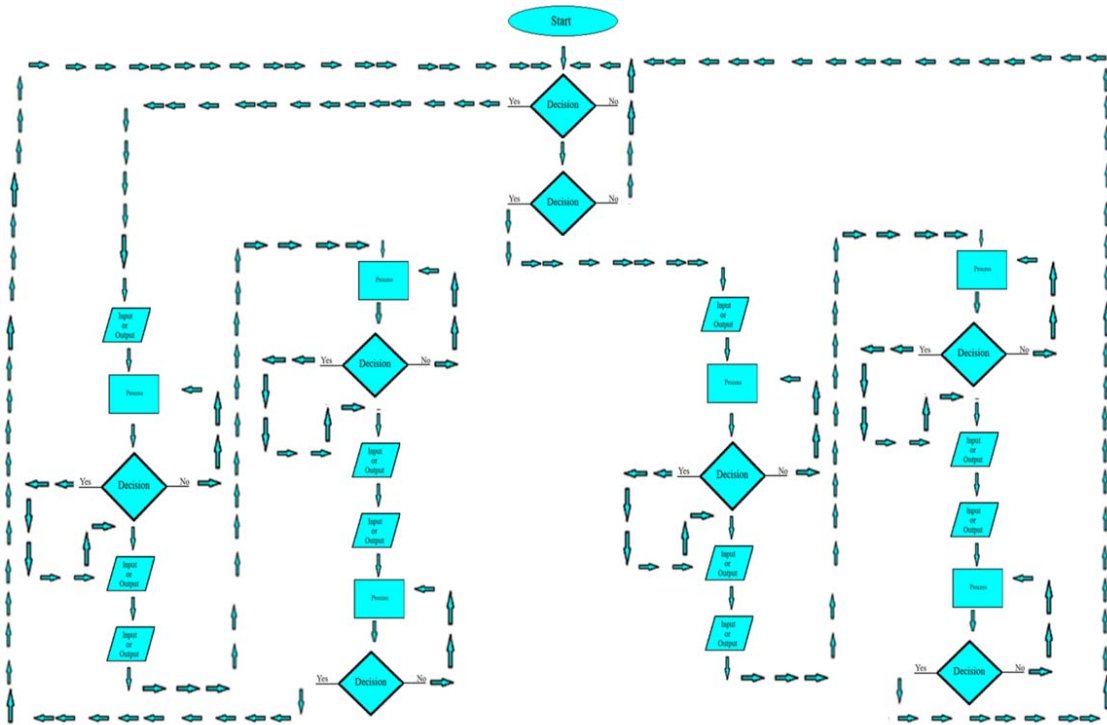

**Summative Evaluation:** Performance Assessment 13 will be used to assess the student's ability to program a Ping-Pong ball feeder to deliver a Ping-Pong ball every two seconds or four seconds based on the input of two switches.

**Activity 13:** Diagram a flowchart that will enable a Ping-Pong ball feeder to deliver a Ping-Pong ball based on the input of two switches.

Name \_\_\_\_\_ Date \_\_\_\_\_

**1. Directions:** Using the symbols below draw a flowchart that represents the process of a Ping-Pong ball feeder that holds 3 ping pong balls. When button one is pushed the feeder will deliver a Ping-Pong ball every two seconds. When button two is pushed, the feeder will deliver every four seconds.

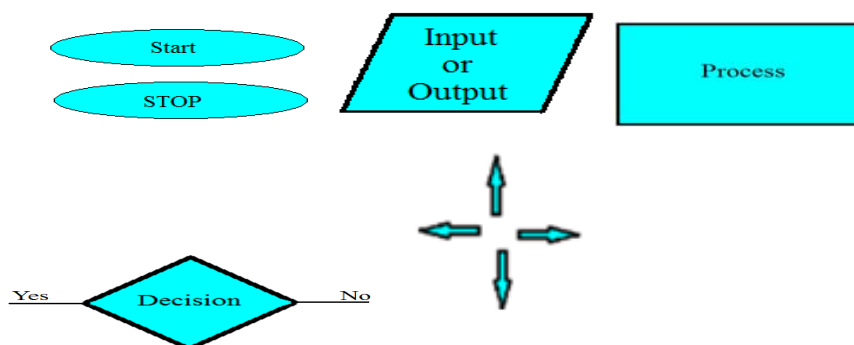

A large empty rectangular box with a black border, intended for drawing the flowchart.

**Performance Assessment 13:** Write a program to control a Ping-Pong ball feeder based on the input of two switches

Name \_\_\_\_\_

Date \_\_\_\_\_

- . **Directions:** All steps below must receive an acceptable rating to pass this lesson.

Student  
Assessment

Teachers  
Assessment

**Program to control a traffic light based on the input of two switches**

Acceptable      Not  
acceptable

1. Feeder holds all the Ping-Pong balls



2. When button 1 is pushed, the feeder outputs 1 ball every 2 seconds



3. When button 2 is pushed, the feeder outputs 1 ball every 4 seconds





Teachers Signature: \_\_\_\_\_

Appendix E  
Curriculum Workbook

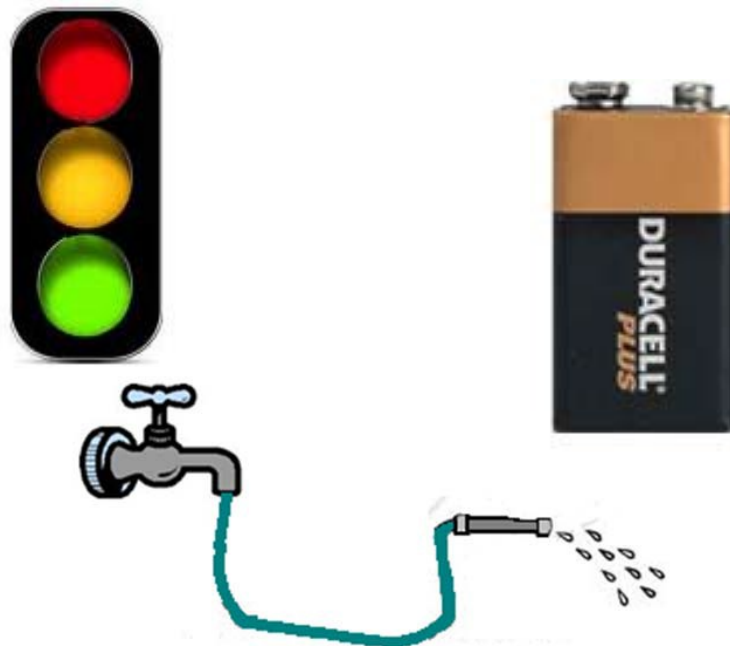

# Electrical Controls and Programming Workbook



## Component Descriptions Page 3

Performance Assessment 5: Wire a simple circuit	Pages 4-11
Performance Assessment 6: Wire a series circuit	Pages 12-20
Performance Assessment 7: Wire a parallel circuit	Pages 21-31
Performance Assessment 8: Wire a mechanical relay	Pages 32-38
Performance Assessment 9: Wire the NXT Circuit to control the traffic light	Pages 39-49
Performance Assessment 10: Write a program to turn on individual lights on a traffic light.	Pages 50-61
Performance Assessment 11: Write a program to control a Traffic light	Pages 62-73
Performance Assessment 12: Write a program to control a traffic light based on the input of a switch	Pages 74-96
Performance Assessment 13: Write a program to energize two solenoids	Pages 97-105
Performance Assessment 14 Write a program to feed Ping-Pong balls every two seconds	Pages 106-111
Performance Assessment 15 Write a program control a Ping-Pong ball feeder based on inputs	Pages 112-117



# Descriptions:



#8 Spade Connector



#6 Spade Connector



Tinned Wire



Brass terminal



Silver Terminal

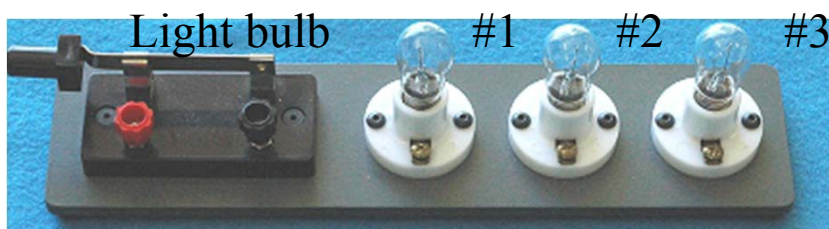

## Performance Assessment 5:

Wire a simple circuit

# Wire a simple circuit

Safety Prompt: Remember to practice safety while engaged in this activity.

# Required Materials

**Light bulb  
circuit-board**

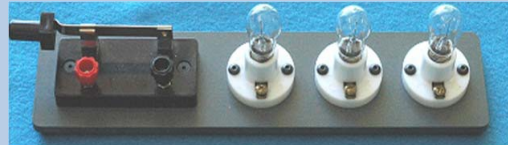

- Hook-up wire
- 1 Red
- 1 Black
- 1 Blue



**Power supply**



**Small flat-head  
screwdriver**



# Step 1

First, attach the tinned end of the red hook-up wire to the positive 12VDC terminal on the power supply. Next, connect the spade (#8) terminal end of the red wire to the red terminal on the knife switch.

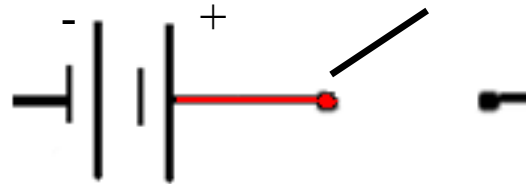

**Note: Tinned End Spade Terminal End**

## Step 2

First, attach spade (#8) terminal end of the blue hook-up wire to the black terminal on knife switch. Next, attach the spade (#6) terminal end to the brass terminal screw on the light bulb.

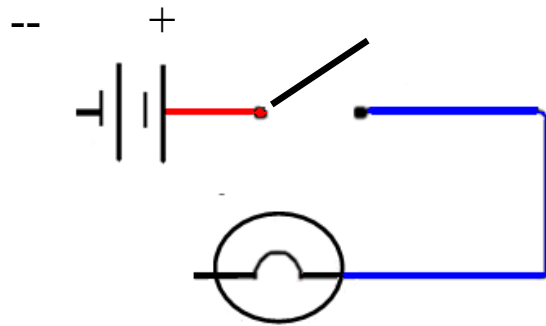

## Step 3

First, attach the black wire's spade (#6) terminal end to the silver terminal screw on the light bulb. Next, attach the tinned end of the black hook-up wire to the negative 12VDC terminal on the power supply.

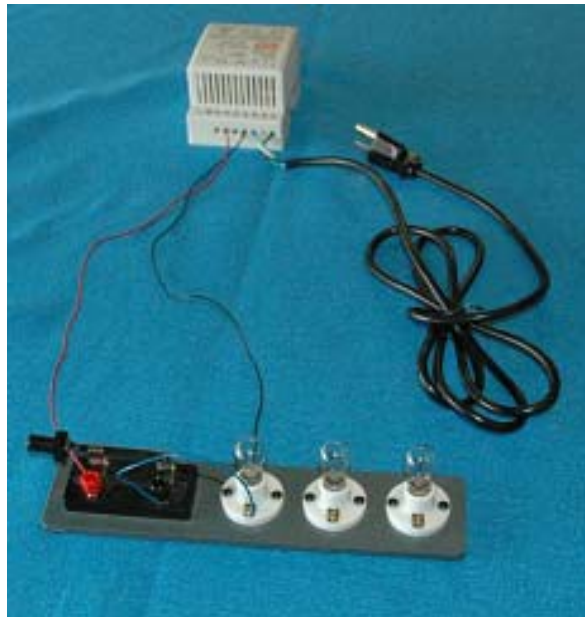
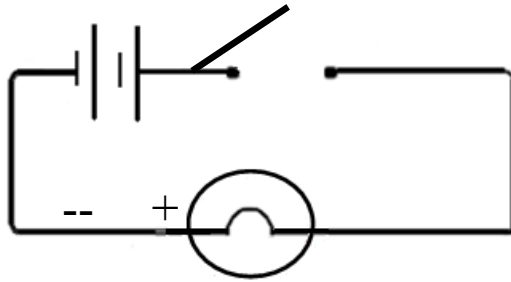

# Step 4

First, complete the self-assessment on the Performance Assessment 5: Wire a Simple Circuit. Next, have your teacher check your wiring.

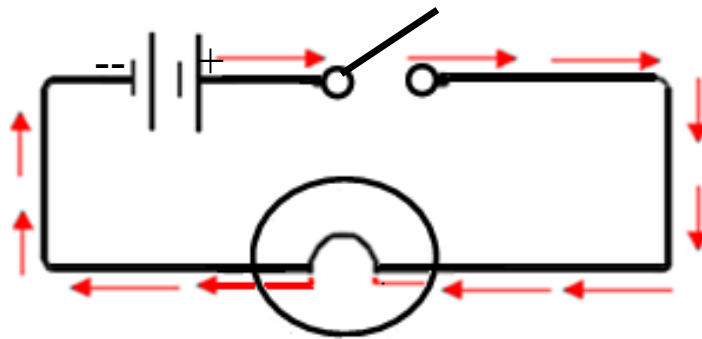



# Step 5

First, plug in the power supply to a 110VAC source and close the knife switch. The light bulb should light. Next, complete the simple circuit section of Activity 5-6-7: #3

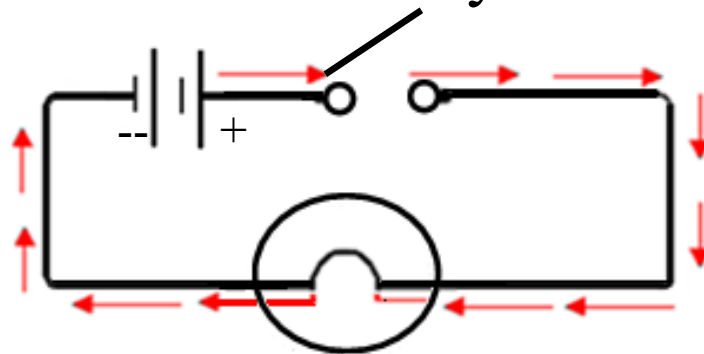

## Performance Assessment 6:

Wire a series circuit

# Wire series circuit

Safety Prompt: Remember to practice safety while engaged in this activity.



# Required Materials

Light bulb circuit-board



Hook-up wire

- 1 Black
- 1 Blue
- 4 White

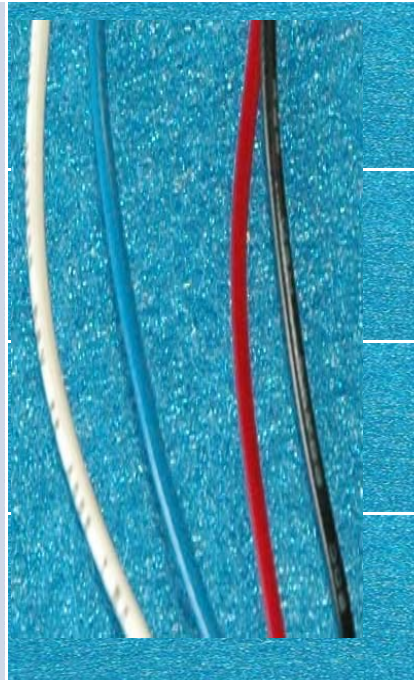

Power supply



Small flat-head screwdriver



# Step 1

First, attach the tinned end of the red hook-up wire to the positive 12VDC terminal on the power supply. Next, attach the spade (#8) terminal end of the red wire to the red terminal on the knife switch.

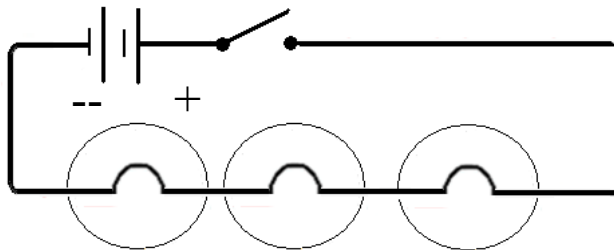

## Step 2

First, attach the spade (#8) terminal end of the blue hook-up wire to the black terminal on knife switch. Next, attach the spade (#6) terminal end to the brass terminal screw on the #1 light bulb.

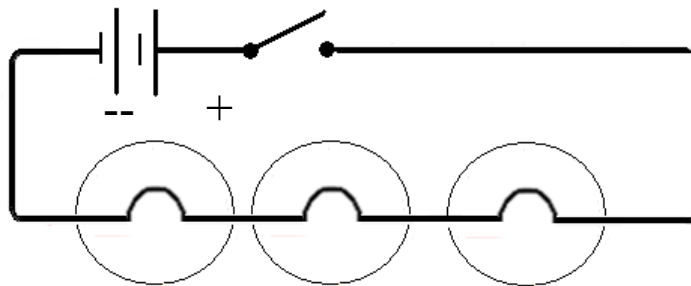

## Step 3

First, attach one of the spade (#6) terminal end of the white hook-up wire to the silver terminal on the #1 light bulb. Next, attach the other end of the wire's spade terminal to the brass terminal on the #2 light bulb.

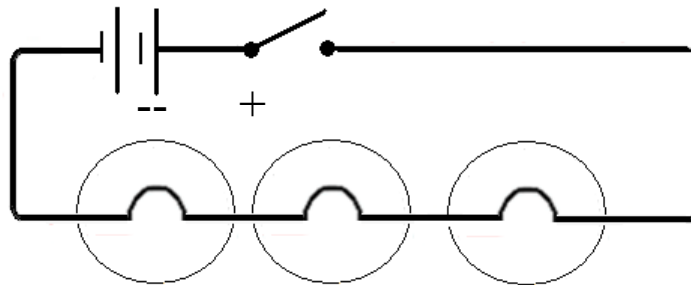

## Step 4

First, attach one of the spade (#6) terminal end of the white hook-up wire to the silver terminal on the #2 light bulb. Next, attach the other end of the wire's terminal to the brass terminal on the #3 light bulb.

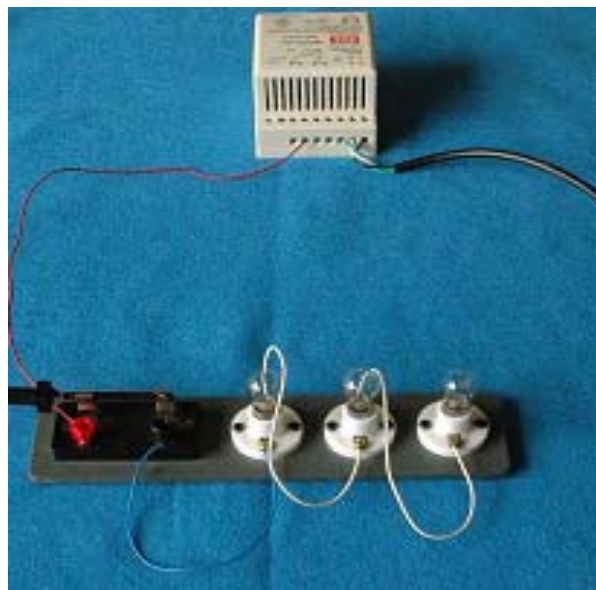
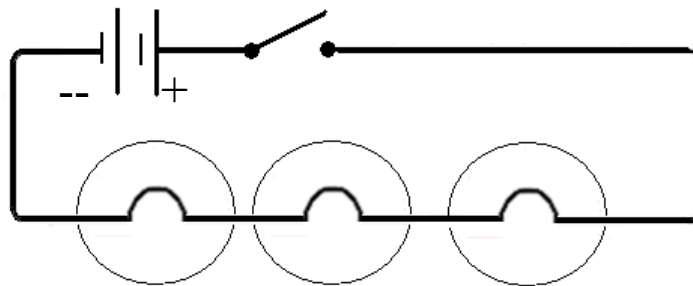



# Step 5

First, attach the black wire's spade (#6) terminal end to the silver terminal screw on the light bulb. Next, attach the tinned end of the black hook-up wire to the negative 12VDC terminal on the power supply.

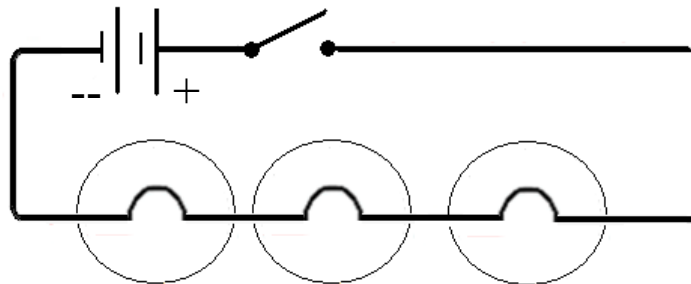

# Step 6

First, plug in the power supply to a 110VAC source and close the knife switch. The light bulb should light. Next, complete the series circuit section of Activity 5-6-7: # 3

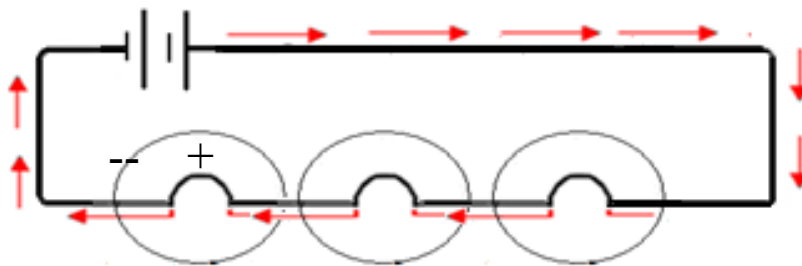

## Performance Assessment 7:

Wire a parallel circuit

# Wirea parallel circuit

Safety Prompt: Remember to practice safety while engaged in this activity.



# Materials Needed

**Light bulb  
circuit-board**



Hook-up wire

- 1 Black
- 1 Blue
- 4 White



Power supply



Small flat-  
head  
screwdriver



# Step 1

First, attach the tinned end of the red hook-up wire to the positive 12VDC terminal on the power supply. Next, attach the spade (#8) terminal end of the red wire to the red terminal on the knife switch

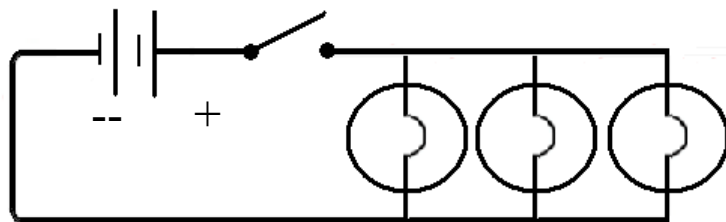

## Step 2

First, connect the spade (#8) terminal end of the blue hook-up wire to the black terminal on knife switch. Next, connect the spade (#6) terminal end to the brass terminal screw on the #1 light bulb.

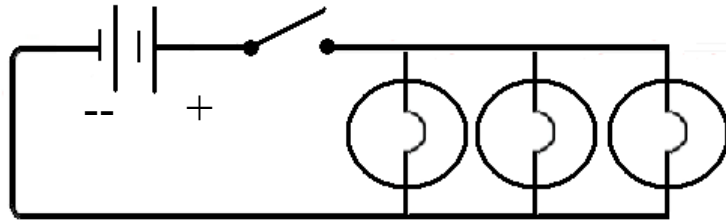

## Step 3

First, attach the spade (#6) terminal end of the white hook-up wire to the brass terminal on the #1 light bulb.

Next, attach the other end to the brass terminal on the #2 light bulb.

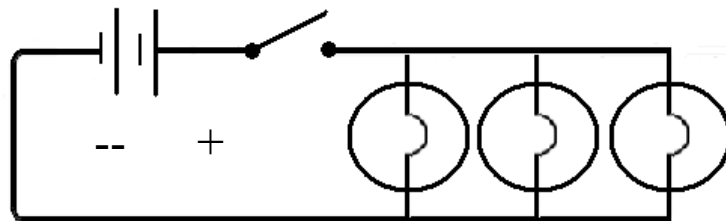



## Step 4

First, attach the spade (#6) terminal end of the white hook-up wire to the brass terminal on the #2 light bulb.

Next, attach the other end to the brass terminal on the #3 light bulb.

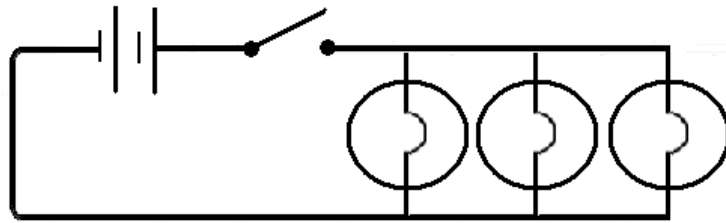

# Step 5

First, attach the small (#6) spade terminal end of the white hook-up wire to the silver terminal on the #3 light bulb. Next, attach the other end to the silver terminal on the #2 light bulb.

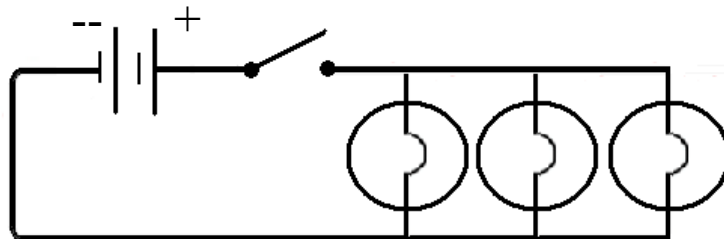

## Step 6

First, attach the small (#6) spade terminal end of the white hook-up wire to the silver terminal on the #2 light bulb. Next, attach the other end to the silver terminal on the #1 light bulb.

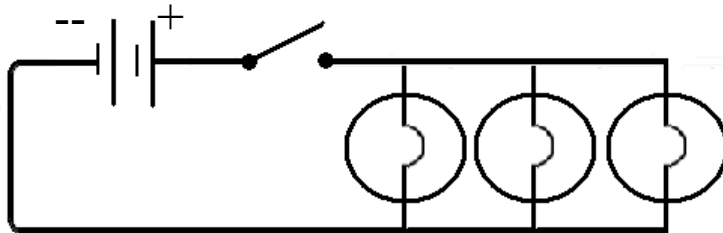

# Step 7

First, attach the black wire's spade (#6) terminal end to the silver terminal screw on the light bulb. Next, attach the tinned end of the black hook-up wire to the negative 12VDC terminal on the power supply.

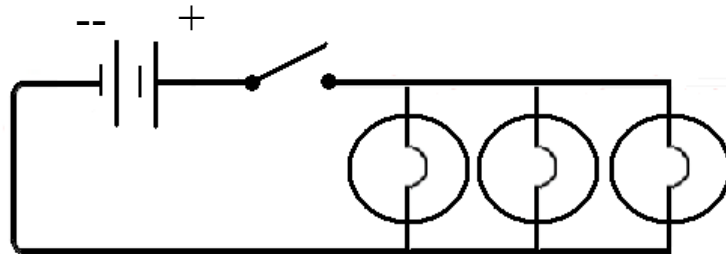

# Step 8

First, plug in the power supply to a 110VAC source and close the knife switch. The light bulb should light. Next, complete the parallel circuit section of Activity 5-6-7: #3

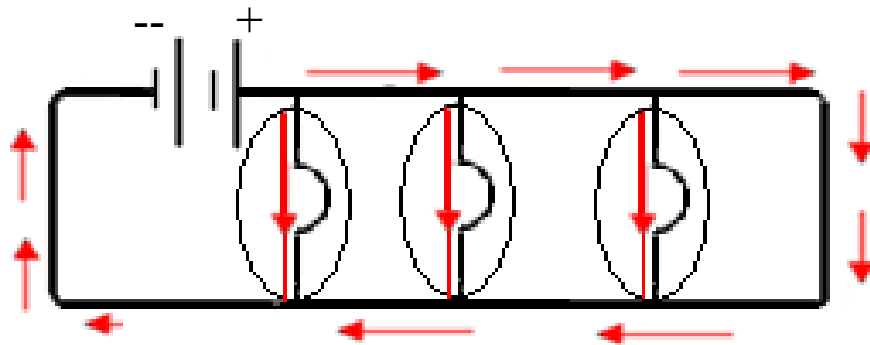

## Performance Assessment 8:

Wire a mechanical relay

# Wire a mechanical relay

Safety Prompt: Remember to practice safety while engaged in this activity.



**Safety**matters

# Materials Needed

Light-bulb circuit-board



Hook-up wire kit



12V Relay



Power supply



Small flat Head  
Screwdriver





# Step 1

First, attach the tinned end of the red hook-up wire to the positive 12VDC terminal on the power supply.

Next, attach the spade (#8) terminal end of the red wire to the red terminal on the knife switch.

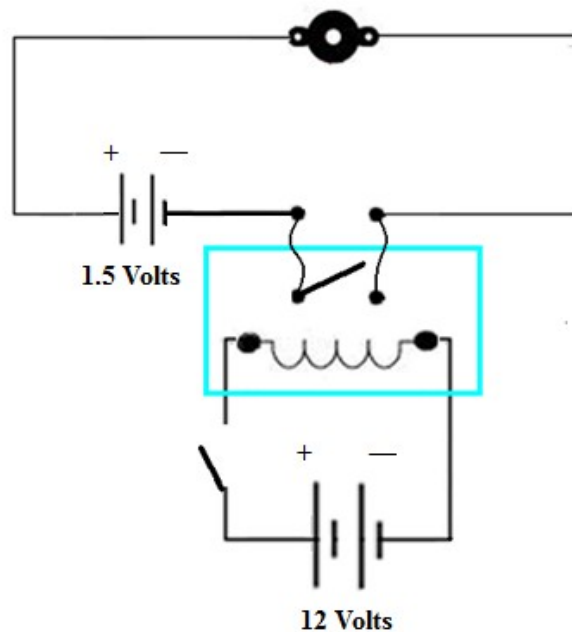

## Step 2

First, attach the red wire from the relay to the black terminal on the knife switch.

Next, attach the black wire from the relay to the negative 12VDC terminal on the power supply.

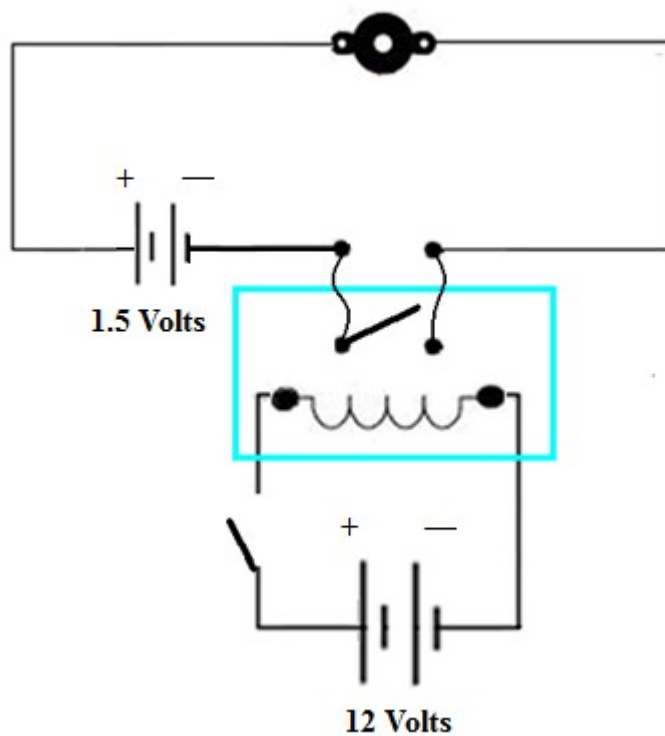

## Step 3

First, attach the blue wire from the relay to the gold terminal on the continuity tester.

Next, connect the white wire from the relay to the other gold terminal on the continuity tester.

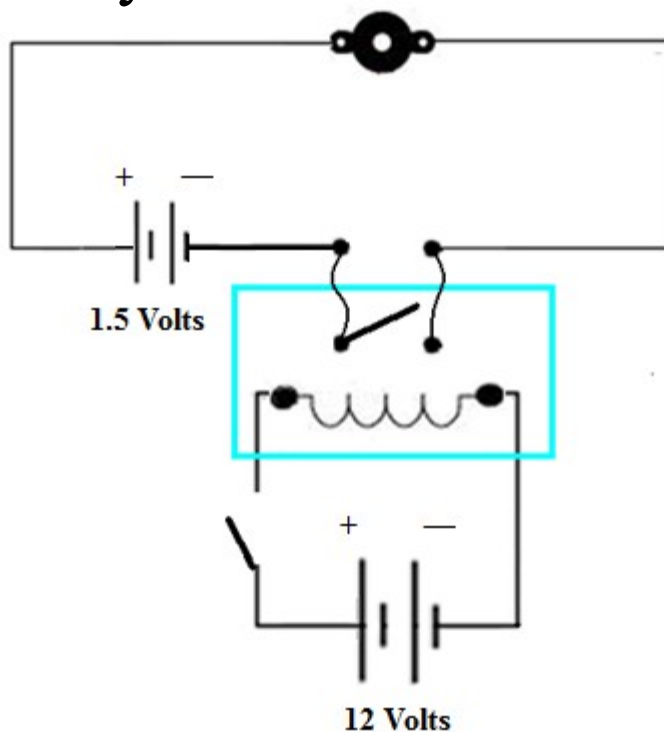

# Step 4

First, plug in the power supply to a 110VAC source and ensure there is a battery in the continuity tester.

Next, close the knife switch. A sound should emit from the buzzer.

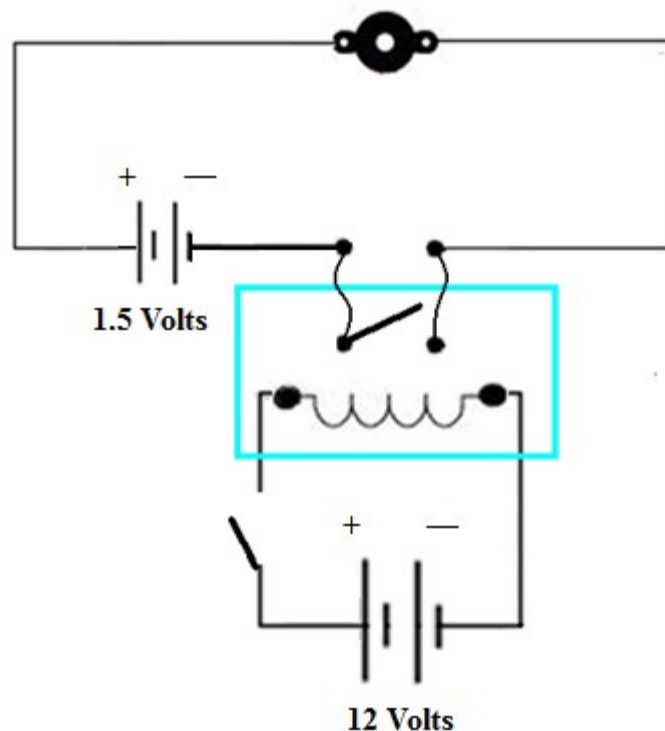

Performance Assessment 9:  
Wire the NXT Circuit to control the  
traffic light

# Wire a NXT Circuit

Safety Prompt: Remember to practice safety while engaged in this activity.



# Materials Needed

**Lego NXT  
Controller**



**Hook-up  
wire kit**



**Relay board**

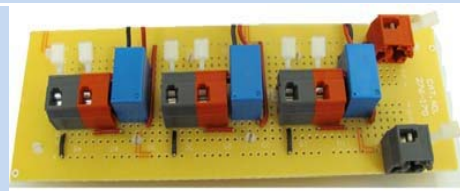

**Power supply**



**Small flat-head  
screwdriver**



**Traffic Light**



## Performance Assessment 9:

Write a program to turn on individual outputs

Our first program will perform the following:

- The green light will turn on for two seconds.
- The green light will turn off.

Wiring:

- The green light is connected to Port A of the NXT controller and relay 1 on the relay board.



# Student Reference Sheet

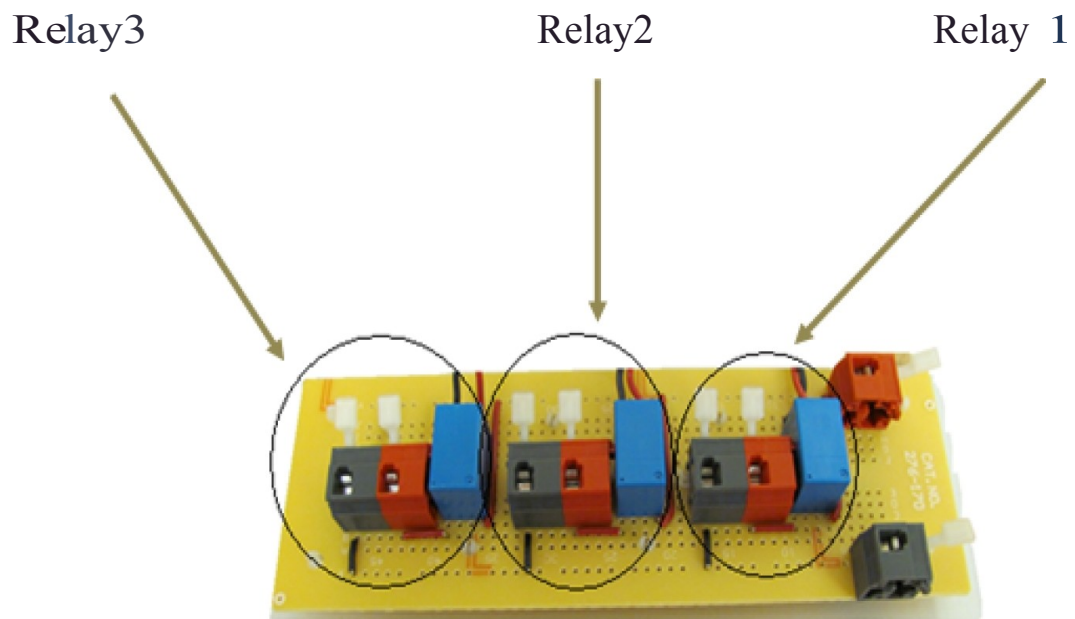

# Step 1

Step 1: Push down on the white handle identified by the red arrow to insert a wire into a post

Step 2: Insert the black-twisted wire into the slot of the post identified by the black arrow.

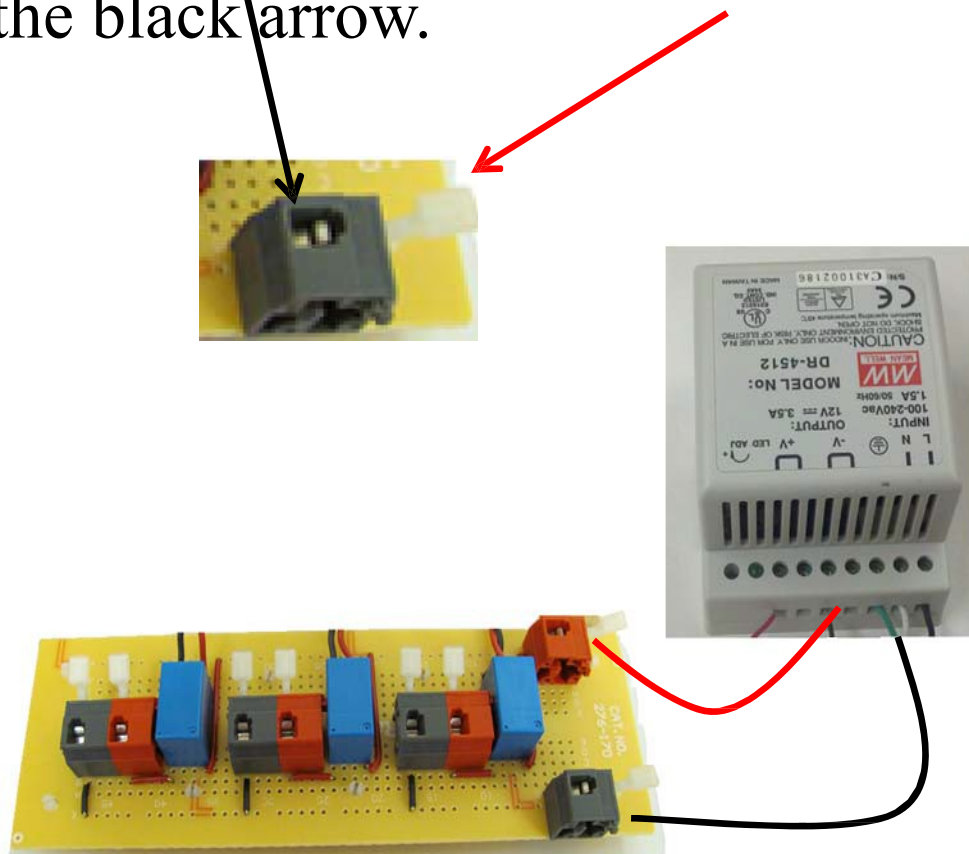

# Step 2

Step 1: Connect the twisted end of the black wire to the negative dark-grey power post on the relay board and connect the tinned end to the negative (-) 12VDC power supply terminal.

Step 2: Connect the twisted end of the red wire to the positive red power post on the relay board and connect the other end to the positive (+) 12VDC power supply terminal.

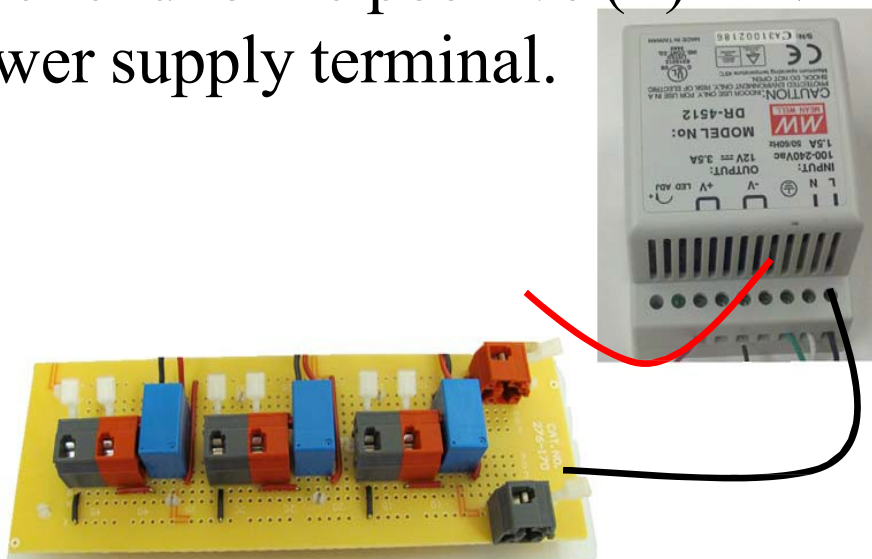

# Step 3

Step 1: Connect the green wire from the traffic light to the red terminal paired with the number one relay terminal.

Step 2: Connect the white wire with a green stripe from the traffic light to the dark grey relay terminal paired with the number one relay.

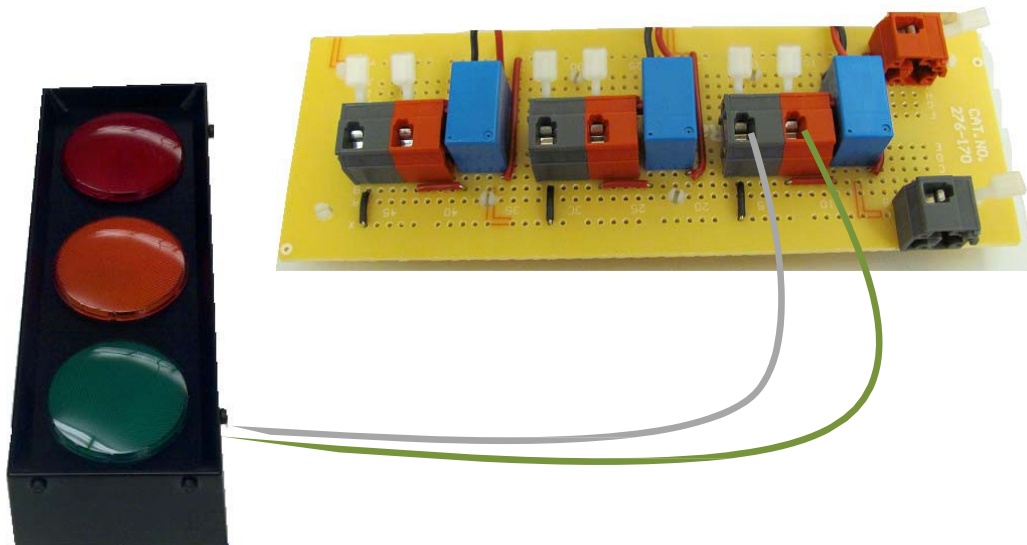

# Step 4

Step 1: Connect line 1 of the relay board to Port A on the NXT Controller

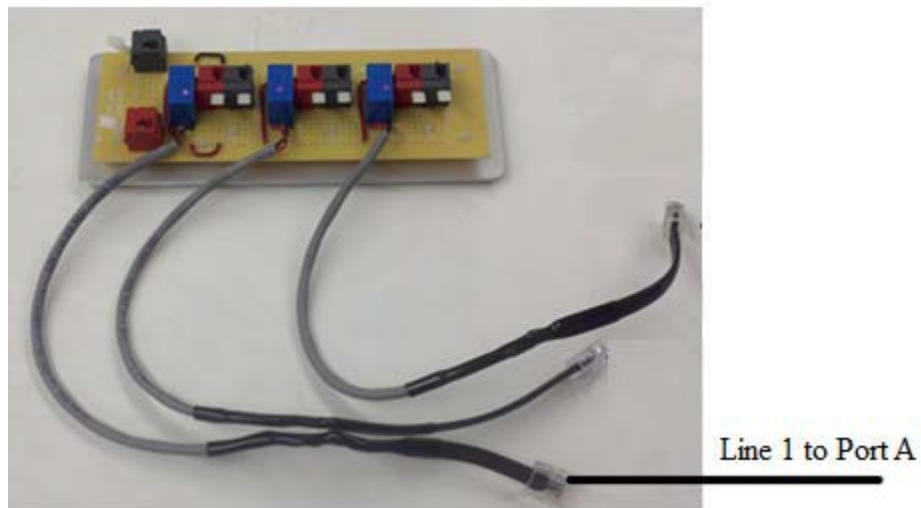

# Step 5

With the A/B USB cable, plug the B end into the NXT Controller and the A end into the computer's USB port.

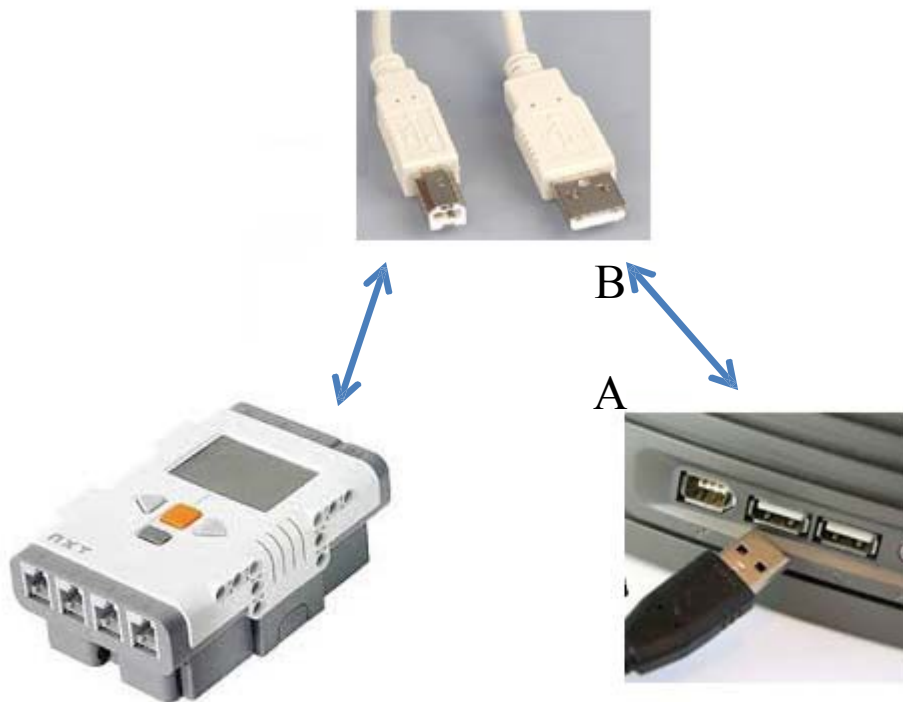

## Step 6

Following the Electrical Controls and Programming Workbook, draw circles around the three various sub circuits.

Next, label the voltages in the sub circuits.

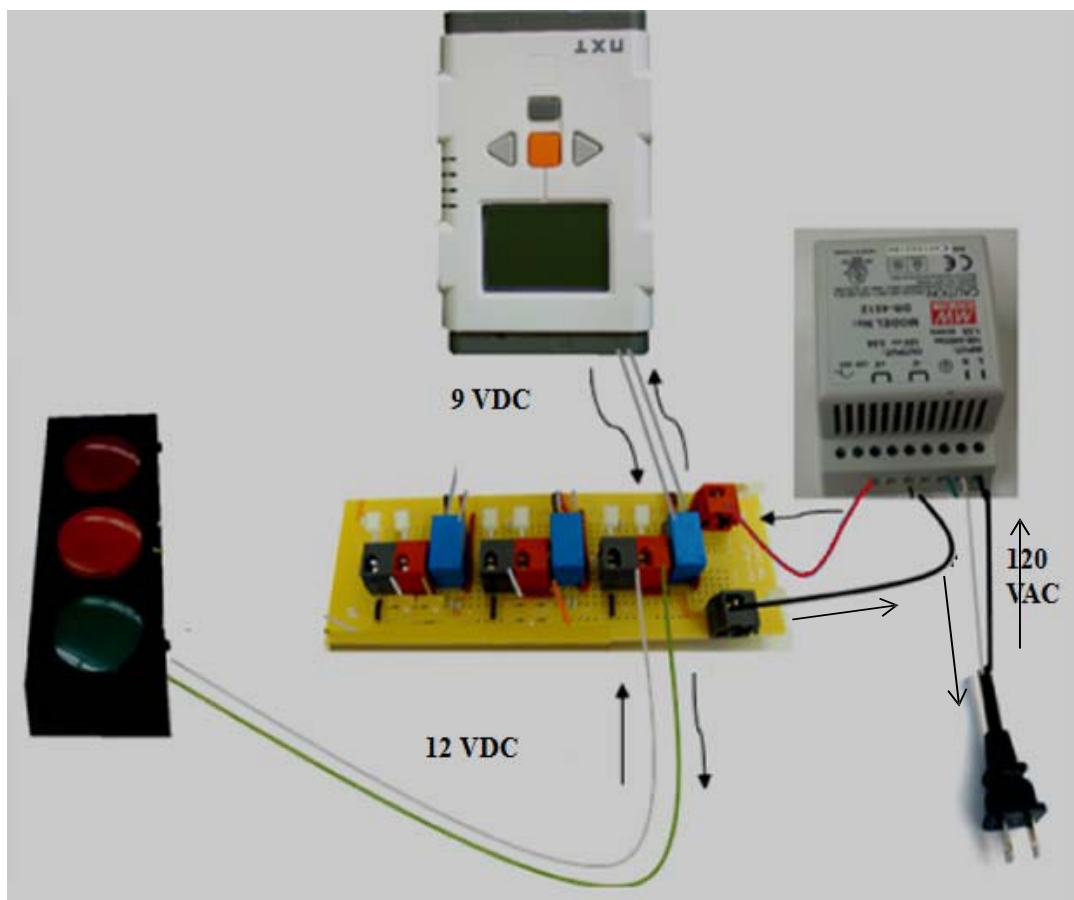

## Performance Assessment 10:

Write a program to turn on individual  
lights  
on a traffic light.



# Programming the Green Light

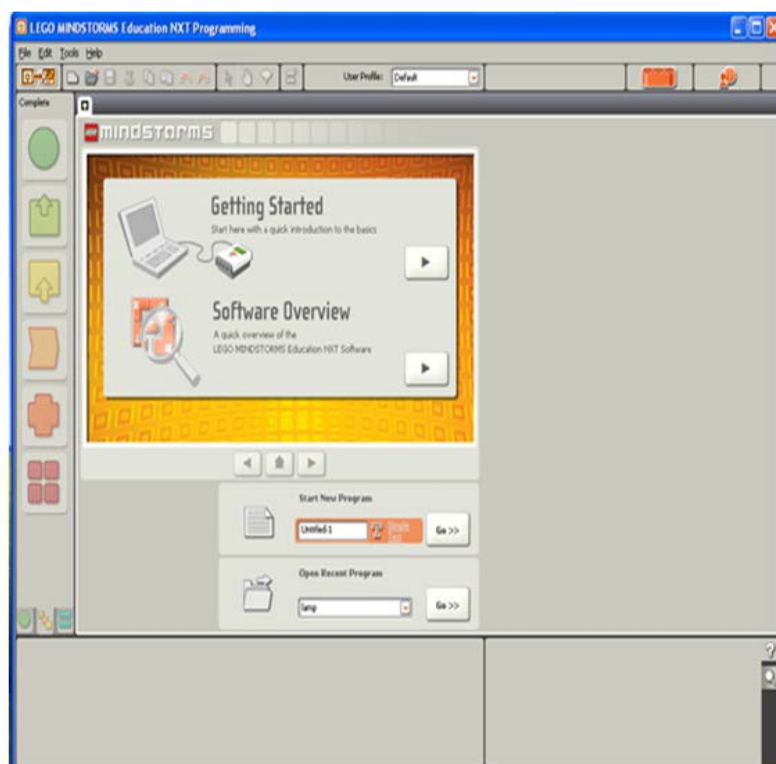

# Step 1

*Objective:* Open the NXT Software

*Procedure:* (Instructor will assist)

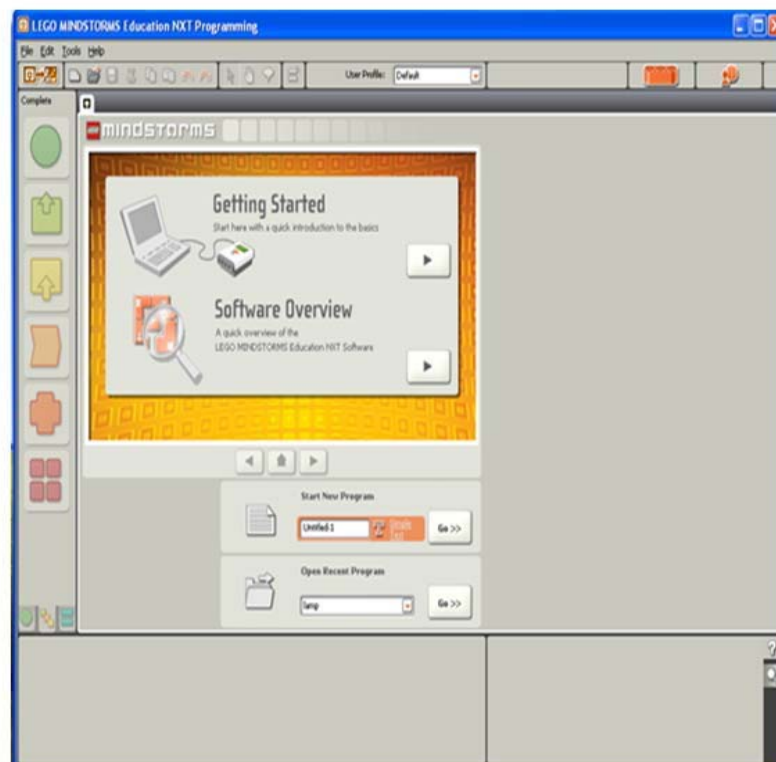

# Step 2

*Objective:* Create a new program

*Procedure:* On the menu, select file, then select **New**

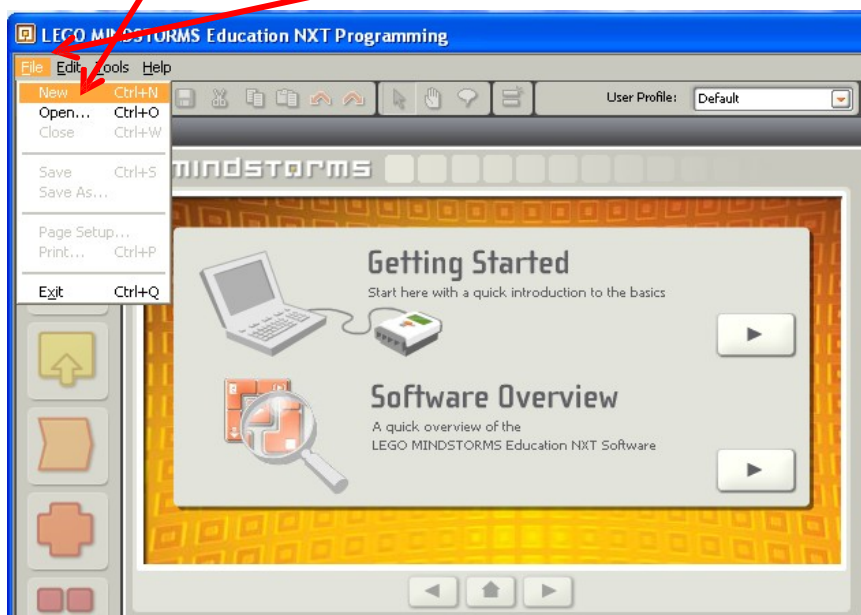

A new program should look like the screen below

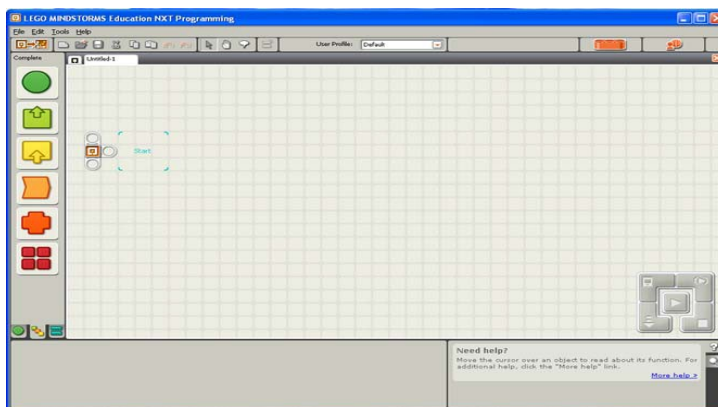

## Step 3

*Objective:* Insert a lamp object

*Procedure:* On the complex panel, click on the green folder with the up arrow. Select the **lamp object** with the mouse and drag the lamp object to the start position of the **Program Chain**.

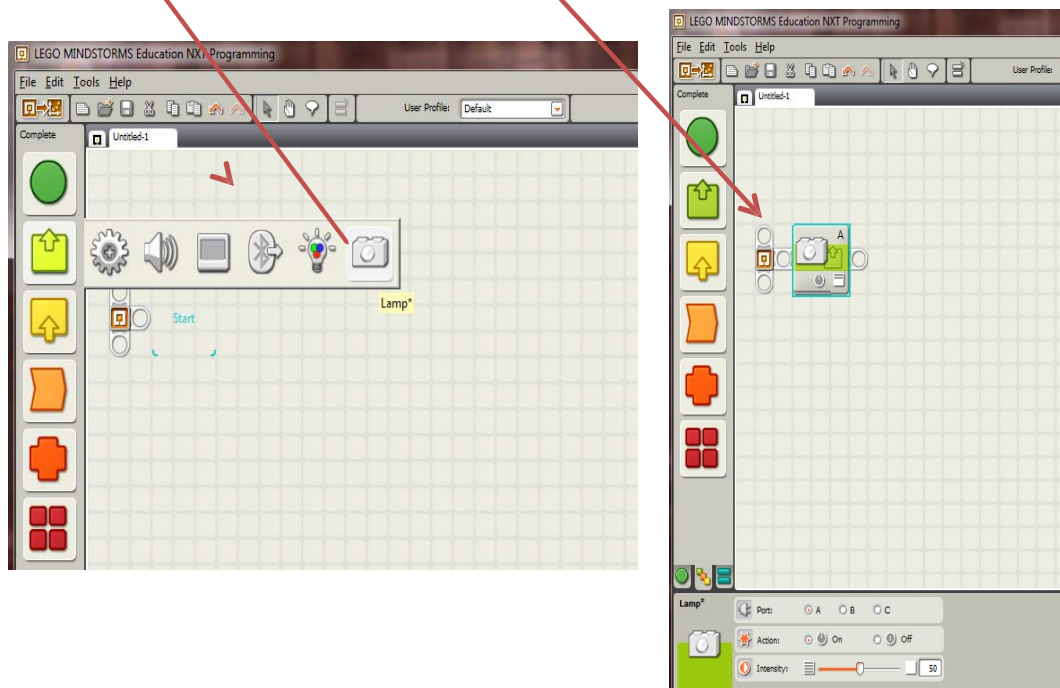

# Step 4

*Objective:* Set the port, action, and intensity of the of the lamp object

*Procedure:* First, set Port to A.  
Next, set Action to **On**.  
Finally, adjust Intensity to **100**

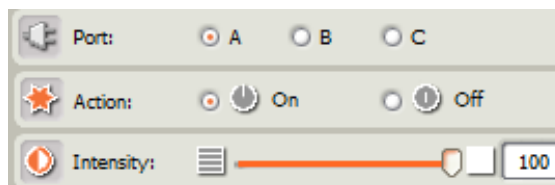

# Step 5

*Objective:* Insert a Wait object

*Procedure:* On the complex panel, click on the green circle. Select the **Wait** object with the mouse and drag the Wait object to the right of the lamp object on the **Program Chain**.

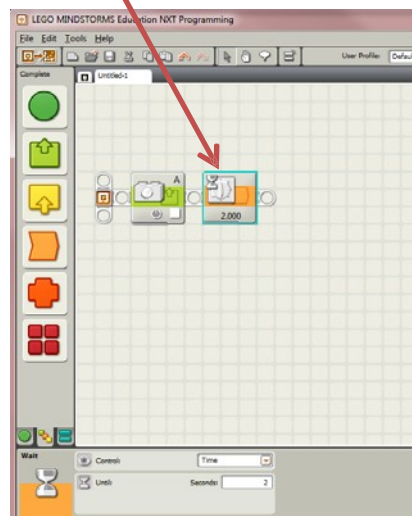
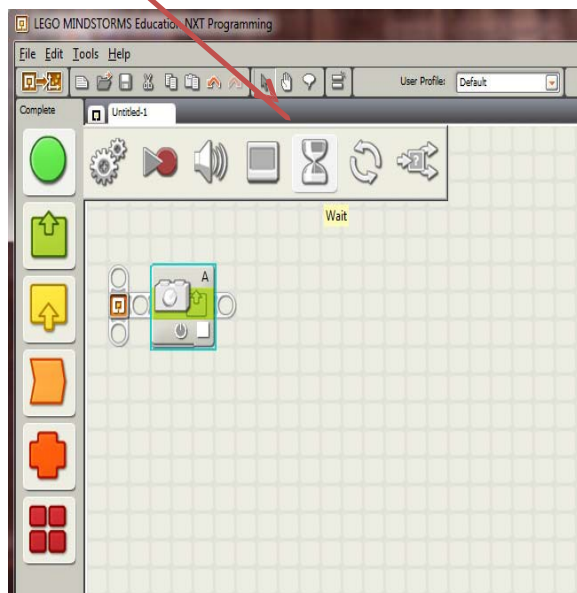

# Step 6

*Objective:* Set the Control and Until properties of the Wait object

*Procedure:* Set Control to **Time** and set **Until** to 2 seconds.

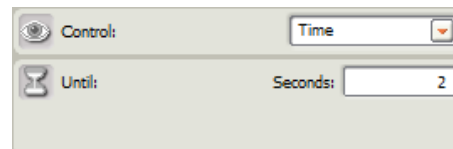
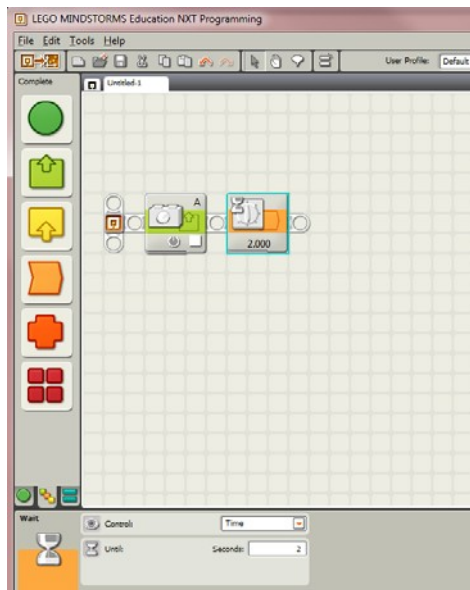

# Step 7

*Objective:* Add the Lamp object

*Procedure:* On the complex panel, click on the green folder with the up arrow. Select the **Lamp** object with the mouse and drag the lamp object to the right of the wait object. Next, set the Control to **OFF**. Port should be set to A.

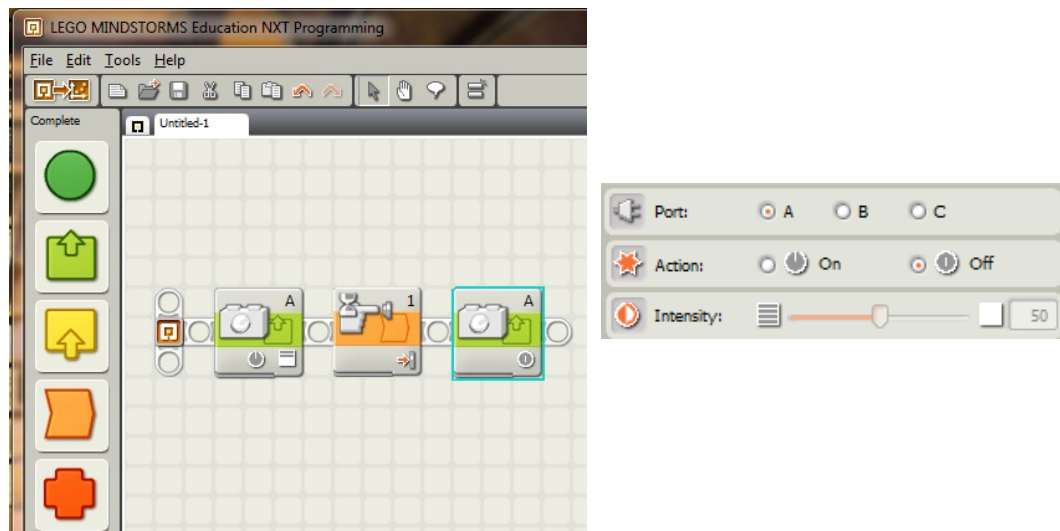



# Step 8

*Objective:* Execute the program and let the fun begin

*Procedure:* Power on the NXT and click on the arrow button located at the bottom right of the screen.

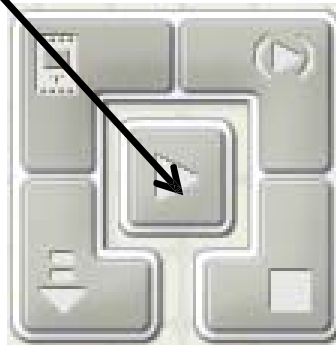

# It's time to demonstrate your skills

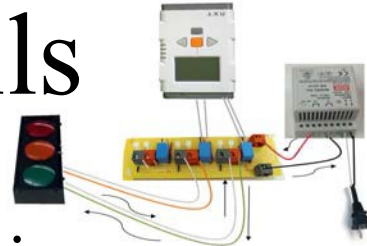

Perform the following:

- Wire an NXT circuit to control the yellow traffic light using Port B and relay 2.
- Complete the wiring section for the yellow light activity sheet 9.
- Draw arrows to represent the electrical flow in activity sheet 9 for the yellow light.

- Write a program to turn on the yellow light for 3 seconds.
- Demonstrate your skills to the instructor. And have your instructor check-off the performance assessment.

# It's time to demonstrate your skills



Perform the following:

- Wire an NXT circuit to control the yellow traffic light using Port C and relay 3.
- Complete the wiring section for the red light activity sheet 9.
- Complete the electrical flow in activity sheet 9 for the red light.

- Write a program to turn on the red light for 3 seconds.
- Demonstrate your skills to the instructor. And have your instructor check off the performance assessment.

## Performance Assessment 11:

Write a program to  
control a traffic light

Write a program to  
control outputs  
on a traffic light.

Safety Prompt: Remember to  
practice safety while engaged in  
this activity.



**Safety**matters

# Step 1

*Objective:* Write a program to control outputs on a traffic light

*Procedure:* Place two lamp objects on the program chain. Next, set the first Lamp Object's properties to Port A and Intensity to 100. Set the second Lamp Object's properties to Port C and Intensity to 100.





## Step 2

*Objective:* Write a program to control outputs on a traffic light

*Procedure:* Place the Wait Object to the right of the Lamp Objects on the program chain. Next, set the Lamp Object's properties to Time and set the seconds to 2.



# Step 3

*Objective:* Write a program to control outputs on a traffic light

*Procedure:* Place two Lamp Objects on the program chain.  
Next, set the first Lamp Object's properties to Port A and OFF. Set the second Lamp Object's properties to Port C and OFF.



# Step 4

*Objective:* Write a program to control outputs on a traffic light

*Procedure:* Place two Lamp Objects on the Program Chain.

Next, set the first Lamp Object's properties to Port A and Intensity to 100. Set the second Lamp Object's properties to Port B and Intensity to 100.



# Step 5

*Objective:* Write a program to control outputs on a traffic light

*Procedure:* Place the Wait Object to the right of the Lamp Objects on the Program Chain. Next, set the Lamp Object's properties to Time and set the seconds to 1.



# Step 6

*Objective:* Write a program to control outputs on a traffic light

*Procedure:* Place two Lamp Objects on the Program Chain.  
Next, set the first Lamp Object's properties to Port A and OFF. Set the second Lamp Object's properties to Port B and OFF.



# Step 7

*Objective:* While Loop

*Explanation:* In the real world systems run continually. The way that we can run the program continuously is to use the Loop Object. This object will allow our program to run for infinity.



# Step 8

*Objective:* Write a program to control outputs on a traffic light

*Procedure:* Place two Lamp Objects on the program chain.  
Next, set the first Lamp Object's properties to Port A and OFF. Set the second Lamp Object's properties to Port B and OFF.



# Step 9

**Objective:** Place objects in the loop

**Procedure:** Use your mouse to drag all the objects inside the loop on the programming chain while keeping the objects in the same order.

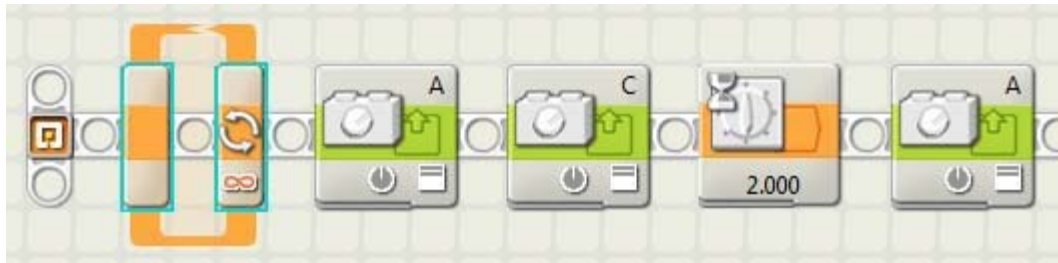



# Step 10

**Objective:** Execute the program

**Procedure:** Make sure your NXT unit is powered on and your relay circuit board has power. Next, execute the program. When you are complete your program should look like the one pictured below. After demonstrating success, have your instructor check the operation of your program.



Performance Assessment 12:  
Write a program to control a  
traffic light based on the input of a  
switch

# Write a program to control a traffic light based on the input of a switch

Safety Prompt: Remember to practice safety while engaged in this activity.



**Safety**matters

# Materials Needed

NXT Circuit

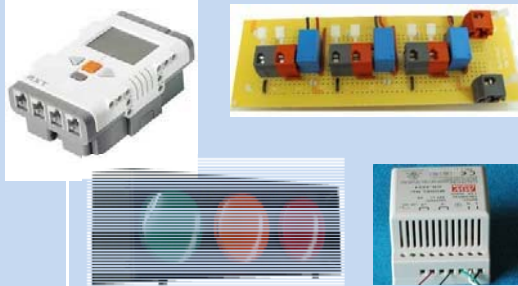

NXT Software

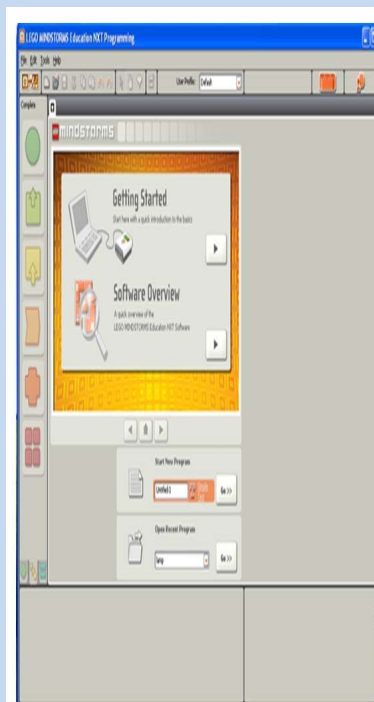

Touch Sensor



# Step 1

*Objective:* Plug in the Push Button Sensor.

*Procedure:* Plug the Push Button Sensor into input Port 1 on the NXT.



# Step 2

*Objective:* Create a new program.

*Procedure:* On the menu, select File, then select **New**.

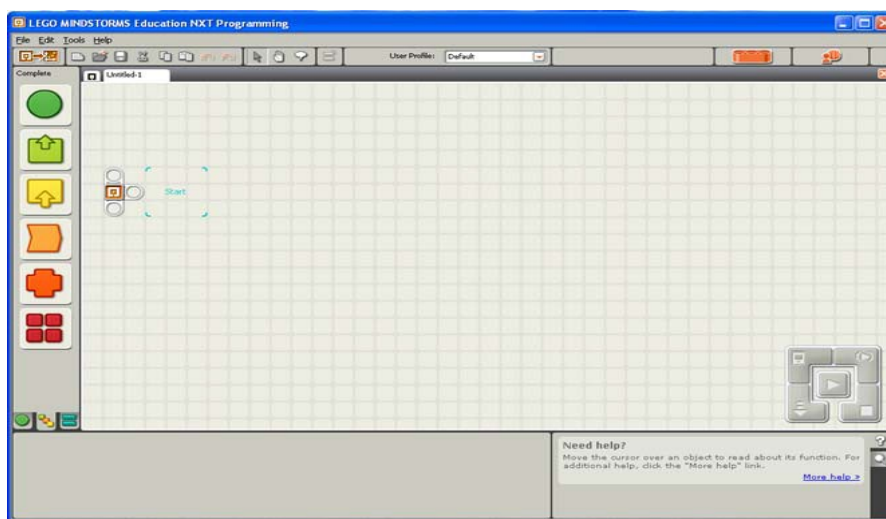
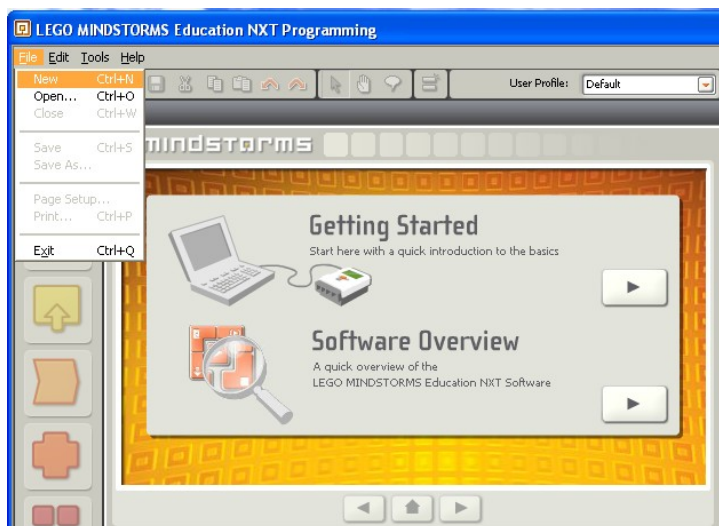

# Step 3

*Objective:* Insert a loop

*Procedure:* Add a loop to the program track.

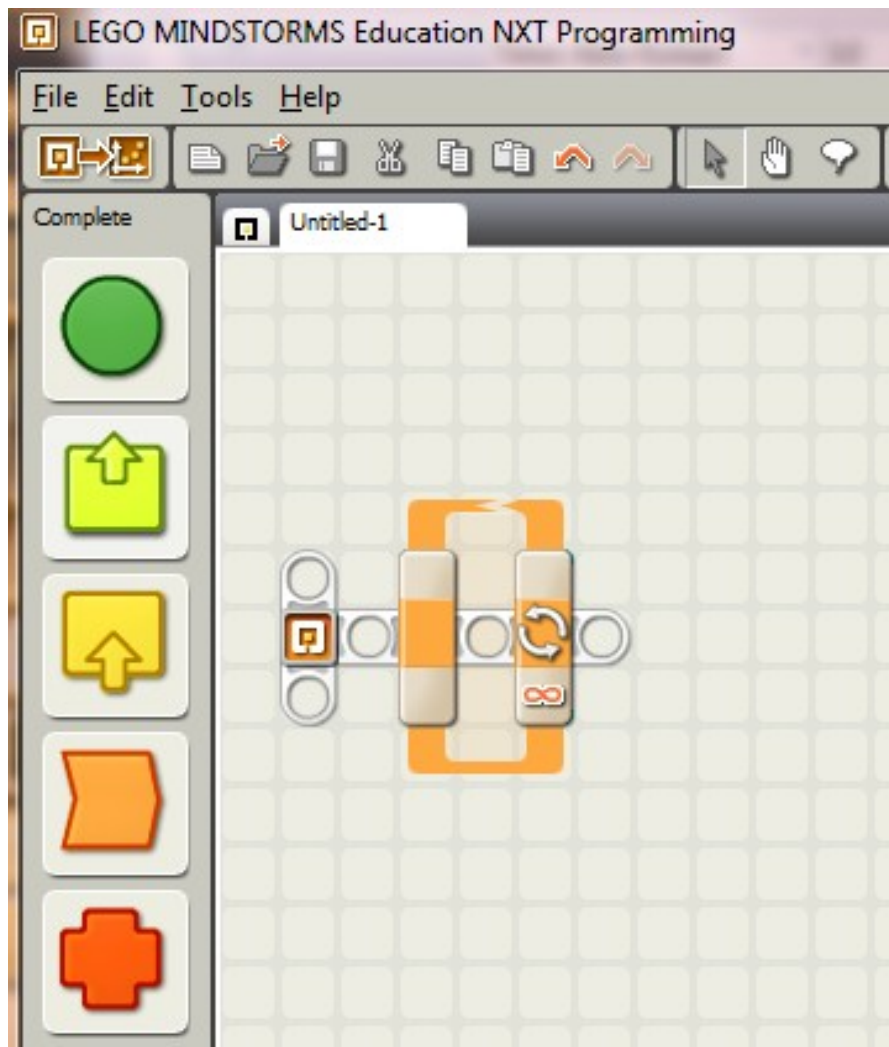

# Step 4

**Objective:** Insert a Switch

**Procedure:** On the Complex Panel, click on the green circle. Then select the Switch Object with the mouse and drag the Switch Object inside the loop on the program chain.

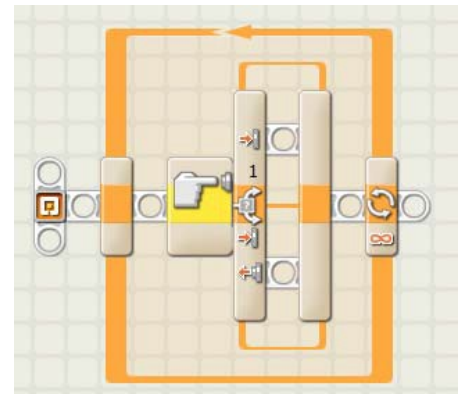
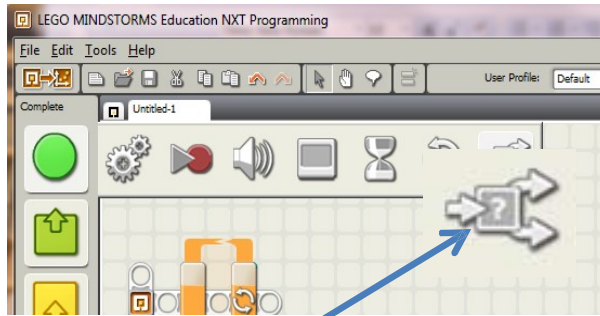



# Step 5

*Objective:* Set the Controls, Sensor, and Action for the Touch Sensor

*Procedure:* Set Controls to Sensor and set Sensor to Touch Sensor. Finally, set Port to 1.





# Step 7

*Objective:* Flowchart the previous program

*Procedure:* Given below is the complete flowchart that represents controlling a light with the input of a switch.

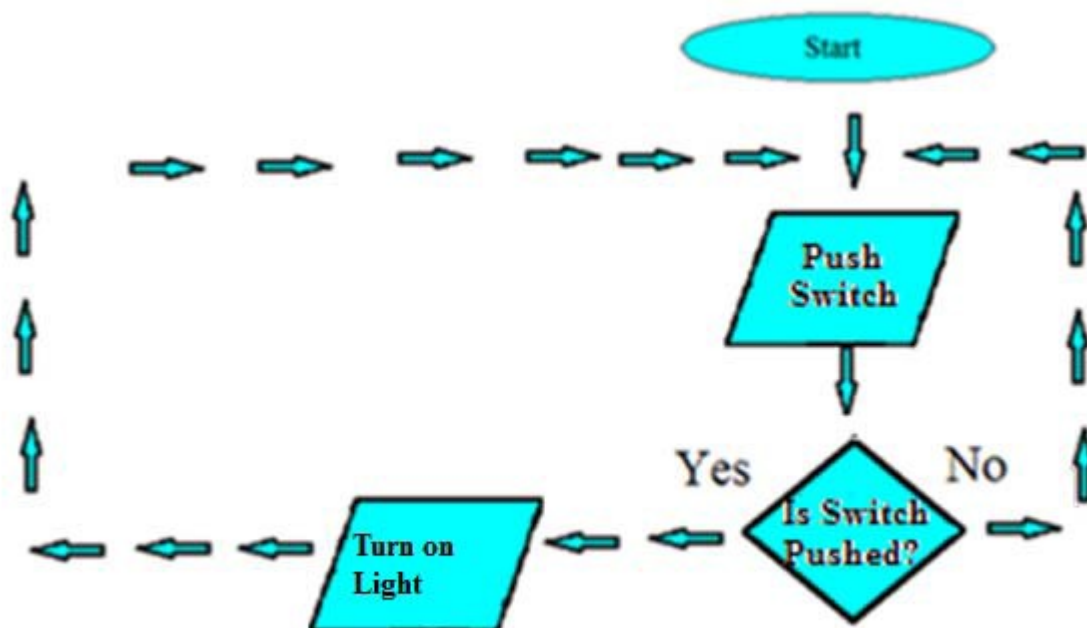

# Step 8

*Objective:* Flowchart the previous program

*Explanation:* Once the program starts, the program checks to see if the Touch Sensor (switch) is pressed.

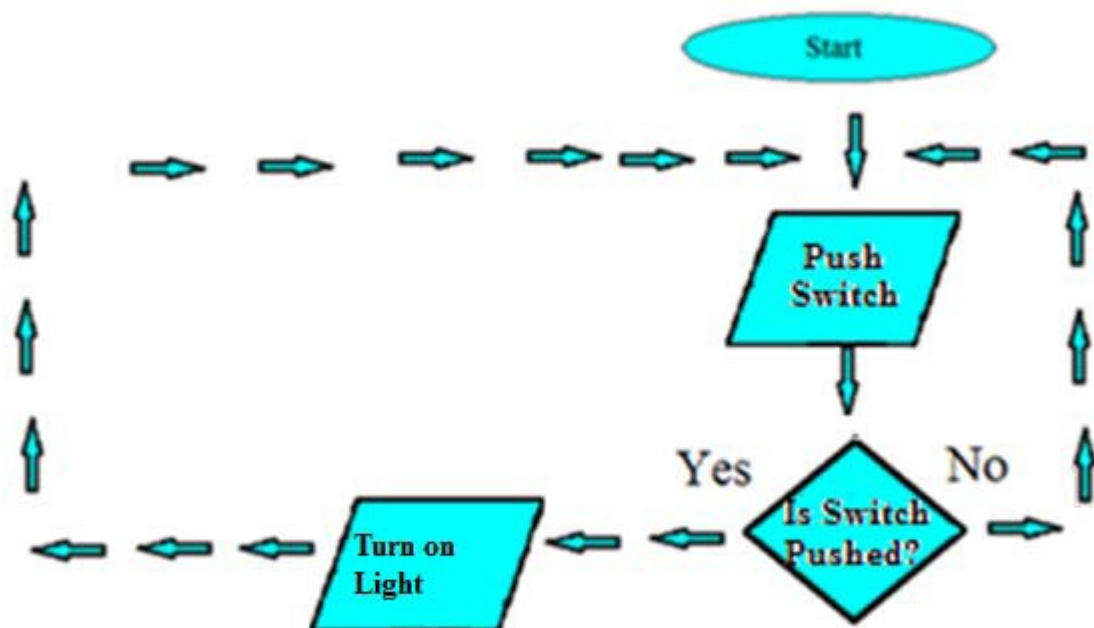

# Step 9

*Objective:* Flowchart the previous program.

*Explanation:* If the switch is pressed, then turn on the light. Then the program checks to see if the Touch Sensor (switch) is still pressed.

*Procedure:* Draw arrows representing the program flow if the switch is pressed.

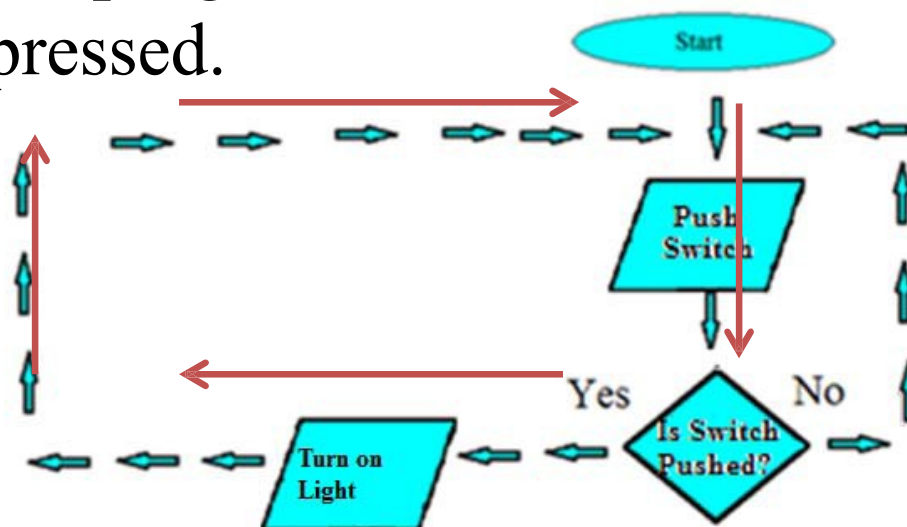

# Step 10

*Objective:* Flowchart the previous program.

*Explanation:* If the switch is not pressed, then the program will check to see if the touch sensor (switch) is still pressed.

*Procedure:* In Activity 11-1, draw arrows representing the program flow if the switch is not pressed.

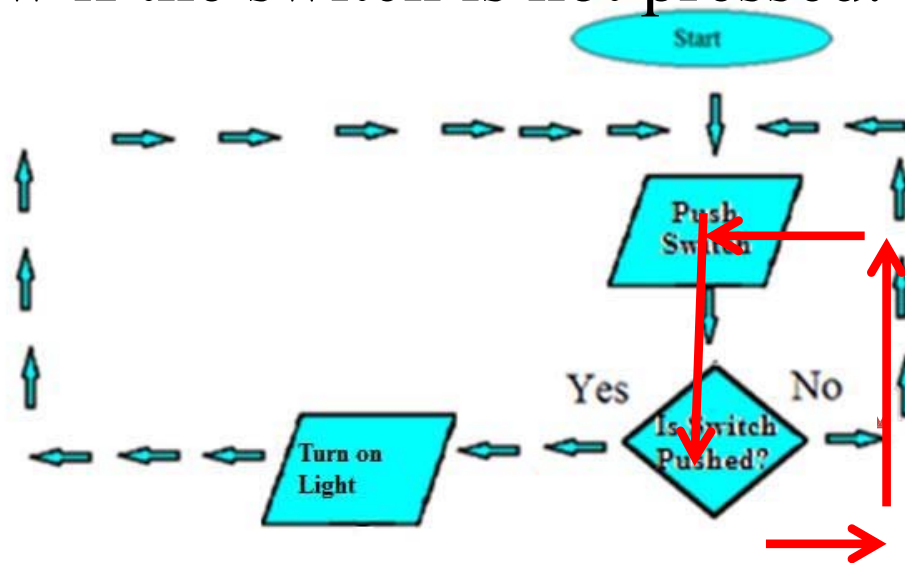

# Step 11

Now that you have completed activity 11-1 have your teacher verify you flowchart and complete activity 11-2 with the Electrical Controls and Programming Workbook.

# Flowchart

*Objective:* Flowchart a Traffic Light

*Procedure:* Using the symbols below, create a flowchart that represents the operation of a traffic light. When the button is pushed, all lights on the traffic light will blink on/off every two seconds. When the button is not pushed, the traffic light will operate under normal conditions.

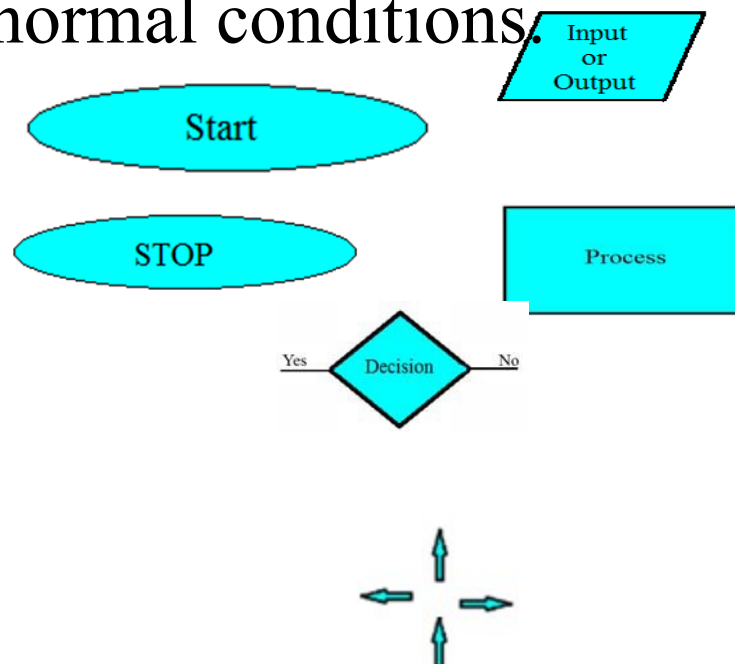



# Step 1

*Objective:* Plug in the Push Button Sensor.

*Procedure:* Plug in the Push Button Sensor into input Port 1 on the NXT.



# Step 2

*Objective:* Create a new program

*Procedure:* On the menu, select file, then select **New**.

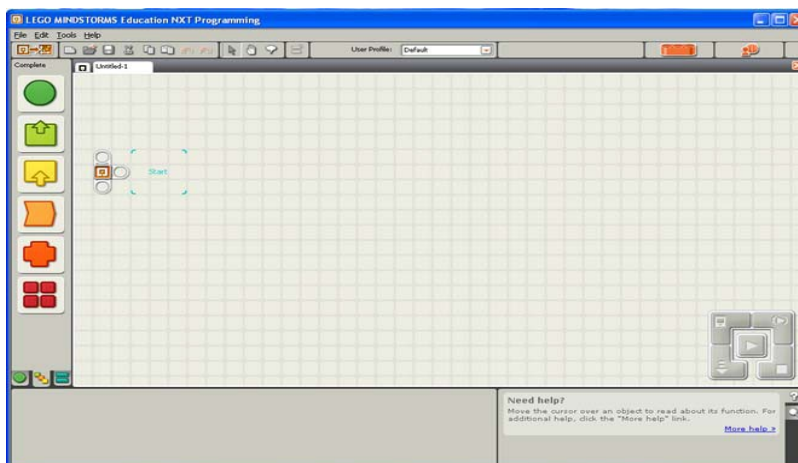
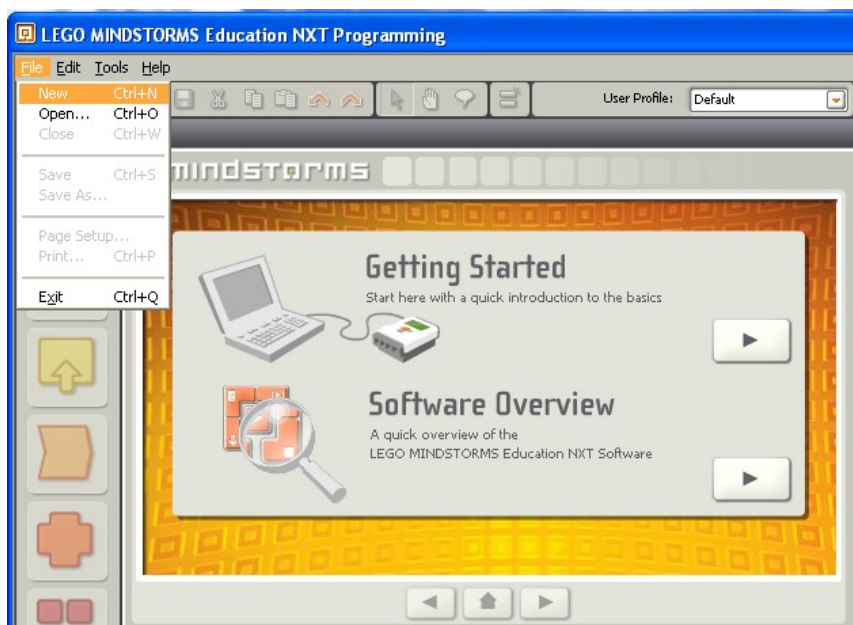

# Step 3

*Objective:* Insert a Loop

*Procedure:* Add a Loop to the Program Chain.

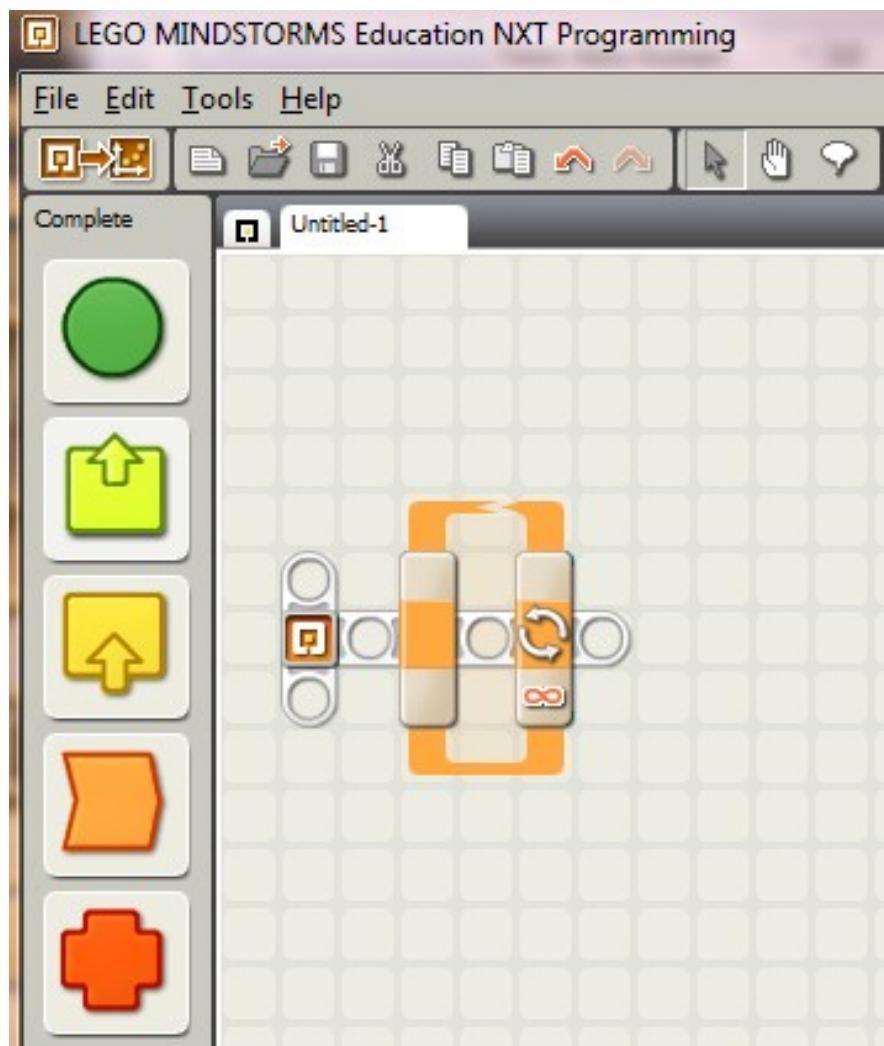

# Step 4

**Objective:** Insert a Switch

**Procedure:** On the Complex Panel, click on the green circle. Then select the Switch Object with the mouse and drag the Switch Object inside the Loop on the Program Chain.

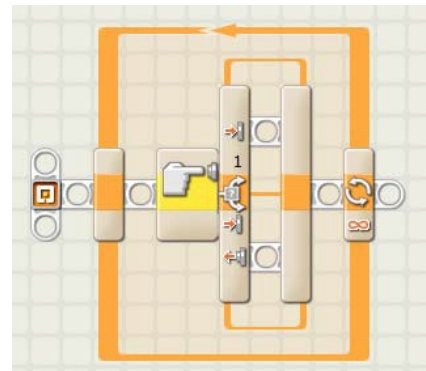
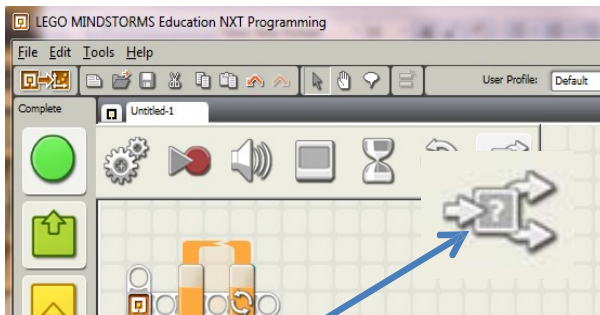

# Step 5

*Objective:* Set the Controls, Sensor, and Action for the Touch Sensor

*Procedure:* Set Controls to Sensor and set Sensor to Touch Sensor. Finally, set Port to 1.





# Step 7

*Objective:* Create your program

*Procedure:* In the bottom Program Chain where the red arrow is pointing inside the Switch Object, write a program to turn on and off all three of the traffic lights at the same time for one second.

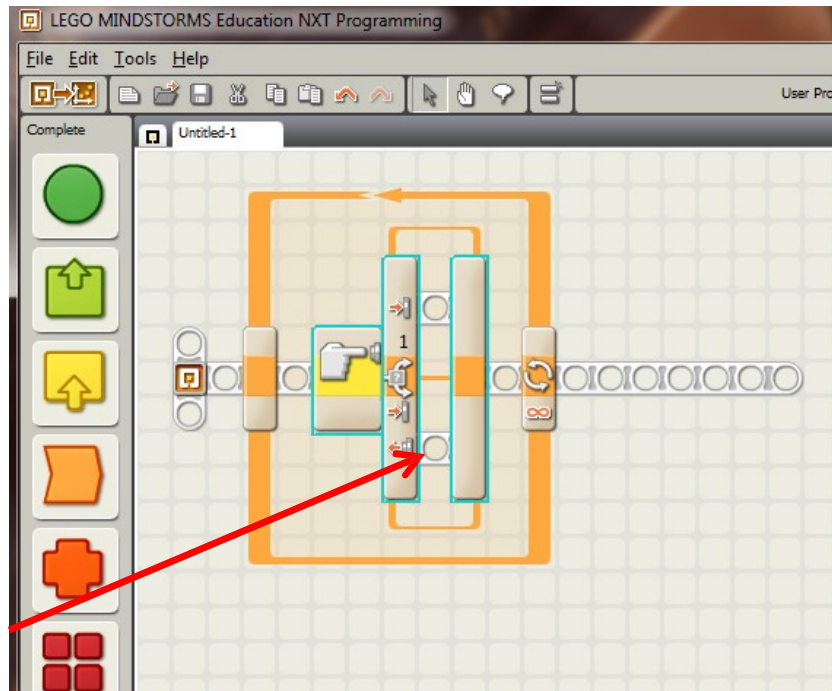

# Step 8

*Objective:* Verification

*Procedure:* Have your teacher verify your program.



Performance Assessment 13:  
Write a program to energize two  
solenoids

# Write a program to energize two solenoids

Safety Prompt: Remember to practice safety while engaged in this activity.



# Materials Needed

Modified NXT  
Circuit



NXT Software

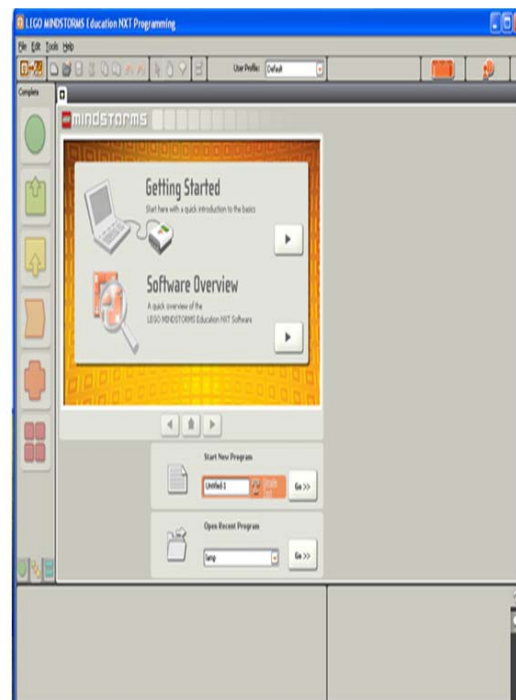

Ping-Pong ball sorter



# Step 1

*Objective:* Modify NXT circuit

*Procedure:* Disconnect the traffic light from relay board.

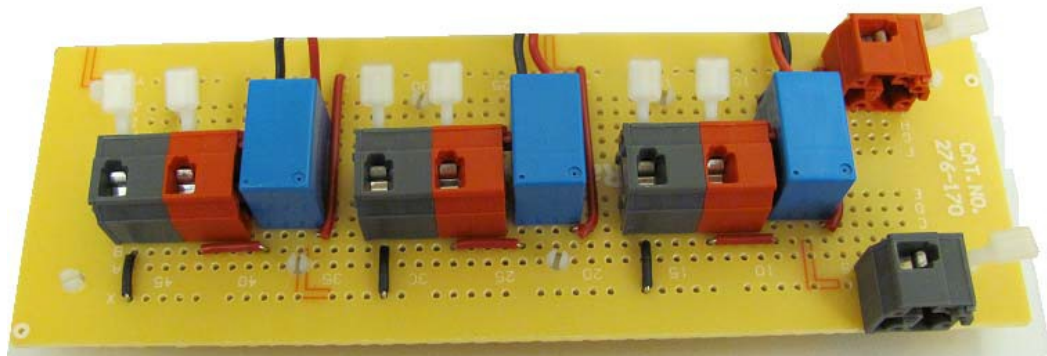

## Step 2

*Objective:* Connect Ping-Pong ball sorter

*Procedure:* Connect the first solenoid to relay one on the relay board.

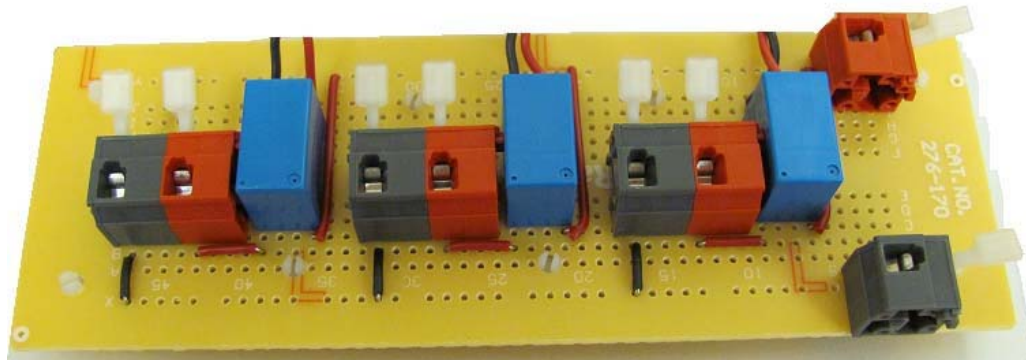

# Step 3

*Objective:* Connect Ping-Pong ball sorter

*Procedure:* Connect the second solenoid to relay two on the relay board.

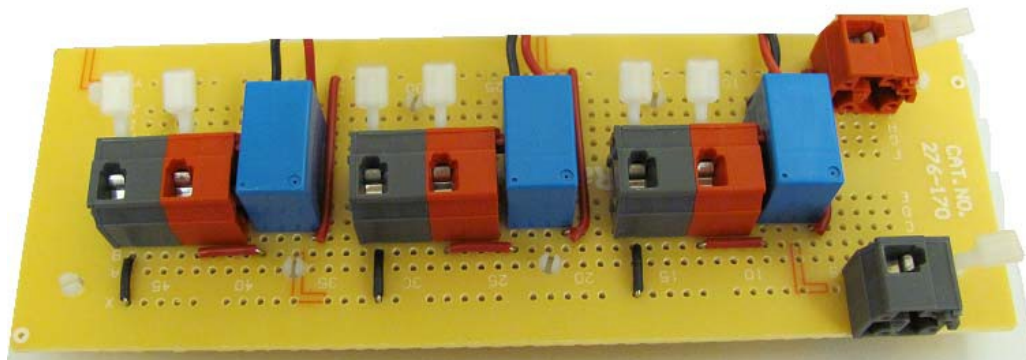

# Step 4

*Objective:* Create a new program

*Procedure:* Open the NXT software. On the Menu, select file, then select **New**.

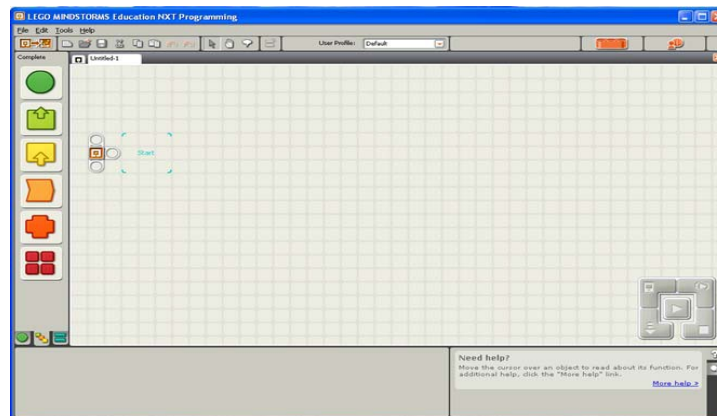
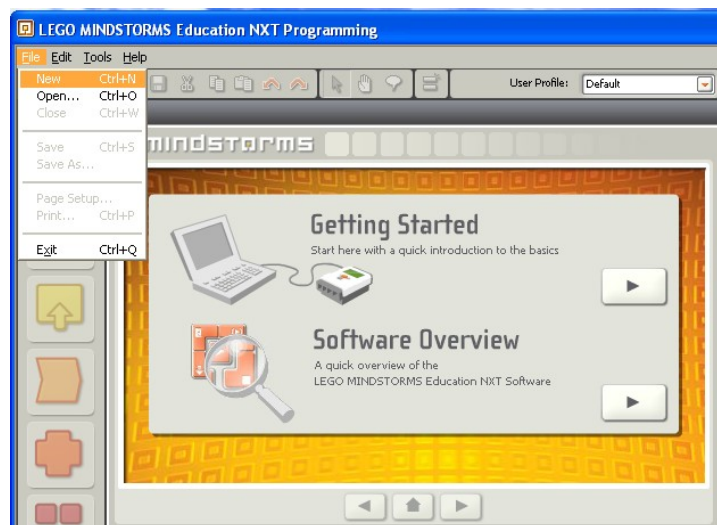

# Step 5

*Objective:* Insert two Lamp Objects and a Wait Object.

*Procedure:* Insert two Lamp Objects on the program chain and set the Ports to **A** and **B**. Next, set the intensity to 100. Finally, insert the Wait object and set the Control to Time and set the Until to 2.

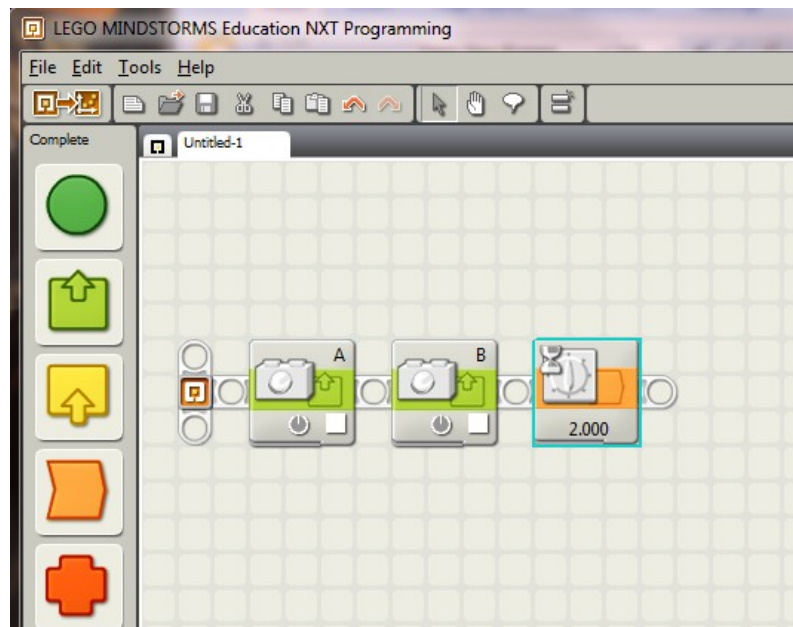



# Step 6

*Objective:* Execute your program

*Procedure:* Push the run button to execute your program.



Performance Assessment 13:  
Write a program to feed Ping-  
Pong balls every two seconds.

Write a program to feed  
Ping-Pong balls every  
two seconds.

Safety Prompt: Remember to  
practice safety while engaged in  
this activity.



**Safety**matters

# Flowchart

*Objective:* Flowchart a Traffic Light

*Procedure:* Using the symbols below, create a flowchart that represents the operation of a ping pong ball feeder that feeds a Ping-Pong ball every two seconds.

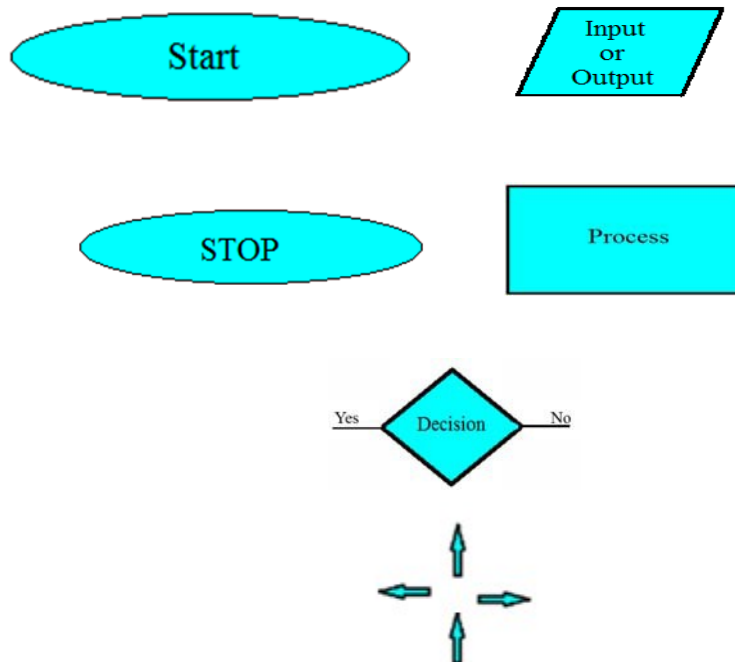

# Materials Needed

## Modified NXT Circuit



## NXT Software



# Step 1

*Objective:* Create a new program

*Procedure:* Open the NXT software. On the Menu, select File, then select **New**.

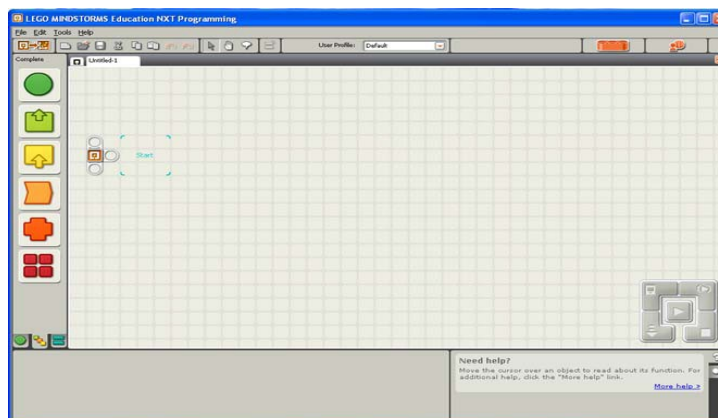
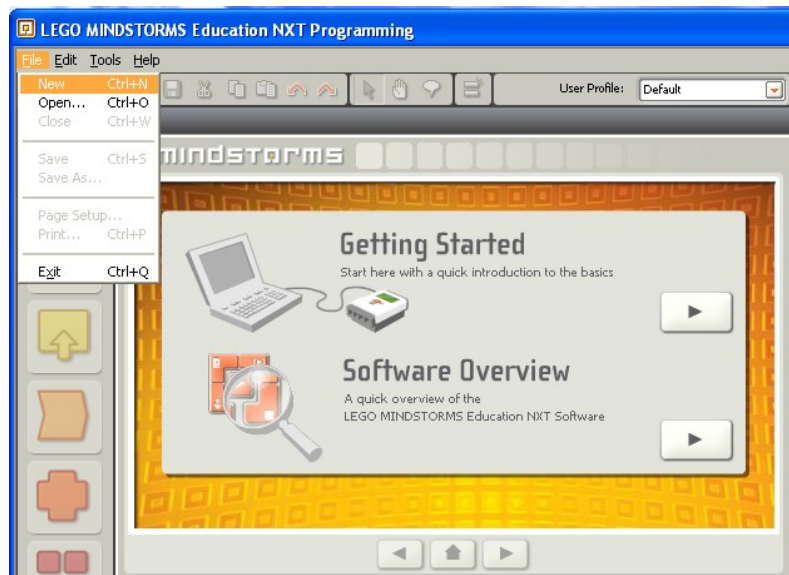

## Step 2

*Objective:* Write a program to control a Ping-Pong ball feeder that will deliver a Ping-Pong ball every two seconds

*Procedure:* Energize solenoid B for two seconds. With a Loop Object, energize solenoid A and de-energize solenoid B for 1 second. Finally, in the same Loop, energize solenoid B and de-energize solenoid A for 1 second.

### Performance Assessment 14:

Write a program to control a Ping-Pong ball feeder based on inputs



Write a program to control a  
Ping-Pong ball feeder  
based on the input of two  
switches.

Safety Prompt: Remember to practice  
safety while engaged in this activity.



# Materials Needed

Modified NXT  
Circuit



NXT Software



2 Touch Sensors



# Flowchart

*Objective:* Flowchart a Traffic Light

*Procedure:* Using the symbols below, create a flowchart that represents the operation of a Ping-Pong ball feeder that is controlled by two buttons.

When no button is pushed, the ping-pong balls are held. When the button in Port A is pushed, the Ping-Pong ball feeder feeds a Ping-Pong ball every two seconds. When the button in Port B is pushed, the Ping-Pong ball feeder feeds a ping pong ball every four seconds.

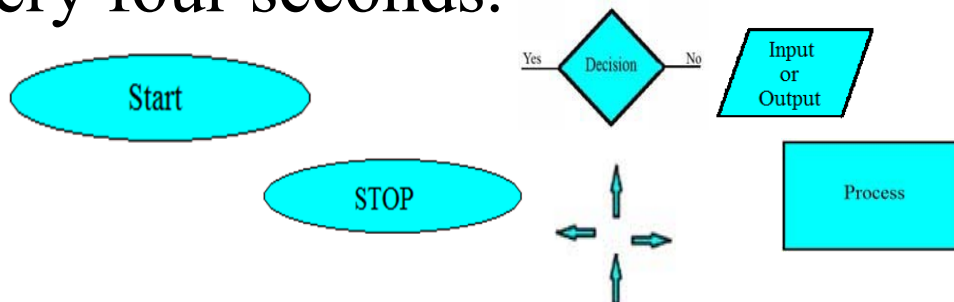

# Step 1

*Objective:* Create a new program

*Procedure:* Open the NXT software. On the Menu, select File, then select **New**.

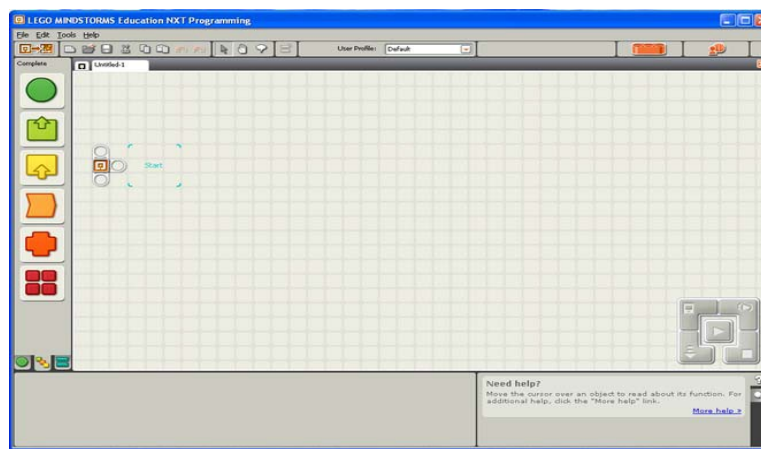
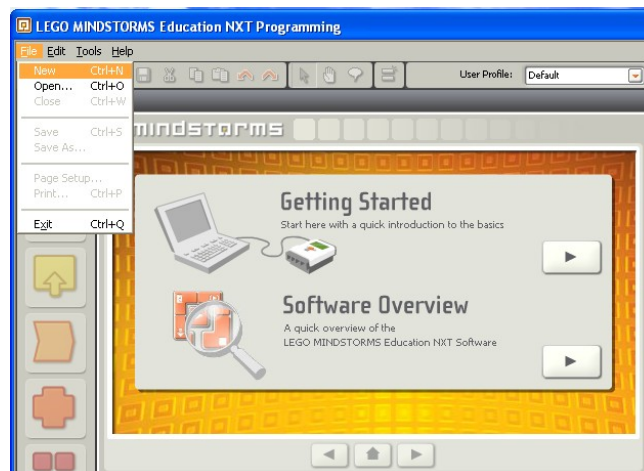

## Step2

*Objective:* Control a Ping-Pong ball feeder with two inputs

*Procedure:* First plug two touch sensors into the NXT Controller. Next, using your flowchart, write a program to control a Ping-Pong ball feeder that will hold all the ping-pong balls until a button is pushed. When button 1 is pushed, the feeder delivers a Ping-Pong ball every two seconds. When button 2 is pushed, the feeder delivers a Ping-Pong ball every 8 seconds.

## Appendix F

Tables for Low and High Groups on the Four Dimensions of Motivation

Table F1

*Movement of Students in the Pretest Low-Treatment Group on the Dimension of Choice*

Student	Pretest group	Science group	Posttest group	Posttest score	Meets movement criteria
16	Low	Low	Low	2.29	
24	Low	Low	Low	2.29	
54	Low	Middle	Low	2.29	
11	Low	Middle	Middle	2.86	X
58	Low	Middle	High	3.86	X
27	Low	Low	High	4.43	

Table F2

*Movement of Students in the Pretest Low-Control Group on the Dimension of Choice*

Student	Pretest group	Science group	Posttest group	Meets movement criteria
37	Low	Low	Low	
94	Low	Low	Low	
53	Low	Middle	Middle	X
42	Low	Low	Middle	
44	Low	Low	Middle	

Table F3

*Movement of Students in the Pretest High-Treatment Group on the Dimension of Choice*

Student	Pretest group	Science group	Posttest group	Meets movement criteria
2	High	Low	Low	X
5	High	Low	Low	X
71	High	Low	Middle	X
77	High	Low	Middle	X
66	High	Middle	Middle	X
23	High	Middle	Middle	X
59	High	Middle	Middle	X
76	High	Middle	Middle	X
17	High	High	Middle	
60	High	High	High	
75	High	High	High	
26	High	High	High	
61	High	High	High	
65	High	High	High	
9	High	High	High	
12	High	High	High	
19	High	High	High	
7	High	High	High	



Table F4

*Movement of Students in the Pretest High-Control Group on the Dimension of Choice*

Student	Pretest group	Pretest score	Science group	Science test score	Posttest group	Meets movement criteria
91	High	4.43	High	3.71	Low	
83	High	4.00	High	3.71	Middle	
95	High	3.71	High	3.71	Middle	
40	High	3.71	High	3.71	Middle	
89	High	4.00	Middle	3.57	Middle	X
85	High	3.71	Middle	3.29	High	
100	High	4.43	High	4.29	High	
50	High	5.00	High	4.43	High	

Table F5

*Movement of Students in the Pretest Low-Treatment Group on the Dimension of Enjoyment*

Student	Pretest group	Science group	Posttest group	Meets movement criteria
24	Low	Low	Low	
72	Low	High	Middle	X
16	Low	Middle	Middle	X

Table F6

*Movement of Students in the Pretest Low-Control Group on Dimension of Enjoyment*

Student	Pretest group	Science group	Posttest group	Meets movement criteria
92	Low	Low	Low	
78	Low	Low	Low	
88	Low	Low	Low	
53	Low	High	Low	
82	Low	Middle	Low	

Table F7

*Movement of Students in the Pretest High-Treatment Group on Dimension of Enjoyment*

Student	Pretest group	Science group	Posttest group	Meets movement criteria
2	High	Low	Low	X
59	High	Middle	Low	X
8	High	Middle	Middle	X
23	High	Middle	Middle	X
27	High	High	Middle	
55	High	High	Middle	
75	High	High	Middle	
11	High	High	High	
20	High	High	High	
61	High	High	High	
77	High	High	High	
19	High	High	High	
26	High	High	High	
60	High	High	High	
64	High	High	High	
70	High	High	High	
1	High	High	High	
7	High	High	High	
65	High	Middle	High	

Table F8

*Movement of Students in the Pretest High-Control Group on the Dimension of Enjoyment*

Student	Pretest group	Science group	Posttest group	Meets movement criteria
91	High	Middle	Low	X
93	High	Middle	Middle	X
30	High	Middle	Middle	X
45	High	High	Middle	
99	High	Middle	Middle	X
47	High	High	High	
38	High	High	High	
44	High	High	High	
46	High	High	High	
50	High	High	High	
100	High	High	High	

Table F9

*Movement of Students in the Pretest Low-Treatment Group on the Dimension of Interest*

Student	Pretest group	Science group	Posttest group	Meets movement criteria
66	Low	Middle	Low	
24	Low	Low	Low	
56	Low	Middle	Low	
16	Low	Middle	Middle	X
22	Low	Middle	Middle	X
72	Low	High	Middle	X

Table F-10

*Movement of Students in the Pretest Low-Control Group on the Dimension of Interest*

Student	Pretest group	Science group	Posttest group	Meets movement criteria
92	Low	Low	Low	
78	Low	Low	Low	
39	Low	Low	Low	
53	Low	Middle	Low	
80	Low	Low	Low	
98	Low	Low	Middle	
86	Low	Middle	Middle	X
44	Low	Middle	High	X

Table F-11

*Movement of Students in the Pretest High-Treatment Group on the Dimension of Interest*

Student	Pretest group	Pretest score	Science group	Science test score	Posttest group	Meets movement criteria
76	High	4.25	Middle	3.38	Low	X
55	High	4.25	High	4.88	Low	
71	High	4.13	High	4.13	Low	
8	High	4.50	Middle	3.63	Middle	X
59	High	4.63	High	4.43	Middle	
2	High	4.88	Low	1.75	Middle	X
60	High	4.38	High	4.63	Middle	
23	High	5.00	Middle	3.50	Middle	X
26	High	5.00	High	5.00	Middle	
17	High	4.13	High	4.25	High	
75	High	4.38	High	4.50	High	
77	High	4.50	High	4.50	High	
9	High	4.63	High	4.50	High	
12	High	4.13	High	4.63	High	
61	High	4.75	High	5.00	High	
65	High	4.50	Middle	3.71	High	
70	High	4.38	High	4.63	High	
7	High	4.63	High	4.13	High	
19	High	4.50	High	5.00	High	
1	High	5.00	High	5.00	High	
64	High	4.75	High	4.75	High	

Table F-12

*Movement of Students in the Pretest High-Control Group on the Dimension of Interest*

Student	Pretest group	Pretest score	Science group	Science test score	Posttest group	Meets movement criteria
95	High	4.25	Middle	3.13	Low	X
35	High	4.38	Low	3.00	Low	X
41	High	4.13	Middle	3.25	Low	X
42	High	4.13	Low	3.43	Low	X
91	High	4.38	High	4.13	Low	X
43	High	4.13	Low	3.5	Low	X
99	High	4.38	Low	3.75	Low	X
83	High	4.38	Low	4.00	Low	X
45	High	4.57	High	4.38	Low	
30	High	4.50	High	4.25	Low	
85	High	4.63	Low	4.00	High	
31	High	4.13	High	4.13	High	
49	High	4.13	High	4.88	High	
50	High	5.00	High	5.00	High	
100	High	5.00	High	5.00	High	

## CURRICULUM VITAE

### RAYMOND E. BOYLES

#### (A) PROFESSIONAL PREPARATION

Utah State University, Utah 84321  
 Degree: PhD Curriculum and Instruction, 2014  
 Major: Technology and Engineering Education

California University of PA 15012  
 Degree: Master of Science, 2009  
 Major: Technology Education

California University of PA 15012  
 Degree: Bachelor of Science, 2008  
 Major: Information Technology

Pittsburgh Institute of Aeronautics 15236  
 Degree: Associate in Specialized Technology, 1992  
 Major: Avionics

#### (B) PUBLICATIONS

##### Most Relevant Papers

Riveral, P., Boyles, R.(2013), Training in Troubleshooting Problem-Solving:  
 Preparing Undergraduate Engineering Students for Industry

Riveral, P., Boyles, R., Lawanto, O. (2013), Bridging Engineering and Technology  
 Education Fields: Providing Synthesis and Knowledge through Historical  
 Perspectives of Engineering and Technology Education Construct. *American  
 Society for Engineering Education*

Rivera, P, Boyles, R., & Lawanto, O. (2012), Offsetting Gender Bias in  
 Engineering: Gender Equity Internet Controlled Fish Farm Curriculum Activity.  
*American Society for Engineering Education*

Santoso, H., Boyles, R., Lawanto, O. & Goodridge, W. (2011). A Preliminary Study  
 of Conducting Semi-Structured Interview as Metacognitive Assessment in  
 Engineering Design: Issues and Challenges. *American Society for Engineering  
 Education*

### **Presentations—Five Most Relevant**

TeleRobotics: The Internet, a Physical Sensor  
73<sup>rd</sup> Annual Conference Program, ITEEA 2011  
Dr. Kallis, J., Boyles, R.

Implementation of Microgravity Experiments in the Classroom  
73<sup>rd</sup> Annual Conference Program, ITEEA 2011

Teaching STEM Concepts with Agile Robotics  
Dr. Kallis, J., Boyles, R.  
73<sup>rd</sup> Annual Conference Program, ITEEA 2009

Tremaux's Algorithm with Recursion  
73<sup>rd</sup> Annual Conference Program, ITEEA 2009

“Normalcy”  
2008 Intercollegiate Art Show  
Best of Show, California University of PA, April 3rd, 2008.

“Teaching by strong interest through analogous Java Software”  
56th ANNUAL TEAP CONFERENCE  
Harrisburg, PA, November 6th and 7th, 2008

“G.S.Ohm: Electrical Innovation in Industry.” Poster presentation at National Collegiate Honors Council Conference, Philadelphia, PA, November 17, 2006.

“Societas crescit: Invention and Innovation through Team Teaching.” Panel presentation at National Collegiate Honors Council Conference, Philadelphia, PA, November 16, 2006.

### **(C) COLLABORATORS & OTHER AFFILIATIONS**

#### **Major Collaborators**

Prof John R. Kallis (California University of Pa.)

#### **Graduate Advisor**

Prof Gary Stewardson (Utah State University)



**Military:**

United States Army, Fort Carson, Co

- Unit Administrative Specialist (December 1998-April 1999)
  - Duties: Created and maintained databases for 231 soldiers;
  - Responsible for processing all information on incoming and outgoing personnel and databases implementation saved 18% manpower
- Nuclear Chemical Biological Specialist (January 1998-December 1998)
  - Duties: Maintained, overhauled and calibrated all chemical equipment; trained soldiers in how to React in certain NBC situations.
- Fire Control Repairer:
  - Duties: Served as a shop foreman; supervised eight personnel which were responsible for repairing electronic fire control equipment; repaired all electronic equipment on the M1A1 and Bradley tanks, and maintained records of cost and requisitioned funding from battalion.
  - Saved 65% in cost by performing office computer Repairs.
  - Military Achievements:
    - Two Army Achievement Medals, Army |Good Conduct Medal, National Defense Service Medal, Army Lapel Button, Army Service Ribbon, Expert Marksmanship Qualification Badge with Grenade Bar, Marksman Marksmanship Qualification Badge with Rifle Bar

**Work Experience:**

- Utah State University, January 2010 to Present
  - Instructor for TEE 2300 Electronic Fundamentals
  - Study and application of DC and AC concepts, semiconductors, digital electronics, and microcomputers
- Utah State University, January 2013 to Present
  - Instructor for ETE 1020 Energy, Power, Transportation Systems Control Technology:
    - Exploration of the concepts and processes relating to the control and

automation (both hard and programmable) of technical systems in the areas of energy and power, transportation, and agricultural and related biotechnologies.

- California University of PA, January 2008 to May 2009

Teaching Assistant

Assisted the Professor in class preparation, lesson plans, and distribution of materials. Also gained teaching experience by lecturing the class section which deals with programming robots. Managed a laboratory, which allowed students to complete experiments.

- AT&T Broadband, Pittsburgh PA, May 2000 to Dec 2002

1. Head end Technician

Responsible for all aspects of High Speed Data, Telephony and Cable Operations, Hybrid Fiber to Coax Transmissions, Programming in Visual Basic, C++, Java Scripting and M.S. Office. Experience with systems such as Cheetah, Path Tracks, and Cornerstone.

2. Access Bandwidth Technician

Responsible for implementing and maintaining telephony network systems for the Pittsburgh and Surrounding Areas. Data basing and systems programmer for repairs on nodal analysis and problem solving

- Heilig-Meyers Furniture Company, Richmond, VA

August 1994-November 1994

Network/Telephone/Alarm System Installer

Traveled throughout the United States to install computer networks, telephone and alarm systems, which also included maintenance and repair.

- Guardian Glass Corporation, Floreffe, PA

Electrical Maintenance Technician Nov 1993-Jun 1994

Installed PLC systems (Allen-Bradley); repaired and maintained laser systems, photo helix, pyrometers, and integrated control systems for network operations

- WL TJ-WRRK radio station

Installed and calibrated all transmission equipment for this radio station.